

350012

JPRS 82004

18 October 1982

Japan Report

No. 161

19980910 076

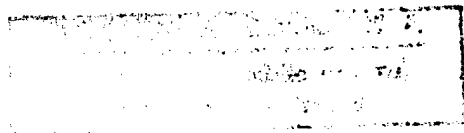

FBIS

FOREIGN BROADCAST INFORMATION SERVICE

REPRODUCED BY
NATIONAL TECHNICAL
INFORMATION SERVICE
U.S. DEPARTMENT OF COMMERCE
SPRINGFIELD, VA 22161

NOTE

JPRS publications contain information primarily from foreign newspapers, periodicals and books, but also from news agency transmissions and broadcasts. Materials from foreign-language sources are translated; those from English-language sources are transcribed or reprinted, with the original phrasing and other characteristics retained.

Headlines, editorial reports, and material enclosed in brackets [] are supplied by JPRS. Processing indicators such as [Text] or [Excerpt] in the first line of each item, or following the last line of a brief, indicate how the original information was processed. Where no processing indicator is given, the information was summarized or extracted.

Unfamiliar names rendered phonetically or transliterated are enclosed in parentheses. Words or names preceded by a question mark and enclosed in parentheses were not clear in the original but have been supplied as appropriate in context. Other unattributed parenthetical notes within the body of an item originate with the source. Times within items are as given by source.

The contents of this publication in no way represent the policies, views or attitudes of the U.S. Government.

PROCUREMENT OF PUBLICATIONS

JPRS publications may be ordered from the National Technical Information Service, Springfield, Virginia 22161. In ordering, it is recommended that the JPRS number, title, date and author, if applicable, of publication be cited.

Current JPRS publications are announced in Government Reports Announcements issued semi-monthly by the National Technical Information Service, and are listed in the Monthly Catalog of U.S. Government Publications issued by the Superintendent of Documents, U.S. Government Printing Office, Washington, D.C. 20402.

Correspondence pertaining to matters other than procurement may be addressed to Joint Publications Research Service, 1000 North Glebe Road, Arlington, Virginia 22201.

JPRS 82004

18 October 1982

Japan Report

No. 161



FOREIGN BROADCAST INFORMATION SERVICE

JAPAN REPORT

No. 161

CONTENTS

POLITICAL AND SOCIOLOGICAL

Likelihood of JSP Chairman Asukata's Ouster Analyzed (SENTAKU, Aug 82)	1
---	---

MILITARY

NHK Panel Discussion on Japan's Sealane Defense (NHK, 5 Sep 82)	6
--	---

SCIENCE AND TECHNOLOGY

MITI To Study Long-Term Space Development Program (JPE AVIATION REPORT-WEEKLY, 25 Aug 82)	16
--	----

Radiowave Absorbing Construction Materials Studied (Ken Ishino; SERAMIKKUSU, Jul 82)	18
---	----

POLITICAL AND SOCIOLOGICAL

LIKELIHOOD OF JSP CHAIRMAN ASUKATA'S OUSTER ANALYZED

Tokyo SENTAKU in Japanese Aug 82 pp 54-56

[Text] The story goes back to June of this year. Ichio Asukata, chairman of the JSP, held a private talk with Akira Iwai, former secretary general of Sohyo. Iwai is the man who denounced the present Sohyo alignment of Makieda-Tomizuka as "tilting to the right," and as a result, he is now partially forbidden from visiting the party. However, he still maintains a latent power within the Kyokai (Socialist Society), an extreme left faction of the JSP. He is looked upon as one of the members to head the Kyokai in the event something happens to Itsuro Mukaizaka. Furthermore considering that Kyokai is the main body which supports Asukata, then we can understand the significance of the talk between the two.

"Serious Remark" Revealed to Akira Iwai

Asukata made a grave statement at the meeting. He said: "We must deliberate on personnel matters, including myself, at the party conference in December of this year." "Including myself" in effect means that Asukata may resign in the midst of his term of office, or at least it suggests such a possibility. Iwai, taken by surprise, reported that to "A," a confidant and a leading Diet member, and asked for confirmation of this possibility. "A," who tends to be mischievous, called "P," a reporter of a daily newspaper, and divulged the talk between Asukata and Iwai by saying at the outset: "The fact is that I heard this from reporter "Q" of a news agency." Within a short time, Nariyuki Funabashi of the JSP Central Executive Committee went storming into the JSP Press Club. An observer said he went directly to "Q" and told him in a furious voice: "Asukata has never mentioned personally his resignation." Funabashi is the person Asukata brought from Yokohama to be designated as a member of the Central Executive Committee. He is considered within the party as a secretary to Asukata.

Regardless of what Funabashi says, Iwai heard it directly from Asukata. It is natural that Asukata's statement spread rapidly within the party. However, reactions to the statement vary, from the majority, who think that "He is very obstinate--maybe its a trial balloon," to "It is Asukata's favorite political ploy," and to a dismayed group who say, "Oh? The scheme must have leaked out."

The names of those who were dismayed will not be given here, but a steady maneuver to demote Asukata was being carried out by them. They were flustered because Asukata, who would not dream of resigning without a drastic reason, made a statement which could be interpreted to mean a resignation yet not a resignation to Iwai of Kyokai. They took it to mean that Asukata perceived the plot to demote him and undertook a strategy of self-sacrifice to squash the plot.

Be that as it may, there are many points in this plot which differ from other plans to demote Asukata. First, rather than being led by the anti-Asukata rightwingers, the main force is centered on left and neutral elements. Second, the plan came out at the time a sign of inter-party agitation appeared. Third, the post-Asukata structure within the party is now occupied mainly by the Masahi Ishibashi faction.

The plan of the "plotters" is to have Asukata resign at the party conference in December and move him to the national constituency for the House of Councilors election of next year. His election would be assured since he would be ranked first in the "binding list" under the new system. This would save his face, but if he should decide beforehand to enter the Tokyo gubernatorial election, that would be all right too and he could go ahead and become a candidate. It is doubtful, however, that Asukata would be successful in the First District of Tokyo, which is Asukata's electoral district, due to a growing anti-Asukata atmosphere with the resignation of Kiyomasa Kato, who considers that he was dragged down by Asukata, as head of Chiyoda-ku (ward). It is also said that if Asukata failed to win the party leadership, the damage would not be limited to Asukata alone but it would inflict mortal wound to the entire party.

Who will bell the "cat" is the most essential part of the plot to demote Asukata. Under the present plan, several talks will be conducted by Masahiro Yamamoto of the leftwing Kyokai, Sukio Iwatara of Kyusangatsukai (Old March Society), Takatoshi Fujita of the rightwing Shaken (Socialist Study Association) and Tsuruo Yamaguchi of Seikoken (Administrative Concept Study Association). They will study definite plans to demote Asukata and formulate an encirclement net made up of various factions of the party.

Asukata has no objection to Seikoken, but he holds certain feelings toward the other three groups. In the final analysis, a sign of reorganization has appeared among the former leftist camps known as Kyokai, Kyusangatsukai and Shaken, and they are now entwined in the move to demote Asukata.

Sign of Reorganization in Former Leftist Camps

Beginning with Kyokai, many party Diet members, members of the Secretariat and students know that one cannot survive a day by following the Kyokai's dogma that all is right with the Soviet Union. It causes estrangement from the central headquarters and contradictions appear. On the other hand, many local Kyokai members are serious-minded and tend to listen more to the central headquarters. To them, the Diet members appear corrupt.

Complaints against them are made. The younger Kyokai members are criticizing Diet member Masahiro Yamamoto as "being too soft." And 80 percent of the full-time activists doing thankless jobs such as distributing the central organ's publications are young members and affiliated members of the Kyokai. Thus, any rebellion arising from them can be frightening for the party.

An altered view "to have the Kyokai devote itself to being a true theoretical group" has become stronger among the leftist factions because, if they are ignored, a proper reorganization cannot be made. To put it plainly, they are saying that politics should be entrusted to the Kyusangatsukai, and moreover, that they should be given a "free hand."

Shaken began to squirm around as if to act in concert with the move of Kyokai-Kyusangatsukai. As is known, this is the former Sasaki faction. This faction is labeled "rightist" now. It was once a leftist group which prided itself on tradition and quality. During the midst of the PRC-Soviet confrontation, the faction took a pro-PRC and anti-Soviet stand and joined the Seikoken in opposition to the Kyokai. In looking back, practically all of the principal members of Kyokai and Kyusangatsukai were once members of Shaken. They are fraternal brothers.

The downfall of Shaken is pitiful. With the defeat of Shoichi Shimodaira in the election for party chairman and the shift of devoted pro-China members who could no longer support China's upheaval, publication of its organ SHINRO was discontinued. A resumption of this publication was being sought for various reasons. As a result, the slogan "New Age Faction" emerged. A decisive self-criticism was made at the national conference of Shaken held in September at Atami "to recognize candidly that the insufficient theoretical elucidation on the question of who is the main enemy between the United States and the Soviet Union hegemony, the change in evaluation of the Great Cultural Revolution in China, the failure of left extremism of the Pol Pot regime, and the weak analysis regarding imperialism and modern capitalism has put a brake on the Shaken movement."

Kyokai was perplexed by the series of Soviet barbaric actions such as the invasion of Afghanistan. Shaken also fluttered around in regard to the instability of China and would not say that "both Russia and America are equally wrong" when the Reagan administration came out with its arrogant military expansion line. Such pitching and rolling of the JSP leftist camp can only be regarded as comic, but going back to what I was saying, these situations are why a reorganization of the leftist camp can be anticipated.

It is strange, but Shaken has appeared to maintain that in actuality Asukata will do as a chairman even though Shimodaira is a possible candidate for the chairmanship. In a situation where there is no actual candidate, there is no intention of leading the way to oust Asukata. Rather, Shaken detests Ishibashi. If Ishibashi were to become the chairman, Seikoken would have one of its members serve as chief secretary, which would leave Shaken with no chance to participate. This is what it fears.

This anxiety hit the mark in July. It did not involve major positions such as that of chief secretary, but the position of chief of the General Affairs Department of the General Affairs Bureau, an important post in the party Secretariat, went to Shaken's former Katsumata faction; in other words, to a person affiliated with Ishibashi. Seikoken, which was supposed to be a sworn friend, feigned indifference. Moreover, one of the persons who brought the subject of a reshuffle to Ishibashi was from Seikoken. Anticipating that Ishibashi will be the next chairman, more and more members are trying not to miss the bus.

Shaken is aware of this and does not want to take an isolated road. It appears that it will be represented in the four-man meeting to oust Asukata.

What about Kyokai? It unanimously takes the position that it is not necessary to oppose Asukata. Kyokai's general line, "Ishibashi next," has not changed. This is the line Mukaizaka advocated earlier. The rest is timing, and if an opportunity can be seized, Asukata's downfall can be effected speedily.

Ishibashi is watching these situations very patiently. But sources close by are saying that he is no longer hiding his criticism of Asukata. Masahiro Yamamoto of Kyokai cautioned Ishibashi about becoming excessive in his criticism: "Please moderate your criticism against Asukata. If you criticize too harshly, the task will become difficult." It continues to be an abdication without creating a storm, but one of the members who is trying to oust Asukata said: "It does not make any difference when we come this far. We are thinking of having Ishibashi attend the factional cross-section meeting."

"Replacement" Ishibashi Eagerly Watching

Ishibashi is dissatisfied with Asukata because he is avoiding a heart-to-heart talk with him. Asukata pretended ignorance on the important personnel matters, although he agreed with Makieda of Sohyo. In addition, Ishibashi is dissatisfied with the politically tone-deaf statements and actions of Asukata. On 19 July, Asukata came out with the proud posture that "I will fight to the utmost for the Socialist proposal at the lower house level" in reference to the revision of the Public Officers Election Act (reform of House of Councilors national constituency) during the meeting of the Committee for JSP-Sohyo Cooperation. However, it is absurd if Asukata believes earnestly that the revision can be made. Regarding timeliness, approval can be very delicate. Even if a revision is approved by the Lower House, it must be sent to the Upper House, and this reduces the possibility of its passage. Ishibashi believes that a move to quash this in accordance with public opinion is another matter, but that a cheap attempt to pass it should be avoided at this time.

A favorable situation for Ishibashi now is the declining popularity of Noboru Baba, who was forcefully pushed into the chief secretary's position by Asukata. At the time, the labor side agreed to have Ishibashi fill the chief secretary post. Asukata did not once say: "I would like to

have you serve as chief secretary." It is claimed that it was fortunate for Ishibashi, as he did not have to deal with the aftermath of Asukata by being appointed chief secretary. Whether he becomes one or not, the fact that there was no acknowledgment from Asukata struck Ishibashi very hard. Asukata and Baba are lying low at this time. It is strictly a JSP "moratorium," but this situation cannot harm Ishibashi. His wish to be nominated unanimously as chairman may no longer be a dream in due time. (Incidentally, Ishibashi is opposed to election of the chairman by popular vote. He says that votes by party members, whether LDP or JSP, do not necessarily mean that the best person will be elected.)

The question is whether Asukata is willing to forgo the chairman's post readily or not. Going back to his statement of Iwai mentioned at the beginning, the demotion of Asukata during his term of office is a joke. Asukata relies on the Shinsei Kenkyukai (Shinseiken-New Life Study Group). Although it may sound too blunt to say that Asukata did it just for such an eventuality, he has placed two of his assistants in important positions: chief secretary (Noboru Baba) of Shinseiken and chairman (Yuzuru Shimazaki) of Sieshinkai (political deliberating society).

Shinseiken will hold a study meeting at Atami in August. Attention will be focused on Asukata's participation as an "adviser." Factions are found in both the LDP and the JSP, but even the LDP's president does not attend his own factional meeting. Shinseiken is known as the bodyguard of Asukata. Even if he is an "adviser," his attendance naturally will invite complaints from other factions. Conversely, however, it may mean that Asukata and his close associates are being driven into a corner.

9218
CSO: 4105/181

MILITARY

NHK PANEL DISCUSSION ON JAPAN'S SEALANE DEFENSE

OW061045 Tokyo NHK Television Network in Japanese 0000 GMT 5 Sep 82

[NHK political panel discussion entitled "'Sealane Defense' and Japan's Option" with Director General of the Defense Agency Soichiro Ito; chairman of the Nomura Research Institute of Technology and Economics Kiichi Saeki; former Defense Agency Administrative Vice Minister Ko Maruyama; Sophia University Professor Sarashi Kawada; and military commentator Akio Yamakawa speaking, and NHK commentator Kazuo Okamura acting as moderator--pretaped; date and place not indicated]

[Excerpts] [Okamura] At the 3-day working-level Japan-U.S. security talks in Hawaii last week, the two sides agreed to conduct a joint study on ways to defend sealanes. This sealane defense issue is very important in planning Japan's future security and defense. In this context, today we will present a panel discussion entitled "'Sealane Defense' and Japan's Option." Participating in this discussion are the following five guests: Director General of the Defense Agency Soichiro Ito; Kiichi Saeki, chairman of the Nomura Research Institute of Technology and Economics and director of the security department of the Council for Transport Policy; former Defense Agency Administrative Vice Minister Ko Maruyama; Sophia University Professor Sarashi Kawada; and military commentator Akio Yamakawa. Acting as moderator is NHK commentator Kazuo Okamura.

[Okamura] Director General Ito has just outlined what was discussed at the Hawaii talks. Now, I would like to hear your views on the results of the working-level security talks last week, Mr Saeki.

[Saeki] I would like to give the recent Japan-U.S. talks credit for frank and smooth proceedings, compared with the previous meeting. I feel that the talks were also successful in that the two sides had chances to discuss to some extent their respective scopes of responsibilities in sealane defense. The meeting was equally satisfactory in that the two sides agreed to conduct a joint study on how to perceive the Soviet threat, what scenarios are conceivable concerning sealane defense, how much defense capability is required, and other future issues. The question is how Japan will handle these issues in its own interest. This is what Japan has to tackle in the future. Japan should handle these issues not because the United States forces it to do so. It should handle them on the basis of its own judgment as to their needs and feasibility. Japan should firmly realize the importance of this attitude.

[Okamura] Mr Maruyama, what is your view of the Hawaii talks last week, particularly on the discussion of the sealane issue?

[Maruyama] Concerning this year's talks, they were to proceed in a frank atmosphere as Mr Saeki pointed out. I am very glad that the security talks regained their early frankness in the recent session. I am also glad that the two sides at least reached an agreement to jointly study ways to defend sealanes in the future. Since the two countries are allies, I hope that they will have frank and open-minded talks in the future rather than being mutually cautious.

[Okamura] Mr Kawada, what do you think about the Hawaii talks last week and the joint study of the sealane defense?

[Kawada] I think that I was invited to this discussion because of my constant criticism of the buildup of Japan's defense capabilities as a private citizen of Japan. When I read press reports, I cannot but feel deep misgivings as a private citizen. In the past, the Defense Agency and the government authorities appeared to seek "defensive defense" or the maintenance of basic defense capabilities. Of course, I was aware of some fake aspects in this avowed government line. Nevertheless, I acknowledged their efforts along this line to some degree. However, the recent meeting caused me to have apprehensions as to a possible departure from that line toward exceedingly heavy defense capabilities. I fear that Japan may be dragged into a new U.S. containment strategy against the Soviet Union, a U.S. strategy seeking to step up its local linkage to contain the Soviet Union. I fear that this will be a very serious development as a nation seeking peace.

[Okamura] How about you, Mr Yamakawa?

[Yamakawa] Defense Agency Director General Ito said that the question of sealane defense is to be studied now and, according to press reports, there exists the view that sealane defense is not the Japanese Government's pledge. But I doubt this very much. I think that, while having no strategy of its own to speak of, Japan is allured by such goblins as sealanes and defense and is about to be drawn into the military and global strategies of the United States. This is the beginning of it, I would say.

When he visited Washington in May, last year, Prime Minister Suzuki made a statement concerning sealane defense which can be regarded as a public pledge, and also said that Japan is a member of the West and an ally of the United States. This point remains ambiguous but, at the recent Hawaii meeting, the two sides reportedly agreed in broad terms on the international situation. If this is true, the question brought up this time may undergo meanderings, but I get the feeling that it will eventually develop in the direction sought by the United States.

In the first place, sealane defense is not a question which has been brought up only recently. When Mr Yamanaka was serving as Defense Agency director general, it was brought up informally as feeder route defense. I heard about

it. Later Defense Agency officials centering around the Maritime Self-Defense Force [SDF] undertook various projects involving a convoy method and a barrier method. I am not going to elaborate on this. More recently, in late May, even a cabinet meeting on security was held in connection with sealane defense. So, it is not that the government is starting its study of the question now.

The content of the 1981 mid-term work estimate centers around sealane defense including the addition of 50 P-3C antisubmarine patrol planes. The secret consultations underway to discuss a so-called emergency in the Far East give me the impression that Japan is arriving at a very grave turning point. As a matter of fact, I am participating in this panel discussion to find out the truth directly from the Defense Agency director general from the position of the people who are very much worried like Professor Kawada.

[Okamura] Director General Ito and four other guests have just expressed their views on the security meeting. Mr Kawada and Mr Yamakawa rather expressed their fears that Japan may depart from its position of "exclusively defensive defense" and plans to maintain basically required defense strength. Director General Ito, could you briefly mention the background of the recent sudden emphasis on the issue of sealane defense?

[Ito] As has been mentioned by other guests here, it is our desire to thoroughly safeguard our nation, a peaceful nation. If there is a nation which has an aggressive design against our peaceful nation, we naturally should maintain our defense capabilities to foil or check the design beforehand. To this end, we should steadily seek to improve the shape of our national defense from all angles and standpoints. I believe that national defense is a goal toward which we must make endless efforts. We should foil any aggressive designs beforehand in order to protect our peaceful nation. To this end, we have to think about our national defense from all angles. Thus, we wanted to study more closely sealane defense in the recent talks with the United States although the issue had already been contained in our defense buildup plans. Our own, voluntary efforts and the Japan-U.S. security treaty are two pillars of our national defense. Therefore, we wanted to hear fully the views and plans of our partner and to protect Japan, a peaceful nation, based on a common perception of the situation between Japan and the United States. This is how we began closer studies of the issue. It is not a new issue which has suddenly begun to draw our attention.

[Okamura] Mr Maruyama, as you have mentioned, in the past you worked to resume the working-level security talks while serving as chief of the Defense Bureau and administrative vice minister of the Defense Agency. Some people say that sealane defense is not necessary and that it is impossible. What do you think?

[Maruyama] In the beginning of this discussion, you made an explanatory account of sealanes, Mr Okamura. As you said, people have various, different views as to the concept of "sealane." I am not saying which view is correct or which one is wrong. In terms of conception, a considerable number of people

think that a sealane is a specific linear belt on the sea like railways. They think that sealane defense means protection of such a belt. This is not true. As a matter of fact, the sea is an unbounded entity. Sealane should rather be interpreted as a method of sea communications. Communications through this method are called sealane communications in the United States. Similarly, there is a concept called airline communications. There are different approaches in sealane defense, based on the extent of the threat posed by a certain country or countries to sealane communications. When sealane communications are 100 percent or partially guaranteed, we should have different defense approaches. As was mentioned in the beginning of this discussion, Japan's dependence on foreign countries in terms of resources and exports is very high. Accordingly, Japan has a very high dependence on traffic with foreign countries. As is well known, Japan has to import even daily necessities such as buckwheat and coffee. Thus, it is a vital issue for Japan to secure means of trafficking with foreign countries. We have to make every possible technical study to secure them. I do not agree with the position of those who give up efforts to this end from the very beginning.

As I have said, some people have different concepts of a sealane and argue that it is impossible to defend sealanes. However, I believe that they will all agree that it is necessary for Japan to somehow protect this system of traffic with foreign countries. The question is how to practically and actually maintain the system. I will express my views on this issue later.

[Okamura] It is true that sealane communications are a vital life-and-death issue. The current arguments over the defense of the 1,000-nautical-mile sealanes primarily concern the question of tasks to be assumed by both the maritime and air self-defense forces. Mr Kawada, is sealane defense really necessary? Is it really an issue worth our study? Some military experts express the opinion that, in view of the presence of Soviet Far East forces and its Pacific fleet, it is impossible to defend sealanes. May I hear your views on these questions and this opinion?

[Kawada] From a broad viewpoint, the sea routes from the Middle East to Japan are very vital to Japan. However, it is not a good idea to defend them only by military means. It is very important to maintain friendly relations with nations located near the sea routes through economic cooperation and various other means. Regarding the opinion expressed by some experts, I would like to say that the opinion concerns what we call the Soviet threat. It may be certainly true that the Soviet Union actually has strong submarine and air forces. However, it is really hard for me to understand what direct bearing the presence of those forces in Vladivostok has on those sealanes. U.S. military sources say that it is unlikely that the Soviet Union would directly invade Hokkaido. This means that the above-mentioned presence of Soviet forces does not actually pose a threat to Japan at this moment. The United States is now eagerly talking about the Soviet threat. I think that this is a phenomenon stemming from a great shift in U.S. world policies under the Reagan administration. We will be making a great mistake if we think that current U.S. policies are unchangeable and invariably authoritative and correct. A report--the Glenn report if I remember correctly--which was presented to the U.S. Congress 3 years ago, recommended that Japan remain a lightly-armed

nation. This indicates that the U.S. has not always asked for a Japanese military buildup. The U.S. position on this issue has undergone broad changes. Likewise, U.S. world policy could change in the future. I believe that it will change. The world is now stepping into a multipolar era and, under such circumstances, the containment policy against the Soviet Union is impossible, however hard we might try. Therefore, it would not be wise for Japan to be dragged into such U.S. policies at present. I believe that Japan should conceive its own independent national security.

[Okamura] Before further proceeding with this discussion, I would like to ask Director General Ito two questions. Now, let us study the sealane chart here. In short, at the recent Hawaii meeting, the Japanese side indicated that it would protect the 1,000 nautical mile sealanes--the Southeast sealane and the Southwest sealane--with a supposed width of 200 or 300 km. However, the U.S. side reportedly expressed a different view. It asked Japan to defend a broad fan-shape sea zone between the Southeast and Southwest sealanes. The other question concerns my understanding that the Defense Agency plans to protect about 200 million tons of imports--one-third of less than 600 million tons of the estimated annual import shipments--in the event of an emergency. Is this true?

[Ito] It is a purely military question whether the defense should be limited only to the sealane belts or the entire fanshape sea zone should be protected. We would like to have competent experts discuss this question in the future. I suppose that there would be varied options over this issue. I cannot answer the question in a generalized manner at present. I would like to entrust the question to the experts concerned. As I have already mentioned, as a nation which is surrounded by sea, it is natural for Japan to defend its waters. To this end, it is true that we are making some numerical calculations as you have just said. These calculations were begun several years ago by a branch under the chief of staff of the Maritime Self-Defense Force. Based on the then economic data, the branch figured that Japan imports, on an average, 600 million tons annually and that she should have naval defense capabilities strong enough to ensure import of at least 1/3 of that amount in times of emergency. It is true that the Defense Agency is making those calculations, but they still represent an estimate and have not yet developed into a definite and entire program for the Defense Agency. They will be included in future studies and discussions.

[Okamura] Director General Ito, as has been pointed out by Mr Yamakawa, in a fundamental sense does Japan's sealane defense not represent a shift of responsibility from the United States in compliance with U.S. world and Far East strategies? It is really disturbing to think that we have to prepare against forces in Vladivostok. How should the Japanese Government respond to a possible U.S. demand that, in the event of an emergency, Japan block its three straits? What do you think?

[Ito] I am frequently asked the same question. As director general of the Defense Agency or as the man in charge of national defense, I am in the position to have the most frequent contacts with U.S. officials dealing with defense matters. It is certain that we receive various requests from the U.S.

side. However, I always tell them that Japan has many restrictive conditions to consider, including public opinion and the stern historical fact that we are the only country which actually suffered from the atomic bomb. Needless to say, the United States understands Japan's position. In this sense, it is not totally true that Japan is being dragged into U.S. strategies as has often been alleged in various publications. We have our say whenever it is necessary. As has been praised by Mr Saeki and others, the Japanese delegation laboriously explained the position of Japan to the U.S. side at the Hawaii meeting, where the U.S. side made very stern requests of Japan. I hope that there will be no misunderstanding in this regard. In this context, it is solely to defend Japan that we discussed the issues of the three straits and sealanes.

It is an exercise of our right to self-defense that we discuss and formulate better operational programs and ask the United States for support where we have in sufficient capabilities. We have repeatedly stated this. At this discussion, someone referred to what happened to the seamen's union in the past. We would like to defend our sealanes in the event of emergency, without forcing the past painful sacrifices on the seamen's union. We will make efforts not to repeat such past sufferings. Our purpose is to have a kind of deterrent power which can foil, in advance, the intention of a country to strike at our sealanes, should there be such a country. Accordingly, the question of blockading the three straits and that of Vladivostok may be considered only if such a blockade is necessary for Japan's self-defense. We will not discuss the question simply because the United States presses for it. Especially, the question of blockading the three straits is, saliently, a big international question; I believe this question is a serious political one, which must be handled with extreme prudence.

[Okamura] Mr Maruyama, I want to change the subject. During last year's Japan-U.S. consultations in Hawaii, the United States reportedly made a request, which considerably exceeded the defense level envisaged in the 1983-1987 defense buildup plan and the defense program outline. In your opinion, can sealanes out to 1,000 nautical miles be defended with the level of defense envisaged by the 1983-1987 defense buildup plan and the defense program outline?

[Maruyama] Since the defense program outline is mainly based on a peacetime situation, if we look ahead, say 10 years ahead, or beyond 1987, the last year of the 1983-1987 defense buildup plan, I think, in my personal opinion, that the level of defense envisaged by the outline and the buildup plan are insufficient. We have to come up with an appropriate plan.

Our air defense capability over sea is totally insufficient. As is often pointed out, more backfires have been deployed, and the recent Falklands dispute between Britain and Argentina underscored the great threat posed to ships by aircraft. This requires us to recalculate the figures.

[Okamura] Director General Ito, Mr Maruyama has just pointed out that the 1983-87 defense buildup plan and the present defense program outline are insufficient for the defense of sealanes, particularly seen from an air defense point of view. What is your own opinion? Furthermore, there is the "1 percent of GNP" ceiling on defense outlays which was adopted at a cabinet meeting in 1976. What do you think of this ceiling?

[Ito] Before answering your question, I would like to clarify one thing: earlier, I mentioned Valdivostock, accidentally repeating the name after Mr Yamakawa had mentioned it. As far as the Defense Agency is concerned, it has not the slightest intention of blockading Vladivostok. I want to stress that our concept of purely defense capabilities does not stretch that far.

What we are aiming at is a basic defense capability, and this, I believe, is being gradually understood by the public, thanks to explanations by Mr Maruyama and by other means. We want to achieve the level of defense which is absolutely necessary for Japan in peacetime as soon as possible. We seek to attain that level at the end of the 1983-87 defense buildup plan, under the defense program outline. It will be very difficult to completely attain this goal for fiscal and various other reasons. So we are trying to attain most of it. The nature of defense is such that it is impossible to be 100 percent complete in every aspect. What we need is steady, unceasing efforts. The 1983-1987 defense buildup plan is one of the goals for these efforts.

As for the 1 percent ceiling, the cabinet decision on this ceiling is very important, as repeatedly pointed out by the prime minister and myself. So we have to abide by it. On the other hand, it is our duty, as defense officials, to achieve a defense capability which is reliable in the eyes of the public. The 1983-1987 defense buildup plan is the fruit of our efforts to integrate these two requirements. It is our judgment that there is no need to change during the plan period the cabinet decision on holding defense outlays below 1 percent of the GNP. When it comes to a question of how much the plan can contribute to sealane defense, we cannot say that it will ensure 100 percent sealane defense, just as there is no way of achieving perfection in defense, but we believe that we will be able to defend our sealanes in considerable strength.

[Okamura] Mr Maruyama, we understand that earlier 6 million tons of cargo is carried into Japan, mostly by foreign ships or chartered foreign ships. If the Japanese self-defense forces use arms to cope with attacks on these foreign ships, or the Japanese SDF react to an attack on the 7th Fleet, does this represent an exercise of the right of collective defense?

[Maruyama] I understand the academic arguments presented by scholars. Some of them argue that a warship represents an extension of territory, and if Japan defends a warship of another country, it will mark the first step toward exercising the right of collective self-defense. Even some government officials hold this view. When a country is attacked by a third country and if its ally comes to its aid, this represents an exercise of the right of collective self-defense as defined by the UN Charter. In the case of Japan, if it is attacked by a foreign country, the United States is duty bound to defend Japan. On the other hand, if the United States is attacked by a third country, Japan is under no obligation to defend the United States. The Japan-U.S. security treaty is based on this principle. Therefore, if Japan joins in an action connected with defending the United States, it may be said that Japan opted to exercise the right to collective self-defense.

However, an attack which takes place within 1,000 miles of Japan, constitutes aggression against Japan. So defending Japanese territory represents an exercise of Japan's inherent right to individual self-defense. Since the United States cooperates in this defense, I believe that the allegation about a violation of the constitution is groundless if the matter is considered broadly and reasonably.

[Okamura] Defense Agency Director General Ito, what do you think of Mr Maruyama's interpretation? Article 5 of the Japan-U.S. security treaty deals with an armed attack on territories under the administration of Japan. What is your interpretation of the Japanese SDF's reaction to an attack on the 7th Fleet, when viewed from the standpoint of the right to collective self-defense?

[Ito] We take the stance that an action taken for Japan's self-defense, when Japan is attacked does not violate the constitution or fall within an exercise of the right to collective self-defense.

[Okamura] Director General Ito, when do you think the current joint study on sealane defense will reach a conclusion and how the conclusion will be reflect in Japan's defense policy?

[Ito] Our working-level officials have just returned, and preparations will soon be undertaken. So I cannot say now when the conclusion will be reached. As for the question of what will happen as a result of the study, some aspects may be taken into our defense policy and others may not. The question will be considered when the time comes. The purpose of the study is not to reflect its results in our defense policy. We plan to approach the study with the stance I mentioned earlier.

[Okamura] Thank you very much.

CSO: 4105/205

SCIENCE AND TECHNOLOGY

MITI TO STUDY LONG-TERM SPACE DEVELOPMENT PROGRAM

Tokyo JPE AVIATION REPORT-WEEKLY in English No 585, 25 Aug 82 pp 8-9

[Text] The Ministry of International Trade and Industry (MITI) will set up a task force in its Machinery and Information Industries Bureau possibly in early October to study a long-term vision for Japan's outer space industry, especially software technology for outer space utilization.

The task force, tentatively named the Space Industry Vision Committee, is expected to map out the vision by March 1983. Under the vision, MITI will proceed with development of software technology as well as rockets, satellites and other hardware in order to solidify the Japanese outer space industry.

Japan has launched more than 20 satellites since 1970, while the space industry's annual sales have reached ¥100,000 million, according to a report worked out by an advisory body to the bureau's director-general in April 1981. But the Japanese industry's technological foundation is said to be less competent than in Europe and the United States. Furthermore, its market is smaller and more barriers exist against its introduction of foreign technology.

Although Japan's advanced electronics technology has sharply improved its satellite know-how, it is far behind other industrialized nations in developing software or ways to utilize outer space.

The task force, consisting of space development experts, will study new ways to use outer space, projected 10 to 20 years ahead, and also how to produce industrial needs based on that projection. These factors will be incorporated into the long-term vision.

Specific ways to use outer space would include Japan's cooperation with foreign nations in launching maritime observation satellites. Such cooperation could lead to

international development of maritime resources. Japan now plans to launch such satellites on its own.

Other ways would include how to effectively use data collected by meteorological satellites.

NASDA TO LAUNCH TEST SATELLITE AUG. 26

The National Space Development Agency (NASDA) will launch an engineering test satellite, named the ETS-III, from its Tanegashima Space Center on Aug. 26 for the purpose of establishing basic technology for future large satellites.

Among the satellites which Japan launches on its own, the ETS-III is the first one to adopt the three axial attitude control system.

The launching booster will be the ninth and last N-1 rocket. NASDA started using the N-1 rocket five years ago.

CSO: 4120/421

RADIOWAVE ABSORBING CONSTRUCTION MATERIALS STUDIED

Tokyo SERAMIKKUSU in Japanese Jul 82 pp 530-536

[Article by Ken Ishino, TDK Electronics Co, Ltd]

[Text] I. Introduction

As a result of the concentration of the population in urban centers accompanying the high degree of economic growth, there has been a trend toward high-rise construction in order to utilize land area more effectively, and this trend has caused the emergence of TV ghost interference as a matter of utmost concern to city dwellers.

As shown in Figure 1, TV reception interference due to construction can be classified into two groups: a reflection phenomenon resulting from the reflection of radio waves from the walls of buildings in the so-called "ghost interference" behavior, and a phenomenon in which radio waves are obstructed to cause "building shadow interference." It is said that the average number of households which experience building shadow interference is 20-30 per building, while the number of households experiencing ghost interference is estimated to be several hundred.⁽³⁾ At the same time, building shadow interference is considered to be created by reflected radio waves dormant in the wall rather than the obstruction and weakening of radio waves. This is why the structure itself is the main problem which has to be considered in any countermeasures for TV reception interference.

[see Figure 1 next page]

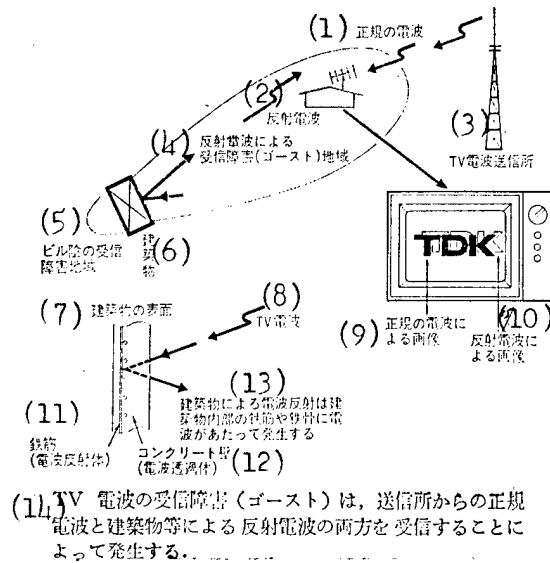

Figure 1. Mechanism of ghost generation.

- Key:
- | | |
|---|--|
| 1. Normal radio wave | 2. Reflected radio wave |
| 3. RV transmission station | 4. Region of reception interference (ghost) due to reflected waves |
| 5. Reception area in shadow of building | |
| 6. Construction | 7. Surface of construction |
| 8. TV wave | 9. Normal picture image |
| 10. Image with reflected wave | |
| 11. Steel reinforcing (radio wave reflector) | |
| 12. Concrete wall (radio wave transmitter) | |
| 13. Radio wave reflection from a structure is created when radio waves are incident on reinforcing steel or iron aggregate within the structure. | |
| 14. Interference reception of radio waves (ghost) is generated when normal waves broadcast by the station and reflected waves from structures and other sources are received. | |

TV electromagnetic waves possess diffraction and reflection properties just as light. As a result, when TV waves traversing free space strike against a medium unlike free space such as a metal plate, reflective phenomena are created just as with light. The magnitude of this reflection is determined by the degree to which the electromagnetic properties of this medium differ from those of free space.

Some electromagnetic wave reflection properties of representative building materials are listed in Table 1.

Table 1. TV wave reflection rate of building material.

(f = 100 MHz)

(1) 金属板	100%
(2) コンクリート (鉄筋入り)	90
(3) コンクリート (無筋)	10
(4) ガラス	0.3
F R P	6
(5) 磁器タイル	2
(6) モルタル	16
(7) フェライト電波吸収体	0.5

- Key:
1. Metal plate
 2. Concrete (with steel reinforcement)
 3. Concrete (with no reinforcement)
 4. Glass
 5. Ceramic tile
 6. Mortar
 7. Ferrite magnetic absorber

Radio wave absorbers usually are effective countermeasures for attenuating reflected radio waves. For example, antenna experiments conducted within a room and measurements of incident interference removal property demonstrated that the placement of radio wave absorbers on the walls of a room prevented reflection from the walls and was very effective in creating a chamber opaque to radio waves close to that of an apparently limitless space. On the other hand, no material has been developed which has good weather resistance and of sufficient thinness for outdoor use, and the development of new material which selectively absorbs radio waves is awaited. The countermeasures to date have been limited to CATV type localized efforts.

Professor Suetake and colleagues at the Tokyo Institute of Technology focused on magnetic properties in the high frequency region of the oxide ceramic "ferrite," which is one of the ceramic materials, and conducted a series of studies on their use as magnetic radio wave absorbers, as a result of which they demonstrated that ferrite can be placed in thin layers on the walls of a small radio wave opaque room and display excellent radio wave absorbing property (6-8). Based on these results together with the weather resistance and thin layer forming property of ferrite, they directed their attention to the reassessment of ferrite as a building use radio wave absorber, and practical experiments were conducted on various aspects mainly at NHK buildings (9-11).

As a result of these researches, the first effort in the world to put into practice on a practical scale countermeasures to prevent ghost interference was made on a sewage treatment plant (five stories aboveground, height 25 meters) constructed in the Inada District of East Osaka by the Osaka Urban Prefecture 2 years ago. As shown in Figure 2, the ghost interference area involved roughly 300 households between 250 meters and 500 meters (about 250 meters east of the Senya River) east of the building. NHK took cost

performance into account and computed the predicted interference improvement effect with the aid of a large computer, as a result of which it decided that rather than install this material on the entire wall, only about 40,000 pieces of tile covering about 650 square meters of the east wall at the fourth and fifth floors and projecting towers would suffice.

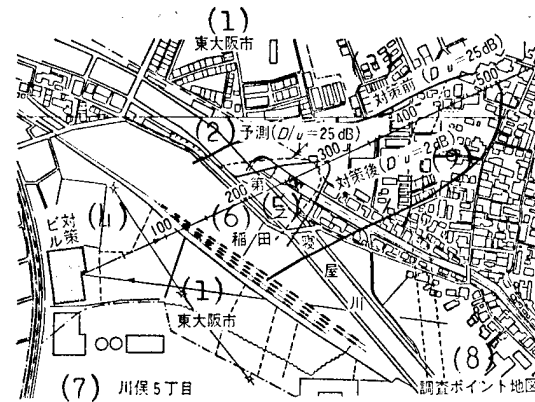

Figure 2. Ghost interference area before and after installation of radio wave absorber.

- Key:
1. East Osaka City
 2. Predicted ($D/u = 25$ dB)
 3. Before installation ($D_u = 25$ dB)
 4. Building countermeasure
 5. No 2 Senya River
 6. Inada
 7. Kawayasu 5 Chome
 8. Map of observation points
 9. After countermeasure ($D_u = 2$ dB)

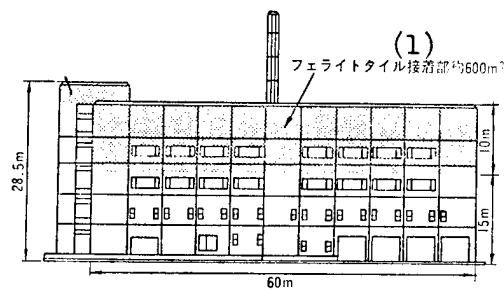

Figure 3. Sections where ferrite tile was installed.

- Key: 1. Ferrite tile installed area about 600 square meters

The method of installation was to place the tile directly on the concrete wall with a strong adhesive and then to coat this surface with an epoxy paint finishing coat. The improvement effect was as predicted (see figure 2); the

interference range was reduced from 500 meters to 300 meters, the TV reception of 300 households was essentially resolved, and the ghost countermeasure was successfully executed.

Whereas ghosts were so strong before the tile installation that "watching TV became too difficult," the ghost problem could essentially be ignored once the tile was installed. As a result, a maintenance fee became unnecessary, compared to CATV which resorts to the use of cables, and there was no need to confer with different individuals; attention was renewed on the use of ferrite as a radio wave absorber for building use.

This paper will introduce the subject of radio wave absorbers for building use for resolving the radio wave interference problem considering mainly ferrite.

II. What is a Radio Wave Absorber?

Radio wave absorber refers to a material which absorbs radio waves and attenuates the waves almost completely or essentially does not reflect these waves, and a material which causes loss in electromagnetic energy (radio waves) no matter which mechanism takes place.

Carbon is known to be a material which causes resistance loss and has long been used in this role; carbon powder supported by some suitable material (such as polyurethane foam) has found practical use as an electromagnetic wave absorber. This type of electromagnetic wave absorber is light in weight and also displays electromagnetic wave absorbing property over a wide range in wavelengths. On the other hand, a thickness of about 1.5 meters is necessary in the high frequency of VHF TV and its weather resistant property is rather poor, so that its application has been limited to indoor use.

A new electromagnetic wave absorber was developed as a material which causes loss in electromagnetic energy in the form of ferrite. Its thickness for use in the VHF band ranges between 4 mm and 10 mm, and a thickness of roughly 1/200 that of the carbon absorber will suffice in the design.

At the same time, the physical properties of ferrite, shown in Table 2, are similar to those of tile for external use. Some of the reasons ferrite tile drew attention as ghost countermeasure material in the construction trade are the thinness and superior weatherability of the same order as regular tile.

(see Table 2 next page)

Table 2. Various properties of ferrite.

(1)項目	(2)特性値
(3)直流抵抗率	$10^6 \Omega \cdot \text{cm}$ 以上 (11)
(4)密度	4.8 g/cm^3
(5)抗折強度	$5.5 \times 10^3 \text{ kg/cm}^2$
(6)圧縮強度	$2.4 \times 10^3 \text{ kg/cm}^2$
(7)熱膨張係数	$10 \times 10^{-6}/^\circ\text{C}$
(8)熱伝導度	$1.5 \times 10^{-2} \text{ cal/s} \cdot \text{cm} \cdot \text{deg}$
(9)比熱	$0.2 \text{ cal/g} \cdot \text{deg}$
(10)吸水率	0.2%

- Key:
1. Item
 2. Characteristic value
 3. DC resistivity
 4. Density
 5. Transverse rupture strength
 6. Compressive strength
 7. Thermal expansion coefficient
 8. Thermal conductivity
 9. Specific heat
 10. Moisture absorption rate
 11. More than $10^6 \Omega \cdot \text{cm}$

III. Design Methods for Ferrite Radio Wave Absorbers (11)

The basic structure of a ferrite radio wave absorber is illustrated in Figure 4. A number of 100 x 100 mm ferrite tiles are pasted close together on a metal plate. The reason for this construction is that this design enables a total synthetic reflection close to 0 in the multiple reflection model. This is an extremely simple type; the mechanism for attenuating radio waves is illustrated in model manner in Figure 5 (a) and (b).

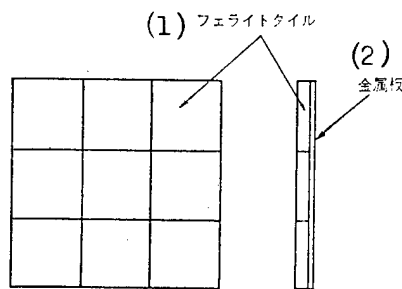

Figure 4. Construction of ferrite radio wave absorbing wall.

- Key:
1. Ferrite tile
 2. Metal plate

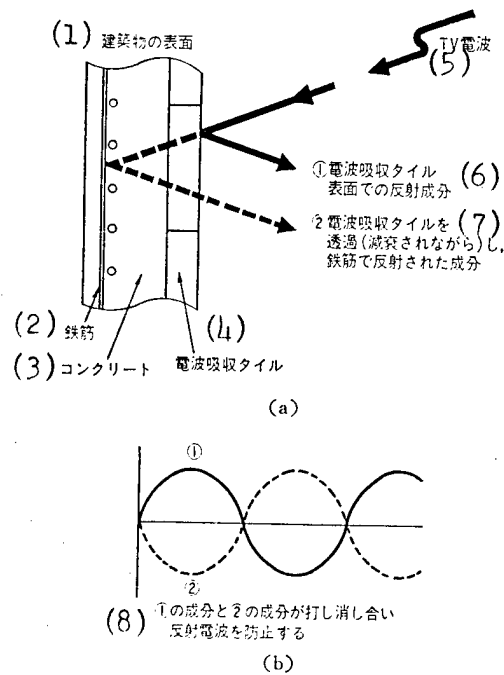

Figure 5. Operation model of a ferrite radio wave absorber.

- Key:
1. Surface of construction
 2. Steel reinforcement
 3. Concrete
 4. Radio wave absorbing tile
 5. TV waves
 6. Reflected component from TV wave absorbing tile
 7. Component transmitted (with attenuation) through radio wave absorbing tile and reflected by steel reinforcement
 8. Components (1) and (2) cancel each other and prevent reflected radio waves

This is to say, the incoming radio waves (TV waves) incident on the wall surface made up of ferrite tiles are separated into a primary reflection wave component which is reflected from the ferrite tile surface and a component that is a transmitted radio wave which penetrates to the interior of the ferrite tile. The transmitted wave is reflected by a reflecting body at the back face of the ferrite and is attenuated through ferrite loss as it becomes a secondary reflected wave and is radiated from the ferrite surface. As seen in Figure 5 (b), the amplitudes of these primary and secondary reflected waves are the same, and when their phase difference is 180°, the two waves annihilate each other and result in 0 reflection. This condition is determined by the multiple magnetic susceptibility ($\mu_r = \mu_r' - j\mu_r''$), the magnetic loss ($\tan \delta = \mu_r'' / \mu_r'$), and the thickness of the ferrite tile.

The thickness of the VHF absorbing ferrite tile that was developed is 7.5 mm, and the radio wave absorbing properties of the type shown in Figure 6 are

incorporated. Its reflection attenuation in the VHF TV frequencies is more than 20 dB. That is to say, it has a reflection rate less than 1 percent and has superior property in preventing ghosts.

The operating principles described above serve as the basis for the development of various radio wave absorbing material for construction use also taking into consideration preparation methods.

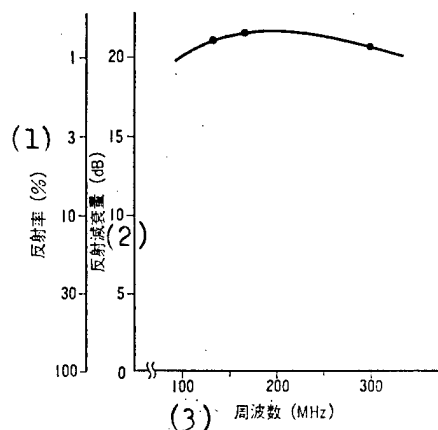

Figure 6. Frequency characteristics of radio wave absorbing wall.

- Key: 1. Reflection rate (%)
 2. Attenuated reflection (dB)
 3. Frequency (MHz)

IV. Radio Wave Absorbing Material for Building Use

Radio wave reflection from high-rise buildings is claimed to be the principle cause of TV ghost interference. Even when a ferrite radio wave absorber is used as the coating material over the outer walls of a building, the use of ferrite building material as is without modifications, as illustrated in Figure 4, makes it difficult to attain the desired effect. Since the ferrite is mounted only with the use of an adhesive, its installation on the outer wall outside of a building where temperature changes are severe can result in the hazard of the ferrite plate peeling away and falling off the wall. In addition, there is a major problem in installing it on a concrete wall. There must be practical construction taking into account finishing methods for this building material.

1. Drainboard Type Radio Wave Absorbing Wall (Continuous Magnetic Field Type Ferrite Radio Wave Absorbing Wall)

Ferrite is a magnetic material, and it has the property common to magnetic materials that when the direction of the magnetic field becomes discontinuous, it suffers great deterioration in magnetic properties. As a result, it becomes necessary to paste the tiles close together so that the magnetic field does not become discontinuous and thereby prevent this deterioration in magnetic property. In another direction, TV waves are propagated in a

horizontally polarized manner. That is to say, the electric field component is propagated perpendicular to the earth's surface.

Directing attention to this polarized wave characteristic, the "drainboard type radio wave absorption wall" construction in which ferrite tiles are pasted close together in the direction of the magnetic field, as illustrated in Figure 7 (a), becomes possible. Open spaces at the rate of about 35 percent in the direction of the electric field have been found permissible by adjusting the thickness of the ferrite tile, by which means reflection attenuation of the order of 20 dB or more can be assured. In this type of construction it is also possible, in addition to fixing the tile simply with adhesive, to use a metal channel to hold the tile mechanically, as illustrated in Figure 7 (b). An example of a curtain wall construction based on this design which was test produced as a radio wave absorbing wall is illustrated in Figure 8.

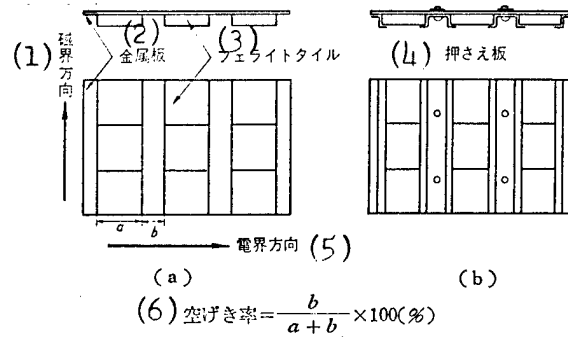

Figure 7. Construction of continuous magnetic field type (drainboard type) radio wave absorption wall.

- Key:
1. Direction of magnetic field
 2. Metal plate
 3. Ferrite tile
 4. Cap plate
 5. Direction of electric field
 6. Space ratio = $b/(a + b) \times 100 (\%)$

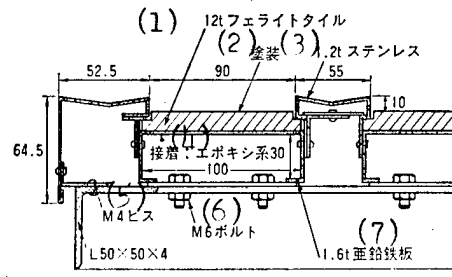

Figure 8. Curtain wall radio wave absorbing wall.

- Key to Figure 8:
1. 12 t ferrite tile
 2. Paint
 3. 1.2 t stainless
 4. Adhesive: epoxy family 30
 5. M4 screw
 6. M6 bolt
 7. 1.6 t galvanized iron

2. Concrete Composite Radio Wave Absorbing Wall

The electric properties of concrete vary with the moisture content, but they generally are in the range of 5-7 dielectric constant. At a thickness of about 20 mm, which is the thickness commonly used, there is only about 10 percent reflection of VHF waves. On the other hand, where reinforced concrete is involved, the steel reinforcement becomes a reflector, and the concrete begins to assume the role of a perfect reflector just as a metal plate. A lattice type steel reinforcement forms a reflecting body when the spacing (pitch) is very small compared to the wavelength. A pitch of about 200 mm represents the limit at which this type construction can serve as a reflector of VHF (this depends on the effective spacing of the steel reinforcement in case of a double reinforcement with mutual offset).

In order to place ferrite tile on reinforced concrete to serve as a radio wave absorbing body, the steel reinforcement should be treated as a completely reflecting body, and a dielectric material with dielectric constant of 5-7 (concrete in this case) should be sandwiched between the ferrite tile and the reflecting body in a composite construction that needs to be adopted in the design. Even in this type of construction, the control of the thickness of the ferrite tile makes possible the design of a superior radio wave absorbing wall. For example, assuming a concrete wall thickness of the ferrite tile should be 10 mm. One example of this construction is the precast concrete type radio wave absorbing wall suitable for curtain wall construction for use in high-rise construction as shown in Figure 9.

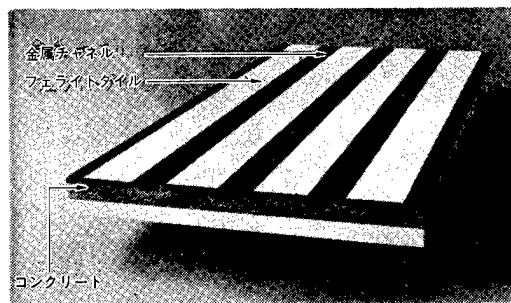

Figure 9. Precast concrete type radio wave absorbing wall.

- Key:
1. Metal channel
 2. Ferrite tile

3. Three-Layer Radio Wave Absorbing Wall

A design which takes into consideration weatherability, wind pressure resistance, and external appearance of a direct outer wall for medium high-rise construction is that of a three-layer type radio wave absorption wall in which the ferrite tile is sandwiched between asbestos-calcium silicate boards. An example is shown in Figure 10. Asbestos-calcium silicate boards are used to hold the ferrite tile between them, and a reflector also serving as reinforcement in the form of 0.8 mm thick aluminum plate is pasted on the back side. Another asbestos-calcium silicate plate (6 mm) of very high reliability is placed on the surface of this panel to further improve the weatherability and strength. This construction results in about 5 dB less performance compared to ferrite tile by itself, but adequate radio wave absorption property (about 15 dB) has been obtained (12).

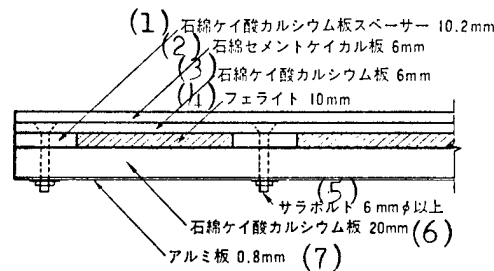

Figure 10. Three-layer radio wave absorption wall.

- Key:
1. Asbestos-calcium silicate plate spacer 10.2 mm
 2. Asbestos-cement-calcium silicate plate 6 mm
 3. Asbestos-calcium silicate plate 6 mm
 4. Ferrite 10 mm
 5. Countersunk bolt 6 mm or more
 6. Asbestos-calcium silicate plate 20 mm
 7. Aluminum plate 0.8 mm

V. Concluding Statements

The impact on today's information-oriented society by TV through its news, education, and entertainment areas is immeasurable; the new construction material introduced here which incorporates radio wave absorption property is not simply a construction material of the type used in the past but can be used to improve this information medium. The oxide magnetic material "ferrite" which is widely used in information equipment as a loss and high dielectric constant material in the high frequency region is now being reassessed as construction material and is also an illegitimate offspring in this information oriented society.

Construction material with radio wave absorbing property can be represented by concrete, which has been in wide use for a long time. Some examples are: spherically shaped granular inorganic material into which carbon black or iron carbonyl powder mixed is pasted over followed by a cement mortar family

compound type sticky adhesive to form black or board type radio wave absorber for construction use (13); ferrite particles with the mean particle size greater than $60\mu\text{m}$ mixed in as one component of the concrete aggregate which has been reported (14); and the recent report of the use of carbon fiber or carbon beads to form concrete type radio wave absorbing material with compressive strength greater than 250 kgf/cm^2 (15).

This paper was directed at TV ghost interference prevention countermeasures centered mainly on radio wave absorbing material; however, this problem is not limited to TV ghosts, but also applies to shipping radar pseudo images which plague the Honshu-Shikoku ferry; the reflection problem from structures is a major social problem covering a wide range of TV frequencies. The construction materials problem similar to the dynamics and structural science requirements of the past requires new designs which incorporate characteristics such as those relating to radio waves which together with the development of new materials point the way to the subjects to be taken up in the future.

Bibliography

- (1) Ito TV Zasshi, 29, 4 (1975).
- (2) Endo, Proc 58th Symposium (Ministry of Postal Services Japanese ITV Conference (July 1975).
- (3) Akita, Kenchiku to Gijutsu, Shiko, (5) (1981).
- (4) Japan Broadcasting Association, "Handbook for Radio Wave Interference Countermeasures with Radio Wave Absorber," (1981-1982).
- (5) Suetake, et al., Shingakukai, Microwave Research Data (January 1967).
- (6) Naito, et al., Shingakuron (B), 52-B, (11) 26 (1967).
- (7) Naito, et al., Shingakuron (B), 52-B, (7) 398 (1969).
- (8) Ishino, et al., 1974 Shingaku Zendai, 933.
- (9) Yamashita, et al., Shingakuron (B), 561-B, (8) (1978).
- (10) Akita, et al., Television Gakujutsuho, RE 77, (5) (1977).
- (11) Ishino, et al., Oyo Butsuri, 43 (11) 71 (1974).
- (12) Nippon Asbestos (Co) Technical Data, "Radio Wave Absorbing Panel."
- (13) Patent Disclosure 1970-25625.
- (14) Patent Disclosure 1977-27355.
- (15) Shimizu, et al., Shingaku Giho, EMCJ 81-71 (Dec 1981)

9923

CSO: 4106/163

END