

263122

JPRS 81455

5 August 1982

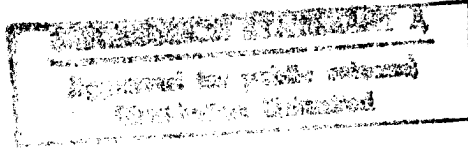

19980902 136

# USSR Report

MILITARY AFFAIRS

No. 1696

AVIATSIYA I KOSMONAVTIKA

No. 1, January 1982



FOREIGN BROADCAST INFORMATION SERVICE

REPRODUCED BY  
NATIONAL TECHNICAL  
INFORMATION SERVICE  
U.S. DEPARTMENT OF COMMERCE  
SPRINGFIELD, VA 22161

14  
60  
A05

## NOTE

JPRS publications contain information primarily from foreign newspapers, periodicals and books, but also from news agency transmissions and broadcasts. Materials from foreign-language sources are translated; those from English-language sources are transcribed or reprinted, with the original phrasing and other characteristics retained.

Headlines, editorial reports, and material enclosed in brackets [] are supplied by JPRS. Processing indicators such as [Text] or [Excerpt] in the first line of each item, or following the last line of a brief, indicate how the original information was processed. Where no processing indicator is given, the information was summarized or extracted.

Unfamiliar names rendered phonetically or transliterated are enclosed in parentheses. Words or names preceded by a question mark and enclosed in parentheses were not clear in the original but have been supplied as appropriate in context. Other unattributed parenthetical notes within the body of an item originate with the source. Times within items are as given by source.

The contents of this publication in no way represent the policies, views or attitudes of the U.S. Government.

## PROCUREMENT OF PUBLICATIONS

JPRS publications may be ordered from the National Technical Information Service (NTIS), Springfield, Virginia 22161. In ordering, it is recommended that the JPRS number, title, date and author, if applicable, of publication be cited.

Current JPRS publications are announced in Government Reports Announcements issued semimonthly by the NTIS, and are listed in the Monthly Catalog of U.S. Government Publications issued by the Superintendent of Documents, U.S. Government Printing Office, Washington, D.C. 20402.

Correspondence pertaining to matters other than procurement may be addressed to Joint Publications Research Service, 1000 North Glebe Road, Arlington, Virginia 22201.

Soviet books and journal articles displaying a copyright notice are reproduced and sold by NTIS with permission of the copyright agency of the Soviet Union. Permission for further reproduction must be obtained from copyright owner.

JPRS 81455

5 August 1982

# USSR Report

MILITARY AFFAIRS

No. 1696

AVIATSIYA I KOSMONAVTIKA

No. 1, January 1982



FOREIGN BROADCAST INFORMATION SERVICE

5 August 1982

USSR REPORT  
MILITARY AFFAIRS

No. 1696

AVIATSIYA I KOSMONAVTIKA

No. 1, JANUARY 1982

CONTENTS

AIR FORCES

'AVIATSIYA I KOSMONAVTIKA' No 1, 1982: Table of Contents.....	1
Flight Schools: Current State of Air Force Schools Discussed (G. Dol'nikov).....	3
Transport Training: Flight Safety Discussed (V. Shishkin).....	11
Bomber Training: Radar Avoidance Tactical Training Discussed (N. Stremous).....	17
Flight Schools: Fighter Tactical Training at Chernigov School for Combat Pilots (O. Podryadchikov).....	21
Helicopter Training: Flight Engineers Discussed (V. Fadeyev).....	26

Flight Training: Use of RSBN-6S Navigational Device Discussed (V. Polonskiy).....	29
Flight Training: Emergency, Gear-Up Landings Discussed (A. Berezin).....	35
Flight Training: Simulator for Aerial Combat Discussed (S. Gribanov).....	39
Combat Training: Role of "Zapad-81" Reportage Discussed (Yu. Belyayev).....	42
Technical Services: Helicopter Flight Preparations Discussed (G. Chaplygin).....	46
Technical Services: Innovator's Work Discussed (A. Makarov).....	51

AIR FORCES

'AVIATSIYA I KOSMONAVTIKA' NO 1, 1982: TABLE OF CONTENTS

Moscow AVIATSIYA I KOSMONAVTIKA in Russian No 1, 1982 (signed to press 2 Dec 91)

/Table of contents of AVIATSIYA I KOSMONAVTIKA No 1, 1982/

/Text/

Table of Contents

Dol'nikov, G.	The Present State of Air Force Military-Educational Institutions .....	1
Shishkin, V.	A Systems Approach .....	4
Stremous, N.	Mission Received in Flight .....	6
	The Bookshelf .....	7
Podryadchikov, O.	"Sensitive to People, Reliable in Work" ....	8
Kuznetsov, A.	Military Relay Race .....	9
Mazur, V.	Strengthening the Discipline of Accomplishment .....	10
Drobiyaka, I.	And with an Inviting Word .....	11
Trushchev, Yu.	Ideological Tempering is Growing Stronger .....	12
	Short Miscellaneous Subjects .....	--
Vakhnov, I.	With Long Distance Routes .....	14
Fadeyev, V.	Flight Technician .....	--
Ryabokova, G.	The Right to Lead .....	16
Andreyev, N.	In the Direction of Fire .....	17
Monastyrskiy, B.	Strike Attacks .....	18
Il'in, N.	Through All Trials .....	19
Korabl'skiy, G.	The Earth Rushed Headlong to Meet Us .....	20
Kadet, M.	From the Tribe of the Winged .....	21
Grigor'ev, A.	An Hour Before Dawn .....	--
Polonskiy, V.	". . . Plus Navigational Training .....	22
	With Combat Tuning .....	24
Berezin, A.	Landing . . . with a Retracted Landing Gear.....	26
Volodin, D.	Weather Service .....	--
Tkachev, A.	The Wings of Initiative are Growing Stronger .....	28
Gribanov, S.	The "Projector-Target" Apparatus .....	29
Belyayev, Yu.	Experience of the Leaders .....	30
	Try and Solve It .....	32
Chaplygin, G.	Attitude Towards the Task Explains It .....	--
Makarov, A.	An Inventor Submitted a Proposal .....	34
	Compare Your Solutions .....	35
Shamshin, V.	The Depth of Search .....	36

Kadgrov, R. and Volkov, A. . . . .	Toward Longevity in Flying . . .	37
Bookshelf . . . . .		--
Ponomarev, A. . . . .	Scientist and Researcher . . . . .	38
Solodovnikov, A. . . . .	With a High-Altitude Flying Suit . . . . .	--
Kuchumov, V. . . . .	Space Photography . . . . .	40
Bookshelf . . . . .		41
Lyndin, V. . . . .	With our Bulgarian Friends . . . . .	42
Our Mailbox . . . . .		--
Bookshelf . . . . .		43
Konykov, N. . . . .	Space-Age Metals . . . . .	44
Bookshelf . . . . .		45
Romanov, V. . . . .	The "Assault Breaker" System . . . . .	46
Foreign Aviation and Space News . . . . .		47

COPYRIGHT: "Aviatsiya i kosmonavtika", 1982

11350

CSO: 9144/0605

## AIR FORCES

### FLIGHT SCHOOLS: CURRENT STATE OF AIR FORCE SCHOOLS DISCUSSED

Moscow AVIATSIYA I KOSMONAVTIKA in Russian No 1, 1982 (signed to press 2 Dec 81) pp 1-3

/Article by Colonel General of Aviation G. Dol'nikov, Hero of the Soviet Union, USSR Honored Military Pilot: "The Present State of Air Force Military-Educational Institutions"

/Text One of the main tasks of Air Force academies and schools is to improve the training and education system and to seek ways of raising the quality of training aviation cadres.

Rapid developments in science, engineering, and in aviation combat application methods make ever greater demands with each passing year on the work done by higher and middle military educational institutions and on the level of training of newly-graduated officers.

A resolution of the Central Committee of the CPSU and the Council of Ministers of the USSR "On the Further Development of the Higher School and Raising the Quality of Specialist Training," stated that the main focus of the higher school should be concentrated on an all-round improvement in the quality of professional training and ideological-political education of specialists, on strengthening ties with production, and on the practice of building communism.

Air Force academies and schools are, on the whole, successfully fulfilling these established tasks. State examinations of 1981 witness the fact that many higher educational institutions achieved high qualitative grades, and the level of professional training for their graduates has risen. Having received solid knowledge and skills, the young officers are capable of quickly learning their jobs and, successfully--knowing what they are doing--participate in unit combat and political work. In this, a great deal of credit goes to the directing and professorial-teaching staff and instructors, who give all their knowledge and experience to the noble task of training and educating aviation cadres.

The training of worthy replacements at all developmental stages of aviation has always occupied a special place and has been one of the most complex and pressing tasks. And this is natural, because developments in aviation engineering are closely tied in with converting the latest achievements in scientific-technical thought and military affairs into operational capability. Naturally, only well-trained specialists can competently exploit such technology. At the present time, the Air Force is equipped with the most modern aircraft and helicopters which can accomplish complex and critical missions. The officer-aviator of today, as never before, needs all-round knowledge and skills, high moral-combat qualities, physical endurance, and psychological stability.

Military aviation educational institutions of the Air Force have at their disposal everything necessary for providing basic training to pilots, navigators, engineers, technicians, and other specialists in response to current requirements. A large contingent of officers having academic degrees and ranks, as well as a great deal of experience in working in military units, is working in academies and schools. At the same time, in order that the level of knowledge of this academic and academic-pedagogical staff respond to the spirit of the times, necessary conditions are created to improve their special and methodological training. To do this, combat units, as well as repair plants and departments of leading institutions of higher education, have regularly-scheduled training periods. Academies have courses to raise qualification levels, and starting this year there will be courses for beginning instructors. Many instructors are attracted to participating in various studies and in scientific research on problems of how to increase the combat readiness and capability of aviation units and subunits. The directing staff of institutions of higher education annually visits combat units for familiarization with on-site teaching of new materials and combat readiness, especially of young officers, with regard to new aviation technology, and studying positive experiences and shortcomings. This gives the opportunity to organize the work of military-educational institutions on the level of current needs, and to operationally introduce into the educational-training process everything new and contemporary that appears as a result of research, study, and daily practice in units. In this respect, the main thing right now is the study and introduction of the experience gained in the exercise "Zapad-81," conducted by Marshal of the Soviet Union D.F. Ustinov, Minister of Defense of the USSR.

One of the important directions to take in raising the quality of training of the officer cadres is to conduct systematic scientific research in the educational system on various specialties and on specific, key problems of the educational-academic process. As a result of such work in recent years, schools have more precisely defined the structural-logical ties in the teaching of

academic disciplines, complex plans have been introduced for communist education for students, as well as programs for developing their command, and systematic habits and skills for conducting political-educational work. Complex auditoriums and laboratories--and much more--are being created. Scientists from academies are actively participating in this work, which increases the authority and raises the level of research work. Scientific research on problems of increasing the effectiveness of training and education will be conducted on a broader scale in the future. Life itself demands nothing less.

In raising the general level and quality of educational and scientific work of flying, engineering, and technical schools, a large role belongs to the academies. At the present time they have become unique scientific-methodological centers: For example, the Yu. A. Gagarin Air Force Academy, in training its command flying cadres, the Professor N. E. Zhukovsky Air Force Engineering Academy, in training its engineering flying cadres. It is worth noting the exclusively useful initiative of the directing staff of the engineering academy in connection with transforming a number of middle technical schools into higher schools. As is known, the formation of any institution of higher education is tied to specific difficulties and takes a rather long period of time. In order to accelerate and facilitate this process, the specialists of academies and schools have developed a special plan to give assistance in organizing academic and methodological work by developing scientific research work and training scientific-pedagogical cadres for these schools. This creative cooperation has already brought positive results. The new engineering schools are gathering strength, and there is every reason to believe that their graduates will receive all the knowledge and skills that are necessary for officer-engineers.

The practice of revising study plans and programs after completing a full cycle of teaching students has justified itself. This gave the opportunity to use more fully the latest achievements of science and technology, military pedagogy and psychology, to take stock of the work experience of the students, and to make certain that the correct perspective is being placed on the training of cadres. Notwithstanding the great and goal-directed work of specialists in institutions of higher education, there are still many problems which need to be resolved in the organization and methodology of education. For example, there is still a shortcoming in the leading institutions of higher education throughout the country in steadfastly learning about organizing a close relationship between education and production. But, concealed in this is a large reserve for further increasing the effectiveness of the educational process and matching the training of graduating specialists with the needs of the armed forces. Problem-solving methods are poorly inserted into the academic process. Many directors, department heads, and instructors

have not yet formed their views on this problem. Not fully resolved is the problem of a fundamental change in the independent work of students and cadets, and more active seminar and laboratory studies as effective forms for reinforcing knowledge and for manifesting the creative capabilities of the students. Not everything possible is being done to teach the students and cadets to acquire the necessary knowledge independently.

The most complex and labor-intensive process is that of training pilots and navigators. Over twenty years have passed since flying schools were reorganized into higher-level schools. A great deal of experience in training flying personnel has been accumulated in that time. Officer-pilot (navigator)-engineer are three terms which express the essence and trend in training the modern air fighting man.

How more complex the training process is becoming because of new technology in the inventory is especially noticeable in flying schools. The basic indicator of the professional attainment of pilots and navigators remains the flight training which they receive during their studies. The high degree of flight training received by the graduates is a guarantee that they will quickly be assimilated into the ranks and into training that will prepare them for conducting military actions. In recent years, cadet flight training, in training and combat aircraft, has increased significantly. However, the introduction of aircraft that are more complex to fly and operate has necessitated a greater increase in flight training. How can this be done? One would think that the real strength is embodied in the rational utilization of aircraft and helicopters, optimal use of air space, improvements in directing and controlling cadet flights, and in well-thought-out and scientifically based development of flying programs. One of the most important research tasks of higher flying schools is to find possible ways and means of increasing flight training. At the same time, flight training is a special and most complex type of training. By and large it is tied to resolving the problem of how to increase flight safety, and it requires an all-round consideration of the individual capabilities of cadets, and their basic training in the theoretical, practical, and psychological relationships. This is why the selection and training of pilot-instructors demand higher requirements.

Our schools have highly-trained flight instructor staffs. The majority of them are First and Second Class pilots and navigators. Among the best, one can name pilot-instructors from various schools: Major R. Ustinov, Captains N. Zaporozhets and A. Finyachkin, Senior Lieutenants A. Chmyrikov and V. Pakhomov. Professional training is being developed knowingly by navigator-instructors, Captains V. Borisenko, A. Nikolashin, and Senior Lieutenant A. Shevelev. And although the majority of instructors

carry out their duties in an excellent manner, it occasionally happens that special qualifications unfortunately are not yet always reinforced by an increase in the mastery of the methodology. The training system and the determination of whether the cadet is ready to successfully complete his flight are actually extrapolated from the above factors. One of the vital tasks of flying schools is to raise the level of knowledge of the instructor staff in questions of military pedagogy, training methodology, and the psychology of flying. Another serious shortcoming is the system of control over the preparedness of cadets to fly in general and to accomplish specific missions, in particular. It is necessary to seriously think about developing special computer-controlled apparatuses that would provide an objective control over the flight readiness of each cadet.

A most important component in the training of today's officer is all-round physical development of students and cadets during the course of training. Special attention in this regard is paid to physical training--the hardening of air fighters. Modern warfare is accompanied by great stress. The victor will be the one who, together with a high degree of flying mastery, will have a large reserve of strength. A flyer who is insufficiently developed in the physical and moral sense is not capable of conducting stressful combat operations or knowledgeably piloting an aircraft at a pace approaching its outer limits and having great variable and prolonged overloads. As a result of not being able to take it, he will involuntarily limit the maneuverable capabilities of the aircraft and will not fully utilize its flying-tactical characteristics. It is essential to persistently improve the system of physical training for flyers, as well as the system for conducting studies, so as to instill a love for sports on the part of the students.

The training of students and cadets is closely connected to their ideological and military education. The education of winged defenders is being conducted along the best traditions of the Soviet Army and Air Force, and is directed at forming, in future officers, a Marxist-Leninist world outlook, a devotion to the Communist Party and the Soviet people, and a readiness--in any situation--to fulfill their duty to the Fatherland to the utmost. At the root of all educational work in institutions of higher education is the requirement to fulfill the resolution of the CC CPSU "On the Further Improvement of Ideological and Politico-Educational Work." Constant attention to this problem and a creative search for new, scientific forms and methods results in the successful training of officer cadres.

The development of high moral-political, combat, and psychological qualities in students and cadets is achieved by the entire system of training and education through daily, painstaking work on the part of teachers, instructors, and officers of cadet subunits.

However, the development of aviation engineering and methods of applying it to combat requires a further strengthening of physiological reliability and psychological stability of the officer. A great deal of work and research is being conducted in these areas. The task now consists of arming teachers, instructors, and platoon commanders with a concrete program for psychological training of cadets during flight training, studies, and various other work. At the same time, this program should incorporate all areas of activity and should grow more complex as one passes from course to course. Creating a specific program and methods for moral-psychological training of future officers will undoubtedly bring positive results.

At the present time, military-educational institutions have a developed, well-equipped educational-material base. Auditoriums, laboratories, offices, training airfields and ground training units have the necessary models of new aviation technology, equipment, and armament. During training, diverse technical means, various ground trainers, and operational systems are widely used. With the least expenditure of effort and time they facilitate an understanding of complex physical processes that go on during aviation-engineering work and during the flight of an airborne platform. However, the educational basis, just as the entire educational process, requires constant updating and improvement. The efforts of teachers and management efficiency experts are now directed toward a broader introduction of complex laboratory apparatus, video recorders for consultations, and different control equipment. A great role in developing cadet skills in working with cockpit equipment of combat aircraft is played by different kinds of ground trainers. Schools use both complex, as well as single-purpose trainers. Efficient organization of training sessions and an optimal utilization-load of this equipment, gives opportunity to each cadet--in the course of a year--to work out hard skills in piloting and operating an aircraft. Used correctly, the trainers increase the effectiveness and accelerate the training of young aviators, and bring out their characteristic, individual personalities in ordinary circumstances, as well as in imitation stress situations. Hidden within the ground trainers are vast possibilities; it is necessary to constantly study and perfect training methods, using them. The main trend in this work is to establish a close connection between training sessions and the accomplishment of specific flying missions. This will undoubtedly raise the level of training for cadets and pilots and, consequently, will increase flight safety.

A new academic year has begun in military-educational establishments. It was preceded by a large amount of preparatory work. Academies, schools, and educational subunits minutely analyzed the results of the preceding year. They studied the reasons for shortcomings and noted concrete steps to correct them. All that is new

and progressive, and provides an opportunity to increase the effectiveness and quality of training, is brought into operation.

The volume and complexity of problems being resolved by institutions of higher education increase each year. The success of the work and the final results of work in the new year will depend mainly on the organizational activity of commanders, chiefs of staff, and political organs responsible for signing up servicemen to fulfill high-quality plans for combat and political training. At the basis of all activity of the staffs of higher educational institutions lie the requirements of the XXVI Congress of the CPSU. In actualizing the party decisions and the instructions of comrade L. I. Brezhnev, General Secretary of the CC of the CPSU and Chairman of the Presidium of the Supreme Soviet of the USSR, commanders and political workers, and the professorial-teaching and instructor staff are doing everything they can, so that students and cadets will become not only good specialists, but also ideologically-hardened fighters of the party, and dependable defenders of the interests of the Fatherland and countries of the socialist fraternity. On the basis of a thorough knowledge of the theories of Marxism-Leninism, students and cadets should have a correct understanding of party and state decisions on questions of domestic and foreign policy, and should be able to thoroughly comprehend the complex military-political world situation.

Many schools have begun training in accordance with new training plans and programs. The task consists of clearly understanding the essence of the changes introduced into the study of disciplines. These changes have been dictated by the experience of past years and by the analyses of results of the work done by graduates in units. Rather complex problems need to be resolved by the flying schools in the new year. The main attention should be concentrated on raising the air training of cadets, on the full accomplishment of established norms for general and solo flights, on learning complex piloting--formation flying and combat applications. It is necessary to constantly raise the methodological mastery of instructors as the basis for raising the level of flight training and providing accident-free work. One should strive for the position where a first-class pilot- or navigator-instructor would also be a first-class pedagogue, a methods specialist, and a master of his profession. There is a lot to be done also for improving the organization of flying work, attaining accomplishments in all elements to the highest limits, and seeking effective systems for providing safe flights. All flying personnel should constantly, every day, be inculcated in a high degree of discipline, in being demanding of themselves and their subordinates, and in feeling impatient toward shortcomings, remembering that there are no trivial matters in aviation.

There can be no forward movement without popularizing and introducing the latest advancements into the educational process. The organization of exchange of experiences should be at the center of attention of directors of institutions of higher education, and party and Komsomol organizations. The introduction of progressive methods of training should not be on a laissez-faire basis, but should be conducted according to plan, which places a high requirement on chiefs and commanders of training subunits.

Chiefs, commanders, political workers, and party and Komsomol organizations of institutions of higher education are fully resolved to accomplish the tasks they face in training highly qualified officer cadres for the aviation of the Armed Forces. The current situation requires this, and this is our party and military duty.

COPYRIGHT: "Aviatsiya i kosmonavtika", 1982

11350

CSO: 9144/0605

AIR FORCES

TRANSPORT TRAINING: FLIGHT SAFETY DISCUSSED

Moscow AVIATSIYA I KOSMONAVTIKA in Russian No 1, 1982 (signed to press 2 Dec 81) pp 4-5

/Article by Lieutenant Colonel V. Shishkin, Military Pilot First Class: "A Systems Approach"/

/Text A heavy military transport aircraft, piloted by Pilot First Class, Major V. Petrushin, was making an approach for a landing at an airport on a high mountain. The crew was doing what it had done many times before. Meteorological conditions were good and everything, as they say, was going according to schedule.

Problems arose after the crew's navigator made an error in determining the moment when the turn should be made for the landing approach. As a result, the aircraft turned out to be significantly higher in altitude than the designated glide path. Hoping to correct the miscalculation of the navigator, the crew's commander pulled up on the stick and changed the engine rate. The first to say anything was the copilot:

"We won't make it. We'd better go around a second time."

"What do you mean, we won't make it," retorted the commander, "It's a big runway!"

Major Petrushin also did not heed the navigator's words and continued dropping in altitude at an unauthorized vertical rate. Neither did he react to the order of the flight controller about going around a second time. The aircraft passed over the end of the runway at a high altitude and speed. The situation became quite complex, but not hopeless. The good landing characteristics of the aircraft made it possible to terminate the flight successfully. But in this situation, the pilot had not acted confidently. Only seven seconds after landing he cut back the engine control throttle all the way and gave the command to brake the aircraft with the propellers. The chain of crude errors by the crew and, first of all, by the commander, led to the heavy aircraft rolling past the

end of the runway at a great speed onto unprepared sod.

Was this incident a chance occurrence? This was the question the experts asked themselves in investigating the incident. As it turned out, this landing was the logical conclusion of the pilot's deep-seated error in the technique of flying and his inadequate moral-psychological training. Prior to this, Major Petrushin had displayed conceit and too much self-confidence, and had several times landed an aircraft beyond the point of a precise landing. During one such landing, attempting to stop the aircraft within the bounds of the runway, he applied emergency brakes and, as a result, completely "stripped" them.

This incident underlines the fact that not only was the pilot not sufficiently trained, both professionally and psychologically, but more importantly, that his immediate superiors had no knowledge of his individual personality. Class, general flying, and flights during the preceding month undoubtedly are important indicators of a pilot's qualifications. But they do not provide a sufficiently complete picture of his actual level of readiness and training.

In order to have safe flights, the initial and most essential part lies in the analysis of the quality of a pilot's flight training and his individual personality. The most important of these are indicators of piloting techniques and moral-psychological stability. In turn, the quality of flight training is characterized by the number and relative importance of allowed errors. The fewer the errors, the higher the quality of piloting and reliability of a pilot's actions. Statistics show that on the average, for every tendency toward a flying incident, there are ten gross errors in piloting techniques.

An error is a chance phenomenon and has a characteristic of probability. No one is insured against error. But the probability of errors committed by different pilots has its own limits. In other words, every pilot has his own coefficient of reliability that depends on flying experience, age, psycho-physiological characteristics, extent of training in basic aspects of flight training, and the level of work capability during a flying shift, and especially under extreme conditions. A successful flight in many ways is determined by the reserve capabilities of a pilot, his neuro-emotional stability, and his ability to function precisely and with knowledge in extraordinary situations. Experience has shown that a pilot's individual characteristics will come out most clearly during a complex situation.

No matter how perfect a training system may be, each pilot has something of his own that manifests itself when he is performing various flying functions. Individuality is an objective factor depending on intellectual and psycho-physiological characteristics

of a person. Thus, it is for all practical purpose, impossible to achieve an absolutely identical result when completing some stage of flight, say a landing. It is another matter to try to adhere to given flight parameters within specified limits which would result in a safe and precise landing. It is not by accident that our different types of aircraft have their own parameters. In connection with the above, a problem that deserves attention is that of learning the factual situation of a specific pilot's air training, his capabilities, and his individual characteristics based on a statistical analysis of quantitative and qualitative data of his flying work.

As a rule, a pilot's professional training is evaluated by the results of testing him in the air and in ground trainers, data from the objective control system (SOK), and written comments by personnel assigned to groups in charge of flight training. For a commander these are, so to speak, basic information sources on an aviator's training. Let us examine them in greater detail.

Experience has shown that the most effective method for testing the quality of a pilot's training is the flight check, with a subsequent analysis of given on-board and ground SOKs. An instructor's evaluation is always subjective, which is dependent upon the characteristics of the undertaking, and by his processing and remembering information relative to the activities of the pilot during his flight. It is impossible for him to remember all deviations, compare them with the norms, and determine evaluations for every phase of the flight. Norms are complex to remember, so the instructor evaluates the work of the pilot based on a general impression. In addition, not an insignificant role is also played here by his personal relations with the student, strengthened by emotional experiences. On the other hand, comparing his impressions with SOK data, the instructor can make more substantiated conclusions. Concurrently, the SOK data provide him and the pilot the opportunity to reveal errors that would have remained unnoticed without instrumental means of testing.

The effectiveness of pilot flight testing may be substantially higher when the aircraft has auxiliary equipment installed (video tape recorder, dictaphone, and apparatus for measuring physiological parameters). The simplest method is to voice-record a pilot's errors on a dictaphone. But, to take notes on a lap plotting board is useless, because the instructor would be distracted constantly from controlling the test by having to maintain the given flight plan. And in cases where the operational seats of the pilot and instructor are side by side, and the student sees the instructor writing something, there is an unfavorable psychological impact on the student. Installing additional equipment on the aircraft and using the data from instrument controls would do away with an instructor's subjective evaluation,

and would resolve the problem of studying the individual qualities of pilots and, consequently, of insuring safe flights.

Unfortunately, the number of controlled flights is small, even for an experienced pilot. For this reason, another important source of information consists of airborne and ground SOKs. There is no doubt about their advantages. Still, the main shortcoming of this control method lies in its relatively insufficient exactness and efficiency, which are caused by deficiencies in existing SOKs and the limited capability of objective control groups to process the data. As a result, the commander has only a part of the objective information when he makes up his planning chart for the rotational flight shifts. In other words, a significant part of infractions and errors allowed by aircrews remains undetected. In turn, errors in planning flights due to a lack of reliable information create a threat to flight safety.

An automated system for processing flight data, type LUCH-74, makes it possible to increase the efficiency of objective control. Another method is to plan for the application of SOK with consideration of the differences of a specific flight rotation and making use of these differences in a rational way. A comparative analysis of the capabilities of on-board automatic recorders and deciphering apparatus shows that the required time for processing information from a one-hour flight is not identical. For example, while processing notes by a KZ-63 automatic recorder takes five minutes, the time increases to two-three hours when using a MSRP-64 and decoding devices. Experience has shown that it is logical to use low-informative SOKs for "surveying flights," which do not require a great deal of time to decode data. And high-informative apparatus of the MSRP type should be used for a detailed analysis of flight stages which have been detected to have deviations through the use of simpler SOKs.

A rational and comprehensive utilization of existing methods of objective control at key points of a flight (take-off, approach, landing, line of attack, etc.), and planning their application together with a consideration of the characteristics of a specific flight schedule and the aircrews, create favorable conditions for determining the actual quality of how flying missions are fulfilled.

Commanders receive important information from observations by members of groups directing flights. The greatest value, from the point of analyzing the technical quality of a pilot's take-off and landing, is the information given by the deputy director of flights. Research carried out in our unit shows that the scope and quality of information from the deputy director of flights substantially increases when he is optimally active in the flight scheduling process. The results of his work are substantively better when he precisely enumerates the elements to be evaluated, when he uses a special journal, and when he uses a video tape

recorder and dictaphone.

An important point in evaluating a pilot's professional training and his reserve capabilities is the special check on a piloting ground trainer, using a "Fiziolog" type apparatus for recording physiological parameters. Flight conditions and accident situations can be simulated, which would be virtually impossible to create during an actual flight. The tester has everything he needs to bring out a pilot's reserve capabilities and his individual characteristics. The results of such tests, with the recording of physiological parameters, substantially add to a pilot's flight characteristics.

In general, based on one check flight, it is difficult to judge the level of a pilot's professional training and the reasons for his committing of errors. To do this, it is necessary to analyze a large volume of dependable information from various sources on flight quality over a certain period of time. Analysis seeks two objectives: to determine the actual quality of training and to detect individual characteristics; and to determine the reasons for errors committed, and to work out measures for eliminating them.

The actual level of professional training is dynamic and is characterized by many interrelated indicators which have different weights and significance. These relations and their most important aspects can be determined only with the help of mathematical analysis. At present, for measuring and analyzing the quality of aircrew training, numerous graphics, journals, cards, etc. are used. The large quantity of such documents and reports engender elements of formalism and bureaucracy. Abstract data, as a rule, and very high scores on pilot techniques, do not clarify the true state of affairs. Behind the score one cannot see the real pilot and his personality, capabilities, and preferences. Thus, information should have a specific form that is easy to learn. Mini-computers can render substantive assistance in this matter.

Thus, a comprehensive approach is needed to deal with the matter of perfecting the system for analyzing the quality of flight training. The natural basis for such a system, as hypothesized, should be on-board and ground SOKs, instruments of the LUCH-74 type to automatically process flight data, an aircraft equipped with auxiliary instruments, a ground trainer with a "Fiziolog" apparatus, and a mini-computer. This will permit a full operational analysis of the quality of all completed flights (testing and detailed analysis of elements). Operational data provide the opportunity to discern errors, prevent their repetition, and foster a positive attitudinal change toward flying incidents. And the quicker measures are taken, the better. The use of these materials by student pilots for purposes of self-analysis when their memories still carry fresh impressions of their completed flights will raise the effectiveness of training.

In addition, processing the information over a specific period of time provides the opportunity for revealing pilots' individual characteristics in their piloting techniques, determining the true quality of their training, finding the reasons for their errors and analyzing their manifestation, and improving the process of combat training. Perfecting the analytical system would permit an individual approach to training every pilot. It would stress his shortcomings in flying techniques and exclude from the program those elements of training that were well performed. In turn, this will provide an opportunity to raise the effectiveness of the flight training process, save the expenditure of material resources, and substantially improve preventive work in providing flight safety.

Arming commanders and staffs with modern organizational systems, as well as hardware for storing and processing information (above all, electronic technology) are indispensable conditions for interrelating science with the process of combat training.

COPYRIGHT: "Aviatsiya i kosmonavtika", 1982

11350

CSO: 9144/0605

AIR FORCES

BOMBER TRAINING: RADAR AVOIDANCE TACTICAL TRAINING DISCUSSED

Moscow AVIATSIYA I KOSMONAVTIKA in Russian No 1, 1982 (signed to press 2 Dec 81) pp 6-7

/Article by Colonel N. Stremous, Military Navigator First Class:  
"Mission Received in Flight"

/Text As the meteorologists had predicted, the weather worsened. Dark grey clouds raced low over the earth and a cold rain drizzled off and on. It would appear that there could not be even any talk about conducting flights. Nevertheless, life went on as usual in the hangars. Technicians and aviation specialists were completing their readying of aircraft and armaments, and the flying personnel were receiving their pre-flight briefings. An analysis of the area forecast and the data from weather intelligence showed that notwithstanding a thick overcast, the lower edge of clouds and visibility met aircrew minimums. So, the commander decided to commence with the flights.

Green rockets streamed into the sky and the evening quiet was filled with the din of jet engines. In accordance with the flight plan, one heavy bomber after another wheeled in for the start and disappeared into the thickening twilight.

The group led by Lieutenant Colonel I. Ladyko had already been airborne for several hours. Now it approached the edge of detection of the "enemy's" radar communication line (RLS). One could not fly further at this altitude; the radar would make a fix on the airships. The bombers went down to a predetermined altitude and, skillfully using sectors of dead space where radar rays could not reach them, entered the "enemy's" rear area undetected. Calculations on how to avoid air defenses, computed before the flight, turned out to be correct.

Aircrew members are busy with their tasks, and no one allows himself even a minute of relaxation. After all, the flight is taking place under full cloud cover and over areas that cannot be used for orientation. Only calculations, a strict adherence to the given plan, and timely corrections guarantee a precise appearance over

the target.

Captain M. Apurin, navigator of the lead aircraft, is calm. This is not the first time he is on a flight that extends to the bomber's full radius of action. Having an outstanding knowledge of the capabilities of the navigational complex, skillfully using all methods and means of calculating and controlling the route, the navigator confidently corrects the system.

Having pinpointed the time when the combat flight path would begin, Apurin began to check the initial situation regarding the bomber's armament. Lieutenant A. Goncharov, the second navigator, attentively marked off his checklist point by point. Not a single wasted word; everything was being done just as it had been done on the ground trainer.

The on-board radar scope flashed a characteristic river bend. This was the control orientation point. Reconciling the factual data with the calculations, the navigator reported to the commander that the flight path is being adhered to correctly and that in several minutes the aircraft will enter the line of the combat flight path. Just at that moment, Warrant Officer Praporshchik V. Komarnitskiy's voice rang out over the earphones:

"Comrade commander, an urgent radiogram. Our target has been changed. The order has been given to strike the target in the quadrant."

"Navigator, prepare calculations for a bombing approach and for bombing," directed Lieutenant Colonel Ladyko.

"I understand."

As always, the aviators had diligently prepared for their tactical flying lessons. The navigator service had received a special mission: to develop several variants for striking a target in an unfamiliar area, and to prepare preliminary calculations in case of changes in the air and tactical situation. This work was headed by Navigator First Class, Captain M. Apurin, an experienced systems specialist. Pilots and navigators proposed various methods of approaching the target from different points along the flight path. And still, Apurin's calculations were distinguished by their great simplicity and reliability. After having avoided the "enemy's" air defenses, he proposed to fly south for a while, and then turn left and get back on course to the target. In this case the bombers would fly along a background of great cumulus clouds stretching along the last leg of the flight path and being carried away from the target by the wind. The "enemy" will have a difficult time to distinguish the group of aircraft in the last light of day. After a closer calculation and a discussion of the data, this was indeed

the basic method accepted. The commander gave a "well done."

It should be noted that in daily combat training, the leadership devotes a great deal of attention to the navigational training of aircrews and to the development in pilots and navigators of the knowledge that should be used during flights; also, methods and means of piloting an aircraft, and combat application of on-board sight-navigation instruments and weapons. No doubt that automatic navigational systems are capable of directing a ship to any desired point, no matter whether on land or water surface. And with the aid of a radar sight it can deliver a powerful strike on a target even if it is not in its visual range. In order to use all equipment knowledgeably, a thorough understanding of its capabilities is needed, as well as principles and work schedules, and solid skills. To accomplish this, units conduct planned studies which include coordination between aircrew members at different stages of a flight, and gradually work skills are formed with regard to equipment and systems.

In training subordinates, commanders pay special attention to the development of their initiative, and to their skills in orienting themselves should a difficult situation develop in the air. It is noteworthy that during the course of training in ground trainers, aviators try just as hard to work out the tasks which they have already flown several times, as they do new exercises. This allows each crew member to maintain the necessary level of mastery.

The tactical training task on changing targets did not catch Captain Apurin unaware. Quickly finding the new target on the map, the navigator mentally pictured the weather and tactical situation in the operational area. A decision came suddenly: bank left by thirty degrees and after having passed the traverse of the direction finder and concurrently going down in altitude below the "enemy's" radar detection zone, approach - undetected - as closely as possible to the target. Then - a turn into the combat course and the attack.

A radiogram flew over the airwaves:

"This is a multiple-call message! The group is to carry out a bomb strike against the target. . . . Compute the sighting data."

The bombers turned to the new target. Having evaded the air defense screens, the group entered the target area. The target indicator appeared on the screen of the on-board bomb sight.

You could hear Captain Apurin's voice saying, "Combat!"

Lieutenant Colonel Ladyko banked the heavy aircraft to the left, and it was as if it had frozen on its combat course. Now, the precision of the strike depended upon the navigator's mastery.

The seconds are counted, and the target is in the crosshairs. The automatic bomb release checked. Freeing itself of a multi-ton load, the aircraft began its turn onto a new course. One after the other, the rest of the group's aircraft entered the bombing/range.

Using the sighting data computed by the navigator of the lead aircraft, all aircrews laid their bombs right on the target. While they were still in the air, the radiomen had received a radiogram from the bomb range: "The target has been destroyed." And although it was still to take many hours to reach the airfield where they would land, everyone's mood was elated. Success took away the fatigue.

Meanwhile, at the airfield they were preparing to meet the aircrews. The bulletin board displayed a flash-message telling about the successful mission accomplishment by Lieutenant Colonel I. Ladyko's group. Especially noted were the knowledgeable and precise actions of Captain M. Apurin.

This officer's success is not accidental. After completing the Chelyabinsk Higher Military, Aviation, Red Banner, Navigator School imeni 50th Anniversary of the VLKSM, he was one of the first of his contemporaries to operationally master a bomber that was new to him and, not resting on his laurels, he persistently continued to increase his theoretical knowledge. He was often seen in study classes, library, ground trainer, and in the bomber's cockpit. Gradually his expertise grew and he amassed experience. The best methodist of the unit, Major N. Sorokin, who helped Apurin from the very beginning of his career, was happy for the tenacity and persistence of the navigator who became specialist second class and then, specialist first class, all in the shortest possible time.

In that important flight, Apurin had justified the hopes of his teacher. When the scores were added for successes achieved in combat and political training, Captain Apurin was thanked and given a valuable present in the name of the next higher command level. Many other regiment aviators also received commendations.

COPYRIGHT: "Aviatsiya i kosmonavtika", 1982

11350

CSO: 9144/0605

AIR FORCES

FLIGHT SCHOOLS: FIGHTER TACTICAL TRAINING AT CHERNIGOV SCHOOL FOR COMBAT PILOTS

Moscow AVIATSIYA I KOSMONAVTIKA in Russian No 1, 1982 (signed to press 2 Dec 81) pp 8-9

/Article by Captain O. Podryadchikov: "Sensitive to People, Reliable in Work"/

/Text/ The runway, as seen from the command control tower, is as visible as the palm of one's hand. On it sit two L-29's.

"Permission to take-off," commanded the chief air controller, and within a few minutes training aircraft soared into the sky and turned into black dots. They then disappeared completely. However, from the ground they were being carefully tracked. The board plotter received and transferred to a map the coordinates showing the position of the aircraft.

"The battle will begin now," said the chief air controller.

And he was exactly right. Major A. Garashchenko made contact.

"I have arrived in the zone," he reported. "Request permission to conduct the operation."

The officer gave him an "ok" and turned to me:

The battle will be interesting. Garashchenko's rival is young, but is also smart and persistent."

Meanwhile, the air situation was taking a normal course. In accordance with the mission, Lieutenant V. Kudinov attacked first. Garashchenko had to accomplish six piloting maneuvers, while Kudinov had to attack the flight commander six times.

The major energetically banked his aircraft to the left. The young pilot did not fall back. A thought flashed in Garashchenko's mind: The lieutenant is acting no worse than experienced pilots. When Kudinov ended the battle, the pilots changed roles. Now, the flight commander had to attack his subordinate. . . .

When I first met the collective commanded by Major Garashchenko, I at once felt an atmosphere of elation, creativity, and the drive everyone had to increase their successes in socialist competition. It is not only by chance that the aviators are confidently carrying out their responsibilities, persistently training the students to have high moral-political and combat qualities, and contribute a substantive input towards improving the quality of combat training. For the third year in a row the squadron has had a solid hold on its outstanding rating, and it is considered to be one of the most advanced subunits of the Chernigov Higher Military Aviation School imeni Lenin Komsomol.

It fell to my lot to attend a meeting where the communists of the squadron discussed how to fulfill socialist responsibilities. The discussion was sound and business-like. Garashchenko asked to speak, and immediately began telling what is preventing the collective from going ahead. Other communists supported Aleksandr Nikolayevich. The decisions of the party meeting were concrete and objective. . . .

The fate of people evolves in different ways. Some seek their place in life for a long time; others immediately make an error-free choice and remain faithful to it to the end. Difficulties do not scare people like that.

After having finished the ten-year school, Aleksandr Garashchenko dedicated himself to the flying profession. He became a pilot-instructor and himself began to teach youths. With time, he finished a higher school through correspondence. Persistently, as if climbing steep steps, he went toward his cherished goal. At the same time, he was able to save his youthful freshness and a spontaneous acceptance of life. "My biography is most normal. Difficulties? I did not hide from them," said Aleksandr Nikolayevich to me.

Later, the secretary of the unit party committee added:

"Do you know why else Garashchenko wins over all? With his tactfulness toward people, goal-directedness, and reliability on the job. If he promised, he will do it without fail. In addition, he has an enviable attitude of being cold-blooded toward everything. That is exactly how a pilot-instructor should be.

. . . They remember a certain incident in the squadron very well. Flights were taking place. Major Garashchenko entered the zone to work out some piloting techniques. When the aircraft flew through the cloud cover and attained an altitude of 3000 meters, he suddenly, subconsciously, got the feeling that something was wrong. He threw a quick glance at the instrument panel. The engine RPM indicator was nervously wavering. He immediately reported it to

ground control. He eased up on the engine control throttle. The revolutions of the engine became stable. He landed at full speed. He lowered his landing gear and flaps. He landed safely.

Aleksandr Nikolayevich told about this incident as if nothing had happened. But, after all, a landing in a "low gas" mode is a complicated matter. An exact computation is needed to be able to align yourself with the runway and hold to the glide path. . . .

Being demanding of oneself and having the persistence and single-mindedness with which an officer polishes his professional skills are qualities that are valued in the collective. There is also a high opinion in the squadron regarding Garashchenko's pedagogical abilities. He knows how to educate and train subordinates and is able to find, as they say, the hidden key to the hearts of fighting men.

The flight was augmented by the arrival of students of the first class. They got to be first to sit in the cockpit of a training aircraft. The experienced commander caught a barely perceptible constrained manner in a student, A. Lukshan, a smart-looking, well-proportioned young man. And he was not mistaken. From the very first flights Lukshan began to allow many errors: either the accelerated and vertical speeds were uneven, or he did not hold to the prescribed course. But, Aleksandr Nikolayevich did not hurry with his conclusions. He knew: students' rates of progression differ. Some follow the program easily; for others, more time is needed to master the ABCs of flying proficiency.

Time passed, but the desired changes were not observed in Aleksandr Lukshin's training. All students had already long ago gone over to solo flights, but he kept collecting demerits. At certain moments it seemed to Aleksandr Nikolayevich that Lukshan is hopeless and should be taken off the flying roster. But he immediately discarded these thoughts: "Apparently, not everything has been done yet."

In operational flying there are sometimes cases when the reasons for an aviator's failures are hidden in his lack of confidence in himself and his inability to find his weakness, which put a brake on forward progress. It was precisely this weakness that Garashchenko was looking for. The officer patiently taught Lukshan himself on the aircraft and with the "unmounted flying" method, used the ground trainer. And although he saw with what envy his student looked at his comrades who were flying by themselves, Garashchenko was in no hurry to let him go up into the sky. And there were weighty arguments for doing this. During the last flights, the instructor was not able to help his student overcome tension. Garashchenko's intuition told him that the solution was right there somewhere. He simply had overlooked something, didn't understand

something in the behavior of his charge, and for this reason had not uncovered the reason for his landing errors.

One time, the flight commander was working with Lukshan in the cockpit of an aircraft that was fixed on hoisting blocks. They were working on landings (for the umpteenth time!). The position of the aircraft corresponded to level flight. Suddenly, it seemed to the major that Lukshan's eyes were directed somewhere other than where they should be. But the way his head was turned, and the position of his body in the seat all seemed to be right, but it was his gaze that was somehow darting and searching. . . .

"Show me what point you're looking at," Garashchenko asked quickly.

The student showed him. The major jumped to the ground and stepped back a certain distance.

"And now, sit more freely, without being tense. That's it! Remember, he said, "you have to look here. And also remember your position. This is not unimportant."

During the course of Lukshan's training, Aleksandr Nikolayevich had found out a lot about him. Gradually, he was able to instill the qualities in the student that he had been lacking: diligence, persistence, and self-confidence. And it was crowned with success.

"Thank you, comrade major," said Lukshan one day to Garashchenko. I can't even believe that I'm already flying solo. And my evaluations are not worse than those of the others."

The commander also devoted unstinting attention to young instructors. Lieutenants confidently polish their professional skills and tenaciously master the subjects of pedagogy and psychology. Garashchenko teaches them not only how to improve their piloting and tactical mastery, but also how to work with students, and how to strengthen organization and discipline.

People come to communist Garashchenko. Some, to enrich their professional and life experience; others, simply to receive useful advice. It is no wonder that the aviators of the squadron have elected Garashchenko the second year in a row as the secretary of a primary party organization.

When I first arrived in the squadron, preliminary preparation for flying was being conducted. Major Garashchenko and Lieutenant Kudinov were preparing to complete a complex, but interesting exercise--an air battle. The officers thoroughly discussed every detail. And the next day was that very same battle with which I began this story.

After landing, the air warriors impatiently awaited the results of the data being decoded by the target control facility. Soon they were told: The battle was a draw. And this news made Aleksandr Nikolayevich's soul feel lighter: It meant that the combat augmenters were growing and maturing and acquiring durable wings.

COPYRIGHT: "Aviatsiya i kosmonavtika", 1982

11350

CSO: 9144/0605

AIR FORCES

HELICOPTER TRAINING: FLIGHT ENGINEERS DISCUSSED

Moscow AVIATSIYA I KOSMONAVTIKA in Russian No 1, 1982 (signed to press 2 Dec 81) pp 14-15

/Article by Major of Technical Services, V. Fadeyev: "Flight Technician"/

/Text/ A helicopter appeared over the dark edge of the forest. Several minutes pass, and it hovers over the designated, snow-covered pad and, lifting up white whirls, it lands smoothly. The flying mission was successfully completed, all systems and equipment of the propeller-winged aircraft functioned smoothly. Captain A. Zhakota of Technical Services and his subordinates are happy.

Officer Zhakota is one of the best flight specialists in the squadron and a leader of socialist competition in the new academic year. On board his aircraft is displayed an "Outstanding Helicopter" badge. There has not been a case when the aircrew has been delayed in taking off or when something went wrong in the air through the fault of specialists. The experience of the leading flight technician is well known in the subunit.

The officer has taken as his rule: Begin the working day with an exact understanding of the task to be done. Together with the chief of the flight's technical maintenance unit (TECH), Senior Lieutenant of Technical Services G. Fedorov and other leaders of the Air Force Engineer Service (IAS) squadron, he discusses how best to complete the most labor-intensive operations on the helicopter and how to utilize specialists more effectively. He will, without fail, pinpoint the instruments and control-testing apparatus that will be needed, as well as the amount of expendible materials.

The officer also instills a high degree of technical expertise in his subordinates--senior aviator mechanic Warrant Officer N. Zharov and helicopter aviation mechanic enlisted man V. Gulyayev. He reminds them of the need to adhere strictly to all rules of the aviation technical service in the winter time--during a complex and crucial time of year. Junior specialists, directed by Zhakota are diligently preparing a parking space so it can be used,

clearing snow and ice from it in a timely fashion. After all, maintaining a place of work in first-class condition is very important and has an influence, not only on work effectiveness of IAS personnel, but also prevents accidents to specialists and having a technician be incapacitated. During winter, it is necessary to open a larger number of operational and technological hatches in order to check the condition of junctions and to air out far corners where moisture can accumulate. The crew always has something ready with which to protect combat equipment from snowfalls.

Officer Zhakota also constantly takes care of maintaining ground equipment. The anticipation of the flight technician warrants noting. And here's why. Sometimes one sees how specialists accomplish all technological operations on a helicopter in a concentrated and knowing manner and, having finished their work, begin to walk aimlessly around the parking stand and waste time. Zhakota does not have this. In case flights are cancelled he always anticipates some other kind of work: control over doing technical documentation, testing the specialists' knowledge, putting ground equipment into tip-top shape, and so on. On his direction the mechanics sharpen the supports for the ladders and wheel chocks, repaint and relubricate, renew the erased stenciled signs on the hoists, and if necessary, fix the covers. He schedules all ground equipment in such a way, so as not to be in the way of maneuvering special automobiles and so as not to create inconveniences for transporting goods on the parking area.

No matter how limited the time, Captain of the Technical Service Zhakota will not permit a specialist from the operational group to work on a helicopter assigned to his care until he is convinced that the person knows his business, has the necessary instrument and has taken all precautions to preclude its falling into the engine or the control system. One time the flight technician kept away a mechanic who had tried to do a job in the helicopter cockpit while wearing dirty shoes. Another time, noticing dirt and small pebbles in the tire treads of a mobile airfield electro-assembly unit (the driver had independently changed his route across the airfield), he explained to the serviceman why it was dangerous to have them fall on the concrete roof of the airdrome and into the helicopter, and demanded that he not allow such infractions.

Zhakota also carefully looked after the course of repair work on his own aircraft in the TECh regiment. It is not that he does not trust the group specialists, but because he considers that additional control will not harm the quality of work. The officer thoroughly learned repair technology and especially service work during winter time training and strictly watches over its exact accomplishment.

One time Captain of Technical Services Zhakota, observing the

actions of mechanics in loading hydraulic accumulators, noticed that the specialists aren't doing everything as they should be. They filled the cavities with a reacting liquid, created the necessary nitrogen pressure, but curtailed the temporary range in measuring the pressure. Apparently, the mechanics did not take into consideration the phenomenon of diffusion of materials. With time, because of this pressure, much will change. The flight technician helped to correct the error. And when the helicopter took its place on the squadron pad, the technician, together with Warrant Officer N. Zharov and Enlisted Man V. Gulyayev, once more measured the pressure in the accumulators and in the chassis struts. He explained to his subordinates: In the TECH of the regiment the aircraft was in a "dry" condition, with partly filled fuel tanks and without a corresponding load in the cabin. Consequently, the load on the ground organs was one, and now it is different, and this must be taken into consideration.

Such an attitude towards the contents of technology, attention to the learning of subordinates, a high demand, and a constant caring about them brings good results. An attitude of mutual respect and carefulness reigns in the technical crew. Thanks to a healthy psychological micro-climate, the mechanics and the technician successfully cope with their responsibilities. All of them are outstanding in combat and political training, and specialists of a high class. They can accomplish a number of complex operations on the same level as can the flight technician.

One time, examining the system's heating pipes, Warrant Officer N. Zharov discovered sweating pipes. Reporting about this to Captain of Technical Service Zhakota, the senior aviation mechanic carefully looked over the condition of the nearby areas, analyzed the physical processes which flowed through the automatic fuel system. Having determined what was wrong, he took the necessary measures.

The present academic year is progressing under the motto of meeting the sixty-year anniversary of the founding of the USSR in a worthy manner. The outstanding technical crew decided to commemorate this famous date with new successes in military training and service.

COPYRIGHT: "Aviatsiya i kosmonavtika", 1982

11350

CSO: 9144/0605

AIR FORCES

FLIGHT TRAINING: USE OF RSBN-6S NAVIGATIONAL DEVICE DISCUSSED

Moscow AVIATSIYA I KOSMONAVTIKA in Russian No 1, 1982 (signed to press 2 Dec 81) pp 22-23

/Article by Lieutenant Colonel V. Polonskiy, Military Pilot First Class: ". . . Plus Navigational Training"/

/Text/ Captain S. Petrachenko's crew had to fly along a given route and land at another airfield. To advice given him by senior comrades: learn the RSBN system and carefully prepare for the mission, the pilot unembarrassedly answered:

"And what for? Everything is clear without all that. The flight is in a zone with visible radio towers to correct the position of the aircraft and the routes have been flown over many times, so everything will be in order. . . ."

Petrachenko also did not study the auxiliary route the way he should have, figuring that he knew it well. But this route was distinguished by sharp breaks and in one place had a zone of unstable RTS operations.

During the preliminary training the pilot passed the readiness control which, incidentally, was conducted very superficially, and received permission to accomplish his mission. During the pre-flight briefing a correction was made: the flight would take place along the auxiliary route.

At first everything went well. But, suddenly the little instrument panel light that showed the correction from ground RSBN beacons went out. Petrachenko was unable to determine the aircraft position with the aid of duplicate radio-technical and course systems. How is it that one would not remember a proverb here: It will rip where it is thin. Only the officers from the flight control group were able to extricate him.

But here was Senior Lieutenant N. Kulyukin flying above the clouds; having found himself in a similar situation, he did not panic. He acted coolly and calmly, knowingly used duplicate means of navigation, and successfully completed the flight. Recently, this pilot passed

the examination for first class.

The importance of navigational training of flying personnel is confirmed by practice. In the article, "On a Combat Course" (Aviatsiya i Kosmonavtika, 1981, No. 7), the honored military navigator of the USSR, General-Major of Aviation A. Shabunin, turns his attention to this matter. He justly notes that without navigation there is no aviation. The article was discussed in our unit, and many of its recommendations were taken for inclusion in training-educational work. At the same time, practice has shown that if in the "pilot-aircraft-control group" system one of the elements does not fully respond to requirements of high reliability, then--as a whole--the probability of successfully completing the mission decreases and the threat against flight safety arises.

A well-trained crew, having a thorough knowledge of the basic theories of aircraft flight and solid skills in using pilot-navigational systems and radio-technical equipment, as a rule, accomplishes assigned tasks only with outstanding results. However, the equipping of aircraft with modern apparatuses sometimes leads to an under-evaluation of aircraft piloting means that are old, tested by experience, and very simple: calculating a route by time (with a second-hand or mentally), depending on air speed; using a ground direction-finder and pinpointing aircraft location on the course and bearing indicator basis, especially for one-seater aircraft; and finally, determining the course by taking bearings on celestial bodies (sun, moon, stars). This is all the more important because modern navigational equipment does not exclude, but--just the opposite--assumes the necessity for constantly improving the traditional methods of air navigation.

Pilots and navigators receive good theoretical knowledge and solid skills in school. But if one does not systematically renew and maintain them at a necessary level, then with time they diminish. Technology, however, continuously develops and improves. This requires that pilots and navigators constantly work on strengthening the knowledge they already have. Otherwise, the resolution of complex tasks becomes simply impossible.

Let us say that the flight is for a maximum distance, a shuttle of aviation materiel for repairs or after the flight there is a number of circumstances which pilots sometimes underestimate. What do they consist of? In shuttles of small groups and individual aircraft, flying personnel are isolated from their units and control over their adherence to the pre-flight plan is weakened. A shuttle flight from one airfield to another takes place at high altitudes, as a rule, with suspended fuel tanks and often above the clouds, which requires from aircrew members good training and the knowledge to be able to use complex radio-navigational equipment, as well as all-round security measures. Sometimes a landing at an unfamiliar airfield

takes place with a minimum amount of fuel left, and this means that the aircraft has to be landed on the first approach. One also cannot disregard the fact that the flight control group and the shuttle crews do not know each other which, in turn, creates well-known difficulties. Also, training for shuttle flights is longer and more detailed than for an ordinary flight, since one has to carefully work out and study the necessary documentation.

The modern one-place aircraft is equipped with a perfect navigational system which--when used knowledgeably--allows the accomplishment of missions at the maximum tactical radius. This requires that commanders-educators strive to have every pilot and navigator know how to use it as a whole.

The leadership of our unit requires that the pilot in controlling the readiness of his aircraft, not only examine it, but specifically check the qualitative readiness of each system and each component. And this is explainable. Inattentiveness to how the take-off airfield matches the showing on the BVN can result in a deviation of up to 20 kms. over a straight flying route of 400-600 kms. And this is already a violation of the flight plan. Incidentally, an example of careless course plotting is given in the article, "On a Combat Course." Our pilots also incur errors in working with navigational equipment. This means that shortcomings in navigational training should be spoken about loudly, and not so much for chiding, as for preventing operational errors.

In the guidance system of third generation aircraft, a device has been provided that gives the initial course direction. For this, it is necessary to precisely calculate, while on the ground, the optodromic take-off course (OKV) and check before take-off if the course indicator is correct. Before take-off, the pilot positions the aircraft exactly on an axis, and nevertheless, an error in course direction occurs with approximately a plus-minus of two angle minutes.

In flying a route on a maximum distance, the RSBN-6S system allows any ground beacon that is overflown to be picked up. It is necessary, while still on the ground, to calculate the lateral deviation and the azimuth in flying through the traverse. In the cockpit one should, beforehand, manually find the frequency of the given beacon, and when approaching the given point of correction, press the "Drop" and "Return" buttons on the RSBN panel. The capabilities of modern navigational systems are great. Their full utilization will guarantee a high-quality accomplishment of flying assignments. One need only to learn them thoroughly and look for alternative methods.

As I already said, in shuttles of one-seater aircraft with landings on other airfields, their reception and control over adherence to

the flight plan are the concern of different groups of directing and controlling officers, whose own level of training in many ways influences the quality of accomplishment of the flying mission. In their training and education, the main role belongs to commanders and chiefs who have control over shuttle flights. However, it will happen that they don't always give themselves shuttle missions. And if during this period there are no flights at the airfield, then testing and control are sometimes entrusted to insufficiently trained combat control officers.

That's what happened during Captain Petrachenko's flight. When he asked the airfield CP the distance to the route turning point, Senior Lieutenant A. Nikolayev gave the crew distorted information. It turned out that the officer in combat control did not clarify the shuttle mission well enough, and besides this, the names of the points were similar. The extra intervention and aid of the flight director prevented a further mix-up, and the flight ended safely.

Or, another example. In overflying the beam of the airfield, an aircraft group headed by Major A. Ivanin, as a result of a strong sidewind, deviated from their flight path by 10 kms. Instead of the command, "Turn right five degrees," Lieutenant Stepanov, an officer of combat control, not clearly comprehending the optodromic flight path, gave the order: "Take a 270-degree course." But before giving such an order, he should have asked what the flight course was.

Unfortunately, similar incidents are not isolated. The reason, in my opinion, lies precisely in the fact that some flight directors do not fully comprehend the importance and criticality of the mission being flown by individual crews and small groups.

It is entirely possible that some stated conclusions and situations are debatable, however, the reality of issues regarding navigational training of flying personnel, and the groups directing and controlling flights, are indisputable. I think that the readers will actively respond to the discussion begun in this journal and will express their points of view.

I would like to propose as a subject for discussion, a modification for an approved chart for one-seater aircraft that is equipped with a radio-technical system of short-distance navigation.

In accordance with documents regulating shuttle flights, it is recommended to use a pasteboard, large-scale chart on which no more than two flight routes can be plotted for any one shuttle.

After the pilot has received a shuttle mission, takes the sheet and pastes up the chart, he is faced with a question: How can it be quickly, correctly, and knowledgeably annotated; what, and in what sequence should it be entered on the chart? The difficulty consists of the fact that if everything is entered that is required by

documents, it is difficult to conduct an orientation according to such a map. On the other hand, if one enters the limits of control transmissions prior to entering auxiliary airfields, then there will be an overlap, since the limits are strictly tied to the one place. In this situation it is desirable to note an operational sequence that would permit a quick accomplishment of necessary work, and annotate the chart in accordance with document requirements, so that during the flight it would be easier to work with it.

Experience has shown that before annotating the chart, one should calculate the RSBW program in advance, complete the engineering-navigational calculations and jot down in a working notebook the radio-technical equipment of auxiliary airfields. Having made the calculations, prepare the chart, i.e., highlight the characteristic linear and area orientation points with colored pencils: red--borders; yellow--border forbidden zone. Then, with an ordinary soft pencil, enter the axis and flight route (2.5 cm. to the side of the axis).

With red circles of 10-15 mm. in diameter, mark the turning points along the flight route. All other notes, or most of them, should be made beyond the flight path line. To the right of airfields, designate their magnetic inclination (in a blue circle with red color). Along the flight route, highlight high elevations with a black color, and with red, emphasize the marginal bearings from the country's borders. With a solid red line, enter the area of responsibility of the UVD along the flight path. With green (everything that relates to the RSBW), fill out the coordinate net every 10 cm., and designate the beginning and the axis of the coordinate optodromic system.

At the beginning of each stage, and every 10-15 cms., enter computed data for the flight path (distance and time in black; optodromic route angles in blue). In accordance with the shuttle flight plan, designate the basic and auxiliary airfields, orientating the landing direction and the position of the airfields relative to a populated point. On the airfield designation, enter the direction of the approach for landing in the SMU and the flight circle in the PMU. Within a blue oval, and in blue pencil, highlight the computed amounts of fuel left next to control orientation points, and assembly, decreasing altitude, and return areas. To the left of turning points, mark in black, the tuning knobs of the RSBW and ARK, and to the right--the azimuths and distances (calculated beforehand) to ground beacons for flight route corrections.

On the right side of the LZP, calculate and enter, in black color, 5-minute segments, and to the left--in green--calculate the distances every 50-100 kms. to the PPM. In red, next to the usual linear orientator, highlight the test limit for the course systems (RPKS). In blue, note the sequence in which signal lamps show fuel

consumption with an indication of the amount of fuel left and the tank number. Along the flight route, designate the areas where civilian air routes cross, the areas of control transmissions and call signs, the assembly, altitude decrease, and return areas. In a green rectangle, 3x5 cm., at one side of the flight route, note the RTS of auxiliary airfields, landing directions, magnetic inclinations, and designate them with arrows. After entering the calculated data, fold the map, so that it will be easy to work with in the air.

For all these operations, every pilot can prepare a template similar to an officer's ruler.

Experience in organizing the training and the accomplishment of route flights and shuttles has demonstrated that there are alternative means for raising the quality of flight mission accomplishment. They need only be found and creatively applied in flight operations.

COPYRIGHT: "Aviatsiya i kosmonavtika", 1982

11350

CSO: 9144/0605

AIR FORCES

FLIGHT TRAINING: EMERGENCY, GEAR-UP LANDINGS DISCUSSED

Moscow AVIATSIYA I KOSMONAVTIKA in Russian No 1, 1982 (signed to press 2 Dec 81) pp 26-27

/Article by Major A. Berezin, Military Pilot First Class: "Landing . . . With a Retracted Landing Gear"/

/Text In the performance of my official duties I often work on calculating and analyzing various pilot errors and systematically work with documentation where these errors are recorded. One fact that is striking is that certain proclivities for air incidents occurred through the fault of those who have been piloting supersonic fighters for at least a year or longer. One can somehow make an explanation for goofs committed by young airmen: now and then they don't have enough experience. But what is the reason for errors by rather experienced pilots?

. . . Flights were being conducted. In accordance with the scheduling board, the fighters came in for landings after having completed their missions. From the ground it was noticed that one of them was gliding with landing gear retracted. The flight director immediately sent the aircraft around to make a second circle. It is not difficult to imagine what tough consequences could have resulted because of the pilot's negligence if the error had not been caught in time.

And the rocket-carrier had been piloted by Major V. Prusakov, an experienced pilot. When they began to look into the reason for the near-error, he threw open his arms and announced: "I forgot to lower the landing gear." Such forgetfulness, of course, does not suit a high-class specialist. I am firmly convinced that the pilot's forgetfulness in this case was not the only reason.

The night before the flights the commander had told of an analogous incident involving a young pilot. He had required that everyone scheduled to fly had to spend time in a ground trainer and go through a supplemental routine in fighter cockpits relative to retracting and lowering the landing gear. Major Prusakov had reacted cavalierly to this order. But the sky, as is known, punishes those who deviate from the rules for flight training, and the experienced aviator turned out to be at fault for a serious prelude to an air incident.

There is an immutable law in aviation: To thoroughly prepare for each flying assignment no matter how complex or repetitive. Life itself inspires this rule. And nothing can serve as a justification for deviating from this truth. I remember how we were preparing for firing exercises, using "air-to-air" rockets against air targets. The exercises were to be run for both experienced and young pilots. Lieutenants, as usual, diligently learned the relative theoretical situation, and with a special zeal worked on how to operate apparatus and switches of the armament system. Each tried, if possible, to get into the ground trainer one more time.

But, here you had some worldly-wise air warriors who, unfortunately, did not show such diligence. Some of them relied on their old bag of knowledge, assuming that they would be capable of confidently coping with the assigned mission. It is a pity that this was discovered not during training, but later during practice take-offs, when nothing could be corrected any longer. Self-confidence, as was to be expected, let them down in a big way.

When the flights began, the youths showed themselves well. But here was an officer who held a military pilot-sniper rating, and he was not at altitude. At first, it seemed everything was going normally. Entering the designated zone, he sighted the air target and began the attack. The small signal lamp lit up, allowing the rockets to be fired. But there was no fire: in the most decisive moment of the battle with the "enemy," the pilot permitted an error in operating the armature in the cockpit, and valuable seconds were lost. Neglecting the ground training turned into a low evaluation for the aviator. He embarrassed not only himself, but the combat collective.

But, after all, both Major Prusakov and the pilot-sniper who allowed the serious error in the firing zone, themselves had trained pilots. They pay lip service to support ground training completely and persistently call others to strive achieve the highest scores. But they themselves do not follow these ideas in practice. Their errors throw a shadow over their authority, reflect negatively on the training of able air warriors, and undercut the moral right of instructors to require from their students exemplary completion of flying assignments. One should not forget this; one's words should be reinforced with good deeds and a timely adherence to the requirements of directive documents.

As is known, a guarantee of success in the air is excellent training on the ground. Its most important component is the systematic, goal-directed training on special apparatus and in aircraft cockpits. The commander-instructor is duty-bound, above all else, to display the proper example toward this training.

At one time I served under the leadership of squadron commander,

Major Yu. Shvarev. He had a most rich experience in flying under various meteorological conditions and in complex tactical situations. I don't remember a case when this squadron commander, for any reason, would not go to a ground trainer prior to flights, or miss the smallest opportunity to work with cockpit equipment. We line pilots strove to imitate him in this.

And now, the leading aviation commanders approach ground training just as responsibly, not only for their subordinates, but for themselves. Military pilot first class, Major V. Alabushev, has a precise, well-thought-out plan for such training. Moreover, each time he makes it up with a view toward the future. During a time well ahead of the training period, he persistently improves the skills that he will need in completing future flights, especially in new and more complex exercises. And during preliminary and pre-flight training, he diligently hones and polishes his skills. Naturally, he precedes practical studies every time with study or repetition of corresponding theoretical problems. In sum, in completing his assignments, the pilot always scores high in knowledge and mastery of all weapons.

I remember a certain incident. A fast air target was flying at low altitude. Major Alabushev was ordered to intercept it. The "enemy" was experienced and energetically performed maneuvers. But he still could not break through to the defended target. Alabushev attacked and "destroyed" him on the designated boundary.

Of course, to a great extent, success depended on reliable guidance from the command point. But the real merit in winning that important and difficult duel belonged to officer Alabushev, who, in the course of independent training for interception, especially in a ground trainer, worked out a space-time model for his operations, guaranteeing himself an irrefutable first strike at the "enemy." This model included both a precise sequence of operations at different stages of the flight and limitations as to speed and overload factor, as well as strengths and weaknesses of the opposing aircrew.

Major Alabushev also attains methodically informed and quick operations with interceptor cockpit instruments from his subordinates on the flying staff. He constantly strives to see to it that not a single error remains undetected and he thoroughly analyzes miscalculations. Often, shortcomings are eliminated by special training.

One time, one of the young aviators incorrectly warmed up and tested his engines prior to taxiing from the stand. The commander thoroughly examined his operations. Taking into consideration the fact that others might commit the same error, he organized a special training session. At the beginning the deputy commander for the engineering-aviation service told about the physical nature of warming up and testing engines. Then, Major Alabushev showed the correct way to conduct this operation. Finally, the pilots

completed this operation by themselves. In addition, a seminar was conducted in the collective, in which problems of engine-starting and testing were discussed. This resulted in a definite benefit. In the future, the young officers did not allow any errors.

At times, Major Alabushev is also rather strong-willed. He systematically, after a certain period of time, repeats operational functions when certain cases arise during flights, so that he won't be caught unaware if the air situation suddenly becomes more complex. Under Alabushev's leadership, even his subordinate pilots work out operations under extreme conditions, and this training is combined with their education in attaining high moral-psychological qualities.

Unfortunately, one has to admit that not all pilots of the headquarters staff have the same attitude toward ground training. Some depend at times on their solid experience. Others, when time approaches to go either to the hard-stand or to class, where special equipment is installed, use the excuse of being occupied with various duties, and try to avoid ground training in every way. This is too bad. They are not considering the fact that life may seriously punish them in the most inappropriate moment. One should always remember the golden rule: Good ground training is the basis for high quality flight training and flight safety.

COPYRIGHT: "Aviatsiya i kosmonavtika", 1982

11350

CSO: 9144/0605

## AIR FORCES

### FLIGHT TRAINING: SIMULATOR FOR AERIAL COMBAT DISCUSSED

Moscow AVIATSIYA I KOSMONAVTIKA in Russian No 1, 1982 (signed to press 2 Dec 81) p-29

Article by Guard Captain S. Gribanov: "'Projector-Target' Apparatus"

Text Air gunners who became aircrew members of bombers and assault aircraft during the years of the Great Fatherland War reliably defended their aircraft from attack by enemy fighters. Not rarely dog-fights ended very badly for the fascist pilots.

Victory in air battles depends greatly on good training: a solid knowledge of one's own weapons, the ability to correctly determine the distance to the target and its aspect, and to be able to aim precisely and open fire in a timely manner. To a great degree this is facilitated by continuous classes on the ground and through training.

Based on combat experience for educating and training air gunners, our unit uses an apparatus called "Projector-Target" made by our rationalizers, that operates in conjunction with the SKT gunnery training apparatus. It facilitates working out skills in aiming, framing, and determining the distance to an air target during exercises on a trainer equipped with optical aircraft gun sights.

The principle of operation of this apparatus is based on projecting a light source onto an opaque screen through a movable contour of an aircraft silhouette (Fig. 1).

By changing the position of the cut-out contour in relation to the light source, the size of the silhouette target will change in accordance to the following law:

$$L = p \frac{h}{f}, \text{ where}$$

L = size of light silhouette on screen;  
p = size of the cut-out contour;  
h = distance between the contour and screen  
(height of the projector);  
f = focal length of the projector.

This apparatus gives the gunner who is aiming, the illusion of the target moving closer or farther away.

When used in conjunction with the SKT, this apparatus permits changes to be made automatically in the size of the silhouette on the screen simultaneously with a change in the angle position, and makes air battle attacks easy to follow.

The light silhouette changes its size automatically, as a function of moving an SKT arm into horizontal or vertical planes, relative to the immovable base. The "Projector-Target" is installed at the end of the arm and, with the aid of a control-rod, is connected to the immovable SKT base (Fig. 2). When the arm changes its angle, the control-rod is stretched and, through an inverse apparatus, changes the contour of the aircraft--the target silhouette grows larger on the screen. The further the arm goes, the more the control-rod is stretched, and the larger the silhouette--and the aircraft attacks.

The apparatus is brought back to its initial position by returning the arm to neutral through use of a reverse spring mechanism (when the distance to the target is maximum, the size of the silhouette is minimum). The simultaneous changes of the position of the SKT arm in horizontal and vertical planes leads to a quicker change in the projection of the light silhouette on the screen.

The effectiveness and easy-to-follow training of air gunners with the aid of this apparatus through the use of optical, especially semi-automatic, sights is very high. This has been confirmed by the quality of completed gunnery practice.

Figure 1 (a) and 1 (b)

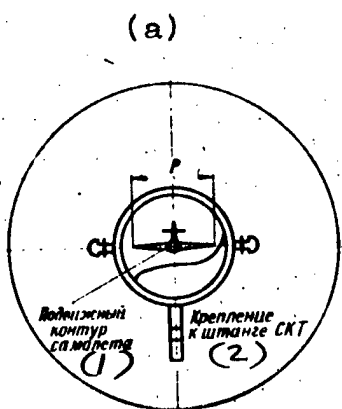

Rear View

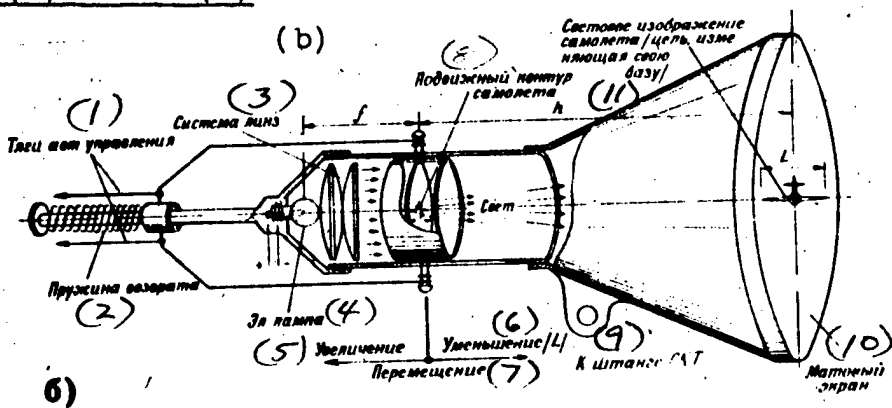

View from Above

- a)
- |                                   |   |
|-----------------------------------|---|
| (1) Movable aircraft contour      | (9) Connection to SKT rod   |
| (2) Connection to SKT Control-Rod | (10) Opaque screen  |
|                                   | (11) Light image of aircraft/target changes its size and position |
- (1) Tension for Auto. control  
 (2) Return spring  
 (3) Lens system  
 (4) Light bulb  
 (5) Increase  
 (6) Decrease  
 (7) Movable focus  
 (8) Movable aircraft contour

Figure 2: Mounting the Apparatus on a Firing Trainer

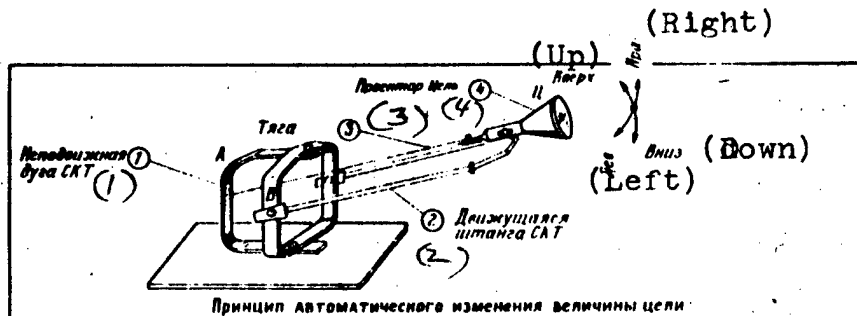

Principle Behind the Automatic Change in Target Size

- (1) Immovable yoke of SKT
- (2) Movable control-arm of SKT
- (3) Tension
- (4) Target projector

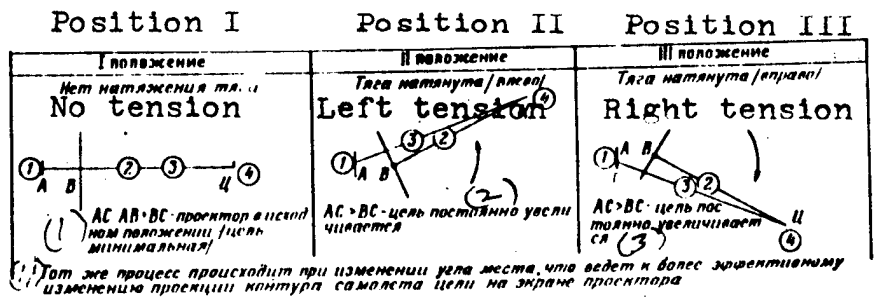

- (1) AC AB·BC - The projector is in its initial position. The target is minimal size.
- (2) AC > BC - The target gradually increases in size.
- (3) AC > BC - The target gradually increases in size.
- (4) The same process takes place in changing the position angle, which leads to a more effective change in projecting the change in the aircraft contour target on the projector screen.

COPYRIGHT: "Aviatsiya i kosmonavtika", 1982

11350

CSO: 9144/0605

AIR FORCES

COMBAT TRAINING: ROLE OF "ZAPAD-81" REPORTAGE DISCUSSED

Moscow AVIATSIYA I KOSMONAVTIKA in Russian No 1, 1982 (signed to press 2 Dec 81) pp 30-31

/Article by Colonel Yu. Belyayev: "Experience of the Leaders"/

/Text/ The army press plays an important role in mobilizing the personnel of aviation units and subunits to master combat technology and weapons and know how to apply and use them using their initiative. This problem is being resolved in a well-thought-out manner by the newspapers; VO SLAVU RODINY of the Red Banner Belorussian Military District and the ZA RODINU of the Red Banner Baltic Military District. This was especially clearly shown in the course of preparing for and carrying out Exercise "Zapad-81."

The contributors to the aviation sections of these newspapers did a great deal to embrace a broad range of problems relative to the combat and political training of pilots, engineers, technicians and mechanics, command post specialists, in the units and subunits concerned. Worthy of approval is the fact that during the designated period advanced experience in study and mastery of aviation technology was propagandized in an especially active manner. It was talked about by its own creators--the best commanders, chiefs, masters of training and education, highly qualified specialists, political workers, and party and Komsomol activists. Military correspondent-aviators were introduced in a proper way in a joint issue of the newspapers VO SLAVU RODINY and ZA RODINU, published prior to the exercise. Military Pilot First Class, Lieutenant Colonel V. Zubkov, from the Baltic area, led a discussion about the activities of a leading aircrew of a bomber aircraft, while Lieutenant Colonel N. Chizh, an officer of the air staff from the KBVO /Red Banner Belorussian Military District/ devoted his article "A Striking Start," to the achievements of pilot-sniper, communist, officer V. Vorob'yev. Without a doubt, these interesting presentations achieved their goals and played a positive role.

"Exercise 'Zapad-81' is a test of our readiness to defend our Fatherland;" "Air battle: Tactics, fire, psychology;" it was under these and other headlines that the newspaper ZA RODINU systematically printed materials during the preparation period. They were

distinguished by the variety of genres and forms of presentation. Among the most successful publications, one should first name the articles, "Mastery and the Power of the Spirit," by Major V. Osmanov; "People and Technology" by Master of the Guards, Captain of Technical Service V. Musikhin; and "Lessons of Mastery" by Guard Major A. Mikhaylov.

Officer Mikhaylov touches upon such an important aspect in the methodology of training essential to knowledgeable piloting and combat application of aircraft, as a flight debriefing. The author reinforces his own thoughts with concrete convincing facts from the life of a leading aviation squadron. He examines the work of flight commander, Guard Major V. Simonenko, sufficiently and thoroughly. This teacher of young pilots, while determining the results of interceptions of air targets, in addition to putting out a summary for combat application, also calculates--using the material from the objective control system--all the pluses and minuses of his subordinates' operations over the entire length of the mission, and always analyzes them in detail. The flight commander has a special notebook where he jots down even the tiniest shortcomings. Summing up and a thorough examination of errors give Simonenko the opportunity to find the right ways to raise the level of training of young pilots. The subunit which he leads is marching on the right flank of the competitors and its combat readiness is rising unwaveringly.

Good examples, witnessing the creative successes of workers in the aviation section, are also to be found in the newspaper, VO SLAVU RODINY. Under the headline, "Among the Troops Preparing for Study," the newspaper printed materials which helped the Air Force fighting men of the district to better understand the problems facing them, and to be imbued with a feeling of high personal responsibility for their exemplary resolution. The presentations of the military correspondents and their civilian colleagues on the editing staff of this newspaper were also distinguished by the differences in genres and in forms of publication.

Through examinations for a professional certificate, the ability to quickly and exactly catch the important points, and reflect this in the pages of a newspaper--logically, clearly, and constructively--became studies in themselves for the journalists. The dynamism of troop combat operations, quick changeovers in the tactical situation in battle areas, and time pressures presented high demands on those who were reporting the train of events. It should be noted that the test was successfully passed: Aviation themes were written about in every issue of the papers that came out during exercise "Zapad-81." The presentations of newspaper workers A. Kosov, "In the Sky are Cover Fighter Aircraft," and A. Drozolov, "Precise Pulse of an Airfield" (VO SLAVU RODINY), and M. Novikov, "High Incandescence"

and G. Karpenko, "A Winged Formation" (ZA RODINU), and other publications. They convincingly reveal the experiences of subunits during the exercise, as well as individual pilots, technicians, and aviation specialists, and justly underline the thought that the success of the right-flank military studies, the socialist competition for an exemplary solution to problems placed before the servicemen by the XXVI Congress of the CPSU, were all facilitated by a good mastery of combat technology and weaponry.

To the credit of those journalists who write on aviation themes, it should also be noted that while they were already in the midst of the exercise they managed to help non-civilian newspaper correspondents publish their articles. It is enough to cite only two facts. Substantive and full of interesting thoughts were the publications of "Group Flying" by Military Pilot First Class Captain A. Belyayev (VO SLAVU RODINY), and "The Basis of Outstanding Training" by Military Pilot First Class Captain G. Malyshev [ZA RODINU).

Exercise "Zapad-81" gave much that was new and valuable. And the comrades from the newspaper of the Red Banner Belorussian Military District acted absolutely correctly in publishing the headline "Zapad-81": "The experience of the exercise is armament." Let us take only one article published under this headline, "Combat Maneuvering of Helicopters." Military Pilot First Class Captain N. Gorshkov shares the thoughts about the coordination of ground and aviation subunits and their place and role in a contemporary general military battle. I think it is important to say that the newspaper VO SLAVU RODINY publishes regularly and plans well articles on problems of combat cooperation. On its pages, a column, "For Ground Forces--Aviation Support," has been solidly established. One also remembers, and interesting serious thoughts are provoked by the articles of Military Pilot Second Class Captain A. Bezhenutsa, "Repeat the Approach," Navigator of the Aviation Squadron Captain V. Arzhayev, "Motorized Riflemen Ask for Fire," and Military Pilot First Class Captain N. Kozhukh, "Helicopters Over the Battlefield," and others.

The workers of the aviation section of the newspaper, ZA RODINU, should write about this important aspect of air training more often. Unfortunately, one has to acknowledge that the further the date of completion of exercise "Zapad-81" passes, the rarer the newspaper turns to the experience gained by it. And it's too bad. After all, its use gives the military aviators the opportunity to resolve problems in a new academic year more qualitatively and effectively, and to achieve higher marks in socialist competition. The exercise greatly enriched the troops with advanced experience in utilization, and combat application of technology and weaponry of different types of aviation. And of course, one should not spare either effort or

time in order to make it the possession of the personal staff of the Air Force Red Banner Baltic Military District.

An analysis of works by the contributors to the aviation sections of the newspapers VO SLAVU RODINY and ZA RODINU gives the basis for concluding that they have many creative successes and findings to their credit. However, it would be incorrect to assume that the theme of mastering combat technology and weaponry is always illuminated the way it is required in today's world. It is noteworthy, for example, to pay strict attention to the education of flying, engineer-technical personnel, and other aviation specialists in the art of high discipline. One cannot say that newspapers do not write about this. But one would desire more concreteness, about fulfilling one's duty on combat watch or in filling out planning sheets for flight schedules, and so on.

The readers of the newspapers, ZA RODINU and VO SLAVU RODINY, would be grateful if they would find out about new forms and methods of party-political work conducted in the interest of increasing combat readiness and flight safety. A detailed examination of the utilization of aviation technology on the ground is required, as well as use of ground trainers, and the struggle for economy and savings. In order to have military aviators be aware of indefatigable vigilance, strive tirelessly to strengthen combat readiness, and improve combat capability, it would be very useful to have publications on technology and tactical operations of units and subunits of the armies of leading capitalist states, and first of all those which are in the aggressive NATO bloc.

". . . A person who has completely mastered technology," points out Comrade L. I. Brezhnev, General Secretary of the CC of the CPSU and Chairman of the Presidium of the Supreme Soviet of the USSR, "will remain the main and decisive force in war." In the new academic year, important and crucial problems on strengthening the defensive might of the Fatherland, in the light of requirements of the XXVI Congress of the CPSU, stand before the military aviators. To help them successfully fulfill these requirements is the duty and obligation of workers of aviation sections of newspapers published in military districts and groups of forces.

COPYRIGHT: "Aviatsiya i kosmonavtika", 1982

11350

CSO: 9144/0605

AIR FORCES

TECHNICAL SERVICES: HELICOPTER FLIGHT PREPARATIONS DISCUSSED

Moscow AVIATSIYA I KOSMONAVTIKA in Russian No 1, 1982 (signed to press 2 Dec 81) pp 32-33

/Article by Lieutenant Colonel G. Chaplygin: "Attitude Towards the Task Explains It"/

/Text/ It is rarely that anyone other than specialists of the engineering-aviation service arrives at the airbase earlier and parts with warplanes later. From their knowledge, mastery, love of work, and goodwill depend the successes of the flight staff, flight safety, and the reliability of technical work to a decisive degree.

I have met many wonderful engineers, technicians, and mechanics who were truly in love with their professions. For example, I will never forget our senior technical officer, V. Puzanov, with whom I once served in a detachment; good-natured, attentive, and especially sensitive towards young people. I remember a certain incident.

A group of specialists was ordered to prepare an aircraft for night flights. There was barely enough time. Some doubted that the mission could be prepared in time. It was at this time that Captain of Technical Service Puzanov came up to them.

"What's the matter, comrades? Is it difficult?", he asked and looked at this watch.

Then the officer fixed his glance on the mechanic, who could not get to the pipeline in order to disconnect it. The soldier was nervous, the wrench kept slipping from the nut, and he was getting abrasions on his hands.

"I see that it's hard," remarked the Captain. "But why get nervous? Technology does not forgive that. Here, let me have it and I'll try."

The officer took the wrench and deftly began to unscrew the nut.

"You see? When it's calmer, the matter goes a lot better." Puzanov disconnected the line and, handing the mechanic his instrument, gave him some advice: "You don't even need great strength here. At the same time you shouldn't waste it for nothing: And so today we'll have to work late."

In order to raise the morale of the young specialists he told them about an incident from his long-ago youth, a youth that was seared by the combat thunder.

"This was at the end of the war," began Captain of Technical Service Puzanov. "My commander flew out on a combat mission. And when he returned, the aircraft literally did not have a single area that was not riddled by bullets like a sieve. As they say, the pilot brought his aircraft home only by good luck: One engine had cut out while he had still been flying over the front line, and the second one quit on his approach to the airbase. After landing, the commander immediately hurried with his report to the command point. And we, mechanics, knew that with the dawn, the crew would have to be up in the air again. We readied the aircraft during the night, and made it by the deadline."

The officer's story turned out to be to the point. The work started going at full speed, and the specialists performed it better and in a friendlier manner. The aircraft took off on time.

. . . A low cloud cover hung over the airbase. The deputy squadron commander for IAS and I were walking along the hardstand. Now and again he would stop, ask the flight technicians how much and what they had completed, and reminded them about the uniqueness in testing various systems. We came up to two helicopters having the numbers "23" and "24."

"They are being serviced by the brothers Nikolayenko, who are warrant officers," said the engineer. "Vasilii and Grigoriy are flight technicians who have been flying many years and have a masters qualification. Each of them has flight time of over two thousand hours. Both of them are member of the Komsomol, love to work, try hard, really feel for their jobs, and always keep their aircraft combat-ready. The other day, the chief engineer of the school was checking Grigoriy's helicopter. He went away happy. Both Nikolayenkos are good teachers. In one word, our beacons. What is the secret of their success? Talk to them yourself."

I made the acquaintance of Warrant Officer Vasilii Nikolayenko.

"My brother and I are going through life together," he began. We finished the ten-year school on the same day, and later the agricultural school. At first we worked in a kolkhoz. Then in the army, and during our enlistment, we became flight technicians, and forever became welded with our souls to propeller aircraft,

flights, and aviation. Of course, at first it was a bit tough-going. Everything would seem to be clear in theory, but when it came to work, a helicopter job, difficulties arose. It is as if there was no system: First you do one thing, then another. But the volume of work was great and you'd miss something now and again. And at the same time, all the operations are precise and you need a high level of technological culture. It can't be otherwise. Flight safety demands that one notice everything on time and fix it: After all, you can't take care of a deficiency in the air. At first, we were given a lot of help by our older comrades, communists, and Komsomol members. Of course," continued the warrant officer with his story, "now it's easier: Experience saves us. But experience is experience, and skills, knowledge, and know-how constantly have to be improved, enlarged upon, and updated. And you have to keep a sharp eye out: You gradually become used to your own aircraft and that dulls, as it were, your eyesight. At first glance, it looks like everything is normal, but you look closer and more attentively and you see that here a cover is torn, there a nut has gotten loose. In a word, special attention is needed in our kind of work, an in-depth look, that is, you need a thoughtful examination and not a mechanical one. My brother and I like flight technician work. Why? It's difficult to answer this immediately," Vasilii smiled through his black whiskers. "I love to go up into the sky on my propeller craft. It's true, when you fly a lot in circles and in zones, you get a little tired of the same view. It is more interesting on route flights. But if I don't fly for one week or more, I am irrepressibly drawn to the sky."

I listened to the soft Ukrainian accent of Warrant Officer Nikolayenko and unwittingly thought: What is the secret of success of the leading specialists? The deputy commander for IAS later helped me find the answer: It lay in themselves, in their good-natured attitude toward their duty, their responsibilities, and their high demand, first of all, toward themselves.

"Individual work with students, and especially with first-year students," meanwhile continued Nikolayenko, "has first priority in our crew. They got their knowledge in the flight training section, but so far they have little experience. But I go up into the sky with them. I have to control their actions carefully, and remind them what to do in specific situations. The correct advice to a student and timely information to a pilot-instructor facilitates a quick development of future air warriors . . ."

The twin brothers, Warrant Officers Nikolayenko, picked the same aim in life: To serve conscientiously and to give all it takes, so that they could look squarely into the eyes of their comrades and the commander. And, after all, it is nice to be a leader.

A student, M. Putyatin, spoke warmly about Warrant Officer Grigoriy Nikolayenko:

"We came to the airbase with shyness in our hearts. The flight technician met us in a friendly way and sympathetically said: 'Don't be shy. If you want to, you will overcome everything.' Here we felt especially well what a friendly elbow of an older comrade is: In a difficult minute the flight technician will always support you and in a needed moment, he will remind you of what you forgot. With our own eyes we became convinced of the importance of a well-coordinated aircrew. On maintenance day, the warrant officer is always interested in our moods, encourages us, and gives us specific tasks. And he, himself, will help us at any moment, will show us, and give an instructive example from his experiences of flights with other students."

"One time I was looking over a hub of a propeller," continued the student. "It looked like everything was in order and in place. But, Warrant Officer Nikolayenko said: 'It looks like the cover on the hydrodamper is weak; you have to change it.' And immediately, here on the spot, he told us about the construction and importance of the hydrodamper and explained what could happen if it failed to work."

"Coordination and cooperation is the strength of an aircrew," said Sargeant Z. Genitulin, entering into the discussion. "Not everything turned out well for me at the beginning either. In my first solo flights into the zone, the rotor blade could not keep the revolutions at the required rate. It appeared that I was putting my attention in the wrong place. So, Warrant Officer Nikolayenko reminded me in time about this. And later, after the flight, he immediately helped me understand how an engine works. . . ."

What can one say? The job of a flight technician is difficult and responsible. But when they give the job everything they have, and share all their joys and failures with the collective, it is easier and more interesting to serve. In this flight, there are good words going around about Warrant Officer A. Leonov. He has been servicing aviation technology for nearly ten years and there has not been a single incident due to his fault. This flight technician also has the masters qualification and fulfills all his flight tasks with the highest possible quality job and keeps his helicopter in an outstanding condition. On maintenance days, communist Leonov strictly and individually determines what job each student will do and constantly teaches young aviators by using "live" apparatuses.

One time Cadet M. Kalinin did not submit a report on the rules of using aviation technology prior to a solo flight. Warrant Officer Leonov, not considering his personal time, worked with him on the helicopter until Kalinin passed the test. Cadets are drawn to Leonov. He can answer any question for them on the operation of the helicopter since he knows the machine down to the last little screw. The work experience of communist A. Leonov has been generalized more than one time in the flight.

Unfortunately, however, there are also persons who are negligent in this combat collective. For example, in the same squadron, only in a different flight, Warrant Officers V. Filimonov and Yu. Podsevakhin managed to get a number of reprimands in a short period of time. For that matter, their knowledge of aviation technology isn't so high. For a fifth year, Filimonov and Podsevakhin have not increased their class qualifications and have remained at the third class. Now where is there an example here for others? Because of them, the flight has been in last place for a long period of time, while the squadron has been ranked in the middle.

Of course, specific work was conducted with these warrant officers. They discussed things with them, punished them, morally influenced them, and temporarily transferred them to other duties. Meanwhile, Warrant Officers Filimonov and Podsevakhin are not exhibiting any special zeal towards their work.

People in every subunit are different, and that means that the approach to them also has to be special and individual. Every person has his own character and his own fate, but the interests of the flight and the squadron are common to all. There is one task here: So that there will be no place for those who are negligent and careless to be together with leaders in a combat collective. Then, successes in both studies and in socialist competition will become greater.

COPYRIGHT: "Aviatsiya i kosmonavtika," 1982

11350

CSO: 9144/0605

AIR FORCES

TECHNICAL SERVICES: INNOVATOR'S WORK DISCUSSED

Moscow AVIATSIYA I KOSMONAVTIKA in Russian No 1, 1982 (signed to press 2 Dec 81) pp 34-35

/Article by Engineer-Lieutenant Colonel A. Makarov: "An Inventor Submitted a Proposal"/

/Text/ The meeting of the okrug commission on inventions, chaired by Engineer-Major General N. Petrunin, dragged on. Experienced specialists examined in detail every proposal made by rationalizers. They selected the more valuable apparatuses, standing out because of the originality of both their construction and technological solution, as well as the simplicity of making the apparatus. It was planned to exhibit some of the works at a science-technology youth creativity fair regularly held at the VDNKh of the USSR.

The members of the commission paid a great deal of attention to the inventors from one of the aviation repair enterprises. Here, in comparison to last year, for some reason they submitted and introduced nearly sixty fewer inventors' proposals. Incidentally, a similar situation also developed in other aviation units which had earlier attained high marks in competing with other military collectives. Does this not testify to the decrease of creative thought? After all, the collectives, the laureates of the country's Main Fair, should be the leaders in every respect. The members of the commission understood, however, that the number of proposals, although important, was not the main indicator. Far more important are such indicators as economic effectiveness and how widely the invention proposal would be used. And some of the inventions from this enterprise were found to have a use in the national economy, a factor that enriched the state treasury by another several thousand rubles.

The decrease in the number of proposals was caused mainly by the fact that specialists began to approach the qualification of presented proposals more strictly. Members of the commission on inventions "rejected" second-rate projects and kept only the best.

Let us take, for example, the work of Yu. Chiras. He introduced

several new items into the technology of repair-restoration operations. The specialist constructed a stand for testing an amplifier from an aircraft gyro-horizon aggregate. Together with other inventors, Chiras made a compact apparatus for testing equipment and, whose idea was scooped up by the adroit men at the "Electrotekhnika" and "Radioelektronika" pavilions of the VDNKh of the USSR. These two inventions alone gave the enterprise a savings of over seven and a half thousand rubles.

In the course of the second stage of the inspection-competition "For Effectiveness and Quality" rationalizer A. Shorgin introduced seventeen proposals, among them small-gauge panels which lightened the work of specialists who use aviation equipment in stationary and field conditions. An instrument for controlling the operation and measurement of resistance in a relay winding, invented by a military employee, A. Murza, was subsequently exhibited at the VDNKh of the USSR and received a high evaluation from experts.

The detachment of inventors was filled with youths: Engineers, technicians, and workers. The specific weight of work submitted by them increased noticeably, and collectives earned the right to participate in NTM fairs. Army innovators demonstrated real creativity and mastery. Their inventions facilitated the improvement of operational methods for aviation technology and armament, growth of productive labor, an increase in technical education, as well as the resolution of a number of problems in the areas of economy and savings, which is what the decisions of the XXVI Congress of the CPSU were aiming at.

Especially high results in the past academic year were achieved by military collectives, where officers N. Osipov and P. Poberezhnyuk were members of the commission on inventions. Here, the search for the new became a standard practice for the personnel staff. This helps aviators acquire a deep knowledge and to operate aircraft and helicopters in a masterful way under any weather conditions, night and day, without failures or a proneness towards air incidents.

In these units and subunits, rationalizers always find the warm support from commanders, political workers, party organizations, and officers of the IAS. Thanks to their care, here were created necessary conditions for successful work of inventors. There are little corners for rationalizers, equipped with shelves with special literature, posters, and visual aids. There is material for visual agitation, in which the requirements of the XXVI Congress of the Communist Party are reflected, as well as the Minister of Defense of the USSR, and the Commander-in-Chief of the Air Force regarding questions of scientific-technical creativity. Excerpts from leading documents, conditions for examinations-competitions, etc. are spread around on stands.

Such enthusiasts-inventors and organizers as Lieutenant Colonel-Engineers P. Poberezhnyuk and N. Osipov give qualification consultations to aviators on working out and solving technical problems and on filling out the necessary documentation. There are regular meetings of the commission on inventions at which they look at how the competition is going, the completion of annual plans for rationalizers' work, the role of inventors in facilitating the completion of combat readiness plans, the solution to problems of raising combat readiness, the reliability of aviation technology, and flight safety.

Responsibilities are precisely distributed among the members of the commission (and these, as a rule, are communists and specialists of IAS units and subunits). Officers are responsible for the wide-scale introduction of the most valuable proposals, for the raising of inventors' qualification levels, posting visual agitation in the town and at the airbase, learning about patents, taking advantage of experience that is presented at the VDNKh of the USSR. Rationalizers' proposals are collected and introduced systematically every month in units. Experience has shown that the most logical timing for them is toward the end of the winter and summer training periods, when the personnel staff is preparing the technology for new operational conditions. During this period, the experience acquired over the past half-year is generalized, and technical conferences and seminars discuss the most effective operational modes and methods. In the course of these deliberations, the rationalizers draw conclusions for themselves, determine what should deserve their high-priority attention, and what inventions did not withstand the test of time.

Using different forms, activists popularize the resolutions of the CC CPSU and the Council of Ministers of the USSR on "The Future Development of This Country's Invention Affairs, Improvement in Using Discoveries, Inventions, and Rationalizers' Proposals in the National Economy, and Increasing Their Role in Accelerating Scientific-Technical Progress." This document is calculated for use over a prolonged period of time and is specific about inventors' activities. Knowledgeable propaganda work helps attract energetic and competent specialists to this important state matter.

Senior Lieutenant of Technical Service, N. Avdeyev, technician of an outstanding aircraft, used to think that inventors' and rationalizers' work was the fate of highly trained specialists with a great work record. Members of the commission on inventions convinced him and other young officers that rationalization work can be done by anyone. But, in order to achieve success, one must love technology, know the rules of dealing with it, know how to foresee weaknesses and anticipate defects, and apply a scientific organization of labor. Right now, N. Avdeyev is an active propagandist for scientific-technical creativity and the author of several devices. His portrait has been placed in a photo display case with other leaders and the

best unit rationalizers. The technician has been complimented more than once for his successes in combat and political training, and for his active participation in the inventors' movement.

Unit engineering sections are not inattentive to young inventors; they do everything to develop their talents and opportunities, and help them select contemporary themes for their work, using for this purpose analytical material for technology operations, information bulletins, and scientific-technical information, as well as material from technical periodicals. IAS leaders organize inspections to better resolve one or another of the problems.

In one aviation unit in particular, I saw prominently displayed posters calling on the personnel staff to participate in working out apparatuses or devices that would help decrease or eliminate blips on the inside surface of the cockpit canopy during night-time flights. Having read the conditions of the inspection and the technical requirements, the warriors were exchanging views. One felt that this call aroused them and awakened their creative thoughts.

Aviators of another unit, one in which officer S. Pokotilov is serving, are inviting representatives of civilian enterprises, innovators in production, and shock-workers of the eleventh Five-Year Plan to speak before army rationalizers. Here, seminars on inventiveness are conducted in an interesting and educational way. Beginning rationalizers are given an understanding of what constitutes an invention or a rationalizer's proposal; they explain what forms exist; what requirements have to be met in registering the documentation; and the rights and obligations of rationalizers, as well as the privileges accorded them. Lectures attract, in addition to unit service engineers, civilian experts out of patent sub-units.

Technical creativity is indivisibly tied to socialist competition. Aviators who have individual and collective responsibilities mark down specific objectives for themselves. Directors of enterprises and unit commanders cleverly use moral encouragement and material rewards for them. Winners of competitions are honored in a festive surrounding, where they are presented with authorial rights and given monetary rewards. One of the awards is a ticket to the country's Main Fair. Activists publish militant leaflets and express leaflets dedicated to the inventors.

Day-to-day direction of the inventors' movement is conducted through the commission on inventions. Commission members attend office consultations and meetings at which questions of competition between rationalizers are examined.

Right now the competition between rationalizers is becoming more widespread in anticipation of giving a worthy welcome to the Sixty-

Year anniversary of the founding of the USSR. Together with all the servicemen of the Armed Forces, the aviator-inventors are firm in their decision to multiply the achievements of their collectives and to attain new successes in combat readiness and in maintaining aviation technology in an unfailing manner.

COPYRIGHT: "Aviatsiya i kosmonavtika," 1982

11350

CSO: 9144/0605

END