

CONGRESS OF THE UNITED STATES
CONGRESSIONAL BUDGET OFFICE

AN

The Economic and Budget Outlook

UPDATE

19980914 011

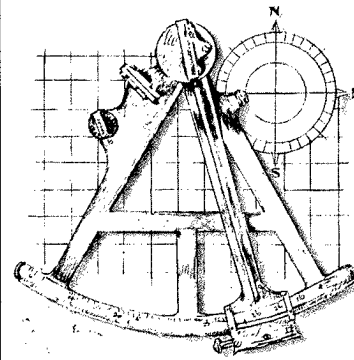
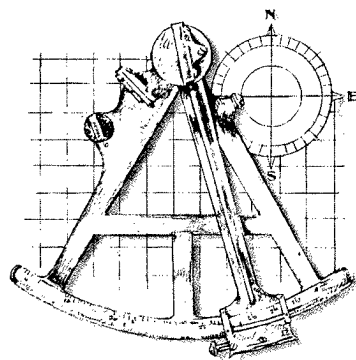
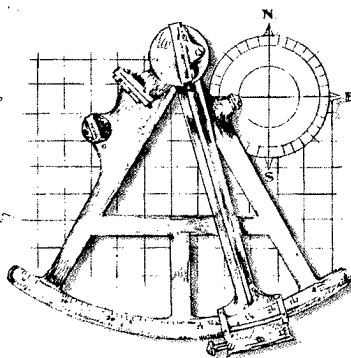
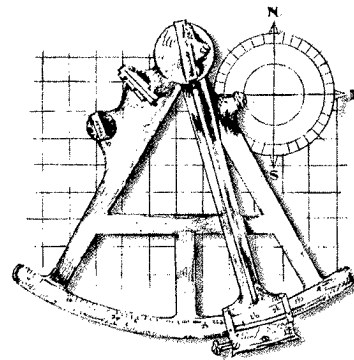
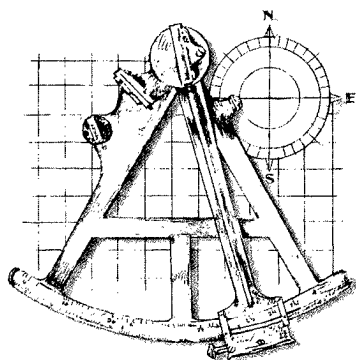

A REPORT TO THE SENATE AND
HOUSE COMMITTEES ON THE BUDGET



AUGUST 1998

DTIC QUALITY INSPECTED 1

**THE ECONOMIC AND BUDGET OUTLOOK:
AN UPDATE**

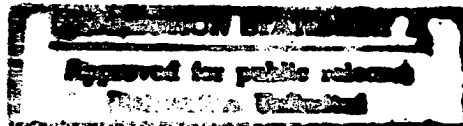

The Congress of the United States
Congressional Budget Office

NOTES

Unless otherwise indicated, all years referred to in Chapter 1 and Appendix A are calendar years, and all years in other chapters and Appendix B are fiscal years.

Some figures in this report indicate periods of recession by using shaded vertical bars. The bars extend from the peak to the trough of the recession.

Unemployment rates throughout the report are calculated on the basis of the civilian labor force.

The economic projections presented in this report differ slightly from those published in CBO's July 15, 1998, *Economic and Budget Outlook for Fiscal Years 1998-2008: A Preliminary Update* because they incorporate data released by the Bureau of Economic Analysis on July 31. The budget projections are unchanged from those presented in the preliminary report.

Numbers in the text and tables may not add up to totals because of rounding.

Preface

This volume is one of a series of reports on the state of the economy and the budget that the Congressional Budget Office (CBO) issues each year. It satisfies the requirement of section 202(e) of the Congressional Budget Act of 1974 for CBO to submit periodic reports to the Committees on the Budget with respect to fiscal policy and to provide baseline projections of the federal budget. In accordance with CBO's mandate to provide objective and impartial analysis, the report contains no recommendations.

The analysis of the economic outlook presented in Chapter 1 was prepared by the Macroeconomic Analysis Division under the direction of Robert Dennis and John F. Peterson. Matthew Salomon wrote the chapter, with substantial contributions from Robert Arnold, Juann Hung, and Kim Kowalewski. Michael Simpson carried out the economic forecast and projections. David Brauer, Ed Gamber, Douglas Hamilton, Mark Lasky, Angelo Mascaro, Benjamin Page, Frank Russek, Kent Smetters, John Sturrock, Jan Walliser, and Christopher Williams provided comments and background analysis. David Arnold and Ezra Finkin provided research assistance.

The baseline outlay projections were prepared by the staff of the Budget Analysis Division under the supervision of Paul N. Van de Water, Robert Sunshine, Priscilla Aycock, Tom Bradley, Paul Cullinan, Peter Fontaine, James Horney, and Michael Miller. The revenue estimates were prepared by the staff of the Tax Analysis Division under the supervision of Frank Sammartino and Richard Kasten. Jeffrey Holland wrote Chapter 2. Frank Sammartino and Richard Kasten wrote Chapter 3. Matthew Salomon and David Brauer wrote Appendix A, and Jennifer Winkler wrote Appendix B. James Horney wrote the summary of the report.

An early version of the economic forecast underlying this report was discussed at a meeting of CBO's Panel of Economic Advisers. Members of the panel are Alan Auerbach, Martin Bailey, Jagdish Bhagwati, Michael Boskin, Barry P. Bosworth, Robert Dederick, Martin Feldstein, Robert J. Gordon, Robert E. Hall, Marvin Kosters, Anne Krueger, N. Gregory Mankiw, Allan Meltzer, William Nordhaus, Rudolph Penner, James Poterba, Robert Reischauer, Sherwin Rosen, Joel Slemrod, John Taylor, and James Tobin. Andrew Abel, Martin Barnes, James Glassman, and Lawrence Kudlow attended as guests. Although these outside advisers provided considerable assistance, they are not responsible for the contents of this document.

Sherry Snyder supervised the editing of the report, and Kathryn Quattrone supervised production. Major portions were edited by Sherry Snyder, Melissa Burman, Leah Mazade, and Christian Spoor. The authors owe thanks to Marion Curry, Linda Lewis Harris, Denise Jordan, Dorothy Kornegay, and Simone Thomas, who assisted in the preparation of the report. Kathryn Quattrone prepared the report for final publication, with assistance from Martina Wojak-Piotrow. Laurie Brown prepared the electronic versions for CBO's Web site.

June E. O'Neill
Director

August 1998

This study and other CBO publications
are available at CBO's Web site:
<http://www.cbo.gov/>

Contents

	SUMMARY	ix
ONE	THE ECONOMIC OUTLOOK	1
	The Current State of the Economy	2
	The Economic Forecast for 1998 and 1999	15
	The Economic Projection for 2000 Through 2008	20
	Uncertainty in the Economic Outlook	24
TWO	THE BUDGET OUTLOOK	33
	An Improved Bottom Line	34
	Changes in Projections Since March	36
	Revenue and Spending Projections	40
	The Federal Sector of the National Income and Product Accounts	42
THREE	THE REVENUE OUTLOOK	49
	Key Factors in Projecting Revenues	51
	Revenue Estimates for 1999 and 2000	54
	The Longer-Term Revenue Outlook	56
	APPENDIXES	
A	Evaluating CBO's Record of Economic Forecasts	63
B	Sequestration Update Report for Fiscal Year 1999	79
C	Major Contributors to the Revenue and Spending Projections	85

TABLES

S-1.	The Budget Outlook Under Current Policies	x
S-2.	Comparison of CBO's Summer and January 1998 Economic Projections for Calendar Years 1998-2008	xi
S-3.	Changes in CBO Budget Projections Since March 1998	xiv
S-4.	CBO Baseline Budget Projections, Assuming Compliance with Discretionary Spending Caps	xvi
1-1.	The CBO Forecast for 1998 and 1999	2
1-2.	The CBO Economic Projection for Calendar Years 1998-2008	16
1-3.	The CBO Economic Projection for Fiscal Years 1998-2008	17
1-4.	Key Assumptions for the Projection of Potential Output	21
1-5.	Comparison of CBO's Summer and January 1998 Economic Projections for Calendar Years 1998-2008	25
1-6.	Comparison of CBO's and Other Economists' Forecasts for 1998 and 1999	28
1-7.	Comparison of CBO's and Other Economists' Projections for Calendar Years 1998-2008	29
2-1.	The Budget Outlook Under Current Policies	35
2-2.	Changes in CBO Budget Projections Since March 1998	38
2-3.	CBO Budget Projections, Assuming Compliance with Discretionary Spending Caps	41
2-4.	CBO Projections of Discretionary Outlays, Assuming Compliance with Discretionary Spending Caps	42
2-5.	CBO Projections of Mandatory Spending, Including Deposit Insurance	43
2-6.	CBO Projections of Federal Interest Costs and Debt	44
2-7.	Relationship of the Budget to the Federal Sector of the National Income and Product Accounts	45
2-8.	Projections of Receipts and Expenditures Measured by the National Income and Product Accounts	46
3-1.	CBO Revenue Projections	51
3-2.	Comparison of CBO's July and January 1998 Projections of Federal Revenues for Fiscal Year 1998	52

3-3.	Revenues, by Source, Since Fiscal Year 1985	55
3-4.	Average Annual Growth Rates of Income and Revenues for 1959-1997 and Projected Through 2008	58
3-5.	CBO Projections for Individual, Corporate, and Social Insurance Receipts and Their Tax Bases	59
A-1.	Comparison of CBO, Administration, and <i>Blue Chip</i> Forecasts of Two-Year Average Growth Rates for Real Output	71
A-2.	Comparison of CBO, Administration, and <i>Blue Chip</i> Forecasts of Two-Year Average Inflation Rates in the Consumer Price Index	72
A-3.	Comparison of CBO, Administration, and <i>Blue Chip</i> Forecasts of Two-Year Average Interest Rates on Three-Month Treasury Bills	73
A-4.	Comparison of CBO, Administration, and <i>Blue Chip</i> Forecasts of Two-Year Average Long-Term Interest Rates	74
A-5.	Comparison of CBO, Administration, and <i>Blue Chip</i> Forecasts of Two-Year Average Real Interest Rates on Three-Month Treasury Bills	75
A-6.	Comparison of CBO and Administration Projections of the Two-Year Change in Wage and Salary Distributions Plus Book Profits as a Share of Output	76
A-7.	Comparison of CBO, Administration, and <i>Blue Chip</i> Projections of Five-Year Average Growth Rates for Real Output	77
B-1.	CBO Estimates of Discretionary Spending Limits for Fiscal Years 1998-2002	82
B-2.	Budgetary Effects of Direct Spending or Receipt Legislation Enacted Since the Budget Enforcement Act of 1997	84
 FIGURES		
1-1.	The Economic Forecast and Projection	3
1-2.	Household Net Worth	4
1-3.	Labor Productivity	6
1-4.	Medical Care Inflation	7
1-5.	Benefits per Hour	7

1-6.	Corporate Profits, Interest Costs, and Health Benefit Costs	8
1-7.	Volatility in the Core Rate of CPI Inflation	9
1-8.	The Personal Saving Rate	9
1-9.	The U.S. Dollar Exchange Rate and Import Price Inflation	13
1-10.	Commodity and Crude Oil Prices	13
1-11.	Changes in the Prices of Key Computer Components	14
1-12.	Tightness in the Labor Market and Wage Growth	15
1-13.	Real Inventory Stocks	20
1-14.	Trade Deficit	20
1-15.	Business Fixed Investment	22
2-1.	Debt Held by the Public as a Share of GDP	33
2-2.	Total and On-Budget Deficit or Surplus	36
3-1.	Federal Revenues as a Share of GDP	49
3-2.	Annual Growth of Federal Revenues and GDP	50
3-3.	Annual Growth of Taxable Capital Gains Realizations	53
3-4.	Annual Growth of Income and GDP	56
3-5.	Revenues, by Source, as a Share of GDP	57

BOXES

1-1.	The Cloud of the Asian Crisis Lingers On	10
1-2.	The Impact of the Stock Market on the Economy	19
1-3.	Revision of the National Income and Product Accounts	26
2-1.	CBO's Long-Term Budget Outlook	37

Summary

The Congressional Budget Office (CBO) projects that the federal budget for fiscal year 1998 will record a total surplus of \$63 billion, or 0.8 percent of gross domestic product (GDP). If current policies remain unchanged, the surplus is expected to rise to \$80 billion in 1999 and reach \$251 billion (nearly 2 percent of GDP) by 2008 (see Summary Table 1). Excluding the surplus in Social Security and the net outlays of the Postal Service (both of which are legally classified as off-budget), CBO's new projections show an on-budget deficit of \$41 billion in 1998, which gives way to surpluses in 2002 and in 2005 through 2008.

The budget outlook has improved significantly in the past six months. Unexpectedly strong revenue collections by the Treasury in the first 10 months of fiscal year 1998 are the major reason that CBO has gone from projecting a small deficit last January to estimating a surplus of \$63 billion today. The strength of 1998 revenues, together with a slightly more optimistic economic outlook, also forms the basis for increases in CBO's projections of the surplus for 1999 through 2008.

Based on collections through July, CBO believes that 1998 revenues will total \$1,717 billion—\$38 billion (2.2 percent) higher than CBO's March estimate and \$53 billion (3.2 percent) higher than the January estimate. New economic data explain less than \$7 billion of the increase in the projection since January, while new legislation is responsible for \$1 billion. That leaves \$45 billion, almost all in revenues from

individual income taxes, to be explained by other factors.

At this point, there is little firm information about the sources of income that produced the added revenues in 1998 and their implications for revenue growth in future years. Some of the factors that might explain the additional income are likely to be temporary and would fade over several years. But others are more permanent and could spur continuous revenue growth. After assessing the possible causes, CBO has assumed that, on balance, the factors producing the additional revenues in 1998 will continue to add a similar dollar amount to revenues in future years. That amount, however, raises projected revenues by increasingly smaller percentages over time.

Changes in the economic outlook also boost surpluses projected over the next decade. A smaller expected decline in corporate profits as a share of GDP increases projected revenues, and slightly lower real (inflation-adjusted) long-term interest rates after 2000 reduce interest payments on the national debt. A reduction in the projected rate of inflation—which holds down required cost-of-living increases, the growth of Medicare costs, nominal interest rates, and assumed increases in discretionary spending after 2002—significantly lowers projected outlays in the longer term. But lower inflation does not have a major impact on the surplus because it also slows the growth of taxable incomes, leading to a reduction in projected tax revenues that offsets the reduction in outlays.

Summary Table 1.**The Budget Outlook Under Current Policies (By fiscal year, in billions of dollars)**

	Actual 1997	1998	1999	2000	2001	2002	2003	2004	2005	2006	2007	2008
Total Deficit (-) or Surplus	-22	63	80	79	86	139	136	154	170	217	236	251
Off-Budget Surplus	81	104	117	125	131	138	146	154	165	173	181	186
On-Budget Deficit (-) or Surplus (Excluding Social Security and Postal Service)	-103	-41	-37	-46	-45	1	-10	a	5	44	55	64

SOURCE: Congressional Budget Office.

a. Less than \$500 million.

CBO now expects lower outlays in 1998 than it projected in March, but that decrease largely reflects temporary factors that are not expected to reduce spending in the future. Legislation enacted since March has lowered projected surpluses by a few billion dollars a year—primarily reflecting higher spending for transportation programs.

The Economic Outlook

The economy has continued to grow at a healthy pace, with low unemployment and subdued inflation. CBO projects that growth will slow over the next few years and that the unemployment and inflation rates will gradually rise (see Summary Table 2). The current outlook is not dramatically different from CBO's last economic projections, made in January, but small increases in real growth, somewhat lower inflation, profits that account for a larger share of GDP, and lower real long-term interest rates significantly affect the budget's projected bottom line.

The Forecast for 1998 and 1999

The growth of real GDP is likely to slow to just over 2 percent for the rest of calendar year 1998 and early 1999, down from the 4 percent pace set during 1997 and the 5.5 percent pace during the first quarter of

1998. Factors contributing to the slowdown include a continuation of the recent increase in the real trade deficit, a pickup in inflation, and weaker profits.

Demand for U.S.-produced goods and services has been dampened by the economic contraction in Asia, as well as by an already strong dollar and slowly growing demand in Europe. It is likely that foreign trade will continue to depress demand for U.S. goods into 1999.

The underlying rate of inflation—the increase in the consumer price index (CPI) excluding energy and food prices—is forecast to rise slightly over the next year and a half. Strong upward pressure on wages is expected to contribute to that increase. In addition, some factors that have held down CPI growth over the past two or three years are expected to have less of an effect in the future. For example, import price deflation is expected to fade during 1999, and medical care inflation is forecast to bounce back from the low levels of the past two years.

Corporate profits, which have stagnated since the third quarter of last year, will remain under pressure through 1999. Rising wages and an expected increase in the growth of employee benefits will push the growth of total compensation higher at the same time that sales growth slows. Some of those costs will be passed on in the form of higher prices, but some will be absorbed through lower profits.

Summary Table 2.
Comparison of CBO's Summer and January 1998 Economic Projections for Calendar Years 1998-2008

	Actual 1997	Forecast		Projected								
		1998	1999	2000	2001	2002	2003	2004	2005	2006	2007	2008
Nominal GDP												
(Billions of dollars)												
Summer 1998	8,111	8,487	8,839	9,204	9,572	10,008	10,475	10,955	11,446	11,950	12,473	13,015
January 1998	8,081	8,461	8,818	9,195	9,605	10,046	10,529	11,038	11,565	12,112	12,684	13,280
Nominal GDP												
(Percentage change)												
Summer 1998	5.9	4.6	4.2	4.1	4.0	4.6	4.7	4.6	4.5	4.4	4.4	4.3
January 1998	5.8	4.7	4.2	4.3	4.5	4.6	4.8	4.8	4.8	4.7	4.7	4.7
Real GDP^a												
(Percentage change)												
Summer 1998	3.9	3.4	2.2	1.9	1.8	2.4	2.5	2.4	2.3	2.3	2.2	2.2
January 1998	3.7	2.7	2.0	1.9	2.0	2.1	2.3	2.3	2.2	2.2	2.2	2.1
GDP Price Index^b												
(Percentage change)												
Summer 1998	1.9	1.2	2.0	2.2	2.1	2.1	2.1	2.1	2.1	2.1	2.1	2.1
January 1998	2.0	2.0	2.2	2.3	2.4	2.4	2.5	2.5	2.5	2.5	2.5	2.5
Consumer Price Index^c												
(Percentage change)												
Summer 1998	2.3	1.7	2.6	2.7	2.6	2.5	2.5	2.5	2.5	2.5	2.5	2.5
January 1998	2.3	2.2	2.5	2.7	2.8	2.8	2.8	2.8	2.8	2.8	2.8	2.8
Unemployment Rate												
(Percent)												
Summer 1998	4.9	4.6	4.7	5.1	5.5	5.7	5.7	5.7	5.7	5.7	5.7	5.7
January 1998	4.9	4.8	5.1	5.4	5.6	5.8	5.9	5.9	5.9	5.9	5.9	5.9
Three-Month Treasury												
Bill Rate (Percent)												
Summer 1998	5.1	5.1	5.2	4.8	4.6	4.4	4.4	4.4	4.4	4.4	4.4	4.4
January 1998	5.1	5.3	5.2	4.8	4.7	4.7	4.7	4.7	4.7	4.7	4.7	4.7
Ten-Year Treasury												
Note Rate (Percent)												
Summer 1998	6.4	5.8	6.1	5.8	5.6	5.4	5.4	5.4	5.4	5.4	5.4	5.4
January 1998	6.4	6.0	6.1	6.0	5.9	5.9	5.9	5.9	5.9	5.9	5.9	5.9
Tax Bases												
(Percentage of GDP)												
Corporate profits ^d												
Summer 1998	10.1	9.6	9.4	9.2	8.8	8.6	8.5	8.5	8.4	8.3	8.3	8.3
January 1998	9.9	9.7	9.2	8.8	8.5	8.3	8.2	8.1	8.0	7.9	7.8	7.7
Wage and salary disbursements												
Summer 1998	48.0	48.7	48.8	48.7	48.8	48.7	48.7	48.7	48.7	48.7	48.7	48.7
January 1998	48.0	48.4	48.5	48.6	48.6	48.6	48.6	48.7	48.8	48.8	48.8	48.8
Other taxable income												
Summer 1998	21.2	20.9	20.8	20.5	20.2	20.0	19.8	19.6	19.4	19.2	19.1	18.9
January 1998	22.1	21.8	21.5	21.2	21.1	20.9	20.7	20.5	20.4	20.2	20.1	20.0

SOURCES: Congressional Budget Office; Department of Commerce, Bureau of Economic Analysis; Department of Labor, Bureau of Labor Statistics; Federal Reserve Board.

- a. Based on chained 1992 dollars.
- b. The GDP price index is virtually the same as the implicit GDP deflator.
- c. The consumer price index for all urban consumers.
- d. Corporate profits are the profits of corporations, adjusted to remove the distortions in depreciation allowances caused by tax rules and to exclude capital gains on inventories.

The anticipated rise in inflation may lead to higher interest rates, but any increase is likely to be mild and temporary. If the Federal Reserve Board is uncertain about the pervasiveness of the slowdown in economic activity, an increase in inflation may prompt it to raise short-term rates by the end of the year. Long-term rates may also pick up slightly. However, if economic growth slows to a 2 percent rate for 1999, short-term interest rates will probably ease back to their current levels by the end of that year.

The Projection for 2000 Through 2008

CBO does not forecast cyclical economic effects beyond two years. Instead, it calculates a medium-term path of the economy that reflects the possibility of booms and recessions. That midrange path is the baseline projection of the economy for 2000 through 2008. Over that period, CBO expects real GDP to grow at an average rate of 2.3 percent a year, the CPI to increase at an average rate of 2.5 percent, and short-term interest rates to average 4.5 percent.

The small variations in real GDP growth and other variables during that period that are apparent in Summary Table 2 do not stem from any assumptions about cyclical effects in those years. The slight drop in the projected growth rate of real GDP between 2002 and 2008 reflects a demographic assumption that growth of the labor force will slow in line with slower growth of the working-age population and an assumption that growth of investment will return to a lower, long-term trend. In order to achieve the projected average values assumed over the 2000-2008 period without having a misleadingly sudden drop at the end of 1999, CBO phases in reductions in inflation, interest rates, and profits as a share of GDP over the first few years of the projection period.

Changes Since January

CBO now forecasts that real GDP in 1998 will be higher than it anticipated in January and projects that real GDP will grow, on average, about 0.1 percentage point a year faster over the entire 1998-2008 period than was projected at that time.

Inflation, whether measured by the consumer price index or the GDP price index, is lower this year than was forecast in January, largely because of a drop in energy prices. Inflation is expected to rise over the next two years, with the increase in the CPI projected to grow from 1.7 percent in 1998 to 2.7 percent in 2000. However, the average growth rate for the CPI from 2002 through 2008 is projected to be 2.5 percent a year—about 0.3 percentage points lower than had been projected in January. Because of changes that the Bureau of Labor Statistics has made or plans to make in how it measures the CPI, the 2.7 percent inflation projected for 2000 is comparable to 3.4 percent inflation calculated on the basis of the measurement techniques used before 1995. The Federal Reserve Board is unlikely to be satisfied with inflation at that rate over a long period; thus, CBO assumes that inflation will be lower, on average, after 2000.

The GDP price index is also projected to increase at a slower pace than CBO anticipated in January. That assumption of lower inflation significantly reduces both nominal GDP and the total national income and product account (NIPA) tax base in the latter years of the projection period. As a share of GDP, however, the total tax base is higher in the current projection than it was in January. Corporate profits as a share of GDP in 1998 and 1999 are similar to the previous forecast, but the projection for subsequent years is significantly higher than before (although the share still drops over time). CBO increased that projection because of lower projected interest rates, which reduce the debt-service costs of companies and boost profits. The projection for wages and salaries as a share of GDP has changed little since January.

Nominal interest rates are lower than previously projected because of the assumed decline in inflation. The outlook for inflation-adjusted short-term interest rates is unchanged from January. However, inflation-adjusted long-term rates are projected to be lower because of the larger projected federal surpluses.

Uncertainty of the Outlook

One source of errors in predicting the future performance of the economy is data on its recent perfor-

mance. Reported data on GDP and the components of national income are regularly revised, sometimes by quite large amounts. Because forecasts necessarily depend on the economic data that are currently available, the likelihood of revisions to those data increases the uncertainty of any forecast.

In addition, there is a risk that future events will cause a significant divergence from the path laid out in the new forecast. The economy could be more adversely affected by the Asian crisis than CBO assumes; the tightness of the labor market could cause a significant jump in the rate of inflation; or the stock market could drop precipitously. Conversely, the Asian crisis could have little additional effect on the United States; productivity growth might remain higher than CBO anticipates, which would permit a continuation of rapid noninflationary growth and stronger profits; or labor force participation rates might again increase rapidly, easing pressures on the labor market for a few years. Such alternative outcomes could have a substantial effect on the budget, increasing or decreasing its bottom line by \$100 billion or more in a single year.

The Budget Outlook

In March, CBO projected that the total federal budget would show a surplus of \$8 billion in fiscal year 1998—the first surplus in almost 30 years—but warned that the final budget numbers for the year could quite easily show a small deficit or a larger surplus. With actual spending and revenues reported for more than three-quarters of the fiscal year, a surplus this year is now virtually certain, and CBO has boosted its projection of that surplus to \$63 billion (see Summary Table 3). Moreover, the improvement in the budget outlook for 1998—primarily associated with higher-than-anticipated revenues—seems likely to carry over to future years as well. Assuming that policies remain unchanged, CBO projects that the surplus will generally increase over the next 10 years, reaching \$251 billion (1.9 percent of GDP) in 2008.

Although the total budget is expected to show a healthy surplus in 1998, CBO expects that there will still be an on-budget deficit. On-budget revenues

(which by law exclude revenues earmarked to Social Security) are projected to be \$41 billion less than on-budget spending (which excludes spending for Social Security benefits and administrative costs and the net outlays of the Postal Service, but includes general fund interest payments to the Social Security trust funds). By 2002, and in 2005 through 2008, the budget will be in surplus even when off-budget revenues and spending are excluded from the calculation.

Changes Since March

Actual revenues for 1998 reported by the Treasury have been higher and actual outlays have been lower than CBO had projected in March. Revenues now seem likely to reach \$1,717 billion this year, \$38 billion (2.2 percent) higher than the March estimate and \$53 billion (3.2 percent) higher than CBO projected in January. CBO also expects total outlays of \$1,654 billion this year, \$18 billion (1.1 percent) less than projected in March.

The additional revenues in 1998 have led CBO to boost its projection of revenues in later years because at least some of the factors that have pushed up incomes and 1998 tax revenues will probably continue to have an impact. The reductions in 1998 spending, by contrast, result largely from temporary factors and have little effect on CBO's projections of spending beyond 1998.

CBO's spending and revenue projections incorporate the effects of legislation enacted since March, but those effects are relatively small. Changes prompted by CBO's new economic projections have had a larger effect on the budget projections, but not nearly as large as the revisions stemming from the increased 1998 revenues. The most significant change in the economic outlook is a decline in projected inflation, but that change has a limited impact on projected surpluses because it lowers both spending and revenues.

Changes in Projected Revenues. In January, CBO predicted that revenues would total \$1,665 billion in 1998. That projection was based on actual collections reported through November, economic data available at that time, and CBO's forecast of economic activity through the rest of the year. In March, actual collec-

tions reported through January led CBO to raise its projection to \$1,680 billion. Based on actual collections reported through July, revised economic data, and a new economic forecast, CBO now expects total collections of \$1,717 billion for the year. Revisions to data on aggregate wages and salaries, corporate profits, and other variables reported in the national income and product accounts, and to CBO's forecast of those NIPA variables, explain only about \$7 billion of the \$53 billion increase in projected revenues since January. Legislation enacted since March explains an additional \$1 billion of the increase. That leaves a \$45 billion increase in expected revenues to be explained by other factors.

What is known from the data on actual collections is that the \$45 billion increase in the projection results almost entirely from additional individual income tax receipts. However, available data provide virtually no information about the sources of the increased income that generated those tax collections. A well-founded explanation of the unexpected revenues would require detailed information from tax returns about the particular sources of income and other factors that generated tax liabilities in calendar years 1997 and 1998. But such information is available only through 1996. Sufficient data on 1997 incomes and tax liabilities will not be available until late this year, and data on 1998 liabilities will not be available until late 1999.

Summary Table 3.
Changes in CBO Budget Projections Since March 1998 (By fiscal year, in billions of dollars)

	1998	1999	2000	2001	2002	2003	2004	2005	2006	2007	2008
March 1998 Total Budget Surplus	8	9	1	13	67	53	70	75	115	130	138
Changes											
Legislative											
Revenues	1	1	a	-1	-1	-1	-1	1	1	1	1
Outlays ^b	-1	-3	-4	-4	-4	-3	-2	-1	-1	a	1
Subtotal	b	-2	-4	-5	-5	-4	-4	b	1	1	2
Economic											
Revenues	7	13	15	5	a	-3	-10	-17	-24	-33	-43
Outlays	1	9	10	12	16	24	32	40	48	56	63
Subtotal	8	22	25	17	16	21	22	24	23	23	21
Technical											
Revenues	30	48	50	51	49	50	49	51	52	52	55
Outlays ^b											
Other than debt service	16	-1	a	-1	-1	a	-2	-1	a	1	1
Debt service	1	4	7	10	13	16	19	22	26	30	34
Subtotal	48	51	57	61	61	66	65	72	78	83	90
Total Changes	55	71	78	73	72	82	84	96	102	106	113
Summer 1998 Total Budget Surplus	63	80	79	86	139	136	154	170	217	236	251
Memorandum:											
Total Change in Revenues	38	62	65	56	48	46	37	35	29	20	13
Total Change in Outlays	18	9	13	17	23	37	46	61	73	86	99

SOURCE: Congressional Budget Office.

a. Less than \$500 million.

b. Increases in outlays are shown with a negative sign because they reduce surpluses.

How the 1998 revenue surge should influence projections of future revenues depends on which of a number of possible factors were actually responsible for the unexplained revenues, and to what extent. For example, if subsequent revisions reveal that incomes in the recent past were higher than has been reported in the NIPA data, that discrepancy could have an effect that grows over time at roughly the rate of the projected growth in incomes. But other likely factors, such as a surge in capital gains realizations and a jump in the incomes of higher-income taxpayers associated with recent stock market gains, could have a diminishing effect on future revenue growth.

Faced with limited information about the weights to give to the various possibilities, CBO has chosen a middle path. Its projections assume that the factors boosting revenues in recent years will neither fade rapidly nor produce increasing amounts of revenues. That assumption, along with small changes resulting from other adjustments, generates the technical changes to revenues shown in Summary Table 3. (Technical changes are those that are not attributable to legislation or the economy.)

CBO also revised its revenue projections to reflect legislation enacted since March, primarily the Internal Revenue Service Restructuring and Reform Act of 1998. Those changes increase revenues in some years, decrease them in others, and boost them by a total of \$3 billion over the 1998-2008 period.

Changes in CBO's economic projections affected revenues much more substantially than did legislation. Over the next few years, the revised economic assumptions increase revenues by as much as \$15 billion a year. But after 2002, the revised outlook reduces revenues by amounts that grow to \$43 billion in 2008. Slightly higher real GDP and a not-quite-as-sharp decline in corporate profits as a share of GDP boost projected revenues. However, lower projected inflation pushes down nominal GDP and incomes, resulting in a drop in revenues that more than offsets those upward effects after 2002. Because lower inflation also pushes down spending, that reduction in revenues does not have a major impact on the budget surplus.

Changes in Projected Outlays. CBO anticipates that 1998 outlays will be \$18 billion lower than projected in March. About \$5 billion of that reduction occurs in

discretionary spending. A supplemental appropriation bill enacted in May boosted discretionary outlays by an estimated \$1 billion, but that increase was more than offset by slower-than-anticipated spending for a number of programs.

Lower projected mandatory spending in 1998 accounts for the remaining \$12 billion in decreased outlays. More than \$1 billion of that reflects economic effects—unemployment and interest rates that are lower than previously anticipated. Legislation enacted since March has had virtually no effect on net mandatory spending. Thus, the leftover \$11 billion reduction in projected mandatory spending is attributable to other, technical factors. More than \$3 billion of the reduction is in Medicare, largely the result of a decision by the Health Care Financing Administration to slow the processing of payments to health care providers.

Lower outlays in 1998 have not led to a reduction in projected spending in 1999 through 2008. The 1998 reductions largely reflect one-time events that either have no impact on future spending or are likely to increase it. For example, the slowdown in the processing of Medicare payments will lower 1998 spending but will have little or no effect on spending in future years, since the amount saved in any year because of the delay will roughly equal the amount that is carried over to that year from the previous year.

Legislation enacted since March has increased projected spending over the 1999-2008 period by a total of \$23 billion. Most of that increase stems from the additional spending provided by the Transportation Equity Act for the 21st Century, enacted in June.

Changes in CBO's economic projections have reduced projected spending by amounts that grow to \$63 billion by 2008. A slight reduction in anticipated real long-term interest rates produces savings in interest on the national debt. Much more significant, however, are the reductions in spending that result from lower projected inflation. Lower inflation holds down the size of required cost-of-living adjustments for benefit programs such as Social Security, slows the growth of Medicare spending, and by lowering nominal interest rates, curbs spending for interest on the debt. Since CBO's projections assume that discretionary spending will grow at the rate of inflation after the

statutory caps on such spending expire in 2002, the decline in projected inflation also reduces discretionary spending projected for 2003 through 2008. Lower inflation has a small effect on the surplus, however, because it reduces revenues by at least as much as outlays.

Current Revenue Projections for 1998 Through 2008

CBO projects that revenues will grow about 3.5 percentage points faster than the economy in 1998, reaching 20.5 percent of GDP—a post-World War II high. In 1999, revenues are projected to grow only slightly faster than the economy and will equal 20.6 percent of

GDP (see Summary Table 4). After that, revenues are expected to decline gradually as a percentage of GDP through 2003 (when they will equal 19.8 percent) and then grow at the same rate as the economy through 2008. Despite the decline (as a percentage of GDP) from the 1999 high point, the 19.8 percent level projected for revenues in 2003 through 2008 is equal to the level attained in 1997. Thus, even with tax cuts in the Taxpayer Relief Act of 1997 that reduce revenues by an estimated 0.3 percent of GDP a year, revenues are projected to equal a larger share of GDP than in any postwar year before 1997.

Although CBO assumes that the unexplained increase in 1998 revenues carries over into 1999, the projected growth rate of revenues drops sharply, from 8.7 percent in 1998 to 4.9 percent in 1999. That drop

Summary Table 4.
CBO Baseline Budget Projections, Assuming Compliance with Discretionary Spending Caps
(By fiscal year)

	Actual 1997	1998	1999	2000	2001	2002	2003	2004	2005	2006	2007	2008
In Billions of Dollars												
Revenues												
Individual income	737	821	850	867	892	933	968	1,014	1,065	1,116	1,170	1,227
Corporate income	182	190	196	201	201	204	210	218	228	239	250	262
Social insurance	539	577	604	629	652	678	706	737	772	805	839	871
Other	<u>120</u>	<u>129</u>	<u>150</u>	<u>152</u>	<u>157</u>	<u>163</u>	<u>169</u>	<u>174</u>	<u>178</u>	<u>182</u>	<u>187</u>	<u>193</u>
Total	1,579	1,717	1,801	1,848	1,903	1,978	2,053	2,142	2,243	2,342	2,446	2,553
On-budget	1,187	1,296	1,359	1,388	1,425	1,481	1,534	1,601	1,675	1,750	1,829	1,911
Off-budget	392	421	442	460	478	497	519	541	568	592	618	643
Outlays												
Discretionary spending	548	552	564	569	570	567	581	595	610	626	641	657
Mandatory spending	896	942	997	1,052	1,115	1,165	1,234	1,303	1,389	1,443	1,531	1,626
Offsetting receipts	-87	-84	-79	-84	-90	-101	-96	-99	-104	-109	-115	-121
Net interest	<u>244</u>	<u>244</u>	<u>238</u>	<u>232</u>	<u>221</u>	<u>209</u>	<u>198</u>	<u>189</u>	<u>178</u>	<u>166</u>	<u>153</u>	<u>140</u>
Total	1,601	1,654	1,721	1,769	1,817	1,840	1,918	1,988	2,073	2,126	2,211	2,303
On-budget	1,291	1,337	1,396	1,434	1,470	1,480	1,545	1,601	1,670	1,706	1,774	1,846
Off-budget	311	317	325	335	347	359	373	387	402	419	437	456
Deficit (-) or Surplus												
On-budget deficit (-) or surplus	-22	63	80	79	86	139	136	154	170	217	236	251
Off-budget surplus	-103	-41	-37	-46	-45	1	-10	a	5	44	55	64
	81	104	117	125	131	138	146	154	165	173	181	186
Debt Held by the Public	3,771	3,717	3,655	3,589	3,518	3,395	3,275	3,136	2,981	2,779	2,557	2,320

is attributable in part to economic factors—the growth in taxable incomes is projected to slow to 4.1 percent in 1999, down from 5.8 percent in 1998. The rest comes from assuming that the factors responsible for the unexplained revenues in 1998 will add the same amount to 1999 revenues. Should those factors increase in strength, revenues would rise at a faster rate. However, if the unexplained revenues in 1998 resulted largely from temporary factors, the rate of growth of revenues in 1999 could decline more precipitously.

Even if revenues continue to grow rapidly in 1999, CBO believes the rate of growth will eventually slow. Because of the scheduled tax cuts provided by

the Taxpayer Relief Act, and because corporate profits are expected to fall as a share of GDP, CBO projects that over the next 10 years, the average growth rate of revenues will be slightly lower than the growth rate of the economy. Revenues are projected to grow at the same rate as GDP from 2003 through 2008. During that period, individual income tax revenues will grow faster than GDP because tax brackets are indexed for inflation but not for changes in real income, which boosts the effective tax rate as real income grows. But excise tax revenues will grow more slowly than GDP because many rates are fixed in nominal terms.

Summary Table 4.
Continued

	Actual 1997	1998	1999	2000	2001	2002	2003	2004	2005	2006	2007	2008
As a Percentage of GDP												
Revenues												
Individual income	9.3	9.8	9.7	9.5	9.4	9.4	9.3	9.3	9.4	9.4	9.5	9.5
Corporate income	2.3	2.3	2.2	2.2	2.1	2.1	2.0	2.0	2.0	2.0	2.0	2.0
Social insurance	6.8	6.9	6.9	6.9	6.9	6.8	6.8	6.8	6.8	6.8	6.8	6.8
Other	<u>1.5</u>	<u>1.5</u>	<u>1.7</u>	<u>1.7</u>	<u>1.7</u>	<u>1.6</u>	<u>1.6</u>	<u>1.6</u>	<u>1.6</u>	<u>1.5</u>	<u>1.5</u>	<u>1.5</u>
Total	19.8	20.5	20.6	20.3	20.1	20.0	19.8	19.8	19.8	19.8	19.8	19.8
On-budget	14.9	15.4	15.5	15.2	15.0	15.0	14.8	14.8	14.8	14.8	14.8	14.8
Off-budget	4.9	5.0	5.0	5.0	5.0	5.0	5.0	5.0	5.0	5.0	5.0	5.0
Outlays												
Discretionary spending	6.9	6.6	6.4	6.2	6.0	5.7	5.6	5.5	5.4	5.3	5.2	5.1
Mandatory spending	11.2	11.2	11.4	11.5	11.8	11.8	11.9	12.0	12.3	12.2	12.4	12.6
Offsetting receipts	-1.1	-1.0	-0.9	-0.9	-0.9	-1.0	-0.9	-0.9	-0.9	-0.9	-0.9	-0.9
Net interest	<u>3.1</u>	<u>2.9</u>	<u>2.7</u>	<u>2.5</u>	<u>2.3</u>	<u>2.1</u>	<u>1.9</u>	<u>1.7</u>	<u>1.6</u>	<u>1.4</u>	<u>1.2</u>	<u>1.1</u>
Total	20.1	19.7	19.7	19.4	19.2	18.6	18.5	18.3	18.3	18.0	17.9	17.9
On-budget	16.2	15.9	15.9	15.7	15.5	14.9	14.9	14.8	14.7	14.4	14.4	14.3
Off-budget	3.9	3.8	3.7	3.7	3.7	3.6	3.6	3.6	3.6	3.5	3.5	3.5
Deficit (-) or Surplus												
On-budget deficit (-) or surplus	-0.3	0.8	0.9	0.9	0.9	1.4	1.3	1.4	1.5	1.8	1.9	1.9
Off-budget surplus	-1.3	-0.5	-0.4	-0.5	-0.5	b	-0.1	b	b	0.4	0.4	0.5
Debt Held by the Public	1.0	1.2	1.3	1.4	1.4	1.4	1.4	1.4	1.5	1.5	1.5	1.4
Debt Held by the Public	47.3	44.3	41.7	39.3	37.1	34.3	31.6	28.9	26.3	23.5	20.7	18.0

SOURCE: Congressional Budget Office.

a. Deficit of less than \$500 million.

b. Deficit or surplus of less than 0.05 percent of GDP.

Current Outlay Projections for 1998 Through 2008

In dollar terms, total outlays are projected to grow from \$1,654 billion in 1998 to \$2,303 billion in 2008. But as a percentage of GDP, they are projected to decline throughout the period—from 19.7 percent of GDP in 1998 to 17.9 percent in 2008.

Net interest, which was the fastest-growing category of spending in the 1980s, is now projected to decline from \$244 billion (2.9 percent of GDP) in 1998 to \$140 billion (1.1 percent of GDP) in 2008 as projected surpluses reduce the stock of debt held by the public by \$1.4 trillion. Discretionary spending is projected to increase from \$552 billion to \$657 billion over that period but to shrink relative to the size of the economy—from 6.6 percent of GDP to 5.1 percent. By contrast, mandatory spending is expected to increase both in nominal terms (from \$942 billion to \$1,626 billion) and as a percentage of GDP (from 11.2 percent to 12.6 percent).

Conclusion

An unexpected increase in revenues in 1998 has virtually ensured that the total federal budget will be balanced for the first time in almost 30 years, and nothing currently visible on the horizon seems to threaten a return to deficits in the near term if policies remain unchanged.

If any of a number of assumptions that CBO has made turn out to be off the mark, however, budget outcomes may be quite different than projected even if there are no changes in policy. For instance, it is possible that the economy will be more robust than expected or that the unexplained revenue effect will grow over time, in which case the budget outlook will be much brighter than CBO currently projects. If instead, CBO's economic projections prove to be just a little too optimistic, surpluses may be much lower than anticipated, while a recession similar to that of the early 1990s may even produce a deficit. Likewise, surpluses may be lower than projected if the factors that produced the unexpected revenues in 1998 fade away quickly.

The budget outlook can improve or deteriorate rapidly, in part because changes in the fiscal position of the government tend to feed on themselves, producing larger changes in the same direction. In the past few years, for example, a virtuous cycle has helped improve the budget outlook. Initial reductions in the deficit have reduced the federal debt below what had been anticipated. That reduction in the debt reduced federal interest costs, which further reduced the deficit, and so on. But a reversal of those changes could initiate a vicious cycle—with increasing debt and increasing interest costs—that could eliminate the projected surpluses. In the face of those uncertainties, the current budget projections represent CBO's estimate of the middle of the range of likely outcomes.

The Economic Outlook

The U.S. economy has performed better in recent years than it has in decades. Since 1994, growth in the economy's productive capacity has been accelerating, and the unemployment rate has dropped to its lowest level since 1970. The underlying rate of inflation has fallen to its lowest level in more than 30 years and has been remarkably stable.

Few analysts predicted such a stunning economic performance. By the same token, however, few analysts today regard such strong growth without accelerating inflation as sustainable. The Congressional Budget Office (CBO) believes that economic growth will slow in the next few years and inflation will rise modestly.

In CBO's forecast, real (inflation-adjusted) gross domestic product (GDP) grows by an average of 2.9 percent from the fourth quarter of 1997 to the fourth quarter of 1998 and by 2.1 percent from 1998 to 1999 (see Table 1-1). The unemployment rate is expected to average 4.6 percent this year and to rise only slightly, to 4.7 percent, next year. Owing to a small 1.4 percent increase in the first half of 1998, the consumer price index (CPI) is expected to grow by only 1.9 percent from the fourth quarter of 1997 to the fourth quarter of 1998, rising to 2.7 percent in 1999. Despite that increase in inflation, interest rates are likely to remain close to their current levels. The three-month Treasury bill rate is forecast at 5.1 percent in 1998 and 5.2 percent in 1999. The 10-year Treasury note rate is forecast to average 5.8 percent in

1998—just above its level at midyear—rising slightly, to 6.1 percent, in 1999.

For the years beyond 1999, CBO considers a range of possibilities for the path of the economy, taking account of the possibility of booms and recessions, and chooses the middle of that range. In CBO's projection for 2000 through 2008, growth of real GDP averages 2.3 percent a year, and CPI inflation averages 2.5 percent a year (see Figure 1-1). The unemployment rate averages 5.7 percent after 2001. Short-term interest rates are assumed to average 4.4 percent after 2001; long-term interest rates stabilize at 5.4 percent.

That outlook represents CBO's judgment of the most likely outcome for the economy, but it is by no means the only possible outcome. For one thing, all forecasts are prone to error—in the past, CBO's forecast errors have been comparable with those of the Administration and the *Blue Chip* consensus of private-sector forecasts (see Appendix A). Moreover, the basic assumptions on which CBO's outlook is conditioned may turn out to be incorrect. For example, the outlook would worsen if the Asian crisis turned out to be more severe than CBO anticipates. Alternatively, the outlook would improve over the near term if the favorable conditions that have subdued inflation in recent years remained more effective than CBO expects. Although such outcomes now appear less likely than the realization of CBO's basic assumptions, if those alternatives occurred, they could have a significant impact on the economy.

Table 1-1.
The CBO Forecast for 1998 and 1999

	Actual 1997	Forecast	
		1998	1999
Fourth Quarter to Fourth Quarter (Percentage change)			
Nominal GDP	5.6	4.3	4.2
Real GDP ^a	3.8	2.9	2.1
GDP Price Index ^b	1.7	1.4	2.1
Consumer Price Index ^c	1.9	1.9	2.7
Calendar Year Average (Percent)			
Growth of Real GDP ^a	3.9	3.4	2.2
Unemployment Rate	4.9	4.6	4.7
Three-Month Treasury Bill Rate	5.1	5.1	5.2
Ten-Year Treasury Note Rate	6.4	5.8	6.1

SOURCES: Congressional Budget Office; Department of Commerce, Bureau of Economic Analysis; Department of Labor, Bureau of Labor Statistics; Federal Reserve Board.

- a. Based on chained 1992 dollars.
- b. The GDP price index is virtually the same as the implicit GDP deflator.
- c. The consumer price index for all urban consumers.

The Current State of the Economy

The recent performance of the U.S. economy has been truly exceptional. That performance stems from a combination of favorable factors, some temporary and others more enduring. Sharp declines in the prices of imports and computers have temporarily lowered inflation. Slower growth in the cost of medical care and cost-cutting efforts by U.S. businesses have also temporarily reduced inflationary pressures and boosted corporate profits and stock market values. Good economic policy has contributed to a stable economic environment, which, with the rise in the stock market, has bolstered consumer and business confidence. In addition, a weakening of foreign economies has spurred capital inflows from abroad, lowering U.S. interest rates. High stock market values, low interest

rates, and strong confidence have encouraged businesses to invest in plant and equipment, thus raising the productivity and wages of U.S. workers and the profitability of U.S. firms.

One legacy of the economy's recent performance is slightly faster growth of potential GDP in coming years. Because of the good inflation record, CBO has lowered its estimate of the nonaccelerating inflation rate of unemployment (the unemployment rate that is consistent with stable inflation). The boom in capital spending has significantly increased the growth of the nation's capital stock. That development has raised CBO's estimate of the growth of potential GDP over the next decade.

Nevertheless, the economy is showing many of the signs associated with the late stages of an expansion. Labor markets are stretched tight: since 1993, growth in the number of people employed has ex-

Figure 1-1.
The Economic Forecast and Projection

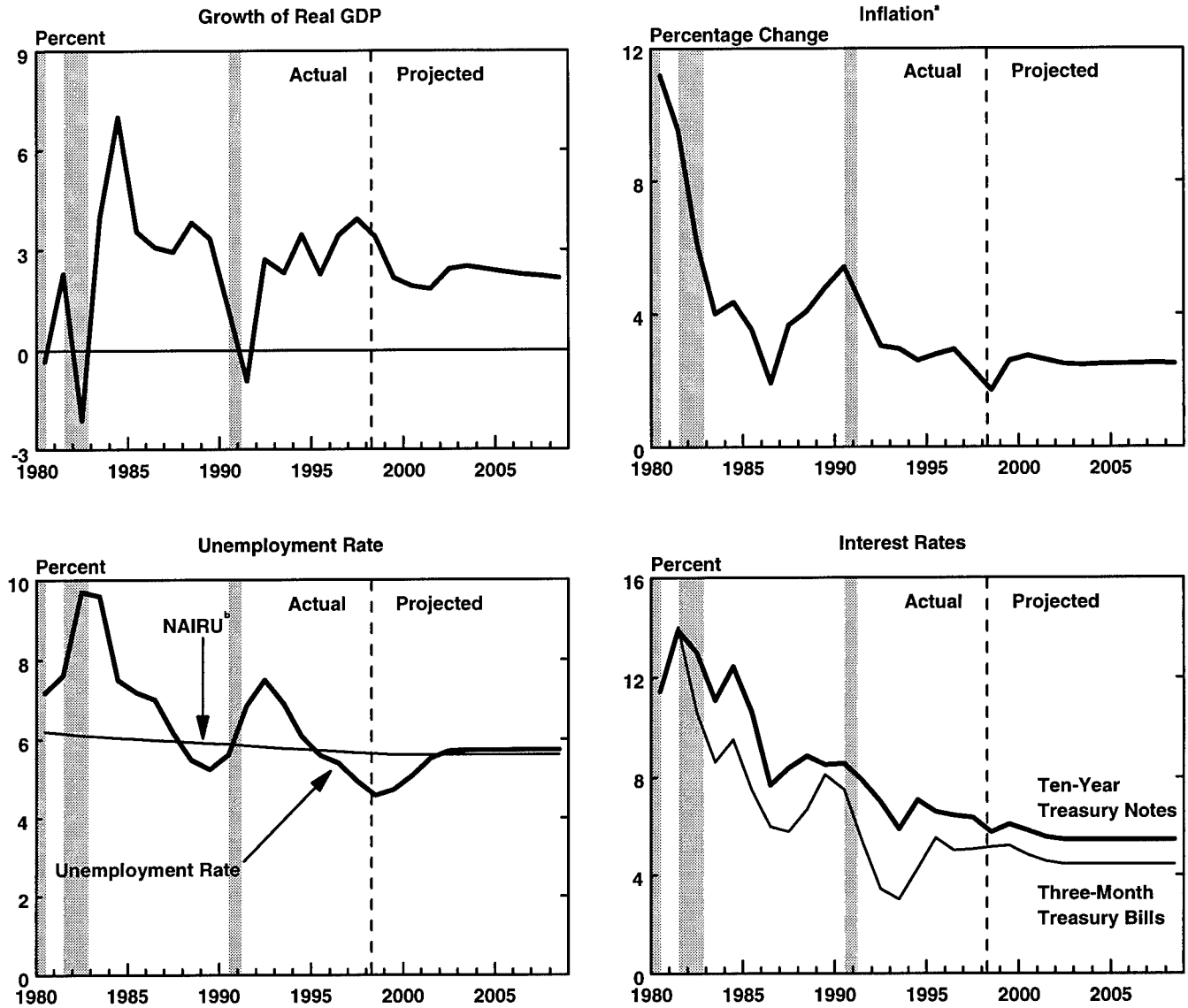

SOURCES: Congressional Budget Office; Department of Labor, Bureau of Labor Statistics; Department of Commerce, Bureau of Economic Analysis; Federal Reserve Board.

NOTE: All data are annual values. Growth rates are year over year.

- a. The consumer price index for all urban consumers. The treatment of home ownership in that index changed in 1983. The inflation series in the figure uses a consistent definition of home ownership throughout.
- b. CBO's estimate of the nonaccelerating inflation rate of unemployment.

ceeded growth in the labor force (the number of people working or actively seeking work). The unemployment rate is well into the range associated with a rise in inflation, and as a result, wage growth has accelerated. Meanwhile, skyrocketing equity prices have left

stock market values at record levels, and declining residential vacancy rates have led to an upturn in property values and rental rates. In addition, credit has become increasingly available, as evidenced by growth in some measures of the money supply and in

bank lending. Those developments may prevent the economy from performing as well over the next two years as it has recently.

Recent Economic Growth

During the past three years, real GDP has risen at an average rate of 3.7 percent a year—well above the estimated noninflationary potential growth of the economy. However, inflation has not increased. In fact, the underlying rate of CPI inflation hovered at 2.4 percent in the first half of 1998, the same rate that prevailed in 1997 and below the 2.7 percent it posted in 1996. With such low inflation, the Federal Reserve Board has not found it necessary to raise interest rates since 1997, even though the unemployment rate has dropped to 4.5 percent. Moreover, over the past two years, the U.S. budget has moved from a deficit to a substantial surplus, thereby converting a significant drain on national saving into a source of financing for private investment.

Growth in both consumption and investment has contributed to the strength of economic growth during the past three years. Consumption has grown by 3.7 percent a year, substantially faster than disposable personal income; consequently, the personal saving rate has dropped over those years to 0.6 percent. One factor fueling the strength of consumption is an enormous increase in the net worth of households since 1994, largely the result of a 138 percent rise in the stock market since then (see Figure 1-2). The performance of investment has been even more dramatic than that of consumption. Real spending on nonresidential construction has increased only slightly faster than GDP over the past four years, but real investment in equipment has increased much faster (by 13.2 percent a year since 1994), reflecting especially large purchases of computers and communications equipment.

By most measures, the economy has remained strong this year. Quarterly growth of real GDP has been choppy, reflecting the effects of a large swing in inventories and the strike against General Motors. Averaged over the first half of the year, however, real GDP has posted a solid advance, growing by 3.5 percent at an annual rate. Moreover, final sales have accelerated. Real final sales of goods and services grew

by 4.1 percent over the past two quarters, compared with 3.5 percent in 1997. Real domestic purchases have accelerated even more sharply this year, growing at a 5.8 percent pace during the first half of 1998.

So far, the major drag on growth in demand has been the worsening of the trade balance. But domestic demand will probably also have to slow down to restore a balance between demand and supply. The necessary adjustment could be quite painless—the sought-for “soft landing” might occur without much action by the Federal Reserve. That could turn out not to be the case, but it is difficult now to pinpoint what, if anything, might go wrong.

The Labor Market and Wage Costs

Since 1993, the number of people employed has grown 0.5 percentage points faster, on average, than the labor force, and the unemployment rate has fallen below the nonaccelerating inflation rate of unemployment, or NAIRU. The pressure on the supply of labor has resulted in some increases in real wages. But the effects of those wage gains on the overall rate of price inflation have been tempered by an acceleration in the growth of productivity, a relatively low rate of capac-

Figure 1-2.
Household Net Worth

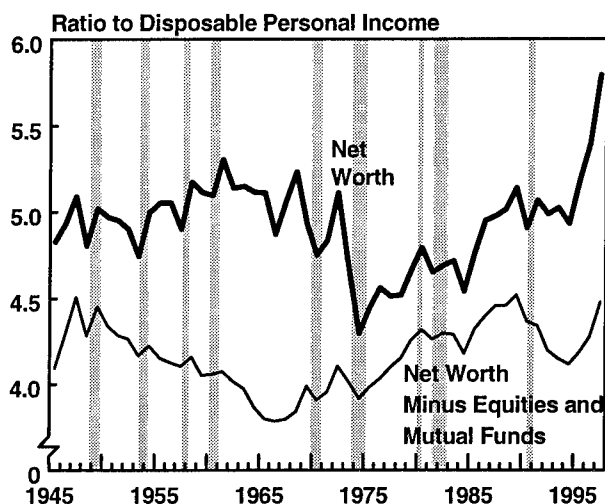

SOURCES: Congressional Budget Office; Department of Commerce, Bureau of Economic Analysis; Federal Reserve Board.

ity utilization, and a spate of special factors that have helped subdue overall inflation. Even so, neither the size of the working-age population nor the rate of labor force participation is likely to increase enough to support the current rate of employment growth without some rise in inflation.

Labor Force Growth. Growth in the labor force is contributing less to the growth of the economy's productive capacity than it used to. From World War II until 1990, the size of the labor force increased by an average of 1.8 percent a year, accounting for a significant share of the estimated growth of potential GDP in that period. That increase reflected both the growth of the working-age population (from natural increase and immigration) and a substantial rise in the percentage of the working-age population that wanted to work. Since 1990, however, annual growth in the labor force has averaged only 1.1 percent.

The entry of new workers accelerated when the baby boomers joined the labor force, but the youngest baby boomers are now 33 and are already experienced workers. The people now entering the labor force for the first time belong to the smaller "baby-bust" generation. That demographic change, combined with an anticipated slowdown in immigration in coming years (compared with the past decade), leads CBO to expect only relatively modest increases in the working-age population.

The labor force participation rate (the labor force as a percentage of the working-age population) also increased before 1990, but that rate is now rising much more slowly. The proportion of men in the labor force drifted downward over a long period, reflecting earlier retirement, lower labor force participation among the less educated as their prospects declined, and more time spent in school. The trend toward earlier retirement among male workers appears to have halted, but the relative returns from greater education and skills continue to increase school enrollments and postpone entry into the labor force. Until about 1990, the falling proportion of working-age men in the labor force was more than offset by the large increase in the proportion of working-age women. (The participation rate for women between the ages of 25 and 54 rose from 40 percent in the 1950s to 77 percent in 1997.) That increase has slowed dramatically since 1990, which is perhaps not surprising given that women's

participation in the labor force is now closer to that of men. During the 1990s, the bulk of the growth in the labor force has come from population growth.¹

With such a slow natural increase in the working-age population, and only a modest increase in labor force participation, the growth of employment has lowered the unemployment rate. It has also drawn some people into jobs who had not reported on surveys that they were looking for work. If employment continues to grow that way in the future, it will probably become increasingly expensive, as employers boost the wages they offer to lure workers into their jobs. Wage pressures are already intensifying—over the first half of this year, the employment cost index (ECI) grew at an average annual rate of 4 percent, 0.5 percentage points more than in 1997. So far, the costs of higher wage growth have been largely offset for employers by increases in productivity growth and declines in the cost of medical insurance. But those offsetting factors may no longer prove sufficient to keep the upward pressure from wages on employers' costs in check over the next two years.

Productivity Growth. The measured trend for growth in labor productivity has consistently been about 1.1 percent since 1973, averaged over various business cycles (see Figure 1-3). That same 1.1 percent trend rate also seems to characterize the growth of productivity since the most recent business-cycle peak in 1990. The behavior of productivity growth has been somewhat unusual in this latest cycle, however. After shooting upward, as expected, early in the recovery, growth in labor productivity slumped from 1993 through 1995, before bouncing back in 1996 and 1997 to grow by 1.9 percent. Some analysts claim that the recent growth in excess of the 1.1 percent trend is an indication that the trend growth of labor productivity has increased. They argue that the economy has entered a new era—that an acceleration in technological change (specifically in information technology), an increase in competitive pressures, and a reduction in government involvement in economies worldwide will cause trend productivity growth to be greater in the future than it was from 1973 to 1995.

1. Changes in the techniques used to collect labor force data have also contributed to the slower growth in the estimated labor force. See A.E. Polivka and S.M. Miller, *The CPS After the Redesign: Refocusing the Economic Lens*, Working Paper No. 269 (Department of Labor, Bureau of Labor Statistics, March 1995).

Figure 1-3.
Labor Productivity

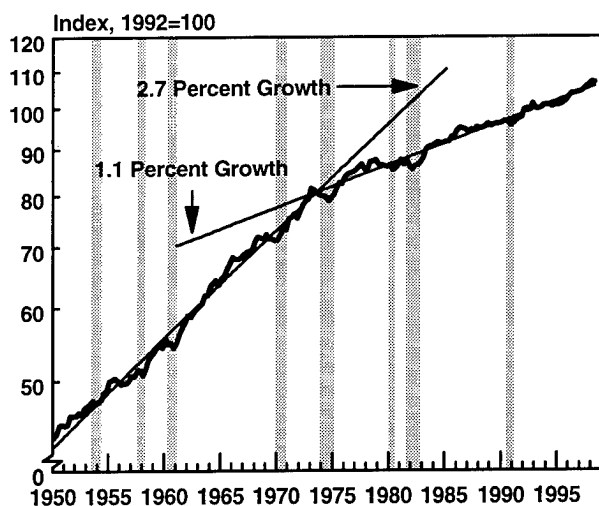

SOURCES: Congressional Budget Office; Department of Labor, Bureau of Labor Statistics.

NOTE: The figure uses a logarithmic scale.

CBO does assume a higher trend growth in labor productivity for future years—but solely because of increases in the growth of the capital stock and changes in the way inflation is measured, not because of the new-era arguments. The capital stock has increased rapidly since 1994, and that growth accounts for much of the rise in labor productivity in recent years. In addition, changes in the way prices are measured for personal consumption expenditures in GDP have raised the growth rate of output in the nonfarm business sector by almost 0.2 percentage points a year in 1995 through 1997.² Although those changes in the measurement of prices boost the growth of real GDP, the growth of nominal GDP is not affected. Those changes also imply that the measures of prices and real output in the past three years of GDP data are not strictly comparable with those of previous years.

2. The revisions of GDP data for 1995 through the present, which were published on July 31, corrected an overstatement of inflation (and a consequent understatement of real growth) that stemmed from the use of CPI data. The CPI data did not properly account for consumers' ability to offset some of the adverse effect of rising prices within certain categories of consumption by substituting less expensive goods within that category. Thus, the true price to consumers for some categories of goods was growing less rapidly than the CPI indicated. Allowing for more substitution reduced the growth of the price index for nonfarm business output by about 0.2 percentage points a year between 1995 and 1997.

Employers' Costs for Medical Care. Employers' payments for medical care are a significant part of the total package of employment costs. In the 1990s, inflation in the cost of health insurance declined rapidly as managed care companies pressured health care providers to keep a lid on their charges and as more of the costs were borne by employees. As a result, overall compensation costs grew less rapidly, increasing profits. Ultimately, however, competition among employers will ensure that lower costs for fringe benefits will mean higher cash wages for workers. Thus, the slowdown in the growth of medical care costs may partially account for the rise in the growth of cash wages that has occurred since 1994.

The reduction in the growth of medical care costs has been dramatic. One measure—the growth of the personal consumption price index for medical care—declined from 8.5 percent in 1989 to 2.3 percent in 1997 (see Figure 1-4). The consumer price index for medical care fell as well. Between 1994 and 1997, when the overall rate of inflation was expected to increase because of intensifying pressures on supply, medical care inflation eased by 1.8 percentage points in the personal consumption price index and by 2 percentage points in the CPI.³

The reduction in the growth of employers' costs has been even more striking. In the 1980s, the total cost of companies' health insurance premiums shot up by as much as 14 percent a year. Employers responded by shifting workers into managed care programs, and enrollment in conventional fee-for-service health plans dropped. (In 1988, about three-fourths of all employees in firms with 200 or more workers were enrolled in conventional plans; a decade later, only 14 percent were.) Competition among managed care plans was aggressive, putting pressure on health care providers to slow price increases and reduce the use of medical services. In addition, more of the cost of

3. The way the CPI measures medical care inflation has changed twice in recent years. Since January 1995, the prices of generic drugs have been matched with the prices of the previously patented drugs that they are copying. And in January 1997, surveys of hospital prices were redesigned to better capture actual transaction prices rather than the list prices paid, because of the increased use of discounts for various health plans. The Bureau of Labor Statistics has not estimated the effect of those changes on the CPI for medical care. But the effect on the growth of the overall CPI is presumably less than 0.1 percentage point, since the current combined relative importance of prescription drugs and hospitals in the overall CPI is less than 3 percent.

Figure 1-4.
Medical Care Inflation

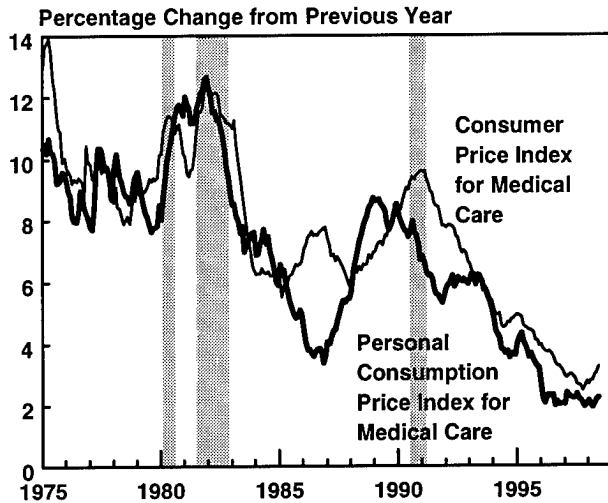

SOURCES: Congressional Budget Office; Department of Labor, Bureau of Labor Statistics; Department of Commerce, Bureau of Economic Analysis.

health care appears to have been shifted from employers to current and retired workers. As a result of those changes, the per-employee cost of medical insurance premiums, which grew by 13 percent in 1989, did not grow at all in 1997 (see Figure 1-5). The drop in the growth of those costs has helped businesses offset the increasing growth of wages, keeping the growth of unit labor costs low. That in turn has helped subdue inflation and strengthen profits.

Recent evidence suggests that the deceleration in medical costs is nearing an end. Inflation in the CPI for medical care has begun to pick up—in the first half of this year, the index increased at an average annual rate of 3.7 percent, up nearly 1 percentage point from the 1997 rate. Moreover, as managed care plans become the dominant form of health care coverage, the ability to further reduce growth in medical costs by shifting workers to such plans becomes more limited.

The NAIRU. CBO bases its estimate of the nonaccelerating inflation rate of unemployment on an analysis of the relationship between unemployment and inflation using a model known as the Phillips curve. In that model, inflation tends to rise if the unemployment rate is below the NAIRU and tends to fall if the rate is above the NAIRU.

The unemployment rate is now well below most estimates of the NAIRU. Some analysts argue that the fact that inflation has not yet sped up is evidence that the NAIRU is temporarily very low, perhaps as low as the unemployment rate (although few would suggest that such a low NAIRU could persist). That argument is equivalent to CBO's view, which is that the fortunate concurrence of a strong dollar, low medical care inflation, and falling oil and computer prices has temporarily offset the price pressures coming from the low unemployment rate.

CBO has, however, lowered its estimate of the NAIRU to 5.6 percent from the 5.8 percent used in last January's forecast. That revision stems largely from an update of the econometric equation used to compute the NAIRU. Including more recent data in the equation lowers the estimated NAIRU and moves CBO's estimate closer to the consensus estimate of other economists. That revision, however, does not alter CBO's view that labor markets are extremely tight.

Emerging Pressures on Wage Costs. The fundamental concern about wage costs is that, with little slack remaining in the labor market, they could begin

Figure 1-5.
Benefits per Hour

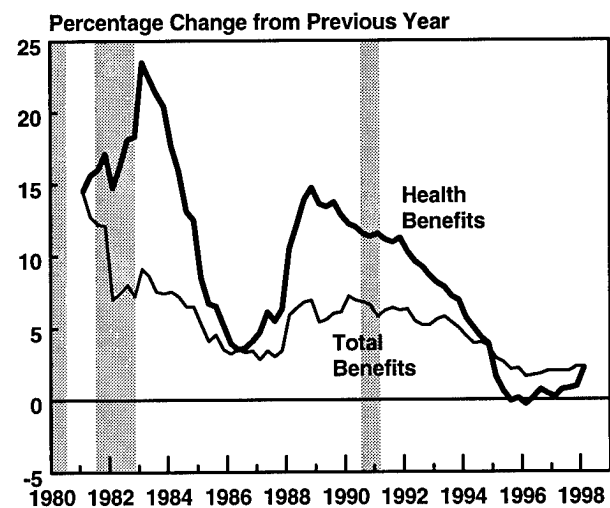

SOURCE: Department of Labor, Bureau of Labor Statistics.

NOTE: These numbers come from the employment cost index for total benefits and for health benefits in private industry.

to accelerate more rapidly. Until recently, the spurt in productivity growth and declining costs of medical care to employers have offset the rising cost of cash wages, protecting profits and preventing higher wages from spilling over into higher prices. Although still growing rapidly, productivity has not accelerated over the past three quarters, allowing accelerating growth in wages and medical costs to catch up. Whether the economy will slow enough to contain the increase in wage costs remains to be seen.

The Boom in Capital Spending

Growth of real business expenditures for plant and equipment has outpaced growth of GDP by more than 6 percentage points since 1993. The supply of capital has increased with demand as businesses have been able to find ready internal and external sources of finance. As a result, capital costs have remained relatively low, and, most important, the current expansion has substantially enhanced the economy's productive capacity.

Capital Spending. Since 1993, real business spending on plant and equipment has increased by more than 9 percent a year. Moreover, the percentage of that investment going to replace worn-out plant and equipment has declined steadily for the past five years. As a result, net investment in plant and equipment has grown by about 25 percent a year since 1993. That four-year performance is stronger than the growth during any other four-year period since the 1960s. Remarkably, the boom in capital spending on plant and equipment has reduced the rate of capacity utilization late in the expansion, when it would have been expected to increase. The boom has also contributed to the recent spurt in productivity growth.

The sources of that boom are not hard to find. The most important one has been the high level of corporate profits, which has boosted internal sources of finance for businesses and given them an incentive to increase capacity by adding to their capital. Corporate profits were already rising rapidly because of the dramatic decline in corporate debt burdens after the 1990-1991 recession (see Figure 1-6). They received further boosts from the lower cost of productive inputs and the decline in employer-paid health insurance

costs since 1994 and from the spurt in productivity in 1996. Only late last year did the growth of corporate profits begin to show signs of faltering, as growth of compensation costs exceeded growth of productivity.

A second, related factor in the capital spending boom has been the low and stable cost of capital for businesses. Increases in stock prices have dramatically lowered the corporate sector's cost of capital. At the same time, the rate of inflation has remained low and remarkably stable (see Figure 1-7). That increased stability not only lowers the risk premiums inherent in the cost of equity and bond finance but also makes the real cost of capital more predictable, thus reducing the "market risk" associated with any capital investment. That is, if investors can be relatively sure that capital costs will fluctuate only slightly, they will be better able than they would in a more turbulent environment to assess, and possibly more willing to undertake, costly and often irreversible multiyear investment projects. The increased stability of capital costs

Figure 1-6.
Corporate Profits, Interest Costs, and
Health Benefit Costs

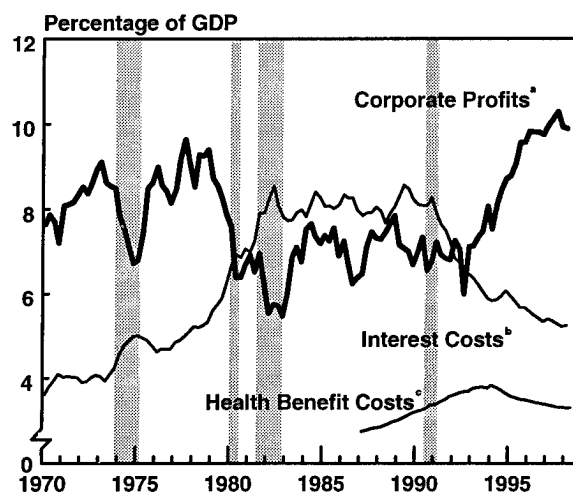

SOURCES: Congressional Budget Office; Department of Commerce, Bureau of Economic Analysis.

- The ratio of economic profits to nominal GDP.
- The ratio of interest paid by businesses to nominal GDP.
- The ratio of employer payments for health insurance to nominal GDP.

Figure 1-7.
Volatility in the Core Rate of CPI Inflation

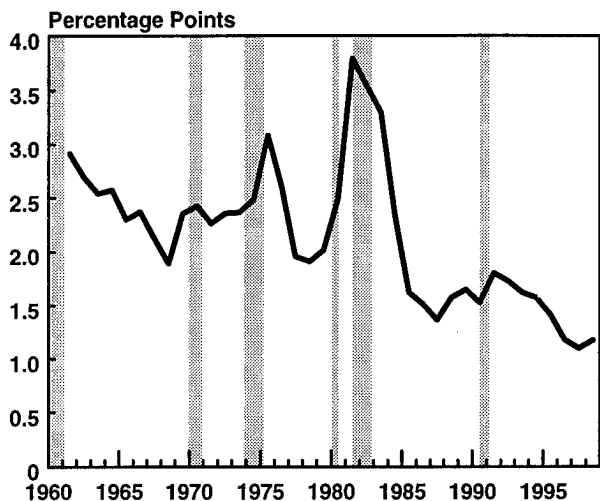

SOURCES: Congressional Budget Office; Department of Labor, Bureau of Labor Statistics.

NOTE: Volatility is measured using the annual averages of monthly estimates of the standard deviation of the underlying rate of inflation in the consumer price index (CPI), conditional on information prior to that month. The technique used for estimating the monthly volatility measures is described in G. William Schwert, "Why Does Stock Market Volatility Change Over Time?" *Journal of Finance*, vol. 44, no. 5 (December 1989), pp. 1115-1153.

has undoubtedly contributed to the endurance of the boom in capital spending.

That boom has also been spurred by astonishing advances in high-tech assets, particularly computers. Adjusted for quality improvements, computer prices have been plummeting, which enables businesses to buy a great deal of computing power for relatively little outlay. Other high-tech goods, such as computer peripherals and communications equipment, have also seen price declines and rapid real increases in demand, although not quite as dramatic as those for computers.

The Supply of Financial Capital. Aside from higher corporate profits, the increase in demand for capital goods has been financed from sources that would not have been expected just a few years ago. Personal saving has remained remarkably low through the current expansion, limiting that source of capital finance. But a sharp reversal of the federal government's budget deficit and increased inflows of capital from abroad have increased the sources of funds available for investment. In the absence of those sources, the

rapid acceleration of demand for capital in recent years might have increased the cost of capital more quickly than has occurred.

Personal saving, generally a major source of financing for investment, has not contributed as much as might be expected to the growth in the supply of capital. As a percentage of disposable personal income, the personal saving rate hit an all-time low of 0.6 percent in the second quarter of 1998 (see Figure 1-8). Much of that decline can be attributed to the strength of the stock market. If people perceive themselves to be getting richer through the market's rise, they are more willing to incur debt, which reduces overall personal saving. In addition, the way the national income and product accounts (NIPAs) measure personal income does not include capital gains distributed to households. As a result, when capital gains distributions are high, people may base their consumption decisions on a substantially greater income than is measured in the NIPAs, and the saving rate is likely to decline.

A budget deficit of \$107 billion in 1996 has given way to an anticipated surplus of \$63 billion this year. Does the emergence of that surplus simply reflect the temporary strength of an economy at the top of a business cycle, or is it a more permanent improve-

Figure 1-8.
The Personal Saving Rate

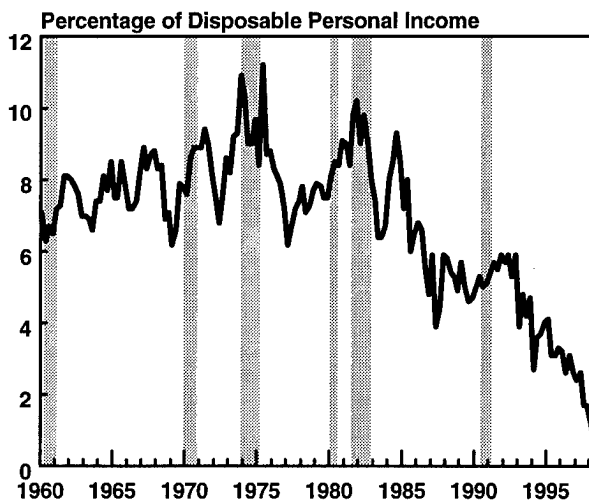

SOURCES: Congressional Budget Office; Department of Commerce, Bureau of Economic Analysis.

ment? The tax increases and restraints on spending imposed in recent budget agreements have played a role in improving the budgetary picture, but they are insufficient to explain the extent of that improvement. Sorting out the temporary influences of the business cycle is particularly difficult because the reasons for the recent surge in revenues are not completely understood (see Chapter 3).

Although the source of the budgetary improvement is still somewhat mysterious, its impact on national saving is less so. Eliminating the deficit has lowered the federal government's borrowing requirement, thus freeing up loanable funds for the boom in

domestic investment and offsetting a substantial part of the shortfall in personal saving.

Capital inflows from investors overseas have provided the other major source of financing to meet the increased demand for domestic investment. Foreign investors have increasingly sought the security of U.S. capital markets, particularly over the past year, as Asia's troubles have mounted and Japan's economy has sunk further into its apparently intractable difficulties (see Box 1-1). Capital inflows provided 8 percent of the funds for U.S. investment in 1997 and 10 percent in the first half of 1998.

Box 1-1.

The Cloud of the Asian Crisis Lingers On

More than a year has passed since the economic crisis erupted in Asia, but the region's woes are far from over. Demand and activity in much of Asia continue to weaken. Consumption is falling and unemployment rising, not only in Indonesia, South Korea, and Thailand, but also, to a lesser extent, in Hong Kong, Malaysia, China, and Japan. Even the economies of Taiwan and Singapore have been dragged down by the weakness in the rest of the region.

The hardest-hit country has been Indonesia, where gross domestic product (GDP) is projected to plummet by more than 10 percent this year. That painful adjustment has sparked political unrest, which led to the toppling of the longtime ruler, General Suharto. The situation is less dire in South Korea and Thailand, but the road to recovery in those countries is still a rocky one. Malaysia and Hong Kong are now in recession as well; and although China is not, its growth has slowed markedly. China is also crippled by the huge volume of bad loans in its banking system and is threatened by rising unemployment, deflationary pressure, the collapse of competing currencies, and the fallout from a massive restructuring of state enterprises.

How the postcrisis adjustment unfolds in Asia will depend to a significant extent on developments in the Japanese economy and currency. News from Japan, however, does not bode well for a speedy recovery in the region.

Japan is now mired in its most severe recession since the end of World War II. Real GDP fell at an annual rate of 5.3 percent in the first quarter of 1998, after contracting 1.5 percent in the previous quarter. The jobless rate hit a postwar peak of 4.1 percent in May. Bankruptcies are also at an all-time high. Worries about jobs and the fragility of financial institutions have made consumers unwilling to spend. Businesses, struggling under a mountain of debt and excess capacity, are slashing investment, and exports to the rest of Asia are falling. The massive volume of bad loans in the banking system (probably far larger than the official estimate of 77 trillion yen, or 15 percent of GDP) has resulted in a credit crunch, even though the Bank of Japan has kept the official discount rate at just 0.5 percent since September 1995. Commercial banks not only have been unwilling to lend but also have begun raising effective rates on the loans they do make to compensate for credit risk.

Unless something is done soon to spur demand in Japan, the rise in effective lending rates in the midst of price deflation could deepen the recession even further. In the spring, the government passed a record fiscal stimulus package (worth 16 trillion yen, about 3 percent of GDP) for fiscal year 1998, including a tax cut of about 4 trillion yen (0.8 percent of GDP) over the 1998-1999 period. It also earmarked 30 trillion yen (about \$215 billion) for protecting depositors and stabilizing the financial system and pledged to create a "bridge-bank" scheme that would

Although reliance on foreigners to supply funds for investment helps the U.S. economy avoid painful adjustments over the short run, it has a long-run drawback. What the United States borrows from foreigners must eventually be repaid, so the additional investment made possible by the capital inflows does not add significantly to the future well-being of U.S. residents. Nor does it provide as fruitful a base for U.S. taxation as would investment based on domestic saving, since incomes to foreigners largely escape U.S. taxes.

Financial Markets and Monetary Policy

Low and stable price inflation—in concert with soaring stock prices, greater capital inflows, and cautious monetary policy—has contributed to a stable economic environment that has bolstered consumer and business confidence. That favorable environment has been called a "virtuous cycle" because in some ways it feeds on itself, at least for a time. As optimistic valuations in the stock market are rationalized by strong

Box 1-1. Continued

resolve the problems of failing banks and maintain lending to financially healthy borrowers. More recently, Japan's new government has proposed other stimulative measures, hoping to restore enough consumer and corporate confidence to trigger a recovery.

Reflecting Japan's desperate economic condition, the yen has depreciated sharply relative to the dollar. It is likely to weaken further if more capital leaves the country in search of higher rates of return abroad. A weaker yen could prove disastrous for the other Asian countries struggling to recover from their slumps, even though it may be what Japan needs to help reflate its own economy.

As the fallout of the Asian crisis increasingly hits the rest of the world, the outlook for global growth is likely to be precarious for the rest of 1998. Some key emerging economies that depend heavily on foreign capital—such as Brazil, Mexico, and Russia—will be especially challenged. Mexico has already tightened money-market conditions and announced three sets of budget cuts in response to the inflation dangers posed by a weakening currency and falling export revenues. For its part, Russia has been struggling desperately to protect the ailing ruble by raising interest rates to unsustainable levels.

Partly because of the spillover effect of the Asian crisis, growth in North America is expected to slow noticeably. Real economic activity in Canada and Mexico is showing signs of slowing to more sustainable rates in 1998 after above-trend growth in 1997.

Solid employment growth will continue to bolster consumer spending in both countries, but their exports to the United States will be further squeezed by cheaper Asian imports. The recent strike against General Motors and the resulting two-month shutdown of GM assembly operations may have dealt an additional setback to manufacturing output in Mexico and Canada.

Fortunately, low inflation in Europe and the United States gives policymakers there some scope to be less restraining. And the fact that business cycles around the world are not synchronized right now will continue to help stabilize the global economy.

Domestic demand in Europe is unmistakably picking up, even though the pace of improvement varies among sectors and countries. European exporters are experiencing a sharp slowdown in their sales to Asia, but that drag has not crimped the momentum of growth. The economic upturn in Europe is being fueled by low real interest rates, competitive currencies, and the end of fiscal tightening. Moreover, years of weak spending in the region have left considerable pent-up demand for durable goods. In addition, unemployment has been falling almost everywhere in Europe. That powerful combination should carry the upturn well beyond this year. And next year, the region's fiscal policy may even become stimulative, despite urgings by the newly established European Central Bank for member countries to further reduce their structural budget deficits.

corporate earnings, investment is stimulated, confidence is fueled, and those repercussions lead to even higher valuations of future corporate performance. Moreover, soaring confidence has made foreigners more willing to invest in dollar-denominated assets, thereby raising the U.S. dollar and helping to ease inflationary pressures.

The abundance of credit and favorable terms in financial markets have further reinforced the virtuous cycle. With the reduction in the federal demand for credit, banks and other lenders have redeployed their loanable funds aggressively toward private-sector borrowers; spurred by low interest rates and a strong stock market, the demand for credit has responded vigorously. The boost in lending has been reflected in accelerated growth of the measures of the money supply known as M2 and M3—and has not gone unnoticed by the Federal Reserve. Although the central bank does not target those money measures officially, it does establish benchmark ranges for them, and the growth rates of M2 and M3 have exceeded the upper limits of their respective ranges since the middle of 1997. In its midyear report to the Congress, the Federal Reserve recognized the possibility that M2 and M3 could be growing too fast to be consistent with low inflation.⁴

The Federal Reserve has, however, focused on maintaining the federal funds rate at a level it perceives to be consistent with the objectives of low inflation and sustainable long-term growth. By that measure, monetary policy has been exceptionally steady. The federal funds rate has not changed since it was raised slightly—by 25 basis points (or 0.25 percentage points) to 5.5 percent—in March 1997. The success of Federal Reserve policy, along with the decline in federal borrowing, has undoubtedly helped reduce expectations of inflation. As a result, long-term interest rates, which are most affected by those expectations, have fallen substantially over the past year. With other short-term rates held steady by the unchanged federal funds rate, the spread between the rates on 10-year Treasury notes and three-month Treasury bills has narrowed, suggesting that investors expect infla-

tion to remain steady and relatively low for the foreseeable future. Barring such shocks as a dramatic worsening of the Asian crisis or a sudden collapse in U.S. stock prices, the Federal Reserve is expected to raise short-term rates only slightly through the near term.

Favorable Price Developments

Three positive developments in the area of prices have—independently of each other—made it possible for the economy to post rapid noninflationary growth rates even as labor markets have tightened over the past four years. First, the appreciation of the U.S. dollar and a corresponding decline in import prices have opened up low-cost sources of supply to U.S. producers, thereby keeping the costs of basic and semimanufactured inputs low in this country. Second, an acceleration in the decline of computer prices has dampened inflationary pressures over the past several years. Third, the lower rate of increase in medical care costs, already mentioned as a factor holding down employers' costs, has had a direct impact on prices. Taken together, those developments have probably lowered the overall rate of inflation in the GDP price index by more than a percentage point per year since 1994.

Reduced Import Prices. Since mid-1995, the dollar prices of merchandise imports other than petroleum and computers have fallen at an average rate of 2.9 percent a year. During the same period, the overall price of imported goods and services fell at an average annual rate of 4.0 percent, the sharpest sustained decline since the 1950s.

The decline in import prices was well timed. Just as the productive capacity of the U.S. economy was beginning to be stretched thin, world economies weakened, thus strengthening the relative position of the United States and causing the value of the dollar to rise against other currencies. Early on, the dollar rose because the Canadian and European economies weakened and uncertainties emerged about the future European single currency. In 1997, just as those countries began to recover more briskly, the Asian crisis burst on the scene, further propelling the dollar's ascent (see Figure 1-9). A strong dollar helps lower the cost of foreign supplies in the United States.

4. Board of Governors of the Federal Reserve System, *Monetary Policy Report to the Congress Pursuant to the Full Employment and Balanced Growth Act of 1978* (July 21, 1998).

Weak worldwide demand also kept commodity prices down precisely at the time that U.S. demand was accelerating. Commodity prices have fallen at an average annual rate of 2.5 percent since mid-1995. That decline has depressed domestic commodity-producing sectors such as agriculture, but it has proved to be a bonus for U.S. manufacturers.

An additional disinflationary impulse arrived in early 1997 when oil prices began to fall. Since then, the price of imported crude oil has dropped from more than \$20 per barrel to less than \$13 (see Figure 1-10). That decline appears to reflect both demand and supply factors. On the demand side, the weakness in Asian economies has lessened their demand for oil. On the supply side, the United Nations relaxed its sanctions on Iraqi oil production in 1997 and further increased Iraq's quota for 1998. Moreover, improved techniques for deep-sea petroleum extraction have lowered production costs per barrel for many oil producers.

Figure 1-9.
The U.S. Dollar Exchange Rate and Import Price Inflation

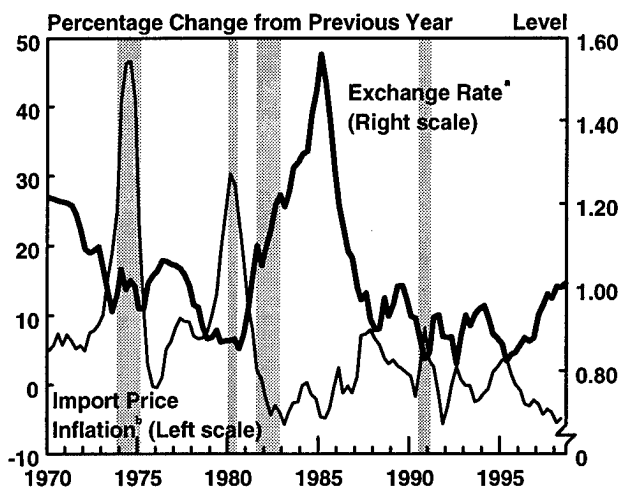

SOURCES: Congressional Budget Office; Department of Commerce, Bureau of Economic Analysis; Federal Reserve Board.

- a. A trade-weighted measure of the exchange value of the U.S. dollar relative to the currencies of the G-10 nations.
- b. The rate of change in the chain-weighted price index for imports taken from the national product accounts.

Figure 1-10.
Commodity and Crude Oil Prices

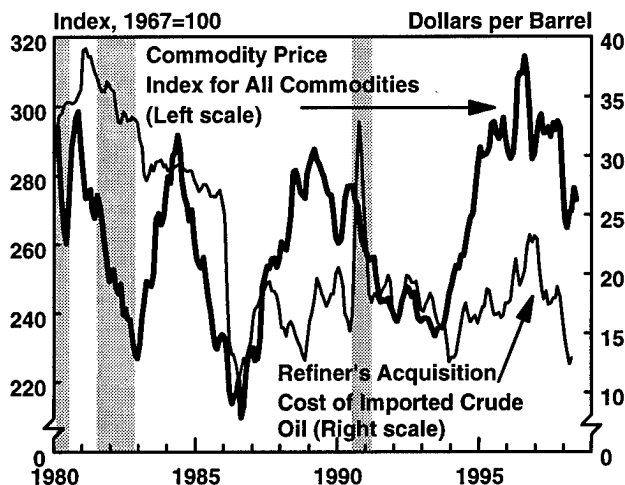

SOURCES: Congressional Budget Office; Knight-Ridder Financial.

Accelerated Decline in Computer Prices. Already on the decline for more than a decade, computer prices began to plunge at a faster rate in 1995, further lowering the overall rate of inflation. Throughout the 1980s and into the early 1990s, the extraordinarily rapid pace of technological innovation lowered quality-adjusted computer prices at double-digit rates. Between 1983 and 1994, for example, the prices of computers exported or sold to domestic businesses declined by approximately 13 percent a year, and the prices of those sold to households fell by more than 15 percent. Since 1995, those prices have plummeted even faster, dropping at an average annual rate of about 23 percent and 30 percent, respectively. CBO estimates that the accelerated decline in computer prices has lowered the overall rate of GDP price inflation by 0.2 percentage points a year since 1995.

The fundamental reason for declining computer prices is the technological innovation that lets manufacturers squeeze ever more onto a computer chip, vastly increasing its power and speed in relation to its cost. However, excess production capacity among manufacturers of memory chips also contributed to a 46 percent decline in the price of those chips in 1996 (see Figure 1-11). The market for memory chips is highly competitive, and the industry has undergone periodic episodes of overcapacity and undercapacity. Currently, the chip industry has excess capacity

Figure 1-11.
Changes in the Prices of Key
Computer Components

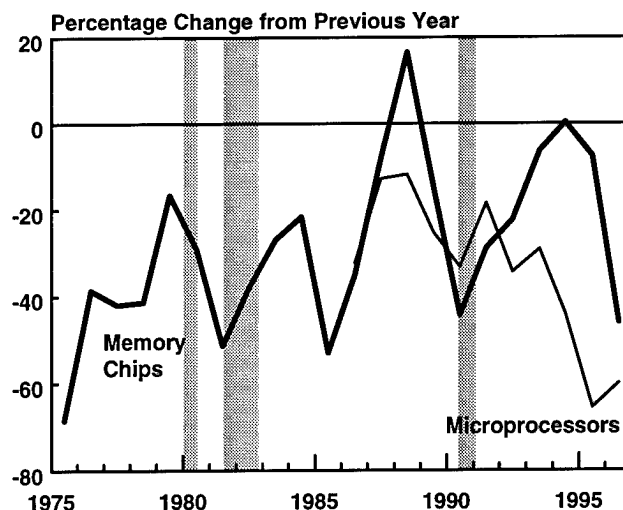

SOURCES: Congressional Budget Office; Department of Commerce, Bureau of Economic Analysis.

(which depresses prices), but that situation is not likely to persist.

Intensified competition among suppliers of microprocessors has depressed their prices by more than 60 percent a year since 1995. That reduction is also likely to be a one-time occurrence, as competition pushes prices down to the levels that are technologically feasible. But determining whether the increased competition has reached those levels is difficult.

Deceleration in Medical Costs. The reduction in inflation for medical care costs has reduced overall inflation. Its biggest impact is in the NIPA price measures: the GDP price index and the personal consumption price index. Medical care expenditures make up more than 12 percent of GDP and about 15 percent of personal consumption; changes in prices for medical care, therefore, have a large direct weight on those overall measures. The deceleration in the cost of medical care has lowered the rate of inflation in the GDP price index by an average of 0.2 percentage points a year since 1994. That reduction reflects the impact on employers' costs for medical insurance, government costs, and employees' out-of-pocket and uncovered expenses.

Effects on the overall CPI have been smaller, however, in part because they reflect only out-of-pocket costs. (The relative importance of medical costs was about 7 percent before the January 1998 rebenchmarking of the CPI and is now about 5 percent.) In addition, the CPI measures of medical care inflation themselves declined by less than the NIPA measures.⁵ As a result, the impact of the decline in medical costs on CPI inflation has been an average reduction of 0.1 percentage point a year since 1995.

Signs of Inflationary Pressures

To varying degrees, each of those favorable price developments is showing signs of dissipating. Moreover, growth in productivity is not likely to accelerate further. As those mitigating factors run their course, the economy will be more vulnerable than in recent years to the growing labor-market pressures that threaten to increase the overall rate of inflation.

By their nature, none of the favorable price developments of the past few years could be expected to subdue overall inflation indefinitely. Medical care inflation is already showing signs of increasing. Moreover, the dollar will not appreciate forever—eventually, the rising trade deficit will overwhelm the factors pushing the dollar up. In fact, the dollar may now be slowing its rate of appreciation. Over the first half of 1998, a measure of the dollar's exchange value relative to the currencies of the G-10 countries rose at an annual rate of 5.9 percent, compared with 10.3 percent in 1997. Even if the dollar had already stopped rising, however, the lagged effects of its recent appreciation would keep import prices declining, albeit at a diminishing rate, probably through this year and the next.

The prognosis for the accelerated deflation in computer prices is harder to judge—projecting the rate of future declines in those prices is at least as difficult as predicting the technological advances and competi-

5. The CPI and the personal consumption price index use different measures of medical care inflation. Since the mid-1990s, the personal consumption price index for the bulk of medical care expenditures has been based on the producer price measures, which use different survey techniques than the CPI and which include prices that the government pays for Medicare and Medicaid patients.

tive pressures that might spawn them. Preliminary data for the first half of this year suggest a more moderate rate of decline than was the case in recent years, but it is really too soon to be sure.

Without those factors, the economy is likely to show clearer signs of overheating. Labor markets are now extremely tight. The unemployment rate is lower than it has been since early 1970, and it has been well within the inflationary range since mid-1996. Wage pressures are intensifying: growth of the ECI for private wages and salaries accelerated to a 4 percent annual rate during the first half of 1998. Rising unit labor costs—the result of stronger growth in wages and benefits without any further acceleration in productivity growth—increase pressure on profits and, ultimately, on product prices.

The Economic Forecast for 1998 and 1999

CBO believes that the stage is set for a modest slowing in the growth of real GDP and slight increases in inflation and interest rates (see Tables 1-2 and 1-3). However, the economy has considerable momentum and is unlikely to weaken severely in the near term. Because consumption will probably remain strong for a few more quarters, real GDP growth for the rest of 1998 and early 1999 is likely to ease only slightly from its recent pace. But the worsening trade deficit, rising inflation, and weaker profit growth this year will undermine GDP growth and cause a small rise in interest rates and slower investment growth. Those changes, in turn, are likely to slow the growth of employment and consumption by the middle of next year.

Taxable Incomes

The share of GDP accounted for by wage and salary disbursements is expected to rise this year and remain basically unchanged next year. That slight rise reflects the pressure of tight labor markets on labor compensation. The unemployment rate has dropped about a percentage point since the middle of 1996, and the growth in wages has picked up as the unemploy-

ment rate has fallen (see Figure 1-12). CBO estimates that the point at which upward wage pressures build because of labor-market tightness is an unemployment rate of about 5.6 percent; the recent pickup in wage growth supports that view.

After a spectacular rise between early 1993 and 1997, corporate profits as a share of GDP are expected to fall in 1998 and 1999. Profits have been squeezed recently between higher labor costs and companies' efforts to avoid raising prices in the face of strong competition at home and abroad.

Unit labor costs did not accelerate as much as wages during 1996 and 1997, however, since labor productivity growth also increased and growth in the benefits component of labor compensation eased. But neither a resurgence in productivity nor a weakness in benefits is likely to keep profits from being affected by increasing wages in the near future. Rising benefits

Figure 1-12.
Tightness in the Labor Market and Wage Growth

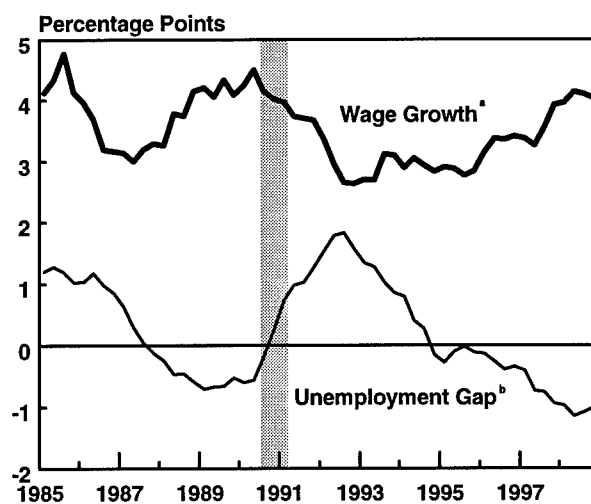

SOURCES: Congressional Budget Office; Department of Labor, Bureau of Labor Statistics.

- Percentage change from previous year in the employment cost index.
- The difference between the unemployment rate and CBO's estimate of the nonaccelerating inflation rate of unemployment (NAIRU). A negative value for the unemployment gap indicates that an acceleration in inflation is more likely than not.

Table 1-2.
The CBO Economic Projection for Calendar Years 1998-2008

	Actual 1997	Forecast		Projected								
		1998	1999	2000	2001	2002	2003	2004	2005	2006	2007	2008
Nominal GDP (Billions of dollars)	8,111	8,397	8,839	9,204	9,572	10,008	10,475	10,955	11,446	11,950	12,473	13,015
Nominal GDP (Percentage change)	5.9	4.9	4.2	4.1	4.0	4.6	4.7	4.6	4.5	4.4	4.4	4.3
Real GDP ^a (Percentage change)	3.9	3.6	2.2	1.9	1.8	2.4	2.5	2.4	2.3	2.3	2.2	2.2
GDP Price Index ^b (Percentage change)	1.9	1.3	2.0	2.2	2.1	2.1	2.1	2.1	2.1	2.1	2.1	2.1
Consumer Price Index ^c (Percentage change)	2.3	1.7	2.6	2.7	2.6	2.5	2.5	2.5	2.5	2.5	2.5	2.5
Unemployment Rate (Percent)	4.9	4.6	4.7	5.1	5.5	5.7	5.7	5.7	5.7	5.7	5.7	5.7
Three-Month Treasury Bill Rate (Percent)	5.1	5.1	5.2	4.8	4.6	4.4	4.4	4.4	4.4	4.4	4.4	4.4
Ten-Year Treasury Note Rate (Percent)	6.4	5.7	6.1	5.8	5.6	5.4	5.4	5.4	5.4	5.4	5.4	5.4
Tax Bases (Billions of dollars)												
Corporate profits ^d	818	817	831	845	841	861	892	927	960	997	1,038	1,083
Wage and salary disbursements	3,890	4,082	4,311	4,487	4,667	4,877	5,101	5,332	5,570	5,814	6,069	6,333
Other taxable income	1,717	1,753	1,841	1,887	1,936	2,000	2,072	2,147	2,221	2,299	2,380	2,465
Tax Bases (Percentage of GDP)												
Corporate profits ^d	10.1	9.7	9.4	9.2	8.8	8.6	8.5	8.5	8.4	8.3	8.3	8.3
Wage and salary disbursements	48.0	48.6	48.8	48.7	48.8	48.7	48.7	48.7	48.7	48.7	48.7	48.7
Other taxable income	21.2	20.9	20.8	20.5	20.2	20.0	19.8	19.6	19.4	19.2	19.1	18.9

SOURCES: Congressional Budget Office; Department of Commerce, Bureau of Economic Analysis; Department of Labor, Bureau of Labor Statistics; Federal Reserve Board.

a. Based on chained 1992 dollars.

b. The GDP price index is virtually the same as the implicit GDP deflator.

c. The consumer price index for all urban consumers.

d. Corporate profits are the profits of corporations, adjusted to remove the distortions in depreciation allowances caused by tax rules and to exclude capital gains on inventories.

Table 1-3.
The CBO Economic Projection for Fiscal Years 1998-2008

	Actual 1997	Forecast		Projected								
		1998	1999	2000	2001	2002	2003	2004	2005	2006	2007	2008
Nominal GDP (Billions of dollars)	8,002	8,397	8,748	9,115	9,475	9,894	10,357	10,834	11,322	11,822	12,341	12,878
Nominal GDP (Percentage change)	5.9	4.9	4.2	4.2	4.0	4.4	4.7	4.6	4.5	4.4	4.4	4.4
Real GDP ^a (Percentage change)	4.0	3.6	2.4	2.0	1.8	2.3	2.5	2.4	2.4	2.3	2.2	2.2
GDP Price Index ^b (Percentage change)	1.9	1.3	1.8	2.1	2.1	2.1	2.1	2.1	2.1	2.1	2.1	2.1
Consumer Price Index ^c (Percentage change)	2.6	1.7	2.4	2.8	2.7	2.5	2.5	2.5	2.5	2.5	2.5	2.5
Unemployment Rate (Percent)	5.1	4.6	4.7	5.0	5.4	5.7	5.7	5.7	5.7	5.7	5.7	5.7
Three-Month Treasury Bill Rate (Percent)	5.0	5.1	5.3	4.9	4.6	4.5	4.4	4.4	4.4	4.4	4.4	4.4
Ten-Year Treasury Note Rate (Percent)	6.5	5.7	6.0	5.9	5.6	5.5	5.4	5.4	5.4	5.4	5.4	5.4
Tax Bases (Billions of dollars)												
Corporate profits ^d	803	817	826	844	841	854	884	919	951	988	1,028	1,072
Wage and salary disbursements	3,823	4,082	4,267	4,443	4,619	4,822	5,044	5,274	5,510	5,752	6,004	6,266
Other taxable income	1,703	1,753	1,827	1,876	1,923	1,983	2,054	2,128	2,202	2,279	2,359	2,444
Tax Bases (Percentage of GDP)												
Corporate profits ^d	10.0	9.7	9.4	9.3	8.9	8.6	8.5	8.5	8.4	8.4	8.3	8.3
Wage and salary disbursements	47.8	48.6	48.8	48.7	48.8	48.7	48.7	48.7	48.7	48.7	48.7	48.7
Other taxable income	21.3	20.9	20.9	20.6	20.3	20.0	19.8	19.6	19.5	19.3	19.1	19.0

SOURCES: Congressional Budget Office; Department of Commerce, Bureau of Economic Analysis; Department of Labor, Bureau of Labor Statistics; Federal Reserve Board.

- a. Based on chained 1992 dollars.
- b. The GDP price index is virtually the same as the implicit GDP deflator.
- c. The consumer price index for all urban consumers.
- d. Corporate profits are the profits of corporations, adjusted to remove the distortions in depreciation allowances caused by tax rules and to exclude capital gains on inventories.

are also likely to temper growth in corporate profits. Medical care inflation is already higher in 1998 than in 1997, and growth in employers' costs for medical benefits is likely to pick up soon.

The expected stagnation of profits, however, should have little effect on the growth of the federal tax base, since much of the softness in profits will be replaced by an increase in wage and salary growth. The tax base should grow along with GDP in the short term.

In recent years, the problem of projecting income has been confounded by a sizable discrepancy in the national income and product accounts. The design of the accounts stems from the basic principle that whatever money is spent in the economy as the result of demand for goods and services is, at the same time, received by someone as income. In principle, the sum of all expenditures should equal the sum of all income. Because the Bureau of Economic Analysis uses different sources of data to estimate the expenditure and income sides of the accounts, some discrepancy between total expenditures and total income is inevitable. But since 1997, measures of total income have exceeded those of total expenditures by an average of 0.7 percent of GDP. CBO assumes that the discrepancy (measured relative to GDP) will rise in 1998 and 1999 before declining moderately.

Households

Buoyed by strong employment growth, rising real wages, spectacular gains in wealth, and soaring confidence, households began 1998 with a burst of consumption. Overall real consumption accelerated during the first half of this year, as did all of the broad categories of consumption. Purchases of durable goods posted an especially strong rise.

Although small, short-term movements in households' wealth are unlikely to have appreciable effects on their patterns of consumption, increases like the ones that have occurred steadily for several years are sure to encourage consumers that they can save less out of their disposable income and still meet their long-term saving requirements. Some analysts have estimated that the wealth effect on consumption may

by itself have added about a quarter of a percentage point per year to real GDP in each of the past three years (see Box 1-2).⁶

The housing boom of 1997 has persisted into 1998. Continued growth in household incomes and wealth has combined with low financing costs to keep demand for housing strong. In the first half of 1998, sales of existing homes grew by 18.8 percent, and sales of new homes grew by 20.4 percent. The especially warm winter allowed building to proceed with minimal interruptions. As a result, real residential investment has been increasing at an average annual rate of about 14.4 percent for the past six months.

That pace should slacken somewhat later this year and through 1999 as the economy slows and long-term interest rates begin to inch up. Moreover, lower rates of household formation among the population of prime first-time home buyers (people ages 25 to 34) will blunt housing growth into the medium term.

Businesses

Following a stunning advance in 1997 of about 14 percent, real business investment entered 1998 at an even faster pace. Much (though by no means all) of that acceleration in late 1997 and early 1998 came from a dramatic swelling in business inventories. During that period, equipment investment—which has been the mainstay of the current expansion—grew more quickly while nonresidential construction declined.

Real purchases of business equipment grew by 12.1 percent in 1997, the most since 1984. That growth was fairly broad based, with investments in assets ranging from communications equipment to office furnishings posting banner performances. Leading the advance were computers and peripheral equipment (42.0 percent growth in 1997) and aircraft (35.8 percent growth in 1997).

6. That estimate, which is based on NIPA data from before the most recent revision, possibly understates the wealth effect on consumption because the unrevised data included capital gains distributions—which are strongly associated with increased household wealth and possibly with increased consumption—within the income effect.

The current environment of robust growth in demand, relatively low and unusually stable real interest rates, and soaring returns on corporate equity has been a boon for equipment investment. With profits growing at double-digit rates until recently, businesses have faced few financing constraints during the expansion. Besides investing in physical plant and equipment, corporations have been undertaking mergers and acquisitions with a renewed vigor and engaging in stock repurchases on a relatively large scale.

Business purchases of structures grew by a respectable 7.1 percent in 1997. Taken together with their growth in 1995 and 1996, that marked the strongest three-year advance since 1982. For the most part, nonresidential construction is far less sensitive to the vicissitudes of the business cycle than is equipment investment. Almost half of last year's growth in nonresidential construction came from a 14.0 percent increase in office construction. Much of the rest came from construction of hospitals, schools, and other institutional buildings.

Box 1-2.

The Impact of the Stock Market on the Economy

The sharp increase in corporate stock prices since 1994 has played a significant role in boosting the economy. Between December 1994 and May 1998, the Standard & Poor's 500 stock-price index (a broad gauge of stock prices) more than doubled, rising by almost 144 percent. Of course, the increase in the stock market reflects the good performance of corporate profits and the overall economy during the past three years. But that increase has also spurred the economy because it has boosted personal consumption expenditures (by raising the value of household wealth) and business investment (by lowering the cost of equity finance for businesses). It may also have spurred the economy indirectly by raising consumer and business confidence.

An increase in the value of household wealth increases personal consumption expenditures because the rise in wealth means that consumers do not need to save as much to achieve their saving goals. The decline of the personal saving rate in the past few years may be an indication of that effect. Empirical estimates find that consumer spending increases between 1 cent and 5 cents for every extra dollar of wealth, with the response taking from one to three years to complete. Although that response is not large, the recent increase in wealth was substantial, so the impact on consumer spending has been noticeable. For example, some analysts have estimated that the rise in household wealth has raised gross domestic product (GDP) by 0.25 percentage points a year for the past three years.

An increase in stock values relative to the level of corporate earnings encourages business investment because firms can finance less attractive investment projects yet remain profitable. A decline in the earnings-to-price ratio means that investors are willing to accept a smaller return on their equity investments (perhaps in hopes of realizing spectacular capital gains later). By paying less for funds, firms can invest in lower-returning assets. For the companies in the Standard & Poor's 500 index, the average earnings-to-price ratio (a measure of the return on stocks and the cost of equity finance) fell from 6.7 percent in December 1994 to 3.6 percent in March 1998. That decline, combined with the drop in long-term interest rates, has had a small but positive impact on business investment.

Over the next few years, however, the stock market may not be able to continue spurring the economy. Many analysts believe that the growth of corporate earnings, and hence the growth of stock prices, will slow this year. Some analysts consider stocks overvalued (by at least 20 percent at midyear) and foresee outright declines in prices. Fewer gains, or even sizable declines, in stock prices would probably have only modest effects on the economy in the short term, primarily because such effects are typically spread out over time. Moreover, a modest retreat by the stock market would lessen pressure on the Federal Reserve Board to slow the economy with higher interest rates. But a precipitous drop in stock prices could have a larger-than-expected impact in the near term if consumer and business confidence fell severely.

Growth in inventories outpaced growth in final sales last year but slowed this year. Current indicators suggest that most of the inventory correction may have taken place in the second quarter of 1998. The resolution of the General Motors strike should cause automobile inventories to rise in the immediate future, and inventories of commodities that have accumulated because of the worldwide decline in prices are likely to diminish only gradually over the near term. Even with last year's rapid buildup, however, inventory stocks did not seem to be out of line with estimates of long-term sales (see Figure 1-13).

Foreign Trade

After rising substantially for the past two years, the U.S. trade deficit for goods and services is likely to widen further this year and into next year, mostly as a result of the direct and indirect effects of the Asian economic crisis. By mid-1998, the trade deficit ballooned to \$167 billion, or 2 percent of GDP—the highest it has been in a decade (see Figure 1-14). A strong U.S. economy and declining import prices have actually held down the trade deficit as a share of GDP.

Real exports have stagnated over the past year while the growth of imports has accelerated. U.S. ex-

Figure 1-14.
Trade Deficit

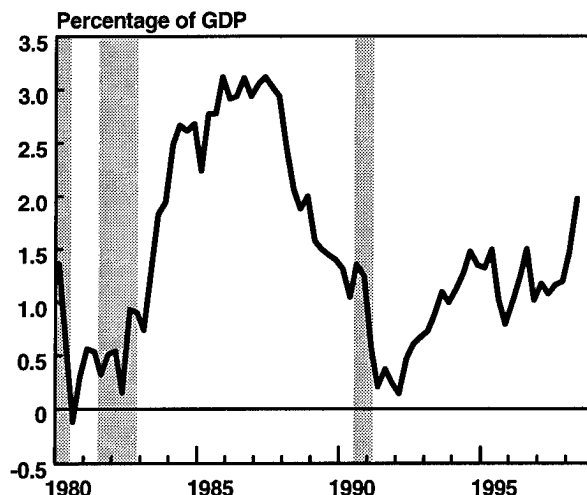

SOURCES: Congressional Budget Office; Department of Commerce, Bureau of Economic Analysis.

Figure 1-13.
Real Inventory Stocks

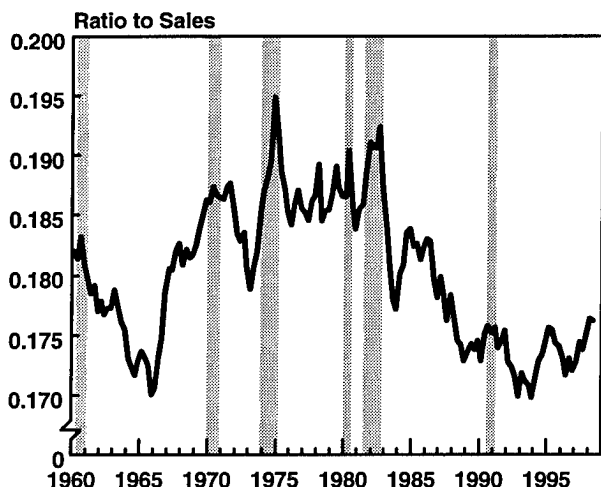

SOURCES: Congressional Budget Office; Department of Commerce, Bureau of Economic Analysis.

ports to Asia have been declining steadily since the second quarter of 1997, and more recently, exports to other regions have begun to slow as well. Among the reasons for that slowdown are that Latin American nations are being forced to curb spending because of anxiety in global financial markets, and oil-exporting countries are reducing their spending in response to lower oil revenues. U.S. exports to Europe are also softening as the strong dollar renders them less competitive than Asian products. Since the dollar is likely to remain strong in a still-jittery global financial environment and the United States remains attractive for investment, the divergent paths of import and export growth will become even more pronounced in the near future. The U.S. trade deficit is thus likely to be an even greater drag on overall economic growth for the rest of this year and at least part of 1999.

The Economic Projection for 2000 Through 2008

The exceptional performance of the U.S. economy over the past several years has improved the economic outlook through 2008. The boom in capital spending by businesses during the current expansion is pro-

jected to continue, though at a slower rate, into the next decade, increasing the nation's stock of capital and raising the growth of potential GDP. Although the temporary factors now holding down inflation will dissipate, the trend in the inflation rate is projected to remain low. Interest rates are also projected to stay low, reflecting the effects of both increased national saving from the elimination of the federal budget deficit and reduced short-term volatility in the inflation rate. Between 1997 and 2008, annual growth of real GDP will average 2.3 percent, CBO projects, somewhat below the 2.5 percent rate projected for potential

GDP during the same period. Unemployment is projected to average 5.4 percent through 2008, and CPI inflation is expected to average 2.5 percent.

Beyond the first two years, CBO's 10-year projection is not a forecast of the ups and downs of the economy but rather an extension of historical trends in the factors that underlie the trend growth of real GDP—factors such as the growth of the labor force, the growth of productivity, the rate of national saving, and the composition of national income.

Table 1-4.
Key Assumptions for the Projection of Potential Output

	Average Annual Growth Rate						CBO Projection, 1997-2008
	1949-1997	1949-1960	1960-1969	1969-1980	1980-1990	1990-1997	
Overall Economy							
Working-Age Population	1.3	0.8	1.4	2.0	1.1	1.0	1.0 ^a
Potential Labor Force	1.7	1.0	1.6	2.7	1.6	1.1	1.0
Potential Labor Force Productivity ^b	1.6	2.7	2.5	0.6	1.0	0.9	1.2
New Price Indexes	n.a.	n.a.	n.a.	n.a.	n.a.	0.1	0.2
Potential Real GDP	3.2	3.8	4.2	3.3	2.6	2.2	2.5
Real GDP	3.3	3.9	4.6	2.8	2.9	2.5	2.3
Nonfarm Business Sector							
Potential Employment	1.8	1.2	1.8	2.7	1.7	1.4	1.1
Potential Hours Worked	1.5	1.0	1.4	2.0	1.6	1.3	1.1
Capital Input	3.7	3.4	4.3	4.1	3.6	2.8	4.1
Potential TFP	1.3	2.0	2.0	1.1	0.5	0.7	0.9
Potential Labor Productivity ^c	1.9	2.7	2.9	1.7	1.0	1.1	1.7
Potential Real Output	3.4	3.8	4.3	3.8	2.7	2.5	2.9

SOURCE: Congressional Budget Office using data from the Department of Labor, Bureau of Labor Statistics, and the Department of Commerce, Bureau of Economic Analysis.

NOTES: The years marking the ends of historical periods (except 1997) are years in which the business cycle peaked.

n.a. = not applicable; TFP = total factor productivity.

- a. Projection for 1997-2006.
- b. Growth in potential output per labor force member.
- c. Growth in potential output per hour (in the nonfarm business sector).

Economic Growth

CBO projects that real GDP will grow somewhat more slowly than potential GDP between 1997 and 2008. The assumption underlying the projection is that actual output will eventually average 0.2 percentage points below potential GDP—a gap equal to the average difference between actual and potential GDP during the postwar period. Using that gap as a target for the projection period is meant to allow for the average likelihood of booms or busts in real GDP during the next 10 years. Since actual GDP was almost 1.5 percent above potential GDP in 1997, it must grow more slowly than potential for a while so as to reach its historical relationship with potential GDP. CBO assumes that the historical gap will be restored in 2002, and afterward, that real GDP will grow at the same rate as potential, on average.

Potential GDP is projected to grow slightly faster than its 2.2 percent rate of the 1990s, but slower than its average rate during the entire postwar period (see Table 1-4 on page 21). That projection stems directly from projections for the supply factors that underlie potential GDP: demographic changes will lead to slower growth in the labor force (relative to both the early 1990s and the entire postwar period), while the capital spending boom of recent years will partly offset the labor force slowdown.

Labor Supply. CBO assumes that the potential, or cyclically adjusted, labor force will grow in tandem with the working-age population, averaging a 1 percent annual advance between 1997 and 2008. That growth is considerably slower than the average for the past 40 years. As noted earlier, the growth of the working-age population, which swelled with the influx of the baby boomers during the 1960s and 1970s, has moderated in recent years. CBO's projection is in line with the trend that has prevailed over the past two decades.⁷

7. CBO's labor force projection also includes an adjustment for the effects of welfare reform. Based on an analysis of caseloads and of legislation passed in 1996, CBO estimated that welfare reform would spur about 600,000 people to enter the labor force who otherwise would not have done so. CBO estimates that about half of that effect has already occurred, so it adds 300,000 people to the projected labor force between mid-1998 and 2008.

Figure 1-15.
Business Fixed Investment

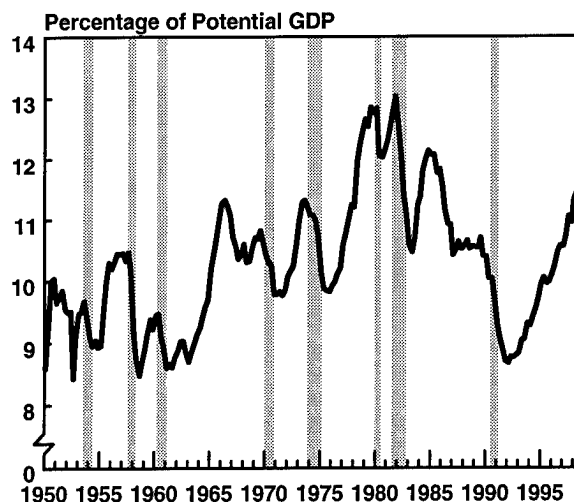

SOURCES: Congressional Budget Office; Department of Commerce, Bureau of Economic Analysis.

NOTE: Business fixed investment represents investment in plant and equipment. It does not include investment in inventories.

The labor force participation rate is also assumed to flatten, stabilizing at about 67 percent of the working-age population (close to its 1997 level). During the 1960s and 1970s, the labor force expanded even more rapidly than the working-age population as ever-increasing numbers of women joined the labor force, pushing up the overall participation rate. CBO follows the projections of the Bureau of Labor Statistics and other private and government forecasters in assuming that the upward climb in participation rates has largely ended.

Capital Input. Business investment in plant and equipment has been extremely strong during the current expansion, leading to a very rapid increase in the stock of productive capital (see Figure 1-15). CBO projects that investment will grow at an average rate of about 5 percent between 1997 and 2008, which translates into an average increase of 4.1 percent in the stock of productive capital during the same period.⁸ That increase is considerably higher than the

8. CBO's measure of capital input is based on the data for real net capital stocks published by the Bureau of Economic Analysis. It is an index that accounts for the fact that different types of capital assets (such as equipment, structures, and inventories) have different marginal productivities.

growth of capital input witnessed during the early 1990s.

Total Factor Productivity. Total factor productivity (TFP) is defined as growth in output beyond what is attributable to growth in labor and capital.⁹ CBO projects that cyclically adjusted total factor productivity will grow at an average rate of 0.9 percent per year through 2008. That rate is higher than the trend rate since the early 1980s solely because of changes in the way prices are measured. The trend in TFP over the past two business cycles has been 0.6 percent, but because the change in price measurement reduces measured inflation for nonfarm business output by about 0.3 percentage points compared with previous years, the trend growth in TFP will be greater by that amount. When combined with the projections for capital input and hours worked, the projection for TFP implies an acceleration in the growth of potential labor productivity, from 1.1 percent during the early 1990s to 1.7 percent during the projection period.

CPI Adjustments. As discussed in previous CBO reports, the projection for economic growth includes a technical adjustment to allow for changes that the Bureau of Labor Statistics has made since 1995 and will make in 1999 in the way it calculates the consumer price index. Those changes are projected to lower the growth of the GDP price index by about 0.2 percentage points a year through 2008. (The technical adjustments are discussed below with CBO's inflation projections.) Those changes in method will not affect nominal GDP, but they imply that the estimate of potential real GDP is 0.2 percentage points a year higher between 1997 and 2008 than it would have been with no revision to the inflation measure.

Unemployment and Inflation

Both the unemployment and inflation rates are projected to rise slightly during the projection period. Slower growth over the next 10 years (that is, growth below potential) implies an increase in unemployment. CBO projects that the unemployment rate will rise

slowly until it reaches a plateau at 5.7 percent, roughly 0.1 percentage point above CBO's estimate of the NAIRU. Nevertheless, the unemployment rate will remain below the level of the NAIRU through 2001, adding to the buildup of inflationary pressure that already exists. At the same time, CBO expects that the supply-side factors that have restrained inflation during the past few years will gradually dissipate, allowing inflation to increase, albeit mildly, over the next 10 years. CBO projects that inflation as measured by the CPI will average 2.5 percent per year after 2001, while inflation in the GDP price index will average 2.1 percent.

CBO's projection for inflation incorporates the host of methodological changes that the Bureau of Labor Statistics is making in its measurement of the CPI.¹⁰ Those changes include rebenchmarking the consumption weights (which was implemented in 1998), as well as switching to geometric aggregation to calculate price changes within major categories and using a more effective sample design (both of which will be implemented in 1999). CBO estimates that the net effect of those changes will be to lower the measured rate of CPI inflation by 0.7 percentage points by 2002. Some of the changes do not affect the GDP price index; growth of the GDP price deflator will be lowered by 0.2 percentage points.

Interest Rates

CBO expects real interest rates to decline gradually over the next decade, with short- and long-term rates each falling about 150 basis points from their 1997 levels. After 2002, the real rate on three-month Treasury bills is projected to average about 2 percent and the 10-year Treasury note rate about 3 percent. Those levels are some 20 to 30 basis points above the levels that prevailed during the late 1950s and early 1960s. That discrepancy reflects CBO's assessment that worldwide supplies of loanable funds are somewhat scarcer today than they were then, largely because of government budget pressures overseas.

9. The more traditional measure of productivity—labor productivity—is defined as the growth in output above what is attributable to growth in total hours worked.

10. For more details about the changes, see Congressional Budget Office, *The Economic and Budget Outlook: Fiscal Years 1999-2008* (January 1998), Box 1-2, pp. 8-9.

Taxable Incomes

Projections of federal revenue are linked closely to projections of national income. However, different components of income are taxed at different rates, and some are not taxed at all. Thus, the distribution of national income among the various components is one of the most important parts of CBO's economic projection. Wage and salary disbursements and corporate profits are of special interest because they are taxed at the highest effective rates.

Together, wage and salary disbursements and corporate profits are projected to decline as a share of GDP by about 1 percentage point between 1997 and 2008. Underlying that projection is a mild increase in the wage and salary share, which is more than offset by a decline in the profit share.

The share of wages and salaries will increase over the 10-year horizon, moving from 48 percent of GDP in 1997 to average 48.7 percent in the years after 1999—roughly equal to the average level from the early 1970s through the mid-1990s. That increase of 0.7 percentage points is quite small compared with the historical variation in the wage and salary share. Between 1946 and 1997, the standard deviation of the share was 1.8 percentage points. Both economic theory and long-run empirical studies have suggested that the share of labor compensation in income is likely to remain fairly constant over long periods.

CBO projects that the profit share of income will decline by 1.8 percentage points between 1997 and 2008, from 10.1 percent to 8.3 percent, thus offsetting about half of its rise between 1986 and 1997. The same economic theories and empirical studies that predict a stable long-run wage share also predict that the capital share of income will remain fairly constant over long periods. Corporate profits are only one part of capital income (others include businesses' interest payments and depreciation), but they are among the most sensitive to the business cycle. Thus, some decline from recent levels is inevitable; CBO expects the profit share to return to its average of the 1970s. Even after that decline, however, profits as a share of GDP will remain well above the level that prevailed during the 1980s—a decade in which soaring debt

burdens severely limited the profitability of corporations.

Uncertainty in the Economic Outlook

The economy's remarkable performance during the past few years has surprised many forecasters. The current economic expansion is more than seven years old—the third longest of the postwar period—yet real GDP and employment have continued to grow rapidly without a resurgence of inflation. Although it is tempting to believe that such a good economic performance will continue, both CBO and the consensus of private forecasters believe that the most likely outcome is an economic slowdown and a rise in inflation. A considerable amount of uncertainty surrounds that outlook, however, and the actual performance of the economy could be somewhat better or much worse.

Changes in CBO's Economic Outlook Since January

Because of strong growth and continued low inflation in the first half of 1998, the forecast for this year and next is a little brighter than CBO predicted last January (see Table 1-5). The expected growth of real GDP is modestly higher, and GDP price inflation lower, for both 1998 and 1999. Those changes largely result from a recent revision of the NIPAs (see Box 1-3). The unemployment rate is also slightly lower for both years, whereas interest rates are lower only for 1998. Various tax bases have also been revised upward slightly for both years.

Beyond 1999, a combination of faster growth of real GDP and slower inflation results in slightly slower projected growth of nominal GDP, and consequently a modestly lower dollar level of GDP in 2008. The faster growth of real GDP arises from continued strong investment by businesses in plant and equipment.

The reduction in the forecast for inflation in 1998 results largely from an unanticipated drop in the price

Table 1-5.
Comparison of CBO's Summer and January 1998 Economic Projections for Calendar Years 1998-2008

	Actual 1997	Forecast		Projected								
		1998	1999	2000	2001	2002	2003	2004	2005	2006	2007	2008
Nominal GDP												
(Billions of dollars)												
Summer 1998	8,111	8,487	8,839	9,204	9,572	10,008	10,475	10,955	11,446	11,950	12,473	13,015
January 1998	8,081	8,461	8,818	9,195	9,605	10,046	10,529	11,038	11,565	12,112	12,684	13,280
Nominal GDP												
(Percentage change)												
Summer 1998	5.9	4.6	4.2	4.1	4.0	4.6	4.7	4.6	4.5	4.4	4.4	4.3
January 1998	5.8	4.7	4.2	4.3	4.5	4.6	4.8	4.8	4.8	4.7	4.7	4.7
Real GDP^a												
(Percentage change)												
Summer 1998	3.9	3.4	2.2	1.9	1.8	2.4	2.5	2.4	2.3	2.3	2.2	2.2
January 1998	3.7	2.7	2.0	1.9	2.0	2.1	2.3	2.3	2.2	2.2	2.2	2.1
GDP Price Index^b												
(Percentage change)												
Summer 1998	1.9	1.2	2.0	2.2	2.1	2.1	2.1	2.1	2.1	2.1	2.1	2.1
January 1998	2.0	2.0	2.2	2.3	2.4	2.4	2.5	2.5	2.5	2.5	2.5	2.5
Consumer Price Index^c												
(Percentage change)												
Summer 1998	2.3	1.7	2.6	2.7	2.6	2.5	2.5	2.5	2.5	2.5	2.5	2.5
January 1998	2.3	2.2	2.5	2.7	2.8	2.8	2.8	2.8	2.8	2.8	2.8	2.8
Unemployment Rate												
(Percent)												
Summer 1998	4.9	4.6	4.7	5.1	5.5	5.7	5.7	5.7	5.7	5.7	5.7	5.7
January 1998	4.9	4.8	5.1	5.4	5.6	5.8	5.9	5.9	5.9	5.9	5.9	5.9
Three-Month Treasury												
Bill Rate (Percent)												
Summer 1998	5.1	5.1	5.2	4.8	4.6	4.4	4.4	4.4	4.4	4.4	4.4	4.4
January 1998	5.1	5.3	5.2	4.8	4.7	4.7	4.7	4.7	4.7	4.7	4.7	4.7
Ten-Year Treasury												
Note Rate (Percent)												
Summer 1998	6.4	5.8	6.1	5.8	5.6	5.4	5.4	5.4	5.4	5.4	5.4	5.4
January 1998	6.4	6.0	6.1	6.0	5.9	5.9	5.9	5.9	5.9	5.9	5.9	5.9
Tax Bases												
(Percentage of GDP)												
Corporate profits ^d												
Summer 1998	10.1	9.6	9.4	9.2	8.8	8.6	8.5	8.5	8.4	8.3	8.3	8.3
January 1998	9.9	9.7	9.2	8.8	8.5	8.3	8.2	8.1	8.0	7.9	7.8	7.7
Wage and salary disbursements												
Summer 1998	48.0	48.7	48.8	48.7	48.8	48.7	48.7	48.7	48.7	48.7	48.7	48.7
January 1998	48.0	48.4	48.5	48.6	48.6	48.6	48.6	48.7	48.8	48.8	48.8	48.8
Other taxable income												
Summer 1998	21.2	20.9	20.8	20.5	20.2	20.0	19.8	19.6	19.4	19.2	19.1	18.9
January 1998	22.1	21.8	21.5	21.2	21.1	20.9	20.7	20.5	20.4	20.2	20.1	20.0

SOURCES: Congressional Budget Office; Department of Commerce, Bureau of Economic Analysis; Department of Labor, Bureau of Labor Statistics; Federal Reserve Board.

- a. Based on chained 1992 dollars.
- b. The GDP price index is virtually the same as the implicit GDP deflator.
- c. The consumer price index for all urban consumers.
- d. Corporate profits are the profits of corporations, adjusted to remove the distortions in depreciation allowances caused by tax rules and to exclude capital gains on inventories.

Box 1-3.**Revision of the National Income and Product Accounts**

In late July, the Bureau of Economic Analysis (BEA) released a comprehensive revision of the national income and product accounts (NIPAs). Such revisions, which usually affect the most recent three years of data, incorporate new and more complete source data and are designed to improve the accuracy of the accounts. Less commonly, the three-year revisions sometimes include new definitions of certain data series or entirely new estimating methods, leading to larger revisions than usual. The recent revision incorporated a number of significant new definitions.

Two changes in particular stand out. First, BEA altered the way the accounts treat capital gains distributions made by mutual fund companies. Capital gains are increases in the value of existing assets rather than income that derives from current production, so they should be excluded from NIPA-based measures of income (since the NIPAs are designed to measure current production and the corresponding income). As a result, BEA changed dividend payments in the national accounts to exclude capital gains distributions by mutual funds. That redefinition sharply reduced the level of dividends in the accounts and increased, by the same amount, the estimate of earnings retained by corporations. The redefinition contributed to a sharp drop in the personal saving rate (down from 3.9 percent to 2.1 percent in 1997) but left the national and private saving rates unaffected.

Second, several of the price deflators, particularly for many categories of personal consumption expenditures (PCE), were changed. Those changes dramatically reduced the measured rate of inflation in the NIPAs since 1995. Revisions to the PCE deflators were prompted by new source data and the use of new types of price indexes that allow for substitution by consumers among different goods and services. As a result, growth in the gross domestic product (GDP) price index, which had averaged 2.1 percent a year between the end of 1994 and early 1998, was revised downward to show an average increase of 1.8 percent during that period. That revision mirrored the downward revision in the growth of the price index for consumer expenditures, which went from an average of 2.0 percent a year during that period to 1.7 percent.

The introduction of the new type of price index caused about half of the downward revision to inflation since 1995. That technical adjustment is similar to ones made by the Bureau of Labor Statistics to reduce bias in the consumer price index. The adjustment permanently lowers the measured rate of inflation and raises real growth by an equal amount, leaving nominal GDP unaffected.

The economic assumptions published in this report largely, though not completely, reflect BEA's revisions. To account for the technical adjustment in the price index, the Congressional Budget Office (CBO) raised the growth rate of potential GDP in recent years and in its projection, reduced the projected growth rate of the GDP price index, and raised the projected growth rate of real GDP compared with the preliminary projection published on July 15. However, the revisions in nominal GDP and in most income categories that matter for projecting revenues were insignificant. The substantial revision in personal dividend income, noted above, simply brings the NIPA measure of dividends closer to what people actually report on their tax returns as dividend income. Thus, the revisions incorporated in CBO's economic assumptions do not have any implications for projections of revenues, outlays, or the budget surplus.

The NIPA revisions do, however, pose a problem that will have to be addressed in future reports. The revisions imply that both real GDP and potential GDP were larger in the first half of 1998 than previously thought, but real GDP was increased by more than potential, so the gap between the two widened. Specifically, GDP was assumed to be about 2.3 percent above potential, but the recent revisions put it about 3.0 percent above CBO's revised estimate of potential GDP. That discrepancy can have one of three ramifications for the economic outlook: the gap might be narrowed or eliminated by more rapid growth of GDP than CBO now assumes; the gap might be narrowed or eliminated if it turns out that potential GDP should be revised upward by more than CBO has already done; or the widened gap might persist, increasing inflation more rapidly than CBO currently forecasts. Additional evidence and analysis will be necessary to determine which of those possible implications of the revisions is most likely.

of oil during the first half of this year. Beyond 1998, the lower inflation projection reflects a revised judgment. In consultation with its Panel of Economic Advisers, CBO concluded that the Federal Reserve was unlikely to tolerate as high an inflation rate over a long period as CBO previously projected. Of course, precisely what level of inflation the central bank would tolerate and could maintain is a guess. In any event, the difference in the inflation projection has only a limited impact on the budget projections described in Chapters 2 and 3 because it affects revenues and outlays in ways that largely offset one another.

The reduction in projected short-term interest rates results from the lower projection of inflation. The lower projected long-term rates result from the assumption that the yield curve will be flatter, partly because of the larger projected federal surpluses.¹¹

Comparison with Other Forecasts and Projections

CBO's current forecast is similar to the forecasts of the *Blue Chip* consensus (the average of the 50 private forecasters surveyed in *Blue Chip Economic Indicators*, published by Capitol Publications), the Administration, and the Federal Reserve Board. All expect slower growth of real GDP and higher inflation by 1999. Beyond 1999, CBO's projections are similar to those of the Administration and the *Blue Chip* consensus, though its projections for interest rates are lower.

The Forecast Through 1999. The differences among the forecasts are generally small (see Table 1-6). CBO expects slower growth for real GDP over the two-year period than either the *Blue Chip* or the Federal Reserve, but slightly faster growth than the Administration. The Administration's forecast was prepared much earlier than CBO's, however, before the data showing extraordinary growth during the first quarter of 1998 were released.

Forecasts for CPI inflation are very similar for 1998 but show greater variation for 1999. CBO's inflation forecast for next year is the highest and the Administration's is the lowest (0.6 percentage points below CBO's). Likewise, the differences in the forecasts for interest rates are trivial for 1998 but more noticeable for 1999, particularly for 10-year Treasury notes. The Administration does not expect an increase in the 10-year rate in 1999, whereas CBO and the *Blue Chip* consensus do.

The differences in the forecasts for unemployment are fairly small. The Administration predicts the highest unemployment rate (5.0 percent by 1999), consistent with the fact that its inflation forecasts are the lowest of the four.

The Projection Beyond 1999. The largest differences between CBO's projection and those of the Administration and the *Blue Chip* consensus appear in interest rates (see Table 1-7). CBO's estimates are lower than those of the other two—almost 0.7 percentage points lower than the *Blue Chip*'s.

The estimates of real GDP growth are quite similar in the three projections, while CBO's estimate of CPI inflation lies between those of the other two. Although CBO's growth rates for real GDP are lower in the first part of the projection period, the average growth of real GDP between 1998 and 2004 (the last year in the *Blue Chip* projection) is the same as the Administration's and slightly lower than the *Blue Chip*'s.

Specific Risks and Alternative Scenarios

The most likely outcome for the economy in the next few years is a soft landing, with slower growth and a mild up-tick in inflation, but that is not the only possible outcome. The economy could fall into a period of slower growth or outright recession originating from a variety of causes. Or it could continue to grow rapidly without a significant rise in inflation if other favorable price shocks occur or if the economy has entered a new era of faster productivity growth.

11. The yield curve is the relationship formed by plotting the yields of otherwise comparable fixed-income securities against their terms of maturity. Typically, yields increase as maturities lengthen. If the rate of that increase becomes smaller, the yield curve is said to have flattened.

Table 1-6.
Comparison of CBO's and Other Economists' Forecasts for 1998 and 1999

	Actual 1997	Forecast	
		1998	1999
Fourth Quarter to Fourth Quarter (Percentage change)			
Nominal GDP			
CBO	5.6	4.3	4.2
<i>Blue Chip</i>	5.6	4.6	4.7
Federal Reserve ^a	5.6	4.5 to 5.0	4.25 to 5.0
Administration	5.6	4.2	4.1
Real GDP ^b			
CBO	3.8	2.9	2.1
<i>Blue Chip</i>	3.7	3.0	2.4
Federal Reserve ^a	3.7	3.0 to 3.25	2.0 to 2.5
Administration	3.7	2.4	2.0
GDP Price Index ^c			
CBO	1.7	1.4	2.1
<i>Blue Chip</i>	1.8	1.6	2.2
Administration	1.8	1.7	2.0
Consumer Price Index ^d			
CBO	1.9	1.9	2.7
<i>Blue Chip</i>	1.9	1.7	2.5
Federal Reserve ^a	1.9	1.75 to 2.0	2.0 to 2.5
Administration	1.9	1.6	2.1
Average Level in the Fourth Quarter (Percent)			
Unemployment Rate			
CBO	4.7	4.6	4.8
<i>Blue Chip</i>	4.7	4.5	4.7
Federal Reserve ^a	4.7	4.25 to 4.5	4.5 to 4.75
Administration	4.7	4.8	5.0
Calendar Year Average (Percent)			
Three-Month Treasury Bill Rate			
CBO	5.1	5.1	5.2
<i>Blue Chip</i>	5.1	5.1	5.2
Administration	5.1	5.0	4.9
Ten-Year Treasury Note Rate			
CBO	6.4	5.8	6.1
<i>Blue Chip</i>	6.4	5.6	5.8
Administration	6.4	5.6	5.6

SOURCES: Congressional Budget Office; Department of Commerce, Bureau of Economic Analysis; Department of Labor, Bureau of Labor Statistics; Capitol Publications, Inc.; Office of Management and Budget; Federal Reserve Board.

- a. The Federal Reserve figures are the ranges—known as the central tendency—that include the majority of the forecasts of members of the Federal Open Market Committee and other Federal Reserve Bank presidents.
- b. Based on chained 1992 dollars.
- c. The GDP price index is virtually the same as the implicit GDP deflator.
- d. The consumer price index for all urban consumers.

Table 1-7.
Comparison of CBO's and Other Economists' Projections for Calendar Years 1998-2008

	Actual 1997	Forecast		Projected								
		1998	1999	2000	2001	2002	2003	2004	2005	2006	2007	2008
Nominal GDP												
(Percentage change)												
CBO	5.9	4.6	4.2	4.1	4.0	4.6	4.7	4.6	4.5	4.4	4.4	4.3
<i>Blue Chip</i>	5.8	4.9	4.5	4.7	4.8	5.0	5.1	5.0	n.a.	n.a.	n.a.	n.a.
Administration	5.8	4.7	4.0	4.2	4.4	4.6	4.6	4.7	4.7	4.6	4.6	4.6
Real GDP^a												
(Percentage change)												
CBO	3.9	3.4	2.2	1.9	1.8	2.4	2.5	2.4	2.3	2.3	2.2	2.2
<i>Blue Chip</i>	3.8	3.3	2.3	2.2	2.2	2.4	2.5	2.5	n.a.	n.a.	n.a.	n.a.
Administration	3.8	2.9	2.0	2.0	2.1	2.4	2.4	2.4	2.4	2.4	2.4	2.3
GDP Price Index^b												
(Percentage change)												
CBO	1.9	1.2	2.0	2.2	2.1	2.1	2.1	2.1	2.1	2.1	2.1	2.1
<i>Blue Chip</i>	2.0	1.5	2.1	2.4	2.6	2.5	2.5	2.5	n.a.	n.a.	n.a.	n.a.
Administration	2.0	1.7	2.0	2.1	2.2	2.2	2.2	2.2	2.2	2.2	2.2	2.2
Consumer Price Index^c												
(Percentage change)												
CBO	2.3	1.7	2.6	2.7	2.6	2.5	2.5	2.5	2.5	2.5	2.5	2.5
<i>Blue Chip</i>	2.3	1.7	2.4	2.7	2.7	2.8	2.7	2.7	n.a.	n.a.	n.a.	n.a.
Administration	2.3	1.6	2.1	2.2	2.3	2.3	2.3	2.3	2.3	2.3	2.3	2.3
Unemployment Rate												
(Percent)												
CBO	4.9	4.6	4.7	5.1	5.5	5.7	5.7	5.7	5.7	5.7	5.7	5.7
<i>Blue Chip</i>	4.9	4.5	4.7	5.3	5.5	5.6	5.4	5.4	n.a.	n.a.	n.a.	n.a.
Administration	5.0	4.7	5.0	5.2	5.4	5.4	5.4	5.4	5.4	5.4	5.4	5.4
Three-Month Treasury												
Bill Rate (Percent)												
CBO	5.1	5.1	5.2	4.8	4.6	4.4	4.4	4.4	4.4	4.4	4.4	4.4
<i>Blue Chip</i>	5.1	5.1	5.2	5.1	5.2	5.1	5.1	5.1	n.a.	n.a.	n.a.	n.a.
Administration	5.1	5.0	4.9	4.8	4.7	4.7	4.7	4.7	4.7	4.7	4.7	4.7
Ten-Year Treasury												
Note Rate (Percent)												
CBO	6.4	5.8	6.1	5.8	5.6	5.4	5.4	5.4	5.4	5.4	5.4	5.4
<i>Blue Chip</i>	6.4	5.6	5.8	6.0	6.1	6.1	6.1	6.1	n.a.	n.a.	n.a.	n.a.
Administration	6.4	5.6	5.6	5.6	5.6	5.6	5.6	5.6	5.6	5.6	5.6	5.6

SOURCES: Congressional Budget Office; Department of Commerce, Bureau of Economic Analysis; Department of Labor, Bureau of Labor Statistics; Capitol Publications, Inc.; Office of Management and Budget; Federal Reserve Board.

NOTES: The *Blue Chip* forecast, which is issued monthly, is from July 1998, and the projection, which is issued semiannually, is from March 1998.

n.a. = not available.

a. Based on chained 1992 dollars.

b. The GDP price index is virtually the same as the implicit GDP deflator.

c. The consumer price index for all urban consumers.

Early Recession. A number of ways exist in which the economy could slow during the rest of 1998 and perhaps fall into recession next year. One way is a severe decline in the stock market. Some analysts believe that the market was overvalued by 20 percent at midyear. If corporate profits turned out to be weaker than many analysts expect, the stock market might suffer a dramatic decline, which could cause businesses and consumers to scale back their spending plans.

Another route to recession might be higher real interest rates. Inflation could be greater than expected if the economy continued to grow rapidly or if the temporary factors restraining inflation dissipated faster than anticipated. Higher inflation could spur the Federal Reserve to raise the federal funds rate as a way to slow the economy and bring inflation back down. Although the Federal Reserve has had an exemplary record of managing monetary policy in recent years, mistakes are always possible, and if the federal funds rate was raised too far too quickly, the economy could be pushed into recession.

A further slump in exports might also slow the economy more than expected. That could happen if the recession in Japan depressed the region further and strengthened the dollar even more than it already has.

Extension of the Low-Inflation Boom. A continuation of the recent favorable developments might allow the economy to keep growing strongly through the end of 1999 or into 2000 without a resurgence of inflationary pressure. Continued low inflation in medical prices and declines in computer and oil prices would help keep a lid on the inflation rate for a time. A quick end to the economic problems in Asia might spur U.S. exports, and thus output growth, in the near term. However, such developments would only push back the date at which the economy would start to slow down.

Higher Trend in Productivity Growth: The New-Era Argument. CBO's forecast and projection could turn out to be pessimistic if the new-era argument proved correct. Some analysts maintain that the United States and many other economies have undergone, and will continue to undergo, major structural changes that in essence will cause the trend in produc-

tivity growth to be significantly higher over the next 10 years than it has been for the past 20.

The trend in the growth of labor productivity between 1973 and 1997 was 1.1 percent a year, and CBO's projection incorporates an average growth rate of 1.7 percent a year. Labor productivity is assumed to be higher than the trend for two reasons: the capital stock has grown rapidly in recent years, which will spur labor productivity growth, and the methodological changes to the CPI will increase the measured growth of real output (and hence of productivity) by 0.2 percentage points per year compared with the historical period.

The proponents of the new era argue that the spread of free-market principles, the reduction of trade barriers and increased international trade, the dismantling of regulations and government enterprises, the accelerated pace of technological change in general (and the information-based nature of technological change in particular), and the decline in marginal tax rates are likely to foster stronger productivity growth for many years to come. They do not argue that recessions will not occur or that productivity will not vary with changes in output growth, but they maintain that the trend in productivity will be higher—perhaps as much as 1 percentage point higher than CBO assumes.¹² That implies a trend in productivity growth similar to the one that prevailed in the United States between 1956 and 1973.

Clearly, if such a trend came to pass, it would cause CBO's projection to be radically pessimistic. The trend in real wage growth would be much higher, prices and profits would not be under pressure in the near term, and the federal budget surplus—in the absence of any legislative response—would be much greater. Inflation could be pushed lower by such a persistently favorable supply shock, and estimates of the NAIRU would fall as the country experienced additional years of low inflation with low unemployment. However, there is no evidence in current data that

12. Many economists believe that the measurement of productivity growth is biased downward because the measurement of price change is biased upward. That problem should not be confused with the arguments of the new-era proponents, who maintain that the trend in productivity, even as it is currently measured, will be higher than CBO assumes.

would justify such an acceleration in productivity growth.

The Year 2000 Problem. Another risk that is difficult to assess is the year 2000 problem—the possibility of economic disruptions stemming from the potential failure of some computer software and memory chips to recognize the year 2000. In the early days of software development, programmers often used two digits to signify the year; when such software attempts to deal with 2000, it will assume that the year is 1900. Problems have already surfaced. Some cash registers will not accept credit cards with expiration dates in 2000 or later, and a year 2000 test caused a safety mechanism to shut down an offshore oil-drilling platform. Lawsuits have been filed in connection with some of those problems.

The issue has many ramifications. Corporate investment in computers and software has been stimulated by concern over this problem, and although some of the investment is not productive (in the sense that it simply avoids a problem rather than enhancing productivity), the reassessment of computer systems will

probably, on balance, help productivity in the long run.

Another aspect is the threat to the U.S. and international payments system. Although large U.S. financial institutions are probably in good shape, many foreign banks and smaller U.S. institutions have not prepared for the problem. Check clearing and securities trading in this country will not be disrupted, but European institutions are preoccupied with the conversion to the single European currency, and Japanese banks do not appear to be analyzing the vulnerability of their systems.

In spite of all the possible ways the problem could upset the economy, CBO expects that the disruption will be relatively small and brief. The growth of productivity and output will most likely be slowed by 0.1 percentage point or less in 1999 and 2000 as firms and governments divert resources into checking, correcting, and litigating the problem, but there will be no sudden contraction of economic activity in either year.

The Budget Outlook

The Congressional Budget Office projects that total federal revenues will exceed total government expenditures by \$63 billion in 1998, the first surplus in the total budget since 1969. During the period since the last surplus—1970 through 1997—spending outstripped tax receipts by a cumulative \$3.4 trillion. The government financed those deficits by borrowing from private credit markets, driving up federal debt held by the public from \$278 billion at the end of 1969 to nearly \$3.8 trillion at the end of 1997.

Under current laws and policies, and providing that the economy performs as CBO assumes, the excess of total federal revenues over total outlays is estimated to grow over the next 10 years, rising from \$80 billion in 1999 to \$251 billion in 2008. If those projected surpluses are actually realized, past borrowing from the public will be partially repaid, and debt held by the public will fall to \$2.3 trillion by the end of 2008. As a percentage of gross domestic product, the decline in debt held by the public will be even more dramatic, plummeting from 47 percent in 1997 to 18 percent in 2008 (see Figure 2-1). Such a reduction in borrowing by the Department of the Treasury will release resources for private investment, thereby enhancing productivity and economic growth.

Total government inflows and outflows include the Social Security trust funds—Old-Age and Survivors Insurance and Disability Insurance—which have their own earmarked sources of revenue. Currently, income flowing into those funds exceeds outlays for benefits and program administration. The trust fund surpluses have, by law, been invested in interest-

bearing government securities, and that interest is part of the funds' income. Those investments have, in turn, reduced the need to borrow from the public to finance other programs.

Legislation enacted in 1985 gave off-budget status to the Social Security trust funds, and legislation in 1989 did the same for the much smaller net outlays of the Postal Service. Excluding those off-budget transactions from the total changes the bottom line, taking the remainder of the budget out of balance in 1998. CBO estimates that the off-budget surplus will total \$104 billion this year, which leaves an on-budget defi-

Figure 2-1.
Debt Held by the Public as a Share of GDP
(By fiscal year)

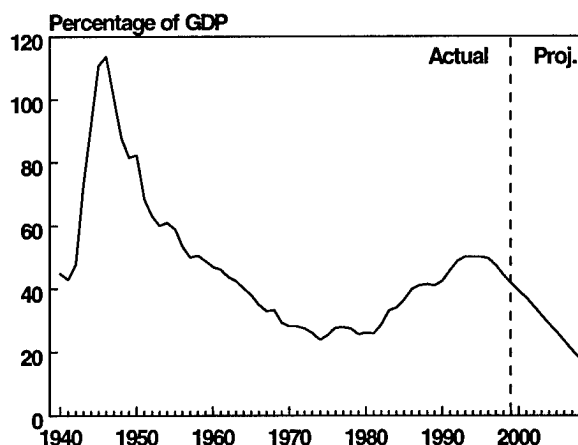

SOURCE: Congressional Budget Office.

cit of \$41 billion. The on-budget deficit is projected to give way to surpluses in 2002 and in 2005 through 2008.

By any measure, CBO's outlook for the federal budget has improved significantly since March. On the basis of actual data for the first nine months of fiscal year 1998, CBO has raised its estimate of this year's total budget surplus by \$55 billion. Revenues have been adjusted upward by \$38 billion (a 2 percent increase), and outlays have been adjusted downward by \$18 billion (a 1 percent decrease).

Only a very small part of those adjustments can be ascribed to a divergence from CBO's earlier economic forecast. On the outlay side, the revisions stem largely from an array of one-time occurrences. On the revenue side, they may be the result of such factors as unexpected growth in partnership income and bonuses, increases in payouts from pension plans, and the timing of capital gains realizations. The precise factors that have generated the higher-than-expected growth in revenues seen in 1998 will not be known for another two years, because many taxpayers have not yet filed their detailed returns for 1997 and 1998 returns will not be filed until next year. In projecting revenue growth for 1999 through 2008, CBO assumed that some of the factors causing the changes during the past year would persist or grow, whereas others would dissipate. Overall, CBO projects about \$50 billion per year in additional receipts.

If any of a number of assumptions that CBO has made turn out to be off the mark, however, budgetary outcomes could be quite different from the projections, even without changes in policy by the Congress. For instance, if CBO's economic projection proved overly optimistic, surpluses could be much lower than anticipated; a recession similar to that of the early 1990s could even produce a deficit for a few years. Likewise, surpluses could be lower than projected if the factors that produced the unexpected revenues in 1998 faded quickly. Of course, the economy could also be more robust than expected or the unexplained revenue surge could grow over time—in those circumstances, the budget outlook would be much brighter than CBO currently projects. In any case, results for any one year that differ by \$100 billion from current projections are entirely possible.

Changes in the fiscal position of the government tend to feed on themselves, thereby producing larger changes in the same direction. In the case of a "virtuous cycle," positive feedbacks occur as an initial shift in the budget from deficit to surplus reduces the federal debt. Outlays for interest are in turn reduced, which increases the surplus, and so on. Such a process is evident in CBO's new projections. By 2008, lower debt-service costs account for \$44 billion of the \$113 billion increase in CBO's projected surplus compared with the projections it released in March. But a reversal of today's "virtuous" fiscal forces could initiate a so-called vicious cycle—in which interest rates would probably rise and debt-service savings would be reduced. That kind of cycle might all too quickly eliminate the budget surpluses that are now envisioned.

An Improved Bottom Line

Since the record total deficit of \$290 billion in 1992, the federal budgetary picture has shown annual improvement. From that high mark six years ago, the deficit plunged to \$22 billion last year. This year, it is virtually certain that the total budget will be in surplus (see Table 2-1).

Under the assumptions of CBO's economic forecast and presuming that current policies remain the same, the positive outlook for the budget is projected to continue. CBO anticipates that the baseline total surplus will hover around \$80 billion for each of the next three years before rising to \$139 billion in 2002. By 2008, the surplus is projected to reach \$251 billion.

Rapidly rising revenues account for much of the improvement in the budgetary picture. Between 1992 and 1997, annual revenues grew by \$488 billion, or 45 percent. As a percentage of GDP, revenues over that period climbed from 17.8 percent to 19.8 percent. By way of contrast, annual outlays grew only moderately over the 1992-1997 period, rising by \$220 billion, or 16 percent. As a share of GDP, outlays dipped from 22.5 percent in 1992 to 20.1 percent in 1997. Over the coming decade, the pace of revenue growth is expected to slow to rates approximating those of GDP.

However, outlays are estimated to grow more slowly than the economy, and as a result, surpluses are projected to mount.

Although the total budget is expected to show a healthy surplus in 1998, CBO still anticipates an on-budget deficit (see Figure 2-2). On-budget revenues (which by law exclude revenues earmarked for Social Security) are projected to be \$41 billion less than on-budget spending (which, again, excludes spending for Social Security benefits and administrative costs as well as the net outlays of the Postal Service). That figure is down considerably from the \$103 billion on-budget deficit recorded in 1997 and the record-high

\$340 billion on-budget deficit in 1992. In 2002 and again in 2005 through 2008, CBO projects, the budget will be balanced even when off-budget revenues and spending are excluded from the calculations. The on-budget surplus is projected to reach \$64 billion in 2008.

The two Social Security trust funds are currently running a combined surplus of about \$100 billion a year, which includes the income from interest on government securities. By 2008, the annual Social Security surplus will approach \$190 billion. Yet those surpluses will start to shrink when the baby boomers begin to retire. CBO's detailed estimates do not extend

Table 2-1.
The Budget Outlook Under Current Policies (By fiscal year)

	Actual 1997	1998	1999	2000	2001	2002	2003	2004	2005	2006	2007	2008
In Billions of Dollars												
Total Deficit (-) or Surplus	-22	63	80	79	86	139	136	154	170	217	236	251
On-Budget Deficit (-) or Surplus (Excluding Social Security and the Postal Service)	-103	-41	-37	-46	-45	1	-10	a	5	44	55	64
Memorandum:												
Off-Budget Surplus												
Social Security	81	105	117	126	130	138	146	154	165	173	181	186
Postal Service	<u>a</u>	<u>a</u>	<u>a</u>	<u>a</u>	<u>1</u>	<u>0</u>	<u>0</u>	<u>0</u>	<u>0</u>	<u>0</u>	<u>0</u>	<u>0</u>
Total	81	104	117	125	131	138	146	154	165	173	181	186
Total Deficit (-) or Surplus If Discretionary Spending Was Frozen at the 2002 Level from 2003 to 2008	-22	63	80	79	86	139	150	184	217	282	320	355
As a Percentage of GDP												
Total Deficit (-) or Surplus	-0.3	0.8	0.9	0.9	0.9	1.4	1.3	1.4	1.5	1.8	1.9	1.9
On-Budget Deficit (-) or Surplus (Excluding Social Security and the Postal Service)	-1.3	-0.5	-0.4	-0.5	-0.5	b	-0.1	b	b	0.4	0.4	0.5

SOURCE: Congressional Budget Office.

a. Less than \$500 million.

b. Less than 0.05 percent.

Figure 2-2.
Total and On-Budget Deficit or Surplus
(By fiscal year)

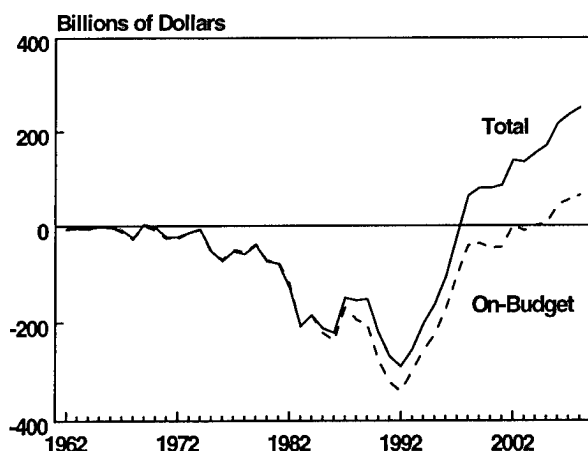

SOURCE: Congressional Budget Office.

past 2008, but according to the intermediate estimates of the Social Security actuaries, payroll tax revenues will be insufficient to cover outgo from the funds starting in 2013. Total income (including interest) is expected to fall short of outgo beginning in 2021, and the funds are due to be exhausted in 2032. (Box 2-1 discusses the long-term budget outlook.)

Changes in Projections Since March

Actual revenue collections for 1998, as reported by the Treasury through June, have been higher and actual outlays lower than CBO had anticipated in March (before receipts for the key month of April were known). Revenues now seem likely to reach \$1,717 billion this year—\$38 billion higher than the March estimate (see Table 2-2). CBO also expects total outlays for 1998 in the vicinity of \$1,654 billion—\$18 billion less than was projected in March.

The unexpectedly high level of receipts in 1998 has led CBO to boost its projection of revenues in later years because some of the factors that affected tax collections in 1998 will probably continue to have an impact. The reductions in spending in 1998, by contrast, stem largely from temporary factors, which

have little effect on CBO's projections of outlays beyond 1998.

CBO's spending and revenue projections incorporate the effects of legislation enacted since March, but those effects are relatively small. Changes prompted by CBO's new economic projections have had a greater influence on the projections of budget surpluses, but again, those effects were not nearly as important as the revisions stemming from the increased 1998 revenues. The most significant shift in the economic outlook is a decline in projected inflation, but that change has a limited impact on CBO's projected surpluses because it lowers both spending and revenues.

Changes in Projected Revenues

Changes to CBO's estimate of revenues add \$38 billion to the anticipated 1998 surplus compared with the surplus projected in CBO's report *An Analysis of the President's Budgetary Proposals for Fiscal Year 1999*, published in March 1998. Revisions to data on aggregate wages and salaries, corporate profits, and other variables reported in the national income and product accounts, as well as changes in CBO's forecast of those NIPA variables, explain about \$7 billion of the increase. Legislation enacted since March accounts for an additional \$1 billion. The remaining \$30 billion is ascribed to other, so-called technical factors. Overall, in 1998, CBO has added \$45 billion in technical reestimates to its revenue forecast—\$15 billion relative to the baseline reported in January's *The Economic and Budget Outlook* and \$30 billion relative to the baseline reported in March.

That story carries through the entire projection period as technical changes dominate the revisions in revenues through 2008. Technical revisions are defined as any changes that are not attributed to legislation or modifications in the macroeconomic forecast. Those changes may actually be economic in nature but not directly tied to CBO's economic forecast—for example, changes in capital gains realizations, which are excluded from income in the NIPA data. Technical revisions average around \$50 billion per year from 1999 through 2008 (see Chapter 3 for a more detailed discussion).

Box 2-1.
CBO's Long-Term Budget Outlook

The Congressional Budget Office (CBO) projects rising federal budget surpluses over the next 10 years. In the following decades, however, the budget will face mounting pressure as increasing numbers of the baby-boom generation begin to draw benefits from Social Security and Medicare and federal health costs per beneficiary continue to rise faster than the average wage. To analyze the magnitude of that pressure, CBO has produced long-term projections of the federal budget.

In contrast to CBO's 10-year projections, the long-term projections extend many spending and revenue categories using simple rules based on historical patterns, not current law. For example, CBO assumes that tax revenues and government purchases of goods and services remain constant as a share of output. However, projections for the federal health and retirement programs, which account for most of the long-run pressure on the budget, are extrapolated on the basis of the projections of the trustees of the Social

Security and Medicare trust funds. The trustees, in developing their projections, assume current law.¹

CBO's long-term projections indicate that the ratio of federal debt to gross domestic product (GDP) will fall close to zero over the next two decades but will then begin to rise, reaching 100 percent by 2048 (see the figure below). That outlook represents an improvement over the projections made in May 1998.² At that time, CBO projected that debt would exceed 100 percent of GDP soon after 2040. The improvement stems almost entirely from changes in CBO's 10-year projections. If reductions in revenues or increases in spending eliminated the surpluses projected for the next 10 years, the outlook would be significantly worse—CBO projects that in those circumstances, debt would rise above 100 percent of GDP by 2032.

The degree of long-term imbalance in the budget can be summarized in a single number: the fiscal gap. The fiscal gap is the size of the immediate and permanent revenue increase, or spending decrease, that would ensure that the debt-to-GDP ratio in 2070 would be at the same level that it is today. CBO currently estimates that the fiscal gap is 1.2 percent of GDP. In May, CBO estimated that the fiscal gap was 1.6 percent of GDP. Therefore, the improved 10-year projections for the budget have reduced the long-term imbalance by about one-quarter. If, however, the surpluses were eliminated, leaving the budget exactly balanced over the next 10 years, the estimated fiscal gap would reach 2.4 percent of GDP.

**Long-Term Projections of Debt
as a Share of GDP (By fiscal year)**

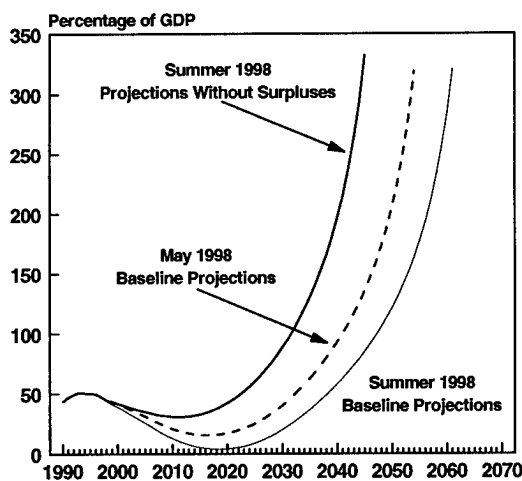

SOURCE: Congressional Budget Office.

1. See Congressional Budget Office, *An Economic Model for Long-Run Budget Simulations*, CBO Memorandum (July 1997), for a detailed description of the methodology CBO uses for its long-term projections.
2. Congressional Budget Office, *Long-Term Budgetary Pressures and Policy Options* (May 1998). The projections in that publication were based on CBO's 10-year projections detailed in *The Economic and Budget Outlook: Fiscal Years 1999-2008* (January 1998).

Changes in CBO's economic projections also affect estimates of revenues, and over the next few years, the revised economic assumptions increase those estimates by as much as \$15 billion a year. After 2002, however, the revised outlook reduces revenues by amounts that grow to \$43 billion in 2008. Those changes are the net outcome of certain factors that raise revenues and others that lower them. For instance, slightly higher real GDP and a slower decline in corporate profits as a share of GDP boost projected revenues in the next few years. But after 2002, lower projected rates of inflation push down nominal GDP and incomes, resulting in a drop in revenues that more than offsets those upward effects. Because lower

inflation also pushes down spending, however, it does not have a major impact on the budget surplus.

Legislative changes, primarily resulting from the Internal Revenue Service Restructuring and Reform Act of 1998, are expected to increase revenues in some years and decrease them in others—but by no more than \$1 billion in any year.

Changes in Projected Outlays

CBO anticipates that 1998 outlays will be \$18 billion lower than it projected in March. About \$5 billion of

Table 2-2.
Changes in CBO Budget Projections Since March 1998 (By fiscal year)

	1998	1999	2000	2001	2002	2003	2004	2005	2006	2007	2008
March 1998 Baseline Surplus	8	9	1	13	67	53	70	75	115	130	138
Changes											
Legislative											
Revenues	1	1	a	-1	-1	-1	-1	1	1	1	1
Outlays ^b	-1	-3	-4	-4	-4	-3	-2	-1	-1	a	1
Subtotal	a	-2	-4	-5	-5	-4	-4	a	1	1	2
Economic											
Revenues	7	13	15	5	a	-3	-10	-17	-24	-33	-43
Outlays ^b	1	9	10	12	16	24	32	40	48	56	63
Subtotal	8	22	25	17	16	21	22	24	23	23	21
Technical											
Revenues	30	48	50	51	49	50	49	51	52	52	55
Outlays ^b											
Other than debt service	16	-1	a	-1	-1	a	-2	-1	a	1	1
Debt service	1	4	7	10	13	16	19	22	26	30	34
Subtotal	48	51	57	61	61	66	65	72	78	83	90
Total Changes	55	71	78	73	72	82	84	96	102	106	113
Summer 1998 Baseline Surplus	63	80	79	86	139	136	154	170	217	236	251
Memorandum:											
Total Change in Revenues	38	62	65	56	48	46	37	35	29	20	13
Total Change in Outlays	18	9	13	17	23	37	46	61	73	86	99

SOURCE: Congressional Budget Office.

a. Less than \$500 million.

b. Increases in outlays are shown with a negative sign because they reduce surpluses.

that reduction occurs in discretionary spending. A supplemental appropriation bill enacted in May boosted discretionary spending by an estimated \$1 billion, but the increase was more than offset by slower-than-anticipated spending for a myriad of programs. For instance, spending for highway construction and maintenance is likely to be more than \$1 billion lower than CBO projected in March, largely because of uncertainties and delays associated with the reauthorization of highway programs. In addition, spending for disaster relief is now expected to be \$1 billion less than previously estimated. Projected spending for a variety of natural resources and environmental programs is also likely to drop by a total of about \$1 billion. Estimated outlays for various other discretionary programs have been reduced by smaller amounts.

Lower projected spending for mandatory programs in 1998 accounts for the remaining \$12 billion dip in outlays. More than \$1 billion of that total reflects economic effects—unemployment and interest rates that are lower than previously anticipated. Legislation enacted since March has had virtually no effect on net mandatory spending.

Thus, the leftover \$11 billion reduction in projected mandatory spending is attributable to other, technical factors. More than \$3 billion of the drop comes from the Medicare program, largely as the result of a decision by the Health Care Financing Administration to slow its processing of payments to health care providers. In addition, CBO has trimmed net outlays by nearly \$2 billion because proceeds from the sale of the United States Enrichment Corporation were received in 1998 rather than in 1999, as previously projected. CBO had also assumed that \$1.5 billion would be paid in 1998 as part of the settlement stemming from the 1996 Supreme Court decision that held the federal government liable for losses that savings and loan institutions incurred as a result of statutory changes affecting the definition of capital for regulatory standards. It now appears that payments this year will be much less than \$1.5 billion. CBO has also cut its estimates of spending for a variety of other mandatory programs.

Lower outlays in 1998 have not led to further technical reductions in 1999 through 2008. Rather,

the 1998 reductions for the most part reflect one-time events that either have no impact on future spending or are likely to increase it. For example, the slowdown in Medicare payments will curtail 1998 spending but have little or no effect on spending in future years, because the amount saved in any year as a result of the delay will roughly equal the amount of spending that is carried over from the previous year. However, as a result of technical revisions to its projections of revenues, CBO has lowered the amount of debt held by the public that it anticipates in the future. That reduction in turn shrinks the government's estimated interest payments throughout the projection period. By 2008, such reductions total \$34 billion.

Legislation enacted since March has increased projected spending over the 1999-2008 period by a total of \$23 billion. Most of that increase comes from the additional funds provided by the Transportation Equity Act for the 21st Century, which was enacted in June. Additional spending for highways and mass transit was only partially offset by reductions in other discretionary and mandatory spending. Most of the mandatory savings arose from the overturning of a 1997 decision by the Department of Veterans Affairs that had made it easier for veterans who suffer from smoking-related diseases to qualify for compensation benefits.

Changes in CBO's economic forecast have reduced projected spending by amounts that grow to \$63 billion by 2008. By 2002, CBO anticipates that short-term interest rates will be 0.3 percentage points and long-term rates 0.5 percentage points below its previous forecast. Those changes push down projected net interest payments by \$10 billion in 2008. Reductions in nominal interest rates are almost entirely the consequence of lower projected inflation. Lower inflation also restrains the size of required cost-of-living adjustments for benefit programs such as Social Security and slows the growth of Medicare spending. Furthermore, since CBO's projections assume that discretionary spending will grow at the rate of inflation after the statutory caps on such spending expire in 2002, the decline in projected inflation also curbs expected discretionary spending from 2003 through 2008.

Revenue and Spending Projections

CBO projects that revenues this year will reach a post-World War II high of 20.5 percent of GDP. Without any changes in policy, revenues are expected to slightly exceed that level next year before falling to a long-run share of GDP that equals the revenue share in 1997 (see Table 2-3).

CBO assumes that the unexplained increase in 1998 revenues will carry over into 1999—thus boosting their share of GDP to 20.6 percent. Revenues are expected to subside to 20.3 percent of GDP in 2000 and to 19.8 percent by 2003. Most of that decline occurs because individual income taxes decline as a share of output. After 2003, individual income tax receipts as a share of GDP should climb steadily as growth in real incomes causes more income to be taxed at higher rates. Offsetting the rising share of GDP stemming from individual income taxes is a decline in excise taxes relative to GDP. Those counterbalancing trends keep the total revenue share constant at 19.8 percent from 2003 through 2008. Over the entire 1998-2008 period, therefore, annual growth in revenues is projected to match the 4.5 percent average growth in nominal GDP.

On the other side of the ledger, outlays are projected to grow more slowly than revenues, averaging 3.4 percent annually from 1998 through 2008. In dollar terms, CBO expects total outlays to grow from \$1,654 billion in 1998 to \$2,303 billion in 2008. As a percentage of GDP, however, outlays are projected to decline throughout the period—from 19.7 percent of GDP in 1998 to 17.9 percent in 2008.

Discretionary spending is currently restrained through 2002 by an assortment of caps (see Appendix B). Those caps, if left intact, will hold total growth of such spending to less than 3 percent from 1998 through 2002. (In real terms, discretionary outlays would be reduced by 7 percent.) After 2002, CBO assumes that discretionary spending will grow

at the rate of inflation. Even so, such spending is projected to decline from 6.6 percent of GDP in 1998 to 5.1 percent in 2008.

The Transportation Equity Act for the 21st Century created two additional sets of caps on budget authority and outlays: one set for highway spending and one for mass transit (see Table 2-4). Those caps are in addition to the caps on defense, domestic and international, and violent crime reduction spending that were already in place. In 1999, all five sets of caps on budget authority and outlays will be in effect. Then in 2000, the number of sets of caps drops to four as defense is combined with domestic and international spending to form one category. In 2001 and 2002, violent crime reduction is merged with defense, domestic, and international spending under one set of caps for all such programs. The separate caps on highway and mass transit outlays extend through 2002.

Spending for entitlements and other mandatory programs, by far the largest spending category, is expected to total \$942 billion this year and is growing faster than the economy. Fueling that growth are expenditures for Medicare and Medicaid, which together with Social Security account for roughly three-quarters of all mandatory outlays (see Table 2-5 on page 43). CBO projects that total mandatory spending will grow from 11.2 percent of GDP in 1998 to 12.6 percent in 2008.

Net interest, which was the fastest-growing category of spending in the 1980s, is now expected to decline. As projected surpluses reduce the stock of debt held by the public by \$1.4 trillion, net interest will drop from \$244 billion (2.9 percent of GDP) in 1998 to \$140 billion (1.1 percent of GDP) in 2008 (see Table 2-6 on page 44). Debt subject to limit, however, is projected to continue rising through 2007 because the surpluses that accrue to the Social Security trust funds and other accounts are expected to be larger than the surpluses tallied in the total budget. The debt limit, which currently stands at \$5.95 trillion, should be sufficient until at least the middle of fiscal year 2003.

Table 2-3.
CBO Budget Projections, Assuming Compliance with Discretionary Spending Caps (By fiscal year)

	Actual 1997	1998	1999	2000	2001	2002	2003	2004	2005	2006	2007	2008
In Billions of Dollars												
Revenues												
Individual income	737	821	850	867	892	933	968	1,014	1,065	1,116	1,170	1,227
Corporate income	182	190	196	201	201	204	210	218	228	239	250	262
Social insurance	539	577	604	629	652	678	706	737	772	805	839	871
Other	120	129	150	152	157	163	169	174	178	182	187	193
Total	1,579	1,717	1,801	1,848	1,903	1,978	2,053	2,142	2,243	2,342	2,446	2,553
On-budget	1,187	1,296	1,359	1,388	1,425	1,481	1,534	1,601	1,675	1,750	1,829	1,911
Off-budget	392	421	442	460	478	497	519	541	568	592	618	643
Outlays												
Discretionary spending	548	552	564	569	570	567	581	595	610	626	641	657
Mandatory spending	896	942	997	1,052	1,115	1,165	1,234	1,303	1,389	1,443	1,531	1,626
Offsetting receipts	-87	-84	-79	-84	-90	-101	-96	-99	-104	-109	-115	-121
Net interest	244	244	238	232	221	209	198	189	178	166	153	140
Total	1,601	1,654	1,721	1,769	1,817	1,840	1,918	1,988	2,073	2,126	2,211	2,303
On-budget	1,291	1,337	1,396	1,434	1,470	1,480	1,545	1,601	1,670	1,706	1,774	1,846
Off-budget	311	317	325	335	347	359	373	387	402	419	437	456
Deficit (-) or Surplus	-22	63	80	79	86	139	136	154	170	217	236	251
On-budget deficit (-) or surplus	-103	-41	-37	-46	-45	1	-10	a	5	44	55	64
Off-budget surplus	81	104	117	125	131	138	146	154	165	173	181	186
Debt Held by the Public	3,771	3,717	3,655	3,589	3,518	3,395	3,275	3,136	2,981	2,779	2,557	2,320
As a Percentage of GDP												
Revenues												
Individual income	9.3	9.8	9.7	9.5	9.4	9.4	9.3	9.3	9.4	9.4	9.5	9.5
Corporate income	2.3	2.3	2.2	2.2	2.1	2.1	2.0	2.0	2.0	2.0	2.0	2.0
Social insurance	6.8	6.9	6.9	6.9	6.9	6.8	6.8	6.8	6.8	6.8	6.8	6.8
Other	1.5	1.5	1.7	1.7	1.7	1.6	1.6	1.6	1.6	1.5	1.5	1.5
Total	19.8	20.5	20.6	20.3	20.1	20.0	19.8	19.8	19.8	19.8	19.8	19.8
On-budget	14.9	15.4	15.5	15.2	15.0	15.0	14.8	14.8	14.8	14.8	14.8	14.8
Off-budget	4.9	5.0	5.0	5.0	5.0	5.0	5.0	5.0	5.0	5.0	5.0	5.0
Outlays												
Discretionary spending	6.9	6.6	6.4	6.2	6.0	5.7	5.6	5.5	5.4	5.3	5.2	5.1
Mandatory spending	11.2	11.2	11.4	11.5	11.8	11.8	11.9	12.0	12.3	12.2	12.4	12.6
Offsetting receipts	-1.1	-1.0	-0.9	-0.9	-0.9	-1.0	-0.9	-0.9	-0.9	-0.9	-0.9	-0.9
Net interest	3.1	2.9	2.7	2.5	2.3	2.1	1.9	1.7	1.6	1.4	1.2	1.1
Total	20.1	19.7	19.7	19.4	19.2	18.6	18.5	18.3	18.3	18.0	17.9	17.9
On-budget	16.2	15.9	15.9	15.7	15.5	14.9	14.9	14.8	14.7	14.4	14.4	14.3
Off-budget	3.9	3.8	3.7	3.7	3.7	3.6	3.6	3.6	3.6	3.5	3.5	3.5
Deficit (-) or Surplus	-0.3	0.8	0.9	0.9	0.9	1.4	1.3	1.4	1.5	1.8	1.9	1.9
On-budget deficit (-) or surplus	-1.3	-0.5	-0.4	-0.5	-0.5	b	-0.1	b	b	0.4	0.4	0.5
Off-budget surplus	1.0	1.2	1.3	1.4	1.4	1.4	1.4	1.4	1.5	1.5	1.5	1.4
Debt Held by the Public	47.3	44.3	41.7	39.3	37.1	34.3	31.6	28.9	26.3	23.5	20.7	18.0

SOURCE: Congressional Budget Office.

a. Deficit of less than \$500 million.

b. Deficit or surplus of less than 0.05 percent of GDP.

Table 2-4.
CBO Projections of Discretionary Outlays, Assuming Compliance with Discretionary Spending Caps
(By fiscal year, in billions of dollars)

	Actual 1997	1998	1999	2000	2001	2002
Defense	272	270	268	a	a	a
Domestic and International	252	258	265	a	a	a
Violent Crime Reduction	2	4	5	6	a	a
Highways	19	19	22	24	26	27
Mass Transit	3	2	4	5	5	6
All Other ^b	<u>n.a.</u>	<u>n.a.</u>	<u>n.a.</u>	<u>534</u>	<u>539</u>	<u>534</u>
Total	548	552	564	569	570	567

SOURCE: Congressional Budget Office.

NOTE: n.a. = not applicable.

- a. After these caps expire, this amount is reflected in the "All Other" category.
 b. Represents all discretionary outlays that fall under the overall cap but are not governed by caps for particular categories in that year.

The Federal Sector of the National Income and Product Accounts

The projections summarized so far in this chapter draw on the usual labels—revenues by source, outlays by category—that are familiar to policymakers. Economists, though, often use another approach for measuring the government's activities. The federal sector of the national income and product accounts divides the government's spending and receipts into categories that are conventionally used to analyze domestic production and income. That categorization allows analysts to track the relationship between the government and other sectors of the economy.

Only a few major differences distinguish the NIPA versions of federal receipts and expenditures from their counterparts in the budget. Netting and grossing adjustments move some collections, mainly those labeled in the budget as offsetting receipts (such as Medicare premiums), from the spending to the receipts side of the NIPAs (see Table 2-7 on page 45). The budget records most such collections as negative out-

lays because they do not result from the government's taxing power. Shifting them to the receipts side of the NIPA ledger offers a fuller picture of government receipts, regardless of source, and does not affect the total deficit or surplus.

Macroeconomic analysis typically disregards transactions that merely reflect the transfer of existing assets and liabilities and that do not contribute to current production. The NIPAs therefore exclude lending and financial transactions that appear in the budget. Prominent among such adjustments are those for deposit insurance outlays, cash flows for direct loans made before credit reform, and the Federal Communications Commission's auctions of portions of the electromagnetic spectrum. Other, relatively minor factors that cause the NIPA and budget totals to diverge are geographic adjustments (the exclusion of Puerto Rico, the Virgin Islands, and a few other areas from domestic economic statistics) and timing adjustments (such as adjustments for irregular numbers of benefit checks or paychecks because of calendar quirks).

The NIPAs and the total budget also differ in their treatment of investment and capital consumption. The total budget includes all federal government expendi-

Table 2-5.
CBO Projections of Mandatory Spending, Including Deposit Insurance
(By fiscal year, in billions of dollars)

	Actual 1997	1998	1999	2000	2001	2002	2003	2004	2005	2006	2007	2008
Means-Tested Programs												
Medicaid	96	101	109	115	123	131	141	152	165	179	194	210
State Children's Health Insurance Program	a	a	1	3	4	4	4	4	4	4	4	5
Food Stamps	23	21	22	23	25	26	27	28	29	30	30	31
Supplemental Security Income	27	27	28	29	31	33	35	37	42	41	39	45
Family Support ^b	17	18	21	22	23	23	24	24	25	25	25	26
Veterans' Pensions	3	3	3	3	3	3	4	4	4	4	4	4
Child Nutrition	8	9	9	10	10	11	11	12	12	13	13	14
Earned Income Credit ^c	22	24	26	27	28	29	29	30	30	31	31	32
Student Loans	4	3	4	4	5	5	5	5	5	5	5	6
Other	<u>4</u>	<u>4</u>	<u>5</u>	<u>5</u>	<u>6</u>	<u>6</u>	<u>6</u>	<u>7</u>	<u>7</u>	<u>8</u>	<u>8</u>	<u>9</u>
Total	203	209	228	243	257	270	285	302	323	339	355	381
Non-Means-Tested Programs												
Social Security	362	376	389	406	425	446	467	489	513	539	567	597
Medicare	<u>208</u>	<u>214</u>	<u>230</u>	<u>243</u>	<u>266</u>	<u>275</u>	<u>302</u>	<u>325</u>	<u>359</u>	<u>368</u>	<u>406</u>	<u>435</u>
Subtotal	570	590	620	649	691	720	768	814	873	907	973	1,033
Other Retirement and Disability												
Federal civilian ^d	46	48	50	52	55	57	60	63	67	71	74	78
Military	30	31	32	33	34	35	36	37	38	39	40	41
Other	<u>4</u>	<u>5</u>	<u>5</u>	<u>5</u>	<u>5</u>	<u>5</u>	<u>5</u>	<u>5</u>	<u>5</u>	<u>5</u>	<u>5</u>	<u>5</u>
Subtotal	81	84	86	90	94	98	102	106	110	115	120	125
Unemployment Compensation	21	19	21	22	25	26	27	29	30	31	32	33
Deposit Insurance	-14	-4	-4	-3	-2	-2	-1	-1	-1	-1	-1	-1
Other Programs												
Veterans' benefits ^e	19	21	21	22	22	23	23	24	26	25	23	25
Farm price and income supports	6	8	7	6	5	5	5	5	5	5	5	5
Social services	5	5	5	6	5	5	5	5	5	5	5	5
Credit reform liquidating accounts	-10	-7	a	-6	-6	-6	-6	-6	-6	-6	-6	-6
Other	<u>17</u>	<u>17</u>	<u>14</u>	<u>24</u>	<u>25</u>	<u>26</u>	<u>26</u>	<u>26</u>	<u>24</u>	<u>24</u>	<u>25</u>	<u>26</u>
Subtotal	37	44	47	52	51	52	53	53	54	52	51	55
Total	694	733	769	810	859	895	949	1,001	1,066	1,105	1,176	1,245
Total												
All Mandatory Spending	896	942	997	1,052	1,115	1,165	1,234	1,303	1,389	1,443	1,531	1,626

SOURCE: Congressional Budget Office.

NOTE: Spending for the benefit programs shown above generally excludes administrative costs, which are discretionary. Spending for Medicare also excludes premiums, which are considered offsetting receipts.

- Less than \$500 million.
- Includes Temporary Assistance for Needy Families, Family Support, Aid to Families with Dependent Children, Job Opportunities and Basic Skills, Contingency Fund for State Welfare Programs, Child Care Entitlements to States, and Children's Research and Technical Assistance.
- Includes outlays from the child credit enacted in the Taxpayer Relief Act of 1997.
- Includes Civil Service, Foreign Service, Coast Guard, and other retirement programs, and annuitants' health benefits.
- Includes veterans' compensation, readjustment benefits, life insurance, and housing programs.

tures, including purchases such as buildings and aircraft carriers, that could be considered investments. The NIPA version shows the current, or operating, account for the federal government; consequently, government investment is left out, and the government's consumption of fixed capital (depreciation) is included.

The NIPA federal sector generally portrays receipts according to their sources and expenditures according to their purpose and destination (see Table 2-8). Receipts are split into four large categories: personal tax and nontax receipts, tax accruals from corporate profits, indirect business tax and nontax

Table 2-6.
CBO Projections of Federal Interest Costs and Debt (By fiscal year)

	Actual 1997	1998	1999	2000	2001	2002	2003	2004	2005	2006	2007	2008
Net Interest Outlays (Billions of dollars)												
Interest on Gross Federal Debt (Gross interest) ^a	356	363	363	365	363	360	357	357	357	356	354	352
Interest Received by Trust Funds												
Social Security	-41	-46	-51	-57	-64	-70	-77	-84	-91	-99	-108	-117
Other trust funds ^b	<u>-64</u>	<u>-67</u>	<u>-67</u>	<u>-70</u>	<u>-72</u>	<u>-73</u>	<u>-75</u>	<u>-77</u>	<u>-79</u>	<u>-81</u>	<u>-84</u>	<u>-86</u>
Subtotal	-105	-113	-118	-128	-136	-143	-151	-161	-170	-180	-191	-202
Other Interest ^c	<u>-7</u>	<u>-6</u>	<u>-7</u>	<u>-6</u>	<u>-7</u>	<u>-7</u>	<u>-8</u>	<u>-8</u>	<u>-9</u>	<u>-9</u>	<u>-10</u>	<u>-10</u>
Total	244	244	238	232	221	209	198	189	178	166	153	140
Federal Debt at the End of the Year (Billions of dollars)												
Gross Federal Debt	5,370	5,475	5,594	5,721	5,845	5,927	6,021	6,102	6,174	6,205	6,223	6,222
Debt Held by Government Accounts												
Social Security	631	736	853	978	1,108	1,246	1,392	1,547	1,712	1,885	2,066	2,252
Other accounts	<u>968</u>	<u>1,022</u>	<u>1,087</u>	<u>1,154</u>	<u>1,219</u>	<u>1,286</u>	<u>1,354</u>	<u>1,419</u>	<u>1,481</u>	<u>1,541</u>	<u>1,600</u>	<u>1,650</u>
Subtotal	1,599	1,757	1,939	2,132	2,327	2,532	2,746	2,966	3,193	3,426	3,665	3,902
Debt Held by the Public	3,771	3,717	3,655	3,589	3,518	3,395	3,275	3,136	2,981	2,779	2,557	2,320
Debt Subject to Limit ^d	5,328	5,437	5,557	5,685	5,810	5,893	5,988	6,072	6,145	6,178	6,196	6,196
Federal Debt as a Percentage of GDP												
Debt Held by the Public	47.3	44.3	41.7	39.3	37.1	34.3	31.6	28.9	26.3	23.5	20.7	18.0

SOURCE: Congressional Budget Office.

NOTE: Projections of interest and debt assume that discretionary spending will equal the statutory caps that are in effect through 2002 and will grow at the rate of inflation in succeeding years.

- Excludes interest costs of debt issued by agencies other than the Treasury (primarily the Tennessee Valley Authority).
- Principally Civil Service Retirement, Military Retirement, Medicare, unemployment insurance, and the Highway and the Airport and Airway Trust Funds.
- Primarily interest on loans to the public.
- Differs from the gross federal debt primarily because most debt issued by agencies other than the Treasury is excluded from the debt limit.

Table 2-7.
Relationship of the Budget to the Federal Sector of the National Income and Product Accounts
(By fiscal year, in billions of dollars)

	Actual 1997	1998	1999	2000	2001	2002	2003	2004	2005	2006	2007	2008
Receipts												
Revenue (Budget basis) ^a	1,579	1,717	1,801	1,848	1,903	1,978	2,053	2,142	2,243	2,342	2,446	2,553
Differences												
Netting and grossing												
Government contributions for employee retirement	71	72	73	76	78	80	82	85	87	90	93	96
Medicare premiums	20	21	23	25	28	31	34	38	42	46	50	54
Deposit insurance premiums	5	b	b	b	b	b	b	b	b	b	b	b
Other	7	3	4	1	1	1	1	-2	-2	-3	-4	-5
Geographic exclusions	-3	-3	-3	-3	-3	-4	-4	-4	-4	-4	-4	-5
Excise timing adjustments	1	6	-7	0	0	0	0	0	0	0	0	0
Universal Service Fund Receipts	-1	-3	-6	-9	-12	-13	-13	-13	-13	-14	-14	-14
Other	<u>12</u>	<u>1</u>	<u>6</u>	<u>7</u>	<u>6</u>	<u>6</u>	<u>7</u>	<u>7</u>	<u>7</u>	<u>7</u>	<u>7</u>	<u>7</u>
Total	113	97	90	96	97	102	107	112	117	122	128	134
Receipts (NIPA basis)	1,692	1,814	1,891	1,944	2,000	2,080	2,160	2,254	2,360	2,464	2,574	2,687
Expenditures												
Outlays (Budget basis) ^a	1,601	1,654	1,721	1,769	1,817	1,840	1,918	1,988	2,073	2,126	2,211	2,303
Differences												
Netting and grossing												
Government contributions for employee retirement	71	72	73	76	78	80	82	85	87	90	93	96
Medicare premiums	20	21	23	25	28	31	34	38	42	46	50	54
Deposit insurance premiums	5	b	b	b	b	b	b	b	b	b	b	b
Other	7	3	4	1	1	1	1	-2	-2	-3	-4	-5
Lending and financial transactions	29	13	9	10	11	18	8	7	8	9	9	8
Defense timing adjustment	b	-1	1	1	0	0	0	0	0	0	0	0
Geographic exclusions	-9	-10	-10	-11	-11	-11	-12	-12	-13	-13	-14	-15
Treatment of investment and depreciation	10	10	9	9	8	9	7	6	4	3	1	b
Mandatory timing adjustments	0	0	0	0	-5	5	0	0	-14	9	6	0
Universal Service Fund Payments	-1	-2	-6	-9	-12	-13	-13	-13	-13	-14	-14	-14
Other	<u>4</u>	<u>-2</u>	<u>-2</u>	<u>-2</u>	<u>-2</u>	<u>-2</u>	<u>-2</u>	<u>-2</u>	<u>-2</u>	<u>-2</u>	<u>-2</u>	<u>-2</u>
Total	136	105	102	100	97	118	105	107	96	124	125	123
Expenditures (NIPA basis)	1,737	1,759	1,823	1,869	1,914	1,957	2,023	2,095	2,169	2,249	2,335	2,425
Deficit or Surplus												
Deficit (-) or Surplus (Budget basis) ^a	-22	63	80	79	86	139	136	154	170	217	236	251
Differences												
Lending and financial transactions	-29	-13	-9	-10	-11	-18	-8	-7	-8	-9	-9	-8
Defense timing adjustment	b	1	-1	-1	0	0	0	0	0	0	0	0
Geographic exclusions	7	7	7	7	8	8	8	9	9	9	10	10
Treatment of investment and depreciation	-10	-10	-9	-9	-8	-9	-7	-6	-4	-3	-1	b
Mandatory and excise timing adjustments	1	6	-7	0	5	-5	0	0	14	-9	-6	0
Universal Service Fund	b	-1	0	0	0	0	0	0	0	0	0	0
Other	<u>8</u>	<u>2</u>	<u>8</u>	<u>8</u>	<u>8</u>	<u>8</u>	<u>9</u>	<u>9</u>	<u>9</u>	<u>9</u>	<u>10</u>	<u>9</u>
Total	-23	-8	-12	-4	1	-16	2	5	21	-2	3	11
Deficit (-) or Surplus (NIPA basis)	-45	55	68	75	86	123	137	159	191	215	239	262

SOURCE: Congressional Budget Office.

a. Includes Social Security and the Postal Service.

b. Less than \$500 million.

Table 2-8.
Projections of Receipts and Expenditures Measured by the
National Income and Product Accounts (By fiscal year, in billions of dollars)

	Actual 1997	1998	1999	2000	2001	2002	2003	2004	2005	2006	2007	2008
Receipts												
Personal Tax and Nontax Receipts	754	835	873	890	916	958	994	1,040	1,092	1,143	1,198	1,257
Corporate Profits Tax Accruals	206	211	217	223	221	224	231	241	250	262	274	287
Indirect Business Tax and Nontax Accruals	96	93	98	99	102	106	109	110	113	115	117	120
Contributions for Social Insurance	<u>637</u>	<u>675</u>	<u>703</u>	<u>733</u>	<u>760</u>	<u>792</u>	<u>826</u>	<u>863</u>	<u>905</u>	<u>944</u>	<u>985</u>	<u>1,024</u>
Total	1,692	1,814	1,891	1,944	2,000	2,080	2,160	2,254	2,360	2,464	2,574	2,687
Expenditures												
Purchases of Goods and Services												
Defense												
Consumption	252	247	256	264	267	278	287	296	309	316	323	337
Consumption of fixed capital	57	57	56	55	55	54	54	54	54	54	54	55
Nondefense												
Consumption	137	138	149	155	160	165	171	177	182	188	194	201
Consumption of fixed capital	<u>14</u>	<u>15</u>	<u>15</u>	<u>16</u>	<u>16</u>	<u>17</u>	<u>17</u>	<u>17</u>	<u>17</u>	<u>17</u>	<u>17</u>	<u>18</u>
Subtotal	460	457	477	490	498	514	529	544	562	575	589	610
Transfer Payments												
Domestic	774	797	837	875	922	970	1,021	1,076	1,133	1,196	1,262	1,332
Foreign	<u>14</u>	<u>12</u>	<u>13</u>	<u>13</u>	<u>13</u>	<u>14</u>	<u>14</u>	<u>14</u>	<u>15</u>	<u>15</u>	<u>15</u>	<u>16</u>
Subtotal	787	809	850	888	935	984	1,035	1,090	1,148	1,211	1,277	1,347
Grants-in-Aid to State and Local Governments	221	229	250	266	278	290	304	319	335	353	374	395
Net Interest	230	231	225	217	206	194	182	172	160	148	134	120
Subsidies Less Current Surplus of Government Enterprises	38	33	34	33	34	35	36	38	39	41	42	44
Required Reductions in Discretionary Spending ^a	<u>n.a.</u>	<u>n.a.</u>	<u>-14</u>	<u>-26</u>	<u>-38</u>	<u>-60</u>	<u>-63</u>	<u>-68</u>	<u>-76</u>	<u>-78</u>	<u>-81</u>	<u>-91</u>
Total	1,737	1,759	1,823	1,869	1,914	1,957	2,023	2,095	2,169	2,249	2,335	2,425
Memorandum:												
Deficit (-) or Surplus	-45	55	68	75	86	123	137	159	191	215	239	262

SOURCE: Congressional Budget Office.

NOTE: n.a. = not applicable.

a. Unspecified reductions needed to comply with the statutory caps on discretionary spending.

accruals, and contributions for social insurance. Those labels summarize the nature of the collection and the identity of the payer. The term "nontax" indicates that NIPA receipts include some charges, such as fees and premiums, that are not generally treated as revenues in the federal budget.

Federal spending can take the form of defense and nondefense purchases (which enter directly into GDP), transfers (most of which find their way into personal income and from there into consumption or saving), grants to state and local governments (which

may end up as state and local purchases or transfers), net interest, and subsidies minus the current surplus of government enterprises such as the Postal Service and public housing authorities. Because of the discretionary spending caps that are mandated by law, required reductions in discretionary spending make up a final category. The caps will limit future spending for programs funded through the appropriation process. Although no one can predict how particular programs will fare, the deepest effects of the required reductions will almost certainly be felt in the NIPA categories of defense and nondefense purchases and grants.

The Revenue Outlook

The Congressional Budget Office estimates that federal revenues will reach \$1.7 trillion in fiscal year 1998. That will be the fifth straight year in which revenues have grown considerably faster than the country's gross domestic product, boosting them as a share of GDP to 20.5 percent—a level not reached since 1945 (see Figures 3-1 and 3-2).

In CBO's view, however, the pattern of the past five years is not sustainable over the longer term. Although CBO now projects that revenues under current law will be higher over the next decade than it estimated last March, revenue growth is expected to slow from the rapid rates of the past few years. As a result, revenues as a share of GDP will decline to 19.8 percent in 2003 and remain at about that level through 2008 (see Table 3-1). Despite the decline, that revenue share of GDP will be higher than in any year between 1945 and 1997.

In CBO's projections, revenues grow at an average annual rate of 4.5 percent through 2008, the same rate as GDP. That rate is slightly above the projected 4.3 percent average annual growth rate of wage and salary income and corporate profits combined—the sources of national income that generate the lion's share of federal revenues. In the near term, the expected cooling of the economy, the ebbing of volatile factors that have helped boost taxable incomes in recent years, and the effects of the tax reductions enacted in the Taxpayer Relief Act of 1997 are expected to slow the growth of revenues. In the longer term, the interaction of real growth in incomes and the progressivity of the tax system will cause individual in-

come taxes to rise faster than incomes, but excise taxes will grow more slowly. As a result, total revenue growth will just keep pace with growth of GDP.

Of course, revenues have at times grown faster or slower than their underlying tax bases. As explained below, previous periods in which revenue growth outpaced income growth have usually been associated with legislated increases in taxes or with rapid inflation before the inflation adjustments in the tax system, which began in 1985. The tax increases enacted in 1993 contributed to the faster revenue growth in 1994 and 1995. But as the past three years

Figure 3-1.
Federal Revenues as a Share of GDP
(By fiscal year)

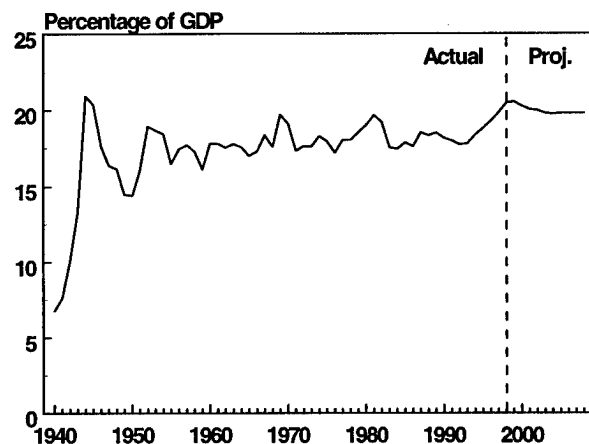

SOURCE: Congressional Budget Office.

demonstrate, revenues can grow faster than the tax base even without those conditions being present. For that trend to continue, however, factors that are likely to have boosted tax revenues—such as the surge in capital gains realizations and the jump in incomes of higher-income taxpayers—would have to continue growing at accelerated rates. That assumption is unlikely to be valid given the past patterns of change in those volatile income sources, particularly when combined with the expected waning of the boom years of the 1990s that may well have sparked their rise.

With the benefit of actual data on tax receipts reported by the Treasury for the first 10 months of the fiscal year, CBO now expects revenues to reach \$1,717 billion in 1998. That amount is \$38 billion, or 2.2 percent, higher than CBO estimated last March (based on actual receipts through January) and \$53 billion, or 3.2 percent, higher than CBO's January estimate. The size of those tax collections, which took most observers by surprise, was the major factor influencing CBO's decision to increase projected revenues in future years above the levels estimated in March.

Stronger-than-expected growth in the economy can account for just \$7 billion of the \$53 billion revenue underestimate in January, and new legislation ac-

counts for an additional \$1 billion. That leaves \$45 billion unexplained. All of that \$45 billion is associated with unexpectedly strong growth in individual income tax collections, but the particular sources of income responsible for the growth will not be known for another two years, when all the relevant tax returns have been filed and processed.

After examining the limited data available, CBO concludes that volatile sources of income, such as those associated with the recent remarkable gains in the stock market, are probably responsible for much of the recent rapid growth in individual income taxes. However, although the surge in those income sources is bound to falter, the timing of the change is uncertain. Moreover, other explanations point to factors that could spur continued growth of revenues. Faced with insufficient information, CBO has chosen a middle path and assumes that the additional 1998 revenues will continue at the same level in 1999 and beyond. Adding the same amount to revenues each year results in an increasingly smaller percentage change in projected revenues. That path, as with all revenue projections, is uncertain, particularly in the absence of complete information about the factors that have produced the recent surge in revenues.

Figure 3-2.
Annual Growth of Federal Revenues and GDP (By fiscal year)

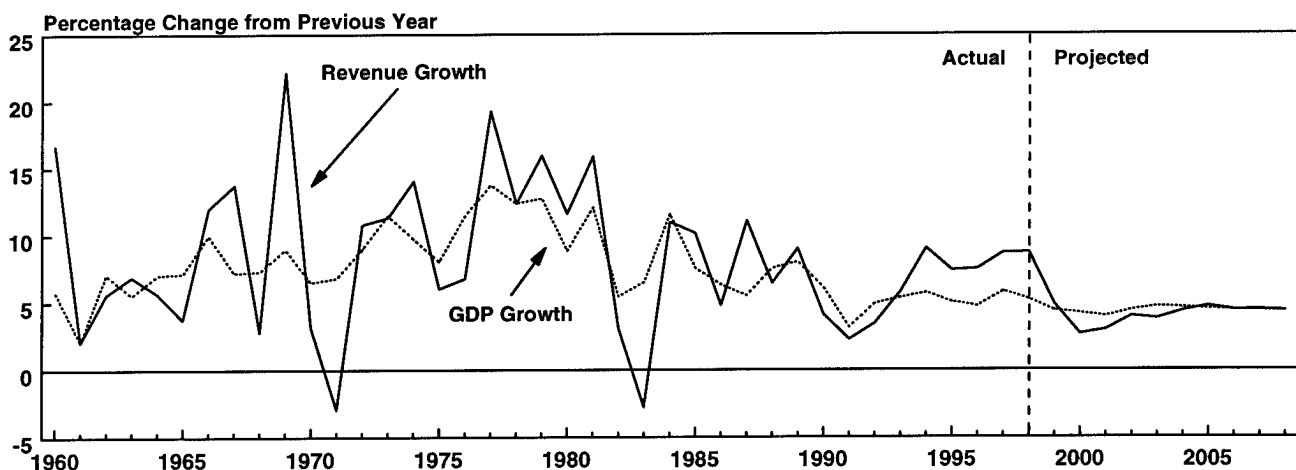

SOURCE: Congressional Budget Office.

Table 3-1.
CBO Revenue Projections (By fiscal year)

	Actual 1997	1998	1999	2000	2001	2002	2003	2004	2005	2006	2007	2008
In Billions of Dollars												
Individual Income Taxes	737	821	850	867	892	933	968	1,014	1,065	1,116	1,170	1,227
Corporate Income Taxes	182	190	196	201	201	204	210	218	228	239	250	262
Social Insurance Taxes	539	577	604	629	652	678	706	737	772	805	839	871
Excise Taxes	57	55	70	65	67	70	72	73	75	77	78	80
Estate and Gift Taxes	20	24	25	27	27	29	30	32	32	33	34	36
Customs Duties	18	18	18	19	19	21	22	23	23	24	25	26
Miscellaneous	25	31	36	41	43	44	45	46	48	49	50	51
Total	1,579	1,717	1,801	1,848	1,903	1,978	2,053	2,142	2,243	2,342	2,446	2,553
On-budget	1,187	1,296	1,359	1,388	1,425	1,481	1,534	1,601	1,675	1,750	1,829	1,911
Off-budget ^a	392	421	442	460	478	497	519	541	568	592	618	643
As a Percentage of GDP												
Individual Income Taxes	9.3	9.8	9.7	9.5	9.4	9.4	9.3	9.3	9.4	9.4	9.5	9.5
Corporate Income Taxes	2.3	2.3	2.2	2.2	2.1	2.1	2.0	2.0	2.0	2.0	2.0	2.0
Social Insurance Taxes	6.8	6.9	6.9	6.9	6.9	6.8	6.8	6.8	6.8	6.8	6.8	6.8
Excise Taxes	0.7	0.7	0.8	0.7	0.7	0.7	0.7	0.7	0.7	0.6	0.6	0.6
Estate and Gift Taxes	0.2	0.3	0.3	0.3	0.3	0.3	0.3	0.3	0.3	0.3	0.3	0.3
Customs Duties	0.2	0.2	0.2	0.2	0.2	0.2	0.2	0.2	0.2	0.2	0.2	0.2
Miscellaneous	0.3	0.4	0.4	0.4	0.5	0.4	0.4	0.4	0.4	0.4	0.4	0.4
Total	19.8	20.5	20.6	20.3	20.1	20.0	19.8	19.8	19.8	19.8	19.8	19.8
On-budget	14.9	15.4	15.5	15.2	15.0	15.0	14.8	14.8	14.8	14.8	14.8	14.8
Off-budget ^a	4.9	5.0	5.0	5.0	5.0	5.0	5.0	5.0	5.0	5.0	5.0	5.0

SOURCE: Congressional Budget Office.

a. Social Security.

Key Factors in Projecting Revenues

Every baseline revenue projection begins with the Congressional Budget Office's forecast for the economic variables in the national income and product accounts and for key indicators of labor and financial markets. Those variables include gross domestic product, taxable income, employment, and inflation.

The most important inputs for baseline revenue projections are the forecasts for growth in wage and salary income and corporate profits. Those sources of

income largely determine the tax base for individual income taxes, social insurance payroll taxes, and corporate income taxes, which together account for about 90 percent of federal revenues. The projection for the rate of inflation is also important because it determines the indexing adjustment for exemptions, deductions, credits, and tax brackets in the individual income tax. For the same projected nominal income, a higher projected rate of inflation will result in a lower estimate of income tax revenues.

Some sources of taxable income do not have a counterpart in the NIPAs and thus are not projected as part of CBO's economic forecast. Those sources, which must be estimated separately, include capital

gains realizations and distributions from pensions, 401(k) plans, and individual retirement accounts (IRAs). CBO must also make separate estimates for many other items, including the growth in both adjustments to income (such as IRA contributions) and itemized deductions. Having constructed the database for the projection year, CBO estimates tax liabilities using a detailed model of the tax rules for that year.

For all revenue sources, the next step after determining liabilities is to estimate the payments based on those liabilities. In the case of certain excise taxes, payment schedules are known, and the payment of those liabilities is quite predictable. In the case of income taxes, however, taxpayers have some discretion (within legal limits) about when and in what form to pay those liabilities. Analysts must estimate how much of the individual income tax liability incurred in a particular calendar year will show up as payments in the concurrent fiscal year (either through withholding or through quarterly estimated payments) and how much will show up as final payments in April of the following year. Analysts must also estimate the payment pattern of corporations.

Actual revenues can thus differ from projected revenues for a number of reasons. First, the historical economic data that are the starting point for the projections are themselves subject to revision. In addition, the economic forecast may turn out to be higher or lower than actual outcomes, and income reported on tax returns may grow at different rates than those forecast for aggregate economic variables. The projections for other economic variables that are not reported in the NIPAs may also be off the mark. Even if the overall growth rate is forecast accurately, some sources of income may grow at different rates for different taxpayers, which could affect tax liabilities; for example, faster-than-average income growth for higher-income taxpayers will boost revenues because higher income is taxed at higher rates. Finally, the timing of tax payments may differ from what was expected.

Revenues in 1998

Based on information through July, revenues in fiscal year 1998 will most likely be \$53 billion higher than

the \$1,665 billion estimated last January (see Table 3-2). An underestimate of individual income tax receipts accounts for almost all of that discrepancy. Projections of the other sources of revenues were close to the mark. Corporate income taxes appear to be somewhat lower than expected and social insurance taxes somewhat higher, but those two forecasting errors are offsetting. In both cases, the difference between the January estimate and the current estimate is attributable to small forecasting errors in the relevant components of taxable income—corporate profits and wages.

The underestimate in the forecast of wages and salaries, however, can account for only \$8 billion of the expected \$53 billion underestimate of individual income tax receipts. One must look elsewhere for the source of the remaining \$45 billion.

Data on collections so far this year indicate that the additional individual income tax revenue came from taxes owed on both 1997 and 1998 incomes.

Table 3-2.
Comparison of CBO's July and January 1998
Projections of Federal Revenues for
Fiscal Year 1998 (In billions of dollars)

Source	CBO's Projections		Difference
	July 1998	January 1998	
Individual Income Taxes			
Withheld	636	614	22
Nonwithheld	284	255	29
Refunds	<u>-99</u>	<u>-101</u>	<u>2</u>
Subtotal	821	768	53
Corporate Income Taxes	190	197	-7
Social Insurance Taxes	577	573	5
Excise Taxes	55	55	0
All Other Revenue Sources	<u>74</u>	<u>72</u>	<u>1</u>
Total	1,717	1,665	53

SOURCE: Congressional Budget Office.

About one-third of the unexplained increase was in final payments in April, which reflect tax liabilities on income received in calendar year 1997; one-third was in higher-than-expected withholding on 1998 incomes; and the other one-third was in higher-than-expected estimated tax payments on 1998 liabilities, which are also based on 1998 incomes. Because the additional revenues have come from liabilities for both 1997 and 1998 and because the additional payments on 1998 liabilities include both withheld and nonwithheld taxes, a number of factors are likely to have contributed to CBO's underestimate in January.

The available data, however, provide virtually no information about the income that generated those tax collections. A well-founded explanation of the unexpected revenues would require detailed information from tax returns about the particular sources of income and other factors that generated tax liabilities in calendar years 1997 and 1998. But such information is available only through 1996. Because many taxpayers, especially those with high incomes, file for extensions beyond the April 15 filing date, sufficient data on 1997 incomes and tax liabilities will not be available until late this year, after returns filed in August and October have been processed. Data on 1998 liabilities will not be available until late 1999.

Evidence from Prior Years

This year is likely to be the third in a row in which actual revenues have exceeded the amount CBO estimated in its winter baseline projections. Some of the explanations for the additional revenues in the previous two years could apply to the additional revenues in 1998.

In January 1997, CBO underestimated tax liabilities for 1996 by about \$25 billion, even though NIPA incomes for most of the year were known at that point. Two factors account for that underestimate. First, estimates of income growth in 1996 based on incomes that were originally reported in the NIPAs turned out to be too low. Later revisions that the Department of Commerce made to reported incomes raised the estimated growth rate. The revised figures for 1996 would have generated an additional \$5 billion

in revenues had those estimates been used instead of the originally reported estimates.

Second, there were a number of differences between projected incomes and deductions and the data later reported on 1996 tax returns. For example, income from partnerships and Subchapter S corporations, which is highly concentrated among high-income taxpayers and thus taxed at higher-than-average tax rates, rose 18 percent in 1996—much faster than projected. Wages and salaries for high-income taxpayers grew faster than average, boosting liabilities by almost \$3 billion compared with what they would have been if all wages had risen at the average rate. The growth in deductions, which was projected to keep pace with income growth, lagged behind incomes. And pension income and distributions from IRAs and 401(k) plans grew faster than projected.

Unexpectedly high realizations of capital gains in calendar year 1996, on which taxes were paid primarily in January and April of 1997, contributed about \$15 billion in additional revenues. Taxable capital gains realizations grew by 45 percent between 1995 and 1996—a growth rate exceeded only twice during the past 40 years, in 1979 and 1986 (see Figure 3-3).

Figure 3-3.
Annual Growth of Taxable Capital Gains Realizations (By calendar year)

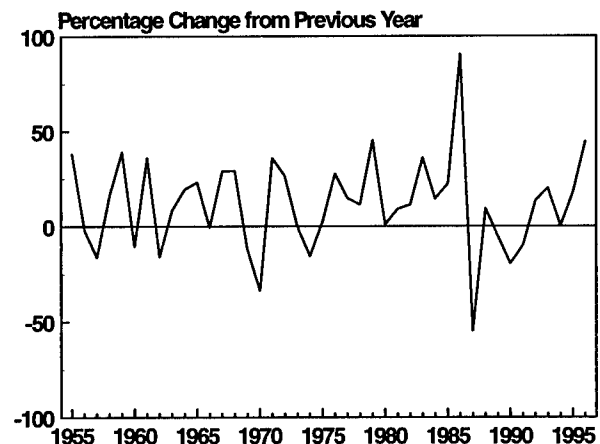

SOURCE: Congressional Budget Office.

NOTES: The spike in 1986—and the decline in 1987—occurred because taxpayers rushed to realize capital gains before an increase in the tax rate took effect in 1987.

That growth was all the more extraordinary because the tax rate on capital gains did not change between 1995 and 1996. If anything, taxpayers in 1996 might have anticipated a future rate reduction, giving them an incentive to defer realizations of past gains until the tax cut was enacted.

How should knowledge about the sources of growth in liabilities in 1996 be used in projecting future revenues? The answer depends on which of the factors at work in 1996 have continued into 1998 and whether and to what extent they will continue in the future. If incomes in 1997 and 1998 turn out to be higher than has been reported in the NIPA data, that discrepancy might produce an effect that grows over time at roughly the rate of the projected growth in incomes. The incomes of high-income taxpayers could continue to rise more rapidly than average incomes, but they could also grow at the same rate or more slowly, producing a constant or declining effect on future revenues. An increase in realizations of deferred income that has accumulated over a number of years—such as capital gains—is often a temporary phenomenon, although the tax cuts enacted in 1997 provided an additional boost to realizations as taxpayers responded to the lower tax rate on gains. Unless there is a change in tax law, realizations will probably not continue to grow at their recent high rate, except in the unlikely event that the stock market repeats its remarkable performance of recent years.

One source of the underestimate in 1996 seems likely to have continued into 1997 and may contribute to growing amounts of revenue in the future. In recent years, the growth rate of pension payouts and withdrawals from 401(k)s and individual retirement accounts has exceeded CBO's estimates. Contributions to 401(k)s and IRAs grew rapidly in the 1980s, and assets in those accounts accumulated as the stock market soared. The result is that withdrawals have been growing in the 1990s.

After assessing the possible alternatives, CBO has assumed that, on balance, the factors likely to have boosted incomes and tax revenues in recent years will neither continue to grow at the same pace nor rapidly fade away. Thus, the additional revenues in 1998 have been projected to continue over the next decade at their 1998 level. That assumption, along with small changes resulting from other adjustments, generates

the technical changes to revenues discussed in Chapter 2. CBO will reevaluate that assumption for next winter's baseline using the data about 1997 taxable incomes that will become available at the end of this year and taking into account the 1998 revisions to the NIPA statistics.

Several changes in tax provisions in 1998 had only a small effect on revenues. The Internal Revenue Service Restructuring and Reform Act of 1998 will add about \$1 billion to corporate income tax revenue in 1998. The Congress did not extend several revenue-reducing tax provisions before they expired on June 30, 1998, but that did not result in higher projected revenues for 1998 in the current baseline because CBO's winter projections assumed their expiration. The expired provisions are the credit for research and experimentation, the Generalized System of Preferences program, the work opportunity tax credit, a nonconventional fuels credit, and a provision that affects allowable deductions for gifts made to private foundations.

Revenue Estimates for 1999 and 2000

CBO expects growth in revenues to outpace growth in GDP in 1999, pushing the revenue share of GDP to 20.6 percent. But the rate at which revenues grow will slow considerably. Total revenues are likely to increase by 8.7 percent in 1998 but by only 4.9 percent in 1999 and 2.6 percent in 2000 (see Table 3-3).

All three of the major revenue sources—individual and corporate income taxes and social insurance taxes—contribute to the slowdown in revenue growth projected for 1999. That drop is attributable in part to economic factors. The growth in the sum of wages and profits is projected to fall to 4.1 percent in 1999, down from 6.5 percent in 1998. In recent years, those incomes have grown more rapidly than GDP, contributing to the increase in taxes as a share of GDP. But in 1999, incomes and GDP are projected to grow at about the same rate (see Figure 3-4).

The rest of the drop in the growth rate of revenues comes from CBO's assumption that the factors

that produced the unexpected revenues in 1998 will add about the same dollar amount to revenues in 1999 as they did in 1998. If, instead, that effect actually grows, revenues will rise at a faster rate. However, if it turns out that the additional revenues resulted largely from temporary factors in 1998, the growth rate of revenues may decline even more precipitously than projected in 1999.

The growth rate of individual income taxes is expected to fall sharply between 1998 and 1999, from 11.3 percent to 3.6 percent. The expected cooling of the economy, the assumption that the unexpected revenue in 1998 will continue at its 1998 level rather than grow, and provisions in the Taxpayer Relief Act of 1997 will all contribute to the slowdown.

Table 3-3.
Revenues, by Source, Since Fiscal Year 1985

Fiscal Year	Individual Income Taxes			Corporate Income Taxes	Social Insurance Taxes and Contributions	Excise Taxes and All Other Reve- nue Sources	Total Revenues
	Withheld	Nonwithheld	Total ^a				
In Billions of Dollars							
1985	299	101	335	61	265	73	734
1986	315	106	349	63	284	73	769
1987	322	143	393	84	303	75	854
1988	341	132	401	95	334	79	909
1989	361	155	446	103	359	83	991
1990	388	151	467	94	380	92	1,032
1991	404	143	468	98	396	93	1,055
1992	408	149	476	100	414	101	1,091
1993	430	155	510	118	428	99	1,154
1994	460	160	543	140	461	114	1,259
1995	500	176	590	157	484	120	1,352
1996	533	212	656	172	509	115	1,453
1997	580	251	737	182	539	120	1,579
1998 ^b	636	284	821	190	577	129	1,717
1999 ^b	673	300	850	196	604	150	1,801
2000 ^b	698	299	867	201	629	152	1,848
Percentage Change from Previous Year							
1986	5.3	4.6	4.3	3.0	7.1	0.2	4.8
1987	2.4	34.9	12.5	32.9	6.8	1.8	11.1
1988	5.9	-7.5	2.2	12.6	10.2	6.3	6.4
1989	5.8	17.1	11.1	9.3	7.5	4.4	9.0
1990	7.5	-2.3	4.8	-9.5	5.7	10.6	4.1
1991	4.1	-5.7	0.2	4.9	4.2	1.7	2.2
1992	1.0	4.7	1.7	2.2	4.5	8.9	3.4
1993	5.4	3.6	7.1	17.2	3.5	-2.4	5.8
1994	6.8	3.4	6.5	19.5	7.7	15.0	9.0
1995	8.7	9.8	8.7	11.8	5.0	5.6	7.4
1996	6.6	20.7	11.2	9.4	5.1	-3.9	7.5
1997	8.8	18.2	12.3	6.1	5.9	4.1	8.7
1998 ^b	9.7	13.1	11.3	4.3	7.0	7.2	8.7
1999 ^b	5.8	5.6	3.6	3.2	4.6	16.5	4.9
2000 ^b	3.7	c	1.9	2.5	4.1	1.0	2.6

SOURCE: Congressional Budget Office.

a. Because it includes tax refunds, this total is less than the sum of withheld and nonwithheld individual income taxes.

b. Projected.

c. Less than 0.05 percent.

As the economy slows, wage growth is projected to fall from 7.1 percent to 4.6 percent. The growth in the amount of income taxes withheld from people's paychecks—an amount that is based largely on the level of wages and salaries—should slow even more because there will be less “real bracket creep.” Even when the tax system is indexed for inflation, bracket creep occurs when real wages are increasing, because the tax rate on additional wages is higher than the average tax rate on wages. A taxpayer in the 28 percent bracket, for example, will have all additional wage growth in excess of inflation taxed at 28 percent. Because of personal exemptions, the standard deduction, and the 15 percent bracket, the tax on that taxpayer's total wages is less than 28 percent. Under the current individual income tax system, revenues increase by about 1.5 percentage points for each percentage point that the growth in income per taxpayer exceeds the inflation rate. Thus, slower wage growth will lead to a more-than-commensurate slowdown in withheld taxes.

The Taxpayer Relief Act alone lowers the projected growth rate of individual income taxes by nearly 3 percentage points. The first payouts of the child and education credits enacted in 1997 are expected to increase refunds by about 25 percent between 1998 and 1999. The act, however, has little effect on the overall

growth rate of revenues. A shift of about \$7 billion in excise tax payments from August and September 1998 to October 1998, as permitted by the act, should boost excise tax revenue in 1999, offsetting most of the reduction in individual income taxes.

The weak projected growth of revenues in 2000 results from several factors. The sum of wages and profits is projected to grow even more slowly in 2000—by just 3.8 percent. In addition, the Taxpayer Relief Act is expected to shave about 1 percentage point from the growth of total revenues. Projected individual income taxes in 2000 reflect the expectation that some recipients of the new child and education credits will adjust their withholding rates after they receive large refunds in the spring of 1999, dampening the growth in withheld taxes.

The Longer-Term Revenue Outlook

Unless tax laws change, revenues will continue to be historically high as a percentage of GDP for the next 10 years. CBO expects that to be the case despite last year's tax cuts, which will lower revenues by about 0.3 percent of GDP in 2000 and later years. Under baseline assumptions, CBO projects that total revenues as a share of GDP will decline only slightly, from 20.3 percent of GDP in 2000 to 19.8 percent in 2008. The projections assume that provisions scheduled to expire in 1999 and later years will do so as specified in current law. In keeping with baseline rules spelled out in the Balanced Budget and Emergency Deficit Control Act of 1985, however, the projections assume that excise taxes dedicated to trust funds will be extended before they expire.

Some striking shifts have occurred in the composition of revenues since 1960 (see Figure 3-5). One of the most visible shifts is the government's increasing reliance on receipts from social insurance taxes (now about 7 percent of GDP), which are largely generated by the payroll taxes that fund Social Security and Medicare's Hospital Insurance program. Legislation during that period has expanded the payroll tax base and raised the payroll tax rate. Another change is the government's diminishing reliance on receipts from

Figure 3-4.
Annual Growth of Income and GDP
(By fiscal year)

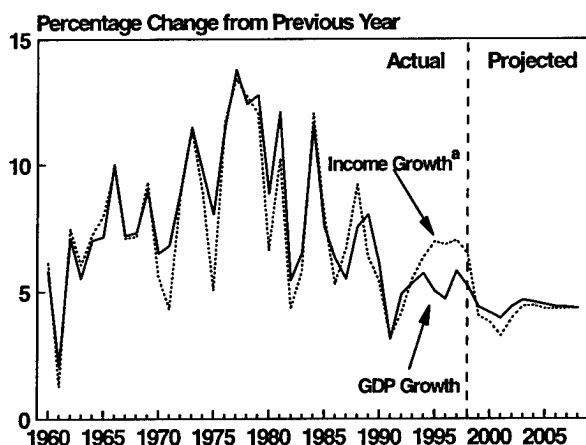

SOURCE: Congressional Budget Office.

a. Income is defined as wages and salaries plus corporate profits.

corporate income taxes and excise taxes (now about 2 percent and 1 percent of GDP, respectively). Individual income tax receipts, which contribute the most to government coffers, have fluctuated in the range of 8 percent to 9 percent of GDP for three decades, but they are likely to hit their highest level ever—9.8 percent—in 1998. The two earlier peaks occurred in 1969, when revenues were boosted by a temporary surcharge to finance the Vietnam War, and in 1981, when revenues were pushed up because several years of high inflation had moved many people into higher tax brackets.

Although revenues will increase more slowly than in past decades, they will grow slightly faster

than incomes over the 1998-2008 period. From 1959 through 1997, revenues increased at an average annual rate of 8.2 percent, compared with 7.6 percent for GDP and 7.4 percent for wages and profits (see Table 3-4). Most of the revenue growth in excess of income growth came about because of legislated increases in payroll taxes, which rose at an average annual rate of 10.6 percent over that period compared with 7.5 percent for all other taxes. With income growth expected to slow from the rates of past decades for reasons discussed in Chapter 1 (including much slower growth in the labor force, slower growth in productivity than in the 1960s, and much lower inflation than in the 1970s and 1980s), revenue growth must also slow.

Figure 3-5.
Revenues, by Source, as a Share of GDP (By fiscal year)

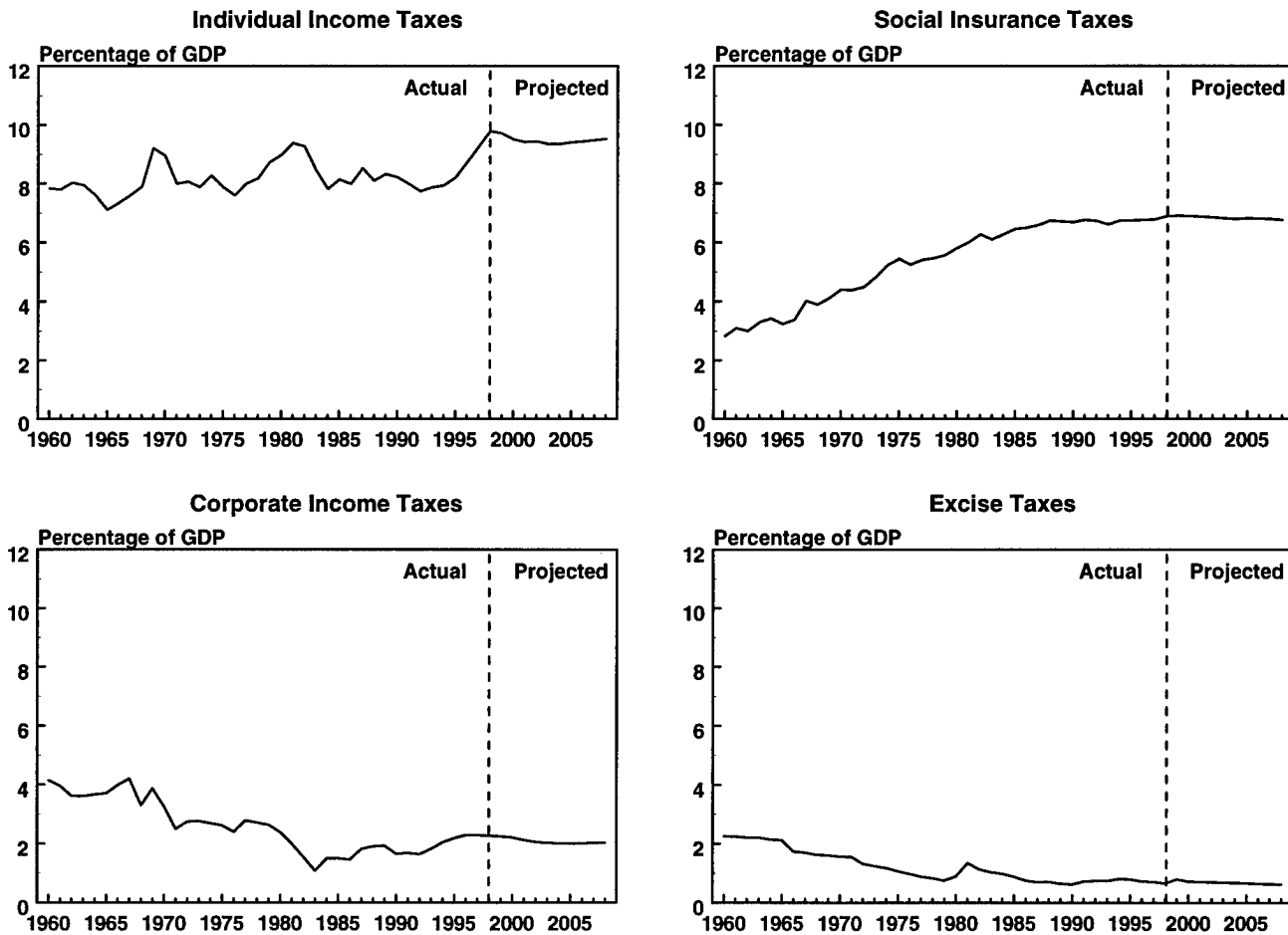

SOURCE: Congressional Budget Office.

Individual Income Taxes

Individual income tax receipts are projected to decline from 9.8 percent of GDP in 1998 to 9.3 percent in 2003 (see Table 3-5). A significant factor is that taxable capital gains realizations are projected to return to levels more consistent with the size of the economy and the current tax rate on gains. CBO expects the growth of the stock market to subside and the response to last year's cut in the tax rate on gains to be smaller after the first year, which in turn will cause capital gains tax receipts to rise more slowly than GDP between 1997 and 2003.

After 2004, individual income tax receipts should begin a slow, steady climb as a share of GDP, despite a decline in taxable personal income as a share of GDP. Even when tax law is unchanged, individual receipts tend to rise over time as a share of taxable personal income because income growth above the rate of inflation causes more income to be taxed at higher rates.

Corporate Income Taxes

CBO projects that corporate income tax receipts will decline as a share of GDP over the next five years, dropping from 2.3 percent in 1998 to 2.0 percent in 2003. Receipts as a share of GDP will fall as rising labor costs depress taxable corporate profits' share of GDP (see Table 3-5). That share is projected to fall from 6.8 percent of GDP, which is unusually high, to 6.0 percent in 2003.

The average effective corporate tax rate is projected to rise slightly in the next few years. The recent expiration of the tax credit for research and experimentation and the expiration of several other credits in the next few years will lead to a higher effective rate. In addition, total corporate profits are forecast to grow relatively slowly, with the result that more companies can be expected to generate losses. In general, firms cannot use all of those losses to reduce tax liabilities, because the corporate income tax does not treat gains and losses symmetrically. To the extent that such

Table 3-4.
Average Annual Growth Rates of Income and Revenues for 1959-1997 and Projected Through 2008
(By fiscal year, in percent)

	Historical					Projected 1997-2008
	1959-1969	1969-1979	1979-1989	1989-1997	1959-1997	
Income						
Nominal GDP	6.8	10.2	7.9	5.1	7.6	4.5
Wages, Salaries, and Corporate Profits	6.9	9.4	7.4	5.7	7.4	4.3
Revenue						
Federal Revenues	9.0	9.5	7.9	6.0	8.2	4.5
Social Insurance	12.8	13.5	10.0	5.2	10.6	4.5
Other Taxes	8.2	8.2	6.9	6.4	7.5	4.5
Income taxes	8.7	8.6	6.8	6.7	7.7	4.5
Excise and other	5.9	5.5	7.3	4.8	5.9	4.4

SOURCE: Congressional Budget Office.

Table 3-5.
CBO Projections for Individual, Corporate, and Social Insurance Receipts
and Their Tax Bases (By fiscal year)

	Actual 1997	1998	1999	2000	2001	2002	2003	2004	2005	2006	2007	2008
Individual Income Tax Receipts and Tax Base												
Individual Income Tax Receipts												
In billions of dollars	737	821	850	867	892	933	968	1,014	1,065	1,116	1,170	1,227
As a percentage of GDP	9.3	9.8	9.7	9.5	9.4	9.4	9.3	9.3	9.4	9.4	9.5	9.5
Taxable Personal Income												
In billions of dollars	5,573	5,914	6,180	6,410	6,635	6,902	7,200	7,509	7,824	8,148	8,485	8,837
As a percentage of GDP	69.9	70.5	70.6	70.2	70.0	69.7	69.4	69.2	69.0	68.8	68.7	68.5
Individual Receipts as a Percentage of Taxable Personal Income	13.2	13.9	13.8	13.5	13.5	13.5	13.5	13.5	13.6	13.7	13.8	13.9
Corporate Income Tax Receipts and Tax Base												
Corporate Income Tax Receipts												
In billions of dollars	182	190	196	201	201	204	210	218	228	239	250	262
As a percentage of GDP	2.3	2.3	2.2	2.2	2.1	2.1	2.0	2.0	2.0	2.0	2.0	2.0
Corporate Profits												
In billions of dollars	787	817	828	846	843	856	886	921	954	990	1,030	1,075
As a percentage of GDP	9.9	9.7	9.4	9.3	8.9	8.6	8.5	8.5	8.4	8.4	8.3	8.3
Taxable Corporate Profits ^a												
In billions of dollars	554	568	581	594	593	604	627	656	684	717	752	790
As a percentage of GDP	7.0	6.8	6.6	6.5	6.3	6.1	6.0	6.1	6.0	6.1	6.1	6.1
Corporate Receipts as a Percentage of Taxable Profits	32.9	33.5	33.8	33.8	33.9	33.8	33.4	33.2	33.3	33.3	33.2	33.1
Social Insurance Tax Receipts and Tax Base												
Social Insurance Tax Receipts												
In billions of dollars	539	577	604	629	652	678	706	737	772	805	839	871
As a percentage of GDP	6.8	6.9	6.9	6.9	6.9	6.8	6.8	6.8	6.8	6.8	6.8	6.8
Wages and Salaries												
In billions of dollars	3,812	4,080	4,269	4,445	4,621	4,824	5,046	5,276	5,512	5,754	6,007	6,269
As a percentage of GDP	47.8	48.6	48.7	48.7	48.7	48.7	48.7	48.6	48.6	48.6	48.6	48.6
Social Insurance Receipts as a Percentage of Wages and Salaries	14.2	14.1	14.1	14.1	14.1	14.1	14.0	14.0	14.0	14.0	14.0	13.9

SOURCE: Congressional Budget Office.

NOTE: The tax bases in this table reflect income as measured by the national income and product accounts rather than as reported on tax returns.

a. Taxable corporate profits are defined as economic profits net of the adjustments for capital consumption and inventory valuation; profits earned by the Federal Reserve System, transnational corporations, and S corporations; and payments of state and local corporate taxes. They include capital gains realized by corporations.

losses reduce total profits without a proportionate reduction in total tax payments, the average tax rate on profits rises.

Beyond 2003, corporate income tax receipts will maintain their share of GDP, CBO projects. Neither taxable profits as a share of GDP nor the average tax rate is expected to change significantly.

Social Insurance Taxes

CBO expects social insurance tax receipts to track GDP closely over the next decade (see Table 3-5). Wages and salaries are expected to maintain their 1998 share of GDP through 2008. Over that period, social insurance receipts will decline slightly as a percentage of wages and salaries and as a percentage of GDP. The decline is largely attributable to two factors. One is the projected steady erosion of unemployment insurance receipts as states lower unemployment insurance tax rates in response to current low claims and the resulting growth in the trust fund balances. The other factor is a continuation of the slight downward trend in the fraction of wages subject to Social

Security taxes. The scheduled expiration of the 0.2 percent surtax in the federal unemployment tax in 2008 will cause a slightly larger dip that year.

Excise Taxes

Excise taxes, a smaller source of revenues, are expected to continue their long-term decline as a share of GDP, falling to just over 0.6 percent by 2008 from their 1997 level of 0.7 percent. Most excise taxes—those representing about 80 percent of total excise revenues—are levied per unit of good or per transaction rather than as a percentage of value. Thus, they do not grow in tandem with nominal incomes.

Excise taxes were increased by tax legislation in 1997. The Taxpayer Relief Act restored aviation taxes (which were about to expire) and raised them slightly. In addition, the Balanced Budget Act of 1997 boosted cigarette taxes. Those changes moderate the long-term decline in excise tax receipts. The baseline for 2008 includes \$21 billion from excise taxes that are scheduled to expire before then but are assumed to be extended.

Appendixes

Evaluating CBO's Record of Economic Forecasts

Since issuing its first forecast in 1976, the Congressional Budget Office has compiled a record of economic predictions that compares favorably with the track records of five Administrations and the consensus forecasts of a sizable sample of private-sector economists. Although the margin is slight, CBO's forecasts have generally been closer than the Administration's to the actual values of several economic indicators that are important for projecting the budget. Moreover, during the 15 years for which comparisons are possible, CBO's forecasts have been about as accurate as the average of the 50 or so forecasts that make up the *Blue Chip* consensus survey. Comparing CBO's forecasts with that survey suggests that when CBO's economic predictions missed the mark by a margin wide enough to contribute to sizable misestimates of the deficit or surplus, those errors probably reflected limitations that confronted all forecasters.

Those conclusions echo the findings of previous studies published by the Congressional Budget Office and other government and academic reviewers. They emerge from an evaluation of the accuracy of short-term forecasts for four economic indicators: growth in real (inflation-adjusted) output, inflation in the consumer price index (CPI), interest rates on three-month Treasury bills in both nominal and real terms, and interest rates on 10-year Treasury notes and Aaa corporate bonds. In carrying out that evaluation, CBO compiled two-year averages of its forecasts for the four indicators and compared them with historical values as well as with the corresponding forecasts of the

Administration and the *Blue Chip* consensus. CBO also examined a measure of taxable incomes and compared it with the Administration's forecasts.

Overall, the average errors in the Administration's two-year forecasts were slightly greater than in CBO's. Both CBO and the Administration have tended to err on the side of optimism in their output forecasts for the 1976-1997 period. The average forecast error for real growth was an overestimate, but the more recent forecasts have turned out to be pessimistic. On average, CBO has tended to neither overestimate nor underestimate inflation, whereas the Administration's average error for inflation has been a slight underestimate. The Administration has been more optimistic than CBO in forecasting nominal interest rates. Finally, CBO's forecasts appear to be about as accurate as those of the *Blue Chip* consensus over the period for which comparable *Blue Chip* forecasts are available (1982-1996).

CBO's and the Administration's longer-term (five-year) projections of average growth in real output were generally optimistic. CBO's errors were usually much smaller than the Administration's, however, no larger on average than those in its two-year forecasts of real output. Again, CBO's projections were about as accurate as those of the *Blue Chip* consensus over the comparable period (1979-1993).

The differences among the three forecasts, however, are not large enough to be statistically signifi-

cant. The small number of forecasts available for analysis makes it difficult to distinguish meaningful differences in their performance from those that might arise randomly. The statistics presented here should not be construed as reliable indicators of the future performance of any of the forecasters.

Sources of Data for the Evaluation

Evaluating CBO's forecasting record requires compiling the basic historical and forecast data for growth in real output, CPI inflation, interest rates, and taxable incomes. Although each of those series has an important influence on budget projections, an accurate forecast of the two-year average growth in real output is the most critical economic factor in accurately estimating the deficit or surplus for the upcoming budget year. Two-year average forecasts published in early 1997 and 1998 could not be included in this evaluation because historical values for 1998 and 1999 are, of course, not yet available. The data were therefore compiled using forecasts published early in the years 1976 through 1996.

Selection of Historical Data

Which historical data to use for the evaluation was dictated by the availability of actual data and the nature of the individual forecasts examined. Although CBO, the Administration, and *Blue Chip* all published the same measure for real output growth, selecting a historical series was difficult because of periodic benchmark revisions in the actual data.¹ By comparison, not all of the forecasters published the same measures for CPI inflation and interest rates, but the selection of historical data for those series was clear-cut.

Growth in Real Output. Historical two-year averages of growth in real output were developed from

calendar year averages of the quarterly chain-type annual-weighted indexes of real gross national product (GNP) and real gross domestic product (GDP) published by the Bureau of Economic Analysis (BEA). The fact that several real GNP and GDP series were discontinued because of periodic benchmark revisions meant that they were unsuitable historical series. For example, during the 1976-1985 period, the three forecasters published estimates for a measure of growth in real GNP that was based on 1972 prices, which was the measure published by BEA at the time. In late 1985, however, BEA discontinued the 1972-dollar series and began to publish GNP on a 1982-dollar basis. As a result, an official series of values for GNP growth in 1972 dollars is not available for the years after 1984; thus, actual two-year average growth rates are not available to compare with the forecasts made in early 1984 and 1985.

From 1986 to 1991, forecasters published estimates of growth in real GNP based on 1982 prices. BEA revised the benchmark again in the second half of 1991; it discontinued the 1982-dollar GNP and began to publish GNP on a 1987-dollar basis.² Consequently, the historical annual series for 1982-dollar GNP is available only through 1990, and actual two-year average growth rates are not available for the forecasts made in early 1990 and 1991. The forecasters then published estimates of growth in real GDP on a 1987-dollar basis until 1995, when BEA made another switch, late in the year, to a chain-weighted measure of GDP. Therefore, the historical annual series for 1987-dollar GDP ends with the 1994 annual value, and actual two-year average growth rates are not available for the forecasts made in early 1994 and 1995.

By periodically updating the series to reflect more recent prices, BEA's benchmark revisions yield a measure of real output that is more relevant for analyzing contemporary movements in real growth. But the process makes it difficult to evaluate forecasts of real growth produced over a period of years for series that are subsequently discontinued. The difficulties presented by periodic revisions of the data are avoided here by using one of BEA's alternative measures of

1. Before 1992, CBO, the Office of Management and Budget, and *Blue Chip* used gross national product to measure output. Beginning in early 1992, however, all three forecasters began to publish forecasts and projections of gross domestic product instead.

2. As of the 1992 benchmark revision, GDP replaced GNP as the central measure of national output.

real GNP and GDP, the chain-type annual-weighted index.³

CPI Inflation. Two-year averages of inflation in the consumer price index were calculated from calendar year averages of monthly data published by the Bureau of Labor Statistics. Before 1978, the bureau published only one consumer price index series, now known as the CPI-W (the price index for urban wage earners and clerical workers). In January 1978, however, it began to publish a second, broader consumer price index series, the CPI-U (the price index for all urban consumers). CBO's comparison of forecasts used both series.

Until 1992, the Administration published its forecasts for the CPI-W, the measure used to index most of the federal government's expenditures for entitlement programs. By contrast, for all but four of its forecasts since 1979 (1986 through 1989), CBO based its inflation forecast on the CPI-U, a more widely cited measure of inflation and the one now used to index federal income tax brackets. The *Blue Chip* consensus has always published its forecast of the CPI-U. Although both the CPI-U and CPI-W may be forecast with the same relative ease, and annual fluctuations in the two series are virtually indistinguishable, they differ in some years. For that reason, CBO used historical data for both series to evaluate the alternative forecast records.

Interest Rates. Two-year averages of nominal short- and long-term interest rates were developed from calendar year averages of monthly data published by the Board of Governors of the Federal Reserve System.

The forecasts of short-term interest rates were compared using historical values for two measures of the interest rate on three-month Treasury bills: the new-issue rate and the secondary-market rate. The Administration forecasts the new-issue rate, which corresponds to the price of three-month bills auctioned by the Treasury Department—that is, it reflects the interest actually paid on that debt. CBO forecasts the secondary-market rate, which corresponds to the price of the three-month bills traded outside the Treasury

auctions. Because such transactions occur continually in markets that involve many more traders than do Treasury auctions, the secondary-market rate provides an updated evaluation of the short-term federal debt by the wider financial community. *Blue Chip* has alternated between those two rates; it published the new-issue rate from 1982 to 1985, switched to the secondary-market rate during the 1986-1991 period, and then returned to the new-issue rate in 1992. Clearly, there is no reason to expect the two rates to differ persistently; indeed, the differences between their calendar year averages are minuscule.

The Congressional Budget Office likewise compared the various forecasts of long-term interest rates using historical values for two measures of long-term rates: the 10-year Treasury note rate and Moody's Aaa corporate bond rate. A comparison of forecasts is not possible before 1984 because not all of the forecasters published projections of long-term interest rates before that year. For forecasts made in early 1984 and 1985, CBO projected the Aaa corporate bond rate. Beginning with its early 1986 forecast, however, CBO switched to the 10-year Treasury note rate. The Administration has always published its projection for the 10-year Treasury note rate, but *Blue Chip* has published the Aaa corporate bond rate.

CBO calculated separate historical values for real short-term interest rates using the nominal short-term interest rate and inflation rate appropriate for each forecaster. In each case, the two-year average nominal interest rate was discounted by the two-year average rate of inflation. The resulting real short-term interest rates were very similar. Because there is no agreed-upon method for calculating real long-term interest rates, they were not included in the evaluation.

Taxable Income. Through its influence on the projection for federal revenues, the forecast for taxable income plays a critical role in determining the accuracy of the deficit projection. The income measure examined here—wage and salary distributions plus the book value of corporate profits—combines the two sources of income to which tax receipts are most sensitive. Because the effective rates of tax on wages (including payroll and income taxes) and corporate profits are nearly the same and because those tax rates exceed the rate at which other income sources (such as

3. For a discussion of this index, see Congressional Budget Office, *The Economic and Budget Outlook: An Update* (August 1995), pp. 71-73.

interest income) are taxed, it is appropriate to consider wages and profits together.

Although the level of taxable income is the factor that most directly affects federal revenues, historical estimates of the levels of income are subject to substantial statistical revision. As a result, using the *levels* of taxable income would distort the forecast comparison. Instead, the forecasts are presented here as *changes* in taxable income as a share of total income; the historical revisions, carried forward consistently to projections, should not affect projections of revenues. Moreover, the shares formulation is closer to the concept that macroeconomists consider when they construct their forecasts.

Sources of Forecast Data

With the exception of the measures of taxable income, the evaluation used calendar year forecasts and projections—which CBO has published early each year since 1976—timed to coincide with the publication of the Administration's budget proposals. The Administration's forecasts were taken from its budget in all but one case; the forecast made in early 1981 came from the Reagan Administration's revisions of President Carter's last budget. The corresponding CBO forecast was taken from CBO's published analysis of President Reagan's budget proposals. That forecast did not include the economic effects of the new Administration's fiscal policy proposals.⁴

The average two-year forecasts of the *Blue Chip* consensus survey, which are published monthly, were taken from those published in the same month as CBO's forecasts. Because the *Blue Chip* consensus did not begin publishing its two-year forecasts until the middle of 1981, the first consensus forecast available for this comparison was published in early 1982. Average five-year projections, however, are published by *Blue Chip* only two or three times a year. All but one of its five-year projections used in this evaluation were published in March; the 1980-1984 projection was published in May.

Since 1985, the Congressional Budget Office has regularly included projections of economic profits and wage and salary disbursements in *The Economic and Budget Outlook*. Because book profits more closely reflect the corporate profits tax base than do economic profits, forecasts of book profits were extracted from CBO's unpublished forecast files. Unpublished CBO forecasts are used for both profits and wages for the 1980-1984 period.

Measuring Forecast Performance

Following earlier studies of economic forecasts, the evaluation of CBO's forecasts focused on two aspects of their performance: statistical bias and accuracy.

Bias

The statistical bias of a forecast is the extent to which the forecast can be expected to differ from what actually occurs. CBO's evaluation uses the *mean error* to measure statistical bias. That statistic—the arithmetic average of all the forecast errors—is the simplest and most widely used measure of forecast bias. Because the mean error is a simple average, however, underestimates and overestimates offset each other in calculating it. As a result, the mean error imperfectly measures the quality of a forecast—a small mean error would result if all the errors were small or if all the errors were large but the overestimates and underestimates happened to balance out.

Accuracy

The accuracy of a forecast is the degree to which forecast values are narrowly dispersed around actual outcomes. Measures of accuracy more clearly reflect the usual meaning of forecast performance than does the mean error. CBO's evaluation uses two measures of accuracy. The *mean absolute error*—the average of the forecast errors without regard to arithmetic sign—indicates the average distance between forecasts and actual values without regard to whether individual

4. Another exceptional case occurred in early 1993, when the Clinton Administration adopted CBO's economic assumptions as the basis for its budget. As a result, the errors for the early 1993 forecast are virtually the same for CBO and the Administration.

forecasts are overestimates or underestimates. The *root mean square error*—calculated by first squaring all the errors, then taking the square root of the arithmetic average of the squared errors—also shows the size of the error without regard to sign, but it gives greater weight to larger errors.

Measurement Issues

In addition to those three statistical indicators, there are many other measures of forecast performance. To test for statistical bias in CBO's forecasts, studies by analysts outside CBO have used measures that are slightly more elaborate than the mean error. Those studies have generally concluded, as does this evaluation, that CBO's short-term economic forecasts do not contain a statistically significant bias.⁵

In addition, a number of methods have been developed to evaluate a forecast's efficiency. Efficiency indicates the extent to which a particular forecast could have been improved by using additional information that was at the forecaster's disposal when the forecast was made.⁶ The *Blue Chip* consensus forecasts represent a wide variety of economic forecasters and thus reflect a broader blend of sources and methods than can be expected from any single forecaster. The use of the *Blue Chip* predictions in this evaluation can therefore be interpreted as a proxy for an efficient forecast. The fact that CBO's forecasts are about as

accurate as *Blue Chip*'s is a rough indication of their efficiency.

Such elaborate measures and methods, however, are not necessarily reliable indicators when the sample of observations is small, such as the 21 observations that make up the sample of CBO's two-year forecasts. Small samples present three main types of problems for evaluating forecasts, including forecasts based on the simple measures presented here. First, small samples reduce the reliability of statistical tests that are based on the assumption that the underlying population of forecast errors follows a normal distribution. The more elaborate tests of forecast performance all make such an assumption about the hypothetical ideal forecast with which the actual forecasts are compared. Second, in small samples, individual forecast errors have a relatively large weight in the calculation of summary measures. The mean error, for example, can fluctuate in arithmetic sign when a single observation is added to a small sample. Third, the small sample means that CBO's track record cannot be used in a statistically reliable way to indicate either the direction or the size of future forecasting errors.

Apart from the general caution that should attend statistical conclusions based on small samples, there are several other reasons to view this evaluation of CBO's forecasts with particular caution. First, the procedures and purposes of CBO's and the Administration's forecasts have changed over the past 20 years and may change again in the future. For example, in the late 1970s, CBO characterized its long-term projections as a goal for the economy, whereas it now considers its projections to be what will prevail on average if the economy continues to reflect historical trends. Second, an institution's forecasting track record may not foretell its future abilities because of changes in personnel or methods. Finally, forecast errors increase when the economy is more volatile. All three forecasters made exceptionally large errors when forecasting for periods that included turning points in the business cycle.

CBO's Forecasting Record

This analysis evaluated the Congressional Budget Office's forecasts over two-year and five-year periods.

5. Another approach to testing a forecast for bias is based on linear regression analysis of actual and forecast values. For details of that method, see J. Mincer and V. Zarnowitz, "The Evaluation of Economic Forecasts," in J. Mincer, ed., *Economic Forecasts and Expectations* (New York: National Bureau of Economic Research, 1969). That approach is not used here because of the small sample size. However, previous studies that have used it to evaluate the short-term forecasts of CBO and the Administration have not been able to reject the hypothesis that those forecasts are unbiased. See, for example, M.T. Belongia, "Are Economic Forecasts by Government Agencies Biased? Accurate?" *Review*, Federal Reserve Bank of St. Louis, vol. 70, no. 6 (November/December 1988), pp. 15-23.

6. For studies that have examined the relative efficiency of CBO's forecasts, see Belongia, "Are Economic Forecasts by Government Agencies Biased?"; and S.M. Miller, "Forecasting Federal Budget Deficits: How Reliable Are U.S. Congressional Budget Office Projections?" *Applied Economics*, vol. 23 (December 1991), pp. 1789-1799. Although both of the studies identify series that might have been used to make CBO's forecasts more accurate, they rely on statistics that assume a larger sample than is available. Moreover, although statistical tests can identify sources of inefficiency in a forecast after the fact, they generally do not indicate how such information can be used to improve forecasts when they are made.

The period of most interest for forecasters of the budget is two years. Because the Administration's and CBO's winter budget publications focus on the budget projection for the fiscal year beginning in the following October, an economic forecast that is accurate not only for the months leading up to the budget year but also for the budget year itself will provide the basis for a more accurate forecast of the budget balance. A five-year period is used to examine the accuracy of longer-term projections of growth in real output.

Short-Term Forecasts

Historically, the Congressional Budget Office's two-year forecasts are slightly more accurate than the Administration's and suffer from slightly less statistical bias. In most cases, however, the differences are small. Furthermore, CBO's forecasts are about as accurate as *Blue Chip's* average forecasts.

An accurate prediction of two-year growth in real output is the most important factor in minimizing errors when forecasting the deficit for the budget year. Accurate predictions of nominal output, inflation, and nominal interest rates are less important for such forecasts now than they were in the late 1970s and early 1980s. The reason is that given current law and the level of the national debt, inflation increases both revenues and outlays by similar amounts. Revenues increase with inflation because taxes are levied on nominal incomes. Outlays increase because various entitlement programs are indexed to inflation and because nominal interest rates tend to increase with inflation, which in turn raises the cost of servicing the federal debt.⁷

Growth in Real Output. For the two-year forecasts made between 1976 and 1996, CBO had a slightly better record than the Administration in predicting growth in real output (see Table A-1). On average, both CBO's and the Administration's forecasts tended to be overestimates. CBO was closer to the actual value in 10 of the 21 forecasts made between 1976 and 1996, the Administration was closer in seven peri-

ods, and both had identical errors in four periods. CBO's predictions of real growth made between 1982 and 1996 were, on average, as accurate as those of the *Blue Chip* consensus.

Forecast errors tend to be larger when the economy is more unstable. That tendency can be clearly seen in the forecasts of real GNP growth by comparing the large errors for 1979 through 1983—when the economy went through its most turbulent recessionary period of the postwar era—with the smaller errors recorded for later years. Similarly, the recent business cycle accounts for the large errors in the predictions made in the 1989-1991 period; during that time, the Congressional Budget Office's errors were only slightly larger than those of the *Blue Chip* consensus.

All three forecasters—CBO, the Administration, and *Blue Chip*—predicted two-year real GDP growth with striking accuracy in their early 1992, 1993, and 1994 forecasts. However, all three substantially underpredicted growth over the 1996-1997 period.

CPI Inflation. The records for forecasting the average annual growth in the consumer price index over a two-year period were very similar (see Table A-2). Both CBO and the Administration underestimated future inflation in their forecasts for 1977 through 1980, and both tended to overestimate it in their forecasts for 1981 through 1986. The average measures of bias and accuracy were virtually the same for both. CBO was closer to the actual value in seven of the 21 periods, the Administration was closer in nine periods, and the two forecasts had identical errors in five periods. For the 1982-1996 period, CBO's forecasts of inflation were as accurate as those of both the Administration and *Blue Chip*. Moreover, the track records of both CBO and the Administration in predicting inflation seem to have improved in the 1990s.

Nominal Interest Rates. For the 1976-1996 forecasts, CBO's record was about as accurate as the Administration's for nominal short-term interest rates over a two-year period (see Table A-3). On average, the Administration tended to underestimate nominal short-term interest rates; CBO's mean error was zero over that period. CBO was closer to the true value in 10 of the 21 periods, the Administration was closer in 10 periods, and the two forecasters had identical errors

7. Rules of thumb for estimating the effect on the budget balance of changes in various macroeconomic variables are given in Congressional Budget Office, *The Economic and Budget Outlook: Fiscal Years 1999-2008* (January 1998), pp. 97-100.

in one period. For the 1982-1996 period, however, the root mean square error of CBO's forecasts was slightly above those of the Administration and *Blue Chip*, which means that CBO made a few relatively large errors (such as those in 1982 and 1983).

For the 1984-1996 forecasts of long-term interest rates, CBO did somewhat better than the Administration (see Table A-4). The Administration tended to underestimate rates, and its mean error was larger than CBO's. In addition, the Administration's forecasts had a larger mean absolute error and root mean square error. CBO was closer to the true value in nine of the 13 periods, the Administration was closer in three periods, and the two forecasters had identical errors in one period.

The Congressional Budget Office's forecasts of long-term interest rates were about as accurate as those of the *Blue Chip* consensus. Both CBO and *Blue Chip* tended to overestimate long-term rates. CBO had a mean error of 0.2 percentage points compared with 0.3 percentage points for *Blue Chip*.

Real Short-Term Interest Rates. For the forecasts made in 1976 through 1996, CBO had a slight edge over the Administration in estimating real short-term interest rates (see Table A-5). Again, the Administration was more likely than CBO to underestimate interest rates, and its mean error was greater. CBO and the Administration recorded similar mean absolute and root mean square errors. CBO's forecasts were closer to the actual value in 12 of the 21 periods, the Administration's were closer in eight, and the two registered identical errors in one period. For forecasts made between 1982 and 1996, CBO's errors were generally similar in both direction and magnitude to those of the *Blue Chip* consensus.

Taxable Income. One of the greatest sources of error in forecasts of the deficit derives from projections of taxable income. On average, both CBO and the Administration have been too optimistic in their projections of the major components of taxable income (see Table A-6).

In general, the most significant overstatement of taxable income as a share of output took place in the early 1980s, when both agencies substantially overes-

timated wages and profits. In part, that overstatement stems from legislation (the Accelerated Cost Recovery System of the Economic Recovery Tax Act of 1981) that allowed corporations to shunt income away from taxable categories (book profits) to nontaxable or tax-favored categories (capital consumption). As a result of that legislation, which could not have been predicted when the early forecasts were made, the share of profits—and, hence, taxable income—was well below what it would have been in the absence of legislation.

In recent years, however, both CBO and the Administration have significantly underestimated the change in the wage and profit share. The rapid growth in corporate profits and dividends in both 1995 and 1996 reported in the July 1997 revisions of the national income and product accounts surprised most analysts.

Longer-Term Projections

In projecting real GNP growth for the more distant future, measured here as five years ahead, the Administration's errors were larger than CBO's (see Table A-7). Although that comparative advantage for CBO does not directly affect the estimates of the deficit for the budget year, accuracy in the longer term is obviously important for budgetary planning over several years. Neither the Administration nor CBO, however, considers its projections to be its best guess about the year-to-year course of the economy. The Administration's projections each year are based on the adoption of the President's budget as submitted, and for most years CBO has considered its projections an indication of the average future performance of the economy if major historical trends continue. Neither institution attempts to anticipate cyclical fluctuations in the projection period.

CBO's projections of longer-term growth in real output were closer to the actual value than the Administration's in 13 of the 18 forecasts. The Administration's projections showed an upward bias of 1.1 percentage points compared with an upward bias of 0.7 percentage points for CBO. Those biases occurred largely because the projections made in early 1976 through 1979, which CBO and the Administration pre-

sented as target rates of growth, did not incorporate the recessions of 1980 and 1982. Through the subsequent years of expansion until the most recent recession, the upward bias was much smaller for the Administration's projections and even smaller for CBO's. Both CBO and the Administration have underpredicted long-term growth based on projections made in early 1992 and early 1993. The only previous instance of underprediction in the long-term outlook occurred in the projections made in early 1983, when the economy was at a stage of the business cycle similar to that of the 1992 and 1993 projections.

The size of the root mean square errors for the entire period for CBO and, to a lesser extent, for the Administration also resulted largely from errors in projections made during the first four years. CBO was more accurate in its winter projections made in the 1980-1982 period but had a lesser edge in later years. Again, CBO's projections were about as accurate as those of the *Blue Chip* consensus over the comparable period.

Table A-1.
Comparison of CBO, Administration, and *Blue Chip* Forecasts of Two-Year Average Growth Rates for Real Output (By calendar year, in percent)

	Actual			Chain-Type Annual-Weighted Index	CBO		Administration		Blue Chip	
	1972 Dollars	1982 Dollars	1987 Dollars		Forecast	Error	Forecast	Error	Forecast	Error
GNP										
1976-1977	6.7	4.8	4.8	5.1	6.2	1.1	5.9	0.8	a	a
1977-1978	5.2	5.0	4.7	5.0	5.5	0.5	5.1	0.1	a	a
1978-1979	3.9	3.9	3.8	4.2	4.7	0.5	4.7	0.5	a	a
1979-1980	1.3	1.1	1.1	1.4	2.7	1.4	2.9	1.5	a	a
1980-1981	1.1	0.9	0.5	0.9	0.5	-0.3	0.5	-0.3	a	a
1981-1982	0.2	-0.3	-0.4	-0.1	2.1	2.2	2.6	2.7	a	a
1982-1983	0.7	0.5	0.7	0.8	2.1	1.3	2.7	1.9	2.0	1.2
1983-1984	5.2	5.2	4.9	5.4	3.4	-2.0	2.6	-2.7	3.5	-1.9
1984-1985	b	5.1	4.4	5.1	4.7	-0.3	4.7	-0.4	4.3	-0.8
1985-1986	b	3.0	2.8	3.1	3.3	0.3	3.9	0.9	3.2	0.1
1986-1987	b	3.1	2.9	2.9	3.1	0.3	3.7	0.8	3.0	0.1
1987-1988	b	3.9	3.5	3.4	2.9	-0.5	3.3	-0.1	2.8	-0.5
1988-1989	b	3.5	3.3	3.6	2.4	-1.2	3.0	-0.6	2.1	-1.5
1989-1990	b	1.7	2.0	2.3	2.5	0.2	3.2	0.9	2.2	-0.1
1990-1991	b	c	0.3	0.2	2.0	1.9	2.8	2.6	1.9	1.8
1991-1992	b	c	0.7	0.8	1.6	0.8	1.4	0.6	1.2	0.4
GDP^d										
1992-1993	b	c	2.7	2.5	2.6	0.1	2.2	-0.3	2.3	-0.2
1993-1994	b	c	3.6	2.9	2.9	0	2.9	0	3.0	0.2
1994-1995	b	c	e	2.9	2.8	-0.1	2.9	0.1	2.8	0
1995-1996	b	c	e	2.9	2.4	-0.4	2.6	-0.2	2.6	-0.2
1996-1997	b	c	e	3.7	1.9	-1.7	2.2	-1.4	2.1	-1.6
Statistics for 1976-1996										
Mean error	*	*	*	*	*	0.2	*	0.4	*	*
Mean absolute error	*	*	*	*	*	0.8	*	0.9	*	*
Root mean square error	*	*	*	*	*	1.1	*	1.3	*	*
Statistics for 1982-1996										
Mean error	*	*	*	*	*	-0.1	*	0.1	*	-0.2
Mean absolute error	*	*	*	*	*	0.7	*	0.9	*	0.7
Root mean square error	*	*	*	*	*	1.0	*	1.2	*	1.0

SOURCES: Congressional Budget Office; Office of Management and Budget; Capitol Publications, Inc., *Blue Chip Economic Indicators*; Department of Commerce, Bureau of Economic Analysis.

NOTES: Actual values are the two-year growth rates for real gross national product (GNP) and gross domestic product (GDP) last reported by the Bureau of Economic Analysis, not the first reported values. Forecast values are for the average annual growth of real GNP or GDP over the two-year period. The forecasts were issued in the first half of the initial year of the period or in December of the preceding year. Errors (which are in percentage points) are forecast values minus actual values; thus, a positive error is an overestimate. The chain-type annual-weighted index of actual GNP or GDP was used in calculating the errors.

* = not applicable.

- Two-year forecasts for the *Blue Chip* consensus were not available until 1982.
- Data for 1972-dollar GNP and GDP are available only through the third quarter of 1985.
- Data for 1982-dollar GNP and GDP are available only through the third quarter of 1991.
- With the 1992 benchmark revision, GDP replaced GNP as the central measure of national output.
- Data for 1987-dollar GNP and GDP are available only through the second and third quarters, respectively, of 1995.

Table A-2.
Comparison of CBO, Administration, and Blue Chip Forecasts of Two-Year Average Inflation Rates in the Consumer Price Index (By calendar year, in percent)

	Actual		CBO		Administration		Blue Chip	
	CPI-U	CPI-W	Forecast	Error	Forecast	Error	Forecast	Error
1976-1977	6.1	6.1	7.1	1.0	6.1	0	a	a
1977-1978	7.0	7.0	4.9	-2.1	5.2	-1.8	a	a
1978-1979	9.4	9.5	5.8	-3.7	6.0	-3.5	a	a
1979-1980	12.4	12.5	8.1	-4.3	7.4	-5.0	a	a
1980-1981	11.9	11.9	10.1	-1.8	10.5	-1.4	a	a
1981-1982	8.2	8.1	10.4	2.1	9.7	1.6	a	a
1982-1983	4.6	4.5	7.2	2.6	6.6	2.1	7.2	2.6
1983-1984	3.8	3.3	4.7	1.0	4.7	1.5	4.9	1.1
1984-1985	3.9	3.5	4.9	1.0	4.5	1.0	5.2	1.3
1985-1986	2.7	2.5	4.1	1.4	4.2	1.7	4.3	1.6
1986-1987	2.8	2.6	3.8	1.2	3.8	1.2	3.8	1.0
1987-1988	3.9	3.8	3.9	0.1	3.3	-0.5	3.6	-0.2
1988-1989	4.4	4.4	4.7	0.3	4.2	-0.2	4.3	-0.1
1989-1990	5.1	5.0	4.9	-0.1	3.7	-1.3	4.7	-0.4
1990-1991	4.8	4.6	4.1	-0.7	3.9	-0.7	4.1	-0.7
1991-1992	3.6	3.5	4.2	0.6	4.6	1.1	4.4	0.8
1992-1993	3.0	2.9	3.4	0.4	3.1	0.1	3.5	0.5
1993-1994	2.8	2.7	2.8	0.1	2.8	0.1	3.3	0.6
1994-1995	2.7	2.7	2.8	0.2	3.0	0.3	3.0	0.4
1995-1996	2.9	2.9	3.2	0.4	3.1	0.3	3.4	0.6
1996-1997	2.6	2.6	2.9	0.3	2.9	0.3	2.8	0.2
Statistics for 1976-1996								
Mean error	*	*	*	0	*	-0.1	*	*
Mean absolute error	*	*	*	1.2	*	1.2	*	*
Root mean square error	*	*	*	1.7	*	1.7	*	*
Statistics for 1982-1996								
Mean error	*	*	*	0.6	*	0.5	*	0.6
Mean absolute error	*	*	*	0.7	*	0.8	*	0.8
Root mean square error	*	*	*	0.9	*	1.0	*	1.0

SOURCES: Congressional Budget Office; Office of Management and Budget; Capitol Publications, Inc., *Blue Chip Economic Indicators*; Department of Labor, Bureau of Labor Statistics.

NOTES: Values are for the average annual growth of the consumer price index (CPI) over the two-year period. Before 1978, the Bureau of Labor Statistics published only one consumer price index series, now known as the CPI-W (the price index for urban wage earners and clerical workers). In January 1978, however, the bureau began to publish a second, broader consumer price index series, the CPI-U (the price index for all urban consumers). For most years since 1979, CBO forecast the CPI-U; from 1986 through 1989, however, CBO forecast the CPI-W. The Administration forecast the CPI-W until 1992, when it switched to the CPI-U. *Blue Chip* forecast the CPI-U for the entire period. The forecasts were issued in the first half of the initial year of the period or in December of the preceding year. Errors (which are in percentage points) are forecast values minus actual values; thus, a positive error is an overestimate.

* = not applicable.

a. Two-year forecasts for the *Blue Chip* consensus were not available until 1982.

Table A-3.
Comparison of CBO, Administration, and *Blue Chip* Forecasts of Two-Year Average Interest Rates on Three-Month Treasury Bills (By calendar year, in percent)

	Actual		CBO		Administration		<i>Blue Chip</i>	
	New Issue	Secondary Market	Forecast	Error	Forecast	Error	Forecast	Error
1976-1977	5.1	5.1	6.2	1.1	5.5	0.4	a	a
1977-1978	6.2	6.2	6.4	0.2	4.4	-1.8	a	a
1978-1979	8.6	8.6	6.0	-2.6	6.1	-2.5	a	a
1979-1980	10.8	10.7	8.3	-2.4	8.2	-2.6	a	a
1980-1981	12.8	12.7	9.5	-3.2	9.7	-3.1	a	a
1981-1982	12.4	12.3	13.2	0.9	10.0	-2.4	a	a
1982-1983	9.7	9.6	12.6	3.0	11.1	1.4	11.3	1.6
1983-1984	9.1	9.1	7.1	-2.0	7.9	-1.1	7.9	-1.2
1984-1985	8.5	8.5	8.7	0.3	8.1	-0.4	9.1	0.5
1985-1986	6.7	6.7	8.5	1.8	8.0	1.3	8.5	1.8
1986-1987	5.9	5.9	6.7	0.9	6.9	1.0	7.1	1.2
1987-1988	6.2	6.2	5.6	-0.6	5.5	-0.7	5.7	-0.5
1988-1989	7.4	7.4	6.4	-0.9	5.2	-2.1	6.1	-1.2
1989-1990	7.8	7.8	7.5	-0.3	5.9	-1.9	7.5	-0.3
1990-1991	6.5	6.4	7.0	0.6	6.0	-0.4	7.1	0.7
1991-1992	4.4	4.4	6.8	2.4	6.2	1.8	6.4	2.0
1992-1993	3.2	3.2	4.7	1.5	4.5	1.3	4.6	1.4
1993-1994	3.6	3.6	3.4	-0.2	3.4	-0.2	3.8	0.2
1994-1995	4.9	4.9	3.9	-1.0	3.6	-1.3	3.6	-1.3
1995-1996	5.3	5.2	5.9	0.7	5.7	0.4	6.1	0.9
1996-1997	5.0	5.0	4.8	-0.2	4.7	-0.3	5.0	0
Statistics for 1976-1996								
Mean error	*	*	*	0	*	-0.6	*	*
Mean absolute error	*	*	*	1.3	*	1.4	*	*
Root mean square error	*	*	*	1.6	*	1.6	*	*
Statistics for 1982-1996								
Mean error	*	*	*	0.4	*	-0.1	*	0.4
Mean absolute error	*	*	*	1.1	*	1.1	*	1.0
Root mean square error	*	*	*	1.4	*	1.2	*	1.2

SOURCES: Congressional Budget Office; Office of Management and Budget; Capitol Publications, Inc., *Blue Chip Economic Indicators*; Federal Reserve Board.

NOTES: Values are for the geometric averages of the three-month Treasury bill rates for the two-year period. The actual values are published by the Federal Reserve Board as the rate on new issues (reported on a bank-discount basis) and the secondary-market rate. CBO forecast the secondary-market rate; the Administration forecast the new-issue rate. *Blue Chip* alternated between the two rates, forecasting the new-issue rate from 1982 to 1985, the secondary-market rate from 1986 to 1991, and the new-issue rate again beginning in 1992. The forecasts were issued in the first half of the initial year of the period or in December of the preceding year. Errors (which are in percentage points) are forecast values minus actual values; thus, a positive error is an overestimate.

* = not applicable.

a. Two-year forecasts for the *Blue Chip* consensus were not available until 1982.

Table A-4.
Comparison of CBO, Administration, and *Blue Chip* Forecasts of Two-Year Average Long-Term Interest Rates (By calendar year, in percent)

	Actual		CBO		Administration		Blue Chip	
	10-Year Note	Corporate Aaa Bond	Forecast	Error	Forecast	Error	Forecast	Error
1984-1985	11.5	12.0	11.9	-0.1	9.7	-1.8	12.2	0.2
1985-1986	9.1	10.2	11.5	1.3	10.6	1.5	11.8	1.7
1986-1987	8.0	9.2	8.9	0.9	8.7	0.7	9.9	0.8
1987-1988	8.6	9.5	7.2	-1.4	6.6	-2.0	8.7	-0.8
1988-1989	8.7	9.5	9.4	0.7	7.7	-1.0	9.8	0.3
1989-1990	8.5	9.3	9.1	0.6	7.7	-0.8	9.5	0.3
1990-1991	8.2	9.0	7.7	-0.5	7.2	-1.0	8.7	-0.3
1991-1992	7.4	8.5	7.8	0.4	7.3	-0.1	8.7	0.3
1992-1993	6.4	7.7	7.1	0.7	6.9	0.5	8.4	0.7
1993-1994	6.5	7.6	6.6	0.2	6.6	0.2	8.2	0.6
1994-1995	6.8	7.8	5.9	-0.9	5.8	-1.0	7.1	-0.7
1995-1996	6.5	7.5	7.3	0.8	7.5	1.0	8.6	1.1
1996-1997	6.4	7.3	6.2	-0.1	5.4	-0.9	6.2	-0.1
Statistics for 1984-1996								
Mean error	*	*	*	0.2	*	-0.4	*	0.3
Mean absolute error	*	*	*	0.7	*	1.0	*	0.6
Root mean square error	*	*	*	0.8	*	1.1	*	0.7

SOURCES: Congressional Budget Office; Office of Management and Budget; Capitol Publications, Inc., *Blue Chip Economic Indicators*; Federal Reserve Board.

NOTES: Actual values are for the geometric averages of the 10-year Treasury note rates or Moody's corporate Aaa bond rates for the two-year period as reported by the Federal Reserve Board. CBO forecast the 10-year Treasury note rate in all years except 1984 and 1985. The Administration forecast the 10-year note rate, but *Blue Chip* forecast the corporate Aaa bond rate. Data are only available beginning in 1984 because not all of the forecasters published long-term rate projections before then. The forecasts were issued in the first half of the initial year of the period or in December of the preceding year. Errors (which are in percentage points) are forecast values minus actual values; thus, a positive error is an overestimate.

* = not applicable.

Table A-5.
Comparison of CBO, Administration, and *Blue Chip* Forecasts of Two-Year Average Real Interest Rates on Three-Month Treasury Bills (By calendar year, in percent)

	Actual				CBO		Administration		<i>Blue Chip</i>	
	New Issue		Secondary Market		Forecast	Error	Forecast	Error	Forecast	Error
	CPI-U	CPI-W	CPI-U	CPI-W						
1976-1977	-0.9	-0.9	-0.9	-0.9	-0.8	0.1	-0.6	0.3	a	a
1977-1978	-0.8	-0.7	-0.8	-0.7	1.5	2.2	-0.8	-0.1	a	a
1978-1979	-0.7	-0.8	-0.7	-0.8	0.2	1.0	0.1	0.9	a	a
1979-1980	-1.4	-1.5	-1.4	-1.5	0.2	1.7	0.7	2.2	a	a
1980-1981	0.8	0.9	0.7	0.8	-0.5	-1.2	-0.7	-1.6	a	a
1981-1982	3.8	4.0	3.7	3.9	2.6	-1.2	0.3	-3.7	a	a
1982-1983	4.8	4.9	4.7	4.9	5.0	0.3	4.2	-0.8	3.8	-1.0
1983-1984	5.1	5.7	5.1	5.6	2.2	-2.9	3.1	-2.6	2.9	-2.3
1984-1985	4.4	4.9	4.4	4.8	3.6	-0.8	3.4	-1.4	3.6	-0.8
1985-1986	3.9	4.1	3.9	4.1	4.2	0.3	3.6	-0.4	4.0	0.1
1986-1987	3.0	3.2	3.0	3.2	2.8	-0.4	3.0	-0.3	3.2	0.2
1987-1988	2.3	2.4	2.3	2.3	1.7	-0.6	2.1	-0.2	2.0	-0.3
1988-1989	2.8	2.9	2.8	2.9	1.7	-1.2	1.0	-1.9	1.8	-1.1
1989-1990	2.6	2.6	2.6	2.6	2.5	-0.2	2.1	-0.6	2.7	0.2
1990-1991	1.6	1.7	1.5	1.7	2.8	1.2	2.0	0.3	2.9	1.3
1991-1992	0.8	0.9	0.7	0.9	2.5	1.8	1.5	0.6	1.9	1.2
1992-1993	0.2	0.4	0.2	0.3	1.3	1.0	1.3	1.1	1.1	0.8
1993-1994	0.8	0.9	0.8	0.9	0.5	-0.3	0.6	-0.3	0.5	-0.4
1994-1995	2.1	2.2	2.1	2.1	1.0	-1.1	0.6	-1.6	0.5	-1.6
1995-1996	2.3	2.3	2.3	2.3	2.6	0.3	2.5	0.1	2.6	0.3
1996-1997	2.4	2.4	2.3	2.4	1.8	-0.5	1.7	-0.6	2.1	-0.3
Statistics for 1976-1996										
Mean error	*	*	*	*	*	0	*	-0.5	*	*
Mean absolute error	*	*	*	*	*	1.0	*	1.0	*	*
Root mean square error	*	*	*	*	*	1.2	*	1.4	*	*
Statistics for 1982-1996										
Mean error	*	*	*	*	*	-0.2	*	-0.6	*	-0.2
Mean absolute error	*	*	*	*	*	0.9	*	0.8	*	0.8
Root mean square error	*	*	*	*	*	1.1	*	1.1	*	1.0

SOURCES: Congressional Budget Office; Office of Management and Budget; Capitol Publications, Inc., *Blue Chip Economic Indicators*; Department of Labor, Bureau of Labor Statistics; Federal Reserve Board.

NOTES: Values are for the appropriate three-month Treasury bill rate discounted by the respective forecast for inflation as measured by the change in the consumer price index. The forecasts were issued in the first half of the initial year of the period or in December of the preceding year. Errors (which are in percentage points) are forecast values minus actual values; thus, a positive error is an overestimate.

CPI-U = consumer price index for all urban consumers; CPI-W = consumer price index for urban wage earners and clerical workers; * = not applicable.

a. Two-year forecasts for the *Blue Chip* consensus were not available until 1982.

Table A-6.
Comparison of CBO and Administration Projections of the Two-Year Change in Wage and Salary Distributions Plus Book Profits as a Share of Output (By calendar year, in percent)

	Actual	CBO		Administration	
		Forecast	Error	Forecast	Error
1980-1981	-3.1	-0.6	2.5	-1.3	1.8
1981-1982	-3.3	-2.6	0.7	-1.2	2.1
1982-1983	-1.9	-1.8	0.2	-1.7	0.3
1983-1984	-0.7	0	0.7	-1.0	-0.3
1984-1985	-0.5	-0.2	0.3	-0.2	0.4
1985-1986	-0.6	-0.6	0	-0.8	-0.2
1986-1987	1.6	1.0	-0.6	0.8	-0.8
1987-1988	2.7	0.9	-1.8	1.4	-1.3
1988-1989	-0.6	0.6	1.2	0.4	0.9
1989-1990	-1.2	0.4	1.6	0.7	1.9
1990-1991	-0.1	0.7	0.7	1.4	1.5
1991-1992	0	0.1	0.1	-0.1	0
1992-1993	0.1	1.0	0.9	1.4	1.3
1993-1994	0	0.5	0.5	0.5	0.5
1994-1995	1.7	0.2	-1.5	0.4	-1.3
1995-1996	1.9	-0.3	-2.2	-0.6	-2.6
1996-1997	1.1	-0.3	-1.5	0.8	-0.3
Statistics for 1980-1996					
Mean error	*	*	0.1	*	0.2
Mean absolute error	*	*	1.0	*	1.0
Root mean square error	*	*	1.2	*	1.3

SOURCES: Congressional Budget Office; Office of Management and Budget; Department of Commerce, Bureau of Economic Analysis.

NOTES: The forecasts were issued in the first half of the initial year of the period or in December of the preceding year. Errors (which are in percentage points) are forecast values minus actual values; thus, a positive error is an overestimate. For the forecasts made between 1980 and 1991, gross national product was used in calculating the shares; for the forecasts made in 1992 and later, gross domestic product was used.

* = not applicable.

Table A-7.
Comparison of CBO, Administration, and *Blue Chip* Projections of Five-Year Average Growth Rates for Real Output (By calendar year, in percent)

	Actual				CBO		Administration		Blue Chip	
	1972 Dollars	1982 Dollars	1987 Dollars	Chain-Type Annual- Weighted Index	Projection	Error	Projection	Error	Projection	Error
GNP										
1976-1980	4.2	3.4	3.3	3.7	5.7	2.0	6.2	2.5	a	a
1977-1981	3.1	2.8	2.6	3.0	5.3	2.3	5.1	2.1	a	a
1978-1982	1.6	1.4	1.2	1.6	4.8	3.2	4.8	3.2	a	a
1979-1983	1.3	1.0	1.1	1.3	3.8	2.5	3.8	2.5	3.1	1.8
1980-1984	2.1	1.9	1.7	2.0	2.4	0.4	3.0	1.0	2.5	0.5
1981-1985	b	2.6	2.4	2.7	2.8	0	3.8	1.1	3.0	0.3
1982-1986	b	2.7	2.6	2.9	3.0	0.1	3.9	1.0	2.7	-0.1
1983-1987	b	4.0	3.7	3.9	3.6	-0.3	3.5	-0.5	3.5	-0.5
1984-1988	b	4.1	3.7	3.9	4.0	0	4.3	0.3	3.5	-0.5
1985-1989	b	3.3	3.1	3.2	3.4	0.1	4.0	0.7	3.4	0.1
1986-1990	b	2.8	2.7	2.9	3.3	0.5	3.8	0.9	3.1	0.3
1987-1991	b	c	2.0	2.1	2.9	0.8	3.5	1.4	2.7	0.6
1988-1992	b	c	1.9	2.0	2.6	0.5	3.2	1.2	2.5	0.5
1989-1993	b	c	1.7	1.7	2.3	0.6	3.2	1.5	2.6	0.8
1990-1994	b	c	1.9	1.7	2.3	0.6	3.0	1.2	2.4	0.7
1991-1995	b	c	d	1.9	2.3	0.4	2.5	0.6	2.0	0.0
GDP^a										
1992-1996	b	c	d	2.8	2.6	-0.2	2.7	-0.2	2.5	-0.4
1993-1997	b	c	d	3.1	2.8	-0.3	2.8	-0.3	2.8	-0.3
Statistics for 1976-1993										
Mean error	*	*	*	*	*	0.7	*	1.1	*	*
Mean absolute error	*	*	*	*	*	0.8	*	1.2	*	*
Root mean square error	*	*	*	*	*	1.3	*	1.5	*	*
Statistics for 1979-1993										
Mean error	*	*	*	*	*	0.4	*	0.8	*	0.3
Mean absolute error	*	*	*	*	*	0.5	*	1.0	*	0.5
Root mean square error	*	*	*	*	*	0.8	*	1.1	*	0.6

SOURCES: Congressional Budget Office; Office of Management and Budget; Capitol Publications, Inc., *Blue Chip Economic Indicators*; Department of Commerce, Bureau of Economic Analysis.

NOTES: Actual values are for the five-year growth rates for real gross national product (GNP) and gross domestic product (GDP) last reported by the Bureau of Economic Analysis, not the first reported values. Projected values are for the average growth of real GNP or GDP over the five-year period. The majority of the projections were issued in the first quarter of the initial year of the period or in December of the preceding year. Errors (which are in percentage points) are projected values minus actual values; thus, a positive error is an overestimate. The chain-type annual-weighted index of actual GNP or GDP was used in calculating the errors.

* = not applicable.

- Five-year forecasts for the *Blue Chip* consensus were not available until 1979.
- Data for 1972-dollar GNP are available only through the third quarter of 1985.
- Data for 1982-dollar GNP are available only through the third quarter of 1991.
- Data for 1987-dollar GNP and GDP are available only through the second and third quarters, respectively, of 1995.
- With the 1992 benchmark revision, GDP replaced GNP as the central measure of national output.

Sequestration Update Report for Fiscal Year 1999

The Congressional Budget Office (CBO) believes it is too early to predict the likelihood of a discretionary sequestration in fiscal year 1999. The legislation affecting mandatory spending and revenues that has been adopted through August 7, 1998, would not trigger a pay-as-you-go (PAYGO) sequestration.¹

Discretionary Sequestration Report

The Balanced Budget and Emergency Deficit Control Act (the Deficit Control Act) sets limits on discretionary spending and provides for across-the-board cuts—known as sequestration—if annual appropriations exceed those limits. The caps are in effect through fiscal year 2002.

Before enactment of the Transportation Equity Act for the 21st Century (TEA-21) in June, the Deficit Control Act split discretionary spending into three categories for fiscal years 1998 and 1999: defense, non-defense, and spending to reduce violent crime. Separate limits applied to budget authority and outlays in each category. For fiscal year 2000, the act combined

defense and nondefense spending into a single discretionary category and retained a separate category for violent crime reduction. For fiscal years 2001 and 2002, the act folded all three types of spending into one discretionary category, so the limits would apply to total discretionary spending. (The joint explanatory statement that accompanied the conference report on the Balanced Budget Act of 1997 specified which category each appropriation account fell into.)

TEA-21 altered that structure by establishing two new caps that apply to outlays for specified highway and mass transit programs (which had been included in the nondefense caps) beginning in 1999. TEA-21 also reduced the caps on nondefense spending in 1999 and the caps on overall discretionary spending in 2000, 2001, and 2002. Because the new caps on highway and mass transit spending exceed the reductions in the other caps, the amount of discretionary outlays allowed under the Deficit Control Act was increased by a total of \$15.4 billion from 1999 through 2002.

By law, the discretionary spending limits are adjusted each year to account for such things as the enactment of emergency appropriations and changes in budgetary concepts and definitions. TEA-21 added special adjustments for the transportation caps. It requires that the caps on highway spending be adjusted each year in the sequestration preview report to reflect differences between current and future estimates of the revenues that will be attributed to the Highway Trust

1. This sequestration update report is a Congressional Budget Office report to the Congress and the Office of Management and Budget pursuant to section 254 of the Balanced Budget and Emergency Deficit Control Act.

Fund. The legislation also requires that both types of transportation caps be adjusted each year to reflect any changes in technical estimates of the outlays that will result from the TEA-21 funding levels.

Under section 1024(b) of the Line Item Veto Act, the discretionary spending caps would have been adjusted by the amount of any Presidential cancellations of discretionary budget authority and outlays that were not overturned by a Congressional disapproval bill. No line-item veto cancellations were ever reflected in the caps, however, because the Supreme Court ruled the Line Item Veto Act unconstitutional in June.

Differences Between the Limits in CBO's and OMB's Preview Reports

The Office of Management and Budget (OMB) estimates whether a sequestration is required to eliminate a breach of the discretionary spending limits. (CBO's estimates are merely advisory.) As a result, CBO uses the estimated limits in OMB's most recent sequestration report—in this case, the preview report for fiscal year 1999, published in February—as the starting point for the adjustments it is required to make in this sequestration update report for 1999.

The caps in the two agencies' preview reports differed because of differing estimates of required adjustments for changes in budgetary concepts and definitions. CBO's estimate of the adjustment in the defense discretionary category for fiscal year 1999 was lower than OMB's by \$68 million in budget authority and \$67 million in outlays (see Table B-1). CBO's estimate of the adjustment in the nondefense discretionary category for 1999 was higher than OMB's by \$254 million in budget authority and \$297 million in outlays. For 2000 through 2002, CBO's estimates for the overall discretionary category were also slightly higher than OMB's.

Most of the differences resulted from different estimates of changes in mandatory spending contained in fiscal year 1998 appropriation acts—particularly the estimates of a provision in the 1998 Treasury and General Government Appropriations Act to permit federal employees, for a limited period of time, to switch from the Civil Service Retirement System to the Federal Employees Retirement System. Another

difference occurred because OMB reestimated the cost of arrears that the United States owes to various multilateral development banks, whereas CBO did not. The two agencies also had different estimates of changes in discretionary spending contained in authorizing legislation (primarily the Balanced Budget Act of 1997).

In addition, OMB adjusted the defense and nondefense caps for 1999 to reflect the reclassification of spending for the Formerly Utilized Sites Remedial Action Program from the natural resources and environment function in the budget to the national defense function. Since that reclassification did not affect total discretionary spending, the caps on overall discretionary spending for 2000 through 2002 were not adjusted.

Emergency Funding Made Available Since OMB's Preview Report

As required by law, CBO has also adjusted the discretionary spending limits to reflect emergency appropriations enacted since OMB's preview report. Between March and August, the Congress enacted emergency appropriations totaling \$5,448 million in 1998 budget authority. More than half of that amount (\$2,832 million) was in the defense discretionary category, and the remainder (\$2,616 million) was in the nondefense discretionary category. The availability of some of those appropriations is contingent on their designation by the President as emergency requirements. CBO includes such appropriations in its cap adjustments because no further action by the Congress is needed to make them available.

Outlays from those emergency appropriations total \$1,012 million in fiscal year 1998, \$2,007 million in 1999, \$1,136 million in 2000, \$853 million in 2001, and \$412 million in 2002. The outlay caps for both the defense and nondefense categories for 1998 and 1999 are adjusted to reflect the emergency spending for programs in those categories. Estimated emergency outlays for those programs also result in an increase in the caps on overall discretionary spending for 2000 through 2002. In addition, an emergency appropriation for the federal-aid highway account triggers an increase in the caps on highway spending for 1999 through 2002.

CBO has also adjusted the limits on discretionary spending for contingent emergency appropriations that the President has released since the publication of OMB's preview report. That adjustment is necessary because CBO starts with the limits in OMB's previous report, and those limits (unlike CBO's) include adjustments only for such appropriations that have already been released by the President. Since February, the President has released \$100 million in 1998 contingent emergency appropriations for the Low Income Home Energy Assistance Program, which CBO estimates will increase nondefense discretionary outlays by \$50 million in both 1998 and 1999.

Caps on Highway and Mass Transit Spending

As noted above, TEA-21 established two new caps beginning in fiscal year 1999 that apply to outlays for specified highway and mass transit programs; it also reduced the existing caps on nondefense spending in 1999 and the caps on other discretionary spending in 2000, 2001, and 2002. The highway category does not have a cap on budget authority because all of the spending in that category is controlled by the obligation limitations set in appropriation bills, which do not count as budget authority. Although spending for mass transit is controlled by a combination of appropriations and obligation limitations (which likewise are not counted as budget authority), that category has no limit on budget authority either. In his budget for fiscal year 1999, the President proposed redefining transportation obligation limitations as budget authority for both highway and mass transit spending, but that proposal has not been carried out.

Pay-As-You-Go Sequestration Report

The Deficit Control Act also contains a mechanism to ensure that any legislative changes in direct spending or receipts enacted since the Budget Enforcement Act of 1997 and before 2003 do not increase the defi-

cit. That mechanism is the PAYGO sequestration. If legislative changes enacted through the end of a session of Congress increase the deficit (or reduce a projected surplus), a PAYGO sequestration is required at the end of the session. Under the sequestration, mandatory programs (other than those specifically exempt) are cut by enough to eliminate the increase. The PAYGO discipline applies to legislation enacted through 2002, but the sequestration procedure applies through 2006 to eliminate any increase in the deficit or decrease in a projected surplus caused by that legislation.

Both CBO and OMB are required to estimate the net change in the deficit that results from direct spending or receipt legislation. As with the discretionary spending limits, however, OMB's estimates determine whether a sequestration is necessary. CBO has therefore adopted the estimated effects of legislation from OMB's preview report as the starting point for this report. In February, OMB estimated that the effect of legislation enacted between the time of the Budget Enforcement Act and December 16, 1997, resulted in an \$11 million increase in the deficit (actually, a reduction in the surplus) in 1999. That estimate excludes changes resulting from legislation enacted before the Budget Enforcement Act, because the act removed all available balances from the PAYGO scorecard. In addition, legislation enacted between the time of OMB's November final sequestration report and December 16, 1997, had a favorable effect of \$153 million in 1998. (The balance for 1998 in OMB's final report is not available to offset increases in mandatory spending or decreases in revenues in fiscal year 1999.)

Legislation enacted since OMB's February preview report has reduced the deficit by \$598 million in 1998 and \$1,114 million in 1999, according to CBO's estimates. When added to the amounts in OMB's report, the result is a favorable balance of \$751 million for 1998 and \$1,103 million for 1999 (see Table B-2). Thus, the Congress could enact legislation increasing mandatory spending or decreasing revenues by a total of \$1,854 million in 1998 and 1999 without triggering a PAYGO sequestration. Those figures include the budget year effect of all legislation on which the Congress completed action before its August recess.

Table B-1.
CBO Estimates of Discretionary Spending Limits for Fiscal Years 1998-2002 (In millions of dollars)

	1998		1999		2000		2001		2002	
	Budget Authority	Outlays	Budget Authority	Outlays	Budget Authority	Outlays	Budget Authority	Outlays	Budget Authority	Outlays
Total Discretionary Spending Limits in CBO's January Preview Report	528,006	557,643	533,006	561,115	537,156	564,794	541,989	564,198	551,023	560,478
Defense Discretionary Category ^a										
Spending limits in CBO's January preview report	269,000	267,124	271,502	266,568	*	*	*	*	*	*
Adjustments										
Technical differences from OMB's February preview report	0	0	68	67	*	*	*	*	*	*
Emergency 1998 appropriations enacted since OMB's preview report	2,832	612	0	1,644	*	*	*	*	*	*
Spending limits as of August 15, 1998	271,832	267,736	271,570	268,279	*	*	*	*	*	*
Nondefense Discretionary Category ^a										
Spending limits in CBO's January preview report	253,506	285,686	255,704	289,594	*	*	*	*	*	*
Adjustments										
Technical differences from OMB's February preview report	0	0	-254	-297	*	*	*	*	*	*
Emergency 1998 appropriations enacted since OMB's preview report	2,616	400	0	254	*	*	*	*	*	*
Contingent emergency appropriations designated since OMB's preview report	100	50	0	50	*	*	*	*	*	*
Reductions specified in TEA-21	*	*	-859	-25,144	*	*	*	*	*	*
Spending limits as of August 15, 1998	256,222	286,136	254,591	264,457	*	*	*	*	*	*
Violent Crime Reduction Category ^b										
Spending limits in CBO's January preview report	5,500	4,833	5,800	4,953	4,500	5,554	*	*	*	*
Adjustments	0	0	0	0	0	0	*	*	*	*
Spending limits as of August 15, 1998	5,500	4,833	5,800	4,953	4,500	5,554	*	*	*	*

(Continued)

Table B-1.
Continued

	1998		1999		2000		2001		2002	
	Budget Authority	Outlays	Budget Authority	Outlays	Budget Authority	Outlays	Budget Authority	Outlays	Budget Authority	Outlays
Overall Discretionary Category ^a										
Spending limits in CBO's January preview report	*	*	*	*	532,656	559,240	541,989	564,198	551,023	560,478
Adjustments										
Technical differences from OMB's February preview report	*	*	*	*	-171	-111	-179	-125	-183	-132
Emergency 1998 appropriations enacted since OMB's preview report	*	*	*	*	0	1,097	0	827	0	397
Reductions specified in TEA-21	*	*	*	*	-859	-26,009	-859	-26,329	-859	-26,675
Spending limits as of August 15, 1998	*	*	*	*	531,626	534,217	540,951	538,571	549,981	534,068
Highway Category										
Spending limits in TEA-21	*	*	d	21,885	d	24,436	d	26,204	d	26,977
Adjustments (Emergency 1998 appropriations enacted since OMB's preview report)	*	*	d	109	d	39	d	26	d	15
Spending limits as of August 15, 1998	*	*	d	21,994	d	24,475	d	26,230	d	26,992
Mass Transit Category										
Spending limits in TEA-21	*	*	d	4,401	d	4,761	d	5,190	d	5,709
Adjustments	*	*	d	0	d	0	d	0	d	0
Spending limits as of August 15, 1998	*	*	d	4,401	d	4,761	d	5,190	d	5,709
Total Discretionary Spending Limits as of August 15, 1998	533,554	558,705	531,961	564,084	536,126	569,007	540,951	569,991	549,981	566,769

SOURCE: Congressional Budget Office.

NOTE: * = not applicable; OMB = Office of Management and Budget; TEA-21 = Transportation Equity Act for the 21st Century.

- a. This category is folded into the overall discretionary category after fiscal year 1999.
- b. This category is folded into the overall discretionary category after fiscal year 2000.
- c. This category comprises defense and nondefense spending in fiscal year 2000, plus violent crime reduction spending in 2001 and 2002.
- d. There are no limits on budget authority for the highway and mass transit categories. All of the spending in the highway category, and most of the spending in the mass transit category, is controlled by obligation limitations, which are not counted as budget authority.

Table B-2.
Budgetary Effects of Direct Spending or Receipt Legislation
Enacted Since the Budget Enforcement Act of 1997 (By fiscal year, in millions of dollars)

	1998	1999	2000	2001	2002	2003
Total for OMB's February 1998 Preview Report ^a	-153	11	16	14	10	9
Legislation Enacted Since OMB's Preview Report						
An act to authorize the Secretary of Agriculture to convey certain lands and improvements in the State of Virginia (P.L. 105-171)	0	-1	-1	0	0	0
Transportation Equity Act for the 21st Century (P.L. 105-178) ^{b,c}	-440	-392	249	320	194	133
Care for Police Survivors Act of 1998 (P.L. 105-180)	1	1	1	1	1	1
Agricultural Research, Extension, and Education Reform Act of 1998 (P.L. 105-185)	0	5	24	-50	-53	-33
Agricultural Export Relief Act of 1998 (P.L. 105-194)	7	24	11	0	0	0
Child Support Performance and Incentive Act of 1998 (P.L. 105-200)	0	-100	-55	-65	10	210
Internal Revenue Service Restructuring and Reform Act of 1998 (P.L. 105-206) ^{b,d}	-168	-659	-519	241	806	1,157
Homeowners Protection Act of 1997 (P.L. 105-216)	2	2	0	0	0	0
Credit Union Membership Access Act (P.L. 105-219) ^e	0	6	16	27	40	54
Increase or Reduction (-) in the Net Deficit	-751	-1,103	-258	488	1,008	1,531

SOURCE: Congressional Budget Office.

NOTES: The following bills affected direct spending or receipts but did not increase or decrease the deficit by as much as \$500,000 in any year through 2003: Environmental Policy and Conflict Resolution Act of 1997 (P.L. 105-156); an act to consolidate certain mineral interests in national grasslands in Billings County, North Dakota (P.L. 105-167); Wireless Telephone Protection Act (P.L. 105-172); an act to amend the Immigration and Nationality Act to modify and extend the visa waiver pilot program (P.L. 105-173); Telemarketing Fraud Prevention Act of 1997 (P.L. 105-184); U.S. Holocaust Assets Commission Act of 1998 (P.L. 105-186); Deadbeat Parents Punishment Act of 1998 (P.L. 105-187); an act to validate certain conveyances in the City of Tulare, Tulare County, California (P.L. 105-195); National Drought Policy Act of 1998 (P.L. 105-199); an act to make a minor adjustment in the exterior boundary of the Devils Backbone Wilderness in the Mark Twain National Forest, Missouri (P.L. 105-210); an act to award a Congressional gold medal to Nelson Rolihlahla Mandela (P.L. 105-215); Workforce Investment Act of 1998 (P.L. 105-220); an act to establish the United States Capitol Police Memorial Fund (P.L. 105-223); an act to provide for the conveyance of small parcels of land in the Carson National Forest and the Santa Fe National Forest, New Mexico, to the village of El Rito and the town of Jemez Springs, New Mexico (H.R. 434); Foreign Relations Authorization Act (H.R. 1757); Nazi War Crimes Disclosure Act (S. 1379); and Emergency Farm Financial Relief Act (S. 2344).

OMB = Office of Management and Budget; P.L. = Public Law.

- a. Section 254 of the Balanced Budget and Emergency Deficit Control Act of 1985, as amended by the Budget Enforcement Act of 1990, calls for a list of all the bills that are included in the pay-as-you-go calculation. Because the data in this table assume OMB's estimate of the total change in the deficit resulting from bills enacted through the date of its report, readers are referred to the list of those bills included in Tables 6 and 7 of the *OMB Final Sequestration Report to the President and Congress* issued on November 24, 1997, and in previous sequestration reports issued by OMB.
- b. Change in outlays and receipts.
- c. Pursuant to section 8102 of P.L. 105-178, the figures shown exclude direct spending and receipts from title VIII of this act.
- d. Pursuant to section 3309 of P.L. 105-206, the figures shown exclude the effects of receipts that were designated as an emergency requirement under section 252(e) of the Balanced Budget and Emergency Deficit Control Act.
- e. The direct spending effects of this bill are excluded because they are related to guarantee commitments for deposit insurance, which are exempt from the pay-as-you-go procedures under the Balanced Budget and Emergency Deficit Control Act.

Major Contributors to the Revenue and Spending Projections

The following Congressional Budget Office analysts prepared the revenue and spending projections in this report:

Revenue Projections

Mark Booth	Individual income taxes
Hester Grippando	Customs duties, miscellaneous receipts
Carolyn Lynch	Corporate income taxes, Federal Reserve System earnings
Noah Meyerson	Social insurance taxes
Larry Ozanne	Capital gains realizations
John Sabelhaus	Estate and gift taxes
Sean Schofield	Excise taxes
David Weiner	Individual income taxes

Spending Projections

Defense, International Affairs, and Veterans' Affairs

Valerie Barton	Military retirement, veterans' education
Shawn Bishop	Veterans' health care, military health care
Kent Christensen	Defense (military construction, base closures)
Jeannette Deshong	Defense (military personnel, NATO expansion, and other international agreements)
Sunita D'Monte	International affairs (conduct of foreign affairs and information exchange activities), veterans' housing
Raymond Hall	Defense (Navy weapons, missile defenses, atomic energy defense)
Charles Riemann	Veterans' compensation and pensions
Dawn Sauter	Intelligence programs and defense acquisition reform
JoAnn Vines	Defense (tactical air forces, bombers, Army)

Joseph Whitehill International affairs (development, security, international financial institutions)

Health

Tom Bradley Medicare
 Jeanne De Sa Medicaid, State Children's Health Insurance Program
 Cynthia Dudzinski Public Health Service, Medicare
 Dorothy Rosenbaum Medicaid, State Children's Health Insurance Program

Human Resources

Valerie Baxter Food Stamps, child nutrition
 Sheila Dacey Child Support Enforcement, Temporary Assistance for Needy Families
 Deborah Kalcevic Education
 Justin Latus Education, foster care, child care
 Josh O'Harra Human resources
 Carla Pedone Housing assistance
 Eric Rollins Federal Civilian Retirement, Supplemental Security Income
 Kathy Ruffing Social Security
 Christi Hawley Sadoti Unemployment insurance, training programs, aging programs

Natural and Physical Resources

Gary Brown Water resources, other natural resources, regional development
 Kim Cawley Energy, pollution control and abatement, Universal Service Fund
 Clare Doherty Transportation
 Mark Grabowicz Justice, Postal Service
 Kathleen Gramp Energy, science and space, spectrum auction receipts
 Mark Hadley Commerce, credit unions
 Victoria Heid Conservation and land management, Outer Continental Shelf receipts
 David Hull Agriculture
 Craig Jagger Agriculture
 James Langley Agriculture
 Kristen Layman Transportation, Indian affairs, disaster assistance
 Mary Maginniss Deposit insurance, legislative branch
 Susanne Mehlman Justice, Federal Housing Administration and other housing credit
 David Moore Spectrum auction receipts
 Deborah Reis Recreation, water transportation, community development
 John Righter General government
 Philip Webre Universal Service Fund

Other

Janet Airis Appropriation bills
 Edward Blau Authorization bills
 Jodi Capps Appropriation bills
 Betty Embrey Appropriation bills
 Kenneth Farris Computer support
 Mary Froehlich Computer support

Vernon Hammett	Computer support
Jeffrey Holland	Net interest on the public debt
Catherine Mallison	Appropriation bills
Taman Morris	Other interest, civilian agency pay
Alex Roginsky	Computer support
Robert Sempsey	Appropriation bills
Jennifer Winkler	National income and product accounts