

214074

JPRS 81028

11 June 1982

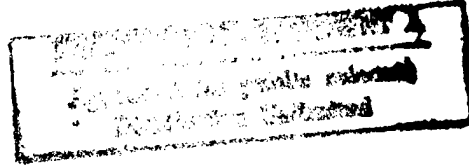

China Report

SCIENCE AND TECHNOLOGY

No. 164

19980902 146



FOREIGN BROADCAST INFORMATION SERVICE

164

NOTE

JPRS publications contain information primarily from foreign newspapers, periodicals and books, but also from news agency transmissions and broadcasts. Materials from foreign-language sources are translated; those from English-language sources are transcribed or reprinted, with the original phrasing and other characteristics retained.

Headlines, editorial reports, and material enclosed in brackets [] are supplied by JPRS. Processing indicators such as [Text] or [Excerpt] in the first line of each item, or following the last line of a brief, indicate how the original information was processed. Where no processing indicator is given, the information was summarized or extracted.

Unfamiliar names rendered phonetically or transliterated are enclosed in parentheses. Words or names preceded by a question mark and enclosed in parentheses were not clear in the original but have been supplied as appropriate in context. Other unattributed parenthetical notes within the body of an item originate with the source. Times within items are as given by source.

The contents of this publication in no way represent the policies, views or attitudes of the U.S. Government.

PROCUREMENT OF PUBLICATIONS

JPRS publications may be ordered from the National Technical Information Service, Springfield, Virginia 22161. In ordering, it is recommended that the JPRS number, title, date and author, if applicable, of publication be cited.

Current JPRS publications are announced in Government Reports Announcements issued semi-monthly by the National Technical Information Service, and are listed in the Monthly Catalog of U.S. Government Publications issued by the Superintendent of Documents, U.S. Government Printing Office, Washington, D.C. 20402.

Correspondence pertaining to matters other than procurement may be addressed to Joint Publications Research Service, 1000 North Glebe Road, Arlington, Virginia 22201.

JPRS 81028

11 June 1982

China Report

SCIENCE AND TECHNOLOGY

No. 164

FBIS

FOREIGN BROADCAST INFORMATION SERVICE

CHINA REPORT
SCIENCE AND TECHNOLOGY

No. 164

CONTENTS

PEOPLES' REPUBLIC OF CHINA

NATIONAL DEVELOPMENTS

National Science Publications Conference Held
(XINHUA Domestic Service, 22 May 82)..... 1

Briefs
Beijing Technicians' Refresher Courses 3

APPLIED SCIENCES

Views on Development of Science, Technology Aired
(Yang Zhenning; GUANGMING RIBAO, 5 Mar 82)..... 4

U.S. Nuclear Scientist Lectures in China
(GUANGMING RIBAO, 16 Feb 82)..... 7

Neutron Transmutation Doping Technique Developed
(GUANGMING RIBAO, 10 Mar 82)..... 9

New Electronic Equipment
(DIANZI JISHU, No 1, 1982)..... 10

Science, Technology Leads Production in Machine Industry
(Liu Yuxiang; SHAANXI RIBAO, 7 Feb 82)..... 15

Scientific Research Applied to Production
(Li Yuqiao; SHAANXI RIBAO, 11 Feb 82)..... 17

Article Describes Method of Automation
(Xu Tieling; JIXIEGONGYE ZIDONGHUA, No 1, 1982)..... 19

Briefs		
Computers, Demography		24
False Color Density Separator		24
Precision Polisher Developed		25
94 GHz Radiotelescope Developed		25
SCIENTISTS AND SCIENTIFIC ORGANIZATIONS		
Laser Conferences Held in Chongqing, Dalian (JIGUANG, Mar 82).....		26
General Applications, Popularization, by Ji Zhong Applications in Chemistry, by Ji He		
ABSTRACTS		
ARMAMENTS		
BINGGONG XUEBAO [ACTA ARMAMENTARII], No 2, May 82.....		29
AUTOMATION		
ZIDONGHUA XUEBAO [ACTA AUTOMATICA SINICA], No 2, 1982.....		31
EARTHQUAKE ENGINEERING		
DIZHEN GONGCHENG YU GONGCHENG ZHENDONG [EARTHQUAKE ENGINEERING AND ENGINEERING VIBRATION], No 1, 1982.....		32
ENGINEERING		
HUAZHONG GONGXUEYUAN XUEBAO [JOURNAL OF HUAZHONG UNIVERSITY OF SCIENCE AND TECHNOLOGY], No 2, 1982.....		33
ENGINEERING THERMOPHYSICS		
GONGCHENG REWULI XUEBAO [JOURNAL OF ENGINEERING THERMO- PHYSICS], No 2, May 82.....		34
EPIDEMIOLOGY		
LIUXINGBINGXUE ZAZHI [CHINESE JOURNAL OF EPIDEMIOLOGY], No 2, 20 May 81.....		35
FLIGHT MEDICINE		
JIEFANGJUN YIXUE ZAZHI [MEDICAL JOURNAL OF CHINESE PEOPLE'S LIBERATION ARMY], No 2, Apr 82.....		39

IRON AND STEEL

GANGTIE [IRON AND STEEL], No 4, 1982..... 41

MECHANICS

LIXUE XUEBAO [ACTA MECHANICA SINICA], No 2, 1982..... 43

OCEANOLOGY

SHANDONG HAIYANG XUEYUAN XUEBAO [JOURNAL OF SHANDONG COLLEGE
OF OCEANOLOGY], No 1, 1982..... 45

SCIENTIFIC INSTRUMENTS

YIQI YIBIAO XUEBAO [CHINESE JOURNAL OF SCIENTIFIC
INSTRUMENT], No 2, 1982..... 47

UNDERWATER RESEARCH

HAIYANG XUEBAO [ACTA OCEANOLOGICA SINICA], No 1, 15 Jan 82..... 48

VACUUM TECHNOLOGY

ZHENKONG [VACUUM], No 2, 25 Apr 82..... 50

NATIONAL DEVELOPMENTS

NATIONAL SCIENCE PUBLICATIONS CONFERENCE HELD

OW240043 Beijing XINHUA Domestic Service in Chinese 0108 GMT 22 May 82

[Text] Beijing, 22 May (XINHUA)--At a recent national conference on research and planning of popular science writing and a recent forum on research in popular science readers, it was pointed out that at present, China's popular science writing is flourishing with unprecedented vigor. But at the same time, some works with evil intent and poor quality and some others whose contents are even erroneous or poisonous, have appeared. The conference maintained that it is necessary to sum up experiences and lessons, strengthen theoretical studies and ideological guidance, vigorously popularize science, recommend to the public fine popular science readers, and criticize sub-standard or erroneous works, thereby raising the quality of popular science readers to meet the needs of the four modernizations.

To raise the level of popular science readers, the China Institute for Research in Popular Science Writing under the China Association for Science and Technology plans to edit and publish, in the next 2 years, some 12 selected popular science readers in basic science, engineering science and technology, agricultural science and technology, medicine and public health, military science and technology, new and developing science and technology, popular science for children, scientific literature, scientific news, scientific broadcasting, science education films and foreign popular science readers. In addition, part-time research personnel and research personnel by correspondence will be engaged to study the selection of subjects and help promising writers industriously create high-quality popular science works.

It is learned that in recent years, each year over 80,000 medium-length and short popular science works have been published in the nation's various popular science papers or magazines or broadcast in radio popular science programs, and over 1,500 popular science readers have been published. Their readers and listeners run into the hundreds of millions. All this has played an active role in raising the scientific and technological level of cadres and the masses, promoting scientific and technological undertakings and building the socialist material and spiritual civilization.

Representatives at these meetings fully affirmed the orientation and achievements of popular science research over the past year and more, proposed and recommended many subjects for research in popular science

and enthusiastically shouldered the task of research. Research subjects included the study of the history of popular science and various works on popular science as well as special studies on activities of noted Chinese and foreign scientists and popular science writers in promoting science and technology. The China Institute for Research in Popular Science Writings will formulate research plans according to the importance and urgency of subjects and has decided to edit and publish a large collection of "popular science works and research," which will carry related research theses.

CSO: 4008/175

NATIONAL DEVELOPMENTS

BRIEFS

BEIJING TECHNICIANS' REFRESHER COURSES--Beijing, 23 May (XINHUA)--Beijing has established a new college to provide refresher courses to scientific, technical and managerial personnel in the capital. Famous bridge expert Mao Yisheng is president of the college, which now has an enrollment of 2,400. Students come from among the 130,000 scientific and technical personnel working in institutions and enterprises under the Beijing Municipal Government. The college will provide them with professional knowledge and new developments in their fields of studies. Professors and teachers from Beijing's colleges and universities are invited to teach in the college. Preparations for establishing the college began in 1979. Some courses were started in the past 2 years and 1,800 students have already completed their studies there. [Text] [OW250439 Beijing XINHUA in English 1204 GMT 23 May 82]

CSO: 4008/175

APPLIED SCIENCES

VIEWS ON DEVELOPMENT OF SCIENCE, TECHNOLOGY AIRED

Beijing GUANGMING RIBAO in Chinese 5 Mar 82 p 2

[Article by Yang Zhenning [2799 2182 1337]: "Some Opinions on the Development of Science and Technology in China"]

[Text] Editors' Note: This article is extracted from a recent letter from Professor Yang Zhenning, who agreed to its publication after making a few corrections. We hope that the article will be given serious consideration by scientists in this country, and we welcome opinions on the problems raised.

Research work in the physical sciences being conducted in the various systems in China is tending toward two extremes: it either overstresses basic research or overstresses product research (manufacture and improvement). It seems that development research, which falls between these two types, has not been taken seriously enough.

In terms of its contribution to society, basic research is a long-term investment whose results may perhaps strengthen social productive forces in 30-50 years or 100 years (high energy physics research is a classic example of basic research); product research is a short-term investment which mainly aims at results that can strengthen productive forces within 1-2 or 3-5 years (semiconductor institute research, as I understand it, is aimed primarily at product research). These two types of research certainly have their uses to society. But development research is a mid-term investment which hopes for results that will strengthen the social productive forces within 5, 10 or 20 years. I believe that this type of investment is currently the weak link in China's scientific research system.

In terms of research objectives, basic research does not concern itself with applications, while product research is clearly focused on one or two products or types of products; the objective of development research falls between these two types and lays particular emphasis on applications, but it is not limited to one or two types of products which are already known to be producible.

The relationships between these three types of research can be shown in the following diagram:

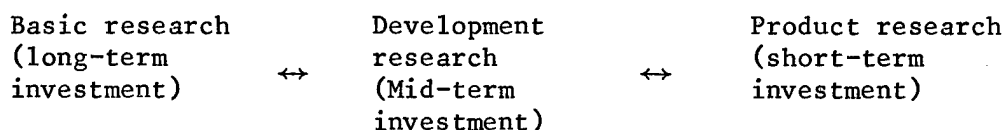

I believe that China needs a new, effective research center for developmental physics. Many scientific researchers of Chinese origin in the United States agree with this view.

The United States experience. In the United States today, basic research and development research are referred to together as "research and development" (R&D). Research is carried on primarily in universities and some national research institutions, while development is carried on primarily by research institutes associated with large corporations.

The following are some well-known corporate research laboratories (engaged primarily in development research): Bell Laboratories, General Electric Research Laboratories, duPont Laboratories, IBM Research Laboratories, Exxon Research Laboratories.

These laboratories have a great effect on United States industrial development, and total expenditures of development research are very great: According to statistics, the total operating expenditure of development research in the United States is about 10 times the operating expenditure of basic research. (See the article by A.T. Waterman, the first director of the National Science Foundation, in the AAAS publication "Symposium on Basic Research." Because the definitions of the two quantities being compared cannot be made entirely clear, this ratio cannot be estimated with any great accuracy.) This is a figure worth noting and considering: it indicates that other than product research, the bulk of United States scientific research expenditures go for development research.

Results in basic research gain great prestige and publicity, but the various corporations consider development research to be proprietary and are unwilling to publish it, so we in China may get the incorrect impression that basic research expenditures in the United States are greater than development research expenditures. In reality the situation is just the opposite.

The United States already had vigorous industrial development in the last century; but at that time the importance of research had not been recognized, so all research results were imported from Europe. It was the beginning of the 20th century before several large U.S. corporations began to recognize that this method would not do and created industrial research laboratories. Bell Laboratories, General Electric Research Laboratories and duPont Laboratories were all created during that period (see F. Seitz, "Science, Government and the Universities"; Seitz was head of the National Academy of Sciences before Handler). These laboratories not

only had a decisive effect on the United States' industrial development in this century, but even more important, their achievements made the United States' industry, commerce, banking and government recognize the importance of development research.

Support of basic research by society in the United States began only in the 1930's. This sequence of historical development puts the practical ahead of the theoretical and puts the near-term and mid-term ahead of the long-term:

Industrial development ↔ Development research ↔ Basic research
(began early in the (began about 1900) (began about 1950)
last century)

This was determined by economic laws and was not a matter of chance.

The same economic laws governed Japan's scientific and technical development. Japan's industrial takeoff in the last 30 years was based primarily on the results of development research and product research. There is very little expenditure on basic research in Japan.

The size of research centers. The United States company research centers mentioned above are very large. For example, today Bell Laboratories has a staff of 12,000 scientists and engineers, 3,000 of whom are PhD's (equivalent to more than 5 years of research experience after graduation from college).

The questions of what size a research center for developmental physics in China should be, what subjects it should focus on, with what plants, research institutes and universities it should cooperate, how it should train its research personnel, to what ministry or ministries it should belong (i.e., which ministry of machine building) and where it should be located are questions to which foreigners cannot contribute any useful opinions. A small conference should be held in China to study these questions in detail and propose a 5-year plan and a 10-year plan to be used in decision making.

Why are United States corporate research laboratories successful in development research? I believe there are three reasons:

- a. The companies are thoroughly aware that the research laboratories are their lifeline for 5, 10 or 15 years hence, so that the laboratories are given sufficient funds and good equipment and their treatment is generally better than that in university or government organizations;
- b. The laboratories' operating funds come from the corporations, and the ultimate value of their research results is determined by whether or not they can earn large profits for the corporations; this value concept is in accord with economic law;
- c. The laboratory management (many of whom are scientists and engineers, although there are also people with financial and legal backgrounds) have many years of experience and are relatively well able to judge what topics will affect the company's development in 5 or 10 years.

APPLIED SCIENCES

U.S. NUCLEAR SCIENTIST LECTURES IN CHINA

Beijing GUANGMING RIBAO in Chinese 16 Feb 82 p 1

[Article: "Professor Ding Zhaozhong Makes a Scholarly Report in Beijing"]

[Text] On his current visit to Beijing, eminent U.S. physicist Professor Ding Zhaozhong [0002 5128 0022] ignored fatigue to give his scholarly report according to plan.

Executive Chairman of the CAS Presidium and Director of the Graduate School Yan Jici [0917 3444 1964] chaired the report meeting on the morning of 6 February. He said that Professor Ding was an internationally known physicist, an eminent professor of the Chinese Scientific and Technical University and a famed scholarly member of the Institute of High Energy Physics who has showed great concern for the development of high energy physics in his ancestral country, making one trip a year to describe worldwide development in high energy physics, has made an energetic effort to promote cooperation with Chinese physicists, and has trained many young research workers in high energy physics for our country.

At the meeting, Professor Ding used a multitude of illustrations and data to give a detailed description of the experimental plans made during the past 2 years by the group which he leads at CERN [European Center for Nuclear Research] for the up-to-date LEP electron-positron collision installation that is about to be built. More than 10 countries, including European countries, the United States and China, are represented in the group.

Drawing on his rich experience, Professor Ding gave a detailed description of the development of high energy physics experimentation, presenting some advanced, unique detector designs. He started by stressing that there must be a clearly-defined physical objective as a point of departure for planning of physics experiments. He stated that priorities must be clearly established, that the experiment must assure attainment of the main objective, and that it must have its own specific characteristics. In the LEP experiment, he believes that the detection and analysis of photons and of leptons, such as electrons and muons, is the main objective. Strong currents will be measured at the same time. In order to assure that the main objective will be achieved, Professor Ding stressed the necessity of using the most advanced techniques.

In his report, Professor Ding also gave some views on how to reorganize large-scale physics experiments. He said that for an experimental team to achieve results, it must have good personnel and the physicists must be interested in the work and have an objective; once an objective is decided upon, it must be maintained over dissenting views and there should be no haggling over other opinions or opposition; they must persist in the search for scientific truth in the experiment. A struggle must be waged to win time for the experiment and to give it top priority. In organizational work, the fault of "too many cooks" must be overcome and a high level of efficiency must be maintained.

Participants in the meeting included China's renowned physicists Zhang Wenyu [1728 2429 5940], Zhu Hongyuan [2612 3163 0337], Zhao Zhongyao [6392 1813 1031], Xie Jialin [6200 1367 7792], Hu Ning [5170 1337] and Tang Xiaowei [0781 1321 1218].

8480

CSO: 4008/120

APPLIED SCIENCES

NEUTRON TRANSMUTATION DOPING TECHNIQUE DEVELOPED

Beijing GUANGMING RIBAO in Chinese 10 Mar 82 p 3

[Article: "Technique for Neutron Transmutation Doping of Silicon"]

[Text] Last December, the Ministry of Metallurgy, the Second Ministry of Machine Building and the First Ministry of Machine Building jointly held an evaluation meeting on a technology for neutron transmutation doping of power switching transistors, at which it gave a favorable evaluation of a technique developed jointly by the Emei Semiconductor Materials Research Institute, the Nuclear Power Research Institute (Chinese Academy of Sciences) and the Xi'an Institute of DC Devices.

Neutron transmutation doping is a new technique developed in the 1970's which produces neutron transmission doped (NTD) silicon. The main technical characteristic of NTD silicon is that it is far superior to n-doped silicon produced by conventional methods.

The NTD silicon technique developed jointly by the Emei Semiconductor Materials Institute, the Nuclear Power Research Institute and the Xi'an Institute of DC Devices has already reached the batch production stage.

The evaluation meeting concluded that the process used for production of the silicon starting material was capable of stable production of high quality silicon monocrystals suitable for NTD doping, that the neutron transmutation doping technique used in a light water reactor was similar in quality to that performed in foreign reactors of the same type; that the use of NTD silicon involved virtually no change in conventional processes and in the stable production of switching transistors; and that the NTD silicon produced by the process was of good quality. NTD silicon is used primarily in the manufacture of high-power switching transistors, rectifiers and medium and low power triodes and diodes. Devices made from NTD silicon had good uniformity and considerably improved characteristics and yields.

Those requiring more information are requested to contact the Nuclear Power Research Institute, Chinese Academy of Sciences.

8480

CSO: 4008/120

APPLIED SCIENCES

NEW ELECTRONIC EQUIPMENT

Shanghai DIANZI JISHU [ELECTRONIC TECHNOLOGY] in Chinese No 1, 1982 pp 43-44

[Article: "Introduction to New Products"]

[Article by Shou Gengru [1108 1649 1172]: "Questions and Answers About the S903 Antenna Amplifier"]

[Text] I. What is the use of the S903 Model VHF Antenna Amplifier produced by the Shanghai Radio Instruments Plant?

As the name implies, the S803 [sic] antenna amplifier is a television signal amplifier. It amplifies television signals received by the antenna and transmitted to the television set. It can visibly strengthen television signals severely weakened by the long distance between transmission and reception, and it can effectively compensate for the signal loss received by the outdoor antenna, transmitted over a long distance to the television set. It enables the signal to satisfy the requirements for signal amplitude by the television set. The quality of the image is improved. Background noise of the screen is reduced. The picture is clear and stable and the colors are bright.

II. Can the gain of the antenna amplifier be made higher?

The answer is negative. When we consider the gain of the amplifier, we must at the same time consider stability, especially the requirements of the low noise coefficient. This is because when the gain of the amplifier is too high, it will create self-excited oscillation and this destroys the normal operating state of the amplifier, and the quality of the image worsens. In addition, when the amplifier amplifies useful television signals, it must similarly amplify the noise that enters the amplifier and the internal noise of the amplifier. When the gain of the amplifier is too high, the value of the ratio between signal and noise (S/N) at the output end of the amplifier will drop. The quality of the television image will not improve too much. Therefore, the gain of the antenna amplifier cannot be too high. Full consideration has been given to the gain, stability and noise coefficient of the S903 antenna amplifier. It has a satisfactory noise coefficient, an ideal stability and a sufficiently large magnitude of amplification. The frequency range of the S903 is 45 to 230 MHz (1 to 12 frequency channels). The range of the input electrical level is 40 to 65 microwatts decibel (100 microvolts to 2 millivolts). The transmission impedance is 300 ohms or 75 ohms. The standing wave coefficient is below 3.

III. When the amplifier box and the power source box are installed at different places, do they need an additional power feed line?

The amplifier box and the power source box of the S903 antenna amplifier installed at different places do not need an additional power feed line. This is because the power feed line of the amplifier shares the 75 ohm coaxial cable or the 300 ohm dual parallel lines originally used to transmit the television signals, and because the frequency of the television signals and the frequency of the power source are very different. Electrically resistant elements can be used for insulation. The S903 antenna amplifier uses this measure. Their connections are illustrated in the following diagram.

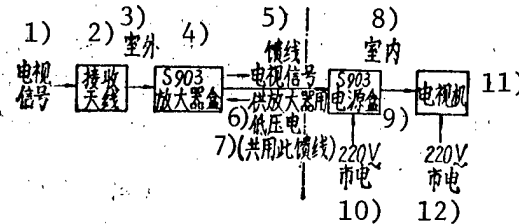

- Key:
1. Television signal
 2. Receiving antenna
 3. Outdoor
 4. S903 amplifier box
 5. Feed line
 6. Low voltage for amplifier
 7. (Share this feed line)
 8. Indoor
 9. S903 power source box
 10. 220V city power supply
 11. Television set
 12. 220V city power supply

IV. How is it installed?

After purchasing the S903 antenna amplifier, one can connect it as shown in the accompanying explanation and instruction diagram. The amplifier box can be affixed about 1 meter away from the antenna on the antenna pole by any type of clamp. Attention must be paid to treating the unbalanced 75 ohm transmission line and the 300 ohm balanced transmission line differently. Then, the switch of the power source box is thrown. The power source indicator light will light up indicating that the antenna amplifier has been connected to the power source.

V. Why does the S903 antenna amplifier have to be installed on the outdoor antenna pole?

The S903 antenna amplifier is designed for outdoor use. According to theoretical calculations, the total noise $F_{tot}(KT_0) = F_a + F_r - 1/G_a \cdot D$ according to the connecting order of antenna \rightarrow antenna amplifier \rightarrow long feed line \rightarrow television set. According to indoor design, the total noise $F_{tot}(KT_0) = 1 + F_a - 1/D + F_r - 1/G_a \cdot D$. In comparison, when the noise index F_a of the antenna amplifier, the gain G_a of the

antenna amplifier, the internal noise index F_r of the television set, the loss D of the feed line are the same, the total noise of the former is much smaller than the latter. Therefore, the S903 antenna amplifier designed as an outdoor amplifier produces the best results.

VI. What is the actual result?

As long as it is installed according to the explanation and instruction booklet, generally speaking, its results are outstanding within a radius of 50 to 80 km from the television transmission station. The Jinshan County Government Hostel in the remote suburbs of Shanghai is 65 km from the Shanghai Television Station. After installing the S903 antenna amplifier, the hostel was able to view color television programs transmitted on channel 5 by the Shanghai Television Station for the first time. The picture was clear and the colors were bright.

[Article by Wu Yinan [0702 1355 0589]: "81-1A Digital Logic Tester"]

[Text] The 81-1A digital logic tester (inside front cover) is a portable multi-functional logic tester designed and finalized by the Computer Science Department of Huadong Normal University. It is suitable for use by colleges and universities and middle vocational schools in instructional experiments of digital circuits, digital logic, microprocessors and automation. It is also suitable for use by computer science research units and factories in circuit testing and testing medium and large-scale integrated devices. The product passed evaluation in July, 1981, by more than 20 higher educational institutions and related factories. It has begun batch production by the Jiangsu Qidong Changjiang Electronic Instruments Plant. It has produced good results in use by many higher educational institutions.

The 81-1A digital logic tester has the following characteristics:

1. It consists of nine blocks of advanced multiple socket circuit boards assembled in a building block manner for plugging in medium and large-scale integrated circuits for testing.
2. It has a 1 Hz-1 MHz pulsed signal source. The pulse frequency and pulse width can be adjusted.
3. It has an overload protected (automatic restoring) voltage stabilized power source (i.e., +5 volts, +10 volts, -5 volts, as mutually independent power sources).
4. On the face panel is installed an eight-digit logic electrical level switch and an eight-digit logic electrical level indicator lamp with a drive.
5. It has a single pulse, clear "0" function keys and detachable logic test pen, digital display and a small multiple circuit switch.

[Article by Geng Ru [2577 0320]: "New S102 Model Combined Counter"]

[Text] The electronic frequency counter and the radio signal source are frequently used measuring instruments. In most applications, both machines have to be brought along. This is inconvenient to the user. Now, the functions of the two machines have been rationally combined together in the S102 multipurpose signal source/frequency counter which has been successfully developed on a trial basis by the Shanghai Radio Instruments Plant and it has begun batch production. A new instrument with good performance has been provided for testing and instructional experiments at factories manufacturing television sets, radios, communication devices, schools and scientific research units.

The S102 can produce high frequency waves, amplitude modulated waves, frequency modulated waves and pulsed waves in separate frequencies between 1 Hz and 250 MHz. It can also directly measure the frequencies of radio signals from 400 KHz to 125 MHz. Its highest sensitivity is better than 10 millivolts. Reading of the frequency of the signal source is performed by the counter and is directly displayed while counting. The reading is clear and reliable, and the traditional imprecision caused by errors in graduations and reading errors of the signal source has been eliminated.

The external shape of the S102 instrument is shown in the diagram. Its dimensions are 220 x 78 x 280 (millimeters) and it weighs only 3.5 kilograms. It consumes 12 watts of electricity and its power supply can be alternating current or direct current.

[Article by Shou Gengru [1108 1649 1172] and Zhu Xiu [2612 0208]: "Aishi Brand Electronic Counter"]

[Text] The Aishi brand electronic counters designed and manufactured by the Shanghai Radio Instruments Plant have many varieties and a full range of functions. There are mainly the following kinds:

The PS-43 digital frequency counter that can directly count up to 100 MHz (inside back cover); the PS-44 frequency counter and the PS-45 general purpose counter (inside back cover) that can directly measure 300 MHz, 500 MHz respectively; the S800 series portable electronic counter. This series includes the S801, S802, S805 and S807 frequency counters (inside back cover) which can directly count 100 MHz, 300 MHz, 500 MHz and 700 MHz respectively. The sensitivity of the various electronic counters is all better than 100 millivolts. The daily stability of crystal-line resonance is 3×10^9 /day. Insertable accessories used in combination with the above series of electronic counters to expand their functions include: the PK-1A frequency converter that can widen the frequency testing range of the PS-43 to 1000 MHz; the CPS-101 time interval testing unit for expanding the testing functions of the PS-45 (time interval, cycles, frequency ratio); and the CPS-201 frequency expansion unit that enables the mainframe PS-45 to reach a highest testing frequency of 1 gigahertz. There are also the CPS-301, S-00001 pre-amplifiers which can improve the sensitivity of the Ps-44, PS-45 and S810 so that it becomes better than 10 millivolts, totaling 20 varieties of products.

The design of the S810 electronic counter produced by that plant combines printed circuit board techniques with all domestically manufactured elements in the high speed circuits. This has improved the direct frequency testing ability of our nation's electronic counters to 1 gigahertz. The S812 precise time counter used to measure the distance between an artificial satellite and the earth has measured the distance with an error of less than ± 15 centimeters when combined with a laser radar to measure distances larger than 2000 kilometers. The instrument has a high resolution, a high precision, and its major technological specifications have approached the international level. The PK-2A frequency expander (inside back cover) that used a series of new techniques in circuit design, system structure and cavity processing can improve the upper limit of frequency measurements of a mainframe PS-45 connecting it to 4.5 gigahertz. There are also various portable and combined electronic counters that have been designed and manufactured according to the requirements of users, such as the S102 multipurpose signal source/frequency counter (inside back cover). The S102 combined instrument is light and versatile, convenient to use, and it is especially suitable for mobile users.

[Article by Li Fuyu [2621 1381 1342]: "Brief News on VMOS Field Effect Tube Development"]

[Text] The Semiconductor Physics Research Laboratory of the Shanghai Science University began to study the VMOS field effect tube in September of 1979. After over a year of efforts, it solved a series of key technical problems and successfully developed a new type of electronic device called the "longitudinal channeled VMOS high frequency and high speed power transistor" which possesses both the superior characteristics of the bipolar tube and the planar MOS tube. It passed evaluation as a scientific and research achievement in April of 1981. This device is tolerant to high voltage, has a small leakage, has a good transconductance linearity, and stable voltage when switched on. Also, it does not produce a second puncture phenomenon. Its major and typical parameters are as follows:

Leakage source puncture voltage	$BV_{DS} \geq 70$ volts
Bias voltage tolerance between grid and source	$BV_{GS} \geq 70$ volts
Maximum leaking pole current	$I_{Dmax} \approx 500$ milliamperes
Transductance	$g_m \approx 50-80$ milliohms
Gate voltage value	$V_T \leq 2.5$ volts
Electrical resistance to conduction	$R_{On} \approx 10$ ohms
Power gain	$K_p \approx 9$ dB (400 MHz)
Maximum output power	$P_o \approx 2.5$ watts (400 MHz)
Switching time	$t_{On}t_{ff} \approx 2-4$ millimicroseconds

The VMOS high frequency and high speed power transistor can be used as a high speed switch, on-off switched power source, on-off amplifier, power switch, ultrahigh frequency wide band amplifier, pre-step of a receiver, radio frequency amplifier and as the large current junction in CMOS and TTL logic circuits. The shortcoming of the device is that the electrical resistance to conduction and the large current voltage drop are large.

APPLIED SCIENCES

SCIENCE, TECHNOLOGY LEADS PRODUCTION IN MACHINE INDUSTRY

Xi'an SHAANXI RIBAO in Chinese, 7 Feb 82 p 2

[Article by Liu Yuxiang [0491 0056 7534]: "Shaanxi Heavy Machinery Plant Insists that Science and Technology Lead Production, Quality of Products Is Improved, and Production Value and Profits Continue to Climb Year After Year"]

[Text] The Shaanxi Heavy Machinery Plant insisted on the policy of science and technology leading production, greatly strengthened research of new products, expanded the scope of services and realized visible economic results. The production value and profits continued to climb year after year and a definite rate of development was maintained.

After the 3rd Plenum of the 11th Party Congress, this plant included scientific and technological work in the important daily agenda, and clearly proposed guiding policies in scientific and technological work for the whole plant, establishing the major tasks. Engineering technicians were assigned to the leading groups of the major production shops. The technology and science office was reorganized according to the principle of specialization. The system of technical management was perfected and over 200,000 yuan of capital raised by itself was used to add experimental equipment, strengthening the means of research and testing. A technical responsibility system headed by the chief engineer (technical deputy plant manager) was established. At the same time, the plant held an exhibition of scientific and technical achievements. These have encouraged scientific and technical personnel and collectives who have shown outstanding achievements in work, and greatly mobilized the enthusiasm of engineering and technical personnel and the masses toward science. Since 1979, they sent nine plant cadres to lead the engineering and technical personnel to visit north China, eastern China, the south central, northwest and southwest regions, and some localities within the province to survey over 200 users of the plant's products in the light industry, farm machinery industry, building materials industry and transportation industry. They also conducted technical and economic analysis of over 40 key users. Then they organized technical forces to strive toward better quality and to improve the inner quality and external quality of medium- and small-sized steel rollers on the original foundation, reorganized old products to lift the grades and, for replacement, developed 44 new types of steel, researched and tested 26 new types of products that were good in quality but low in cost, that had new structures and that were

easy to operate and repair. They have been well received by the users at each locality. The improvement in quality and the increase in products have enabled the production value and profits to climb continuously year after year and the enterprise has become active.

[Article by the Survey and Research Office of the Provincial Science Committee: "Baoji Petroleum Pipe Factory Greatly Develops Technological Renovation--In 2 Years It Has Realized 111 Renovation and Rebuilding Projects"]

[Text] The Baoji Petroleum Pipe Factory fully utilized presently available equipment, capital and materials to greatly develop technical renovation and technical improvements in improving the quality of products, reducing consumption, comprehensive utilization and in expanding varieties of products, and changed the serious passive situation of not having enough production tasks.

Baoji Petroleum Steel Pipe Factory mainly produces hidden arc screw welded steel pipes, nearly 50 types of steel pipes of different specifications and 2 types of welding agents. As the national economy is readjusted and as the battlefront of capital construction is shortened, the need for the products of this plant has drastically dropped and the production tasks have been seriously insufficient. Facing this fact, this plant relied on science and technology, began from within the enterprise and sought other ways by developing potential, renovation and rebuilding. The plant allocated 45 percent of the annual funds for renovation of the enterprise for use in technical renovation and technical improvements, and used its plant facilities to establish such major technical strengths of the scientific research institute, technical department and production shop in a relatively centralized fashion as a cooperative effort to study problems. All levels subordinate to the plant established leading groups in developing potential, renovation and improvement, and organized study groups. Engineering and technical personnel who were young and strong and who had experience were assigned to the front line of production to let them be in charge of concretely solving important technical problems in production. The plant also held 56 classes in various specializations to train backbone technical personnel to develop technology and renovation. Because the leadership paid attention and because the measures were correct, for the past two years the plant has realized 111 projects of renovation and improvements, and the quality of the products has visibly improved. In 1980, the percentage of products passing inspection reached 98.88 percent. First grade products amounted to 98.08 percent. The hidden arc screw welded steel pipes also received the national quality silver award. Last year the higher authorities issued a production plan to produce 40,000 tons, but the actual contract amounted to 62,000 tons. The production task increased from the original state of starvation to having too much work, and the passive situation of not having enough production tasks has been completely changed.

9296

CSO: 4008/107

APPLIED SCIENCES

SCIENTIFIC RESEARCH APPLIED TO PRODUCTION

Xi'an SHAANXI RIBAO in Chinese 11 Feb 82 p 1

[Article by Li Yuqiao [2621 3768 1564] of the Technology Department of the Provincial Economic Committee: "Being the Matchmaker Between Scientific Research and Production, Changing the Possession of One Unit Into Something 100 Units Can Use"]

[Text] The provincial economic committee and the provincial trade union have jointly organized technical cooperation between the factories and the technical cooperation office to apply scientific research achievements of scientific research units, universities and colleges and those enterprises with a strong technical force in production. This has changed the possession of one unit into something for use by 100 units and their strong life force has been demonstrated.

For over half a year, technical studies and transplants of technology have been organized especially for the production of 10 types of consumer goods of the light industry and textile industry. Nearly 100 enterprises solved more than 150 technical problems in production.

Our province now has 39 colleges and universities with strong scientific research strengths. There are more than 39 scientific research agencies that have relatively advanced instruments and equipment and that occupy a leading position in the nation. A fairly large number of them are nationally famous and unique specialized scientific research units. There are also over 200 large and medium backbone enterprises and a group of military enterprises that have relatively complete varieties and relatively strong technical strength, and the total number of scientific and technical personnel is over 195,800. They constitute our province's greatest advantage. But in the past, because the distribution of technical forces was not even, because the scientific and technical forces were not developed as well as they should have been, and because of a lack of channels and bridges for mutual communication between scientific research units and production units, scientific research and production were "two separate sheets of hide" and "flowers inside the wall produced fruits outside the wall." According to incomplete statistics, over the past 3 years 1,558 scientific achievements were realized throughout the province, but only 30 percent were applied and popularized in production. If this asymmetric situation between the scientific research strength and productive gain is not solved, it will be difficult for industrial production to shake away from the backward situation. Immediately after the

founding of this cooperative agency, the Provincial Technical Cooperation Office, it began studying technology, transplanting of technology, technical consultation and technical services to serve as the matchmaker between scientific research work and production and to bridge the gaps, and it has won the approval of all sectors and has been welcomed. For example, this office used the "801" dripping type thin layer carburization technique developed by the Provincial Machinery Academy at the Xi'an Bicycle Plant No 2. This has changed the long procedure, low efficiency, large energy consumption and high cost of the old kerosene dripping type carburization technique for carburizing the surface of bicycle axles. Consumption was lowered by 30 percent, the amount of electricity used was lowered by 26 percent, and the quality of products visibly improved. In the annual production of these four types of axle parts, calculating at 5.2 million pieces a year, the new technique can conserve over 16,000 yuan a year. After the close of the evaluation meeting for the two new techniques "801" and "803," the Provincial Technology Cooperation Office held a 4-day training class to popularize them among 32 enterprises in the light industry and textile industry. At present, the office has also accepted the commission of the State Economic Planning Commission and is preparing to hold short training classes to popularize the techniques in more than 150 key light industrial enterprises.

The Provincial Technology Cooperation Office has also organized the Tongchuan Technology Cooperation Office to help the Fuxian Brick Factory solve five difficult production techniques to fire bricks by positive pressure, to increase baking length, to adjust ventilation, etc., so that the percentage of imperfect products can be reduced from 80 percent to below 2 percent. Work efficiency has been improved 1.4 times. Over 10,000 yuan can be conserved a year in coal and electricity costs. A "dead factory" that was about to be closed down was rescued. During the past 6 months and more, it has also held 43 technical seminars of various kinds. Ten thousand persons attended. Fifty-one classes of various technical training classes were held and over 3,000 people participated.

At present, Xi'an, Baoji, Tongchuan and Xianyang prefectures and cities have already established corresponding technology cooperation organizations and have established 32 specialized technical cooperation teams in heat treatment, welding, casting, electronics, painting, and metal cutting with over 3,000 team members. The development of technical cooperation is very encouraging.

9296

CSO: 4008/107

APPLIED SCIENCES

ARTICLE DESCRIBES METHOD OF AUTOMATION

Beijing JIXIEGONGYE ZIDONGHUA [MACHINE BUILDING INDUSTRY AUTOMATION] in Chinese No 1, 1982 pp 42-43

[Article by Xu Tieling [1776 6993 7881], vice chairman of the Automation Branch, Hunan Provincial Machinery Engineering Society: "Taking the Road of Automation in the Chinese Way"]

[Text] I. In today's world of developed science and advanced technology, automation and modernization are like "twins." Various production machinery, weapons and equipment, scientific instruments, etc., and modern equipment are almost all automated or semi-automated. Therefore, the standard of automation has become an important indicator to measure the degree of modernization of industrial and agricultural production, national defense and science and technology.

The Party Central Committee has proposed developing four modernizations in a Chinese style, therefore we must also develop automation in a Chinese style.

I. The lesson that should be learned in popularizing the technology of automation

1. Detached from the situation in the nation and unilaterally seeking "unmanned" operation

Our nation has a population of 1 billion. The reserves of the labor force are huge. Under this situation, blindly pursuing the development of "unmanned" facilities of industrially advanced foreign nations, and even developing "unmanned shifts" which do not involve complex operating conditions, "telemetry, remote communications, remote sensing and remote control," etc., have frequently wasted massive amounts of capital just to eliminate a few workers. Even when a few workers have been eliminated, the whole employment structure has not changed along with progress in modernization. The few workers who have been replaced are still a burden for the enterprises.

Take the automation of a drainage pump at a certain mine as an example. Because the amount of water emerging from underground was large, five drainage pump stations were set up in the pits. Each pumping station had six to seven 300- to 400-kilowatt shallow water pumps. Three to four pumps usually operated continuously in three shifts. Each shift was manned by two workers. To realize

starting and shutting off the water pumps, automatic operation of the reserve pumps and automatic rotation of operation among the pumps, various forms of fluviographs and relay control devices were installed. For this, investment in each water pumping station increased by nearly 10,000 yuan. Calculating at a conservation of four operators per pumping station, each year nearly 5,000 yuan in wages could be saved. Theoretical estimates showed that investment in the automated facilities could be recovered in 2 years. At the beginning of the 1970's, the equipment began production one after the other. No visible benefits were gained in production and, because of many intermediate links, the chances of breakdown of the pumps increased and there were more troubles in maintenance. The workers and the higher authorities were both dissatisfied and operation had to be changed back to manual operation. As a result, the effort did not really conserve manpower and a lot of manpower and materials was wasted. According to our understanding, most of the automated water pumping stations similar to this one throughout the nation have already been abandoned.

Also, for example, a certain enterprise had three 6-kilovolt high voltage power distribution rooms. Each power distribution room was equipped with 20 GG-1A model high voltage switching panels. To pursue automation, it selected and used the SF58-25/A model line selector type remote control and remote communications equipment manufactured by a certain plant in Shanghai to realize "unmanned operation" of the high voltage distribution rooms. Investment in the equipment was 70,000 yuan. Calculating at 15 workers for the 3 power distribution rooms, each year nearly 20,000 yuan in wages could be saved and it was estimated that the initial investment could be recovered in three and one-half years. Therefore, it was decided that the "unmanned" operation plan would be implemented. The facilities were tested and handed over to the production units for use in 1972 and they were abandoned not long afterward. The reason was that the operation of the high voltage power distribution rooms had to be reliable, but the connections of the SF-58 model products were complex. There were many chances for malfunction and the manufacturing standard could not realize "unmanned shifts." For an enterprise, power transformation and power distribution stations are vital departments. The operation must also be simple. With this background, who can implement "unmanned operation" without worries?

2. Aiming too high and blindly pursuing "high grade, precision, pioneering" technologies

China's technology in automation is relatively backward. The gap in electrical controls is even greater. Foreign nations have already widely utilized computers and microcomputers have already penetrated into the various fields of automation.

Several years ago, the "important craze" was widespread among various enterprises. The competitively demanded that foreign nations provide computer-centered fully automated technology. For this, China invested a lot of technical effort for technical preparations. Many research units proposed "optimal control," "variable control" and other such high grade, precision and pioneering research subjects. Because the conflicts within the productive processes of various enterprises in the nation were not analyzed in depth and in detail, "test points" that were

separated from the actual productive levels were established. Everyone wanted to "improve output through optimal control" or "improve quality through variable control." A lot of manpower was invested and a lot of capital was spent (including foreign exchange), but technical and economic results could not be realized for a long time.

II. Taking the road of automation in the Chinese way

1. According to China's plans to readjust the national economy, the emphasis on automation at present should be in the light and textile industries, development of energy resources and conservation, improvement of environmental pollution and protection of production safety, and in industries that will benefit the opening of international markets. At the same time, the machinery industry, electronics industry, petrochemical industries should thoroughly implement the policies of renovation, rebuilding and developing potential. The function of presently available automation facilities should be fully developed. Efforts should be organized to study automation equipment that have problems so that such equipment can be used normally in production. Some old equipment must be technically rebuilt to realize ordinary automation following the principle of spending less money to do more work. Popularization and improvement of automation should gradually progress in order to catch up and surpass the world's advanced levels step-by-step.

For this, we must establish policies to develop automation in relative stability. We must make plans that suit the situation in the nation, that combine the near-term and the long-term goals and that are practical and feasible. We must establish an organized system that includes development by division of labor and popularization of automation technology.

2. Every way must be sought and efforts must be exerted to realize automation of production posts that endanger workers' health, such as toxic environments, dangerous environments and labor intensive environments.

For example, electroplating operations seriously endanger workers' health because of pollution of the environment by toxic and corrosive gases. Such an environment is suited for using automated production lines.

Also, for example, automation of punches in punching shops, automated molding and transport lines in casting shops, automated operating lines for pouring, automated packaging of white arsenic should be developed greatly to summarize and popularize the results of automation technology in time.

3. The energy problem is the foremost problem in China's building of the four modernizations. In the near-term, conservation must be placed at the foremost position. Improvement of technology and techniques and renovation and replacement of equipment can be promoted via conservation. Technical improvement and structural renovation of the national economy should be centered around conservation.

China now has approximately over 200,000 medium and small boilers in operation. Coal measurements and control, measurements of the flow of steam and its control and load regulators that guarantee economical operation of the boilers should be developed in a big way and popularized as quickly as possible. Necessary automated regulation of temperature, pressure and combustion in kilns and heating furnaces and such large equipment that consume energy must be implemented to guarantee that they operate in the best operating state and conserve energy.

We must develop and popularize devices that automatically compensate for power factors. During this period of nationwide shortage of electricity, conserving wasted electric power and providing more useful electricity will contribute greatly to the development of the national economy.

The automatic control devices, such as silicon controlled series governors, should be popularized in a big way. The ventilators and pumps and other such fluidic machinery used by China's light industry, textile industry, building materials industry, petrochemical industry and metallurgical industry generally require speed adjustments with a 30 percent range. The power of the series governors is only one-third the specified power of transmission type electrical motors. Practice shows that the difficulty in realizing this type of speed regulation is small and it is easy to popularize. The present emphasis in application should be in the realm of automatic control of temperature in textile mills, water pumps of urban water companies and the various enterprises, speed regulation of ventilators of power plants and cement factories, and automatic speed regulation of the slurry pumps at mines.

4. Automation technology is a comprehensive technology. Developing automation technology requires the joint efforts of scientific research units, design units, manufacturing plants and user factories and mines before good results can be realized.

Because automation technology is a science that spans many professions and, at the same time, because it is a technology that changes every day, it is difficult to adapt to the development in automation technology by fighting alone. Therefore, the Automation Society should serve a greater function in the popularization of automation technology. Through the society, specialists in all fields can gather together to establish a practical and feasible plan for the development of automation technology on the basis of surveys and research. Forces must be organized to take charge of making key breakthroughs by division of labor according to the characteristics of different periods and different professions. When the conditions are mature, product evaluation meetings can be organized and technological exchange can be carried out in time for mutual promotion and mutual improvement. Forces must be organized for different needs to strengthen technological development and popularization in factories and mines. Specialized technical training should also be actively developed.

Manufacturing plants must establish the concept of "seeking survival through quality, seeking development through varieties." They should clearly see the trends of technological development, grasp the different requirements of the users in time, and exert efforts to provide high quality and low cost products and

satisfactory service for users. The greatest hindrance to the popularization of automation technology is the overly high price of automation devices, unreliable operation, and the massive amount of maintenance work. For this, manufacturing plants must develop product standardization, generalization and serialization in time.

9296

CSO: 4008/116

BRIEFS

COMPUTERS, DEMOGRAPHY--China will use 29 computers to process the massive amounts of data and information of its third national census. At present, each province, city and autonomous region are actively building the computer station. In the national census to be held of 1 July of this year, they will form a computer network centered in Beijing. The capital for 21 of these computers has been provided by financial aid from the United Nations Population Activity Fund. Eight computers have already been shipped and received. The remaining 13 computers will be shipped and will arrive in the near future. The eight computers purchased by China have already been installed separately in eight provinces, cities and autonomous regions and have processed data of local census test points. This is the first time China has used computers to process large-scale census data. To prepare well, over 1,000 people in computer software, hardware and operations and maintenance technicians have been chosen from all localities and they are now in training. One hundred thousand encoding and several thousand recording personnel will also be selected and trained to serve the computers. [Text] [Shijiazhuang HEBEI RIBAO in Chinese 2 Feb 82 p 3] 9296

FALSE COLOR DENSITY SEPARATOR--The photographs taken by satellites using multiple spectra remote sensing, photographs of isotope scanning in medicine, X-ray photographs of wounds suffered in industrial professions are all precious research data. But these are all black and white photographs and the images are not as clear and fresh as color photographs. At the end of last year, the Beijing Postal and Telecommunications Academy and the Atmospheric Physics Institute of the Chinese Academy of Sciences jointly developed a false color density separator which can change black and white photographs into color photographs. The photographs can display variations in topography and the position and degree of pathological changes in the human body in different colors. This facilitates accurate recognition of such changes. In the past, the false color density separator used in China was always imported. The false color density separator developed has reached the level of similar products of foreign nations in all its main functions. [Text] [Beijing BEIJING RIBAO in Chinese 9 Feb 82 p 1] 9296

PRECISION POLISHER DEVELOPED--Recently the YMP-1 precision grinder and polisher, developed jointly by the Rugao County No 5 Radio Plant, Jiangsu, and the Shanghai Institute of Technical Physics, Chinese Academy of Sciences, passed its technical evaluation. The evaluation results indicated that the machine documentation was rather complete, that it conformed to standardization norms, that the model was of novel and efficient design and compact in structure, that the quality of the parts and assemblies and of the entire machine met or exceeded the original design specifications, and that it could be used by a wide range of research units, universities and specialized schools and plant research laboratories for high-precision grinding and polishing of special crystalline materials and could be used in combination with X-ray diffraction equipment for polishing in alignment with different crystal directions. Potential users are requested to contact the Rugao (Jiangsu) County No 5 Radio Plant. [Text] [Beijing GUANGMING RIBAO in Chinese 10 Mar 82 p 3] 8480

94 GHz RADIOTELESCOPE DEVELOPED--The 94 GHz radiotelescope is mainly used to measure the absorption of radio waves of the 94 GHz frequency by the atmosphere and to conduct corresponding theoretical research. It can also be used for observing solar radio emissions and radio emissions of the moon at this frequency. The successful development of this radiotelescope has important significance in the development of national defense, remote sensing technology and research in radio astronomy. The sensitivity of this radiotelescope has reached the level of similar foreign equipment. The receiver consists of all integrated circuits. There are some new technologies which have also been used in this type of equipment for the first time in China. After actual observations, the performance of this radiotelescope is good and it has already received China's first group of actually observed data of atmospheric absorption of radio waves on the 94 GHz frequency. [Text] [Guangzhou YANGCHENG WANBAO in Chinese 1 Feb 82 p 1] 9296

CSO: 4008/107

SCIENTISTS AND SCIENTIFIC ORGANIZATIONS

LASER CONFERENCES HELD IN CHONGQING, DALIAN

General Applications, Popularization

Shanghai JIGUANG [LASER JOURNAL] in Chinese Vol 9 No 3, Mar 82 p 151

[Article by Ji Zhong [4764 6945]]

[Text] The National Laser Applications and Popularization Exchange Conference was held in Chongqing from 23-28 November 1981. Over 340 delegates from 270 units in 28 provinces, cities and autonomous regions, except the Xizang Autonomous Region and Taiwan Province, participated in this exchange conference. The conference received more than 400 papers and reports, and 144 of them were exchanged at the conference. The reporting meetings were held in five meeting rooms: (1) agricultural applications; (2) holography, measurements; (3) devices and components; (4) laser processing, heat treatment, inspection; (5) medical applications.

The reports received by the conference basically reflected the present situation and level of laser application in our nation. In industrial applications, the applied technologies of laser punching, laser welding, laser collimation, holographic non-destructive inspection were more mature, and definite economic results had been realized. Many watch component factories throughout China already used laser punchers to process gem bearings. The punching rate could reach 20 times per second. This reduced work procedures and improved work efficiency. Laser collimation realized achievements in the machine tool industry and bridge construction. When building the Changjiang Bridge in Chongqing, the laser collimator was used to collimate the bridge piers. This not only hastened the progress of construction, it also improved construction quality. The vertical error of the 70-meter tall piers of the bridge was only 2 millimeters. This was much smaller than the originally designed error of 8 millimeters. Holographic photography was used to solve some inspection problems that had been difficult to solve for a long time in production. For example, results were realized in the inspection of aircraft tires and in the detection of cracks in bomb shells and welded seams of liquefied petroleum gas canisters.

The laser demonstrator using a laser light source was used in educational demonstrations related to optics in the study of fundamental physics at middle schools and universities and it was welcomed by students and teachers. At present, our nation already has several fixed models of the laser demonstrator.

Medical workers reported on the clinical results of utilizing lasers. The laser is used a lot in clinical cases and it involves a broad scope. Reports included cases in otolaryngology and ophthalmology and stomatology, dermatology, gynecology and internal medicine. The large number of reports indicated that clinical use of lasers produced a definite result, and achievements were realized in treating some diseases with a low percentage of success with treatment by common surgical measures, such as excision of throat cancer and internal tumors in the liver.

The study of laser applications in agriculture was once developed on a broad scale in China, but such development dwindled over the past years. The delegates of the city science committee and the scientific and technical workers engaged in actual work discussed and exchanged views on the present situation in the popularization and application of lasers as well as the direction and policies of further popularizing the application of the laser.

During the conference, a laser science and technology achievement exhibition was held at the People's Arts Hall in Chongqing. Over 100 products produced by more than 40 research institutes, higher educational institutions and factories were exhibited. They included more than 30 commonly used laser devices, materials, components, stand-alone technologies and auxiliary equipment and various types of medical laser equipment. A large number of models and photographs showing the achievements of industrial applications was also exhibited.

Applications in Chemistry

Shanghai JIGUANG [LASER JOURNAL] in Chinese Vol 9 No 3, Mar 82 p 162

[Article by Ji He [0679 4421]]

[Text] The national conference on "Lasers in Chemistry" was held in Dalian City, Liaoning Province, from 12-15 November, 1981.

The conference was held in two phases. The first phase was the reporting conference which lasted a day and a half. A total of nine solicited reports were exchanged. They presented a relatively comprehensive discussion of domestic and foreign research trends and developments in laser chemistry, chemical lasers, the application of laser spectroscopy, laser induced chemical reactions, laser separated isotopes, application of lasers in chemistry and fluidic laser spectroscopy.

Afterward, special topic discussions by the following three groups were held: (1) chemical laser and gaseous and fluidic laser devices; (2) laser chemistry and microcosmic reaction dynamics; (3) laser technology in chemistry. The group meetings read more than 80 papers and conducted exchange and discussions on special topics in chemical lasers, laser induced chemical reactions, infrared multiple photon dissociation, laser separation of isotopes, laser spectroscopy and its application in chemistry, and new types of laser dyes. Profound and detailed fundamental research has begun in chemical lasers. Definite achievements

have been realized in light initiated, electron beam initiated and fluidic devices. Work in mathematical simulation of chemical lasers has begun. Research in the various means of testing is being carried out in depth. Welcomed results have also been realized in other realms of chemical lasers.

This was an academic exchange conference where chemistry and physics crossed paths and stimulated each other. Among the more than 140 delegates participating in this conference were scientific and technical workers in chemistry and scientific and technical personnel in physics. Their mutual cooperation and support will produce a profound and long lasting influence on this frontier science of lasers in chemistry.

9296

CSO: 4008/157

Armaments

AUTHOR: DONG Liang [5516 0081]
ZHANG Xun [1728 6598]
MA Suzhen [7456 4790 3791]

ORG: None

TITLE: "The Influences of Nonlinear Restoring Moments on the Motion of Fin-stabilized Projectiles"

SOURCE: Beijing BINGGONG XUEBAO [ACTA ARMAMENTARII] in Chinese No 2, May 82
pp 12-23

TEXT OF ENGLISH ABSTRACT: In this paper, we make use of the elliptic integral to solve the attack differential equation of a fin-stabilized projectile. The nonlinear restoring moments act on the fin-stabilized projectile which moves on a certain plane. Six conditions of stabilized periodic motions are given out and nonlinear restoring moments' effects on the projectile motion are detailed in this paper. The causes of the unexpected falling-down of mortar projectiles are discussed theoretically.

AUTHOR: DENG Shuyi [6772 6615 4448]
XU Zhimin [1776 2535 2404]
DU Lianfang [2629 6647 5364]
YANG Jianhua [2799 0313 5478]

ORG: None

TITLE: "Modulation Transfer Function of Human Visual System"

SOURCE: Beijing BINGGONG XUEBAO [ACTA ARMAMENTARII] in Chinese No 2, May 82
pp 24-33

TEXT OF ENGLISH ABSTRACT: The threshold modulation for detection of rectangular wave gratings was measured as a function of spatial frequency for six observers at the ages of 19~21 by an apparatus which has been developed in our laboratory. Data were obtained for white light at eight retinal illuminance levels. The modulation transfer function was then calculated from these results. Based on the systems theory and spectral analysis, the modulation transfer function provides the resulting description of the performance of human eyes and can be applied to optical engineering and clinical ophthalmology.

AUTHOR: LIU Xiuji [0491 0208 7535]

ORG: None

TITLE: "On the Weight Growth of Main Battle Tanks in the Future"

SOURCE: Beijing BINGGONG XUEBAO [ACTA ARMAMENTARII] in Chinese No 2, May 82
pp 42-53

TEXT OF ENGLISH ABSTRACT: The weight of the main battle tank increases continuously with the improvements in its three main performances--fire power, mobility and protection. This has become an acute problem for main battle tanks at the present time. In this paper, the objective regularity of the weight increase of main battle tanks in history is summarized, and the theoretical limit of the weight of tanks and whether the limit can be exceeded are discussed. The major aims of this paper are to analyze some directional foresights which will solve the problem of the weight increase of tanks from a long-term point of view. When the weight expands to a desperate situation, the final choice could be nothing but giving up some performances and giving prominence to other performances, which might lead to building different tanks for different uses. Some new concepts and arguments presented in this paper might help to clear up some questions and be useful as a reference in discussing the future of tanks.

9717

CSO: 4009/325

Automation

AUTHOR: TU Xuyan [3205 1645 7346]

ORG: Institute of Automation, Chinese Academy of Sciences

TITLE: "The Problem of the Structural Synthesis of the Most Economical Control Systems"

SOURCE: Beijing ZIDONGHUA XUEBAO [ACTA AUTOMATICA SINICA] in Chinese No 2, 1982 pp 103-111

TEXT OF ENGLISH ABSTRACT: In this paper, the ideas on the "Most Economical Control" and the "Most Economical Observation" are proposed, and the problem of the structural synthesis of the Most Economical Control System is discussed in detail. Starting from the multivariable "Harmonic Control" principle, the concepts of the "subtypes" of controllability and observability are introduced, and the related definitions and theorems are obtained. Based on them, the direct method of the Most Economical Structural Synthesis of linear time-invarying system is given and illustrated by two examples. Then, the open problems in the theory of the Most Economical Control Systems are mentioned.

AUTHOR: CAO Wenbin [2580 2429 1755]

ORG: Institute of Computer Technology, Hunan Province

TITLE: "Instantaneous Synchronous Method of Group Control in Real Time Remote Control Systems"

SOURCE: Beijing ZIDONGHUA XUEBAO [ACTA AUTOMATICA SINICA] in Chinese No 2, 1982 pp 126-135

TEXT OF ENGLISH ABSTRACT: This paper introduces a synchronous method of group control in real time remote control systems. Starting with the design of the structure of the instruction codes and pseudorandom codes in sequence, an instantaneous synchronous method of the system has been obtained in which the starting phase can float randomly.

The main features of this method are simplicity of circuit structure and reduction of time for synchronous tracking and synchronous holding existing in all the traditional synchronous methods, thus enabling the controlled objects to "respond rapidly and move accurately," and satisfy the requirements for the real time remote control.

Earthquake Engineering

AUTHOR: ZHANG Daming [1728 1129 0682]
LIN Weisong [2651 0251 2646]
WU Zhangzhu [0702 4545 3796]
LI Yuanheng [7812 0337 0077]

ORG: All of the Seismological Institute of Guangdong Province

TITLE: "Free Vibration of Tall Shear Wall Structures"

SOURCE: Dalian DIZHEN GONGCHENG YU GONGCHENG ZHENDONG [EARTHQUAKE ENGINEERING AND ENGINEERING VIBRATION] in Chinese No 1, 1982 pp 33-39

TEXT OF ENGLISH ABSTRACT: Based on the model tests, the dynamic tests of full-scale structures and the theoretical analysis, a practical method for calculating the free vibration of tall shear wall structures, is presented in this paper. Using this method, the natural periods and modes of two buildings are calculated. The results obtained are nearly coincident with those obtained in the tests.

AUTHOR: None

ORG: Coal Mines Planning and Design Institute, Ministry of Coal Industry

TITLE: "Damage to Structures and Installations in the Underground Excavations of the Kailuan Colliery During the Tangshan Earthquake"

SOURCE: Dalian DIZHEN GONGCHENG YU GONGCHENG ZHENDONG [EARTHQUAKE ENGINEERING AND ENGINEERING VIBRATION] in Chinese No 1, 1982 pp 67-76

TEXT OF ENGLISH ABSTRACT: Typical damage to structures and installations in the underground excavations of the Kailuan Colliery, such as shafts, stations, chambers, main roadways, panel roadways, extraction faces and tunnel supports, during the Tangshan Earthquake of 28 July 1976 is discussed. Analysis of damage shows that engineering geological conditions, geologic tectonics, characteristics of surrounding rock, forms of support, layout of roadways and workmanship of construction have a direct effect on the damage to structures and installations in the underground excavations. The paper also shows that a lot of roadways and equipment were flooded due to sudden increase of flow of underground water and the breakdown of the power supply during the strong earthquake induced a lot of serious secondary damage. Suggestions have been proposed for the aseismic design of underground mines in the seismic area, and aseismic measures have been taken.

Engineering

AUTHOR: LIANG Shufen [2733 3219 5358]
SUN Yibing [1327 0076 0365]

ORG: Both of Huazhong University of Science and Technology

TITLE: "Regressive Analysis of Hydrodynamic Coefficients for Horizontal Fin and Rudder Assembly in Submarines"

SOURCE: Wuhan HUAZHONG GONGXUEYUAN XUEBAO [JOURNAL OF HUAZHONG UNIVERSITY OF SCIENCE AND TECHNOLOGY] in Chinese No 2, 1982 pp 53-57

TEXT OF ENGLISH ABSTRACT: By a multivariate linear regressive analysis based on the data obtained from tests performed on a small series of models of submarine horizontal fin and rudder assemblies, a numerical analysis is carried out and formulas for hydrodynamic coefficients that can be used in designs are derived.

AUTHOR: SUN Yibing [1327 0076 0365]
LIANG Shufen [2733 3219 5358]

ORG: Both of Huazhong University of Science and Technology

TITLE: "A Numerical Method for Calculating Hydrodynamic Coefficients of Submarine Horizontal Stabilizing Fin-rudder Assembly"

SOURCE: Wuhan HUAZHONG GONGXUEYUAN XUEBAO [JOURNAL OF HUAZHONG UNIVERSITY OF SCIENCE AND TECHNOLOGY] in Chinese No 2, 1982 pp 59-66

TEXT OF ENGLISH ABSTRACT: Described in this paper is the calculation of hydrodynamic coefficients of a submarine horizontal stabilizing fin-rudder assembly by a numerical method of finite elementary solution. Calculation results are basically in agreement with those obtained by experiments. The effects of the aspect ratio, the swept-back, the taper ratio and the area ratio of the rudder itself to the whole assembly on the hydrodynamic coefficients are also studied.

9717
CSO: 4009/318

Engineering Thermophysics

AUTHOR: GAO Yaolin [7559 5069 2651]
LI Keming [2621 0344 2494]

ORG: GAO of Shenyang Aeroengine Company; LI of Shenyang Aeroengine Research Institute

TITLE: "Effect of the Rear Stage Casing Treatment on the Overall Performance of a Multistage Axial-flow Compressor"

SOURCE: Beijing GONGCHENG REWULI XUEBAO [JOURNAL OF ENGINEERING THERMOPHYSICS] in Chinese No 2, May 82 pp 131-134

TEXT OF ENGLISH ABSTRACT: A trouble shooting test progress report on "C" compressor is presented. It mainly describes the test results concerning the effects of casing treatment and varying the stagger angle of the rotor blades at stages 7, 8 and 9 on the overall performance of a multistage axial-flow compressor. The test results show that the casing treatment of the rear stages is a very effective method to extend the stable operating range of the compressor at high speeds.

AUTHOR: YAN Ruqun [0917 3067 5028]
QIAN Zhaoyan [6929 5128 8826]

ORG: Both of Northwestern Polytechnical University

TITLE: "Investigations of Performance of Swept Cascade of Axial-flow Compressor"

SOURCE: Beijing GONGCHENG REWULI XUEBAO [JOURNAL OF ENGINEERING THERMOPHYSICS] in Chinese No 2, May 82 pp 135-137

TEXT OF ENGLISH ABSTRACT: The aerodynamic performances of swept cascade of axial-flow compressors are researched in this paper, and the calculating methods of the coefficient of total pressure losses, critical mach number and turning angle of the swept cascade are provided.

The flow features of swept blade along span direction are also studied, and the average wake contours and experimental data of various locations in span direction at given operating conditions are presented.

9717
CSO: 4009/321

Epidemiology

AUTHOR: WENG Hongchun [5040 3163 2504]
ZHAO Yixin [6392 2011 6580]
PANG Zuozhang [1690 0155 4545]

ORG: All of Tienjin Municipal Public Health and Epidemic Prevention Station

TITLE: "Investigation of Epidemiological Characteristics of Typhoid Fever in Tienjin City in 1973-79 and Its Preventive Measures and Treatment"

SOURCE: Beijing LIUXINGBINGXUE ZAZHI [CHINESE JOURNAL OF EPIDEMIOLOGY] in Chinese No 2, 20 May 81 pp 77-81

ABSTRACT: In 1973, there began a high incidence of typhoid fever in the city of Tienjin and some nearby rural villages. Following preventive and treatment efforts, the rate of occurrence began to fall to a normal level [pre-1973 level] in 1979. The 2 serious epidemics of typhoid fever in that city in 1958-64 and in 1973-78 are analyzed. The amount of rainfall does not appear to be closely related to the spread of the disease. In the 50's and the early 60's, drinking water appears to be the important source of the epidemic, but as the source of drinking water in the city continues to be improved in recent years, the rate of cases following the use of water for drinking or swimming has declined steadily. The majority of the cases belong to the type caused through daily contact (72.8-79.2 percent in 1973-79) primarily due to failure of strict isolation of patients. The major preventive measures adopted during the epidemic of 1973-79 are discussed and evaluated.

AUTHOR: TONG Xurong [0157 2485 2827]
SUN Yazhou [1327 0068 3166]
HOU Jun [0176 0193]
PANG Qifang [1690 0366 5364]
CONG Lianren [1783 6647 0088]
LIU Mingyang [0491 2494 7122]
QIN Baochang [4440 1405 2490]
YANG Xiufeng [2799 4423 7364]
ZHU Chun [2612 4783]
SHAN Changshou [1472 2490 1108]
HE Zimin [0149 1311 2404]
LIU Chongbo [0491 1504 0130]
GAO Jinlan [7559 6855 5695]

ORG: TONG, HOU, LIU, SHAN of Fushun Municipal Public Health and Epidemic Prevention Station; SUN, PANG, YANG, ZHU, HE, LIU of Research Institute of Virology, Chinese Academy of Medical Sciences; QIN of Fushun Municipal Suburban Public Health and Epidemic Prevention Station; CONG of Fushun Municipal Infectious Disease Hospital; GAO of Fushun Municipal Suburban Huiyuan Commune Hospital

TITLE: "Report of An Epidemiological Survey of an Outbreak of Type A Viral Hepatitis"

SOURCE: Beijing LIUXINGBINGXUE ZAZHI [CHINESE JOURNAL OF EPIDEMIOLOGY] in Chinese No 2, 20 May 81 pp 89-91

[continuation of LIUXINGBINGXUE ZAZHI No 2, 1981 pp 89-91]

ABSTRACT: From the middle of Mar to the end of Aug, 1979, there was a small scale outbreak of hepatitis in Sandao Brigade in the suburb of Fushun City. The disease affected 82 persons. Epidemiological data, clinical manifestations, and pathogenic diagnoses all proved it to be an outbreak of A viral hepatitis, spread through group contact. The disease affected 7.88 percent of the population and the victims belonged to 57 families, amounting to 28.1 percent of the households in the brigade. Laboratory observation of feces of 4 patients disclosed that the virus may be detected from the feces from the end of the incubation period (the acute stage) all the way until after the appearance of jaundice. The titer and the duration of virus discharge varied from one individual to another in this group, however. All through this outbreak, the incubation period was short and the disease attacked chiefly children under 15 years of age. During the recovery stage, the positive rate of serum antibody reached 81.82 percent. Following treatment, all patients of this group were cured.

AUTHOR: HUANG Yulan [7806 3768 5695]
LI Junqing [2621 0193 7230]

ORG: Both of the 302 Hospital

TITLE: "Epidemiological Analysis of 1105 Cases of Malaria Observed in Beijing in the Recent 15 Years"

SOURCE: Beijing LIUXINGBINGXUE ZAZHI [CHINESE JOURNAL OF EPIDEMIOLOGY] in Chinese No 2, 20 May 81 pp 95-98

ABSTRACT: Beijing is a region of unstable and low malaria incidence. Local physicians give little attention to this disease, but as it is the capital of the country, there are many domestic and foreign visitors. In the 15 years between 1965 and 1979, 1105 malaria cases were admitted at the hospital. A very large majority of these patients were visitors. The number of cases rose apparently after 1969 and 1971 was the peak year. Generally speaking, there were more cases in the summer; about 1/3 of the patients had had a history of malaria and 3/4 of the patients had lived in a region of high malaria incidence. Almost all these cases were tertian malaria but there were also a few falciparum cases. Most cases had typical attack symptoms and positive blood smear. Treatment with antimalarial drugs was usually effective. Among the antimalarial drugs used, the chloroquine plus Primaquine regimen was found to produce the best effects and to be the safest as well.

AUTHOR: None

ORG: Hunan Provincial Research Institute of Prevention and Treatment of Parasitism; Changde, Yiyang, and Yueyang Region Schistosomiasis Prevention and Treatment Center; Yueyang Municipal Shimen County Schistosomiasis Prevention and Treatment Hospital; Yuanjiang County Sihushan Region Schistosomiasis Prevention and Treatment Hospital

TITLE: "Epidemiological Survey in Three Varieties of Epidemic Loci of Schistosomiasis in Hunan Province"

SOURCE: Beijing LIUXINGBINGXUE ZAZHI [CHINESE JOURNAL OF EPIDEMIOLOGY] in Chinese No 2, 20 May 81 pp 99-102

ABSTRACT: Since 1956, as the movement of prevention and treatment of schistosomiasis continued to progress, the condition of prevalence of this disease has changed. There are now 3 types of localities: (1) The epidemic ceased to occur and the prevention and treatment effects have become stabilized; (2) The area of distribution of oncomelania snails has shrunk and epidemics have become mild but there remain some victims and it is still possible for new cases to appear; (3) Snail distribution area remains large and epidemics severe. An area of each of these conditions was picked in 1979 to observe the epidemiological characteristics of the previous year. The survey results confirm that when the snail population is exterminated in an area, schistosomiasis ceases to spread there. The contents of the survey and an analysis of the result are reported.

AUTHOR: HUANG Baozhi [7806 1405 2655]

ORG: HUANG of Anhui College of Chinese Traditional Medicine; and Department of Epidemic Prevention, Hefei Municipal Public Health and Epidemic Prevention Station

TITLE: "Epidemiologic Analysis of Scarlet Fever of a 25-year Period in Hefei City"

SOURCE: Beijing LIUXINGBINGXUE ZAZHI [CHINESE JOURNAL OF EPIDEMIOLOGY] in Chinese No 2, 20 May 81 pp 109-112

ABSTRACT: In the past, scarlet fever was mostly a disease of North China. It was seldom observed in the south except for a few scattered cases in the Changjiang Valley. In the last 2 decades, there have been a few serious epidemics of scarlet fever in Hefei City, however, with a rate of 41.77/10,000 population in 1959, 108.22 in 1973 (45.75 in 1974) and 43.49 in 1979. The data of 1973 and 79 indicate that the youngest victim is 6-month of age and the oldest is 56 with the peak in 73 among the group of 7-12 years of age. Surveys disclose that the initial cases are usually visitors from Shanghai, Henan, and Jiangsu while a simultaneous epidemic is reported in Bangbu City with the peak occurring 6 months before the epidemics in Hefei. These epidemics are; therefore, obviously related. The authors did observe children coming to school with a rash. They suggest that active cases should be strictly isolated although the disease is easy to diagnose and specific and effective drug is available for cure.

AUTHOR: ZHANG Yangxi [4545 2254 3556]

ORG: Liaoning Provincial Public Health and Epidemic Prevention Station

TITLE: "Automation of Processing and Miniaturation of Reservoir of Epidemiological Data"

SOURCE: Beijing LIUXINGBINGXUE ZAZHI [CHINESE JOURNAL OF EPIDEMIOLOGY] in Chinese No 2, 20 May 81 pp 137-138

ABSTRACT: The application of computers in medicine has only been a recent subject but some studies on aspects of clinical diagnosis have produced some valuable results. This paper introduces the successful project, carried out by the author and colleagues, of using computer for statistical analysis of conditions of epidemics of infectious diseases. The general purpose computer TQ-16 made in China is used, with an operating speed of 110,000 calculations/second and a capacity of 32K. The program designed for the purpose of statistical grouping of fatal cases according to the time, the place, the age, and the occupation to produce various reports automatically is introduced. The advantages of making such reports with the computer are discussed.

6248

CSO: 4009/317

Flight Medicine

AUTHOR: YU Lishen [0060 4539 6500]
et al.

ORG: All of the Institute of Aviation Medicine, PLA

TITLE: "Prediction of Airsickness Susceptibility Among Flight Trainees with Coriolis Stimulation Test"

SOURCE: Beijing JIEFANGJUN YIXUE ZAZHI [MEDICAL JOURNAL OF CHINESE PEOPLE'S LIBERATION ARMY] in Chinese Vol 7 No 2, Apr 82 pp 69-72

TEXT OF ENGLISH ABSTRACT: The Coriolis (or cross coupled) stimulation test was used to assess the susceptibility to airsickness of 7,048 flight trainees and pilots. In the testing, it was emphasized that not only the endurance time but also the extent of vestibulo-vegetative nervous responses, e.g., nausea, facial pallor and cold sweat, should be closely observed instead of observing any one of them. In comparison with the record of actual flight training, those trainees who endured the test less than 90 sec and showed intensive vestibulo-vegetative nervous responses were highly susceptible to airsickness. Of these, 71-78 percent were graded as severe, and they were disqualified from participating in flight training. The test was considered to be a definite and significant improvement in predictability over former tests.

AUTHOR: ZHAO Guozhong [6392 0948 1813]
et al.

ORG: All of the Institute of Aviation Medicine, PLA

TITLE: "A Preliminary Report of the Prediction of Flying Ability with EEG"

SOURCE: Beijing JIEFANGJUN YIXUE ZAZHI [MEDICAL JOURNAL OF CHINESE PEOPLE'S LIBERATION ARMY] in Chinese Vol 7 No 2, Apr 82 pp 73-75

TEXT OF ENGLISH ABSTRACT: The EEG's of 625 physically qualified cadets of the Air Force Probationary Pilot Trainee School were analyzed and classified into types. A year later, before graduation from primary flight training, the cadets had their EEG's examined once more, and a careful analysis was made pertaining to flying ability. It was found that most of the subjects with high frequency α waves (12-13 c/s), classified as types II-2, IV-1 and IV-2, had had higher percentages of grounding and lower flying ability, and most of the subjects with medium frequency α waves (9.5-11.5 c/s), classified as types I and III, had had lower percentages of grounding and higher flying ability. Thus, it is considered that in selection of pilots, in collaboration with physical and psychological examinations, those subjects with medium frequency α waves (types I and III) should be given priority over those with EEG types II-2, IV-1 and IV-2.

AUTHOR: ZHAO Min [6392 3046]

ORG: Fourth Military Medical College, Xian

TITLE: "An Experimental Evaluation of Low Pressure Altitude Chamber Flight Profile Used for Indoctrination of Flying Personnel"

SOURCE: Beijing JIEFANGJUN YIXUE ZAZHI [MEDICAL JOURNAL OF CHINESE PEOPLE'S LIBERATION ARMY] in Chinese Vol 7 No 2, Apr 82 pp 76-79

TEXT OF ENGLISH ABSTRACT: In order to improve our current chamber flight profile used in high altitude indoctrination, we studied the physiological effects of altitude hypoxia and decompression on 300 subjects. They were subjected to chamber flights with atmospheric pressure corresponding to a height of 11,000 m, inhaling either pure oxygen or nitrogen-oxygen mixture, the ratio of the latter corresponding to an altitude of 7,500 m. The experimental results confirmed that our new profile possesses many advantages, such as better acquainting the fliers with the symptoms of hypoxia and decompression, economizing manpower, material and time, etc. Moreover, this flight profile can also be used to check the fliers' hypoxic tolerance more efficiently.

AUTHOR: XUE Shanyi [5641 0810 4135]
AN Dingyi [1344 1353 0001]

ORG: Both of the General Hospital of the Air Force, PLA

TITLE: "Responses to Coriolis Acceleration in Airsick Pilots"

SOURCE: Beijing JIEFANGJUN YIXUE ZAZHI [MEDICAL JOURNAL OF CHINESE PEOPLE'S LIBERATION ARMY] in Chinese Vol 7 No 2, Apr 82 pp 80-82

TEXT OF ENGLISH ABSTRACT: Two groups of pilots, one normal and the other with airsickness, were subjected to Coriolis acceleration with closed eyes. Their responses, including vertigo, palpitation, feverishness, weakness, salivation, pallor, sweating, nausea and vomiting, etc., were recorded. All data were collected and analyzed. All these responses observed were categorized into four degrees by the double-blind method combined with score recording. The responses in the airsick group were much different statistically than those of the normal group. At the same time we obtained a critical line of responses with which we are able to distinguish the abnormal from the normal, and also evaluate the individual adaptability in flying. Anyone who shows only mild responses can go on flying. On the other hand, those who show excessive responses beyond the critical line, and are identified or diagnosed as airsick, are certainly to be disqualified. When compared with the general rotatory test, the Coriolis method was more reliable. But the final evaluation must be considered with the history of motion and practical flying life of the subject undergoing the test.

Iron and Steel

AUTHOR: ZHANG Yansheng [1728 1750 3932]
WANG Mingxian [3769 2494 6343]
ZHAO Xuejun [6392 1331 6511]
XU Yikui [6079 5030 1145]
PIAO Kaidong [2613 0418 2639]

ORG: ZHANG, WANG, ZHAO and XU all of the Institute of Metal Research, Chinese Academy of Sciences; PIAO of Fushun Steel Works

TITLE: "Study on a New High Strength Heat-resisting Steel 45Mn31A13Mo2VWNbB"

SOURCE: Beijing GANGTIE [IRON AND STEEL] in Chinese No 4, 1982 pp 45-52

TEXT OF ENGLISH ABSTRACT: This paper describes briefly the experimental results of Ni-Cr free austenitic high strength heat-resisting steels. The results show that there exists the possibility of developing an austenitic Fe-Mn-Al high temperature steel with high strength and a new experimental steel, 45Mn31A13Mo2VW NbB, has been successfully produced. Its structure and properties have been systematically studied by metallographic, electrolytic analysis, phase extrusion and mechanical testing methods. It is found that V_4C_3 , NbC and Laves phase, etc., exist in this steel, with V_4C_3 being the chief strengthening phase.

The precipitation hardening of V_4C_3 combined with solid solution strengthening of Mo and W gives the steel high endurance strength exceeding that of A-286 in the

[Continuation of GANGTIE No 4, 1982 pp 45-52]

in the range of 700-800°C and approaching the level of Nimonic 80A. However, their resistance to oxidation and corrosion is poor, thus it is necessary to aluminize it to warrant long time service at relatively high temperatures. It is also pointed out that this steel may be produced on an industrial scale by inexpensive techniques and can withstand the commercial competition with Cr-Ni austenitic steel.

AUTHOR: MO Shuchi [5459 0647 6688]
QIU Chunrong [0092 2504 2837]

ORG: MO of the Central Iron and Steel Research Institute; QIU of Baotou Iron and Steel Company

TITLE: "A Comprehensive Study of the Production and Application of Fe-Nb-Mn Alloy"

SOURCE: Beijing GANGTIE [IRON AND STEEL] in Chinese No 4, 1982 pp 53-58

TEXT OF ENGLISH ABSTRACT: Using an open hearth furnace slag containing about 0.5 percent Nb_2O_3 as raw material, a new Fe-Nb-Mn alloy containing 16 percent Nb, 5 percent Mn has been developed. It can be used effectively as a micro-alloy additive in steelmaking. The alloy effect of Nb in steel can be brought into full play in controlled rolling, and gives steel products a good combination of properties. A small amount of this additive in alloy cast iron will refine the matrix structure, improve the mechanical properties and prolong the service life. Furthermore, the recovery of niobium is stable (85 percent).

9717
CSO: 4009/320

AUTHOR: WANG Dajun [3769 1129 6874]
 HU Haichang [5170 3189 2490]

ORG: WANG of the Department of Mechanics, Beijing University; HU of the Institute of Spacecraft System Engineering, Chinese Academy of Space Technology, and the Department of Mechanics, Beijing University

TITLE: "A Unified Proof for the Positive Definiteness and Compactness of Two Kinds of Operators in the Theory of Elastic Structure"

SOURCE: Beijing LIXUE XUEBAO [ACTA MECHANICA SINICA] in Chinese No 2, 1982 pp 111-121

TEXT OF ENGLISH ABSTRACT: In the theory of leastic structures such as beams, plates and shells, we may define three kinds of spaces on the function space of all possible displacements: a Hilbert space of square integrable $\bar{U}_{\Delta\Delta} = L_2(F)$ which has $U_{\Delta\Delta} = \mathcal{D}(A_{\Delta})$, the domain of definition of the "Structure Theory Operator" A_{Δ} , as its subspace; an inner product space U_{ps} whose norm equals the square root of the strain energy Π_{Δ} of the structure, together with its complete space \bar{U}_{ps} ; and a Hilbert space \bar{U}_{ks} whose norm equals the square root of the kinetic energy K_{Δ} of the structure. The operators $T_{ps,\Delta\Delta}: U_{ps} \rightarrow U_{\Delta\Delta}$ and $T_{ps,ks}: \bar{U}_{ps} \rightarrow \bar{U}_{ks}$ are then defined as mappings between the same elements in two different spaces.

The purpose of this paper is to prove that A_{Δ} is positive definite (which is equivalent to $T_{ps,\Delta\Delta}$ being bounded) and that $T_{ps,ks}$ is compact.

[Continuation of LIXUE XUEBAO No 2, 1982 pp 111-121]

On the other hand, the elastic structure may be dealt with as an elastic body with three dimensions. In three-dimensional elasticity, three corresponding kinds of spaces are defined on the function space of displacements: \bar{U}_{se} and U_{se} ; U_{pe} and \bar{U}_{pe} ; and lastly \bar{U}_{ke} . The operators $T_{pe,se}$ and $T_{pe,ke}$ are similarly defined. It is known in the literature that the "Elasticity Operator" A_e is positive definite (i.e., $T_{pe,se}$ is bounded) and $T_{pe,ke}$ is compact for quite a wide range of boundary conditions.

Generally, there exist three connections in mechanics between the structural theory and elasticity: (i) The displacements in structural theory may be taken as the displacements in elasticity imposed with certain constraints described by the equality $u = T_{\Delta\Delta,se} w$, where the operator $T_{\Delta\Delta,se}$ maps $U_{\Delta\Delta}$ onto a subspace U_{se}^r of U_{se} ; (ii) In structural theory, usually there are some assumptions about the stress state, so that there exists a connection between Π_{Δ} and strain energy Π_e^r in elasticity theory with the same displacements. This shows that the operator $T_{ps,pe}: U_{ps} - U_{pe}^r$ is bounded, the correspondence between the elements of $T_{ps,pe}$ being the same as that for $T_{\Delta\Delta,se}$; (iii) In structural theory, the contribution of some displacement components to the kinetic energy is often omitted, so we have a third connection between K_{Δ} and the kinetic energy K_e^r in elasticity, which shows that the operator $T_{se,\Delta\Delta}$, the inverse operator of $T_{\Delta\Delta,se}$, is bounded.

The following conclusions are obtained by two auxiliary functional theorems:

[Continuation of LIXUE XUEBAO No 2, 1982 pp 111-121]

For a structure with given boundary conditions, if the corresponding boundary conditions of the elastic body ensure the positive definiteness of the operator A_e , then the operator A_s with the given boundary conditions is also positive definite.

If such boundary conditions ensure the compactness of the operator $T_{pe,ke}$, then the operator $T_{ps,ks}$ is also compact.

In particular, these conclusions are applicable to composite structures as well as to shells with boundary conditions of various types, such as fixed edge, hinged edge, free edge, movable edge in the direction normal to the middle surface and their combinations.

AUTHOR: PAN Liangru [3382 5328 0320]
YAN Zhongmin [0917 6945 2404]

ORG: Both of the Institute of Mechanics, Chinese Academy of Sciences

TITLE: "The Viscous Effects on an AC MHD Power Generator"

SOURCE: Beijing LIXUE XUEBAO [ACTA MECHANICA SINICA] in Chinese No 2, 1982
pp 195-201

TEXT OF ENGLISH ABSTRACT: This paper discusses viscous effects on the electrical performance and flow field of an AC MHD power generator. The analytical expressions for power factor, electrical fields and viscous incompressible flow in an AC MHD generator with channel height $2a$ and wave length λ are calculated to order $2a/\lambda$ by the usual method of expansion in powers of $2a/\lambda$. It is found that viscous effects have to be taken into account when ϵ is not quite small and equivalent

Hartman number $M \sin \left(\frac{2\pi}{\lambda} x - \omega t \right) \leq 0(10)$.

9717
CSO: 4009/310

Oceanology

AUTHOR: ZOU Xingchang [6760 5281 7022]

ORG: Department of Marine Physics

TITLE: "Analysis of Data from Passive Microwave Remote Sensing over the Jiaozhou Bay, Qingdao"

SOURCE: Qingdao SHANDONG HAIYANG XUEYUAN XUEBAO [JOURNAL OF SHANDONG COLLEGE OF OCEANOLOGY] in Chinese Vol 12 No 1, 1982 pp 21-26

TEXT OF ENGLISH ABSTRACT: The passive microwave radiometric images were taken from the test field over Jiaozhou Bay, Qingdao, with an airborne 3-centimetric imaging microwave radiometer in September and October, 1979. In this paper, we present some microwave radiometric pictures and analyze the remote sensing data obtained, with a brief discussion of oceanography microwave remote sensing. From these pictures and analysis it is shown that the distribution of the brightness temperature of salt field differs distinctly from that of estuarine environment.

AUTHOR: None

ORG: Laboratory of Ocean Optics, Department of Marine Physics

TITLE: "Analyzing the Results of an Airborne Test for Remote Sensing over Jiaozhou Bay"

SOURCE: Qingdao SHANDONG HAIYANG XUEYUAN XUEBAO [JOURNAL OF SHANDONG COLLEGE OF OCEANOLOGY] in Chinese Vol 12 No 1, 1982 pp 27-34

TEXT OF ENGLISH ABSTRACT: The Shandong College of Oceanology organized an airborne test of remote sensing over Jiaozhou Bay in the last week of September, 1979. This paper mainly discusses our analytic methods and analyzes data and information gained from our test. We have analyzed data from this test, and obtained several results: (a) Hydrologic information of the sea, (b) Pollution of the sea, (c) Coastal geomorphology, (d) The rmal radiation image at night, (e) Microwave radiation from the sea surface.

AUTHOR: HE Mingxia [6320 2494 7209]
LIU Zhishen [0491 2535 3088]
QIU Zhen [3061 4176]

ORG: All of the Department of Marine Physics

TITLE: "Real-time Optical Information Processing for Ocean Remote Sensing Images"

SOURCE: Qingdao SHANDONG HAIYANG XUEYUAN XUEBAO [JOURNAL OF SHANDONG COLLEGE OF OCEANOLOGY] in Chinese Vol 12 No 1, 1982 pp 35-38

TEXT OF ENGLISH ABSTRACT: This paper describes a white light image processing system using a new optical method for oceanic remote sensing images. Landsat photographs and airborne remote sensing images of Chinese coastal areas have been processed. The experimental results show that this technique is very appropriate for practical application in coastal zone survey, for example, for length of coastal line, shoal patch in shallow sea areas, silt distribution of river mouth, ocean surface pollution as well as analysis of sea current and ocean waves.

9717

CSO: 4009/312

Scientific Instruments

AUTHOR: QIN Shaozong [4440 4801 1350]
LIU Guangyuan [0491 0342 3293]

ORG: Both of the Institute of Chemical Metallurgy, Chinese Academy of Sciences

TITLE: "The Applications of Optical Fiber Transducer in Measurement and Display"

SOURCE: Beijing YIQI YIBIAO XUEBAO [CHINESE JOURNAL OF SCIENTIFIC INSTRUMENT]
in Chinese No 2, 1982 pp 129-136

TEXT OF ENGLISH ABSTRACT: This paper describes the results of the experimental study in which optical fibers are used as a transducer to measure the velocity of solid particles, the porosity in two-phase flow, the phase surface in the flow medium and to display the images of the solid particles in the reactor. The structures of several types of optical fiber probes are introduced and a statistical distribution device for measuring bubble diameter and velocity is designed.

This paper also gives the diagrams of probability density distribution which was obtained by applying the random signal statistical method to analysis of the experimental data.

AUTHOR: LIANG Fuping [2733 4395 1627]

ORG: Tianjin University

TITLE: "An Investigation of Diameter Measurement of Superthin Wire with Laser Diffraction Waves"

SOURCE: Beijing YIQI YIBIAO XUEBAO [CHINESE JOURNAL OF SCIENTIFIC INSTRUMENT]
in Chinese No 2, 1982 pp 211-218

TEXT OF ENGLISH ABSTRACT: This paper introduces the method of using laser diffraction to measure the diameter of superthin wire and studies the problems of small signals, weak energy and many disturbances that appeared in the diffraction measurement of superthin wire. According to the theoretical computation of the distribution of energy of the diffraction pattern and the symmetrical principle of energy, calculation and analysis for how to set the receiving diaphragm is made. Based on the result of theoretical analogous computation by computers, an "analogous method of moving the detector" has been submitted for calibration. The method and its theoretical and experimental curve have been analyzed and introduced.

9717
CSO: 4009/323

Underwater Research

AUTHOR: ZHU Jimao [2612 4949 2021]
ZHAO Yuanjie [6392 0337 0253]

ORG: Both of Shanghai Transportation University

TITLE: "Experimental Research on Maneuvering A Self-propelled Submersible Model"

SOURCE: Beijing HAIYANG XUEBAO [ACTA OCEANOLOGICA SINICA] in Chinese Vol 4 No 1,
15 Jan 82 pp 114-137

ABSTRACT: This paper reports an experiment of maneuvering a quarter scale self-propelled submersible model, telecontrolled by radio. The model has a displacement of one ton and is 3.8 m x 0.65 m in size. The maneuver operations, on horizontal and vertical planes and including hovering, lateral translation, turning on the spot, and mating with another object underwater, are performed in a towing tank. Special characteristics of the ducted propeller are analyzed. A drawing depicting the geometric dimensions of the model (Fig. 1) and another depicting its overall arrangement are included. The legend for Fig. 2 is as follows: (1) Vertical propeller motor; (2) 20AH silver-zinc storage battery; (3) 45AH silver-zinc storage battery; (4) Vertical tilt adjustment system; (5) Telemetric and recording instruments; (6) Telecontrol component; (7) Ballast tank; (8) Main propeller; (9) Side propeller electric motor; (10) Butt skirt; (11) Side propeller; (12) Vertical propeller; (13) Main propeller electric motor; (14) Main propeller speed reducer; (15) Rotary jacket; (16) Cabin entrance and exit cover; (17) Telecontrol antenna.

[continuation of HAIYANG XUEBAO Vol 4 No 1, 1982 pp 114-137]

Figs 1 and 2 are reproduced in the following:

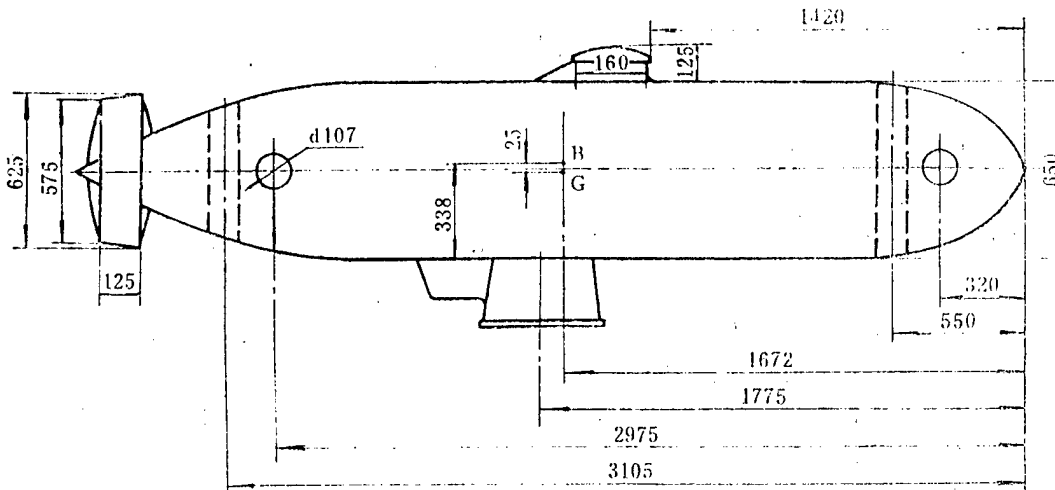

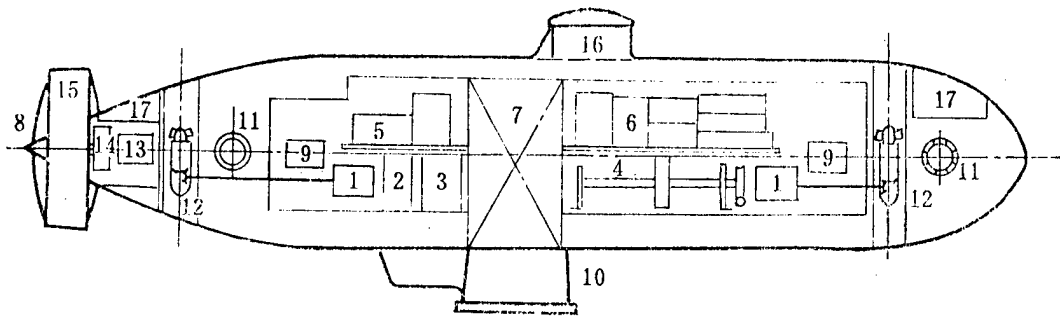

This paper was received for publication on 25 Jun 80.

6248
CSO: 4009/314

AUTHOR: CHEN Longzhi [7115 7127 2535]

ORG: Lanzhou Research Institute of Physics

TITLE: "Attainment and Application of Superfines"

SOURCE: Shenyang ZHENKONG [VACUUM] in Chinese No 2, 25 Apr 82 pp 42-46

ABSTRACT: At present, among Chinese vacuum technology circles the application of ultra-high vacuum to acquire superfines remains an unfamiliar subject. This paper intends to be a brief introduction of the characteristics, the method of attainment, and the range of application of superfines. Research studies on making superfines began in earnest in the 60's but it was not until 1979 when French and Japanese scientists reported independently their success in using silver superfines as a new heat exchange material for dilution refrigeration with a work temperature range of 10^{-2} - 3×10^{-3} K. The strange properties of metal, nonmetal, and chemical compound superfines are introduced, as well as the history of acquiring superfines from mechanical pulverizing, supersonic disintegration, low temperature comminution, vacuum freeze drying, and chemical reduction method of pulverizing, etc. The contribution of W. German scientists in improving both the condensation process and the vacuum technique and the fact that Japan leads the world in superfines technology by producing one ton a year in 1980 are mentioned.

AUTHOR: HAN Gang [7281 0474]

ORG: 71 Mirror Manufacturing Plant, Changping County, Beijing

TITLE: "New Process of Vacuum Aluminum Plating Introduced in Producing Mirrors for Civilian Use"

SOURCE: Shenyang ZHENKONG [VACUUM] in Chinese No 2, 25 Apr 82 pp 62-inside back cover

ABSTRACT: For a long time the silver plating technique has been used to make mirrors for civilian use and a large quantity of silver nitrate is used up for this purpose. The mirror industry is actually consuming nearly 50 tons of silver a year. Under the current condition of low silver production level and high cost, it has become necessary to replace silver with aluminum. The process and requirements of vacuum aluminum film plating technique of making mirrors are introduced. Due to the unstable nature of glass itself and the change of season, high temperature and humidity, etc. in the process of transportation, it is necessary to pretreat the glass before plating. There are several pretreating methods. The choice of the pretreatment method most suitable for the available plating machine and other production conditions constitutes the major production problem at present.

6248

CSO: 4009/315

END