

R
350104

JPRS 82008

18 October 1982

USSR Report

CONSTRUCTION AND EQUIPMENT

No. 75

19980911 096

DISTRIBUTION STATEMENT A

Approved for public release;
Distribution Unlimited

FBIS

FOREIGN BROADCAST INFORMATION SERVICE

7
40
A03

NOTE

JPRS publications contain information primarily from foreign newspapers, periodicals and books, but also from news agency transmissions and broadcasts. Materials from foreign-language sources are translated; those from English-language sources are transcribed or reprinted, with the original phrasing and other characteristics retained.

Headlines, editorial reports, and material enclosed in brackets [] are supplied by JPRS. Processing indicators such as [Text] or [Excerpt] in the first line of each item, or following the last line of a brief, indicate how the original information was processed. Where no processing indicator is given, the information was summarized or extracted.

Unfamiliar names rendered phonetically or transliterated are enclosed in parentheses. Words or names preceded by a question mark and enclosed in parentheses were not clear in the original but have been supplied as appropriate in context. Other unattributed parenthetical notes within the body of an item originate with the source. Times within items are as given by source.

The contents of this publication in no way represent the policies, views or attitudes of the U.S. Government.

PROCUREMENT OF PUBLICATIONS

JPRS publications may be ordered from the National Technical Information Service (NTIS), Springfield, Virginia 22161. In ordering, it is recommended that the JPRS number, title, date and author, if applicable, of publication be cited.

Current JPRS publications are announced in Government Reports Announcements issued semimonthly by the NTIS, and are listed in the Monthly Catalog of U.S. Government Publications issued by the Superintendent of Documents, U.S. Government Printing Office, Washington, D.C. 20402.

Correspondence pertaining to matters other than procurement may be addressed to Joint Publications Research Service, 1000 North Glebe Road, Arlington, Virginia 22201.

Soviet books and journal articles displaying a copyright notice are reproduced and sold by NTIS with permission of the copyright agency of the Soviet Union. Permission for further reproduction must be obtained from copyright owner.

USSR REPORT
CONSTRUCTION AND EQUIPMENT

No. 75

CONTENTS

MACHINE TOOLS AND METALWORKING EQUIPMENT

ROBOTICS

Robotics and Automation: Developments and Application (Various sources; various dates)	1
Robot Capabilities Discussed, by V. Glazkov	
Uzhgorod Introduces Manipulators, by A. Gegal'chin	
Storage for Numerical Program Control, by V.A. Vasil'yev, I.D. Sobolev	
Automatic Manipulators, by V.I. Khar'kov	
Digital Program Control Systems, by A. M. Grivko, et al.	
Gripper Positioning Precision, by Yu. I. Krivchenko, S.V. Gordenko	
Production Complex with Automatic Manipulator, by G.A. Melet'yev, et al.	

ROBOTICS

ROBOTICS AND AUTOMATION: DEVELOPMENTS AND APPLICATION

Robot Capabilities Discussed

Moscow GUDOK in Russian 19 Jan 82 p 4

[Article V. Glazkov, expert, USSR State Committee on Science and Technology: "The Almighty Robot"]

✓ [Text] One of the spheres in which CEMA member countries are collaborating is today associated with the development of industrial robots. These qualitatively new means of automation will, in the view of scientists, be most extensively employed in the enterprises of the future.

Industrial robots have already made their appearance in key machine-building plants.

The industrial robot is a unique mechanical arm which automatically performs production operations in accordance with a program preloaded by an operator. This is why industrial robots are also referred to as automatic manipulators with program control. Operating in combination with machines with numerical program control and other production equipment, the industrial robot will service these machines by performing operations such as position a billet in a machine, removing the finished piece and a number of others.

In conformity with decisions of the 26th CPSU Congress, our country is stepping up its efforts in connection with the introduction of automatic manipulators. Plans call for the development of more than 50 new models of manipulators and 33 machine and equipment systems incorporating them for various branches of the national economy, including machine-building, the mining industry, ferrous and nonferrous metallurgy, agriculture, the light and food industries, construction and transport. The years of the current five-year plan period will see a six-fold increase in the manufacture of automatic manipulators, some 12,000 manipulators to be manufactured in 1985.

Socialist countries are establishing bilateral ties for the development of automatic manipulators. Elaborate programs have been developed for collaboration between, for example, the USSR and the NRB [People's Republic of Bulgaria] and the USSR and the ChSSR [Czechoslovak Socialist Republic] providing for the development, manufacture and introduction of industrial robots.

In 1980 an agreement was signed which provides for multilateral scientific and technical collaboration on the development of advanced designs for industrial robots intended to service metal-cutting machines, forging and pressing and casting equipment. Under

the terms of this agreement, an analysis is being undertaken of the industrial robot designs currently employed in CEMA member countries as well as of their compatibility with a variety of industrial production equipment. On the basis of the results of this analysis it is proposed to develop advanced new series of automatic manipulators with program control.

The coordinated plan of multilateral measures for the period 1981-1985 approved by the 35th session of CEMA establishes a solid basis for collaboration in this area. It provides for joint action on the part of states of the socialist commonwealth in the organization of specialized and cooperative manufacture of automatic manipulators with program control.

Uzhgorod Introduces Manipulators

Moscow EKONOMICHESKAYA GAZETA in Russian No 42, Oct 81 p 16

[Article by A. Gegal'chin, engineer: "Around a Robot"]

[Text] Uzhgorod. Over the years immediately ahead our plant, Uzhgorodpribor, plans to introduce thirteen industrial robots into its production operations. This will be nothing new for us: four automatic manipulators in our electroplating section have already replaced the work of fourteen people. But here's where we have run into some problems.

In borrowing from our neighbors' experience with robotization we encountered the following phenomenon: a series-produced robot efficiently transferred billets from the positioning device to a die, but feeding them to the positioning device was...the lady who had been operating the die. She had previously been able to move them twice as fast, feeding them directly to the die to boot. Then special norms were introduced which are clearly not progressive. Is it possible that these robots are items which were introduced not so much because of the advantages they offered but because of the prestige they would bring? No, the problem lies elsewhere.

The technical literature is now with only rare exceptions looking at questions associated with the development of one's own robots. These will offer potential, however, only as they are equipped with auxiliary devices. These include storage units, feeding, receiving and positioning devices, transporters.... These absorb 40 to 90 per cent of the cost of developing a robotized system, but they are most frequently being designed and fabricated in plants of only modest capacities. So around one of today's advanced robots we see the appearance of labored designs of no great efficiency.

UDC 681.327.4.2

Storage for Numerical Program Control

Moscow MEKHANIZATSIYA I AVTOMATIZATSIYA PROIZVODSTVA in Russian No 7, 1981 (signed to press 24 Jun 81) pp 19-20

[Article by V. A. Vasil'yev and I. D. Sobolev: "Working Storage for ChPU Systems"]

[Text] Machines with ChPU [numerical program control (NPC)] are now being extensively employed in machine-building enterprises, which makes it possible to reduce the labor-intensiveness associated with the working of pieces with close tolerances and complex shapes under series- and small-scale-production conditions.

The operation of equipment with NPC indicates that the efficiency with which it is employed will be a function of not only the timeliness with which the facility is prepared, but also the efficiency and quality with which the control programs are assembled (VII).

The high concentration of operations and the possibility of servicing more than one machine at a time constitute the primary advantages of machines with NPC. They make it possible to employ equipment successfully under large-scale production conditions as well. It is to advantage in this instance to replace the photoreader with punched tape for the program carrier.

To perform their assigned functions series NPC systems incorporate semiconductor memory units. The working storage device (OZU) [WSD] for the mod. H22 and H33 NPC systems, for example, is a separate component consisting of three 140x235-mm wafers. Located on one wafer is the control unit, on the other two the memory unit.

One of the basic problems which has to be solved in the development of a WSD is that of optimum storage capacity. Engineering analysis of pieces worked on program machines with the mod. H22 and H33 linear-circular interpolators has shown that most of them require an information volume of 1.5-1.8 Kbytes.

Analysis of the functional tasks performed by WSD imposes upon them a number of requirements: an information capacity of 2000x8-bit words; a capability for control program input either from punched tape or manually; the possibility of editing a program

from the NPC system operator's console; information storage with system disconnected and low power consumption in "Storage" mode.

The Soviet industry has now begun series manufacture of both individual storage microcircuits and working memory units.

Analysis of series storage microcircuits shows that most efficient from the point of view of economy, reliability and simplicity of fabricating WSD for NPC is the use of the K527RU2 microcircuit, whose advantages consist in the following: simplicity of circuit matching with components of the K155 series and individual leads for feeding the control and memory circuits.

Among the drawbacks to this series is the fact that information is lost when the power is switched off. Pulsed feed to the storage matrix with simultaneous disconnection of the control circuits, however, permits the use of small galvanic components as sources of buffer storage.

Figure 1 is a simplified block diagram of the device, which consists of input 3 and output 5 registers, a memory unit 4, control unit 7, "Write/Read" signal shaper and binary counter 9, crystal selection decoder 10 and oscillator 11.

The WSD provides four modes of operation: "Write," "Read," "Storage" and "Diagnostics."

In the "Write" mode, control unit 7 sends an enabling signal via bus 6 to register 3 and an inhibiting signal via bus 12 to register 5. This permits the operation of input register 3 and blocks output register 5. When information is read from punched tape, signals are supplied from photoreader 1 to the input register 2 of the NPC device and in parallel are written into memory unit 4 via register 3. Upon receipt of synchronizing pulse SI from the NPC device, control unit 7 sends a "Write" signal via shaper 8 and a "Crystal selection" signal via decoder 10 to memory unit 4. Binary address counter 9 is switched at the end of the write cycle. Thus, with the arrival of each synchronizing pulse SI, one more line is written into the memory unit.

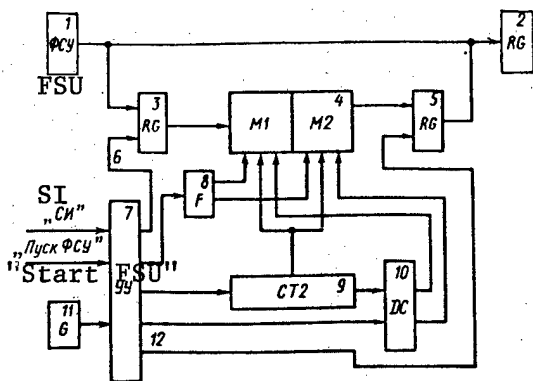

Figure 1. Block diagram of WSD.

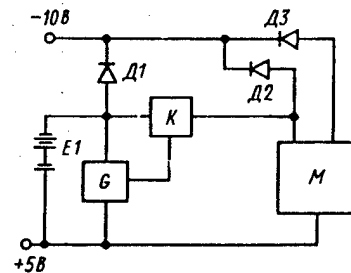

Figure 2. Block diagram of buffer feed unit.

In the "Read" mode, control unit 7 sends an inhibiting signal via bus 6 to register 3 and an enabling signal via bus 12 to

register 5. WSD input is blocked and output enabled. Upon arrival of the command "Start FSU [photoreader]" from the NPC unit and receipt of signals from oscillator 11, control unit 7 sends a "Read" pulse via shaper 8 and a "Crystal selection" signal via decoder 10 to memory unit 4. At the end of the read cycle, binary address counter 9 is switched. Reading continues until the command "Start FSU." This provides sequential output of information from memory unit 4 via register 5 to the input of input register 2 of the NPC unit. Reading rate is determined by the pulse repetition frequency from oscillator 11 and, taking into consideration the dynamic characteristics of the NPC unit, is 1 kHz.

The monitoring circuit of the NPC unit checks the correctness with which information is translated from memory unit 4 (monitoring with reference to module 2 and address structure).

The control program written into memory undergoes editing. This is accomplished by switching the NPC unit to the "Frame search" mode and the WSD to the "Read" mode. When the required frame is found, the NPC unit is switched to the "Manual input" mode and the WSD to the "Write" mode; the required information is then input from the operator's console.

The block diagram of the WSD shown above is simplified. In addition to those already mentioned, the control unit performs a number of other functions insuring the reliability and efficiency of WSD operation: it prevents interscreen intervals from being written into the memory unit from the punched tape, generates an eighth line character and an eighth bit to block the reading of a character (if necessary) during the editing or manual input of a program and generates signals to block "Write" pulses when the system is disconnected.

The control unit also divides memory unit 4 into two subunits M1 and M2. In this instance, access is permitted to only one of the subunits, while the previous program is stored in the other.

In the "Diagnostics" mode, the control unit generates test codes, which are written into memory. With the objective of cutting down on the electronic equipment, the correctness with which the tests are written is determined by the control circuit of the NPC unit (control with reference to module 2). Memory diagnosis requires 3 min. In case of malfunction, the WSD is unplugged from the NPC unit, and the machine operates from punched tape during the time required for repairs.

In addition to questions of reliability, economy and operating efficiency, development of this WSD also involves insuring the possibility that NPC systems under existing production conditions can be rapidly equipped with WSD units.

Series K527RU2 storage matrices do not store information when power is disconnected; the WSD has therefore been provided with a buffer feed from galvanic elements, which provides an alternate source of power to storage matrices in the "Storage" mode.

Figure 2 is a block diagram of the buffer feed unit. Matrix M is supplied from battery E1 when power is disconnected. Initial battery voltage equals the sum of the substrate and storage-matrix supply voltages. Diodes D2 and D3 decouple the power supply circuits of the control circuits and storage matrices in the "Storage" mode. Battery E1 is charged via diode D1 with operation of primary power sources.

Oscillator G and transistor switch K provide a pulsed storage-matrix feed mode. This reduces power consumption more than 15 times. Additional power is supplied in pulses 5 μ s in duration at a frequency of ≥ 10 kHz. Organization of pulsed feed is dictated by the following factors: reduction of power consumption and, consequently, an increase in the time the battery operates without recharging and a reduction in dissipated storage-matrix power with the objective of maintaining the WSD thermal regime, since the NPC frame ventilators providing air cooling are switched off when the circuit is disconnected.

✓ This buffer feed unit incorporates a battery supplying the storage matrices without recharging 200

WSD Specifications

Information capacity, Kbits	16
Memory organization, mm	2048x8 bit words
Operating modes	Write, Read, Storage, Diagnosis
Information input	from punched tape via photoreader, manually from operator console
Program editing	from NPC operator console
Error diagnosis	by control tests
Mode power consumption, V:	
Write, Read, Diagnosis	15
Storage	0.8
Dimensions, mm	65x235x280
Cost (test model), rub.	2000

Equipping NPC units with efficient storage devices reduces the time required to prepare and introduce control programs; reduces machine idle time; increases machine utilization coefficient; reduces product defects; reduces the need for punched tape and punched tape preparation devices and cuts the number of operating personnel required.

The device described here has undergone operational testing in combination with the 16K20F3 machine equipped with a model N22-1M NPC system and demonstrated stability and reliability in operation.

COPYRIGHT: Izdatel'stvo "Mashinostroyeniye", "Mekhanizatsiya i avtomatizatsiya proizvodstva", 1981

Automatic Manipulators

UDC $\Delta 62-229.7.061.4$

Moscow MEKHAIZATSIIYA I AVTOMATIZATSIIYA PROIZVODSTVA in Russian No 6, 1981 (signed to press 21 May 81) pp 11-15

[Article by V. I. Khar'kov, engineer: "Automatic Manipulators"]

[Text] The "Best Models of Automatic Manipulators" interbranch exhibit opened in the machine-building pavilion of the USSR Exhibition of National Economic Achievements in February; it will be open continuously with exhibits periodically updated. The first

exhibition featured some 80 displays, most of them operational. Organizations of 16 ministries and departments participated in the organization of the exhibit. Plans call for this exhibit of the exhibition to be updated this coming August.

What follows is a brief description of some of the displays featured in the exhibit.

NIITraktorsel'khoz mash [Scientific Research Institute of Tractor and Agricultural Machine-Building Technology] has developed its R-505 automatic manipulator (AM) (Figure 1) to service multitool metal-cutting and hydraulic copying machines and machines with NPC [numerical program control] in the machining of tapered shafts. The AM services two machines and a storage unit for billets and finished pieces. The manipulator arm is fitted with two grippers, which cuts down the number of motions required as well as machine work time.

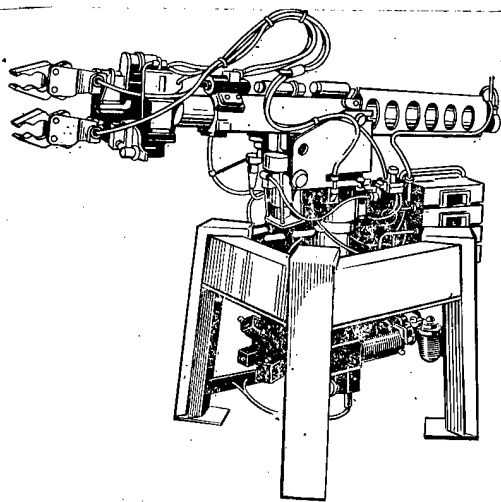

Figure 1. NIITraktorsel'khoz mash's R-505 automatic manipulator.

The 7605 general-purpose automatic manipulator (Figure 2) with PU [program control] is designed to feed and remove pieces worked by pressing, metal-cutting and other processing machines. The manipulator has a cyclical control system. It offers high positioning accuracy and speed of operation.

AM 7605 specifications: number of arms - 2; arm lifting capacity - 2 kg; speed of arm movement : extension - 1000 mm/s (up to 500 mm), rotation - 120 deg/s ($\pm 95^\circ$); elevation - 200 mm/s (150 mm); positioning accuracy ± 1 mm; cycle time - 10 s; dimensions: manipulator - 1710x1710x1036, control system - 480x435x220 mm; weight: manipulator - 240 kg, control system - 20 kg.

The manipulator has a lifting capacity of 10 kg and the following ranges: arm extension - to 600 mm; vertical shoulder movement - to 300 mm. Shoulder rotation with intermediate point - 0-90-180°; gripper rotation - 180°. Positioning accuracy in extreme positions - 0.2 mm, in intermediate position - 2 mm.

The dimensions of the machine are 700x1250x1530 mm; it weighs 500 kg. Cost - 15,000 rubles.

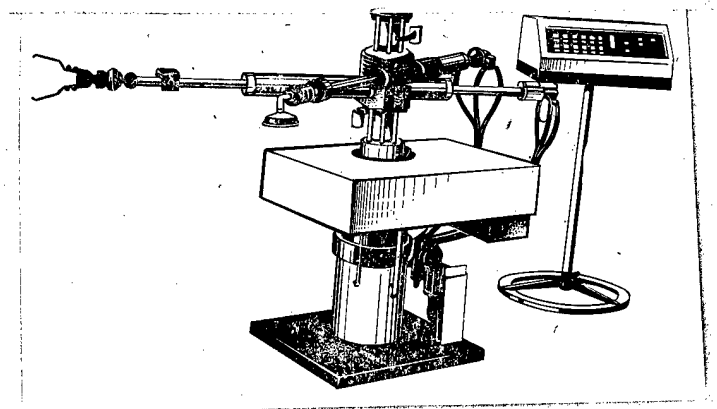

Figure 2. 7605 automatic manipulator.

Introduction of the AM 7605 will yield an annual economic gain of some 2000 rubles.

The Tiraspol' Casting Machine Plant im. S. M. Kirov has built the mod. A711A07 automated pressure casting machine (Figure 3) which functions with an AM for the metal-pouring process.

The manipulator pours the metal (aluminum alloy) with a measuring ladle; metal weight - 2.1 kg.

The MAK-2-320 automatic conveyor manipulator (Figure 4) developed by VNIPTmash [All-Union Scientific Research, Planning and Design Institute of Hoisting and Conveying Machinery and Loading-Unloading and Warehouse Equipment and Containers] has been designed to load (unload) overhead load-transporting conveyors. The manipulator hangs a suspended load on a conveyor load carriage hook while the conveyor continues in motion. The machine can handle loads weighing up to 320 kg. The MAK-2 manipulator can be employed in machine, assembling, foundry, heat-treatment, electroplating and painting shops. The manipulator arm is 1200 mm long and has a positioning accuracy of ± 3 mm.

The annual economic effect to be achieved with introduction of this AM runs to 12,000 rubles.

The manufacturer is the Konveyer production association (L'vov). (See the article by V. G. Konobalov, "Automatic Hoisting and Conveying Manipulators," MEKHANIZATSIYA I AVTOMATIZATSIYA PROIZVODSTVA, 1980, No. 8.)

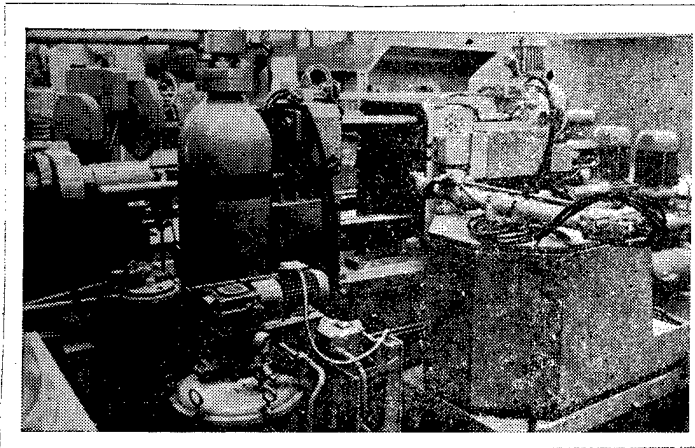

Figure 3. Mod. A711A07 pressure casting machine with AM of the Tiraspol' Casting Machine Works imeni S. M. Kirov.

The LAST-1 (Figure 5) automatic line for assembling small transformers with glueing, drying and active control of electrical and geometric parameters consists of the following: assembling, test

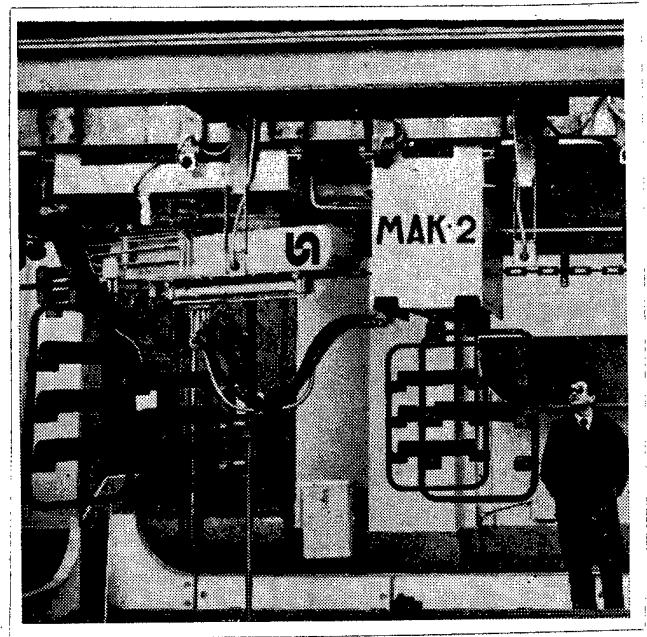

Figure 4. VNIPTmash's MAK-2-320 automatic conveyor manipulator.

and finishing table, AM for assembling coils with the lower core pair, AM for assembling coils and glueing with upper coil pair; a unit for forming and drying the transformers and a conveyor to feed the coils into the working range of the AM and an electronic control console.

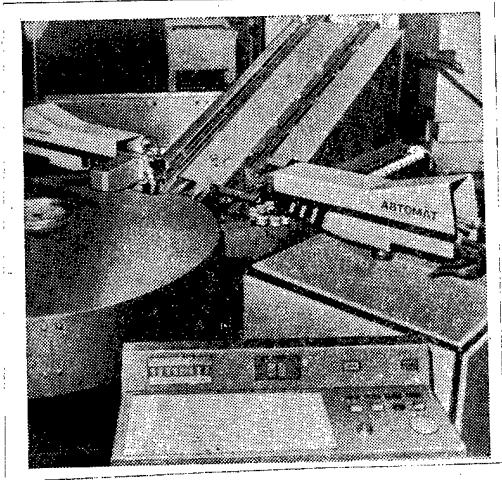

Figure 5. LAST-1 automatic line with AM.

Introduction of this line has freed up 24 persons.

The Moscow Machine-Tool Manufacturing Plant imeni S. Ordzhonikidze has built the LAS ChPU 13 rapidly readjustable automatic line for machining shafts in both small-scale and series production. The line rough- and final-finishes cylindrical, conical and irregularly shaped surfaces, channels and bevels, cuts grooves and threads etc. The automatic line, which consists of semiautomatic lathes with NPC, is serviced by the SM160F2 gantry automatic manipulator (Figure 6).

The manipulator will load machines in any sequence in accordance with a given program. The AM program is determined through teaching with the aid of working memory. Permanent storage is on magnetic tape.

Use of this AL [automatic line] reduces the number of personnel required and permits the introduction of multimachine servicing.

LAC ChPU 13 AL specifications: billet diameter (max.) - 400 mm; piece length (max/min) - 1400/500 mm; line dimensions (proposed) - 3500x6980 mm.

LAST-1 Line Specifications

Number of AM	2
Maximum manipulator arm motion, mm:	
vertically	185
horizontally	300
Maximum angle of manipulator arm rotation around vertical axis, deg	240
Manipulator lifting capacity, kg	0.5
Number of degrees of motion	3
Positioning accuracy, mm	±0.15
Type of manipulator and line machine drive	pneumatic
Control system	adaptive with computer-control capability.
Program medium	printed-circuit board
Number of executable commands ..	40
Number of correctable programs ..	6
Number of sensors:	
for external information	13
for internal information	28
Line weight, kg	800
Line dimensions, mm	2200x2152x1140

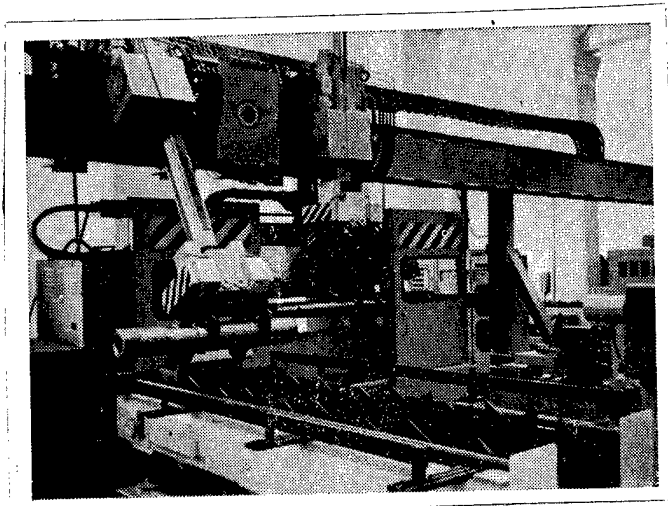

Figure 6. LAS ChPU 13 automatic line with AM, Moscow Machine-Tool Manufacturing Works imeni S. Ordzhonikidze.

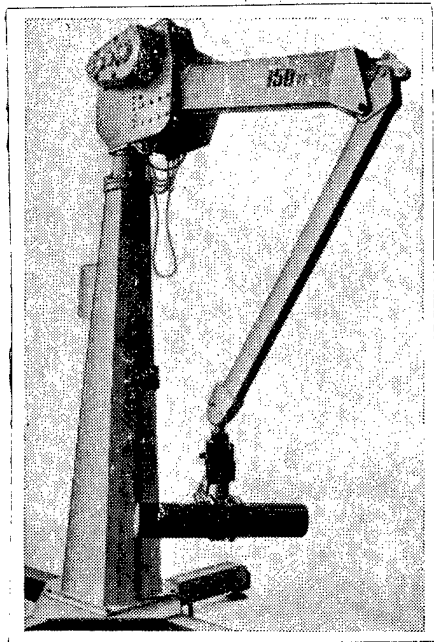

Figure 7. ShBM-150 swivel-balance manipulator.

The ShBM-150 swivel-balance manipulator (Figure 7) is designed to hoist and convey loads weighing up to 150 kg in loading lathes, presses and other production equipment as well as for transport operations and to service conveyors.

ShBM-150 Manipulator Specifications

Lifting capacity, kg	150
Hoisting and lowering speed, m/s:		
maximum	0.5
minimum	0.005
Arm radius, mm:		
maximum	3000
minimum	600
Load hoisting height, mm	.. to	1750
Regulation of load lifting and lowering height	continuous
Manipulator rotation around axis of supporting and rotating unit, deg	360
Rotation of gripper tip around its axis	unlimited
Power consumption, kW	2

The manipulator may be fitted with interchangeable mechanical, vacuum and electromagnetic load-gripping attachments.

The manipulator has acoustic and illuminated overload warning systems, a power-on indicator and an emergency stop button on the arm near the control lever. When the stop button is pushed, the load stops at its height as of the moment the signal is given.

The manipulator's electronic control system has been awarded the state Seal of Quality.

The "automatic manipulator-lathe" production system (Figure 8) is designed to turn smooth and tapered shafts in an automatic mode. The system consists of a mod. 16K20F3 lathe, a mod. SN3308.01 double-arm automatic manipulator mounted on the headstock and

a storage and feeder unit. The system can machine shafts 20-125 mm in diameter, 160-750 mm long and weighing up to 40 kg; speed of manipulator carriage movement - 200 mm/s; positioning accuracy - ± 1.5 mm; maximum billet change time - 12 s; dimensions - 6230x3760x2460 mm; weight - 5800 kg.

This production system was introduced at Novosibirsk's Siblitmash works in 1979.

Introduction of the system has freed two workers; it has made it possible for a single worker to service five machines and increased labor productivity 30 percent. The annual economic gain derived from introduction of the system has run to 5300 rubles.

The system was developed by the NPO [scientific-production association] Orgstankinprom and its Novosibirsk branch and built by the Orgstankinprom Institute's Dmitrovskiy experimental machine plant.

The "Machine-AM" lathe system (Figure 9) is designed to machine pieces in the body-of-rotation category (disks, wheels). The system consists of a semiautomatic chucking lathe with NPC and a mod. SM80Ts2501A lathe AN.

This semiautomatic machine is designed to turn pieces made of ferrous and nonferrous metals and alloys having cylindrical, tapered and curvilinear surfaces in accordance with an assigned program in small-scale production. Tools are changed automatically. Turnings are removed by conveyor.

The AM is designed to load and unload the machine.

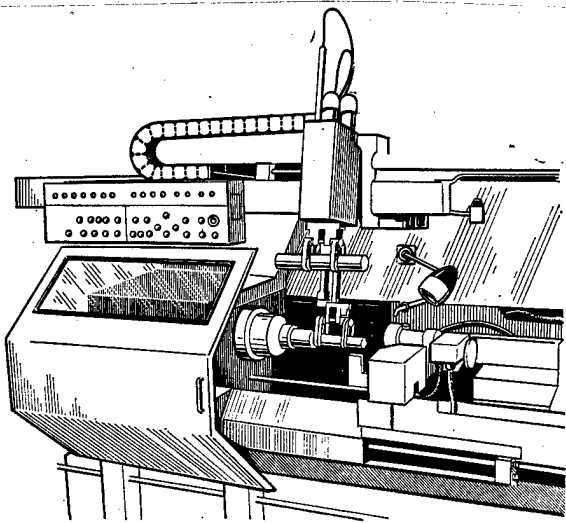

Figure 8. NPO Orgstankinprom's "Machine-AM" system

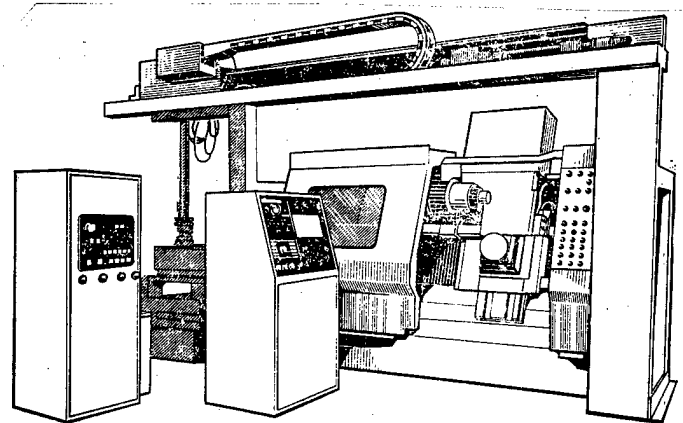

Figure 9. Ryazan' Special Machine-Tool Design Bureau's "Machine-AM" system

The manipulator consists of a gantry with a single overhead rail, along which travels a

carriage with an extendable arm with a rotatable two-place gripper, a time-step table with a removable container having a capacity of up to 32 billets mounted on it, a self-contained hydraulic unit and a cyclical control system.

The AM performs the following operations: removes finished piece and fits new billet into chuck, transfers finished piece to container and places it in proper compartment. The manipulator is equipped with elements providing it the capability of adapting to object geometry and orientation, which eliminates the necessity of preparing control programs and permits rapid adjustment for different object type sizes.

The AM's gantry configuration requires only a small amount of floor space and provides free access to the working area of the machine.

The design of the gripper, the arrangement of container packing compartments and the method of manipulation make it possible to pack pieces closely and compactly in the container with respect to both diameter and width.

The design of the time step table and the container makes it possible to employ this AM in an automated machine section with automatic storage.

The mod. US-3A pneumatic cyclical manipulator control system was developed on the basis of Volga jet components.

The manipulator's equipment with changeable grippers and container packing-compartment components makes it possible to load pieces of varying configurations within a given range of weights and dimensions.

Employment of this system increases machining efficiency through intensification of cutting regimes and reduction of loading time, cuts the number of workers required through multimachine servicing and improves organization of production operations.

Use of the system yields an economic gain of 23,000 rubles.

Basic System Specifications

Utilization coefficient	0.9
Electric motor power, kW	42
Dimensions, mm	5600x4650x3250
Weight, kg	14,500

AM Specifications

Maximum load capacity, kg	80 (two 40-kg pieces)
Object diameter, mm	250-400
Object width, mm	125-250
Range of arm movement, mm:	
horizontally	10-140
vertically	3370
Maximum travel of time step table, mm	1000
Angle of gripper rotation, deg	680

Speed of arm movement, mm/s:	
horizontally	800
vertically	500
Rate of gripper rotation, deg/s	90
Positioning accuracy, mm	±0.3
Machine loading time, s	25
Number of rows of pieces to be packed in container	2; 3; 4
Number of pieces per row	3; 4; 6; 8
Power consumption, kW	5
Plane container dimensions, mm	600x800
Manipulator dimensions (without gantry), mm	950x700x2400
Manipulator weight (without gantry), kg	420

The Ryazan' Special Machine-Tool Design Bureau developed this system. It was built by the Ryazan' Machine-Tool Manufacturing Production Association. The Volga branch of the VNIASH [All-Union Scientific Research Institute of Abrasives and Grinding] developed and built the control system.

Automated electroplating sections incorporate the following standardized components: AM, baths, metal structural components, drying chamber, drums, signalling device etc. The number of units will be determined by the productivity required, the type and thickness of coating and the nature of the technical process. Pieces to be electroplated are hung on a suspending arm or loaded loosely in drums and conveyed to their proper processing points in accordance with the desired program.

AM automatically performing the following operations are employed as the transport unit: grip suspension device or drum, hoist, hold position for solutions to drain, move to next position, stop, lower, release drum or suspension device, move to next position. The manipulator is controlled by a signalling device incorporating noncontact logical elements.

Basic section data: maximum productivity in coating applications: galvanic - 120 m²/h, chemical - 150 m²/h; lifting capacity - 500 kg; rate of horizontal AM motion - 17 m/min; load hoisting and lowering rate - 8 m/min; drum payload during coating process: galvanic - 60 kg, chemical - 120 kg; section dimensions - 12-32x2.5-6x3-5.5 m; weight - 10-40 t.

The developer is the Tambov Electroplating Equipment Works' central electroplating equipment design bureau.

The Tambov Electroplating Equipment Works built the system!

The AM-based system shown in Figure 10 designed to apply protective and decorative powder coatings to objects having the dimensions 1000x250x350 mm in mass production consists of two manipulators 1 equipped with four RPU-1V electrostatic sprayers; a continuous spray chamber 5 with two dispensers 2, each of which is designed to be connected to two of the sprayers; powder traps 4 and a control panel 3.

Two electrostatic sprayers are mounted on an arm fastened to the AM carriage. The carriage travels up and down along a guide inside the column; speed is regulated continuously.

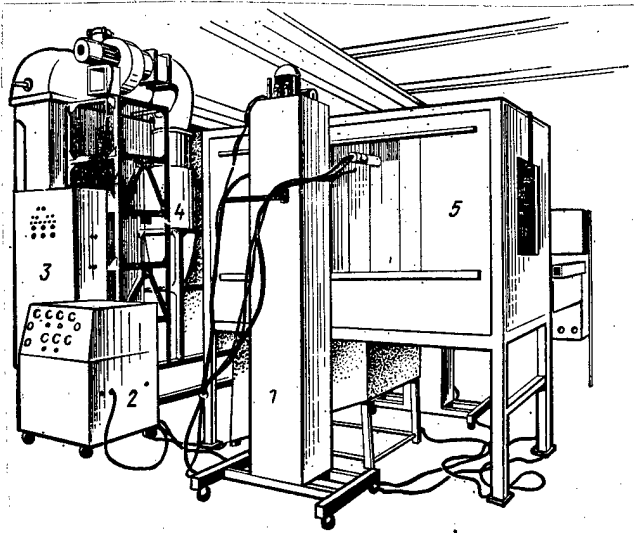

Figure 10. NPO VPKTIstroydormash's AM-based system for applying powder coatings.

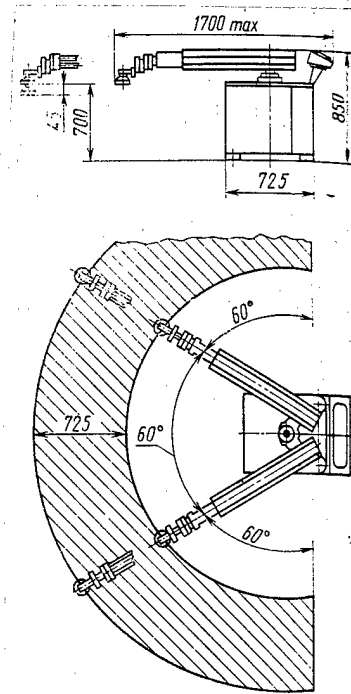

Figure 12. Working areas of the Altay Scientific Mechanical Engineering Research Institute's RPG-1M AM

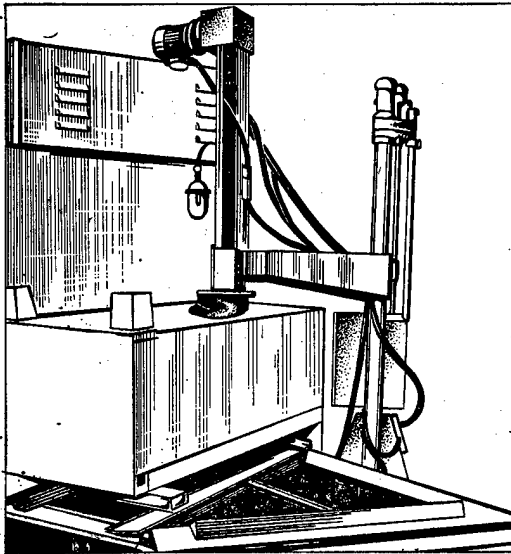

Figure 11. NPO VPKTIstroydormash's AM for painting interior surfaces.

The continuous spray chamber has two 400x500 mm transport accesses and two working accesses located on both sides. The chamber is equipped with two dispensers.

Powder is trapped by a two-stage filter consisting of a cyclone and a bag filter to remove powder paint waste from the spray chamber and trap powder in the exhaust air. Employment of this device permits 98 per cent utilization of powder paint and increases the economy of the painting process.

System specifications: operating capacity - 60 m²/h; voltage across corona electrode - 30-35 kV; rated current in charging device - 50 μA; manipulator carriage travel - 400-700 mm; volume of air removed from spray chamber - 2000 m³/h; system weight - approximately 2500 kg.

Introduction of this system automates the painting process, increases labor productivity 1.5-2-fold, improves product finish quality and sanitates working conditions, reduces powder paint loss and prevents pollution of the atmosphere.

The economic gain derived from introduction of the system in branch works runs to 100,000 rubles.

The NPO VPKTIstroydormash [All-Union Planning, Design and Technological Institute of Construction and Road-Building Machinery] developed the system. It was fabricated by NPO VPKTIstroydormash's Artsizskiy experimental test plant.

The system has been introduced at Daugavpils' Elektroinstrument works.

The automatic manipulator shown in Figure 11 designed to paint the interior surfaces of round tanks and square tanks up to 1200x1200 mm in cross-sectional area and 2.5 m long consists of a column mounted on a special base along which travels a screw-guided arm; a paint sprayer is attached to the end of the arm.

The paint sprayer is turned on and off by signals from terminal switches. It rotates simultaneously around its horizontal axis (the axis of its shaft) and around an axis perpendicular to that of the shaft. The control console is located in the lower part of the column; at the base of the column are mounted two paint-heat tanks for the paint and its vehicle. Tanks to be painted are fed to the AM by rail-mounted truck or other hoisting and conveying equipment.

The tank-painting process proceeds as follows. A tank to be painted is mounted on a carousel, moved to the painting position and secured. When the "Operate. Start" button is pushed, the arm lowers the painting device into the tank. When the arm stops in its low position the paint sprayer is switched on. The line drive is activated following an interval of 5-20 s as set by time relay. Painting continues while the sprayer is in motion.

When the sprayer reaches its extreme position the line stops; following an interval of 5-20 s reverse drive is activated. When the sprayer returns to its initial position the process is repeated. Upon completion of its second pass the sprayer is switched off and the arm raised; the manipulator's operating cycle is completed when the arm reaches its upper position. The painted tank is removed and the next positioned for processing.

Employment of this AM frees two workers, liberates workers from manual labor, increases labor productivity and improves coating quality.

The automatic manipulator has been introduced and is now in effective operation at the Prilukskiy fire-fighting equipment plant.

The annual economic gain derived from introduction of the manipulator amounts to 15,000 rubles.

The NPO VPKTIstroydormash developed and fabricated the system.

The RPG-1M double-arm automatic manipulator (Figure 12) is designed to automate cold extrusion operations on open or closed crank presses with forces up to 160 ton-force using individual billets.

The manipulator is capable of the following movements: independent longitudinal arm movement forward and backward; simultaneous arm rotation relative to vertical axis; vertical movement of the grippers mounted on each arm. The AM has manual drive for vertical movement of the adjustment arms to the level of the die.

It is equipped with an electromagnetic or vacuum gripper depending upon the configuration of the billets to be handled.

Manipulator drive is pneumatic from a 4-6 kg/cm²-pressure system.

The control system is cyclical and based upon integrated microcircuits; it provides 19 programs for simultaneous manipulator-press operation. The operational program is determined through commutation of two output fields of the working-device position sensors, the timer and the servo mechanisms.

The manipulator is equipped with a special cartridge device providing automatic operation of the Press-manipulator system.

AM Specifications

Overall payload capacity, kg	10
Payload capacity per hand, kg	5
Coordinate system	cylindrical
Number of degrees of movement	4
number of those programmable	3
Horizontal arm movement:		
distance, mm	725
rate, mm/s	750
Vertical arm movement (nonprogrammable), mm	150
Vertical gripper movement, mm	45
Arm rotation relative to vertical axis, deg	120
Positioning error, mm:		
with respect to arm rotation	±0.5
with respect to other coordinates	±0.1
Maximum billet size, mm	500x500
Overall dimensions, mm	1650x570x x850
Weight, kg	600

The Altay Scientific Research Institute of Mechanical Engineering (ANITIM) developed the system.

COPYRIGHT: Izdatel'stvo "Mashinostroyeniye", "Mekhanizatsiya i avtomatizatsiya proizvodstva", 1981

Digital Program Control Systems

UDC 621:771:23:681:32

Moscow MEKHAZIZATSIYA I AVTOMATIZATSIYA PROIZVODSTVA in Russian No 9, 1981 (signed to press 27 Aug 81) pp 11-13

[Article by A. M. Grivko, Candidate of Technical Sciences and S. V. Zhukov and V. P. Silenko, engineers: "Digital Program Control of Plate Mill Screwdown Mechanisms"]

[Text] Practical experience with the development and operation of digital program control systems (DPCS) demonstrates that program control is most effective in the case

of stationary production processes. Any departure from these conditions requires changeover to a new subroutine and occasionally to manual control of the rolling process. Further development of these systems involves expanding their functional capabilities and improving their logic and programs as well as their ability to adapt to the changing conditions of the production process.

This article looks at problems involved in developing the logic and programs of DPCS for electromechanical screwdown mechanisms (NM) [SM] on reversible plate mills (TLS) [PM] and results achieved from their application in industry.

Existing PM for the most part remain unequipped with up-to-date systems permitting regulation of plate thickness during the rolling process. Affecting longitudinal differences in strip thickness (Δh) in a run are stand design, strip characteristics, degree of reduction, precision of roll gap setting (ΔS) and metal reduction per pass:

$$\Delta S = \Delta h \left(1 + \frac{M_n}{M_k} \right), \quad (1)$$

where M_k, M_n - the modulus of rigidity of the stand and the strip respectively.

Maximum roll-setting error for breakdown rolls ranges from ± 0.5 to ± 0.1 mm at process rates of 80-40 mm/s and from ± 0.15 to ± 0.05 mm at a rate of 25-10 mm/s for finishing rolls.

NM TLS [plate mill screwdown mechanisms (PMSM)] are governed by a cyclical law. The motion of the top roll of a stand has the same values on each pass of a given run of plate. In this instance reduction decreases with each successive pass.

Plate-rolling control depends upon many factors and includes the following: rolling with maximum reductions with respect to rolling motor torque or force exerted on rollers; constancy of reductions or forces at individual stages of the rolling process; rolling slabs transversely or longitudinally; breakdown with respect to width or length; rolling at fixed temperatures in finishing passes etc.

Plate is rolled with "roller undercut" operations or without any change in inter-roll gap ("smoothing pass") to achieve the desired planeness with fixed values of transverse variations in thickness.

"Head-on" metal rolling, that is, rolling with a negative or zero inter-roll gap setting is a special characteristic of the process of rolling plate with thicknesses not exceeding the extent of stand deformation

$$h \leq \frac{P}{M_k}, \quad (2)$$

(where h - plate thickness; P - pressure of the metal on the rolls). Play in the operating linkage between the electric motor and the rolls as the latter grip the metal can bend the strip too much in the vertical plane because of frictional contact between the working rolls and the development of play in the operating linkage of one of them. To prevent the strip from being bent from below, operators employ a method which breaks the frictional contact between the working rolls. In this instance, before the slab is fed into the stand they raise the top roll and then set the rolls in the desired position as the latter grip the metal.

Manual control with this rolling process is difficult.

On the basis of the production operations we have mentioned and the operating conditions of the screwdown mechanisms, automatic digital program control systems must perform the following functions: measure parameters of the rolling process; identify operational conditions and production operations and generate initiating signals; write and store reduction programs; provide for manual or automatic correction of a reduction program to be executed taking into account the most important perturbation effects upon the process; determine controls, specifically by moving rolls for each pass or individual step in the rolling process; generate specific instructions for changes to be made by the system servo component; provide automatic movement of the top roll with the required precision; monitor realization of prescribed reduction conditions and protect mechanical and electrical equipment in emergency situations.

Figure 1 is a block diagram of the system. The DPCS is linked to conventional systems for manually controlling the electric SM drive (EPNM) [ESMD] via commutator K and consists of a logic and program control unit (BLPU) [LPCU], an internal memory unit (OZU) [IMU], a digital position regulator TsPR [DPR] and processing information sensors (DTI) [PIS], which comprise a photo relay (F) and sensors measuring rolling forces (P), plate thickness (h) and inter-roll gap (DP).

The operator teaches the DPCS in the manual mode. He generates instructions (U_{zr}) to alter the gap between rolls (S_z) using master switch (KK) via commutator (K) to the ESMD, which has sensors monitoring speed (DS) and DP.

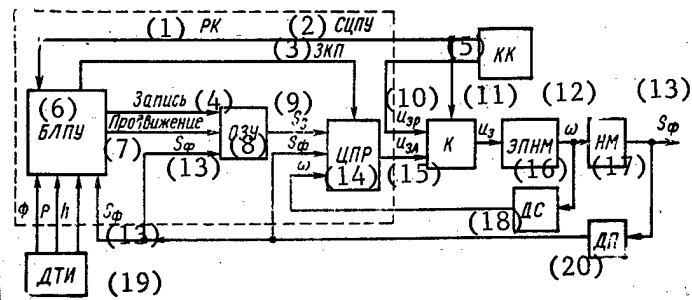

Figure 1. Block diagram of digital program screwdown control. 1 - RK; 2 - DPCS; 3 - ZKP; 4 - write; 5 - KK; 6 - LPCU; 7 - feed; 8 - IMU; 9 - S_z ; 10 - Ts_{zr} ; 11 - Ts_z ; 12 - ω ; 13 - S_F ; 14 - DPR; 15 - Ts_{zA} ; 16 - ESMD; 17 - SM; 18 - DS; 19 - DTI.

triggers S_z in accordance with the optimum law on the basis of information on S_F and speed of roll motion (ω).

Input information from the PIS to the LPCU identifies the production operational situations "metal gripped by rolls" (MV), "end of rolling cycle" (KTs) and "roll undercut" (F_{pv}) and operator functions "manual correction of metal reduction" (RK) and system "readiness" for program-mode operation. Situation identification in the LPCU generates control signals to "write" actual inter-roll gap (S_F)

values into internal memory and "feed" a line to the IMU, in accordance with which files of operational information on the plate rolling cycle are recorded in memory. When the system is switched to the automatic control mode, instruction U_{za} is transmitted to the ESMD from the DPR, which is a circuit external to the SM and

The IMU instructs the DPR to change the inter-roll gap upon receiving a "feed" signal and to close the position circuit after receiving a ZKP signal, which is generated in the LPCU.

When the plate rolling process has been completed the LPCU generates the command KT_s, at which the SM returns to its initial position, and the rolling cycle is repeated.

The system permits manual correction of the reduction program, which makes it possible for the operator on any pass to change the value of S_z written into the IMU to take into account changing situations or the appearance of perturbations. Adaptation functions may also be input into the LPCU.

Identification algorithms for PM employ a priori and current information on the position of the slab relative to the rolls of the rolling mill, the operation of the machinery in the section of stands, the order in which they are switched on and off, the speed, acceleration and loads on the machines etc. A priori information is generated by models of the rolling process. The type of identification algorithm depends upon stand and machine design, the existence of information sensors as well as the nature of any interference affecting sensors and communication channels.

Below we will be looking at identification of the command "roll undercut" (F_{pv}).

Figure 2 shows diagrams of the motion (S) (see Figure 2a), speed (ω) (see Figure 2b) and acceleration of roll motion ($d\omega/dt$) (see Figure 2d) during ESMD operation. Also shown is the change in master switch instruction signal (i_{kk}) (see Figure 2c). The initial (S_n), upper (S_v) and final (S_k) roll positions are recorded in the "write" mode. S_n and S_k are written into internal memory at the command MV, S_v at the command F_{pv} (see Figure 2e), which is generated in accordance with the logical condition

$$F_{pv} = F_{\omega} \wedge F_y \wedge F_k. \quad (3)$$

The situation identification algorithm for adjusting SM speed through zero reduces to verification of the condition

$$F_{\omega} = 1 \text{ when } \omega^* < \omega < 0;$$

$$F_{\omega} = 0 \text{ when } \omega^* > \omega > 0.$$

Negative drive acceleration situations and the position of the master switch in the "reverse" position (KKN) are recorded for identification of signals $F_y = 1$ and $F_k = 1$. Figure 2e shows the hardware required to execute the proposed algorithm (3).

The Kiev Institute of Automation has officially approved the DPCS hardware and software under actual industrial conditions.

Figure 3 shows the combined algorithm for controlling plate mill screwdown mechanisms. It comprises a reduction-mode record unit, a unit to recover the address of file S_z and a unit for transmitting S_{zi} instructions for setting the roll gap in the next pass.

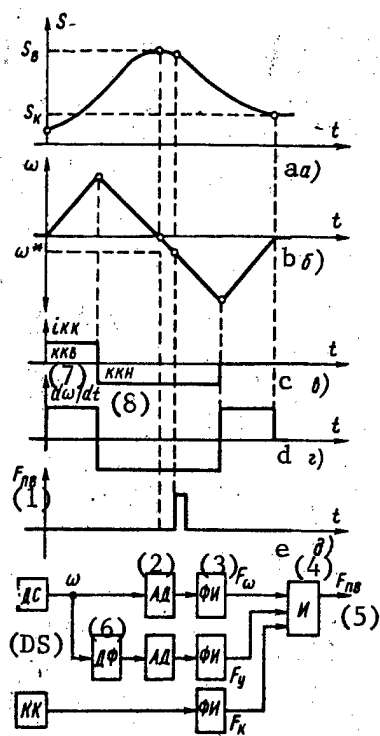

Figure 2. Generation of "roll undercut" command. 1 - F_{pv} ; 2 - AD (amplitude discriminator); 3 - FI (pulse shaper); 4 - I (conjunctive [AND]); 5 - F_{pv} ; 6 - DF (differentiator); 7 - KKV (master switch position "up"; 8 - KKN (master switch position "down."

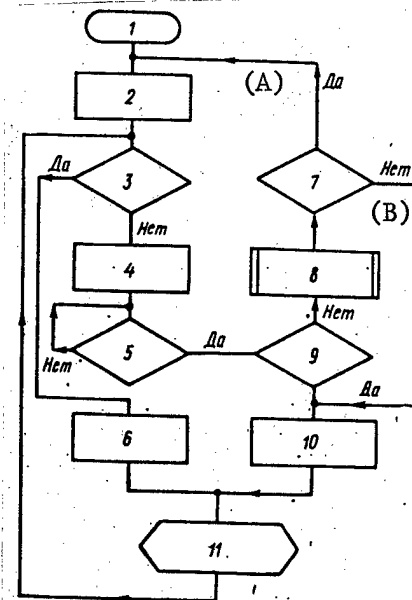

Figure 3. Block diagram of screw-down mechanism control algorithm. A - YES; B - NO; 1 - initialization; 2 - write reduction mode; 3 - $S_{zi} < 0$; 4 - output of next S_{zi} instruction; 5 - MV?; 6 - roll undercut; 7 - IRO?; 8 - recover \bar{S}_z file address; 9 - $|S_{rei} - S_{zi}| \leq \epsilon$; 10 - record operator intervention; 11 - readdress file S_z .

Operation of the algorithm consists in the following.

The system is taught, that is, a record made of the mode of reductions, during the process of rolling the first plate in a run. The operator selects the method of reduction directly on the basis of production instructions, his individual capabilities, the condition of his equipment, the wear of the working and backup rolls, the assortment to be rolled and other criteria. The control method employed remains unchanged for the entire period during which the metal of a particular run is being rolled.

The inter-roll gap assigned for each pass is written into the memory of the \bar{S}_z instruction file. After S_{vi} is recorded for the appropriate pass, task S_{ni+1} is entered in the same file (with a minus sign) to undercut (podryv) the top roll:

$$S_{ni+1} = -(S_n - S_{rei}), \quad (4)$$

where S_n - upper roll position prior to (i+1)-th pass and S_{rei} - actual roll gap on the i-th pass.

Automatic programmed control of the rolling process begins with the second plate of the run. Following output of the next instruction and after the rolls grip the metal in each pass a check is made of the correspondence between the actual gap between the rolls and task S_{zi} in accordance with the equation

$$|S_{rei} - S_{zi}| \leq \epsilon_i. \quad (5)$$

Tolerance ϵ_i is determined by the statistical characteristics of the system. If condition (5) is not satisfied, this indicates either a malfunction in the DPCS or a change in reduction mode by the operator. In the first instance, the algorithm provides for recovery of the address of file \bar{S}_z ; in the second case, a mode-reduction change

identifier (IRO) is generated, and the system proceeds to write the new rolling program. If the operator is responsible for any deviation in ϵ_i (RK, see Figure 1) file \bar{S}_z is corrected (see Figure 3-10).

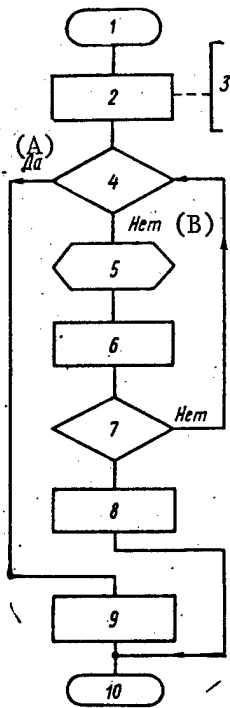

Figure 4. Block diagram of algorithm for recovering task file address: A - YES; B - NO; 1 - initialization; 2 - preparation; 3 - recovery of \bar{S}_z address, counter i (i: = n); 4 - $|S_{rei} - S_{zi}| \leq \epsilon_i$?; 5 - readdress file S_z ; 6 - decrease i: i-1; 7 - i = 0; 8 - IRO: =1; 9 - IRO: =0; 10 - output.

A block diagram of the algorithm for file address recovery is shown in Figure 4. The algorithm provides for retrieval of task S_{zi} from file \bar{S}_z , whose confidence interval will include the value of the actual inter-roll gap of the current pass, and recovery of task S_{zi} and its address in the file according to counter number i.

DPCS programs expand monitoring and guard functions, self-adjustment of position regulator and exchanges of information between the operator and higher-level ASU TP [automated process-control systems].

DPCS systems would advantageously monitor permissible parameter values

$$\begin{aligned} S_{z \min} &\leq S_z \leq S_{z \max}; \\ S_{F \min} &\leq S_F \leq S_{F \max}; \end{aligned} \quad (6)$$

monitor the degree of permissible change in instruction relative to the value for the preceding pass, that is,

monitor with reference to permissible roll movement on $i+1$ -th pass

$$S_{zi} - S_{z(i+1)} \leq \Delta S_{\text{perm}}; \quad (7)$$

monitor prescribed movement taking into account the possibility of overregulation and incomplete processing:

$$S_z - S_F \leq \epsilon; \quad (8)$$

monitor the functioning of position (speed) sensors, sensors monitoring continuity of the change in S_F , for example;

monitor the mechanical and electrical connection between the position (speed) sensors and the mechanism, with reference, for example, to maximum permissible change in S_F when $\omega_F \neq 0$ and

monitor degree of reduction with respect to allowable metal pressure on the rolls and rolling moment.

Allowable quantization time, equal to the duration of all operations in the system, can be the only limitation upon increasing and adding to the system's monitoring functions. DPCS operations are performed cyclically, that is, at a constant frequency independent of the state of the object. Cycle time T_{ts} is a function of the number of tasks in the system to be performed and is computed by the expression

$$T_{ts} = \Sigma T_i + \Sigma T_r + \Sigma T_y + \Sigma T_k, \quad (9)$$

where T_i - time required to interrogate sensors for process information and to analyze it; T_r - time required to compute control responses; T_k - time required to compute corrections or perform adaptation functions; T_y - time required for operation of control responses; T_z - time required to perform system monitoring and protective functions.

Primary computation operations (9) are performed immediately before the metal is ejected by the rolls of a stand and during the time required for the SM electric drive to execute the required movements; for most PM this is 0.5-1.0 s.

Results of industrial operation of a DPCS with the PM 2250 on breakdown and finishing stands have shown that program control reduces the time required to execute prescribed movements by 1.7-2 s; this increases final rolling temperature by 10-20°C and increases the productivity of a section of stands for some products up to 3-5 per cent; optimizes the operation of stand components by reducing the number of times the ESMD is activated, regulating electric drive activation lead before the metal is ejected from the rolls and reducing electric energy losses and stabilizes the rolling process through more precise settings of inter-roll gaps (± 0.3 mm for two-high, ± 0.1 mm for four-high mills) for each pass and narrowing the range of variation in slab thickness.

Analysis of PM orders indicates that program control makes it possible to roll more than 80 per cent of the volume of metal.

Expansion of the functional and computational capabilities of systems with programmed execution of control algorithms enhances the efficiency and reliability with which they function.

COPYRIGHT: Izdatel'stvo "Mashinostroyeniye", "Mekhanizatsiya i avtomatizatsiya proizvodstva", 1981

Gripper Positioning Precision

UDC $\Delta 621-229.7:\Delta 62-539$

Moscow MEKHANIZATSIYA I AVTOMATIZATSIYA PROIZVODSTVA in Russian No 10, 1981 (signed to press 23 Sep 81 pp 14-16)

[Article by Yu. I. Krivchenko, Candidate of Technical Sciences, and S. V. Gordenko, engineer: "Optimizing the Positioning Precision of Automatic Manipulator Grippers"]

[Text] One way to solve the problem of "nonhuman" technology in machine building is to develop fundamentally new manufacturing processes based upon the use of automatic manipulators. Those involved in designing and introducing into production operations cannot be guided by traditional methods of machine-tool fabrication alone or approach them from the point of view of conventional automation. Solidly based selection of such AM parameters and characteristics as lifting capacity, operating speed, type of drive, dimensions of working area, number of degrees of motion, positioning precision [repeatability] etc. constitute indispensable conditions governing proper planning and design of production sections.

The positioning precision of the gripper or other working component is one of the characteristics determining the possibility of AM application. With advances in the field of AM development and the extensive introduction of these devices into production operations, as well as with the accumulation of experience in the development and operation of these devices have come increasing requirements for positioning precision, and for a number of types of AM, assembly AM for example, this has become the decisive parameter. The development of high-precision manipulators without degrading other parameters--lifting capacity, distance of working motion of servo mechanisms etc.--has in this connection become of great importance.

A traditional method of increasing AM positioning precision is to modify their technical specifications. This requires high precision and quality in the fabrication of components and the assembly of units, which entails additional expenditures and cannot always be achieved; the availability of complex damping devices insuring smoothness in the motion, acceleration and deceleration of servo mechanisms; constant pressure and temperature of the energy carrier in pneumatic and hydraulic drive systems and, consequently, the availability of devices insuring this constancy (reduction valves, systems for cooling the working fluid etc.) and great rigidity in the working components, which entails increases in manipulator mass, and the rigidity required for manipulators of high lifting capacity may be technically unattainable.

These factors complicate machine design, reduce reliability and shorten service life. Then we see increased expenditures for maintaining, servicing and repairing AM already in operation. Excessively high precision in the manufacturing process increases production costs without improving the functional quality of the components. There is thus a limit to increases in positioning precision to be achieved by the traditional method, beyond which the development of higher-precision AM becomes economically disadvantageous.

The method of increasing positioning precision to be described here is based upon the introduction into an AM control system of loops to correct motion with respect to each of the coordinates, which have been synthesized by means of analytical design.

The term "analytical design" is to be understood in this instance to refer to methods of control-system synthesis making it possible analytically to determine the structure and parameters of a control system which would be optimum in the sense of the minimum of a given functional with given object controls and limitations. Input control signals for the system may be generated on the basis of observations of certain variables which describe the system and a control strategy based upon a priori information about system characteristics and the past history of changes in input and output variables. System behavior may be regulated by input control signals generated by any method given the achievement of the desired objective and the realization of limitations upon system control and state variables.

So with given limitations an objective may be achieved by employing a number of control strategies. It will therefore be natural to select from among all those permissible that strategy which is best from the point of view of some well-defined measure of quality (for example, minimum energy expenditures, minimum time in motion etc.).

For a look at a system for controlling a specific AM achieving the required positioning precision, Figure 1 shows the generalized structure of a production system automated with the use of AM. Input manipulator control signals are generated on the measurement of certain parameters, which control is based upon a priori information on manipulator characteristics (workpiece mass, speed of movement etc.) as well as upon knowledge of previous changes in input and output signals. Modification of the input control signal is a function of the correction loop which is introduced into the control system.

Manipulator motion may be either perturbed or nonperturbed. We may consider nonperturbed motion as that which occurs without positioning error. This type of motion is easily modeled. Any deviation of manipulator motion from that desired can be thought of as perturbed motion. Analytic manipulator control loop design can be applied in the case of perturbed motion.

Perturbed motion of an AM gripper as a solid body in bound coordinate system $oxyz$ (Figure 2) is described by a system of Euler equations in the form

$$\left. \begin{aligned}
 m \left(\frac{dV_{x1}}{dt} + \omega_{z1} V_{y1} - \omega_{y1} V_{z1} \right) &= \\
 &= F_{x1} - mg \sin \theta_z \cos \theta_x; \\
 m \left(\frac{dV_{y1}}{dt} + \omega_{x1} V_{z1} - \omega_{z1} V_{x1} \right) &= \\
 &= F_{y1} - mg \cos \theta_z \cos \theta_x; \\
 m \left(\frac{dV_{z1}}{dt} + \omega_{y1} V_{x1} - \omega_{x1} V_{y1} \right) &= \\
 &= F_{z1} - mg \sin \theta_x; \\
 I_x \frac{d\omega_{x1}}{dt} + (I_z - I_y) \omega_{y1} \omega_{z1} &= L_x; \\
 I_y \frac{d\omega_{y1}}{dt} + (I_x - I_z) \omega_{x1} \omega_{z1} &= L_y; \\
 I_z \frac{d\omega_{z1}}{dt} + (I_y - I_x) \omega_{x1} \omega_{y1} &= L_z,
 \end{aligned} \right\} (1)$$

where m - mass of gripper and workpiece; V_{x1} , V_{y1} and V_{z1} - components of velocity vector along the coordinates; ω_{x1} , ω_{y1} , and ω_{z1} - components of angular velocity vector of center of mass with respect to the coordinates; L_x , L_y , and L_z - projections on the axis of primary moment of force; F_{x1} , F_{y1} and F_{z1} - projection along axis of resultant force vector and g - acceleration of gravity; θ_x and θ_z - angles of rotation of bound coordinate system; I_x , I_y and I_z - moments of gripper and workpiece inertia along each coordinate.

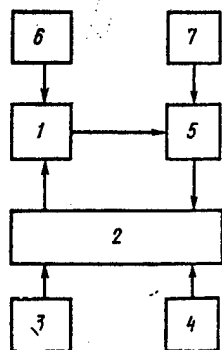

Figure 1. Structural diagram of AM production system. 1 - automatic manipulator; 2 - control system; 3 - production equipment; 4 - a priori information; 5 - measuring system; 6 - environmental perturbations; 7 - measurement noise.

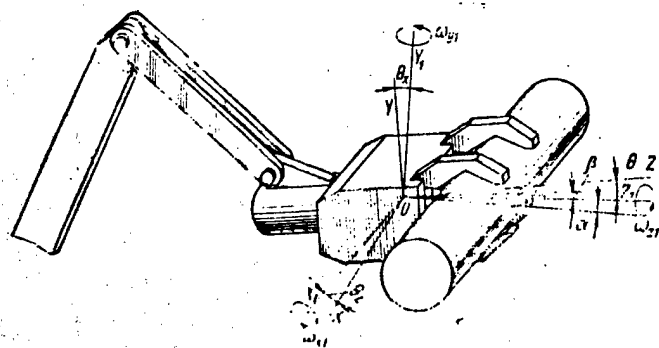

Figure 2. Determination of gripper position in a bound coordinate system.

On the basis of a study of equations 1, 5 and 6 in system (1) and of our method of breaking AM gripper movement down into symmetrical and nonsymmetrical forms it will be established that lateral force F_{x1} and moments L_y and L_z are functions of the coordinates of lateral gripper motion.

$$\left. \begin{aligned} F_{x1} &= f(\alpha); \\ L_y &= f(\omega_{y1}, \omega_{z1}, \alpha, \delta_y); \\ L_z &= f(\omega_{z1}, \omega_{y1}, \alpha, \delta_z). \end{aligned} \right\} \quad (2)$$

where α - horizontal gripper drift angle; δ_y and δ_z - deviations from control moment input relative to axes oy and oz .

To construct a channel for AM gripper drift control, the asymmetrical forms of motion are broken down into plane horizontal lateral drift α and transverse roll with respect to angle θ_x by means of a scheme of plane lateral motion with $\theta_z = 0$.

Through transformation of systems (1) and (2) we can obtain systems of differential equations for the plane lateral drift of an AM gripper. The first equation is written from the condition of equality of the centrifugal force acting upon the manipulator gripper in the case of motion with radius R and the elasticity of lateral drift:

$$\frac{mV^2}{R} = - \left(\frac{\partial F_{x1}}{\partial \alpha} \right) \alpha, \quad (3)$$

where V - total velocity of gripper motion.

We know that $\frac{V}{R} = \omega_{z1} - \frac{d\alpha}{dt}$. On this basis we can write

$$\frac{d\alpha}{dt} + \left(\frac{\partial F_{x1}}{\partial \alpha} \right) \frac{1}{mV} \alpha - \omega_{z1} = 0. \quad (4)$$

We write the second equation from the condition of change in kinetic moment due to the effect of drive elasticity, damping forces and control moment:

$$I_2 \frac{d\omega_{z1}}{dt} = \left(\frac{\partial L_z}{\partial \alpha} \right) \alpha + \left(\frac{\partial L_z}{\partial \omega_{z1}} \right) \omega_{z1} + \left(\frac{\partial L_z}{\partial \delta_z} \right) \delta_z \quad (5)$$

or

$$\begin{aligned} \frac{d\omega_{z1}}{dt} - \left(\frac{\partial L_z}{\partial \omega_{z1}} \right) \frac{1}{I_2} \omega_{z1} - \left(\frac{\partial L_z}{\partial \alpha} \right) \frac{1}{I_2} \alpha = \\ = \left(\frac{\partial L_z}{\partial \delta_z} \right) \frac{1}{I_2} \delta_z. \end{aligned} \quad (6)$$

The dimensionless values in equation (6) are to be understood as corresponding to the following:

$$\begin{aligned} \left(\frac{\partial L_z}{\partial \omega_{z1}} \right) \frac{1}{I_2} & - \text{relative coefficient of damping;} \\ \left(\frac{\partial L_z}{\partial \alpha} \right) \frac{1}{I_2} & - \text{relative coefficient of lateral drift;} \\ \left(\frac{\partial L_z}{\partial \delta_z} \right) \frac{1}{I_2} & - \text{relative coefficient of control.} \end{aligned}$$

To solve this system employing the methods of the calculus of variations we adopt the following designations:

$$\alpha = x_1; \quad \omega_{z1} = x_2; \quad \left(\frac{\partial L_z}{\partial \delta_z} \right) \frac{1}{I_2} \delta_z = U_2.$$

The system of equations takes the following form:

$$\left. \begin{aligned} \frac{dx_1}{dt} + \left(\frac{\partial F_{x1}}{\partial \alpha} \right) \frac{1}{mV} x_1 - x_2 &= 0; \\ \frac{dx_2}{dt} + \left(\frac{\partial L_z}{\partial \omega_{z1}} \right) \frac{1}{I_2} x_2 + \left(\frac{\partial L_z}{\partial \alpha} \right) \frac{1}{I_2} x_1 &= U_2. \end{aligned} \right\} \quad (7)$$

The task of control channel U_2 is to eliminate drift with respect to angle α and damp vibrations with respect to angular velocity ω_{z1} .

According to A. A. Krasovskiy's method, for a linear nonstationary object the functional is written in the form

$$I = \frac{1}{2} \sum_{i, \kappa=1}^n \rho_{i\kappa} x_i x_\kappa + \frac{1}{2} \int_{t_1}^{t_2} \sum_{i, \kappa=1}^n \beta_{i\kappa} x_i x_\kappa dt + \frac{1}{q} \sum_{i=1}^n \int_{t_1}^{t_2} \left(\frac{U_i}{K_i} \right)^q dt + \frac{1}{p} \sum_{\kappa=1}^n \int_{t_1}^{t_2} K_\kappa \sum_{\kappa=1}^n (\rho_{i\kappa} x_\kappa)^p dt, \quad (8)$$

while the optimal equation, which minimizes this functional, takes the form

$$U_i = -K_i \sum_{\kappa=1}^n \rho_{i\kappa} x_\kappa,$$

where $\rho_{i\kappa}$ - coefficient of the quadratic form of optimum control; $\beta_{i\kappa}$ - coefficient of quality of the transient processes; $t_{1, 2}$ - time; p, q - given positive numbers satisfying the relationship $\frac{1}{p} + \frac{1}{q} = 1$; in this instance $p = q = 2$.

As applied to actual AM operation the expression

$$\sum_{i=1}^n \int_{t_1}^{t_2} \left(\frac{U_i}{K_i} \right)^2 dt + \sum_{\kappa=1}^n \int_{t_1}^{t_2} K_\kappa \sum_{\kappa=1}^n (\rho_{i\kappa} x_\kappa)^2 dt$$

acquires a specific physical meaning and becomes the limiting condition

$$\int_{t_1}^{t_2} \left(\frac{U_2}{K_2} \right)^2 dt + \int_{t_1}^{t_2} K_2 (\rho_{21} x_1 + \rho_{22} x_2)^2 dt = C, \quad (9)$$

where $C = \text{const}$; for minimization of the functional

$$I = \rho_{11} x_1^2(t_2) + 2\rho_{12} x_1(t_2) x_2(t_2) + \rho_{22} x_2^2(t_2) + \int_{t_1}^{t_2} (\beta_{11} x_1^2 + \beta_{22} x_2^2) dt.$$

The first term of expression (9) can be thought of as the energy losses occurring in the course of time interval $t_2 - t_1$ at the outputs of the servo device, the second as the work at the input of the servo device.

Solution of system of equations (7) employing A. A. Krasovskiy's method makes it possible to obtain the optimum equation for U_2 :

$$U_2 = K_2 \left(\left(\frac{\partial L_2}{\partial \alpha} \right) \frac{1}{I_2} \alpha + \omega_{21} \right), \quad (10)$$

where

$$K_2 = \frac{1}{\left(\frac{\partial F_{x1}}{\partial \alpha}\right) \frac{1}{mV} \left(\left(\frac{\partial L_2}{\partial \alpha}\right) \frac{1}{I_z} + \left(\left(\frac{\partial L_2}{\partial \theta_x}\right) \frac{1}{I_z}\right)^2 + \left(\left(\frac{\partial F_{x1}}{\partial \alpha}\right) \frac{1}{mV}\right) \left(-\frac{1}{I_z} \left(\frac{\partial L_2}{\partial \omega_{z1}}\right)\right) + \left(-\frac{1}{I_z} \left(\frac{\partial L_2}{\partial \omega_{z1}}\right)\right) \left(\left(\frac{\partial L_2}{\partial \theta_x}\right) \frac{1}{I_z}\right)}.$$

We thus obtain an incomplete degree of controllability: one control response (U_2) and two feedbacks. This system is stable with optimum control with coefficient K_2 approaching ∞ .

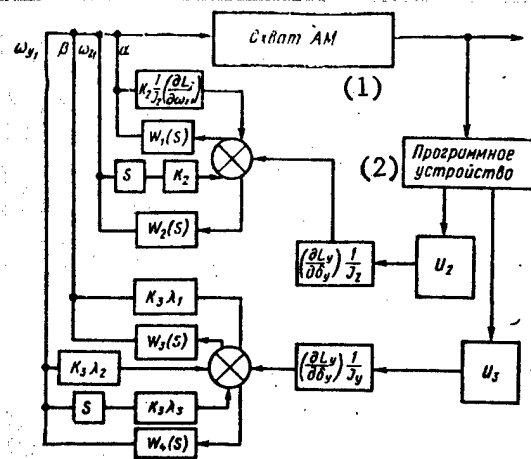

Figure 3. Block diagram of loop for correcting lateral AM gripper drift. 1 - AM gripper; 2 - program unit.

By analogous transformations of initial systems (1) and (2) we obtained an expression for optimum control (U_3) for plane vertical AM gripper drift β in the form

$$U_3 = -K_3(A_1 + A_2 \theta_z + A_3 \theta_x).$$

where K_3 - coefficient of optimum U_3 control amplification; A_1 , A_2 and A_3 - constant coefficients.

The control of the correction of transverse angular gripper deviations thus obtained also has an incomplete degree of controllability - one control response (U_3) and three feedbacks. A synthesized structural diagram of loops for correcting lateral AM gripper drift is shown in Figure 3.

possess the following characteristics:

stability, since with high channel amplification coefficients the optimum controls quickly enough return the system to its initial, or to a near-initial, stable mode of operation following output from it as a result of any response;

invariance with respect to perturbing effects, since upon completion of the transient process the controlled value and system error are to only a very small degree functions of these perturbations with unlimited increase in the coefficient of amplification

and symmetry of optimum controls, that is, low transient-process sensitivity with respect to small changes in the coefficient of amplification.

Introduction of correction loops into an AM control system makes it possible to give virtually any manipulator high positioning precision without increasing the precision involved in the fabrication and assembly of the manipulator itself or enhancing its speed, rigidity or damping characteristics.

COPYRIGHT: Izdatel'stvo "Mashinostroyeniye", "Mekhanizatsiya i avtomatizatsiya proizvodstva", 1981

Production Complex with Automatic Manipulator

Moscow MEKHAUZATSIYA I AVTOMATIZATSIYA PROIZVODSTVA in Russian No 11, 1981 (signed to press 23 Oct 81) pp 8-11

[Article by G. A. Melet'yev, Candidate of Technical Sciences, and I. I. Anuchin, M. L. Popov and V. D. Shchepin, engineers: "Production Complex with Automatic Manipulator"]

[Text] Our country has now built a large number of automatic manipulators (AM) with program control designed for the task of loading metal-cutting machines. Particularly effective is the use of AM in combination with other production equipment, which creates the possibility of full production mechanization and automation.

Employed, for example, in existing production systems making parts such as sleeves are two IA240P-6 semiautomatic lathes, each of which has an automatic operator. This production complex consists as well of conveyor systems for transporting workpieces from one machine to another, a device for manipulating the workpieces, feeders and storage cradles. All these devices are very cumbersome, offer poor mobility and occupy substantial production area.

Resulting from an analysis of the process involved in machining bushing-type pieces on the two IA240P-6 semiautomatic lathes was the proposal to build the mod. SPM-MPI automatic manipulator, which loads machines with workpieces from a magazine loader, conveys partially machined pieces from one machine to another, removes pieces on which machining has been completed and packs them for storage in containers, that is, it fully automates the workpiece machining cycle.

The need for AM in this kind of production complex arises from the following considerations:

the fact that these pieces have developed cylindrical surfaces providing reliable gripping and holding points during the process of conveying them and of loading and unloading machines;

the roughly equal periods of time required to machine a piece on each semiautomatic lathe, which makes it possible to load two machines simultaneously

and the possibility of liberating a part of the work force and floor space involved.

The production complex (Figure 1) consists of two IA240P-6 machines, 1 and 2, positioned side by side and machining bushing components in two steps; a two-armed AM 3 having three degrees of motion (rotation of the column around its vertical axis, extension of the mechanical arms and the motion of the grippers) and the signal to begin the manipulation process from the machines; a magazine loader 4 with a capacity of roughly 300 workpieces serving to store individual pieces and then to move them from storage to a cradle [tray]; a cradle 5 for feeding billets (workpieces) to a device which distributes them individually; a cradle 6 for conveying finished pieces to container 7; a

special container for storing finished pieces; a hydraulic pumping system 8 equipped with hydraulic devices to drive the AM's servo mechanisms; an electrical equipment compartment with a control console 9 and a cyclical system to control the entire complex and a workpiece feed device 11 designed to move the individual workpieces into the working area of the AM gripper.

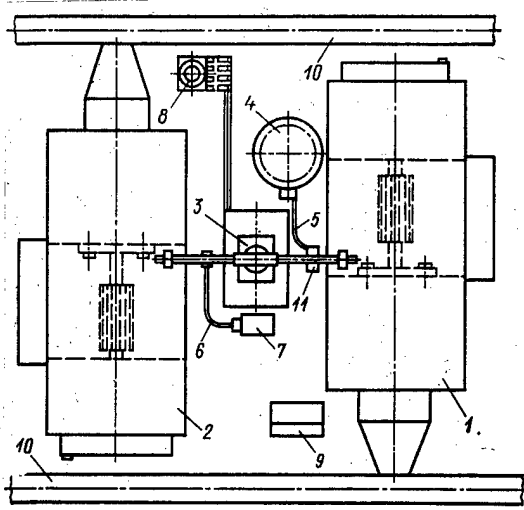

Figure 1. Diagram of production complex with mod. SPM-MPI automatic manipulator.

The complex functions as follows: after the machines have completed their workpiece machining cycle, sensors monitoring for completion of machining cycle, which are located on the machines, send a signal to the AM mechanical arm extension device and the devices moving the grippers, which then grip and remove the workpieces from the collet chucks of both machines simultaneously (gripping the workpieces by the exterior surfaces); the mechanical arms relax, and the gripper releases the finished piece, which is then transferred by cradle 6 to the finished workpiece storage container. After the gripper releases the finished piece the AM column rotates clockwise 180° around its vertical axis, and the sensors monitoring column rotation send a signal to the magazine loader to advance another workpiece for transfer by cradle 5 to the workpiece feed device.

The free gripper grasps the workpiece and upon command from grip control sensors (pressure relays) the mechanical arms move to load the machines: a workpiece into the collet chuck of machine 1 and the piece partially worked on the first machine into the collet chuck of machine 2. After the machines have gripped the workpieces the AM withdraws its mechanical arms and brings them together. The workpiece machining cycle is then repeated, and the manipulator column now rotates 180° counterclockwise. Turnings from the machines are removed by screw conveyors 10.

The proposed design for a production complex for automating the machining of bushing-types pieces using automatic manipulators makes it possible to dispense with the two automatic operators and a cumbersome and material-intensive transfer system and to reduce the area required for production operations. The economic gain achieved from the introduction of production systems employing AM in operations involved in the automatic machining of pieces like this is 18,500 rubles. The system is being introduced in one of the enterprises in the Mari ASSR.

The automatic manipulator (Figure 2) consists of a stationary base 1 housing the column-rotating mechanism, which consists of two hydraulic cylinders, within which are rack pistons 2 and 3, which with gear 4 form a system of rack-and-pinion gearing. The gear is rigidly keyed to exteriorly scrolled shaft 5, which serves as the movable component of collector 6 designed to feed and receive working fluid to and from the manipulator's servo mechanisms. Separation of radial thrust bearings 7 and 8 at the ends of the shaft make it possible to make the AM column more stable in its stationary base.

Rigidly attached to the shaft is hydraulic distributor unit 9, upon which is mounted the vertical column cylinder 10. Rigidly attached to the top of the vertical column is plate 11, with which are articulated the two mechanical arms 12 with grippers 13 and gripper actuators 14, the grippers moving in planes perpendicular to the axes of the arms. Flexible lines 15-17 are linked via connectors with main lines 18 housed within the vertical column and linked via connectors as well with the hydraulic distributor unit.

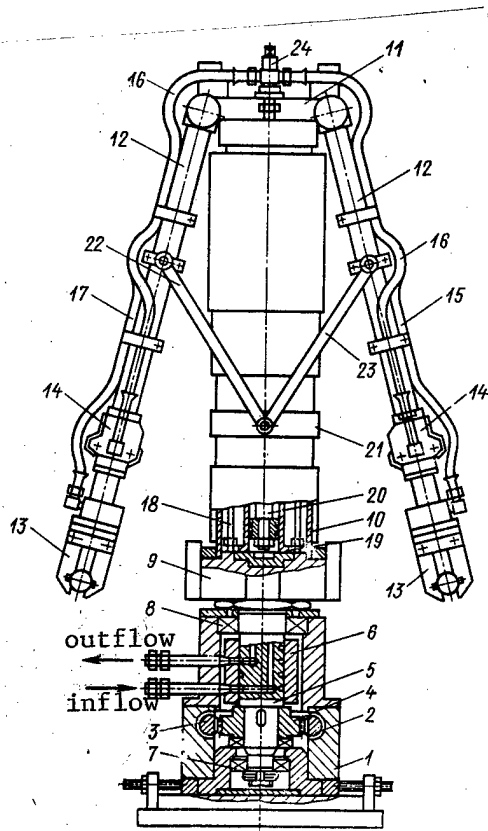

Figure 2. Mod. SPM-MPM [sic] automatic manipulator.

through the slide, and by means of the two pairs of supporting rods articulated with it, extends the arms.

The arms are brought together in an analogous manner, with the one difference that the working fluid enters the rod chamber of hydraulic cylinder 20.

All other servo mechanisms of the manipulator are also supplied with working fluid via the collector, from which by way of the corresponding hydraulic distributors and hydraulic distributor unit channels the working fluid flows through the main lines 18 and via

The mechanism for extending the mechanical arms consists of a differential hydraulic power cylinder 19 attached by the lower end of a rodless chamber to the hydraulic distributor unit. Hydraulic cylinder rod 20 is connected to slide 21, which travels along the axis of the vertical column. Articulated with the slide are two pairs of rods 22 and 23 which support the manipulator arms. Regulator screw 24 limits the angle to which the manipulator's mechanical arms are extended.

The manipulator rotates around its vertical axis in the following manner. Working fluid fed into the hydraulic cylinders activates pistons 2 and 3, thus rotating gear 4, which is rigidly connected via the keyed joint of the shaft to the vertical column of the manipulator, thereby rotating it by a certain precisely fixed angle.

The mechanical arms are extended by fluid fed via an input connector to a corresponding channel on the shaft, which is the movable component of the collector, and on via axial shaft boring to the corresponding hydraulic distributor. Upon reaching the rodless chamber of hydraulic cylinder 19, the fluid actuates the rod, which

connectors and flexible lines 15-17 to the hydraulic cylinders of the gripper device and the hydraulic cylinders 14 actuating the grippers functioning simultaneously.

This design thus eliminates overhanging loads, enhances the dynamic characteristics of the mechanical system and offers the possibility of a parallel machining cycle in which the same piece is worked on two machines.

All manipulator mechanisms function with rigid stops.

Basic AM Specifications

Lifting capacity, kg	10
Number:	
of degrees of motion	3
of arms	2
of machines which can be serviced simultaneously ..	2
Acceptable workpiece diameter, mm	60 - 120
Acceptable workpiece length, mm	40 - 150
Type of drive	hydraulic
Hydraulic unit	standard 8/25 G48-12 pump
Positioning accuracy, mm ...	±1
System of basic movement coordinates	spherical
Minimum distance from manipulator base to center of gripper, mm	654
Maximum distance from manipulator base to center of gripper, mm	1120
Angle, deg:	
of mechanical arm close ..	25
of mechanical arm extension ..	65
Workpiece travel along gripper center axis, mm	50
Control system	cyclical
Maximum rate of manipulator column rotation, deg/s ..	180
Maximum speed, mm/s:	
of arm close	560
of arm extension	320
of gripper travel along machine center axis	120
Overall dimensions, mm	620x960x1650

The manipulator's hydraulic system permits transition from rapid movement to "creeping" (reference) speed at the end of the path of the mechanisms governing the most critical AM movements, upon which depend positioning accuracy.

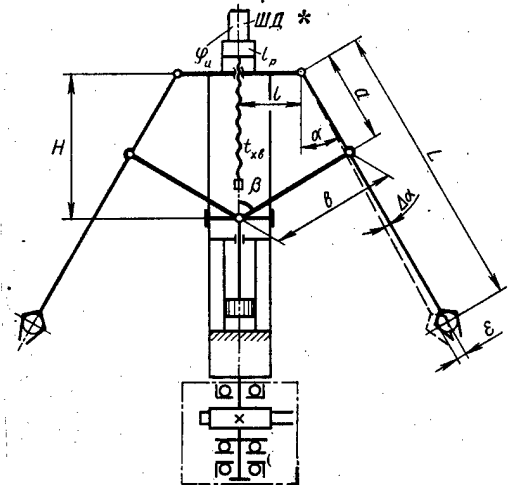

Figure 3. Kinematic diagram of mod. SPM-MPI automatic manipulator. * - stepper motor.

The manipulator is equipped with an adjustment device, which is mounted at the base to regulate movement with precise adjustment between the pivots of the machine loading positions.

Position sensors (directional switches) located at the end of the actuator track generate signals for subsequent manipulator movements.

All manipulator mechanisms are equipped with regulating devices providing precision manipulation of the gripper.

The possibility of using an AM to automate the process of loading and unloading horizontal IA240P-6 semiautomatic chucking lathes with individual workpieces is governed to a great extent by the kinematic precision of the movements of its servo components. It is therefore necessary analytically to determine the parameters of the regulating elements providing the required kinematic precision. In the case of the AM design here under consideration it will be important in this connection to determine the angle of mechanical arm extension, proceeding on the basis of the condition that we insure the required discrete movements.

Let us now look at a kinematic diagram of the manipulator (Figure 3). We have adopted the following letter designations:

- a - distance between point at which the arm is articulated with the column and that at which the support rod is articulated with the arm;
- L - arm length from center of articulation with the column to the center of the gripper (center of workpiece);
- b - length of support rod;
- H - distance between point at which rod is attached to column slide and a line through the point at which the arm articulates with the upper plate on the manipulator column;
- l - distance between center of column and center of articulated arm attachment.

Let us now derive the law governing the change in H as a function of angle of rotation α . Let us assume that all manipulator components are absolutely rigid and that there are no gaps between members. From plots on our graph it follows that

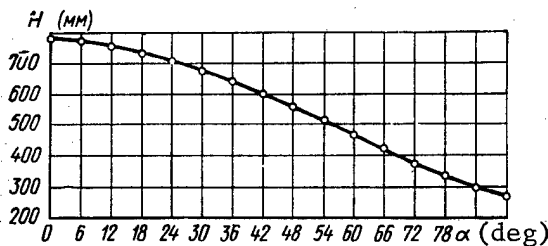

$$H = a \cos \alpha + b \cos \beta; \quad (1)$$

$$\sin \beta = \frac{l + a \sin \alpha}{b}. \quad (2)$$

Figure 4. Graph of the function $H = f(\alpha)$.

Employing the known trigonometric expressions, let us transform (1)

$$H = a \cos \alpha + b \sqrt{1 - \sin^2 \beta}; \quad (3)$$

$$H = a \cos \alpha + \sqrt{b^2 - (l + a \sin \alpha)^2};$$

Since

$$2al \sin \alpha - 2aH \cos \alpha = b^2 - l^2 - a^2 - H^2. \quad (3)$$

Since a, b and l are constant manipulator design parameters, we can say that $b^2 - l^2 - a^2 = M$. Substituting, equation (3) takes the form

$$2al \sin \alpha - 2a \sqrt{1 - \sin^2 \alpha} H = M - H^2 \quad (4)$$

or

$$H^2 - 2aH\sqrt{1 - \sin^2 \alpha} + (2al \sin \alpha - M) = 0. \quad (5)$$

Employing the known formulas for finding the roots of a quadratic equation, let us compute the single value

$$H = a\sqrt{1 - \sin^2 \alpha} + \sqrt{a^2 + M - a \sin \alpha (a \sin \alpha + 2l)}. \quad (6)$$

On the basis of (6) let us now plot adjustment curve $H = f(\alpha)$ (Figure 4) employing the following constant design parameters: $a = 300$ mm; $b = 500$ mm; $l = 125$ mm; $M = b^2 - l^2 - a^2 = 144,375$ mm²;

$$H = 300\sqrt{1 - \sin^2 \alpha} + \sqrt{234375 - 90000 \sin^2 \alpha - 75000 \sin \alpha}.$$

Let us now compute the limits of the change in angle α for the case when $a+l > b$. From the kinematic diagram of the manipulator we can see that angle α can have the extremum values

$$\alpha_{\min} = 0^\circ; \quad \alpha_{\max} = \arcsin \frac{b-l}{a}. \quad (7)$$

Given the known design parameters a , b and l

$$\begin{aligned} H_{\min} &= a \sqrt{1 - \frac{(b-l)^2}{a^2}} + \sqrt{a^2 + M - a \frac{(b-l)}{a}} \times \\ &\times \sqrt{\left[a \frac{(b-l)}{a} + 2l \right]} = \sqrt{a^2 - (b-l)^2} + \\ &+ \sqrt{a^2 + M^2 - (b-l)(b-l+2l)} = \sqrt{a^2 - (b-l)^2}. \end{aligned}$$

To compute regulating component parameters: guide screw pitch t_{gs} and minimum angular movement of discrete motor, in which instance stepper motors may be employed, we must compute the minimum discrete value of angular manipulator mechanical arm movement $\Delta\alpha$. The minimum value $\Delta\alpha$ of angular mechanical arm movement may be computed from the condition that we insure proper fit with respect to the interior (exterior) surfaces of the workpiece and the chuck on the loading shaft of the machine

$$\delta = \left| D_w - D_c \right|,$$

where δ represents the gap between the workpiece and the chuck; D_c the exterior diameter of the chuck and D_w the interior diameter of the workpiece

We know that in the case of automatic assembly "fit" refers to the probability of 100-per cent assembly of all components "into a single unit with satisfaction of all quality requirements."

We insure fit if we satisfy the following relationship

$$\epsilon \leq \epsilon_{\text{per}}$$

where ϵ represents total error in the relative position of the axes of the assembled components and ϵ_{per} the maximum permissible error in the mutual positioning of the axes at which joining or connecting is still possible.

If we assume the base component to be stationary (the collet chuck of a machine as in our case, for example), the error in the relative positioning of the axes of the components to be assembled is determined by the error in the positioning of the servo mechanism (the arm in this instance) of the AM. ϵ_{per} may then be considered identical to the permissible error in manipulator positioning. We compute ϵ_{per} from the dimensions of the components to be joined and the rigidity of the components of the positioning devices without taking into account the face on the collet chuck

$$\epsilon \leq \epsilon_{\text{per}} = \frac{z_{\text{n.m.}}}{2} = \frac{\delta}{2}$$

where $z_{\text{n.m.}}$ represents the minimum gap in the connection.

The minimum value of angular motion $\Delta\alpha$ is then determined from the kinematic diagram of the manipulator (see Figure 3)

$$\epsilon/2 = L \sin \Delta L/2; \quad (8)$$

$$\Delta\alpha = 2 \arcsin \epsilon/2L \quad \bullet \quad \Delta\alpha = 2 \arcsin \delta/4L. \quad (9)$$

At the same time

(10)

After computing the minimum value of the angle of manipulator arm rotation $\Delta\alpha$ in accordance with (9) and the value α_{max} , computed from (7), we can compute any actual value α_i and subsequent α_{i+1} in accordance with (10). The value of the linear motion of the regulating component will then be computed from the condition

$$\Delta H = H_{i+1} - H_i \quad (11)$$

where

$$H_i = a \sqrt{1 - \sin^2 \alpha_i} + \sqrt{a^2 + M - a \sin \alpha_i (a \sin \alpha_i + 2l)};$$

$$H_{i+1} = a \sqrt{1 - \sin^2 \alpha_{i+1}} +$$

$$+ \sqrt{a^2 + M - a \sin \alpha_{i+1} (a \sin \alpha_{i+1} + 2l)},$$

then

$$\Delta H = a \left(\sqrt{1 - \sin^2 \alpha_{i+1}} - \sqrt{1 - \sin^2 \alpha_i} \right) +$$

$$+ \frac{\sqrt{a^2 + M - a \sin \alpha_{i+1} (a \sin \alpha_{i+1} + 2l)} - \sqrt{a^2 + M - a \sin \alpha_i (a \sin \alpha_i + 2l)}}{1} \quad (12)$$

As we can see from adjustment curve $H = f(\alpha)$, ΔH for different ranges of variation in arm rotation angle α will also vary; the minimum value of the linear motion of the regulating component ΔH_{min} must therefore be computed from the extreme condition

$$\Delta H = n \Delta H_{\min}, \quad (13)$$

where $n = 1, 2, 3, \dots$; m represents any whole number.

We can then find the parameters of the regulating component for remote control in accordance with the known formula

$$t_{\text{H}} = \frac{\varphi_{\text{H}}}{360} i_{\text{P}} t_{\text{x.B}}, \quad (14)$$

where $t_{\text{H}} = \Delta H_{\min}$ - pulse value equal to minimum value of linear motion; φ_{H} - angle of stepper motor rotation corresponding to a single pulse (deg); i_{P} - reducer gear ratio; $t_{\text{x.B}}$ - guide screw pitch.

It follows from (14) that

$$t_{\text{x.B}} = \frac{360 \Delta H_{\min}}{\varphi_{\text{H}} i_{\text{P}}}. \quad (15)$$

The work which has been done has provided a basis for the development of analytical computation of regulating component parameters based upon the criterion for determining component fit. Adjustment curve $H = f(\alpha)$ makes it possible to compute the low-sensitivity regulation zones throughout the angle of mechanical arm extension and can be employed with manual or remote AM adjustment.

Copyright: Izdatel'stvo "Mashinostroyeniye", "Mekhanizatsiya i avtomatizatsiya proizvodstva", 1981

8963

CSO: 1823/2

END