

291106

JPRS 81679

1 September 1982

19980915 149

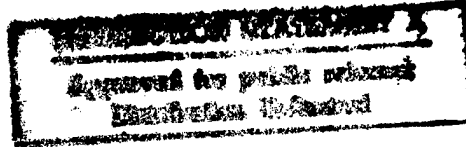

China Report

POLITICAL, SOCIOLOGICAL AND MILITARY AFFAIRS

No. 333

ANTIBALLISTIC MISSILE WEAPONS

By

Liu Shaoqui and Li Xianlin



FOREIGN BROADCAST INFORMATION SERVICE

REPRODUCED BY
 NATIONAL TECHNICAL
 INFORMATION SERVICE
 U.S. DEPARTMENT OF COMMERCE
 SPRINGFIELD, VA. 22161

10
62
A04

NOTE

JPRS publications contain information primarily from foreign newspapers, periodicals and books, but also from news agency transmissions and broadcasts. Materials from foreign-language sources are translated; those from English-language sources are transcribed or reprinted, with the original phrasing and other characteristics retained.

Headlines, editorial reports, and material enclosed in brackets [] are supplied by JPRS. Processing indicators such as [Text] or [Excerpt] in the first line of each item, or following the last line of a brief, indicate how the original information was processed. Where no processing indicator is given, the information was summarized or extracted.

Unfamiliar names rendered phonetically or transliterated are enclosed in parentheses. Words or names preceded by a question mark and enclosed in parentheses were not clear in the original but have been supplied as appropriate in context. Other unattributed parenthetical notes within the body of an item originate with the source. Times within items are as given by source.

The contents of this publication in no way represent the policies, views or attitudes of the U.S. Government.

PROCUREMENT OF PUBLICATIONS

JPRS publications may be ordered from the National Technical Information Service, Springfield, Virginia 22161. In ordering, it is recommended that the JPRS number, title, date and author, if applicable, of publication be cited.

Current JPRS publications are announced in Government Reports Announcements issued semi-monthly by the National Technical Information Service, and are listed in the Monthly Catalog of U.S. Government Publications issued by the Superintendent of Documents, U.S. Government Printing Office, Washington, D.C. 20402.

Correspondence pertaining to matters other than procurement may be addressed to Joint Publications Research Service, 1000 North Glebe Road, Arlington, Virginia 22201.

1 September 1982

CHINA REPORT
POLITICAL, SOCIOLOGICAL AND MILITARY AFFAIRS

No. 333

ANTIBALLISTIC MISSILE WEAPONS

Beijing FANDAODAN WUQI [ANTIBALLISTIC MISSILE WEAPONS] in Chinese
Aug 81 unnumbered introduction, table of contents, pp 4-75

[Introduction, table of contents and chapters 2-8 of book
"Antiballistic Missile Weapons" by Liu Shaoqui [0491 4801 3808] and
Li Xianlin [2621 7341 7207] published by National Defense Industries
Press, 100 pages]

[Text] Introduction

It is an objective law of development that every form of attack has its corresponding defense.

The appearance of every new advanced weapon inevitably results in the development of a weapon to defend against it. Antiballistic missiles, which are intended for defense against nuclear ballistic missiles, are still under development.

The antiballistic missile is an extremely large, complex, costly weapon system involving a wide range of technologies. The United States took 20 years and spent a total of more than US \$10 billion to produce the Safeguard system, which nonetheless had low effectiveness and was taken out of service in February, 1976.

This book presents a systematic introduction to antiballistic missile systems. It is divided into ten chapters. The first eight describe the organization, capabilities, interception process and guidance principles of the systems, penetration and antipenetration techniques, and the design and characteristics of the antiballistic missiles themselves. Chapter 9 describes other approaches to ballistic missile defense such as laser weapons, particle beam weapons and the like. Chapter 10 describes the status of certain foreign antiballistic missile systems and discusses trends in the development of such systems.

Prof Shi Chaoli [0670 6389 4409] and Comrade Shen Zhongfang [3088 1813 5364] read the manuscript carefully and many valuable comments, Comrade Chen Mingdi [7115 2494 1717] did much work associated with the writing of the book, and Comrades Chang Bozhi [1728 0590 2535] and Lu Zheng [7120 6154] drew the diagrams and the cover illustration for the book; we take this opportunity to express our gratitude to them.

Because antiballistic missile systems involve an extremely wide range of technologies and our own abilities are limited, the book may contain errors; readers' corrections and criticisms are earnestly solicited.

Data on US and Soviet antiballistic missile systems presented in the text are drawn from open foreign publications; since different publications sometimes present conflicting figures, the data presented here should be used for reference only.

[Translation of] Table of Contents

Chapter 1.	An Overview of Antiballistic Missile Systems	1
Chapter 2.	The Organization and Capabilities of Antiballistic Missile Systems	4
	Warning Systems	5
	Target Recognition Systems	6
	Ground-Based Guidance Systems	7
	The Antiballistic Missile: The Interceptor Component of the System	8
	Command and Control Systems	9
Chapter 3.	The Missile Intercept Process	12
	Simplified Description of the Target Interception Process	12
	Time Allocation in the Engagement Process	14
	Six minutes, and 6.5 Seconds	16
Chapter 4.	Guidance Principles	19
	The Intercept Path	20
	Guidance Principles	24
Chapter 5.	Design and Characteristics of the Antiballistic Missile	29
	General Design	29
	Characteristics of the Antiballistic Missile	29
	Some Foreign Antiballistic Missiles	36
Chapter 6.	The Command Center: The "Brain" of the Antiballistic Missile System	40
	The Functions of the Command Center	41
	Capabilities of Electronic Computers	44
Chapter 7.	Warning Systems and the "Far-Seeing Eye" of Radars	49
	Warning Satellites	50
	Radar, the "Far-Seeing Eye"	53
	Over the Horizon Radar	55
	Phased Array Radars	58
	Monopulse Radars	60
Chapter 8.	Penetration and Antipenetration Techniques	66
	A Survey of Penetration and Antipenetration Techniques	66
	Several Penetration Techniques	68
	Recognition Techniques	72

Chapter 9. Other Ways of Intercepting Missiles	76
Brief Descriptions of Interception Methods	76
Laser Weapons	77
Particle Beam Weapons	84
Chapter 10. Current Status and Development Prospects of Foreign Antiballistic Missile Systems	90
The Status of US Antiballistic Missile Research	90
Soviet Antiballistic Missile Weapons	95
Future Prospects of Antimissile Systems	97
Tables	
Table 1. Ballistic Characteristics of Ballistic Missiles	99
Table 2. Subdivisions of the Radio-Frequency Spectrum	100
Table 3. Characteristics of US Antiballistic Missile Weapons	100

Map

Chapter 2. Organization and Capabilities of Antiballistic Missile Systems

Antiballistic missile systems are assigned the mission of destroying attacking ballistic missiles (intermediate range, long range and intercontinental ballistic missiles) and other attack weapons and protecting military objectives, important industrial cities, missile silos and other targets from enemy attack. In addition, their warning systems may take on some of the air defense warning mission.

Specifically, antiballistic missile systems have the following tasks.

1. Detecting incoming targets as early as possible, accurately computing their trajectories and furnishing the antiballistic missiles with sufficient warning time. If incoming enemy aircraft are detected as soon as they take off, our own squadrons have more time to prepare to intercept them, and the probability of destroying them is increased. This is even more true of high-speed attacking missiles: the longer the warning time, the greater the probability of destroying them.
2. After target acquisition, they must use the data obtained by the warning system to recognize and discriminate targets and determine whether they are missiles, satellites or false targets. False targets may be ignored, while no missile warheads or other attackers must be allowed through.
3. The antiballistic missile must be guided to intercept of the target and must destroy all attacking "enemies."
4. All commands must be rapidly transmitted and all target information that has been obtained (including target characteristics, trajectory data and the like) must be processed rapidly.
5. The intercept results must be evaluated so as to determine whether more firepower should be organized for an intercept.

Antiballistic missile systems generally consist of a warning system, a target recognition system, a ground-based guidance system, a command and control system and antiballistic missiles, as shown in Figure 2.1.

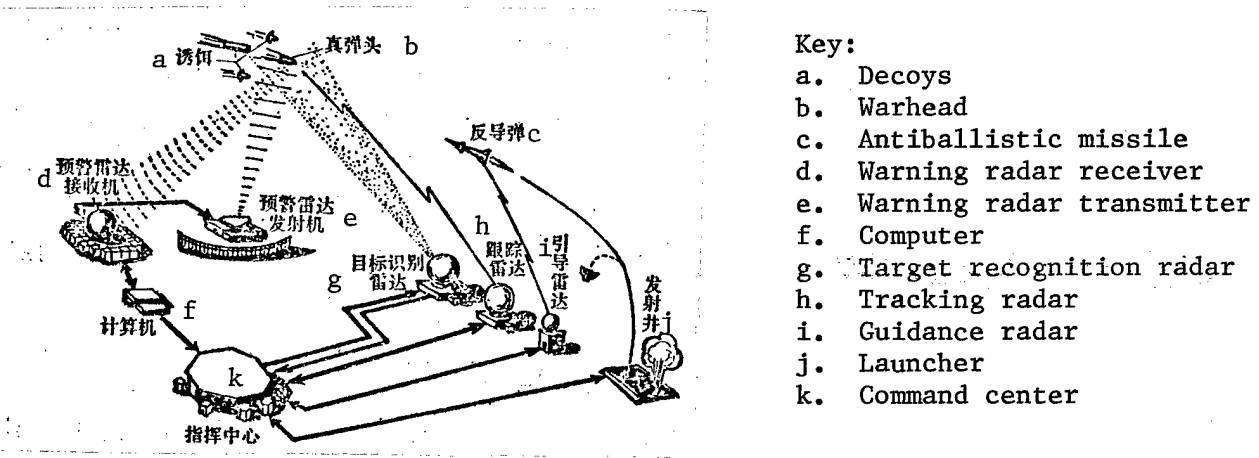

Fig. 2.1. Antiballistic missile system

What are the functions of the main components of antiballistic missile systems? Must they be this complex? To answer these questions requires some understanding of the functions of the components or systems.

Warning Systems

Antiballistic missile systems have highly capable, sensitive "eyes" which constantly monitor enemy ICBM launch sites. Even the launch of a wily "enemy" (a missile) 10,000 kilometers away cannot escape detection by these "eyes." The "eyes" are called warning systems. They are a prerequisite for interception of targets by antiballistic missile systems.

Warning systems have the mission of detecting, providing warning of locking onto and tracking targets. In the immensity of the skies, warning systems constantly monitor possible sudden enemy attacks, detect missiles and other attack weapons in flight or at launch, make a rough determination of the targets' trajectories and the areas that are threatened, and furnish the antiballistic missile system with as much time as possible to prepare.

Warning systems generally include warning satellites, over-the-horizon radars, long-range surveillance and tracking radars and the like.

A warning system consists of several stations (tracking or monitoring stations) which may be distributed over an entire country or several regions in a weblike network; the warning systems are accordingly also called warning networks.

The question of how warning systems detect incoming targets is left for discussion in Chapter 7.

Target Recognition Systems

"One day the warning system suddenly discovered an incoming enemy warhead, and all of the country's missiles, antimissile systems and aircraft were on a hair-trigger alert. It seemed that a major war was inevitable; many persons were terrified and looked for shelter."

This situation actually occurred many years ago in the United States because its warning system malfunctioned, mistaking an aurora display for incoming warheads and giving a false alarm.

We can see from this instance that in addition to being absolutely reliable, a warning system must also be capable of recognizing targets.

In order to avoid detection and tracking by the warning system, incoming targets may resort to certain tricks such as releasing dummy targets (also called decoys or chaff, e.g. balloons, metal wire, metal foil and the like) and concealing themselves within this crowd of targets (Fig. 2.2). This obviously makes it difficult for the warning system to carry out its mission and "confuses its vision." Under these circumstances the important thing is target recognition.

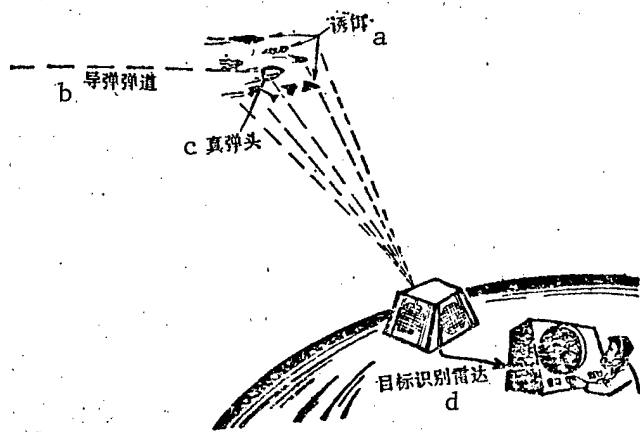

- Key:
- a. Decoys and chaff
 - b. Missile trajectory
 - c. Warhead
 - d. Target recognition radar

Fig. 2.2. "Enemy" hidden in a target cluster

Target recognition requires that false targets be distinguished from missile warheads. The system with this task is called the target recognition system.

Target recognition can be carried out by separate target recognition equipment such as radars or laser systems or can be performed by the target tracking radars themselves.

Correct target recognition requires that the recognition equipment have very high resolution so that auroras or satellites will not be mistaken for incoming warheads and so that warheads will not be mistaken for false targets.

There are many recognition techniques; the two most common are described in Chapter 8.

Ground-Based Guidance Systems

Before a rifle is fired it must be aimed, as everyone knows. A rifle is sighted by means of the front and rear sights.

The system which guides an antiballistic missile to its target is called the guidance system. The function of the guidance system is equivalent to the function of sights on a rifle. Because the guidance system is rather complex and is located on the ground or underground, it is also called the ground-based guidance system.

The ground-based guidance system's main tasks are to track and vector the antiballistic missile, guiding it directly to its target. Accordingly it is a fast, precise system. It consists of the ground-based launching equipment, the target tracking radar and the antiballistic missile guidance radar.

In simplified terms, the operation of the ground-based guidance system is as follows. Using the target information supplied by the warning system, the

target tracking radar continuously monitors the precise position, velocity and other ballistic parameters of the target, transmits them sufficiently in advance to the command and control center and the ground-based guidance system, controls the launching of the antiballistic missile, and then tracks the relative position and speed of the antiballistic missile and its target, formulates control instructions by means of a fast computer, transmits these instructions to the automatic pilot device of the antiballistic missile, and accurately guides and controls the antiballistic missile so that it flies to and intercepts the target. More simply, it tracks the target, launches the antiballistic missile, and guides it to interception of the target.

The antiballistic missile guidance radar (i.e. the ground-based guidance radar) has the main task of guiding the antiballistic missile to an accurate intercept of the target. It uses the target trajectory information furnished by the target tracking radar to track designated targets and also guides high-altitude or low-altitude antiballistic missiles to their targets. In the case of low-altitude interceptor missiles, target data must be received 20 seconds before launch, when the target is about 100 kilometers from the guidance radar station, so that control commands can be formulated.

The Antiballistic Missile: The Interceptor Component of the System

The term "fandaodan" [0646 1418 1734] is an abbreviation of "fandandao daodan" [4606 1734 6670 1418 1734], "antiballistic missile." This is the interceptor component of the antiballistic missile system and constitutes one measure for intercepting incoming targets; others are described in Chapter 9. Like the projectiles of an anti-aircraft gun, it directly destroys the target. Antiballistic missiles are usually divided into high-altitude and low-altitude types, which are used against high-altitude and low-altitude targets respectively. The former type is called a high-altitude interceptor and the latter type a low-altitude interceptor. The high-altitude interceptor destroys groups of targets at altitudes greater than 100 km (including true and false targets) to protect an entire area (which includes military installations, important cities, industrial centers and ICBM bases) and constitutes the first line of antimissile defense. The US Spartan (intercept altitude 160-480 km) and the Soviet Galosh missiles are high-altitude interceptors.

Low-altitude interceptors intercept all targets which have penetrated the high-altitude intercept area (the first line of defense) and have descended to low altitudes. They constitute the second, and currently the most important, line of defense. The US Sprint antiballistic missile (intercept altitude 32-48 km) is a low altitude antiballistic missile.

What are the characteristics of high-altitude and low-altitude interceptors (ABM's)? Of what do they consist? These questions are answered in Chapter 5.

Command and Control Center

Since the beginning of military history, command and control have always been an important part of warfare.

Like the human brain, the command and control system of an antiballistic missile system controls all components of the system and coordinates their operation so that they are knit together into unified whole and constitute an effective weapon for destroying incoming targets.

For example, when the warning system furnishes target information and recognition is carried out by the target recognition system, the command and control center must rapidly make a correct engagement decision. The commander uses the command and control system to order the launching of missiles (high-altitude missiles first, then low-altitude missiles) to engage the target. The ground-based guidance system uses target information (ballistic data) to make continuous corrections in the missile's trajectory and guide it unerringly to the target.

Today, when advanced modern weapons are available, their great attack speeds and destructive capabilities compel the belligerents to make rapid decisions and to react quickly, which requires that antiballistic missile command and control systems be highly reliable, fast, accurate, flexible and survivable.

Command and control systems generally include command components (the command center), communications components (communications stations), and data processing components.

The command center (command post) is the brain of the antimissile system, the decisionmaking organ, which is in charge of issuing orders and messages and commanding and allocating the activity of the various systems.

In the movies we have seen communications troops carrying messages on horseback: this is a common communications technique of great antiquity.

Communications systems constitute the "nerves" along which information is sent between the various subsystems of an antiballistic missile system. All information is rapidly exchanged between communications stations in order to assure free and uninterrupted communications between all systems.

The communications system must be fast, accurate, reliable and secure; it is a completely automated system. An example from World War II makes clear the importance of security and reliability. On 18 April 1943, the telegraphic code of the Japanese High Command was broken by US intelligence, with the result that Japanese Admiral Yamamoto was shot down and killed by US pilots over Bougainville. This was an outstanding air victory of the war.

The term "data processing" refers primarily to the processing of various types of measurement information. From the target data obtained by the warning radar to the target intercept, all measurement data are rapidly computed and processed (e.g. by data smoothing and the like) in order to determine the correct positions and speeds of various targets and to assign the priorities for destruction of targets within a group.

The aim of data processing is to assure that target data obtained by the radars are completely reliable. Because the data from the radars include various kinds

of errors, mathematical methods of processing must be employed to remove them. If the data are smoothed or filtered, the errors can be removed, assuring that they will be reliable.

The tools of data processing are electronic computers which are fast, have large capacity and permit no errors, because a computer malfunction or computation error could produce a disaster. Accordingly, data processing systems have automatic diagnostic capabilities to eliminate any possible malfunctions and to assure that the computation results will be correct.

This has been a brief description of the main components of antiballistic missile systems.

Chapter 3. The Missile Intercept Process

An ICMB is a sophisticated modern weapon consisting of tens of millions of components; an antiballistic missile is also a modern, complex, sophisticated system and consists of even more components.

For these complicated antiballistic missile systems to destroy incoming ballistic missiles, they must carry out warning, recognition, tracking and interception. If these four system components are controlled and coordinated, and their firepower used effectively, they can destroy the "enemy" and intercept all incoming targets.

Simplified Description of the Process of Target Interception

How does an antimissile system intercept a target?

Warning. The warning system (such as warning satellites, over-the-horizon radars and the like) unceasingly searches and maintains surveillance over the immensity of space and monitors enemy missiles (missiles launched from silos, from flying aircraft and from submarines).

If a warning satellite or over-the-horizon radar detects a target, the warning system immediately sends out an alarm and the long-range radar begins the process of target acquisition and tracking, makes a rough calculation of the target's trajectory and point of impact, and estimates the degree of danger and the size of the endangered area. If the incoming warhead will fall in the defended area, the warning radar transmits the target ballistic data to the air defense command center, thus completing its warning task.

Target Recognition. The target recognition system uses the target data supplied by the warning system to track and recognize the target. The target recognition system performs a target characteristics analysis on the information obtained for all targets (e.g. target motion characteristics, shape and so on), distinguishes the individual targets within a group, eliminates false targets such as satellites, meteors and auroras, recognizes incoming warheads, calculates their numbers and trajectories, assigns priorities to real targets (warheads) and transmits the information in timely fashion to the command center.

Tracking. The long-range precision tracking radars continuously track the targets, determine their trajectories accurately and process such monitoring data as target range, bearing, elevation and rate of change of distance (i.e. velocity) to eliminate measurement error (generally caused "measurement noise" by engineers), determine accurately the target trajectories, and estimate the intercept point and point of ground impact.

Interception. The command center makes decisions on the basis of the information on all targets, and when it has determined that the incoming warheads will fall in its defended area, it immediately issues the command to compare for combat, and all systems and personnel in the defended area are placed in the highest alert status.

The command center uses the target information provided by the radars for fire-power allocation, and first commands the high-altitude interceptors to go into action. When the high-altitude interceptor units receive the order, they immediately make launch preparations and carry out bearing determinations so that the interceptor's flight trajectory passes through the predetermined intercept point.

When the launch command is received, the high-altitude interceptors are immediately launched. Their flight control systems (including guidance systems and attitude stabilization systems) direct them toward the intercept point. The correction commands for the interceptor's trajectory are continuously issued during its flight on the basis of the real position and speed of flight of the target so that the interceptor will intercept it. When the target enters the lethal radius of the interceptor warhead it detonates, destroying the target.

The command and control system analyze and evaluate the results of the high-altitude intercept. If some targets slip through without being destroyed, they will continue toward the defended area, so that the tracking radars may not relax their tracking activity; when the targets enter the atmosphere (generally defined as an altitude of about 80 km), the target tracking radars again carry out tracking and recognition of the targets. Because light chaff such as foil is burned up and falls behind the warhead in the atmosphere (and thus is only usable outside the atmosphere), the opportunity for recognition is good. If a small number of heavy decoys survive, they too will fall behind the warhead as a result of air resistance; thus the target recognition radars can recognize the various targets entering the atmosphere. On the basis of the direction of approach of the targets, the command and control center again allocates fire-power and orders the launch of the low-altitude interceptors. The ground-based guidance system guides the antiballistic missiles toward their targets according to a specific pattern. This is a simplified description of the interception process.

The antiballistic missile target intercept process is shown in Fig. 3.1.

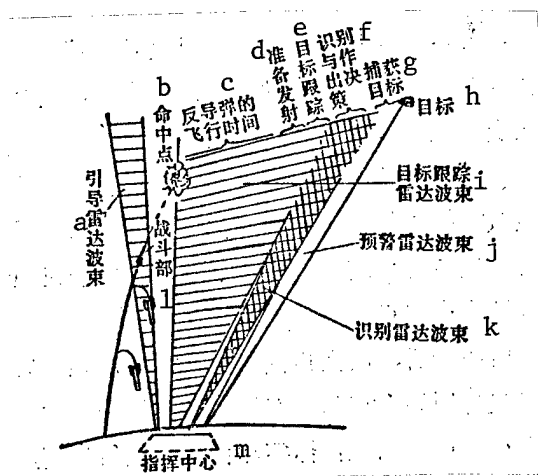

Key:

- a. Guidance radar beam
- b. Intercept point
- c. Time during which antiballistic missile is in flight
- d. Launch preparation period
- e. Tracking period
- f. Recognition and decision period
- g. Lock-on to target
- h. Target
- i. Target tracking radar beam
- j. Warning radar beam
- k. Recognition radar beam
- l. Warhead
- m. Command center

Fig. 3.1. Antiballistic missile intercept process

Time Allocation of Engagement Process

Now, using an ICBM with a 10,000-km flight path as an example, we describe the process by which the antiballistic missile intercepts the target.

The entire flight of the ICBM lasts about 33 minutes, the antiballistic missile intercept process and its timing are as follows.

1. 26 minutes [from ground impact]. The warning system detects the targets and provides 26 minutes warning time (from detection of the target to ground impact); the antiballistic missile units enter the highest alert status.
2. 17-23 minutes. The target tracking radar tracks the targets, calculates their trajectories and estimates the intercept points and ground impact points.
3. 7 minutes. The target recognition system carries out target recognition, distinguishes real and false targets, calculates the target trajectories and expected intercept points (the real intercept point is difficult to determine, and an intercept point can only be calculated on the basis of radar measurements: this calculated value is called the expected intercept point). At this point the target distance (from the center of the defended area to the target) is about 3,000 km.
4. 3 minutes. Launch preparation. The high-altitude interceptors receive the expected intercept point data and carry out azimuthal sighting; on order from the command and control center the combat units launch the high-altitude interceptors. At this point the distance to the target is about 1300 km.
5. 90 seconds. Interception of targets. The ground-based guidance system guides the high-altitude interceptors to the targets. At this point the distance to the targets is about 700 km.

6. 60 seconds. The high-altitude interceptor's warheads explode, destroying the targets. At this point the distance to the targets is about 450 km.

7. 30 seconds. Target recognition. The antiballistic missile system determines the results of the high-altitude intercept, and if all of the targets have been destroyed it prepares for the next engagement. If targets still have not been destroyed, the target recognition system uses atmospheric filtering and other methods to recognize targets which have passed through into the atmosphere, separating warheads from decoys and chaff and tracking the warheads. It calculates the target trajectories and preliminary intercept points and the low-altitude interceptors are readied for launch. At this point the distance to the targets is about 200 km.

8. 20 seconds. Second intercept. At the command from the command and control center, the low-altitude interceptors are launched. The ground-based guidance system guides them to the targets. At this point the distance to the targets is about 100 km.

9. 13 seconds. Destruction of targets. When the targets enter the lethal radius of the low-altitude interceptors, the warheads explode and destroy the targets. At this point the distance to the targets is about 50 km and the targets are at an altitude of 15-20 km.

Six minutes, and 6.5 Seconds

Below we use the US Safeguard system's high-altitude Spartan interceptor and low-altitude Sprint interceptor to give a simple account of the antiballistic missile engagement process.

First we consider the 6-minute flight of the Spartan.

Before launch, the high-altitude Spartan interceptor is stored in a reinforced concrete silo 2.7 meters square and 21.9 meters deep.

Warning satellites are monitoring enemy missile launches abroad; if they detect the launch of a missile they immediately issue a warning and all components of the antiballistic missile system make combat preparations. The long-range tracking radars detect the target at a distance of about 4300 km and furnish 10 minutes' warning. When the target is 3360 km distant (8 minutes before impact) the command to launch the ABM is issued and the Spartan's engine is ignited in the silo. When the one-dimensional thrust exceeds 204 tons the Spartan is launched vertically from the silo, departs from the surface of the earth and begins a programmed turn. When it is 1280 km (2 minutes) from the target, the target tracking radars (site radars) begin to track the target. When the Spartan has been in flight for about 4-5 seconds, the first stage is jettisoned and the main engine begins operation. After 60-65 seconds the Spartan completes the planned turn and has acquired the necessary speed (about 2.2 km/sec). At this time the main rocket engine is shut off and the second stage separates; the Spartan is in free flight outside the atmosphere. The third stage motor is turned on and off in response to the position and velocity of the target so that the ABM maneuvers in flight and moves toward the target.

If the target enters the lethal radius of the Spartan, the ground-based control system issues the order and the warhead detonates, destroying the target with powerful X-rays. The Spartan's intercept altitude is approximately 650 km and the time approximately 90 seconds before the ground impact time.

The entire engagement time for the Spartan is about 6 minutes; the engagement process is shown in Fig. 3.2.

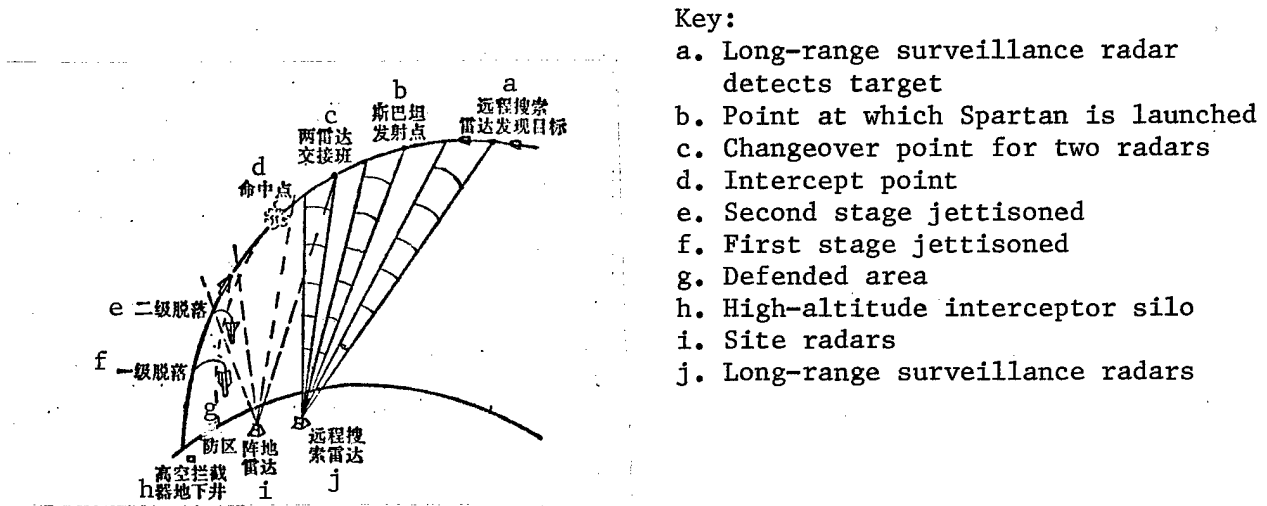

Fig.3.2. The Spartan engagement process

Now let us consider the 6.5-second flight of the low-altitude Sprint.

Before launch, the Sprint is stored in an underground silo. When the target is approximately 100 km from the defended area (20 seconds to impact) the command to launch the Sprint is issued and a gas generator immediately ignites. The high-pressure gas ejects the Sprint from the silo, after which the booster rockets ignite. After about 2 seconds of flight the first stage booster is jettisoned and the main rocket engine ignites. On the basis of the ballistic characteristics of the target and Sprint determined by the radar, the computer formulates commands for corrections in the Sprint's trajectory. When the target enters the Sprint's lethal area (at which point the target is at an altitude of about 52 km and the time to impact is 13.5 seconds), a command is issued from the ground and the warhead explodes, destroying the target.

The entire interception flight of the Sprint lasts approximately 6.5 seconds.

Fig. 3.3 shows the engagement process for the Sprint

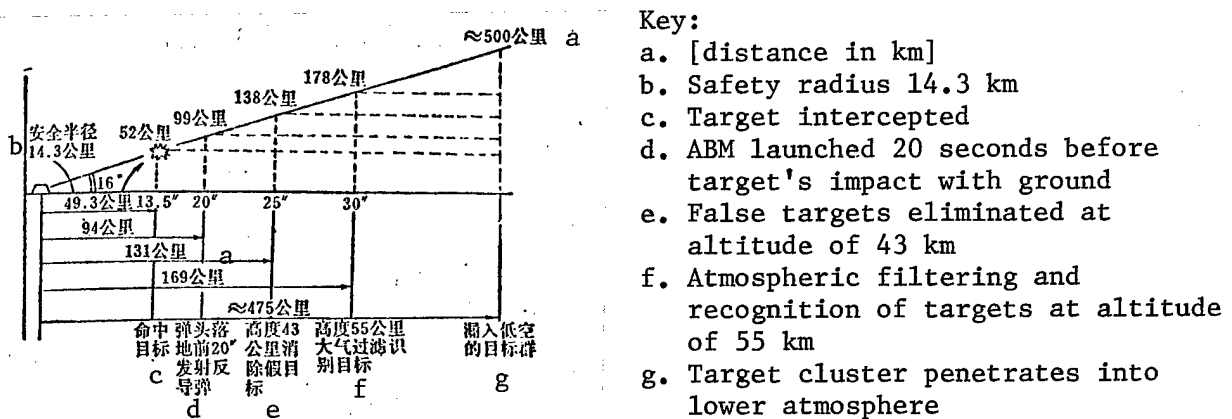

Fig. 3.3. Engagement process for the Sprint

Chapter 4. Guidance Principles

An ABM must use the optimal path in order to intercept an incoming target in space.

In general, it is harder for a weapon (e.g. a rifle) to attack a moving target than a fixed one. Because of the high speed of incoming targets, i.e. warheads (the speed of an ICBM is about 7km/sec, about 2 times the speed of sound), and the short interception time (the entire intercept process lasts from several seconds to several minutes), it is much more difficult to intercept a high-speed warhead than a target flying at slow speed.

Everything is dual in nature. Intercepting a fast-moving warhead has its difficult aspect, but also its favorable side. The latter is the fact that the flight of the warhead follows a specific pattern (the ballistic trajectory). This path can be calculated with great precision using information obtained by radars such as target range, bearing, elevation angle and rate of change of distance (speed).

If the favorable conditions are thoroughly utilized, the optimal intercept method can be determined and a good intercept trajectory chosen.

The Intercept Trajectory

There is a wide variety of ABM intercept paths, but the trajectory of a warhead without the ability to maneuver (i.e. without motive power and control systems) is determinate, so that the intercept path is not chosen at random, but generally belongs to one of the following two types:

1. head-on, in which the ABM intercept the target head-on, as shown in Fig. 4.1;
2. rear attack, in which the target is intercepted from the rear, as shown in Fig. 4.2.

Fig. 4.1. Head-on intercept

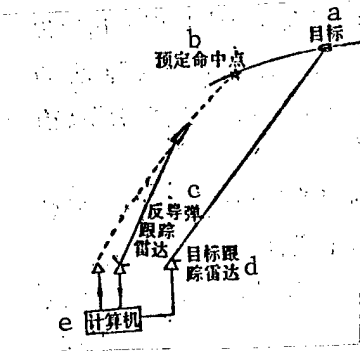

Key:

- a. Target
- b. Designated intercept point
- c. ABM tracking radar
- d. Target tracking radar
- e. Computer

Fig. 4.2. Rear intercept

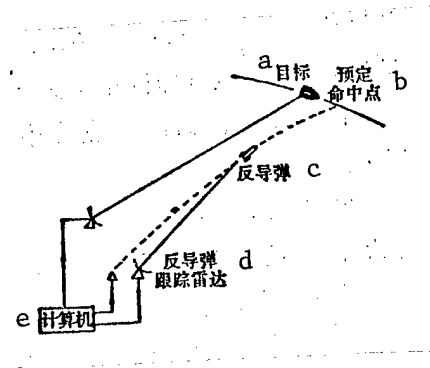

Key:

- a. Target
- b. Designated intercept point
- c. ABM
- d. ABM tracking radar
- e. Computer

Head-on attack is most commonly used.

How is the head-on intercept path determined?

The reasons for choosing this path are that it takes less time, saves energy (uses less propellant) and allows an effective target kill. But how is it carried out in practice?

The target tracking radar and the ground-based guidance radar measure the ballistic data for the target and the missile respectively and use mathematical methods to compute the target's trajectory and the intercept point (i.e. the point at which the target and the missile will meet); if the missile accurately flies its course to the intercept point it will meet the target.

It may be asked why, since a rifle can be aimed at either a fixed or a moving target on the battlefield, and the ABM is aimed at the intercept point rather than the target itself.

If you watch an experienced hunter hunting rabbits, the riddle is explained. Experienced hunters always aim at a point ahead of the rabbit because a certain amount of time elapses between aiming and firing, and during this time the rabbit will already have moved forward a certain amount, with the result that the bullet so aimed will strike it. Otherwise the shot would go behind the rabbit.

The ABM intercept process is similar to a hunter's shooting at a rabbit.

Because the target and the missile are both flying at high speed, if a line between the target and the ABM were taken as the intercept path, the intercept

would be unsuccessful and the target would not be hit: by the time the missile had flown to the position which the target had occupied at a certain time, the target would already have moved to another position at a speed of about 7 km/sec (in the case of an ICBM). Accordingly, the ABM must be aimed at the intercept point. This is the way in which selection of an ABM intercept path is similar to a hunter's shooting at a rabbit.

The ABM's trajectory toward the intercept point (which is not a straight line connecting the two) is called the reference path. When we fall into formation, whether or not our position and direction in the formation is correct generally depends on the position of the parade guide and the direction in which he is facing. If the position and direction of an ABM at a given moment are incorrect, what sort of a "guide" does it have? The guide is the "reference path." The reference path is determined from the target's motion characteristics and the flight capabilities of the ABM's motor (see Fig. 4.3). With the reference path it is possible to determine the correct position and direction of flight of the ABM (Fig. 4.3).

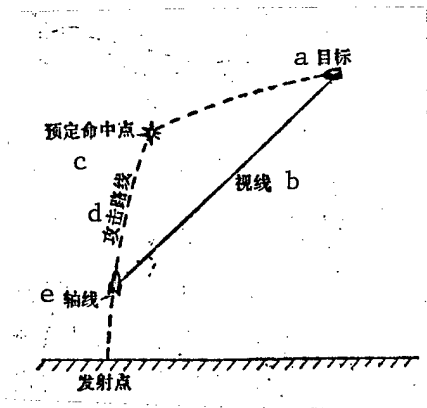

Key:

- a. Target
- b. Line of sight
- c. Intercept point
- d. Attack trajectory axial line
- e. Launch point

Fig. 4.3. Intercept path

The pattern which controls the ABM's reference path is called the "guidance pattern." Thus we can say that the guidance pattern actually determines how to compute the reference path, and the problem is to find an optimal guidance pattern which will bring the ABM successfully to its target. Some attack trajectories are shown in Fig. 4.4.

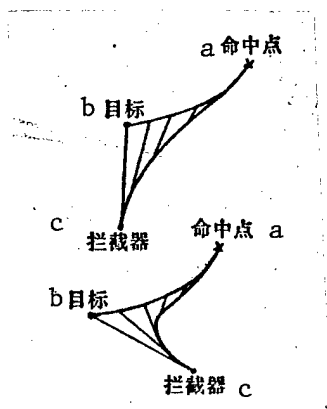

Key:

- a. Intercept point
- b. Target
- c. Interceptor missile

Fig. 4.4. Attack trajectories

In actual flight, the ABM may be subject to interference from various factors (produced by measurement error, errors in missile manufacture and the like) which make its actual flight path deviate from the reference path so that it does not fly towards the intercept point and is unable to intercept the target. This is one factor which would prevent destruction of an incoming target.

Another factor which would prevent destruction of the target would be rather large errors in the target's trajectory as measured by the radars: if these erroneous data were used to calculate the designated intercept point, the result would be "drift" of the point (i.e. it would depart from the real intercept point) so that the target would not be destroyed.

Therefore, if the designated intercept point drifts, i.e. slowly shifts from the real intercept point, the ground-based guidance system sends out a command for the ABM to return to the reference path. In this way the missile will be made to fly along the reference path at high speed and destroy the target (see Fig. 4.5.).

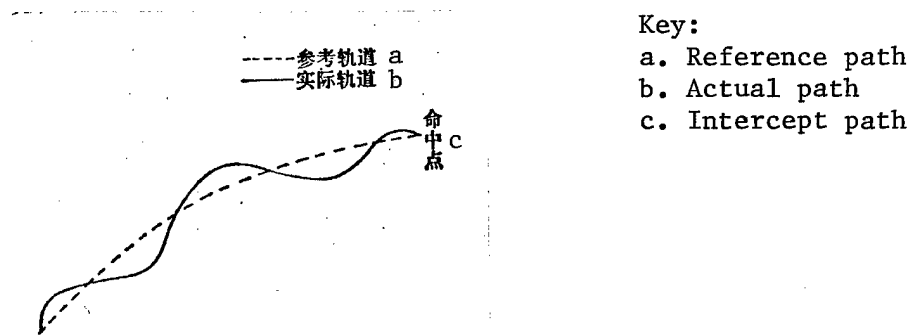

Fig. 4.5. Deviation from path

The system which directs the missile to follow the reference path is the ABM guidance system, part of the ABM flight control system. The guidance system controls the missile's flight in accordance with the guidance program: it continuously issues control instructions which cause the missile to fly towards the designated intercept point in accordance with the guidance program and destroy the incoming target.

More specifically, the basic task of the guidance system is to determine the missile's position and velocity and produce control commands to alter its path in accordance with the trajectory of the target, so that it will destroy the target.

The guidance system consists of a variety of devices which assure that the missile will be guided to its target. The principal ones are as follows.

1. Measuring equipment, used to measure the missile's actual flight path, including determination of its speed and attitude.
2. Missile onboard computer, which continuously calculates the divergence of the missile's actual flight path from the reference path and formulates control

commands so that the control devices perform the proper operations. The main requirements regarding the onboard computer are that it be small and light, consume little power, be reliable and have good capabilities. The computer can receive control instructions directly from the ground-based guidance system and convert them into instructions which keep the missile on the required path. Particularly since the advent of the microprocessor, computers have come into extensive use in flight control systems and have become one of their most important components.

3. The onboard receivers, which receive the target trajectory data measured by the radars and the various control commands from the ground.

4. The control equipment, which changes the positions of the actuating devices on the basis of commands from the computer. The rotation of actuating equipment (such as the exhaust nozzles, swiveling engine and the like) can adjust or control the magnitude and direction of engine thrust and thus change the velocity and direction of the missile so that it follows the required path or returns to the reference path.

While the missile is in flight the control system must determine the required magnitude and direction of the thrust in accordance with commands from the control system; the magnitude and direction of the thrust are controlled in terms of the angular error sensed by the autopilot equipment. Outside the atmosphere the small nozzles or swiveled engine are moved in response to the size of the angular error signals so that the missile attains the proper attitude (Figs. 4.6, 4.7).

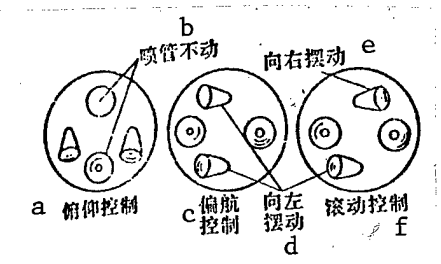

Fig. 4.6. Use of movable exhaust nozzles to control motion of the missile

- Key:
- a. Pitch control
 - b. Nozzles not moved
 - c. Yaw control
 - d. Moved toward left
 - e. Turned toward right
 - f. Roll control

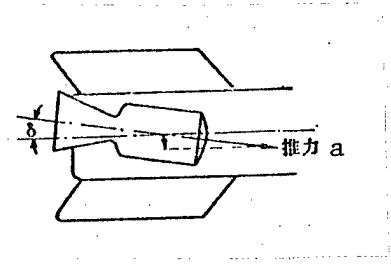

Fig. 4.7. Swiveled engine

- Key:
- a. Thrust

Thus the missile's flight control system includes not only the guidance system but the flight stabilization system (attitude stabilization system). The flight stabilization system must assure that the missile has good stability, must maintain stable flight (without rolling or pitching) under any type of interference and must respond rapidly to all control signals by using the attitude control system to correct the attitude of the missile, so that it follows its path with the proper attitude until it destroys the target.

Guidance Principles

Before we introduce ABM guidance principles let us consider a tragedy that occurred when a passenger aircraft lost its way.

On 20 April, 1978, Flight 902 left Paris for Seoul carrying 97 passengers. The distance was 13,500 km.

Initially everything went well. En route, in the vicinity of Canada's warning station at Alaité [phonetic] the aircraft inexplicably made a turn far off its correct course, towards the Kola peninsula in the Soviet Union (see map [not reproduced]). At this time it was slightly over 4 hours out of Paris.

The aircraft flew on for 2 hours, entering Soviet airspace at Murmansk.

At this time the Soviet Air Force Command gave the order: "Attention: attacking aircraft."

As soon as the order was given, six supersonic Su-15 fighters immediately took off and intercepted the airliner.

The Air Force Command gave the order: "Fire."

One of the fighters launched two air-to-air missiles at the aircraft. One of them struck it, tearing off a piece of the wing tip, while fragments of the warhead passed through the center of the fuselage, killing 2 persons and injuring 13.

The stricken aircraft rapidly descended, looking for a place to land.

When the Soviet pilot lost sight of the target (the stricken aircraft) he reported to the command that it had been shot down.

It was already dark. The aircraft, with its brave passengers, made a dangerous landing on a frozen lake in the dark.

This is a simplified account of how a Boeing 707-320C lost its bearings, strayed over Soviet airspace and was nearly shot down by the Soviet Air Force.

How could this aircraft have lost its bearings? One reason was that the guidance system malfunctioned and was unable to indicate its correct course.

If it had been an unmanned aircraft or a missile whose guidance system went out of commission, who knows what might have happened?

What kind of guidance does an antiballistic missile use?

The guidance which an antiballistic missile uses to intercept its target generally is radio command guidance. In command guidance, the commands which control the flight of the missile are issued by the ground-based guidance system and transmitted to the missile by radio.

Command guidance requires that the guidance system be extremely precise, that it have high immunity to interference and that the onboard equipment be reliable. The command guidance system consists of the ground-based guidance system and the onboard equipment. The commands are transmitted by the ground-based guidance radar. Fig. 4.8. is a diagram of a common type of command guidance system.

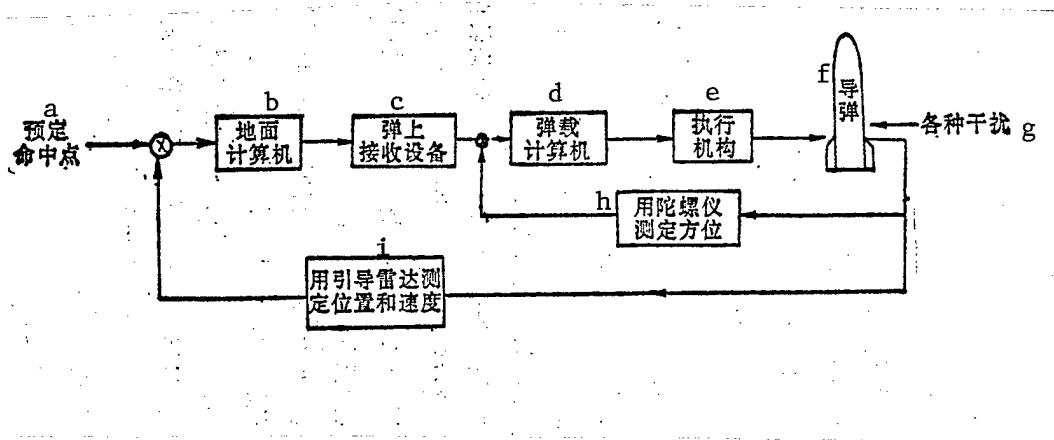

Fig. 4.8. Operation of command guidance system

Key:

- | | |
|-------------------------------|---|
| a. Designated intercept point | f. Missile |
| b. Ground-based computer | g. Interference |
| c. Onboard receiver | h. Position determined by gyroscope |
| d. Onboard computer | i. Position and velocity determined by guidance radar |
| e. Actuating devices | |

When the missile is subjected to interference, the ground-based guidance system uses radar measurement data to calculate the changes in the missile's trajectory data (position and speed), then by computation and comparison it forms control commands for the missile and transmits them to it, enabling it to intercept its target.

The main components used in radio command guidance are as follows.

1. The ground-based guidance radar, which can accurately determine the position and velocity of the missile and relay this information quickly to the computer.

2. The ground-based computer system, which consists of one or more large-sized computers and which can make rapid and precise calculations of target or missile ballistic data and quickly compare them with the data for the designated intercept point, form control commands and transmit them to the missile's guidance system in coded form.

3. The automatic pilot, which receives control commands from the ground-based guidance system, compares them with the data from the onboard position sensor, operates the actuating devices to control the missile's thrust and direction, and thus corrects the missile's course.

Command guidance also includes the following types: radio command guidance, beam guidance and guidance by two radar tracking stations.

Now we discuss the characteristics and basic principles of command guidance as exemplified by radio command guidance (also called radio line-of-sight guidance).

When radio command guidance is used, the line-of-sight axis must point in the required direction, i.e. toward the designated intercept point. Because the missile and the target are moving, only if the line-of-sight axis continuously points toward the expected intercept point can the target be intercepted (see Fig. 4.3). Obviously, when the missile and the target meet, the line-of-sight axis will be pointing toward the target.

In simplified form the principles of command guidance are as follows.

After the missile is launched, the ground-based guidance radars lock on to it (i.e. the missile is in the radar beam). The radar measurement data are used to calculate the trajectories of the target and the missile, and control commands are formulated by the ground-based guidance station (or the onboard computer) and relayed in code to the missile's control system in order to keep it in the beam. The missile's deviation from the "line of sight" (angular deviation or distance from the line-of-sight) determines the system's error signal (Fig. 4.9). Accordingly, in this type of guidance, the guidance radar does not track the real position of the missile but tries to establish a "line of sight," and when the missile is tracked by the radar it attempts to determine the missile's deviation from the radar line-of-sight, enabling it to formulate control commands to guide the missile to its target.

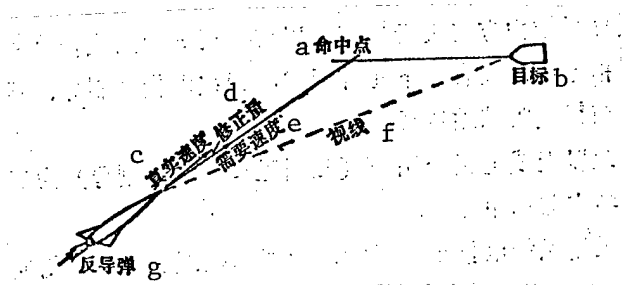

- Key:
- a. Intercept point
 - b. Target
 - c. Real velocity
 - d. Correction amount
 - e. Required velocity
 - f. Line of sight
 - g. Antiballistic missile

Fig. 4.9. Command guidance

Radio command guidance can be used throughout the missile flight stage, or only in the final stage of flight; or it can be used first during flight, followed by automatic homing guidance. If both types of guidance are used, the result is a compound guidance system. Combined guidance generally results in greatly increased accuracy.

In a command guidance system, the missile's flight pattern generally is decided upon by the ground-based guidance system (it can, of course, also be decided in the air or on shipboard).

Chapter 5. Design and Characteristics of Antiballistic Missiles

Conventional weapons such as rifles and guns can easily be seen, while interceptor missiles such as ABM's rarely on display. What is an antiballistic missile like? What are its characteristics?

During spring festival, young people enjoy firing off skyrockets. On the night of the festival we see many rockets launched into the sky, trailing a multi-colored tail of fire behind them. Although these skyrockets are toys, they can help us to understand the design of antiballistic missiles.

The antiballistic missile is a type of ballistic missile. In crude terms, it resembles a skyrocket in that it is a solid-fueled rocket.

General Design

The antiballistic missile consists of the warhead, propulsion system, flight control system and missile body (see Fig. 5.1).

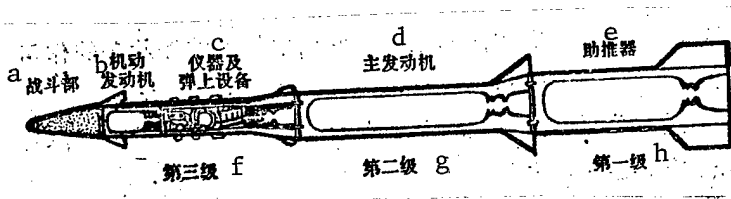

Key:

- a. Warhead
- b. Maneuvering engine
- c. Instrumentation and onboard equipment
- d. Main engine
- e. Booster
- f. Third stage
- g. Second stage
- h. First stage

Fig. 5.1. Design of antiballistic missile

The capabilities of the various components of the antiballistic missile can be simply described as follows: without the propulsion section the missile could not fly; without the flight control system it could not fly on a path specified by people or proceed to the point at which it intercepts the target; without the warhead, even if it met the target it could not destroy it. Are these components enough? No. Also required is the component which combines all of these parts into a whole, namely the missile body.

The warhead is similar to a grenade or bomb and is the part of the ABM which destroys the target. The main part task of the ABM is to carry the warhead to the vicinity of the target and use it to destroy the target.

A grenade generally consists of the explosive, a fuse and a safety device (on a handle-type grenade the handle cover is the safety device).

The warhead of an antiballistic missile also consists of the explosive, fuse and safety device.

The explosive is the main part of the warhead: it stores large amounts of energy which it uses to destroy the target.

The fuse causes the warhead to detonate. At the moment when the warhead will have the greatest effectiveness the fuse immediately "ignites" the charge and causes it to explode.

The safety device is what its name indicates: it automatically releases when the missile reaches the intercept area so that the fuse is ready to act; before the missile is launched it assures that the warhead cannot explode, but when the missile misses its target it can also make the missile self-destruct. Thus it is a device which not only can preserve the safety of our side but also can ready the warhead. It acts similarly to the safety cover of a grenade.

The warhead can be divided into the nuclear warheads and nonnuclear warheads (i.e. conventional warheads). Most ABM's use nuclear warheads.

In the past there have been accidents in which a hole was made in a properly functioning aircraft during takeoff, damaging it.

If the airfield was not under attack, how could the aircraft have been damaged? It turned out that when the airplane was taking off, a small sparrow flew head-on into it, causing the accident. The first collision of a bird with a plane occurred in 1912 when the famous cross-country flier Luodejeer [phonetic] was flying over California and a seagull collided with his aircraft, causing it to crash and killing him.

But how can a small sparrow damage an airplane? The secret is their relative velocity.

Consider a bird weighing 100 grams. If it collides with an airplane flying at a speed of 80 km/hr, their relative speeds produce a collision force of about 30 kilograms, equivalent to about 300 times the weight of the bird--a considerable force.

When a missile intercepts a target head-on, there is an extremely large relative velocity between the two (over 8 km/sec), so that pellets or shrapnel from the explosion of a conventional warhead would have a relatively great lethal power. If they struck the warhead moving at high speed, they would seriously damage the charge. If they entered the charge they could disable the fuse or cause the charge to explode early or damage its casing, which would destroy it or make it burn up when it reentered the dense atmosphere.

The propulsion system is also a motive system, the thrust which it produces pushes the antiballistic missile toward the target.

Antiballistic missiles generally use solid propellant. Why? The skyrocket uses a solid propellant, which is the "fuel" burned in its engine (see Fig. 5.2). Figs. 5.2 and 5.3 show solid fuel rocket engines. There are various types of solid propellants; the US Sprint ABM uses a modified double base propellant in its first and second stages.

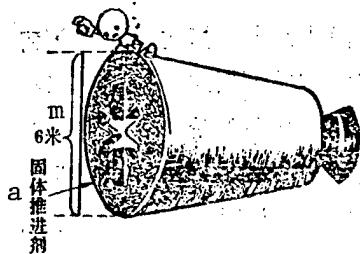

Key:
a. Solid propellant

Fig. 5.2. Large solid-fueled rocket engine with cast compound propellant

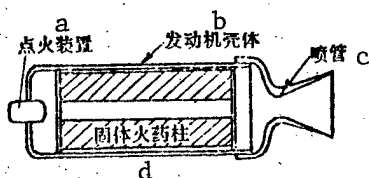

Key:
a. Igniter
b. Engine casting
c. Nozzle
d. Solid propellant column

Fig. 5.3. Design of solid-propellant engine

The operating principles of a solid-fueled rocket engine are simpler than those of a liquid-fueled engine. To start the engine, an electrical igniter is used to produce a flame which ignites the propellant column in the combustion chamber; when the propellant burns, it produces high-temperature, high-pressure combustion gases which expand in the nozzle of the engine and are ejected at high speed, producing thrust.

The solid-fueled engine has many advantages over the liquid-fueled engine, such as a simpler propulsion system which does not require a complicated propellant feed system, simpler, more reliable engine design, higher fuel density, advance loading of the solid fuel into the engine, resulting in a short combat preparation period, and decreased logistical and maintenance work. These advantages mandate the use of solid-fueled engines.

The flight control system guarantees that the missile will not roll or pitch uncontrollably during flight and keeps it flying on the required path (trajectory) toward the target. It functions as we do when riding a bicycle, holding the handlebars in our hands and keeping the bicycle moving in a specific direction. In figurative terms, the flight control system is the "pilot." The system includes sections for control of the movement of the center of mass and control of movement around the center of mass. If the missile cannot maintain a specified direction in space but turns this way and that, there is no control, and it will not even be able to maintain itself in flight, but will either tumble uncontrollably and crash or break up in midair. Accordingly, the missile must have attitude control. The system which exercises this control is called the attitude stabilization system (or attitude control system). In other words, the attitude stabilization system's function is to control the

direction of thrust so that the missile turns about its center of mass and flies stably. The stabilization system functions by adjusting the magnitude and direction of the thrust of nozzles or a swiveled engine. The nozzles or swiveled engine are moveable like small "hands," and can control the missile and keep it in the prescribed attitude (orientation in space) so that it flies steadily toward the target.

The system which controls the motion of the missile's center of mass is called the guidance system. This system is used to control the movement of the missile's center of mass and to insure that the missile can intercept the target, i.e. it directs the missile toward the target according to the guidance program. For this purpose it is necessary to eliminate deviations from the reference path and keep the position and speed of the missile on the reference path. The way in which this is carried out is by taking continuous measurements of the ballistic characteristics (position and velocity) of the target and the missile during flight and using a computer to compare these characteristics and formulate control commands for guidance, so as to control the motion of the missile's center of mass until it intercepts the target.

The missile body combines all of the components and systems into a single unit, the antiballistic missile, so that it can carry out its task of destroying incoming targets. Fig. 5.1 shows the designs of a three-stage antiballistic missile. The missile's skin generally is made of aluminum alloy with a steel reinforcing framework.

Characteristics of Antiballistic Missiles

If the antiballistic missile is used specifically against offensive warheads (MRBM's, LRBM's and ICBM's, launched from the ground surface or from submarines), what characteristics must it have? Before specifying its characteristics, we must have a general understanding of the characteristics of offensive ballistic missiles.

An intercontinental ballistic missile flies at high speed, up to 25,000 km/hr (more than 700 times as fast as a bicycle traveling 15 km/hr; it would take a bicycle nearly half an hour to cover the distance which an ICBM covers in a second), and the entire flight path is covered in a short time (about 30 seconds). If an ICBM with a range of 10,000 km is detected and acquired by radar at 4,000 km, only 10 minutes will elapse before ground impact. It is clearly difficult to shoot down the warhead in this short a time.

The main difficulty of target interception by means of an ABM is the shortness of the warning time (a maximum of only about 25 minutes for an ICBM). In order to resolve this contradiction, special demands were imposed on the ABM. For example, if tracking of an ICBM warhead begins at a distance of 2,500 km, the period between the beginning of tracking and ground impact is only about 6 minutes. Accordingly, speed has become the key to ICBM interception. The ABM must accelerate rapidly and fly rapidly.

It must rapidly meet the target head-on. If it is slow in doing so it may itself be "hit" and destroyed by the incoming missile.

Quickness requires fast ignition of the missile's engine, rapid burning of the propellant, and rapid ejection of the combustion gases. To use rocketry terminology, the solid-fuel engine (or booster) must have high thrust, high specific impulse, high combustion speed and a high mass ratio.

Only in this way is it possible to assure that the missile can be accelerated to a speed of several km/sec in a few seconds, which means an acceleration of several tens to more than a hundred times that of gravity ($g = 9.8 \text{ m/sec}^2$), equivalent to several tens of times or more than a hundred times the weight of the missile. Only in this way can the missile meet the incoming target at top speed.

The missile must be readily maneuverable. It must be able to turn rapidly toward the target. This requires that the magnitude and direction of engine thrust be variable so that the missile will be easy to operate and can be controlled flexibly. Accordingly, the missile must be equipped with a maneuverable engine which allows maneuver in flight.

It must be resistant to high temperatures. When the missile (particularly a low-altitude interceptor) is flying in the atmosphere, the friction between it and the air may raise its skin temperature to more than 1000° . If the missile is not resistant to high temperatures, it may burn up before it completes its mission of intercepting the target. As a result, high-temperature paints or high-temperature structural materials are used for the body of the missile.

In general, ABM engines must be solid-fueled, have high thrust, high acceleration and a short startup time (fast ignition), be easy to start, require little preparation time, and be easy to maintain and reliable.

When an antiballistic missile possesses these characteristics it has some of what it needs to "catch" the target; but these characteristics are not sufficient. How is the missile made to be maneuverable in flight so that it can intercept the target?

For maneuverability in flight, the antiballistic missile uses movable rocket nozzles which can vary the magnitude and direction of engine thrust, or exhaust gas control nozzle assemblies or secondary exhaust jets (in which the hot gases coming directly from the combustion chamber can be passed through secondary nozzles and interact with the main gas flow, thus altering the control force (see Figs. 5.4 and 5.5).

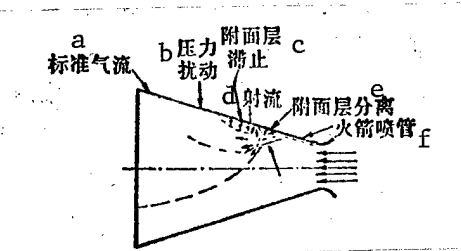
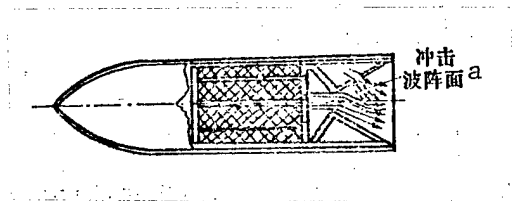

Fig. 5.4 Secondary exhaust nozzle in solid-fueled engine

Fig. 5.5. Secondary nozzle thrust vector control

(Keys for Figs. 5.4 and 5.5 are on the following page).

*Specific impulse is the ratio of the engine thrust to the mass consumption per second; the mass ratio is the ratio of the total mass to mass at burnout; mass consumption per second is the mass of propellant consumed each second.

(Keys for Figs. 5.4 and 5.5 are continued from the previous page).

Fig. 5.4

Key:

a. Shock wave front

Fig. 5.5

Key:

a. Standard gas flow
b. Pressure disturbance
c. Boundary layer stagnation
d. Efflux
e. Surface layer separation
f. Rocket nozzle

Why does the secondary nozzle vector control work?

The surging Yangtze River flows for a thousand li. It is formed by the water from innumerable tributaries. If you were standing at the mouth of the Han River at Wuhan and looking at the Yangtze River, you would see that the turbulent waters of the Yangtze "made way" for the Han River, then slowly swallowed up its waters.

A secondary jet can be said to make use of the dynamic principle involved in this type of "making way." The secondary jet injects a fluid (liquid or gas) into the engine nozzle, just as the Han River flows into the Yangtze. This produces a kind of aerodynamic barrier in the main flow from the engine nozzle (as in the Yangtze River) and there is a positive-pressure area on the nozzle wall in the vicinity of the injection hole, as a result of which the magnitude of the thrust is altered and its direction may be changed. Fig. 5.6 illustrates the secondary injection principle.

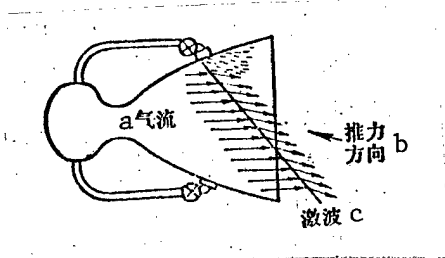

Key:

a. Gas flow
b. Direction of thrust
c. Shock wave

Fig. 5.6. Production of a shock wave to alter jet direction

Use of secondary injection thrust vector control increases the lateral force, which achieves the goal of variable thrust direction and magnitude.

Some Examples of Foreign Antiballistic Missiles

To provide further understanding of antiballistic missiles, we discuss the design and characteristics of some specific foreign models.

1. The Spartan High-Altitude Interceptor

The Spartan is a high-altitude long-range interceptor with an average speed of 2.2 km/sec and an interception altitude of 160-480 km.

The Spartan is a finned three-stage solid-fuel missile. The first stage is the accelerator (booster) and is about 5.4 meters long and 1.1 meters in diameter. The second stage is the main engine, which carries out acceleration and maneuver. Accordingly, the Spartan has some maneuverability and can "catch" its target by using guidance commands. The third stage contains a spherical engine and the nuclear warhead, power source, electric power unit, control instrumentation, automatic pilot, stabilized platform and onboard computer. The Spartan's design and external shape are shown in Fig. 5.7.

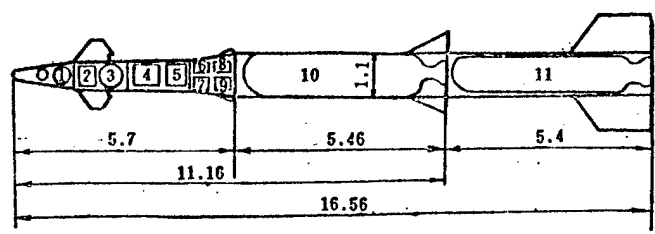

- Key:
1. Warhead section
 2. Gyroscope
 3. Engine
 4. Power source
 5. Electric power unit
 6. Control system
 7. Automatic pilot
 8. Stabilized platform
 9. Computer
 10. Main engine
 11. Booster

图5-7 “斯巴坦”的外形与结构示意图
 1—战斗部；2—舵机；3—发动机；4—能源；5—电源；6—控制系统；
 7—自动驾驶仪；8—稳定平台；9—计算机；
 10—主发动机；11—加速器。

Fig. 5.7. Shape and design of the Spartan

The Spartan carries a several-megaton thermonuclear charge. When the charge explodes at a high altitude, 70 to 80 percent of the energy is released within a tenth of a microsecond in the form of invisible X-rays which destroy the heat-protective layer of the explosive charge so that the material inside is vaporized and the charge is burned up. The Spartan warhead's kill radius is about 8 km.

Although the Spartan has some ability to maneuver and "catch" its target, it is not able to "catch" a high-speed target in a large area of decoys and chaff. Because the incoming warhead is in a group of false targets, the problem is like that of finding a bad man in a crowd of several hundred: it is difficult to distinguish the true from the false quickly. Hence until the problem of distinguishing true from false targets at high altitudes is solved it is difficult for the Spartan to catch the true target. But can it annihilate both true and false targets? The guidance accuracy of the Spartan is limited and the warhead cannot be exploded in a target cluster, in addition to which its lethal capacity is limited, so that the Spartan cannot destroy a group of true and false targets scattered over a "channel" several kilometers wide (see Fig. 5.8).

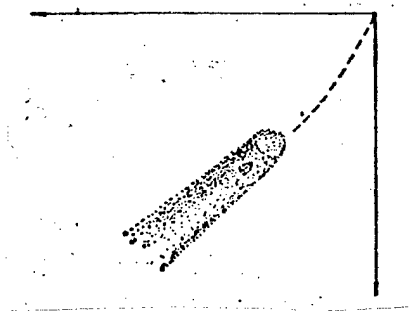

Fig. 5.8. A target cluster

2. The Sprint Low-Altitude Interceptor

The Sprint interceptor has an average velocity of approximately 3.2 km/sec and an acceleration of more than 100 g's.

The Sprint is a two-stage solid-fuel missile of conical shape with a base radius of 1.37 meters and skirts (tail sections) consisting of 9.5-mm-thick aluminum honeycomb. It consists of two conical frustums of different tapers. The outer wall is the shiny circular outer surface, while the inner wall is the extended skirt of the first-stage engine. Between the inner and outer surface of the skirt is installed the first stage engine's thrust control system.

Thrust control consists of liquid secondary injection in the first stage, which gives the missile a certain degree of maneuverability. The second stage uses four small control surfaces at its base. The guidance and stabilization equipment are installed between the second stage engine and the warhead.

After the Sprint reaches maximum velocity, its surface temperature is higher than the temperature inside the engine; accordingly, heat protection measures such as the use of ablative material (silicone phenolics and the like) are used to protect the guidance and stabilization systems.

In order to approach the target head-on and "catch" it, the Sprint uses a rapid-combustion, rather high-energy solid propellant, a modified double-base propellant. After the first stage burns out and is jettisoned, the Sprint uses its basic aerodynamic shape to carry out limited maneuver in order to intercept the target.

Fig. 5.9 illustrates the Sprint.

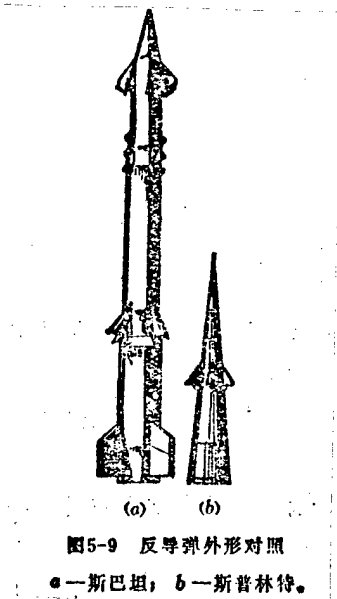

Key:
a. Spartan
b. Sprint

图5-9 反导弹外形对照
a—斯巴坦；b—斯普林特。

Fig. 5.9. Antiballistic missiles

The Sprint is still not a highly maneuverable missile, and its ability to intercept its target is rather poor; this is because it "runs" slowly, its acceleration is rather low, it is not very maneuverable and its guidance precision is not very high.

Chapter 6. The Command and Control Center: The "Brain" of the Antiballistic Missile System

Consider what a disaster chaotic command can produce.

An accident took place at Santa Cruz airport in the Canary Islands. On 27 March 1977, a Sunday, traffic at the airport was extremely heavy. At 1440 GMT a Royal Dutch Airlines Boeing 747 jumbo jet was making its takeoff run.

This aircraft weighed 350 tons, its wingspan was nearly 60 meters, and it was 70 meters long. Propelled by four turbofan engines, it produced an earsplitting roar as it picked up speed along the runway; its speed had already reached 300 km/hr and it was about to take off.

Suddenly, from an intersecting runway, another jumbo passenger jet appeared in front of it. The captain of the Dutch plane suddenly saw the immense aircraft in front of him, but he had no chance to stop or turn. The 300-ton aircraft rushed furiously ahead at 300 km/hr.

In less time than it takes to tell, there was a roar and the Dutch aircraft crashed into the other plane. The fuel from the two aircraft produced a series of explosions and the planes flew apart, with some of the fragments being thrown 400 to 500 meters. The Dutch jet was the first to catch fire. Even the asphalt on the runway was burned by the fierce flames.

The other craft was a US Pan American Airways jet, also a Boeing 747. It had arrived from Los Angeles and had made a brief stop in Santa Cruz.

This was the worst crash in history, leaving 576 persons dead.

The crash was clearly the result of confusion in the airport's traffic control system. This makes clear the size of the responsibility imposed on command and control systems.

Command and control has always been an important part of warfare. The command center within the command and control system has an important role in the antiballistic missile system, equivalent to the function of the brain in the body. It commands and guides the coordination of all parts of the weapon system as it moves flexibly to intercept its target. If the command system malfunctions, the defensive system may be defeated.

The Functions of the Command Center

The command center is the decision-making organ of the antiballistic missile system which must analyze and synthesize all available information, decide how to deal with all incoming targets and report information on the air situation

to the higher-level staff so that the orders to counterattack, to intercept and destroy the targets, can be issued. It is a completely automated system which can centralize and effectively command and allocate all systems, personnel and antiballistic missile weapons so as to make full use of their combat capabilities and destroy all incoming enemy missiles.

The mission of the command center, simply stated, is to provide the state command organs (the brain, or the general staff) with correct, timely information and to exercise command over the work of its subordinate departments (or systems). For example, 1) it keeps aware of developments, including the actions of friendly and enemy missile units; 2) it evaluates attack warnings and the threats posed by incoming targets; 3) it mobilizes ABM units for preparations to repel an attack; 4) it counterattacks against incoming targets, orders the launching of high and low-altitude interceptors and evaluates intercept results; 5) it reorganizes ABM units and commands their preparations to repel attacks or to make a second counterattack; 6) it issues the order to disengage.

In order to make rapid decisions, the command center must automatically synthesize information on the air situation and target information; it must automatically process target information and carry out recognition; it must automatically process data on ABM combat preparations and combat actions; it must select intercept paths and order the launching of the missiles; and it must display ABM and target information on a screen or indicator.

The computer is the principal equipment for decision-making. The command center's computers have the task of making correct decisions on the basis of information on incoming targets and friendly ABM's, and using large screen displays and other display equipment to provide the commander with immediately-intelligible information and optimal combat plans. Accordingly the computer is the "thinking" organ of the command and control center; some call this "thinking" machine an "electronic brain." All commands issued by the command center must be formulated by a high-speed computer before they are issued; in order to increase reliability, multicomputer arrays, fault-tolerant technologies and diagnostic and self-testing equipment are used. If the computer makes an error, a disaster may result. In the United States, computer malfunctions resulted in an erroneous nuclear alert, causing needless alarm.

This incident happened one morning in early winter, on 9 November, when the compiler program in a computer in the NORAD building in Colorado malfunctioned so that the (false) signal for "Enemy Air Attack" appeared on the warning system radar, with the result that the command center also issued an alert and the aircraft at many air bases took off to intercept the attack, although they encountered nothing aloft. This computer malfunction resulted in an alert lasting 6 minutes.

The command center generally includes the combat, reconnaissance, communications, and meteorological sections.

The combat system is equipped with several computers and information display devices. The information display devices include large fluorescent screens, automated work display terminals and large-screen displays (such as the commonly

used 10-square-foot screens). The status of enemy air activity, the state of ABM readiness and information on other aspects of system operation are all continuously transmitted to the combat system. Various combat orders, intelligence information and combat results can be displayed in easily-grasped fashion on the combat system's display equipment so that the command personnel can manage the entire situation and exercise command over the counterattack against incoming targets in smooth fashion. To summarize, the entire process from detection of targets to their destruction can be displayed on the command center's display equipment. The personnel on duty in the command center can see these displayed results from their work stations. The diagrams, lines and figures on the screen are all under computer control.

Weather forecasting aims at providing the command center with weather predictions. It can provide information on clouds, the ionosphere, temperature, snow, rain, fog and the like as well as earth phenomena. Weather satellites, weather radars, weather balloons and other sensing methods can be used to obtain meteorological information.

The communications system is the "nerve-center" which links together all components. Since antiquity, communications and liaison have been a concern to which attention must be devoted in every aspect of combat. Modern combat requires that the command system have uninterrupted, reliable, error-free communications and that all systems be coordinated. There are many lessons of success or failure in history; the Pearl Harbor attack and the Mideast Crisis are examples.

One day during World War II, a radar system belonging to the US forces guarding the northern coast of Oahu picked up incoming Japanese aircraft, but because of communications system factors (the slowness of the military communications equipment), this important warning information could not be relayed to the air defense headquarters before the enemy planes attacked, so that the US fleet came under Japanese attack and was seriously damaged: this was the famous Pearl Harbor attack. But during the 1973 Mideast crisis, when the US national military command center issued an alert to all headquarters via its Worldwide Military Command and Control System, all service staffs and special forces staffs received this order within 3 minutes.

In the case of an antiballistic missile system, erroneous decisions or plans made by the command center, blockages or malfunctions in the command system or lack of coordination between systems can cause the defense to come under attack or may even result in the destruction of the defensive system. Accordingly, assuring reliable, highly efficient operation of the automated command center is extremely important.

In an ICBM attack the defense system will have only 10 to 20 minutes' warning, while in the case of an MRBM's the warning time will be even shorter (several minutes to 10-odd minutes; see Table 3 in appendix). Time is of the essence in attacking the targets. Using telegraph or telephone to command the counter-attack amounts to forfeiting the initiative and inviting defeat, and there is a danger that the defensive system will be destroyed. Especially since the missiles must be guided to the target intercept with extremely high precision, the command system must be extremely fast-acting, precise, reliable and secure. And what is used to operate this automated system? The electronic "brain" which we mentioned above, a high-speed computer, is the best "operator."

It should be made clear that current command and control system still have weak points, such as large antenna arrays, which are vulnerable to nuclear weapons effects which could result in the command and control system's losing its source of information or its contact with other systems, thus paralyzing or partially paralyzing it. Use of a small-sized communications net could eliminate this defect; a small communications network is easy and flexible to use and could decrease the danger of damage by nuclear weapons.

Functions of Electronic Computers

The command and control system must have a complete computer network. This network must have a large modern computer, which may be a hybrid parallel processor structure. This large computer may be connected to small processors, remote terminals and display devices, forming an effective command and control system.

Fast computers are computation, data-processing or automatic operating devices which can perform computations in accordance with a preexisting program, process conditions arising during a process and automatically organize a logical procedure, or apply an automatic control procedure to the ABM system, such as issuing a command, evaluating results or the like.

The computer must make decisions and allocate the components of the ABM system to deal with a target cluster, compute missile intercept trajectories and formulate missile control instructions to guide the missile to its target.

The computer is a device with many capabilities. In addition to carrying out all information processing and automatic control during the intercept process, it also performs a number of other tasks.

1. The computer controls the radar beam, making several successive observations of incoming targets, analyzing and determining the target type (missile, meteor, satellite and the like) on the basis of the information in the reflected waves, identifying warheads or false targets in the target cluster, and assuring that no warhead will be allowed to get through. If the number of warheads in the target cluster is large, so that the radar tracking system is saturated, the computer must select the most important targets and assure that they will not be allowed through.

2. The computer continuously computes the position of the next radar scan cycle on the basis of target motion parameters. It automatically adjusts the radar receiver and transmitter operating states to the optimal values. When radar operation requires that a target's correct coordinates be determined, the computer can rapidly change from a fast scan broad antenna to a narrow pencil beam for tracking. Of course it can also compress pulse width, thus increasing tracking resolution.

3. The computer assures that the radar uses the optimum beam width and pulse width so that it can distinguish missile warheads in the target cluster, determine the targets' position and characteristics (such as shape, size, attitude, surface material and surface structure) and compare these with holographic signals (prerecorded standard signals for various targets) to carry out target recognition.

4. If the target is maneuvering from one trajectory to another, on orders from the computer radar observes the target at a higher frequency, making it possible to calculate the maneuver trajectories and forecast the target's movements for the ABM system.

5. The computer rapidly relays the various radar measurement signals. It monitors, classifies and processes all measurement data. It oversees and tests the status of the ABM system to determine whether it is functioning normally.

The command center's computer has the complex task of rapidly processing all types of information in the ABM system. Accordingly, the computer is subject to the following requirements.

1. It must have high computation speed. The computer must carry out several million to several hundred million operations per second reliably and accurately. It must be able to rapidly process and relay all types of information, rapidly forecast target trajectories and calculate expected intercept points.
2. It must have memory. It must "memorize" (or store) separately large quantities of target information, ABM information and other data as well as various engagement plans.
3. It must be able to make logical decisions. It must be capable of helping the command personnel analyze and make decisions on all types of situations.

The computer of the US NIKE-X ABM system was a large-scale computer specially developed by Univac Corporation which was capable of 100 million operations per second and consisted of 25 parallel processors. In addition to performing flight trajectories and guidance command computations for the high-altitude Spartan and low-altitude Sprint missiles, the computer also had to perform other tasks such as radar control.

A computer consists of five main components: the arithmetic and logic unit (ALU), the control unit, the memory, the input-output equipment and the power supply as shown in Figs. 6.1 and 6.2.

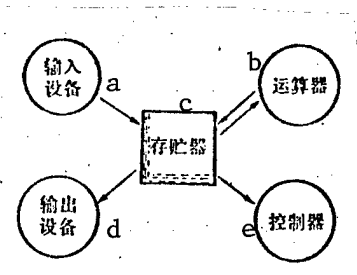
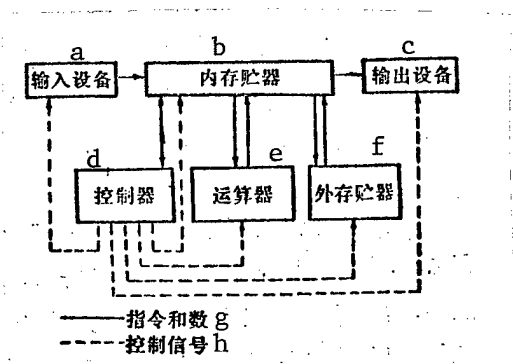

Fig. 6.1. General design of a computer Fig. 6.2. Main components of a computer (Keys to Figs. 6.1 and 6.2 are on the following page)

(Keys are continued from previous page for Figs. 6.1 and 6.2).

Fig. 6.1. General design of a computer
Key:

- a. Input
- b. Internal storage
- c. Output
- d. Control unit
- e. Arithmetic-logic unit
- f. External memory
- g. Commands and data
- h. Control signals

Fig. 6.2. Main components of a computer
Key:

- a. Input
- b. Arithmetic-logic unit
- c. Storage
- d. Output
- e. Control unit

The computer's input device enters the raw data and computation steps on which computations are to be performed, e.g. computer programs written by people (currently the FORTRAN and ALGOL languages are widely used to write programs) into the computer's memory via preperforated paper tape or cards. The usual type of input device is an optoelectronic device, which can convert the mechanical signals on the paper tape into an electrical signal and enter it into the computer. An optoelectronic input device can read more than 1,000 characters or numbers into the computer every second.

The memory is the place in which the computer stores raw data, computation steps and computation results. It is capable of "remembering" the information required for computation and rapidly making it available. Memories are usually divided into internal memory (internal storage) and external memory (external storage). The internal memory reads the data for immediate calculations in and out and usually can store tens of thousands to hundreds of thousands of digits. External memory stores data which has been used in computation but is not currently needed and generally can store more than 10 million digits. The computer uses the binary number system, whose main characteristic is that only the numerals 0 and 1 are used: a result of 2 means carrying a 1. For example, decimal 5 is expressed in binary notation as 101 (see Table 1).

表一 十二进位表

十进制 a	二进制 b
0	0
1	1
2	10
3	11
4	100
5	101
6	110
7	111
8	1000
9	1001
10	1010

Key:

- a. Decimal
- b. Binary

Table 1. The binary and decimal numbers

The arithmetic-logic unit (ALU) is the computer component which carries out all operations; it consists of registers (circuits which temporarily store operation codes, operands and computation results) and adders. Its main characteristics

are that the operations of addition, subtraction, multiplication and division, in addition to logical operations. The ALU performs operations on data at high speed; its operating speed, particularly in performing the four arithmetical operations, is one of the main factors determining the speed of the computer. The shorter the operation time the faster the computer.

The output equipment reads out the final computation results in a specific form (by printing characters or plotting curves or diagrams). There are many types of output devices, such as ordinary wide-line printers, displays and the like.

The control unit's function is to command and control all components of the computer. The control unit controls all functional processes and assures that the operation of the entire computer is automatic; in addition, when it receives an external signal it can transfer the computer to temporary external control. The control unit is one of the more complex components of the computer.

The power supply system provides electrical power to all components of the computer. Because of the computer's characteristics, the power supply must be highly stable and reliable. The operation of the various computer components is shown in Fig. 6.3.



Key:

- a. Paper (storage function)
- b. Computer (computational function)
- c. Operator (control function)

Fig. 6.3. Operation of a computer

At present, the trend in ABM system computers is away from special-purpose computers and toward general purpose computers. In a nuclear war, the important thing is to protect the computer against damage from nuclear effects such as gamma rays, X-rays, neutron flux and electromagnetic pulses so as to assure that the command and control system operates normally.

In combat, the operation of the computer can be summarized as follows.

When the radar detects an enemy missile attack, the computers (several large computers or a jumbo computer) quickly process the measurements, recognize true and false targets in the target cluster, compute the trajectories and impact points of the targets, compute the expected intercept points and times, warhead capabilities, degree of threat and the like, display this information on the displays in the command center, and offer counterattack plans to the person in charge at the command center. Once a combat plan is chosen the command center issues combat orders, the ground-based guidance system uses the computer to formulate control commands on the basis of data on the ABM's and targets, and to control the intercept process.

Chapter 7. Warning Systems and Their "Far-Seeing Eyes"

The sky is limitless: how is it possible to know whether an enemy is attacking in this endless expanse? When an ABM is launched at a target, how is it possible to know whether it hits or not?

People call radar the "far-seeing eye": it is the eye which protects a nation's airspace. Many such "eyes" in various locations, such as long-range radars, over-the-horizon radars and warning satellites, make up the national or regional warning network, the warning system. This is an immense, complex system, which is completely automated. Its task is to detect, provide warning of, acquire and track targets.

The operation of a warning system is similar to the detection and tracking of aircraft as seen in the movies. Warning satellites or over-the-horizon radars constantly maintain surveillance for attacking enemy missiles. If they detect an incoming target (in flight or at launch) they issue a warning, track it, and relay the target information which they determine to the long-range target tracking radar, which tracks the target. The computer calculates the number of targets and assigns target priorities, correctly determines the number of targets, the threatened areas and the degree of danger, and computes the target trajectories, estimates, the intercept point and ground impact point, and provides an all data to the antiballistic missiles. The warning system constantly reports on the air situation to the command center and quickly transmits the information to all elements of the ABM system.

The warning system uses warning satellites, over-the-horizon radars and long-range target tracking radars to detect targets.

Why are such huge warning systems needed?

First, it is not known from what direction they enemy will attack, and second, incoming missiles travel at high speed in high trajectories over long ranges. have great destructive power and use various kinds of penetration measures. Accordingly, only by organizing a nationwide or regional warning network is it possible to deal with missile attacks from all directions and provide the maximum warning time to the defensive systems.

From the ballistic characteristics of offensive missiles given in Table 2 of the appendix [not reproduced] it is clear that an ICBM with a range of 10,000 km takes approximately 30 minutes from launch to ground impact.

Because of the spherical shape of the earth (the ground surface is curved), a long-range warning radar with an operating range of 5,000 km can detect an ICBM only after it has covered half its path, i.e. it is "seen" only after 15 minutes (Fig. 7.1).

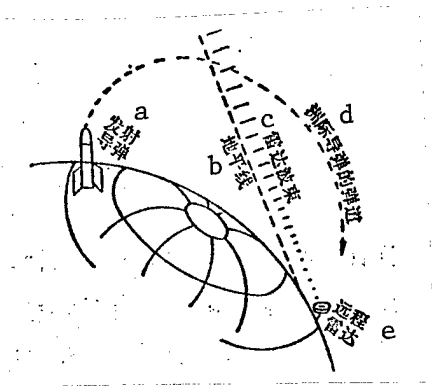

- Key:
- a. Missile launch
 - b. Horizon
 - c. Radar beam
 - d. ICBM trajectory
 - e. Long-range radar

Fig. 7.1. Detection of target by long-range radar

In order to detect targets as early as possible, warning satellites and over-the-horizon radars must be used. Why can warning satellites or over-the-horizon radar "see" around the globe to a target and detect a missile that has just been launched?

Warning Satellites

There is a proverb that "the higher you stand, the farther you see."

Satellites are high in the sky. They "stand" several hundred to several tens of thousands of kilometers up, and naturally they can see extremely far. They can indeed "see and hear in all directions." Accordingly, they are very well suited for monitoring missile launches.

Why are they called warning satellites? In simple terms, they are satellites whose task is to give warning of targets, hence the name.

Warning satellites are one of the important surveillance means in the warning system. They can effectively detect and give warning of missile launches, not only providing longer warning time but monitoring a wider area as well (several thousand to several tens of thousands of square kilometers) and are unaffected by weather conditions, enemy radio transmissions and other interference (see Fig. 7.2).

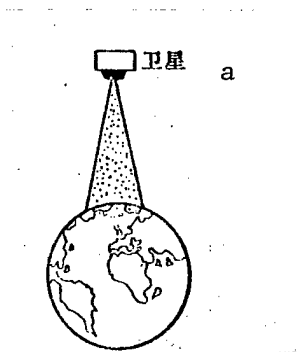

- Key:
- a. Satellite

Fig. 7.2. Warning satellite

Warning satellites generally are placed in synchronous orbit (at an altitude of approximately 35,800 km). At this height the satellite circles the globe once a day. Accordingly, its angular velocity is the same as that of the earth, and seen from the surface it is stationary; accordingly, such satellites are also called stationary satellites.

The launching and entry into orbit of a warning satellite and its movement into a synchronous orbit are described in the book "Satellites and Manned Aircraft."

Warning satellites are equipped with a variety of remote sensing equipment.

1. Infrared sensors are used for remote sensing of the characteristics of a distant object. They can detect infrared radiation; when a missile is launched, its exhaust gases emit large amounts of infrared radiation which can be detected by the sensors, allowing detection of missile launches.

2. Visible radiation sensors such as television cameras record the motion of a missile when it is launched and flies upward, and relay the picture to the air defense command center.

These two types of sensing equipment can be used together to eliminate false alarms. In general, when the satellite's infrared sensors send a warning signal, the air defense command center must analyze the television picture which is relayed and use it to verify the warning signal so as to eliminate false signals.

We now give a brief description of a warning satellite and its operating principles; the example chosen is an early-model foreign warning satellite. This satellite is about 3 meters high and 2.7 meters in diameter. At one end it is equipped with a 3.6-meter-long, 1-meter diameter infrared telescope, so that the total height of the satellite is 6.7 meters. It weighs 900 kg (see Fig. 7.3).

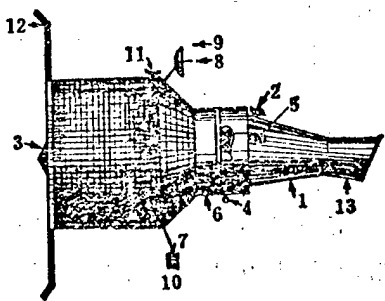

Fig. 7.3. A warning satellite

The satellite is equipped with 13 main types of equipment: 1. Infrared telescope; 2. Visible radiation sensor (television camera); 3. Nuclear blast radiation sensor; 4. Star sensor of attitude control system; 5. Sensor of orientation system; 6. Onboard electrical equipment; 7. Antenna for transmitting infrared sensor signals to ground; 8. Antenna for transmitting television picture to ground; 9. Antenna for receiving commands; 10. Auxiliary nuclear blast detection sensor; 11. Nozzle of triaxial attitude control system thrusters; 12. Solar battery panels; 13. Solar screen to protect telescope and infrared sensor.

It can be seen from the figure that the warning satellite's direction and stability in space are maintained by thrust nozzles, that it obtains electric power from the solar battery panels, that the solar sensor aligns the battery panels toward the sun, and that the nuclear radiation sensor detects nuclear explosions, so that the satellite detects not only missiles but nuclear explosions as well.

The infrared sensor on board the warning satellite is an array-type sensor consisting of 2,000 lead sulfide sensor cells, each of which covers an area of 13.7 square kilometers, so that the total area covered at one time is 27,400 square kilometers. When the satellite is in operation, the sensors are pointed toward the ground surface below and carry out a regular scan. The electrical signal from the infrared sensors is fed through a modulator, amplifier and digitizer for transmission to the ground. The visible radiation sensor is a television camera. When the infrared sensor detects a missile launch, the visible radiation sensor is automatically turned toward the missile and the satellite automatically transmits a television image to the ground. The warning satellite detects missiles very quickly, generally within one minute of launch. But the warning satellite has a weak point, namely that the sensitivity of the infrared sensor decreases with length of service, in addition to the problem of false alarms (false reports, false target data and the like). Accordingly, warning satellites must be used together with the over-the-horizon radar and long-distance tracking radar or onboard radar in the early warning system.

Radar, the Far-Seeing Eye

Radar is also called the radio location equipment. It is electronic equipment which emits electromagnetic waves that are reflected by distant objects and received again, thus making it possible to detect and locate targets. By using radar, flying targets such as ICBM's can be detected at distances of several thousand kilometers and their range, bearing and speed can be determined; accordingly, radar is an important component of the air defense system. Targets which can be identified by radar include those in the air, on water and on land.

Radar systems generally consist of a timer, a transmitter, a receiver, and an antenna, a display and a computer, as shown in Fig. 7.4.

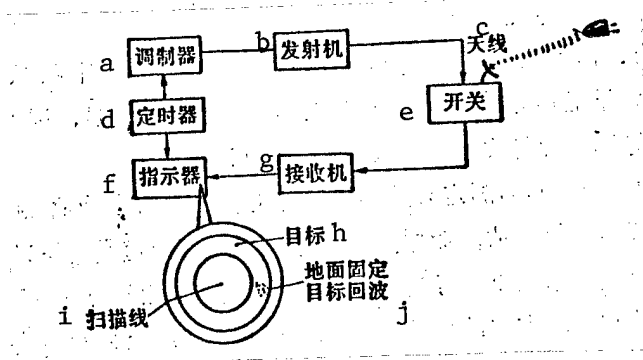

Key:

- a. Modulator
- b. Transmitter
- c. Antenna
- d. Timer
- e. Switch
- f. Indicator
- g. Receiver
- h. Target
- i. Sweep indicator
- j. Reflections from fixed surface objects

Fig. 7.4. Main components of a radar system

Because radar can enable us to "see" or detect targets and identify their position at distances far exceeding the range of the human eye, even in dark, fog, clouds, smoke or other conditions unsuited to visual observation, people call radar the "far-seeing eye." Some people even say that radar is the sentinel and searchlight of the modern battlefield, the commander's eyes and ears, and the "eagle's eye in the sky." In 1938 England was the first to set up a short-wave coastal warning radar.

The operating principle of radar can be summarized as follows. The transmitter emits a very strong radio signal which, when it encounters an object, is reflected from it to the radar receiver; the characteristics of this reflected signal are used to form an image of the target or to locate it, as shown in Fig. 7.5.

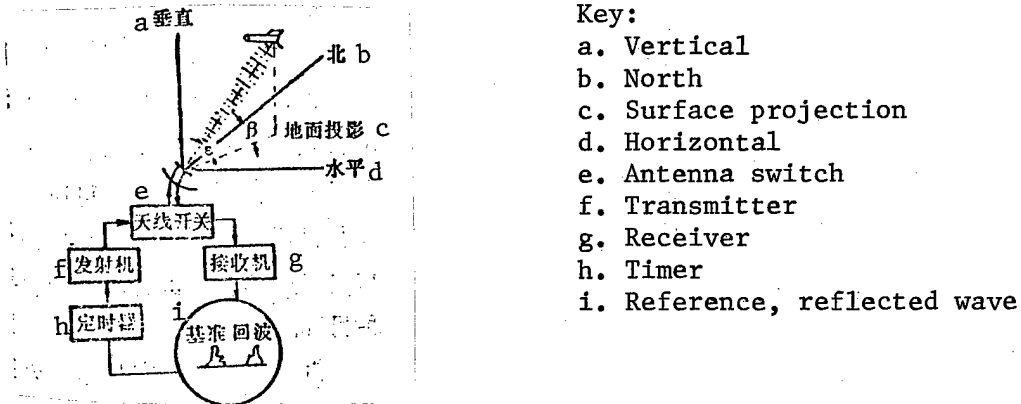
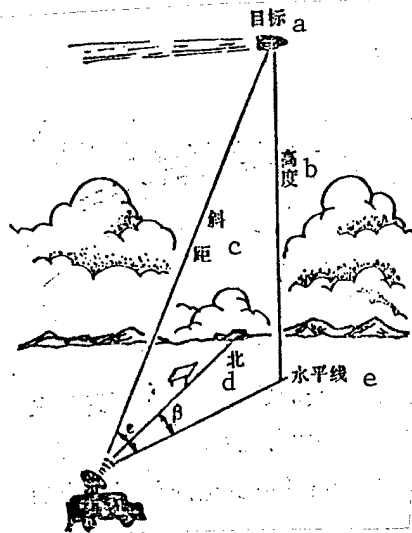

Fig. 7.5. Radar operating principles

Radars for different uses are subject to different design requirements. For example, ballistic missile warning radars are used against small, high-speed maneuverable targets which employ various penetration techniques, and accordingly they must have the following characteristics.

1. Long range. They must detect and track incoming targets at distances of several thousand kilometers. If they provide early target information, the antiballistic missile preparation time will be sufficient; accordingly it is best that they be able to detect missiles at or shortly after launch.
2. They must determine precisely the trajectories of incoming missiles. They must quickly and correctly determine the ballistic characteristics of the targets, and estimate the intercept point and ground impact point. The target trajectory data can be given in terms of the range R (from the radar station to the target), the bearing B (the angle between true north and a line from the radar station to the target), the elevation angle E (the angle between a line from the radar station to the target and the projection of the line on the ground surface), and the rate of change or range (Fig. 7.6). With these four parameters (or the first three) mathematical methods can be used to compute the target's trajectory, intercept point and ground impact point.



- Key:
- a. Target
 - b. Altitude
 - c. Slant distance
 - d. North
 - e. Horizontal

Fig. 7.6. Radar measurement

3. It must be able to recognize targets effectively. It must have the ability to recognize true and false targets in a target cluster and analyze and determine target types from their characteristics.

4. It must be able to track many targets and maneuvering targets. It must be able to lock on to individual targets in a target cluster and to maneuvering targets.

5. It must have high reliability and fast, reliable data processing ability.

The radars in the warning network generally include over-the-horizon radars, large phased array radars and long-range surveillance and tracking radars.

Because electromagnetic waves propagate only in straight lines, most radar waves (very short waves or microwaves; see Table 2 in appendix, "Subdivisions of the Radio Spectrum") propagate only in straight lines, so that they are limited by the shape of the earth and can detect only targets in line-of-sight range, not targets below the horizon (Fig. 7.7).

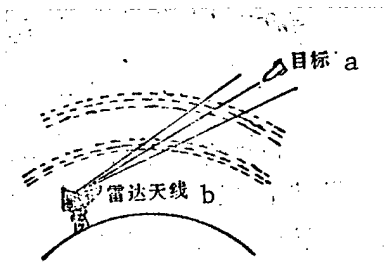

- Key:
- a. Target
 - b. Radar antenna

Fig. 7.7. Radar location

If a missile launched by the enemy is below the radar's horizon, how can it "see" the missile?

Over-the-horizon radar must be used.

Over-the-Horizon Radar

The radio waves emitted by over-the-horizon radars are "bent" at a certain angle when they reach the ionosphere, thus passing over the horizon, so that they can detect objects below the horizon as shown in Fig. 7.8.

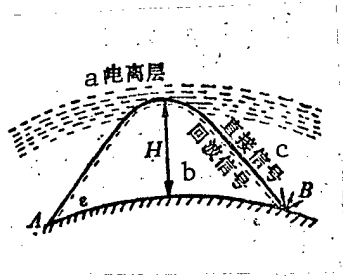

- Key:
- a. Ionosphere
 - b. Reflected signal
 - c. Directly emitted signal

Fig. 7.8. Reflection of a signal sent from the ground

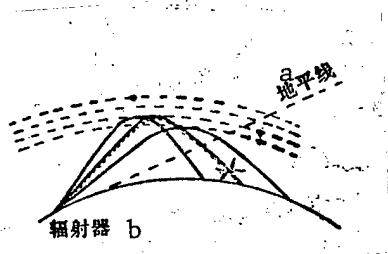

- Key:
- a. Horizon
 - b. Radiator

Fig. 7.9. Reflection of signal from object

The concept upon which over-the-horizon radar is based was proposed in 1946, and subsequently the United States began development of this type of radar in an attempt to solve the problem of early detection of aircraft and missiles.

Because short wave electromagnetic radiation reflected from the ionosphere, and returning to the earth's surface can be scattered in all directions by the atmosphere, some of the scattered energy is scattered in the reverse direction and propagates along the same path as the original signal, returning to the initial transmission point. If there is some body (such as a missile or aircraft) on the electromagnetic propagation path between the earth's surface and the ionosphere, the radiation reflected from it will return and be recorded at the point of transmission (see Fig. 7.9). This is the basic principle of over-the-horizon radar.

When this principle is used, the operating distance is determined by the skip interval, which in turn depends on the elevation angle E and the altitude H of the reflective layer in the ionosphere (which is variable). It is generally thought that the operating range of a single-skip over-the-horizon radar is 3,800 km.

On the basis of the type of propagation, over-the-horizon radars can be classified as forward-scatter and backscatter types.

The transmitter and receiver of forward-scatter over-the-horizon radar are generally located far apart, as shown in Fig. 7.10. After the electromagnetic radiation is emitted by the transmitter, it propagates by ionospheric skip and is received by a receiver in a different location. When a missile is launched at a location in the path of the wave and creates an atmospheric disturbance, a change will appear in the received signal, making possible to detect the target. The advantage of this type of radar is that it is rather simple, but in general it can indicate only the existence of a target and its general direction, but cannot be used to determine the range of the target or other data on it.

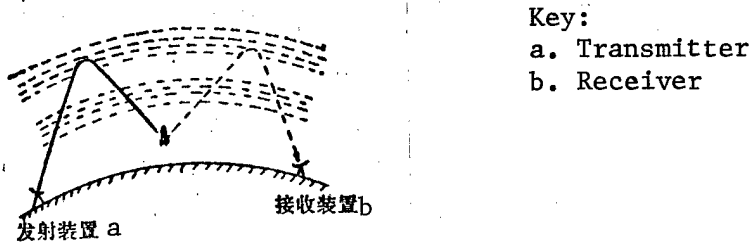

Fig. 7.10. Over-the-horizon forward-scatter radar

In over-the-horizon backscatter radar the transmitter and receiver are located at the same place (see Fig. 7.9). The transmitter emits a short-wave signal whose sky wave is reflected one or more times between the ionosphere and the surface of the earth, allowing it to reach locations below the horizon. When the wave reaches the target, it again propagates as a sky wave and is received by the receiver; following signal processing, objects below the horizon can be displayed.

This type of radar not only can indicate the existence and direction of targets but can be used to determine the range R of the target in terms of the signal delay time (the difference Δt in time between emission and reception of the signal) using the formula $R=1/2C \times \Delta t$ (where $C \approx 3 \cdot 10^8$ m/sec is the speed of light), as well as to find the target's velocity using the Doppler effect.

Because over-the-horizon radar operates in the short-wave region, the problem of interference (from ionospheric changes, thunderstorm noise and the like), arises, along with other problems, and accordingly to resolve the main contradictions involved in over-the-horizon radar requires development of high-powered transmitters and larger antennas, increased noise immunity, and improved signal processing techniques.

The main advantage of over-the-horizon radar is that it can detect targets below the horizon and at very long ranges (about 3,800 km for single reflection and 7,600 km for double reflection), its detection range is long, and it can provide antiballistic missile systems with about 30 minutes' warning, while ordinary radar provides only 3 to 15 minutes' warning. But its measurement precision is poor, and in particular it is difficult for it to provide accurate ballistic data for the middle part of a missile's trajectory. One US over-the-horizon radar has a locating precision of approximately 16 km and a bearing angle precision within a few degrees. In addition, its capabilities are poor, the

antennas are large and long (the US Ji Mao [phonetic] IV radar is 400 m long and 60 m wide) and are exposed on the ground surface, where they are vulnerable, and nuclear blasts produce atmospheric interference, preventing this radar from working normally. In order to improve over-the-horizon radars and overcome the current weak points, it will be necessary to intensify technical research, including basic research in short wave radio propagation, in order to master techniques for real-time monitoring of ionospheric changes so as to allow real-time selection and control of optimal operating frequencies and suitable emission angles in terms of ionospheric changes; there is also a need to develop frequency-agile high-power transmitters and signal processing techniques and to deal with the problem of extracting weak signals from reflected waves and interference. Accordingly, this radar must be used in combination with long range surveillance and tracking radars, which will complement it.

Long-range or superlong-range surveillance radars (also called long-range warning radars) are another type of component of warning systems. Currently some of them are monopulse radars while others are phased array radars; the latter type is widely used abroad.

Phase Array Radars

What are phased array radars?

"Phased" means that the phase of the radio waves emitted by the antenna can be controlled, and "array" means that the antenna consists of thousands or tens of thousands of radiators (radiators are classified as active or passive: active radiators are small antennas which can emit a radio wave, while passive radiators cannot emit radio waves) which are arranged in regular rows and columns to form an "array." Accordingly, phased array radars are array antennas using elements in which the direction of the beam can be altered by controlling the phase of the excitation signal applied to each element. It is an electronic scanning radar whose antenna does not need to be moved mechanically. Accordingly, it can constantly track targets coming from any direction.

The difference in construction between phased array radars and ordinary radars is primarily that phased array radars have thousands or tens of thousands of radiator elements, phase shifters and their exciters. The key to the phased array is its phase shifting capability. The phase shifters shift phase quickly under computer control. In addition, the radars have highly automated control systems, and the beam control and alteration of operating characteristics are carried out automatically.

Because the phases of the signals emitted by the various radiators are controlled by computer, reaction speed is high and they are precise and reliable. The advantages of phased array radars are as follows.

1. The beam sweep is inertialess and the beam direction can be changed within a microsecond, several million times faster than with mechanical sweep motion, achieving extremely high data speeds, which is what is required for dealing with high-speed missiles; in addition, a single beam can carry out various different functions, such as surveillance, target acquisition and tracking, almost simultaneously.

2. It has multiple capabilities, and by controlling the various radiators' phases it is possible to form multiple independently-operating beams (the power and gain of each beam is adjustable), and multiple targets can be simultaneously searched for and tracked. In addition, a single high-power, high-gain beam can be produced to search extremely distant sky areas, in which case the beam shape also may be broadened for rapid search of the entire sky area. Furthermore, by using multiple beams, multiple functions such as search, acquisition, recognition and tracking can be performed simultaneously, and antiballistic missiles can be guided toward their targets, so that a phased array radar can replace several radars of different types.

All operations of phased array radars is controlled and automatically performed by high-speed computers; the computer programs can adapt to a changing environment by means of self-adaptive methods, i.e. they can quickly determine the optimal operating mode for a rapidly changing target movement situation and flexibly control the beam and efficiently allocate power in order to meet various complex requirements, in other words, this type of radar has a self-adaptive capability.

4. In large-size phased array radars, the power of the radiators can be varied from several high-power signal sources to hundreds or thousands of low-power signal sources, so that the total radiated power can be very high and the operating range very great.

5. Phased array radars can be viewed as consisting of a number of smaller radars, and accordingly the malfunction of some of the small radars, e.g. malfunctions in a few radiators or a small number of low-power sources has little effect on normal operation of the phased array; in other words, reliability is rather high.

6. The antenna array is fixed and can be made very strong, which is helpful in withstanding shock waves from nuclear blasts.

From this it is clear that the antenna beams of phased array radars are highly flexible, and when operated by a high-speed computer they can perform rapid scanning and a wide range of other functions, including search, tracking recognition and prioritizing of objects flying in earth orbit or incoming missiles; accordingly they are rather well suited to the requirements of ballistic missile defense.

Monopulse Radars

Monopulse radars can be used for precise target tracking and recognition.

But what are monopulse radars?

Monopulse radars can provide all information on target angular position from a single pulse, hence the name. Because they use only a single pulse to determine direction, the amplitude of the reflected signal cannot affect the precision of angular coordinate measurement and the radar has the advantages of high measurement precision and good noise immunity.

There are two basic methods of direction finding in monopulse radar, the amplitude method and the phase method. In amplitude comparison monopulse radars the antenna generally sends out four slightly overlapping beams, above, below, left and right, as in Fig. 7.11. The amplitudes of the left and right beams are compared to determine the directional angle and the amplitudes of the upper and lower beams are compared to determine the elevation angle; direction and elevation are determined in the same manner. Here we will describe only the determination of elevation.

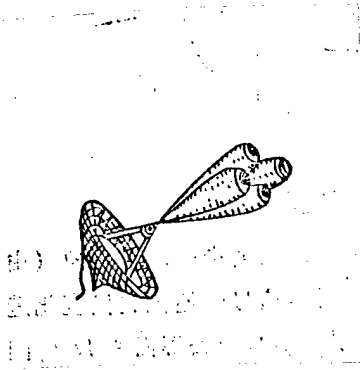
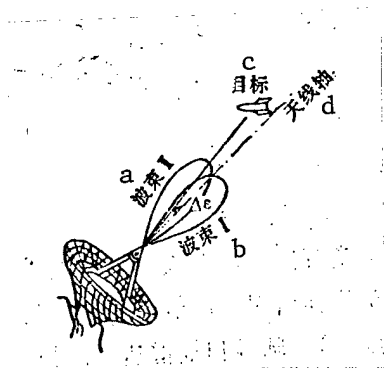

Fig. 7.11. Amplitude comparison monopulse radar emitting four slightly overlapping beams



- Key:
- a. Beam 2
 - b. Beam 1
 - c. Target
 - d. Antenna axis

Fig. 7.12. Principle of signal comparison method

The amplitude comparison monopulse radar uses the signal comparison method shown in Fig. 7.12. When the target is off the antenna axis, for example above it, the reflected signal from beam 1 which is received will be much stronger than that from beam 2, and by comparing the strengths of the two signals it is possible to determine the vertical elevation angle deviation ΔE . Because monopulse radars emit two beams simultaneously, while ordinary conical-scan radars (ordinary tracking radars now used primarily in tracking aircraft, gun direction and surface-to-air missile guidance, see Fig. 7.13) emit only one beam and cannot carry out immediate comparison, they use repeated reception of reflected waves for the purpose of comparison. In order to obtain angular information on the target, conical-scan radars generally must perform one conical-scan cycle, i.e. must emit and receive several dozen pulses. This is the respect in which they differ from monopulse radars.

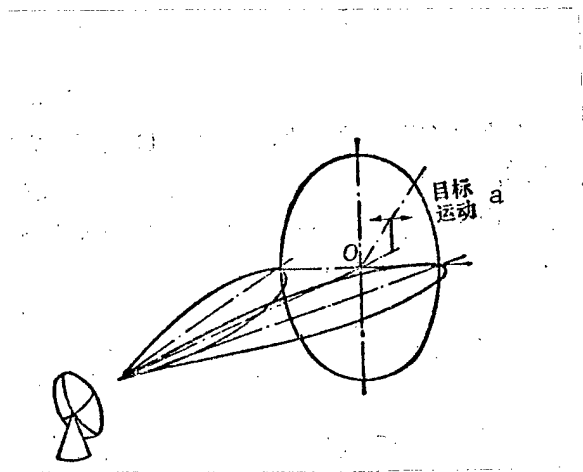

Key:

a. Motion of target

Fig. 7.13. Conical-scan radar

Because of the complexity of the external shape of incoming missiles, vibration during flight and frequent changes in attitude, the reflected radar wave flickers (because of the variation of the reflected signal and random fluctuation of the reflected signal). Conical-scan radars emit many pulses over a relatively long time interval and are subject to reflection flicker, so that the angular detection precision is only 1 or 2 mils (1 mil = 0.06°), while monopulse radars are not subject to reflection flicker, and their angular measurement precision may be as high as 0.01 mils. This is one of their advantages.

Some common monopulse radar types are: amplitude comparison monopulse radars, pseudo-monopulse radars, phase comparison monopulse radars and the like.

Their operating principles are briefly described below.

1. Amplitude comparison monopulse radars.

The operating principle of amplitude comparison monopulse radars can be seen in Fig. 7.14. The emitter sends out beams to measure the elevation; if their phases are the same, they are both indicated by a "+" (Fig. 7.15). The two beams strike the target and are reflected and received by the antenna. They are then compared by a high frequency comparator which puts out a sum signal and a difference signal. The sum signal is equivalent to the addition of the overlap directions of the two beams shown in Fig. 7.15a; they add in every direction, producing the directional pattern shown in Fig. 7.15b. The difference signal is equivalent to subtraction of beam 2 from beam 1 in every direction, producing the pattern shown in Fig. 7.15c. The sum and difference signals are separately analyzed and processed in the receiver, then compared in the phase comparator, which outputs an antenna displacement control signal. If the difference signal is zero, the control signal is also zero, in which case the antenna axis is already aligned on the target; if the difference signal is not equal to zero, a control is emitted and the phases of the sum and difference signals are compared to determine in which direction the antenna axis should be moved. The sum signal is used not only to determine the phase reference signal but also as the distance measurement signal, since as the sum of two beams it has twice the power and is best suited for distance measurement. This is a simplified description of the principle by which the elevation angle is measured.

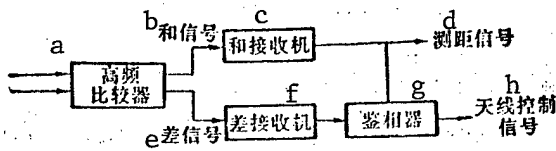

Fig. 7.14. Operating principle of amplitude comparison monopulse radar

Key:

- a. High frequency comparator
- b. Sum signal
- c. Sim signal receiver
- d. Distance determination signal
- e. difference signal
- f. Difference signal receiver
- g. Phase comparator
- h. Antenna control signal

If the bearing is determined at the same time as the elevation, the right and left beams are subjected to high frequency comparison, after which the sum receiver, the bearing-determination difference receiver and the phase comparator used to produce the bearing control signal. In reality, the monopulse radar has only one sum receiver and two difference receivers. The sum signal actually combines the upper, lower, left and right beams; the elevation difference signal is obtained by comparing upper left plus upper right with lower left plus lower right, and the bearing difference signal is determined by comparing upper left plus lower left with upper right plus lower right.

2. Phased monopulse radars. Phased monopulse radars make use of the phase difference between received signals to determined target direction; the amplitude of the received signal generally is unrelated to the target direction. The antenna emits four beams, generally parallel, as shown in Fig. 7.17a. The actual antenna structure is shown in Fig. 7.16b. The four beam antennas are separate and distinct.

(Fig. 7.16 and 7.17 and their keys are continued on the following page).



图 7-15

- a—两个交叉波束的方向图,
- b—两个波束和的方向图,
- c—两个波束差的方向图.

Fig. 7.15.

Key:

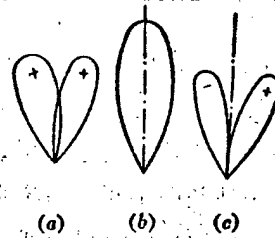
- a. Direction pattern of two overlapping beams
- b. Direction pattern of sum of two beams
- c. Direction pattern of difference to two beams



图7-16 相位单脉冲雷达的发射天线
a—四个平行波束；b—天线结构示意图。

Fig. 7.16. Phase comparison monopulse radar transmitting antenna

Key:

- a. Four parallel beams
- b. Structure of antenna

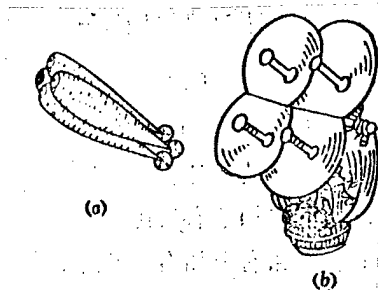
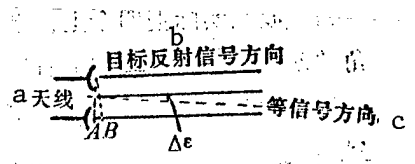

Fig. 7.17. Principle of direction finding from phase

Key:

- a. Antenna
- b. Direction of signal reflected from target
- c. Direction of signal equivalence

As shown in Fig. 7.17, the operating principle of phase comparison monopulse radar is similar to that used in phase direction finding. Because the antenna is linearly arranged, the radar beams are parallel, and the equal-signal direction of the antenna beam is directly ahead of the antenna radiators. When the target is very far from the antenna, the signals reflected from it are nearly parallel and have equal amplitudes, but their phases differ. The signal shown at the bottom in Fig. 7.17 must travel a distance longer than that traveled by the top signal by a distance AB . AB is very short and does not affect the strength of the signals, but it has a great effect on phase. Because the radar operates in the microwave region, the wavelength is usually several centimeters. If AB is equal to the wavelength, the phase difference will be equal to one wavelength or 360° . If AB is half a wavelength, the phase difference will be 180° . The length of AB is related to the target deviation angle $\Delta\epsilon$ and accordingly the phase difference measured by the antenna can be used to determine the direction in which the target is off the antenna axis. Phase monopulse radar is basically similar to amplitude comparison monopulse radar, but there are some differences in the appearance of the antenna and the phase comparator. Currently most monopulse radars are of the amplitude comparison type, but a considerable number are of the phase comparison type.

3. Pseudo-Monopulse Radar

Because monopulse radar requires three receivers and is rather complex in design, a simplified monopulse radar called pseudo-monopulse radar has been developed. In this type, the sum and difference signals, three in all, are combined, so that only one receiver is needed. When the two difference signals are mixed, the pulse signal amplitude is modulated in a fashion similar to that used in

conical-scan radar, in addition to which a reference signal similar to that used in conical-scan radar is created, so that after amplification in the receiver, the two difference signals can again be separated. Accordingly, this type of pseudo-monopulse radar is also called "hidden conical-scan radar", since the radiator operates as in monopulse radar but reception somewhat resembles that used in conical scanning. Monopulse radar is less vulnerable than conical-scan radar to destruction by antiradar missiles and to inverted-phase jamming, but like conical-scan radar it is affected by target reflection flicker, and it is difficult to achieve angular measurement precision: the usual precision is slightly more than 1 mil. There are certain other methods for combining the three receivers into one, and in some approaches they are combined into two. Because of its simplicity of design, pseudo-monopulse radar is now in rather extensive use.

Chapter 8. Penetration and Antipenetration Techniques

In antiquity, warriors wore armor and fought hand to hand with swords and spears, arrows against arrows and steel against steel. The weapons used in peasant uprisings also were arrows, swords, daggers, spears and the like.

Use of armor to protect the body was a defensive measure.

Piercing through the armor to kill or injure the adversary was a kind of "penetration."

Striking away the weapon with which an enemy tried to pierce one's armor was a form of "antipenetration."

The above are examples of defense, penetration and antipenetration in antiquity. But what form do these take today? Naturally, ancient armor cannot provide defense against attack by nuclear missiles, but research on defensive weapons has never ceased. What techniques are used today to defend against nuclear weapons? One such technique is antiballistic missiles.

But is it possible to penetrate an antiballistic missile defense?

This is the technical question, increasingly studied today, of penetration and antipenetration.

An Overview of Penetration and Antipenetration Techniques

When ICBM's appeared, so did the problem of dealing with them. Every offensive has its corresponding defense: this is a historical necessity. Penetration and antipenetration techniques developed in response to the development of ICBM's and ABM's.

Penetration means breaking through the enemy's defenses against offensive weapons, paralyzing or partially paralyzing all or part of the defensive system so that it (e.g. ABM's and the like) becomes ineffective.

Antipenetration refers primarily to the defeating of the various measures by which the enemy attempts to attack with missiles, so that the offensive missiles are destroyed by the defensive system before they reach their objectives.

Because of rapid improvement of the warning and interception capabilities of strategic air defense systems, in order to break through the enemy's defenses, development of strategic nuclear weapons has included not only increases in numbers, expansion of range, improvement of accuracy and survivability, but also the use of various penetration techniques such as the use of multiple warheads and maneuvering warheads.

The term "multiple warheads" refers to the use of several warheads carried in the same ICBM to attack one or several targets, as shown in Fig. 8.1.

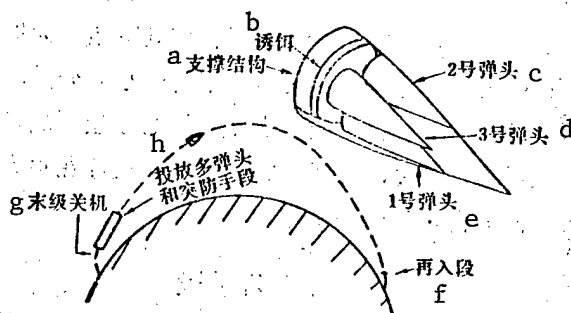

Key:

- a. Supporting structure
- b. Decoys and chaff
- c. Warhead No 2
- d. Warhead No 3
- e. Warhead No 1
- f. Reentry stage
- g. Last stage of delivery rocket
- h. Release of multiple warheads or penetration aids

Fig. 8.1. A multiple-warhead reentry vehicle

Maneuverability refers to a warhead's ability to change its trajectory while in flight in order to attack its target. There are now two techniques for changing trajectory, namely full-course maneuver and terminal maneuver. Full-course maneuver means, that after the warhead separates from the missile it continues to climb for several tens or more than a hundred kilometers, then follows a planned trajectory or again climbs to a higher altitude, gradually descends, gliding for some distance, and finally falls to its predetermined target along a planned trajectory. Terminal maneuver means that the warhead first follows a normal trajectory (an elliptical orbit) without maneuvering as it reenters the atmosphere, as if to make an attack, then suddenly starts its maneuver engines and changes trajectory, attacking a preplanned target by a different trajectory. It is reported abroad that maximum terminal-stage maneuver capability can enable a missile to attack targets several hundred kilometers to one side or in front of its false target. Multiple warheads and maneuvering warheads are now gradually coming into use.

The penetration-antipenetration struggle is developing in many areas of the missile field. Take radar as an example: in order to deal with multiple warheads and other penetration techniques, US ABM system radars have been converted from mechanical scanning monopulse radars to electronically scanned phased arrays. The Nike-Zeus system used four independent mechanically-scanned radars for acquisition, tracking, recognition and ABM guidance. The Nike-X system no longer used the mechanically scanned radars, which could not deal with multiple warheads and had poor resistance to nuclear blast, but changed over to phased array radars. In order to improve reliability and survivability, the radars were made small

and decentralized instead of large and concentrated; simple, cheap, multiple-capability small (tactical) multipurpose phased array radars were developed. To summarize, in order to adapt to penetration, the US and Soviet Union have expended much effort on radar improvements.

Several Penetration Aids

Penetration techniques have developed rapidly, so that there is now a considerable number of them (see Fig. 8.2), including simple penetration of ABM systems and active methods for destruction or jamming of defensive radars and other electronic equipment. The aim of the former technique is to render enemy ABM's incapable of intercepting the attacking warheads, while the aim of the latter technique is to destroy the detection capabilities of the enemy radars so that they cannot determine the range and direction bearing and elevation of the attacking missiles.

How is it possible to break through enemy ABM interceptors? There are several techniques that are under development or have been proposed.

1. The use of multiple independently-targeted warheads [MIRV]. A "bus" is equipped with a main engine and several attitude control engines which are used to correct flight error and adjust its speed and direction. While in flight, the bus ejects the warheads singly or at the same time. Each of the warheads may attack a different target, or they may attack the same target by different trajectories. The warheads in a multiple-warhead reentry vehicle generally lack motive power and control equipment and cannot maneuver after being released, but fly to their targets by inertial trajectories. Warhead release techniques now in use include release of the warheads along the bus's trajectory (see Fig. 8.3) or perpendicular to it (Fig. 8.4). This allows a cross-fire attack on one target or staggered attacks on it.



图8-2 各种突防手段示意图

1—假目标，2—反导弹，3—带无线电干扰的弹头，4—空中核爆炸，5—机动弹头，6—多弹头分导。

Fig. 8.2. Penetration aids

Key:

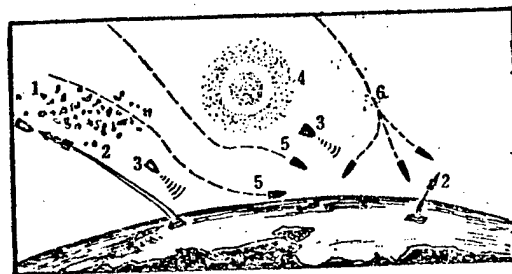
- | | |
|---------------------------------------|---|
| 1. Decoy | 4. Nuclear explosion in space |
| 2. Antiballistic missile | 5. Maneuvering warhead |
| 3. Electronic countermeasures warhead | 6. Multiple independently-targeted warheads |

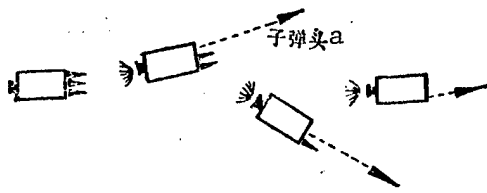

Fig. 8.3. One technique of multiple warhead release

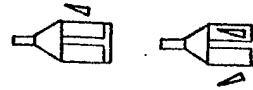

Fig. 8.4. Another type of multiple warhead release

Key:

a. Warhead

2. The use of maneuverable warheads [MARV]. Because there are limitations on the penetration capabilities of MIRV's, each warhead may be provided with motive power and control devices so that it can maneuver, change its trajectory and automatically home on and hit a target using onboard homing devices; this penetration technique is called maneuvering multiple warhead penetration. Because each of the individual warheads can maneuver, it is difficult for the defensive system's radars to acquire and track them, and thus the warheads avoid interception.

3. Hardening the warheads enables them to pass through and withstand ABM nuclear blasts and radiation areas as they carry out their missions. This technique requires new radiation-proof protective materials, improvement of guidance systems, and nuclear blast-resistant electronic equipment.

4. Use of unusual (high or low) trajectories to avoid detection and tracking by defensive radars, making sudden attacks on key objectives, missile silos or defended areas.

5. Simultaneous launching of large numbers of missiles to create very large target clusters in order to saturate the enemy's defensive systems and render them unable to track the real targets.

In addition to the interception-avoidance techniques described above, active destruction and jamming of enemy defensive systems is another important penetration technique which will be used in future nuclear warfare. For example, in order to interrupt the enemy's command processes, blind his radars and disrupt his weapons control requires the use of various methods to destroy or jam his radars and other electronic equipment. As described above, radars emit electromagnetic radiation, which strikes the target and is reflected, and the radar uses the reflected radiation to determine the target's position and speed at a given moment and determine the proper "lead," making it possible to guide ABM's to intercept the targets. Using these characteristics of radar it is possible to jam it. Releasing chaff or decoys is one penetration technique used by ICBM's which can confuse ABM warning systems. Types of interfering materials include metal, metallized materials and semiconductors. False targets made with these materials resemble real warheads, making it possible to track enemy radars into mistaking them for real targets.

The chaff may be released when the warhead separates from the missile, producing an interference cloud accompanying the warhead. This chaff drifts along the missile's trajectory, turning over and over and moving at approximately the same speed as the warhead in the rarefied part of the atmosphere. This chaff cloud renders moving target indication radars unable to distinguish warheads from chaff (see Fig. 8.5).

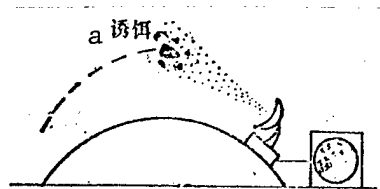

Key:
a. Chaff

Fig. 8.5. Deceptive interference

Interference with radar and other electronic equipment can involve either the production of interference clouds or the release of countermeasures devices. For example, a rocket or missile may be used first to disperse countermeasures devices (see Fig. 8.6), which carry frequency-adaptive transponders capable of creating many false targets. If a transponder is illuminated by enemy radar it can emit an intensified pulse signal very similar to that from a real warhead, so that the enemy warhead will mistake it for a real target.

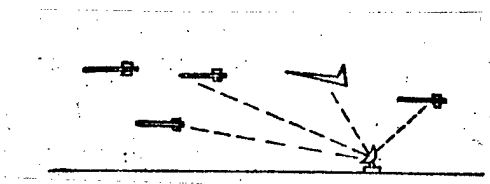

Fig. 8.6. Spoofing interference (countermeasures devices)

It is also possible to take preemptive action with penetration techniques: if a nuclear weapon is detonated in the air above the defended area it can put enemy electronic devices out of commission so that the missile attack cannot be detected; or antiradar missiles may first be launched, directly attacking the enemy air defense radars and killing or wounding their operating personnel, so that the air defense system loses its "eyes." Warheads of this type generally are equipped with a small radar unit with a flat extension at the forward end and four spiral antennas; these do not emit signals, but only receive signals from ground-based radars and automatically adjust the direction of flight in terms of the equality or inequality of the signals received by the four arms, thus guiding the warhead to the radar. When the radar is within its lethal radius, the warhead explodes, thus attacking the defensive radars.

Decreasing the effective radar cross section of warheads and thus decreasing the probability (i.e. likelihood) of detection by enemy radars, or coating the warhead with radiation-absorbing paint so that the enemy radars can obtain no information from reflected signals, as are other penetration techniques.

Recognition Techniques

Recognition techniques are the basis of antipenetration measures.

Recognition techniques must be able to distinguish true and false targets within a large cluster, i.e. to pick out the signals reflected from attacking missiles among those coming from the cluster, thus recognizing the real warheads. Recognition is a very important problem of ABM systems. Below we briefly describe the basic principles of two recognition methods.

The first method is atmospheric filtering. Sand in grain (such as rice or wheat) can be sieved out. True and false targets in a target cluster can also be "sieved out" by the atmosphere, as a result of the difference in the atmosphere's effects on true and false targets (objects of different shape), and thus distinguished. Since different objects are subject to different atmospheric resistance in the dense atmosphere, there will be obvious differences in their speeds of movement. When the target cluster enters the atmosphere, as a result of atmospheric resistance (related to the density of the atmosphere, the shape of the object, its cross section, speed of movement and the like), the light targets and those of irregular shape (such as fragments of the final stage of the missile) will begin to slow and will fall behind the warheads. The use of filtering by the atmosphere to recognize true and false targets is called "atmospheric filtering."

The atmospheric "sieve" can only recognize true and false targets entering the dense atmosphere. It is ineffective against targets outside the atmosphere, and accordingly other methods must be used there; these include radar techniques.

Radar recognition uses special radars. The recognition radar tracks the signal returning from the target, which include information on the target's position and speed and the frequency of changes in the target's reflective surface. These "target characteristic" signals can be compared with known holographic target characteristic signals based on large numbers of measurements, using a high-speed computer, to distinguish true and false targets.

There are many types of radar recognition methods. Here we describe the use of radar wave polarization recognition. When the radar illuminates the target the target produces various effects on the radar wave, one of which is to change its polarization (direction of change of the electromagnetic field). The polarization of the returning wave received by the radar (i.e. the direction of the magnetic lines of force) is not the same as that of the emitted wave, and accordingly the target can be viewed as a "polarization converter."

Analysis of the reflected wave polarization provides recognition data. For convenience, we express it in terms of the scattering coefficient matrix, which consists of the polarization components of the reflected wave and indicates the relation of the target's scattering (reflection) characteristics to radar beam polarization and the relationship between emitted and reflected power for the target. It has been found in practice that the characteristics of a given object can be described in terms of its shape, size, attitude, surface material and surface structure. The scattering coefficient matrix can also be expressed in

terms of these five characteristics. In other words, a given type of target corresponds to a certain type of scattering coefficient matrix. Accordingly, the matrix can be used for recognition of the target.

The target scattering coefficient matrix can be determined in many ways, such as direct determination, by sending out two orthogonally polarized waves in succession and receiving the two polarization components from each. When the object's attitude changes, the radar determines a "picture matrix" (numerical matrix) on the shape, size, attitude, surface material and structure from each viewing angle. The different attitudes of a given object can produce many "picture" matrices. Each picture matrix can be viewed as a curve traced in a 5-dimensional space by the five factors. A multitude of picture matrices for various types of known objects in different attitudes can be stored in a computer. When the radar is tracking an unknown object, the data on its five characteristics can be compared one by one with images of the many known objects stored in the computer, and the unknown object can be recognized by its coincidence with the "picture" of one of the known objects.

Target recognition techniques have still not been perfected, and accordingly other methods are being explored. Certain crude target recognition methods are usually used for preliminary target recognition. For example, objects in space can be classified in terms of their different motion characteristics. Experience indicates that a target's dynamic characteristics, energy reflection and radiation characteristics, and interaction with the surrounding medium provide data for preliminary classification (distinguishing warheads from satellites, meteors, aircraft and the like). Laser devices, doppler optical locators and high-resolution optical locators for identifying an object's shape can be used to determine the ways in which the reflection and radiation characteristics of warheads and false targets differ, making it possible to distinguish them.

The shock waves produced in front of flying objects and the high-heat-energy trails behind them are also dynamic characteristics which can be used to distinguish true and false targets. Their energy reflection and radiation are also dependent on the particular stages of the trajectory. In the middle stage of the trajectory the majority of the radiation emitted is infrared. In the reentry stage the radiation around the warhead consists of heat radiation (high temperature) and infrared radiation. When the target is slowed by atmospheric resistance, the quantity of energy produced is related to the mass of the target and its velocity, and the nature of the relationship between energy and altitude also depends on the ballistic parameters, thus providing data for determining the radiation emitted by a given target and making possible to determine its weight, shape and surface characteristics in terms of the radiation it emits. The intensity of the radiation is a measure indicator of the target's mass, the frequency distribution describes the shape of the target, and spectral analysis can be used to determine the chemical composition of its surface. All of these factors provide target analysis information and lay the groundwork for target recognition.

In order to solve difficult target recognition problems and recognize true and false targets more effectively, all countries involved are doing energetic work on new recognition techniques such as infrared sensing techniques, ABM onboard

recognition radars, television recognition and the like. It is reported that long-wave infrared sensing systems now under development can be used for radiation determination during the reentry and middle stage of target trajectories. In this technique, different optical wavelengths are used to determine target characteristics and recognize targets.

A typical target cluster generally includes decoys, chaff, remnants of the booster rocket and reentry vehicle. Long-wave infrared sensors are used to make measurements on the entire target cluster and determine its "brightness" in different infrared spectral regions, making it possible to calculate the target's temperature and relevant parameters. The change in brightness over time can be used to indicate target temperature variation during the reentry stage. Because decoys, chaff, remnants of the booster rocket and the reentry vehicle differ in size and shape, their temperature change will show clear differences, and by comparing them with measurements for known objects it is possible to recognize unknown objects (true and false targets).

8480

CSO: 4005/802

END