

287017

JPRS 81730

9 September 1982

19980916 080

# East Europe Report

SCIENTIFIC AFFAIRS

No. 753

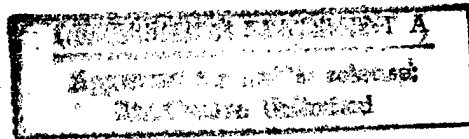

**FBIS**

FOREIGN BROADCAST INFORMATION SERVICE

REPRODUCED BY  
NATIONAL TECHNICAL  
INFORMATION SERVICE  
U.S. DEPARTMENT OF COMMERCE  
SPRINGFIELD, VA. 22161

9  
33  
A03

#### NOTE

JPRS publications contain information primarily from foreign newspapers, periodicals and books, but also from news agency transmissions and broadcasts. Materials from foreign-language sources are translated; those from English-language sources are transcribed or reprinted, with the original phrasing and other characteristics retained.

Headlines, editorial reports, and material enclosed in brackets [] are supplied by JPRS. Processing indicators such as [Text] or [Excerpt] in the first line of each item, or following the last line of a brief, indicate how the original information was processed. Where no processing indicator is given, the information was summarized or extracted.

Unfamiliar names rendered phonetically or transliterated are enclosed in parentheses. Words or names preceded by a question mark and enclosed in parentheses were not clear in the original but have been supplied as appropriate in context. Other unattributed parenthetical notes within the body of an item originate with the source. Times within items are as given by source.

The contents of this publication in no way represent the policies, views or attitudes of the U.S. Government.

#### PROCUREMENT OF PUBLICATIONS

JPRS publications may be ordered from the National Technical Information Service, Springfield, Virginia 22161. In ordering, it is recommended that the JPRS number, title, date and author, if applicable, of publication be cited.

Current JPRS publications are announced in Government Reports Announcements issued semi-monthly by the National Technical Information Service, and are listed in the Monthly Catalog of U.S. Government Publications issued by the Superintendent of Documents, U.S. Government Printing Office, Washington, D.C. 20402.

Correspondence pertaining to matters other than procurement may be addressed to Joint Publications Research Service, 1000 North Glebe Road, Arlington, Virginia 22201.

# EAST EUROPE REPORT SCIENTIFIC AFFAIRS

No. 753

## CONTENTS

### INTERNATIONAL AFFAIRS

Current Scientific Developments Outlined  
(PRZEGLAD TECHNICZNY, 13 Jun 82; RZECZPOSPOLITA, 11 May 82) 1

Plasma Physics, Laser Micro-Fusion  
Radioactive Isotope Production

ERRATUM: In JPRS 81500 10 August 1982 No 751 of this series in article CSSR-USSR COOPERATION IN AGRICULTURAL SCIENCE AND TECHNOLOGY, p 10 para 1 lines 2-3 sentence beginning "In the..." should read "In the meantime CSSR offered the Soviet institute their method of "fertilizing with liquid pig manure."

### CZECHOSLOVAKIA

College Computer Network System Described  
(Jiri Navratil; PTT REVUE, No 3,1982) ..... 8

Developments in Robotronics Described  
(Julius Uhrin; PRACA, 25 May 82) ..... 14

### HUNGARY

Coordination of International Social Science Relations Mandated  
(AKADEMIAI KOZLONY, 19 Jul 82) ..... 21

Science Policy Committee Rules on R&D Development Program  
(AKADEMIAI KOZLONY, 19 Jul 82) ..... 23

Science Policy Committee Stand on Research Training, Scientists' Qualification  
(AKADEMIAI KOZLONY, 19 Jul 82) ..... 26

CURRENT SCIENTIFIC DEVELOPMENTS OUTLINED

Plasma Physics, Laser Micro-Fusion

Warsaw PRZEGLAD TECHNICZNY in Polish No 1, 13 Jun 82

[Interview with Docent (doctor of engineering) Slawomir Denus, director of the Sylvestor Kalinski Institute of Plasma and Laser Microfusion Physics in Warsaw, by Mieczyslaw Lomuda; date and place not specified]

[Question] Professor Basov in the USSR, Dawson in the United States and Professor Kalinski in Poland. Two scientific superpowers and a medium size country. Is not Poland's interest in thermonuclear reactors an example of megalomania?

[Answer] Of course, the dominance of research potential by the big powers is unquestioned. None the less, the field of plasma physics research is so broad that even the big powers cannot resolve all the problems. After all, such research was initiated by England, France and the FRG and later Japan. Poland became involved in lasermicrofusion in 1968, the sixth country in the world to do so.

[Question] Fusion achieved with the aid of lasers is but one of the ways to obtain a common goal--a controlled thermonuclear reaction. Why just lasers?

[Answer] In reality a large number of scholars in the world are concerned with generating and investigating plasmas in magnetic traps. These are closed traps of the TOKAMAK type as well as open traps, linear. These various paths lead to a common goal--the generation of thermonuclear energy, the energy that is released when individual nuclei of deuterium and tritium are combined into a nucleus of helium with the simultaneous emission of a neutron. Unfortunately, this is not an avalanche process; it is very difficult to achieve a self-sustaining effect. In TOKAMAKS--generally speaking, in all magnetic systems--the plasma must be generated and maintained for about one second and even tens of seconds in reactor systems. This is very difficult because the plasma subsists for a relatively short period with a tendency toward instability. To date, these instabilities have not been overcome successfully. By eliminating one and increasing plasma parameters, we generate others for which, unfortunately, there is no unequivocal formula. This is actually why other competing methods have appeared, the so-called inertial maintenance methods.

They boil down to this: a small ball of material (0.1 to 1 mm in diameter) from material which will fuse thermonuclearly in a sudden, collision-type way, is heated from the outside in a spherical, symmetrical system. The intense surface heating and vaporization of part of the material cause the rest of the material to accelerate rapidly toward the center and to compress and heat rapidly in the final phase. This is sufficient to initiate a thermonuclear reaction. These methods are interesting in that they do not require the construction of large and very costly installations to generate a magnetic field. In general, magnetic fields do not appear in them. However, the need to supply energy quickly causes problems. Time periods on the order of several billionths of a second come into play here. But the plasma life time is so short that the most formidable plasma instabilities do not develop. Somehow we outsmart the plasma, disallowing the generation of instabilities. Micro-balls can be heated not only by laser beams but also by electron and ion beams. In Poland the technology of building lasers was mastered at the end of the 1960's at the WAT [Military Technical Academy]. This determined the method selected. Today we use a four-beam laser, an instrument that was built during 1975-1978. With it we illuminate a ball symmetrically from all four sides; this is the minimum number of beams which enables a spherical microfusion experiment to be realized. To achieve laser compression, about  $10^{14}$  W/cm<sup>2</sup> of power are essential. The energy is on the order of 100 J and is sufficient to investigate the effectiveness of laser radiation adsorption as well as the heating and compression of the microsphere.

[Question] In what way do you believe the thermonuclear reaction really occurred?

[Answer] The emission of neutrons is the universal method used to ascertain if a thermonuclear reaction is occurring. During the reaction of a deuterium nucleus with another deuterium nucleus as well as during the reaction time of a deuterium nucleus with a tritium nucleus, that is in the two basic methods of realizing a thermonuclear fusion reaction, a neutron is emitted. The energy of a neutron is 2.45 Mev for a deuterium-deuterium reaction and 14 Mev for a deuterium-tritium reaction. Thus it carries the information that a thermonuclear reaction is occurring in a plasma. The number of neutrons is an indication of the intensity of the reaction. Fortunately, neutrons are very penetrating and can be easily recorded.

[Question] Speaking bombastically, when did the first thermonuclear reaction occur on Polish soil?

[Answer] The first such reaction was achieved in 1973, a short time after we initiated our activity. This was achieved through the great efforts of the entire team and the direct participation of Professor Kalinski. We achieved the effect with the aid of a single-beam laser which was used to irradiate deuterium exchanged polyethylene targets and lithium deuteride. These targets were prepared at the institute.

[Question] What happened after that, in the last 10 years?

[Answer] We started with a diagnostic base that was quite poor. We had equipment which enabled us to record the effects of a fusion reaction but not all the phenomena occurring in a plasma. Nonetheless, the successes were significant. In 1974 the team was awarded the Class I State Award. In the years that followed, above all we built increasingly powerful lasers, developed new diagnostic equipment and conducted research in the physics of plasmas, preparing a scientific cadre for the institute's needs. A two-beam laser was built and then a neodymium four-beam laser. In 1978 we decided that the technical base in the area of neodymium laser is the limit of the institute's and Poland's capabilities, and thus we would not build a larger-power installation. In the final analysis, these are very costly projects. However, we began to construct carbon dioxide (CO<sub>2</sub>) lasers which are much cheaper.

We placed great emphasis on building and improving diagnostic equipment. Right now the institute's diagnostic potential is its greatest potential. These include: a large fan, auxiliary lasers, interferometer systems, refined methods for measuring temperature using X-rays, methods for detailed investigations of plasma dispersion after compression, ultrafast cameras with image convertors and spectrometers with time expansion. This developed equipment permits us to conduct interesting research the results of which have been presented at many international conferences.

[Question] You established cooperation with the USSR....

[Answer] Cooperation began in 1972 at the USSR's initiative, specifically Nobel Laureate Oprof Nikolay Genodevich Basov. The goals of the cooperation were defined precisely in 1974 when a 5-year cooperation plan was prepared. This plan was incorporated into the plan of cooperation between the USSR Academy of Sciences and the PAN [Polish Academy of Sciences]. In the framework of this plan, joint research has been conducted which contributed to our present award.

[Question] What was the award granted for specifically?

[Answer] For work executed jointly with the P.N. Lebedev Institute in Moscow. Our institute developed a set of apparatus for ion diagnosis consisting of a Thompson-type ion mass and energy analyzer, an electrostatic ion analyzer, a set of various types of ion collectors and nitrogen lasers to probe thick plasma layers. The apparatus was designated for common measurements in a 10-beam Kalmar-type laser system. With the aid of this equipment, very basic and conclusive measurements of many new elements in the investigation of plasma compression were made.

[Question] Now much did this research contribute to the knowledge of the processes occurring in a plasma?

[Answer] the joint research was the foundation for designing larger research installations. The system in which the research was conducted has an energy of several hundred Joules in the impulse. However, the research results are conclusive for higher-energy experiments. Higher energy experiments are

contemplated only by three countries: the USSR, the United States and Japan. It is not known if Japan will decide for extreme energy and perform what we call the breakeven experiment.

[Question] Are you considering further cooperation with the USSR?

[Answer] A system having a greater impulse energy has been built in the Soviet Union, and subsequent versions are in preparation for even larger experiments. The Soviets intend to involve us in research on a larger scale because, among other things, we have much experience and the appropriate potential to conduct diagnostic research of plasma.

[Question] Are other socialist countries also participating in this work?

[Answer] Microfusion is being realized only in the USSR. But TOKAMAK type magnetic traps are being realized by the USSR with the limited cooperation of Hungary, Czechoslovakia and Bulgaria. However, these are non-laser methods, and these countries have not acquired a very extensive segment of the diagnostic methods.

[Question] On your opinion, which of these methods auger the greatest hope?

[Answer] I believe that today the experts of the world have no one answer to this question. The very fact that all the laboratories in the world are aiming toward a common goal using various methods is proof that at this time none of them is acknowledged as the sole method presaging success. In countries which cannot afford it, the decision makers undertake risks backing this or that method. The countries which can afford it--the United States and the USSR--support all methods.

[Question] When will we build the first thermonuclear reactor--we, civilization, of course?

[Answer] Basic unknowns exist which make that very difficult to forecast. The problem is that one cannot theoretically forecast all the phenomena that are occurring in a plasma vis-a-vis when increasing energy, the size of the equipment or increasing the power supplied to a core. That is why it is necessary to conduct experiments on an increasingly larger scale. Thus, the step-by-step strategy has been accepted. There is certainty in the state of knowledge and state of technology which permits prognoses one step ahead. Experiments at a higher energy level must be conducted next. But even with the step method, not all theoretical forecasts prove true. It happens that theory presents a pessimistic picture, but because of the nonlinear character of the phenomena with which we have to deal with, the experimental results are better. It turns out that nature does not want to realize all the mischief predicted by theory. But only after an experiment is conducted on a larger scale do certain plasma characteristics appear which in general were not predicted by theory.

However, the more far-reaching prognoses are optimistic. Optimistic in the sense that thermonuclear fusion will be realized. It is expected that in the 1980's it will be demonstrated that the energy released will be greater than the energy supplied in systems such as the TOKAMAK in the USSR and United States or in Shiva-type laser systems or perhaps even in systems using ion beams.

[Question] Will a thermo-nuclear reactor be built before the end of the century?

[Answer] The reactor which will be built and connected into the network will appear only after the need for it has been demonstrated vis-a-vis the world energy crisis, and not earlier. I will explain this. The use of fusion systems, which are not yet contributing energy to the network but can produce nuclear fuel, is a more appropriate technology than thermo-nuclear reactor systems. Analyses conducted by some teams show that nuclear power plants, which make a significant contribution to energy production in the 1990's, have a natural fuel supply for only about 30 years. Even spreading out the construction of such power plants are planned so that the nuclear fuel would suffice for a longer period. Then the uranium crisis will appear. Beyond that, the only possibility of producing nuclear fuel offered by nature is the use of fast neutrons. Such fast neutrons are produced on a large scale precisely by thermonuclear systems. However, I would like to emphasize strongly that they will not be systems producing energy for the network. They can have a coefficient of efficiency less than one, even a lot less. Theoretical calculations indicate that a thermonuclear reaction in TOKAMAK and laser systems as well as in plasma-focus systems produce just enough neutrons so that these neutrons will be captured by natural uranium-238, the dominant (over 90 percent) isotope of uranium ore, and which today represents a waste product of fuel produced for nuclear power plants. This uranium can be converted into plutonium. A single laser microfusion system or any other kind of system generating neutrons at a level of  $10^{16}$  neutrons per impulse will be able to produce fuel for five to six nuclear power plants.

[Question] Much hope is being placed in breeder reactors.

[Answer] Breeder reactors fall somewhat short of our hopes. Their characteristics are such that a single breeder reactor can produce fuel for itself and about 0.6 for the next breeder reactor. On the other hand, one quasi thermo-nuclear system can produce fuel for 5 and, according to some, even for 12 nuclear reactors. In the latter case, we could delay the uranium crisis 100 to 150 years.

[Question] We bought time to develop a thermo-nuclear power plant.

[Answer] If we want to build a nuclear power plant knowing that these electric power plants will have fuel for only about 30 years, then we must start developing fusion systems today. We must think about initiating the first such system in a couple of years. Thus, not much time remains.

It may finally turn out that in the near future we will not want to reach the thermo-nuclear reactor level as an independent source of energy, that we will be satisfied with having a cheap auxiliary system to produce fuel for nuclear reactors.

I believe that under these circumstances the technology of laser microfusion is very suitable. Here plasma is generated in small volume and, in association with this, there is a possibility of very intensive  $U^{239}$  irradiation.

One can liken it to a source of neutrons. A nuclear fuel production system can be relatively small. A 2 to 3 m diameter chamber is sufficient. Plasma-focus type systems are also very efficient and relatively cheap sources of fusion neutrons. They also will be used in hybrid systems to produce nuclear fuel. Our institute, in collaboration with the Institute of Nuclear Research in Swierk, is conducting plasma research in this type systems, which represent a scientific research direction independent of laser microfusion.

[Question] Thus, it is not megalomania, but an integral concrete economic strategy.

[Answer] I believe that at Poland's present stage the most important thing is to maintain a proper potential of knowledge and technology. It takes 10 to 12 years to train a team capable of doing this type work. It is important that when the time comes that we have the capability of building hybrid systems (production of fuel by the laser microfusion method plus a nuclear reactor burning this fuel) then we should take part in it. Of course, above all, those who are knowledgeable in this area will have access to this technology.

[Question] Fortune favors those who are prepared.

[Answer] Today that preparation is our greatest capital.

For the first time the PAN and the USSR Academy of Sciences won an award for exceptional joint scientific achievements resulting from the cooperation between both academies. These awards are given once every 3 years, on the anniversary of the signing of the agreement on scientific cooperation between the PAN and the USSR Academy of Sciences.

Among other things, this year's award was for the development of a method to diagnose and investigate thermonuclear targets heated and compressed with the aid of a laser. Included in the team winning the award are: Docent Dr Slavomir Denus, Dr Jerzy Wolowski, Magister Jozef Farny and Magister Eugeniusz Woryna of the Institute of Plasma and Laser Microfusion Physics and their colleagues from the USSR Academy of Sciences Institute of Physics: Dr Gleb Sklizkov, Dr Andriey Shiknov, Juriy Zakharenkov, candidate of mathematical-physical sciences, and Engineer Aleksiej Jerokhin.

#### Radioactive Isotope Production

Warsaw RZECZPOSPOLITA in Polish 11 May 82 p 5

[Article: "Isotopes for Industry"]

[Text] The Center for the Production and Distribution of Isotopes of the Institute of Nuclear Research in Dwierk is the sole producer of radioactive isotopes in Poland. Radioactive substances used by industry and others are obtained by irradiating so-called target materials in Ewa reactors and partly in the Maria reactor.

Sources of iridium-192 (its production completely satisfies domestic demand, and 30-40 percent is designated for export) and yttrium-169 are used in industrial radiography and flaw detection. Sources of cobalt-60, cesium-137, europium-152 and 154, and strontium 90 are employed in devices that utilize scattering and ionizing radiation phenomena, in isotope relays, level gauges, thickness gauges and in conveyor scales.

A large portion of the production and sources of isotopic smoke detectors. The technology of their production is based on depositing a radioactive glaze containing plutonium-239 on an aluminum base.

11899

CSO: 2602/22

## COLLEGE COMPUTER NETWORK SYSTEM DESCRIBED

Prague PTT REVUE in Czech No 3, 82 pp 73-75

[Article by Engr Jiri Navratil, Advanced School Regional Computer Center:  
"Terminal Network of Advanced Schools Regional Computer Center"]

[Text] The use of computers has a tradition of many years of standing in organizations under the jurisdiction of the Ministry of Education. However, for many years the level of their technical facilities was average or rather below average. A sudden qualitative change was brought about only when the ICL 4-72 computer was installed in 1976.

The computer system, which is available to users from the department of education at the OVC VS [Advanced Schools Regional Computer Center], consists of a ICL 4-72 central computer with one M bytes of operational memory and 600 M bits of disk memory, four ICL 2904 computers (each with 64 K words of operational memory and summary disk capacity of 290 M bits) and additional (peripheral) equipment. It represents not only the most efficient computer system in the department, but is also one of the largest installations in all of of the CSSR. The computer system forms a comprehensive terminal network with more than 50 terminals, in which ICL 2904 computers are connected as satellite computation means (efficient intelligent terminals) of the central system. Each computer in the network has its own network of interactive terminals. The central computer has been in operation for several years in three shifts, and the terminal network is available to the users more than 12 hours daily.

The installation of the system has not only brought about a sudden qualitative change in the work of programmers, but the system makes it possible to process extensive program sets which so far the users in the department have not been able to process, and it provides new opportunities, which can be utilized especially in the area of science and pedagogics.

The conditions under the jurisdiction of the Ministry of Education are rather different from those under the other ministries. While in most computer systems operating in industry or in the central administration, the work concentrates mostly on the ASR [automated management system], the computer system under the Ministry of Education must take care first of all of the areas of pedagogics, scientific research, and also of the ASR area. Each of these areas has its specific characteristics, which have to be taken into

consideration in forming a balanced relationship between the needs and requirements of the users and the capabilities of the system.

For the time being, the most significant users who are making an intensive use of the computer system of the OVC VS are workers from nine advanced schools in the entire CSSR. On the average they use 83 percent of the capacity of the machinery in terms of time, generally in dealing with the tasks of the state plan of basic research

The problems which are handled here are very broad and cover practically all areas of our lives, ranging from agricultural research studies (VSZ [Agricultural College] in Prague) through economic issues (VSE [College of Economics] in Prague), technical areas (CVUT [Czech Institute of Technology] in Prague), VUT [Institute of Technology] in Brno, VSDS [College of Transportation Services (or Systems?) in Zilina), chemistry (VSCHT [College of Chemical Technology] in Prague and Pardubice), all the way to nuclear physics (UK [Charles University] in Prague). During 1981, for example, the computer system dealt with more than 200 research tasks of the state plan, many of them in cooperation with foreign partners, especially Soviet partners (SUMV [Soviet Nuclear Research Institute] in Dubna, USSR Academy of Sciences, TU [Technical University] in Dresden, and so on).

The remaining two areas are not so clearly defined. In the pedagogical area, the bulk of basic courses of student programming involves the use of computers of individual schools, while the OVD VS deals only with specialized services, especially in those fields which are oriented to computer engineering and informatics. The ASR area is still in its beginning in organizations under the jurisdiction of the CSR Ministry of Education, but during the forthcoming years these tasks are also expected to show a major increase.

One of the basic problems of effective utilization of computers is their great imbalance between the speeds of their electronic and mechanical parts. Thus commercial computer installations operating without multiple access, which means without numerous terminals, actually have their computation capacity dependent to some extent on the passage capacity of the classic input and output peripheries. A tremendous amount of data is continuously passing through relatively slow peripheries of the system (scanners of paper media and the printers), which puts a heavy load not only on the system but also on the service personnel. Most of these problems disappear when a terminal network and a sufficiently large disk memory is used. Each user of the terminals has an area in the disk memory allocated to him. He keeps his data and programs there, and by giving a simple instruction he can start at any time to release even several programs, check the flow of their computations, intervene in the computation process or stop it, and then print the output sets only when everything is in order. These questions come up especially during fine tuning of new programs, when errors occur frequently either during compilations, or when logic errors are made during trial runs. Direct contact of the programmer with the computer not only results in savings of all the means of the system, but also makes his own work more effective. The time of preparing a new program is reduced several times when interactive contact is used as compared to the standard dosage method.

The advantages of the systems using time participation in their operations are clearly apparent to everybody today, but of course this processing method also has its pitfalls. The computer system is being given to a certain extent for free use by those users whose requirements are made quite incidentally, and the size of their assignments also vary. Consequently the users may sometimes create a critical situation, when the system becomes heavily loaded, and the service personnel must deal with it immediately. This naturally increases demands in terms of quality of the personnel servicing such a computer system, and to a certain extent it also changes all standard organizational diagrams. A few operational data will perhaps provide the best way of drawing a complete picture of the entire problem.

The central computer of the computer system of the OVC VS processes more than 1,800 assignments daily, and more than 95 percent of these start at the terminals. In addition to the fact that the terminals make it possible to start running the assignments, each operational system which provides multiple access also offer a number of other opportunities to prepare its own data and programs for further processing. This function is also taken care of in the Multijob operational system. It means in practical terms that the user can form from the terminal new sets of data, check them, correct them, print them, cancel them, and so on, all this by merely giving the so-called terminal orders. These orders actually constitute the basic communication language between the user and the operational system. The user has 49 of them at his disposal at present. They are effective, as indicated for example by the fact that the users apply in the course of a day about 6,000 sets.

The existing data base of an ICL 4-72 computer contains about 15,000 sets (the existence of the data base is one of the conditions of the existence of a terminal network). The data base was being created gradually, in practice from the time when the computer was put in operation in April 1976. It contains both data as well as programs of the users. More than 7,000 sets with a total capacity of about 240 million symbols are maintained at present on the average for immediate use (on-line) by the users. Also, about 2,000 additional sets (90 M bytes) are constantly available. These constitute the libraries of the system and of the system's frequently used programs.

The remaining sets are kept on tapes and are integrated in the system according to a regular daily plan or at the owner's request.

The data base has naturally an entirely different structure as compared to the data base of some enterprise or departmental institute, where teams of programmers are developing programs for the processing of information coming from a certain area, and other teams of workers are collecting and preparing data for periodic processing.

The data base of the OVC VS kept developing depending on how the computer was used during 6 years of operation. Since the computer was used mostly to deal with scientific and technical tasks coming from a very broad area, and since the computer system serves more than 150 entirely different types (departments of advanced schools, institutes, and laboratories), which represents about 1,000 programmers, the volume of the actual data is

relatively small, while the number of the programs reaches the figure of several thousand. A tremendous number of changes is made continuously because of the existence of the terminal network, and because of the high degree of parallel processing of the assignments. The users operate with several thousand sets daily. The speed of data replacements can be characterized for example by the number of inputs on individual disks, which vary around 90,000 per hour. Since 1976 the terminal operation has increased about 2.4 times, the average frequency of instructions issued from terminals in 1976 was 8.8 instructions per minute, in 1980 it was as many as 21.2 instructions per minute.

Most of the terminals in our network operate as interactive terminals. All of them are equivalent in relation to the system, and only their physical properties determine how efficient they are now and how popular they are.

The most popular and also the most efficient terminals are alphanumerical displays (ICL 7181). It is particularly appropriate to use these terminals in applications where a short time response is required, or where complex texts, tables, or forms are used. Data which are to be used as input for the computer are shown on the screen and at the same time are placed in the balancing memory. This makes it possible not only to maintain optical control, but also to correct the data before they are sent in the computer. In order to make the user's work easier, they are equipped with internal functions which provide for simple editing of the text (insertion, erasure of symbols in any position), and they also have other properties, such as the ability to use different types of print, intermittent light, the so-called protected fields which cannot be transcribed from the keyboard, and so on. Their equivalents are being tested at present experimentally. It was possible to create these equivalents by using a domestic processor SPU 800 and its peripheries.

The teletype (ASR 33) was for a long time the most widely used type of terminal. Each of the almost 20 HP [units] used in the network since 1976 has completed now more than 4,000 operational hours. It is true that this type of terminal was not too popular because it is noisy and slow, but of course its cost was low, and in addition it makes it possible to keep permanent records. This is a valuable feature, especially in those workplaces where it is not possible to get the prints quickly from printing plants (outside of the Prague area). These terminals will now be replaced by domestic SM 7202 terminals, which successfully passed experimental operations tests in 1981.

The most efficient terminals of the system are the four ICL 2904. Each one of them can operate by itself as an independent computer, in addition to being connected with a central computer. From the central viewpoint, these computers are to be used primarily for long distance data transmission, when the volume of the data exceed the capacity of local facilities. Data which are to be transmitted are concentrated first of all in local disk sets. The operators then sends them for processing to the central system. The results are obtained in a similar way from the central system. Each of the ICL 2904 terminals is equipped for this regime with several (4 to 8) simple screen terminals (DDE), which can be used to form local sets. Linear printing machines are used as output equipment. The ICL 2904 system is also equipped with several disk memories, which provide for an adequate memory capacity for the formed sets and for the basic data base for creating a terminal network at this level of the hierarchy.

The terminals are located in advanced schools and institutions of the CSR Ministry of Education. Advanced schools offices in Prague are covered most intensively. Among those located outside of Prague, the first one connected was the Advanced School of Mechanical and Electrotechnical Engineering in Plzen (1976), later on the VSDS in Zilina (1977), and the VUT in Brno (1978). At present, this applies also to the VSB [Mining College] in Ostrava (1980), and the VSCHT [College of Chemical Technology] in Pardubice (1982).

Many interconnected terminals are located on the premises of the advanced schools in Dejvice. They use the local telephone network as connecting lines. The other interconnected terminals located in Prague and other cities use the state telephone network. Most of these connecting lines terminate in EC 8002 modems operating at speeds of 110 or 300 Bd [bauds]. In the area of Dejvice connections are made automatically by dialing the four-digit number of the branch telephone exchange ending with decimal series, and in the case of other terminals (including those outside of Prague) by dialing a public network number ending in a decimal series.

ICL 7181 videoterminals or their equivalents (SPU-800) are usually connected to leased fixed circuits. They operate at a speed of 1200 bytes per second and use 8006/S2 modems.

ICL 2904 computers are located only in offices in Prague at a distance of 0.2 to 10 kilometers from the center of the network. They are connected with the center by fixed-semi-duplex connecting lines of 2,400 b/s terminating in RAGAL-Milgo 2200/24 modems.

The overall structure of the terminal network is shown in the diagram. All terminal means and forms of connection (concentrators, multi-point connectors, and so on), which occur in the network, are shown here at least in a diagrammatic form.

To maintain the optimum level of equipment, the OVC VS is striving to bring about purposeful technical development, which is being gradually carried out with the full understanding of the Ministry of Education and of the CVUT. During the 6 years of existence of the OVC VS, the entire configuration of the computer system has been expanded substantially. The system is being carefully adjusted, so that it can better satisfy the conditions under which it operates, its operational interchangeability has been increased; the work of users has been simplified and made more efficient, and the reliability of the system has been increased. Through active cooperation with domestic and foreign partners, the system has been augmented by adding a whole series of significant program units (compilers, libraries, and application programs), which have enriched the already relatively wide scale of opportunities for data processing in the OVC VS).

FIGURE APPENDIX

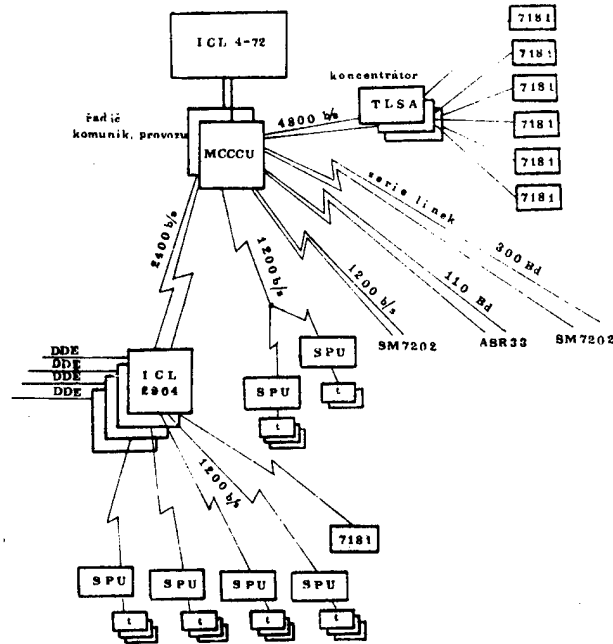

Diagram. Structure of the terminal network of the OVC VS in Prague

- Legend:
- a. Operational communications coordinator
  - b. Series of lines: 300 bauds
  - c. Concentrator

5668  
CSO: 2402/65

DEVELOPMENTS IN ROBOTRONICS DESCRIBED

Bratislava PRACA in Slovak 25 May 82 pp 1, 4

[Article by Eng Julius Uhrin, Deputy Minister of General Engineering: "Development of Robotization in Czechoslovakia"]

[Text] The development of the national economy is imposing steadily increasing demands regarding the development of manufacturing processes, production machinery and equipment, and the mechanization and automation of production and of general engineering.

By introducing automation and robotics we aim to increase the social productivity of labor and the quality and efficiency of production processes and to humanize labor. The last decade has seen the advent of microelectronics, automation and robotics, especially in research, development and testing in both production and nonproduction processes and technologies.

Conception of Automation and Robotization

Automation of manufacturing processes in our plants should be pursued in comprehensive fashion. In addition to automating primary production, we should also automate transport, materials handling, product measurements, tool changing, monitoring and other activities.

Industrial robots and manipulators have an essential role in this process. They create the conditions for successful automation even in small-series and one-off production. They replace human labor in unhealthy or unsafe surroundings. They make it possible to increase the productivity and quality of work. They can function without stopping in three-shift or continuous operation. Robotization of industrial processes is one of the decisive measures planned for the future which will make it possible to introduce automation in machine-building and non-machine-building processes, using the capabilities of industrial robots and manipulators.

Industrial robots are flexibly programmable automatic devices with many degrees of freedom. They tend manufacturing machinery, handling materials during operations and sometimes between operations. They replace humans in the repetitive, monotonous activities of tending machinery.

Industrial robots have been most extensively introduced in machine building. During the Eighth Five-Year Plan they will also enter other sectors. The development of industrial robots is having a fundamental effect on the main areas of development of production machinery, where the trend is toward grouped use of machines in combination with industrial robots and manipulators.

We in Czechoslovakia are now in the initial stage of robotization. Automation of production processes with industrial robots is being pursued over the entire spectrum of research, development, production and use.

The concept for developing robotization is elaborated in State Special Program 07, whose main objective is to expand the automation of production processes by the introduction of industrial robots and manipulators. This requires that at least 4,000 units be produced during the Seventh Five-Year Plan and at least 13,000 by 1990. Their production will require expanded production of electrical, electronic, hydraulic, pneumatic and mechanical parts and assemblies.

The main tasks of the program are:

--by introducing industrial robots and manipulators, to free up at least 55,000 workers and users of this new equipment in 1985;

--to create the main conditions for expanding the range of production processes automated with industrial robots in subsequent five-year plans, achieving major technical, economic and export effects.

The development of robotization in Czechoslovakia will have the following main stages:

--development of a basic standard series of industrial robots and manipulators in the context of state assignments for the development of science and technology during the Sixth and Seventh Five-Year Plans;

--gradual introduction of serial production of robots and manipulators that have been developed, as well as other equipment for in-operation and between-operations handling, during the Seventh Five-Year Plan, so that they can be used to create fully automated manufacturing workplaces;

--development of a production base to produce this equipment;

--test installation of industrial robots and manipulators in selected machine-building and non-machine-building processes to form automated manufacturing workplaces and lines;

--development of adaptive industrial robots and standard-design manipulators, with additions to the standard series in connection with the CEMA robotization program during the Seventh Five-Year Plan;

--development of modular industrial robots, with expanded production of components and modules in cooperation within CEMA during the Eighth Five-Year Plan;

--automation of production processes, using industrial robots and manipulators in both machine-building and non-machine-building processes, by gradually introducing automated manufacturing workplaces, automated production systems, robot production lines and integrated production units during the 1980's and 1990's;

--basic and applied research on components for artificial integration [misprint for "artificial intelligence"] and new, promising structures for production process management supported by organizations within the Czechoslovak Academy of Sciences, the Slovak Academy of Sciences and advanced schools.

#### Preconditions and Problems of the Development of Robotization

Automation is a long-term process of structural transformation of the production base. It must not be approached as a one-effort problem. Technically and economically effective introduction of automation facilities requires that much effort be expended in research, planning and production activities. The decisive criteria for successful introduction of automation and robotization are:

--reliable production operation of automation equipment;

--economically effective production with the new equipment;

--social-societal factors.

Reliability must constantly receive top priority in the technical facilities of all levels involved in development of the new equipment (components base, production equipment), and in all pre-production and production stages of work (research, development, planning, engineering, production and operation of systems). According to our current understanding, the reliability of industrial robots and manipulators depends on the reliability of the production equipment. Most often it is the auxiliary and accessory equipment of workplaces which has the lowest reliability.

The functioning of industrial robots is determined by the reliability and quality of the parts and components used in their production, such as control systems, electric drive components, and hydraulic, pneumatic and other components. In the robot-equipped workplaces put into operation in 1980-81, the control systems are not yet superior to the mechanical and functional components of robots in terms of reliability. In addition to improving the technical quality of mechanized components, it will also be necessary for the electronics industry to make an intensive effort to raise the level of reliability and durability.

In our plants the reliability of automated workplaces is highly dependent on the approach taken to building and maintaining the workplace. Intense

cooperation of users in gradually putting automated workplaces into production is the first precondition for success. For example, excellent results have been achieved by AZNP [Automotive Works National Enterprise] in Mlada Boleslava in the production of aluminum castings by the pressure casting method, using an automated manufacturing workplace consisting of injection presses with an industrial robot. Another example is a machining station at Jihlovane Jihlava. One of the first applications of robots in non-machine-building production has been the hot pipe handling machine at Kavalier Hostomice.

Experience indicates that the greatest effect can be achieved with grouped introduction of industrial robots and manipulators as part of manufacturing complexes and automated lines, sections and shops. The introduction of individual industrial robots is not always effective and is economically costly.

More than 200 automated manufacturing workplaces with industrial robots and manipulators with various levels of function are operating in our industry. Experience shows that their effective introduction depends on suitable choice of manufacturing operations for robot operation and suitable grouping of production equipment into an automatic cycle. In many cases there arises the problem of adapting production machines to automated operation. A critical factor for successful introduction of industrial robots and manipulators is that engineers and management personnel make a positive effort to support all aspects of preparation for the introduction of new equipment, including training personnel sufficiently in advance. It is also necessary to make effective arrangements for all material and technical support of the introduction and operation of automated workplaces so as to achieve the maximum effect.

The first series of industrial robots and manipulators are already being produced. Their prices are high because serial production is just beginning and because the components used in production are costly.

It is also proving necessary to put in intense work on electric and hydraulic drives, electronic control systems and the like so as to solve the problems of achieving optimal technical and economic characteristics.

#### Carrying Out the Assignments

The manager of State Special Program No 07 is the Ministry of General Engineering, which is cooperating closely with the ministries of Technical and Investment Development, Metallurgy and Heavy Engineering, and the Electrical Engineering Industry in the development of robotization. The leading organization for scientific and technical development of industrial robots and manipulators is the Research Institute of the Metals Industry (VUKOV), which is also required to support the program and is coordinating the development of industrial robot production and introduction in Czechoslovakia. Serial production of industrial robots and manipulators has begun in the enterprises ZTS [Heavy Engineering Works] Detva, ZTS Kosice, BAZ [Bratislava Automotive Works] Bratislava, TOS [Machine Tool Plants] Trencin, Trojsmalt Medzev, ZPA [Machinery and Automation Plants] Presov, ZEZ Prague, BEZ [Bratislava

Electrical Engineering Plants] Bratislava, Vyhorlat Snina and Skoda Ostrov nad Ohri. Last year the enterprises produced almost 300 robots and manipulators, which are already in operation at automated manufacturing workplaces. This year the plan calls for production of approximately 650 industrial robots and manipulators and preparation for their introduction in users' facilities. Robot production during the Seventh Five-Year Plan is to use existing production capacities. New facilities will begin to have an effect on output by 1985 and during the Eighth Five-Year Plan.

We are gradually beginning the production of seven types of industrial robots and at least 20 types of manipulators. In addition, we will be further expanding the production of the balancer-type hand-operated manipulators. The types of industrial robots and manipulators in production are intended for tending machine tools and forming machines, for handling sheets of metal, glass or wood, and for arc and resistance welding. The development of robots for surface finishing is being completed. Development work is aimed at developing the next generation of so-called "adaptive" industrial robots and standard-design manipulators. Devices which have been developed thus far are designed for loads of 1 to 125 kg.

The organizations UTK [Central Technical Commission]-SAV [Slovak Academy of Sciences] and VST [Institute of Technology] Kosice have made an important contribution to the development of a standard series of industrial robots and manipulators; they have oriented most of their capacities toward basic research, particularly for next-generation industrial robots. Also an important contributor is VUVT [Research Institute of Computer Technology], Zilina, which provided most of the microprocessor-based control systems.

Introducing industrial robots and manipulators into production requires extensive initiative on the part of industrial enterprises and design and research and development organizations. Programs for introduction of industrial robots and manipulators during 1983-1985 are being developed. Every plant, factory or shop can help in this work by identifying units suited to robotization. Expert analysis of the proposed workplaces is performed and design proposals produced by designated design entities. These are concentrated in VUKOV Presov and in planning organizations such as Projekta, Kovoprojekta, Hutny projekt, INPRO, UTAR, PIZAK and other enterprise organizations for technical design, particularly in the CAZ [Czechoslovak Automotive Works] VHJ and AERO. These organizations also attend to the installation and breaking in of production units for the users.

The development of robotization is imposing new demands to increase the skills of workers, in which specialized schooling may also play a role. Accordingly we must train new specialists for all levels of activity. Specialized advanced-school training oriented towards robotics, robot technology, and industrial robots and manipulators is already being provided by CVUT [Czech Institute of Technology] in Prague, SVST [Slovak Institute of Technology] in Bratislava, VST Kosice and VUT Brno. The skills of engineers and technicians are being upgraded by specialized courses and seminars organized by selected specialized organizations, research institutes and schools in cooperation with groups of specialists in CSVTS [Czechoslovak Scientific and Technical

Society]. Training of specialists to operate, program, maintain and service industrial robots and manipulators has begun at intermediate specialized machine building and electrical engineering schools and technical schools. The basis for systematic work in this area is agreements between the coordinating organization and the individual departments in advanced schools. These forms of education will have to be considerably expanded in coming years as the need increases.

### International Cooperation

Great attention is being devoted to robotization in the Soviet Union, East Germany, Bulgaria and other CEMA countries. International cooperation in research, development and production within CEMA is an effective means of accelerating robotization. Czechoslovakia is included in the multilateral scientific and technical cooperation of the CEMA countries aimed at developing industrial robots and manipulators, as well as control systems and production machinery and lines. We are a party to the agreement on specialization and cooperation in the production of industrial robots signed by the CEMA members.

In 1979 we began joint development of industrial robots with research organizations in the Soviet Union. The first three types of industrial robots, designated AM 5, MTL 10, and UM 160, were successfully developed in 1981. Cooperation has considerably accelerated development and decreased expenditures in the research stage. The jointly-developed types of industrial robots form the basis for export of robots to the Soviet Union during this five-year plan. The effectiveness of future development is being greatly promoted by the concept for the development of robot engineering in the CEMA countries which was approved by the 112th session of the CEMA executive committee. This unified technical concept is based on thoroughly modular design of industrial robots and manipulators. Preconditions include the standardization of modules, assemblies and components of robots, manipulators and auxiliary equipment, and specialization in their production.

Rapid, effective utilization of the newest achievements of science and technology in joint work is the basic precondition for the dynamic development of our advanced socialist society. Achieving the goals that have been set will require an active effort on the part of workers, collectives and especially the operational management of plants, VHJ's and ministries. We expect that the Heavy Machine Works [VTS] VHJ will play a decisive role by creating the conditions for producing welding robots and modular manipulators for machining lines and for building automated workplaces for surface forming. The TST [Engineering Machinery works] VHJ is making a critical contribution to the gradual integration of machine tools and robots into so-called "unattended production machines," which use chiefly special manipulators produced within the VHJ itself. A major task faces the Czech Automobile Plants VHJ, Strojsmalt and PRAGO-UNION, which will be the main users of this equipment and accordingly must develop their own engineering design capacities and prepare to modernize their products and processes. The introduction and mastering of the new equipment offers room for extensive worker initiative.

An example is the enterprises and organizations of the East Slovak Kraj, which in 1980 undertook a joint socialist commitment aimed at speeding up automation and robotization in Czechoslovak industry.

8480

CSO: 2402/54

COORDINATION OF INTERNATIONAL SOCIAL SCIENCE RELATIONS MANDATED

Budapest AKADEMIAI KOZLONY in Hungarian 19 Jul 82 p 100

[Directive No 16/1982 (A. K. 6) MTA-F of the First Secretary of the Hungarian Scientific Academy Concerning the Creation of a Committee to Provide Coordination of International Contacts for the Social Sciences]

[Text] 1.

(1) In agreement with the leaders of the institutions listed in paragraph (3), Section 2, I establish a committee for the coordination of the international contacts of the social sciences.

(2) The Committee is an advisory, reporting organ of the first secretary of the MTA [Hungarian Scientific Academy].

2.

(1) The Committee is designated: Coordination Committee for the International Contacts of the Social Sciences.

(2) The chairman of the Committee is the social sciences deputy first secretary of the MTA.

(3) The members of the Committee are representatives of the presidium of the Hungarian Scientific Academy and its appropriate scientific departments and of the Ministry of Foreign Affairs, the Ministry of Culture, the State Wage and Labor Affairs Office, the Central Statistics Office, the Central Office of the Hungarian Scientific Academy, the National Plan Office, the Political Academy of the MSZMP and the Social Sciences Institute of the Central Committee of the MSZMP.

(4) The chairman of the Committee designates the permanent invited members of the Committee.

(5) The secretariat tasks of the Committee are taken care of by the International Contacts Main Department of the Central Office of the MTA. The chairman of the Committee appoints the Secretary with the agreement of the members of the Committee.

3.

The task of the Committee is to survey the situation of the international contacts of the domestic social sciences and analyse their developmental possibilities and to conduct decision preparing and coordinating activity in regard to:

- (a) international social science research cooperation,
- (b) planning and publishing joint publications,
- (c) preparing Hungarian participation at foreign social science congresses of outstanding significance, and
- (d) preparing the more significant international social science programs to be held in Hungary.

4.

- (1) The sphere of its tasks and detailed rules for its operation must be fixed in the statutes of the Committee. The chairman of the Committee approves the statutes with the agreement of the members of the Committee.
- (2) The statutes of the Committee must be sent to every organ participating in the work of the Committee.

5.

This directive goes into effect on the day of its promulgation.

signed, Lenard Pal

8984

CSO: 2502/86

SCIENCE POLICY COMMITTEE RULES ON R&D DEVELOPMENT PROGRAM

Budapest AKADEMIAI KOZLONY in Hungarian 19 Jul 82 pp 100, 101

[Position of the TPB (Science Policy Committee) Concerning 1981 Execution of the Research and Development Program of the OKKFT (National Medium Range Research and Development Plan) and Concerning Future Tasks]

[Text] 1. The experiences of 1981 confirmed that the programs figuring in the OKKFT can successfully serve:

- development of the economic infrastructure;
- modernization of the production structure and the adopting of new technical cultures; and
- laying a scientific foundation for and further developing our social and economic policy goals.

The programs can help the realization of the national economic goals of the Sixth 5-Year Plan and can contribute to laying the foundations for the economic and social policy goals of the Seventh 5-Year Plan.

2. The research and development programs of the OKKFT will be capable of successfully serving to lay research foundations for our social and economic policy aspirations if:

- initial failures experienced in the course of organizing execution are liquidated as soon as possible;
- one realizes in the course of fulfillment a differentiated guidance practice adjusting flexibly to the character of the programs and putting practical utilization in the center; and
- the responsible authorities carry out without delay and in a determined fashion the tasks which become necessary in the interest of this, that is, hinder the one-sided realization of administrative interests and liquidate the bureaucratic program guidance methods which can be experienced sometimes.

2.1 In the interest of this, the guidance of the programs must be made suitable for taking intervening changes into consideration in time. This requires that:

--the work of the organizations guiding the programs (program councils, program commissioners) should be more worthy and more flexible, adjusting to the character of the programs, and at the same time should be more determined;

--the financing of the programs should be better paced and flexible. We should avoid making the programs too rigid or over-determined by virtue of research and development contracts. We must provide opportunities for the necessary modifications, for abolishing tasks and taking up new ones. At the same time, care must be taken to provide the material cover for tranquil work, ensuring adequate foresight.

2.2 On the basis of experience thus far and in the interest of ensuring success there is a need for significant attitudinal and methodological changes in the case of executing market oriented programs with an immediate economic goal. In the interest of encouraging this:

--the previous one-sided state administrative guidance methods must be replaced by a guidance practice based on the enterprises interested in ultimate utilization of the results, counting more courageously on enterprise independence;

--in connection with the foregoing we should examine how the guidance of the research and development programs connected with central developmental programs might be made more simple, how the unnecessary guidance parallelism might be eliminated;

--in addition, we should examine, in the case of market oriented industrial programs or their sub-programs and in the case of individual projects thereof, how to make better organized the cooperation of various research, producing and marketing organizations, in the interest of the completeness of the innovation process. Special emphasis should be given to realizing the viewpoints of marketing.

2.3 In the case of research and development programs laying the foundations for social and economic policy decisions:

--care must be taken to see that those interested in research work, in defining and executing research goals, debate the conceptions being formed and the research results continuously at appropriate professional forums;

--the authorities responsible for the programs should review the experience thus far in the organization, guidance and research of the programs and should inform the TKB [as published] about this at an appropriate time;

--increased attention should be turned to practical utilization of the research results and recommendations born in the programs;

--it would be well to develop, on the basis of experience, a financing and guidance practice better adjusted to the character of the programs. In accordance with this care must be taken to supplement the guide regulating the direction and financing practice of the OKKFT programs as needed.

3. The practical orientation of the research and development programs of the OKKFT and the need for flexible adjustment to changing requirements justify having those responsible for the programs constantly inform themselves about fulfillment of the programs, taking the necessary action in time. To aid this and on the basis of an earlier resolution of the TPB, supervision of the execution of the programs must be developed further and must be made systematic; there must be continual attention paid to this.

Helping to organize guidance work which treats practical utilization as a central task, shortening the reaction time of guidance, cooperation in reducing the bureaucracy which can be experienced at times and making recommendations for the necessary measures should stand in the center of supervisory and assistance work.

4. The chairman of the OMFb [National Technical Development Committee], the first secretary of the MTA [Hungarian Scientific Academy] and the secretary of the TPB should aid execution of this position with continual organizing, coordinating work.

8984

CSO: 2502/86

SCIENCE POLICY COMMITTEE STAND ON RESEARCH TRAINING, SCIENTISTS' QUALIFICATION

Budapest AKADEMIAI KOZLONY in Hungarian 19 Jul 82 pp 101-103

[Position of the TPB (Science Policy Committee) Concerning Further Development of Researcher Training and Scientific Qualification]

[Text] The Science Policy Committee expresses its appreciation to the work committee examining the possibilities of modernizing scientific qualification. It takes cognizance of the finding of the Committee according to which a sudden, radical change of the system of scientific qualification would not be useful. Defining long term goals, however, is possible; attaining them will require a longer time. The Presidium of the Hungarian Scientific Academy and the Scientific Qualification Committee constantly attend to the experiences of scientific qualification and researcher training and will initiate modifications which become timely. Some of the measures recommended by the work committee can be worked out and implemented in a short time.

1. Taking the foregoing into consideration, the Science Policy Committee is asking the president of the Hungarian Scientific Academy and the chairman of the Scientific Qualification Committee to weigh the recommendations of the committee and make use of the experiences acquired in the course of applying the regulations adopted in 1970 and, in cooperation with the ministers supervising the universities, to submit drafts for new legal regulations for scientific qualification and researcher training. The time limits (for submission to the Science Policy Committee) are:

--September 1982, for a uniform regulation of researcher training, and

--June 1983, for regulation of scientific qualification.

2. The Science Policy Committee offers the following to be taken into consideration in working out the new provisions:

(a) An especially important task at present in the area of scientific researcher training and qualification is a consistent realization of the requirements and, thus, raising the level.

(b) Scientific qualification encourages scientific work, recognizes scientific accomplishment and thus recognizes ability to do scientific work. It is not suitable for the recognition of other merits.

(c) It is especially important and timely to create a uniform system of researcher training by combining the post-graduate scholarship and Scientific Further Training Scholarship system, in accordance with the thinking outlined in the attachment to the Position.

(d) The system of candidate's examinations must be reviewed and, if necessary, changed. In the course of this there must be an increase in the language requirements. The function of the candidate's ideological examination must be clarified, and how it fits into the state regulated system of political training. The substantive requirements of the several tests and the conditions for dispensing with them must be established--keeping in mind the necessity of raising the level.

(e) A dissertation, book, thesis summarizing scientific results or a description of a creation can continue to serve as a basis for awarding scientific degrees.

(f) A principled, consistent fulfillment of the requirements serving as a basis for awarding the degree doctor of sciences must be required. An attempt must be made to raise the scientific level. A study should be made of how to increase the role of scientific bodies in initiating competition for the doctor's degree.

(g) There must be further study of the question of the candidate's and doctor's salary supplement. Prescriptions pertaining to the salary supplement should be fixed by the provisions in a lower level regulation.

3. The Science Policy Committee is asking the minister of culture to review, in cooperation with the minister of agriculture and food and the minister of health affairs, the conditions for awarding the university doctor's title and to initiate the necessary modifications. The TPB offers the following as the chief goal of the review:

--a way to increase the requirements necessary for winning the doctor's title;

--the possibility of introducing a title recognizing initial scientific work at schools awarding the doctor's title together with a university diploma (medical, veterinarian and law schools);

--making uniform the examination requirements and the taking of examinations necessary for winning the doctor's title and the candidate's degree.

The modification should serve to harmonize the requirements constituting the basis for the candidate's degree and the doctor's title and should serve to make the awarding of them uniform in the long run.

Time limit: June 1983.

4. The TPB is asking the first secretary of the Hungarian Scientific Academy to see to the evaluation of the ideas in the conception and, if possible, to their implementation within the framework of the study ordered by TPB resolution 30.009/1981.

5. The Hungarian Scientific Academy and the Scientific Qualification Committee should work out a plan, bringing in the interested supervisory organs, to work out proposals containing the modifications and to prepare for the implementation of the new provisions.

Time limit: July 1982.

Attachment to the Position of the TPB

#### A Conception for a Uniform System of Researcher Training

1. Researcher training is a part of the postgraduate further training of experts with university diplomas. The goal of the training is: to prepare young experts with a knowledge of science and capable of cultivating it who are capable of independent scientific work for modern, high level work in higher education and for practical application of the achievements of science (for developmental work). The success of the further training finds expression in winning the candidate's degree or the university doctor's title. The time of the training is at most 3 years.

2. The training takes place in university or college institutes or faculties and in research institutes suitable for it (hereinafter, research site). The Presidium of the Hungarian Scientific Academy designates at appropriate intervals research sites suitable for the training, taking into consideration the recommendation of the leader of the supervisory organ. The TPB establishes the ratios, by authority or by branch of science, of the scholarship students which can be admitted to the research sites under the supervision of the several authorities.

3. Admission takes place on the basis of a national competition, which is announced by the Scientific Qualification Committee. The application must be submitted to that research site where the applicant seeks training. The research site rank orders the applicants and the Scientific Qualification Committee selects those to be admitted from among those recommended for admission by the research site.

4. Experts younger than 35 years of age, with a university diploma, can compete. Applicants with practical professional experience will have the advantage if they have the same professional level. A study must be made of under what conditions experts graduating from a college may compete.

5. The TMB will establish a work relationship with scientific scholarship students admitted immediately after graduating from a university. Scholarship students already employed, admitted from another place of work, will have no work relationship at their previous place of work during the period of their scholarship. Care must be taken to place people who have participated in training after the completion of their scholarship.

6. Correspondence researcher training must be maintained and expanded. (A study should be made to see if the scholarship or correspondence form of organized researcher training should become the basic path to winning a

candidate's degree). Point 4 in regard to conditions for the competition is the guide for correspondence researcher training also.

7. The present system of foreign researcher training should be maintained and, if possible, expanded; this should be achieved within the framework of interstate agreements and through training at the burden of the foreign institutions.

8. The legal standing of persons participating in domestic researcher training corresponds to the legal standing of scientific assistants; their scholarships should be established uniformly within the wage item for scientific assistants. The enterprise or institution sending them can supplement their scholarship--on the basis of an agreement made with the person on the scholarship.

9. The research site sees to providing conditions for the work of the scholarship students and to scientific guidance and supervision of their work, it being institutionally responsible for the training of the scholarship student. A leader is designated to guide and supervise the individual program of the scholarship student. The organized nature of the training should be increased via special collegia and seminars.

10. In the course of their training the scholarship students take tests corresponding to the candidate's test requirements and prepare their dissertations. The research site responsible for their training (its scientific council or the appropriate university body) decides whether the dissertation should be submitted to win a university doctor's title or a candidate's degree.

11. The following resources should be used for scholarship training:

- the financial frameworks for scientific further training scholarships;
- the financial frameworks available for domestic graduate student scholarships;
- scholarships which can be established by enterprises and institutions.

12. The system for researcher training should be worked out and the preparatory work should be done in such a way that the competition can be posted by December 1982 and that training in the new system can begin in September 1983. Domestic graduate student scholarships for 1983 need not be announced.

8984  
CSO: 2502/86

END