

REPORT DOCUMENTATION PAGE

Form Approved
OMB No. 074-0188

Public reporting burden for this collection of information is estimated to average 1 hour per response, including the time for reviewing instructions, searching existing data sources, gathering and maintaining the data needed, and completing and reviewing this collection of information. Send comments regarding this burden estimate or any other aspect of this collection of information, including suggestions for reducing this burden to Washington Headquarters Services, Directorate for Information Operations and Reports, 1215 Jefferson Davis Highway, Suite 1204, Arlington, VA 22202-4302, and to the Office of Management and Budget, Paperwork Reduction Project (0704-0188), Washington, DC 20503

1. AGENCY USE ONLY (Leave blank)		2. REPORT DATE August 1997	3. REPORT TYPE AND DATES COVERED Ph.D. Thesis	
4. TITLE AND SUBTITLE Ultra-Violet Light/Ozone Treatment of a Sequentially Loaded and Regenerated Granular Activated Carbon			5. FUNDING NUMBERS N/A	
6. AUTHOR(S) James S. Dusenbury				
7. PERFORMING ORGANIZATION NAME(S) AND ADDRESS(ES) Graduate School Pennsylvania State University Dept. of Civil and Environmental Engr.			8. PERFORMING ORGANIZATION REPORT NUMBER N/A	
9. SPONSORING / MONITORING AGENCY NAME(S) AND ADDRESS(ES) SERDP 901 North Stuart St. Suite 303 Arlington, VA 22203			10. SPONSORING / MONITORING AGENCY REPORT NUMBER N/A	
11. SUPPLEMENTARY NOTES This work was supported in part by SERDP. The United States Government has a royalty-free license throughout the world in all copyrightable material contained herein. All other rights are reserved by the copyright owner.				
12a. DISTRIBUTION / AVAILABILITY STATEMENT Approved for public release: distribution is unlimited			12b. DISTRIBUTION CODE A	
<div style="font-size: 2em; font-weight: bold; margin: 0;">19980710 016</div>				
13. ABSTRACT (Maximum 200 Words) The research described herein has evaluated a UV/ozone in-situ regeneration treatment of sequentially loaded and regenerated GAC biofilters used for removing methyl isobutyl ketone (MIBK) from waste-air streams. Exploration has been conducted in the three primary areas of: (a) GAC biofiltration including ultra-violet light (UV)/ozone treatment of sequentially loaded and regenerated GAC biofilters, (b) biofilter biofilm kinetics, and (c) UV/ozone treatment of virgin and loaded GAC. The GAC biofilter was alternately exposed to a simulated waste air stream laden with MIBK for 24 hours, followed by exposure to a regeneration air stream for 24 hours. The second bed was regenerated with either humid air or humid air which had passed through the UV reactor to produce ozone and associated oxidants. Sequentially loaded and regenerated bench-scale reactors have been constructed to operate in a manner analogous to a commercially available air pollution control system manufactured by Terr-aqua Environmental Systems (TAES).				
14. SUBJECT TERMS methyl isobutyl ketone, GAC, biofilter, biofilm, retention time, SERDP			15. NUMBER OF PAGES 163	
			16. PRICE CODE N/A	
17. SECURITY CLASSIFICATION OF REPORT Unclass.	18. SECURITY CLASSIFICATION OF THIS PAGE Unclass.	19. SECURITY CLASSIFICATION OF ABSTRACT Unclass.	20. LIMITATION OF ABSTRACT UL	

NSN 7540-01-280-5500

Standard Form 298 (Rev. 2-89)
Prescribed by ANSI Std. Z39-18
298-102

DTIC QUALITY INSPECTED 1

The Pennsylvania State University
The Graduate School
Department of Civil and Environmental Engineering

**ULTRA-VIOLET LIGHT/OZONE TREATMENT OF A SEQUENTIALLY
LOADED AND REGENERATED GRANULAR ACTIVATED CARBON
BIOMETER**

A Thesis in
Environmental Engineering

by
James S. Dusenbury

Submitted in Partial Fulfillment
of the Requirements
for the Degree of

Doctor of Philosophy

August 1997

We approve the thesis of James S. Dusenbury.

Date of Signature

Fred S. Cannon
Assistant Professor of Environmental Engineering
Thesis Advisor
Chair of Committee

William D. Burgos
Assistant Professor of Environmental Engineering

Brian A. Dempsey
Associate Professor of Environmental Engineering

Robert J. Heinsohn
Professor of Mechanical Engineering

Ming Tien
Professor of Biochemistry

Walter P. Kilariski
Professor of Civil Engineering
Acting Head of the Department of Civil
and Environmental Engineering

ABSTRACT

The research described herein has evaluated a UV/ozone in-situ regeneration treatment of sequentially loaded and regenerated GAC biofilters used for removing methyl isobutyl ketone (MIBK) from waste-air streams. Exploration has been conducted in the three primary areas of: (a) GAC biofiltration including ultra-violet light (UV)/ozone treatment of sequentially loaded and regenerated GAC biofilters, (b) biofilter biofilm kinetics, and (c) UV/ozone treatment of virgin and loaded GAC.

The GAC biofilter was alternately exposed to a simulated waste air stream laden with MIBK for 24 hours, followed by exposure to a regeneration air stream for 24 hours. The second bed was regenerated with either humid air or humid air which had passed through the UV reactor to produce ozone and associated oxidants. Sequentially loaded and regenerated bench-scale reactors have been constructed to operate in a manner analogous to a commercially available air pollution control system manufactured by Terraqua Environmental Systems (TAES).

A maximum removal efficiency of >95% was achieved by the ozonated sequentially loaded and regenerated biofilter using an air retention time of 148 seconds and a influent concentration of 135 ppm MIBK. The air retention time had a larger effect on the removal of contaminants from the waste air stream than did the contaminant concentration. A four fold increase in retention time, from 11 seconds to 44 seconds, led to a more than doubling of the removal efficiency, 18% to 45%, while, a three and a half fold decrease in influent concentration, from 140 ppm to 40 ppm, led to little change in

the GAC biofilter removal efficiency, 45% to 44%, for the unozonated seeded sequentially loaded and regenerated GAC biofilter.

Bio-kinetic parameters were measured using CO₂ generation from a biofilm supported on GAC matrix employing a fed-batch technique. In this method MIBK that was degraded from the air-phase was replenished by desorption from GAC. Haldane-Andrews kinetic parameters were determined by a best fit analysis, giving $k_{max} = 25$ ppm MIBK/hr*g biofilter material, $K_s = 675$ ppm MIBK, and $K_i = 7040$ ppm MIBK. These parameters were then used to estimate MIBK degradation rates. Experimental results for the unozonated seeded GAC biofilter were well described by the model of Ottengraf [1984] using these kinetic parameters.

For MIBK, advanced oxidant desorption/destruction occurred predominantly within the first inch of the GAC bed. The maximum desorption/destruction efficiency of 85% occurred at the influent face of the GAC bed and dropped to 20% at 3-inches into the bed. The remaining portion of the bed also achieved 20% regeneration in a 24 hour run. Roughly 10% of the MIBK was converted to products that contained fewer carbon atoms and more oxygen functional groups.

GAC very effectively captured ozone and associated advanced oxidants from an air stream during initial time periods. A bed of GAC 1/8-inch deep was able to remove over 95% of the initial advanced oxidant concentration from an air stream which was passed through the bed in a 30 minute experimental run.

TABLE OF CONTENTS

		<u>Page</u>
LIST OF FIGURES		viii
Chapter 1	INTRODUCTION AND OBJECTIVES	1
1.1	Introduction	1
1.2	Objectives	5
1.2.1	Fundamental Mechanisms to be Investigated	6
1.3	Manuscript Structure	7
Chapter 2	ADVANCED OXIDANT REACTIVITY PERTAINING TO GRANULAR ACTIVATED CARBON BEDS FOR AIR POLLUTION CONTROL	9
2.1	Abstract	9
2.2	Introduction	10
2.3	Literature Review	12
2.3.1	Granular Activated Carbon	12
2.3.2	Ozone Reactions with GAC	14
2.3.3	Advanced Oxidant Reactions with Organic Compounds	16
2.3.3.1	Reactions with Alkanes	19
2.3.3.2	Reactions with Alkenes	20
2.3.3.3	Reactions with Aromatic Compounds	21
2.4	Materials and Methods	22
2.4.1	Loading and Regeneration Experiments	22
2.4.2	Adsorption Analysis	24
2.4.3	VOC Analysis	25
2.4.4	Ozone and Total Oxidant Penetration Experiments	25
2.5	Results and Discussion	27
2.5.1	Loading and Regeneration Results	27
2.5.2	Ozone and Total Oxidant Penetration Results	31
2.5.2.1	Influence of Humidity, Time, and Bed Depth	32
2.5.2.2	Advanced Oxidant Penetration into VOC-Laden GAC	35
2.6	Summary and Conclusions	37
Chapter 3	BIOFILM BIODEGRADATION KINETICS OF VOLATILE ORGANIC COMPOUNDS IN A GRANULAR ACTIVATED CARBON BIOFILTER	56
3.1	Abstract	56
3.2	Introduction	56
3.3	Literature Review	58

3.3.1	Biofilm Biodegradation Kinetics	58
3.3.2	Biodegradation Kinetics of Biofilms Attached to Adsorbent Materials	61
3.3.3	Determination of Biodegradation Kinetics Through Respirometry	63
3.4	Materials and Methods	65
3.4.1	Biofilm/GAC Matrix Source	65
3.4.2	Experimental System	66
3.4.3	Analytical Procedures	68
3.5	Results and Discussion	69
3.5.1	Biofilm Kinetics for the Unozonated GAC Biofilter Sample	69
3.5.2	Comparison of Unozonated GAC Biofilter Kinetics with the Ozonated Biofilter Sample	73
3.5.3	Estimation of Substrate Utilization Parameters	73
3.6	Summary and Conclusions	74
Chapter 4	EFFECT OF ADVANCED OXIDANTS GENERATED VIA ULTRA-VIOLET LIGHT ON A SEQUENTIALLY LOADED AND REGENERATED GRANULAR ACTIVATED CARBON BIOFILTER	83
4.1	Abstract	83
4.2	Introduction	84
4.3	Literature Review	85
4.3.1	Biological Air Pollution Control Processes	85
4.3.2	Air Biofilters	86
4.3.3	Ozone and Oxidant Treatment of Water Phase Biological GAC	89
4.4	Materials and Methods	90
4.4.1	GAC Biofilter System	90
4.4.2	Determination of Gas Phase Concentrations of MIBK	94
4.4.3	Total Organic Carbon, pH, and GC Analysis of GAC Biofilter Liquid	94
4.4.4	Respirometry Analysis	95
4.5	Results and Discussion	96
4.5.1	Performance of Bioactive Seed GAC	96
4.5.2	GAC Biofilter Removal Efficiency and Rate	98
4.5.3	Ozone Penetration	102
4.5.4	Effluent Concentration From Bed Undergoing Loading Over 24 Hours	103
4.5.5	Biofilter Liquid pH and Total Organic Carbon Concentration	105
4.5.6	Biofilter Response to Changes in Influent concentration	106
4.6	Summary and Conclusions	107

Chapter 5	TREATMENT OF METHYL ISOBUTYL KETONE BY A SEQUENTIALLY LOADED AND REGENERATED GRANULAR ACTIVATED CARBON BIOFILTER	121
5.1	Abstract	121
5.2	Introduction	121
5.3	Literature Review	123
5.3.1	Biological Air Pollution Control Processes	123
5.3.2	Theoretical Modeling and Design of Biofilters	123
5.3.2.1	First Order Kinetics	128
5.3.2.2	Zero Order Kinetics Reaction Limited	130
5.3.2.3	Zero Order Kinetics Diffusion Limited	131
5.4	Materials and Methods	134
5.5	Results and Discussion	134
5.5.1	Sequentially Loaded and Regenerated GAC Biofilter Performance	134
5.5.2	Determination of Model Parameters and Suitability for the Unozonated GAC Biofilter	138
5.5.3	Determination of Model Parameters and Suitability for the Ozonated GAC Biofilter	140
5.6	Summary and Conclusions	141
Chapter 6	SUMMARY AND CONCLUSIONS	148
6.1	Summary	148
6.2	Conclusions	153
6.3	Original Contributions to Science and Engineering	154
	REFERENCES	156
APPENDIX	List of Symbols	162

LIST OF FIGURES

<u>Figure</u>		<u>Page</u>
1-1	Terr-Aqua Enviro Systems	8
2-1.	GAC Bed UV/Ozone Regeneration System	41
2-2	MIBK Mass Transfer Zone in GAC Bed at 35 PPMV	42
2-3	MIBK Mass Transfer Zone in GAC Bed at 325 PPMV	43
2-4	MIBK Mass Transfer Zone in GAC Bed at 12,000 PPMV	44
2-5	UV/O ₃ regeneration Zone in GAC Bed	45
2-6	24 Hour UV/O ₃ Regeneration of GAC Loaded for 24 Hours with 160 PPMV MIBK	46
2-7	Regenerated GAC Extract Chromatogram	47
2-8	Ozone Penetration in 30 Minutes versus Depth into GAC Bed	48
2-9	Humid O ₃ Penetration Versus Time into GAC	49
2-10	Total Advanced Oxidant Penetration Versus Time into a GAC Bed	50
2-11	Humid O ₃ and Total Oxidant Penetration Versus Time Through 1/8-Inch GAC	51
2-12	Humid O ₃ Penetration Versus Time into 1/8-Inch GAC Bed	52
2-13	Humid Air Total Advanced Oxidant Penetration Versus Time into 1/8-Inch GAC Bed	53
2-14	Humid O ₃ Penetration Versus Time into 1/8-Inch GAC Bed	54
2-15	Humid Air Total Advanced Oxidant Penetration Versus Time into 1/8-Inch GAC Bed	55
3-1	Fed-Batch Reactor GAC Biofilter Apparatus	76
3-2	Fed-Batch Reactor CO ₂ Production Versus Time	77

3-3	Fed-Batch Reactor CO ₂ Production Versus Time	78
3-4	Fed-Batch Reactor Air-Phase MIBK Concentration	79
3-5	Fed-Batch Reactor CO ₂ Generation Rates	80
3-6	Fed-Batch Reactor CO ₂ First Order Generation Rate	81
3-7	Fed-Batch Reactor CO ₂ Production for Ozonated and Unozonated GAC Biofilter Samples	82
4-1	Sequentially Loaded and Regenerated Biofilter	109
4-2	Continuos Flow Biofilter Removal Efficiency at 40 ppm MIBK, 22 Second EBCT	110
4-3	Oxygen Uptake for 20 Grams GAC From Continuous Flow Biofilter Loaded at 175 ppm MIBK	111
4-4	Sequential GAC Biofilter Removal Efficiency at 115 ppm MIBK, 11 Second EBCT	112
4-5	Sequential GAC Biofilter Removal Efficiency at 140 ppm MIBK, 44 Second EBCT	113
4-6	Sequential GAC Biofilter Removal Efficiency at 75 ppm MIBK, 44 Second EBCT	114
4-7	Sequential GAC Biofilter Removal Efficiency at 35 ppm MIBK, 44 Second EBCT	115
4-8	Sequential GAC Biofilter Removal Efficiency at 125 ppm MIBK, 148 Second EBCT	116
4-9	Ozone Penetration Through Wet and Dry GAC Beds After 1 Hour	117
4-10	24 Hour Effluent MIBK Concentration From Sequential GAC Biofilter Loaded at 35 ppm	118
4-11	pH of Sequentially Loaded and Regenerated GAC Biofilters	119
4-12	MIBK/Coconut Shell GAC Isotherm	120

5-1	Biophysical Model for Biofilter Biofilm	143
5-2	AO-Regen-Seeded GAC Biofilter Influent and Effluent MIBK Concentrations	144
5-3	Air-Regen-Seeded GAC Biofilter Influent and Effluent Concentrations	145
5-4	Reciprocal Gas Velocity Versus Natural Log of Efficiency	146
5-5	Ottengraf First Order Kinetics Biofilter Removal Efficiency Model	147

CHAPTER 1 INTRODUCTION AND OBJECTIVES

1.1 Introduction

The focus of this study has been an ultra-violet light(UV) /advanced oxidation (AO) in-situ treatment of a sequentially loaded and regenerated granular activated carbon (GAC) biofilter used for removing volatile organic compounds (VOCs) from a contaminated air stream. Advanced oxidants are defined as O_3 and its associated highly reactive intermediates such as, OH^* , HO_2^* , and organic radicals. Experiments have been initiated in this research to define the mechanisms involved in the treatment of a waste air stream contaminated with VOCs via GAC biofiltration and advanced oxidant treatment of the biofilter. Specifically, GAC biofiltration, GAC advanced oxidation regeneration, and advanced oxidant treatment of a GAC biofilter have been investigated. The results of this analysis have provided insight into fundamental concepts of advanced oxidant treatment of a sequentially loaded and regenerated GAC biofilter. This knowledge may be used to model the system and determine the required bed size and operating parameters of the advanced oxidant treated GAC biofilter to achieve pollutant removal that meets air quality standards. This work will also help determine the optimum system/bed configuration and conditions for treatment systems already in operation.

Air emissions have become a major concern in America because of their substantial magnitude. The need for effective air pollution remediation technologies for

industrial facilities is expected to become more critical as emissions of VOCs into the atmosphere become more tightly regulated.

Granular Activated Carbon (GAC) offers a proven and effective technology for capturing VOCs from air emissions [Wark and Warner, 1981; Heinsohn and Kabel, 1995]. The large surface area, microporous structure, and high surface reactivity of GAC provides a very efficient material for the removal of pollutants from contaminated air. However, while in service, the GAC will eventually become exhausted in its capacity to adsorb organic compounds. At this point the GAC must either be discarded or regenerated. If discarded, the landfilled GAC potentially creates a hazardous and solid waste problem. Regeneration is preferred, with thermal regeneration being a common method. However, the drawback with thermal regeneration is that it often requires the removal of the GAC from the system, causing downtime on the equipment and wear on the GAC and equipment. Oxidative thermal regeneration also destroys the GAC within several cycles and requires that make-up carbon be added [Cannon *et al.*, 1994].

For many years, biological degradation of organic compounds has been used as a principal method in the treatment of wastewater. This process employs microorganisms which degrade organic compounds for energy and growth. The contaminated water and microorganisms are brought into contact in a reactor to facilitate mass transfer of organic compounds from the wastewater to the biological mass. Under favorable conditions the microorganisms will convert the organic compounds to CO₂, H₂O, cell material, and energy.

For contaminated air emissions, biological treatment has been used in Europe for a number of years and is gaining recognition in the United States [Bohn, 1992; Hodge *et al*, 1991; Leson and Winer, 1991; Ottengraf 1981, Shareefdeen *et al*, 1993; Prokop and Bohn, 1985]. The concepts of biodegradation and adsorption by solid media have been combined in a process that has been termed biofiltration. In biofiltration, air streams laden with contaminants are passed through a solid media on which microorganisms are immobilized. A number of solid media have been used, including compost, peat, soil, and synthetic packing materials [Leson and Winer, 1991; Ottengraf, 1981]. Another media which has occasionally been used as the solid matrix for supporting microbial activity is GAC [Hodge *et al*, 1991; Ottengraf, 1981]. The combination of GAC and biological activity offers the advantages of both treatment methods. Biological degradation of the VOCs provides a continuous and stable treatment that may lead to complete mineralization of the pollutants. The GAC's ability to rapidly adsorb VOCs, toxic compounds, and strong oxidants, can dampen shock loading on the system and protect the microbial population. The slow desorption of the pollutants from the GAC during periods of reduced loading helps maintain a constant substrate source for the microorganisms.

The Pennsylvania State University Applied Research Laboratory (Penn State ARL) has been researching an advanced oxidation (AO) system that has been installed for controlling volatile organic compounds (VOCs) that are released from paint spray booths in a US Marines maintenance center. After exhaust air from industrial operations is introduced into the system, the air first passes through a mechanical filter to remove large

particulate matter (Figure 1-1). Then the air flows through a pre-oxidation chamber (preox) containing UV lamps. The next phase of the treatment is a mist air dispersion unit (MAD) where the exhaust passes through a fine mist of water. Exhaust air then passes sequentially through an air/water packed stripping tower, where some air-phase VOCs transfer to the water-phase, then an air-phase photolytic chamber, and then through GAC beds. The work herein pertains to the GAC beds and AO regeneration of these beds. The commercial system includes two GAC beds. At any given time, one of these beds adsorbs VOCs while the other becomes regenerated with advanced oxidants at near-ambient temperatures. After the regeneration process the exhaust stream returns to the system headwork's. The two beds cycle from adsorption mode to regeneration mode at daily intervals.

This multi-component system has been manufactured and commercially installed by Terr-Aqua Environmental Systems (TAES) of Fontana, CA. The systems have controlled the VOCs from 12 industries that together exhaust 0.5 million cubic feet per minute (cfm) of air. The manufacturer of these systems reported that they have complied for seven years with emission standards of the California South Coast District, one of the most stringent in America. Compliance has been reported while the GAC has been cyclically regenerated with AO at ambient temperatures, and the TAES operators have never seen a need to replace the GAC in their California systems. The Penn State ARL role, as funded through the Strategic Environmental Research and Development Program (SERDP) and the Augmentation Award for Science and Engineering Research Training

(AASERT), has been to improve this system's efficiency via fundamental research so that it can be more cost effective.

In laboratory experiments that were designed in a manner analogous to field conditions, a packed bed of virgin coconut GAC was loaded with methyl isobutyl ketone (MIBK). MIBK was chosen as a representative VOC since it is a common solvent in industrial coating operations and it has been of particular importance to the Marine Corps. Based on a survey of common solvents, this compound was anticipated to be one of the more difficult to control during the initial stages of the treatment system, and it would therefore reach the GAC bed in significant quantities.

1.2 Objectives

The intent of this research may be broken down into two principal goals. The first goal was to investigate a sequentially loaded and regenerated GAC biofilter system. The system consists of two columns of GAC which serve as a matrix for microbial activity. One of the columns treated an air stream laden with VOCs while the second was regenerated humid air. The operation of the two columns was periodically reversed. This exploration included examining both the physical/chemical and biological aspects unique to this method of operation. These mechanisms were then used to explain how this treatment process generated VOC removal efficiencies of greater than 95% from contaminated air streams. Secondly, this work aimed to evaluate the effect of using advanced oxidants generated via an ultra-violet lamp reactor as a regeneration treatment

for the GAC biofilter. Specifically, the aim was to determine if the ozone and associated advanced oxidants induce degradation and/or enhanced desorption of the VOC adsorbed in the GAC biofilter, therefore, increasing biodegradation rates within the filter.

1.2.1 FUNDAMENTAL MECHANISMS TO BE INVESTIGATED:

1. Determine the overall system reaction mechanism and kinetics by evaluating the system treatment efficiency and VOC degradation rate, at various mass loading rates, flow rates, and influent concentrations for conditions representative of full-scale applications for the following systems: (a) non-ozonated virgin GAC biofilter (*air-regen-unseeded* biofilter); (b) non-ozonated biologically seeded GAC biofilter (*air-regen-seeded* biofilter); and (c) an ozonated biologically seeded GAC biofilter (*AO-regen-seeded* biofilter).
2. Develop a method to determine the microbial kinetics within the biofilter biofilm. Use the method to evaluate the biofilm kinetics for the *AO-regen-seeded* and *air-regen-seeded* biofilters.
3. Evaluate the GAC adsorption mechanism for MIBK in the air phase. Integrate the GAC adsorptive mechanisms with the biological degradation kinetics to develop a more complete understanding of the GAC biofilter.
4. Investigate the reactions of ozone with selected VOCs and GAC to determine the reaction mechanisms responsible for the enhanced treatment of VOCs via the *AO-regen-seeded* GAC biofilter.

5. Apply insight into the mechanisms and kinetics of the system to determine if any of the biofilter models currently proposed are an adequate representation of the sequentially loaded and regenerated GAC biofilter systems investigated herein. The data will then be used to develop the appropriate parameters for the model for the *air-regen-seeded* biofilter and define any modifications necessary. The *AO-regen-seeded* system will then be modeled in the same manner as the *air-regen-seeded* systems to evaluate if the model is appropriate for the system receiving advanced oxidant treatment.

On the basis of these research findings, the aim was to then enhance the operation and design of full-scale GAC biofilter systems to improve the efficiency and create a more cost effective system.

1.3 Manuscript Structure

The First Chapter is a general introduction, including research objectives. Chapters 2 - 5 cover separate topics and were structured as journal articles. Each of the chapters 2-5 proceed in the following manner; abstract, introduction, literature review, materials and methods, results and discussion, and conclusions. Chapter 2 has been published in *Carbon* 34(12):1577 - 1589, 1996. Chapter 6 is a summary and conclusions of the entire research.

Figure 1-1: Terr-Aqua Enviro Systems

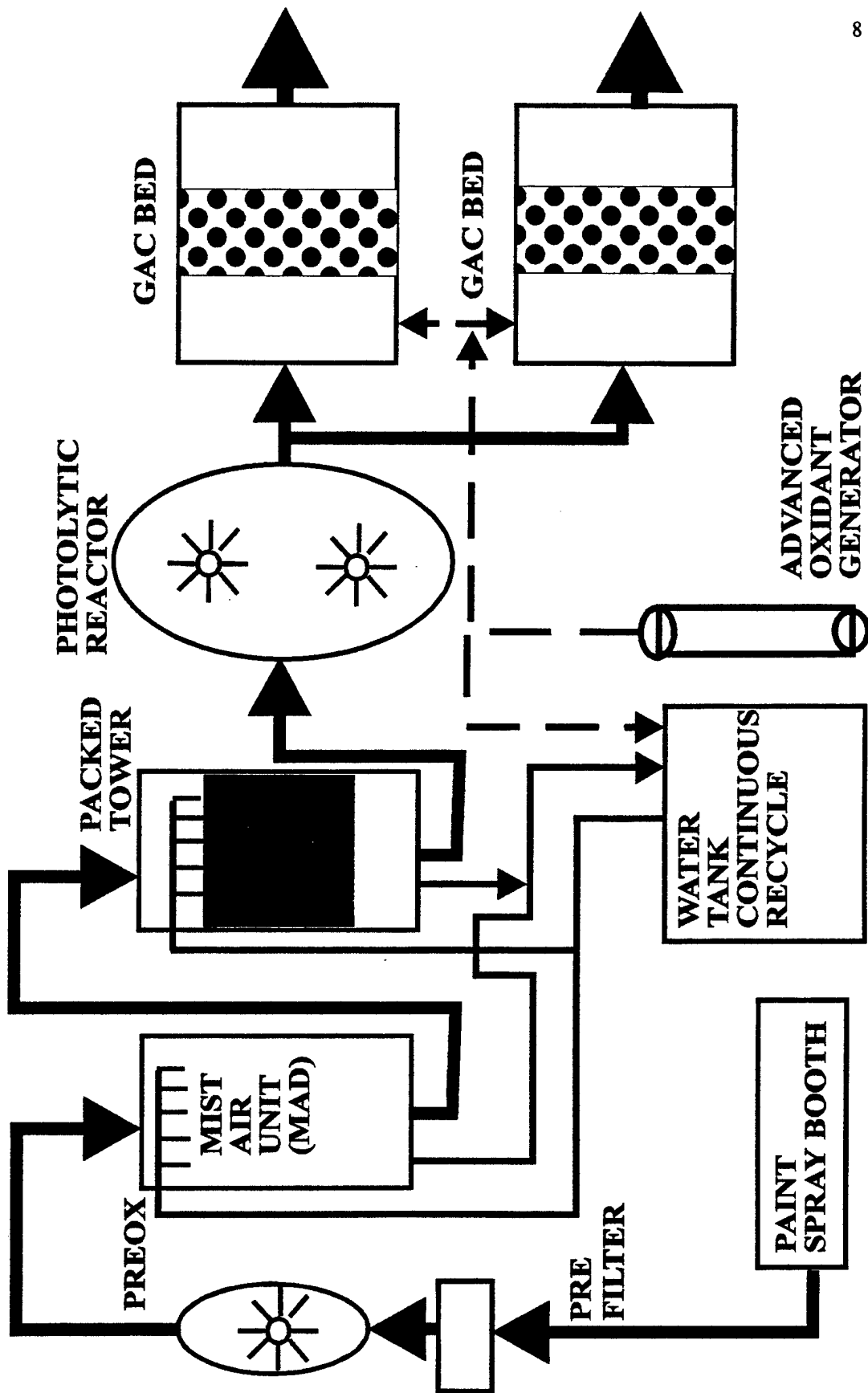

CHAPTER 2
ADVANCED OXIDANT REACTIVITY PERTAINING TO GRANULAR
ACTIVATED CARBON BEDS FOR AIR POLLUTION CONTROL
(Published in *Carbon* 34(12):1577 - 1589, 1996)

2.1 Abstract

The Pennsylvania State University is researching an advanced oxidation system, which includes an air-phase photolytic chamber, an air/water stripping tower, and granular activated carbon (GAC) beds, for controlling volatile organic compounds (VOCs).

A laboratory-scale experimental procedure has been employed that simulated certain aspects of several full-scale installations. The apparatus has been used to characterize the loading capacity and mass transfer zone of selected VOCs on coconut shell GAC. The GAC bed has then been placed in series with an ultraviolet reactor, which generates ozone and advanced oxidants in order to regenerate the loaded GAC at intensities of advanced oxidants that were higher than full-scale installations.

VOC loading tests revealed that the adsorption of methyl isobutyl ketone (MIBK) was characterized by a well-defined mass transfer zone. Upon exposure to UV/O₃, desorption and/or destruction of the MIBK and other VOCs occurred most prominently within the first inch of the GAC bed. This correlated with the penetration of advanced oxidants into the GAC bed, which also occurred most significantly in the bed's first inch. However, the amount of oxidant penetration increased with time. The removal of oxidants from air by GAC was accompanied by a decrease in mass of the GAC. The

ability of oxidants to penetrate a GAC bed was altered when the bed was loaded with a VOC.

2.2 Introduction

Granular activated carbon (GAC) adsorption offers an efficient technology for removing volatile organic compounds (VOCs) from air pollution sources. The large surface area, extensive microporous structure, and rapid adsorption capability of GAC provide a very effective process for removing pollutants from effluent air streams. However, while in service, the GAC eventually becomes exhausted in its capacity to adsorb organic compounds. At this point the GAC can either be landfilled and replaced, or it can be regenerated and reused. If discarded, the landfilled GAC creates a solid waste problem and it may in certain cases be considered hazardous [Notthakun *et al*, 1993].

Regeneration is preferred and therefore the authors have evaluated advanced oxidation (AO) for regenerating spent GACs that have adsorbed VOCs. For VOC removal, advanced oxidation regeneration serves as an alternative to thermal oxidative regeneration [Notthakun *et al*, 1993; Cannon *et al*, 1994; Cannon *et al*, 1993; Glaze *et al*, 1986, 1987], which is energy intensive. Regeneration is a process during which the GAC is restored to a state as closely resembling the virgin carbon as possible. Advanced oxidation processes (AOP) are defined as processes which generate the highly reactive hydroxyl radical (OH^*) intermediate species from O_3 plus an initiator such as UV light, H_2O_2 , or metal oxides [Notthakun *et al*, 1993; Glaze *et al*, 1986, 1987]. Advanced

oxidants may, therefore, include O_3 plus associated highly reactive intermediates such as, OH^* , HO_2^* , etc.

Activated carbon serves as one of the unit processes in an air pollution system that also includes an air-phase photolytic chamber and an air/water stripping tower that has been designed to be regenerated by advanced oxidants. This system has been manufactured and commercially installed by Terr-Aqua Environmental Systems (TAES) of Fontana, CA. The systems have been installed to control the VOCs from 12 industries that together exhaust 0.5 million cubic feet per minute of air. During seven years of operation, these systems have not been cited for non-compliance with permitting regulations that have been set forth by the California South Coast District, one of the most stringent in America. Operation has proceeded while the GAC has been cyclically regenerated with AO at ambient temperatures and the process operators have not seen a need to replace the GAC in these beds.

At the Pennsylvania State University laboratory, advanced oxidant regeneration has been found to most effectively remove VOCs at the front face of a GAC bed [Cannon *et al*, 1996]. A critical parameter in the effectiveness of regeneration with advanced oxidants is their ability to penetrate into the GAC bed. Specifically, the advanced oxidants could affect loaded VOCs only if they successfully penetrate the GAC bed to the proximity of the loaded VOC. This penetration is limited by the extent to which the oxidants react with either the GAC or the organic compounds that have been adsorbed on to the GAC upstream of the point of interest.

The objectives of the current work have been to simulate several key aspects of full-scale GAC bed operations so that this operation can be enhanced. As a departure from direct simulation, the advanced oxidant intensities in these laboratory experiments were considerably higher than those experienced by the full-scale field GAC beds. Specific objectives of the work discussed herein have been to: (a) characterize VOC loading onto GAC beds through study of the mass transfer zone; (b) evaluate desorption/destruction of several representative VOCs, including MIBK, benzene, acetone, and 2,3-dimethyl-2-butene (DMB) from a loaded GAC bed; and (c) monitor the extent to which ozone and other advanced oxidants can penetrate through a fixed bed of GAC.

2.3 Literature Review

2.3.1 GRANULAR ACTIVATED CARBON

Granular Activated Carbon (GAC) adsorption offers a best available technology for capturing VOCs. Activated carbons contain extremely high internal surface areas and pore volumes that are well-suited for adsorbing VOCs. Generally, the measured surface area can range between 1000 and 1300 m²/g and the measured total pore volume can range between 0.7 to 1.8 cm³/g [Cannon *et al*, 1994; Hassler, 1974; Gregg and Sing, 1982].

Of prime importance to most commercial carbons is the unavoidable presence of oxygen on their surfaces. It has been suggested that the oxygen complexes formed on the

surface can include such groups as carboxyls, phenols, lactones, and quinone-type carbonyls [Barton and Harrison, 1975]. Reactions with advanced oxidants are hypothesized by the authors herein to cause more of these surface groups to form.

Adsorption can occur via physical (Van der Waals) adsorption or chemisorption. Physisorption is believed to proceed with a low activation energy and is therefore thermodynamically reversible [Gregg and Sing, 1982]. Chemisorption involves the sharing of electrons. Here, the force of attraction is much greater than in physisorption and may be thermodynamically irreversible [Gregg and Sing, 1982].

When adsorbates such as VOCs or other organic compounds load into a bed of GAC, they often create a mass transfer zone within the GAC bed. This zone is characterized by complete saturation of GAC adsorption capacity upstream of the mass transfer zone, and a virtual absence of any adsorbed organic compounds downstream of this zone [Snoeyink, 1990]. The active section of this zone is characterized by progressively decreasing adsorbate concentration as distance is traversed further downstream into the GAC bed. With continued loading of organic compounds, this mass transfer zone migrates downstream through the GAC bed.

It is conceivable that when ozone-UV processes become employed to reactivate a GAC bed, the oxidants could penetrate into the bed in a manner that is analogous to a loading mass transfer zone. The experiments herein are aimed at testing such a hypothesis.

2.3.2 OZONE REACTION WITH GAC

A number of studies, including the present work, have shown that GAC exhibits a high sorption capacity and/or reactivity with ozone and other advanced oxidants [Deitz and Bitner, 1972, 1973; Takeuchi and Itoh, 1993; Stephens *et al.*, 1986; Fendel *et al.*, 1995; Atyaksheva and Emel'yanova, 1989; Ellis and Tometz, 1972]. Several researchers have found that GAC is an extremely effective scavenger of ozone, and that the ozone which has sorbed onto GAC was not desorbed as ozone [Deitz and Bitner, 1972, 1973; Takeuchi and Itoh, 1993; Stephens *et al.*, 1986]. Moreover, the same researchers found that after ozonation of the GAC, high temperature exposure in an inert gas environment causes the generation of CO, CO₂, H₂O, and O₂. This suggests that ozone is chemisorbed on the GAC surface and reacts with it, rather than being physisorbed as O₃ on the GAC. Mechanisms for three reactions between O₃ and GAC have been proposed [Deitz and Bitner, 1972, 1973; Takeuchi and Itoh, 1993; Stephens *et al.*, 1986]. The first of these is the reaction of ozone with the C=C bonds within a solid carbon structure to form an epoxide. This process also causes the catalytic decomposition of ozone [Takeuchi and Itoh, 1993].

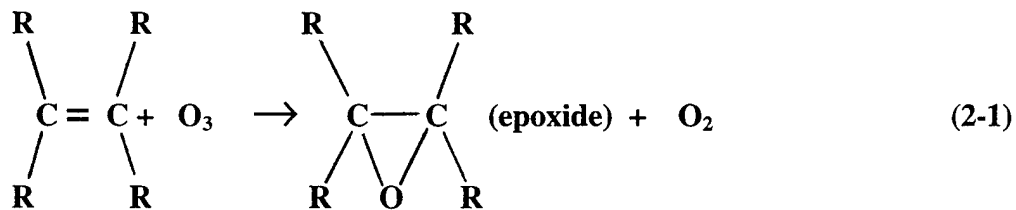

The overall reaction, then [Deitz and Bitner 1972, 1973; Takeuchi and Itoh, 1993] is:



A second reaction also involves the C=C bonds which are converted to ozonides [Deitz and Bitner, 1973; Stephens *et al*, 1986].

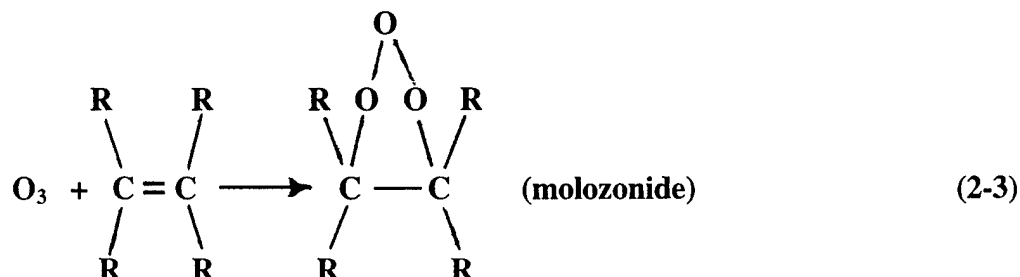

The ozonides in turn further react to partially oxidize the GAC to produce CO, CO₂, and surface functional groups [Deitz and Bitner 1972, 1973; Takeuchi and Itoh, 1993]. This overall process is summarized as:

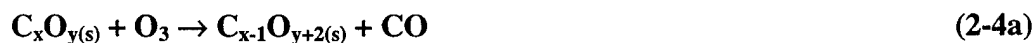

A third reaction also involves converting olefinic bonds to ozonides, but results in a more extensive oxidation of the GAC which generates two moles of gas (a CO plus a CO₂) for every mole of reactive ozone [Deitz and Bitner 1972, 1973; Takeuchi and Itoh, 1993].



The relative contributions of these processes and the number of sites available on the GAC for reaction with ozone would presumably control the ability of the ozone to penetrate into the GAC bed.

The majority of the previous studies published in the literature focus on elucidating the mechanism of the reaction between the carbon surface and ozone by studying the changes of the carbon surface during and after ozonation, or the products of

this interaction [Deitz and Bitner 1972, 1973; Takeuchi and Itoh, 1993; Stephens *et al*, 1986; Fendel *et al*, 1995; Atyaksheva and Emel'yanova, 1989; Ellis and Tometz, 1972]. To the knowledge of the authors' herein, only one study has determined the efficiency of a fixed bed of carbon for the removal of ozone [Ellis and Tometz, 1972]. That study [Ellis and Tometz, 1972] evaluated ozone capture by activated carbon and metal oxides with ozone concentrations and unit flow rates that were three orders of magnitude lower than for the experiments herein.

The goal of the research herein was to study how advanced oxidants interacted with a fixed GAC bed in order to characterize the ability of advanced oxidants to regenerate a fixed bed of GAC that had been used for removal of VOCs from an air-stream.

2.3.3 *ADVANCED OXIDANT REACTIONS WITH ORGANIC COMPOUNDS AND GAC*

Much of the literature regarding how advanced oxidants react with organic compounds pertains to ambient atmosphere conditions. These studies reveal that organic chemicals have a very wide range of lifetimes. Highly reactive species, such as ethene ($\text{CH}_2=\text{CH}_2$), acetaldehyde (CH_3CHO), and butanone ($\text{CH}_3\text{CH}_2\text{COCH}_3$), are quickly converted into secondary compounds when advanced oxidants are present [Atkinson, 1984; Finlayson-Pitts and Pitts, 1986; Singh and Zimmerman, 1992; Shah and Singh, 1988].

Other organic compounds have intermediate lifetimes on the order of hours to days in the atmosphere, where they react with naturally occurring advanced oxidants [Singh and Zimmerman, 1992; Altshuler, 1980; Cox *et al*, 1980, 1981; Huang *et al*, 1993]. These compounds may be degraded by a series of reactions initiated by gas-phase photo-oxidations. The gas-phase photo-oxidations generate ozone which may then react via two modes: (a) direct ozonation reactions and (b) free radical decomposition reactions with species such as OH^* , HO_2^* , O_2^* , and RO^* [Huang *et al*, 1993]. Reactions of advanced oxidants with VOCs could be expected to be analogous to reactions with the GAC structure as well.

The direct O_3 reaction is highly selective, and causes a relatively slow reaction. One potential pathway for the degradation of organic chemicals involves the reaction with high concentrations of ozone, particularly when the organic compounds include an isolated double bond [Singh and Zimmerman, 1992; Shah and Singh, 1988].

The OH^* radical, which can be formed during O_3 decomposition, reacts much more rapidly and far less selectively than does O_3 . This characterization holds true for the four VOCs that were selected for experimental evaluation here, namely MIBK, acetone, benzene, and 2,3-dimethyl-2-butene (DMB). The reactions between these four VOCs and OH^* proceed 5 to 10 orders of magnitude more rapidly than those with O_3 (Table 2-1). These four VOCs were selected because of their wide range of reactivities with advanced oxidants. Acetone and benzene are much less reactive, two orders of magnitude, than the primary compound of interest (MIBK), while DMB is more reactive by an order of magnitude. Similarly, a major mechanism for the degradation of saturated hydrocarbons

and other organic compounds proceeds via attack by hydroxyl radicals [Shah and Singh, 1988; Altshuler, 1980; Cox *et al*, 1980; Huang *et al*, 1993].

Table 2-1 Computed Second-Order Rate Constants for the Reaction of Organics with Advanced Oxidants

Compound	O ₃ <i>k</i> , cm ³ /molecule/s [Altshuler, 1980]	OH* <i>k</i> , cm ³ /molecule/s [Stephens <i>et al</i> , 1986]
Methyl isobutyl ketone	~≤10 ⁻²⁰ (a)	1.4 X 10 ⁻¹¹
Acetone	~≤10 ⁻²⁰ (a)	4.6 X 10 ⁻¹³
Benzene	7 X 10 ⁻²³	9.6 X 10 ⁻¹³
2,3-Dimethyl-2-butene	1.2 X 10 ⁻¹⁵	1.2 X 10 ⁻¹⁰

^a Range of computed values inferred from established values for similar saturated ketones [Atkinson and Carter, 1984]

For many organic compounds, reactions with other advanced oxidant radicals such as HO₂^{*}, O₂^{*} and RO^{*} may also be significant.

The main source of hydroxyl radicals in the UV reactor that has been used here is similar to that which occurs in a natural clean atmosphere where ozone is photolyzed. When light with a wavelength of less than 320 nm is absorbed by ozone, an electronically excited singlet oxygen [O(¹D)] may be produced. Others have found that approximately 90% of this excited singlet oxygen subsequently becomes collisionally quenched [Finlayson-Pitts and Pitts, 1986]. However, the remaining 10% reacts with water vapor in the air to form two OH radicals.



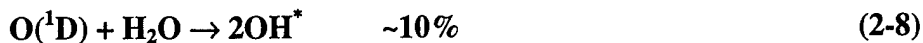

As indicated by the preceding reactions, the OH^* radical concentration is a function of:

(a) the ozone concentration, (b) the wavelength of the available light, and (c) the amount of water vapor present. In the above expression M represents any molecule which may collisionally stabilize the $\text{O}({}^1\text{D})$. M commonly is N_2 .

2.3.3.1 REACTIONS WITH ALKANES

Alkanes, including oxygenated forms such as MIBK and acetone, react exothermically with OH^* radicals by H atom abstraction from the C-H bond to form alkyl radicals [Atkinson, 1985]:



Similar reactions would be expected with alkane groups that appear within the GAC matrix. For alkanes with a chain length greater than three carbons, more than one form of the alkyl radical may be formed. In the case of oxygenated compounds, the favored radicals are those which are formed by the reaction with the carbonyl and adjacent carbon atoms.

Once formed, the alkyl radicals react rapidly with O_2 to form alkylperoxyradicals (RO_2^*).



The fate of the alkylperoxy radical depends on the ratio of NO concentration to HO_2^* radical concentration. If the NO concentration is greater than ~30 parts per trillion (ppt) the RO_2^* radicals will react with NO.



When NO concentrations are low relative to HO_2^* , as may occur in the experimental reactor herein, reactions involving the HO_2^* radical may also be important, causing the formation of carboxyl groups (ROOH).



The alkoxy radicals produced during the RO_2^*/NO may react with O_2 to form aldehydes and an HO_2^* radical. The HO_2^* radical produced may react with NO to form OH^* , thus completing the chain reaction. The larger alkoxy radicals ($\text{RO}^* \geq \text{C}_3\text{O}^*$) may also have other significant reaction pathways including unimolecular decomposition or isomerization. Methods are available for estimating the rates and relative yields of these different pathways, which may be on the order of 25% of the total product yield [Atkinson, 1985].

2.3.3.2 REACTIONS WITH ALKENES

The primary reaction of alkenes (such as DMB) is with OH^* radicals. However, since alkenes contain the double bonded carbon atoms, their reactivity with O_3 may also be important. For the main removal mechanism, the OH^* radical attacks the alkene via addition to the double bond and then follows a mechanism similar to alkanes as follows:



The β -hydroxyalkoxy radicals ($\text{HOCH}_2\text{CH}_2\text{O}^*$) that are formed can in turn react via three principle routes: (a) decomposition, (b) reaction with O_2 , or (c) isomerization. Atkinson found that decomposition is the dominant route.

Another significant atmospheric reaction involving alkenes is the reaction with O_3 which can be described, at least in part, by the two-step Crigee mechanism [Martinez *et al.*, 1981] as follows:

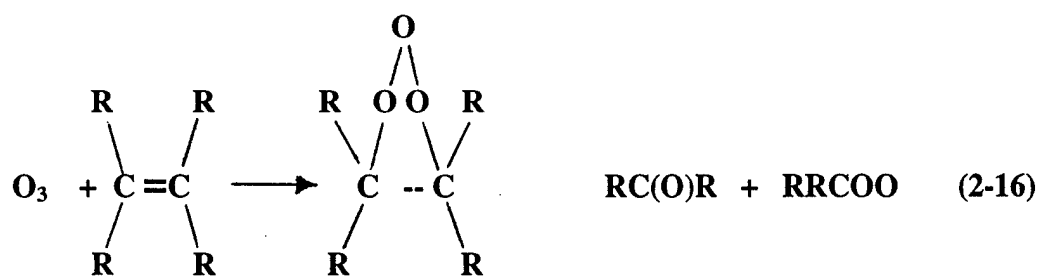

2.3.3.3 REACTIONS WITH AROMATIC COMPOUNDS

For aromatic compounds (such as benzene) the most significant pathway is the reaction with OH^* radicals [Atkinson, 1985]. The reaction mechanism may proceed via two pathways: (1) H atom elimination from the aromatic ring (which creates a phenol, in the case of benzene) or (2) OH^* radical addition to the aromatic ring itself, which cleaves the ring. Once ring cleavage has occurred, the resultant compound may be further degraded via mechanisms similar to that of alkenes. Similar reactions could be expected to occur with the extended aromatic ring structure that comprises GAC [Huang *et al.*, 1993; Atkinson and Carter, 1984].

2.4 Materials and Methods

2.4.1 LOADING AND REGENERATION EXPERIMENTS

Laboratory studies employed a GAC bed that was 1 1/2-inches in diameter and up to 6-inches high. This was placed in series with one of two UV configurations. The first comprised a 4-inch diameter by 5-foot long PVC pipe that contained three low pressure Atlantic Ultraviolet UV lamps (AU) (Hauppauge, NY). The second was a 4-inch diameter by 18-inch long PVC pipe that contained one low pressure Heraeus-Amersil NIQ 40/18 UV Lamp (HA) (Duluth, GA) (Figure 2-1). The ratio of lamp length to GAC bed volume for these laboratory experiments was several orders of magnitude greater than the ratio the manufacturer furnished as a common range for full-scale commercial systems. This higher ratio was employed in the laboratory in order to accelerate and enhance the advanced oxidant effects, so that they could be evaluated within laboratory time scales.

Four VOCs were adsorbed on the GAC bed, including methyl isobutyl ketone ($C_4H_9COCH_3$) (MIBK), acetone (CH_3COCH_3), benzene (C_6H_6), and 2,3-dimethyl-3-butene ($(CH_3)_2C=C(CH_3)_2$) (DMB). These represented a wide range of reactivities with advanced oxidants (Table 2-1). Among several hundred VOCs listed by Atkinson [1985], benzene and acetone represent two of the less reactive species with OH^* , and they were therefore selected for study. Also among this Atkinson [1985] list, DMB represents one of the most reactive with OH^* and it was therefore selected herein for evaluation. Several of these species also pose significance within coating industries.

VOC loading was achieved by passing a VOC-laden air stream through the GAC bed at a flow rate of 8 L/min. This flow rate resulted in a 1.3 second empty bed retention time and a 0.12 m/sec face velocity. This retention time conformed to a common range of full-scale air-phase GAC adsorption systems, as stated by the manufacturer. VOC concentration within the air stream was attained by bubbling air through liquid VOC. The concentration was varied by means of a split flow apparatus, with an adjustable amount of the air stream being diverted through the liquid VOC. The flow through the liquid VOC was controlled with rotometers.

The loaded bed was regenerated for up to 96 hours using ozone and the oxidants that were created by the UV light. Influent flow rate to the GAC bed during regeneration was 1 L/min for the AU reactor and 1.5 L/min for the HA reactor. These conditions created an influent ozone concentration of 250 to 350 ppm. This variation was due to the decay of the UV lamps. They initially produced 350 ppm and were replaced when the O₃ concentration fell to 250 ppm. This drop occurred over the course of 718 hours of operation. The efficiency of the oxidation and/or desorption of the VOCs that had been adsorbed was then determined. The air supply for all the loading and regeneration experiments was dried using an in-line Dryrite cartridge and cleaned via an activated carbon filter and a 13X molecular sieve. For some experiments, the air was re-humidified by bubbling it through deionized water.

2.4.2 ADSORPTION ANALYSIS.

VOC adsorption tests were conducted by placing approximately 2 milliliters (mL) of the liquid VOC of interest into airtight bottles. The bottles were left capped overnight to ensure that the air inside was saturated with the vapors of the liquid VOC. The bottles were then laid on their sides and aluminum foil "boats" were placed inside the bottles, which contained approximately 1 to 1.5 grams of GAC which had been dried at 105°C for 24 hours. These GAC samples were allowed to adsorb vapors from the bottle's gas phase for one hour each. At the end of this time, the carbon was taken out, weighed and immediately transferred to an extraction vial. The extent of adsorption that was achieved in an hour represented roughly 80-90% of the capacity that was achieved in 24 hours [Singh, 1995]. The one-hour capacity represented the more easily-accessible capacity, which represented the nature of capacity that the authors sought to characterize.

Carbon Disulfide (CS₂) extraction was carried out and the liquid extract was analyzed on a Varian 3400 Gas Chromatograph (Walnut Creek, CA) that was equipped with a Supelcowax 10 megabore capillary column (Supelco Inc, PA). One-hour adsorption was also computed on the basis of mass balances. These tests showed that CS₂ extracted between 89 to 96 % of the adsorbed MIBK. There was high repeatability in the data obtained from the above procedure, with typically $\pm 5\%$ variation between one replicate and another.

Pore volumes were characterized with argon as the adsorbate (Accelerated Surface Area and Porosimetry System ASAP 2000 by Micromeritics, Norcross, GA). The

adsorption isotherms were interpreted by the Density Functional Theory (DFT) software that was provided by Micromeritics [Olivier and Conklin, 1994].

2.4.3 VOC ANALYSIS

The extent to which VOCs were loaded onto the GAC, when the GAC was used to treat a contaminated air stream, was determined both by a mass balance and by carbon disulfide (CS₂) extraction of the loaded GAC. CS₂ extraction was accomplished by weighing out 0.29±0.04 g of loaded GAC into a 4 mL vial, to which we added 1000 µL of CS₂ per 0.1 g of loaded GAC. The solution of CS₂ and GAC was allowed to stand overnight. The extract was analyzed using a Hewlett-Packard 5890 Series II Gas Chromatograph (Valley Forge, PA) that was equipped with a flame ionization detector. Previous comparisons between the mass balance and extraction methods had shown that the CS₂ method consistently extracted 90-95% of MIBK loaded onto GAC [Singh, 1995; Singh and Cannon, 1995]. The regeneration efficiency and by-product formation was analyzed using CS₂ extraction, gas chromatography, and gas chromatography/mass spectrophotometry (GC/MS).

2.4.4 OZONE AND TOTAL OXIDANT PENETRATION EXPERIMENTS

A low pressure HA lamp was employed in the second apparatus described above in order to test the extent to which ozone and oxidation potential could penetrate into a GAC bed. The penetration was measured as a function of both time (from 0 to 96 hours) and depth (from 1/8-inch to 3-inches). The penetration at each depth studied was

obtained by filling the GAC bed to the specified depth namely, 1/8", 1/4", 1/2", 1", or 3".

An air stream flowing at 1.5 L/min laden with advanced oxidant was then passed through the desired bed and the ozone and/or total oxidant was measured at the bed effluent.

Ozone concentration was measured by flowing the bed effluent through a teflon tube to a Dasibi 1008-HC Ozone Meter (Glendale CA). This meter used a spectrophotometric cell with a wavelength of 253.7 nm to determine the absorbency of the air sample. The O₃ concentration of the influent air stream followed the same pattern as the regeneration experiments.

Total advanced oxidant was measured using the 2350 E Ozone Demand/Requirement Semi-Batch Method [American Public Health Association, 1992]. In this method, the air stream containing advanced oxidants is bubbled through a KI solution for a standardized amount of time, often 10 minutes. The advanced oxidants convert I⁻ to IO₃⁻. As determined by this method, Total Advanced Oxidants included O₃, OH^{*}, HO₂^{*}, H₂O₂, organic peroxy radicals, and a host of other oxidants, but did not include O₂, NO, NO₂, CO, CO₂, or carboxylated organic compounds.

For oxidant penetration into loaded GAC bed experiments, the GAC bed was loaded with the VOC by suspending a GAC sample in a sealed bottle that was saturated with the VOC for 24 hours. A small pool of the VOC was placed in the bottom of the bottle to ensure that the air phase remained saturated with the VOC during the loading process. After loading with VOC, the GAC was transferred from the bottle to the regeneration apparatus, and the GAC bed was regenerated with AO for 24 hours using

humid air passed through the bench-scale reactor that contained a 18-inch long HA UV lamp.

Elemental analysis of virgin and regenerated GAC was conducted via proximate analysis by the Earth and Mineral Sciences Department at the Penn State University.

2.5 Results and Discussion

2.5.1 *LOADING AND REGENERATION RESULTS*

MIBK loading was conducted at concentrations of roughly 35 parts per million (ppm), 160 ppm, 325 ppm, and 12,000 ppm, by volume. Throughout this paper “ppm” refers to parts per million by volume. Concentrations of 35 to 160 ppm represented the range commonly encountered in industrial applications that employ the Terr-Aqua system, according to the manufacturer of that system. In comparison, 12,000 ppm provided insight into how the GAC performs at high concentrations and can be used to evaluate a loading isotherm for the GAC/MIBK system. The data points shown in Figures 2-2 and 2-3 represent the averages of replicated measurements. Typically, variance ranged by 9 (mg/g GAC)^2 , and rarely exceeded 25 (mg/g GAC)^2 . The standard deviations are shown in each of these Figures (Figures 2-2 to 2-5). The values shown at one condition on a given line are representative of the standard deviations for the full duration of a test under those experimental conditions.

At the end of the 72 hours of exposure to 35 ppm of MIBK, no detectable amount of MIBK had escaped the 6-inch GAC bed. This is shown in Figure 2-2, where the y-axis

is the mass of MIBK in mg which is adsorbed by the GAC as determined by CS_2 extraction. The data has been normalized to a per gram of GAC basis. The x-axis is the distance from the influent end of the GAC bed (in inches). As indicated, the mass transfer zone (MTZ) spanned 1 to 3 inches, representing the area within the GAC bed where active adsorption occurred [Snoeyink, 1990]. The MTZ migrated from the first inch of GAC bed during a 24 hour run to the first two inches of the bed during a 72 hour run. MIBK loading reached a saturation concentration of 250 mg/g GAC.

At a loading rate of 325 ppm, the MIBK did not escape the 6-inch bed until the full duration of a 24 hour run (Figure 2-3). The mass transfer zone (MTZ) was approximately 5 inches which was shown particularly well in the 12 hour run curve. The mass transfer zone progressed through the GAC bed as shown by the MTZ location for the successive run times (2 hrs, 4 hrs, 12 hrs, and 24 hrs). A saturation concentration of 270 mg MIBK/g GAC could be achieved under this loading rate and temperature.

When MIBK was loaded at 12,000 ppm, break-through occurred after only 1 hour of loading, and the bed was completely saturated with MIBK in approximately 2 hours (Figure 2-4). The mass transfer zone in this instance covered 3 to 5 inches of the bed. However, the saturation loading was still about 300 mg/g GAC, only slightly higher than the 250 mg/g GAC that was observed for a far lower influent MIBK concentration, indicating that the maximum loading of MIBK is weakly dependent on influent concentration [Cannon *et al* 1996, Dusenbury and Cannon 1996].

Following these adsorption runs, the extent to which the loaded GAC beds could be regenerated with the advanced oxidants was investigated. The first series of

experiments tested a GAC bed that had been completely saturated with MIBK at 12,000 ppm. This bed was regenerated for 24 hours using the AU lamp set-up. This regeneration achieved 83% removal of MIBK at the inlet surface (i.e. 17% of the MIBK remained, as determined by CS₂ extraction of the GAC), where initial contact occurred between the ozone/OH* radicals and the GAC (Figure 2-5). This effect dropped to 33% MIBK removal at 1 inch, and to 25% at 2 inches. Roughly 20% was removed at distances greater than 2 inches. Thus, in these laboratory experiments, the regenerated area may be considered the VOC adsorption capacity that was regained during a subsequent loading of the GAC if the GAC itself had not been altered by the regeneration process.

The UV/O₃ removal efficiency was compared with the desorption which occurred under similar conditions in control runs that used no advanced oxidants. In the control runs, a loaded GAC bed was treated with clean humidified air that was heated to the same temperature (38°C) as the regeneration air. The removal under these conditions reached 30% at the influent end of the GAC bed, then dropped to 20% within the balance of the GAC bed (Figure 2-5). The removal of MIBK, therefore, was enhanced by the presence of advanced oxidants through the first inch or two of the GAC bed. This suggested that surface reactions were occurring between the oxidants, VOCs, and GAC.

In another round of loading and regeneration experiments, a virgin, coconut-based GAC was exposed to an air stream that was laden with 160 ppm MIBK. After 24 hours of this loading regime, the adsorbed MIBK concentrations reached levels as shown in Figure 2-6. This loading was characterized by saturated values of 230 mg/g GAC in the

first two inches of the GAC bed and a mass transfer zone that tailed off to low loading values at 4 to 5 inches of bed depth. The 160 ppm condition represented a typical upper bound of common industrial exhaust air conditions for the Terr-Aqua Systems, per the manufacturer.

After this partial loading at 160 ppm, the GAC bed was regenerated with AO for 24 hours by employing humid air which had passed through the bench-scale reactor that contained a HA UV lamp. In this instance, MIBK loading at the face of the GAC reactor was reduced from 225 to 100 mg/g GAC representing 60% removal (Figure 2-6), but removal was only 20% at 1 inch into the bed, and regeneration increased the loading of MIBK at depths greater than 1 inch. This indicated that some of the MIBK was desorbed from the front of the bed and then carried further into the bed where it re-adsorbed. The data points for the replicates of these experiments are shown in Figure 2-6.

In effect, regeneration moved mass from the front of the GAC column, due to the presence of advanced oxidants, to a zone deeper in the bed. The area deeper in the bed remained favorable since the advanced oxidants were not able to penetrate significantly beyond the first inch or two of GAC. Little or no MIBK escaped from the GAC bed as demonstrated by the use of a second (or guard) GAC bed to trap VOCs in the off-gas.

CS₂ extractions of both the UV/O₃ treated GAC bed and the off-gas bed were analyzed using GC and GC/MS. The results suggest that roughly 10% of the MIBK was degraded by the advanced oxidation process. Analysis of the end products from the reactions (Figure 2-7) indicate that a number of different organic fragments were formed during the process. The smallest molecules which have been identified include acetone

and acetic acid. Note that flame ionization does not detect CO or CO₂. Other products of the MIBK (CH₃CHOCH₂CH(CH₃)₂) degradation that have been identified by GC/MS include 3-methyl-butanoic acid (CH₃CH₂CH(CH₃)COOH), 2-methyl-propanoic acid ((CH₃)₂CHCOOH), valeric acid (CH₃(CH₂)₂COOH), 4-methyl-3-penten-2-one (CH₃COCHC(CH₃)₂) and 2,4-dimethyl-3-pentanol ((CH₃)₂CHCHOHCH(CH₃)₂). These products show that the MIBK was being broken down into molecules smaller than the parent compound, and that it was becoming more oxygenated. The additional smaller peaks in Figure 2-7 suggest that several more products were generated which have not yet been identified.

The range and variety of products found after the AO regeneration may be due to the MIBK splitting at different carbons within the pentane chain. Atkinson reported that a hydrogen atom abstraction by OH* was most likely to occur at the C=O site (creating a carboxyl group), or adjacent C atoms for oxygenated compounds. The first of these reactions was observed in this work.

2.5.2 OZONE AND TOTAL OXIDANT PENETRATION RESULTS

In light of the results from the above experiments, it became quite apparent that the ability of advanced oxidants to penetrate into the GAC bed represented the key to the success of the regeneration process. Naturally, unless the oxidants could penetrate the GAC bed to the location of the adsorbed VOCs, the VOCs could not be removed or degraded by physical-chemical means. As discussed in the literature review, [Deitz and Bitner, 1972, 1973; Takeuchi and Itoh, 1993; Stephens *et al*, 1986] GAC has been found

to be an extremely effective scavenger of ozone, and this was confirmed in the present work. However, the impact of this GAC scavenging on the overall performance of advanced oxidants for displacing and/or destroying VOCs had not previously been explored and that has been the focus of the research herein. The authors, therefore, sought to test the extent to which ozone and advanced oxidants could penetrate a GAC bed when the bed was simultaneously being exposed to water humidity, or when the bed had been previously loaded with an array of VOCs that had varying levels of reactivity with ozone and advanced oxidants. These tests also evaluated how this penetration was influenced by time and by the depth of the GAC bed.

The results of these ozone and total oxidant penetration experiments are shown in Figures 2-8 to 2-15. All of these tests were conducted in replicate, and the data points shown in these figures represent the averages of these replicates. Typically, variance was 4 (percent)², and did not exceed 25 (percent)². The standard deviation is shown in each of these Figures (Figures 2-8 to 2-15). The values shown at the 24 hour times are representative of the standard deviations for the full duration of a test under those experimental conditions.

2.5.2.1 INFLUENCE OF HUMIDITY, TIME, AND BED DEPTH

Water humidity facilitated more ozone to penetrate into a GAC bed than was achieved when the air was dry, as shown in Figure 2-8. Specifically, in a 30 minute run, 85% of the ozone was removed from a humid air stream that contained 350 ppm of ozone when flowed through a 1/8-inch thick virgin GAC bed at a rate of 1.5 L/min. By the time

the ozone-laden air stream had penetrated through 2-inches of GAC bed, the initial ozone concentration had been reduced by 95%. Virtually none of the ozone penetrated 4-inches into the GAC bed during the first 30 minutes. When the ozone-laden air stream was dry, even less ozone escaped from the GAC bed.

Intriguingly, advanced oxidant penetration into the GAC bed was found to be a function of time. The total oxidant concentration and ozone concentration that penetrated a given GAC depth increased with length of exposure to the oxidant-laden, humid air flow. This was particularly noticeable when an 1/8-inch thick GAC bed was exposed to an oxidant-laden, humid air flow for 96 hours. The air flow was 1.5 L/min. Initially only 4% of approximately 325 ppm of ozone and 4% of 15000 ppm of advanced oxidant (as O₃) remained in the air stream after passing through the GAC bed (Figures 2-9 and 2-10). In an 1/8-inch bed, this effluent concentration rose to 13% of the ozone and 8% of the advanced oxidant following 1/2 hour run time. The rate of increase in oxidant penetration then leveled off and rose at a slow but consistent rate, reaching 26% for ozone and 14% for oxidation potential after 24 hours of run time. The extent of penetration decreased with increasing bed depth: with a 1/2-inch bed depth, this amounted to only 9% ozone and 1% total oxidant penetration following 24 hours exposure (Figures 2-9 and 2-10).

This trend toward increasing penetration continued throughout the duration of a 96 hour run when an 1/8-inch thick GAC bed was exposed to oxidant-laden, humid air (Figure 2-11). Following 96 hours of run time, ozone penetration reached 83% and total

oxidant reached 78% penetration and the curves showed no sign of leveling off (Figure 2-11).

A mass balance was conducted on a 1-inch thick bed of virgin GAC that was exposed to 275 ppm ozone in a humid air stream at a rate of 1.5 L/min for 24 hours. Results revealed that the mass of this 1-inch thick bed (29 mL) of virgin GAC decreased by 1% after 24 hours of exposure to advanced oxidants. The overall change in GAC mass is the result of two opposing mechanisms. The first is an increase in surface functional groups containing oxygen, that would actually increase the overall mass. The second is the release of gasified CO or CO₂ groups that would cause a decrease in mass. Elemental analysis of the GAC shows that the oxygen content of the GAC sample increased from 6 to 11%. This should have caused a 7% increase in the overall mass of the GAC. For the overall mass of the GAC to decrease by 1% while the oxygen content increased by 7%, then 11% of the original carbon mass must have been gasified during 24 hours of exposure to oxidants.

Similarly, following 96 hours of AO exposure, the GAC mass decreased 9% and proximate analysis revealed that the GAC contained 11% oxygen. Thus, 15% of the virgin GAC's carbon may have been gasified following 96 hours advanced oxidation of exposure. A mass balance of these oxidation rates, as compared to the flow of ozone and other advanced oxidants, suggests that if all the mass of ozone that contacted this bed reacted with the GAC, the ozone could have achieved at a maximum only a fifth to a third of this oxidation. The balance must have come from the other advanced oxidants that appeared in the influent air stream.

The rapid initial increase of oxidation penetration into the GAC bed and the subsequent gradual increase in penetration indicates that the GAC surfaces may have contained a limited number of exposed sites for the oxidation of the GAC and the formation of surface functional groups [Cannon *et al*, 1996; Deitz and Bitner, 1972, 1973]. As these exposed sites were consumed, the concentration of ozone that penetrated through the bed increased rapidly because a lower fraction of the ozone was reacting with the carbon surface. Following this initial stage, the remaining consumption of ozone could be due to (a) the reduction of ozone to oxygen that is catalyzed by the carbon surface, (b), surface etching and gasification of the GAC, which exposes new available carbon sites, and/or (c) ozone diffusion to less accessible sites that can be reached only by diffusion through micropores [Cannon *et al*, 1996; Deitz and Bitner, 1972, 1973; Takeuchi and Itoh, 1993].

2.5.2.2 ADVANCED OXIDANT PENETRATION INTO VOC-LADEN GAC

The effect on advanced oxidant penetration due to loading a GAC bed with a VOC could depend both on (a) the reactivity of the particular VOC with ozone, OH^* radicals, and other AOs, and on (b) the strength or reversibility of adsorption of the VOC on GAC. Four VOCs representing the widest reactivity range possible, based on published data, were chosen to evaluate the effect of VOC reactivity on (a) AO regeneration efficiency of VOC laden GAC and (b) AO penetration into a GAC bed. The four VOCs in order of lowest-to-highest reactivity with OH^* were acetone (a common solvent), benzene (a common component of petroleum products), methyl isobutyl ketone

(a common industrial solvent and paint ingredient), and 2,3-dimethyl-2-butene (chosen for its high reactivity with oxidants). The rate constants of these VOCs with ozone and OH^* radicals have been listed in Table 2-1.

Experiments revealed that O_3 and AO penetrated the VOC-laden GAC beds as shown in Figures 2-12 to 2-15. These data suggest that for the first two hours that the laden bed was exposed to the oxidants, the extent of O_3 and advanced oxidant penetration was a function of the nature of the VOC that had been loaded. At the onset of these tests, benzene, one of the least reactive compounds chosen, allowed 68% of the ozone and 20% of the oxidation potential (Figures 2-12 and 2-13) to penetrate through the 1/8-inch bed. In contrast, the most reactive compound, DMB, allowed none of the ozone to penetrate (Figure 2-14) and only 8% of the oxidation potential to penetrate (Figure 2-15). The remaining two compounds, acetone and MIBK, allowed oxidant penetration within the range defined by benzene and DMB. Acetone allowed 20% of the ozone and 5% of the advanced oxidant to penetrate the bed, while MIBK allowed 18% of the ozone and 10% of the advanced oxidant to penetrate the bed.

After 24 hours of AO exposure, >95% of the acetone, 65% of the DMB, and 75% of the benzene were removed from this 1/8-inch thick layer of GAC as shown in Table 2-2. By this time, the penetration of advanced oxidant into the GAC bed behaved similarly to that of virgin GAC (Figures 2-12 to 2-15).

Table 2-2 Adsorption Capacity/ Regeneration Efficiency in First 1/8-inch of a GAC Bed of VOCs Studied

Compound	VOC Concentration in Air-Phase During Loading Phase (Calculated, ppm)	Adsorption Capacity (mg/ g GAC)	Regeneration/ Removal After 24 Hours
Methyl isobutyl ketone	6,700	292	60 %
Acetone	230,000	262	>95 %
Benzene	99,000	270	75 %
2,3-Dimethyl-2-butene	250,000	200	65 %

In the case of MIBK, the AO penetration behaved quite differently than for the other three VOCs. For MIBK, AO penetration continuously increased with time, up to 62% for ozone (Figure 2-12), and 56% for total oxidant following 24 hours of AO exposure (Figure 2-13). Thus, the presence of the MIBK and its partial oxidation products appeared to profoundly influence the AO penetration even after 24 hours. This compound and products may have effectively protected the GAC surface from further reaction with the advanced oxidants.

2.6 Summary and Conclusions

In summary, the effectiveness of VOC loading and advanced oxidant reactivation of GAC was evaluated. Laboratory-scale tests monitored the mass transfer zone that was created when Methyl isobutyl ketone (MIBK) was loaded into a GAC bed under ambient

temperature and pressure, with an empty bed contact time of 1.3 seconds. Results revealed that the loading of MIBK was characterized by a well-defined mass transfer zone which spanned approximately 3 to 5 inches with a maximum capacity of approximately 300 mg/ g GAC. Several other VOCs were investigated including acetone, benzene, and 2,3-dimethyl-2-butene. These compounds all had maximum capacities in the range of 200 to 300 mg/ g GAC.

For MIBK, advanced oxidant desorption/destruction was the most pronounced within the first inch of the GAC bed. Advanced oxidant regeneration achieved a maximum desorption/destruction efficiency of 85% at the influent face of the GAC bed and dropped rapidly to 20% at 3-inches. The remaining 3 inches of the bed continued to achieve 20% regeneration in a 24 hour run. Roughly 10% of the MIBK was converted to products that contained fewer carbon atoms and more oxygen functional groups. The additional VOCs which were studied during the loading phase of the study were also subjected to the advanced oxidant regeneration. These compounds experienced destruction/ desorption efficiencies of 65 to 95 % in the first 1/8-inch depth of the bed.

Intriguingly, this study has also demonstrated that when VOCs were removed from GAC surfaces in the presence of advanced oxidants, more VOC mass was removed at a given temperature than when the same VOCs were removed by mild heating to the same temperatures in a humid air environment that contained no advanced oxidants. This suggests that the advanced oxidants were creating a zone within the GAC bed in which adsorption was significantly less favorable, which allowed increased desorption and enhanced destruction of the VOCs.

GAC very effectively captured ozone and associated advanced oxidants from an air stream during initial time periods, but penetration of ozone and advanced oxidants increased with time. A bed of GAC 1/8-inch deep was able to remove over 95% of the initial advanced oxidant concentration from an air stream which was passed through the bed in a 30 minute experimental run. After 24 hour run time, 14% of the initial oxidant concentration was able to penetrate through 1/8-inch of GAC. The removal of advanced oxidants from air by GAC was accompanied by a decrease in mass which may have been attributed to the oxidation of the GAC surface. The ozone and other advanced oxidants caused an increase in the oxygen content within the GAC, presumably attributed to oxygen functional groups that were created on the GAC surfaces. The ozone and advanced oxidants further caused gasification of the GAC at ambient temperatures.

The ability of ozone and advanced oxidants to penetrate a GAC bed was influenced somewhat by the presence of VOCs within the bed. Most significantly, when GAC was loaded with MIBK, the bed allowed greater AO penetration for prolonged times. For the other three VOCs, AO penetration after 6 - 24 hours was generally the same as when the GAC bed had not been loaded with VOCs.

Acknowledgments: We thank the Pennsylvania State University and the Applied Research Laboratory (ARL) for their technical assistance and program management; and the Marine Corps Logistics Bases and the Environmental Protection Agency (EPA) for their input and project review. Specific thanks are extended to Lewis Watt of ARL, John House and Ron Vargo of the Marine Corps, and Chuck Darwin of the EPA.

This study was funded by the Strategic Environmental Research and Development Program (SERDP), and by the Office of Naval Research via an Augmentation Award For Science and Engineering Research Training (AASERT).

FIGURE 2-1: GAC BED UV/OZONE REGENERATION SYSTEM

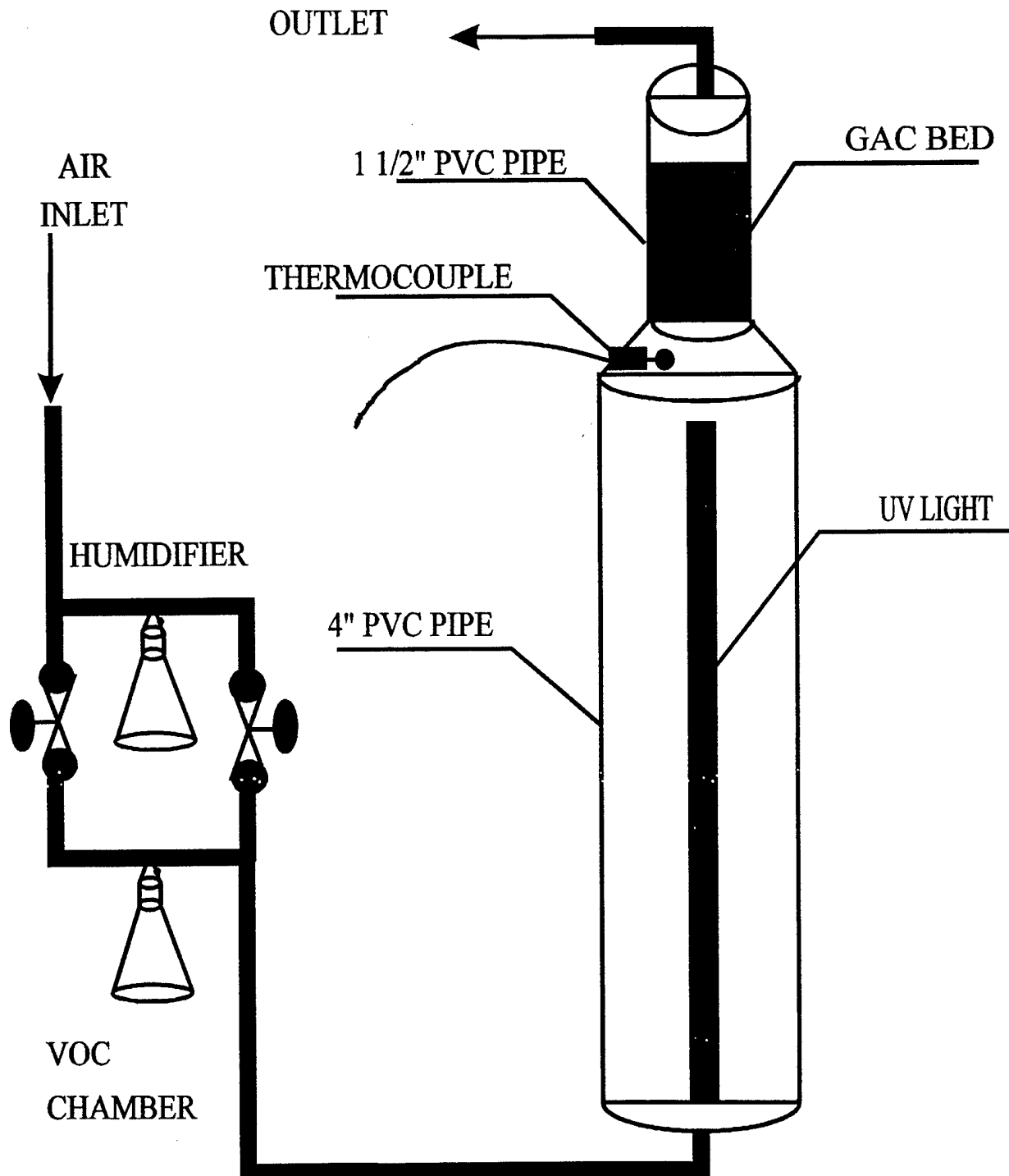

**FIGURE 2-2: MIBK MASS TRANSFER ZONE IN GAC BED
AT 35 PPMV**

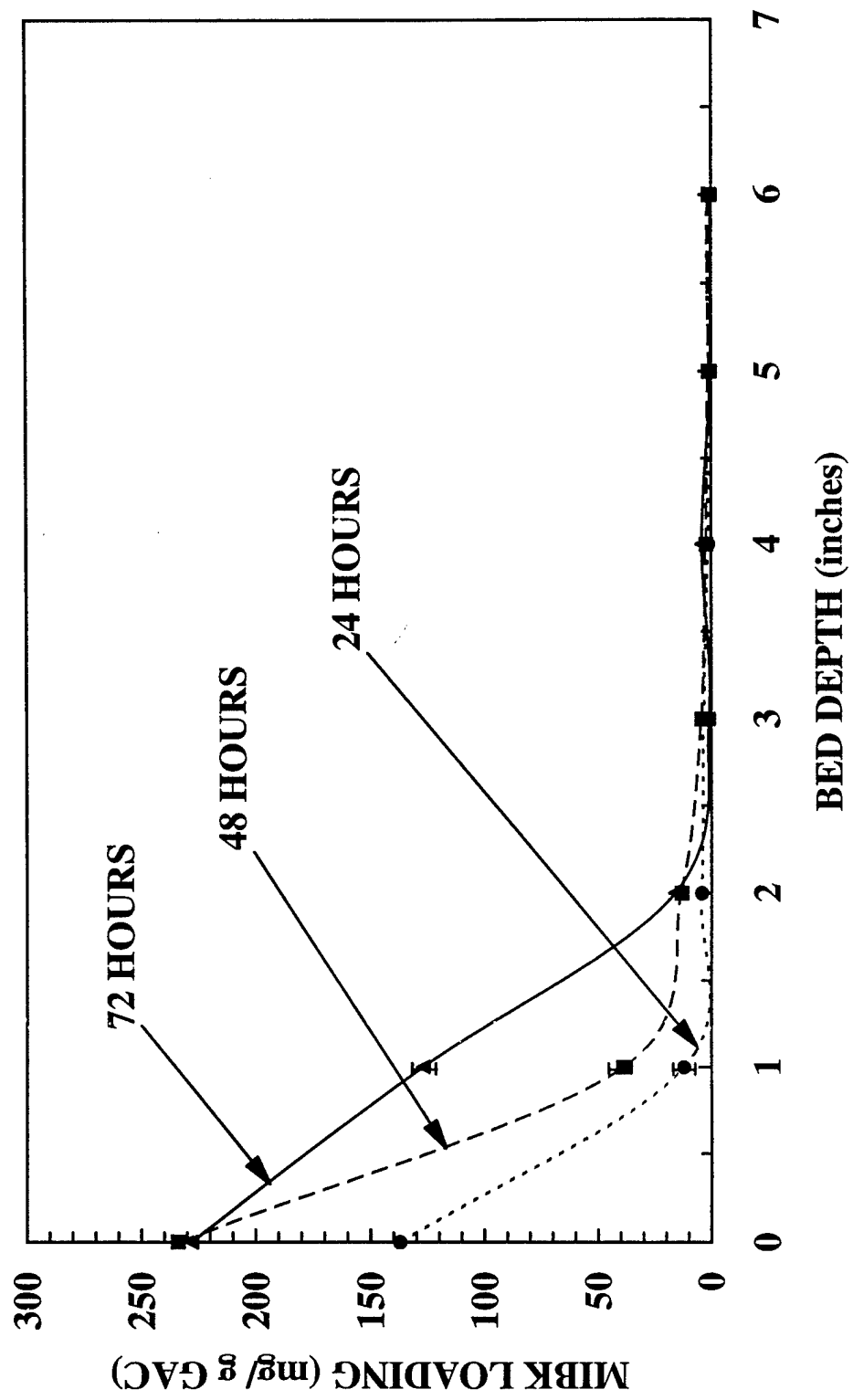

**FIGURE 2-3: MIBK MASS TRANSFER ZONE IN GAC BED
AT 325 PPM**

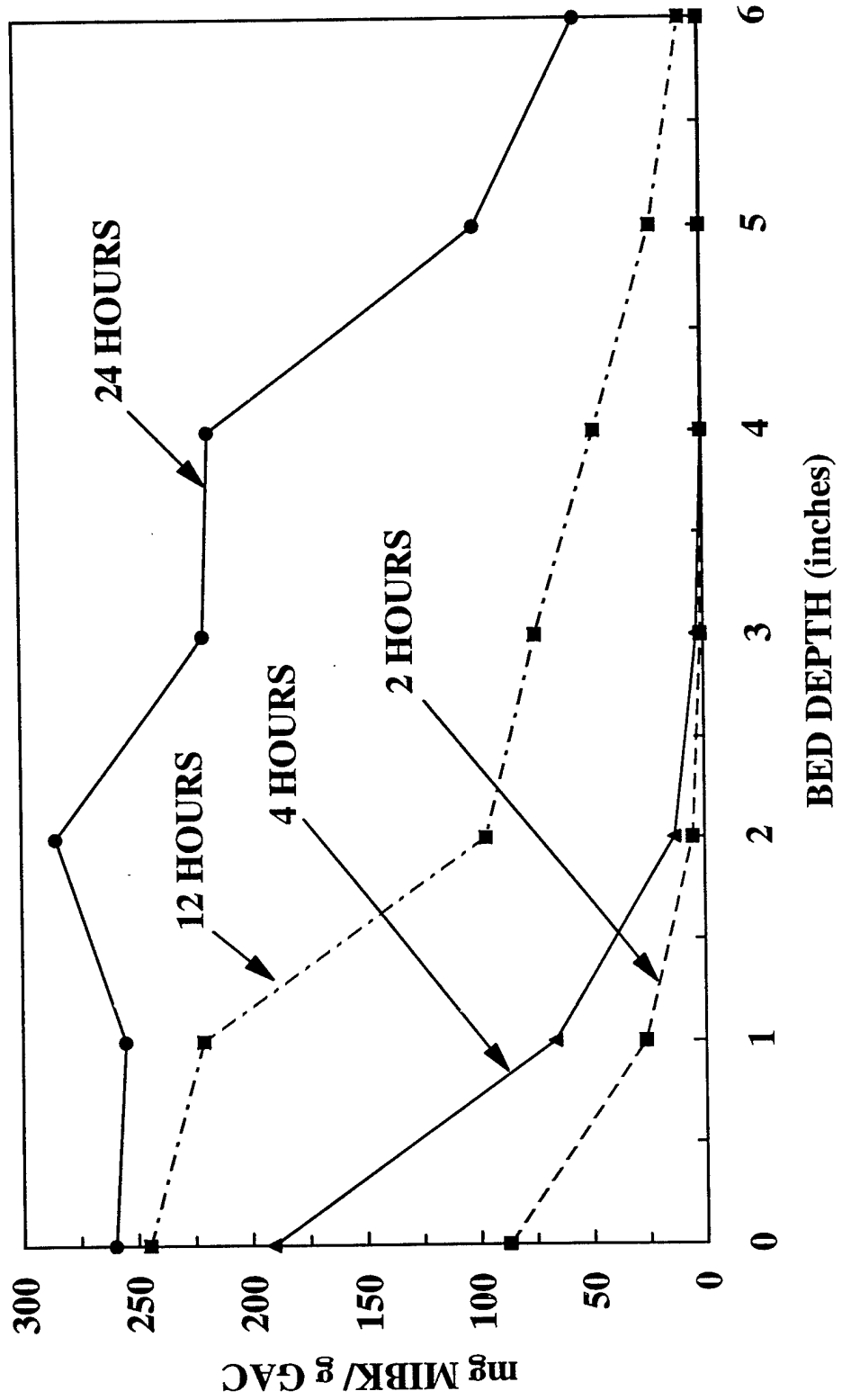

**FIGURE 2-4: MIBK MASS TRANSFER ZONE IN GAC BED
AT 12,000 PPMV**

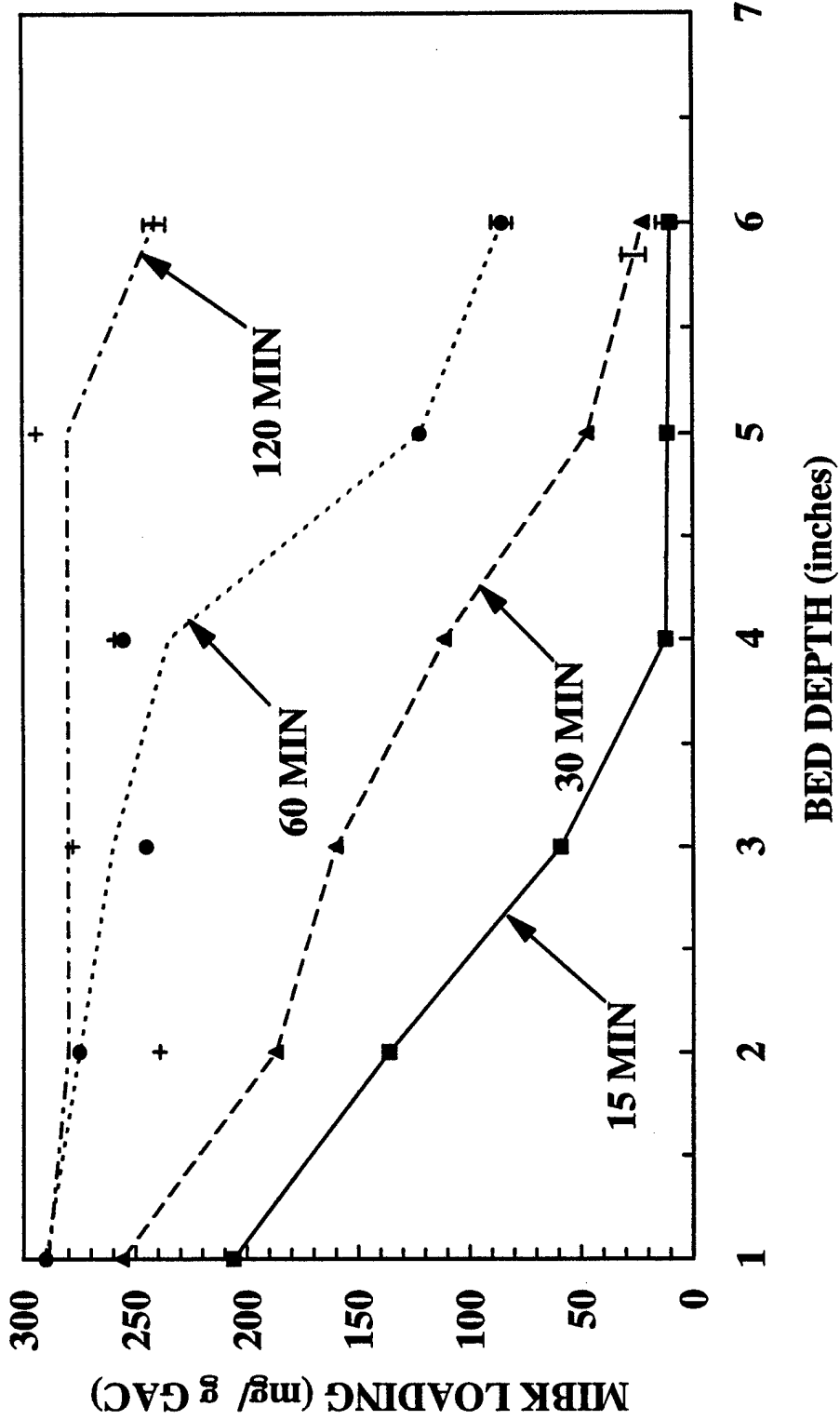
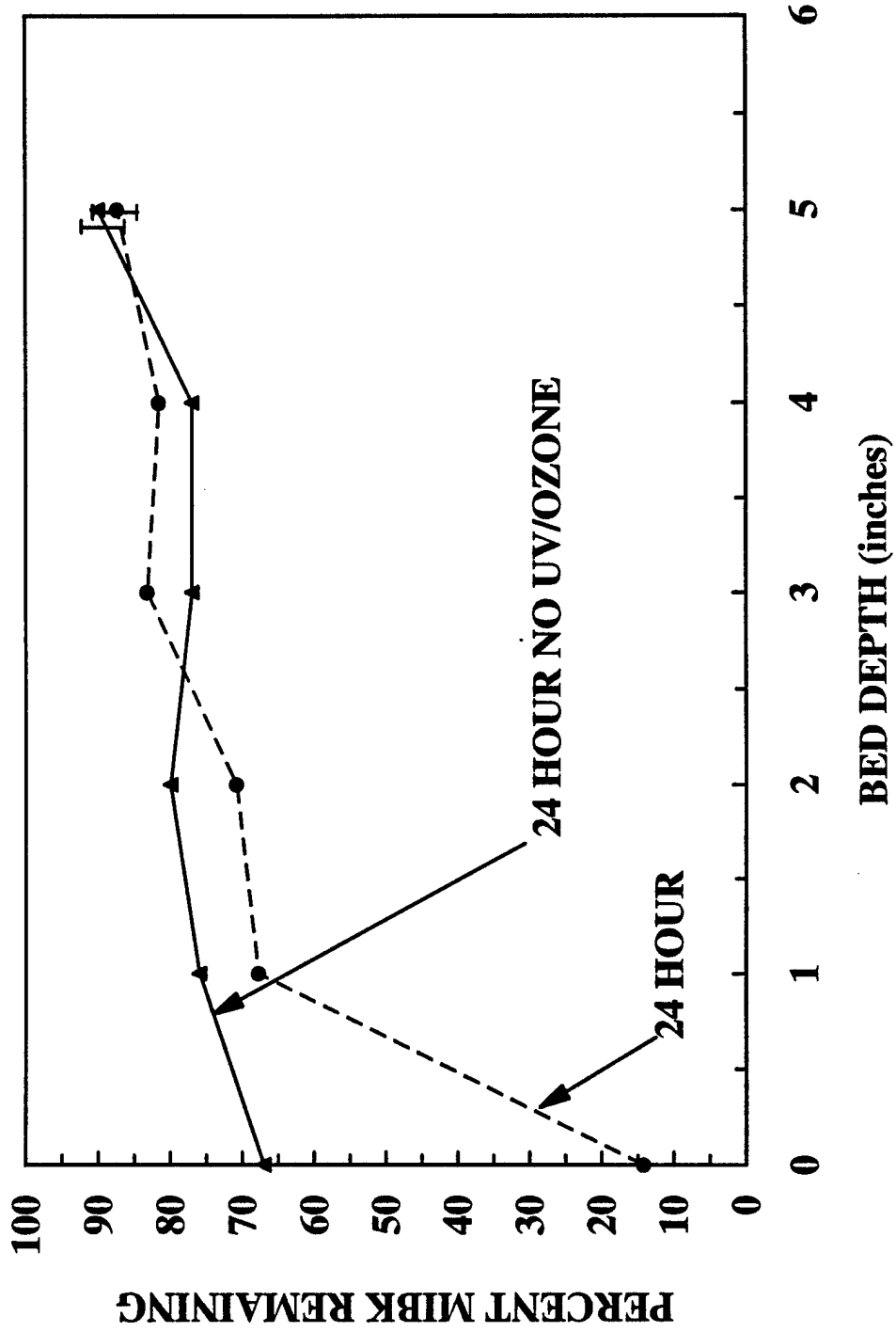
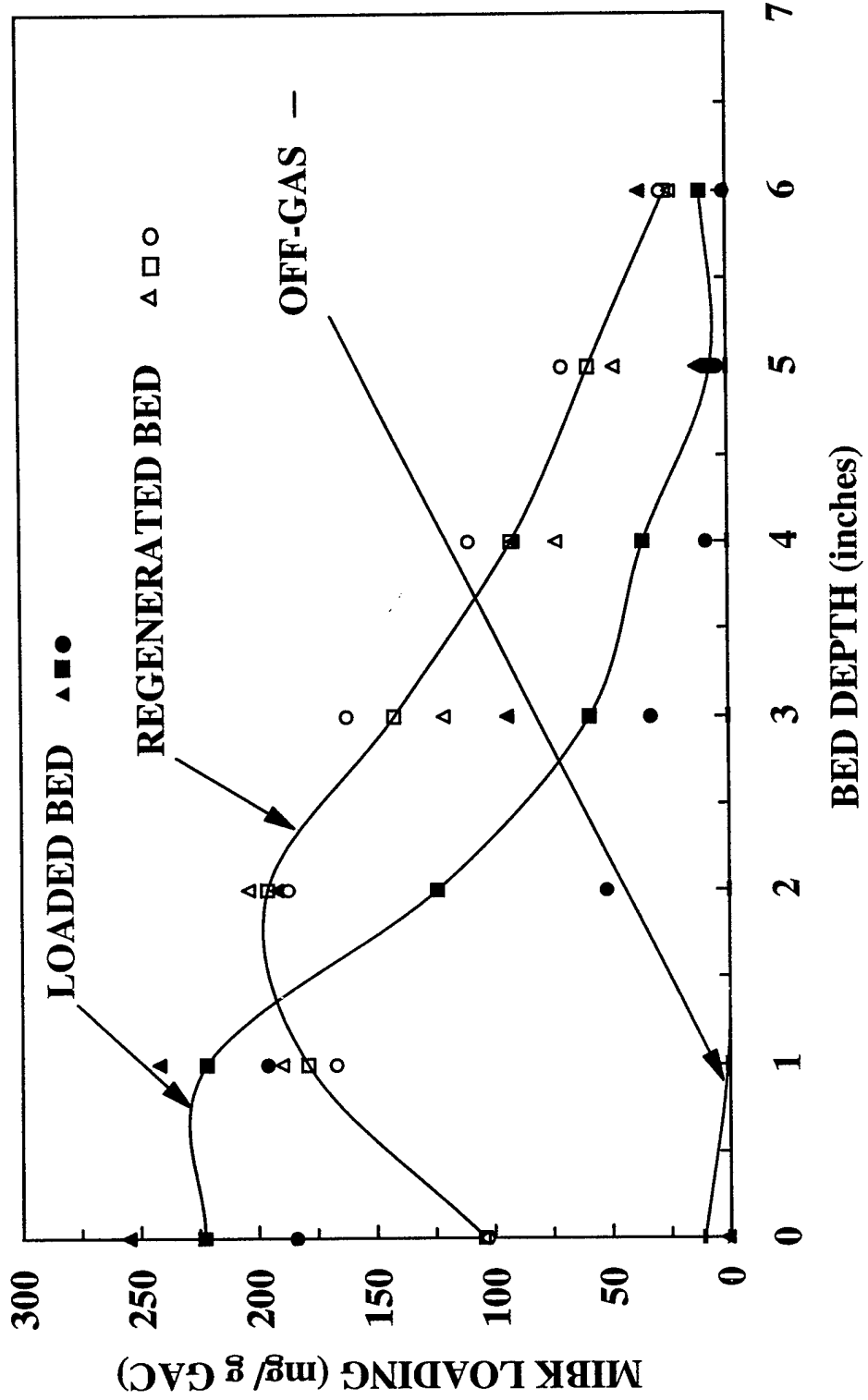

FIGURE 2-5: UV/O₃ REGENERATION ZONE IN GAC BED



**FIGURE 2-6: 24 HOUR UV/O₃ REGENERATION OF GAC
LOADED FOR 24 HOURS WITH 160 PPMV MIBK**



**FIGURE 2-7: REGENERATED GAC
EXTRACT CHROMATOGRAM**

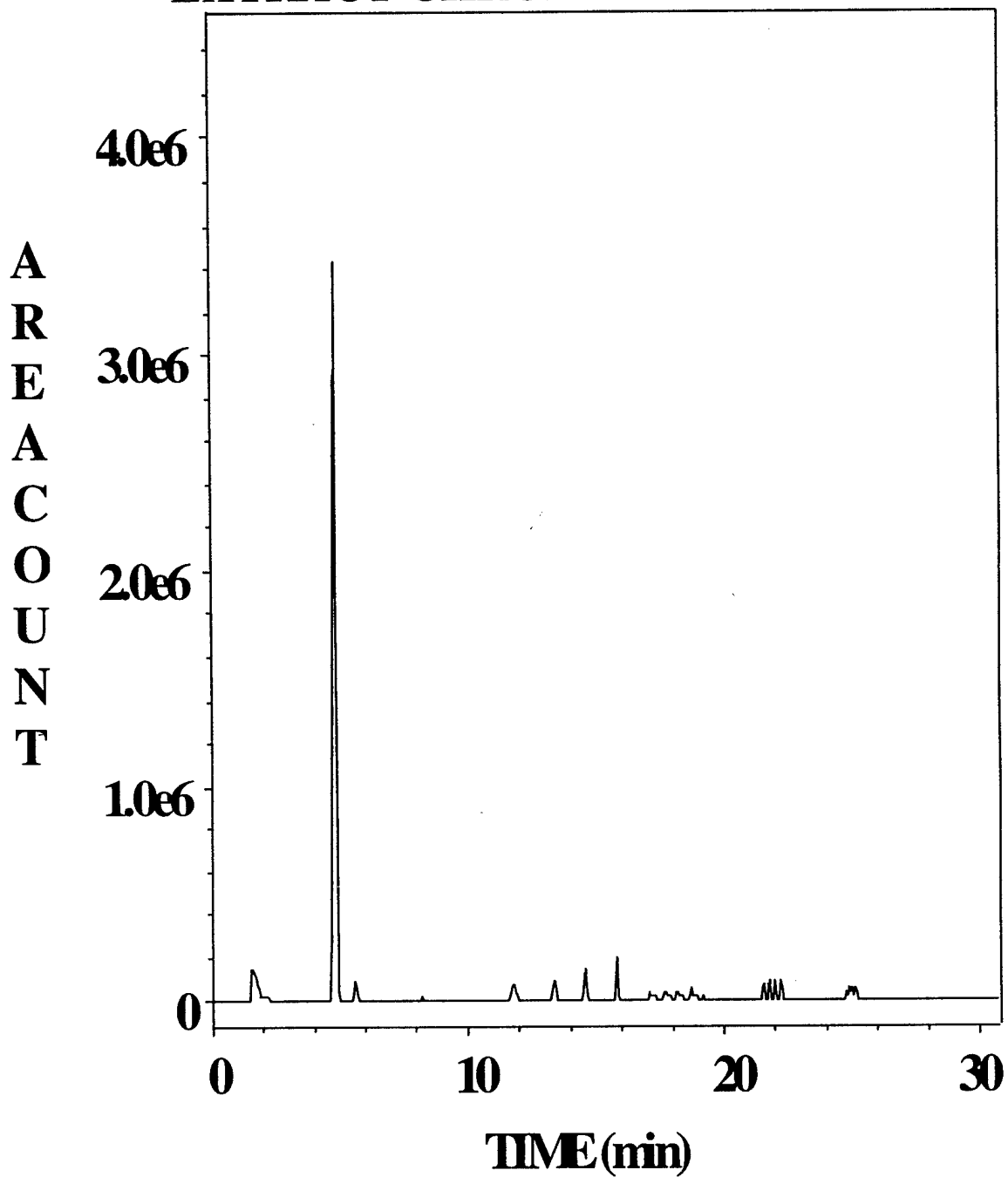

**FIGURE 2-8: OZONE PENETRATION IN 30 MINUTES
VERSUS DEPTH INTO GAC BED**

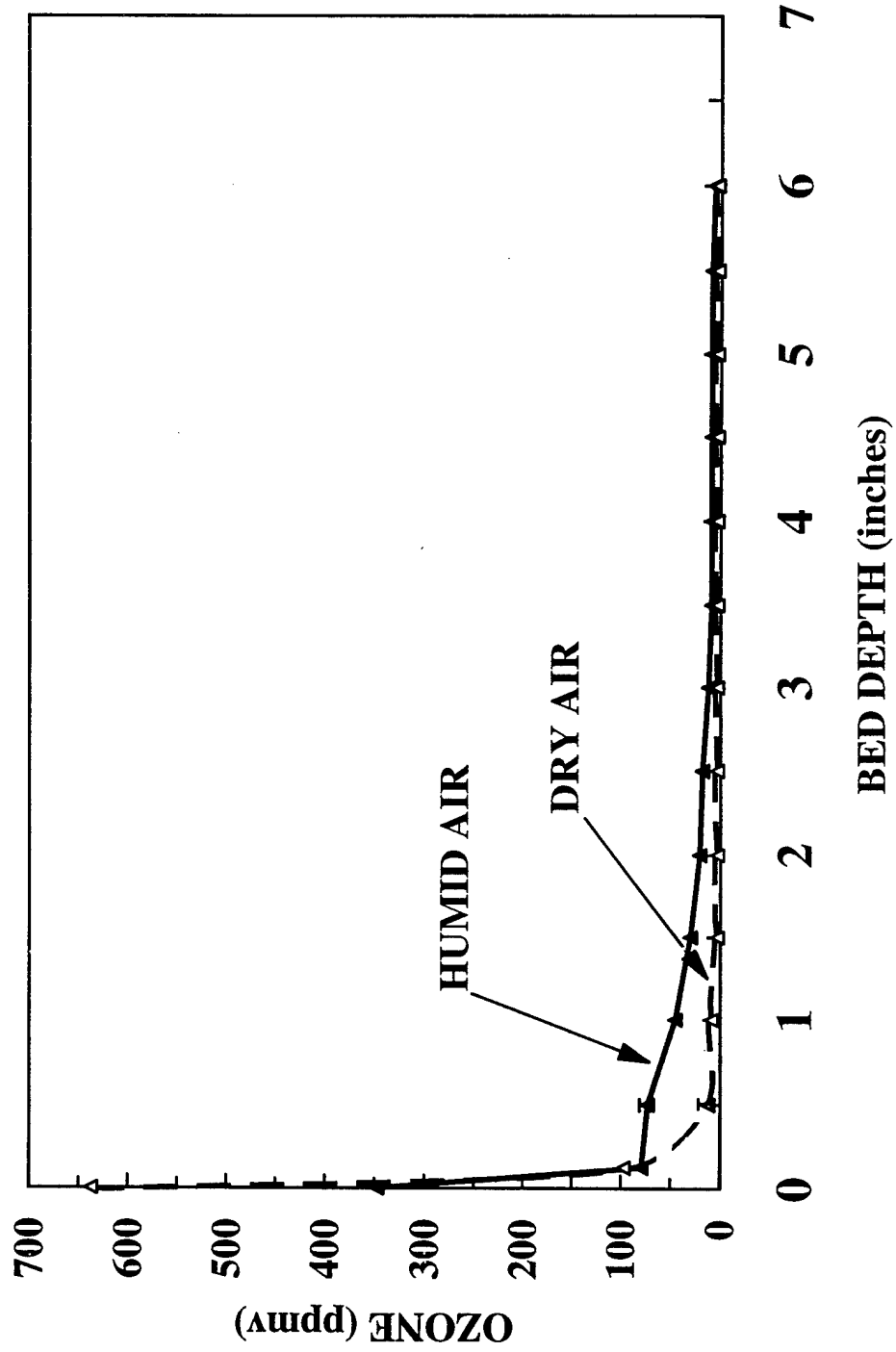

**FIGURE 2-10: TOTAL ADVANCED OXIDANT
PENETRATION VERSUS TIME INTO A GAC BED**

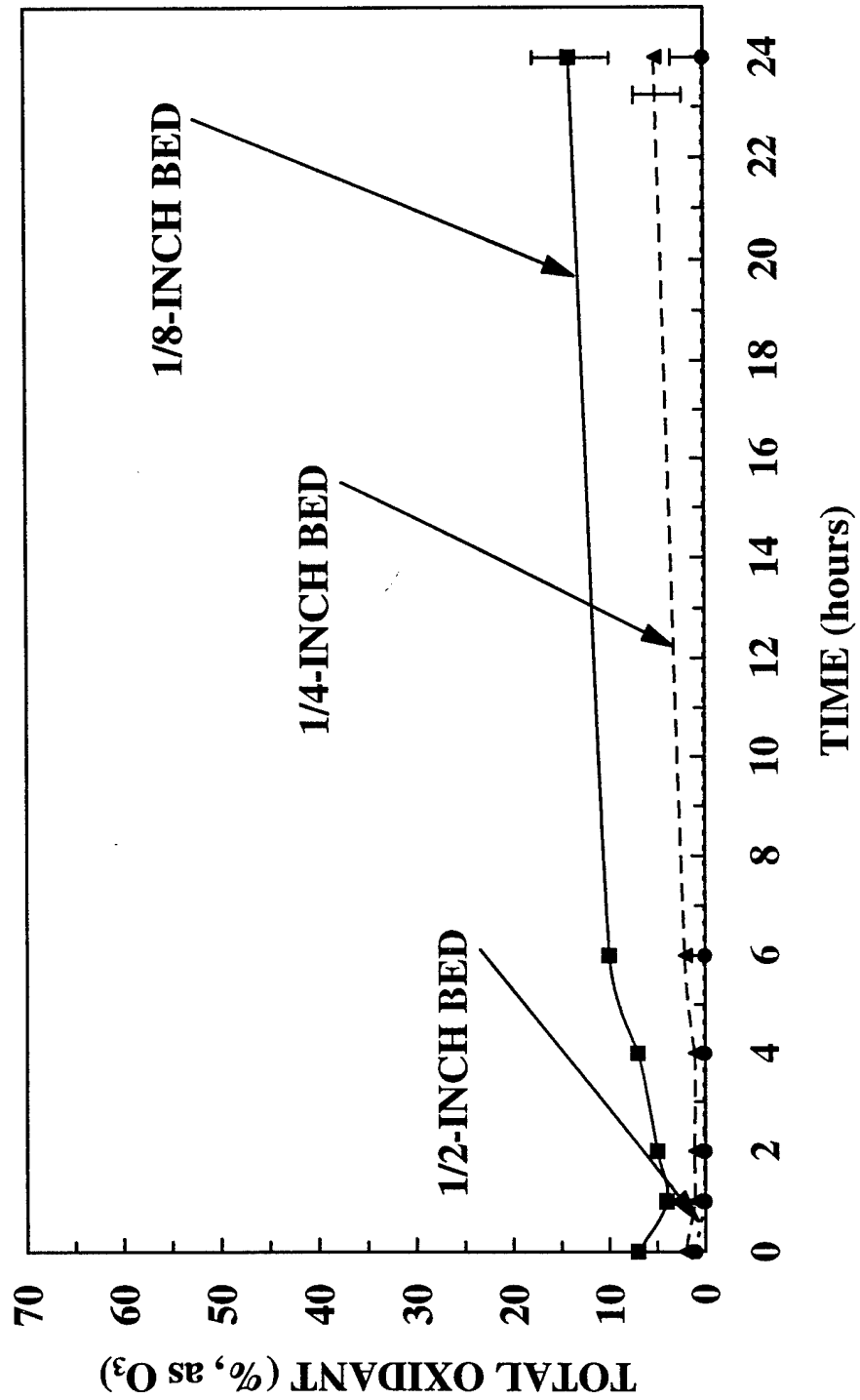

FIGURE 2-11: HUMID O₃ AND TOTAL OXIDANT PENETRATION VERSUS TIME THROUGH 1/8-INCH GAC

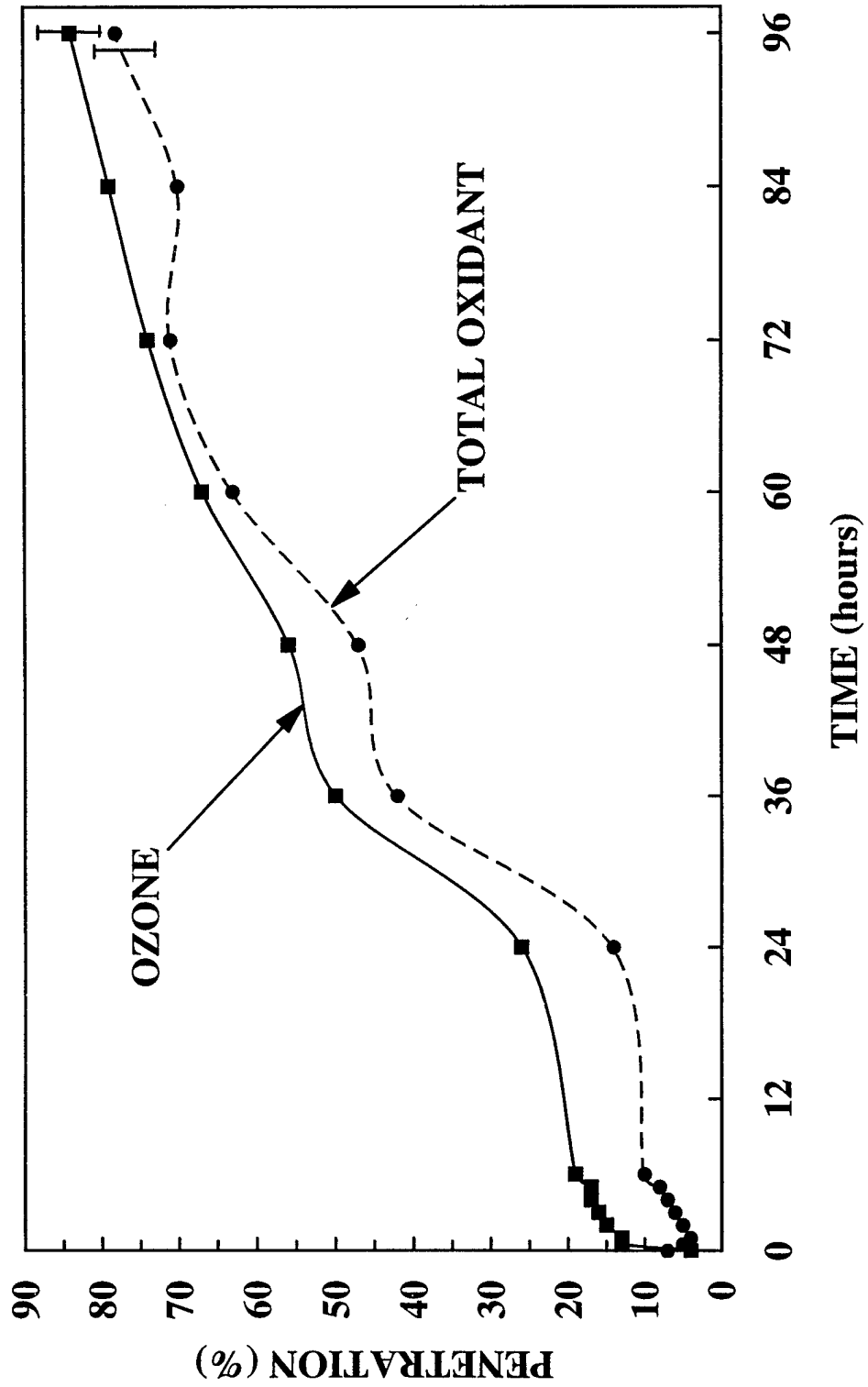

FIGURE 2-12: HUMID O₃ PENETRATION VERSUS TIME INTO 1/8-INCH GAC BED

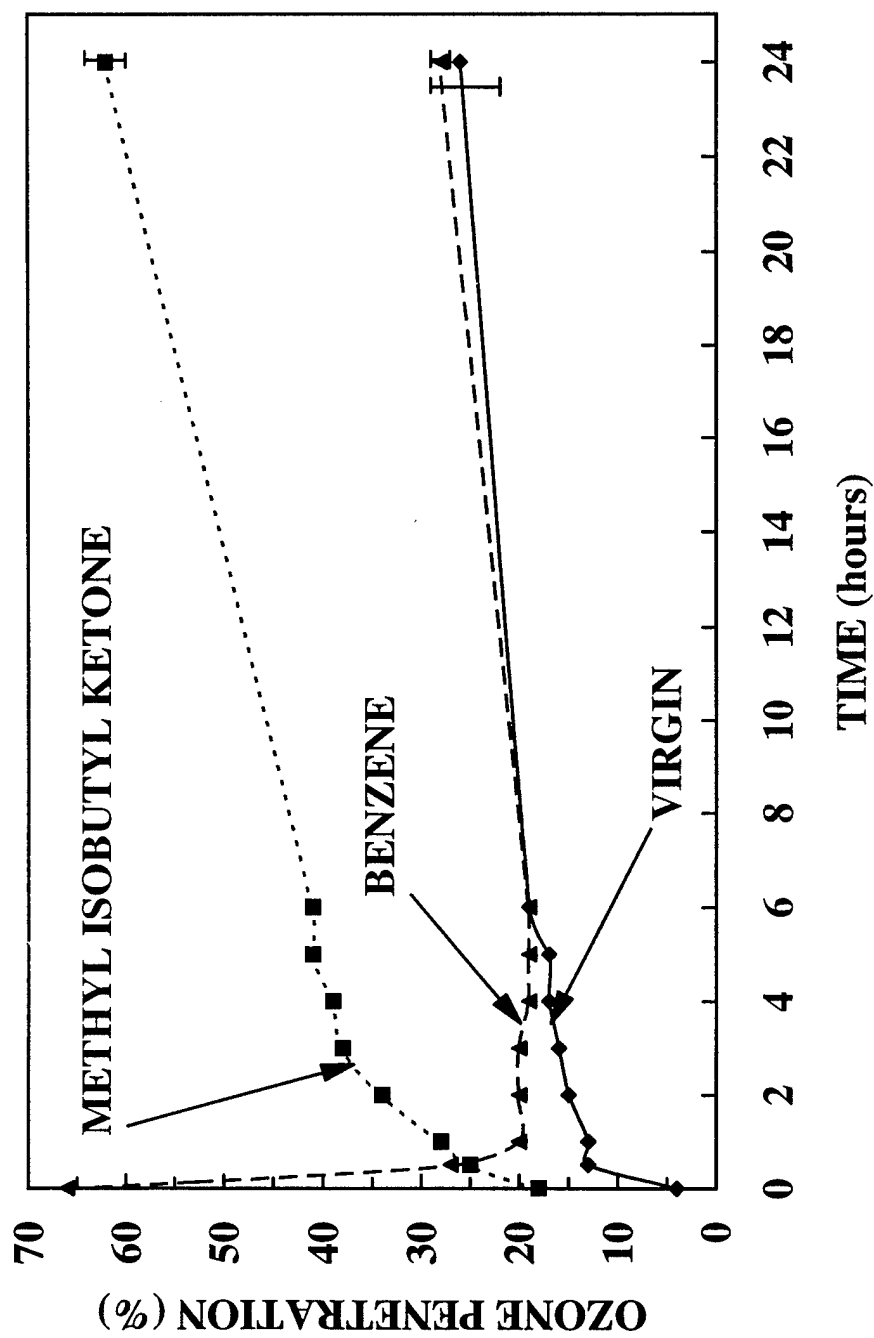

FIGURE 2-13: HUMID AIR TOTAL ADVANCED OXIDANT PENETRATION VERSUS TIME INTO 1/8-INCH GAC BED

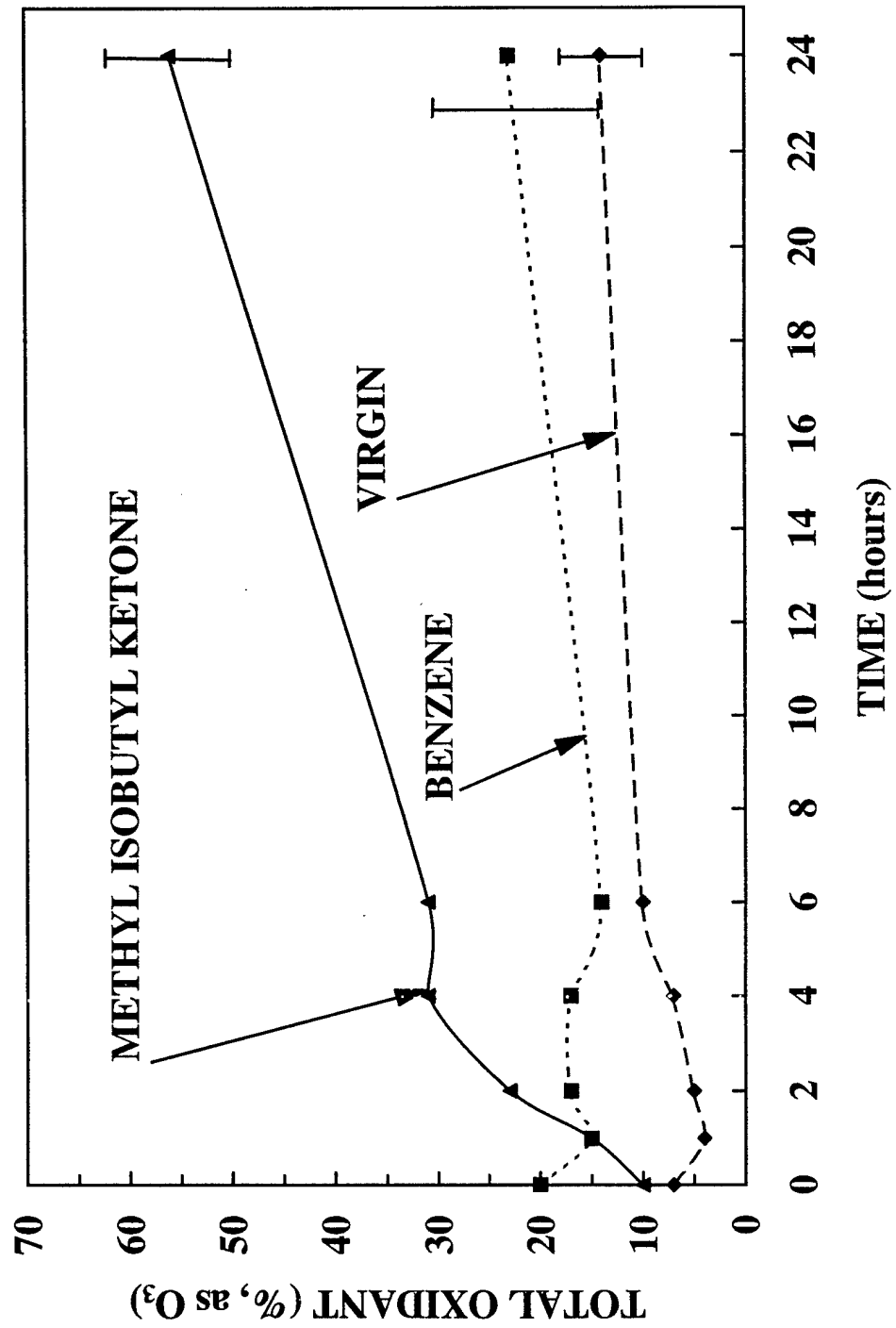

FIGURE 2-14: HUMID O₃ PENETRATION VERSUS TIME
INTO 1/8-INCH GAC BED

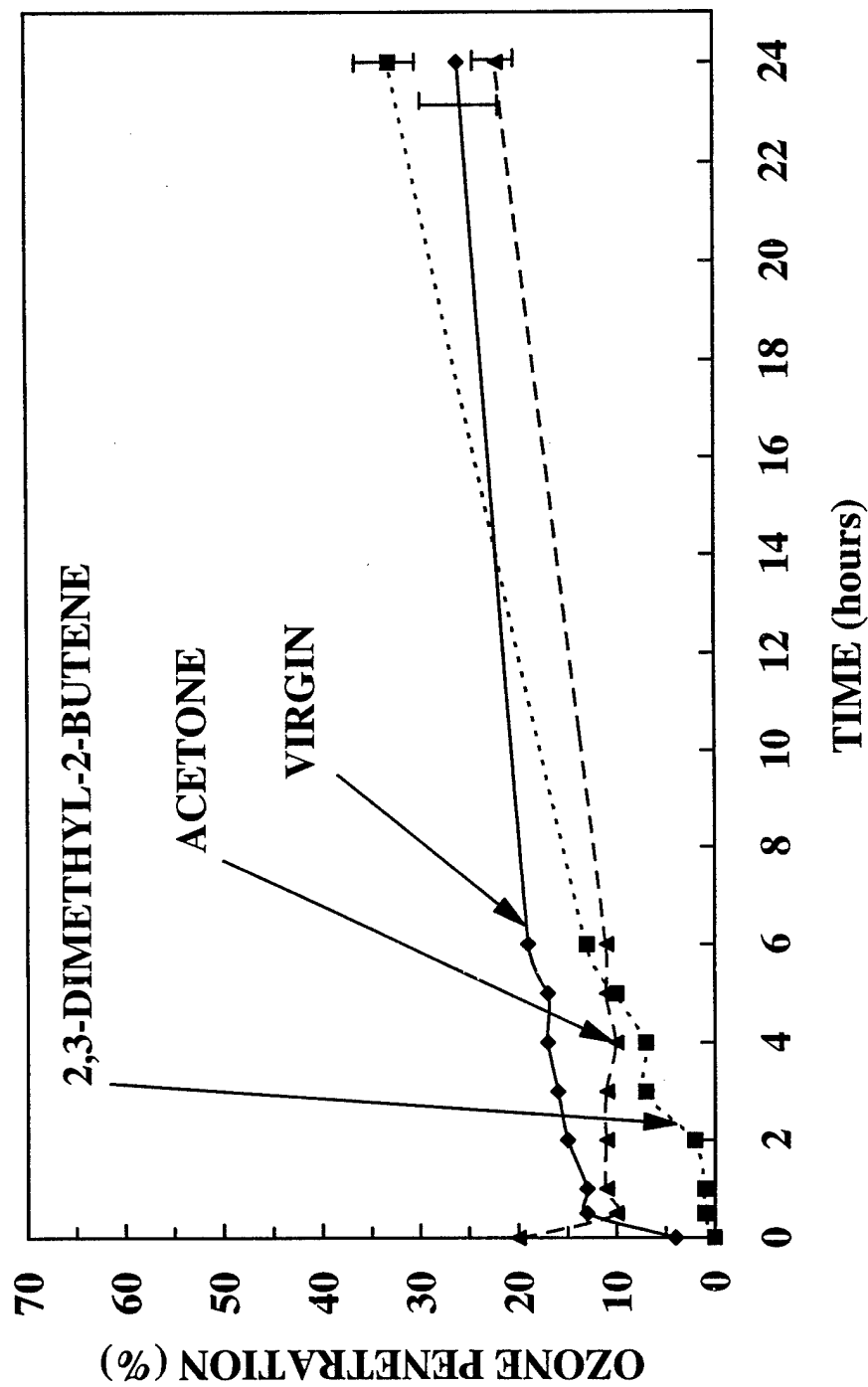
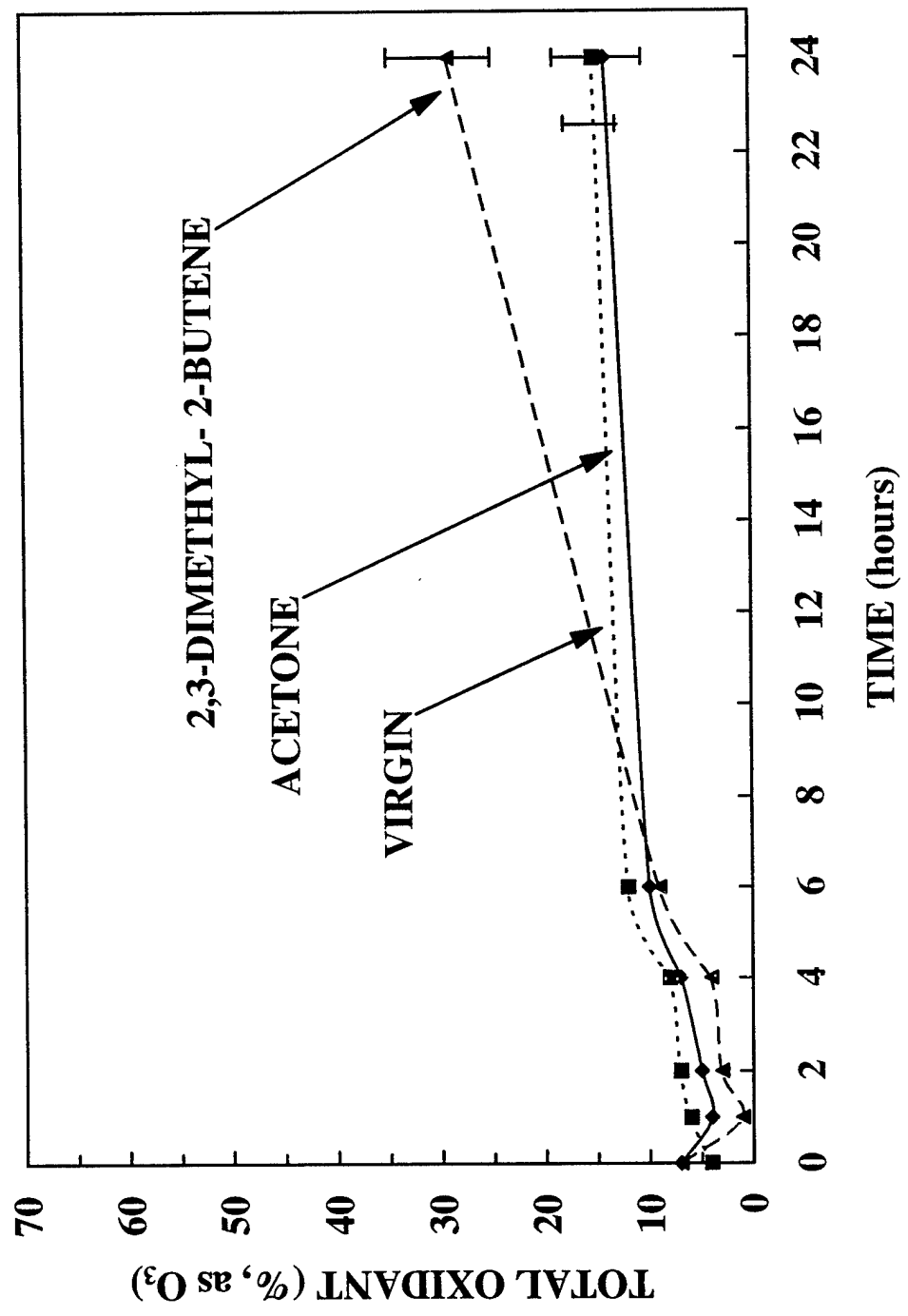

FIGURE 2-15: HUMID AIR TOTAL ADVANCED OXIDANT PENETRATION VERSUS TIME INTO 1/8-INCH GAC BED



CHAPTER 3

BIOFILM BIODEGRADATION KINETICS OF VOLATILE ORGANIC COMPOUNDS IN A GRANULAR ACTIVATED CARBON BIOFILTER

3.1 Abstract

In the modeling of biofilters for treatment of air-phase volatile organic compounds (VOCs), kinetic parameters play a central role in the development and application of the model. However, few published papers are available on the kinetic aspects of aerobic biodegradation of VOCs by a biofilm immobilized on an adsorbent matrix in air-phase reactors. The work described herein presents a technique for determining the kinetic parameters for biofilms suspended on GAC under a pseudo-steady state condition. The technique is then used to estimate the kinetic parameters for sequentially loaded and regenerated biofilters operated under different regeneration conditions.

3.2 Introduction

In recent years, biofiltration has received increasing attention as an air pollution control technique for volatile organic compounds. Biofiltration systems consist of microorganisms that are immobilized on a solid media through which a contaminated air stream passes. VOCs contained within this air stream are absorbed by the biofilm and degraded by the microorganisms. Numerous models have been proposed to represent biofilters and provide a fundamental basis for the design of new systems to ensure they

meet performance requirements. The critical design parameter in many of these models is the rate of reaction of VOC degradation by microorganisms within the filter. However, few published papers address the microbial kinetics of VOC degradation in a biofilm that is exposed to air phase contaminants. Most of the biodegradation kinetic work for air-phase biofilters that has appeared in the public literature employed biomass that was suspended in a liquid media in either a batch reactor or chemostat. In other cases, representative biodegradation rates were taken from tables compiled within the literature. In most cases, these biodegradation rates do not take into account the potential culture changes that may have occurred due to removing the microorganisms from a biofilter that has been used for treating air-phase VOCs, and then placing them in a radically different environment consisting of suspended microorganisms in a liquid media [Ottengraf and Van Den Oever, 1983; Leson and Winer, 1991; Shareefdeen *et al*, 1993; Tang *et al*, 1996]. These changes could potentially lead to results that do not accurately depict air-phase systems.

In contrast, numerous studies have recently been conducted to study the intrinsic surface kinetic constants in liquid-phase biofilms for application to wastewater treatment [La Cour Jansen and Harremoes, 1984; Jennings *et al*, 1976; Arvin *et al*, 1991 a,b; Gonenc *et al*, 1991; Cao and Alberts, 1995; Fox and Suidan, 1991; Heath *et al*, 1990, 1991]. The intrinsic rate may be defined as the inherent rate of microbial degradation as opposed to the overall surface degradation rate which may be contingent on mass transfer into and through the biofilm.

The objective of this study was to develop a method which could be used to determine the intrinsic kinetics of biofilms that are immobilized on GAC while the microorganisms degrade VOCs in the air-phase. A method was developed in which intrinsic kinetics may be determined by integrating the work of Harremoes [1976] and Jennings *et al.* [1976], Fox and Suidan [1991], and respirometry [Grady *et al.*, 1989; Naziruddin *et al.*, 1995] then adapting it to air-phase biofilms.

3.3 Literature Review

In modeling of biofilters presented by Ottengraf [1981], Shaferdeen *et al.* [1993], and Dehusses *et al.* [1995 a,b], biodegradation reaction rate orders and constants play a central role in the development and use of the model. Commonly, rate orders and constants are used which were determined using suspended growth reactors in a batch or chemostat mode of operation. As pointed out by Suidan and Fox [1991], this ignores potential changes in the microbial consortium due to changing the environment and removing the microorganisms from the biofilm, which could lead to kinetic parameters that are not representative of the biofilter system.

3.3.1 BIOFILM BIODEGRADATION KINETICS

A number of researchers have developed methods for determining the intrinsic kinetic constants of a biofilm in water treatment applications [La Cour Jansen and Harremoes, 1984; Arvin *et al.*, 1991 a,b; Gonenc *et al.*, 1991; Cao and Alberts, 1995; Fox

and Suidan, 1991; Heath *et al.*, 1990, 1991]. Harremoes [1976], Jennings *et al.* [1976] and Arvin [1991 a, b] have developed a model to determine the intrinsic kinetics of a biofilm in the liquid phase in a completely stirred tank reactor (CSTR). In this model the overall kinetics of the biofilter system were assumed to transition from zero-order to first-order as the concentration decreases. The intrinsic reaction rate of the microorganisms within the biofilm follows this well-known gradual transition, usually interpreted as the kinetics of enzymatic phenomena according to Monod or Micheals-Menton:

$$\mu = \mu_{\max} * C/(K_s + c) \quad (3-1)$$

where: μ = specific growth rate, time⁻¹

μ_{\max} = maximum specific growth rate, time⁻¹

C = concentration of growth-limiting substrate, mass/ unit volume

K_s = half-velocity constant, substrate concentration at one-half the maximum growth rate, mass/ unit volume

At bulk concentrations well above the half-saturation constant the intrinsic rate becomes zero order and at bulk concentrations well below the half-saturation constant the intrinsic rate becomes first order. When the intrinsic microbial kinetics within the biofilm are first order and the biomass is at a steady state, then the overall biofilter removal rate may also be described by a first order removal rate.

In the region of zero order microbial kinetics within the biofilm two conditions may be encountered: reaction limitation and diffusional limitation [Ottengraf, 1981]. In reaction limited situations there is no diffusional limitation in the wet biolayer, the entire depth of the biolayer is fully active, and the degradation rate is controlled by the reaction

rate and the bulk surface reaction order is zero order. Under diffusionally limited conditions, the degradation rate is controlled by the diffusion through the biolayer. When the biofilm is only partially penetrated the bulk surface reaction order is half-order; this approximation has been shown to represent a wide variety of experimental data for biofilms in CSTRs [Harremoes, 1976; La Cour Jansen and Harremoes, 1984; Arvin, 1991 a,b; Heath *et al*, 1990,1991]. Using this approach the overall kinetic rate constants for the bulk surface can be related to the intrinsic biofilm rate constants by the following equations [La Cours Jansen and Harremoes, 1984; Arvin, 1991 a,b; Heath *et al*, 1990,1991]:

$$\text{First Order: } r_{1,a} = k_{1,a} * C \quad (3-2)$$

$$\text{Half Order: } r_{1/2,a} = k_{1/2,a} * C^{1/2} \quad (3-3)$$

$$\text{Zero Order: } r_{0,a} = k_{0,a} \quad (3-4)$$

and

$$k_{1,a} = k_{1,f} * \delta * \epsilon = k_m / K_s * \delta * \epsilon \quad (3-5)$$

$$k_{1/2,a} = (2 * D * k_m)^{1/2} \quad (3-6)$$

$$k_{0,a} = k_m * \delta \quad (3-7)$$

where:

C:	substrate concentration (mg m^{-3})
$r_{1,a}$, $r_{1/2,a}$, and $r_{0,a}$:	1st, 1/2, and 0 order surface removal rates ($\text{mg m}^{-2}\text{hr}^{-1}$)
$k_{1,a}$,	1st order rate constant (m hr^{-1})
$k_{1/2,a}$,	1/2 order rate constant ($\text{mg}^x\text{m}^{-x}\text{hr}^{-1}$)
$k_{0,a}$:	0 order rate constant ($\text{mg m}^{-2}\text{hr}^{-1}$)

$k_{1,f}$:	first order intrinsic reaction rate in the biofilm (hr^{-1})
k_m :	maximum substrate utilization rate ($\text{mg m}^{-3}\text{hr}^{-1}$)
K_s :	Monod constant (half saturation constant) (m^3mg^{-1})
δ :	biofilm thickness (m)
ϵ :	efficiency factor
D	diffusional coefficient of the VOC in the biofilm (m^2hr^{-1})

δ must be determined experimentally, then ϵ can be found through the simultaneous solution of the following equations [Arvin 1991 a, b]:

$$\epsilon = \frac{\tanh \alpha}{\alpha} \quad \text{where} \quad \alpha = \sqrt{\frac{k_{1,a} * \delta}{\epsilon * D}} \quad (3-8)$$

The efficiency factor ϵ represents the ability of the substrate to penetrate the biofilm as an effective concentration modified by diffusion and biological degradation. Once ϵ is determined, the Monod constant (K_s) may be estimated from equations 3-4 and 3-6. In this manner the intrinsic kinetic parameters may be determined using a reactor which approximates well mixed conditions.

3.3.2 BIODEGRADATION KINETICS OF BIOFILMS ATTACHED TO ADSORBENT MATERIALS

Fox and Suidan [1991] have developed a method for overcoming confounding influences when determining degradation rates that are achieved by biofilms that are immobilized on a solid matrix that has a high adsorption capacity. This confounding influence is created by substrate adsorbing and desorbing from the adsorbent. If this

sorption is not taken into account it may have a significant impact on the parameters determined through experimental studies. In these cases it is difficult to measure the amount of substrate consumed due to the adsorption or desorption of the compound by the adsorbent based on changing equilibrium conditions during experimental investigations.

Fox and Suidan [1991] proposed a fed-batch method in which a large mass of adsorbent was pre-charged in a reactor with the compound of interest at a specific equilibrium condition. This provided a large mass of organic compound, which was much greater than the substrate utilized during the test, to be desorbed from the GAC. The desorption maintained a concentration in the liquid-phase approximately equal to the concentration at which the GAC was loaded since the change in total mass of substrate was negligible. A small mass of bioactive solid was then added to this precharged reactor. As the microorganisms degraded the compound and removed it from the water more was desorbed from the adsorbent. The desorption occurred in a semi-continuous manner that created an addition of substrate at a rate approximately equivalent to the biological utilization, maintaining an essentially constant concentration in the liquid phase. If the mass of pre-charged adsorbent is large enough and the time of the experiment short enough, then the adsorbent can maintain a constant concentration, which allows accurate determination of the rate parameters.

In the case of Fox and Suidan [1991] they were investigating anaerobic degradation of 3-ethylphenol and orthochlorophenol. To determine the degradation rates, they measured the production of methane gas. Thus the GAC with adsorbed substrate

acts as both a source of substrate and as a buffer to maintain a constant substrate concentration. The technique avoids the potential impact of removing the biomass from the biofilm in determining kinetic parameters. This method also measures the substrate utilization rate at a specific substrate concentration which is maintained for the duration of the experiment. Experiments conducted at a constant concentration eliminate the requirement for complex computational methods necessary to determine kinetic parameters for batch experiments. However, a limitation of this method is that the substrate utilization rate must be indirectly determined by measuring the rate of product formation.

3.3.3 DETERMINATION OF BIODEGRADATION KINETICS THROUGH RESPIROMETRY

Respirometry, or oxygen consumption, has been shown to generate kinetic parameter estimates for aerobic microorganisms comparable to those obtained with other, more classical techniques [Grady *et al*, 1989; Naziruddin *et al*, 1995]. Respirometric experiments have been conducted in sealed batch reactors which contain a substrate, microbial culture and a nutrient solution. During respirometry tests, biodegradation of a substrate by a culture produces CO₂ which is removed from the sealed reactor by a CO₂ adsorbent. The removal of CO₂ results in a pressure drop, which in turn is equalized by the addition of oxygen. This addition of oxygen is measured and recorded. Thus, respirometry uses the production of CO₂ to indirectly determine oxygen consumption [Young *et al*, 1965; Young and Baumann, 1976]. If microbial activity is solely

responsible for the consumption of oxygen, then cumulative oxygen uptake versus time can be directly related to biomass growth and substrate use [Grady *et al*, 1989; Naziruddin *et al*, 1995].

The kinetics of biodegradation may be expressed as the rate of substrate removal:

$$\frac{dC}{dt} = -\frac{\mu}{Y_b} X \quad (3-9)$$

where c is substrate concentration, μ is specific growth rate, X is the biomass concentration, and Y_b is the biomass yield. The product formation may be correlated to the substrate consumption by the following relationship:

$$\frac{dP}{dt} = Y_p \left(-\frac{dC}{dt} \right) \quad (3-10)$$

where P is the product concentration and Y_p is the product yield.

The specific growth rate is given by either Monod kinetics as described previously or Haldane-Andrews kinetics when the compound is inhibitory to its own biodegradation:

$$\mu = \mu_{\max} \frac{C}{K_s + C + \frac{C^2}{K_i}} \quad (3-11)$$

where μ is the specific growth rate, μ_{\max} is the maximum specific growth rate, C is the substrate concentration, K_s is the half-saturation coefficient, and K_i is the inhibition coefficient.

The kinetic data may be evaluated from the respirometry results based on the concept of oxygen consumption as an energy balance [Grady *et al*, 1989; Naziruddin *et al*, 1995]. This assumes that all of the electrons available in a substrate undergoing

biodegradation must either be transferred to the terminal electron acceptor or be incorporated into new biomass or microbial products. Grady *et al* [1989] have used this concept to determine kinetic parameters, and they have compared them to more traditional estimations, such as, soluble chemical oxygen demand (SCOD) removal, dissolved organic carbon (DOC) removal, biomass growth, and ^{14}C removal, with favorable results.

As discussed below, the author has built on the approach of Fox and Suidan [1991] to develop a technique for investigation of biomass from air-phase biofilters. Specifically, biomass attached to GAC degrading VOCs from the gas-phase. The data was then analyzed using the principles of kinetic rate determination by respirometry [Grady *et al*, 1989; Naziruddin *et al*, 1995] and the biofilm modeling method of Harremoes [Harremoes, 1978; La Cour Jensen and Harremoes, 1984; Arvin, 1991] and Jennings [1976].

3.4 Materials and Methods

3.4.1 BIOFILM/GAC MATRIX SOURCE

The biologically active GAC used in the fed-batch reactors for this study was taken from one of two sequentially loaded and regenerated GAC biofilter systems that had been operating for over 12 months. This bioactive GAC source ensured that the microorganisms were acclimated to the substrate. Each GAC biofilter consisted of two 1-1/2-inch PVC columns that contained 6 inches of 4 X 7 mesh coconut shell GAC

manufactured by Barnebey Sutcliffe Corporation (Columbus, OH). The systems were seeded with filamentous microorganisms from Terra-Aqua Environmental Systems air pollution control systems operating at a field site. The seeding of the biofilter was conducted by distributing 5 g of GAC coated with filamentous microorganisms from the TAES field system in virgin GAC as the GAC was added to the PVC column. The systems were operated in the following manner. One column was on-line treating a humidified air stream which was laden with MIBK at a specific concentration. The second column was regenerated with the effluent from the column recycled through the on-line column. The regeneration air stream was humidified air for one of the seeded biofilter systems. The second seeded biofilter system was regenerated with a humidified air stream which was passed through an UV reactor generating a ozone concentration of ~ 200 ppm. Details of the operation of the GAC biofilters are presented in Chapters 4 and 5.

3.4.2 EXPERIMENTAL SYSTEM

An experimental system was developed to provide a well mixed reactor (Figure 3-1). The reactor consisted of a 115 mL glass vessel fitted with a glass cap by a ground glass fitting. The reactor had a glass tube inlet port at the bottom and the cap had two glass tube outlet ports. The glass tube ports were stoppered with red rubber sleeve serum stoppers. These stoppered glass tube ports allowed air tight connections to be made with syringe needles and samples to be withdrawn by gas tight syringes. Mixing was performed by upflow recirculation through the reactor. Tygon tubing (fuel and lubricant

type) was selected for its low diffusivity with respect to CO_2 and its suitability for use with hydrocarbons and inserted into the reactor through the serum stoppers via a syringe needle. A peristaltic pump was used to generate a flow of 100 mL/min, creating a complete turnover of air within the reactor almost once every minute. Virgin GAC was used as a reservoir for MIBK and was supported by 1/4-inch thick stainless steel flow straightener. A 1/2-inch glass ring lifted the stainless steel flow straightener off the base of the reactor and enhanced uniform flow distribution into the GAC. Room temperature consistently remained between 19 and 21 °C throughout these experiments, however extremes as high as 24 and low as 17 °C were occasionally encountered.

The reactor was filled with 15 g (dry) of virgin GAC which had been soaked in distilled water for a day, to provide humidity within the reactor. A specified amount of MIBK was then added to the reactor. The MIBK added partitioned between the air and solid (GAC) phase according to equilibrium isotherm. This generated a desired air-phase concentration which was maintained through the course of the experiment by the reservoir of MIBK associated with the adsorbed fraction. The adsorbed mass was much larger than the mass consumed by degradation. The mass degraded from the air-phase was replenished by transfer into the air-phase from the GAC by desorption. Thus these beds maintained batch-flow conditions with a MIBK concentrations that remained at a fairly constant level as the MIBK was biodegraded to CO_2 . The reactor was then purged for 5 minutes with a mixture of 60 % N_2 and 40 % O_2 , by volume. This mixture contained two main components of air, but CO_2 had been removed to trace levels, in order to facilitate accurate measurements of CO_2 production, as discussed below.

Recirculation was started at a flow rate of 100 mL/min and the GAC was allowed 2 days to adsorb the MIBK and reach equilibrium. Previous tests had indicated that adsorption equilibrium could be reached within several hours under such loading conditions [Singh, 1995] After 2 days the reactor was charged with $2.005 \pm .005$ g of wet biologically active GAC then purged with N_2/O_2 again for 5 minutes. This 2 g of wet GAC had a dry mass of $1.585 \pm .004$ g. CO_2 generation and MIBK concentration were then monitored via Gas Chromatography periodically during the experiment.

3.4.3 ANALYTICAL PROCEDURES

Analysis of CO_2 was performed with a Hewlett-Packard 5890 Series II gas chromatograph (Valley Forge, PA) that was equipped with a thermal conductivity detector (TCD). Separation was achieved with a 10 ft 1/8-inch stainless steel column packed with Haysept T adsorbent (Supelco, Inc., Bellefonte, PA). The carrier and reference gases were helium.

The fed-batch reactor recirculation loop was designed in a manner which allowed the flow to be diverted through a six port gas sampling valve on the GC/TCD prior to returning to the reactor when sampling was required (Figure 3-1). The recirculation flow was passed through the gas sampling valve for 2 minutes prior to sample injection into the GC/TCD.

Analysis of MIBK in the air-phase was conducted using a Hewlett-Packard 5890 Series II gas chromatograph (Valley Forge, PA) that was equipped with a flame ionization detector (FID). A 0.53 mm ID by 30 m long Supelcowax 10 column (Supelco

Inc., Bellefonte, PA) was used with He as the carrier gas at a flow rate of 6 mL/min. A 25 μ L sample of air was removed from the reactor using a 1.0 mL Pressure-Lok syringe (Precision Sampling Corp, Baton Rouge, LA) and injected into the GC/FID.

3.5 Results and Discussion:

3.5.1 BIOFILM KINETICS FOR THE UNOZONATED GAC BIOFILTER

SAMPLE

The rate of CO₂ generation via MIBK degradation by a biofilm supported on a GAC matrix was measured at six different mass loadings within the fed-batch reactor. The six mass loadings were: 7.04 g, 4.16 g, 2.88 g, 2.16g 1.44 g, and 0.32 g of MIBK corresponding to 61.22 mg/mL, 36.17 mg/mL, 25.04 mg/mL, 18.78 mg/mL, 12.52 mg/mL, and 2.78 mg/mL of MIBK per ml of reactor volume. These mass loadings produced the following equilibrium air-phase MIBK concentrations: 8440 ppm, 3440 ppm, 2010 ppm, 570, ppm, 135 ppm, and 35 ppm. The CO₂ generation versus time is shown for these conditions in Figure 3-2 and 3-3. Each CO₂ generation rate has been corrected for increases in CO₂ measured within the system during control runs. Control runs were conducted at each operating condition. During the control runs 15 g (dry) of GAC was prepared in the same manner as the experimental runs, however the 2 g of biologically active GAC was not added to the reactor. Then the identical experimental method was employed for these reactors and the CO₂ concentration was monitored versus time. The y-axis depicts the CO₂ concentration in ppm and the x-axis shows time in

hours. Figure 3-2 and 3-3 show that over the time period of 6 to 48 hours the CO_2 produced increased linearly with time for each air-phase concentration investigated. The coefficients of determination (R^2) for these lines were 0.90 to 0.998 for all but two set of data, and was equal to or greater than 0.79 for these sets as indicated for each line on the plot.

During the first 6 hours the CO_2 concentration increased at a rate much more rapidly than during the following 42 hour interval. This time frame was assumed to be an equilibration period required due to the addition of the bioactive GAC from an air regenerated sequentially loaded and regenerated biofilter operated under the following conditions: air-phase MIBK concentration of 35 or 115 ppm with an empty bed contact time of 37 or 148 seconds, respectively. The different operating conditions for the sequentially loaded and regenerated GAC biofilter were found to have no effect on the CO_2 generation rate from 6 to 48 hours for a given condition in the fed-batch reactor. During the first six hours the air-phase concentration within the fed batch reactor dropped from the initial value to a value which remained essentially constant throughout the remainder of the experiment (Figure 3-4). This pseudo steady-state condition was used as the air-phase MIBK concentration for all subsequent calculations.

The CO_2 concentration versus time for each air-phase concentration was used to determine a CO_2 generation rate. This rate was determined using a linear regression, through a y-intercept of 0, of the CO_2 concentration versus time. The slope of the line corresponds to the generation rate. Each data point used in the linear regression to

determine the slope of the line was the average of replicate experiments. The coefficient of determination for each line is shown in Figures 3-2 and 3-3.

In Figure 3-5 the CO₂ generation rate (as determined for each condition from the slope of the line in the concentration versus time figures) was plotted versus the air-phase MIBK concentration that was continually monitored during the experiment by direct injection of air samples into the GC/FID.. This figure shows that the CO₂ generation rate increased with increasing concentration until the air-phase concentration reaches approximately 3010 ppm. As the air-phase concentration increased above 3010 ppm the CO₂ generation rate began to gradually decline and the rate at 8500 ppm was 77% of the rate at 3010, indicating that this inhibition was slight. The 8500 ppm MIBK concentration may be compared to a saturated MIBK concentration of 26,000 ppm at 25 °C. This pattern was consistent with a Haldane-Andrews-type kinetic model for microbial degradation in which the substrate becomes inhibitory to the degradation rate at elevated concentrations.

A best fit analysis was determined using the generation rates, air-phase MIBK concentration, and the Haldane-Andrews model. The analysis was done using a Microsoft Excel spreadsheet and produced in the following values for the Haldane-Andrews coefficients: k_{max} = 250 ppm CO₂/HR*g Biofilter Material, K_s = 675 ppm MIBK, and K_i = 7040 ppm MIBK. Where k_{max} is the apparent rate constant normalized on a per gram of biofilter material basis, which incorporates the biomass concentration into the rate constant assuming a uniform biomass concentration ($k_{max} = \mu_{max} * X/Y_b$). These values were used to plot the model line in Figure 3-5.

At bulk concentrations below the half-saturation constant the rate becomes first order. Most industrial applications of the air-phase GAC biofilters investigated in this study treat contaminated streams at less than 200 ppm of VOC. Therefore, the first order rate constant was of most interest and a linear regression was performed in the region below the half-saturation constant to determine the rate constant. Figure 3-6 shows a linear regression in the region of interest resulting in a first order rate constant of $0.24 \text{ hr}^{-1} * (\text{g biofilter material})^{-1}$.

The decline in the CO_2 generation rate indicated that the substrate (MIBK) became inhibitory to biological degradation at concentrations above 3010 ppm. The biofilters investigated in this study treated waste streams with concentrations well below this inhibitory effect (maximum concentration 150 ppm). The maximum concentration studied was selected based on the maximum expected concentration in actual field operations. However, the slight inhibitory effect must be considered for any application in which the expected concentration of MIBK in the waste stream may reach the order of 3000 ppm. The Haldane-type kinetics observed for MIBK also demonstrates the need for determining the kinetic parameters for any VOC for which biofiltration may be considered. However, even at 8500 ppm MIBK there was only an approximately 23% reduction in rate compared to the maximum rate. Therefore, biofiltration will still provide effective treatment as long as the inhibitory effect was taken into consideration during design of the application. A VOC may potentially have an inhibitory effect on biodegradation at concentrations low enough to effect biofilter efficiency.

3.5.2 COMPARISON OF UNOZONATED GAC BIOFILTER KINETICS WITH THE OZONATED BIOFILTER SAMPLE

A sample of GAC biofilter material from the ozone/advanced oxidant regenerated sequentially loaded and regenerated GAC biofilter was evaluated by fed-batch reactor kinetic studies to determine the kinetic parameters under these conditions. This investigation was conducted primarily for two reasons, first to indicate whether the microbial community was different under ozonated conditions. Secondly, to determine the kinetic parameters for modeling purposes for the ozonated system. As Figure 3-7 shows, CO₂ production versus time was comparable for both the ozonated and unozonated conditions. Both biofilters were seeded using the same field sample of bioactive GAC. These results suggests that the ozone did not selectively alter the microbial kinetics at this concentration of MIBK. Therefore, the kinetic parameters determined for the unozonated sequentially loaded and regenerated GAC biofilter may also be used for the ozonated system.

3.5.3 ESTIMATION OF SUBSTRATE UTILIZATION PARAMETERS

The CO₂ generation rates determined via the fed-batch reactor experiments may be used to estimate the substrate (MIBK) degradation rate assuming that all the carbon consumed from the substrate was converted into biomass and products. No product other than CO₂ was identified with the analysis conducted. GC/FID analysis was performed on the CS₂ extract of the GAC from the fed-batch reactor. This examination was also conducted for excess water found in the bottom of the reaction vessel and in both

instances no other compounds were identified. GC/TCD investigation was used to determine products in the air-phase and only CO₂ was found.

The preceding information may be combined with a predicted biomass yield to calculate a product or CO₂ yield. A review of the literature has shown that for a wide variety of aerobic microbial communities under conditions as diverse as suspended growth to biofilms the biomass yield falls within the range of 0.33 to 0.46 mg VSS/mg substrate [Grady *et al* 1989, Naziruddin *et al* 1995, Arvin 1991]. The average within this range was 0.4. If 0.4 was chosen to represent the biomass yield and all the carbon in MIBK was assumed to be converted into CO₂ and biomass the product yield would be 0.6. If the value of 0.6 was used with equation 3-10 the kinetic parameters for biodegradation of MIBK then become $k_{max} = 25$ ppm MIBK/HR*g Biofilter Material, $K_s = 1230$ ppm MIBK, and $K_i = 7380$ ppm MIBK. These values correspond to an apparent first order rate constant, from Figure 3-6 of $k_{1,a} = 0.024$ hr⁻¹ * (g Biofilter Material)⁻¹.

3.6 Summary and Conclusions

A fed-batch technique was used to determine kinetic parameters for biofilter material consisting of a biofilm supported on a GAC matrix that degraded MIBK supplied to the biofilm from the air-phase. CO₂ concentration was measured as a function of time and produced a linear fit with coefficients of determination (R^2) of 0.90 to 0.998 for all but two sets of values and R^2 of equal to or better than 0.79 for these sets. The slopes of these lines were used to determine generation rates which were plotted

versus MIBK air-phase concentration. This resulted in a plot which could be modeled using the Haldane-Andrews kinetics. A best fit analysis was conducted that produced the following kinetic parameters for CO₂ generation $k_{\max} = 250 \text{ ppm CO}_2/\text{HR} \cdot \text{g Biofilter Material}$, $K_s = 675 \text{ ppm MIBK}$, and $K_i = 7040 \text{ ppm MIBK}$. The CO₂ generation rates were then used to estimate MIBK degradation rates resulting in the following degradation kinetic parameters $k_{\max} = 25 \text{ ppm MIBK}/\text{HR} \cdot \text{g Biofilter Material}$, $K_s = 675 \text{ ppm MIBK}$, and $K_i = 7040 \text{ ppm MIBK}$. A first order rate constant was estimated for CO₂ generation by linear regression of the values below the half-saturation constant resulting in $0.24 \text{ hr}^{-1} \cdot (\text{g biofilter material})^{-1}$. This corresponds to a MIBK first-order degradation rate of $0.024 \text{ hr}^{-1} \cdot (\text{g biofilter material})^{-1}$.

FIGURE 3-1: FED-BATCH GAC BIOFILTER APPARATUS

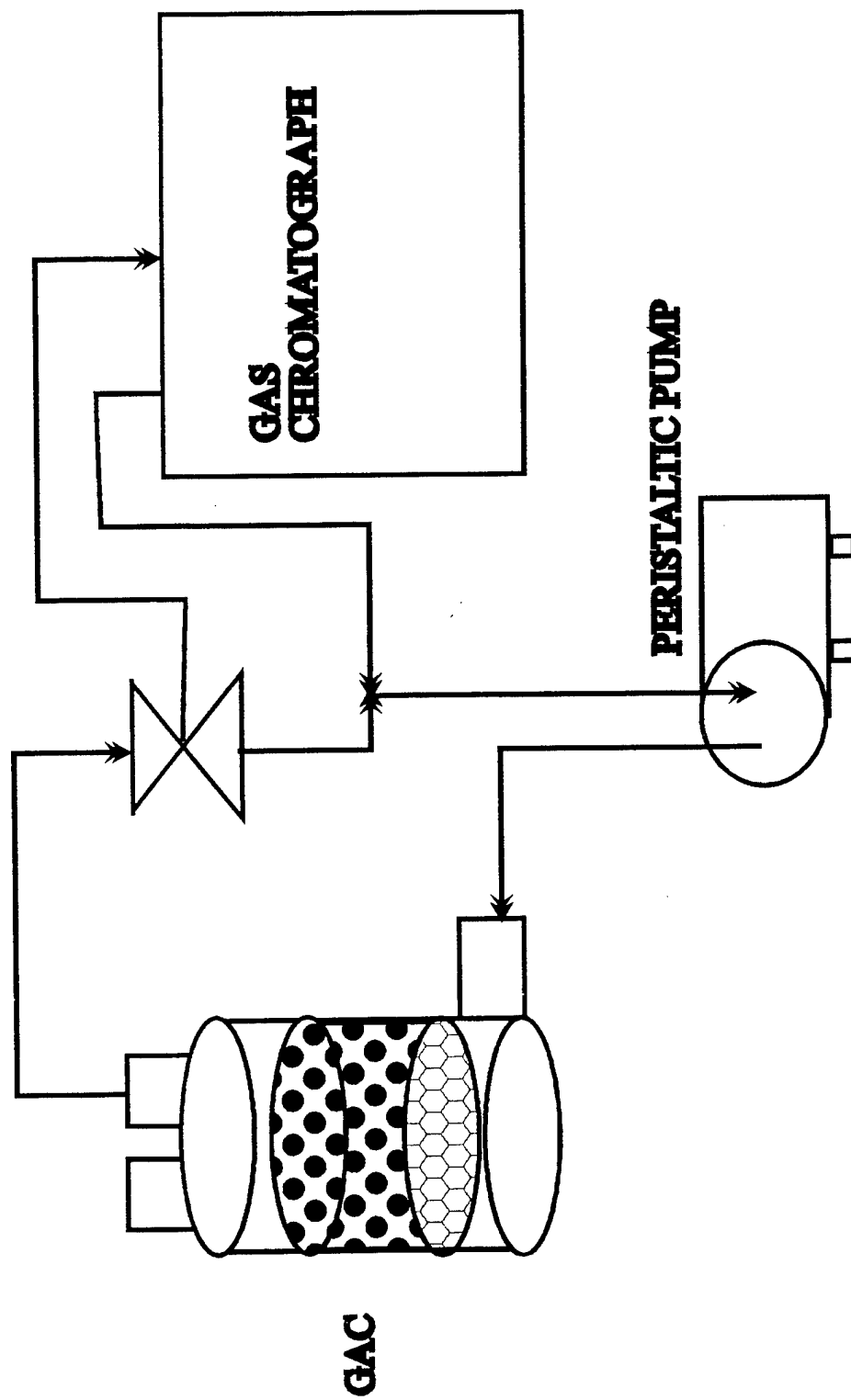

**FIGURE 3-2: FED-BATCH REACTOR CO₂ PRODUCTION
VERSUS TIME**

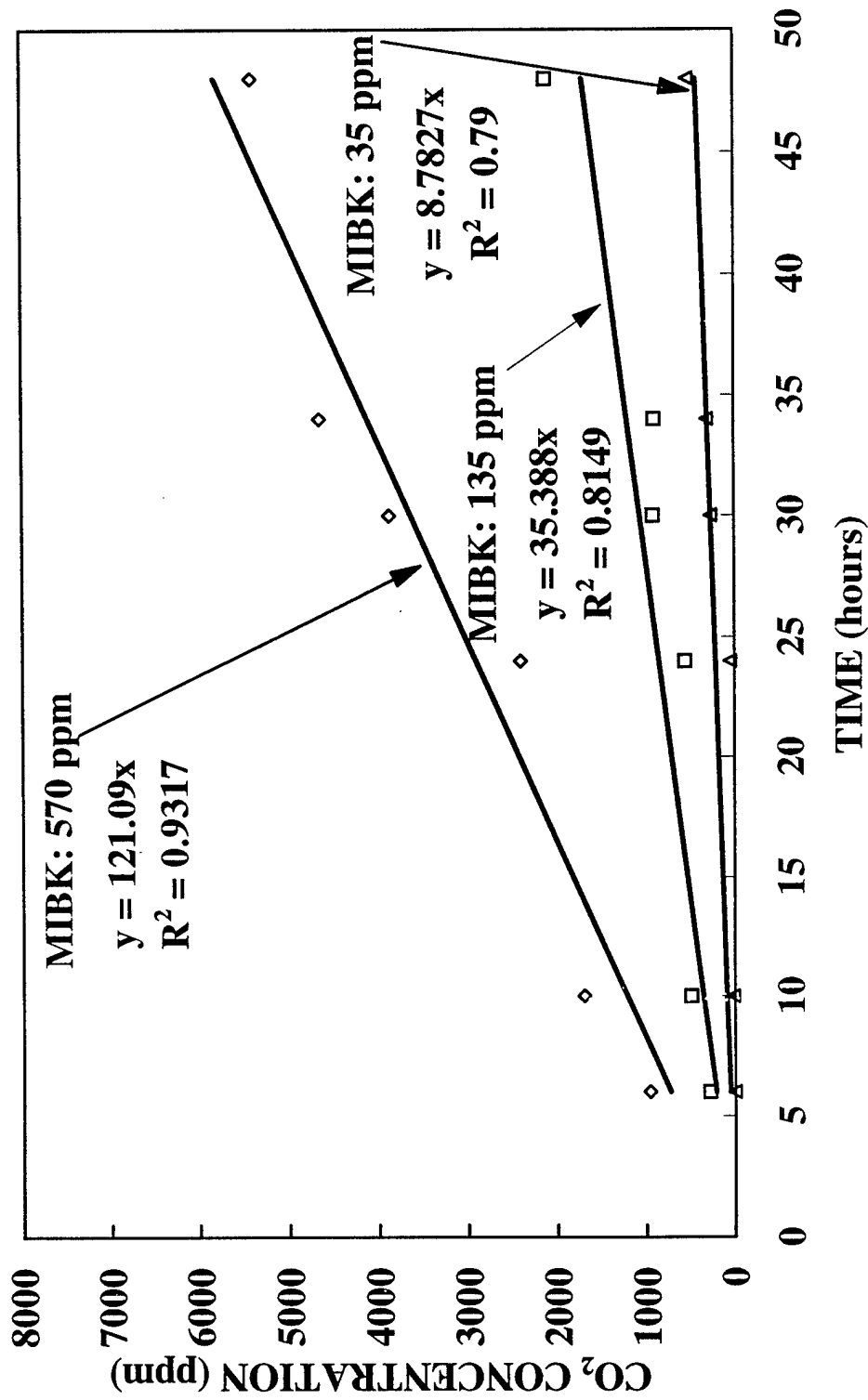

**FIGURE 3-3: FED-BATCH REACTOR CO₂ PRODUCTION
VERSUS TIME**

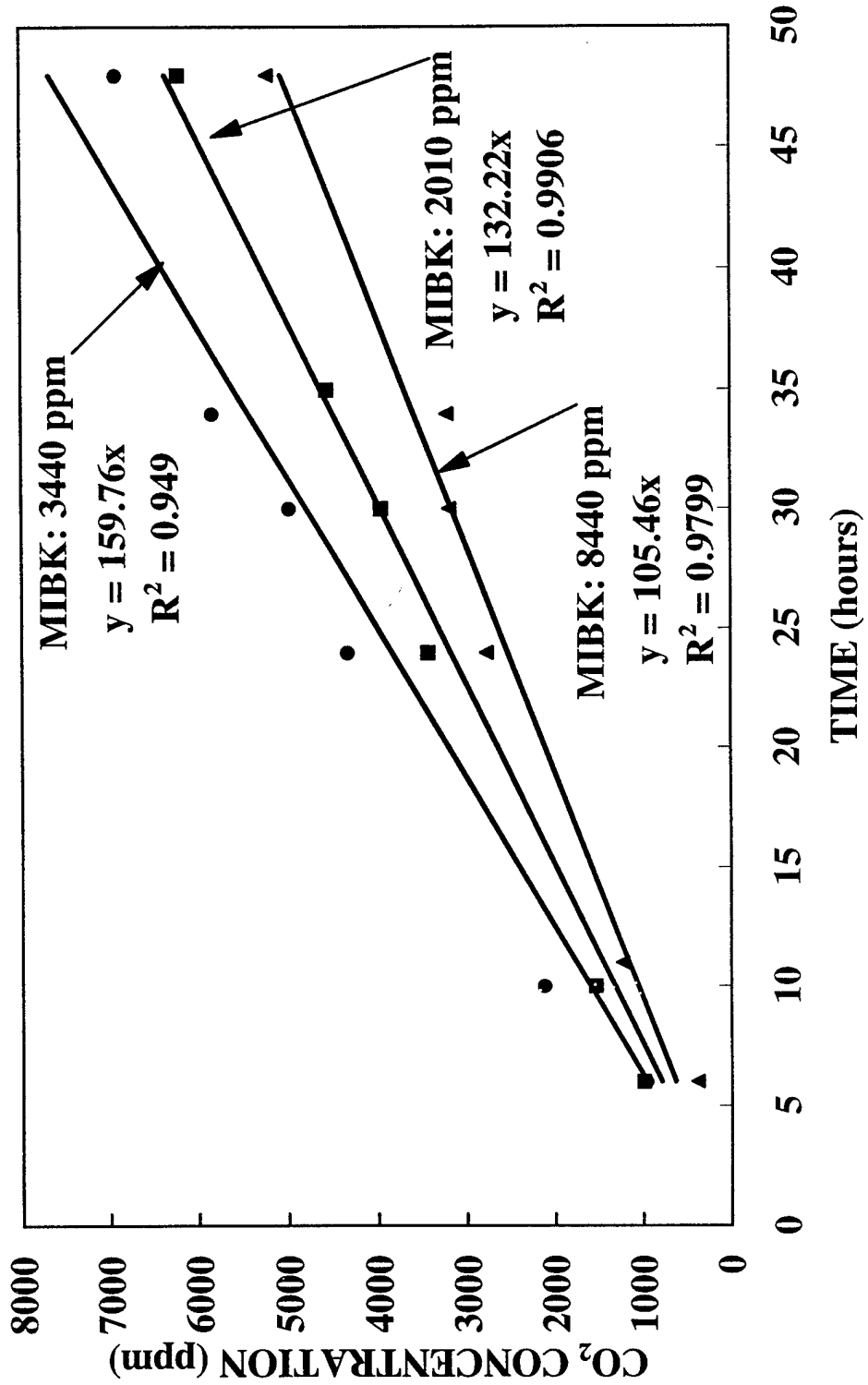

FIGURE 3-4 FED-BATCH REACTOR AIR-PHASE MIBK CONCENTRATION

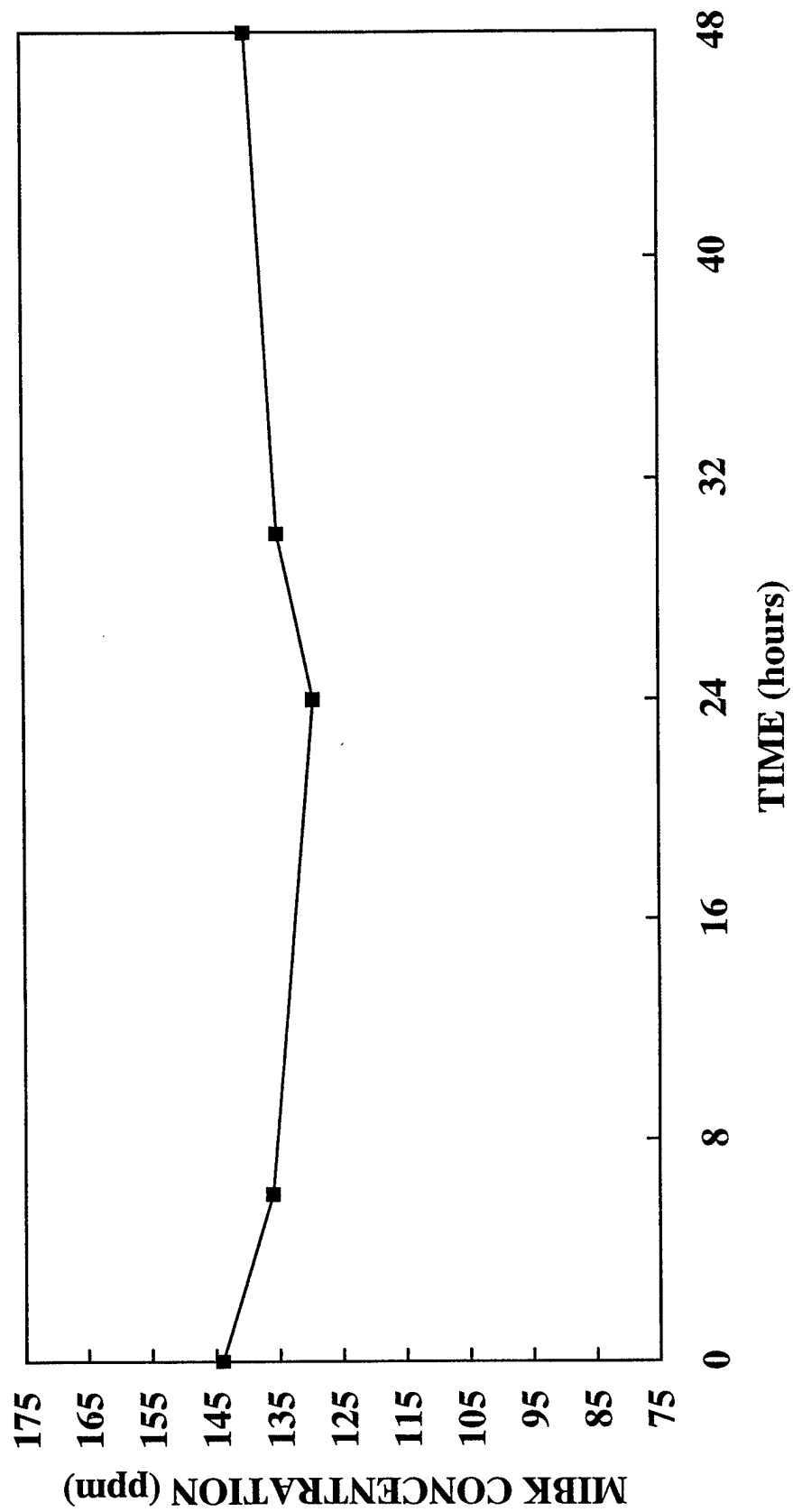

FIGURE 3-5: FED-BATCH REACTOR CO₂ GENERATION RATES

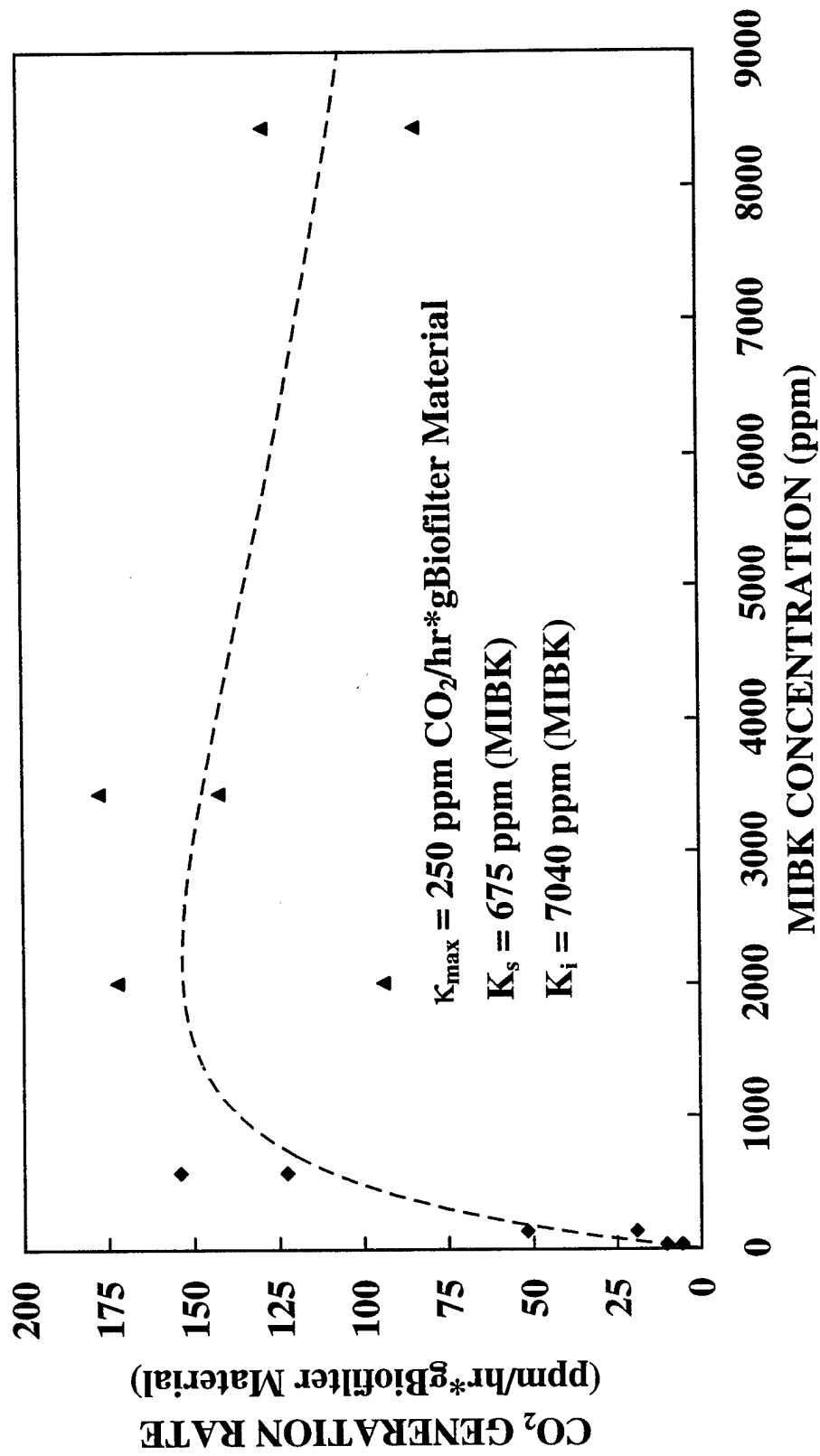

FIGURE 3-6: FED-BATCH REACTOR CO₂ FIRST ORDER GENERATION RATE

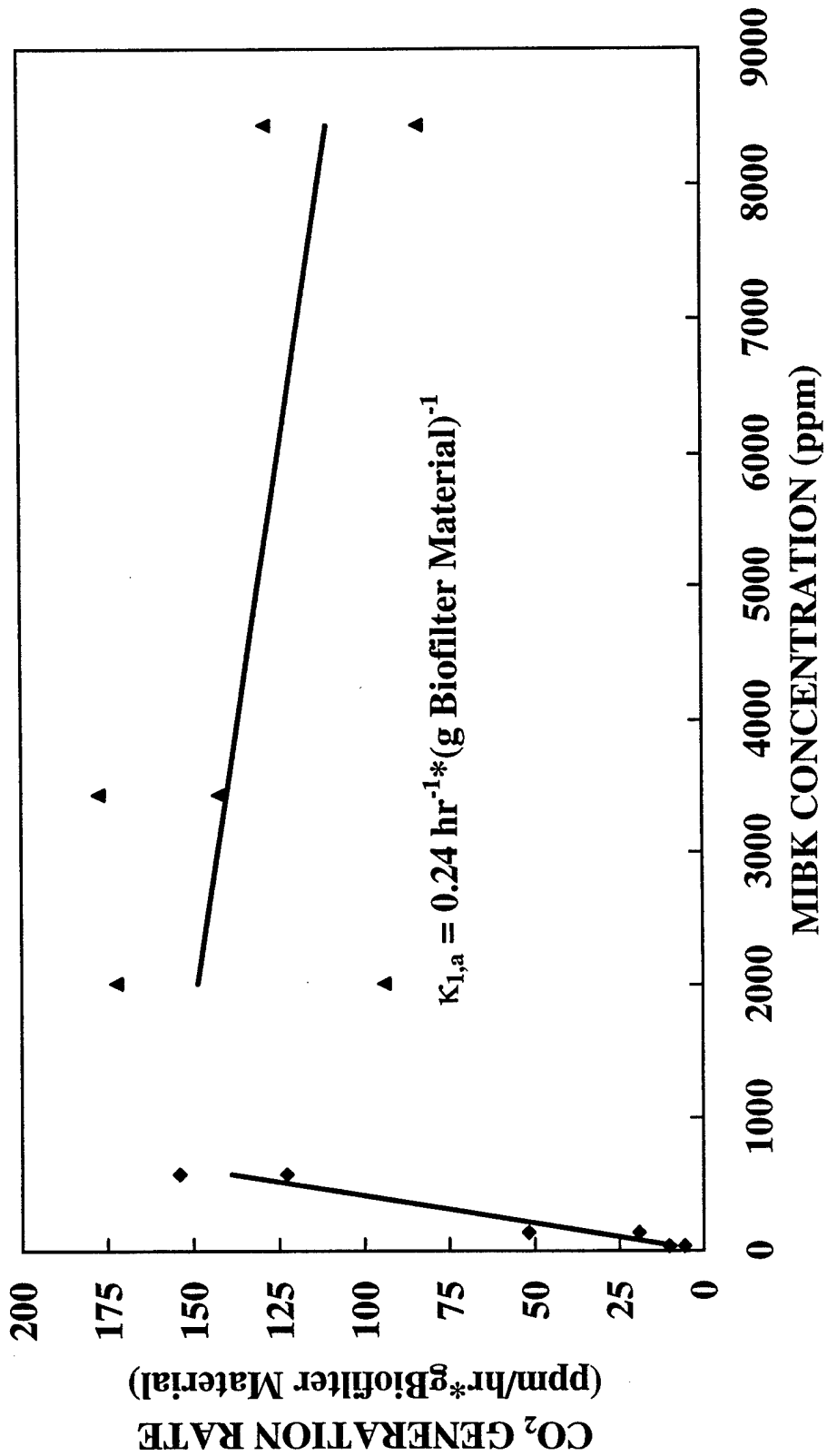
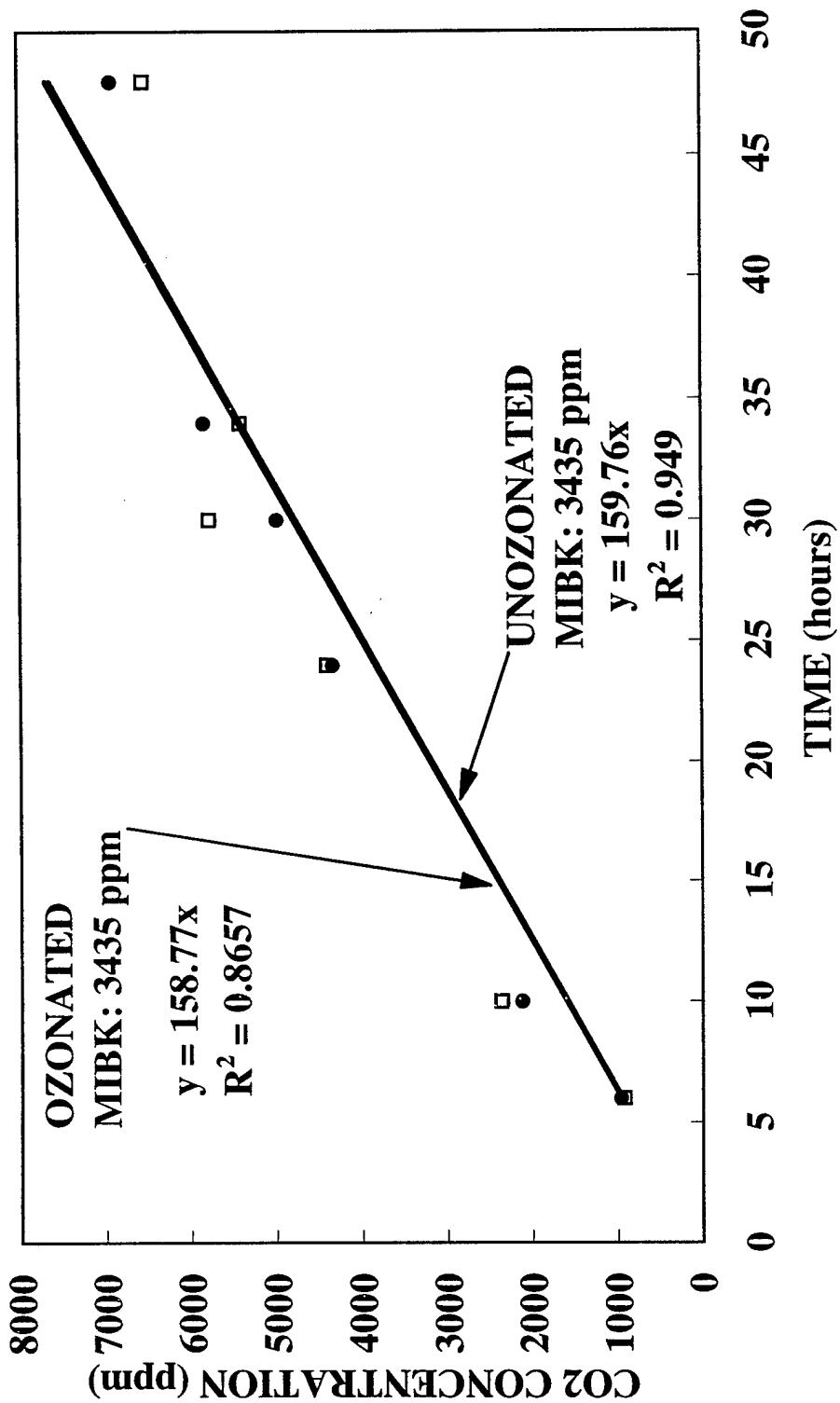

FIGURE 3-7: FED-BATCH REACTOR CO₂ PRODUCTION FOR OZONATED & UNOZONATED GAC BIOFILTER SAMPLES



CHAPTER 4
EFFECT OF ADVANCED OXIDANTS GENERATED VIA ULTRA-VIOLET
LIGHT ON A SEQUENTIALLY LOADED AND REGENERATED GRANULAR
ACTIVATED CARBON BIOFILTER

4.1 Abstract

The objective of this research was to investigate a sequentially loaded and regenerated GAC biofilter configuration, and then determine the effects of ozonation/advanced oxidation of the GAC biofilter during regeneration. In addition, an objective was to evaluate if the destruction and enhanced desorption of the VOCs from the GAC impacted biodegradation within the filter.

Sequentially loaded and regenerated bench-scale reactors have been constructed to operate in a manner analogous to a commercially available air pollution control system manufactured by Terr-Aqua Environmental Systems (TAES). The bench-scale systems consist of two GAC biofilter beds. One of the beds treated a simulated waste air stream while the second underwent regeneration. The beds were reversed and switched roles in a cyclic fashion. Three bench-scale systems have been used to compare the performance when run under different operating conditions. These different conditions are; (a) a humid air regeneration of a GAC biofilter system seeded with filamentous microorganisms from a TAES field site (*air-regen-seeded*), (b) a humid air regeneration of an unseeded GAC biofilter (*air-regen-non-seeded*), and (c) ozone/ associated oxidant (AO) regeneration of a seeded GAC biofilter (*AO-regen-seeded*).

For the AO-regen-seeded GAC biofilter, a maximum removal efficiency of >95% was achieved under nominal conditions consisting of a retention time of 148 seconds and an influent concentration of 125 ppm MIBK. On the other hand, the maximum removal rate obtained was $44 \text{ g/m}^3\cdot\text{hr}$ under nominal conditions consisting of a retention time of 11 seconds and a influent concentration of 115 ppm MIBK.

4.2 Introduction

Biofiltration is an application of commonly used biological treatment of pollutants to air pollution control [Bohn, 1992; Leson and Winer, 1991; Ottengraf, 1981; Hodge *et al.*, 1991, 1994; Shafeerdeen *et al.*, 1993; Utiker *et al.*, 1991]. Until recently, treatment of air pollution by biological means has received little notice. The method has now been accepted and employed with increasing frequency in Europe. This treatment process has emerged more slowly in the United States and is now just beginning to receive greater attention.

The research described herein focuses on the use of a system consisting of two biologically active granular activated carbon beds operated sequentially. One of the beds was used to treat an air stream laden with MIBK while the second was subject to either humid air (no pollutant) or ozone/AO regeneration. Every 24, hours the systems were switched so that the bed which had been loaded the previous 24 hours was then regenerated for the next 24 hours and vice-versa. These systems have been operated

continuously for over 14 months and they have shown continued removal of the pollutant from the waste air stream.

The objective of this research was to investigate the sequentially loaded and regenerated GAC biofilter configuration, and then determine the effects of ozonation/advanced oxidation of the GAC biofilter during regeneration. In addition, an objective has been to evaluate if the destruction and enhanced desorption of the VOCs from the GAC impacted biodegradation within the filter.

4.3 Literature Review

4.3.1 BIOLOGICAL AIR POLLUTION CONTROL PROCESSES

Biological treatment of waste air streams has customarily been divided into two broad categories, I) Bioscrubbers, and II) Biofiltration [Ottengraf, 1981; Leson and Winer, 1991; Overcamp *et al*, 1993]. In biofiltration the waste air passes through a solid porous media. This solid media serves as a matrix on which biological growth and subsequently biological oxidation of absorbed pollutants occurs. In bioscrubbers the waste air is contacted with a water stream and the pollutant migrates from the air to the water according to partitioning and the concentration gradient. The water loaded with the pollutant is then transferred to an oxidative reactor where the organics undergo biological treatment. These processes are often mass transfer limited and controlled by the solubility of the pollutant in question.

4.3.2 AIR BIOFILTERS

Biofiltration is the removal of air contaminants from off-gas streams in a solid phase reactor [Leson and Winer, 1991]. A biofilter typically consists of a filter bed of biologically active material. Numerous solid materials have been used as a support on which to immobilize the microbial community. If sufficient residence time is provided, the air pollutants will be sorbed by a wet biologically active layer at the surface of the solid filter material. Aerobic degradation will then occur in this biological layer. The filters in these systems must maintain a sufficient moisture content for optimal performance [Leson and Winer, 1991; Ottengraf, 1981; Prokop and Bohn, 1985]. At too high a water content the pores begin to fill and anaerobic zones develop, but at too low a water content microbial activity begins to decline and eventually stop. The required moisture content for optimal performance is a function of the filter material itself. For compost, moisture contents range from 20 to 40 percent dry weight basis, while for peat moss it is 40 to 60 percent, in soil it ranges from 10 to 25 percent, and for GAC moisture contents of 45 percent have been used [Prokop and Bohn, 1985; Hodge *et al*, 1995]. Moisture must often be added directly to the raw gas stream or sprayed on the filter material to maintain these operating conditions. Otherwise the filter material would dry out, thus removing the moisture which is essential for the survival and metabolism of the microorganisms as well as contributing to the filters buffer capacity [Leson and Winer, 1991]. The buffer capacity is critical in maintaining the filters pH. Commonly a pH of between 7 and 8 is preferred by bacteria present in the filters [Leson and Winer, 1991]. Fungi may also be present in biofilters and commonly prefer a pH on the acidic side of

neutrality, often in the range of pH 5-6.5 and may grow at a pH as low as 3 [Ingold and Hudson, 1993].

Soil is inherently an effective treatment media. Soil has a large adsorptive and catalytic surface area, ready access to oxygen, and a large population of microbial decomposers [Bohn and Bohn, 1986]. Soils are molecular sieves and retain virtually all chemical substances except inert, extremely volatile or water soluble compounds. While the compounds are sorbed in the soil the chemicals are hydrolyzed, oxidized, and their acidity or alkalinity neutralized. Soils also provide the nutrients necessary for microbial activity. Soil was the basis for the biofilters originally engineered in the United States and these biofilters were often described as a separate category know as "soil beds."

Compost or peat compost may be used in place of soil as the filter material in an engineered bed, and compost has generally been the basis of filter material used in recent application in Europe [Leson and Winer, 1991; Ottengraf, 1981]. Compost is superior to soil in the following respects; compost has a higher concentration of microorganisms and compost can be sieved, which promotes a more uniform distribution of the porosity in the filter bed and consequently a more uniform gas flow distribution and a lesser gas pressure drop [Ottengraf, 1981]. Compost-based filter material will typically provide sufficient inorganic nutrients for microorganisms and the addition of nutrients will not be required [Leson and Winer, 1991]. However, compost must generally be replaced every two to three years to preserve the structure of the filter. Soil beds and compost are generally constructed as open systems which are exposed to the effects of the environment.

A number of other materials have been used either as the primary filter material or as an additive to improve a given material's useful life. Materials such as porous clay or polystyrene spheres have been added to biofilters to increase the reactive surface area, durability, and to reduce back pressure [Leson and Winer, 1991].

Activated carbon has been used as a filter material to combine the added benefit of adsorption with biofiltration [Ottengraf, 1981; Hodge *et al*, 1991, 1994]. The adsorptive properties of the activated carbon promotes more even loading of the filter. Adsorption during periods of peak influent concentration lower the loading during these periods, while desorption during periods of low influent concentration help to maintain concentration levels.

Hodge *et al* [1991, 1994] have compared biodegradation rates ($\text{g Hydrocarbon /m}^3$ /hr) for various fuels that were loaded on filters consisting of soil, activated carbon, diatomaceous earth, compost, and diatomaceous earth/compost. These fuels include diesel fuel and JP-5, which is a military jet fuel. Diatomaceous earth was found to support the lowest biological degradation rates (for JP-5 $>0.5 \text{ g/m}^3/\text{hr}$); and it was generally the least effective filter support. Compost was found to support the highest biological degradation rate (for JP-5 $5.5 \text{ g/m}^3/\text{hr}$), while GAC was found to produce a rate (for JP-5 $4.5 \text{ g/m}^3/\text{hr}$) intermediate to the other two media. This provides further evidence that compost is the most hospitable environment for microbial growth and activity. However, GAC was found to have the best overall removal rate constant (83 per hour versus 22 per hour for compost) of any filter material in bench-scale continuous flow column studies. These bench-scale columns were 7.6 cm in diameter by 90.0 cm long

and exposed to the following range of mass loadings; 79 g VOC/m²*hr to 272 g VOC/m²8hr. Hodge *et al* [1991, 1994] proposed that there was a strong relationship between partition coefficients and removal rate. Thus, in the case of GAC versus compost, compost has a higher biological degradation rate but GAC has a higher partition coefficient (or adsorption capacity). Since GAC has a higher removal rate, Hodge *et al* [1991, 1994] proposed that the difference in partition coefficients is greater than that of biological degradation rates and this leads to the higher overall removal rates.

4.3.3 OZONE AND OXIDANT TREATMENT OF WATER PHASE BIOLOGICAL GAC

Although the author has not been able to find any literature investigating the effect of ozone in an air-phase biofilter, several researchers have looked at this effect in water treatment. The biodegradation rate (g TOC/ g GAC) in biological activated carbon beds used for removing organic compounds from water has been shown to increase when the water stream is ozonated prior to entering the filter bed [van Leeuwen *et al* 1985, Glaze *et al* 1986, Ventresque *et al.* 1990]. Glaze *et al.* [1986] propose that the ozonation of the water containing organics produces smaller compounds that were also more oxygenated and polar. These product compounds were shown to be less adsorbable on the activated carbon [Glaze *et al* 1986]. However, the overall removal of natural organic compounds that was achieved via biological activated carbon system was found to increase after the influent water had been preozonated. Ozonation was shown to increase the biodegradability of the organic compounds in water treatment operations [van Leeuwen *et al* 1985, Glaze *et al* 1986, Ventresque, *et al* 1990]. The higher oxygen levels in the water

created by ozonation were compared with higher oxygen levels created with pure oxygen. The increased oxygen levels were shown to have no impact on microbial growth or on biological degradation of the organics by the biologically activated carbon indicating that the systems were not oxygen limited [Ventresque *et al* 1990].

4.4 Materials and Methods

4.4.1 GAC BIOFILTER SYSTEM

Sequentially loaded and regenerated bench-scale reactors have been constructed to operate in a manner analogous to a commercially available air pollution control system manufactured by Terr-Aqua Environmental Systems (TAES) (Figure 4-1). The bench-scale systems consist of two GAC biofilter beds. One of the beds treated a simulated waste air stream while the second underwent regeneration. The beds were reversed and switched roles in a cyclic fashion. Three bench-scale systems have been used to compare the performance when run under different operating conditions. These different conditions are; (a) a humid air regeneration of a GAC biofilter system seeded with filamentous microorganisms that had been extracted from a TAES field site (*air-regen-seeded*), (b) a humid air regeneration of an unseeded GAC biofilter (*air-regen-unseeded*), and (c) ozone/ associated oxidant regeneration of a seeded GAC biofilter (*AO-regen-seeded*). The activated carbon used in all these reactors is a coconut based, 4 X 7 mesh, GAC produced by Barnebey-Sutcliffe (Columbus, OH). Coconut shell carbon is

commonly used in air pollution control and this particular brand had been used in actual field applications.

Each of the Penn State bench-scale systems consisted of a peristaltic pump with two separate pump heads, one which produced a flow of 3.8 mL/revolution and a second producing 0.8 mL/revolution (Cole-Parmer, Vernon Hills, IL). The air flow from the smaller pump head passed through a humidification chamber that consisted of a 1 L Erlenmeyer flask in which the air was bubbled through distilled water via a coarse glass frit. The humidified air stream then went directly to the GAC bed being regenerated for humid air regeneration. In the case of the O₃ associated radicals regeneration, the humid air stream passed through a 4" diameter by 18" long PVC column containing an ultra-violet lamp (Heraus-Amersil, NIQ 40/18, Duluth, GA) prior to entering the GAC biofilter bed. The air stream from the larger pump head was split into two streams. One of the streams was humidified in the manner previously described. The second air stream passed through a VOC generation chamber similar to the humidification chamber, except that it contained MIBK rather than distilled water.

These two air streams were then combined and fed into the GAC biofilter treating the gas stream laden with VOC. Each GAC biofilter consisted of two 1 1/2" diameter by 12" long PVC columns containing 6" of GAC that was supported on stainless steel flow straightener. One of the columns in each system was subjected to the humid air stream laden with a specific concentration of MIBK. The second bed was regenerated with either humid air or humid air which had passed through the UV reactor producing ozone and associated oxidants. This created an ozone concentration of 150 to 250 ppm in the

regenerant air stream at the influent face of the GAC bed. This also created a total advanced oxidant concentration of 6920 to 11540 ppm as O_3 , per the idometric method, as discussed in Chapter 2. These beds were run in a cyclic fashion with one bed treating the MIBK laden air stream for 24 hours while the second was regenerated. The effluent from the regenerating bed was fed back into the bed being loaded so the only emission from the system was from the bed being loaded.

The flow rate through the entire system was set at three different levels during this study, 1.12 L/min, 280 mL/min, and 70 mL/min. Since the effluent from the GAC biofilter being regenerated was fed back into the bed treating the waste air stream the empty bed contact times (EBCT) in the active biofilter bed were, 11 seconds, 37 seconds, and 148 seconds. The flow rates through the beds being regenerated were 195 mL/min, 49 mL/min, and 12 mL/min.

All air streams had been loaded with Methyl Isobutyl Ketone (MIBK) as the surrogate air pollutant, with concentrations which ranged from 35 to 150 ppm. The high and low flow rates were operated at one influent concentration, while the intermediate flow rate was operated at three different influent concentrations. This manner of operation provided experimental data that allowed a comparison of the effects of varying the influent concentration versus varying the influent flow rate. The concentrations were nominally: 125 ppm at 1.12 L/min, 150 ppm at 280 mL/min, 75 ppm at 280 mL/min, 35 ppm at 280 mL/min, and 135 ppm at 70 mL/min (see actual loadings as listed in the Results and Discussion section below). The influent flow rates and concentrations listed

above corresponded to the following mass loadings: 35 mg/hr, 10 mg/hr, 5 mg/hr, 2.5 mg/hr, and 2.3 mg/hr respectively.

The two GAC biofilter systems that had been seeded with filamentous microorganisms were dosed weekly with a mineral salts solution in order to maintain the moisture content of the biofilm on the GAC media. The mineral salts medium contained the following nutrients per liter of water: K_2HPO_4 , 1.0g; $CaCl_2 \cdot 2 H_2O$, 0.04g; $MgSO_4 \cdot 7 H_2O$ 0.1 g; $FeCl_2 \cdot 4 H_2O$, 0.007g; $(NH_4)_2SO_4$, 1.0g. The unseeded GAC biofilters were dosed at the same interval with a solution of 1 part bleach to 50 parts distilled water. The unseeded GAC biofilters received no dosing of mineral salts, and the bleach contained only traces of minerals.

The seeding of the biofilter was conducted by distributing 5 g of GAC from the TAES field system that was coated with filamentous microorganisms in virgin GAC, that had been soaked in the mineral salts solution for 48 hours, as the GAC was added to the PVC column. The seed GAC was acclimated to MIBK prior to its addition to the sequentially loaded and regenerated biofilters. This was accomplished by soaking the GAC from the field site in the mineral salts solution for 48 hours, then placing a 6" bed of GAC in a 4" PVC column. The column was then continuously exposed to a humidified air stream containing 44 ppm MIBK at a detention time of 22 seconds for several months which corresponded to a mass loading of 32 mg/hr.

4.4.2 DETERMINATION OF GAS PHASE CONCENTRATIONS OF MIBK

Sampling of the MIBK concentrations in the column influent and effluent air streams was conducted using a borosilicate sampler containing 3.72g of virgin Barnebey and Sutcliffe coconut shell GAC. The sampling tubes were attached to the influent or effluent flow tubing for 10 minutes. At the highest flow rate, this represented an EBCT of 0.5 seconds within the GAC sample tube. At the highest MIBK concentration (150 ppm), this amounted to a total mass loading of 1.84 mg MIBK/g GAC. Previous mass balances (Chapter 2) had indicated that more than 99% of the MIBK in an air stream will become adsorbed onto GAC under similar conditions.

The GAC was then transferred to a borosilicate sample vial with a teflon septa. The VOCs were extracted from the GAC using 37.2 mL of Carbon Disulfide (CS₂). The GAC was soaked in the CS₂ for approximately 24 hours.

Analysis of the VOC concentrations in the CS₂ was performed with a Hewlett-Packard 5890 Series II gas chromatograph (Valley Forge, PA) that was equipped with an flame ionization detector (FID). A 0.53 mm ID by 30 m long Supelcowax 10 column (Supelco Inc., Bellefonte, PA) was used with He as the carrier gas at a flow rate of 6 mL/min.

4.4.3 TOTAL ORGANIC CARBON, pH, and GC ANALYSIS OF GAC BIOFILTER

LIQUID

The runoff solution from the weekly addition of water solutions was analyzed to determine the pH of the reactors and if any soluble intermediates were being generated

during the biodegradation of the MIBK. The excess water solution was collected from the influent air stream port at the base of the GAC biofilter in a borosilicate glass vial. The pH was determined using an accumet model 10 pH meter (Fisher Scientific, Pittsburgh, PA).

The solution was then acidified to a pH of ~2 and the TOC of the raw sample and a sample filtered through a 0.2 μ m filter were determined using a Dohrmann Carbon Analyzer (Santa Clara, CA).

The solution was analyzed for soluble organic intermediates from the biodegradation MIBK by injecting a 1 μ L filtered sample of the raw runoff water into the GC. The GC was operated in the configuration described in Section 4.4.2.

4.4.4 RESPIROMETRY ANALYSIS

Oxygen uptake of biologically active GAC loaded with MIBK was monitored via a Challenge AER-200 Aerobic Respirometer (Challenge Environmental Systems, Inc., Fayetteville, AR). A glass reactor vessel was constructed which contained 20 grams of biologically active GAC that had been previously loaded with MIBK and was then placed in a closed loop with the respirometer. The GAC was supported on stainless steel flow straightener above 10 mL of distilled water. Air was continually recirculated through the reaction chamber by a peristaltic pump to ensure a constant MIBK concentration gradient. The recirculated air stream was passed through a KOH trap to remove the CO₂ that was generated by the biodegradation of the MIBK. The removal of CO₂ created a drop in the reaction chamber pressure. This drop in pressure was equalized via the addition of a

precise volume of O₂ that was pulled into the reactor through a cell which creates small bubbles (0.05 mg O₂/bubble) in a confined liquid. As each bubble passed through the cell it traveled past a sensor and was counted. The volume of O₂ added was summed over the experimental run, and this provided the total cumulative oxygen uptake by biological activity [Young *et al.* 1965].

4.5 Results and Discussion

4.5.1 PERFORMANCE OF BIOACTIVE SEED GAC

The 4" diameter continuous flow GAC biofilter used to prepare the bioactive GAC seed for the sequentially loaded and regenerated GAC biofilters was also used to determine operating parameters for the system. Figure 4-2 shows the performance of the continuous flow biofilter over the first 147 days of operation. During this time, this bed was loaded with 40 ppm MIBK (nominal) and it maintained a 22 second EBCT. In this figure the x-axis depicts the days of operation and the y-axis shows percent removal of MIBK defined as influent MIBK concentration minus effluent MIBK concentration divided by the influent concentration. The data points depict a three point moving average, the average of the day shown plus the two previous days. This format reduces the impact of outliers and gives a more representative line. The removal observed during days 1 to 20 was primarily the result of MIBK adsorption by the GAC independent of biological activity. This removal would be expected to follow a pattern shown by the predicted sterile (and dry) removal line in Figure 4-2 if the mass transfer zone in this used GAC had been as

abrupt as for the virgin GAC that had been previously tested [Dusenbury and Cannon, 1996]. This previous testing exhibited a mass transfer zone of 3 inches. A maximum adsorption capacity of 250 mg MIBK/ g GAC was used in calculating the predicted sterile removal line. This value was determined via a single bottle point maximum adsorption capacity experiment on the field GAC. The removal from day 21 to 50 was due at least in part to biological activity. This treatment efficiency was lost as the conditions in the reactor became unfavorable when the GAC dried out. Preliminary data indicated air that had been humidified by passing it through a water bubbler did not contain sufficient humidity and/or nutrients to maintain adequate levels of moisture and/or nutrients in the bed for proficient microbial activity. Under these conditions the GAC bed dried out and biological removal efficiency was reduced to a level below the limits of accuracy for the 4 inch continuous flow reactor system. However, even under these adverse conditions, biological activity was still detectable via respirometry experiments that measured oxygen uptake. Respirometry experiments during days 66 to 80 showed that GAC from the biofilter, which had dried out, and was loaded with MIBK consumed significantly more oxygen than virgin GAC which had been loaded under similar conditions (Figure 4-3).

After starting a pattern of adding distilled water supplemented with nutrients on a weekly basis, removal efficiency began to improve. Under influent conditions of 40 ppm MIBK with an EBCT of 22 seconds, removal efficiency progressively increased up to a value of 30%, as shown in Figure 4-2 days 100 to 147. At day 100, after seeing removal efficiency begin to recover due to nutrient water addition, seed material for the

sequentially loaded and regenerated reactors was removed from the continuous flow GAC biofilter.

4.5.2 GAC BIOFILTER REMOVAL EFFICIENCY AND RATE

The sequentially loaded and regenerated GAC biofilters treated influent air streams with methyl isobutyl ketone (MIBK) concentrations from 35 ppm to 150 ppm. The range 35 to 150 ppm represents concentrations commonly encountered in industrial applications that employ the Terr-Aqua system, according to the manufacturer of that system. The reactors were also operated at three different retention times to allow the author to evaluate the effect of flow rate, as well as influent concentration on the system. These flow rates corresponded to the following empty bed contact times, 11 seconds, 37 seconds, and 148 seconds.

After the influent concentration to the biofilter was set, the system was allowed to reach a pseudo-steady state condition. This condition was defined as occurring when both the influent and effluent concentrations had leveled out at a steady-state levels. Figure 4-4 shows the time (day of operation) on the x-axis and removal efficiency on the y-axis. The removal efficiency was calculated as one minus the effluent VOC concentration (ppm) divided by the influent concentration and was plotted as the 3-point moving average. Once the system had reached this pseudo steady state condition the various reactors were compared and the system removal rate was determined as the average removal rate of the plateau region (Table 4-1). A Fisher's protected least

significant difference (LSD) analysis was conducted for the pseudo-steady state region (listed in Table 4-1) for each condition and was shown on the respective plot.

Table 4-1 Sequentially Loaded and Regenerated GAC Biofilter Steady-State Performance

Reactor	Influent Conc. (ppm)	EBCT (sec)	Days @ Pseudo Steady-State	Mass Loading (mg/hr)	Effluent Conc. (ppm)	Removal Efficiency (percent)	Removal Rate (g/m ³ *hr)
Seeded	152	11	29-51	42	125	18	44
Ozonated	119	11	28-50	33	92	23	43
Unseeded	117	11	31-51	32	100	13	24
Seeded	146	37	97-163	10	80	45	26
Ozonated	137	37	98-164	9.4	82	41	22
Unseeded	163	37	97-163	11	92	44	28
Seeded	89	37	196-214	6.1	52	41	14
Ozonated	73	37	191-213	5.0	36	51	15
Unseeded	71	37	196-214	4.9	52	27	8
Seeded	40	37	235-277	2.8	22	44	7
Ozonated	33	37	232-274	2.3	15	55	7
Unseeded	45	37	235-277	3.1	31	33	6
Seeded	137	148	327-375	2.4	10	93	13
Ozonated	120	148	328-326	2.1	3	97	11
Unseeded	142	148	327-375	2.4	17	88	12

Figures 4-4 through 4-8 show the removal efficiencies for each operating condition for the three reactors. The information is summarized along with the GAC biofilter removal rate in Table 4-1. The intrinsic microbial kinetics and a model to the overall biofilter removal efficiency have been discussed separately (Chapter 3 and 5). The substrate (MIBK) was found to be inhibitory to biological degradation at concentrations greater than 3010 ppm. The biofilm kinetics were found to be well represented by the Haldane-Andrews type kinetic model. However, as the concentrations of interest are all well below the inhibitory concentration the biofilm kinetics may be considered to follow 1st or transition order kinetics.

The detention time within the GAC biofilter has a more significant effect on the efficiency of the biofilter to remove contaminants from the waste air stream than the contaminant concentration. A four fold increase in detention time, from 11 seconds to 44 seconds, led to a doubling of the removal efficiency, 18% to 45% for the *air-regen-seeded* and 23% to 41% for the *AO-regen-seeded* (see figures 4-4 to 4-8). However, a three and a half fold decrease in influent concentration, from 140 ppm to 40 ppm, led to little change in the GAC biofilter removal efficiency, 45% to 44% for the *air-regen-seeded* and 41% to 51% for the *AO-regen-seeded* biofilter. These results were in agreement with first-order or transition biofilm kinetics as predicted by the calculated biological degradation parameters. If the biofilm was modeled over the entire range of conditions investigated as Haldane-Andrews type kinetics the best fit parameters were; $k_{\max} = 25 \text{ ppm MIBK/HR} \cdot \text{g Biofilter Material}$, $K_s = 675 \text{ ppm MIBK}$, and $K_i = 7040 \text{ ppm}$

MIBK (see Chapters 3 and 5). Where k_{\max} represents an apparent maximum rate. Based on these kinetic parameter estimates the concentrations of interest fall in the scope of first order or possibly transition kinetics. If the data of interest was modeled as first order up to 570 ppm the first order rate constant was 0.24 hr^{-1} . Under these conditions a decrease in concentration leads to a decrease in the rate of degradation, reducing the impact of the lower mass loading. However, a reduction in flow rate does not change the degradation rate but does increase the time available for degradation (the empty bed contact time). Therefore, the substrate was degraded at the same rate for a longer time leading to an overall greater mass of substrate being degraded and hence a greater removal efficiency $(1 - \text{concentration applied} / \text{concentration removed}) * 100$.

Both the *air-regen-seeded* and *AO-regen-seeded* GAC biofilters have been more stable and adjusted to fluctuations in the influent concentration more quickly than the *air-regen-unseeded* GAC biofilter as shown in Figures 4-4 through 4-8. The two seeded reactors have also continually produced a higher removal rate than the unseeded reactor. The *air-regen-unseeded* reactor has not received the nutrient additions that the seeded reactors have and has not developed the filamentous organisms present in the two seeded reactors, per visual inspection. In contrast to the difference between the seeded and unseeded reactors the *AO-regen-seeded* reactor and the *air-regen-seeded* reactor have reacted in a similar manner to changes in influent concentration. However, the *AO-regen-seeded* biofilter has generally maintained a higher removal efficiency than the *air-regen-seeded* biofilter. The *AO-regen-seeded* reactor appears to achieve a higher percent removal at 35, 75, 115, and 135 ppm. Due to system constraints the *AO-regen-seeded*

reactor also had a consistently lower actual influent concentration, with the concentration used to define the systems being the nominal concentration for all systems. The rotometers and glass frits used did not produce the equivalent concentration at equivalent settings and were therefore adjusted to create the closest stable concentrations with each reactor. While the *AO-regen-seeded* biofilter had a higher removal efficiency than the *air-regen-seeded* under most conditions the removal rates were roughly equal under all conditions indicating that the *AO-regen-seeded* system was able to degrade an equivalent mass of MIBK at a lower influent MIBK concentration. This suggests that at equivalent influent concentrations the ozonated reactor would be able to degrade more VOC than the *air-regen-seeded* biofilter, supporting the trend revealed by the removal efficiency indicating the AO regeneration is more effective than air (see further discussion Chapter 5).

4.5.3 OZONE PENETRATION

The authors have shown the majority of the ozone applied to the influent face of a GAC bed is consumed in the first 1/4-inch and for all practical purposes is completely removed by 3-inches [Dusenbury and Cannon, 1996; Cannon *et al*, 1996]. The presence of MIBK was found to enhance the ability of the ozone into the GAC bed but the majority of the ozone was still consumed by the GAC bed. After 24 hours of regeneration with ozone in a sterile GAC bed the majority of the MIBK remained as MIBK. Approximately 10% of the MIBK was degraded to other compounds, but the majority of these compounds were more oxygenated organics that still contained 4 to 6 carbon atoms.

Ozone and advanced oxidants in the influent to a loaded GAC bed was found to enhance desorption of the VOC especially in the first 3 inches. This enhanced desorption would create a higher effective MIBK concentration in the air-phase of a GAC biofilter receiving ozone regeneration. The small degradation in MIBK and/or the enhanced desorption appears to enhance the biodegradation rate of a GAC biofilter.

The effects of ozonation may have been improved in the GAC biofilter.

Experiments indicated that ozone was able to penetrate a GAC bed saturated with water to a greater extent than a dry GAC bed (Figure 4-9). When ozone was applied to a GAC bed that had become saturated with water, and then drained, 60% of the ozone was able to penetrate 1/4-inch into the GAC bed, and even at three inches, 15% of the initial ozone was present. The ability of the GAC to scrub the ozone from the air-stream may have been kinetically hindered by mass transfer through water. The ozone/AO would have to be absorbed by the water and transported to the GAC interface before it would be able to react with the GAC. Under the saturated conditions within the GAC biofilter the ozone and advanced oxidants may have been able to react to a greater extent with the VOCs present thus increasing the impact of enhanced desorption and biological degradation of smaller more oxygenated compounds which may be more easily degraded.

4.5.4 EFFLUENT CONCENTRATION FROM BED UNDERGOING LOADING OVER 24 HOURS

The effluent MIBK from the GAC biofilter that was treating the air laden with contaminant was studied over a 24 hour time period. There was the potential for the

desorption of MIBK during the 24 hour regeneration of the a GAC biofilter to reduce the air phase concentration of MIBK. Earlier studies have shown that ozonation of a loaded GAC bed enhanced the desorption of VOC from the bed [Dusenbury and Cannon, 1996; Cannon *et al*, 1996]. Therefore, we wanted to test whether the *AO-regen-seeded* biofilter had a lower effluent concentration immediately following regeneration. The time frame for this testing began as soon as the reactor was switched from regeneration to loading and continued until the reactor was switched back to regeneration. During this time, the “influent” to the GAC beds was comprised of the exhaust gases from the second GAC bed that was undergoing regeneration, plus the “contaminant” waste stream containing MIBK that had vaporized through the bubbling apparatus.

The purpose of this test was two fold, first to determine whether ozonation enhanced the regeneration. The second was to determine if the concentration within the biofilters was essentially constant for kinetic and modeling purposes.

The effluent concentration of both the *AO-regen-seeded* and *air-regen-seeded* reactors was found to be only slightly depressed if at all (by 0 - 15%) during the first hour, and then was essentially constant over the balance this 24 hour period (Figure 4-10). This shows that the mass of MIBK that was removed due to regeneration was not large enough to reduce the equilibrium air-phase concentration. This shows that the reactors have reached a pseudo-state condition where the air phase MIBK concentration was essentially constant during all phases of operation.

4.5.5 BIOFILTER LIQUID pH AND TOTAL ORGANIC CARBON CONCENTRATION

The pH and total organic carbon (TOC) of the runoff from the nutrient or chlorinated water addition to the GAC biofilters was analyzed to determine differences between the systems and to determine the amount of removal that was actually accounted for by the liquid runoff. Less than 1% of the MIBK removal may be attributed to leaching of aqueous-phase VOCs during water runoff in all three reactors. The *air-regen-unseeded* reactor had the largest TOC in the runoff, 762 ppm as C versus 219 ppm for the *AO-regen-seeded* and 198 ppm for the *air-regen-seeded*. The pH of the *AO-regen-seeded* GAC biofilter (3.6) was significantly lower than both the *air-regen-seeded* GAC biofilter (6.9) and the *air-regen-unseeded* biofilter (7.0) (Figure 4-11). This could suggest that the ozone was influencing the oxygenation functionality and creating carboxyl or similar groups on either the skeletal GAC, adsorbed VOCs, or both [Dietz and Bitner, 1972, 1973; Takeuchi and Itoh, 1993; Dusenbury and Cannon, 1996; Cannon *et al*, 1996]. However, even at this low pH the *AO-regen-seeded* reactor was able to produce better removal rates to the *air-regen-seeded* reactor indicating that the microorganisms present were able to tolerate low pH conditions and still maintain their effectiveness. This suggests that a significant population of fungi which are more pH tolerant and prefer a lower pH (~5) than bacteria (~7) was involved in the biodegradation of VOCs within the biofilters. The low pH of the *AO-regen-seeded* reactor was not accompanied by an increase in the TOC. The GC analysis of the *AO-regen-seeded* runoff also did not show any new peaks. During these analysis we did not detect any soluble organic acids that were produced as a result of the ozonation of the MIBK laden GAC

biofilter. Thus, the reduced pH was likely a result of oxidation of the GAC or inorganic acids produced during Ultra-violet light generation of ozone, and it was not due to partial oxidation of the adsorbed VOCs.

4.5.6 BIOFILTER RESPONSE TO CHANGES IN INFLUENT CONCENTRATION

During this study there were several opportunities to study the response of the sequentially loaded and regenerated GAC biofilters to changes in the influent concentrations of the system. After reductions in the influent concentrations, the GAC biofilter produced a temporary condition where there was a larger effluent MIBK concentration than influent concentration. With time, effluent concentration dropped until the new pseudo steady-states removal efficiency was achieved (Figures 4-4 to 4-8).

The phenomena where the MIBK effluent concentration is higher than the influent concentration may be explained by the GAC's equilibrium isotherm. While this isotherm is rather flat (Figure 4-12) there is still a slight decrease in the GAC's capacity for MIBK with decreasing influent concentration. Therefore, as the influent concentration was reduced, MIBK was desorbed from the GAC to achieve an equilibrium state with this new concentration. This desorption was found to take roughly one week to reach completion. In the case of an increase in the influent concentration the reverse phenomena occurred (Figures 4-5 to 4-7). Whereby removal was enhanced by adsorption as the GAC reached a higher loading due to the new equilibrium conditions. Under varying influent loading conditions this equilibrium adjustment would dampen the changes of substrate concentration to the microorganisms. During periods of high

loading, the GAC would adsorb the excess VOC that the microorganisms could not degrade, and during periods of zero loading the VOC would slowly be desorbed and provide substrate to the microorganisms.

The two seeded reactors, *AO-regen-seeded* and *air-regen-seeded* reached the new steady state removal more quickly than the *air-regen-unseeded* biofilter with no nutrient addition. This may be explained by the impact of the biological activity on the GAC biofilter. As MIBK desorbed from the GAC it was more rapidly degraded by the microorganisms in the two seeded biofilters. The more rapid degradation would cause a higher flux into the biofilm and therefore, a lower air phase concentration. This would lead to a more rapid desorption from the GAC since the equilibrium driving force would be greater.

4.6 Summary and Conclusions

In summary, a sequentially loaded and regenerated GAC biofilter that was seeded with microorganisms from a field system was investigated under ozonated and non-ozonated conditions and compared with an unseeded system. Results revealed that the two seeded systems were more stable and generally performed better, performance is defined by MIBK removal efficiency and removal rate, than the unseeded system, where the *AO-regen-seeded* and *air-regen-seeded* systems performed in a similar manner. A maximum removal efficiency of >95% was achieved under nominal conditions consisting of a retention time of 148 seconds and a influent concentration of 135 ppm MIBK. On

the other hand, the maximum removal rate obtained was $44 \text{ g/m}^3\cdot\text{hr}$ under nominal conditions consisting of a retention time of 11 seconds and an influent concentration of 115 ppm MIBK.

The unique operation of this system had a GAC biofilter alternatingly exposed to a simulated waste air stream laden with MIBK for 24 hours, followed by exposure to a regeneration air stream for 24 hours. This set up the potential for the effluent concentration to vary with time during the regeneration phase. However, the effluent concentration was found to be essentially constant with time from the *air-regen-seeded* biofilters producing a pseudo-steady state air phase concentration within the biofilter at all times. The *AO-regen-seeded* biofilter was found to behave in a manner similar to the *air-regen-seeded*, even though earlier studies by the authors [Dusenbury and Cannon, 1996 a,b] had found ozonation of a GAC bed to enhance desorption of VOCs. Reductions in influent mass loading was found to cause desorption of MIBK from the GAC in the biofilters. This resulted in more MIBK in the effluent than the influent for approximately one week.

The pH of the liquid runoff was also investigated and found to be significantly lower in the *AO-regen-seeded* biofilter (pH 3.6) than either of the unozonated reactors (pH ~7). The low pH appeared to have no effect on overall system performance, with the *AO-regen-seeded* biofilter performing better than the *air-regen-unseeded* biofilter, as well as, the seeded *air-regen-seeded* reactor. The GC analysis also showed no new soluble organic compounds, these suggest that the acidity is from an inorganic or immobilized source.

FIGURE 4-1: SEQUENTIALLY LOADED & REGENERATED GAC BIOFILTER

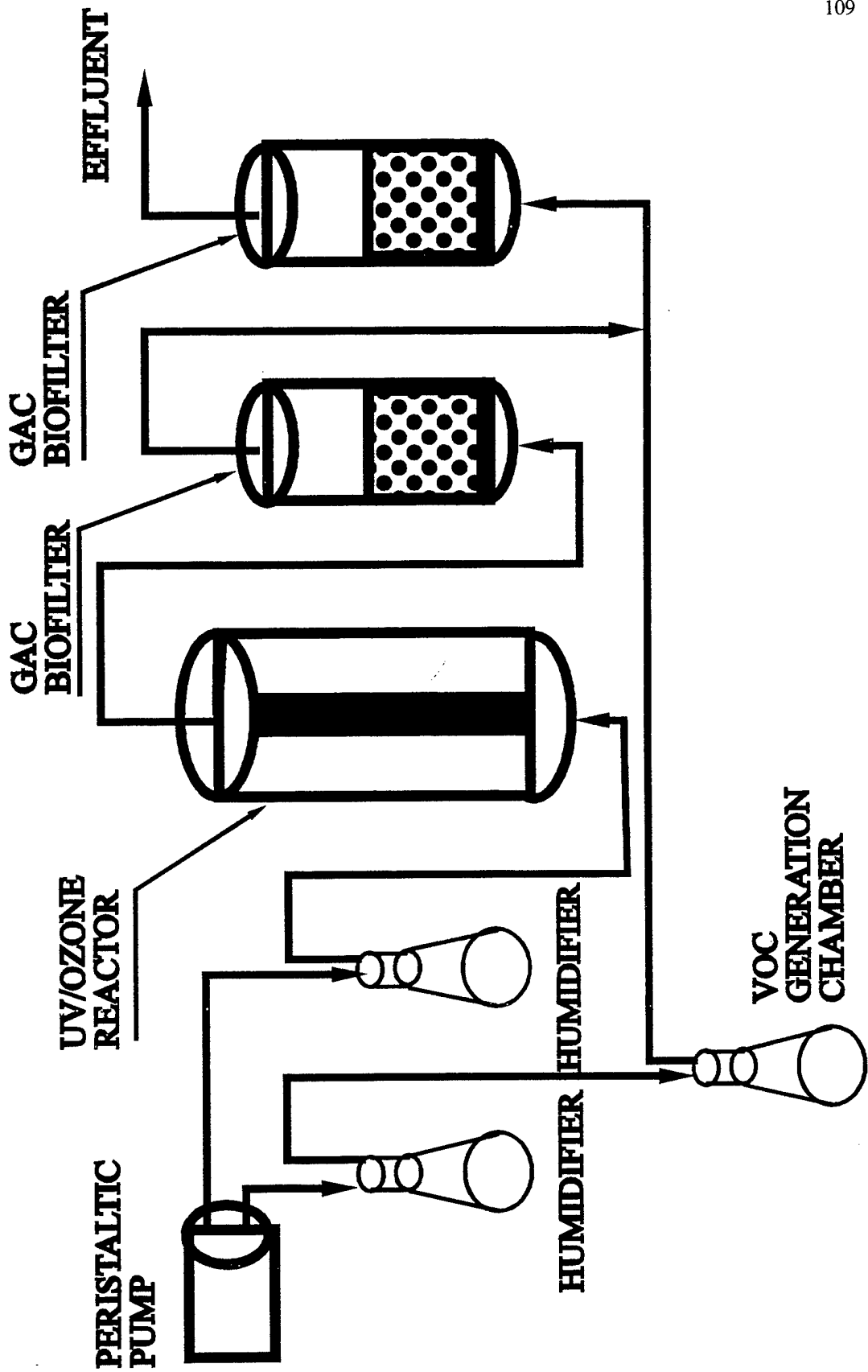

FIGURE 4-2: CONTINUOUS FLOW BIOFILTER REMOVAL EFFICIENCY AT 40 PPM MIBK, 22 SECOND EBCT

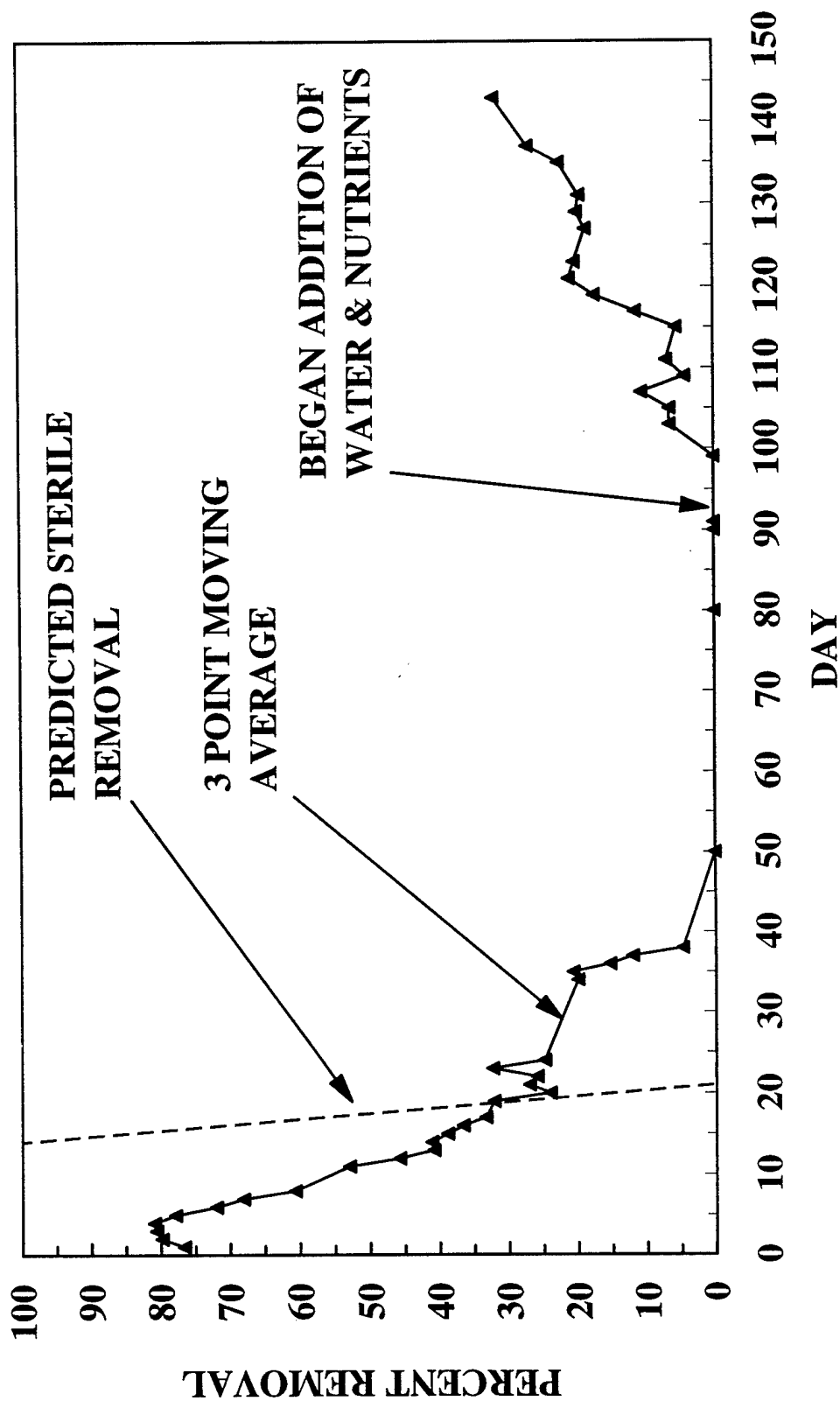

FIGURE 4-3: OXYGEN UPTAKE FOR 20 GRAMS GAC FROM CONTINUOUS FLOW BIOFILTER LOADED AT 175 PPM MIBK

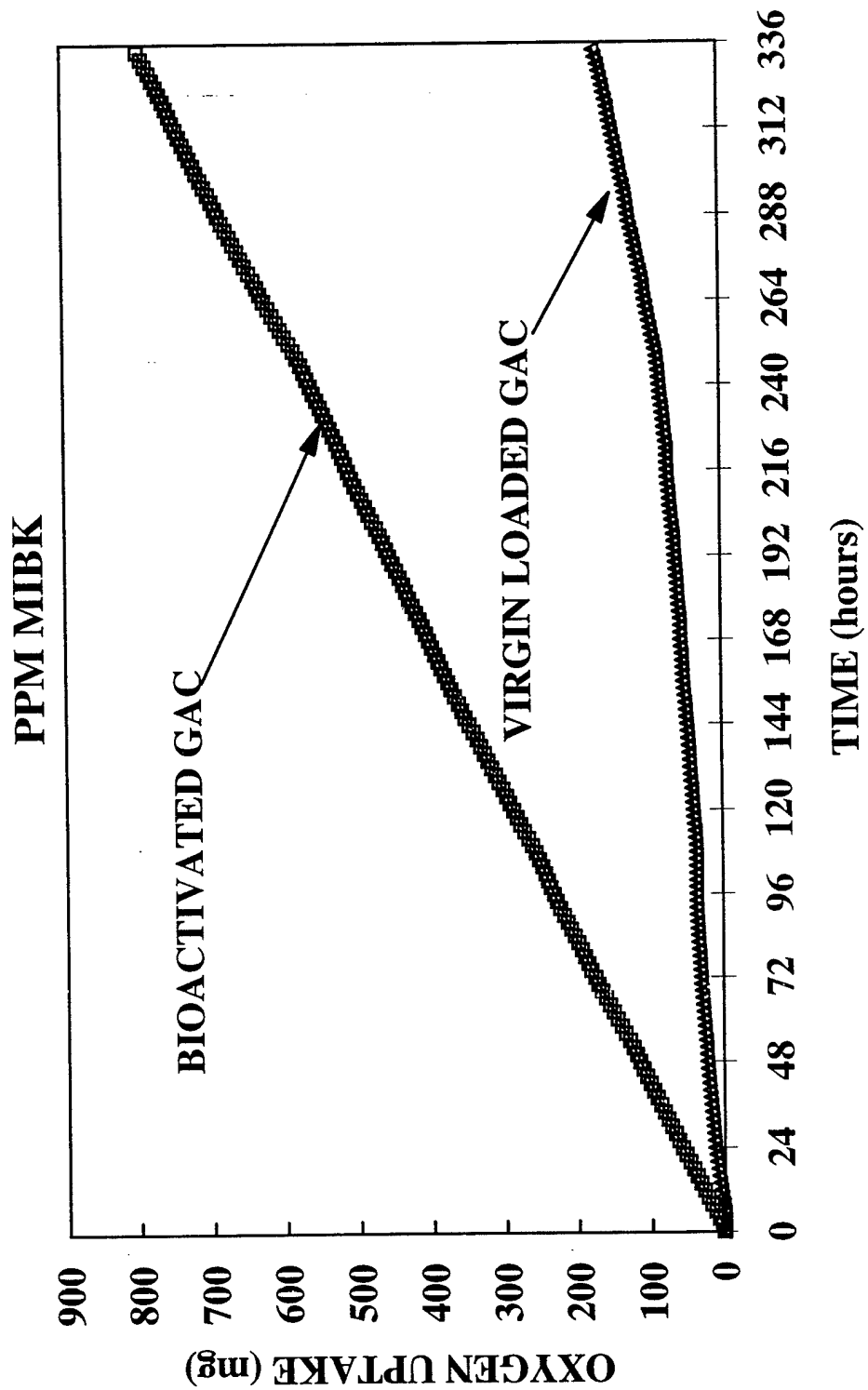

FIGURE 4-4: SEQUENTIAL REACTOR REMOVAL EFFICIENCY AT 115 PPM MIBK, 11 SECOND EBCT

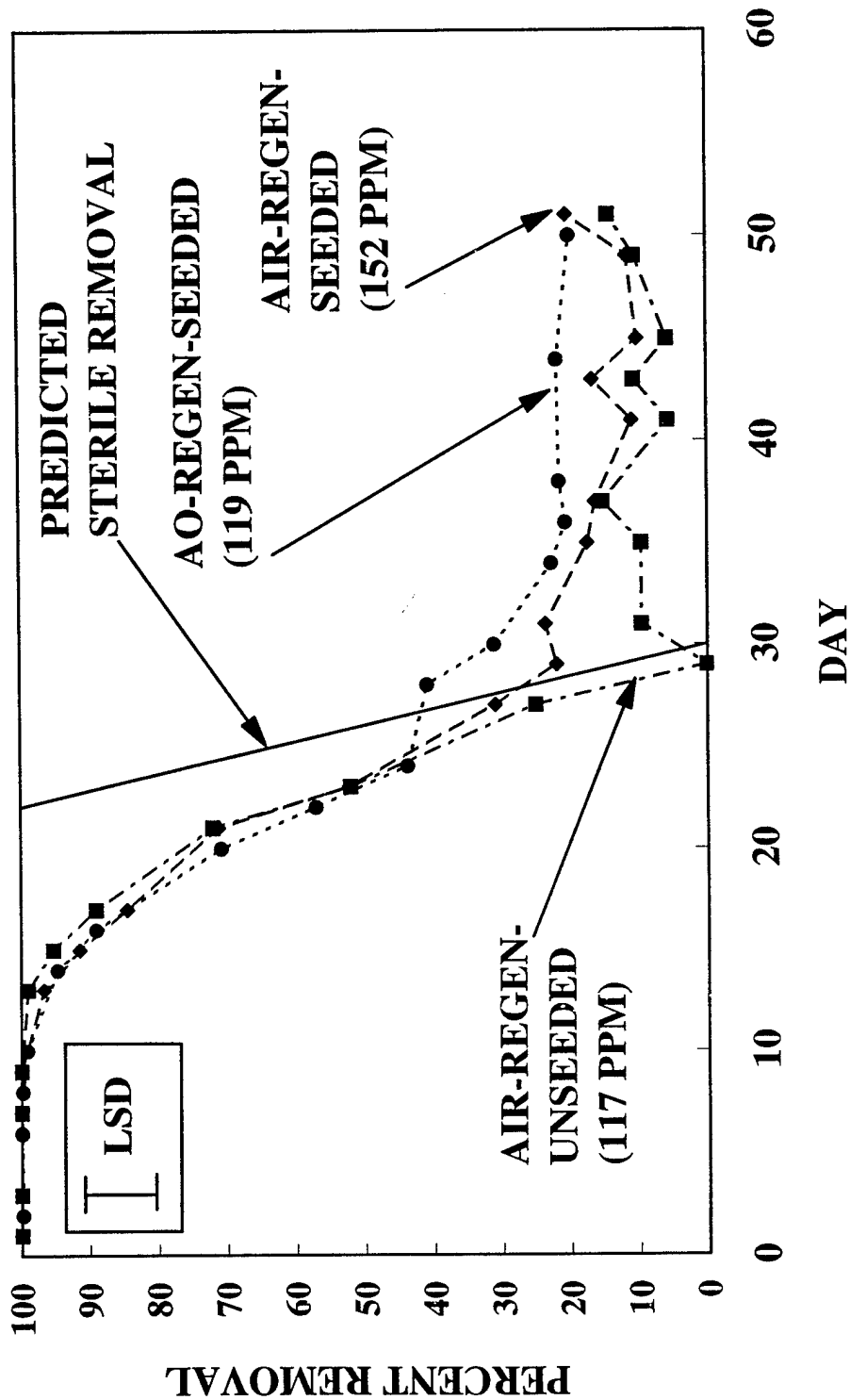

FIGURE 4-5: SEQUENTIAL REACTOR REMOVAL EFFICIENCY AT 140 PPM MIBK, 44 SECOND EBCT

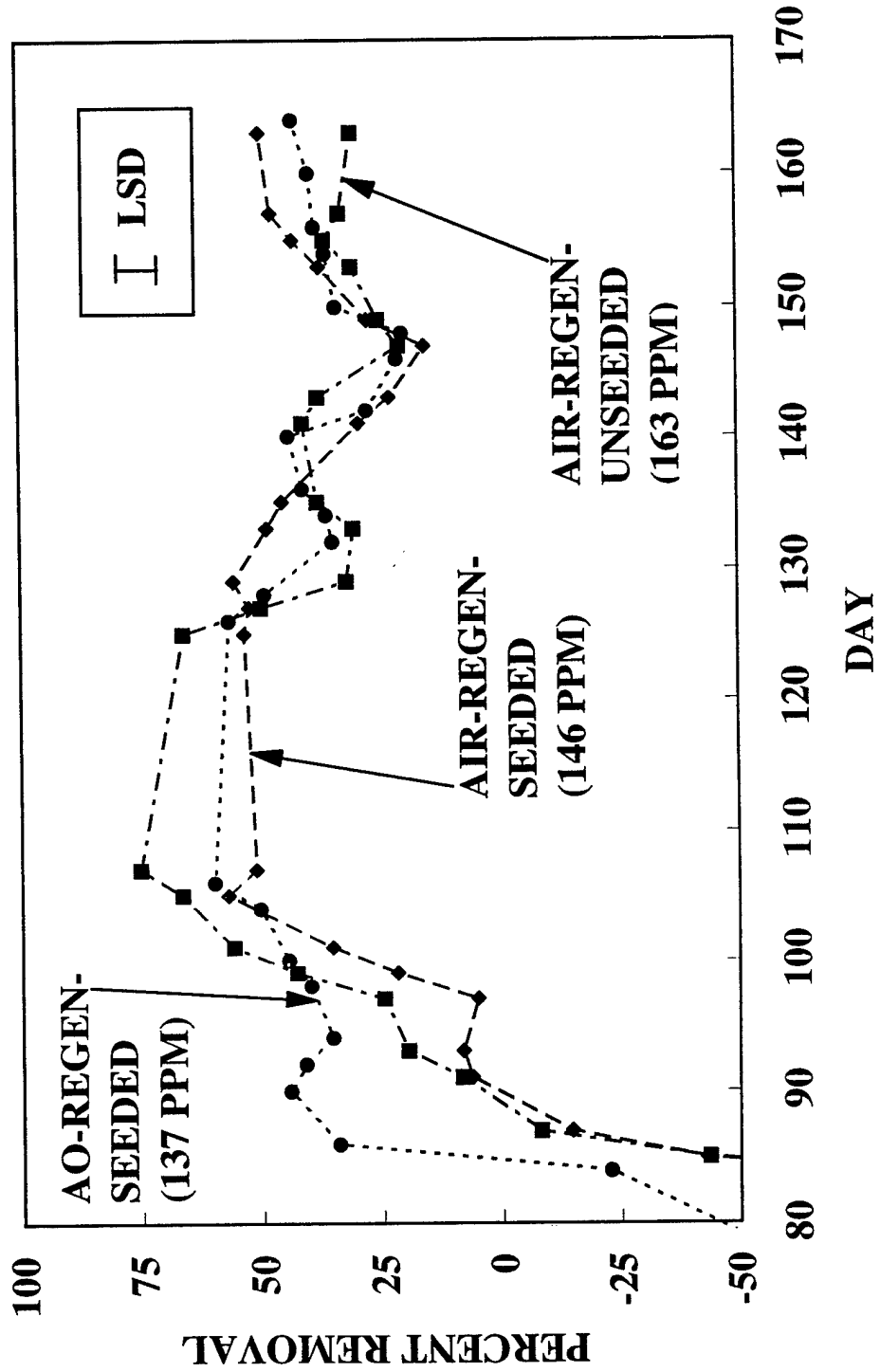

FIGURE 4-6: SEQUENTIAL REACTOR REMOVAL EFFICIENCY AT 75 PPM MIBK, 44 SECOND EBCT

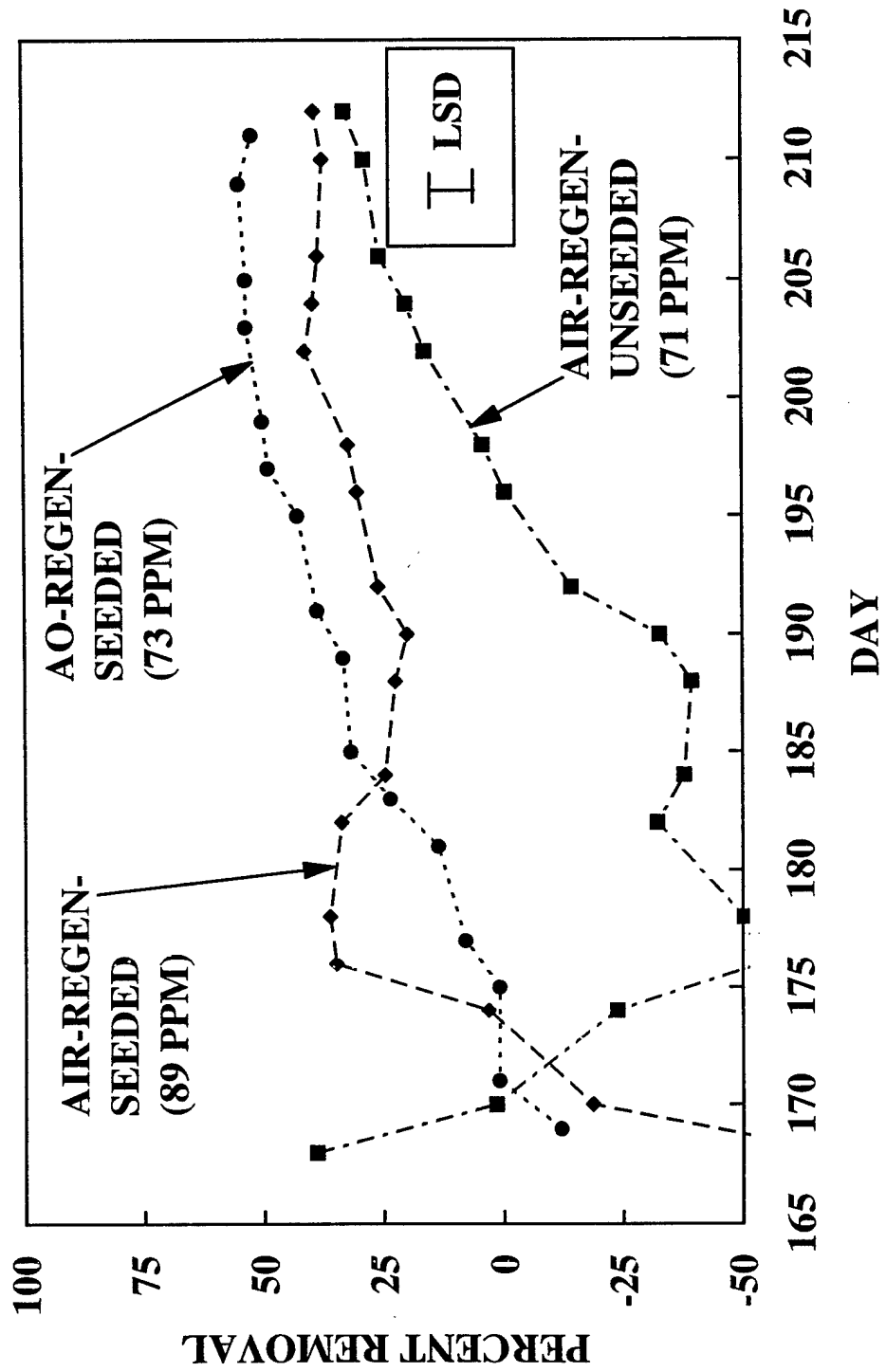

FIGURE 4-7: SEQUENTIAL REACTOR REMOVAL EFFICIENCY AT 35 PPM MIBK, 44 SECOND EBCT

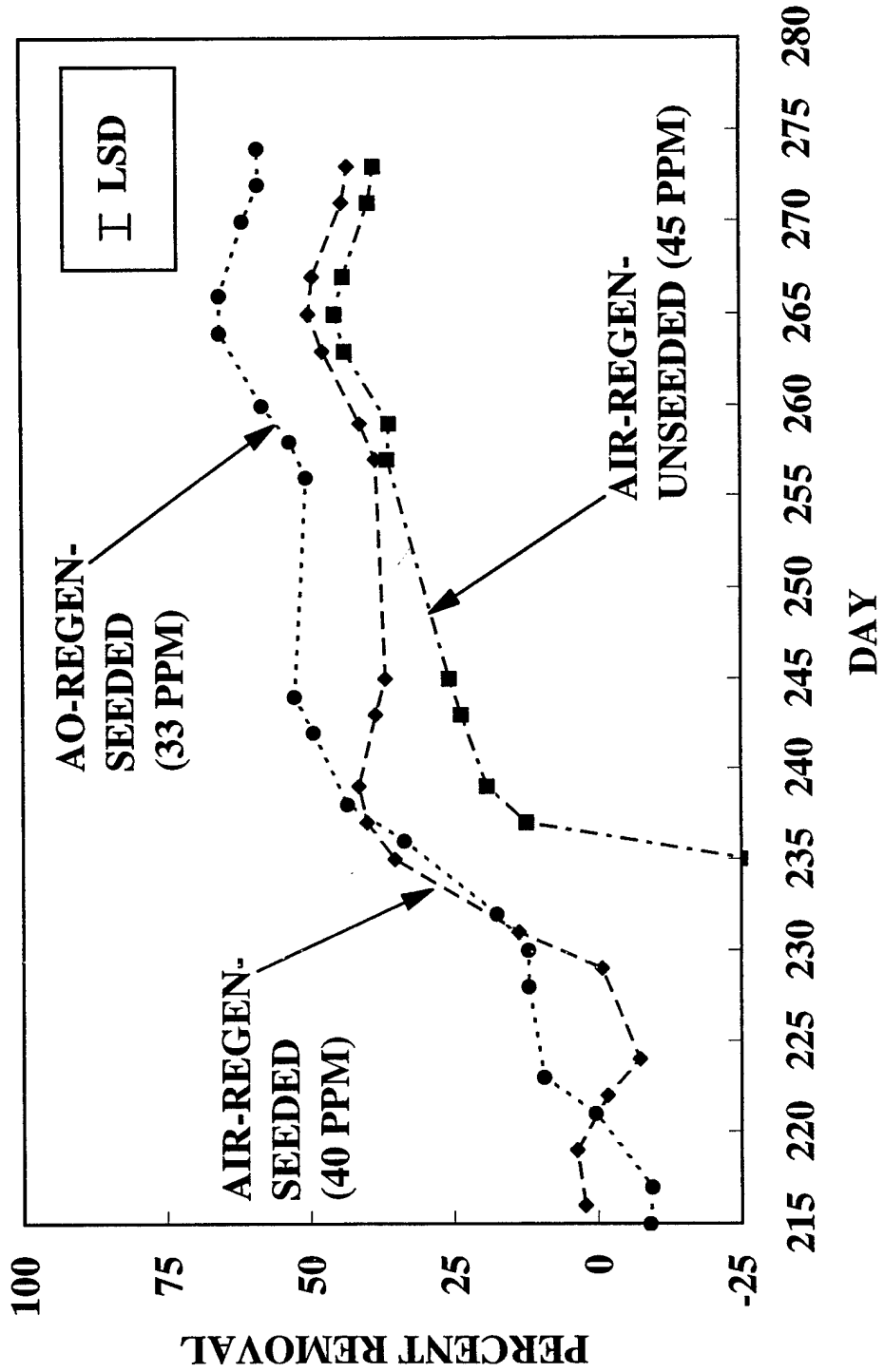

FIGURE 4-8: SEQUENTIAL GAC BIOFILTER REMOVAL EFFICIENCY AT 125 PPM MIBK, 148 SECOND EBCT

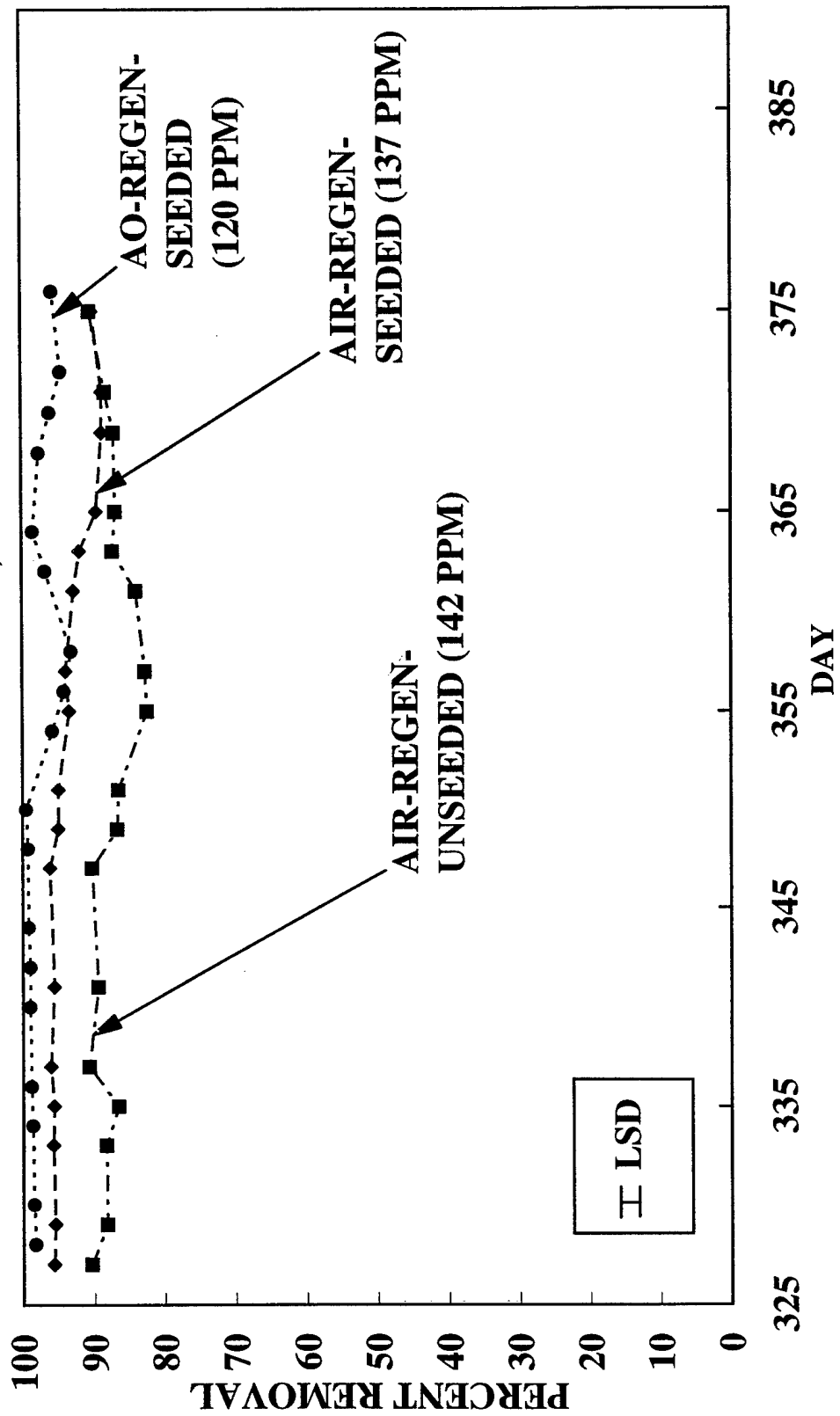

FIGURE 4-9 : OZONE PENETRATION THROUGH WET AND DRY GAC BEDS AFTER 1 HOUR

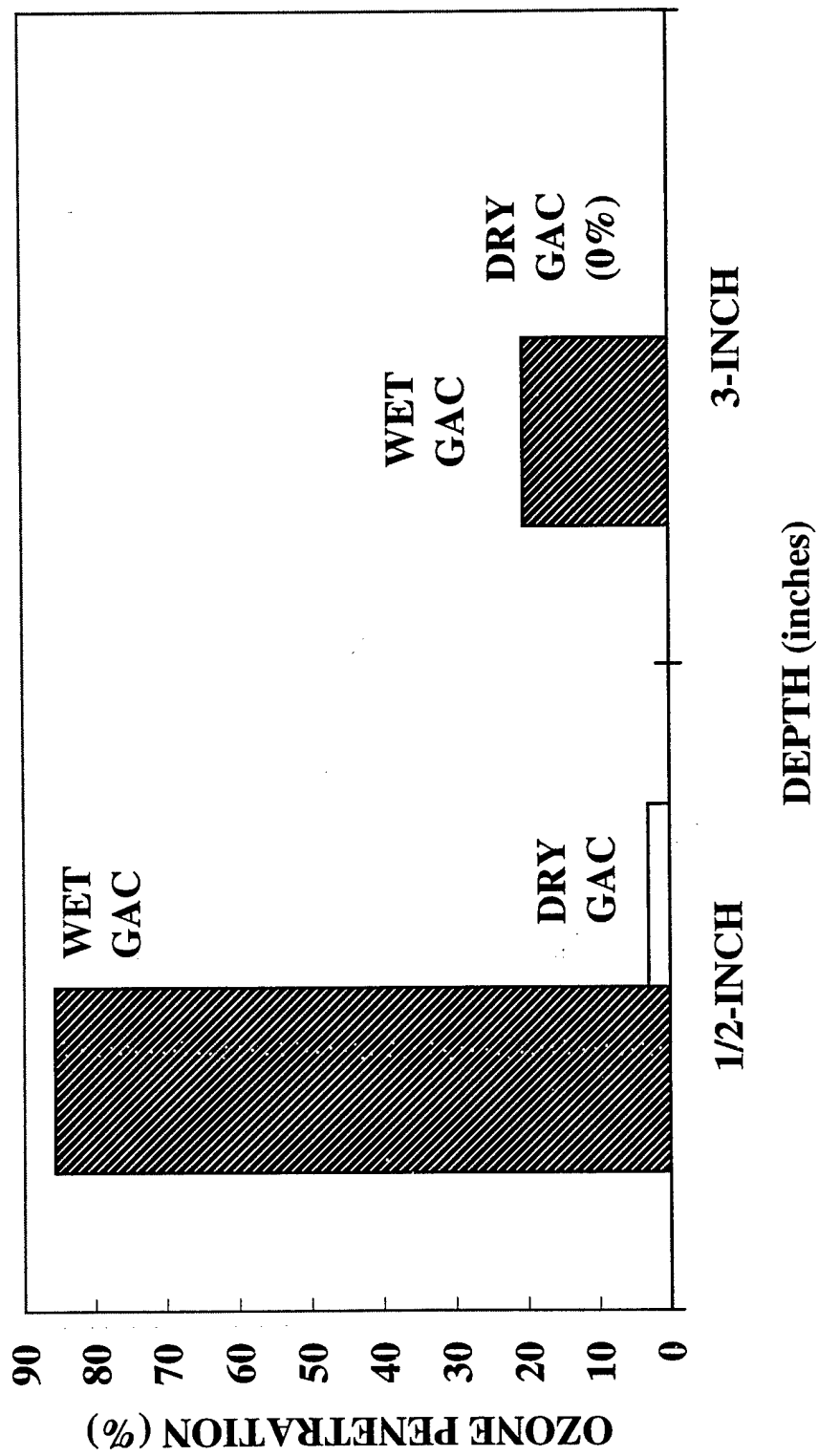
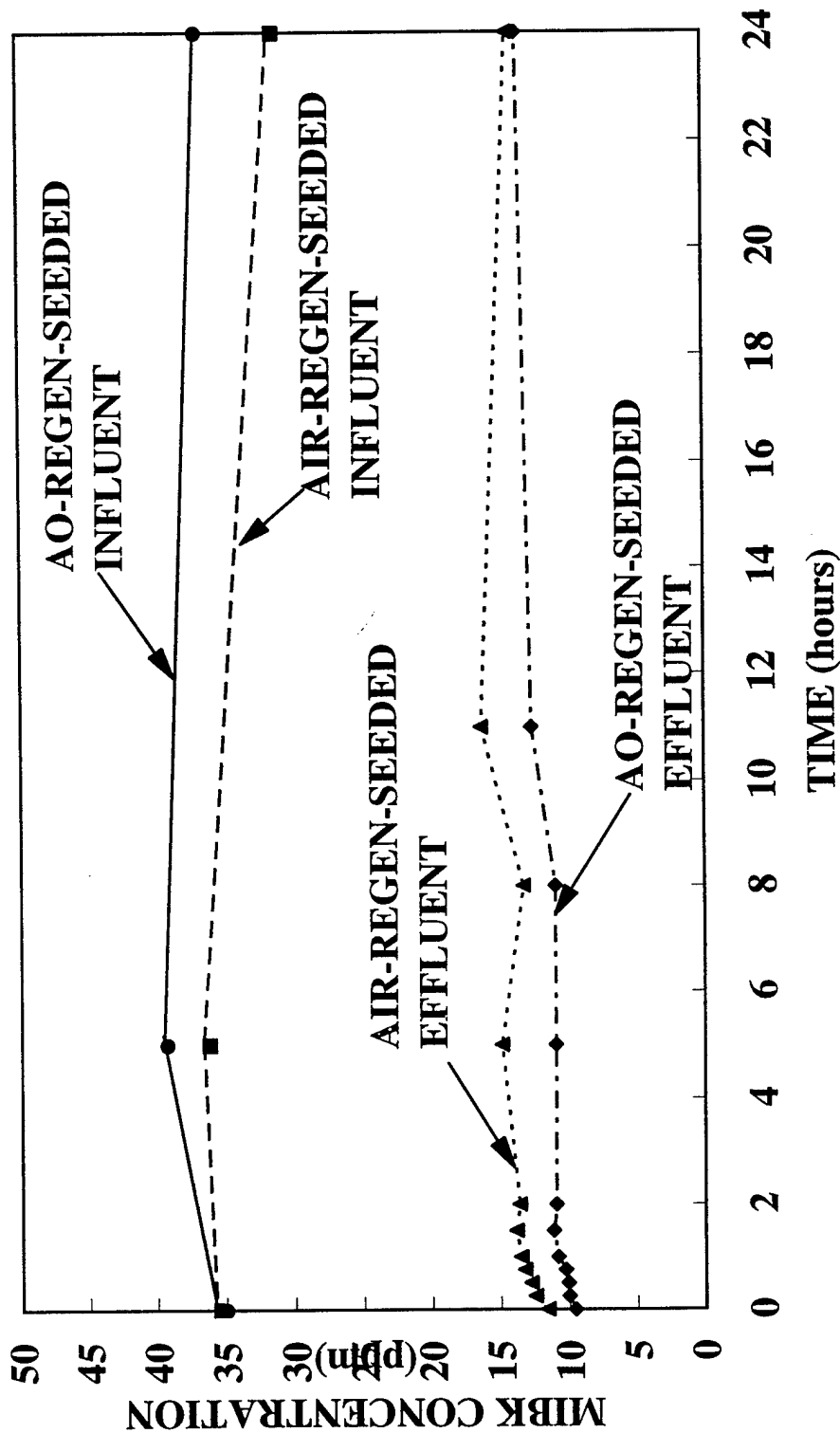

FIGURE 4-10: 24 HOUR EFFLUENT MIBK CONCENTRATION FROM SEQUENTIAL GAC BIOFILTER LOADED AT 35 PPM



**FIGURE 4-11: pH OF SEQUENTIALLY LOADED AND
REGENERATED GAC BIOFILTERS**

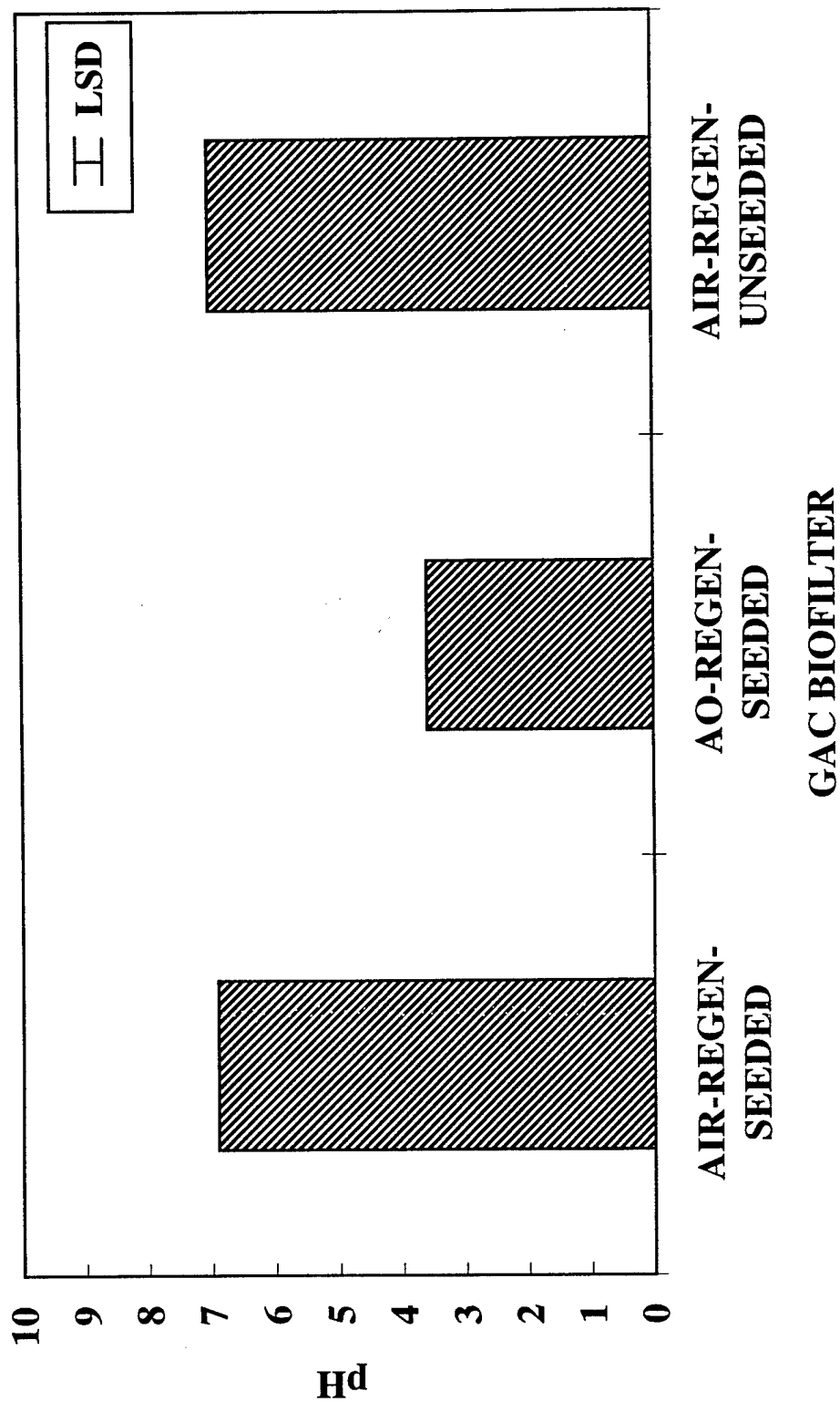
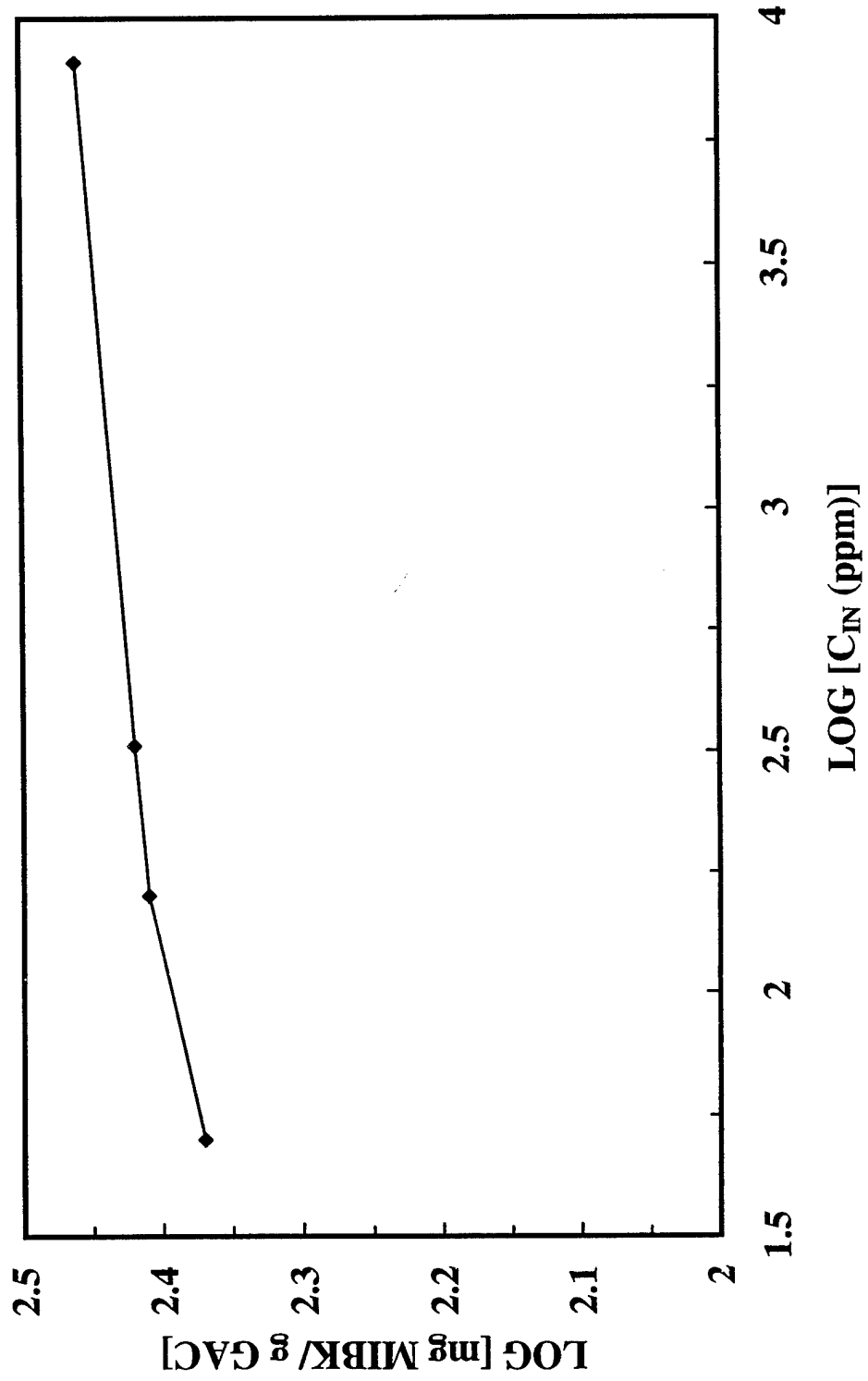

FIGURE 4-12: MIBK / COCONUT SHELL GAC ISOTHERM



CHAPTER 5

TREATMENT OF METHYL ISOBUTYL KETONE BY A SEQUENTIALLY LOADED AND REGENERATED GRANULAR ACTIVATED CARBON BIOFILTER

5.1 Abstract

The research described herein focuses on the use of a system consisting of two sequentially loaded and regenerated biologically active granular activated carbon beds. One of the beds was used to treat an air stream laden with MIBK while the second was subject to either humid air (no pollutant) or advanced oxidant laden humid air regeneration. Every 24 hours the loading and regenerating beds were switched so that the bed which had been loaded the previous 24 hours was then regenerated for the next 24 hours and vice-versa. The objective of this research was to show that biological treatment was responsible for the performance observed in field systems. Secondly the authors proposed to model the performance of the sequentially loaded and regenerated GAC biofilter with kinetic data that was derived from the GAC biofilter material [Dusenbury and Cannon 1997]. These systems have been operated continuously for over 12 months and they have shown continued removal of the pollutant from the waste air stream.

5.2 Introduction

Biofiltration is an application of commonly used biological treatment of pollutants to air pollution control [Bohn, 1992; Leson and Winer, 1991; Ottengraf, 1981; Hodge *et*

al, 1991; Shafeerdeen *et al*, 1993; Utiker *et al*, 1991]. Until recently, treatment of air pollution by biological means has received little notice. The method has now been accepted and employed with increasing frequency in Europe. This treatment process has emerged more slowly in the United States and is now just beginning to receive greater attention.

The research described herein focuses on the use of a system consisting of two biologically active granular activated carbon beds operated sequentially. One of the beds was used to treat an air stream laden with MIBK while the second was subject to either humid air (no pollutant) or advanced oxidant laden humid air regeneration. Every 24 hours the loading and regenerating beds were switched so that the bed which had been loaded the previous 24 hours was then regenerated for the next 24 hours and vice-versa. These systems have been operated continuously for over 12 months and they have shown continued removal of the pollutant from the waste air stream.

The objective of this research was twofold, first the authors intended to show that biological treatment was possible for conditions similar to which the field systems operate. Secondly the authors proposed to model the performance of the sequentially loaded system with kinetic data derived from the biofilter material. Development of the kinetic data is presented in Chapter 3.

5.3 Literature Review

5.3.1 BIOLOGICAL AIR POLLUTION CONTROL PROCESSES

Biological treatment of waste air streams is customarily been divided into two broad categories, I) Bioscrubbers, and II) Biofiltration [Ottengraf, 1981; Leson and Winer, 1991; Overcamp *et al.*, 1993]. In biofiltration the waste air passes through a solid porous media. This solid media serves as a matrix on which biological growth and subsequently biological oxidation of absorbed pollutants occurred.

In bioscrubbers which were not used herein, the waste air is contacted with a water stream and the pollutant migrates from the air to the water according to partitioning and the concentration gradient. The water loaded with the pollutant is then transferred to an oxidative reactor where the organics undergo biological treatment. These processes are often mass transfer limited and controlled by the solubility of the pollutant in question.

5.3.2 THEORETICAL MODELING AND DESIGN OF BIOFILTERS

In a fixed film biofilter, a support particle is surrounded by a wet biolayer consisting of water and microorganisms. As the contaminated waste-air stream flows around the particles there is continuous mass transfer between the gas phase and the biolayer (Figure 5-1). Soluble volatile pollutants and oxygen present in the air stream are partially dissolved in the liquid phase of the biolayer and diffuse through the layer as described by an effective diffusion coefficient D . As the compounds diffuse through the

biolayer they are aerobically degraded via microbial activity. A concentration gradient was therefore established in the biolayer which maintained a continuous mass flow of the contaminant from the gas phase into the wet biolayer.

Due to the small particle diameter of common filter materials and a generally low water solubility of the contaminants to be transferred, the mass transfer resistance in the gas phase can generally be neglected [Ottengraf, 1981]. Thus the process may be described by single-film mass-transfer. The gas is assumed to flow through the reactor in a plug flow manner. The biolayer thickness δ is assumed to be small compared to the diameter of the coated particle. The substrate utilization rate r_s may be developed from the expression proposed by Monod for microbial growth under substrate limited conditions assuming that the oxygen concentration in the biofilter is high enough to have no influence on the microbial degradation of the pollutant. In this case growth of the microorganisms in a continuous culture is limited by the amount of substrate available [Metcalf and Eddy, 1991]:

$$\mu = \mu_m \frac{C_L(z)}{K_s + C_L(z)} \quad (5-1)$$

where μ is the specific growth rate (t^{-1}), μ_m is the maximum specific growth rate (t^{-1}), C_L is the substrate concentration within the biolayer, and K_s is the half-velocity constant which corresponds to the substrate concentration at one-half the maximum growth rate, (mass/ unit volume). The microbial growth may be described by Haldane-Andrews kinetics when the substrate becomes inhibitory to degradation at increased concentrations.

In this model a inhibition term (C_L^2/K_i) is added to the denominator of the Monod equation. The substrate utilization rate (r_s) may be defined as:

$$r_s = -(r_g/Y) \quad (5-2)$$

where r_g is the rate of bacterial growth (mass/unit volume*t) and Y_b is the maximum yield coefficient (mg cells/mg substrate) defined as the ratio of the mass of cells formed to the mass of substrate consumed, measured during any finite period of logarithmic growth). The rate of microbial growth in both batch and continuous cultures may be defined as follows:

$$r_g = \mu X \quad (5-3)$$

where X is the concentration of microorganisms (mass/unit volume).

The differential equation describing the change in contaminant concentration c_L within the biolayer at steady-state conditions is:

$$D_e(\partial^2 C_L / \partial x^2) - r_s = 0 \quad (5-4)$$

where x is the penetration into the biofilm layer. The boundary conditions for this equation are defined by the equilibrium condition established at the I) air/biolayer interface and II) point where the concentration gradient of the compound goes to zero within the biolayer. The location of zero change in concentration in the biolayer is established by the biolayer thickness and the concentration gradient within the biolayer. The first boundary condition, the equilibrium at the air/biolayer interface, may be defined as follows from the principle of Henry's Law. If it is assumed that the conditions of interest in an air pollution control system occurs at low concentrations, the partition

coefficient will obey Henry's law:

$$p_s = H_s C_s \quad (5-5)$$

where p_s is the partial pressure of the substrate, H_s is the Henry's constant, and C_s is the concentration in the liquid phase. For the case investigated in this work all concentrations of MIBK were below 200 ppm and the saturation pressure for MIBK at 20 °C is 19851 ppm. The Henry's law constant for MIBK is 0.00447. It can further be shown that:

$$m_s = H/RT \quad (5-6)$$

where m_s is the distribution coefficient of the substrate, R is the universal gas constant per mole, and T is the temperature (in K). The boundary condition may now be defined by:

$$\text{(at } x = 0, \text{ and } z = z), C_L(0,z) = C_G(0,z)/m_s \quad (5-7)$$

where z is the height of the biofilter (m), C_L and C_G are the concentrations in the liquid(biofilm) and gas phases respectively.

The second boundary condition, the location where the concentration gradient equals zero, is a function of the rate of the reaction. For concentrations of contaminant much lower than the half-saturation constant ($C_L \ll K_s$) the rate expression approaches first order kinetics in substrate concentration because equation 5-1 approaches

$$\mu = \mu_{\max} C_L(z)/K_s.$$

Under these conditions the boundary condition is met at $x = \delta$, where δ is the biofilm thickness. For biofilms that are attached to GAC, the mathematical modeling is appropriate when δ is half the biofilm thickness, since substrate (MIBK) can diffuse into the biolayer from the air phase and the adsorbed phase.

If the concentration of the contaminant is much higher than the half-saturation constant ($C_L \gg K_s$) the rate expression approaches zero order kinetics in substrate concentration because equation 5-1 approaches $\mu = \mu_{max}$. Previous experimental work has shown that this condition is often encountered in the treatment of many common volatile pollutants [Ottengraf, 1981]. Under zero order conditions two extremes can be manifest: either reaction limitation or diffusional limitation [Ottengraf, 1981]. In reaction limited situations there is no diffusional limitation in the wet biolayer. This means the entire depth of the biolayer is fully active ($x = \delta$) and the degradation rate is controlled by the reaction rate. In contrast, under diffusional limited conditions reaction rate is more rapid than the diffusion rate, and substrate becomes progressively more depleted with penetration depth into the biolayer. Therefore, the biolayer is not active over its entire depth and the penetration of the contaminant can be less than the biolayer thickness ($x < \delta$). In this case the degradation rate is controlled by the rate of diffusion through the biolayer. A theoretical model describing the elimination of carbon sources in a filter bed will be applied to each of the three cases listed previously. The greatest focus will be placed on the first order kinetics condition, since all of the sequentially loaded and regenerated GAC biofilter tests employed substrate concentrations that conformed to the first order kinetics zone.

5.3.2.1 FIRST ORDER KINETICS

For first-order kinetics, The differential equation describing the concentration of a carbon source inside the biolayer will be solved with the first boundary condition as listed previously and the second boundary condition as given by:

$$\text{at } x = \delta, (dC_L/dx) = 0 \quad (5-8)$$

At a constant microbial cell concentration of X the solution to the differential equation with the boundary conditions as described is [Ottengraf, 1981]:

$$\frac{C_L}{C_G/m} = \frac{\cosh\{\phi_1(1-\sigma)\}}{\cosh\phi_1} \quad (5-9)$$

where $\phi_1 = \delta(k_1/D_e)^{1/2}$ is the Theile number for a 1st order reaction and $\sigma = x/\delta$ is the dimensionless length coordinate in the biolayer. The first order reaction rate constant k_1 is defined as:

$$k_1 = \frac{\mu_{\max}}{Y K_s} * X \quad (5-10)$$

A mass balance may be written for the contaminant in the gas phase which is equal to the mass transferred to the biofilm:

$$Q_G C_G(z) = Q_G [C_G(z) + dC_G(z)] + N(z) \quad (5-11)$$

$$dC_G = -N(z)/Q_G \quad (5-12)$$

where Q_G is the volumetric flow rate and $N(z)$ is the mass transfer into the biofilm at any height z in an elemental volume $A dz$ and may be written as:

$$N(z) = [-D_e(\partial C_L/\partial x)_{0,z}] a A dz \quad (5-13)$$

$$N(z) = \frac{D_e C_G}{\delta m_s} \phi_1 \tanh \phi_1 a A dz \quad (5-14)$$

where A is the cross-sectional area and a is the interfacial area per unit volume. The mass balance for the contaminant in the gas phase may now be written as:

$$dc_G = -\frac{D_e C_G a}{\delta m_s U_G} \phi_1 \tanh \phi_1 dz \quad (5-15)$$

where U_G is the average gas velocity, $U_G = Q_G/A$

Integrating over the height of the bed (Z), one obtains:

$$\int \frac{dC_G}{C_G} = \int \frac{D_e a}{\delta U_G m_s} \phi_1 \tanh \phi_1 dz \quad (5-16/17)$$

$$\frac{C_G(z)}{C_G(0)} = \exp\left\{-\frac{ZaD_e}{m_s \delta U_G} \phi_1 \tanh \phi_1\right\} = \exp\{-N_r\}$$

where N_r is often denoted as the number of reaction units. The overall removal efficiency (η) for the biofilter is then:

$$\eta_{\text{h}}(\text{first-order}) = 1 - \left(\frac{C_G(z)}{C_G(0)}\right) = 1 - \exp\left\{-\frac{ZK_1}{m_s U_G}\right\} \quad (5-18)$$

where K_1 is related to the reaction unit by the expression:

$$N_r = (\text{EBCT} * K_1) m_s$$

and

$$K_1 = (a/\delta) D_e \phi_1 \tanh \phi_1 \quad (5-19)$$

5.3.2.2 ZERO ORDER KINETICS REACTION LIMITED

The differential equation describing the concentration of a carbon source inside the biolayer will be solved with the first boundary condition as described by Henry's Law and the second boundary condition where the concentration gradient of the substrate goes to zero as given by:

$$x = \delta, (dC_L/dx) = 0 \quad (5-20)$$

The solution to the differential equation describing the concentration of the carbon source within the biolayer with the boundary conditions described is [Ottengraf, 1981; Heinsohn and Kabel, 1995]:

$$\frac{C_L(z)}{C_G(z)/m_s} = 1 + \frac{1}{2} \frac{\phi_0^2}{C_G(z)/C_G(0)} (\sigma^2 - 2\sigma) \quad (5-21)$$

where ϕ_0 is the Thiele number for zero-order kinetics

$$\phi_0 = \delta \sqrt{\frac{k_0 m_i}{D_e C_G(0)}} \quad (5-22)$$

and k_0 is the zero order reaction constant

$$k_0 = \frac{\mu_{\max}}{Y_s} X \quad (5-23)$$

The mass of pollutant transferred (accumulated) into the biofilm from an element of gas stream $A dz$ at a location of $z = z$ is

$$N(z) = -D_e \left(\frac{\partial C_L(z)}{\partial x} \right)_{0,z} a A dz = -k_0 \delta a A dz \quad (5-24)$$

The pollutant removed from the gas phase is again equal to the mass absorbed and/or

assimilated by the biofilm and a mass balance may be written as:

$$\begin{aligned} Q_G C_G(z) &= Q_G (C_G(z) + dC_G) + N(z) \\ dC_G &= -\frac{N(z)}{Q_G} = -\frac{k_0 \delta a A}{AU_G} dz = -\frac{k_0 \delta a}{U_G} dz \end{aligned} \quad (5-25/26)$$

Integrating the equation over the length of the biofilter:

$$\frac{C_G(z)}{C_G(0)} = 1 - \frac{k_0 a \delta A dz}{AU_G} = 1 - \frac{K_0 z}{U_G C_G(0)} \quad (5-27)$$

where $K_0 = k_0 * a * \delta$ is the apparent zero order rate constant.

The removal efficiency η_0 over the length of a biofilter for reaction limited zero order kinetics is:

$$\eta_0(\text{reaction - limited}) = 1 - \frac{C_G(z)}{C_G(0)} = \frac{K_0 Z}{U_G C_G(0)} \quad (5-28)$$

6.3.2.3 ZERO ORDER KINETICS DIFFUSION LIMITED

The differential equation describing the concentration of a carbon source inside the biolayer will be solved with the first boundary condition at the air/biolayer interface and the second boundary condition where the concentration gradient of the carbon source goes to zero as given by:

$$x = \lambda, (dC_{Li}/dx) = 0 \quad (5-29)$$

The second boundary condition states that the concentration of the carbon source in the biofilm will go to zero before completely penetrating the biofilm since the rate of diffusion is not sufficient to keep pace with the rate of substrate utilization, this situation is possible at low gas phase concentrations [Ottengraf, 1981]. The Theile number may be

used to predict the conditions under which diffusion limitation will occur. The critical Theile number at which diffusion limitation just begins to occur can be shown to be [Ottengraf, 1981]:

$$\phi_{cr} = \delta \sqrt{\frac{k_0 m_s}{D_e C_G(z)}} = \sqrt{2} \quad \text{if } > \sqrt{2} \text{ diffusion limited} \quad (5-30)$$

if $< \sqrt{2}$ reaction limited

At gas phase concentrations lower than the critical value the degradation rate will be controlled by the diffusion rate and not the reaction rate. When the diffusion rate is limiting, the solution to the differential equation describing the concentration of the carbon source within the biolayer with the boundary conditions described is [Ottengraf, 1981; Heinsohn and Kabel, 1995]:

$$\frac{C_L(z)}{C_L(z)/m_s} = 1 + \frac{1}{2} \frac{\phi_0^2}{C_G(z)/C_G(0)} \left(\sigma^2 - 2\sigma \frac{\lambda}{\delta} \right) \quad (5-31)$$

The concentration of the contaminant will go to zero at $\sigma = \lambda/\delta$, so the penetration thickness λ may be calculated as follows:

$$\lambda = \sqrt{\frac{2D_e C_G(z)}{k_0 m_s}} \quad (5-32)$$

A differential gas phase mass balance on the contaminant may now be constructed for the biofilter at a height z :

$$-U_G \frac{dC_G(z)}{dz} = N * a = k_0 * \lambda * a \quad (5-33)$$

Solving the differential mass balance for the boundary conditions presented at the beginning of the section after substituting for λ gives the following:

$$\frac{C_G(z)}{C_G(0)} = \left(1 - \frac{Z^* a}{U_G} \sqrt{\frac{k_0 D_e}{2m_s C_G(0)}} \right)^2 \quad (5-34)$$

The removal efficiency over the length of a biofilter for diffusion limited zero order kinetics is:

$$\eta_{0,d}(\text{diffusion limited}) = 1 - \frac{C_G(z)}{C_G(o)} = 1 - \left(1 - \frac{Z^* a}{U_G} \sqrt{\frac{k_0 D_e}{2m_s C_G(0)}} \right)^2 \quad (5-35)$$

The removal efficiency over the length of a biofilter under the conditions described previously may be summarized as follows:

$$\eta_1(\text{first - order}) = 1 - \left(\frac{C_G(z)}{C_G(0)} \right) = 1 - \exp \left\{ -\frac{ZK_1}{m_s U_G} \right\} \quad (5-18)$$

$$\eta_0(\text{reaction - limited}) = 1 - \frac{C_G(z)}{C_G(o)} = \frac{K_0 Z}{U_G C_G(o)} \quad (5-28)$$

$$\eta_{0,d}(\text{diffusion limited}) = 1 - \frac{C_G(z)}{C_G(o)} = 1 - \left(1 - \frac{Z^* a}{U_G} \sqrt{\frac{k_0 D_e}{2m_s C_G(0)}} \right)^2 \quad (5-35)$$

5.4 Materials and Methods

5.4.1 GAC BIOFILTER SYSTEM

Sequentially loaded and regenerated bench-scale reactors have been constructed to operate in a manner analogous to a commercially available air pollution control system manufactured by Terr-aqua Environmental Systems (TAES) (Figure 4-1). The bench-scale systems consist of two GAC biofilter beds. One of the beds treated a simulated waste air stream while the second underwent regeneration. The beds were reversed and switched roles in a cyclic fashion. Two bench-scale systems have been used to compare the performance when run under different operating conditions. These different conditions are; (a) a humid air regeneration of a GAC biofilter system seeded with filamentous microorganisms from a TAES field site (*air-regen-seeded*) and (b) ozone/associated oxidant regeneration of a seeded GAC biofilter (*AO-regen-seeded*). Details of the sequentially loaded and regenerated GAC biofilter operation was described in Chapter 4.

5.5 Results and Discussion:

5.5.1 SEQUENTIALLY LOADED AND REGENERATED GAC BIOFILTER

PERFORMANCE

The sequentially loaded and regenerated GAC biofilters were operated for over 12 months. Over this time period the biofilters treated influent air streams with methyl

isobutyl ketone (MIBK) concentrations from 35 ppm to 150 ppm. The range 35 to 150 ppm represents concentrations commonly encountered in industrial applications that employ the Terr-Aqua system, according to the manufacturer of that system. The reactors were also operated at three different retention times to allow the authors to evaluate the effect of flow rate, as well as, influent concentration on the system. Varying both the flow rate and influent concentration was also necessary to evaluate the parameters within the biofilter model. These flow rates corresponded to the following empty bed contact times, 11 seconds, 37 seconds, and 148 seconds.

After the influent concentration to the biofilter was set, the system was allowed to reach a pseudo-steady state condition. This condition was defined as occurring when both the influent and effluent concentrations had leveled out at steady-state levels (Figure 5-2). This figure shows the time (day of operation) on the x-axis and the concentration of MIBK in the air-phase on the y-axis. One line represents the influent concentration while the second line represents the effluent concentration. Once the system had reached this pseudo steady-state condition the system removal efficiency and rate were determined as the average removal rate and efficiency of the plateau region (Table 5-1). The removal efficiency was calculated as one minus the effluent VOC concentration (ppm) divided by the influent concentration.

Figures 5-2 through 5-3 show the influent and effluent concentrations for both the *AO-regen-seeded* and *air-regen-seeded* biofilters. These Figures demonstrate the effect of changing the influent conditions on the system. After the influent conditions are adjusted the system takes approximately one to two weeks to reach the new equilibrium

Table 5-1 Sequentially Loaded and Regenerated GAC Biofilter Steady-State Performance

Reactor	Influent Concentration (ppm)	Retention Time (sec)	Mass Loading (mg/hr)	Effluent Concentration (ppm)	Removal Efficiency (percent)	Removal Rate (g/m³*hr)
Seeded	152	11	42	125	18	44
Ozonated	119	11	33	92	23	43
Unseeded	117	11	32	100	13	24
Seeded	146	37	10	80	45	26
Ozonated	137	37	9.4	82	41	22
Unseeded	163	37	11	92	44	28
Seeded	89	37	6.1	52	41	14
Ozonated	73	37	5.0	36	51	15
Unseeded	71	37	4.9	52	27	8
Seeded	40	37	2.8	22	44	7
Ozonated	33	37	2.3	15	55	7
Unseeded	45	37	3.1	31	33	6
Seeded	137	148	2.4	10	93	13
Ozonated	120	148	2.1	3	97	11
Unseeded	142	148	2.4	17	88	12

state. When the influent concentration was reduced the effluent concentration at first remained the same as if was before the adjustment. The effluent concentration then

slowly dropped to its new equilibrium state. At the higher mass loadings this resulted in a period where the effluent concentration was higher than the influent concentration, days 175 to 180 and 220 to 225. This phenomena may be explained by the GAC's equilibrium isotherm. While this isotherm is rather flat [Dusenbury and Cannon, 1996] there is still a slight decrease in the GAC's capacity for MIBK with decreasing influent concentration. Therefore as the influent concentration is reduced MIBK desorbed from the GAC to achieve an equilibrium state with this new concentration. When the flow rate was reduced from 1.12 L/min to 280 mL/min a similar effect was apparent. However, when the flow rate was reduced from 280 mL/min to 70 mL/min no desorption was evident. In this instance the microbial degradation rate of the VOC was great enough to mask the desorption from the GAC.

The detention time within the GAC biofilter has a larger effect on the efficiency of the biofilter to remove contaminants from the waste air stream than the contaminant concentration. A four fold increase in detention time, from 11 seconds to 44 seconds, led to a doubling of the removal efficiency, 18% to 45% for the *air-regen-seeded* and 23% to 41% for the *AO-regen-seeded*. However, a three and a half fold decrease in influent concentration, from 140 ppm to 40 ppm, led to little change in the GAC biofilter removal efficiency, 45% to 44% for the *air-regen-seeded* and 41% to 51% for the *AO-regen-seeded* biofilter.

5.5.2 DETERMINATION OF MODEL PARAMETERS AND SUITABILITY FOR THE UNOZONATED GAC BIOFILTER

Evaluation of the biofilm kinetic parameters through the use of fed-batch kinetic studies has shown that the biofilm may be described using a Haldane-Andrews type kinetic equation with the following biodegradation constants: $k_{max} = 25$ ppm MIBK/HR*g biofilter material, $K_s = 675$ ppm MIBK, and $K_i = 7040$ ppm MIBK (Chapter 3). Therefore, all operating conditions investigated in this study (35 to 150 ppm) and most of the operating conditions of interest for treatment of waste air streams from industrial processes may be approximated by first order kinetics since it may be considered that 150 ppm < 675 ppm. The apparent first-order rate constant was determined to be $k_1 = 0.024$ hr⁻¹ * (g biofilter material)⁻¹ by the fed-batch kinetic studies. This parameter was estimated by performing a linear regression of the data in the first order region (< 500 ppm MIBK) of the fed-batch kinetic study data, as described in Chapter 3. The efficiency for a biofilm with first-order kinetics was derived in section 5.3.2.1 and was characterized by equation 6-18:

$$\eta_1(\text{first-order}) = 1 - \left(\frac{C_G(z)}{C_G(0)} \right) = 1 - \exp \left\{ - \frac{ZK_1}{m_s U_G} \right\}$$

In order to model the sequentially loaded and regenerated GAC biofilter using this theory the following constants must be determined: Z = the biofilter bed depth (m), m_s = the unitless Henry's constant. The term K_1 was defined by equation 5-19:

$$K_1 = (a/\delta)D\phi_1 \tanh\phi_1$$

D = the diffusion through the biofilm, the term a/δ , which is the interfacial area divided by the biolayer thickness, was considered constant based on the assumption of constant biomass within the biofilter. The Theile number was characterized as $\phi_1 = \delta \cdot (k_1/D)^{1/2}$ and k_1 = the apparent first order rate constant.

The biofilter bed depth was fixed by the experimental apparatus and was 0.1524 m in all tests conducted in this study. Estimates must be calculated for the apparent diffusivity and the distribution coefficient or dimensionless Henry's constant. The dimensionless Henry's constant (m_s) was predicted to be 0.004469 using the method and data presented in the Handbook of Environmental Data on Organic Chemicals [Verschueren 1996]. The diffusivity was approximated from fundamental physical characteristics by using The Hayduk and Laudie Method as presented in the Handbook of Chemical Property Estimation Methods [Lyman *et al*, 1990]. In this method, diffusivity is computed as $7.1844 \times 10^{-10} \text{ m}^2\text{s}^{-1}$ and modified by multiplying by an interaction factor of 0.7 due to the structure of the biofilm arriving at an apparent value that conforms to the data of La Cour and Harremoes [1984]. A value of $5.0291 \times 10^{-10} \text{ m}^2\text{s}^{-1}$ was used in all calculations.

The interfacial area per unit volume (a) was determined as $1.9 \text{ m}^2\text{m}^{-3}$ based on a best fit regression of the experimental data (Figure 5-4). The average gas velocity was used as the dependent variable in the determination of interfacial surface area (a) and the reciprocal of the average gas velocity will be used as the design variable after the model is defined.

The model was then plotted with the removal efficiency as a function of the reciprocal of the average gas velocity (Figure 5-5) using the interfacial area per unit volume as determined and remaining constants as estimated previously. The data of the model may be compared with the experimental data as shown in Figure 5-5. This Figure shows that the data was well predicted by the model even in the case of three different influent MIBK concentrations at a single influent flow rate (280 mL/min). The model derived by Ottengraf [1984] for first order kinetics indicates that removal efficiency should be strongly dependent on bed depth divided by the average gas velocity (or the EBCT) and independent of the influent substrate concentration. Concurrently, the data for the *AO-regen-seeded* loaded and regenerated GAC biofilter shows a strong dependency on the EBCT as predicted by the model and no dependency based on the influent concentration.

5.5.3 DETERMINATION OF MODEL PARAMETERS AND SUITABILITY FOR THE OZONATED GAC BIOFILTER

The data for the ozonated sequentially loaded and regenerated GAC biofilter was also modeled using the first order kinetics removal efficiency equation as derived in section 5.3.2.1. The same values as used in the unozonated condition were used for all the estimated parameters. The fed-batch kinetic studies indicated that the biodegradation parameters were also the same as those in the unozonated instance. However, this leads to a larger interfacial surface area per unit volume in the ozonated case. This appears to be highly unlikely since both GAC biofilters were constructed using GAC from the same

batch and pvc from the same pipe. This suggests that there was a difference in biodegradation parameters in the ozonated GAC biofilter which was not identified by the fed-batch kinetic studies. The equal performance of biofilter material from the *AO-regen-seeded* and *air-regen-seeded* GAC biofilters in the fed-batch kinetic studies indicated that the microbial kinetics were similar and the advanced oxidants created a physical-chemical change within the reactor during regeneration leading to enhanced biodegradation. The physical-chemical change could be either enhanced desorption or degradation of MIBK via oxidation (Chapter 4).

There appears to be a small dependence on the influent concentration in the removal efficiency of the ozonated sequentially loaded and regenerated GAC biofilter that does not agree with the model prediction. This may be an effect of the advanced oxidants not accounted for by the model.

5.6 Summary and Conclusions

In summary an unozonated and ozonated sequentially loaded and regenerated GAC biofilter were modeled using the theory of biofiltration as presented by Ottengraf [1981]. The removal efficiency and influent flow rate were monitored during experimentation. Values for physical and chemical parameters were either defined by the experimental system or estimated from available methods and data. A value for the interfacial surface area per unit volume was calculated using experimental data and estimated values by the model. With the estimated and calculated values the removal

efficiency of the sequentially loaded and regenerated GAC biofilter may now be predicted as a function of the influent flow rate.

The data for the *air-regen-seeded* biofilter was well described by the model. The *AO-regen-seeded* biofilter showed a slight dependence on the influent concentration which was not predicted by the model. However, the trend for the removal efficiency of the ozonated GAC biofilter was predicted by the model.

FIGURE 5-1: BIOPHYSICAL MODEL FOR BIOFILTER BIOFILM

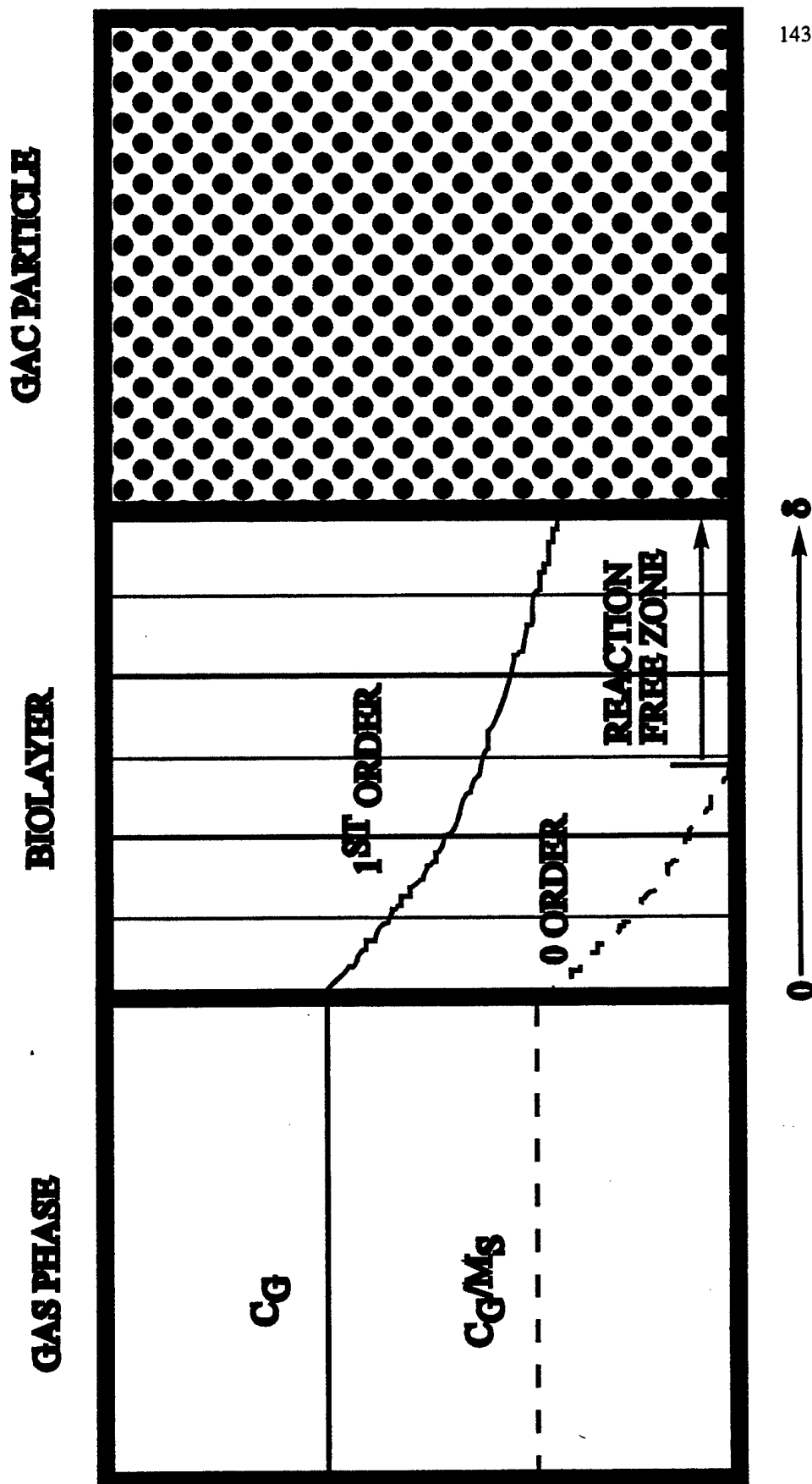
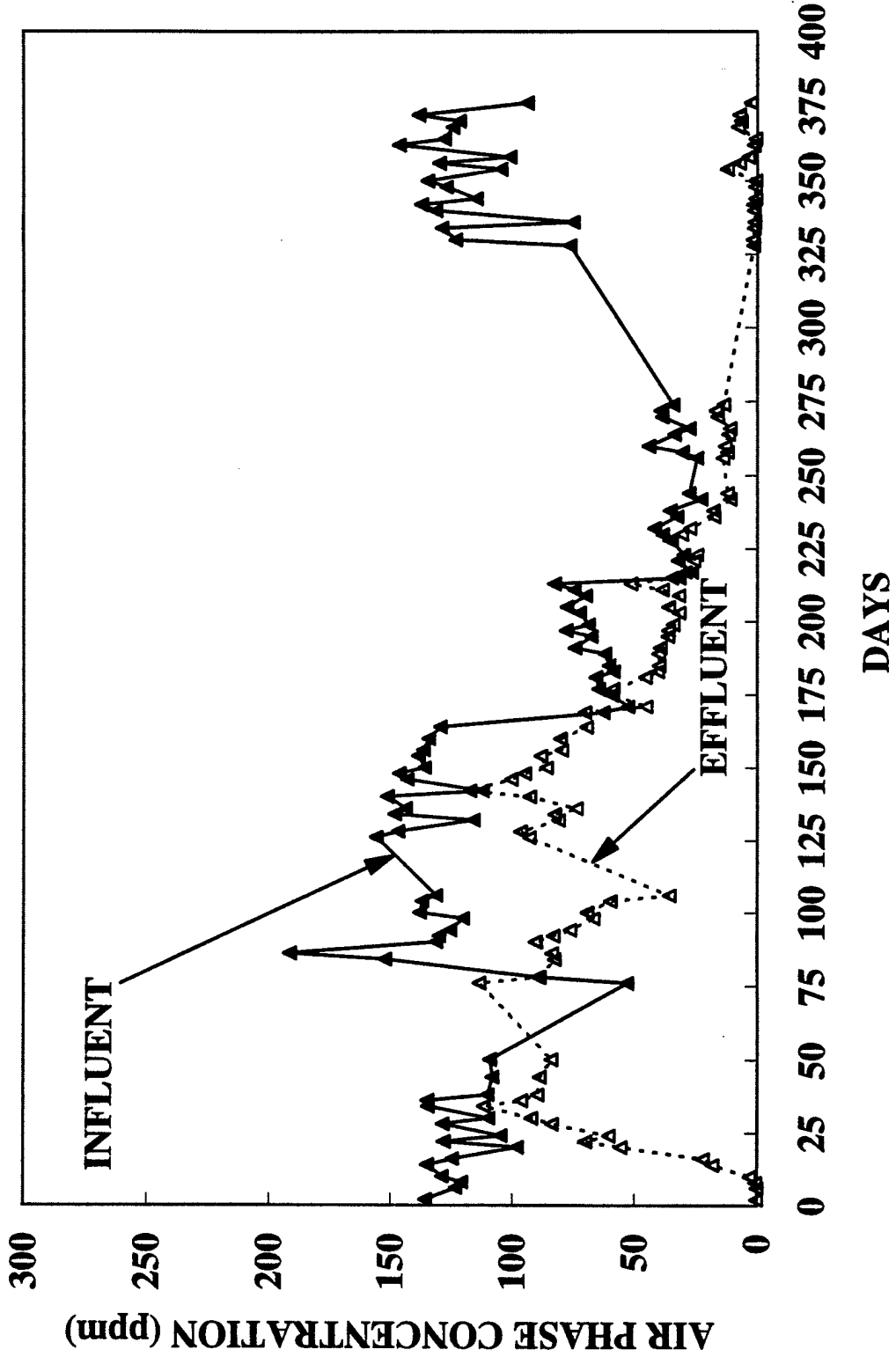

FIGURE 5-2: AO-REGEN-SEEDED GAC BIOFILTER INFLUENT AND EFFLUENT MIBK CONCENTRATIONS



**FIGURE 5-3: AIR-REGEN-SEEDED GAC BIOFILTER
INFLUENT AND EFFLUENT MIBK CONCENTRATIONS**

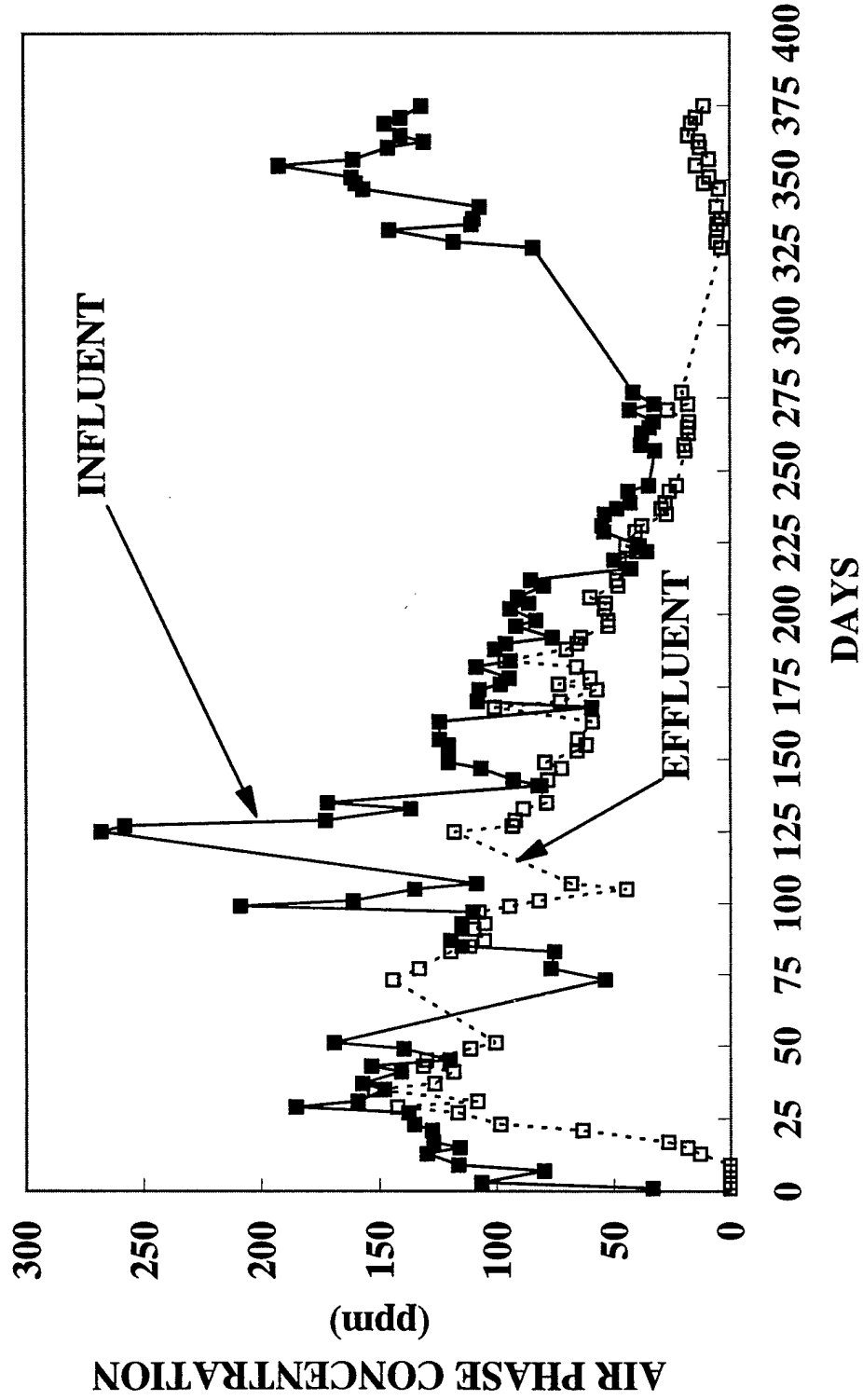
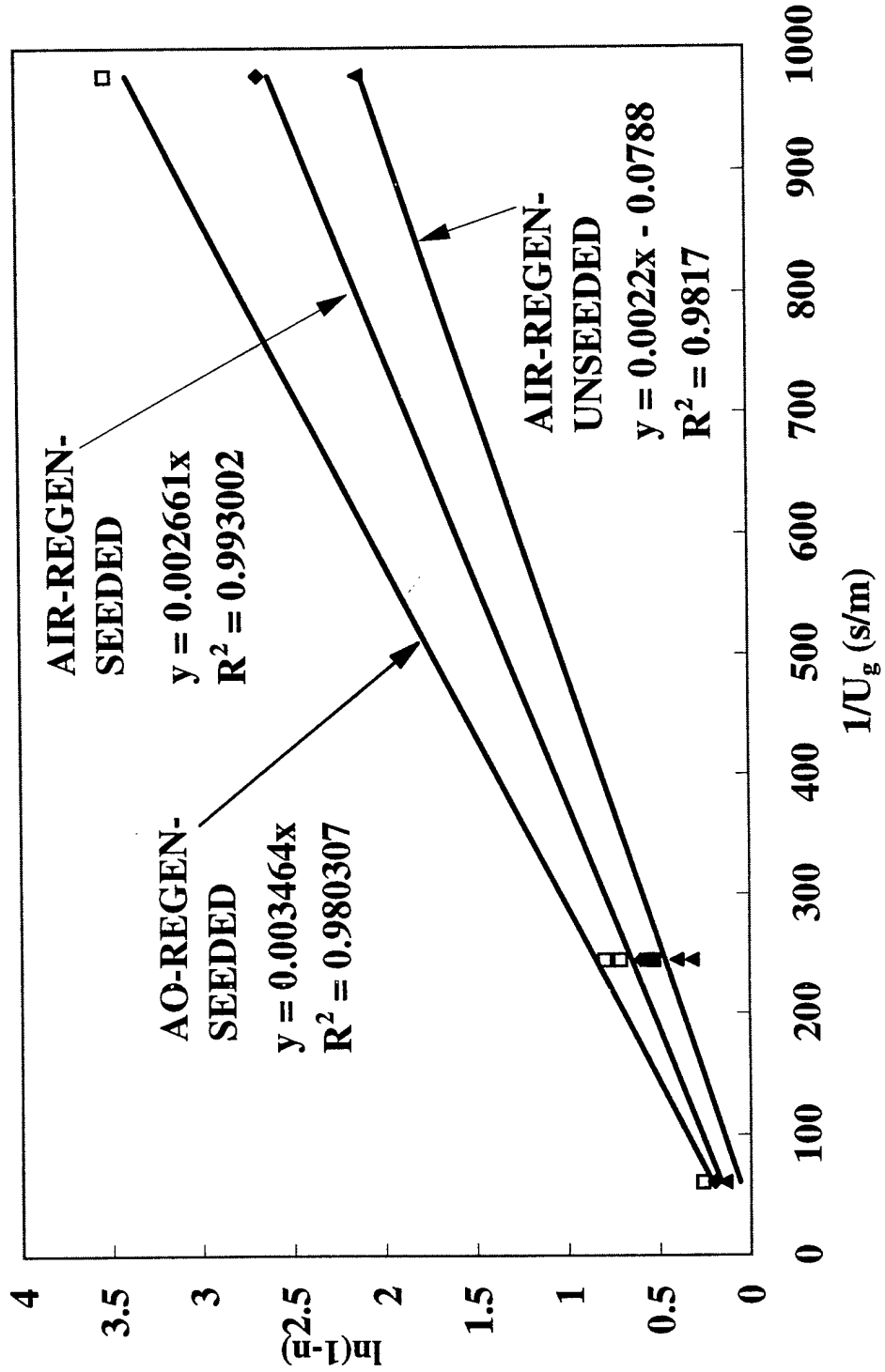
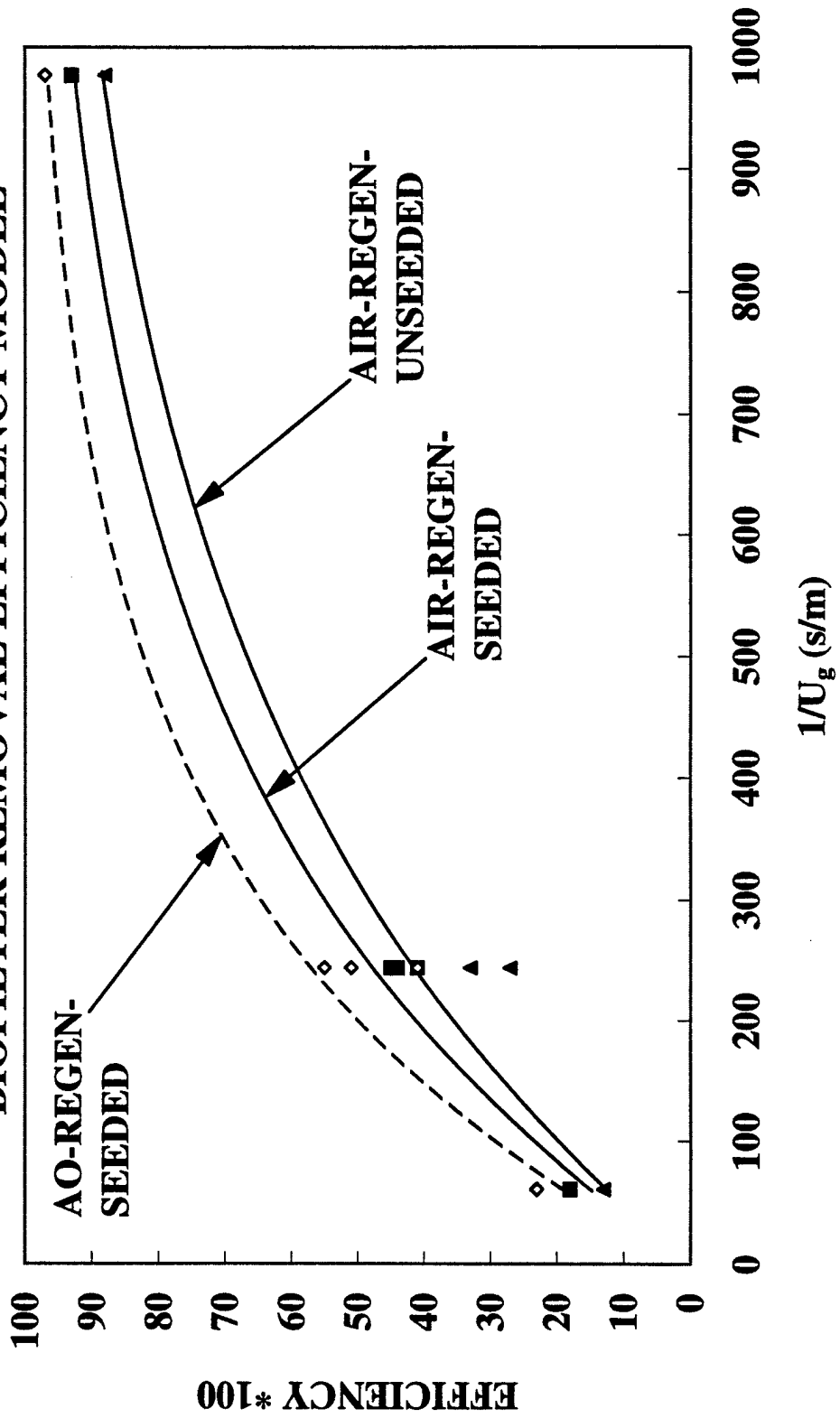

FIGURE 5-4: RECIPROCAL GAS VELOCITY VERSUS NATURAL LOG OF EFFICIENCY



**FIGURE 5-5: OTTENGRAF FIRST ORDER KINETICS
BIOFILTER REMOVAL EFFICIENCY MODEL**



CHAPTER 6 SUMMARY AND CONCLUSIONS

6.1 Summary

6.1 SUMMARY

The research described herein has evaluated a UV/ozone in-situ regeneration treatment of sequentially loaded and regenerated GAC biofilters used for removing MIBK from waste-air streams. Exploration has been conducted in three primary areas. The areas are, (a) GAC biofiltration including, UV/Ozone treatment of sequentially loaded and regenerated GAC biofilters, (b) biofilter biofilm kinetics, and (c) UV/ozone treatment of virgin and loaded GAC.

The unique operation of this system had a GAC biofilter alternately exposed to a simulated waste air stream that is laden with MIBK for 24 hours, followed by exposure to a regeneration air stream for 24 hours. Sequentially loaded and regenerated bench-scale reactors have been constructed to operate in a manner analogous to a commercially available air pollution control system manufactured by Terr-aqua Environmental Systems (TAES). Each of these bench-scale systems consisted of two GAC biofilter beds. One of the beds treated a simulated waste air stream while the second underwent regeneration. Three bench-scale systems have been used to compare the performance when run under different operating conditions. These different conditions have been; (a) a humid air regeneration of a GAC biofilter system seeded with filamentous microorganisms from a TAES field site (*air-regen-seeded*), (b) a humid air regeneration of an unseeded GAC

biofilter (*air-regen-unseeded*), and (c) ozone/ associated oxidant regeneration of a seeded GAC biofilter (*AO-regen-seeded*). These beds were run in an cyclic fashion with one bed treating the MIBK laden air stream for 24 hours while the second was regenerated then their roles were reversed for the following 24 hours. The second bed was regenerated with either humid air or humid air which has passed through the UV reactor producing ozone and associated oxidants. The effluent from the regenerating bed is fed back into the bed being loaded so the only emission from the system is from the bed being loaded.

The sequentially loaded and regenerated GAC biofilters have been operated under several different conditions for over 12 months total time in this research. These conditions include loading at nominal concentrations of 125 ppm with a 11 second empty bed contact time (EBCT), 140 ppm with a 37 second EBCT, 75 ppm with a 37 second EBCT, 35 ppm with a 37 second EBCT, and 135 ppm with a 148 second EBCT. In all cases MIBK was used as a surrogate air pollutant. The *AO-regen-seeded* reactor appears to achieve a slightly higher percent removal under most loading conditions than the *air-regen-seeded* system. A maximum removal efficiency of 97% was achieved by the *AO-regen-seeded* biofilter under nominal conditions consisting of a retention time of 148 seconds and a influent concentration of 135 ppm MIBK. On the other hand, the maximum removal rate obtained for the *AO-regen-seeded* was $43 \text{ g/m}^3\cdot\text{hr}$ under nominal conditions consisting of a retention time of 11 seconds and a influent concentration of 115 ppm MIBK. For the *air-regen-seeded* biofilter system, the maximum removal efficiency was 93%, and the maximum removal rate was $44 \text{ g/m}^3\cdot\text{hr}$.

Seeding the sequentially loaded and regenerated GAC biofilter with filamentous microorganisms from the field and adding a mineral salts solution was found to improve performance over a *air-regen-unseeded* GAC biofilter with chlorinated solution addition. The ozone regeneration of the system was found to significantly reduce the pH but not effect the overall performance.

The detention time within the GAC biofilter has a larger effect on the efficiency of the biofilter to remove contaminants from the waste air stream than the contaminant concentration. This experimental behavior is in conformance with mathematically modeled behavior for biokinetics in the first order reaction zone, as was explained herein. A four fold increase in detention time, from 11 seconds to 44 seconds, led to a doubling of the removal efficiency, 18% to 45% for the seeded *air-regen-seeded* and 23% to 41% for the *AO-regen-seeded*. However, a three and a half fold decrease in influent concentration, from 140 ppm to 40 ppm, led to little change in the GAC biofilter removal efficiency, 45% to 44% for the seeded *air-regen-seeded* and 41% to 51% for the *AO-regen-seeded* biofilter.

The effluent concentration was found to be essentially constant over 24 hour cycle of loading and regeneration from the *air-regen-seeded* biofilter and this condition produced a pseudo-steady state air phase concentration within the biofilter at all times. The *AO-regen-seeded* biofilter was found to behave in a similar manner, even though earlier studies by the authors [Dusenbury and Cannon 1996, Cannon *et al* 1996] had found ozonation of a GAC bed to enhance desorption of VOCs. Reductions in influent

mass loading was found to cause desorption of MIBK from the GAC in the biofilters.

This resulted in a negative removal efficiency for approximately one week.

A fed-batch technique was developed to determine kinetic parameters for biofilter material consisting of a biofilm supported on a GAC matrix that degraded MIBK supplied to the biofilm from the air-phase. CO₂ concentration was measured as a function of time and produced a linear fit with coefficients of determination (R²) of 0.90 to 0.998 for all but one set of values and R² of 0.81 for this last set. The slopes of these lines were used to determine generation rates which were plotted versus MIBK air-phase concentration. This resulted in a plot which could be modeled using the Haldane-Andrews kinetics. A best fit analysis was conducted that produced the following kinetic parameters for CO₂ generation $k_{\max} = 250 \text{ ppm CO}_2/\text{HR} \cdot \text{g Biofilter Material}$, $K_s = 675 \text{ ppm MIBK}$, and $K_i = 7040 \text{ ppm MIBK}$. A linear regression of the data within the first order reaction region was performed to obtain a first order rate constant of $k_1 = 0.24 \text{ hr}^{-1}(\text{g biofilter material})^{-1}$. The CO₂ generation rates were then used to estimate MIBK degradation rates resulting in the following degradation kinetic parameters $k_{\max} = 25 \text{ ppm MIBK}/\text{HR} \cdot \text{g Biofilter Material}$, $K_s = 675 \text{ ppm MIBK}$, $K_i = 7040 \text{ ppm MIBK}$, and $k_1 = 0.024 \text{ hr}^{-1}(\text{g biofilter material})^{-1}$.

The data for the *air-regen-seeded* biofilter was well described by the model of Ottengraf [1984] using the kinetic parameters developed via the fed-batch technique. The *AO-regen-seeded* biofilter showed a slight dependence on the influent concentration which was not predicted by the model, perhaps an indication of a phenomena of advanced

oxidation regeneration not accounted for by the model. However, in general the trend for the removal efficiency of the ozonated GAC biofilter may be predicted by the model.

For MIBK, advanced oxidant desorption/destruction was the most pronounced within the first inch of the GAC bed. Advanced oxidant regeneration achieved a maximum desorption/ destruction efficiency of 85% at the influent face of the GAC bed and dropped rapidly to 20% at 3-inches. The remaining 3 inches of the bed continued to achieve 20% regeneration in a 24 hour run. Roughly 10% of the MIBK was converted to products that contained fewer carbon atoms and more oxygen functional groups.

Intriguingly, this study has also demonstrated that when VOCs were removed from GAC surfaces in the presence of advanced oxidants, more VOC mass was removed at a given temperature than when the same VOCs were removed by mild heating to the same temperatures in a humid air environment that contained no advanced oxidants. This suggests that the advanced oxidants were creating a zone within the GAC bed in which adsorption was significantly less favorable, which allowed increased desorption and enhanced destruction of the VOCs.

GAC very effectively captured ozone and associated advanced oxidants from an air stream during initial time periods, but penetration of ozone and advanced oxidants increased with time. A bed of GAC 1/8-inch deep was able to remove over 95% of the initial advanced oxidant concentration from an air stream which was passed through the bed in a 30 minute experimental run. After 24 hour run time, 14% of the initial oxidant concentration was able to penetrate through 1/8-inch of GAC. The removal of advanced oxidants from air by GAC was accompanied by a decrease in mass which may have been

attributed to the oxidation of the GAC surface. The ozone and other advanced oxidants caused an increase in the oxygen content within the GAC, presumably attributed to oxygen functional groups that were created on the GAC surfaces. The ozone and advanced oxidants further caused gasification of the GAC at ambient temperatures.

6.2 CONCLUSIONS

- 1) A sequentially loaded and regenerated GAC biofilter can achieve greater than 95% removal efficiency of MIBK from a simulated humid waste air stream laden with VOC.
- 2) The *air-regenerated-seeded* GAC biofilter performance was strongly dependent on flow rate and independent of influent concentration as predicted by the first order kinetics model developed by Ottengraf [1981]. The *AO-regenerated-seeded* GAC biofilter performance was also strongly dependent on flow rate but furthermore appeared weakly dependent on influent concentration.
- 3) Sequentially loaded and regenerated biofilters seeded with filamentous organisms from a field site performed better than an unseeded GAC biofilter.
- 4) A fed-batch reactor method was developed which was used to determine biological degradation kinetic parameters for a biofilm supported on a adsorbent material via measurement of CO₂ concentration versus time.
- 5) The microbial community present in the seeded sequentially loaded and regenerated GAC biofilters could be represented by Haldane-Andrews type kinetics with

the following kinetic parameters for biodegradation of MIBK: $k_{\max} = 25$ ppm

MIBK/HR*g Biofilter Material, $K_s = 675$ ppm MIBK, and $K_i = 7040$ ppm MIBK.

- 6) GAC was an extremely efficient scavenger of ozone and advanced oxidants from a humid oxidant laden air stream. Dry GAC removed ~100% of the initial ozone in 3-inch deep GAC bed. Ozone was better able to penetrate wet GAC however, the GAC still removed 75% of the initial ozone in a 3-inch deep GAC bed.
- 7) Advanced oxidation regeneration of a MIBK saturated GAC bed removed 85% of the VOC from the influent face of the GAC bed after 24 hours. The removal dropped rapidly to 20% at 3-inches. The remaining 3-inches of the bed continued to achieve 20% removal which was equivalent to warm air desorption.
- 8) Only approximately 10% of the MIBK desorbed from the GAC bed during 24 hour advanced oxidation regeneration was degraded. The majority of the degradation was to shorter chain VOCs and more oxygenated compounds.

6.3 ORIGINAL CONTRIBUTIONS TO SCIENCE AND ENGINEERING

The author proposes that his original contributions to science and engineering via the work herein were:

- 1) An engineering analysis of the Terr-Aqua Environmental Systems Air Pollution Control System which determined that the primary method of treatment in the GAC beds was biofiltration enhanced by ozone/advanced oxidant regeneration.

- 2) The determination that GAC was an extremely effective scavenger of ozone and advanced oxidants and a quantification of the ability of these oxidants to penetrate a bed consisting of virgin GAC or VOC laden GAC.
- 3) Investigation of a sequentially loaded and regenerated GAC biofilter system that showed that ozone regeneration enhanced treatment efficiency when compared to air regeneration and an evaluation of current modeling techniques to show they were applicable to this system.
- 4) Development of a method to determine air-phase kinetic parameters for biofilms supported on adsorbent materials.

REFERENCES:

- 1) Altshuler A.P., "Lifetimes of Organic Molecules in the Troposphere and Lower Stratosphere," Advances in Environmental Science and Technology: Volume 10, J.N. Pitts, R.L. Metcalf, and D. Groshean, (Eds), (New York, NY, John Wiley and Sons, Inc, 1980).
- 2) American Public Health Association, American Water Works Association, and Water Pollution Control Federation, Standard Methods for the Examination of Water and Wastewater, Greenberg, A.E., Trussel, R.R., and Clesceri, L.S. (Eds), American Public Health Association, Washington, DC, 1992.
- 3) ASTM (American Society for Testing of Material) Annual Book of ASTM Standards, American Society for Testing of Materials, Philadelphia, PA., 1988.
- 4) Atkinson R., *Chemical Review*, 85:69-201, 1985.
- 5) Atkinson R. and Carter, W.P.L., *Chemical Review*, 84:437-470, 1984.
- 6) Atyaksheva L.F. and Emel'yanova, G. I, *Russian Journal of Physical Chemistry*, 63:1432-1434, 1989.
- 7) Arvin E., "Biodegradation Kinetics of Chlorinated Aliphatic Hydrocarbons with Methane Oxidizing Bacteria in an Aerobic Fixed Biofilm Reactor," *Water Research*, 25(7):873-881, 1991.
- 8) Arvin E., Jensen, B.K., and Gundersen, A.T., "Biodegradation of Phenols in an Aerobic Biofilm at Low Concentrations," *Water Science and Technology*, 23:1375-1384, 1991.
- 9) Barker S.S., and Jones A.R., "Treatment of Malodorants in Air by the UV/Ozone Technique," *Ozone Science and Engineering*, 10: 405-418 (1988).
- 10) Barton S.S., and Harrison B.H., "Acidic Surface Oxide Structures on Carbon and Graphite-I," *Carbon*, 13: 283-288 (1975).
- 11) Bohn H.L., "Consider Biofiltration for Decontaminating Gases," *Chemical Engineering Progress*, April 1992.
- 12) Bohn H.L. and Bohn R.K., "Soil Bed Scrubbing of Fugitive Gas Releases," *Journal Environmental Health*, A21(6):561-569, 1986.
- 13) Cannon F.S., "Reaction Mechanism of Calcium-Catalyzed Thermal Regeneration of Spent Granular Activated Carbon," Ph.D. Thesis, University of Illinois, 1992.
- 14) Cannon F.S., Dusenbury J.S., Paulsen P.D., Singh J., Mazyck D.W., and Maurer D.J., "Advanced Oxidant Regeneration of Granular Activated Carbon for Controlling Air-phase VOCs," *Ozone Science and Engineering*, 18:417-441, 1996.
- 15) Cannon F.S., Knappe D.R.U., Snoeyink V.L., Lee R.G., Dagois G., and DeWolfe J., "The Effect of Metals Thermal Regeneration of Granular Activated

- Carbon," American Water Works Association Research Foundation (1994).
- 16) Cannon F.S., Snoeyink V.L., Lee R.G., and Dagois G., "Reaction Mechanism of Calcium-Catalyzed Thermal Regeneration of Spent Granular Activated Carbon," *Carbon* 32:7:1285-1301 (1994).
 - 17) Cannon F.S., Snoeyink V.L., Lee R.G., Dagois G., and DeWolfe J., "The Effect of Calcium in Field-Spent Granular Activated Carbons on Pore Development During Thermal Regeneration," *Journal of the American Water Works Association*, Mar 76-89 (1993).
 - 18) Cao, Y.S. and Alaerts, G.J., "Influence of Reactor type and Shear Stress on Aerobic Biofilm Morphology, Population and Kinetics," *Water Research*, 29(1):107-118, 1995.
 - 19) Cleasby, "Filtration," Water Quality and Treatment: A Handbook of Community Water Supplies, H.B Crawford (Ed), (New York, NY, McGraw-Hill, 1990).
 - 20) Cox R.A., Derwent R.G., and Williams M.R., "Atmospheric Photooxidation Reactions: Rates, Reactivity, and Mechanism for Reaction of Organic Compounds with Hydroxyl Radicals," *Environmental Science and Technology*, 14:57-61 (1980).
 - 21) Cox R.A., Patrick K.F., and Chant S.A., "Mechanism of Atmospheric Photooxidation of Organic Compounds. Reactions of Alkoxy Radicals in Oxidation of n-butane and Simple Ketones." *Environmental Science and Technology*, 15:587-592 (1981).
 - 22) Deitz V.R., and Bitner J.L., "The Reaction of Ozone with Adsorbent Charcoal," *Carbon*, 10:145-154 (1972).
 - 23) Deitz V.R., and Bitner J.L., "Interaction of Ozone with Adsorbent Charcoal," *Carbon*, 11:393-401 (1973).
 - 24) Deshusses M.A., Hamer G., and Dunn I.J., "Behavior of Biofilters for Waste Air Biotreatment. 1. Dynamic Model Development," *Environmental Science and Technology*, 29:1048-1058, 1995.
 - 25) Deshusses M.A., Hamer G., and Dunn I.J., "Behavior of Biofilters for Waste Air Biotreatment. 2. Experimental Evaluation of a Dynamic Model," *Environmental Science and Technology*, 29:1059-1068, 1995.
 - 26) Devinsky J.S. and Hodge D.S., "Formation of Acidic and Toxic Intermediates on Overloaded Ethanol Biofilters," *Journal of the Air and Waste Management Association*, 45:125-131, 1995.
 - 27) Diks R.M.M. and Ottengraf S.P.P., "Verification Studies of a Simplified Model for the Removal of Dichloromethane from Waste Gases Using Biological Trickling Filter (Part I)," *Bioprocess Engineering*, 6:93-99, 1991.
 - 28) Dilling W.L., Bredeweg C.J., and Tefertiller N.B., "Organic Photochemistry: Simulated Atmospheric Photodecomposition Rates of Methylene Chloride, 1,1,1-Trichloroethane, Trichloroethylene, Tetrachloroethylene, and Other Compounds," *Environmental Science and Technology*, 10:351-356 (1976).

- 29) Dusenbury, J.S., and Cannon F.S., *Proceedings of the 22nd Biennial Conference on Carbon*, July 16-21, San Diego, CA, 1995
- 30) Dusenbury J.S. and Cannon F.S., "Advanced Oxidant Reactivity Pertaining to Granular Activated Carbon Beds for Air Pollution Control," *Carbon*, 34(12):1577-1589, 1996.
- 31) Dubinin M.M., "Porous Structure and Adsorption Properties of Active Carbons," *Chemistry and Physics of Carbon*, vol.2, p. 51-120 (1966).
- 32) Ellis W.D., and Tometz, P.V., *Atmospheric Environment*, 6:707-714, 1972
- 33) Fendel, W., Matter, D., Burtscher, H., and Schmidt-Ott, A., *Atmospheric Environment*, 29:967-973, 1995.
- 34) Finlayson-Pitts and Pitts, *Atmospheric Chemistry*, 1986
- 35) Fox P. and Suidan M.T., "A Fed-Batch Technique to Evaluate Biodegradation of Inhibitory Compounds with Anaerobic Biofilms Attached to Granular Activated Carbon," *Water Science and Technology*, 23:1337-1346, 1991.
- 36) Gay B.W., Hanst P.L., Bufalini J.J., and Noonan R.C., "Atmospheric Oxidation of Chlorinated Ethylenes," *Environmental Science and Technology*, 10:58-67 (1976).
- 37) Glaze W.H., Kang, J.W., and Chapin, D.H., *Ozone Science and Engineering*, 9:335-352, 1987.
- 38) Glaze W.H., Lin C-C., Crittenden J.C., and Cotton R., "Adsorption and Microbial Mechanisms for Removal of Natural Organics in Granular Activated Carbon Columns," *Ozone Science and Engineering*, 8:299-319, 1986.
- 39) Grady C.P.L., Dang J.S., Harvey D.M., Jobbagy A., and Wang X.-L., "Determination of Biodegradation Kinetics Through the Use of Electrolytic Respirometry," *Water Science and Technology*, 21:957-968, 1989.
- 40) Gonenc I.E., Orhon D., and Beler Baykal, B., "Application of Biofilm Kinetics to Anaerobic Fixed Bed Reactors," *Water Science and Technology*, 23:1319-1326, 1991.
- 41) Gregg S.J., and Sing K.S.W., *Adsorption, Surface Area and Porosity*, (London and New York, Academic Press, 1982).
- 42) Harremoes P., "The Significance of Pore Diffusion to Filter Denitrification," *Journal Water Pollution Control Federation*, 48(2):377-388, 1976.
- 43) Hassler J.W., *Purification with Activated Carbon, Industrial, Commercial, Environmental*, (New York, NY, Chemical Publishing Company, 1974)
- 44) Heath M.S., Wirtel S.A., and Rittmann B.E., "Simplified Design of Biofilm Processes Using Normalized Loading Curves," *Research Journal Water Pollution Control Federation*, 62(2):185-192, 1990
- 45) Heath M.S., Wirtel S.A., and Rittmann B.E., "To Discussion of: Simplified Design of Biofilm Processes Using Normalized Loading Curves," *Research Journal Water Pollution Control Federation*, 63(1):91-92, 1991.
- 46) Heinsohn R.J., and Kabel R.L., *Sources and Control of Air Pollution*, The Pennsylvania State University, University Park, PA, 1995

- 47) Hermann G., and Huttinger K.J., "Mechanism of Iron-Catalyzed Water Vapour Gasification of Carbon," *Carbon* 24:4:429-435 1986.
- 48) Hodge D.S. and Deviny J.S., "Biofilter Treatment of Ethanol Vapors," *Environmental Progress*, 13(3):167-173, 1994.
- 49) Hodge D.S., Medina V.F., Islander R.L., and Deviny J.S., "Treatment of Hydrocarbon Fuel Vapors in Biofilters," *Environmental Technology*, 12:655-662, 1991.
- 50) Hurt R.H., Sarofim A.F., and Longwell J.P., "Role of Microporous Surface Area in Uncatalyzed Carbon Gasification," *Energy and Fuels*, 5:290-299 1991.
- 51) Hurt R.H., Sarofim A.F., and Longwell J.P., "Role of Microporous Surface Area in the Gasification of Chars from a Sub-bituminous Coal," *Fuel*, 70:1079-1082.
- 52) Huang C. P., Dong C., and Tang T., *Waste Management*, 13:361-377, 1993.
- 53) Ingold C.T. and Hudson H.J., The Biology of Fungi, Chapman and Hall, London, UK, 1993.
- 54) Kampbell D.H., Wilson J.T., Read H.W., and Stocksdales T.T., "Removal of Volatile Aliphatic Hydrocarbons in a Soil Bioreactor," *Journal of the Air Pollution Control Association*, 37(10):1236-1240.
- 55) Kirchner K., Kramer P., and Rehm H.-J., "Adsorption and oxidation of pollutants using bacterial cultures (monocultures)," *International Chemical Engineering*, 25(3):428-435, 1985.
- 56) La Cour Jansen J. And Poul Harremoes P., "Removal of Soluble Substrates in Fixed Films," *Water Science and Technology*, 17:1-14, 1984.
- 57) Leahy M.C. and Brown R.A., "Bioremediation: Optimizing Results," *Chemical Engineering*, May 1994.
- 58) Leson G. and Winer A.M., "Biofiltration: An Innovative Air Pollution Control Technology for VOC Emissions," *Journal Air Waste Management Association*, 41(8):1045-1054, 1991.
- 59) Lyman W.J., Reehl W.F., and Rosenblatt D.H., Handbook of Chemical Property Estimation Methods, American Chemical Society, Washington, DC., 1990.
- 60) Martinez R.I., Herron J.T., and Huie R.E., *Journal of the American Chemical Society*, 103:3807-3820, 1981.
- 61) Mattson J.S. and Mark H.B., Jr., Activated Carbon, Surface Chemistry and Adsorption from Solution, M. Dekker, New York, NY, 1972.
- 62) Metcalf and Eddy Wastewater Engineering, Treatment, Disposal, Reuse, Tchobanoglous G. and Burton F.L. (Eds), McGraw-Hill, New York, NY, 1991.
- 63) Notthakun S., Crittenden J.C., Hand D. W., Perram D.L., and Mullins M.E., *Journal of Environmental Engineering*, 119:4:695-714, 1993.
- 64) Ottengraf S.P.P., "Exhaust Gas Purification," Biotechnology, vol 8 VCH Verlagsgesellschaft Weinheim, Rehm H.J., and Reed G, (Eds), 1981.

- 65) Ottengraf S.P.P. and Van Den Oever A.H.C., "Kinetics of Organic compound Removal from Waste Gases with a Biological Filter," *Biotechnology and Bioengineering*, 26:3089-3102, 1983
- 66) Overcamp T.J., Chang H-C, and Grady C.P.L., "An Integrated Theory for Suspended Growth Bioscrubbers," *Journal of the Air and Waste Management Association*, 43:753-759, 1993.
- 67) Proceedings of a Symposium on Activated Carbon, Manufacture, Properties, Evaluation, Applications, Presented by Atlas Chemical Industries, Inc., Wilimington, Del, 1968.
- 68) Prokop W.H. and Bohn H.L., "Soil Bed System for Control of Rendering Plant Odors," *Journal of the Air Pollution Control Association*, 35(12):1332-1338, 1985.
- 69) Shah J.J., and Singh H.B., "Distribution of Volatile Organic Chemicals in Outdoor and Indoor Air," *Environmental Science and Technology*, 22:1381-1388 (1988).
- 70) Shareefdeen Z., Baltzis B.C., Oh Y-S., and Bartha R., "Biofiltration of Methanol Vapor," *Biotechnical Bioengineering*, 41(5):512-524, 1993.
- 71) Singh J., Master's Thesis, Pennsylvania State University, (1995).
- 72) Singh J. and Cannon F.S., "Characterization of GACs Regenerated Using Advanced Oxidation Processes," ASCE, Environmental engineering Division, National Conference, Pittsburgh, PA, August, (1995).
- 73) Singh H.B., and Zimmerman P.B., "Atmospheric Distribution and Sources of Nonmethane Hydrocarbons," Gaseous Pollutants: Characterization and Cycling, J.O. Nriagu, (Ed), John Wiley and Sons, Inc., New York, NY, 1992.
- 74) Smith J.M., Chemical Engineering Kinetics, McGraw-Hill, New York, NY, 1981.
- 75) Snoeyink V.L., "Adsorption of Organic Compounds," Water Quality and Treatment: A Handbook of Community Water Supplies, H.B Crawford (Ed), McGraw-Hill, New York, NY, 1990.
- 76) Stephens, S., Rossi, M.J., and Golden, *International Journal of Chemical Kinetics*, 18:1133-1149, 1986.
- 77) Takeuchi, Y. and Itoh, T, *Separation Technology*, 3:168-175, 1993.
- 78) Tang H-M, Hwang S-J, and Hwang S-C, "Waste Gas Treatment in Biofilters," *Journal Air and Waste Management Association*, 46:249-354, 1996.
- 79) Tien M. and Meyer, S.B., Selection and Characterization of Mutants of *Phanerochaete chrysosporium* Exhibiting Ligninolytic Activity under Nutrient-Rich Condition," *Applied and Environmental Microbiology*, 56(8):2540-2544, 1990.
- 80) Utgikar V., Govind R., Shan Y., Safferman S., and Brenner R.C., "Biodegradation of Volatile Organic Chemicals in a Biofilter," Emerging Technologies in Hazardous Waste Management II: ACS Symposium Series, Tedder D.W. and Pohland F.G. (Eds), American Chemical Society, Washington, DC, 1991.

- 81) Verschueren, K. Handbook of Environmental Data on Organic Chemicals, Van Nostrand Reinhold, New York, NY, 1996.
- 82) Voice T.C., Pak D., Zhao X., Shi J., and Hickey R.F., "Biological Activated Carbon in Fluidized Bed Reactors for the Treatment of Groundwater Contaminated with Volatile Aromatic Hydrocarbons," *Water Research*, 26(10):1389-1401, 1992.
- 83) Walker P.L., "Activated Diffusion of Gases in Molecular-Sieve Materials," *Chemistry and Physics of Carbon*, vol.2 1966.
- 84) Wark K. and Warner C.F., Air Pollution: Its Origin and Control, HarperCollins, Publishers, Inc. NY, NY, 1981.
- 85) Young J.C., Garner W., and Clark J.W., "An Improved Apparatus for Biochemical Oxygen Demand," *Analytical Chemistry*, 37:784, 1965.
- 86) Young J.C. and Baumann E.R., "The Electrolytic Respirometer - I, Factors Affecting Oxygen Uptake Measurements," *Water Research*, 10:1031-1040, 1976.

**APPENDIX
LIST OF SYMBOLS**

$A =$	cross-sectional area (m^2)
$a =$	interfacial area per unit volume ($m^2 m^{-3}$)
$C =$	concentration of growth-limiting substrate, (mass/ unit volume) C_L and $C_G =$ concentrations in the liquid(biofilm) and gas phases respectively.
$D =$	diffusional coefficient of the VOC in the biofilm ($m^2 hr^{-1}$)
$H_s =$	Henry's constant
$K_1 =$	reaction unit $[(a/\delta)D_e\phi_1 \tanh\phi_1]$
$k_{1,a} =$	1st order rate constant ($m hr^{-1}$)
$k_{1/2,a} =$	1/2 order rate constant ($mg^x m^{-x} hr^{-1}$)
$k_{0,a} =$	0 order rate constant ($mg m^{-2} hr^{-1}$)
$k_{1,f} =$	first order intrinsic reaction rate in the biofilm (hr^{-1})
$K_i =$	inhibition coefficient (ppm)
$k_m =$	maximum substrate utilization rate ($mg m^{-3} hr^{-1}$)
$k_{max} =$	apparent rate constant normalized on a per gram of biofilter material basis
$K_s =$	half-velocity constant, substrate concentration at one-half the maximum growth rate, (mass/ unit volume)
$m_s =$	distribution coefficient of the substrate (dimensionless Henry's constant)
$\mu =$	specific growth rate ($time^{-1}$)
$\mu_{max} =$	maximum specific growth rate ($time^{-1}$)

$P =$	product concentration (mass/unit volume)
$p_s =$	partial pressure of the substrate (Pa)
$Q_G =$	volumetric flow rate (m^3/s)
$R =$	universal gas constant per mole
$r_{1,a}, r_{1/2,a},$ and $r_{0,a} =$	1st, 1/2, and 0 order surface removal rates ($mg\ m^{-2}hr^{-1}$)
$r_g =$	rate of bacterial growth (mass/unit volume*t)
$r_s =$	$-(r_g/Y)$ (mass/unit volume*t)
$T =$	temperature (K)
$U_G =$	average gas velocity, $U_G = Q_G/A$
$X =$	biomass concentration (mg cells/unit volume)
$x =$	penetration into the biofilm layer (m)
$Y_b =$	biomass yield (mg cells/mg substrate)
$Y_p =$	product yield
$z =$	height of the biofilter (m)
$\delta =$	biofilm thickness (m)
$\epsilon =$	efficiency factor
$\lambda =$	penetration thickness $\lambda = \sqrt{\frac{2D_e c_G(z)}{k_0 m_s}}$
$\phi =$	$\delta (k/D_e c)^{1/2}$ (Theile number)
$\sigma =$	x/δ is the dimensionless length coordinate in the biolayer.

JAMES SAYE DUSENBURY

EDUCATION: **The Pennsylvania State University, University Park, Pennsylvania**
Ph.D., Environmental Engineering, GPA: 4.0/4.0 Summer 1997
Thesis: *Ultra-Violet Light/Ozone Treatment of an Air-Phase Granular Activated Carbon Biofilter*
M.S., Environmental Engineering, GPA: 3.9/4.0 Spring 1994
Thesis: *Super Absorbent Polymers for the Removal of Aqueous Solutions from Hydrocarbons*
Worcester Polytechnic Institute, Worcester, Massachusetts
B.S., Chemical Engineering Spring 1988
Thesis: *Trickling Filter Pre-treatment for Slow Sand Filtration and the Impact of Cold Weather*
Engineer-in-Training Certified: Passed the Fundamentals of Engineering Exam
Fall 1993

EXPERIENCE: **Technical Skills:**
* Designed, constructed, operated, and sampled bench and pilot-scale systems for the evaluation of ultra-violet light/ozone treatment of a granular activated carbon biofilter which achieved >95% removal.
* Skilled in the operation and data analysis of the gas chromatograph/mass spectrophotometer, atomic absorption spectrophotometer, and total organic carbon analysis.
Management Skills:
* Maintained 196 pieces of equipment including vehicles, generators, and communications devices at or above an operational status of 94%.
* Managed a \$100,000 repair part budget to one tenth of one percent.
* Trained and directed a 28 soldier platoon in the acquisition, storage and issue of supplies and equipment for a 1500 soldier brigade.
* Created and implemented a security and inspection program for a 193 soldier battalion.
Communication Skills:
* Presented formal quarterly technical progress reports.
* Planned, coordinated, and directed the deployment and performance of a 19 soldier support slice for a major training exercise in California.

WORK HISTORY
Research Assistant, Penn State University, University Park, PA 6/93 - 6/97
United States Army - First Lieutenant 9/88 - 6/92
Security/Operations Officer, Ft Drum, NY 11/90 - 6/92
Battalion Maintenance Officer, Ft Drum, NY 3/90 - 11/90
Platoon Leader, Ft Drum, NY 3/89 - 3/90

PUBLICATIONS DUSENBURY, J.S. & CANNON, F.S., "Advanced Oxidant
PRESENTATIONS Reactivity Within Granular Activated Carbon Beds for Air
Pollution Control," *Carbon*, 34(12):1577-1589, 1996.
DUSENBURY, J.S. & CANNON, F.S., "Granular Activated Carbon Regeneration
with Advanced Oxidants to Control VOCs," Presented at the 22nd Biennial
Conference on Carbon, July 16-21, San Diego, CA, 1995.
CANNON, F.S., DUSENBURY, J.S., PAULSEN, P.D., SINGH, J., MAZYCK,
D.W., AND MAURER, D.J., "Advanced Oxidant Regeneration of Granular
Activated Carbon for Controlling Air-phase VOCs," *Ozone Science and
Engineering*, 18(5): 417-441 1996.