

265272

JPRS 81474

6 August 1982

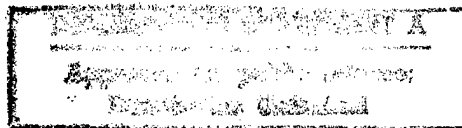

USSR Report

CONSTRUCTION AND EQUIPMENT

No. 71

19980914 114

FBIS

FOREIGN BROADCAST INFORMATION SERVICE

REPRODUCED BY
NATIONAL TECHNICAL
INFORMATION SERVICE
U.S. DEPARTMENT OF COMMERCE
SPRINGFIELD, VA. 22161

7
42
A03

NOTE

JPRS publications contain information primarily from foreign newspapers, periodicals and books, but also from news agency transmissions and broadcasts. Materials from foreign-language sources are translated; those from English-language sources are transcribed or reprinted, with the original phrasing and other characteristics retained.

Headlines, editorial reports, and material enclosed in brackets [] are supplied by JPRS. Processing indicators such as [Text] or [Excerpt] in the first line of each item, or following the last line of a brief, indicate how the original information was processed. Where no processing indicator is given, the information was summarized or extracted.

Unfamiliar names rendered phonetically or transliterated are enclosed in parentheses. Words or names preceded by a question mark and enclosed in parentheses were not clear in the original but have been supplied as appropriate in context. Other unattributed parenthetical notes within the body of an item originate with the source. Times within items are as given by source.

The contents of this publication in no way represent the policies, views or attitudes of the U.S. Government.

PROCUREMENT OF PUBLICATIONS

JPRS publications may be ordered from the National Technical Information Service (NTIS), Springfield, Virginia 22161. In ordering, it is recommended that the JPRS number, title, date and author, if applicable, of publication be cited.

Current JPRS publications are announced in Government Reports Announcements issued semimonthly by the NTIS, and are listed in the Monthly Catalog of U.S. Government Publications issued by the Superintendent of Documents, U.S. Government Printing Office, Washington, D.C. 20402.

Correspondence pertaining to matters other than procurement may be addressed to Joint Publications Research Service, 1000 North Glebe Road, Arlington, Virginia 22201.

Soviet books and journal articles displaying a copyright notice are reproduced and sold by NTIS with permission of the copyright agency of the Soviet Union. Permission for further reproduction must be obtained from copyright owner.

USSR REPORT
CONSTRUCTION AND EQUIPMENT

No. 71

CONTENTS

CONSTRUCTION

'PRAVDA' Hits Neglect on New Construction Method (Editorial Report).....	1
Construction Minister on Clients' Shortcomings (Editorial Report).....	1

BUILDING MATERIALS

New Wholesale Prices for Cement Intended To Be More Adaptable (V. S. Karelin, et al.; TSEMENT, Apr 82).....	2
New Kilns for Dry-Process Cement Production Described (V. N. Lyamin, P. L. Tikhomirov; TSEMENT, May 82).....	11

METALWORKING EQUIPMENT

Development of Industrial Robot Production During 1981-1985 (V. Lebedev; PLANOVOYE KHOZYAYSTVO, Jun 82).....	19
Robotics: Applications, Developments (Various sources, various dates).....	25
General-Purpose Robot Principles, Applications of Robotics, by Kh. Tlysmus Courses in Robotics Training, by N. Petrov Manipulator Drives, by V. D. Darovskikh	
Renovation Slow at Makinsk Piston Ring Plant (M. V. Stepanov; NARODNOYE KHOZYAYSTVO KAZAKHSTANA, Feb 82).....	33
Renovation at Volgograd Hardware Plant (A. I. Belov, et al.; MASHINOSTROITEL', Mar 82).....	36

CONSTRUCTION

'PRAVDA' HITS NEGLECT ON NEW CONSTRUCTION METHOD

PML20727 [Editorial Report] Moscow PRAVDA in Russian 17 June 1982 carries on page 3 a 1,900-word article entitled "Not Their Field; the Fortunes of an Invention" by V. Goncharov criticizing delays in testing and introducing an "unusual and original" new construction method--the "elevation method" [metod vydvizheniya]--invented by A. Z. Pruzhinin, laboratory chief at the Moscow's Kuybyshev Construction Engineering Institute Scientific Research Institute for Construction Organization and Administration. The author accuses the USSR Ministry of Procurement, and Deputy Minister K. Kuznetsov in particular, of losing interest in the project after allocating funds for its development and the research institute of "stifling" it while at the same time continuing to use funds allocated for it for other purposes. Construction trusts' fear that the reduction in the cost of construction and installation work which the introduction of the new method would yield would adversely affect their labor productivity indicators and wages is identified as a factor in the failure of the invention to make an impact in the industry. The article concludes by recommending that the matter be taken in hand by the USSR Gosstroy in collaboration with the USSR Ministry of Procurement and the USSR Ministry of Higher and Secondary Specialized Education.

CONSTRUCTION MINISTER ON CLIENTS' SHORTCOMINGS

PML20743 [Editorial Report] Moscow PRAVDA in Russian 23 June 1982 publishes on page 2 under the headline "The Customer and the Construction Project" a 2,000-word article by Hero of Socialist Labor B. Bakin, USSR minister of installation and special construction work, discussing from the installation workers' viewpoint the problems arising in the construction industry as a result of "poor management" on the part of the "customer"--usually a sector ministry--which orders new installations but then fails to provide sufficient finance and equipment to complete the work within the planned time limits. The minister recommends better planning and stricter control of execution of orders and a more responsible attitude on the part of "customers" in order to overcome shortcomings.

CSO: 1821/162

BUILDING MATERIALS

UDC 666.940:338.585

NEW WHOLESALE PRICES FOR CEMENT INTENDED TO BE MORE ADAPTABLE

Moscow TSEMENT in Russian No 4, Apr 82 (signed to press 26 Mar 82) pp 1-4

[Article by Candidates of Economic Sciences V. S. Karelin and F. A. Tseytlin and Engineer V. G. Dubravina (NIITsement [State All-Union Scientific-Research Institute of the Cement Industry]): "The New Wholesale Prices for Cement"]

[Text] "The Main Directions for the Economic and Social Development of the USSR During 1981-1985 and During the Period Prior to 1990" posed the goals of improving price-setting in the national economy's branches as an important tool for plan management; of intensifying the stimulating influence of wholesale prices on improvement in the quality of manufactures, acceleration of the assimilation of new and highly effective equipment, the replacement of obsolete equipment, the more rational use of production resources, and reduction in the cost of output; and of strengthening state price discipline.

The new wholesale prices for cement were approved in 1981.

The main purpose of the revision in wholesale prices was to intensify their stimulating effect on scientific and technical progress, save fuel-and-power resources, raw materials and other materials, raise the quality of cement, and cause prices to reflect more fully the socially necessary expenditures for producing output.

The previously effective prices for cement were introduced on 1 July 1967, but since then they have become quite obsolete. They do not reflect the changes that have occurred in the production structure of this binding agent, and the siting of enterprises does not correspond with the modern circumstances of production and sale of the output.

In recent years the production share of the enterprises of the country's eastern regions has been greatly increased, the geological conditions for quarrying carbonate and clayey rocks have worsened for a number of operating enterprises, expenditures for protecting the environment have increased, and norms for the amortization and capital-intensiveness of production facilities have increased. Moreover, major steps to regularize pay for the industry's workers have been taken.

As a result of this, despite steps taken to raise the technical level, the profitability of cement production fell from 27.7 percent in 1975 to 18.7 percent in 1980 in relation to prime production costs and from 10.6 percent to 6.7 percent in relation to the average annual cost of productive capital.

While in 1975 there were 2 unprofitable enterprises (the Checheno-Ingushskiy and Karachayevo-Cherkesskiy Cement Plants) in the industry, in 1980 their number reached 11 (the Shchurovskiy, Checheno-Ingushskiy, Karachayevo-Cherkesskiy, Magnitogorsk, Kamenets-Podol'sk, Bekabad, Navoy, Karaganda, Karadag, Kurmentinskiy and Kosogorskiy plants), and some enterprises were on the verge of unprofitable operation (the Bryansktsement and Mordovtsement PO's [production associations] and the Yashkino, Krivoy Rog, Nikolayev and Razdan Cement Plants).

The main causes of the unprofitability of operation of a number of enterprises were the unsatisfactory conduct of production-economics activity, a slow pace in assimilating design capacity, the great distance to quarries, and a worsening of the geological conditions for quarrying the raw material.

At the same time, at some enterprises there was extraordinarily high profitability (more than 40-50 percent of prime production costs), a fact that weakened their motivation to implement a savings regime and to reduce prime production costs (the Savin, Vorkuta, Bezmein, Novotroitskiy, Angara, Timlyuy, Teploozersk, Yakutsk, Sas-Tyubinsk and Tauz Cement Plants).

In the past 15 years definite regional changes have occurred, not only in the siting of production facilities but also in the consumption of cement. Some new cement plants have been built and new large centers of consumption have appeared, especially in remote parts of the country.

All these factors have influenced change in total expenditures for the cement that is shipped to each territorial region, as a result of which actual expenditures for its production and shipment to various oblasts and parts of the country no longer correspond with the established wholesale prices.

Because of these circumstances, a revision of wholesale prices for cement and the introduction of new prices (with simultaneous recomputation of all plan indicators) on 1 January 1982 had become an urgent necessity.

Two pricing handbooks for the cement industry were retained:

wholesale prices for the industry c.i.f. the consignee's railroad yard (Handbook No 06-01); and

wholesale (settlement) prices for enterprises f.o.b. the point of shipment (Handbook No 06-17-46).

The existence of these two handbooks enables profitable cost-accounting operation of most enterprises of the industry at unified wholesale prices.

The wholesale (settlement) price for enterprises includes the full prime production cost of the cement and profit, while the wholesale price for the industry includes, in addition to this, costs for hauling the cement to the points of consumption and expenditures for upkeep of the marketing organ--Soyuzglavtsement [Main Administration for the Supply and Marketing of Cement].

Let us examine the basic components of the wholesale price for cement.

The Prime Production Cost of Cement. Wholesale prices were revised on the basis of the planned prime production cost of cement for 1980, in which adjustments were made that considered:

change in prices and charges for the output of other branches of the economy;

increases in the rates for contributions to social insurance;

increase in (or the introduction of) payment for land;

increase in expenditures linked with the greater distance to quarries, protection of the environment, and so on; and

reduction or increase in the prime production cost while the handbook is in effect.

In past years the cost of cement has tended to increase steadily. The basic reasons for this were: increase in expenditures for protection of the environment; a rise in the norms for amortization deductions; increase in expenditures for the up-keep and operation of equipment by virtue of the rise in the capital-intensiveness of production; the complication of geological conditions for quarrying the raw materials and the increasing distance to the quarries; and a rise in quality and improvement of the products mix (an increase in the share of additive-free cement, the output of high-grade cements, and an increase in the clinker content in cement with mineral additives).

The rise in the branch's average prime production cost for cement is also explained by an increase in the share of cement that is produced at plants where its prime production cost is higher than the branch average. At new and enlarged enterprises the prime production cost of the output is higher than at old plants introduced in the 1950's and 1960's. In comparison with 1970, the prime production cost of 1 ton of cement in 1980 was 15 percent higher, and, taking the increase in average grade (from 38.8 to 40.8 MPa) into consideration, it was 11.5 percent higher.

The effect of the above-enumerated cost-increasing factors will be predominant also during the 11th Five-Year Plan. Therefore, the prime production cost of the cement, which has increased by 3.9 percent (without taking external factors into account--changes in the prices for fuel and power resources and material resources), was made the basis for the prices.

The rise in prices for raw materials, fuel and other materials exerted the most important influence on change in prime production costs. On the average, the prices of fuel consumed by the cement industry have risen by 41.7 percent (49.5 percent for gas, 34.8 percent for mazut, 24.5 percent for coal, and 12.9 percent for shale), while electricity has risen 18.3 percent, granulated slag 76.0 percent, purchased raw materials 20.0 percent, and metals, grinding aids and refractories 10.0-20.0 percent.

The prime production cost of cement also increased because of the rise of the standard for social insurance deductions, from 6.1 to 12.0 percent.

As a result of all these factors, the prime production cost of cement was increased by almost 20 percent, and, taking internal cost-increasing factors into account, by 24 percent.

The greatest increase in the cost of output is expected at the Savin, Bezmein, Angren and Kiev Cement Plants and the Novorostsement Combine because of the use of expensive fuel and slag and other materials that are brought in from afar. At some enterprises that are mastering production capacity (the Bryansktsement, Spassktsement and Karagandatsement plants and the Shchurovskiy and Starooskol Cement Plants), the prime production cost is either being reduced or it will be increased slightly (by 5-10 percent).

An analysis of the new wholesale prices for raw and other materials consumed by the cement industry indicates that, for most of them, their level is economically justified and corresponds with the interests of the national economy.

But this cannot be said about the price for sulfite-yeast mash (SDB), which is widely used in the cement industry as a thinning agent. While it cost 9 rubles per ton at 1968 prices, which enabled its consumption to be doubled in the cement industry in 1970-1980 and more than 1 million tons of standard fuel equivalent to be saved during this period, the new pricing handbook sets its price at 30 rubles per ton, which makes the use of SDB economically unsuitable in the cement industry.

NIItsement calculations indicate that an increase in SDB prices equal to the rise in prices for fuel (by 42 percent), that is, to 12 rubles and 50 kopecks, would enable the use of SDB concentrates to be doubled during the 11th Five-Year Plan and an approximate additional 100,000 tons of standard fuel equivalent to be saved.

Standard Profit and Profitability. Profit for the purpose of calculating standards of profitability were set at a level that will enable normal cost-accounting for the operations of an absolute majority of the industry's enterprises at the time the new wholesale prices were introduced. It envisioned the possibility of creating economic-incentive funds and for forming a single fund for the development of science and technology and for repaying bank credit and for paying interest on it, and the possibilities of providing for growth in working capital, and, in cases of necessity, of financing capital investment. The standard of profitability considered increases in the prime production cost of cement caused by price rises in other industries.

On the average for the cement industry, the standard of profitability has been set at 12.9 percent of the average annual cost of productive capital and of working capital for which norms have been set.

The simultaneous growth of profit and prime production cost led to profitability growing from 18.8 to 29.6 percent for the cement industry as a whole (in percents of prime production cost) as a result of the price revision.

This is caused by a number of factors: a necessity for full elimination of unprofitable enterprises, a leveling of profitability, improvement in the correlation of prices for interchangeable types of cement, and the incentive to produce more progressive and higher quality types of the binding agent, which affect positively an intensification of the processes and a rise in the effectiveness of production, will create the prerequisites for converting the industry to full cost-accounting (including the financing of capital investment through in-house accumulations).

After calculating the prime production cost and total profit (in accordance with standard profitability) of enterprises, the total of the commodity output and

the average wholesale (settlement) price can be calculated. The wholesale prices for individual types and grades of cement were figured on the basis of these data and the established intertype and intergrade price coefficients.

Intertype and Intergrade Price Coefficients. In setting the new wholesale prices (both settlement and zonally differentiated), the developers were guided by intertype and intergrade factors of cement effectiveness for the establishment of the wholesale prices that were approved by USSR Gosstroy in 1978 (table 1).

Table 1

Type of Cement	Price coefficients K_{ts} for cements of the grades		
	300	400	500
Cements for general construction purposes			
Portland cement with mineral additives.....	0.87	1.00	1.165
Portland cement.....	--	1.11	1.290
High early-strength portland cement.....	--	1.08	1.260
Slag portland cement.....	0.75	0.85	0.990
High early-strength slag portland cement.....	--	1.00	--
Sulfate-resistant cement			
Sulfate-resistant portland cement.....	--	1.00	--
Sulfate-resistant portland cement with mineral additives.	--	0.84	1.00
Sulfate-resistant slag portland cement nt [low- temperature].....	0.72	0.85	--
Pozzolan portland cement.....	0.66	0.78	--

The following price coefficients k_{ts} (versus grade 400) have been adopted in prices as incentives to produce high-grade cements: $k_{ts} = 1.35$ for grade 550, and $K_{ts} = 1.60$ for grade 600.

The use of unified coefficients both for settlement prices for enterprises and of zonally differentiated prices c.i.f. the consignee's railroad yard will enable identicalness in the financial results of the operation of the enterprises and of Soyuzglavtsement and completely adequate profitability of the production facility for the main types of cement (except, perhaps, for slag portland cement) to be provided.

The utilization effectiveness coefficient of 400-grade slag portland cement in construction is 0.95 and the price coefficient is 0.85. With this coefficient, the profitability of portland cement production (as a ratio of profit to the prime production cost of the cement) equals 30.4 percent, while for slag portland cement it is only 22.5 percent. For a number of plants that use slag hauled in from comparatively distant places, the production of slag portland cement will become unprofitable. Thus, the designed profitability of slag portland cement at the Sebryakov plant is +5 percent and at the Novorostsement Combine it is -7.5 percent, while at the Bezmein plant it is +7.1 percent. Thus, the prices introduced on 1 January 1981 for customers for slag portland cement will provide high effectiveness for its use in construction, but, for a majority of the producers, comparatively less production effectiveness.

With a view to stimulating slag portland cement production, since it is more effective from the point of view of expenditure of fuel and power resources per unit of useful output, it would be desirable to increase the price factor for slag portland cement from 0.85 to 0.90. This will put slag portland cement and portland cement with mineral additives on an identical level of profitability, and this would be desirable because it would stimulate increased slag portland cement production in amounts that will enable use of the resources of blast-furnace slag and granulated electrothermal phosphorus slag. Retention of the k_{ts} at the 0.85 level will lead to some reduction in profit, which does not correspond with the utilization effectiveness of use of slag portland cement in construction.

The new wholesale-prices handbooks for cement left unresolved the question of establishing temporary markups to existing wholesale prices for new, highly effective output and for output with the State Emblem of Quality.

In 1980 more than 25 percent of the cement made in the country was produced with the Emblem of Quality. Under the new management terms, incentive funds are formed during 1981-1985 through growth in labor productivity and increase in the share of output of products of the highest quality category in total production volume.

At the same time, cements certified for the State Emblem of Quality do not have a price markup, that is, there is an absolute lack of connection between this indicator and growth in profit--the basic source of incentives.

Price markups are now established in accordance with the Instructions on the Procedure for Establishing Incentive Markups to Wholesale Prices for New, Highly Effective Output, where the minimal coefficient of effectiveness (the ratio of the economic benefit to the wholesale price) is 0.15.

But in the cement industry, all types and grades of cement are, practically, unchangeable products. And the appearance of completely new types and grades of cement is an extraordinarily rare phenomenon.

Cement is certified for the highest quality category on the basis of the qualitative indicators of previously produced output, basically by raising the stability of the strength indicators, and also by eliminating the phenomenon of false setting and reducing the temperature of shipped cement, which are extremely important for its customers.

The economic benefit from the use of cement that is certified as being of the highest quality category is occasioned by reduction in the variation coefficient in the cement's activity after 28 days of hardening, which, in its turn, leads to a reduction in cement consumption per cubic meter of concrete. The benefit of cement with the State Emblem of Quality is 7-8 percent of the wholesale price of uncertified cement.

At the same time, the observance of all the requirements for a product with the State Emblem of Quality involves additional expenditures for stabilizing the industrial process, for cooling the clinker and the cement, and for additional tests of samples during steam-curing. These expenditures are 1.7-2.2 percent of the prime production cost at some enterprises.

Compensation should be established for the cement plants' additional expenditures for making products with the State Emblem of Quality and, in order to stimulate its production, a minimal ratio of the economic benefit to the wholesale price of 2 percent, instead of the 15 percent that is called for in the standard scale, should be established, considering the relative stability of the products mix in the cement industry, and the amount of the incentive markup on standard profit for achieving this benefit should be set in the amount of 7 percent.

Organization of the production of new, highly effective types of cement should begin only after approval of the calculations of the economic benefit, the ceiling price, and the markup on the wholesale price (this concerns primarily the especially high early strength cements, special cements, prestressing cements, and others).

Such an approach to the incentives for raising product quality is still necessary also because plans for sales and profit under the new management terms are figured by the enterprise in wholesale prices, without taking into account any markup or discount, but the actual fulfillment is figured to take markups and discounts on the wholesale price into account.

Unless this question is resolved, the cement industry's output during the 11th Five-Year Plan may be left outside the scope of the incentive mechanism for raising its quality that has been established in the national economy.

Calculation of Transport Expenditures. The transport component of the wholesale price for cement by geographic zone was based on Soyuzglavtsement's reporting data on expenditures on rates for all types of transport in the sale of cement. These rates were calculated for each supplying plant (the shipper's rate) and for each administrative unit (the customer's rate) for cement in general, and separately by special type of cement: portland cement of grades 550 and 600, plugging cement, sulfate-resistant cement, decorative cement, aluminiferous cement, and expansible and prestressing cement.

On the average the rate for 1 ton of cement was 1 ruble and 86 kopecks. This is more than the price in the handbook for 1967. The increase was caused by growth in the rate for hauling the binder by water transport and an increase in the cost of shipping it in intermodal transport (rail and water), because of an increase in the amount of hauling to remote regions of Tyumenskaya and Arkhangel'skaya Oblasts, the Yakutskaya and Komi ASSR's, and other places.

For the types of transport that are larger in scale, the railroad charge for shipping cement was reduced from 1 ruble and 89 kopecks to 1 ruble and 69 kopecks, as a result of further rationalization of hauling and improvement in the siting of cement enterprises in the country.

The rates for hauling plugging cement (6 rubles per ton) and decorative cement (4.6 rubles per ton) are extremely great. This fact testifies to the necessity for further efforts to organize the production of these types of cement in regions close to the points of use.

With a view to providing for stability of settlement prices and to preventing an accrual of Soyuzglavtsement losses in the sale of cement as a result of structural shifts in its production mix, by type and by grade, and also in sales by

zonally differentiated prices (change in freight-traffic schemes), it is necessary, where there is an increase in output volume at the enterprises, and where the settlement price level is higher than the industry average, that a reserve of profit be left for Soyuzglavtsement at the level that has prevailed recently.

NIItsement conducted a check, jointly with Soyuzglavtsement, of the financial results from the sale of cement, and they established that Soyuzglavtsement's profit of 1.5 percent of the cost of the cement sold to customers in wholesale prices c.i.f. the consignee's railroad yard is necessary and sufficient for making settlements.

Principles of Forming Price-Differentiating Zones. In accordance with standard practices instructions, when the draft of the handbook for wholesale prices for cement was being developed, the zonal differentiation principle was retained, eight zones being established. The composition of the geographic regions of each pricing zone was made up to depend upon the level of aggregate expenditures for the production and transporting of cement, which is established from the expenditures for the production of the cement in settlement prices for each plant that delivers a definite amount of cement to a given oblast, upon the transport component, which is based upon Soyuzglavtsement data on cement freight traffic, upon transport expenditures in accordance with the plan for 1980, and upon the reserve for Soyuzglavtsement, which was adopted as 1 percent of the sum of the sales by zonally differentiated wholesale prices.

The new pricing handbook eliminates the deficiencies inherent in previous handbooks--the "raggedness" of the zones, under which neighboring oblasts or Union republics with approximately identical total expenditures proved to be in completely different pricing zones.

Now the principle of assigning neighboring oblasts to a pricing zone no farther than a contiguous one is basically maintained, and the difference in prices between zones will not exceed the transport expenditures for delivering cement from a neighboring oblast (or republic) that is included in a contiguous zone (table 2).

Table 2

Zone	Cement consumption, millions of tons	Adopted interval for total expenditures, rubles	Difference in total expenditures on the average among zones		Transport expenditures for the zone, rubles
			Rubles	Percent	
I	18.3	Less than 18.5	1.6	9	1.25
II	14.1	18.5-20.5	1.5	8	1.20
III	38.7	20.0-21.7	1.7	8	1.33
IV	23.0	21.7-23.0	1.7	7	1.91
V	12.0	23.0-25.0	2.0	8	1.77
VI	7.1	25.0-27.0	2.0	7	3.15
VII	4.0	27.0-35.0	-	-	2.06
VIII	1.8	More than 35	-	-	19.4

The groupings of the types of cement and the sequence of their inclusion in the handbook of wholesale prices have been arranged in accordance with the

classification groupings of the All-Union classifier and taking price-setting requirements into account.

Special attention was paid during the price-revision process to strengthening the mutual links of prices and standards and to omitting from the handbook output that is produced under obsolete standardizing and technical documentation.

As a result of the changes in wholesale prices, the cost of cement under Pricing Handbook 06-01 will be raised by 25.6 percent on the average. The raises will enable profitable operation of practically all cement industry enterprises, improvement of the ratio of wholesale prices for cement of all types and grades through the use of unified price coefficients, and more complete reflection of the socially necessary expenditures for cement production, taking into account changes in the prices of the resources consumed.

COPYRIGHT: Stroyizdat, zhurnal "Tsement", 1982

11409

CSO: 1821/154

NEW KILNS FOR DRY-PROCESS CEMENT PRODUCTION DESCRIBED

Moscow TSEMENT in Russian No 5, May 82 (signed to press 27 Apr 82) pp 3-5

[Article by Engineers V. N. Lyamin and P. L. Tikhomirov (VNIItsemmash [All-Union Scientific-Research Institute for Cementmaking Machinery]: "New Kiln Units for the Dry Method of Production"]

[Text] Kiln complexes with rotating kilns, kiln-mounted cyclone heat exchangers, decarbonizer-reactors and grate-type clinker coolers are called for in new dry-method production lines with a productivity of 3,000-5,000 tons of clinker per day, using a predecarbonized raw-materials mix, the first of which is planned for installation at the Krivoy Rog, Nev'yansk and Rezina Cement Plants.

The kilns, 4.5x80 and 5x100 meters in size, are similar in design solutions and are distinguishable only by size. The SMTs-4 and SMTs-9 kilns are of identical size--4.5x80 meters--but differ in the degree of completeness of outfitting at delivery. The parts of the charging assembly of the SMTs-4 kiln are delivered by foreign companies, and the kiln is outfitted with the three-stem six-orifice mazut nozzle and drive with planetary reduction gear. The parts of the charging assembly of the SMTs-9 kiln, which is of domestic manufacture, calls for a gas burner for burning the fuel, and the reduction gear for the drive is cylindrical and three-stage.

The kiln's body consists of separate cylindrical ring shells that were welded during assembly into a whole pipe. To lend rigidity to the body where the support bands and the drive crown gear are installed, the shell's thickness is increased in comparison with the spanning shells.

At the kiln's intake and outlet ends, foreplates are mounted to secure the lining and to lend rigidity to the conical end shells. The plates are cast from high-alloy high-temperature steel.

Bands, whose inner diameters are somewhat larger than the outer diameter of the mounting surface of the banded shell (taking shim thickness into account), have been set in support units. During kiln operation, as the body heats up and undergoes thermal expansion in the radial direction, the gap between the bands and the body becomes minimal, and, as a result, the band comes into close conjunction with the body. Support shoes that serve to prevent the bands from shifting to the side have been installed at the ends of the bands.

The furnaces that are 4.5x80 and 5x100 meters in size will be equipped with welded-in bands as they are mastered by the Volgotssemash plant by the electro-slag remelting method.

In order to sense the loadings on the kiln body from the refractory lining and the material being roasted at the places where the bands are installed, roller supports have been specified that consist of two support rollers, at the journals of which four-row conical radial roller-contact bearings have been installed. For the sensing of axial forces, paired thrust cylindrical bearings have been mounted on one side of the axis of each support roller. Liquid circulation of the bearings at individual lubricating points has been called for.

In order to warm up thickened oil in the bearings during winter startup of the kiln, electric heaters have been built into the bearing housings and resistance thermometers, which monitor the bearings' temperature, have been installed. Information about this is transmitted to the kiln operator's control panel.

For sensing axial forces that are transmitted from the kiln's body to the supports, and also for periodic axial shifts of the furnace body in order to allow equal wear of the support roller and the bands, the kiln complexes are equipped with a system of hydraulic supports that enable the support rollers to stand without bending relative to the bands, increasing their longevity. The support rollers of the hydraulic supports are shifted along the kiln's axis by hydraulic high-pressure cylinders. For feeding oil to the cylinders and for proportioned decanting, a separate pump station has been installed.

The 4.5x80-meter furnace has been equipped with a single electromechanical drive which consists of a girth gear, a subgirth gear, the main and auxiliary electric motors, and reduction gears. There is also an additional slow-rotation motor, which is switched on during automatic welding of the girth joints of the kiln's body.

For fastening the girth gear to the kiln's body, hinged, flat-link hangers are used, whose designs call for the capability to compensate for temperature deformations of the body.

With a view to smooth startup and regulation of kiln rotation speed over a broad band, the main DC electric motor, for whose feed a thyristor converter is used, has been installed on the drive.

The drive for the 5x100-meter furnace is a dual drive, but all its members have been unified with the drive for the 4.5x80-meter furnaces, so the dual drive is, in essence, two paired drives.

Seals that allow the least leakage of outside air into the kiln at the established operating regime and that prevent the discharge of dust from the kiln during disturbances of the unit's industrial and thermoaerodynamic operating regimes have been installed on the kiln at places that adjoin the charging and discharging heads on the kiln.

The discharging head, which joins the kiln with the loading shaft of the clinker cooler, is a fixed, installed chamber, which has orifices for entry of the discharging end of the kiln and the necessary constructional elements of the sealing installation.

There is a double-wing rollaway door for introducing the mazut nozzle or gas burner into the kiln at the opposite end wall of the head, as well as an inspection port and a repair hatch. The dimensions of the door opening allow the passage therein of machines for the mechanization of lining operations.

The terms of the order involved a potential for operating the 4.5x80-meter furnace on mazut or gas and the 5x100-meter furnace on mazut. In accordance with this, the kilns' designs and the outfitting shipments called for the kilns to be equipped with mazut nozzles and gas burners, which are mounted on a support structure, which is equipped with mechanisms for axial shift and angular rotation of the nozzle and burner. For safe lighting of the fuel's flame, the nozzle and the burner have been equipped with an ignition-protection device.

When using the mazut nozzle, the best spraying of the fuel into the kiln's firebox space is attained by feeding primary air through the nozzle into the kiln from a high-pressure fan. The primary air is 10-12 percent of the total air consumption needed for combustion of the fuel in the kiln.

The kilns have been supplied with a device for automatic measurement of the body's temperature, the basic element of which is an optical pyrometer, which is moved along the body on a special cart on rails by means of a cable mechanism. The results of the measurements are recorded at the kiln operator's control panel. If the body's temperature exceeds the permissible limits (250-300 degrees C) at any section, an installation for cooling the body is switched on at the given section. The installation consists of a collector that is located under the kiln and has a number of blower nozzles that are closed by valves. The cooling air is fed into the collector by fans. For cooling the body at a definite section, it is sufficient to turn on the fans and manually open the valves at the required place on the collector.

The 4.5x80-meter SMTs-4 furnace includes the SMTs-20 kiln unit, which is assembled at the Krivoy Rog plant; the SMTs-9 includes the SMTs-26 of the Nev'yansk plant; and the 5x100-meter SMTs-29 includes the SMTs-27 of the Rezina plant.

Test models of the 4.5x80-meter furnaces were fabricated by the Volgotesem mash plant, and their specifications are cited in table 1.

Table 1

Indicators	Rotating kiln by size (meters) and cyclone heat exchangers	
	4.50x80 SMTs-9	5x100 SMTs-22
Labor productivity, tons per day.....	3,000	5,000
Specific heat consumption for roasting clinker (taking consumption in the decarbonizer into account), kilojoules/kg	3,550	3,430
Deviation, percent.....	4	4
Number of supports.....	4	4
Number of hydraulic supports.....	3	3
Kiln rotating frequency when operating on the main drive, revolutions per minute.....	0.6-3.5	0.6-3.5
Power of the drive's main electric motor, kilowatts.....	400	400x2
Weight of the kiln, tons.....	1,145	1,500
Weight of the lining, tons.....	650	925

The SMTs-19 and SMTs-36 fan heat exchangers provide for preliminary thermal treatment of the raw-material meal prior to its entry into the decarbonizer reactor and the rotating kiln by means of the heat of the waste gases.

Both heat exchangers are similar in design and layout solutions, differing only in size.

The heat exchanger consists of two parallel arms of cyclones that are installed vertically in four stages, joined to each other by gas ducts. In order to transfer material from one stage to another in the lower discharging portion of each cyclone there is a discharge hopper that is connected to the gas duct that draws the dust and gas mixture off from the lower cyclone and into an upper cyclone. In both arms of the cyclone heat exchanger, two cyclones each have been installed in the first, second and third stages, four cyclones in the fourth stage.

The raw-material meal enters the decarbonizer from the second-stage cyclones at a temperature of about 720 degrees C, and it enters the rotating kiln from the first-stage cyclones at a temperature of up to 840 degrees C.

The hot waste gases that have been formed as a result of fuel combustion in the rotating kiln and in the decarbonizer enter the mixer with the raw-material meal that is suspended in them. In the mixer they are mixed and fed into the first-stage cyclones, in which the gases are separated from the meal and are sucked through the gas duct to the second stage cyclones. In this channel the gases are enriched with the raw-material meal, which enters from the third-stage cyclones. Next the cycle of separating the gases from the meal in the cyclones and the spraying of the meal in the gases in the gas ducts is repeated along the remaining stages of the heat exchanger. As a result, the gases are cooled and, at the outlet of the fourth-stage cyclones, their temperature is 300-330 degrees C.

All the cyclones, gas conduits and discharge hoppers have been made of welded sheet steel and lined with refractory materials with a view to minimizing heat loss to the environment and to protecting their metal walls from overheating. The liner can be made of heat-resistant concrete, refractory brick or a combination of these two types of refractories.

Under normal operation the gases from the fourth-stage cyclones enter the kiln-mounted stack over the descending gas duct and then go either in the raw-material milling unit or pass through the installation for cooling and moistening the gases in the furnace-mounted electrical filter.

Test models of SMTs-19 cyclone heat exchangers were fabricated by the Volgotsemash plant. Their specifications are shown in table 2.

The SMTs-29 decarbonizer reactor (see the figure) is organically connected--operationally and physically--with the kiln-mounted SMTs-19 cyclone heat exchanger.

The decarbonizer reactor provides a high degree of decarbonization of the limestone--the basic component of the raw-materials mix--before it enters the rotating kiln. It is accomplished by the mode of intensive heating of the raw material meal in the suspended state in a swirl chamber, where the meal enters along chutes from the cyclones of the second stage of the cyclone heat exchanger. Fuel--mazut or natural gas--is fed into the swirl chamber through the mazut nozzle or the gas

burners, and also heated air is brought from the clinker coolers along tangential branch pipes.

Table 2

Indicators	Cyclone heat exchangers	
	SMTs-19	SMTs-36
Productivity, tons of clinker per day.....	3,000	5,000
Temperature of the gases, degrees C:		
Gases that enter the first-stage cyclone from the rotating kiln and decarbonizer reactor.....	900	900
Gases at the outlet of the fourth-stage cyclone.....	300-330	300-330
Temperature of the materials, degrees C:		
At the intake to the decarbonizer-reactor.....	720	720
At the intake to the kiln.....	840	840
Degree of decarbonization of the material at the kiln intake.	0.8	0.8
Number of arms.....	2	2
Number of stages.....	4	4
Inside diameter of the cyclones, millimeters:		
First stage.....	5,800	7,500
Second stage.....	5,800	7,400
Third stage.....	5,600	7,300
Fourth stage.....	3,500	4,700
Weight (without lining), tons.....	352	500

The major portion of the fuel--50-60 percent of the total amount consumed in the kiln assembly--is burned in the decarbonizer.

The swirl burner, which is placed vertically on the swirl chamber, fulfills the role of an ignition device, and fuel enters it in large amounts, as does heated air from the clinker cooler.

During firing and startup of the installation, primarily the flame of the swirl burner nozzle is lit.

The hot dust and gas mixture, which is at a temperature of 1,000-1,050 degrees C when it comes from the swirl chamber over the gas duct, enters the mixing chamber, where it is mixed with the gases that have arrived from the rotating kiln.

The mixture that has been formed, which is at a temperature of about 900 degrees C, enters the first-stage cyclone of the cyclone heat exchanger.

In the lower part of the mixing chamber there is a drive narrowing arrangement whose moving damper can regulate the cross section of the narrowing in order to provide optimal conditions for operating the system under various regimes, that is, for putting the aerodynamic resistance of the kiln and the decarbonizer into equilibrium.

The hot waste gases from the kiln pass into the mixing chamber through the charging head.

The raw-material meal, which has been caught in the first-stage cyclones of the cyclone heat exchanger at a temperature of about 840 degrees C., is moved along the chutes into the discharge head, and then it enters the rotating kiln along the charging chute.

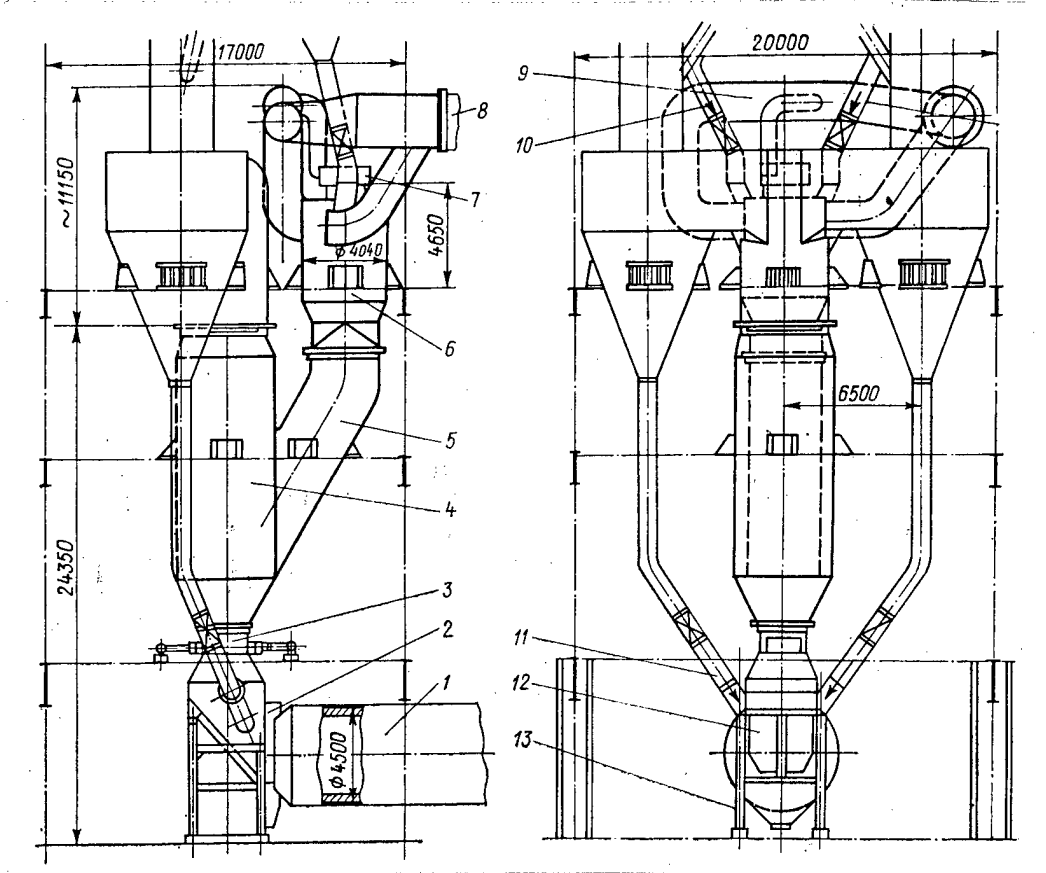

The SMTs-29 Decarbonizer Reactor

1. Rotating kiln, 4.5x80 meters.
2. Seal of the charging end of the kiln.
3. Narrowing device with drive.
4. Mixing chamber.
5. Gas conduit.
6. Swirl chamber.
7. Swirl burner.
8. Air duct for feeding heated air from the clinker cooler.
9. System of air ducts for feeding heated air into the swirl burner and the swirl chamber.
10. Entry of the raw-materials meal into the swirl chamber.
11. Entry of the raw-materials meal into the kiln.
12. Charging head.
13. Metal-structure support.

All the elements of the decarbonizer have been lined inside with a view to protecting the metal walls from overheating and to reducing heat losses to the environment to the minimum.

The operating principle of the grate-type clinker coolers that are included in the kiln units corresponds to the generally accepted scheme for such mechanisms. The clinker is shifted along the grate lattice with the simultaneous mixing of its bed

by a tilting reciprocal motion of the movable grates at a certain angle to the horizontal.

All the space at the grate has been divided by partitions into separate chambers, and the cooling air is fed into them independently.

Scraper conveyors, two for each cooler, have been designed for collecting spills of small lumps of clinker.

Special installations are used to cool and moisten the waste kiln gases and to regulate their temperature automatically within the prescribed limits, prior to feed into the electrostatic precipitators. The main operating organ of this installation is a cooler, the body of which is a vertically installed pipe. The gases are cooled and moistened within its inner cavity with water which is sprayed by special nozzles, which are brought into action by high-pressure (2.5 MPa) pumps.

Under a normally flowing process, the hot stack gases, which constitute waste from the kiln unit, are sent to the raw-materials grinding unit, where they are used to dry off the raw material. Therefore, the gas-cooling installation is switched on for operation only when, during operation of the kiln units, the grinding unit stops for some reason and it is not possible to use the heat of the kiln waste gases that it contains.

A component part of the kiln assemblies is the system for automatic monitoring and control of the operating processes (ASR), which provides the prescribed technical and economic indicators for operation of the assemblies.

The ASR consists of three basic subsystems: the collection and processing of information; generation of control actions; and automatic control of the operating processes.

In order to accomplish these functions, each kiln unit has been outfitted with a process control computer (UVM), which periodically polls and processes the signals of analog and discrete sensors, and also computes and generates control actions in the direct digital control (NTSU) regime. Automatic control is exerted, moreover, by a number of subsystems that are realized in analog equipment. A potential for remote control of actuating mechanisms is also called for.

The information monitoring complex, which is intended for realization of the ASR functions, has been developed in such a way that the indicating instruments for monitoring the most important parameters of the process are concentrated at the kiln-operator's control panel, and the other instruments, which do not require continuous monitoring, have been installed on a monitoring and regulating board.

A major portion of the information has been presented on UVM arrangements, and analog monitoring has been retained only for the most important operating-process parameters.

Arrangements for sampling along the track all the necessary indicators of rarefaction, pressure and temperature and measurers of the magnitudes of the flows of materials and gases, and for monitoring the consumption of waste gases have been introduced into the design of the units.

The use of UVM's within the kiln unit provides for implementation of the lower level of the structure in future automated control systems (ASUTP's). The upper level will be implemented during the design of the technological line by means of the installation of a better-developed process-control computer complex (UVK), which solves the tasks of optimization, responsive reporting and control, computation of technical and economic indicators, and so on.

The first SMTs-20 kiln unit, with a productivity of 3,000 tons of clinker per day, will be erected at the Krivoy Rog plant.

Use of the kiln units with decarbonizers of the raw-material meal will help in the further saving of fuel in the cement industry.

COPYRIGHT: Stroyizdat, zhurnal "Tsement", 1982.

11409

CSO: 1821/154

METALWORKING EQUIPMENT

DEVELOPMENT OF INDUSTRIAL ROBOT PRODUCTION DURING 1981-1985

Moscow PLANOVOYE KHOZYAYSTVO in Russian No 6, Jun 82 (signed to press 25 May 82)
pp 91-95

[Article by V. Lebedev, deputy department chief, Gosplan USSR]

[Text] Accelerated rates of growth in industrial production are based on the introduction of high-efficiency facilities for automating and mechanizing technological processes and transportation between operations. This task is being carried out successfully in large-series and mass production through the introduction of automatic assembly lines. Substantial difficulties stemming from the wide nomenclature and frequent changes of objects of production are encountered in solving problems of automation and mechanization in series and small-series production. Under these conditions it becomes best to use automatic program-controlled manipulators (industrial robots), manipulators and mechanical hands.

Industrial robots are a new means for integrated automation of production which differ in principle from traditional methods in their universality (multifunctionality) and rapid readjustment to new operations. Their adoption, which is the final stage in integrated automation of series and small-series production, creates the prerequisites for developing fully automated adjustable lines, production sections and industries.

The present intensive development and expanded employment of industrial robots and manipulators in the USSR and CEMA member countries results primarily from the attempt to increase labor productivity, to ensure stable high quality of product, to provide safety engineering and to reduce production costs. A second factor, which is no less important, is the shortage of personnel both for work requiring high qualifications as well as work which is simple but monotonous and fatiguing or harmful to the health.

Over the past seven or eight years, robot engineering in the USSR has moved from the creation of the first experimental models to the organization of series production and industrial adoption. More than 100 models of industrial robots and manipulators have been developed for automating stamping, mechanical working of parts, electroplating, casting, welding and painting, as well as assembly and other technological operations. Production has begun of individual complexes of machinery for pressure casting which are equipped with industrial robots, as well

as automatic adjustable sheet stamping lines based on mechanical presses with capacity of up to 100 tons equipped with industrial robots and individual "robot mill" modules. Automated sections are being built.

Nonetheless, the rates of assimilation, organization of developments and amount of production and introduction do not meet the requirements of the economy. The lack of coordination in robot engineering work results in unjustified duplication of technical developments, and the application of particular manipulators is not economically well founded. A unified methodology must be developed for designing and fabricating universal as well as simple, inexpensive industrial robots and manipulators. When universal industrial robots are introduced at individual enterprises, they must be "stripped" of the stages and functions not needed in particular types of production, which leads to unjustified expenses. Minstankoprom, Minpribor and Minelektrotekhprom have not yet initiated series production of a number of component articles for industrial robots, hydraulic and pneumatic equipment, special electric motors, program control systems, as well as various transducers and other products. Industrial robots and manipulators have generally been developed fully for automating machine building, although non-machine building industries have significantly more workers involved in manual labor.

Design institutes have not undertaken sufficient study of the possibilities of employing industrial robots and manipulators in their own branches, and are making practically no provisions for their introduction in the plans for new and rebuilt enterprises. It would be best for the ministries and departments to examine the plans for rebuilding and constructing enterprises during the 11th Five-Year Plan and correct them to allow for automation of technological processes by providing industrial robots and manipulators for production. This will make it possible to determine the demand for them more accurately and to organize the required scope of production.

The prospects for the development of robot equipment over the next 10 years are outlined in the integrated program for scientific research and planning and design work on creating and assimilating automatic manipulators up to the year 1990, which has been confirmed by GKNT, Gosplan USSR and the USSR Academy of Sciences. The program has provisions for creating manipulators for machine building, for the coal and mining industry, for ferrous and nonferrous metallurgy, for agriculture, for the light and food industry and other branches of the economy. It also contains tasking for the ministries and departments to introduce microprocessor-controlled industrial robots with sensing devices, as well as new types of component articles, hydraulic drives and hydraulic equipment, pneumatic drives and pneumatic equipment, electric motors, electric equipment, program control systems and various transducers and other articles.

While work was underway on the program, Gosplan USSR and GKNT received more than 200 suggestions from various branches of industry regarding the creation of industrial robots and automated complexes equipped with robots. For this reason, the integrated program will be expanded and supplemented as the suggestions are worked through.

In implementing the resolutions of the 26th CPSU Congress, the CPSU Central Committee accepted the decree "Measures for increasing the production and widespread application of automatic manipulators in the branches of the economy in the light of the directive of the 25th CPSU Congress". The task imposed is to use industrial robots and manipulators to automate heavy and dangerous work as much as possible in all branches of the economy and to ensure that this equipment is developed rapidly. Lead ministries have been identified for these purposes which are to be responsible for creating, producing and introducing industrial robots and systems of equipment using them, as well as providing component articles and spare parts. Non-machine building ministries, e.g., Minugleprom SSSR and Mintsvetmet SSSR have also been tasked.

The 11th Five-Year Plan includes provisions for building nine times more industrial robots, balanced manipulators and automatic operators for electroplating than during the 10th Five-Year Plan. More than twice as many of these were built in 1981 than in 1980. Major tasks have been imposed on the Ministry of the Machine Tool Building and Tool Industry.

One-fourth of the industrial robots and automatic operators for electroplating which are earmarked for production during the 11th Five-Year Plan will be built by Minstankoprom enterprises, including equipment for automating metal cutting mills (31.2 percent), forging and pressing machines (27.9 percent), foundry equipment (11.8 percent), woodworking equipment (4.3 percent), as well as for equipping electroplating lines (24.5 percent). The list of industrial robots, manipulators and systems equipped with them which have undergone testing and have been recommended for series production during 1981-1985 includes more than 100 models.

Analysis of existing domestic and foreign designs of robots which have been put into industrial use has indicated that simpler robots with four degrees of mobility must be used to automate most metal cutting mills, forging and pressing machines, foundry and woodworking equipment, as well as loading and unloading operations; more complex devices with six or seven degrees of motion are needed for welding, painting, assembly and other processes. Approximately 75-80 percent of all production during the 11th Five-Year Plan will comprise simpler industrial robots with four degrees of movement; 20-25 percent will have 6 or 7 degrees of movement. Of all robots produced, 38 percent will be pneumatically driven, 42 hydraulically and 20 electromechanically. The proportion of the latter will be increased in the future.

Machine building ministries must accelerate the organization of series production of robots, as well as tie them in to equipment which is being produced and create various standard and automated systems, automatic lines, sections and automated shops. This will make it possible to provide minimal human intervention in production, and will allow the equipment to be operated for two or three shifts.

Generally speaking, the foundation for automated systems employing industrial robots and manipulators should consist of mills, presses, foundry and other technological equipment which is series-produced by enterprises in large numbers and which is used for integrated processing of parts. The criterion in selecting equipment is the degree of automation at which it is possible to switch over to

automatic work without serious design reconfiguring.

Analysis done by Minstankoprom has indicated that of all of the machine tools produced during 1981-1985, over 400 models can be equipped with industrial robots. When this is done, wherever the time to process one part does not exceed 3 to 5 minutes, it is best to use an automated technological complex consisting of a machine tool and an industrial robot. If this time exceeds 3-5 minutes, it is economically more profitable to use a group of machines and an industrial robot. Besides the equipment, industrial robots and manipulators, an automated technological complex must include auxiliary equipment: transporters, conveyors, orienting storage devices and receiving devices, etc.

In most cases, technological equipment should be modified in order for it to operate automatically without human intervention, and equipped with electronic units to provide communication between the robot and the equipment, to input instructions and provide automatic blocking, to automate clamps, holders, catchers, etc. Other problems which must be solved at the same time include monitoring tool and blank consumption, removal of waste, lubrication of stamps and forms, etc.; blanks must be prepared in amounts which allow the industrial robots to operate for two or three shifts without human intervention.

It would be expedient for the Central Scientific-Research Institute of Robot Building and Technical Cybernetics of the Leningrad Polytechnical Institute imeni M.I. Kalinin of Minvuz RSFSR, as the lead organization in developing automatic program controlled manipulators for the entire economy, in conjunction with leading machine building ministries, to develop an integrated program to produce standard unified construction of transportation facilities, facilities for feeding and removing blanks and waste, as well as fittings and other auxiliary equipment for the creation of automated systems equipped with industrial robots and manipulators. The Institute must also begin to study the possibilities of employing industrial robots in the economy. In order to reduce the nomenclature of industrial robots and manipulators, to unify their construction, to increase their output and to reduce their cost, organization of series production of these robots and manipulators employing modular construction must be accelerated. All of this requires that Minstankoprom, Minelektrotekhprom and Minpribor accelerate the industrial production of unified modules and miniature series of component articles which will provide the base for producing modular manipulators for all branches of the economy. According to the calculations of specialists, 11 pneumatic, 14 electric and 18 hydraulic modules can serve as the base for configuring industrial robots for practically any application.

Unified program control systems and unified control program software must be developed for complex and self-teaching industrial robots. The USSR Academy of Sciences, Minpribor and Minvuz USSR have been tasked to coordinate the appropriate work.

One serious and urgent problem is to accelerate the introduction of robots and manipulators in industry. Experience in introducing numerical program controlled machine tools indicates that only in sections containing these machines can all of their advantages be realized. Therefore, industrial robots and manipulators must, as a rule, be delivered as part of technological equipment, automatic lines

and complexes, or allocated to the enterprises so that they can build automated lines, sections and production on the basis of existing equipment.

The efficiency of robots increases significantly when they are used in groups: labor productivity increases by at least a factor of 2-4, and sometimes as much as 6-8; capital investment and servicing expenses become relatively smaller. For example, according to the calculations of specialists at NII shinmash in Yaroslavl', a complex of machinery equipped with a system of industrial robots is being built in cooperation with enterprises for making radial tires. The employment of the robotized complex of machinery at the Yaroslavl' Tire Plant will provide annual savings of 9.5 million rubles and will free about 270 workers. The total savings to be gained from introducing complexes such as this for making tires for various purposes will be approximately 200-250 million rubles.

The lines equipped with program-controlled automatic manipulators - industrial robots which perform the most difficult and dangerous work - which are produced by the Tambov Galvanic Equipment Plant make it possible to free 17,000 workers and to increase labor productivity in electroplating by a factor of 2.5-3, and to protect hundreds of thousands of tons of metal from corrosion. For example, integrated automated production of gears is to be implemented in 1985 at the "Yelgavsel'mash" plant. An automated shop for assembling color television sets will be put into operation at the "Moscow Electron Tube Plant" association. A shop such as this for producing printed circuit boards will be put into operation in 1982 at the "Elektron" production association; the Khar'kov Electromechanical Plant "KhEMZ" will implement an automated integrated nonferrous foundry shop employing technological equipment which uses industrial robots and manipulators. The Moscow Electromechanical Plant imeni Vladimir Il'ich will create a section for mechanical processing of large electric machinery parts; the Machine-Building Plant imeni V.I. Lenin at Novokramatorsk will implement a sheet stamping section; the Krasnoluchinsk Machine Building Plant - a section for assembling and welding conveyor chutes; the Moscow "Krasnyy Bogatyr'" production association - a technological section (producing rubber footwear) an automatic manipulator, finishing conveyor and trimming machine, etc. These facilities will become the outpost of advanced experience in the use of systems equipped with industrial robots within their own branches, as well as others. Starting in 1983, Gosplan SSSR has decided to include in the state plan for the economic and social development of the USSR assignments for the ministries and departments to introduce automated complexes, sections, shops and production equipped with industrial robots and manipulators.

Major successes in robot engineering have been achieved by the CEMA member countries: Bulgaria, Hungary, GDR and Czechoslovakia. These countries have introduced a number of industrial robots and manipulators to automate processes and machine building and are building the necessary component articles. In addition, the CEMA countries have developed measures to employ standardized units and parts to initiate the production of automatic program controlled manipulators (industrial robots) for various branches of the national economy of these countries.

Gosplan SSSR, in conjunction with Gosstab SSSR and interested ministries and departments of the USSR, is now developing a position on the order of planning the production, distribution and delivery of automatic program controlled manipulators

which will be adopted in 1982. It can be said that a new subbranch for automating technological processes - robot engineering - has appeared, which will be developed at rapid rates.

In order to ensure superior development of annual and long-range plans for the economic and social development of the USSR in terms of producing and introducing industrial robots, providing component articles, developing capacities for their production, balancing their distribution, and to expand cooperation among CEMA member countries in the area of creating new types of industrial robots, manipulators and component articles for them, the Directorate of Machine Building of Gosplan SSSR should create a special robot building subdivision. In order to coordinate scientific-research and design work, the creation and acceptance of prototypes of industrial robots and manipulators and to monitor their technical level it would be advisable, in our opinion, to examine the question of organizing a coordinating council within GKNT.

Implementation of the measures provided for the 11th Five-Year Plan will make it possible to carry out successfully the task established by the 26th CPSU Congress in the area of robot engineering.

COPYRIGHT: Izdatel'stvo "Ekonomika", "Planovoye khozyaystvo", 1982

6900

CSO: 1821/141

METALWORKING EQUIPMENT

ROBOTICS: APPLICATIONS, DEVELOPMENTS

General-Purpose Robot

Moscow MOSKOVSKAYA PRAVDA in Russian 1 Aug 81 p 3

[Article: "General-Purpose Robot, In Accordance with Plant Plan"]

[Text] Monday, July 27. The process of checking out a robot-serviced section has now been begun at the Stankokonstruktsiya plant.

A robot has mastered the lathe operator's trade. It's not just a single machine that it's capable of servicing, though. A single-track runway has been laid around the machines for it. It can run along this track for an entire shift, insuring, without tiring, the continuous operation of its machines. A sensor arm moves the objects around. And not small ones either, but fairly good-sized ones. Great weights are no problem for this machine-operating robot, however. It is a success in the role of loader as well. The required piece has now been positioned on one machine. At this point, another calls the robot. The device understands this signal language very well. So it immediately moves to a machine which has already finished working a piece and is awaiting another.

The principle underlying the operation of the automated section is already familiar to Moscow machine builders. The unique equipment involved, developed by specialists at Stankokonstruktsiya and ENIMS [Order of Lenin Institute for Experimental Scientific Research on Metal-Cutting Machines], is already in operation in capital production facilities. There is now a section like this at the Dinamo plant. The one Stankokonstruktsiya specialists are now checking out is headed for another Moscow facility, the Krasnyy proletariy [Red Proletariat] machine tool-manufacturing plant. Plans call for it to be installed in this enterprise's machine shop No. 1. The new automated section will be turning shafts.

What advantages are to be derived from using an industrial robot to service our machine tools? The first "plus" is that it reduces the number of specialists required to attend the operation of these machines. A single operator can alone fully monitor the functioning of both the robot and the machines. And what is more, this increases the productivity of the labor involved in performing these operations some 20 per cent. This is no small increase when we consider the fact that, in accordance with the program provided him by his builders, the robot services a number of machines at once and entirely appropriately merits the title of multiposition lathe operator.

Stankokonstruktsiya specialists will be building five sections like this this year. Some of them will go to Dinamo, a delivery address with which the plant is already familiar. Stankokonstruktsiya is filling orders for the capital's industry on schedule and with production of superior quality. Thirty automated sections and some 100 industrial robots--this is the intensive program of industrial reequipment the plant has planned for the five-year period, a program which will see the application of advanced scientific and design concepts. It will be upon the pace at which this program is accomplished that will depend the production efficiency of the many capital enterprises which employ the Stankokonstruktsiya product. Krasnyy proletariy, too, should in the years immediately ahead become a major manufacturer of machines equipped with industrial manipulators. This will require modernization of the plant itself. ENIMS and Stankokonstruktsiya stand at the wellsprings of the robotics of the future.

Principles, Applications of Robotics

Tallinn SOVETSKAYA ESTONIYA in Russian 8 Sep 81 p 2

[Article by Kh. Tiysmus, doctor of technical sciences, head of electric department, Tallinn Polytechnical Institute: "There's a Robot Knocking at the Door, Science for Practice"; passages enclosed in slantlines printed in boldface]

[Text] The development and introduction of miniature control devices and industrial robots are opening up truly revolutionary possibilities. They should be employed on the most extensive scale possible.

L. I. Brezhnev
(from his report to the 26th CPSU Congress)

The party and government have twice over the past two years considered it necessary through their decrees to focus attention on the problem of increasing the production of and then introducing automatic manipulators with program control (industrial robots) during the 1981-1985 period.

The Central Committee of the Communist Party of Estonia and the Estonian SSR Council of Ministers have outlined a program of measures which will accelerate the introduction of robots into our republic economy.

These decrees, numerous conferences of specialists, robotics exhibitions and material published in the technical literature give evidence of the systematic efforts under way to accomplish the tasks outlined by the 26th CPSU Congress in "Basic Directions of USSR Economic and Social Development for the Years 1981-1985 and for the Period Extending to 1990." The launching of the Eleventh Five-Year Plan is thus seeing our domestic robotics making fundamentally new advances and moving into the ranks of the most important directions of scientific and technical development for the coming decade.

Interest in robots, of course, is not a development of today or yesterday. Curiosity about them was first stirred by representatives in the fields of the humane studies,

primarily by writers of phantasy. We then saw robots as mechanical devices obligatorily resembling human beings or animals. These conceptions formed the basis for an entire direction of scientific studies concentrating upon what are referred to as anthropomorphic, walking machines with a three-dimensional kinematic system involving many degrees of motion. The results of these studies are being applied to the development of wheelless walking machines for movement over rough, broken terrain, including the surface of other planets, the ocean floor etc.

The needs of industrial production, however, have substantially modified our traditional conceptions of the geometrical shapes a robot would have as well as of the tasks it would perform. Today's industrial robot is a working machine performing a variety of motions involving the movement of raw materials, pieces and parts, billets, tools, finished products etc. Since it has many degrees of motion, it is best suited to perform auxiliary and transport production operations, operations in which monotonous and fatiguing manual labor have until now been employed. The robot's capability of moving in accordance with a variety of plans and the ease with which the program governing the operations it is to perform can be reorganized or modified permit the human being to turn over to it many processes involving a great deal of physical labor. /In a word, the robot should work where it would be difficult, harmful, dangerous or, because of extreme environmental conditions, entirely impossible for a human being to work./

Until only recently the possibilities of employing efficient, reliable robots were greatly limited due, among other things, to the cumbersomeness of the hardware involved and inadequately developed control principles. Today, however, microelectronics having undergone a period of rapid development and miniature computers incorporating microprocessors having found their way into many spheres of technology, the task of moving the robot into the ranks of the basic devices employed in the production process has now become the pressing task of the day.

Fantasy writers were doing a good thing in propagandizing the notion of replacing human beings with machines with the object of making their lives easier. But this propaganda yielded some unexpected results as well: it fostered the idea that machines were omnipotent. It confirmed the belief, frequently unfounded, that robots could do everything. We therefore frequently encounter the desire to use robots anywhere and everywhere, a desire unaccompanied by any attention given to the economic aspects of the activity involved. I will, of course, be forgiven an exaggerated comparison, but I don't think the necessity will ever arise, nor would there ever be developed a robot which could replace Galina Ulanova on the stage of the Bol'shoi Theater despite the fact that as long as two centuries ago there were many notable mechanical experts who could create dancing doll ensembles on the stages of miniature theaters which executed movements in accordance with a strictly specified program.

The first-generation robots which we have already seen developed and introduced also function in accordance with a strictly specified program. The operations they perform imitate human physical labor.

But it is not only the physical labor that tires a human being, he becomes fatigued intellectually as well. And since a human being is continually proceeding in his activity on the basis of a model of the real world already elaborated in his brain, then in order to be able to perform certain human intellectual functions, a robot, accordingly, should also have a model of its environment. We can then expect from it actions which follow logically from the current conditions of its environment. Thus

has evolved a second generation of robots provided with sensors imitating the human sense organs. Most importantly, these include a system of machine vision, on the basis of which the automatic manipulator functions by an "eye-hand" system. Robots, moreover, have also to be able to "sense" motion, speed, acceleration, force, temperature, geometrical dimensions, color, electromagnetic field and sometimes sound, radiation level etc. Second-generation robots are therefore of a more complex structure than their wired, preprogrammed predecessors. This does, of course, increase their cost as well and forces us to look very carefully at the technical-economic aspects of their application.

The most advanced and complex machines are now the robots of the third generation, which are equipped with artificial intelligence components. Endowed with a capability of solving certain logical problems, and functioning in accordance with programs in memory, instructions to perform certain general tasks and information from their "sense organs," these robots have to work out their own behavioral tactics and strategy so as to be able to perform their assigned tasks most efficiently. Any change in the conditions under which they perform their tasks generates corrections in the strategy and tactics selected. Intensive work on the development of third-generation robots is now under way in many of the world's scientific centers, including those of our own country.

The robotics strategy for today consists in judiciously introducing these devices into the national economy. But at this point we could encounter at least two kind of difficulties. Excessive optimism in descriptions of the omnipotence of the robot, with its superintelligence, superstrength, superdurability and endurance and its superspeed, can give rise to disenchantment upon familiarization with the limited potential industrial robots really offer. The pessimist, on the other hand, will interpret the possibilities robotics offers even today as an agreeable legend and not move promptly with any practical application.

/Success in introducing robots depends not only upon the people who build them--the scientists, designers, engineers and manufacturers. A no less important role belongs to the specialists, workers and managers of the enterprises in which the robots are being introduced./ It is not always easy to abandon traditional conceptions and views of production processes which have taken shape over the course of decades. Thoroughgoing study of the possibilities robots offer and, occasionally, a radical change in technologies employed taking these possibilities into account can help overcome this psychological barrier.

A new machine forcibly introduced into an old production process looks just as powerless as an automobile would under stone age conditions: it could not function effectively since there would be no roads or gasoline.

The replacement of a single worker by a robot on a lathe will yield no substantial economic benefit: we will still have to bring in a programmer, troubleshooter etc. to service the thing. It would be another matter entirely if we could put the robot in charge of the operation of several machines or presses, thereby turning them into a well-coordinate smooth-running system of equipment, section or shop. /Practical experience indicates that under these conditions a single industrial robot will free two to three workers and double both the utilization of equipment and the productivity of the labor involved./

There is also danger along the way toward effective introduction of robots. What we see now, when the total number of industrial robots and manipulators in the country is nearing 6000, is a shortage of robots in many branches of the national economy. Key USSR ministries are therefore developing and fabricating these machines primarily to meet their own requirements since there is no special branch manufacturing robots for all. This course toward the decentralization of production poses the danger that a very large number of different types of machine will be developed representing different levels of sophistication, that is, that great volumes of resources will be expended but with the possibility that the best models will not be the ones to go into production.

/We need to adopt what is referred to as the modular principle in building our robots/, to organize series production of standard individual structural robot components with different functional characteristics. /On this basis we will be able to assemble robots of the required complexity for specific tasks and operations./ Specialists are of the opinion that this approach will make it possible to double the number of robots manufactured at a given level of expenditure.

Twenty-two of the country's ministries are now developing some 100 types of automatic manipulators and industrial robots with program control with the object of employing them as bases upon which to build metalworking, forging and pressing, casting, wood-working, welding, painting, lifting and transporting and other equipment systems. Work is under way on the development of standardized integrated electric drives, electric motors and electrical equipment for controlling automatic manipulators, modular adaptive program-control systems, measuring sensors for machine vision systems etc. /All this equipment will be available to the production engineer over the course of the Eleventh Five-Year Plan period. But will he be ready for it?/

A decree of the CPSU Central Committee and USSR Council of Ministers has outlined a broad program of training and retraining for robotization for middle- and upper-level specialists. In our republic, the Estonian SSR Gosplan, Minvuz [Ministry of Higher and Specialized Secondary Education] and the State Committee on Vocational and Technical Education, together with the interested ministries and departments, have been charged with the responsibility for studying the question of training for specialists in the spheres of the automation of production processes and the building and employment of automatic manipulators with program control with the objective of satisfying the republic economy's requirements in the sphere of robotics.

The development of robots and robotics systems has already for several years now been included among USSR Minvuz specialties. (Great strides have been taken in this field at the Moscow Higher Technical School imeni N. E. Bauman under the direction of Professor Ye. Popov, corresponding member of the USSR Academy of Sciences.) Operator training, moreover, has now been approved as a specialization in itself. /Within the framework of its "electric drive and the automation of industrial production facilities," the Tallinn Polytechnical Institute will also be introducing a specialization designated "systems for program control of industrial equipment and robotics systems."/

The years will pass. We will see full production automation raised to a fundamentally new level. Intelligent robots with extraordinarily wide ranges of capabilities will come to take their places beside the robots of the first and second generations. We will be freed from fatiguing physical labor, while many problems in logic and computation will also be turned over to machines.

But what will then be left for the engineer to do?

Norbert Wiener, the patriarch of cybernetics replies: "The future leaves little hope for those who expect robots to create for us a world in which we will be freed of the need to think."

Courses in Robotics Training

Moscow PRAVDA in Russian 20 Sep 81 p 2

[Article N. Petrov: "Robot Builders, Fact and Commentary"]

[Text] The Moscow Machine-Tool Institute is now giving instruction in a new faculty--automation and control systems for production processes.

This faculty comprises two newly created departments: "Industrial Robots and Robotics Systems" and "Automation of Design and Control." Professor Aleksandr Semenovich Kiselev, Doctor of Technical Sciences and dean of the faculty:

"Creation of the new faculty is a concrete response on the part of our institute to the CPSU Central Committee's well-known decree concerning measures to increase production and the extensive application of automatic manipulators in branches of our national economy. Strictly speaking, the students in our VUZ have long since studied the basics of robotics; manipulators have been the subjects of degree and course projects, and models of devices like this are now operating in institute laboratories and workshops. But the organization of a special faculty will help make the training of new specialists in this new vocation more thorough and objective-oriented.

"The new faculty will have a total of some 600 students. A hundred have been accepted for the first class; two hundred will be coming in from the instrument-making faculty, which existed until this year, and we will pick up another two hundred from the students of other faculties. The first class of engineers in the new specialization will graduate in 1985.

"The national economic requirement for specialists in robotics is a great one. Creation of the new faculty has been seen as an attempt to satisfy it to some extent. We are proposing that, through their mastery of the necessary knowledge in the sphere of the development and operation of automatic manipulators, our graduates become at the same time specialists of a more broad-ranging competence. For the fact is that only by developing a thorough knowledge of modern-day technology that we can design truly up-to-date robots. I would note here in passing that the basics of robotics will also be taught in other faculties of our institute. I think nowadays every engineer should be familiar with these basic principles.

Manipulator Drives

UDC 007.52-8

Moscow MASHINOSTROITEL' in Russian No 10, Oct 81 (signed to press 5 Oct 81) pp 8-9

[Article by V. D. Darovskikh: "Manipulator Drives"]

[Text] Manipulator drives, whose efficient employment is to be seen in modular designs, differ with respect to the type of power employed, the nature of the motion

involved and the type of control. There are pneumatic, hydraulic, electric and combination manipulator modules. Recent years have seen designs employing advanced combination electromechanical, electropneumatic and pneumohydraulic drives enjoy the most widespread practical application. Drives with translational and rotational motion in the slave component are equally essential and applicable in manipulator designs. The former, however, have found the greatest practical application and undergone the greatest degree of development. This has been a result of the facts that they are of relatively simple design, that they offer the greater range of versions of basic solutions and that it is easy to convert translational to rotational motion with the use of auxiliary devices. Be that as it may, the last-mentioned quality does not contribute to any simplification of the manipulators themselves, but rather only makes their design more complex, increases their size and degrades their dynamic characteristics.

Modules may be positional modules, fabricated with the incorporation of conventional servo mechanisms, or of a special type (digital, servo, stepping) determined by the specific characteristics of the numerical program control system involved.

Drives must satisfy the following basic requirements: they must provide an accuracy in positioning insuring practical employment of the manipulator, the necessary area for service and operation and the required lifting capacity; they must be able to function at high speed with the desired accuracy and at the same time offer the possibility of operation in both manual and automatic modes of control and regulation and the resetting process must be low-labor-intensive and highly productive and offer minimum permissible metal consumption. The efficiency of drive design is determined as well by degree of reliability, low cost, minimum operational expenses and operating safety.

A combination, vertical-motion digital drive (invention application No. 2919628) offers a simple and compact design, a high degree of unification [standardization], convenience in servicing and program modification, low-labor-intensive programming and regulatable discreteness in the linear motion of the last movable extremity. It can be electro-, pneumo or hydromechanical. The drive is mounted in a housing 1 (Figure 1)

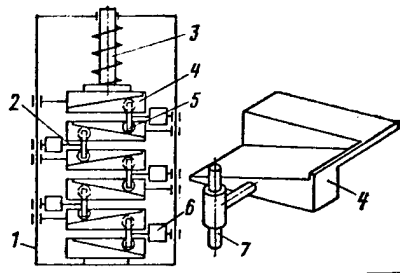

Figure 1

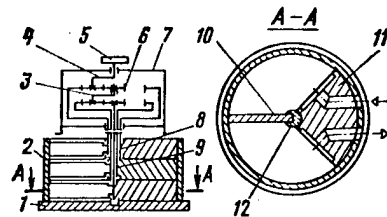

Figure 2

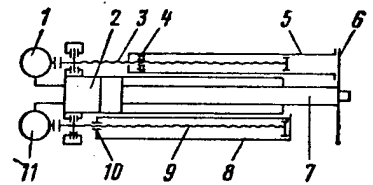

Figure 3

and consists of wedges 4 arranged in parallel and connected through a single axle 7 and rollers 5, which are in contact with the wedges and by means of push rods 2 are rigidly connected with actuating mechanisms 6. The latter are made so as to permit movement relative to the housing along axis 7. The bottom wedge is rigidly secured to the housing, the top wedge being attached to the last movable component of drive 3. A spring is mounted between the housing and the upper wedge.

The last moving drive component moves with the functioning of the power mechanism, which acts on the rollers via the push rod. The rollers move along the supporting surfaces of the wedges. The upper, relative to the power mechanism, wedge rises vertically, moving the wedges above it as well as the last moving drive component and compressing the spring. When two or more power mechanisms function simultaneously, their effective movements are summed, each subsequent power mechanism, except the first, also moving along the axis. With the return motion of a power mechanism or a group of them, the last moving drive component is returned to its initial position by the action of the spring.

A drive providing angular manipulator motion (invention application No. 2883511) is mounted on a base 1 (Figure 2) to which are attached rotating mechanisms 2, which are independent components connected with one another in series. Inside each rotating mechanism are shafts 8, 9 and 12, blades 10 and stops 11. Shafts 8 and 9 are hollow, while stops 11 contain pressure lines. In differential reducer 7, sun gear 3 engages central pinion 6, while sun gear 4 carries the moving end component 5, to which may be connected, for example, the manipulator arm.

When operating pressure is fed to the rotating mechanism through one of the pressure lines (the second being open to the air), the blade advances to the stop. The shaft connected to it moves the corresponding pinion of the differential reducer and, further along the kinematic circuit, the last moving component. If two or more rotating mechanisms function simultaneously, the value of the output information is determined by the sum of the angular motion of each mechanism and the gear ratio of the differential reducer.

This drive is of simple design and offers increased positioning accuracy as compared with other similar modules as well as minimal delay. Improved dynamic design characteristics make it possible to dispense with the use of damping devices. An increase in the number of programmable points, moreover, does not decrease the total angle of rotation of the moving end component.

The positional linear drive in Figure 3 (inventor's certificate 722757) is a combination electropneumatic drive. It successfully satisfies the requirements for operating speed, positioning accuracy and discreteness of moving end component motion. Cylinder 2 (Figure 3) and rod 7 (moving end component) produce its operating power movement. Rod stroke length is governed by insertion of the desired stop nuts 4 and 10 by means of electric motors 1 and 11 and lead screws 3 and 9, which are attached to the cylinder. Operation of the electric motors may be controlled manually or automatically. Rigid stop 6 limits rod stroke. For this purpose, rods 5 and 8, which form sliding pairs with nut 4 and the cylinder 2, are connected to the stop and nut 10. Keyed joints connected to the nonrotating rods and the cylinder keep the nuts from turning. Support points (radial-thrust ball bearings) in the cylinder relieve the electric motors from sudden loads.

The drives discussed here may find application in manipulators of either special or general-purpose design. Their advantage is to be seen especially clearly in the performance of industrial operations requiring a large number of intermediate stops at all coordinates. Modification of trajectory or coordinates of the movement of moving end components requires no long periods of time.

COPYRIGHT: Izdatel'stvo "Mashinostroyeniye", "Mashinostroitel'", 1981

8963

CSO: 1821/036

METALWORKING EQUIPMENT

RENOVATION SLOW AT MAKINSK PISTON RING PLANT

Alma-Ata NARODNOYE KHOZYAYSTVO KAZAKHSTANA in Russian No 2, Feb 82 (signed to press 4 Feb 82) pp 26-27

[Article by M. V. Stepanov: "Drawn-Out Renovation"]

[Text] Mikhail Vasil'yevich Stepanov has worked at the Makinsk Piston Ring Plant imeni V. I. Lenin for 40 years. He has gone from senior designer to chief engineer at the enterprise. In spite of the fact that he is of retirement age, this veteran continues in the ranks. He is currently deputy chief engineer. He has been awarded the Order of Lenin, many medals, Certificates of the Kazakh SSR Supreme Soviet and has been made an Honored Citizen of Makinsk for his many years of conscientious labor.

Our whole country recently marked the 40th anniversary of Hitler's defeat near Moscow. For me, the war years are memorable because it was at that terrible time that the USSR State Defense Committee decided to move the Minchurinsk Piston Ring Plant to the East. In a matter of days, we dismantled the equipment, loaded it onto special trains and shipped it to tiny Makin Station, lost in the endless Kazakh Steppe.

Michurinites and Makinites quickly began supplying the front with products after installing the machines in motor vehicle shops at "Kazzoloto" trust. I remember that once a week a plane landed at a special field not far from the new-born plant. It hauled piston rings for tanks and vehicles and 82-mm mines. Aware of the importance of our work, we labored tirelessly.

It was during those very harsh years that we developed a friendly, close-knit collective and established the dynasty of Makinsk machinebuilders and their glorious labor traditions. In my view, this is the basis of all of today's successes and achievements by the plant workers. And we have had quite a few successes. During the 10th Five-Year Plan, for instance, commodity output production increased 23.2 percent. And labor productivity grew by as much also.

Piston ring production expenditures decreased by 11.2 percent, resulting in 9.2 million rubles of profit. It should be noted that the collective has been consistent year after year in carrying out state plans and meeting socialist obligations. For example, consumers were shipped 85,000 rubles worth of above-plan output last year.

Successes naturally gratify and inspire us to new deeds. But we must not fail to note that the enterprise collective has had to deal with quite a few difficulties. No, we are not complaining about the tautness of the plan assignments. To the contrary, the plant program can and must be increased, as the demand for output is enormous. The plant now ships piston rings to nearly 500 customers, including such giants as the Chelyabinsk, Altay and Cheboksary tractor plants, the Bryansk and Belorussian motor vehicle plants and the Volgograd Engine Plant. Moreover, we export piston rings to 39 other countries.

So what's the problem? Mainly unsatisfactory working conditions. We are working to this day in the same unsuitable motor vehicle repair shops the plant was located in during the war, and production volume has increased many-fold since that time, while the buildings have become dilapidated.

Renovation is under way, but at such tortoise-like rates that one wonders when, at last, we will have utilized the 49.2 million rubles in capital investment the plan calls for. Judge for yourself. During the 17 years since the start of the so-called renovation, only 6.5 million rubles worth of construction work, or 6.7 percent of planned, has been done.

The whole problem is that "Tselinogradtyazhstroy" trust, which is doing the renovation, has paid little attention to our enterprise. Here is a typical example. There are 26 people in the Makinsk construction sector of the Atbasarskaya mobile mechanized column, which is directly concerned with renovating the plant. Only 9-12 of these construction workers are on the project. No comment needed here, as they say.

It has become necessary to create in our city either a mobile mechanized column or a construction administration with an appropriate base. Only this approach will provide an opportunity to accelerate renovation of the enterprise and improve the quality of the facilities being built.

A few words about the allocation of funds for the renovation. We absolutely cannot understand the position of the USSR Ministry of Tractor and Agricultural Machinebuilding, to which our plant belongs: it is not clear whether it is for or against the renovation. Think on this: three times last year, the amount being allocated to renovate our enterprise which was to have been utilized in the 11th Five-Year Plan was cut. Thus, we were initially allocated 8.3 million rubles, then, in accordance with ministry order No 156, 5.3 million, and finally, we recently received a new total -- four million rubles.

I'm afraid that this last figure isn't the final one either. In fact, a year has passed and we don't yet have a capital construction plan for the five-year plan. Such manipulation of monetary resources naturally does not orient our general contractor towards shock work. Rather the contrary, it dampens his enthusiasm.

Officials of the ministry and "Soyuztraktorzapchast'" VPO [probably: all-union production association] visit the plant, wring their hands on seeing the sad condition of the enterprise, and promise assistance. But a check shows that their promises are groundless. We have accumulated three volumes of renovation correspondence but, unfortunately, paper doesn't put up shops.

In reviewing the status of agricultural machinebuilding at the November (1981) CPSU Central Committee Plenum, Comrade L. I. Brezhnev set the task of raising the technical level and improving the reliability and durability of this machinery. We cannot solve the problem just by building new plants, he said. We consequently need to improve the operation of existing enterprises. There are opportunities for doing so. This is precisely what the five-year plan is oriented towards.

The plant needs immediate assistance. The main and auxiliary shop units should be built, the enterprise should be provided with a reliable water-supply and sewage system, the ATS [automatic telephone exchange] and TsZL [central plant laboratory] and dining hall should be put into operation and, finally, we need to begin building the social, cultural and personal-services facilities which the collective urgently needs. In a word, we need to actualize the enterprise renovation plan.

COPYRIGHT: "Narodnoye khozyaystvo Kazakhstana", 1982

11052

CSO: 1821/137

RENOVATION AT VOLGOGRAD HARDWARE PLANT

Moscow MASHINOSTROITEL' in Russian No 3, Mar 82 (signed to press 25 Feb 82) pp 37-38

[Article by association deputy general director A. I. Belov, candidate of economic sciences Ye. D. Postoyeva and candidate of technical sciences I. I. Postoyev: "Effectiveness of Production Renovation"]

[Text] Current demands that production volume be increased and quality be improved with minimal expenditures are met in the shortest time by developing production on the basis of renovation, by fundamentally changing the composition of technological equipment on the basis of modernizing existing units and introducing progressive technology. This is supported by experience at the Volgograd Hardware Plant, which was built in 1932 and is now the basis of the Volgograd Tractor Parts and Standards Production Association. Completely destroyed during World War II, the plant was rebuilt in the post-war period. New forging and tool shops were built in subsequent years, since the old ones had ceased to meet modern requirements.

Planned production renovation was begun in the Ninth Five-Year Plan and the first line was completed by the start of the 11th Five-Year Plan. The association put into operation the main production facility, housing the hardware shop, sectors for heat-treating and galvanizing fasteners, and the spring shop. Also here are service and worker areas, which has enabled us to improve working conditions, and that has had a positive effect on labor productivity growth and personnel stability. A new facility equipped with cranes and hoists was built for warehousing materials, finished products and the central tool and abrasives storage area.

During this time, the proportion of equipment cost in capital investments grew continuously (from 59.4 percent in the Ninth Five-Year Plan to 79.3 percent in 1980), which enabled us to increase output 51.5 percent as compared with the post-war period. The quality of the output being produced also improved thanks to the introduction of automatic lines for heat-coiling large-diameter springs and heat-treating and galvanizing fasteners and driver tools. Thus, we began manufacturing zinc-coated driver tools in 1980 in conformity with GOST [All-Union State Standards] and in response to customer requests, and their production has been increased 2.5-fold.

Whereas the initial task of the renovation was to expand production by eliminating bottlenecks and to improve production and worker-service conditions in conformity with modern requirements, primary attention in the 10th Five-Year Plan was focused on retooling production. This task was resolved in a comprehensive manner by replacing obsolete technological equipment and modernizing existing equipment. The modernization was achieved by:

- increasing equipment productivity through design improvements;
- improving product quality through equipment design changes and by installing additional units on existing equipment;
- raising the level of mechanization and automating equipment operating cycles by equipping it with additional mechanisms, devices, attachments and apparatus;
- improving equipment reliability of operation and lowering operating outlays through design changes and by replacing non-durable parts and subassemblies with improved, more durable ones;
- expanding the technological potential of the equipment.

Equipment modernization resulted not only in a higher technical level of production, but also in a reduced demand for new equipment, since the modernization was done faster than [it would have taken to] acquire and master new equipment. Thus, the association modernized 73 pieces of technological equipment and introduced 68 progressive technological processes for manufacturing and heat-treating bolts, fasteners and driver tools with electroplating during the 10th Five-Year Plan. Moreover, in accordance with the renovation plan, the association introduced 52 automated lines and 102 automatic and semiautomatic machine tools. All this enabled it to save 1.5 million rubles per year.

The tasks of the collective social development plan were also resolved. Thus, introduction of automatic combines to manufacture M18 and M20 bolts enabled us to hypothetically free nine blacksmiths and heaters for other work. A total of upwards of 200 workers were moved to workplaces with better working conditions due to implementation of the association's production renovation plans. The funds being allocated for these purposes have gradually been increasing. Funds to replace and modernize equipment comprised 53.6 percent of all capital investments allocated to retool production in 1975 and 76.2 percent in 1980. Retooling enabled us to raise the level of use of progressive technology. In this regard, the level of labor mechanization also rose, to 58.7 percent in 1980. Along with improvement in technical-economic indicators, there was a reduction in the return on capital (1.31 rubles in 1975 and 1.21 rubles in 1980). This was connected with putting four million rubles worth of treatment facilities into operation and with the use of a significant portion of the production renovation capital investments to create storage facilities, service and worker areas and premises for auxiliary services.

The second line of association renovation is being done in the 11th Five-Year Plan. As a result, fixed assets must be increased by 37.5 percent and the number of workers will increase by only 7.5 percent. Thus, the rates of growth in the technical potential of production connected with increasing production space and with the amount of equipment installed in it will outstrip the growth in the number of workers. However, the rates of increase in fixed assets still outstrips the rates of production volume expansion. This five-year plan, given fixed assets growth of 37.5 percent in the association, production volume will be increased only 13.5 percent. Subsequently, given saturation of the newly

created production space with equipment and utilization of the full capacity of these fixed assets, we propose increasing the return on capital to 1.42 rubles. This five-year plan, we propose improvement in other technical-economic indicators as well: expenditures per ruble of commodity output will decrease by 1.6 percent, the level of labor mechanization will increase to 60.5 percent, and profit will be increased by 12 percent. Capital investments in the second line of the renovation will be recompensed in 2.6 years.

Thus, production renovation done with consideration of improving production and personal working conditions and environmental protection and the diversion of capital investments to these purposes increases the capital-intensiveness of production and lowers the return on capital. In order to increase capital investment effectiveness when renovating production, we need to strive for outstripping labor productivity growth as compared with growth in the availability of capital to labor, which is achieved on the basis of qualitative improvement in the active portion of fixed assets, and foremost in basic technological equipment.

COPYRIGHT: Izdatel'stvo "Mashinostroyeniye", "Mashinostroitel'", 1982

11052

CSO: 1821/137

END