



EDGEWOOD

RESEARCH, DEVELOPMENT & ENGINEERING CENTER

U.S. ARMY CHEMICAL AND BIOLOGICAL DEFENSE COMMAND

ERDEC-CR-261

**DESIGN, CONSTRUCTION, AND PERFORMANCE
OF A PLUME GENERATOR FOR REMOTE SENSING RESEARCH**

19980917 020

C.T. Chaffin
T.L. Marshall

AEROSURVEY, INC.
Manhattan, KS 66502

April 1998

Approved for public release; distribution is unlimited.

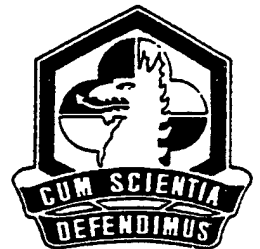

DTIC QUALITY INSPECTED 1

Aberdeen Proving Ground, MD 21010-5423

Disclaimer

The findings in this report are not to be construed as an official Department of the Army position unless so designated by other authorizing documents.

REPORT DOCUMENTATION PAGE			Form Approved OMB No. 0704-0188	
Public reporting burden for this collection of information is estimated to average 1 hour per response, including the time for reviewing instructions, searching existing data sources, gathering and maintaining the data needed, and completing and reviewing the collection of information. Send comments regarding this burden estimate or any other aspect of this collection of information, including suggestions for reducing this burden, to Washington Headquarters Services, Directorate for Information Operations and Reports, 1215 Jefferson Davis Highway, Suite 1204, Arlington, VA 22202-4302, and to the Office of Management and Budget, Paperwork Reduction Project (0704-0188), Washington, DC 20503.				
1. AGENCY USE ONLY (Leave Blank)	2. REPORT DATE 1998 April	3. REPORT TYPE AND DATES COVERED Final; 96 Aug - 97 Dec		
4. TITLE AND SUBTITLE Design, Construction, and Performance of a Plume Generator for Remote Sensing Research			5. FUNDING NUMBERS C-DAAD05-97-P-0616 C-DAAD05-97-P-2053 C-DAAD05-97-P-2130 C-DAAD05-97-P-2842	
6. AUTHOR(S) Chaffin, C.T., and Marshall, T.L.				
7. PERFORMING ORGANIZATION NAME(S) AND ADDRESS(ES) AeroSurvey, Inc., 4700 Tabor Valley Rd., Manhattan, KS 66502			8. PERFORMING ORGANIZATION REPORT NUMBER ERDEC-CR-261	
9. SPONSORING/MONITORING AGENCY NAME(S) AND ADDRESS(ES) DIR, ERDEC, ATTN: SCBRD-RT, APG, MD 21010-5423			10. SPONSORING/MONITORING AGENCY REPORT NUMBER	
11. SUPPLEMENTARY NOTES COR: Robert T. Kroutil, SCBRD-RT, 410-671-1708				
12a. DISTRIBUTION/AVAILABILITY STATEMENT Approved for public release; distribution is unlimited.			12b. DISTRIBUTION CODE	
13. ABSTRACT (Maximum 200 words) A device has been built to generate heated plumes with controlled temperature and composition profiles. The plume generator is intended as a tool to facilitate remote sensing research. This report details construction of the device, provides performance specifications for the plume generator and its components, and includes data illustrating the device's capabilities.				
14. SUBJECT TERMS Emission stack Plume generator Remote sensing Infrared monitoring			15. NUMBER OF PAGES 29	
			16. PRICE CODE	
17. SECURITY CLASSIFICATION OF REPORT UNCLASSIFIED	18. SECURITY CLASSIFICATION OF THIS PAGE UNCLASSIFIED	19. SECURITY CLASSIFICATION OF ABSTRACT UNCLASSIFIED	20. LIMITATION OF ABSTRACT UL	

Blank

PREFACE

The work described in this report was authorized under Contract Nos. DAAD05-97-P-0616, DAAD05-97-P-2053, DAAD05-97-P-2130, and DAAD05-97-P-2842. This work was started in August 1996 and completed in December 1997.

The use of either trade or manufacturers' names in this report does not constitute an official endorsement of any commercial products. This report may not be cited for purposes of advertisement.

This report has been approved for public release. Registered users should request additional copies from the Defense Technical Information Center; unregistered users should direct such requests to the National Technical Information Service.

Acknowledgments

The authors recognize and thank the following personnel who have contributed to the effort represented by this document:

Dr. Bob Kroutil	U.S. Army ERDEC, Aberdeen Proving Ground, MD
Dr. Roger Combs	U.S. Army ERDEC, Aberdeen Proving Ground, MD
Bob Knapp	U.S. Army ERDEC, Aberdeen Proving Ground, MD
Dr. Mark Thomas	U.S. EPA, Region VII, Kansas City, MO
Mike Milligan	U.S. EPA, Region VII, Kansas City, MO
Mike Davis	U.S. EPA, Region VII, Kansas City, MO
Alan Cummings	Dynamac Corporation, Mission, KS
Scott Bradford	Dynamac Corporation, Ft. Riley, KS
Dr. Nathan Chaffin	DOM Associates, Manhattan, KS

Blank

CONTENTS

1.	BACKGROUND	7
2.	DESIGN AND CONSTRUCTION	7
2.1	Design considerations	7
2.2	Construction	7
2.3	Control and Monitoring Instrumentation	8
2.3.1	Plume output temperature	8
2.3.2	Total stack air output	8
2.3.3	Analyte flow control and monitoring	9
2.3.4	Analyte pre-heaters	9
3.	GENERAL OPERATION	10
3.1	Overview of operation	10
3.2	Examples of releases	11
4.	CONCLUSIONS	12
	Appendixes	
	A. Characterizing the plume generator's volumetric output	25
	B. Standard Safe Operating Procedures for the AeroSurvey M-series Plume Generator	27

FIGURES

1	Right side view of plume generator	13
2	Left side view of plume generator base unit only, as configured during transportation	14
3	Rear view of plume generator	15
4	Detail of the in-stack heat exchanger assembly	16
5	Electrical diagram for the plume generator	17
6	Control podium layout	18
7	Analyte flow diagram for the plume generator	19
8	Ammonia levels in plume during release example cited in text	20
9	Plot of mass lost in hydrogen chloride cylinders during a typical release using direct introduction into the heat exchanger assembly, bypassing the flow meters	21

TABLES

1	Major structural and functional components of the plume generator	22
2	Plume generator instrumentation and specifications	22
3	Plume generator performance capabilities	23
4	Plume generator operational log for an ammonia release	24
5	Flow tube calibration data relevant to the ammonia release example cited in the text	24

DESIGN, CONSTRUCTION, AND PERFORMANCE OF A PLUME GENERATOR FOR REMOTE SENSING RESEARCH

1. BACKGROUND

Useful information concerning industrial activities can be derived from infrared remote analysis of plumes emanating from the site. Comprehensive proof testing of such analyses requires access to controlled, full-scale plumes. In support of such testing, a device has been constructed that is capable of generating heated plumes with controlled temperature and composition characteristics.

2. DESIGN AND CONSTRUCTION

2.1 Design considerations

The plume generator has been designed to emulate real-world stacks that might be found in a variety of industrial facilities, such as agri-chemical production plants, petro-chemical production plants, and refineries. The original design specifications for the plume generator included volumetric outputs as high as 2000 cfm, plume temperatures as high as 200° C, and a specific list of target analytes that included ethanol, methanol, ammonia, hydrogen chloride, and sulfur dioxide.

The nature of the target analytes required that all wetted materials used in the construction were either highly resistant to chemical attack or, where the use of such materials was impractical, easily replaceable. For example, SS316 was chosen as the material for all analyte tubing and fittings while less-expensive and readily available galvanized steel was chosen for the 16" diameter stack tubing.

Portability of the plume generator was also a major design concern. The research for which the plume generator was built is conducted at numerous sites around the United States; minimizing overall size and weight would facilitate transportation. Previous field research with controlled releases suggested that on-site portability could also be useful in that it allows on-going experiments to be easily adapted to changing wind conditions.

2.2 Construction

The basic layout of the plume generator is illustrated in Figures 1, Figure 2, and Figure 3. Table 1 lists the major components of the plume generator and provides some details concerning their specifications.

The plume generator essentially consists of a base unit and a vertical stack tube. The stack tube is disassembled from the base unit during transportation to a test site. The base unit is constructed on a lightweight 4' x 8' trailer that allows the base unit to be manually loaded into a larger trailer for long-distance transportation and the plume generator to be manually re-positioned in the field without disassembly of the vertical stack tube.

The vertical stack tube can be almost any length of 16" diameter pipe. Typically, a 10-foot vertical stack section has been used to provide a total stack height of approximately 15 feet. An elbow has been placed on the top of the vertical stack tube for some experiments to produce a horizontal plume release.

The core of the plume generator is a centrifugal blower feeding a combustion plenum. A liquid propane burner resides in the combustion plenum. Heated air from the combustion plenum is fed into an elbow that redirects the air into the vertical stack tube.

Analytes to be released are introduced to the plume via a coil assembly located inside the vertical stack tube. The coil assembly serves as a heat exchanger, vaporizing liquid analytes and pre-heating gases and vapors before they are introduced into the plume. Figure 4 details the in-stack heat exchanger.

2.3 Control and Monitoring Instrumentation

Figure 5 diagrams the electrical layout of the plume generator. The status of the plume generator is controlled and monitored primarily from a control podium mounted at the rear of the base unit. Figure 6 illustrates the layout of the display console on the control podium. Table 2 details the instrumentation used to control and monitor the plume generator's output.

Figure 6 shows a digital panel meter to indicate liquid propane delivery pressure. The sensor for this measurement has not been installed at the time of this writing. The sensor will be installed for future work in which knowledge of propane usage (or, indirectly, Btu/hr) is required.

2.3.1 Plume output temperature

Plume temperature is controlled through adjustment of the propane delivery pressure to the burner. The temperature of the output plume is measured with a type J thermocouple probe extended into the center of the plume, immediately before the exit of the stack tube. Plume temperature is displayed on a digital panel meter in the control console.

2.3.2 Total stack air output

Airflow is largely determined by burner operation but may be adjusted within a limited range through the use of a blast gate installed between the centrifugal blower and the combustion plenum.

The actual volumetric airflow through the stack is determined indirectly. A Pitot tube is located in the center of the plume, immediately before the exit of the stack tube. In conjunction with a differential pressure gauge mounted in the control console, the Pitot tube is used to determine air velocity at the stack exit. Based on knowledge of the stack's flow characteristics (previously determined in calibration efforts, see Appendix A), the air velocity at the center of the stack can be converted to a volumetric flow. Corrections are made to account for the effects

of temperature and humidity on the Pitot tube reading as well as the isobaric expansion of air with increased temperature.

2.3.3 Analyte flow control and monitoring

Figure 7 diagrams the flow of analytes through the plume generator.

Ultimately, all analyte flow rates are determined from mass flux measurements in the analyte storage containers (generally, 5-gallon buckets for liquids that are easily handled or compressed gas cylinders for gases and corrosive liquids), using a load cell.

When flow rates are sufficiently high, the differential mass measurements may be made in the field during the actual release. In high-flow releases of corrosive liquids such as hydrogen chloride and sulfur dioxide, the analytes may be introduced directly into the pre-heater/vaporizer assembly from a pressurized cylinder. In these cases, adjusting the delivery pressure at a pressure regulator mounted to the cylinder controls flow rates.

Low flow rates may make direct mass measurements in the field difficult, due to the limited resolution of the mass measurements and the uncertainty that this poor resolution introduces into any calculation of flow rate over the limited time periods during which field releases typically occur. In these cases, analyte flows are metered through one of two variable-area flow meters with high-precision needle valves mounted in the control console. The variable-area flow meters are calibrated for the low flow rates during off-site flow calibration tests using long flow times. These off-site calibration tests are again based on differential mass measurements of analyte flows.

The variable area flow meters have interchangeable flow tubes and floats made of various materials to provide a wider range of flow rates. The tubes are standard 150-mm flow tubes, incremented every 1 mm. The maximum turndown ratio on any given flow tube/float combination is approximately 15:1, with 10:1 more easily obtained in actual practice. Appropriate flow tube and float material is determined prior to a release based on the desired emission rate and previous flow meter calibration efforts.

2.3.4 Analyte pre-heaters

Measurements of gas flow rates through variable-area flow meters are dependent upon the temperature and pressure of the gas. The effects of pressure are inherently accounted for in the calibration tests. However, as the plume generator is used in widely disparate temperature conditions (-5° C to 40° C, to date), the temperature of gaseous analytes must be controlled for flow meter readings to be consistent.

Each of the analyte flow lines has a gas pre-heater installed immediately prior to the flow meter. Each pre-heater is essentially comprised of 5' of 0.25" O.D. tubing, coiled and wrapped with a thermostatically-controlled heating element. The temperature of the tubing is monitored with a type J thermocouple in intimate contact with the tubing. Temperature controllers mounted on the display console monitor and control the temperature of the gas analyte pre-heaters.

3. GENERAL OPERATION

Table 3 lists the general performance capabilities of the plume generator. Following a brief description of the operation, examples are provided to illustrate the plume generator's capabilities.

3.1 Overview of operation

The operation of the plume generator will only be briefly outlined in this section. Appendix B is a detailed standard operating procedure for the plume generator.

Following the placement of the base unit on the test site, the vertical stack tube support structure is raised, the vertical stack tube is mounted to the base unit, and the vertical stack tube is chained to the erected support structure. Thermocouple, Pitot tube pressure lines, and analyte lines are connected to the appropriate locations on the vertical stack tube and the base unit. A line supplying liquid propane is connected to the propane supply fitting.

The single power cord is connected to 120 VAC power, the GFI breakers are all switched to the on position, and the operation of the digital display panel meters is verified. The blower motor is then switched on, allowing operation of the stack flow system (Pitot tube and differential pressure gauge) to be checked.

The electrically actuated propane valve is switched on and the cover to the combustion plenum opened. Propane is turned on slowly at the manual control valve and the burner is ignited with a hand-held piezo-electric spark igniter. The combustion plenum cover is closed, the manual propane flow valve is turned fully open, and the propane delivery pressure is adjusted to produce the desired plume temperature. The plume generator is now ready to begin flowing analytes.

Liquid analytes are pumped from five-gallon carboys or buckets with small pumps attached to the side of the control podium. A variety of pumps have been tried but the most useful have been small windshield washer fluid pumps that can be purchased quite inexpensively in almost any discount store. These small gear pumps produce high delivery pressures, hold up well to rigors of field operation, and are chemically resistant to the organic fluids pumped to date.

The pump output is directed through the flow meter, where the flow is controlled with a needle valve mounted to the flow meter body. Analyte flows from the flow meter through 0.25" O.D. lines to the entrance of the heat exchanger assembly at the base of the vertical stack tube.

Low flows of gaseous analytes are handled in exactly the same manner, except that no pump is required. Cylinder pressure is used to force the gaseous analytes through the system, with a cylinder-mounted regulator limiting delivery pressure to less than 25 PSI.

High flow rates of gaseous or corrosive liquids with significant vapor pressures (such as hydrogen chloride, ammonia, and sulfur dioxide) are flowed directly into the vaporizer assembly in the vertical stack tube, bypassing the flow meters. Multiple cylinders may be used in tandem, either through individual regulators or through one central regulator, to provide higher flow rates and reduce the effects of auto-refrigeration. In these cases, the cylinders are placed on a raised platform that is supported along two opposite edges. A load cell supports one of the edges so that the weight loss of the cylinders can be monitored and recorded throughout the release. (This requires the weight distribution of the cylinders on the platform to be characterized in calibration efforts, completed at the end of the release as the cylinders are being removed from the platform.)

3.2 Examples of releases

As an example of a release of a gaseous analyte through the flow meters, consider a release of ammonia. Many such releases have been made and one in particular will be used here to illustrate the plume generator's operation and capabilities. In the particular ammonia release used in this example, ammonia was flowed through the flow meters at fifteen relatively low rates, ranging from 0.047 lb./min to 0.003 lb./min. The high emission rate was used at the beginning of the release and then reduced in a series of fifteen steps. Each flow rate was used for about two minutes and another two minutes was used for each rate change. The entire release was performed at a constant target temperature of 200° C and lasted about 45 minutes.

A single flow meter with a #40 tube and a glass float was used for this release. A single cylinder of ammonia was connected via a regulator to the left side input port on the plume generator. Delivery pressure was set to 25 PSI. The plume generator log for this release is shown in Table 4.

Figure 8 is a plot of ammonia levels measured at the output of the stack throughout the release with an active FT-IR system. This particular release has been used as an example because the FT-IR data well illustrates the performance potential of the plume generator. Optimum wind conditions and low flow rates of a gaseous analyte contributed to the quality of the data shown in Figure 8.

It should be noted, however, that the FT-IR data used to validate the plume generator's output usually displays more variance. This variance is largely attributable to the effects of the wind on the plume as it is measured in the open atmosphere. However, with all else being equal, liquid analytes have typically shown greater variance than gaseous analytes which suggests that the plume generator may produce plumes with more uniform composition with gaseous analytes than it does with liquid analytes.

In this release, the float was positioned at the 150-mm mark for the highest flow rate, and then stepped down in 10-mm increments to a final setting of 10 mm. The actual flow rates associated with this flow tube and float combination at each of these settings were determined in calibration trials performed separately. During these calibrations, ammonia was flowed through the tube and float combination at the highest setting and one of the intermediate settings for long periods of time while the mass loss in the supply cylinder was recorded. The flow rate at these

two settings was thus determined directly. The flow rates at all of the other settings were calculated via interpolation between these two settings and zero. The calibration data for this scenario is provided in Table 5.

Releases of most liquid analytes are performed in almost exactly the same fashion as just described for the gaseous analyte ammonia. The only difference occurs in the analyte delivery system, which must rely on pumps to transfer the liquids from their storage vessels to the plume generator.

Releases of liquids with very high vapor pressures as well as high flow rates of gases are performed by introducing the analytes directly from storage cylinders into the in-stack heat exchanger, thus bypassing the variable-area flow meters. In these cases, cylinder pressure is used to force the analytes into the plume generator. Emission rates are determined via measurements of mass lost in the storage cylinders over the course of the release, as described earlier. Figure 9 is a plot of total mass lost over time from multiple cylinders supplying hydrogen chloride for a typical release. The emission rate during a release of this type is inferred directly from the slope of such a plot and the plot's linearity confirms the constant nature of the emission rate.

4. CONCLUSIONS

The plume generator described in this report has been designed and constructed to allow the creation of heated plumes at controlled temperatures and with controlled chemical compositions. The performance of the plume generator has been demonstrated and characterized in terms of the on-board monitoring and control instrumentation as well through the analysis of post-release plume analysis data.

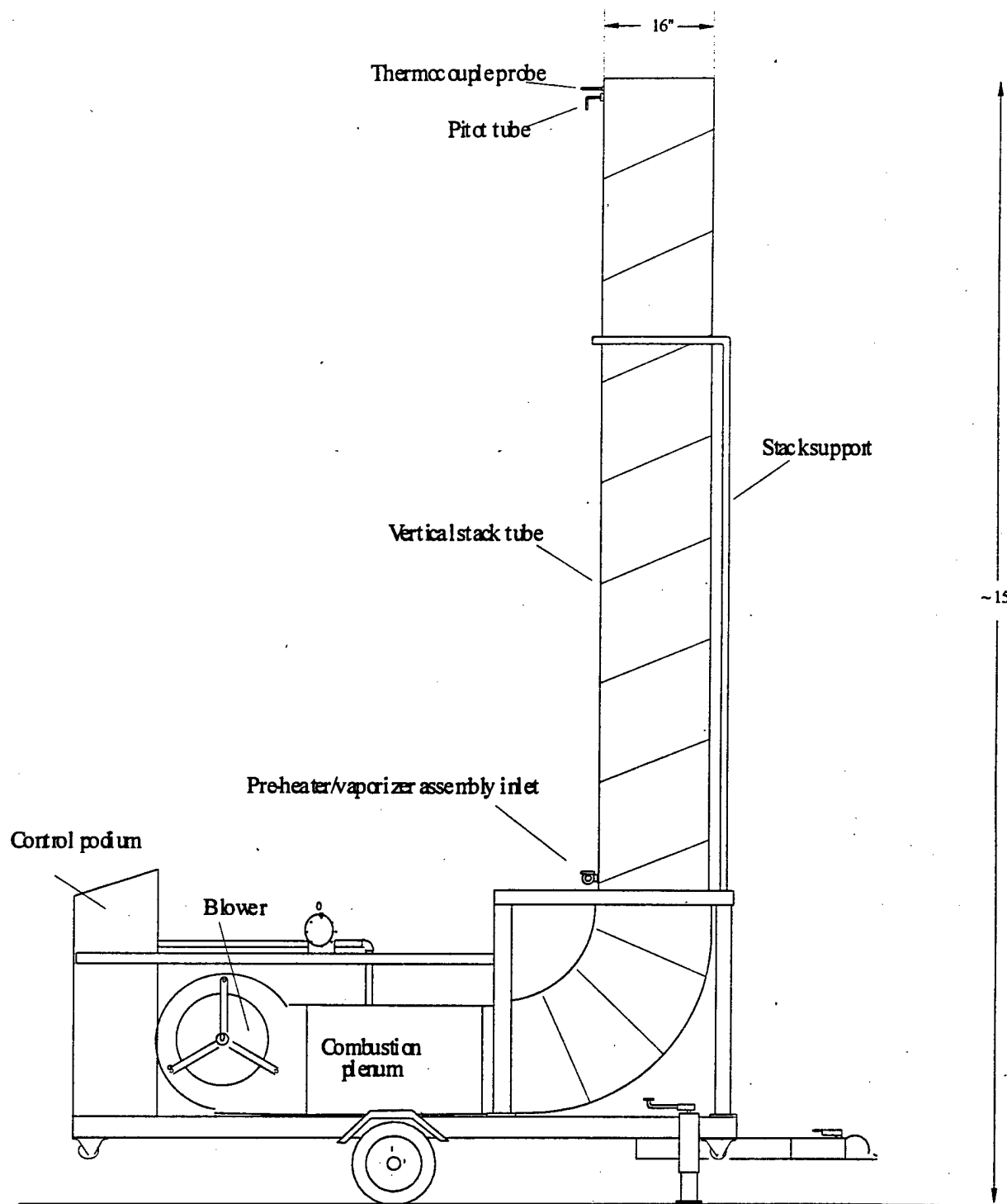

Figure 1. Right side view of plume generator.

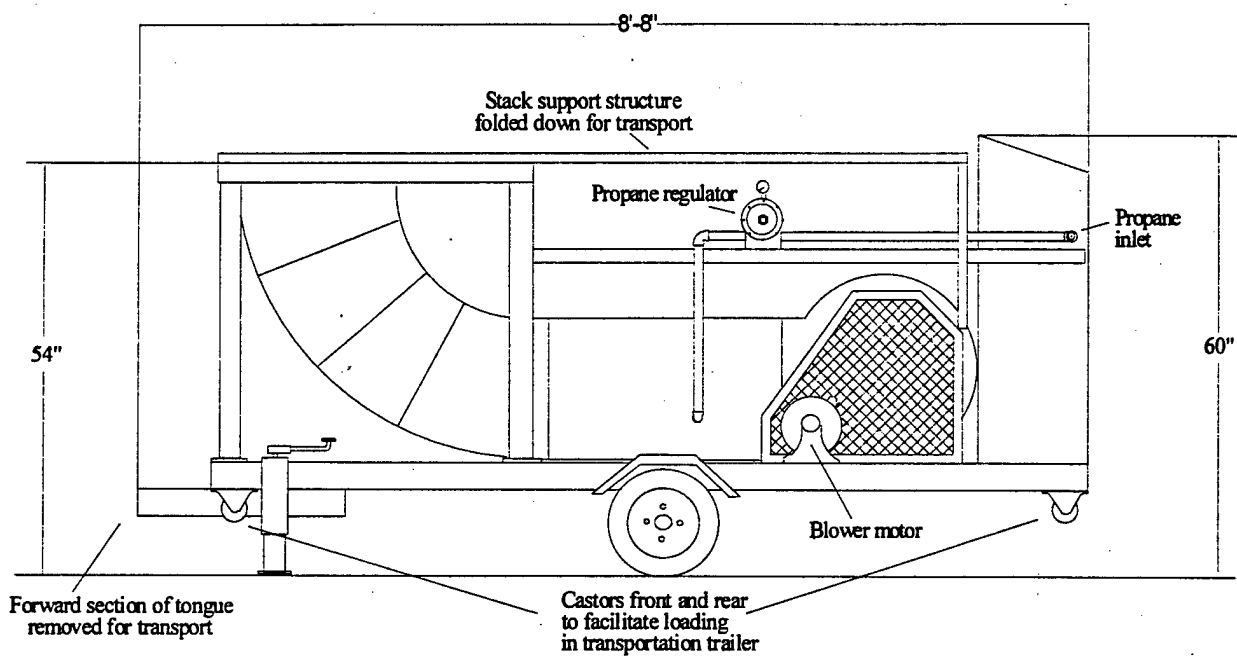

Figure 2. Left side view of plume generator base unit only, as configured during transportation.

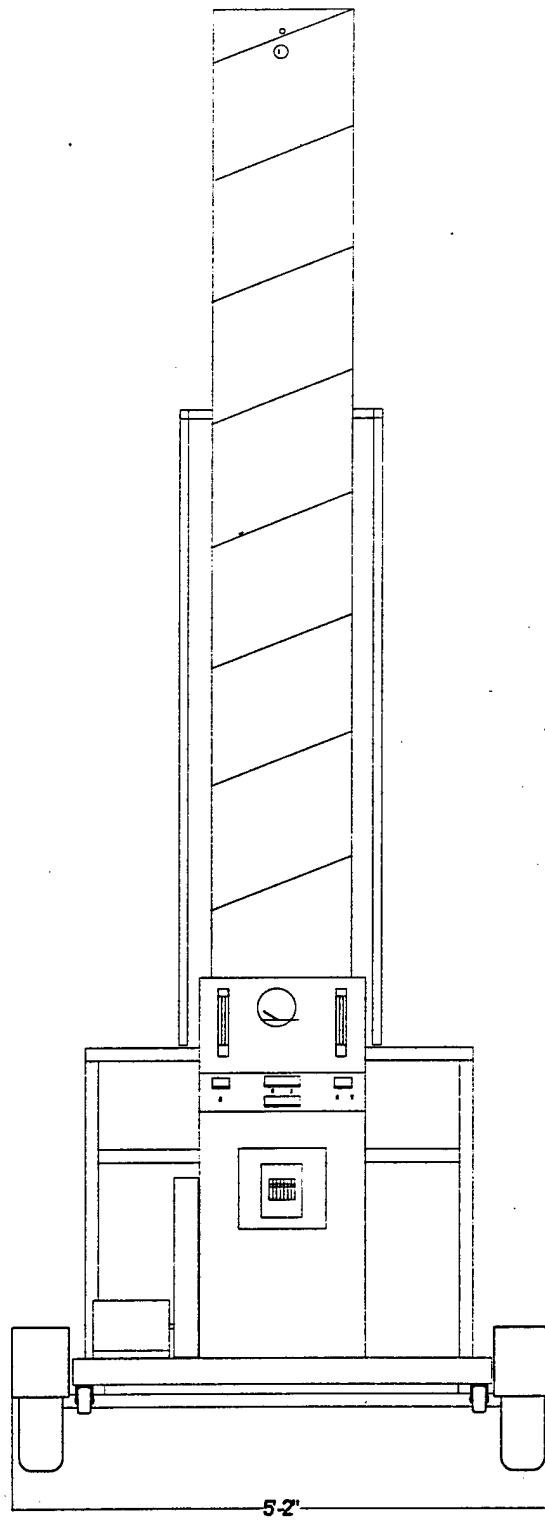

Figure 3. Rear view of plume generator.

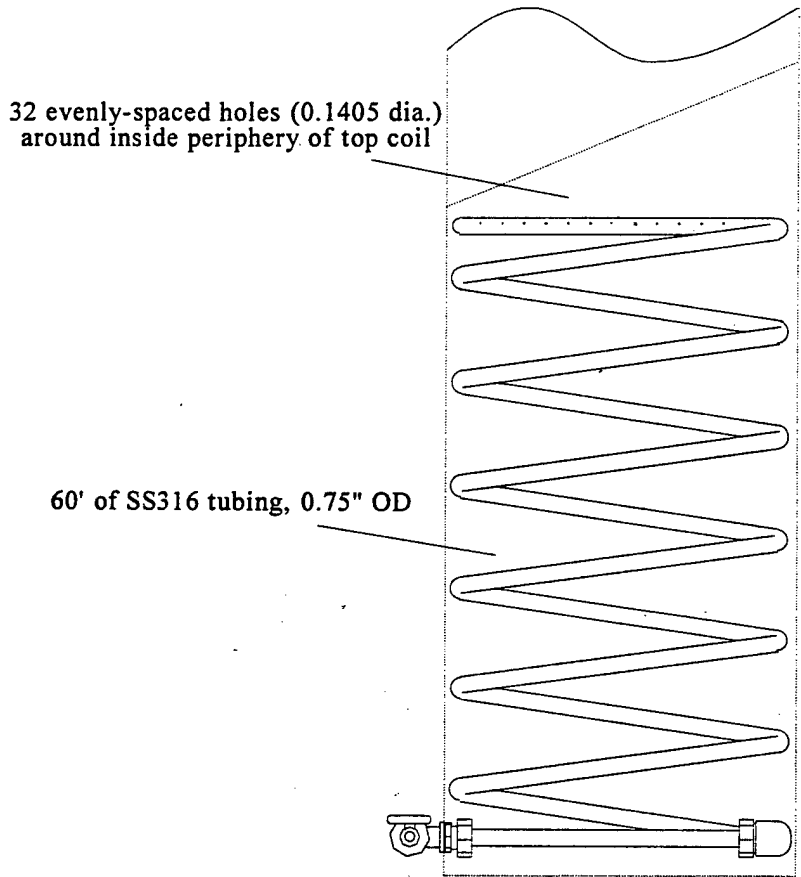

Figure 4. Detail of the in-stack heat exchanger assembly.

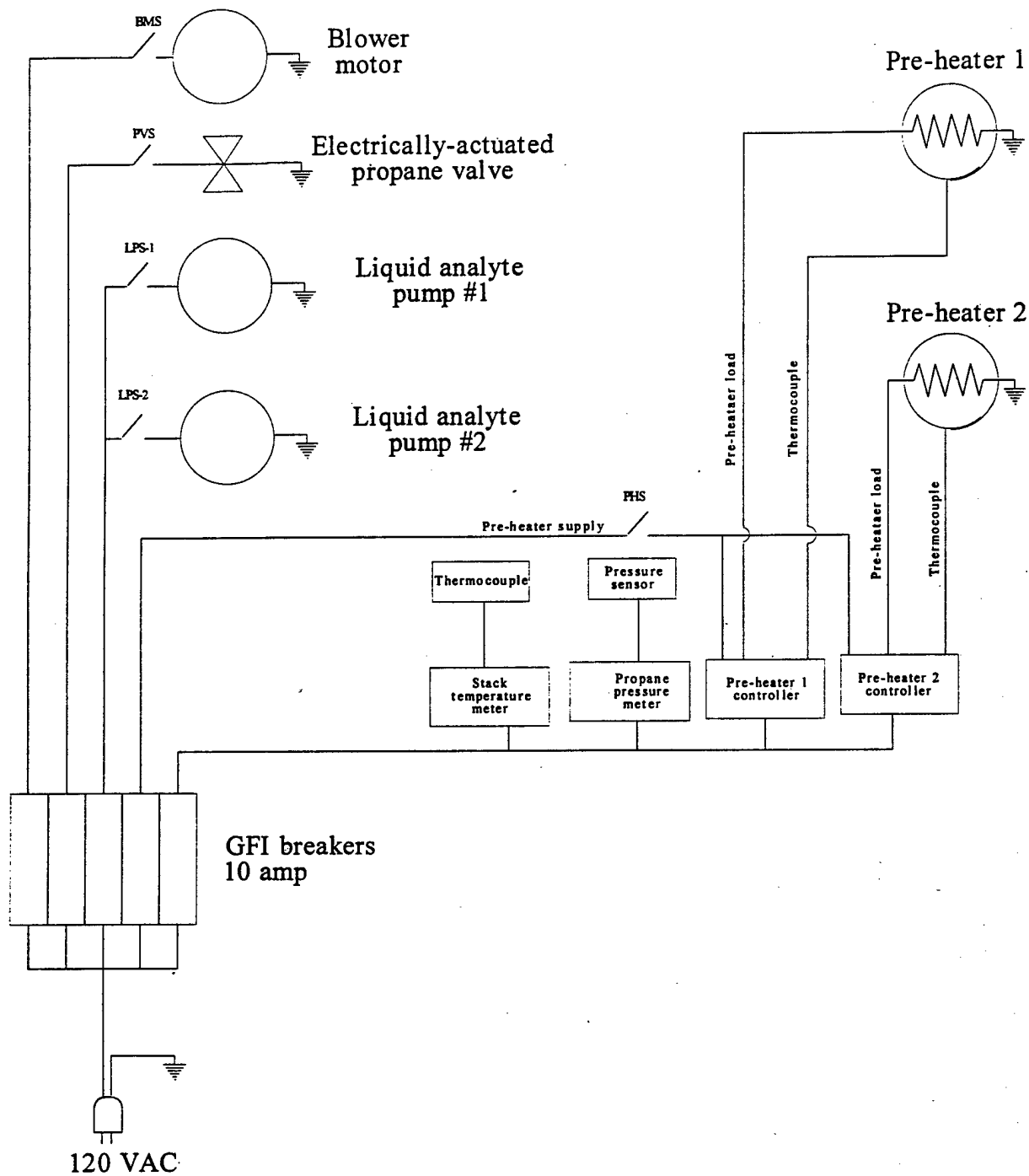
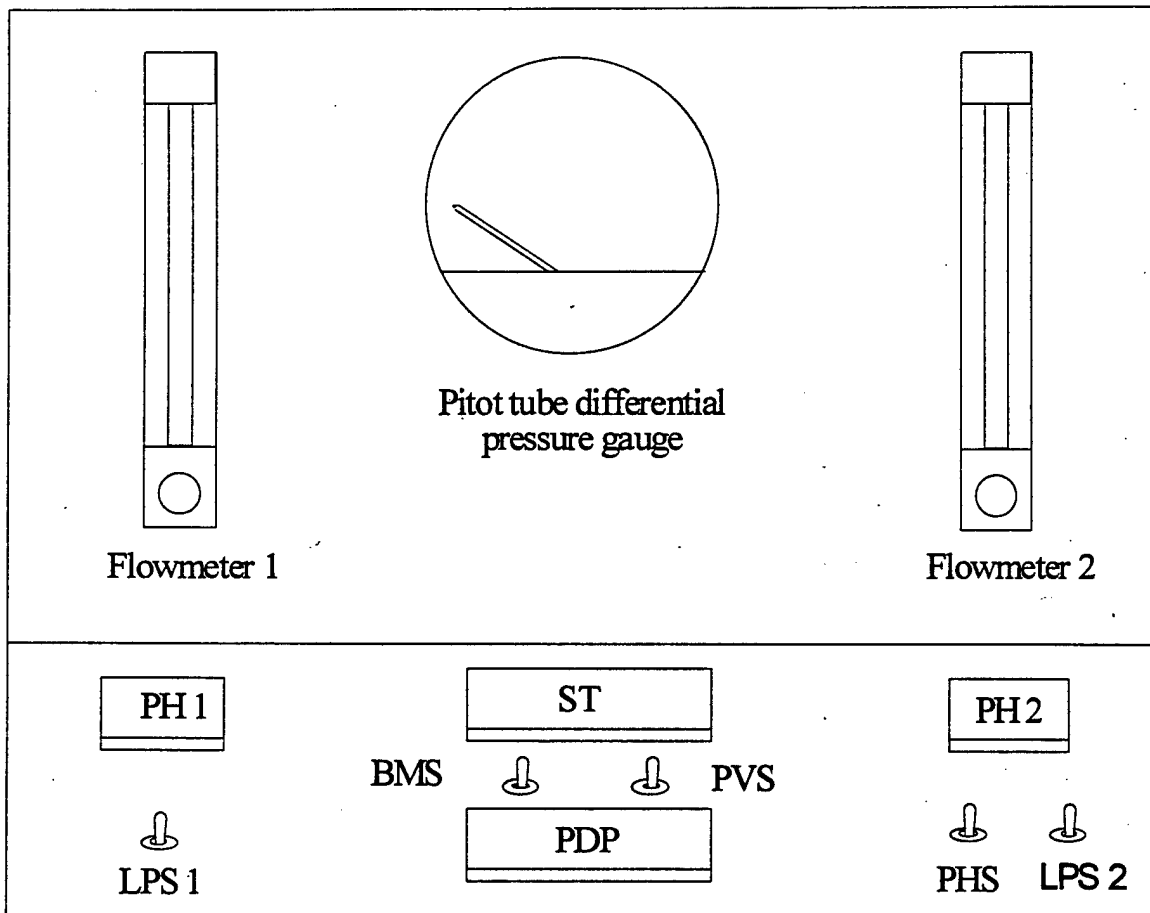

Figure 5. Electrical diagram from the plume generator. Wiring exists for configuration as shown but not all of the components are currently installed. Specifically, the 120 VAC liquid analyte pumps have been replaced with battery-powered DC models (see text) and the propane pressure monitoring instrumentation will be added in the future as needed.



Key:
 PH: Pre-heater controller
 ST: Stack temperature display
 PDP: Propane delivery pressure display

LPS: Liquid pump switch
 BMS: Blower motor switch
 PVS: Propane valve switch
 PHS: Pre-heater switch

Figure 6. Control podium layout.

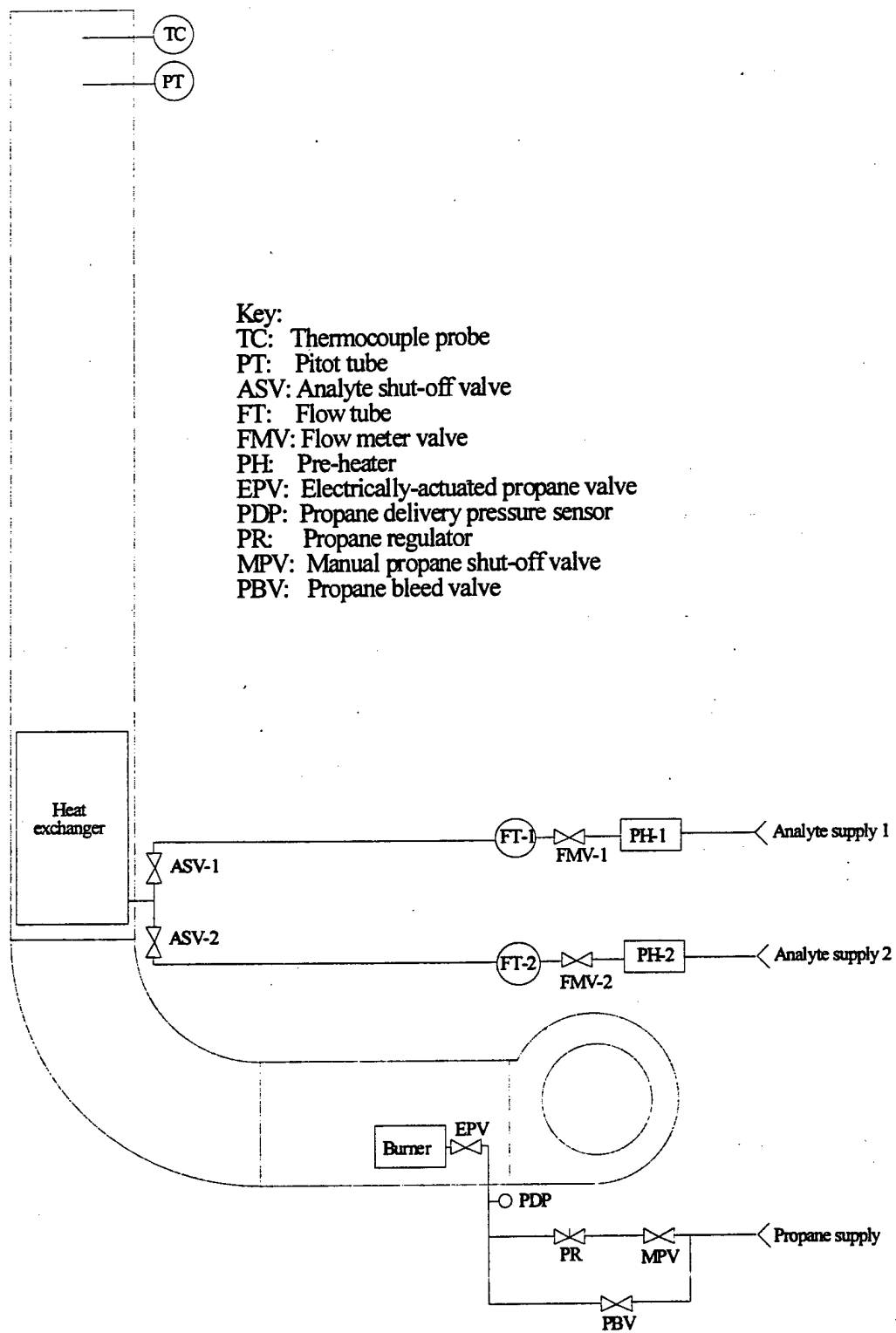

Figure 7. Analyte flow diagram for the plume generator.

Supplemental Collection 1 - 970805 - Ammonia

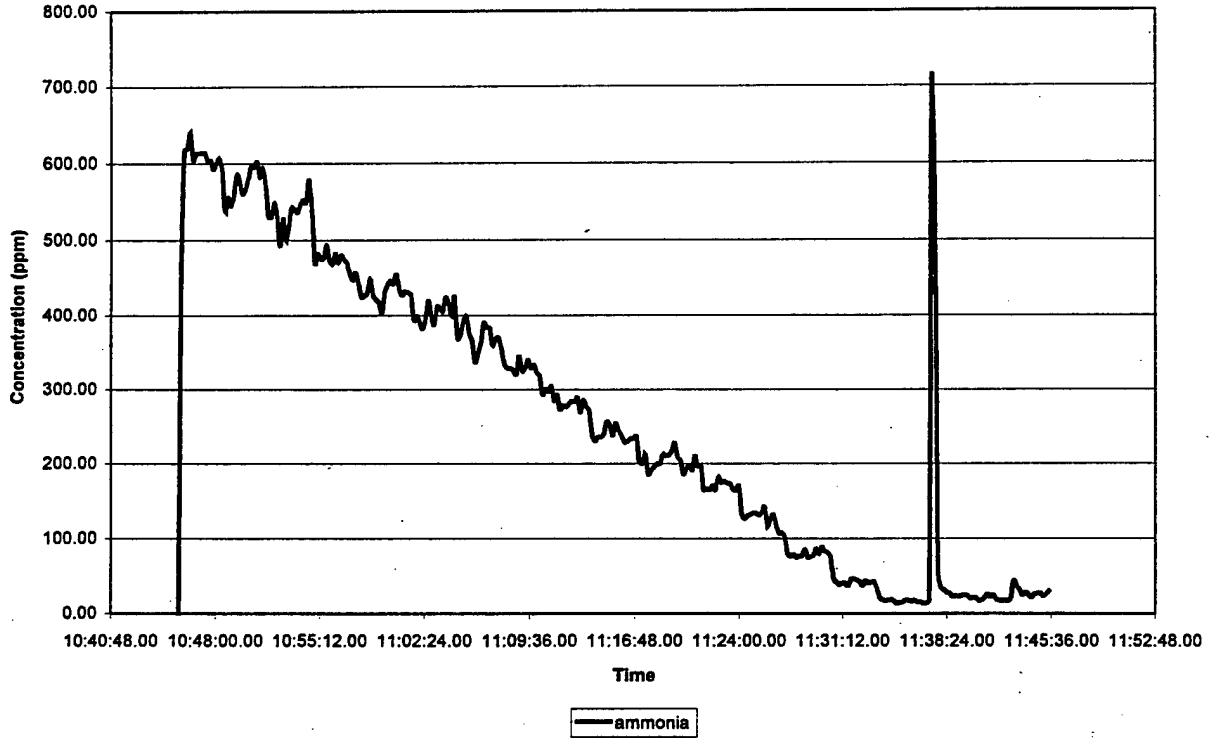

Figure 8. Ammonia levels in plume during release example cited in text.

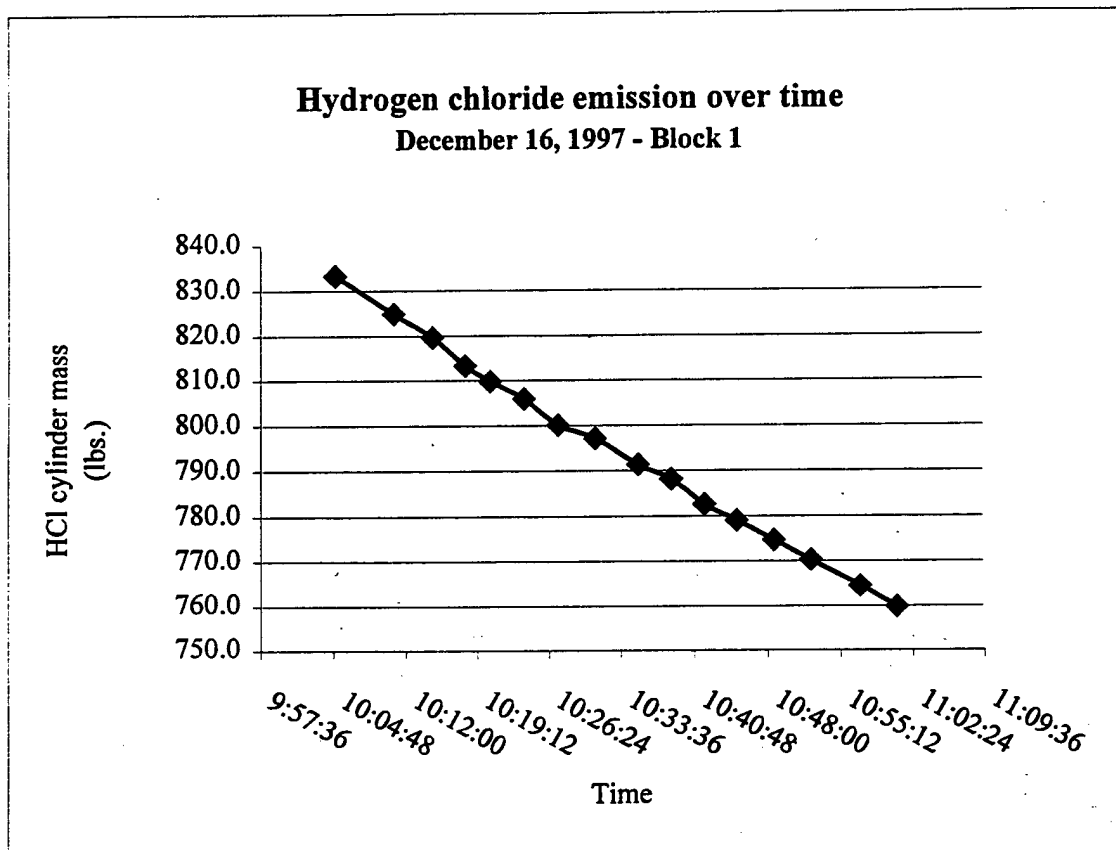

Figure 9. Plot of mass lost in hydrogen chloride cylinders during a typical release using direct introduction into the heat exchanger assembly, bypassing the flow meters.

Table 1.
Major structural and functional components of the plume generator.

Component/ Feature	Specifications	Comments
Overall power requirements	<10 amps, 120 VAC	
Centrifugal blower	3000 cfm nominal	
Blower motor	¾ hp, single phase	
Propane burner	Maximum output: 2.5 Mbtu/hr	~1 lb./min = 2000 cfm at 200 C
Propane regulator	Single stage liquid propane 3 – 35 psig delivery pressure	0 – 60 psig gauge on outlet
Stack tube	18 Ga. galvanized spiral wrap pipe	Readily available, inexpensive to replace and modify as necessary

Table 2.
Plume generator instrumentation and specifications.

Component/ Feature	Specifications	Comments
Temperature probe	Type J thermocouple -190° C– 871° C range 12" x 0.1875" SS probe	Positioned in the center of the stack tube, top of stack
Temperature panel meter	-200.0° C– 760.0° C range 4 ½ digit, 1/16 DIN	Digital
Stack air flow probe	¼" O.D. x 12" Pitot tube	Positioned in the center of the stack tube, top of stack
Stack air flow meter	Range: 0" – 0.5" w.c. Resolution: 0.01" w.c	Analog differential pressure gauge Typical reading: 0.20" w.c.
Analyte flow meters	150-mm glass flowtubes Glass, stainless steel, Carbaloy, and tantalum floats	Variable area type Able to handle corrosives Provide good precision

Table 3.
Plume generator performance capabilities.

Performance characteristic	Minimum	Maximum	Control precision	Monitoring accuracy
Volumetric air flow	500 cfm	2000 cfm	± 10%	± 10%
Temperature	Ambient	300° C	± 5° C	± 2° C
Emission rate through flow meters	10% turn-down ratio	Gases: 0 – 65 LPM Liquids: 0 – 2 LPM	± 2%	± 1% F.S.
Emission rate with direct introduction/direct mass measurement	0	Determined by cylinder pressure and regulator flow characteristics	± 5%	± 1%

Table 4.
Plume generator operational log for an ammonia release.

August 5, 1997 – Supplemental Release #1 Stepped ammonia releases at 200 C (moderate concentrations)						
Time ¹	Release condition	Analyte	Stack temperature	Stack air flow (SCFM)	Flow tube - Flow rate	Emission rate ² (lb./min.)
~10:46:00	1	NH ₃	197	1551	40G - 150	0.047
10:48:30	2	NH ₃	198	1526	40G - 140	<i>0.044</i>
10:51:40	3	NH ₃	198	1503	40G - 130	<i>0.041</i>
10:54:40	4	NH ₃	199	1501	40G - 120	<i>0.038</i>
10:57:50	5	NH ₃	199	1547	40G - 110	<i>0.034</i>
11:01:40	6	NH ₃	199	1547	40G - 100	0.031
11:04:40	7	NH ₃	199	1524	40G - 90	<i>0.028</i>
11:07:50	8	NH ₃	202	1520	40G - 80	<i>0.025</i>
11:11:00	9	NH ₃	198	1526	40G - 70	<i>0.022</i>
11:14:00	10	NH ₃	197	1528	40G - 60	<i>0.019</i>
11:17:10	11	NH ₃	195	1554	40G - 50	<i>0.016</i>
11:21:30	12	NH ₃	197	1528	40G - 40	<i>0.013</i>
11:24:15	13	NH ₃	198	1526	40G - 30	<i>0.009</i>
11:27:20	14	NH ₃	198	1526	40G - 20	<i>0.006</i>
11:30:30	15	NH ₃	200	1568	40G - 10	<i>0.003</i>

1. The times in column 1 correspond to the time at which the plume generator was adjusted to the settings listed in the same row as the time.
2. Emission rates in bold are from calibration trials as described elsewhere in this document. Emission rates in italicized type are interpolated values, using the maximum rate and zero as the boundary points for the interpolation.

Table 5.
Flow tube calibration data relevant to the ammonia release example cited in the text.

Flow tube and float material	Setting	Analyte	Flow time (min:sec)	Beginning weight (lb.)	End weight (lb.)	Flow rate (lb./min)	Uncertainty
40G	150	NH ₃	21:28	102.15	101.15	0.047	5.0%
40G	100	NH ₃	41:58	101.00	99.70	0.031	3.8%

Appendix A
Characterizing the plume generator's volumetric output

When combined with knowledge of the stack's internal flow characteristics, air velocity data collected near the stack exit can be correlated to volumetric output in terms of cubic feet per minute. A series of air velocity measurements have been performed to characterize the stack's internal flow characteristics.

The Pitot tube and gauge normally used to monitor the air velocity at the center of the stack have been used to make similar repeated air velocity measurements at regular intervals along perpendicular diameters near the stack exit. See the figure below.

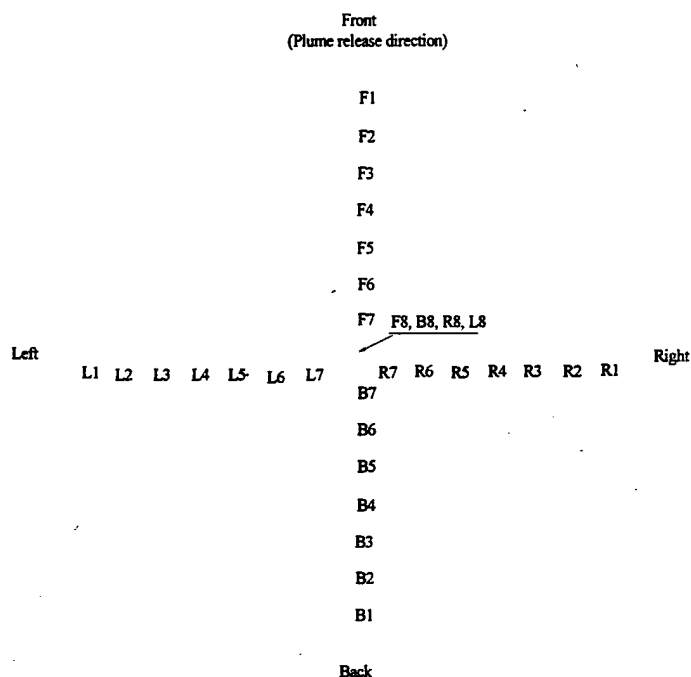

Air flow data

	Front	Back	Right	Left	Ave.
1	1500	1350	1200	1575	1406.25
2	1600	1450	1350	1675	1556.25
3	1600	1575	1500	1750	1606.25
4	1625	1625	1700	1800	1687.50
5	1750	1725	1750	1800	1756.25
6	1850	1800	1900	1800	1837.50
7	1875	1850	1950	1850	1881.25
8	1925	1925	1900	1875	1906.25

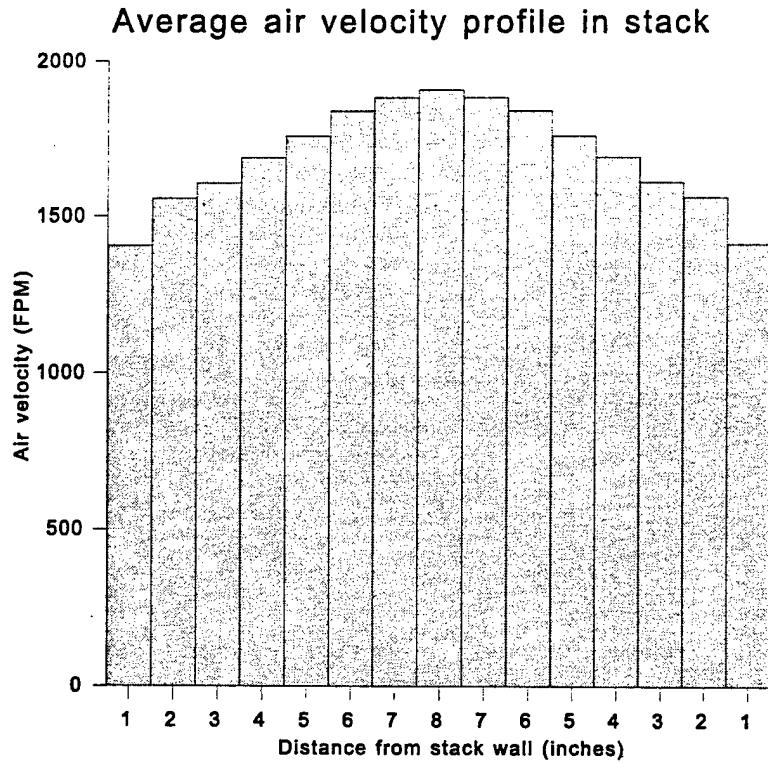

The average air velocity data corresponding to different areas within the stack are plotted above. These data have been used to calculate the average area-weighted air velocity across the entire stack, which is approximately 84% of the value collected at the center of the stack. The stack's cross-sectional area is 1.4 ft². Volumetric output can therefore be calculated directly from the gauge reading with the following formula:

$$\begin{aligned} \text{Volumetric output in CFM} &= (\text{center air velocity in FPM})(1.4 \text{ ft}^2)(0.84) \\ &= 1.2 (\text{center air velocity in FPM}) \end{aligned}$$

Appendix B

Standard Safe Operating Procedures for the AeroSurvey M-series Plume Generator

I. Set-up

- A. Position the trailer in the desired release location.
- B. Install the in-stack sensors prior to installation of vertical stack on plume generator.
- C. Install vertical stack tube on base, chain to support mast.
- D. Connect analyte feed line between plume generator base and stack tube.
- E. Position propane tank.
- F. Connect flexible propane feed line from propane tank to propane inlet on plume generator.
- G. Position analyte scales, plug into power strip on the plume generator.
- H. For gaseous analytes:
 - 1. Erect cylinder safety stand around scales.
 - 2. Load analyte cylinder on scales, remove cap and any plugs.
 - 3. Tie cylinder to safety stand.
 - 4. Install analyte cylinder regulator.
 - 5. Connect flexible line between regulator and analyte pre-heater input on plume generator.
- I. For liquid analytes:
 - 1. Position analyte vessel on scales.
 - 2. Install dip tube between analyte vessel and liquid pump inlet.
 - 3. Connect pump outlet to analyte pre-heater input on plume generator.
- J. Verify that all circuit breakers and panel switches are in the "off" position (down).
- K. Connect the device's power cord to a source of 120 VAC power.
- L. Flip all circuit breakers to the "on" position (up position).

II. Start-up

- A. At the control panel, switch on the blower and the electrically-actuated propane shut-off valve.
- B. Verify that the red manual shut-off valve for the propane is in the "off" position.
- C. Open the valve at the propane tank to charge the line to the plume generator.
- D. Charge the propane line with liquid propane:
 - Turn the red propane shut-off valve at inlet to the open position. Propane should begin flowing through the generator but will not ignite. Allow the propane to flow for approximately 15 seconds, then close the valve. Wait for 15 seconds before attempting to fire the burner.
- E. Fire the burner:
 - Open the cover on the combustion plenum. Insert the tip of a piezo spark igniter into the burner cylinder from the rear. Open the propane bleed circuit while clicking the spark igniter. When the burner fires, close the cover on the combustion plenum and turn the red propane valve to the full on position.
- F. Verify operation of the temperature and stack air flow sensors.

III. Operation

In general, the burner and blower should be left on continuously unless no activity is expected for at least two hours. (The propane delivery pressure may be turned down during short periods of inactivity.) Analyte flow and burner adjustments may be made while the burner and blower are running. Analyte sources may be switched while the burner and blower are running.

The plume generator may also be slightly re-positioned in the field while the burner and blower are running but care should be taken with regard to analyte and propane lines. For such re-positioning activities, a person (in addition to the person moving the plume generator) should be assigned to monitor the propane and analyte lines coming onto the plume generator during the movement.

A. Changing the plume temperature:

Adjusting the propane delivery pressure with the propane regulator changes the plume temperature. (There should be no regulator at the propane tank.) A delivery pressure of 2-3 psi should be the minimum used during low-temperature releases, idle periods, and re-positioning of the plume generator.

B. Charging and operation with gaseous analytes:

1. Verify that the flow meter valve is in the full "on" position.
2. Verify that the regulator delivery pressure knob is backed off (to initially deliver zero pressure).
3. Verify that the regulator output valve is in the full "off" position.
4. Open the analyte cylinder to the regulator.
5. Open the regulator output valve.
6. Adjust the regulator delivery pressure while watching the flow meter. Increase delivery pressure until the flow meter float slightly exceeds the maximum flow reading.
7. Adjust to the desired flow with the flow meter valve.
8. Verify pre-heater set point and then turn on the pre-heater with the panel switch.
9. Shut off gaseous flow completely with the regulator output valve.

C. Charging and operation with liquid analytes:

1. Verify that the flow meter valve is in the full "on" position.
2. Turn on the liquid pump with the panel switch.
3. Allow the pump to fully charge the flow meter.
4. Adjust to the desired flow rate with the flow meter valve.
7. Verify the pre-heater set point and then turn on the pre-heater with the panel switch.

D. Changing a gaseous analyte cylinder:

1. Turn the analyte off at the cylinder valve and wait for the line pressure to drop.
2. Remove the regulator and disconnect the cylinder from the safety stand
3. Replace the cylinder plug and cylinder cap and remove the cylinder from scales.
4. Re-zero the scales as necessary.
5. Repeat procedure for setting up a gaseous analyte.
6. Repeat procedure for charging the analytes lines with a gaseous analyte.

E. Changing a liquid analyte vessel:

1. Turn off the liquid pump.
2. Remove the liquid analyte vessel from the scales, cap and secure as necessary.
3. Re-zero the scales as necessary.
4. Place the new liquid analyte source on the scales
5. Open the new liquid analyte vessel and place the dip tube in it.

Note: If desired, empty liquid vessels may be replenished from full vessels of the same analyte without need to shut down any part of the plume generator operation.

IV. Shut-down

A. For short-term shut-down (1-3 hours):

1. Turn off all analytes.
2. Flush lines with nitrogen gas or water if desired.
3. Shut the propane off at the red manual shut-off valve.
4. Allow propane to burn out of the line. Leave blower running for at least 10 minutes after flame is extinguished.
5. Shut off the electrically actuated propane valve from the control panel.
6. Shut off the blower and all other panel-switched devices.

B. For long-term or overnight shut-down:

1. Turn off all analytes.
2. Flush lines with nitrogen gas or water if desired.
3. Turn the propane off at the propane tank valve.
4. Allow propane to burn out of line. Leave the blower running for at least 10 minutes after flame is extinguished.
5. Shut off the electrically actuated propane valve from the control panel.
6. Shut off the blower and all other panel-switched devices.
7. Shut off all circuit breakers.
8. Disconnect the power cord from the power source.
9. Disconnect the propane feed line from the plume generator for permanent shut-down or if desired for overnight shut-down.

V. Emergency Shut-down

A. Due to fire or propane leak:

1. Direct or have someone assigned to shut off the propane at the tank.
2. Shut off the propane first at the red manual shut-off valve and then at the electrically-actuated valve.
3. Leave the blower running unless fire conditions appear to be exacerbated by it.
4. Shut off any gaseous analytes at the cylinder.
5. Shut off any liquid analytes by powering down the pump.
6. Remove any combustible analytes from the area if possible.

B. Due to an electrical problem or uncharacterized situation:

1. Direct or have someone assigned to kill power to the plume generator if possible. (Pull the plug.) Otherwise, flip all circuit breakers to the "off" position.
2. Shut off any gaseous analytes at the cylinder if possible.
3. Direct or have someone assigned to shut off propane at the tank if necessary.