

291096

JPRS 81662

30 August 1982

Approved for public release  
unless otherwise indicated

# China Report

SCIENCE AND TECHNOLOGY

No. 172

19980917 075

**FBIS** FOREIGN BROADCAST INFORMATION SERVICE

REPRODUCED BY  
NATIONAL TECHNICAL  
INFORMATION SERVICE  
U.S. DEPARTMENT OF COMMERCE  
SPRINGFIELD, VA. 22161

8  
35  
103

#### NOTE

JPRS publications contain information primarily from foreign newspapers, periodicals and books, but also from news agency transmissions and broadcasts. Materials from foreign-language sources are translated; those from English-language sources are transcribed or reprinted, with the original phrasing and other characteristics retained.

Headlines, editorial reports, and material enclosed in brackets [] are supplied by JPRS. Processing indicators such as [Text] or [Excerpt] in the first line of each item, or following the last line of a brief, indicate how the original information was processed. Where no processing indicator is given, the information was summarized or extracted.

Unfamiliar names rendered phonetically or transliterated are enclosed in parentheses. Words or names preceded by a question mark and enclosed in parentheses were not clear in the original but have been supplied as appropriate in context. Other unattributed parenthetical notes within the body of an item originate with the source. Times within items are as given by source.

The contents of this publication in no way represent the policies, views or attitudes of the U.S. Government.

#### PROCUREMENT OF PUBLICATIONS

JPRS publications may be ordered from the National Technical Information Service, Springfield, Virginia 22161. In ordering, it is recommended that the JPRS number, title, date and author, if applicable, of publication be cited.

Current JPRS publications are announced in Government Reports Announcements issued semi-monthly by the National Technical Information Service, and are listed in the Monthly Catalog of U.S. Government Publications issued by the Superintendent of Documents, U.S. Government Printing Office, Washington, D.C. 20402.

Correspondence pertaining to matters other than procurement may be addressed to Joint Publications Research Service, 1000 North Glebe Road, Arlington, Virginia 22201.

CHINA REPORT  
SCIENCE AND TECHNOLOGY

No. 172

CONTENTS

PEOPLE'S REPUBLIC OF CHINA

APPLIED SCIENCES

Development of New Electronic Products Reported (Wei Yong; DIANZI KEXUE JISHU, No 2, 1982) .....	1
Sino-West German Symposium Held on Astrophysics (Mao Rongfang; GUANGMING RIBAO, 18 Apr 82) .....	3
Advantages of Rocket-Delivered Anti-Tank Mines Discussed (Hua Shan; HANGKONG ZHISHI, Jul 82) .....	4
Aerospatiale Dauphin 2 Aerobatics Exhibition Dazzles Onlookers (Xie Chu; HANGKONG ZHISHI, Jul 82) .....	8
National Aerotechnology Import-Export Corporation Expands Business Base (Hang Yan; HANGKONG ZHISHI, Jul 82) .....	14
Plans for Mechanics Society's Academic Activities Announced (LIXUE YU SHIJIAN, No 2, 1982) .....	16
Conference on Machinery Heat Treatments Held (JINSHU RECHULI, No 4, 1982) .....	19
Development of Directional Solidification Technology in China (Xue Yanlu; GUOJI HANGKONG, May 82) .....	20

ABSTRACTS

ENGINEERING THERMOPHYSICS

GONGCHENG REWULI XUEBAO [JOURNAL OF ENGINEERING THERMOPHYSICS], No 4, Nov 81 .....	30
---	----

## APPLIED SCIENCES

### DEVELOPMENT OF NEW ELECTRONIC PRODUCTS REPORTED

Beijing DIANZI KEXUE JISHU [ELECTRONIC SCIENCE & TECHNOLOGY] in Chinese No 4, 1982 p 48

[Report by Wei Yong [3634 3938]: "Brief Reports on Technology"]

[Text] RGS Series Heat Pipe Radiator Apprasied for Production

With the cooperation of the Xian Power Supply Society and the state-run Plant No 877, the Xian Municipal Electronic Instrument Plant successfully developed an RGS-Z series self-cooled heat pipe radiator and an RGS-F wind-cooled heat pipe radiator, which passed technical appraisal in December 1981. At present, heat pipe radiators of two series and over 10 types of specifications (50-1000W) are being batch processed.

The heat pipe is a highly efficient heat-conducting component that appeared in the 1960's and is known as a "near superconductor." A heat pipe radiator is composed of a heat pipe and radiator fins. The heat pipe is itself a near super heat-conducting vacuum device. Its working principle is this: a sealed tube vacuum container is filled with a definite amount of liquid-state working mass, and relying on the process of phase variation it uses the evaporation of latent heat to quickly transmit thermal capacity. Therefore, heat pipe radiators have excellent heat conductivity. They have a high efficiency of heat conduction (heat transmission coefficient is several thousand times that of silver) and a good axial isothermal quality. Consequently they are extensively used.

The heat pipe radiator developed by the Xian Municipal Electronic Instrument Plant is rationally designed and its technical conditions conform to the standard requirements of the defense industry. It has a leading place in the country and can be used as a radiator for high-power crystal tubes, rectifier tubes and silicon controlled rectifiers. In accord with consumer demands, the plant can also supply various types of heat pipes as radiators in sealed mechanical cabinets and transformers or as isothermal devices.

Heat pipe radiators have the advantages of small size, light weight, high efficiency in heat radiation and reliability. They can replace water-cooled units used in electronic equipment and can greatly reduce the size and weight of equipment, while increasing reliability. If used in conjunction with the

high-efficiency heat-conducting grease developed by the Beijing Material Research Institute of the No 7 Machine Department, the result will be even greater.

The Xian Electronic Instrument Plant can directly supply consumers with heat pipe radiators of different specifications. The plant address is: Xiaobeimen wei, Xian Municipality, telephone 6-1823, cable 1823.

#### SB802 Semiconductor Component Parameters Quick-Testing Instrument

This instrument, which was recently successfully trial-produced by the Shanghai Shanghai Meter Plant, is a new and popular type of semiconductor component parameters multiple quick-testing instrument.

This instrument uses the methods of circuit tests and direct sampling display tests, which can make quick circuit tests of each parameter of the instrument being tested and can simultaneously display all parameters on a fluorescent screen through one scan by the oscilloscope. Test measurement range and test conditions of the instrument are determined by different test inserted parts. It can be used for various parameters of measurement transistors, TTL, CMOS and PMOS integrated circuits and operational amplifiers, with less than 5 percent error. Besides, the instrument has the function of making fixed-point static tests and schematic characteristic curves for each parameter. Equipped with accessories, it can also make quick manual, step and automatic-step tests.

#### PTV Infrared Heat Television Passes Appraisal Test

The PTV infrared heat television, which was developed by the Huabei Electric Power Test Research Institute with the use of the thermal power-releasing camera tube produced by the No 1431 Section of the No 4 machine Department, passed the appraisal test in November 1981. It can quickly and directly display the distribution of surface temperature of a piece of equipment and present a digital display of the temperature of overheated spots. On-the-spot and actual use has proved that it can quickly and visually check and test the trouble of overheating, which basically satisfies on-site needs and contributes to safe generation and supply of power.

Compared to the traditional optical-mechanical scanning thermal imaging system, the infrared heat television has the advantages of requiring no liquid nitrogen refrigeration, low price, being usable in any position and convenient for large batch processing.

Besides its use for a power system, PTV infrared heat television can also be used for energy economization, detection of fire sources, testing laser beams, night vision in battlefield, harmless injury detection and other purposes.

9586

CSO: 4008/168

APPLIED SCIENCES

SINO-WEST GERMAN SYMPOSIUM HELD ON ASTROPHYSICS

Beijing GUANGMING RIBAO in Chinese 18 Apr 82 p 1

[Report by Mao Rongfang [3029 2837 2455]: "Sino-West German Symposium on High Energy Astrophysics Concludes in Nanjing"]

[Text] The 9-day symposium on high energy astrophysics held by the Chinese Academy of Sciences and the Max Planck Society of West Germany ended satisfactorily in Nanking on 17 April. Through mutual contact and academic exchanges, Chinese and foreign scientists have deepened their understanding and enhanced their friendship.

The exchanges in this symposium were rich in substance, including research on neutron stars and other orders of stars, as well as exploration in the areas of galaxies and cosmology. Reports and papers presented at the conference clearly showed that the level of this academic conference was relatively high. West German scientists conducted painstaking theoretical research on close binary stars, catastrophic binary stars and supernovas. They presented information to the scientists present at the conference on the theory on the accretion of neutron stars. Application of this theory can more satisfactorily explain the phenomena of the radiation of pulsars.

In recent years our scientists have launched research on quasi-stellar objects, active galactic nuclei and compact bodies, accomplished new work in the field of large-scale cosmological structure, and applied the theory of neutrinos having static mass to astronomical research.

The conference received a total of 20 academic papers, and 17 commentary reports were presented. During the period of the conference Chinese and foreign scientists enthusiastically visited the Zijinshan Observatory and the solar tower of the Astronomy Department at Nanjing University.

9586

CSO: 4008/168

## APPLIED SCIENCES

### ADVANTAGES OF ROCKET-DELIVERED ANTI-TANK MINES DISCUSSED

Beijing HANGKONG ZHISHI [AEROSPACE KNOWLEDGE MAGAZINE] in Chinese No 7, Jul 82, pp 30-31

[Article by Hua Shan [5478 1472] "Mine-laying Rocket"]

[Text] During a military exercise in northern China last year, waves of missile-like rockets were launched, but they were not ordinary missiles. When they reached a certain point in the air, a series of cylindrical objects were released from the warhead. Under the action of speed-reduction devices, they gradually descended toward the earth, spreading uniformly over a specified area. These were mine-laying rockets, and the cylindrical objects were anti-tank land mines. Once reaching the ground, the mines formed an anti-tank field, which deters the offenses of enemy tanks. Because of the unique features of this exercise, it received considerable attention, and was reported in foreign journals and newspapers.

#### Why Mine-Laying Rockets?

To understand the importance of mine-laying rockets, let us first discuss tanks and tank warfare. After the Second World War, some countries predicted that the success of future battles would depend on mobility, speed, and rapid adjustment to battle conditions. Battles would be conducted on wide open fields where tanks are the ideal weapons. The tank is a striking force with intense fire-power, high mobility, and heavy armor. In an offensive movement, it is often the focal point for penetrating enemy lines and driving swiftly deep into enemy territory. In a nuclear battle, tanks can move through contaminated areas. Therefore, the tank has become an important weapon for ground forces to control the battlefield. At present, many countries not only are aggressively developing new tanks, but also have accumulated a stockpile of tanks which more than exceed their defense needs. Consequently, a key issue in winning future battles is how to eliminate enemy tanks in a timely manner.

The traditional weapons for defending against tanks are tanks, anti-tank guns, land mines, and missiles. Anti-tank missiles and guns are highly accurate weapons, but they are inadequate against a large-scale attack. In a large-scale attack, the key is to disable part of the tanks before they reach the battlefield, and to deter the offensive speed, so that there would be enough

time to coordinate all the anti-tank weapons to destroy enemy tanks. The land mine is an effective weapon against tanks; 20 percent of the tanks during the Second World War and 70 percent of the tanks on the battlefields of Korea were destroyed by land mines. But in a modern battle, deploying the mines prior to the battle is no longer appropriate; they must be deployed on a large scale according to the battle conditions and with great speed. There are several methods of rapid mine deployment; by rockets or missiles, by guns, or by aircraft (including helicopters, see the March 1982 issue of this journal).

#### Advantages of Using Rockets for Mine Laying

The advantages of using rockets to lay mines are as follows: 1) high speed--usually a minefield can be set up in just a few minutes, compared to tens of hours or even days by conventional manual methods; 2) high mobility--it is not constrained by terrain conditions, therefore, more opportunities will be available; 3) it can deploy mines deep behind enemy lines, in regions of concentrated enemy firepower, or in regions contaminated by a nuclear explosion; 4) it can rapidly deploy mines along tank routes to intercept enemy tanks and delay their advances; 5) it can be used to confine enemy tanks in a restricted area so they may be destroyed by other anti-tank weapons; in this sense it is not only a defensive weapon but also an effective offensive weapon; 6) since the mines are deployed after the enemy tanks have been committed along their attack routes, not only does the minefield become more effective, but the size of the minefield and the number of mines are reduced compared to conventional minefields, which must cover all possible routes of attack; 7) laying mines using rockets is more economical and safer than using aircraft; and 8) in defense against a large-scale tank attack, it is the most cost effective of all anti-tank weapons.

The disadvantage of rocket mine-laying (which is common to all rapid mine-laying techniques) is that the mines are scattered on the surface and therefore easy to discover and remove. Therefore, anti-tank mines should be deployed in conjunction with anti-infantry mines to produce a mixed mine field, or they should be equipped with time fuses to increase their effectiveness.

#### Components of a Mine-Laying Rocket

The mine-laying rocket has been part of the weapon development plan of many countries since the 60's; by the 70's, most West European countries had developed new rockets and multi-barrel rocket guns for deploying anti-tank mines and matching equipment. Also some countries had equipped their missiles with "mine-laying" warheads. The U.S. "Lance" missile was one of them.

The mines to be deployed by rockets, missiles, cannons, or airplanes must satisfy certain requirements. To meet the requirements of rapid deployment, a new type of mine called the "scattering mine" has been developed. It is powerful, lightweight, small in size, and has a self-destruction mechanism; some are even equipped with an anti-removal device. Its weight varies between 1.5 and 2.5 kg; its diameter is approximately 100 mm, and its length varies

between 300 and 400 mm. It is equipped with powerful explosives, and employs magnetic or sound fusing devices or a pressure trigger fuse for ignition. It can penetrate the treads and bottom armor of a tank; it can also kill the tank crew and set the tank on fire.

In conjunction with the scattering mines, two kinds of rocket cannons and associated rockets were developed. The first kind is a 110 mm 36-barrel light rocket cannon; its range is between 10 and 15 km, and it is primarily used by troops. The rocket weighs approximately 37 kg, and has a 15 kg warhead, which can carry 8 to 10 scattering mines, with a total scattering area of 0.025 square kilometer. The second kind is a medium-size rocket cannon with a range of approximately 40 to 60 km, and is primarily used for regional defense. The rocket weighs approximately 600 kg; its warhead weighs 200 kg, and carries 70 to 80 scattering mines, with a total scattering area of approximately 0.25 square kilometer.

The rocket used by either the light-weight or medium-size cannon has essentially the same structure; it consists of a warhead and a rocket engine. The number of scattering mines contained in a warhead varies depending on the capacity of the warhead and the size of the mines. At the base of the warhead is an electric time fuse and ejector. At a certain time after launch, the electric fuse is activated, detonating an explosive charge that breaks open the warhead shell; at the same time, the mines are ejected and the parachutes are opened. As the mine descends, the tension on the parachute chords pulls the sliding sleeve upward, exposing the spring-loaded spiral fins inside. Stabilized by the action of the parachute and the tail fins, the mine descends until it plunges into the ground, as shown in Fig 1. When a tank passes over or next to the mine, the non-trigger fuse is activated, igniting the explosives. This generates a high temperature, high pressure jet stream which penetrates the armored plate on the bottom of the tank or damages the treads.

Fig.1 Schematic Diagram Showing the Structure of a Scattering Mine

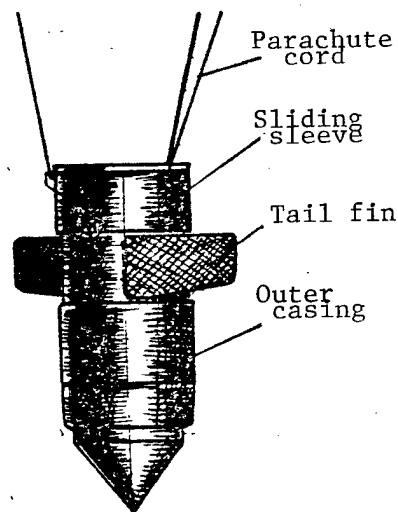

图一 可散布地雷的结构示意图

In conclusion, we must point out that while rapid deployment of mines by rockets has many advantages, it cannot completely replace other methods of mine-laying, including manual and mechanical means. Also, scattering mines cannot take the place of other types of mines, or other anti-tank weapons. The effectiveness of land mines can be fully realized only if they are used in conjunction with other anti-tank weapons.

3012

CSO: 4008/203

## APPLIED SCIENCES

### AEROSPATIALE DAUPHIN 2 AEROBATICS EXHIBITION DAZZLES ONLOOKERS

Beijing HANGKONG ZHISHI [AEROSPACE KNOWLEDGE MAGAZINE] in Chinese No 7, Jul 82  
pp 2-4

[Article\* by Xie Chu [6200 4342] "The SA 365N Dauphine 2 Helicopter"]

[Text] On the morning of 6 February, at the invitation of the Chinese Aerotechnology Import-Export Corporation (see article on p 7 of this issue), we drove to the Capital Airport to see a flight demonstration of the Dauphin 2 helicopter.

The Dauphin 2 helicopter is a product of the French Aerospatiale Company in the late 1970's; its French model number is SA 365N. It is a twin-engine, medium-size jet helicopter which has a wide range of applications. It received the French aviation certification in 1981. The helicopter was developed by the Helicopter Subsidiary of the French Aerospatiale Company, which incorporated many new technologies of the late 70's. Therefore it is representative of the current state-of-art in helicopter technology, and its performance is considered to be superior among similar products on the world market.

#### Adaptation of Dauphin Manufacturing Technologies

Two years ago, this reporter learned that the Chinese Aerotechnology Import-Export Corporation (CAIEC) was considering adapting a new helicopter manufacturing technique from abroad. The company conducted an investigation in which detailed analyses and comparisons of some of the more advanced helicopters in the world were made; they also sent delegations to various helicopter manufactureres in the United States and France. As a result of this investigation the Dauphin 2 was selected. In July 1980, CAIEC signed a contract with the French Aerospatiale Company to transfer the Dauphin 2 manufacturing technology. The contract specified that France would transfer all technologies required to build this helicopter and its engines to China. Initially, France would provide two complete helicopters to be assembled in China; then France would supply only some of the parts, and finally all the parts for the helicopter and the engines would be built and assembled in China. During this period

\* For additional material on the SA 365N Dauphin 2, see JPRS 81180, China Report/Science and Technology, No 165, 30 Jun 82, pp 23-28

of cooperation, France would help Chinese technicians master all the necessary techniques for building the helicopter as well as the engine. The two parties also agreed that China would sell a certain quantity of helicopter parts back to France as partial compensation for the technology transfer. This contract was approved by both governments and became effective in 1980.

The Dauphin 2 received considerable attention because it was the first adaptation of foreign helicopter technology in 20 years--since the M-4 helicopter in the 50's. With the help of a comrade who participated in the helicopter inspection and selection process, this reporter was allowed after signing of the contract to read all the pertinent information in order to understand the reasons behind the selection and the characteristics of this helicopter. In addition to the written information, now he was given the opportunity to see the helicopter in person. Upon arrival at the Capital Airport, we were taken to a lounge where Chinese and foreign guests attended an introductory briefing and watched a French movie about the Dauphin helicopter. According to this introduction, the Dauphin 2 is a multi-purpose helicopter. By adapting more than 50 selected pieces of equipment, the French Aerospatiale Helicopter Company can modify the basic helicopter into different models for different applications. For example, it can be used to transport personnel between the mainland and off-shore oil drilling platforms; it can be used for geological exploration, aerial photography, forest fire prevention, field rescue, installation of high voltage power lines, and coastal patrol; it can also be used to serve as a short-range passenger carrier along a route where ground transportation is not readily available. In addition, the French Aerospatiale Company is developing a military model of the Dauphin helicopter which will serve as an anti-tank vehicle or troop carrier, and perform such functions as reconnaissance, ranging, and ship-based operations. Because the rotor blades of the Dauphin are made of corrosion-resistant composite materials, it is particularly suitable for applications at sea.

After the movie, all the guests were invited to the airfield to see the flight demonstration.

#### Flight Demonstration of the Dauphin Helicopter

A strong wind was blowing on the airfield, but the flight demonstration proceeded as scheduled. There was a large number of spectators, including many guests from France: the French ambassador, the chairman of the French National Bureau of Aviation, and the president of the French Aerospatiale company.

Glittering under the sun was a streamlined helicopter painted in white with red and blue stripes. Unlike conventional helicopters, its tail rotor is embedded inside the large vertical tail. This type of culvert tail rotor design not only eliminates the need for an intermediate speed reduction unit, but also provides additional safety. During ground operation or low-altitude flight, the pilot need not worry about the rotor blades injuring people or hitting trees.

An accident caused by a tail rotor happened on 2 March of last year, when an Mi-8 helicopter of the Egyptian Air Force developed engine trouble during take-off, and the tail rotor caught a dangling power line. The helicopter

immediately went out of control and hit a pole nearby; it fell to the ground and burned, killing all passengers on board, including the Minister of Defense and more than ten high-ranking military officers.

The cockpit and passenger cabin of the Dauphin have large windows which provide good visibility. On top of the fuselage are two "Arriel" 1C turbo-axle engines. This engine was developed in the late 70's; it is light-weight, compact, and has relatively low fuel consumption. Each engine can deliver up to 700 hp.

The Dauphin helicopter used in the flight demonstration was the first complete helicopter received from France. It was first flight-tested and certified in France, and then disassembled for shipping to this country. It was then re-assembled in Beijing to take part in the flight demonstration. The flight crew of today's demonstration consisted of both Chinese and French pilots. The pilot and the engineer were French and the co-pilot was Chinese.

At 9:30 am, the ground commander issued a start signal. Accompanied by the roaring sound of the engines, the four rotor blades began to rotate rapidly. Supported by its tricycle landing gear, the Dauphin glided over the runway, and then lifted off. First it climbed rapidly, then it dove in front of the review stand and cruised by at an altitude of only 50 meters. With the landing gear retracted, the helicopter has a clean, aerodynamic shape with very low air resistance. Because of the low-drag aerodynamic design and light structural weight, the Dauphin 2 can reach a maximum cruising speed of 293 km per hour. This is 10 to 20 percent faster than similar jet-propelled helicopters such as the U.S. Bell 212/412; and 30 to 40 percent faster than piston engine helicopters such as the Soviet M-4.

Right before us, the Dauphin climbed upward along a steep slope, then turned into a dive (maximum speed during a dive can reach 324 km/hr), and passed over our heads. Again, it climbed upward and made a turn before it slowed down and hovered in midair. While hovering, it was able to move sideways to the left and to the right, and also rotate rapidly in the same spot. Suddenly, it started to climb vertically to an altitude of 400 m; then it dove straight down, and as the spectators whispered with awe, it glided sideways and landed on the runway.

Although the demonstration only lasted for a short time, the spectators were able to observe 20 to 30 different flight maneuvers. The smoothness of these maneuvers clearly demonstrated the high degree of mobility of a modern helicopter.

#### Successful Application of Composite Materials

After the demonstration, we all approached the helicopter and gave our congratulations to the pilots who were emerging from the exist door. They opened all the doors to the cockpit and the passenger cabin for us to inspect the interior of the helicopter. The main body of the Dauphin helicopter makes extensive use of composite materials; 59 percent of its structure is made of composite materials whereas ordinary aluminum alloy riveted structures account for only 13 percent. As a result of extensive weight reduction measures and improved design efficiency, the take-off weight of the helicopter is only

3,850 kg, but its effective payload can be as high as 1,810 kg. In comparison, the M-4 has approximately the same effective payload, but its maximum take-off weight is almost twice as large. According to the reporter's observation, the Dauphin is only two-thirds the size of the M-4, but the capacities of the two cabins is approximately the same. In addition to the two pilots, the Dauphin can accommodate 12 passengers; also, there is a luggage room in the rear. According to the pilot, because of its light weight and small drag area, the Dauphin is not only fast but also economical. The fuel consumption of the Dauphin is approximately 1 kg per km; the U.S. Bell 212/412 helicopter consumes approximately 1.5 kg per km. The pilot is also satisfied with the control of the helicopter. Although the control system is rather complicated, once having mastered it, he can operate the helicopter with ease. However, he did comment that the stability of the Dauphin can be further improved because it tends to wobble when a gust is encountered.

One of the outstanding features of the Dauphin is that the rotor blades are made of composite materials and the star shaped flexible blade housing made of fiberglass. The rotor has four blades made of glass cloth and carbon fiber; the diameter of the rotor is 11.93 m. The leading edge of each blade is covered with a stainless steel shield for protection against debris during take-off and landing. A composite material rotor has the advantage that any mechanical injuries such as cuts and dents will not cause fatigue damage; its useful life can exceed 5,000 hours. The star-shaped flexible blade housing does not require lubrication; its structure is simpler and has fewer parts than ordinary metallic housing. Therefore, it is easier to maintain, and provides safer and more reliable service. Furthermore, the structural design of the rotor blades and blade housing is such that vibrations during flight are reduced. This not only improves passenger comfort but also prolongs the useful lives of parts and instruments on the helicopter.

This demonstration and inspection of the Dauphin 2 left us with a deep impression. According to the comrade of CAIEC, adaptation of foreign technologies not only will help us learn the most advanced technologies in manufacturing helicopters, but also provide us with the capability to build high performance medium size helicopters for economic construction. At the same time, adapting foreign technology for domestic production will save considerable foreign exchange compared to purchasing the helicopters from abroad.

#### The Future of Domestic Helicopters

As our car left the Capital Airport and returned to Beijing, this reporter's thoughts drifted from the Dauphin to future domestic helicopters.

The helicopter is an essential vehicle for economic and defense construction. The number of helicopters produced has increased dramatically during the last decade; helicopter technology has also been improving continuously. In particular, the requirement of off-shore petroleum development has stimulated the production of helicopters for oceanic operation; advance in tactical missile technology has motivated the direct use of helicopters in battles, and the problem of hardening helicopters is receiving an increasing amount of

attention; also, increasing emphasis of anti-submarine warfare has placed heavier demands on ship-based helicopters. During the recent struggle for the Malvinas Islands between England and Argentina, both sides used missiles launched from helicopters to attack enemy ships. This is a good example of the effectiveness of helicopters in modern warfare.

Since the 50's, the helicopters produced in this country have been primarily the V-5, which is an adapted version of the M-4. This helicopter has played an important role in transportation, mineral exploration and forest protection, elimination of farm insects, military training, and rescue operations, etc. In 1966, after the strong earthquake which hit the Jin-Tai region of Hubei province, this reporter flew on one of the V-5 helicopters sent by the Air Force to villages near the center of the earthquake, and reported on the moving scenes of local militia using helicopters to ship critically injured victims. At that time, many roads and bridges were so badly damaged that motor vehicles could not get through. In some villages where all the houses had collapsed, the only way to move the injured to a nearby hospital was to land helicopters in a field next to the village. Each helicopter can carry eleven to twelve people (see the article "A Flight With Class Sentiment" in the May 1966 issue of this journal). Even though the pilots were constantly subject to vibrations and noises, they rarely took time off for rest. As soon as the injured were unloaded and the fuel tanks were refilled, they took off to another village. Without helicopters, many lives of the injured victims would have been lost.

Now in the 80's, the technologies of the V-5 have become obsolete. The newly adapted Dauphin has the same payload as the V-5, but its performance is superior to the V-5 in terms of range, speed, and reliability. Clearly, it is a good replacement for the V-5 as a medium-size multi-purpose helicopter.

However, to cover China's vast territory and to accomplish the difficult missions of socialist construction and national defense, only one type of domestic helicopters is clearly not adequate. We hope that in the near future, more and better Chinese-made helicopters will be seen in the sky to satisfy the many needs of the people.

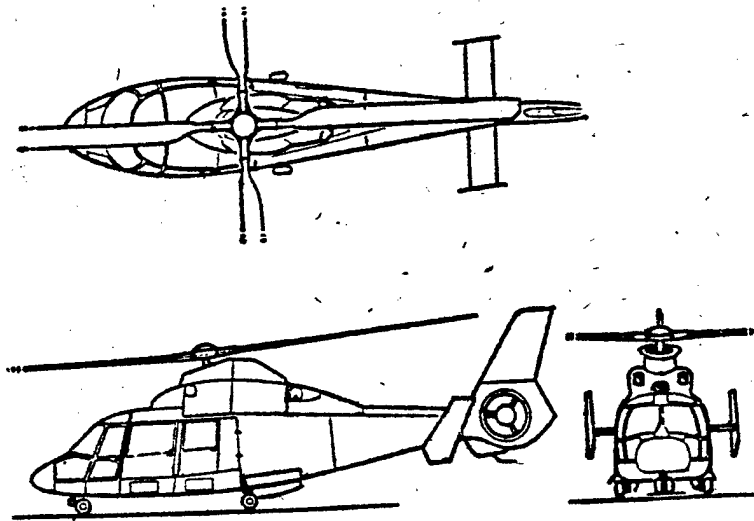

Fig. 1 The Three Views of Dauphin SA 365N

The specifications of this helicopter are as follows: rotor diameter 11.93 m, length 11.44 m, height 4.01 m; maximum take-off weight 3,850 kg, effective payload 1,810 kg, maximum external load 1,700 kg; maximum speed 306 km/hr, maximum cruising speed 293 km/hr, cruising speed 260 km/hr, maximum range 880 km, fuel capacity 1,140 liters.

3012

CSO: 4008/203

APPLIED SCIENCES

NATIONAL AEROTECHNOLOGY IMPORT-EXPORT CORPORATION EXPANDS BUSINESS BASE

Beijing HANGKONG ZHISHI [AEROSPACE KNOWLEDGE MAGAZINE] in Chinese No 7,  
Jul 82, p 7

[Article by Hang Yan [2635 1484]]

[Text] During a trade fair in the fall of 1979, the National Aerotechnology Import and Export Corporation (NAIEC) for the first time put on display a group of unique mechanical and consumer products such as commercial airplanes, motorcycles, and precision equipment and tools. The high quality and sophisticated technology demonstrated by these products attracted a great deal of attention from foreign businessmen.

With the increasing market demand, NAIEC has been steadily expanding its business base. Currently it handles aviation products such as airplanes, engines, flight instruments, electrical devices, accessories, and parts. It also handles non-aviation products such as precision machine tools, numerically-controlled lathes, precision test equipment, motorcycles, bicycles, medical equipment, baking and drying apparatus, optical machines, various engineering measuring tools, cast and forged parts, electronic and electric products, and parachutes, etc. Because of the insistence on quality, many of the products handled by NAIEC have established a good reputation on the international market. These products include: rulers, meters, granite platforms, gage blocks, drill bits, fibers, filing tools, knives, pliers, and magnetic platforms, etc. The export volume of these merchandise is quite large; some of the items are in such high demand that the supply can hardly keep up. The Chinese-made model airplane engines which broke three world records have also become big export items.

In order to further these products and to renovate the aeronautical industry, a number of export bases are being established. For example, a "NAIEC Industrial and Trade Center" located in the Shenchuan financial district is now under construction. Several factories in the Center, e.g., the Nanhang Electronic Factory, the Aluminum Processing Plant, and the Shenchuan Aeronautical Precision Model Factory which was built with foreign investment, have started production.

NAIEC is also involved in architectural design projects, particularly in blueprint preparation and modification. This type of work is attractive to Western countries because of the availability of large labor force and high technical standards. Within a year, NAIEC has signed contracts with a number of companies abroad.

To improve the quality of products, aeronautical and related industries in this country have made significant achievement by learning from the experiences of advanced nations abroad, conducting technical training classes, and by implementing specific technological innovations. Some industries have received certification from companies abroad for meeting the quality-control specifications in the contract; others have developed products rated by foreign companies as being of "superior quality."

With the increase in foreign trade, NAIEC has established subsidiaries in Guanzhou, Fuzhou, Shanghai, and branch offices in Shenchuan and Xiameng. It has also set up liaison offices in London, Bordeaux, Marseille, and has established economic and technological cooperative programs with factories and businesses in more than 40 countries. In 1981, NAIEC improved its trade efforts by inviting foreign businessmen to China and sending sales representatives overseas to advertise its products. A total of 15 trade delegations were sent to the United States, England, West German, Japan, Italy, Sweden, Portugal, Argentina, Thailand, and Hong Kong to engage in advertising and trade activities. In addition to participating in the twice-yearly trade fairs, NAIEC also sponsors exhibits of aeronautical cast and forged parts to allow foreign businessmen to further understand the production capability and technical standards of China's aeronautical industry. As a result of the frequent business contacts, an increasing number of people have initiated business negotiations with NAIEC.

At present, NAIEC is in the process of improving its foreign trade system. Since 1980, the foreign trade management policy has been undergoing changes in an attempt to motivate various industrial personnel to promote export trade and foreign exchange. The basic change involves the assurance that each industry would benefit from its contribution to increased export and foreign exchange. Under the general guideline of complying with national plan and providing a unified front, each industry can increase its export quota and enjoy the return from its share of foreign exchange. The important products are exported collectively by NAIEC, but industry representatives have the right to participate in negotiations with foreign merchants. For general products, each industry is responsible for the sales as well as profits or loss, and NAIEC serves as a management agency. For certain products that have good market potential but are easily separable such as cast and forged parts, tools and hardware, special associations have been set up for the purpose of conducting market research, coordinating, and providing guidance to basic production units. In addition, effective policies and regulations have been established to improve quality control and to provide technical service, so that foreign trade and export activities may be further developed.

3012

CSO: 4008/203

APPLIED SCIENCES

PLANS FOR MECHANICS SOCIETY'S ACADEMIC ACTIVITIES ANNOUNCED

Beijing LIXUE YU SHIJIAN [MECHANICS AND PRACTICE] in Chinese No 2, 1982 pp 72-73

[Article by correspondent of this magazine: "Plans for Academic Activities of the China Mechanics Society in 1982"]

[Text] 1. Fatigue Discussion Meeting: In October 1982, the China Mechanics Society will cosponsor this meeting with the China Aviation Society. The agenda of the meeting will include fatigue damage, expansion of fatigue cracks, fatigue statistics and reliability analysis, fatigue load spectroscopic tests, counting methods, methods of compiling spectra, fatigue property tests, and study of the mechanism of fatigue destruction.

2. Discussion Meeting on Calculations for Structural Dynamics: This meeting will be held at Chungqing in the 4th quarter of 1982. The content will be to discuss the activities for that profession, major problems and research methods.

3. Exchange Meeting on Weighted Residuals Method: The meeting will be held in May 1982 at Xiamen. The content will include theoretical research and application of the weighted residuals method used in mechanics of solids, and the comprehensive utilization of that method with other methods.

4. Third Academic Conference on Structural Mechanics of Reactors: The meeting will be held in October and November 1982, at Beijing. The content will include problems in the mechanics of nuclear reactor structures, their computation, experiments and tests.

5. Second National Composite Materials Academic Meeting: This meeting will be held in August 1982, in Harbin. It will be jointly sponsored by the Mechanics Society, the China Space Flight Society and the China Aviation Society. The content will emphasize advanced composite materials, including the mechanical properties of composite materials, their structural mechanics, nonlinearity, visco-elastic properties, plasticity, visco-plastic properties for analysis in mechanics of materials, wave propagation and the finite method, numerical method in structural analysis, breaking and fatigue of materials, analysis and design for connecting composite materials, structural design, computation and optimization, testing and research.

6. Third National Experimental Stress Analysis Academic Conference: This will be held in the 3d quarter of 1982 in Sichuan. The content includes new

progress in the measurement of scattered spots of interference in holography and new developments in the cloud streak method, basic methods of photoelasticity and its application in new realms of mechanics (biomechanics, mechanics of breaking), electrical measurement technology under special conditions, data collection and processing, application of experimental stress analysis in engineering, especially in the development of energy resources and energy conservation. The conference will have a small exhibition to display new scientific research achievements, instruments and equipment, materials and components.

7. Academic Conference on Physical-Chemical Flow, Multiphase Flow, Non-Newtonian Fluid Mechanics: This conference will be held in April 1982, in Beijing. The content will explore and exchange information on theoretical research, experimental research and applications research in other related realms.

8. Conference on Computational Fluid Mechanics: This meeting will be held during the 2d quarter of 1982 in Chengdu. It will be jointly sponsored by this society and the China Aerodynamics Research Society. The meeting will discuss the computational methods in fluid mechanics, the calculation of flow in circular flow problems, hydromechanics, wave motion of gases, river and ocean and atmospheric mechanics, magnetic fluid mechanics, biological fluid mechanics, space aerodynamic mechanics and calculations in fluid mechanics for other engineering projects.

9. Conference on Fluid Mechanics of Percolation: This meeting will be held during the 3d to 4th quarter of 1982, at Lanzhou. It will discuss theoretical research in percolation, experiments and test studies and testing techniques and their application in the national economy.

10. Academic Conference on Flow Stability, Turbulence and Boundary Layers: This meeting will be held in October 1982. The content will include the study of flow stability and turn-about phenomena in various fluids (including gas, water and other media), even isotropic turbulence, shear turbulence (such as jetstreams, tail streams, free mixture layers and others), the basic theory of these branch sciences such as the boundary layer of fluids, semi-empirical analysis, numerical calculations and experimental measurements.

11. Academic Exchange Meeting of First Flow Spectroscopic Display Technology: This meeting will be held during the 2d quarter of 1982, in Xiamen. The content will include the method of display, the use of new equipment in research such as the method of external addition of materials and optical methods, image recognition and calculations for quantitative analysis, analysis of three-dimensional flow fields and holographic interference, and the application of display techniques in various fields.

12. Learning Class in Gas-Solid Phase Fluidics: This will be held in July 1982, in Harbin. The book "Fluid Dynamics of Multiple Phase Systems" by Su Shaoli [5685 4801 4409] will be translated by chapters as class preparation. Participants will be allowed to speak and will hold collective discussion. This year, chapter 5 will be discussed.

13. Discussion Meeting on Flow Stability: This meeting will be held in the 4th quarter of 1982 to explore the theory of flow stability and its control.
14. Academic Meeting on Soil and Rock Blasting: This will be held during the 2d quarter of 1982. The content includes detonation theory, various types of detonation techniques (such as shallow holes, caverns, underwater, deep holes, smooth surface, precracking, pressure resistance, safe blasting) and means of observation, development of cheap explosives, and safety techniques in blasting.
15. Academic Conference on Explosive Processing: This will be held during the 2d quarter in 1982. It will discuss explosion of industrial dynamites, the effect of shock waves on the properties of metals and the structure of metals, pulverized metal forming, explosive welding, explosive cutting and explosive hardening, explosive forming and other equipment.
16. Academic Conference on Nonlinear Mechanics: This will be held in the 3d or 4th quarter of 1982. It will explore the nonlinear theory and its computational research.
17. Discussion Meeting on Cardiovascular Dynamics: This will be held in the 3d quarter of 1982 at Xiamen. It will introduce current research in cardiovascular dynamics at home and abroad and achievements will be exchanged.
18. Discussion Meeting on Mechanical Properties of Rocks Related to Earthquakes and the Interior of the Earth and Mechanical Mechanisms of Earthquake Indications: This will be held during the 3d quarter of 1982 to introduce the work at home and abroad and to exchange achievements.
19. Discussion Meeting on Civil Engineering: This will be held in the 4th quarter of 1982. It will combine the discussion with an actual project to discuss rock engineering mechanics and stress distribution in the region.
20. Reading Class in Soil Mechanics of Critical States: This will be held from September to October 1982. The content will mainly include the  $\sigma - \epsilon$  of the basic knowledge of the theory of elastoplasticity and strength patterns.

9296

CSO: 4008/177

APPLIED SCIENCES

CONFERENCE ON MACHINERY HEAT TREATMENTS HELD

Beijing JINSHU RECHULI [HEAT TREATMENT OF METALS] in Chinese No 4, 1982 inside back cover

[Conference notes: "Activities of the Society and the Profession"]

[Text] The National Light Industrial Machinery Nitrogenation Field Conference was held from 12 to 19 October 1981, in Shanghai. Attending the conference were 110 delegates from 23 provinces and cities. During the conference, there were special reports, exchange of experience, special subject lectures, on-site demonstrations, and the delegates were organized to conduct metallic phase sample making and test analysis. Good results were realized. The conference discussed the key points in heat treatment work for light industrial machinery in the future: Further to grasp well the reorganization of the enterprises, improve the level of business management, exert efforts in stabilizing and improving the quality of heat treatment; coordinate efforts closely with the products to elevate their grades and to create superior products and to overcome difficulties; draw up plans to improve heat treatment techniques, exert key efforts to improve product quality, energy conservation, labor conditions, and economic gain; strengthen the means of testing, conduct technical training according to plan, gradually establish a backbone team in heat treatment techniques for light industrial machinery, and actively utilize new technologies according to the characteristics of each plant.

9296

CSO: 4008/177

DEVELOPMENT OF DIRECTIONAL SOLIDIFICATION TECHNOLOGY IN CHINA

Beijing GUOJI HANGKONG [INTERNATIONAL AVIATION] in Chinese No 5, May 82 pp 39-43

[Article by Xue Yanlu [5641 1693 4389]\*]

[Text] During the mid-1960's, Pratt and Whitney of the United States successfully developed directionally solidified high temperature alloys and turbine blades. This has attracted the attention of all nations of the world. The Beijing Aviation Materials Research Institute was the first to develop such research in 1968. Later, some research institutes, schools and factories followed and all realized definite achievements. For more than a decade, China has built a technical team with a definite technical standard in this aspect. They have remodeled, designed, manufactured and introduced some directional solidification equipment, developed the power drop method, the high rate solidification method and the liquid metals cooling method and other such processes of directional techniques. They have successfully developed some directionally solidified alloys and produced many types of directional turbine blades for aviation engines. Some have been factory tested and some have been tested in flight and they have passed evaluation by the state. These research achievements have actively pushed forward the development of our nation's aviation industry and at the same time provided favorable conditions for producing engines with a high thrust ratio and long life. This article is a brief introduction to the present development of directionally solidified turbine blades in our nation.

I. Directional Solidification Technology and Facilities

1. Directional Solidification Technology. The development of directional solidification technology in our nation went through a gradual development from the simple to the complex and from low grades to high grades (see Figure 1). At first, the relatively simple power drop method was used. Equipment was remodeled from ordinary vacuum induction furnaces. The characteristics of this technology are as follows: The casting mold heater has two sections. After pouring, the power is gradually reduced and the casting model remains stationary throughout the solidification process. The directional solidification of the cast is completed mainly by heat conduction through the water cooled crystallizer at the bottom (See Figure 2). Because this method has a small temperature gradient, the speed of solidification allowed is low, therefore productivity is not high, the direction of the pin crystals is scattered and

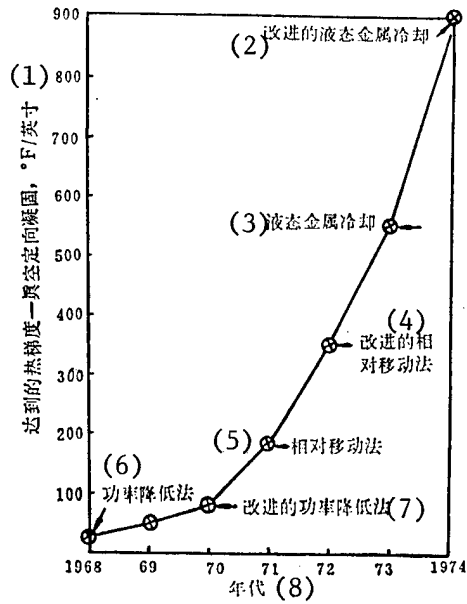

- Key:
- (1) Heat gradient-vacuum directional solidification reached, F/inch
  - (2) Improved liquid metal cooling
  - (3) Cooling of liquid metal
  - (4) Improved relative shift method
  - (5) Relative shift method
  - (6) Power drop method
  - (7) Improved power drop method
  - (8) Year

Figure 1. Course of Development of Directional Technology in Our Nation

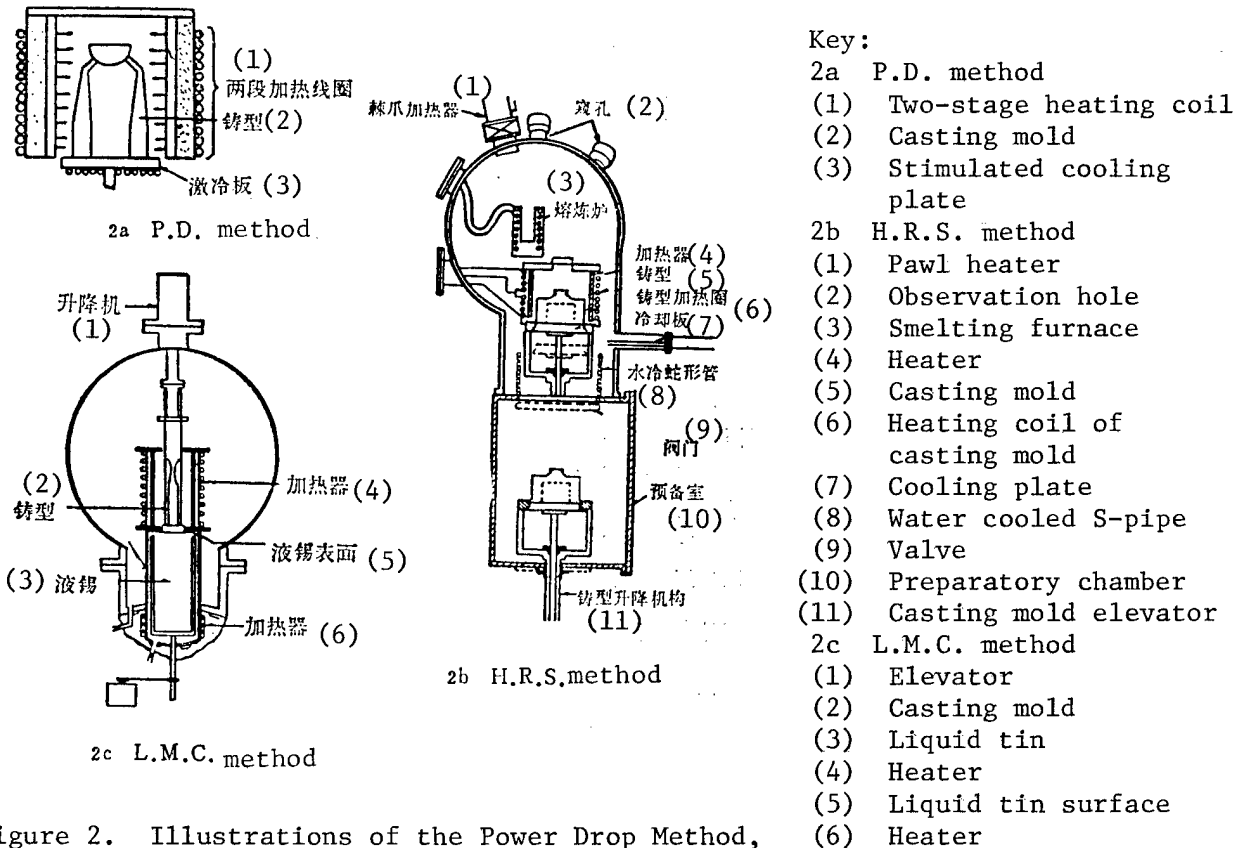

Figure 2. Illustrations of the Power Drop Method, the High Rate Solidification Method and the Liquid Metal Cooling Method

the pins are not tall and straight. The structure and properties of the top and bottom blades with a length of less than 150 millimeters and it cannot satisfy the demand for producing long blades of superior quality. To satisfy the needs in the development of our nation's aviation industry, the high rate solidification method was developed in the 1970's. The characteristic of this method is that after the cast is filled with liquid metal, the liquid metal is removed slowly from the casting heater. The dispersion of heat when the alloy solidifies not only relies on heat conduction of the crystallizer at the bottom, it also depends on heat radiation from the cast to the surroundings (see Figure 2). Therefore, its temperature gradient is greater, the rate of solidification allowed is faster, and productivity is higher. Also, this method is favorable to the strict control of technological parameters. The directional deviation of the pin crystals of the cast is small and the structure and properties of the top and bottom parts are more consistent. Now, we can produce blades of 220 millimeters long and plates of 250 millimeters long (see Figure 3).



Figure 3. DZ-22 Alloy Plate Poured by the High Rate Solidification Method

As experimental research work continues to deepen and as technology continues to be perfected, the control of various technological parameters has become more stringent. Compared to data published in foreign nations, it can be seen that the current technological parameters in our nation are basically the same as those of foreign nations (see Table 1).

Table 1. Comparison of Current Technical Parameters in Our Nation and Foreign Data (results of thermal analysis)

Parameters		Power drop method	Low rate solidification method	Improved high rate solidification
Temperature gradient G, C/centimeter	A	10 - 15	20 - 40	--
	B	8 - 16	19 - 27	16 - 32
Rate of solidification R, cm/hour	A	5 - 10	20 - 30	--
	B	40 - 120	100 - 200	100 - 55
Width of mushy area $\Delta X$ , cm	A	12	3	--
	B	3 - 6	2 - 2.7	$\leq 2$
G/R value, $^{\circ}\text{C}\cdot\text{hour}/\text{cm}^2$	A	1.5 - 2	1 - 1.3	--
	B	0.05-0.3	0.3 - 0.7	0.2 - 0.6

Remarks: A Data published abroad

B Data of the Beijing Aviation Materials Research Institute. The data are the results of thermal analysis conducted for the parts poured in the remodeled directional solidification furnace.

In addition, China has also developed the liquid metal cooling method. The characteristic of this method is that the cast filled with poured metal is directly submerged in liquid metal of a low melting point for cooling (see Figure 2). Because the temperature gradient is even larger and the speed of solidification allowed is even higher, therefore the quality of the cast is good and productivity is high. Especially worth mentioning is that our nation has already developed a type of metal cooling agent with a melting point of only 5 to 15 $^{\circ}\text{C}$  to replace commonly used tin which has a melting point of 238 $^{\circ}\text{C}$ . The agent can be used under normal temperatures and complex cooling equipment is not needed. This not only elevates the quality of the cast, it will also visibly push forward the study of directional alloys and cocrystalline alloys. But this technology requires continuous production facilities and its economic characteristics have to be solved further.

2. Directional solidification equipment. To satisfy the needs in the research of directional solidification technology and the production of directional blades, our nation began as early as the 1960's to design and manufacture a directional solidification furnace that can automatically control its temperature and that can serve continuous production (see Figure 4).

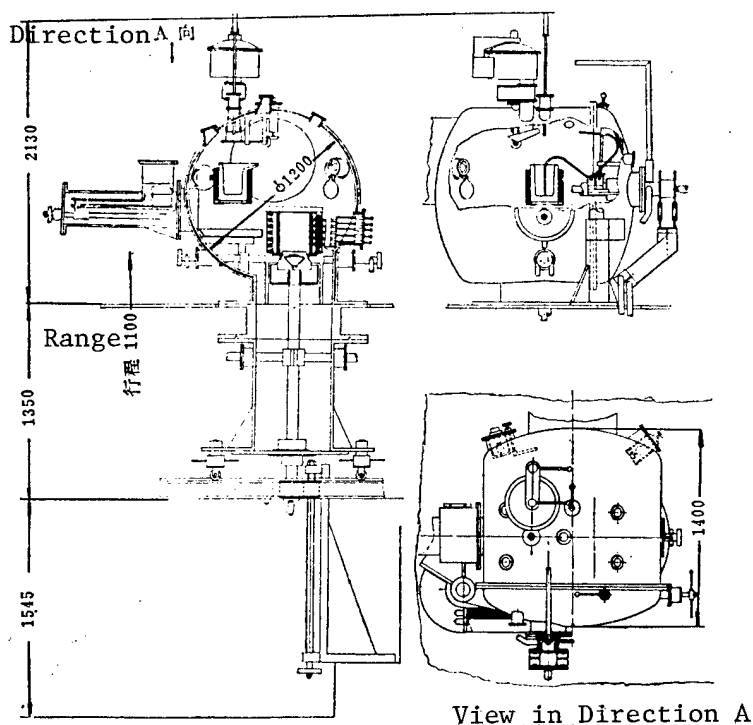

Figure 4. Directional Solidification Furnace Designed by Ourselves (unit millimeter)

Its major technical parameters are as follows:

Body of furnace: horizontal (melting chamber, pouring chamber, horizontal feeding chamber)

Melting and shell heating temperature: 1700°C

Maximum degree of vacuum:  $5 \times 10^{-4}$  millimeters mercury column.

Air leakage rate  $\leq 0.5$  micrometer/minute

Rate of rise and fall of crystallizer: 2.5 to 20 millimeters/minute.

Fast speed: 50 to 400 millimeters/minute.

Speed of spin of crystallizer: 1 to 5 revolutions/minute.

In recent years, China has imported the 5241-2D/S-A model directional crystallization furnace from the Vacuum Engineering Industries Ltd. of the United States and the IPS<sup>2</sup> /III-DS model directional crystallization furnace from the Leyboed-Heraeus Company of West Germany. Figure 5 shows the ISP<sup>2</sup> /III-DS model directional crystallization furnace that has already begun production.

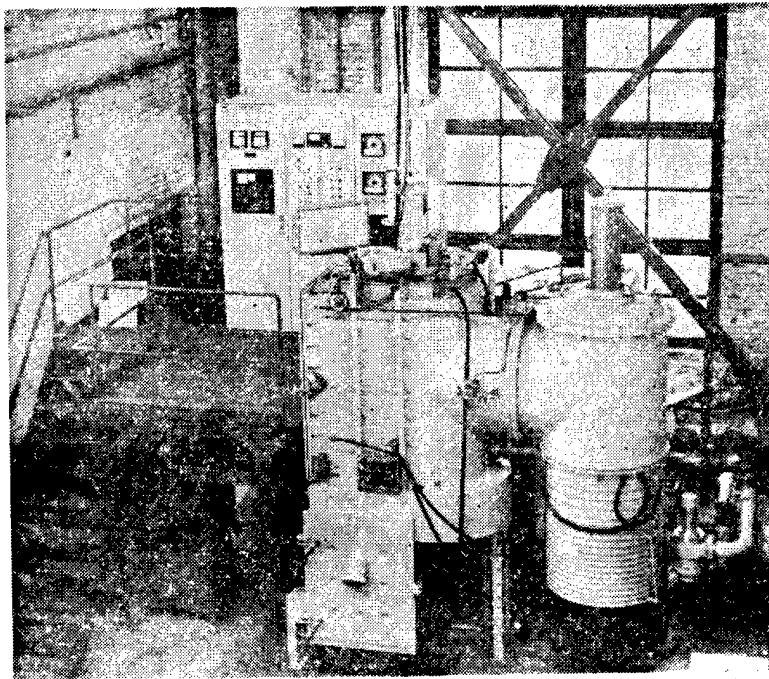

Figure 5. The ISP<sup>2</sup>/III-DS Model Directional Solidification Furnace That Has Already Begun Production

## II. The Mold of Directional Porcelain Shell and the Core of the Porcelain Mold

1. The Shell Mold. The shell mold used for directional solidification is different from that used for ordinary fine casting. First, the single shell used for directional solidification must retain its strength for long periods (>40 minutes) under a temperature reaching 1,550°C when overheated and melted metal is poured into it. Second, in directional solidification, the temperature difference between the top and the bottom parts of the casting mold is very large (generally about 100°C to 1,650°C). Therefore, the load softening point of the shell mold must be high and the thermal stress sensitivity must be low. The shell must not split open, it must not deform, and it must not produce mold cavity reactions. To satisfy the above requirements, we have developed many types of shell mold materials and shell manufacturing techniques. At the beginning we used ordinary ethyl ester silicate-corundum series shell molds but we did not obtain satisfactory results. At the beginning of the 1970's, we began studying shell molds of the silica sol-aluminum vanadine [alumina] series. These types of shell molds have good high temperature strength and resist deformation. The technique is simple. Many types of directionally crystallized blades for aviation engines were poured using this type of shell molds (See Figure 6). Because aluminum-vanadine has a better heat conductivity, it can adjust the temperature distribution in the interior

of the mold cavity in time when the metal solidifies and it can make the pin crystals grow thin, long and straight. But, aluminum-vanadine contains impurities and pollutes the surface of the castings. At the same time, the quality of the raw material of aluminum-vanadine is difficult to control. Sometimes, the castings are abandoned because the quality of the shell mold is poor. These all need to be further solved. In recent years, we have also successfully developed a new shell mold material for directional solidification and new shell mold material for directional solidification and new shell manufacturing techniques. This new shell mold has a high strength under high temperatures, deformation is small, stability is good, and these properties have surpassed those of all the shell molds used in the nation at present, and they have created favorable conditions for production of directional nonresidual blades (Figure 7 shows the new shell mold ready for pouring for directional solidification). Table 2 lists the chemical composition of aluminum-vanadine and its physical properties.

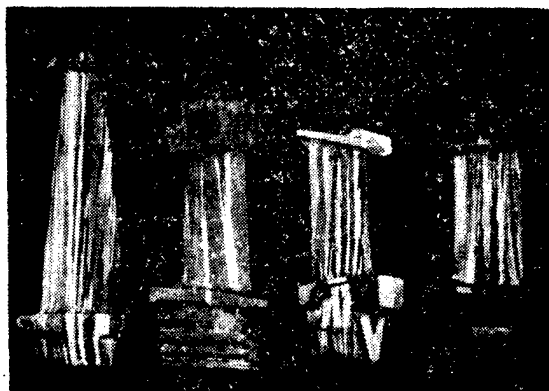

Figure 6. Several Types of Turbine Blades for Aviation Engines Produced in China

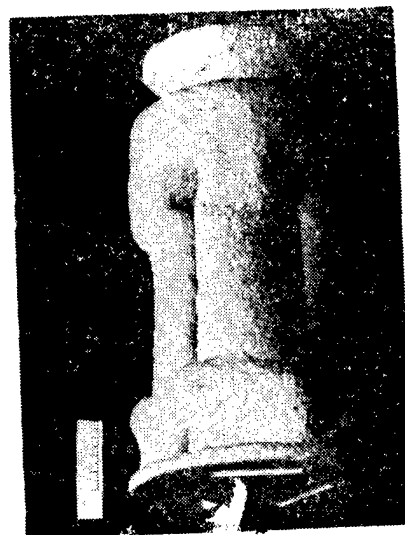

Figure 7. Shell Mold for the Ethyl Ester Silicate-Corundum Series Blades Awaits Pouring

Table 2.

Chemical Composition

Al<sub>2</sub>O<sub>3</sub> ~ 68 percent  
 SiO<sub>2</sub> ~ 25 percent  
 Fe<sub>2</sub>O<sub>3</sub> ~ 1.3 percent  
 TiO<sub>2</sub> ~ 2.8 percent  
 CaO MgO ~ 0.6 percent  
 K<sub>2</sub>O+Na<sub>2</sub>O ~ 0.1 percent

Physical Properties

Mullite 80 percent  
 Degree of fire resistance >1,770°C  
 Porosity ~35 percent  
 Ash content †0.5 percent

## 2. Mold Core

The porcelain mold core used for pouring directional hollow blades is the same as that of the shell mold. It has to bear many working conditions that are much harsher than those in ordinary fine casting. The mold core material must be strong in high temperatures, the thermal stability must be good, and removal of the core must be easy. For several years, our nation has conducted research in oxidized magnesium based and quartz glass-zirconium quartz powder based porcelain mold core materials and we have finally developed successfully a mold core material suitable for use in manufacturing directional hollow blades. At present, we already can manufacture directional hollow blades with a wall thickness of less than 1 millimeter, an aperture of 0.2 to 0.5 millimeter, relatively complex interior channels and interior cavities that have a smoothness reaching  $\nabla 4$  to  $\nabla 6$ . Figure 8 shows the external shape of hollow turbine blades for engines and the porcelain mold core used.

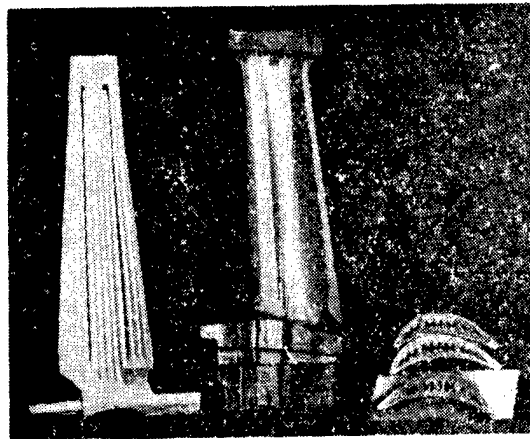

Figure 8. The Turbine Blades for a Certain Engine and the Porcelain Mold Core Used in China

### III. Development of Directionally Solidified Alloys

The continued perfection of directional solidification technology has created conditions for the development of directionally solidified alloys. For more than 10 years, our nation has continued to develop successfully a number of directionally solidified high temperature alloys and these have preliminarily formed our nation's series of directional high temperature alloys, such as: DZ-3, DZ-5, DZ-9, DZ-17G, DZ-22, etc. (Please refer to the no 4 issue of this magazine for 1981, for their chemical compositions). These alloys all possess good comprehensive mechanical properties in high temperatures and medium temperatures and superior heat fatigue properties and satisfactory thin wall properties. The DZ-3 and DZ-22 alloys are the most outstanding.

Table 3. Comparison of Instantaneous Properties of the DZ-3 and DZ-22 Alloys and the  $\mathbb{H}$  C6KHK, PWA-1422 Alloys

Alloy	Temp. °C	$\sigma_b$ , kg/mm <sup>2</sup>	$\sigma_{0.2}$ , kg/mm <sup>2</sup>	$\delta$ percent	$\psi$ percent	Remarks
DZ-3	room temp.	98/100	--	5.0/7.0	4.0/7.0	
	760	119/120	--	9.6/11.4	15.8/20.4	
	900	91/93	--	8.0/9.2	11.2/11.2	
	980	69/70	--	21.0/29.4	31.2/31.8	
	1000	65	--	19	34	
$\mathbb{H}$ C6KHK	room temp.	90		3.6		
	900	98/109	81/85	--	--	
DZ-22	room temp.	116	--	8.0	9.0	
	760	121	--	8.0	15.0	
	980	65	--	13.0	28.0	
	1000	60	--	23.0	28.0	
PWA1422	room temp.	113	96	6.1	8.3	
	760	121	98	9.0	14.0	
	980	63	49	21.8	28.0	

Table 4. Comparison of Permanent Properties of the DZ-3 and DZ-22 Alloys and the  $\mathbb{H}$  C6KHK, PWA 1422 Alloys

Alloy	Temp. °C	Stress, kg/mm <sup>2</sup>	Useful life, hours	$\delta$ percent	Remarks
DZ-8	760	78	100		
	900	35	100		
	980	21	100		
	1040	14	100		
	1093	8.4	100		
$\mathbb{H}$ C6KHK	900	32/34	100		
	975	23	70	--	
		26	64	18	
DZ-22	760	73.8, 78	210	14.8	
	870	45.7	122	25	
	980	22.5	84	20.4	
	1040	14	110	24.8	
	1093	8.44	75	30	
PWA1422	760	70.3	700	3.2	
	870	42	180	6.3	
	980	21.1	70	19.0	
	1040	12.66	130	20.0	

Our nation's research in directional alloys was carried out on the basis of currently available high temperature cast alloys. Appropriate directional techniques were developed for ordinary cast alloys to obtain better comprehensive mechanical properties in high temperatures and medium temperatures and superior heat fatigue properties and satisfactory thin wall properties. The DZ-3 and DZ-22 alloys are the most outstanding.

Our nation's research in directional alloys was carried out on the basis of currently available high temperature cast alloys. Appropriate directional techniques were developed for ordinary cast alloys to obtain better comprehensive mechanical properties. The emphasis in research work was mainly on understanding the effects of directional solidification technology upon the various properties of alloys, especially anticreep properties, thermal fatigue properties, thin wall properties, long period results and structural characteristics of directional alloys, etc. At the same time, we also studied parametric changes in adjustment and in the directional solidification technology for alloy elements (such as C, Hf) and the effect of the selection of the standards of heat treatment upon the structure and properties of alloys. After a lot of experimental research, we selected the suitable chemical compositions and technological parameters and obtained data on ideal comprehensive properties. We have already developed successfully several kinds of alloys which have properties that are superior to those of ordinary cast alloys of the same composition and we have reached the levels of similar types of foreign directional alloys as regards properties. Table 3 and 4 list the instantaneous properties and permanent properties of the DZ-3 and DZ-22 alloys and a comparison with those of the  $\text{HC6KHK}$  alloy of the Soviet Union and the PWA-1422 alloy of the United States. It can be seen from the data in the table that our nation's directional solidification technology has reached or is approaching the advanced levels of foreign nations.

In recent years, our nation has also developed research in monocrystalline alloys and directional cocrystalline alloys and has realized encouraging progress. This has established a good foundation for the further development of cast turbine blades for aviation engines.

#### Conclusion

The use of directional solidification technology to manufacture turbine blades for aviation engines can produce good results. This has been generally recognized domestically and abroad. For more than 10 years, our scientific and technical workers have done a lot of experimental research, have grasped and developed this advanced technology, have realized visible achievements and have contributed towards the development of our nation's aviation industry. At present, our nation not only has directional solidification equipment, technology and alloys of the world's advanced level, it also has a fairly large capability to produce directional blades. It can be believed that as our nation's aviation industry continues to develop, directional solidification technology will be more broadly applied in our nation.

9296

CSO: 4008/182

Engineering Thermophysics

AUTHOR: CHEN Yunxian [7115 6663 6897]  
CEN Kefa [1478 0668 3127]  
ZHANG Hesheng [1728 7729 5116]  
ZHANG Xuehong [1728 1331 1347]  
KANG Qifu [1660 7871 4395]

ORG: Zhejiang University

TITLE: "Experimental Studies of Fluidized Twin-Bed Boiler for Low Grade Solid Fuels"

SOURCE: Beijing GONGCHENG REWULI XUEBAO [JOURNAL OF ENGINEERING THERMOPHYSICS] in Chinese No 4, Nov 81 p 372

ABSTRACT: The construction principle of the industrial boilers with two fluidized beds operating in parallel is briefly introduced. According to the results of heat balance tests, it is evident that the thermal efficiency of the boiler when burning low grade solid fuels, may be increased from 53.9 to 70.7 percent as compared with the single fluidized bed boilers. Dynamic properties of combustion process in fluidized bed boilers when burning low grade solid fuels with broad size distribution and firing fly ash with narrow size distribution were experimentally determined, and the results of which were preliminarily investigated. Accordingly, problems in fluidized bed boiler design and operation have been examined, and reasons accounting for the increase of thermal efficiency are also given.

CSO: 4009/377

AUTHOR: None

ORG: The Editorial Department of the Journal

TITLE: "Brief News of the Conference of Engineering Thermodynamics and Energy Conservation and the Conference of Aero-thermodynamics of Heat Engines Held in Xiamen, Fujian Province "

SOURCE: Beijing GONGCHENG REWULI XUEBAO [JOURNAL OF ENGINEERING THERMOPHYSICS] in Chinese No 4, Nov 81 pp 408-409

ABSTRACT: On.18-24 Aug 81, the conferences of the 2 specialties of engineering thermodynamics and energy conservation and of aero-thermodynamics of heat engines were held simultaneously in Gulangyu of Xiamen. They were called jointly by the Chinese Engineering Thermophysics Society and the Chinese Aviation Society. There were 154 official delegates and substitutes; of these a large portion of the 304 authors of the submitted papers were middle-aged scientists. A portion of these delegates were old scientists and newly graduated researchers. Dr. LIU Ruisen [0491 3843 2773] a central figure of the Research Institute of Engineering, Dynamics, and Information Science of France was invited to deliver the report on "A New Method of Resolving Ternary Flow." Professor WU Zhonghua [07020112 5478], the Editor-in-Chief of this journal called an expanded meeting of editors of both societies during the conference time to make preliminary selections from the papers submitted to be gradually published in the journal. It was suggested at the conference that the international unit measurement system will be adopted in the journal, starting with the next year's issue.

6168

CSO: 4009/377

END