

Special Report 98-9

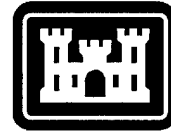

**US Army Corps
of Engineers®**

Cold Regions Research &
Engineering Laboratory

Site Characterization for Explosives Contamination at a Military Firing Range Impact Area

Thomas F. Jenkins, Marianne E. Walsh, Philip G. Thorne,
Paul H. Miyares, Thomas A. Ranney, Clarence L. Grant,
and John R. Esparza

August 1998

DTIC QUALITY INSPECTED 1

19980918 045

Prepared for
OFFICE OF THE CHIEF OF ENGINEERS

Approved for public release; distribution is unlimited.

Abstract: A study was conducted at the inland firing ranges at Fort Ord to determine the current levels of explosives residues and to recommend appropriate future site characterization techniques. A set of 280 soil samples was collected from depths ranging from 0–15 cm to 105–120 cm from anti-tank ranges 44 and 48. Sampling locations were selected on the basis of the locations of current and former targets, and included an area away from specific targets and a background area, not affected by local detonations. HMX was the explosives residue present at the highest concentra-

tion. Much lower concentrations of RDX, TNT, and two isomers of aminodinitrotoluene were also detected. Explosives residues were largely confined to surface soils near tank targets. A major problem for site characterization was found to be the large spatial heterogeneity present. Composite samples very effectively provided representative samples for 5- × 5-m size grids. A colorimetric on-site method gave reliable results for HMX, relative to SW846 Method 8330. No currently available on-site method for RDX was found to be adequate in the presence of much higher concentrations of HMX.

How to get copies of CRREL technical publications:

Department of Defense personnel and contractors may order reports through the Defense Technical Information Center:

DTIC-BR SUITE 0944
8725 JOHN J KINGMAN RD
FT BELVOIR VA 22060-6218
Telephone 1 800 225 3842
E-mail help@dtic.mil
msorders@dtic.mil
WWW http://www.dtic.mil

All others may order reports through the National Technical Information Service:

NTIS
5285 PORT ROYAL RD
SPRINGFIELD VA 22161
Telephone 1 703 487 4650
1 703 487 4639 (TDD for the hearing-impaired)
E-mail orders@ntis.fedworld.gov
WWW http://www.fedworld.gov/ntis/ntishome.html

A complete list of all CRREL technical publications is available from:

USACRREL (CECRL-LP)
72 LYME RD
HANOVER NH 03755-1290
Telephone 1 603 646 4338
E-mail techpubs@crrel.usace.army.mil

For information on all aspects of the Cold Regions Research and Engineering Laboratory, visit our World Wide Web site:
<http://www.crrel.usace.army.mil>

PREFACE

This report was prepared by Dr. Thomas F. Jenkins, Research Chemist, Marianne E. Walsh, Chemical Engineer, Philip G. Thorne, Research Physical Scientist, Geological Sciences Division, Dr. Paul H. Miyares, Research Chemist, Geochemical Sciences Division, Research and Engineering Directorate, U.S. Army Cold Regions Research and Engineering Laboratory, Thomas A. Ranney, Science and Technology Corporation, Hanover, New Hampshire, Dr. Clarence L. Grant, Professor Emeritus, Chemistry Department, University of New Hampshire, Durham, and John R. Esparza, Chemist, U.S. Army Engineer District, Sacramento. Funding for this work was provided by the U.S. Army Engineer District, Sacramento, John Esparza, Project Monitor and the U.S. Army Environmental Center, Martin H. Stutz, Project Monitor.

The authors gratefully acknowledge the assistance provided by A.R. Smith, Sacramento District, and personnel from CMS Corporation, Monterey, California, in providing clearance for the possible presence of unexploded ordnance (UXO) and for collecting soil samples from explosives contaminated areas. The authors also acknowledge Dr. Ramzi J. Mahmood, California State University at Sacramento, David Eisen, Sacramento District, Alan Hewitt, CRREL, and Martin H. Stutz, U.S. Army Environmental Center, Aberdeen Proving Ground, Maryland, for their technical review of this report. In addition, the authors acknowledge Jane G. Mason, CRREL, for assistance in preparation of the figures presented in this report, and Mark Hardenberg, CRREL, for editorial assistance in the final preparation of this report.

This publication reflects the personal views of the authors and does not suggest or reflect the policy, practices, programs, or doctrine of the U.S. Army or Government of the United States. The contents of this report are not to be used for advertising or promotional purposes. Citation of brand names does not constitute an official endorsement or approval of the use of such commercial products.

CONTENTS

	Page
Preface	ii
Introduction	1
Background	1
Objective	2
Experimental methods	5
Sampling design	5
Soil sample collection	7
Homogenization and subsampling for discrete soil samples	7
Preparation of discrete samples used to assess the effect of sample size on heterogeneity	8
Preparation of composite samples	8
Collection and analysis of dust samples	8
Soil sample extraction and HPLC analysis	8
Extraction time assessment and evaluation of on-site methods for RDX and HMX	9
Results and discussion	9
Overview of explosives detected in the various sampling areas	9
Depth of contamination	9
Areal distribution of contaminants	11
Spatial heterogeneity	15
Evaluation of various on-site methods for use with soils from the inland ranges	17
Composite preparation	19
Summary and conclusions	20
Literature cited	24
Appendix A: Guide for preliminary testing of munitions-contaminated sites—preparation for sampling plan	27
Appendix B: RP-HPLC analysis data from Fort Ord samples	33
Abstract	41

ILLUSTRATIONS

Figure	
1. Structures of explosives detected at the Fort Ord inland firing ranges	2
2. Ford Ord	3
3. HMX concentrations (mg/kg) in soil at Canadian Force Base-Valcartier firing range, relative to placement of tank targets	4

	Page
4. 66-mm M72 LAW rocket	5
5. Sampling grids for area 1-44	6
6. Locations of sampling points within a grid	6
7. Concentration (mg/kg) of explosives residues as a function of depth for grid A, sampling location 1-44	12
8. Areal distribution of explosives residues (mg/kg) in surface soils for sampling location 1-44	14
9. Correlation of HMX concentration estimates from the colorimetric on-site method with those from RP-HPLC analysis of the same acetone extracts	19
10. Log-normal distribution of HMX for discrete soil samples from grid A, sampling location 1-44	22
11. Concentration of HMX in surface soils at Fort Ord sampling location 1-44 and CFB-Valcartier as a function of distance from targets	22
12. Proposed concentric ring sampling plan for target areas	23

TABLES

Table

1. Water quality criteria for selected explosives	4
2. Concentrations of HMX by SW-846 Method 8330 at firing range 44	10
3. Concentrations of RDX, TNT, 4-AmDNT, and 2-AmDNT by SW-846 Method 8330 in surface soils at firing range 44	11
4. Concentrations of HMX and RDX by SW-846 Method 8330 at firing range 48	13
5. Analytical results for sample size/heterogeneity study using surface soils	16
6. Analysis of airborne dust from Fort Ord and CFB-Valcartier soils	17
7. HMX concentrations from extraction time study using acetone	18
8. Assessment of on-site methods for RDX and HMX in Fort Ord soil samples	18
9. Results for assessment of composite preparation method	20

Site Characterization for Explosives Contamination at a Military Firing Range Impact Area

THOMAS F. JENKINS, MARIANNE E. WALSH, PHILIP G. THORNE,
PAUL H. MIYARES, THOMAS A. RANNEY, CLARENCE L. GRANT,
AND JOHN R. ESPARZA

INTRODUCTION

Background

A study conducted in 1994 by the Army revealed that the impact areas at the inland firing ranges of Fort Ord were contaminated with residues of high explosives. The contaminant present at the highest concentration was HMX (octahydro-1,3,5,7-tetranitro-1,3,5,7-tetrazocine), with much lower concentrations of RDX (hexahydro-1,3,5-trinitro-1,3,5-triazine), TNT (2,4,6-trinitrotoluene), and two known environmental transformation products of TNT—4-amino-2,6-dinitrotoluene (4-AmDNT) and 2-amino-4,6-dinitrotoluene (2-AmDNT)—also being found (Fig. 1). The ranges had been actively used at the time of this study. One soil had an HMX concentration as high as 1100 mg/kg, but, even in this sample, the concentration of RDX was only 11 mg/kg. However, the number of soil samples analyzed in the 1994 study was quite limited relative to the size of the impact areas, and the study was not designed to provide sufficient spatial resolution to delineate the extent of cleanup required from either a depth or a surface area perspective. Ranges 44 and 48 in site 39 were identified as areas of concern (Fig. 2). Recent results obtained by IT Corporation, but with incomplete documentation, indicated that RDX was not detectable in the soil samples that they collected in 1997, while HMX remained the predominant high explosive present.

From a human health perspective, HMX was not thought to be a major problem and remediation goals were developed based on RDX. For example, comparative drinking water criteria for HMX, RDX, and TNT are shown in Table 1 (EPA 1996). In addition, the 1994 study thought that HMX and RDX would be co-resident and that targeting soils with concentrations of RDX above 0.5 mg/kg

would coincidentally target soils with the highest levels of HMX. Comparative environmental risk factors were not evaluated, though.

Our experience from an earlier investigation at CFB-Valcartier (Canadian Force Base) shows that the concentrations of residues on impact ranges are highly correlated with individual tank targets (Fig. 3, Jenkins et al. 1997a). Like Fort Ord, the major residual contaminant at CFB-Valcartier was HMX because 66-mm M72 LAWs (Lightweight Anti-Armor Weapons, Fig. 4) were extensively used. These rockets contain octol, a melt cast explosive composed of a 70:30 mixture of HMX and TNT. Inspection of debris at ranges 44 and 48 at Fort Ord, and discussions with explosives ordnance disposal (EOD) personnel, told us that the LAW was used extensively. Unlike CFB-Valcartier, various other ordnance was fired as well, including many munitions that contained Composition B, which is made of RDX and TNT.

One important criterion that must be specified, before decisions can be made about the need to remediate specific locations within the site, is the depth interval in the soil that is subject to the 0.5-mg/kg cleanup criterion for RDX. Our experience at CFB-Valcartier, and at other areas contaminated by explosives, suggests that there is a marked concentration gradient for explosives contaminants as a function of depth, the highest concentrations being in the top 2 in. (5 cm) of soil (Jenkins et al. 1996, 1997a). This is true because explosives are solids at ambient temperature and were deposited on the site as small particles. Samples analyzed for the 1994 study were reported at two depths, 0 and 2.5 ft (0 and 0.8 m). It is uncertain whether these samples were vertical composites over the 0- to 2.5-ft and 2.5- to 5-ft (0.8- to 1.6-m) intervals, or over smaller depth intervals, near 0 and 2.5 ft. Because of the concentration gradient often found

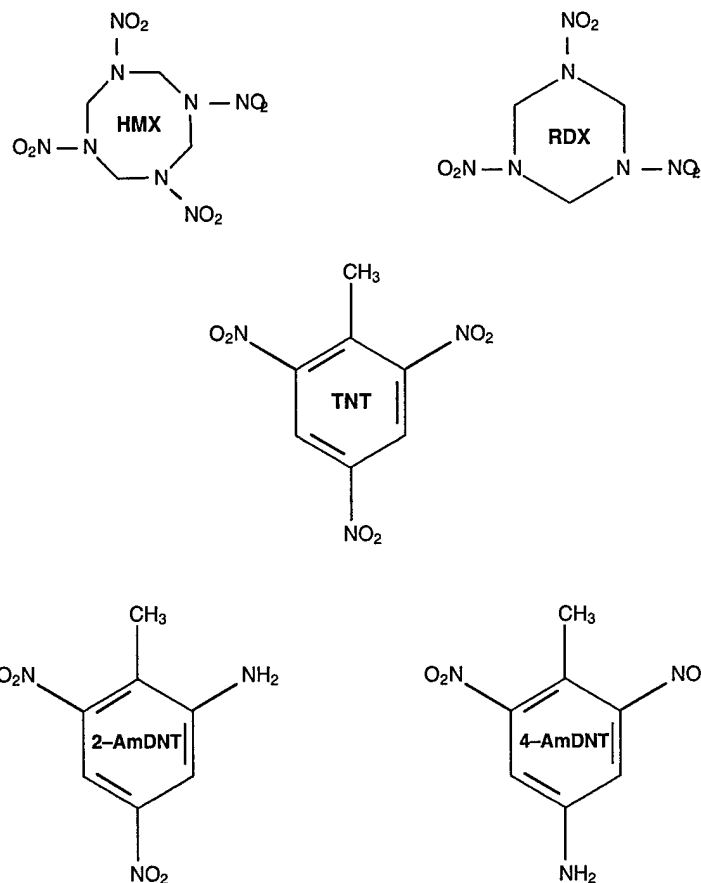

Figure 1. Structures of explosives detected at the Fort Ord inland firing ranges.

for these compounds, and also identified for the two depth intervals sampled in the 1994 Army study at Fort Ord, it is important to specify exactly over what depth interval the 0.5-mg/kg concentration applies. Inclusion of soil from depths below 5 cm will probably reduce measured concentrations by dilution with soil containing much lower concentrations of RDX.

A major complicating factor for both site characterization and excavation for cleanup at impact areas is the potential presence of unexploded ordnance (UXO) at and below the surface. EOD personnel must clear the surface for us to gain access to sites, and, before sampling activities can take place, clear UXOs at depth. This requirement will be a major factor in the time and costs of sample collection and excavation for specific areas targeted for cleanup. To allow sampling at depth near tank targets, EOD personnel will need to manually excavate the soil to the depth of interest to ensure that no UXO is present. Doing this will mix the soil within the depth profiles and destroy depth-specific information. It is possible, though,

to work with EOD personnel to develop a procedure that takes advantage of the clearance activities to provide unmixed soil depth samples. The protocol must also provide procedural guidance if chunks of explosive are encountered, and when intact UXO is discovered.

Objective

This project has three major objectives. The first was to provide information to the U.S. Army Engineer District, Sacramento, on the current status of explosives contamination at Fort Ord's inland impact ranges. This will include data on the areal and vertical extent of explosives contamination at several selected locations near specific tank targets, obtained 4 years after the 1994 study. The second objective was to develop a specific set of protocols to be used for more extensive site characterization that:

- Specify the method for collection and homogenization of discrete soil samples.
- Assess the need for preparing composite

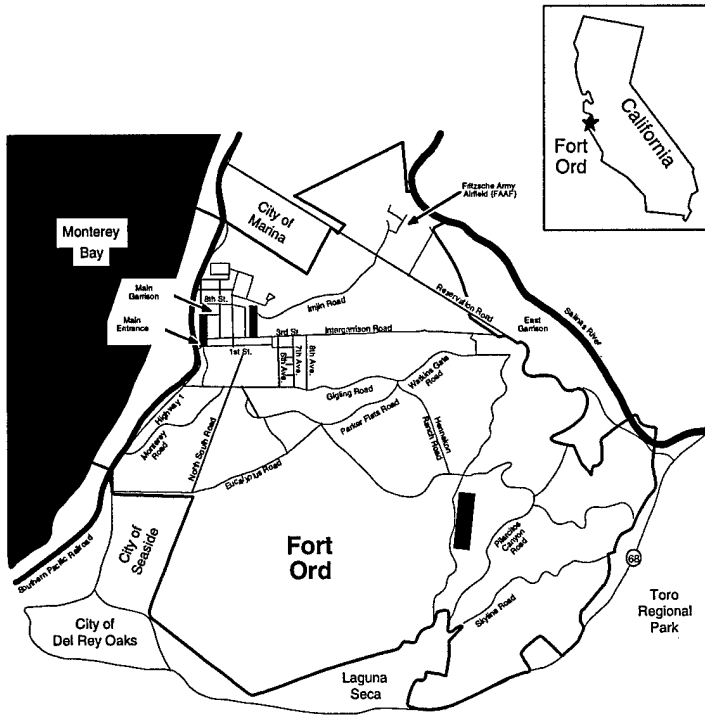

a. Location.

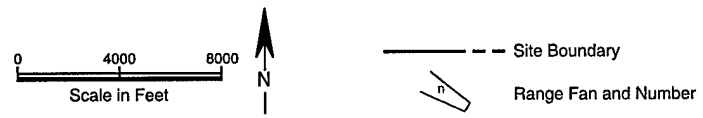
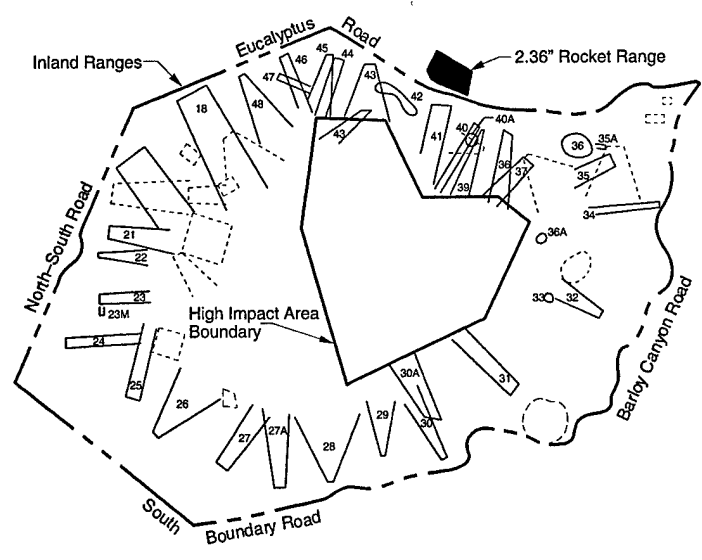

b. Firing ranges.

Figure 2. Fort Ord.

Table 1. Water quality criteria for selected explosives.

Compound	Health advisory criteria (70-kg adult)*			
	Longer term† (mg/L)	DWEL** (mg/L)	Lifetime†† (mg/L)	Cancer risk*** at 10 ⁻⁴ (mg/L)
HMX	20	2	0.4	—
RDX	0.4	0.1	0.002	0.03
TNT	0.2	0.02	0.002	0.1

* Taken from EPA (1996).

† Concentration that is not expected to cause any adverse noncarcinogenic effects up to 7 years of exposure, with a margin of safety.

** Drinking water equivalent level. A lifetime exposure concentration protective of adverse, noncarcinogenic health effects. Assumes all exposure is through drinking water.

†† The concentration of a chemical that is not expected to cause any adverse noncarcinogenic effects over a lifetime of exposure, with a margin of safety.

*** TNT and RDX are in cancer group C (limited evidence from animal studies and inadequate or no data in humans) and HMX is in cancer group D (inadequate or no human or animal evidence of carcinogenicity).

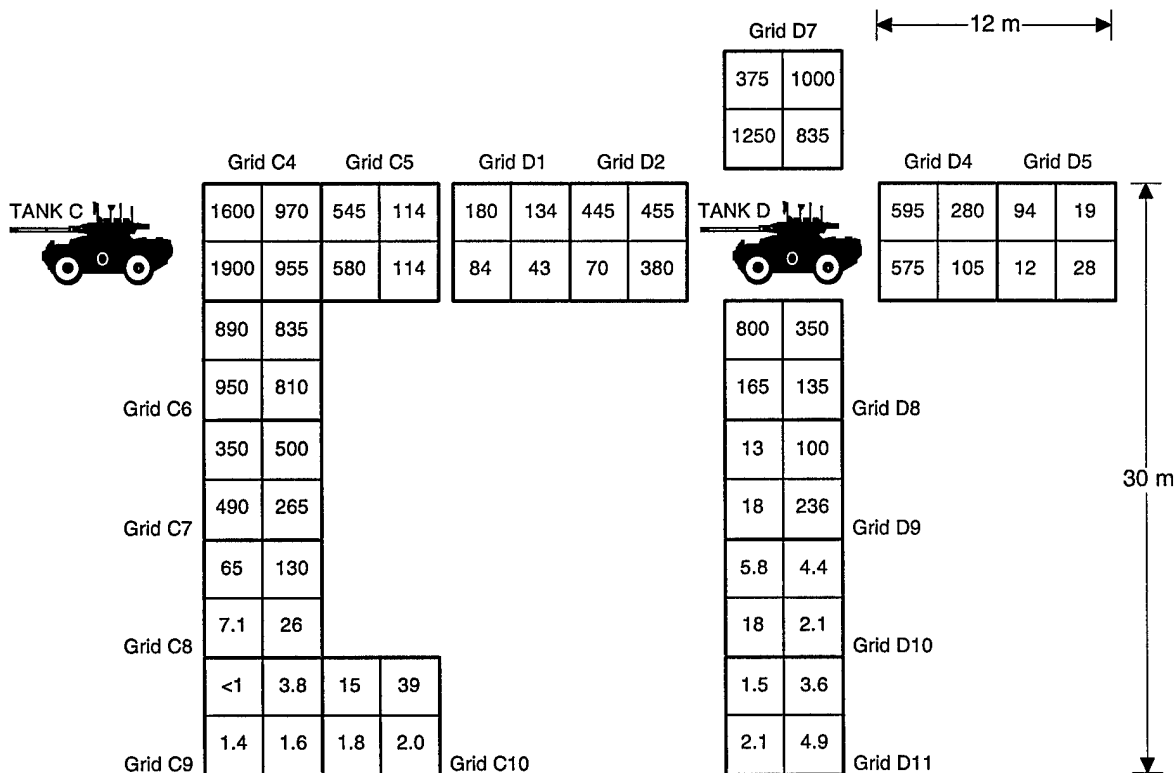

Figure 3. HMX concentrations (mg/kg) in soil at Canadian Force Base-Valcartier firing range, relative to placement of tank targets.

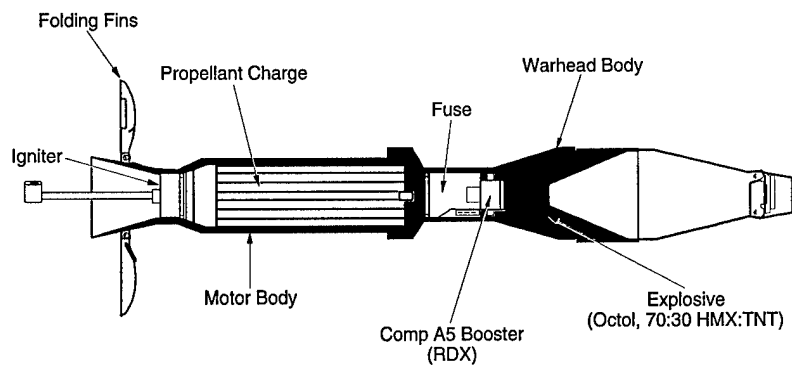

Figure 4. 66-mm M72 LAW rocket.

samples and the manner of preparing composites to better provide representative samples for specific areas within the impact ranges.

- Specify analytical protocols to estimate concentrations of target analytes within these samples.
- Provide statistical criteria to use when comparing results to the cleanup levels established for impact ranges at Fort Ord.

The third objective was to evaluate a draft protocol that we have developed for conducting preliminary site assessments that can be used to prepare a full-scale sampling plan that is tailored to the specific contamination profile at the site under investigation (App. A). In addition, we intend to provide the Sacramento District with information, developed since the 1994 study was completed, that might be relevant to this problem.

EXPERIMENTAL METHODS

Sampling design

The following sampling design was developed to evaluate the relationship between residual contaminants at the inland ranges and the placement of tank targets. Ranges 44 and 48 were selected (Fig. 2b) because they had the highest concentrations of HMX, RDX, TNT, 4-AmDNT, and 2-AmDNT reported in the 1994 study.

Location 1-44

In range 44, the area having the highest concentration of explosives residues in the 1994 study was selected for further investigation (Fig. 2b). This area is adjacent to a tank target that was extensively used, as evidenced by the large amount of debris located around it. This area is designated as location 1-44. Based on our previous experi-

ence at a similar site at CFB-Valcartier (Jenkins et al. 1997a), four 5- × 5-m sampling grids were established near the tank target (Fig. 5). Grid A was just in front of the tank (between the tank and the firing positions), with its edge up against the side of the target vehicle. Grid B was positioned 5 m to the left of the target (as you face the target from the firing positions) and encompassed a 25-m² area ranging from 5 to 10 m from the target. Similarly, grid C was placed 10 m behind the target and grid D was 15 m to its right, as shown in Figure 5.

Within each grid, a diagonal line was drawn from the left front corner to the right rear corner. Two positions were chosen along this diagonal—one-third and two-thirds of the distance along it. At each position, two sampling points were selected—0.5 m to each side and perpendicular to the diagonal. In this way, four sampling points were established within each grid (Fig. 6). Our numbering system for the four samples from the grid nearest the target is 1-44-1 through 1-44-4. Likewise, samples 1-44-5 through 1-44-8 are from the grid offset 5 m to the left of the target, samples 1-44-9 through 1-44-12 are from the grid 10 m behind the target, and samples 1-44-13 through 1-44-16 are from the grid 15 m to the right of the target.

Location R-44

At range 44, one 5- × 5-m background grid, designated R-44, was located behind the major firing position so that it would have no residues originating from nearby detonations. This location served as a background sampling area. Four sampling points were established in grid R-44 as described for 1-44 above.

Location 1-48

Three sampling locations were established within range 48. The first, designated 1-48, was adjacent to a tank target. Four grids, each with four sampling points, were established for 1-48 in an

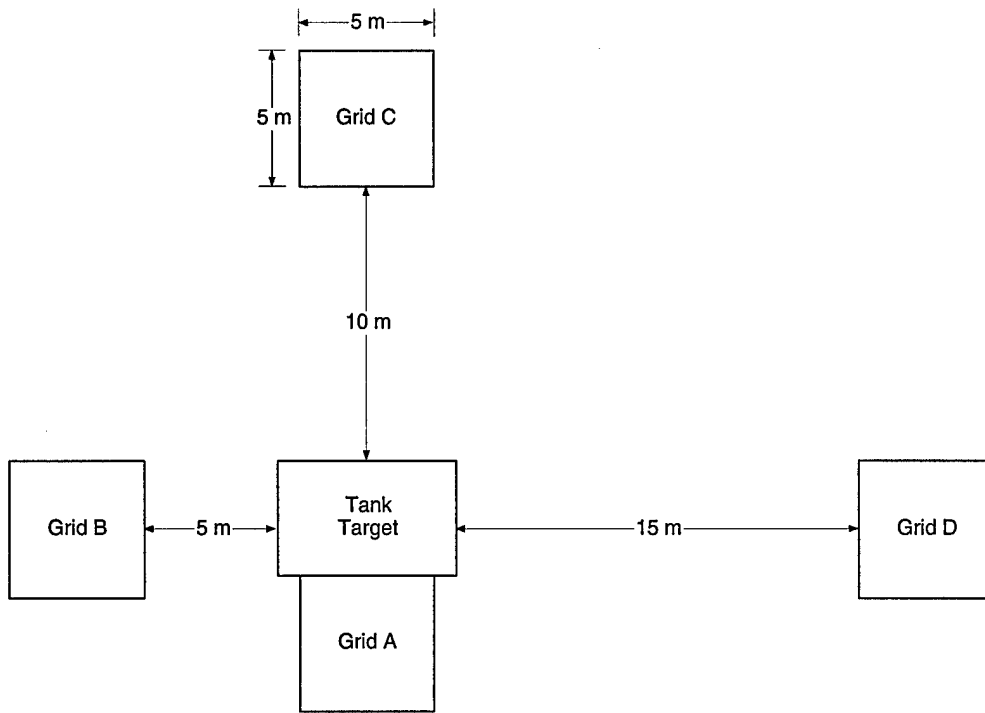

Figure 5. Sampling grids for area 1-44.

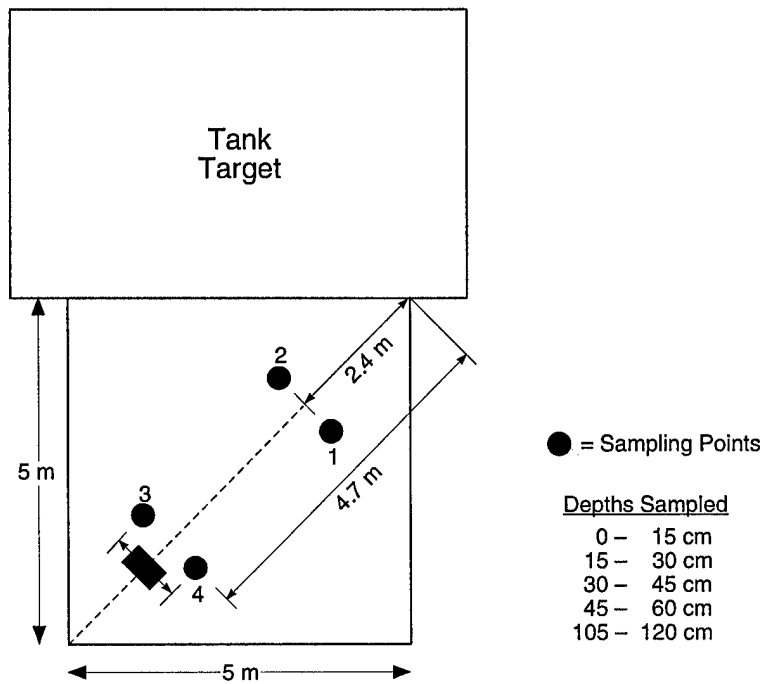

Figure 6. Locations of sampling points within a grid.

identical manner as described for 1-44 (Fig. 5). From the condition of the target vehicle and the concentration of surface debris, we thought that this area had much less use than did the corresponding target in range 44.

Location 2-48

We established a second range 48 location, designated 2-48, next to an abandoned target area. A.R. Smith and personnel from CMS Corporation told us that a target vehicle had been located here, some time past, but it had subsequently been removed. The large pieces of a target vehicle that littered the immediate vicinity provided evidence for this conclusion. The ordnance debris was largely from mortar rounds, which are typically filled with Composition B. No debris from 66-mm M72 LAW rockets was observed at this site, indicating that it was an older target area, used before the LAW rockets were introduced. Four sampling grids were established adjacent to this location in an identical manner to those in 1-44 and 1-48.

Location R-48

The third sampling location in range 48 was in an area that was free of target debris and had a low concentration of munitions debris. This location was surrounded by target vehicles, the closest being about 30 m distant. Thus, soil samples from this sampling location served to indicate the level of residual contaminants in the firing range at large, but at a distance from individual target vehicles. A single 5- × 5-m grid was established at this position, with four sampling points located as described above. This location was designated as R-48.

Soil sample collection

All soil samples were collected by EOD personnel from CMS Corporation. At all designated sampling points, soil was excavated by hand digging in 15-cm-depth intervals. The soil for a given depth interval was mixed in place with a small hand-held shovel. This method worked well for the dry, sandy soils at this location and it minimized the need for collecting very large portions in a separate container. Approximately 1 kg of material was shoveled into a 1-gal. Zip-Loc™ bag. The bag was closed and the remaining soil from that depth interval was removed from the hole. The EOD individual then treated the soil from the next depth interval identically, being careful that material from the sides of the hole did not fall in from above. This kept soils collected at depth from being contaminated by material from nearer the surface. Samples were collected from the following depths

at each sampling location: 0-15 cm, 15-30 cm, 30-45 cm, and 45-60 cm. A fifth sample from a 105- to 120-cm depth interval was collected with a post hole digger, after the 45- to 60-cm-depth sample had been removed. In all, 280 soil samples were collected from 14 grids containing 56 sampling points by two CMS sampling teams in a period of a day and a half.

We should note that Zip-Loc plastic bags were used for sample collection, rather than glass bottles, for two reasons. First, our experience told us that rather large samples with substantial homogenization were necessary to produce representative subsamples for discrete locations. This was much easier to accomplish using plastic bags. Secondly, collecting samples in an area contaminated with UXO was much easier to do using plastic bags. Research conducted by Parker et al. (1990) has demonstrated that polynitroaromatics and nitramines do not sorb strongly to plastics. In addition, we did not observe any tendency of fine particles to adhere to the inner surfaces of the bags.

Homogenization and subsampling for discrete soil samples

Surface (0- to 15-cm) samples were returned to CRREL in their entirety. For other samples, we homogenized the soil in the bags, in an area just off the firing range, by shaking and pouring the material within the bag. A subsample of several hundred grams was then retained and shipped to CRREL for analysis.

Once at CRREL, the samples were further homogenized by shaking and pouring within the bags, and a 35-g sample was removed and air-dried overnight in weigh boats. Because there had been little or no rainfall at Fort Ord for some time prior to sampling, and since the soil there is largely fairly coarse sand, the soils from the first four depth intervals were quite dry. Soil from the 105- to 120-cm depth had a higher moisture content, but even so, it was generally only about 3% on a dry weight basis.

After dry weights were obtained, air-dried soils were further homogenized by thoroughly mixing the material in the weigh boats with a spatula. A 2.00-g portion was then placed in a 22-mL glass scintillation vial for extraction and analysis by reversed-phase high-performance liquid chromatography using a UV detector at 254 nm (RP-HPLC-UV) (SW-846 Method 8330). Several duplicate samples were prepared, as well, for each batch of soils processed. The remaining material was retained in 22-mL glass vials for additional characterization.

Preparation of discrete samples used to assess the effect of sample size on heterogeneity

The samples used for this study were from the 0- to 15-cm depth of 1-44-8 and 1-44-11. Each sample's material was placed in an aluminum pan and coned and quartered, as described elsewhere (Jenkins et al. 1996). Approximately 100 g of soil was removed from each quarter to prepare a 400-g sample, which was placed in another pan.

The material in the second pan was again mixed thoroughly and a set of five replicate 20-g portions and five replicate 7.5-g portions were weighed into individual 125-mL Nalgene bottles. The remainder of the material was split in half. From one half, five 2.0-g and five 0.5-g portions were weighed into individual glass vials. The other half was ground with a mortar and pestle and five 2-g portions were weighed into individual glass vials.

All of these samples were extracted with acetonitrile and analyzed using the laboratory HPLC method described below. The volume of acetonitrile/soil weight ratio was 100 mL for 20-g samples, 40 mL for 7.5-g samples, 10 mL for 2-g samples, and 3 mL for 0.5-g samples.

Preparation of composite samples

Depth-based composite samples were prepared from the 0- to 15-cm, 30- to 45-cm, and 105- to 120-cm depths for samples from the four grids in area 1-44. For a given depth for each of the four discrete samples within a grid, 100-g portions of the soil from the plastic bag were weighed into an aluminum pan and the material was mixed, coned, and quartered. A 5-g portion was taken from each quarter and combined to form a 20-g composite.

For comparison, a discrete 20-g sample was taken for each of the 16 discrete surface (0- to 15-cm) samples from area 1-44. The 12 composites and 16 discrete surface samples were extracted with acetone for 10 minutes and the extracts were analyzed using a colorimetric on-site method, as described below.

Collection and analysis of dust samples

The soils from Fort Ord produced a large amount of fine dust when they were homogenized and subsampled. A sample of this airborne dust was collected on a filter as follows. A pre-weighed 0.45- μ m Nuclepore filter was placed in a filter cassette and a vacuum hose was attached. The soil sample in a plastic bag was shaken vigorously and the dust was allowed to settle for about 10 seconds. Then, the filter cassette was placed in the

mouth of the bag and air was drawn through it until the filter became visually darkened (approximately 10 seconds). The filter was removed and reweighed to establish the mass of dust of collected (about 100 mg). The filter was then folded and placed in a 22-mL scintillation vial and extracted with acetonitrile as described below for soil samples. Two samples were tested: one was a composite sample from grid A (0- to 15-cm depth) 1-44, and the other was a surface composite from CFB-Valcartier.

Soil sample extraction and HPLC analysis (SW-846 Method 8330)

A 10.0-mL aliquot of acetonitrile was added to each vial containing a 2.00-g portion of air-dried soil. In batches of 25, these samples were shaken manually to disperse the material and then placed in an ultrasonic bath for 18 hours (EPA 1994). The bath was maintained at room temperature with cooling water throughout. In each sample batch, one was selected to serve as an extraction and analysis control sample. A separate portion of this sample was spiked with a multi-analyte solution and processed along with the unfortified samples. On a dry soil basis, the spiked concentration for HMX, RDX, DNB, TNB, NB, TNT, 2-AmDNT, and 2,4-DNT was approximately 0.5 mg/kg.

Following sonication, the samples were allowed to settle for at least 15 minutes. A 5.00-mL aliquot was removed via a glass volumetric pipette and mixed with a 5.00-mL portion of aqueous CaCl₂ (4 mg/L). The solution was shaken and allowed to stand for at least 15 minutes to allow flocculation and settling. A portion of this solution was then filtered through a Millex SR filter. The resulting sample extract was maintained at 4°C in the dark.

All soil extracts were analyzed by RP-HPLC-UV as described in SW846 Method 8330. We did the initial analysis on an LC-18 column (Supelco) in batches, using eluent composed of 1:1 methanol/water at a flow rate of 1.5 mL/min. Calibration standards and spiked control samples were run with each batch to ensure that the analysis was in control. Chromatograms were individually inspected and target analytes identified. Samples where a potential target analyte was detected were reanalyzed on an LC-CN (Supelco) column as specified in SW846 Method 8330 to confirm analyte identities. We report quantitative results from peak height measurements on the LC-CN column because only five analytes were detected

(HMX, RDX, TNT, 4-AmDNT, and 2-AmDNT) and much better resolution for these target analytes was obtained on the LC-CN column as compared to the LC-18.

Extraction time assessment and evaluation of on-site methods for RDX and HMX

An initial experiment was conducted to determine the effect of various extraction times on recovery of HMX for soil samples from Fort Ord. Three discrete samples from location 1-44-1 were selected for this evaluation: one from the 0- to 15-cm depth, one from the 30- to 45-cm depth, and one from the 105- to 120-cm depth. A 20-g portion of each was placed in individual plastic extraction bottles and 100 mL of acetone (3% water) was added. The samples were shaken manually for 3 minutes, and, after approximately 1 minute of settling, we removed a 2-mL aliquot and filtered it through a 0.5- μ m Millex SR filter. The bottles were then given an additional 7 minutes of shaking and another 2-mL aliquot was removed in a similar manner. We then shook the bottles for an additional 20 minutes, and removed a 2-mL aliquot, which was processed as above. Thus, three aliquots representing 3-, 10-, and 30-minute shaking periods were collected from each soil. These samples were diluted 1:5 with reagent grade water and analyzed by RP-HPLC-UV on an LC-CN column as described above.

In a second experiment, we selected a set of 11 soil samples to assess the usefulness of the two commercially available on-site RDX methods for analysis of the soil samples. For each soil selected, a 20-g portion of field-moist soil was placed in a plastic bottle and 100 mL of acetone (3% water) was added. The bottles were shaken periodically over 30 minutes and the soil particles were allowed to settle for at least 15 minutes. A 50-mL aliquot was then withdrawn with a Plastipak syringe and filtered through a Millex SR filter. The resulting acetone extract was analyzed by three methods: 1) RP-HPLC using the LC-CN column, 2) a colorimetric method available from EnSys (now Strategic Diagnostics Corp.) (Jenkins and Walsh 1992), and 3) a DTECH enzyme immunoassay method from Strategic Diagnostics.

For HPLC analysis, each acetone extract was diluted 1:5 with deionized water prior to injection. This was done to ensure that the solvent strength of the injected sample was lower than the eluent to maintain adequate peak shape.

RESULTS AND DISCUSSION

Analytical results for RP-HPLC analysis of all soil samples are presented in Appendix B. Table B1 provides the results for sampling location 1-44. Likewise, Tables B2-B5 give results for sampling locations R-44, 1-48, 2-48, and R-48, respectively. Table B6 presents the results for spiked samples analyzed to assess recovery of target analytes.

Overview of explosives detected in the various sampling areas

By far, the greatest concentration of explosives residues was detected in range 44, sampling location 1-44. HMX was detected at the highest concentration, with up to 587 mg/kg in the surface soil (Table 2). Concentrations of RDX, TNT, 4-AmDNT, and 2-AmDNT were also detected in area 1-44, but the maximum values obtained for these analytes were only 1.70, 0.59, 1.46, and 1.31 mg/kg, respectively (Table 3). No other explosives-related compounds were detected in any samples from the inland firing ranges at Fort Ord.

Some explosives residues were also detected at sampling area 1-48, although concentrations were very low compared with those found in area 1-44 (Table 4). The maximum values found among the 80 soil samples analyzed from area 1-48 for HMX, RDX, TNT, 4-AmDNT, and 2-AmDNT were 1.43, 0.46, 0.01, 0.08, and 0.09 mg/kg, respectively; the latter three values are estimates that were below method detection limits (MDLs).

Very low concentrations of TNT, 4-AmDNT, and 2-AmDNT were occasionally detected in the 80 soil samples from sampling area 2-48, but neither RDX nor HMX was detected. Maximum values were all below MDLs of 0.2 mg/kg, however. No explosives residues were detected in any of the 40 soil samples from sampling areas R-44 or R-48.

Depth of contamination

Since explosives residues were almost exclusively confined to areas 1-44 and 1-48, the following discussions concerning the depth of contamination will concentrate only on these areas.

In area 1-44, HMX concentrations were greatest by far in the surface 0-15 cm (Table 2). In grid A, the sampling grid nearest the tank target, the mean concentration of HMX in the 0- to 15-cm depth was 295 mg/kg, while mean concentrations in the 15- to 30-cm, 30- to 45-cm, 45- to 60-cm, and 105- to 120-cm depth intervals were 1.65, 0.62, 0.37, and

2.52 mg/kg, respectively (Fig. 7a). In grid B, mean concentrations declined with depth as well. Mean concentrations of HMX in grid C were again much higher in the surface soil (109 mg/kg) than at depth. Concentrations of HMX in grid D were much lower in the surface (1.44 mg/kg) than in the grids nearer the target and, with only one exception, undetectable in subsurface soils.

Mean concentrations from the 105- to 120-cm depth in both grids A and B from sampling areas 1-44 showed higher concentrations of HMX than samples from either the 30- to 45-cm or 45- to 60-cm depths. However, the differences were not statistically significant, owing to the very large variations in results for the 105- to 120-cm depth. The reason for this anomalous result is uncertain, but the deepest soils had substantially higher mois-

ture contents than soils samples from shallower depths. Whether the higher concentrations found at 105-120 cm are connected with the higher moisture contents is uncertain. Remember, the deepest samples were collected differently from those at the surface through 60 cm because it was impractical to excavate to this depth in a soil profile consisting of dry sands. Thus, it is possible that some of these deep samples may have been inadvertently contaminated by surface material. Since some individual deep samples showed no increase in concentration, while adjacent samples showed large increases, this explanation should be considered in planning future tests.

Concentrations of RDX (Fig. 7b), TNT (Fig. 7c), 4-AmDNT, and 2-AmDNT were largely detected in soil from the 0- to 15-cm depth in sampling area

Table 2. Concentrations of HMX (mg/kg) by SW-846 Method 8330 at firing range 44 (location 1-44).

Sample	0-15 cm	15-30 cm	30-45 cm	45-60 cm	105-120 cm
Grid A					
1-44-1	273 (250)*	0.68	0.65	0.70	7.01
1-44-2	302	1.00	0.41	0.25	0.37
1-44-3	479	4.29	1.31 (0.81)	0.24	2.01
1-44-4	136	0.62	0.35	0.30	0.69
Mean ± std. dev.					
1-4	295 ± 142	1.65 ± 1.77	0.62 ± 0.32	0.37 ± 0.22	2.52 ± 3.08
Grid B					
1-44-5	587	1.29	0.35	0.30	1.33 (1.36)
1-44-6	269	45.1	0.78	0.31	4.91 (1.36)
1-44-7	343	0.79	0.55	0.31	7.73
1-44-8	81.4 (75.1)	26.8 (49.8)	0.83	0.24	0.28
Mean ± std. dev.					
5-8	320 ± 246	18.5 ± 21.5	0.63 ± 0.22	0.29 ± 0.03	3.12 ± 3.29
Grid C					
1-44-9	20.2	0.16	0.09	0.05	ND
1-44-10	36.1	0.39	0.33	0.51	0.29
1-44-11	204 (409)	10.4	2.56	0.49	1.30
1-44-12	74.3	0.21 (0.24)	ND	ND	0.45 (0.19)
Mean ± std. dev.					
9-12	109 ± 133	2.79 ± 5.07	0.73 ± 1.22	0.26 ± 0.28	0.48 ± 0.57
Grid D					
1-44-13	0.45 (0.19)	ND	—	ND	ND
1-44-14	4.28	ND	ND	ND	ND
1-44-15	ND† (0.48)	0.64	ND	ND	ND
1-44-16	0.27 (1.56)	ND	ND	ND	ND
Mean ± std. dev.					
13-16	1.44 ± 1.92	0.16 ± 0.32	ND	ND	ND
Grand mean	173	5.1	0.50	0.23	1.53

* Duplicate subsample.

† Not detectable.

1-44 (Table 3). The maximum concentration of RDX in these surface samples was 1.7 mg/kg, and only one other sample had a concentration above 1 mg/kg. These RDX concentrations appear to be much lower than those obtained for the 1994 study, indicating that RDX concentrations have declined in these surface soils with time.

The maximum concentrations of HMX residues in surface soils were two to three orders of magnitude lower in sampling area 1-48 than in sampling area 1-44 (Table 4). RDX concentrations were also slightly lower, but penetrated deeper than observed in 1-44 into the soil profile in three samples. For example, RDX concentrations of 0.44 and 0.40 mg/kg were found at the 45- to 60-cm depth interval for sampling points 1-48-1 and 1-48-2. These samples, you will recall, are within

a few meters of the target location, an area that probably experienced an enormous number of local detonations. This disturbed the soil profile substantially, perhaps mixing the soil in the top 60 cm.

Areal distribution of contaminants

The distribution of HMX in the surface soils for sampling area 1-44 is shown in Figure 8a. Mean concentrations plus or minus standard deviations for the 0- to 15-cm layers in grids A, B, C, and D were 295 ± 142 , 320 ± 246 , 109 ± 133 , and 1.44 ± 1.92 mg/kg, respectively (Table 2). Thus, concentrations of HMX in the surface soils decline beyond 10 m from the target, but not as quickly as we found at CFB-Valcartier (Fig. 3, Jenkins et al. 1997a). Concentrations of RDX (Fig. 8b), TNT (Fig. 8c), 4-AmDNT, and 2-AmDNT were detected in

Table 3. Concentrations of RDX, TNT, 4-AmDNT, and 2-AmDNT (mg/kg) by SW-846 Method 8330 in surface (0-15 cm) soils at firing range 44 (location 1-44).

Sample	RDX	TNT	4-AmDNT	2-AmDNT
Grid A				
1-44-1	0.50 (1.70)*	0.10 (0.59)	1.08 (1.46)	0.90 (1.31)
1-44-2	0.55	0.05	1.24	0.99
1-44-3	0.19	0.23	0.43	0.20
1-44-4	0.09	0.06	0.69	0.58
Mean \pm std. dev				
1-4	0.29 ± 0.20	0.17 ± 0.14	0.91 ± 0.42	0.72 ± 0.41
Grid B				
1-44-5	0.26	0.06	0.47	0.36
1-44-6	0.43	ND†	0.69	0.58
1-44-7	0.37	0.53	0.49	0.41
1-44-8	0.08 (0.08)	0.03 (0.03)	0.23 (0.20)	0.20 (0.16)
Mean \pm std. dev.				
5-8	0.20 ± 0.14	0.16 ± 0.25	0.47 ± 0.19	0.38 ± 0.16
Grid C				
1-44-9	ND	ND	0.10	0.07
1-44-10	ND	ND	0.15	0.19
1-44-11	ND (0.29)	0.06 (0.09)	0.30 (0.36)	0.20 (0.25)
1-44-12	1.14	0.24	0.37	0.48
Mean \pm std. dev.				
9-12	0.32 ± 0.55	0.08 ± 0.11	0.24 ± 0.13	0.24 ± 0.17
Grid D				
1-44-13	ND	ND	ND	ND
1-44-14	ND	ND	0.03	ND
1-44-15	ND	ND	ND	ND
1-44-16	ND	ND	ND	ND
Mean \pm std. dev.				
9-12	ND	ND	ND	ND

* Duplicate subsample.

† Not detectable.

a. HMX.

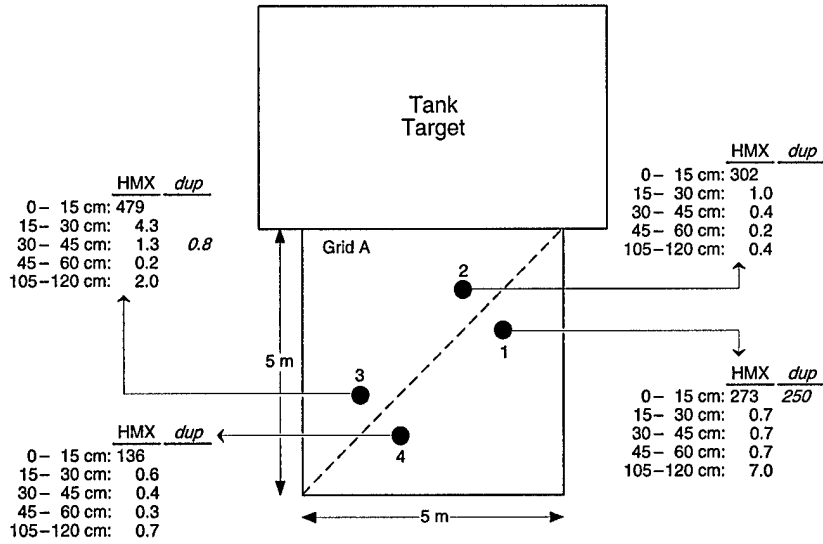

b. RDX.

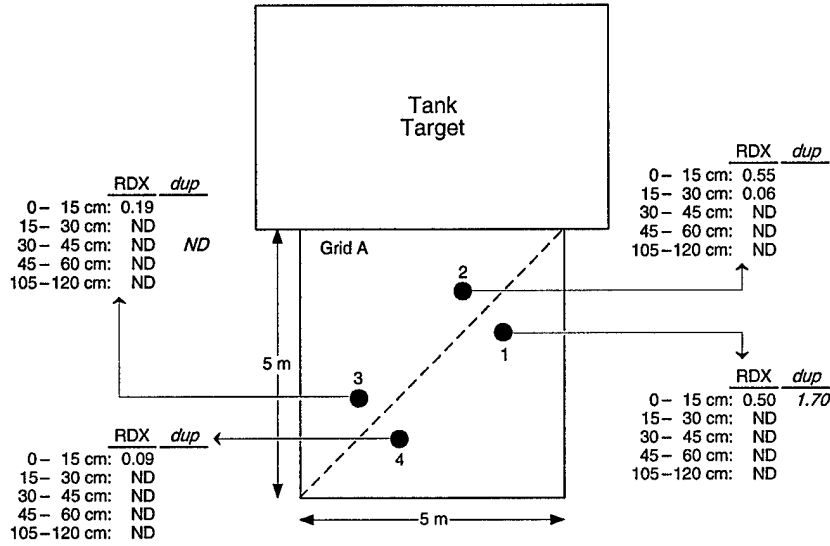

c. TNT.

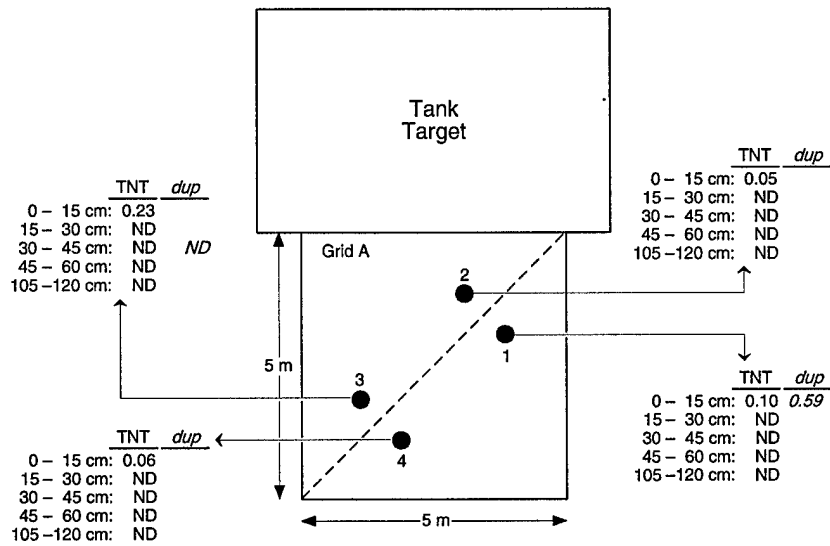

Figure 7. Concentrations (mg/kg) of explosives residues as a function of depth for grid A, sampling location 1-44.

Table 4. Concentrations of HMX and RDX (mg/kg) by SW-846 Method 8330 at firing range 48 (location 1-48).

Sample	0-15 cm	15-30 cm	30-45 cm	45-60 cm	105-120 cm
HMX					
1-48-1	1.43	0.38	1.18	0.26	0.39
1-48-2	1.17	0.40	0.96	0.29	0.58
1-48-3	0.05	ND*	ND	ND	0.31
1-48-4	ND	ND	0.10	ND	ND
1-48-5	1.07	0.68	0.16	0.41	ND
1-48-6	0.34	0.17	0.27	ND	ND
1-48-7	ND	0.19	0.14	ND	ND
1-48-8	ND	0.22	ND	ND	ND
1-48-9	ND	ND	ND	ND	ND
1-48-10	ND	ND	ND	ND	ND
1-48-11	ND	ND	ND	ND	ND
1-48-12	ND	ND	ND	ND	ND
1-48-13	ND	ND	ND	ND	ND
1-48-14	ND	ND	ND	ND	ND
1-48-15	ND	ND	ND	ND	ND
1-48-16	ND	ND	ND	ND	ND
RDX					
1-48-1	0.23	0.16	0.18	0.44	ND
1-48-2	0.07	0.12	0.19	0.40	0.15
1-48-3	0.08	ND	ND	ND	0.05
1-48-4	ND	0.11	ND	ND	ND
1-48-5	ND	ND	ND	ND	ND
1-48-6	ND	ND	ND	ND	ND
1-48-7	ND	ND	ND	ND	ND
1-48-8	ND	ND	ND	ND	ND
1-48-9	ND	ND	ND	ND	ND
1-48-10	ND	ND	ND	ND	ND
1-48-11	ND	ND	ND	ND	ND
1-48-12	ND	ND	ND	ND	ND
1-48-13	ND	ND	ND	0.46	ND
1-48-14	ND	ND	ND	ND	ND
1-48-15	ND	ND	ND	ND	ND
1-48-16	ND	ND	ND	ND	ND

*Not detectable.

about equal concentrations in grids A, B, and C, but mean concentrations were always less than 0.4 mg/kg for RDX and TNT, and less than 1.0 mg/kg for the 4- and 2-AmDNTs (Table 3).

In sampling area 1-48, explosives residues were found consistently at very low concentration in grid A, just adjacent to the tank. Again HMX had the highest concentration, but here the maximum value detected was only 1.43 mg/kg (Table 4). Very low concentrations of HMX were also detected in grid B, but HMX was not detected in any samples

from grids C and D. RDX was only detected in surface samples from grid A at sampling location 1-48, and the maximum RDX concentration was only 0.44 mg/kg; TNT, 2-Am-DNT and 4-Am-DNT were also occasionally detected in soils from location 1-48, but all concentrations were below 0.1 mg/kg.

Overall, these results confirm that the concentration of explosives residues in soils at the inland firing ranges is related to the proximity of targets. In addition, it appears that the concentrations

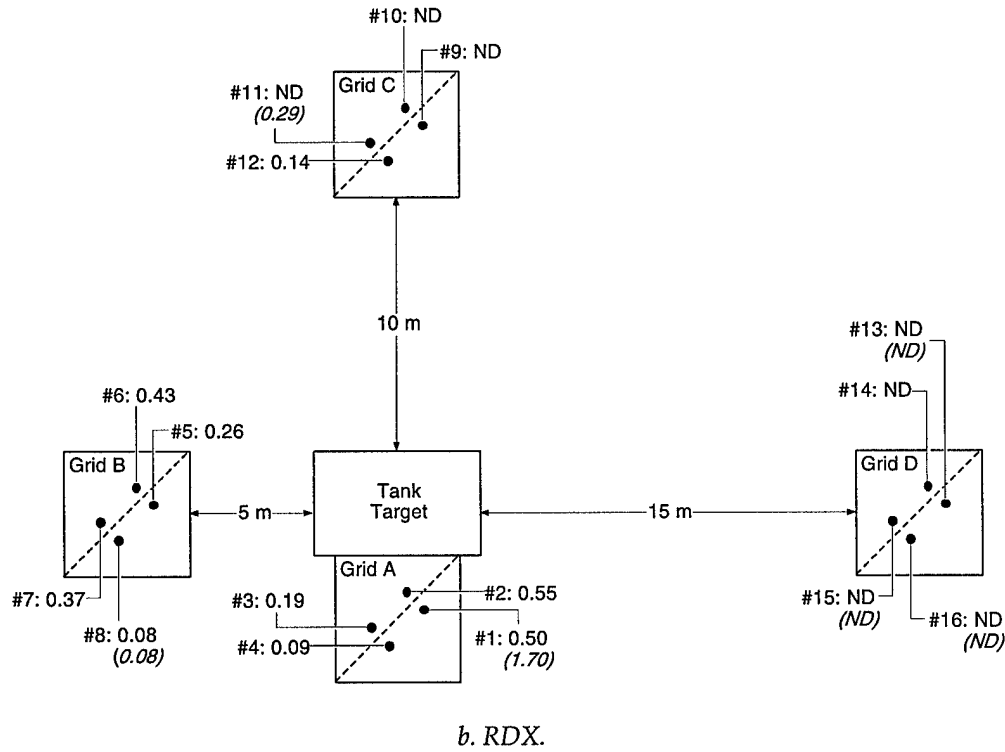
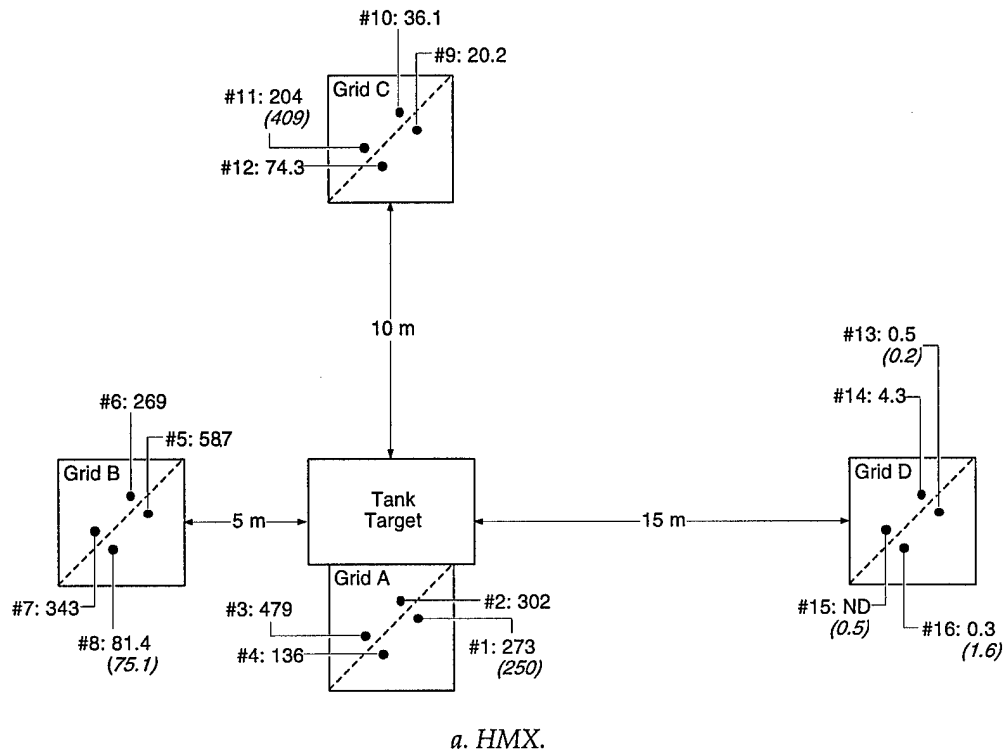
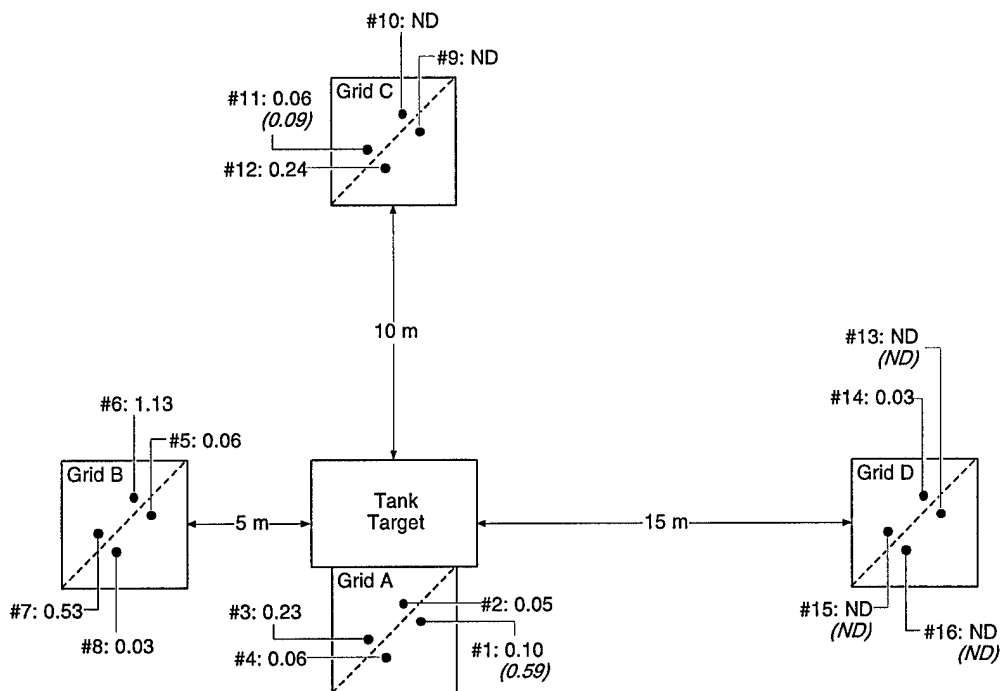

Figure 8. Areal distribution of explosives residues (mg/kg) in surface soils for sampling location 1-44 (duplicate samples italic and in parentheses).



c. TNT.

Figure 8 (cont'd).

found for various areas were related to the amount of munitions debris and the apparent length of time since the area was used.

Spatial heterogeneity

In this discussion, we consider spatial heterogeneity on four levels (long range, mid-range, short range, and very short range). These discussions will be based on concentration differences obtained using RP-HPLC Method 8330. The differences we will be discussing are true differences among subsamples analyzed, and are not caused by imprecision or inaccuracy from analytical determinations, i.e., analysis of the extracts. The analytical precision for Method 8330 in our laboratory has been documented many times and relative standard deviations (RSDs) range from 2 to 3% (Jenkins and Walsh 1987). An assessment across a number of different laboratories demonstrated that RSDs for Method 8330 were always less than 5% (Bauer et al. 1989, 1990). Triplicate determinations on the extract from sample 1-44-8 yielded an RSD of 1.9% for HMX determination. Accuracy was assessed using spiked samples and the results are presented in Table B6. For HMX, recoveries ranged from 88 to 116%, with a mean of 97%. Even better recoveries were obtained for RDX, where the mean was 101% with a range from 92 to 110%. Note that each of the nine recovery

estimates was obtained from different samples analyzed in different batches and at different times.

First to be assessed is the long-range spatial heterogeneity by comparing concentration differences among samples from different grids. The previous section described a large systematic effect of decreasing contaminant concentrations as distance from the targets increased (Table 2). This pattern, which is to be expected, has implications for any comprehensive sampling plan.

The mid-range spatial heterogeneity is assessed from differences among the four-point samples at a given depth from within a grid. Short-range variability is estimated from differences between pairs of samples that are separated by 1.0 m. For illustration, the HMX results for grid A, area 1-44, are used here to estimate mid- and short-range variability. These data appear typical for the site and they are convenient to use because all results exceed detection limits. The RSDs for the four samples at each of five depths range from 48.1 to 122%, with a pooled RSD of 83.5%.

This estimate for mid-scale heterogeneity includes the spatial effects of samples where pairs are 2.4 m apart and the two samples of a pair are 1.0 m apart (Fig. 8a). With RSDs near 100%, it seems that the HMX distribution is unlikely to be Gaussian (normal).

Short-range heterogeneity is estimated using the RSDs from the 10 pairs (two pairs at each depth) separated by 1.0 m. These RSDs range from 7.3 to 127%, with a pooled RSD of 71.8%. Although we expect RSDs to increase as concentrations decrease (Horowitz 1982), that pattern is not apparent for these samples. What is clear is that close-lying samples can produce widely disparate results, and our ability to estimate mean concentration for a grid using a single discrete sample is very poor. While the concentrations of RDX, TNT, 4-AmDNT, and 2-AmDNT are quite low relative to HMX at sampling location 1-44, the magnitude of the standard deviations are similar to their means, and hence our ability to estimate mean concentrations from a single discrete sample for these compounds is also very poor (Table 3).

In sampling area 1-48, there are an insufficient number of cases where measured values were above MDLs to obtain good estimates of standard deviations (Table 4). Even so, inspection of the data tells us that HMX and RDX concentrations for the four discrete samples at the same depth for a given grid are so disparate, that, here again, it would be impossible to obtain good estimates of mean concentrations from analysis of single discrete samples.

Finally, the very-short-range heterogeneity is examined using the 12 sets of duplicate samples from location 1-44, coupled with the results from

the sample size study. Here, we are looking at our ability to obtain replicate analytical-size subsamples from a carefully homogenized bulk sample. Each subsample goes through the entire extraction and HPLC analysis procedure. The RSDs for HMX for the 12 duplicates ranged from 1.6 to 99.7%, with a pooled RSD of 55.4%. In this case, RSDs do appear to vary with concentration, although the pattern is not completely consistent. For samples with concentrations above 10 mg/kg, the pooled RSD is 32%, compared to 74% for samples with concentrations below 10 mg/kg. Over all, these RSDs are considerably larger than those we have observed for similarly processed samples at other explosives sites, which ranged from 4.5 to 13.5% (Jenkins et al. 1996).

We conducted a sample size study to assess the reproducibility of analysis as a function of the size of subsample used. This study (Table 5) yielded some unexpected results. We expected to see measurable reduction in RSD estimates as sample size increased, but that trend was not present. The RSD estimates are much lower than those observed for the 12 duplicates discussed earlier; they are all in the 10–20% range, except for the 0.5-g sample size and one 2.0-g ground sample. The mean concentration estimates from different sample sizes showed excellent consistency, but they are considerably lower than the original estimates (Table 2). The initial HMX estimate for sample 1-44-8 was

Table 5. Analytical results for sample size/heterogeneity study using surface soils (0–15 cm).

Sample (rep.)	HMX concentration (mg/kg) by SW-846 Method 8330				
	20-g portion	7.5-g portion	2.0-g portion	2.0-g ground	0.5-g portion
1-44-8 a*	47.9	29.0	39.5	33.6	33.1
1-44-8 b	41.1	26.9	51.2	67.8	57.8
1-44-8 c	54.4	36.7	36.7	56.8	19.2
1-44-8 d	42.9	30.0	35.6	47.5	65.9
1-44-8 e	38.9	44.3	42.9	22.8	43.5
1-44-8 (X±%RSD)†	45.1 ± 13.7	33.4 ± 21.3	41.2 ± 15.2	45.7 ± 39.3	43.9 ± 42.7
1-44-11 a	168	171	132	113	73.5
1-44-11 b	128	120	133	145	99.3
1-44-11 c	143	155	135	118	65.2
1-44-11 d	129	133	169	138	274
1-44-11 e	136	139	129	124	105
1-44-11(X±%RSD)	141±11.5	143±13.9	140±11.7	128±10.4	124±69.5

* Letters indicate different replicate samples.

† Mean and percent relative standard deviation.

78.3 mg/kg (mean of duplicates), while the later sample size study gave a mean estimate of 41.8 mg/kg. A similar comparison for sample 1-44-11 yields 307 vs. 135 mg/kg.

Below, we suggest possible explanations for these inconsistencies. First, the RSDs from the sample size study might be expected to fall on the low side because the two samples used have mid-range concentrations where reproducibility should be optimal. Further, all the subsampling and analysis for this study were done over a short time, i.e., all five replicates were removed at one time. This invariably improves reproducibility, often greatly. With respect to decreases in concentration estimates, we acknowledge that there is a wide range in both the original values and the sample size study values. Referring to Table 5 and excluding the 0.5-g samples, we note that the other 20 analyses for sample 1-44-8 range from 113 to 171 mg/kg, compared with values of 204 and 409 mg/kg for the original analyses. The probability of both of the original analyses being substantially higher than any of the 20 later analyses is unlikely to be explained as a random occurrence. Furthermore, exactly the same pattern holds true for sample 1-44-11. In addition, data to be presented later in this report (see Table 9) show this same pattern for four additional samples. Consequently, we feel confident that a real concentration decrease has been demonstrated for the later analyses.

It was noted earlier that we observed a large amount of fine dust when these very dry bulk samples were homogenized and subsampled. Analysis of two samples of dust showed HMX concentrations two to three times higher than for the bulk soil (Table 6). Apparently, a substantial portion of the explosives residues are associated with very fine particles that are not bound to the bulk sands. Clearly, there is danger of loss of these fine particles during mixing and subsampling. Also, the surface layers of remaining bulk samples could be enriched as dust settles after mixing. Since HMX is known to be very stable under aerobic conditions (Grant et al. 1993), and particularly when soils are dry (Bauer et al. 1989), physical losses of dust may explain the much lower concentrations found in the sample size study. We could also speculate that analyte not lost as fine dust may be associated with the larger particles, and this could improve the reproducibility observed in the sample size study, since these samples had been previously manipulated.

Since any further site characterization at the inland firing ranges will require analysis of these

Table 6. Analysis of airborne dust from Fort Ord and CFB-Valcartier soils.

Sample	HMX concentration (mg/kg) by SW-846 Method 8330	
	Soil	Dust
Fort Ord (1-44-composite grid A 0-15 cm)	262	860
CFB-Valcartier (surface composite)	382	739

types of soils, it is important to further investigate these issues and develop an improved homogenization and subsampling procedure. Possibly, a misting device could be used to increase the soil moisture level prior to subsampling, thereby reducing dust losses. Separate aliquots could be used for moisture determination, thereby allowing correction of concentration estimates to a dry weight basis. In a later section of this report, we will provide further evidence that the problem of poor reproducibility resides in sample processing rather than extract analysis.

Evaluation of various on-site methods for use with soils from the inland ranges

If additional site characterization at Fort Ord is needed, the use of on-site methods and compositing could substantially reduce costs and time (Crockett et al. 1996). The two explosives compounds of most significance at the Fort Ord inland ranges are HMX and RDX. Two on-site methods have been developed for RDX. The first is an enzyme immunoassay method by Strategic Diagnostics, called the DTECH method. The second is a colorimetric method by Jenkins and Walsh (1992), which is commercially available from EnSys Corporation (now Strategic Diagnostics).

To compare the utility of these two methods, two experiments were run. In the first experiment, the extraction kinetics were evaluated. Three depth increments (0-15, 30-45, and 105-120 cm) of sample 1-44-1 were selected for this evaluation. Each sample was extracted with acetone for 3, 10, and 30 minutes, and an aliquot of the resulting extract was analyzed for HMX using RP-HPLC. The results show that extracts collected after only a 3-minute extraction period provide concentrations of HMX that are greater than 97% of those obtained after 30 minutes (Table 7). These results agree with assessments made during initial devel-

Table 7. HMX concentrations (mg/kg) from extraction time study using acetone.

Sample	HMX (mg/kg) by RP-HPLC extraction time		
	3-minutes	10-minutes	30-minutes
1-44-1 (0-15 cm)	260	262	266
1-44-1 (30-45 cm)	<1	<1	<1
1-44-1 (105-120 cm)	2.7	2.6	2.7

opment of this method (Jenkins and Walsh 1992). The fast extraction kinetics with acetone for soils from the inland ranges will make the use of on-site methods for site characterization very convenient, and analytical turn-around times will be short.

In a second experiment, a set of 11 soil samples was selected on the basis of results from analysis by SW846 Method 8330. We selected these samples to encompass a range of HMX concentrations. A 20-g portion of each soil was extracted with acetone by manually shaking periodically over 30 minutes. Aliquots of each acetone extract were analyzed by three methods: 1) HPLC using the confirmation separation of Method 8330, 2) DTECH's on-site enzyme immunoassay method, and 3) the on-site colorimetric method. Because our research at CFB-Valcartier demonstrated that the colorimetric method would respond to both HMX and RDX (Jenkins et al. 1997a), and because

the concentrations of HMX predominated in these soils, the colorimetric method was calibrated with a solution containing a known concentration of HMX.

Results of these analyses are presented in Table 8. Concentrations of HMX and RDX in these extracts, obtained by RP-HPLC analysis, ranged from 17 to 293 mg/kg, and from ND (not detectable) to 1.1 mg/kg, respectively, on a soil dry weight basis. An inspection of the results from the colorimetric on-site method indicates that they are quite similar to those for HMX from RP-HPLC. The DTECH results, on the other hand, do not seem to correlate with either the HMX or the RDX results, giving a value that is intermediate between the two.

We examined HMX concentrations from RP-HPLC and those from the on-site colorimetric method using correlation analysis. Note that this comparison is made on aliquots of the same extract, i.e., the variability attributable to subsampling the soil is removed. When a linear model with intercept was fitted, a slope of 0.945 and intercept of -4.57 were obtained with a correlation coefficient of 0.984 (Fig. 9). This result is quite similar to that found at CFB-Valcartier, which had a slope for this relationship of 1.004, with a correlation coefficient of 0.992. These results demonstrate that the colorimetric method could be used to estimate HMX concentrations for soils at the Fort Ord impact ranges with a confidence approximately equivalent to that from RP-HPLC analysis.

Table 8. Assessment of on-site methods for RDX and HMX in Fort Ord soil samples.

Location	Depth (cm)	Concentration (mg/kg)			
		HPLC		Colorimetric	D TECH
		RDX	HMX		
1-44-1	0-15	0.2	210	200	>6
1-44-2	0-15	0.1	253	268	>6
1-44-3	0-15	0.9	282	258	>6
1-44-5	0-15	ND*	197	176	>6
1-44-6	0-15	1.0	235	234	46-60
1-44-6	15-30	ND	18	30	>6
1-44-7	0-15	0.3	293	244	>6
1-44-8	0-15	ND	68	47	2.5-5.0
1-44-8	15-30	ND	17	8	1.5-2.5
1-44-11	0-15	ND	162	141	4.6-6.0
1-44-12	0-15	1.1	110	87	4.6-6.0

*Not detectable.

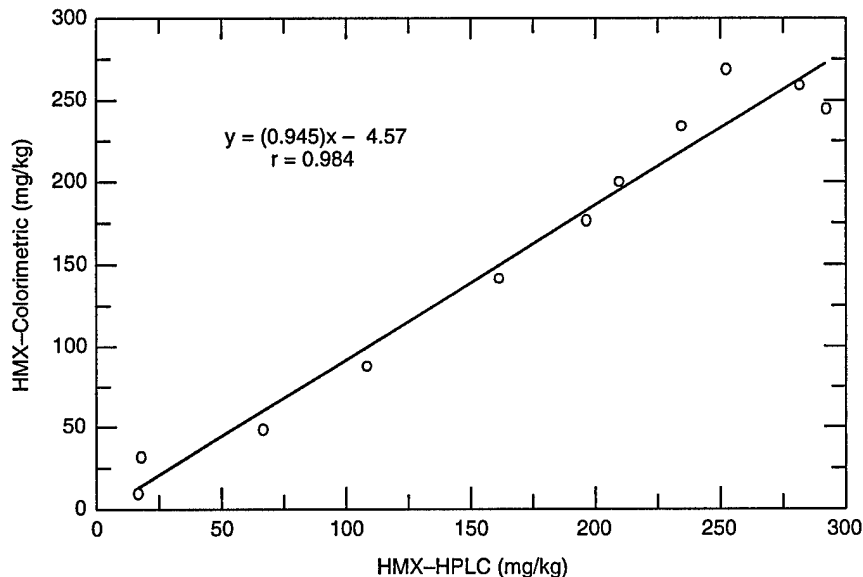

Figure 9. Correlation of HMX concentration estimates from the colorimetric on-site method with those from RP-HPLC analysis of the same acetone extracts.

Correlation analysis between the original HMX estimates using RP-HPLC and the HPLC analyses for the acetone extracts of these 11 samples yielded an r of only 0.795, with slope of 1.44 and an intercept of 3.27. For 10 of the 11 pairs, the original analysis was higher than the later analysis. The mediocre agreement of these results, compared to the excellent agreement of the colorimetric versus HPLC analyses on the same extract, could be explained in two ways: 1) the difference is ascribable to soil subsampling, or 2) the difference is attributable to the different extraction methods used. Results obtained at CFB-Valcartier, where a large number of samples similar to these from Fort Ord were analyzed for HMX using these two extraction methods, yielded a slope of 0.99 and a correlation coefficient of 0.97. This result, coupled with the extraction time study presented here (Table 7), and the original development work on this on-site method (Jenkins and Walsh 1992), all indicate that the two different extraction methods yield equivalent results, particularly for sandy soils. This reinforces our conclusion that the reliability problem is with soil subsampling rather than extraction or analysis of the extracts.

The results from the DTECH method appear to provide little or no utility for this application. While the method is generally quite specific for RDX in many applications, it has a significant cross-reactivity to HMX, which may not have been

fully characterized. According to the DTECH kit, an HMX concentration of 15 mg/kg would respond as an RDX concentration of about 1 mg/kg. This cross-reactivity is reported at the detection limit and the level of cross-reactivity at higher concentrations was not provided. In any case, the presence of HMX appears to interfere to such a degree as to make the DTECH test unusable at Fort Ord.

Unfortunately, neither of these on-site methods will provide reliable estimates for RDX. Another option would be to use RP-HPLC as an on-site method. Racine et al. (1992) used on-site HPLC for site characterization of explosives residues at an impact area on Fort Richardson, Alaska. The advantage of this approach is our ability to obtain HMX, RDX, and TNT estimates from a single analysis. The disadvantage is the requirement of having to find a location to set up an HPLC instrument and the need for a more highly trained chemist on site to provide this type of analytical support.

Composite preparation

Clearly, the results above demonstrate that the use of single discrete samples to represent grids of even modest size at the inland ranges at Fort Ord will result in enormous uncertainty in concentration estimates for these explosives analytes. Another approach is to collect a number of dis-

crete samples to represent a grid, and either analyze each separately, or produce a composite sample. The composite sample is a physical average of the discrete samples and it can be analyzed instead, with replication when needed. Analysis of a large number of discrete samples is quite attractive scientifically, but it is impractically expensive using currently available methods. The use of composites is attractive from a financial point of view, but it must be shown that composites can be prepared using simple, fieldable procedures, and that the resulting composites are representative of the discrete samples from which they were prepared.

Research conducted at a number of explosives-contaminated sites has demonstrated that a simple method quite successfully produces composites that are in good agreement with the mean values of the discrete samples making them up (Jenkins et al. 1996, 1997a). To ensure that this is also true for the soils at the inland ranges at Fort Ord, an experiment was conducted using the discrete samples from area 1-44. Composites were prepared for three depth intervals from the four grids in this sampling area. The results from extraction and colorimetric analysis of these composites are presented in Table 9. In all cases, the results for HMX in these composite samples are within the range produced by the mean plus or minus a standard deviation for the discrete

samples using data from Method 8330. In addition, the HMX results for the four composites from the 0- to 15-cm depth are also in good agreement with the mean of the discrete samples analyzed using the on-site colorimetric method. Development of improved procedures for dealing with dust losses will likely further improve the agreement.

Overall, the results from this experiment verify our earlier conclusions (Jenkins et al. 1996, 1997a) that it is feasible and inexpensive to produce composite samples on-site using simple procedures, and that the resulting composites are a good way to estimate mean explosives concentrations within grid-sized areas. When the objective is to obtain an unbiased estimate of the mean concentration within a grid, it may be appropriate to collect samples randomly, in so far as that is possible in the presence of UXO.

SUMMARY AND CONCLUSIONS

A set of 280 soils samples was collected from depths ranging from 0–15 cm to 105–120 cm at inland firing ranges 44 and 48 at Fort Ord in August 1997. Analysis of these samples showed that HMX was the explosives residue that was present in highest concentration at these ranges. Concentrations as high as 587 mg/kg were measured in sur-

Table 9. Results for assessment of composite preparation method.

Sample	HMX concentration (mg/kg)		
	Discrete sample mean from Method 8330	Discrete sample mean using on-site method	Composite sample using on-site method
1-44-(1-4) (0–15 cm)	295 ± 142	231	262
1-44-(1-4) (30–45 cm)	0.6 ± 0.3		0.4
1-44-(1-4) (105–120 cm)	2.5 ± 3.1		2.6
1-44-(5-8) (0–15 cm)	320 ± 246	198	186
1-44-(5-8) (30–45 cm)	0.6 ± 0.2		0.5
1-44-(5-8) (105–120 cm)	3.1 ± 3.3		0.7
1-44-(9-12) (0–15 cm)	109 ± 133	66.2	95.8
1-44-(9-12) (30–45 cm)	0.7 ± 1.2		0.5
1-44-(9-12) (105–120 cm)	0.5 ± 0.6		0.4
1-44-(13-16) (0–15 cm)	1.4 ± 1.9	0.7	ND
1-44-(13-16) (30–45 cm)	ND*		ND
1-44-(13-16) (100–120 cm)	ND		NA†

*Not detectable.

†Not available.

face soils (0–15 cm) in a heavily blasted area in range 44. An enormous amount of debris from use of LAW rockets was found at this location, and it is the LAW rocket that is the source of these HMX residues. This is attributable, at least in part, to the high percentage of these rockets that do not detonate on impact, sometimes spilling the explosives on the soil surface.* It is not possible to assess whether HMX concentrations have declined substantially in these soils since the 1994 study, because there were so few samples analyzed at this location, and the exact locations of the sampling points are not known. Concentrations of HMX in subsurface soils were much lower than in the surface, but in a few locations, concentrations above 10 mg/kg were measured in soil at the 15- to 30-cm depth. In fact, at several sampling locations in the grid next to the target, concentrations above 5 mg/kg were observed in soil from the 105- to 120-cm depth. It is uncertain whether the HMX at this depth had leached in aqueous solution in downward percolating water, or had migrated through this coarse-grained soil as very fine particles. It is possible that the soils had been physically disturbed to this depth by the tremendous number of large explosions that took place over many years. It is also possible that, in the process of obtaining these deep samples, they were contaminated by surface soils with a high HMX concentration.

Concentrations of RDX in the inland ranges are barely detectable in most locations. The detectable levels are largely confined to the surface 0–15 cm at range 44. Concentrations only exceeded the 0.5-mg/kg action level at the most heavily impacted area in range 44, and there only in the grid located within 5 m of the target. Concentrations of RDX have clearly declined in these surface soils since the 1994 study. Natural attenuation of RDX in the surface soils will undoubtedly continue, and, even if no remedial actions are taken, RDX will be undetectable in surface soils within several years. Our experience tells us that RDX neither biodegrades nor degrades chemically under aerobic conditions (Grant et al. 1995). Thus, it is likely that the RDX has migrated with downward percolating water to deep into the soil profile. Once dissolved in water, RDX is known to migrate rapidly in soils.

Like RDX, the analytes TNT, 4-AmdNT, and 2-

AmdNT were detected in soils at the inland ranges, but measurable concentrations were always low and confined to the surface soils. In most instances, the concentrations of the two amino transformation products exceeded that of TNT. Since these three compounds are more sorptive to soils than is RDX, these low concentrations will persist in the surface soils longer than RDX, even though soils at the inland ranges are largely coarse sands and have little retentive capacity.

The largest problem for site characterization at the inland ranges is the extreme heterogeneity in spatial concentration that is present at all distance scales. To demonstrate just how severe this problem can be, a log-normal distribution was constructed, based on the HMX data from the four discrete samples collected from grid A, sampling location 1-44 (Fig. 10). This figure clearly shows that the concentration of HMX in discrete samples from this area can vary dramatically from sample to sample. Providing a good estimate of the mean HMX concentration for this area would require the analysis of a large number of discrete samples. While this problem has been identified at other explosives-contaminated sites (Jenkins et al. 1996, 1997a), the heterogeneity observed at the inland ranges is the most extreme observed thus far.

Before performing any more analyses at the inland ranges, our first priority must be to develop improved sampling and sample processing procedures. Our results reveal that one reason for the poor precision and accuracy is the variable losses of fine dust that is highly enriched in HMX. Possible cures, such as slight elevation of soil moisture using a small garden sprayer or other misting device during sampling and sample processing, should be investigated with existing samples. Whatever method ultimately evolves, it must be adaptable to field use, starting with the removal of soil samples from the ground. The technique of mixing in place before a sample is removed (used in this study) may have resulted in some loss of fines. Either this practice should be omitted or soils should be moistened while mixing takes place. The need for extensive mixing may be lessened, though, since we will recommend the use of composite samples containing soil taken from four or more points.

Since much of the site is free of significant explosives residue, it is inappropriate to estimate a mean concentration for a large area. Instead, sampling should concentrate on surface soils around target locations, to define the boundaries of contamination. To demonstrate this point, the concen-

*Personal communication with S. Thiboutot, Canadian Defence Research Establishment Valcartier, Courcellette, Quebec, 1998.

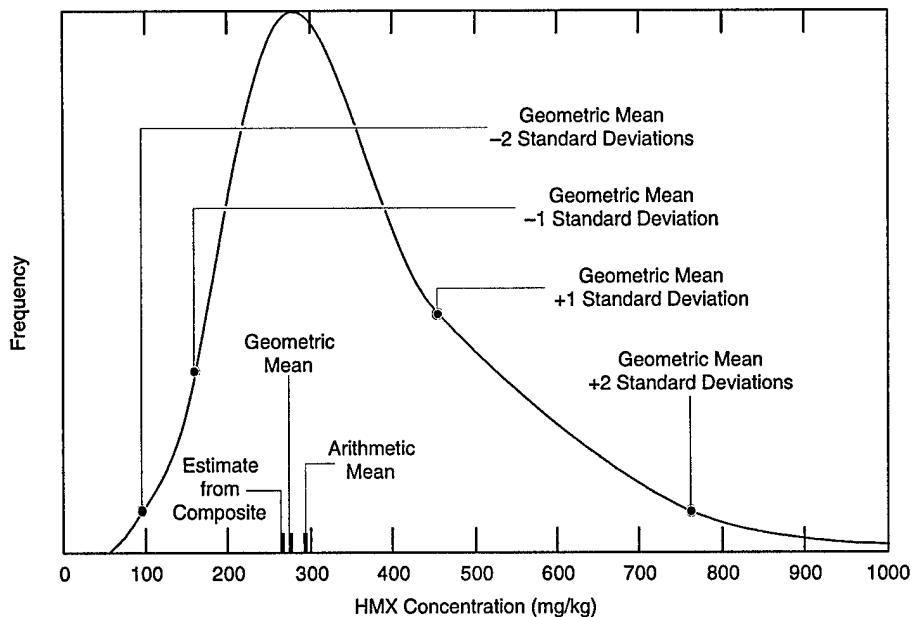

Figure 10. Log-normal distribution of HMX for discrete soil samples from grid A, sampling location 1-44.

trations of HMX in surface soils as a function of distance from the target are plotted for sampling location 1-44, along with similar data from CFB-Valcartier (Fig. 11). With concentrations decreasing as distance from the target increases, a logical sampling array would use concentric rings with the target at the center. Such rings might employ radii varying by 3 to 5 m. Eight or more sample points would be located equidistant from each other around each ring, which would allow two composite surface samples to be formed for each ring (Fig. 12). Each discrete sample should contain about a kilogram (± 200 g) of soil and be homogenized thoroughly prior to subsampling for formation of composites, as described earlier in the *Experimental Methods* section. Each composite would contain one-half of the sampling points chosen in an alternating pattern. Results of this work demonstrate that EOD personnel can efficiently collect soil samples for site characterization at the same time that they are clearing the site for unexploded ordnance. Since the major portion of the explosives residues at the inland ranges are in the surface soils, samples for additional characterization should be relatively easy to collect. The depth of contamination in specific areas can be determined iteratively after the extent of surface contamination is mapped.

The choice of four discrete samples per composite is a compromise between 1) our desire to improve the reliability of each analysis (represent-

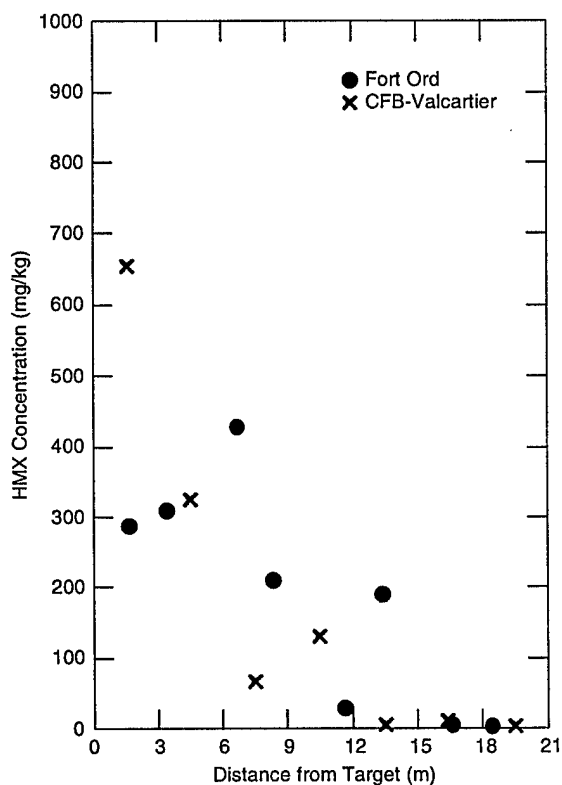

Figure 11. Concentration of HMX in surface soils at Fort Ord sampling location 1-44 and CFB-Valcartier as a function of distance from targets.

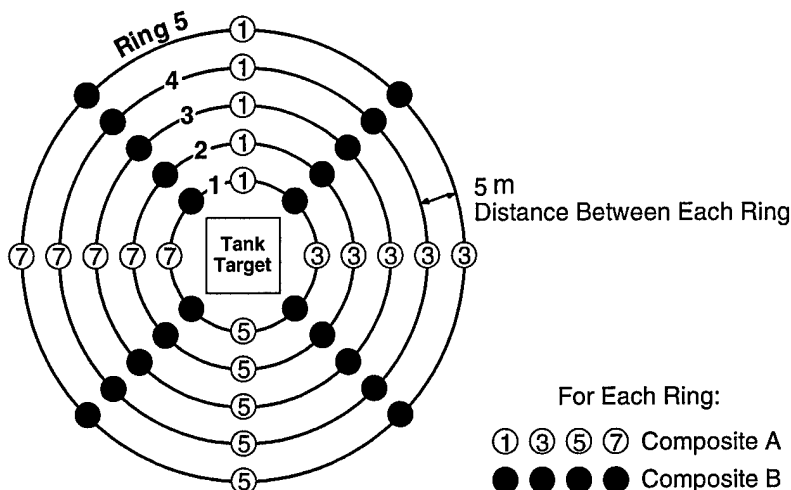

Figure 12. Proposed concentric ring sampling plan for target areas.

tativeness of each sample) by “averaging out” spatial heterogeneity effects, and 2) our need to minimize the loss of detection capability for hot spots because of the dilution effects of compositing. While the detection limits for composites compared to discrete samples are theoretically reduced by $1/k$, where k is the number of discrete samples combined in a composite, such detection capability could only be lost when one discrete sample is contaminated and all others in the composite are barren. Given the method of contamination at a firing range, i.e., multiple explosions in a small area, and the relative closeness of discrete samples to be composited, we cannot envision the existence of this extreme condition. None of the data we have collected for discrete samples in this study and elsewhere (Jenkins et al. 1996, 1997a) even remotely approximate this condition. In fact, if the distribution was actually this extreme, an entirely different approach designed for locating hot spots would be required (Gilbert 1987).

The two most widely used on-site methods for RDX were evaluated with selected soil samples from the inland ranges. Results obtained with the DTECH immunoassay method demonstrate that it will not provide useful results at this site for RDX because of the level of interference caused by the presence of HMX at concentrations several orders of magnitude above RDX. The response to HMX is not sufficient to determine HMX either. Therefore, the DTECH RDX method is of no use in characterizing the inland ranges at Fort Ord.

The colorimetric-based EnSys method was also evaluated. It is a simple, reliable on-site method for determining HMX concentrations when HMX

concentrations exceed RDX by at least an order of magnitude. This was the case in all areas where the concentrations of HMX exceeded 2 mg/kg. The EnSys method was not useful for estimating RDX concentrations at the inland ranges because of its response to HMX. If RDX and HMX are present in similar concentrations, this method will respond to both and provide an estimate that is more heavily weighted by RDX, which has a response factor that is about twice that of HMX.

For example, if RDX and HMX are both present at 1 mg/kg and the method is calibrated with solutions containing RDX, the determined concentration would be 1.5 mg/kg RDX. If, on the other hand, the method was calibrated using solutions containing HMX, the determined concentration would be 3 mg/kg HMX. Thus, if this method is selected, it is important to specify the calibration method required. For characterization of the inland ranges, we recommend calibrating with HMX. An MDL for HMX has been estimated at 1.6 mg/kg (Jenkins et al. 1995), but it can be lowered to about 0.4 mg/kg, if necessary, by changing the soil-to-solvent ratio from 20 g/100 mL to 40 g/50 mL.

If it is necessary to also provide on-site analysis for TNT in soils from the inland ranges, the colorimetric-based TNT test can be run with the same acetone extract used for the HMX test. This test was not evaluated with soils from the inland ranges, but data from CFB-Valcartier indicate that it is quite acceptable for this application. The TNT test conducted with a soil-to-solvent ratio of 40 g/50 mL should provide an MDL of about 0.3 mg/kg. A kinetic study conducted here indicated

that a 3-minute extraction time was adequate for the sandy soils present at the inland ranges. This study was conducted with the standard 20-g/100-mL soil-to-solvent ratio and should be tested with the 40-g/50-mL ratio if that is selected. Our experience says that a 3-minute extraction time will be adequate.

No currently available on-site method will provide reliable estimates for RDX in soils from the inland ranges at Fort Ord (Crockett et al. 1996). Use of HPLC, the method of choice for laboratory analysis of explosives, in a mobile laboratory or in an expedient laboratory set up at Fort Ord, would provide estimates for RDX as well as HMX, TNT, 2-AmDNT, and 4-AmDNT. If HPLC is selected, either for on-site or off-site use, we recommend the LC-CN column for obtaining quantitative results. This method can use the same acetone extracts of the on-site methods, but they must be diluted 1:4 with water prior to injection. Usually, an LC-18 column is used for quantitation and the LC-CN column is used for confirmation only in Method 8330, but for the five analytes present at the inland ranges, the LC-CN provides better resolution and more reliable quantitation.

Given the demonstrated reliability and fast turnaround time of the on-site colorimetric method for HMX, duplicate analyses should be conducted using this method on each composite after they are formed for the first rings. Sampling and analysis would continue for increasingly distant rings until two successive rings yield results having all four composite analyses below the action level. If desired, an upper 95 or 99% confidence limit could be calculated for the mean of the four results. When the upper confidence limit is still above the action level, a further ring could be sampled and a new upper confidence limit calculated using the six results. While the distribution of results from discrete sample analysis at the inland ranges tends to be log-normal, we do not expect that the distribution of composites from within a ring will deviate greatly from a normal distribution. Consequently, we believe it would be appropriate to use normal distribution statistics in this regard. If the data indicate otherwise, log-normal distributions could be used.

We tried to follow a draft protocol (App. A) for conducting preliminary site assessments wherein we optimized the information available from relatively few measurements. This plan worked quite well, although it was not possible to follow every aspect of the protocol. For example, the depth study should be done with composite samples

from different depths rather than from discrete samples. Thus, we conducted more analyses than were envisioned in the original plan. Nonetheless, depth profile data were acquired. The compositing procedure was validated using the data in Table 9. A reference method of analysis (EPA Method 8330) was compared with an on-site colorimetric method and RP-HPLC analysis of the extracts used for the colorimetric analysis. The geometric layout of grids and the sample positions within each grid allowed us to evaluate spatial heterogeneity over various distances as intended in the draft protocol.

To determine an action level for the inland ranges, it is necessary to specify the depth interval over which the action level applies. This is particularly important for impact ranges that have a significant concentration gradient with depth, such as we have demonstrated both at the inland ranges at Fort Ord and at CFB-Valcartier. Our surface samples were vertical composites from 0–15 cm, and this interval may be a reasonable choice for an environmental risk-based criterion.

LITERATURE CITED

- Bauer, C.F., T.F. Jenkins, S.M. Koza, P.W. Schumacher, P.H. Miyares, and M.E. Walsh** (1989) Development of an analytical method for the determination of explosives residues in soil: Part III. Collaborative test results and final performance evaluation. USA Cold Regions Research and Engineering Laboratory, Special Report 89-9.
- Bauer, C.F., S.M. Koza, and T.F. Jenkins** (1990) Liquid chromatographic method for determination of explosives residues in soil: Collaborative study. *Journal of the Association of Official Analytical Chemists*, 73: 541–552.
- Crockett, A.B., H.D. Craig, T.F. Jenkins, and W.E. Sisk** (1996) Field sampling and selecting on-site analytical methods for explosives in soil. EPA Federal Facilities Forum Issue Report 540/R-97/501.
- EPA** (1994) Nitroaromatics and nitramines by HPLC. Second Update SW846 Method 8330, September, 1994.
- EPA** (1996) Drinking water regulations and health advisories. U.S. Environmental Protection Agency Office of Water Report EPA 822-B-96-002.
- Gilbert, R.O.** (1987) *Statistical Methods for Environmental Pollution Monitoring*. New York: Van Nostrand Reinhold.
- Gore, S.D., and G.P. Patil** (1994) Identifying extremely large values using composite sample

- data. *Environmental and Ecological Statistics*, **1**: 227-245.
- Grant, C.L., T.F. Jenkins, and S.M. Golden** (1993) Experimental assessment of analytical holding times for nitroaromatic and nitramine explosives in soil. USA Cold Regions Research and Engineering Laboratory, Special Report 93-11.
- Grant, C.L., T.F. Jenkins, K.F. Myers, and E.F. McCormick** (1995) Comparison of fortification vs. field contamination for holding time estimates of soils containing explosives residues. *Journal of Environmental Toxicology and Chemistry*, **14**: 1865-1874.
- Horowitz, W.** (1982) Evaluation of analytical methods used for regulation of food and drugs. *Analytical Chemistry*, **54**: 67A-76A.
- Jenkins, T.F., and M.E. Walsh** (1987) Development of an analytical method for explosives residues in soil. USA Cold Regions Research and Engineering Laboratory, Special Report 87-7.
- Jenkins, T.F., and M.E. Walsh** (1992) Development of field screening methods for TNT, 2, 4-DNT, and RDX in soil. *Talanta*, **39**: 419-428.
- Jenkins, T.F., M.E. Walsh, P.W. Schumacher, and P.G. Thorne** (1995) Development of colorimetric field screening methods for munitions compounds in soil. In *Proceedings of Environmental Monitoring and Hazardous Waste Site Remediation Symposium*, 19-21 June, Munich, Germany.
- Jenkins, T.F., C.L. Grant, G.S. Brar, P.G. Thorne, T.A. Ranney, and P.W. Schumacher** (1996) Assessment of sampling error associated with collection and analysis of soil samples at explosives contaminated sites. USA Cold Regions Research and Engineering Laboratory, Special Report 96-15.
- Jenkins, T.F., M.E. Walsh, P.G. Thorne, S. Thiboutot, G. Ampleman, T.A. Ranney, and C.L. Grant** (1997a) Assessment of sampling error associated with the collection and analysis of soil samples at a firing range contaminated with HMX. USA Cold Regions Research and Engineering Laboratory, Special Report 97-22.
- Jenkins, T.F., C.L. Grant, G.S. Brar, P.G. Thorne, P.W. Schumacher, and T.A. Ranney** (1997b) Assessment of sampling error associated with the collection and analysis of soil samples at explosives contaminated sites. *Field Analytical Chemistry and Technology*, **1**: 151-163.
- Parker, L.V., A.D. Hewitt, and T.F. Jenkins** (1990) Influence of casing materials on trace chemicals in well water. *Ground Water Monitoring Review*, **10**: 146-156 (Spring).
- Racine, C.H., M.E. Walsh, C.M. Collins, D.J. Calkins, B.D. Roebuck, and L. Reitsma** (1992) Waterfowl mortality in Eagle River Flats, Alaska: The role of munitions residues. USA Cold Regions Research and Engineering Laboratory, CRREL Report 92-5.
- Steinberg, S.M., J.J. Pignatello, and B.L. Sawhney** (1987) Persistence of 1,2-dibromoethane in soils: Entrapment in interparticle micropores. *Environmental Science and Technology*, **21**: 1201-1208.

APPENDIX A: GUIDE FOR PRELIMINARY TESTING OF MUNITIONS-CONTAMINATED SITES—PREPARATION FOR SAMPLING PLAN

Introduction

No single approach to site characterization will be appropriate for all places contaminated by munitions. This guide for preliminary testing is intended for sites where widely dispersed contamination is thought or known to be present. In contrast, a modified approach would probably be appropriate for a site having highly localized "hot spots," although a recent report suggests that both objectives can sometimes be attained with a single plan (Gore and Patil 1994). It is quite likely that some elements of this proposed guide will be unsuitable at some sites, while other sites may require elements not included here. For this reason, an experienced team should conduct these tests and interpret the results, and consider any other pertinent input, such as budget information. Recommendations for a full-scale sampling plan will follow. A "cookbook" approach to this problem will never be adequate. However, a plan recommendation must be practical and within the scope of what can be expected of commercial samplers.

The bulk of explosives contamination generally resides in near-surface soils, the most commonly encountered explosives being solids at environmental temperatures. They were most often released as particulates, which tends to exacerbate the sampling problem owing to heterogeneity of distribution. These particles have low solubility and, from a kinetics point of view, dissolve very slowly in aqueous solution. Of course, some dissolution does occur and, at manufacturing sites, a portion of the contaminants enters the soil in aqueous solution. In any case, there is abundant evidence that high concentrations of these compounds and their biodegradation products can persist in near-surface soils for decades (Steinberg et al. 1987, Grant et al. 1995). Although this document emphasizes shallow contamination, it is clear that in some cases contamination can be found at considerable depth.

The purpose of this protocol is to efficiently and economically obtain results essential for developing an optimal, full-scale sampling plan. Our recent studies have demonstrated the efficacy of homogenizing samples and making composites on site, followed by rapid on-site analysis (Jenkins et al. 1997b). This approach offers the major advantages of samples being representative and results being timely, thereby lending itself to iterative followup during the same sampling event. These guidelines assume the use of this technology in both the preliminary and full-scale studies.

Preliminary study plan

1. *Dividing a site into potential remediation units*

Sufficient historical information on the contaminants present must be known. Otherwise, a few laboratory analyses will be required before proceeding. Many installations have several potentially contaminated sites, such as a disposal lagoon, a burning ground, an impact area, or a load line. Each of these sites can be subdivided into potential remediation units that are more internally homogeneous than the site as a whole. Typical reasons for subdividing a site into units are:

- Differing exposure histories with respect to time, munitions composition, method of contamination, and level of contamination.

- Differing soil conditions such as texture, moisture, slope, and vegetation.
- Prior surveys or any prior remedial treatments, or both.
- Practical constraints, such as size.

Therefore, a site should be logically divided into units where each is sufficiently uniform to suggest a single remediation approach and to justify characterization by a mean concentration of contaminants present. At any given site, remediation units may vary widely in size but, for illustration in this document, we will describe a unit that is 50 × 100 m (see Fig. 6, main text). Clearly, the division of a site into units is a judgment and revisions may be needed as preliminary data become available.

2. Sampling locations

When at least four potentially contaminated sections (potential remediation units) are present, four sample cores (0–46 cm [0–18 in.]) should be taken from each (for a total of 16). If there are fewer than four units, the number of cores should be proportionately increased. With more than six units, the number of cores can possibly be decreased when there is great similarity among the units. However, this may be impractical if units have widely different characteristics.

Cores are taken in pairs, 1 m apart, with each unit having two pairs. These pairs are located at one-quarter and three-quarters of the distance along a diagonal through the unit (BD in Fig. 6). This is a good arrangement if results show extreme disparity between the means of the pairs. Then two additional sample pairs can be taken later on the other diagonal (AC in Fig. 6). This forms a 2ⁿ factorial pattern. Cores of 5.6-cm diameter, or other appropriate size, are taken to a depth of 46 cm and divided into 0- to 15-, 15- to 31-, and 31- to 46-cm segments. Individual segments are placed in separate containers, such as Zip-Loc™ bags, and carefully homogenized by hand. Depending on the results from these initial samples, deeper soil cores may or may not be necessary.

3. Compositing

Before subsampling, a discrete sample is placed in an aluminum pie plate, or other suitable container, where rocks, roots, and other debris are removed. After further stirring and mixing, and coning and quartering (or equivalent), remove a 40-g portion. The four discrete samples for a given depth and unit are combined and thoroughly homogenized to form one composite for each depth in each unit (a minimum of 12 composites). Note that this assumes the action level of concentration being at least four times higher than the quantitation limit of the analysis method. Any failure to meet this criterion will require using fewer discrete samples in each composite if we wish to retain the capability for detecting “hot spots” for surgical excavation.

4. Subsampling for analysis

On-site analytical methods require the extraction of 20-g subsamples. To obtain these subsamples, transfer each bulk sample (discrete or composite) to a pie plate and mix again before subsampling. A good way to do this is to cone and quarter and then use a scoop to remove approximately 5 g of soil from each quarter.

5. Determining extraction time

Since the minimum adequate extraction time will vary for different sites, this is the first parameter to be determined. One subsample from each depth of the unit with the heaviest soil or highest organic content is extracted for 3, 10, and 30 minutes and the extracts are analyzed by on-site methods. Select the shortest time to produce adequate extraction of the heaviest soil for all further analyses. If different soil types are present on the site, either horizontally or vertically, and only a few soils require long extraction times, the samples might be split into two groups, but this does complicate the logistics.

6. Determining depth of contamination

One subsample from each composite is analyzed by the on-site methods. The results of these analyses will tell us how deeply each unit is contaminated by the various explosives analytes. If analyte concentrations in the 0- to 15-cm portion of the cores are much higher than at the lower depths, as is often the case, these surface samples may be suitable for characterizing the horizontal extent of contamination within units. Use of surface samples is always best, when appropriate, since it is the easiest and most economical way to obtain representative samples by combining several aliquots of soil from within a defined area. We call such samples "area integrated." If there is no consistent difference in the three depths, or if concentrations in the composites from the 15- to 31-cm depth are as high as or higher than in the surface 15 cm, it will be necessary to collect deeper samples to document the depth of contamination. Deeper samples make composite sampling more time-consuming and expensive than when surface samples are used.

7. Validating on-site analyses

Aliquots of one extract from each section (or more if desired) are used for comprehensive laboratory analyses. When there are no local laboratories and the extract cannot be transported, it will be necessary to do the laboratory analyses on separate soil subsamples, obtained as described in section 4. In any case, prior arrangements should be made to ensure that these results are quickly generated as they are required to identify interferences and misidentifications that would invalidate on-site results.

A spike recovery study should also be done for each analyte of interest on at least one extract from each unit using the on-site methods. Although a single spike concentration is acceptable, a better procedure would be one spike addition and one matrix dilution (assuming the concentration is at least twice the quantitation limit) to more fully characterize the linearity of analyte response.

8. Validating compositing procedure

Subsamples (20 g) from all discrete samples at one selected depth are analyzed by on-site methods. When it appears that the 0- to 5-cm samples will be used for characterization, they should be used here. This would be a minimum of 16 samples when there are four or fewer units. Means of the concentrations for the four discrete samples used to make up a composite can be compared to the composite concentration determined earlier. Relative differences will tend to be greater for concentrations close to the lower quantitation limit. In general, agreement should

be within a factor of 1.5 and differences greater than a factor of 2 should prompt further inquiry into the method used to prepare the composites.

9. Short- and long-range spatial heterogeneity

The results required in section 8 provide at least eight pairs of samples separated by 1 m. This will yield eight estimates of the relative standard deviation (RSD) associated with short-range heterogeneity. When these estimates are all less than 100%, which would represent reasonably good homogeneity for munitions residues, they can be pooled to give an overall RSD. It would not be unusual for pairs of core samples to have RSD values greater than 100% because they represent such small volumes (Jenkins et al. 1997b). If one unit or one pair within a unit gives an RSD estimate that is much larger than the others, and the concentrations are moderate or high, reanalysis of new subsamples may be appropriate. When reanalysis confirms an atypical result, that area may require more intensive sampling than the other sections. However, when concentrations are low relative to quantitation levels, larger RSDs are common and reanalysis is probably not necessary. Furthermore, when "area integrated" samples are employed, the heterogeneity will be greatly reduced, usually by a factor of 10 or more, depending on how many aliquots are included.

This same set of analyses also yields information on long-range spatial heterogeneity. The means of pairs within a unit can be compared and the unit means should also be compared. Such results might lead to changes in unit assignment or they may call for further preliminary samples as noted in section 2 above.

Concluding remarks

The array of results described above can be used to help plan grid layouts and compositing strategies for a comprehensive sampling plan. Although we can not assume a one-to-one correspondence of RSDs from core samples to larger surface samples, the preliminary results are essential for choosing sampling depths and extraction times, and for validating on-site compositing and analysis procedures. Obviously, this preliminary plan is not a trivial exercise but, measured against the cost of conducting a poorly designed full-scale sampling plan with costly off-site analysis, we believe the expense is entirely justified and represents a cost-effective approach. Such preliminary data should result in a full-scale plan that requires the fewest possible analyses to produce reliable results. Further, the savings in analysis costs and the timeliness of having results available offer tremendous advantages.

Specific guidance for compositing can only be given after data quality objectives are specified for a site. For example, if concentration distribution within a unit is required, compositing would be done within grids. These data might be used to change remediation unit boundaries. It would also be feasible to study units sequentially because of the fast turnaround with on-site analysis. In contrast, verification of the effectiveness of remediation might dictate that only a mean and upper confidence limit is needed for each unit.

Consider the example cited earlier of a 50- × 100-m remediation unit. Suppose the preliminary study indicated the use of surface (0- to 5-cm) samples. The RSD estimates for core samples separated by 1 m averaged 80%. If we use area integrated composite samples containing 16 aliquots, we would expect the RSD for the composite to be about 20% ($80\% / \sqrt{16}$). This assumes that analytical error is small compared to sampling error, a condition we have found in our studies (Jenkins et al. 1997b). This also assumes perfect mixing of the 16 aliquots, which we know is

not possible. However, if 20- × 20-cm samples are taken from the 0- to 5-cm depth (via a scoop or shovel), the larger volume compared to a 5.6-cm-diameter core sample might cancel the effect of imperfect mixing.

Let's divide the unit into eight 25- × 25-m grids and then divide each grid into sixteen 6.25- × 6.25-m subgrids. One 20- × 20-cm aliquot from each subgrid would be formed into a single pile, homogenized as described earlier (section 5), and a representative 200- to 400-g area-integrated sample would be carefully collected. Duplicate 20-g subsamples would be analyzed on-site to yield eight mean concentration estimates. If greater precision and accuracy are required, duplicate samples could be collected from the pile.

When the objective is to produce a mean and upper confidence limit for an entire remediation unit, compositing could go as follows. Two 20- × 20-cm aliquots would be collected from each of the eight grids, and sampled as described above. Replicate composites, each containing 16 aliquots, could be prepared and 20-g subsamples analyzed. The number of composites required will vary with the precision specified for the mean. Aliquot locations within subgrids could be made randomly or systematically.

From the above discussion, it should be clear that each site will require decisions that are based on the preliminary study and coupled to data quality objectives. As results accumulate, the transition from preliminary study to full-scale sampling should become more efficient and reliable.

APPENDIX B: RP-HPLC ANALYSIS DATA FROM FORT ORD SAMPLES

Table B1. 18-19 August 1997 from sampling area 1-44.

Site	Depth (cm)	Concentration (mg/kg)				
		HMX	RDX	TNT	4-AmDNT	2-AmDNT
1-44- 1	0-15	273(250)	0.50 (1.7)	0.10* (0.59)	1.08 (1.46)	0.90(1.31)
1	15-30	0.68	ND†	ND	ND	ND
1	30-45	0.65	ND	ND	ND	ND
1	45-60	0.70	ND	ND	ND	ND
1	105-120	7.01	ND	ND	0.09*	0.09*
1-44- 2	0-15	302	0.55	0.05*	1.24	0.99
2	15-30	1.00	0.06*	ND	0.04*	ND
2	30-45	0.41	ND	ND	ND	ND
2	45-60	0.25	ND	ND	ND	ND
2	105-120	0.37	ND	ND	ND	ND
1-44- 3	0-15	479	0.19*	0.23*	0.43	0.20*
3	15-30	4.29	ND	ND	0.04*	0.03*
3	30-45	1.31 (0.81)	ND	ND	ND	ND
3	45-60	0.24*	ND	ND	ND	ND
3	105-120	2.01	ND	ND	ND	ND
1-44- 4	0-15	136	0.09*	0.06*	0.69	0.58
4	15-30	0.62	ND	ND	ND	MD
4	30-45	0.35	ND	ND	ND	ND
4	45-60	0.30	ND	ND	ND	ND
4	105-120	0.69	ND	ND	ND	ND
1-44- 5	0-15	587	0.26	0.06*	0.47	0.36
5	15-30	1.29	ND	ND	ND	ND
5	30-45	0.35	ND	ND	ND	ND
5	45-60	0.30	ND	ND	ND	ND
5	105-120	1.33 (1.36)**	ND	ND	ND	ND
1-44- 6	0-15	269	0.43	0.13*	0.65	0.50
6	15-30	45.1	0.10*	ND	0.69	0.58
6	30-45	0.78	ND	ND	ND	ND
6	45-60	0.31	ND	ND	ND	ND
6	105-120	4.91 (1.36)	ND	ND	ND	ND
1-44- 7	0-15	343	0.37	0.53	0.49	0.41
7	15-30	0.79	ND	ND	0.06*	0.04*
7	30-45	0.55	ND	ND	ND	ND
7	45-60	0.31	ND	ND	ND	ND
7	105-120	7.73	ND	ND	ND	ND
1-44- 8	0-15	81.4 (75.1)	0.08*(0.08*)	0.03*(0.03*)	0.23*(0.20*)	0.20*(0.16*)
8	15-30	26.8 (49.8)	ND	ND	0.08*(0.09*)	0.07*(0.07*)
8	30-45	0.83	0.04*	ND	ND	ND
8	45-60	0.24	ND	ND	ND	ND
8	105-120	0.28	ND	ND	ND	ND
1-44- 9	0-15	20.2	ND	ND	0.10*	0.07*
9	15-30	0.16*	ND	ND	ND	ND
9	30-45	0.09*	ND	ND	ND	ND
9	45-60	0.05*	ND	ND	ND	ND
9	105-120	ND	ND	ND	ND	ND

Table B1 (cont'd). 18-19 August 1997 from sampling area 1-44.

Site	Depth (cm)	Concentration (mg/kg)				
		HMX	RDX	TNT	4-AmDNT	2-AmDNT
1-44- 10	0-15	36.1	ND	ND	0.15*	0.19*
10	15-30	0.39	ND	ND	0.03*	0.02*
10	30-45	0.33	ND	ND	ND	ND
10	45-60	0.51	ND	ND	ND	ND
10	105-120	0.29	ND	ND	ND	ND
1-44- 11	0-15	204 (409)	<d (0.29)	0.06*(0.09*)	0.30 (0.36)	0.20*(0.25)
11	15-30	10.4	ND	ND	0.04*	ND
11	30-45	2.56	ND	ND	0.04*	0.02*
11	45-60	0.49	0.11*	ND	ND	ND
11	105-120	1.30	ND	ND	ND	ND
1-44- 12	0-15	74.3	0.14*	0.24*	0.37	0.48
12	15-30	0.21*(0.24*)	ND	ND	ND	ND
12	30-45	ND	ND	ND	ND	ND
12	45-60	ND	ND	ND	ND	ND
12	105-120	0.13*	ND	ND	ND	ND
1-44- 13	0-15	0.45 (0.19*)	ND	ND	ND	ND
13	15-30	ND	ND	ND	ND	ND
13	30-45	Sample lost - no analysis				
13	45-60	ND	ND	ND	ND	ND
13	105-120	ND	ND	ND	ND	ND
1-44- 14	0-15	4.28	ND	0.03*	ND	ND
14	15-30	ND	ND	ND	ND	ND
14	30-45	ND	ND	ND	ND	ND
14	45-60	ND	ND	ND	ND	ND
14	105-120	ND	ND	ND	ND	ND
1-44- 15	0-15	<d (0.48)	ND	ND	ND	ND
15	15-30	0.64	ND	ND	ND	ND
15	30-45	ND	ND	ND	ND	ND
15	45-60	ND	ND	ND	ND	ND
15	105-120	ND	ND	ND	ND	ND
1-44- 16	0-15	0.27 (1.56)	ND	ND	ND	ND
16	15-30	ND	ND	ND	ND	ND
16	30-45	ND	ND	ND	ND	ND
16	45-60	ND	ND	ND	ND	ND
16	105-120	ND	ND	ND	ND	ND

*Concentrations reported with an asterisk were below method detection limits (MDLs).

†No target analytes detected.

**Values given in parentheses were obtained from a second portion of soil from the same bag.

Table B2. 18-19 August 1997 from sampling area R-44.

Site	Depth (cm)	Concentration (mg/kg)				
		HMX	RDX	TNT	4-AmDNT	2-AmDNT
R-44- 1	0-15	ND*	ND	ND	ND	ND
1	15-30	ND	ND	ND	ND	ND
1	30-45	ND	ND	ND	ND	ND
1	45-60	ND	ND	ND	ND	ND
1	105-120	ND	ND	ND	ND	ND
R-44- 2	0-15	ND	ND	ND	ND	ND
2	15-30	ND	ND	ND	ND	ND
2	30-45	ND	ND	ND	ND	ND
2	45-60	ND	ND	ND	ND	ND
2	105-120	ND	ND	ND	ND	ND
R-44- 3	0-15	ND	ND	ND	ND	ND
3	15-30	ND	ND	ND	ND	ND
3	30-45	ND	ND	ND	ND	ND
3	45-60	ND	ND	ND	ND	ND
3	105-120	ND	ND	ND	ND	ND
R-44- 4	0-15	ND	ND	ND	ND	ND
4	15-30	ND	ND	ND	ND	ND
4	30-45	ND	ND	ND	ND	ND
4	45-60	ND	ND	ND	ND	ND
4	105-120	ND	ND	ND	ND	ND

*No target analytes detected.

Table B3. 18-19 August 1997 from sampling area 1-48.

Site	Depth (cm)	Concentration (mg/kg)				
		HMX	RDX	TNT	4-AmDNT	2-AmDNT
1-48- 1	0-15	1.43	0.23*	0.01*	0.08*	0.07*
	15-30	0.38	0.16*	ND	ND	ND
	30-45	1.18	0.18*	ND	0.05*	0.03*
	45-60	0.26	0.44	ND	0.02	ND
	105-120	0.39	ND†	ND	ND	ND
1-48- 2	0-15	1.17	0.07*	ND	0.08*	0.09*
	15-30	0.40	0.12*	ND	0.04*	0.03*
	30-45	0.96	0.19*	ND	0.08*	0.02*
	45-60	0.29	0.40	ND	ND	ND
	105-120	0.58	0.15*	ND	0.03*	ND
1-48- 3	0-15	0.05*	0.08*	ND	ND	ND
	15-30	ND	ND	ND	ND	ND
	30-45	ND	ND	ND	ND	ND
	45-60	ND	ND	ND	ND	ND
	105-120	0.31	0.05*	ND	ND	ND
1-48- 4	0-15	ND	ND	ND	0.03*	0.03*
	15-30	ND	0.11*	ND	ND	ND
	30-45	0.10*	ND	ND	0.03*	ND
	45-60	ND	ND	ND	ND	ND
	105-120	ND	ND	ND	ND	ND
1-48- 5	0-15	1.07	ND	ND	0.02*	ND
	15-30	0.68	ND	ND	ND	ND
	30-45	0.16*	ND	ND	ND	ND
	45-60	0.41	ND	ND	ND	ND
	105-120	ND	ND	ND	ND	ND
1-48- 6	0-15	0.34	ND	ND	ND	0.02*
	15-30	0.17*	ND	ND	ND	ND
	30-45	0.27	ND	ND	ND	ND
	45-60	ND	ND	ND	ND	ND
	105-120	ND	ND	ND	ND	ND
1-48- 7	0-15	ND	ND	ND	ND	ND
	15-30	0.19*	ND	ND	ND	ND
	30-45	0.14*	ND	ND	ND	ND
	45-60	ND	ND	ND	ND	ND
	105-120	ND	ND	ND	ND	ND
1-48- 8	0-15	ND	ND	ND	ND	ND
	15-30	0.22*	ND	ND	ND	ND
	30-45	ND	ND	ND	ND	ND
	45-60	0.20*	ND	ND	ND	ND
	105-120	ND	ND	ND	ND	ND
1-48- 9	0-15	ND	ND	ND	ND	ND
	15-30	ND	ND	ND	ND	ND
	30-45	ND	ND	ND	ND	ND
	45-60	ND	ND	ND	ND	ND
	105-120	ND	ND	ND	ND	ND

Table B3 (cont'd).

Site	Depth (cm)	Concentration (mg/kg)				
		HMX	RDX	TNT	4-AmDNT	2-AmDNT
1-48- 10	0-15	ND	ND	ND	ND	ND
10	15-30	ND	ND	ND	ND	ND
10	30-45	ND	ND	ND	ND	ND
10	45-60	ND	ND	ND	ND	ND
10	105-120	ND	ND	ND	ND	ND
1-48- 11	0-15	ND	ND	ND	ND	ND
11	15-30	ND	ND	ND	ND	ND
11	30-45	ND	ND	ND	ND	ND
11	45-60	ND	ND	ND	ND	ND
11	105-120	ND	ND	ND	ND	ND
1-48- 12	0-15	ND	ND	ND	ND	ND
12	15-30	ND	ND	ND	ND	ND
12	30-45	ND	ND	ND	ND	ND
12	45-60	ND	ND	ND	ND	ND
12	105-120	ND	ND	ND	ND	ND
1-48- 13	0-15	ND	ND	ND	ND	ND
13	15-30	ND	ND	ND	ND	ND
13	30-45	ND	ND	ND	ND	ND
13	45-60	0.46 (ND)**	ND	ND	0.05* (ND)	0.03* (ND)
13	105-120	ND	ND	ND	ND	ND
1-48- 14	0-15	ND	ND	ND	ND	ND
14	15-30	ND	ND	ND	ND	ND
14	30-45	ND	ND	ND	ND	ND
14	45-60	ND	ND	ND	ND	ND
14	105-120	ND	ND	ND	ND	ND
1-48- 15	0-15	ND	ND	ND	ND	ND
15	15-30	ND	ND	ND	ND	ND
15	30-45	ND	ND	ND	ND	ND
15	45-60	ND	ND	ND	ND	ND
15	105-120	ND	ND	ND	ND	ND
1-48- 16	0-15	ND	ND	ND	ND	ND
16	15-30	ND	ND	ND	ND	ND
16	30-45	ND	ND	ND	ND	ND
16	45-60	ND	ND	ND	ND	ND
16	105-120	ND	ND	ND	ND	ND

*Concentrations reported with an asterisk were below method detection limits (MDLs).

†No target analytes detected.

**Values given in parentheses were obtained from a second portion of soil from the same bag.

Table B4. 18-19 August 1997 from sampling area 2-48.

Site	Depth (cm)	Concentration (mg/kg)				
		HMX	RDX	TNT	4-AmDNT	2-AmDNT
2-48- 1	0-15	ND†	ND	0.03*	0.04*	0.04*
	15-30	ND	ND	0.01*	0.04*	0.05*
	30-45	ND	ND	ND	ND	ND
	45-60	ND	ND	ND	ND	ND
	105-120	ND	ND	ND	ND	ND
2-48- 2	0-15	ND	ND	ND	0.08*	0.07*
	15-30	ND	ND	ND	ND	ND
	30-45	ND	ND	0.02*	0.03*	0.02*
	45-60	ND	ND	0.01*	ND	0.02*
	105-120	ND	ND	ND	ND	ND
2-48- 3	0-15	ND	ND	0.01*	0.06*	0.03*
	15-30	ND	ND	0.03*	0.05*	0.06*
	30-45	ND	ND	ND	ND	ND
	45-60	ND	ND	ND	ND	ND
	105-120	ND	ND	ND	ND	ND
2-48- 4	0-15	ND	ND	0.11*	0.16*	0.13*
	15-30	ND	ND	0.04*	ND	0.03*
	30-45	ND	ND	0.02*	0.03*	0.02*
	45-60	ND	ND	ND	ND	ND
	105-120	ND	ND	ND	ND	ND
2-48- 5	0-15	ND	ND	ND	ND	ND
	15-30	ND	ND	ND	ND	ND
	30-45	ND	ND	ND	ND	0.02*(0.02*)**
	45-60	ND	ND	ND	0.02*	0.03*
	105-120	ND	ND	ND	ND	ND
2-48- 6	0-15	ND	ND	ND	ND	ND
	15-30	ND	ND	ND	ND	ND
	30-45	ND	ND	0.09*	ND	0.04*
	45-60	ND	ND	ND	ND	ND
	105-120	ND	ND	ND	ND	ND
2-48- 7	0-15	ND	ND	ND	ND	ND
	15-30	ND	ND	ND	0.03*	0.04*
	30-45	ND	ND	ND	ND	ND
	45-60	ND	ND	ND	ND	ND
	105-120	ND	ND	ND	ND	ND
2-48- 8	0-15	ND	ND	ND	ND	ND
	15-30	ND	ND	ND	ND	0.02*
	30-45	ND	ND	ND	ND	ND
	45-60	ND	ND	ND	ND	ND
	105-120	ND	ND	ND	ND	ND
2-48- 9	0-15	ND	ND	ND	ND	ND
	15-30	ND	ND	ND	ND	ND
	30-45	ND	ND	ND	ND	0.02*
	45-60	ND	ND	ND	ND	ND
	105-120	ND	ND	0.05*	ND	ND

Table B4 (cont'd).

Site	Depth (cm)	Concentration (mg/kg)				
		HMX	RDX	TNT	4-AmDNT	2-AmDNT
2-48- 10	0-15	ND	ND	ND	ND	ND
	10	ND	ND	ND	ND	ND
	10	ND	ND	ND	ND	ND
	10	ND	ND	ND	ND	ND
	10	105-120	ND	ND	ND	ND
2-48- 11	0-15	ND	ND	ND	ND	ND
	11	ND	ND	ND	ND	ND
	11	ND	ND	ND	ND	ND
	11	ND	ND	ND	ND	ND
	11	105-120	ND	ND	ND	ND
2-48- 12	0-15	ND	ND	0.05*	ND	ND
	12	ND	ND	ND	ND	ND
	12	ND	ND	ND	ND	ND
	12	ND	ND	ND	ND	ND
	12	105-120	ND	ND	ND	ND
2-48- 13	0-15	ND	ND	ND	ND	ND
	13	ND	ND	0.01*	ND	ND
	13	ND	ND	ND	ND	ND
	13	ND	ND	ND	ND	ND
	13	105-120	ND	ND	ND	ND
2-48- 14	0-15	ND	ND	ND	ND	ND
	14	ND	ND	ND	ND	ND
	14	ND	ND	ND	ND	ND
	14	ND	ND	ND	ND	ND
	14	105-120	ND	ND	ND	ND
2-48- 15	0-15	ND	ND	ND	ND	ND
	15	ND	ND	ND	ND	ND
	15	ND	ND	ND	ND	ND
	15	ND	ND	ND	ND	ND
	15	105-120	ND	ND	ND	ND
2-48- 16	0-15	ND	ND	ND	ND	ND
	16	ND	ND	ND	ND	ND
	16	ND	ND	ND	ND	ND
	16	ND	ND	ND	ND	ND
	16	105-120	ND	ND	ND	ND

*Concentrations reported with an asterisk were below method detection limits (MDLs).

†No target analytes detected.

**Values given in parentheses were obtained from a second portion of soil from the same bag.

Table B5. 18–19 August 1997 from sampling area R-48.

Site	Depth (cm)	Concentration (mg/kg)				
		HMX	RDX	TNT	4-AmDNT	2-AmDNT
R-48- 1	0–15	ND*	ND	ND	ND	ND
1	15–30	ND	ND	ND	ND	ND
1	30–45	ND	ND	ND	ND	ND
1	45–60	ND	ND	ND	ND	ND
1	105–120	ND	ND	ND	ND	ND
R-48- 2	0–15	ND	ND	ND	ND	ND
2	15–30	ND	ND	ND	ND	ND
2	30–45	ND	ND	ND	ND	ND
2	45–60	ND	ND	ND	ND	ND
2	105–120	Sample lost—no analysis for this sample				
R-48- 3	0–15	ND	ND	ND	ND	ND
3	15–30	ND	ND	ND	ND	ND
3	30–45	ND	ND	ND	ND	ND
3	45–60	ND	ND	ND	ND	ND
3	105–120	ND	ND	ND	ND	ND
R-48- 4	0–15	ND	ND	ND	ND	ND
4	15–30	ND	ND	ND	ND	ND
4	30–45	ND	ND	ND	ND	ND
4	45–60	ND	ND	ND	ND	ND
4	105–120	ND	ND	ND	ND	ND

*No target analytes detected.

Table B6. Spike/recovery samples (all spikes at 0.5 mg/kg; 4-AmDNT not spiked).

Site	Depth (cm)	Concentration (mg/kg)								
		HMX	RDX	TNT	4-AmDNT	2-AmDNT	DNB	TNB	NB	2,4-DNT
R-48-2	30–45	0.47	0.48	0.48	ND†	0.49	0.44	0.43	0.44	0.48
1-44-6	105–120	0.44	0.46	0.47	ND	0.47	0.45	0.40	0.48	0.51
2-48-15	15–30	0.52	0.46	0.47	ND	0.50	0.50	0.48	0.51	0.51
2-48-16	105–120	0.58	0.52	0.50	ND	0.49	0.50	0.51	0.51	0.52
2-48-10	105–120	0.49	0.50	0.50	ND	0.50	0.51	0.51	0.52	0.53
1-48-11	105–120	0.45	0.53	0.45	ND	0.49	0.51	0.47	0.51	0.54
2-48-15	105–120	0.49	0.54	0.47	ND	0.54	0.51	0.50	0.51	0.53
1-44-12	105–120	1.01*	0.52	0.49	ND	0.52	0.49	0.42	0.50	0.51
R-44-4	105–120	0.45	0.55	0.53	ND	0.54	0.46	0.51	0.51	0.51

*This sample contained HMX prior to spiking.

†No target analytes detected.

REPORT DOCUMENTATION PAGE

Form Approved
OMB No. 0704-0188

Public reporting burden for this collection of information is estimated to average 1 hour per response, including the time for reviewing instructions, searching existing data sources, gathering and maintaining the data needed, and completing and reviewing the collection of information. Send comments regarding this burden estimate or any other aspect of this collection of information, including suggestion for reducing this burden, to Washington Headquarters Services, Directorate for Information Operations and Reports, 1215 Jefferson Davis Highway, Suite 1204, Arlington, VA 22202-4302, and to the Office of Management and Budget, Paperwork Reduction Project (0704-0188), Washington, DC 20503.

1. AGENCY USE ONLY (Leave blank)		2. REPORT DATE August 1998		3. REPORT TYPE AND DATES COVERED	
4. TITLE AND SUBTITLE Site Characterization for Explosives Contamination at a Military Firing Range Impact Area				5. FUNDING NUMBERS	
6. AUTHORS Thomas F. Jenkins, Marianne E. Walsh, Philip G. Thorne, Paul H. Miyares, Thomas A. Ranney, Clarence L. Grant, and John R. Esparza					
7. PERFORMING ORGANIZATION NAME(S) AND ADDRESS(ES) U.S. Army Cold Regions Research and Engineering Laboratory 72 Lyme Road Hanover, New Hampshire 03755				8. PERFORMING ORGANIZATION REPORT NUMBER Special Report 98-9	
9. SPONSORING/MONITORING AGENCY NAME(S) AND ADDRESS(ES) U.S. Army Engineer District Sacramento, California				10. SPONSORING/MONITORING AGENCY REPORT NUMBER SFIM-A-EC-ET-CR-98025	
				U.S. Army Environmental Center Aberdeen Proving Ground, Maryland	
11. SUPPLEMENTARY NOTES For conversion of SI units to non-SI units of measurement, consult ASTM Standard E380-93, <i>Standard Practice for Use of the International System of Units</i> , published by the American Society for Testing and Materials, 100 Barr Harbor Drive, West Conshohocken, PA 19428-2959.					
12a. DISTRIBUTION/AVAILABILITY STATEMENT Approved for public release; distribution is unlimited. Available from NTIS, Springfield, Virginia 22161				12b. DISTRIBUTION CODE	
13. ABSTRACT (<i>Maximum 200 words</i>) A study was conducted at the inland firing ranges at Fort Ord to determine the current levels of explosives residues and to recommend appropriate future site characterization techniques. A set of 280 soil samples was collected from depths ranging from 0-15 cm to 105-120 cm from anti-tank ranges 44 and 48. Sampling locations were selected on the basis of the locations of current and former targets, and included an area away from specific targets and a background area, not affected by local detonations. HMX was the explosives residue present at the highest concentration. Much lower concentrations of RDX, TNT, and two isomers of aminodinitrotoluene were also detected. Explosives residues were largely confined to surface soils near tank targets. A major problem for site characterization was found to be the large spatial heterogeneity present. Composite samples very effectively provided representative samples for 5- x 5-m size grids. A colorimetric on-site method gave reliable results for HMX, relative to SW846 Method 8330. No currently available on-site method for RDX was found to be adequate in the presence of much higher concentrations of HMX.					
14. SUBJECT TERMS Anti-tank range Compositing Explosives				15. NUMBER OF PAGES 46	
Firing range HMX Impact area				16. PRICE CODE	
Sampling Soil Spatial heterogeneity					
17. SECURITY CLASSIFICATION OF REPORT UNCLASSIFIED		18. SECURITY CLASSIFICATION OF THIS PAGE UNCLASSIFIED		19. SECURITY CLASSIFICATION OF ABSTRACT UNCLASSIFIED	
				20. LIMITATION OF ABSTRACT UL	