

Technical Report

August 1998



Pan American Climate Study (PACS)

Mooring Recovery and Deployment Cruise Report
R/V Thomas Thompson Cruise Number 73
28 November to 26 December 1997

by

Richard P. Trask
Robert A. Weller
William M. Ostrom
Bryan S. Way

August 1998

19980921 053



Upper Ocean Processes Group
Woods Hole Oceanographic Institution
Woods Hole, Massachusetts 02543

UOP Technical Report 98-02

THIS COPY IS DELETED 1

WHOI-98-18
UOP 98-02

**Pan American Climate Study (PACS)
Mooring Recovery and Deployment Cruise Report
R/V Thomas Thompson Cruise Number 73
28 November to 26 December 1997**

by

Richard P. Trask
Robert A. Weller
William M. Ostrom
Bryan S. Way

Technical Report

Woods Hole Oceanographic Institution
Woods Hole, Massachusetts 02543

August 1998

Funding was provided by the National Oceanic and Atmospheric Administration
under Contract No. NA66GPO130

Reproduction in whole or in part is permitted for any purpose of the United States
Government. This report should be cited as Woods Hole Oceanog. Inst. Tech. Rept.,
WHOI-98-18.

Approved for public release; distribution unlimited.

Approved for Distribution:

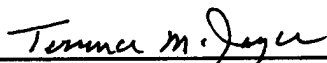

Terrence M. Joyce, Chair

Department of Physical Oceanography

Abstract

Three surface moorings were recovered and redeployed during *R/V Thomas Thompson* cruise number 73 in the eastern equatorial Pacific as part of the Pan American Climate Study (PACS). PACS is a NOAA-funded study with the goal of investigating links between sea-surface temperature variability in the tropical oceans near the Americas and climate over the American continents. The three moorings were deployed near 125°W, spanning the strong meridional sea-surface temperature gradient associated with the cold tongue south of the equator and the warmer ocean north of the equator, near the northernmost, summer location of the Intertropical Convergence Zone. The moored array was deployed to improve the understanding of air-sea fluxes and of the processes that control the evolution of the sea surface temperature field in the region.

Two surface moorings, located at 3°S, 125°W and 10°N, 125°W, belonging to the Upper Ocean Processes (UOP) Group at the Woods Hole Oceanographic Institution (WHOI), were recovered after being on station for eight months and redeployed. Two eight-month deployments were planned. A third mooring deployed at the equator and 128°W by the Ocean Circulation Group at the University of South Florida (USF) was also recovered and redeployed. The USF mooring, unfortunately, had to be recovered immediately following redeployment due to a problem with the buoy and instrumentation.

The buoys of the two WHOI moorings were each equipped with meteorological instrumentation, including a Vector Averaging Wind Recorder (VAWR), and an Improved METeorological (IMET) system. The WHOI moorings also carried Vector Measuring Current Meters, single point temperature recorders, and conductivity and temperature recorders located in the upper 200 meters of the mooring line. In addition to the instrumentation noted above, a variety of other instruments, including an acoustic current meter, acoustic doppler current meters, bio-optical instrument packages and an acoustic rain gauge, were deployed during the PACS field program. The USF mooring had an IMET system on the surface buoy and for oceanographic instrumentation, two RD Instruments acoustic doppler current profilers (ADCPs), single-point temperature recorders, and conductivity and temperature recorders. Conductivity-temperature-depth (CTD) profiles were made at each mooring site and during the transit between mooring locations.

This report describes, in a general manner, the work that took place during *R/V Thomas Thompson* cruise number 73. A description of the WHOI moored array and instrumentation is provided. Details of the mooring designs and preliminary data from the CTD profiles are included.

Table of Contents

ABSTRACT	1
LIST OF FIGURES	5
LIST OF TABLES	7
SECTION 1: INTRODUCTION	8
SECTION 2: THE MOORED ARRAY.....	10
A. WHOI SURFACE MOORINGS.....	10
1. Meteorological Instrumentation.....	20
a. Vector Averaging Wind Recorder.....	21
b. Improved METeorological System.....	21
c. Stand-alone Precipitation Instrument.....	29
d. VOS IMET Relative Humidity with Temperature Instrument.....	29
e. Stand-alone Relative Humidity/Air Temperature Instrument.....	30
2. Sub-Surface Instrumentation.....	30
a. Mooring Tension Recorder and Buoy Acceleration.....	30
b. Sub-surface Argos Transmitter.....	30
c. SEACAT Conductivity and Temperature Recorders.....	32
d. MicroCAT Conductivity and Temperature Recorder.....	32
e. Brancker Temperature Recorders.....	32
f. Miniature Temperature Recorder.....	32
g. WHOI Vector Measuring Current Meters.....	33
h. WaDaR Temperature Recorder.....	33
i. FSI Current Meter.....	34
j. Sherman Current Meter.....	34
k. Chlorophyll Absorption Meter.....	34
l. Bio-optical Package.....	35
m. Acoustic Rain Gauge.....	35
n. Acoustic Release.....	35
B. USF SURFACE MOORING AND INSTRUMENTATION.....	35
C. OTHER INSTRUMENTATION.....	37
1. WHOI Shipboard Meteorological System.....	37
2. SOLO Drifters.....	38
SECTION 3: CRUISE CHRONOLOGY.....	38
ACKNOWLEDGMENTS.....	45
REFERENCES	45
APPENDIX 1: CRUISE PARTICIPANTS.....	47
APPENDIX 2: CTD STATIONS OCCUPIED DURING TN 073.....	48
APPENDIX 3: INSTRUMENT TIME MARKS.....	67
APPENDIX 4: WHOI INSTRUMENTATION DEPLOYED DURING PACS 1 AND 2.....	70
APPENDIX 5: WIND DIRECTION SENSOR COMPARISON TESTS.....	75

APPENDIX 6: VMCM RECORD FORMAT	80
APPENDIX 7: DRAGGING OPERATIONS.....	81
APPENDIX 8: MOORING DEPLOYMENT OPERATIONS	85
APPENDIX 9: PACS ANTIFOULING COATING TEST	98

List of Figures

FIGURE 1: PACS MOORING CRUISE SCHEDULE.....	8
FIGURE 2: CRUISE TRACK AND MOORING LOCATIONS.....	9
FIGURE 3: WHOI PACS 1 NORTH MOORING SCHEMATIC.....	11
FIGURE 4: WHOI PACS 1 SOUTH MOORING SCHEMATIC.....	12
FIGURE 5: WHOI PACS 2 NORTH MOORING SCHEMATIC.....	13
FIGURE 6: WHOI PACS 2 SOUTH MOORING SCHEMATIC.....	14
FIGURE 7: PACS 1 NORTH DISCUS BUOY WITH TOWER AND BRIDLE INSTRUMENTATION.....	15
FIGURE 8: PACS 1 SOUTH DISCUS BUOY WITH TOWER AND BRIDLE INSTRUMENTATION.....	16
FIGURE 9: PACS 2 NORTH DISCUS BUOY WITH TOWER AND BRIDLE INSTRUMENTATION.....	17
FIGURE 10: PACS 2 SOUTH DISCUS BUOY WITH TOWER AND BRIDLE INSTRUMENTATION.....	18
FIGURE 11: (TOP) PACS 1 METEOROLOGICAL INSTRUMENT PLACEMENT ON BUOY TOWER TOP.....	22
FIGURE 12: (BOTTOM) PACS 2 METEOROLOGICAL INSTRUMENT PLACEMENT ON BUOY TOWER TOP.....	22
FIGURE 13: UNIVERSITY OF SOUTH FLORIDA MOORING SCHEMATIC.....	36
FIGURE 14: BOW MOUNT FOR INFRARED SEA SURFACE TEMPERATURE SENSOR.....	39
FIGURE 15: PACS 2 SOUTH ACOUSTIC RELEASE SURVEY.....	42
FIGURE 16: PACS 2 NORTH ACOUSTIC RELEASE SURVEY.....	44
FIGURE A2-1: CHART SHOWING CTD STATION LOCATIONS.....	50
FIGURE A2-2: COMPOSITE PLOT OF CTD DATA TAKEN DURING TN 073.....	51
FIGURE A2-3: PROFILES OF POTENTIAL TEMPERATURE, SALINITY AND SIGMA-T, CTD STATIONS 1 & 2... 52	52
FIGURE A2-4: PROFILES FROM CTD STATIONS 3 AND 4.....	53
FIGURE A2-5: PROFILES FROM CTD STATIONS 5 AND 6.....	54
FIGURE A2-6: PROFILES FROM CTD STATIONS 7 AND 8.....	55
FIGURE A2-7: PROFILES FROM CTD STATIONS 9 AND 10.....	56
FIGURE A2-8: PROFILES FROM CTD STATIONS 11 AND 12.....	57
FIGURE A2-9: PROFILES FROM CTD STATIONS 13 AND 14.....	58
FIGURE A2-10: PROFILES FROM CTD STATIONS 15 AND 16.....	59
FIGURE A2-11: PROFILES FROM CTD STATIONS 17 AND 18.....	60
FIGURE A2-12: PROFILES FROM CTD STATIONS 19 AND 20.....	61
FIGURE A2-13: PROFILES FROM CTD STATIONS 21 AND 22.....	62
FIGURE A2-14: PROFILES FROM CTD STATIONS 23 AND 24.....	63
FIGURE A2-15: PROFILES FROM CTD STATIONS 25 AND 26.....	64
FIGURE A2-16: PROFILES FROM CTD STATIONS 27 AND 28.....	65
FIGURE A2-17: PROFILES FROM CTD STATIONS 29 AND 30.....	66
FIGURE A5-1: WIND DIRECTION COMPARISON TESTS, PACS 2 NORTH.....	76
FIGURE A5-2: WIND DIRECTION COMPARISON TESTS, PACS 2 SOUTH.....	77
FIGURE A5-3: WIND COMPARISON TESTS (HAWAII), PACS 2 NORTH.....	78
FIGURE A5-4: WIND COMPARISON TESTS (HAWAII), PACS 2 SOUTH.....	79
FIGURE A7-1: SCHEMATIC OF DRAGGING STRATEGY DURING TN 073.....	82
FIGURE A7-2: TRAWL WIRE CONFIGURATION DURING DRAGGING OPERATIONS.....	83
FIGURE A8-1: DECK LAYOUT, TN 073.....	86
FIGURE A8-2: PERSONNEL POSITIONING, LOWERING PHASE SURFACE MOORING DEPLOYMENT.....	87
FIGURE A8-3: DISCUS BUOY BAIL CONFIGURATION.....	89
FIGURE A8-4: DECK LAYOUT FOLLOWING PACS 1 SOUTH RECOVERY.....	92
FIGURE A8-5: DECK LAYOUT PRIOR TO PACS 2 SOUTH DEPLOYMENT.....	93
FIGURE A8-6: DECK LAYOUT FOLLOWING PACS 1 USF MOORING RECOVERY.....	94
FIGURE A8-7: DECK LAYOUT PRIOR TO PACS 2 USF MOORING DEPLOYMENT.....	95
FIGURE A8-8: DECK LAYOUT FOLLOWING PACS 1 NORTH RECOVERY.....	96
FIGURE A8-9: DECK LAYOUT PRIOR TO PACS 2 NORTH DEPLOYMENT.....	97

FIGURE A9-1: ANTIFOULING PAINT TEST LOCATIONS, PACS 1 NORTH AND SOUTH DISCUS BUOY HULLS.99
FIGURE A9-2: ANTIFOULING PAINT TEST LOCATIONS, PACS 2 NORTH BUOY HULL.....102
FIGURE A9-3: ANTIFOULING PAINT TEST LOCATIONS, PACS 2 SOUTH BUOY HULL.....103

List of Tables

TABLE 1: PACS 1 MOORING DEPLOYMENT/RECOVERY INFORMATION	9
TABLE 2: PACS 2 MOORING DEPLOYMENT INFORMATION.....	10
TABLE 3: PACS 1 NORTH DISCUS BUOY-MOUNTED SENSORS AND CORRESPONDING ELEVATIONS.	23
TABLE 4: PACS 1 SOUTH DISCUS BUOY-MOUNTED SENSORS AND CORRESPONDING ELEVATIONS.	24
TABLE 5: PACS 2 NORTH DISCUS BUOY-MOUNTED SENSORS AND CORRESPONDING ELEVATIONS.	25
TABLE 6: PACS 2 SOUTH DISCUS BUOY-MOUNTED SENSORS AND CORRESPONDING ELEVATIONS.	26
TABLE 7: VAWR SENSOR SPECIFICATIONS.....	27
TABLE 8: IMET SENSOR SPECIFICATIONS.....	28
TABLE 9: PACS 2 SUB-SURFACE INSTRUMENTATION.....	31
TABLE 10: SOLO FLOAT DEPLOYMENT TIMES AND POSITIONS.....	40
TABLE A2-1: CTD STATIONS TAKEN DURING TN 073	49
TABLE A8-1: WINCH PAYOUT METER READINGS FOR DIFFERENT SHIP SPEEDS.	91
TABLE A9-1: ANTIFOULING COATING PERFORMANCE, PACS 1, NORTH AND SOUTH.....	100
TABLE A9-2: ANTIFOULING COATINGS TESTED, PACS 2 NORTH.....	101

Section 1: Introduction

The R/V *Thomas Thompson* cruise number 73 (TN 073) departed Honolulu, Hawaii, on 28 November 1997, at 1700 hours UTC. The purpose of the cruise was to recover and redeploy two Woods Hole Oceanographic Institution (WHOI) surface moorings and one University of South Florida (USF) surface mooring. All of the moorings were part of the Pan American Climate (PACS) Study funded by the National Oceanic and Atmospheric Administration (NOAA). This was the second of three cruises planned for the experiment. The final recovery of all moorings is planned for September/October 1998. The PACS cruise schedule is shown in Figure 1.

The cruise involved personnel from the Upper Ocean Processes (UOP) Group at WHOI, and personnel from USF. Appendix 1 lists the cruise participants. Figure 2 shows the cruise track and the mooring locations; Table 1 lists the deployment and recovery dates for the first setting of the moored array (referred to as PACS 1) as well as the surveyed anchor positions; and Table 2 lists the deployment dates and positions of the moorings that were redeployed during TN 073. The second deployment of the PACS moorings is referred to as PACS 2.

Four Sounding Oceanographic Langrangian Observer (SOLO) instruments belonging to Scripps Institution of Oceanography (SIO) were deployed during the cruise. A total of 31 conductivity-temperature-depth (CTD) casts were made throughout the cruise. Appendix 2 contains a listing of the CTD positions, start times and maximum depth of the stations, as well as a plot of the CTD station locations.

This report has a total of three sections including this brief introduction. The second section describes the PACS moored array with emphasis on the WHOI moorings and their instrumentation. This section also includes a description of the USF moorings and their instrumentation. The third section presents a chronology of the cruise.

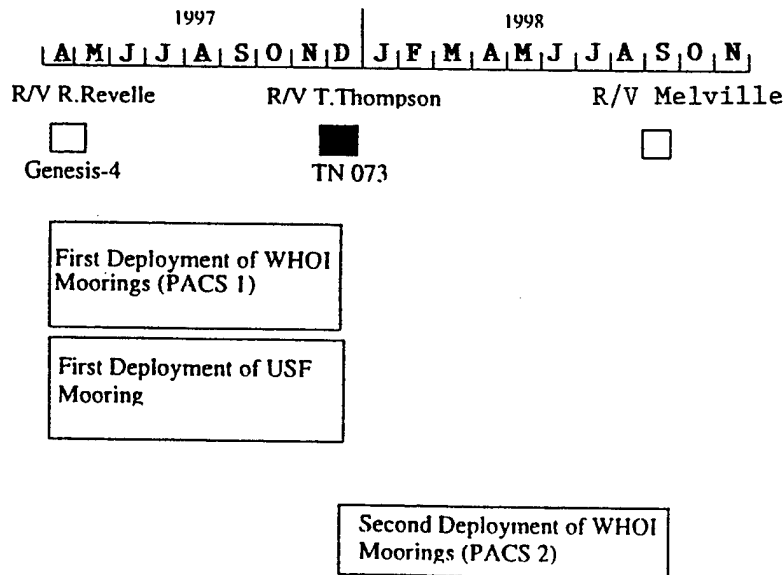

Figure 1: PACS mooring cruise schedule.

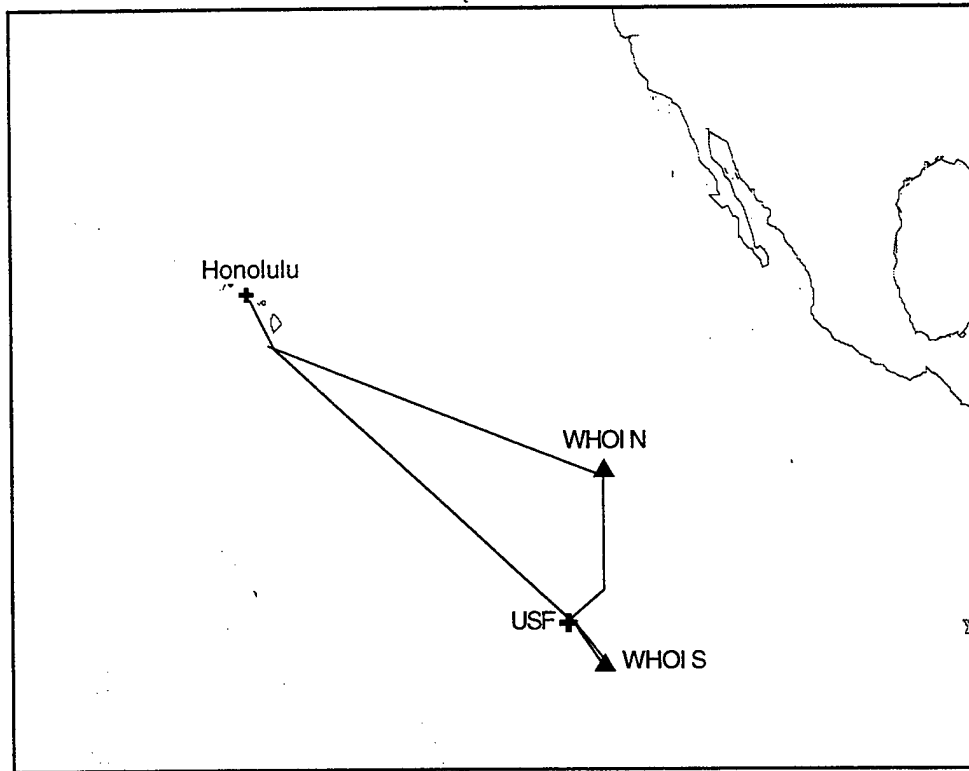

Figure 2: Cruise track and mooring locations.

Table 1: PACS 1 mooring deployment/recovery information

Mooring	Deployment Date and Time	Recovery Date	Anchor Position
WHOI PACS - South Discus Buoy (WHOI Moor. Reference No. 1014)	21 April 1997 @0002 UTC	7 December 1997 @1548 UTC	2°46.78'S 124°39.38'W
USF Toroid Buoy	24 April 1997 @2154 UTC	10 December 1997 @ 1828 UTC	00°00.39'N 127°58.34'W
WHOI PACS - North Discus Buoy (WHOI Moor. Reference No. 1015)	29 April 1997 @2135 UTC	17 December 1997 @ 1533 UTC	9°58.99'N 125°23.39'W

Table 2: PACS 2 mooring deployment information

Mooring	Deployment Date and Time	Anchor Position
WHOI PACS South Discus Buoy WHOI Mooring Reference No. 1020	9 December 1997 @ 0036 UTC	2° 46.231' S 124° 39.733' W
WHOI PACS North Discus Buoy WHOI Mooring Reference No. 1021	19 December 1997 @ 0119 UTC	9° 55.787' N 125° 24.772' W

Section 2: The Moored Array

Three surface moorings, previously deployed during the Genesis 4 cruise of the R/V *Roger Revelle* in April 1997, were recovered and redeployed during TN 073. Two of the three moorings were prepared and deployed by the UOP Group at WHOI. The WHOI moorings were nominally located in the eastern Pacific at latitudes 10°N and 3°S along longitude 125°W. In this report the WHOI moorings are referred to as either North or South. The first deployment of WHOI moorings is referred to as the PACS 1 moorings and the second deployment as PACS 2. Therefore, there is a PACS 1 North and South mooring and a PACS 2 North and South mooring. Both WHOI moorings from both the PACS 1 and 2 deployments were heavily instrumented with both meteorological and oceanographic instrumentation. The third mooring was prepared by personnel from the Ocean Circulation Group at USF. The USF mooring was deployed on the equator to the west of the WHOI moorings. Details about the WHOI moorings and the USF mooring can be found below in their respective sections.

A. WHOI Surface Moorings

The PACS 1 North and South moorings are shown schematically in Figures 3 and 4 respectively. The PACS 2 North and South mooring drawings are shown in Figures 5 and 6 respectively. The WHOI moorings are an inverse catenary design utilizing wire rope, chain, nylon and polypropylene line. Each mooring has a scope of 1.22 (Scope = mooring slack length/water depth). The surface buoy is a three-meter diameter discus buoy with a two-part aluminum tower and rigid bridle. Figures 7 and 8 schematically show the PACS 1 North and South discus buoys respectively with both tower- and bridle-mounted instrumentation. Figures 9 and 10 schematically show the PACS 2 North and South discus buoys respectively.

The design of the WHOI surface moorings took into consideration the predicted currents, winds, and sea state conditions expected during the deployment duration. Further they they were constructed using hardware and designs already proven in the recent Arabian Sea deployment.

MAXIMUM DIAMETER OF BUOY
WATCH CIRCLE = 4.0 N. MILES

3 meter Discus Buoy with, VAWR and IMET,
Both with Argos Telemetry, Stand-Alone Rel.
Hum./Air Temp. Sensor, and Floating Sea
Surface Temperature Sensor

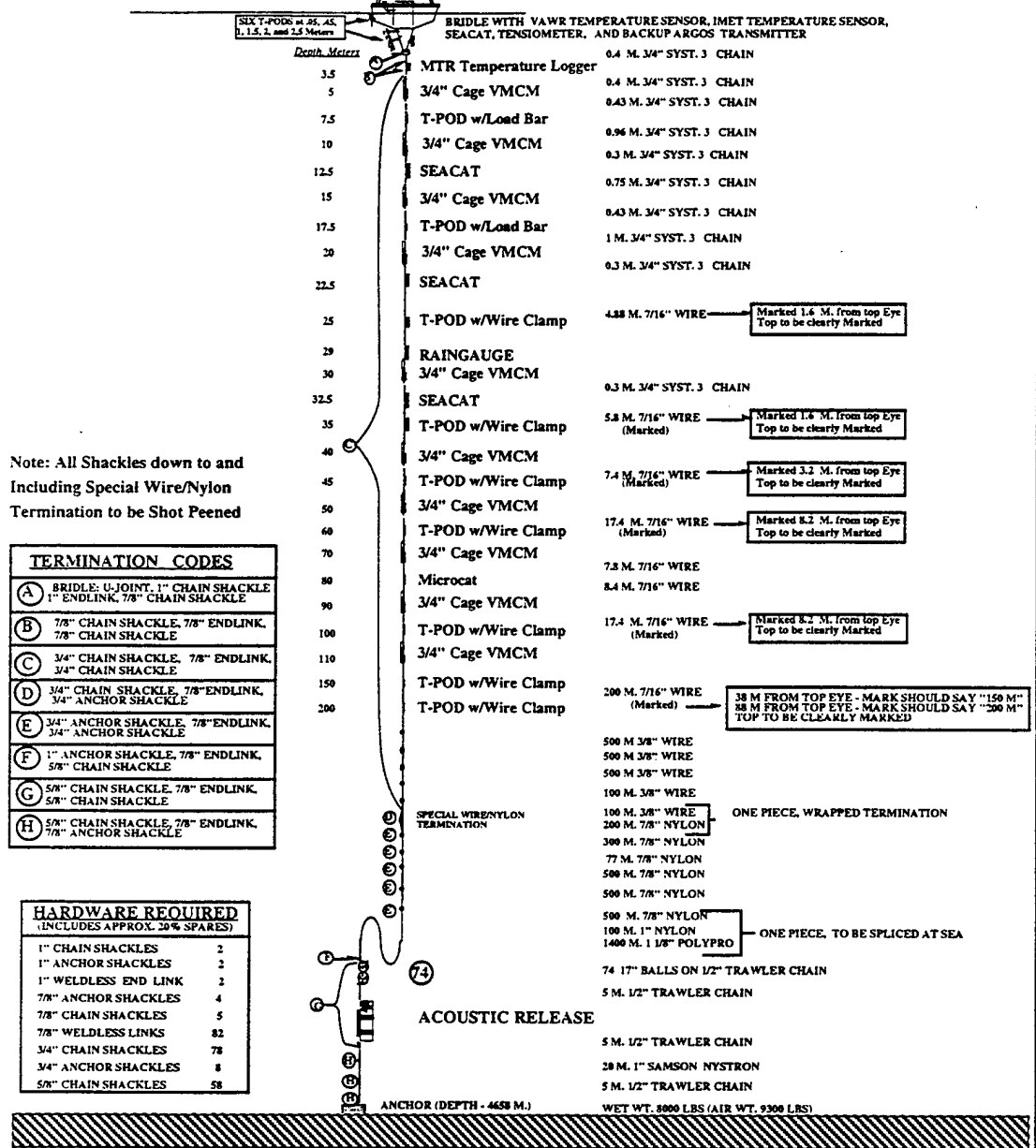

Note: All Shackles down to and Including Special Wire/Nylon Termination to be Shot Peened

TERMINATION CODES	
(A)	BRIDLE: U-JOINT, 1" CHAIN SHACKLE, 1" ENDLINK, 7/8" CHAIN SHACKLE
(B)	7/8" CHAIN SHACKLE, 7/8" ENDLINK, 7/8" CHAIN SHACKLE
(C)	3/4" CHAIN SHACKLE, 7/8" ENDLINK, 3/4" CHAIN SHACKLE
(D)	3/4" CHAIN SHACKLE, 7/8" ENDLINK, 3/4" ANCHOR SHACKLE
(E)	3/4" ANCHOR SHACKLE, 7/8" ENDLINK, 3/4" ANCHOR SHACKLE
(F)	1" ANCHOR SHACKLE, 7/8" ENDLINK, 5/8" CHAIN SHACKLE
(G)	5/8" CHAIN SHACKLE, 7/8" ENDLINK, 5/8" CHAIN SHACKLE
(H)	5/8" CHAIN SHACKLE, 7/8" ENDLINK, 7/8" ANCHOR SHACKLE

HARDWARE REQUIRED (INCLUDES APPROX. 20% SPARES)	
1" CHAIN SHACKLES	2
1" ANCHOR SHACKLES	2
1" WELDLESS END LINK	2
7/8" ANCHOR SHACKLES	4
7/8" CHAIN SHACKLES	5
7/8" WELDLESS LINKS	82
3/4" CHAIN SHACKLES	78
3/4" ANCHOR SHACKLES	8
5/8" CHAIN SHACKLES	58

Figure 3: WHOI PACS 1 North mooring schematic

MAXIMUM DIAMETER OF BUOY
WATCH CIRCLE = 4.1 N. MILES

3 meter Discus Buoy with, VAWR and IMET,
Both with Argos Telemetry, Stand-Alone Rel.
Hum./Air Temp. Sensor, and Floating Sea
Surface Temperature Sensor

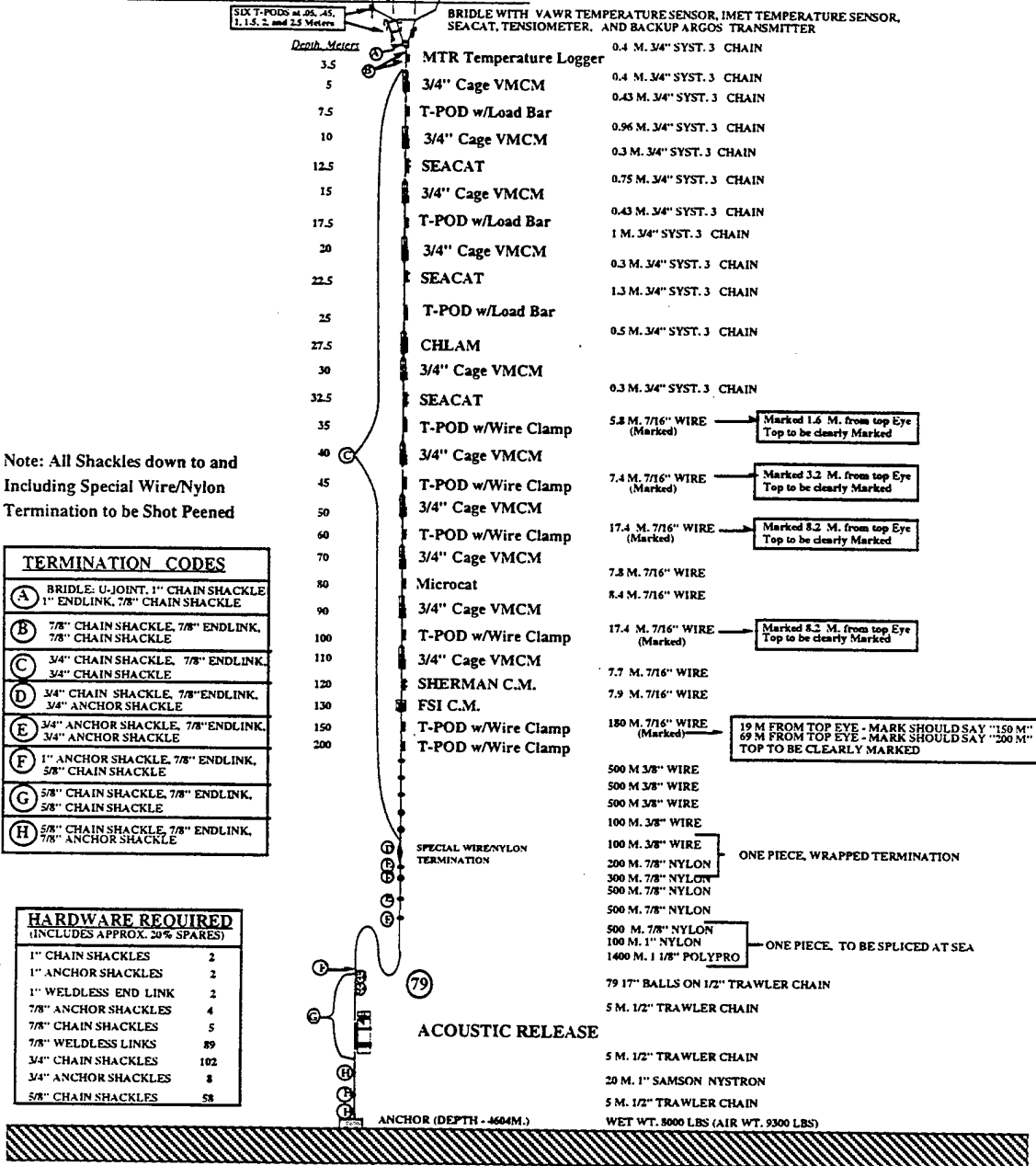

Note: All Shackles down to and
Including Special Wire/Nylon
Termination to be Shot Peened

TERMINATION CODES	
(A)	BRIDLE: U-JOINT, 1" CHAIN SHACKLE 1" ENDLINK, 7/8" CHAIN SHACKLE
(B)	7/8" CHAIN SHACKLE, 7/8" ENDLINK, 7/8" CHAIN SHACKLE
(C)	3/4" CHAIN SHACKLE, 7/8" ENDLINK, 3/4" CHAIN SHACKLE
(D)	3/4" CHAIN SHACKLE, 7/8" ENDLINK, 3/4" ANCHOR SHACKLE
(E)	3/4" ANCHOR SHACKLE, 7/8" ENDLINK, 3/4" ANCHOR SHACKLE
(F)	1" ANCHOR SHACKLE, 7/8" ENDLINK, 5/8" CHAIN SHACKLE
(G)	5/8" CHAIN SHACKLE, 7/8" ENDLINK, 5/8" CHAIN SHACKLE
(H)	5/8" CHAIN SHACKLE, 7/8" ENDLINK, 7/8" ANCHOR SHACKLE

HARDWARE REQUIRED (INCLUDES APPROX. 20% SPARES)	
1" CHAIN SHACKLES	2
1" ANCHOR SHACKLES	2
1" WELDLESS END LINK	2
7/8" ANCHOR SHACKLES	4
7/8" CHAIN SHACKLES	5
7/8" WELDLESS LINKS	89
3/4" CHAIN SHACKLES	102
3/4" ANCHOR SHACKLES	8
5/8" CHAIN SHACKLES	58

PACS I MOORING, 3° SOUTH

G. TUPPER
OCT 2, 1996
Rev 1 - 9 Oct 96
Rev 2 - 15 Oct 96
Rev 3 - 28 Nov 96 RT
Rev 4 - 22 Jan 97
2 Oct 97 RT

Figure 4: WHOI PACS 1 South mooring schematic

MAXIMUM DIAMETER OF BUOY
WATCH CIRCLE = 4.0 N. MILES

3 meter Discus Buoy with, VAWR and IMET,
Both with Argos Telemetry, Stand-Alone Rel.
Hum/Air Temp., Stand-Alone Precip., and
Floating Sea Surface Temperature Sensor

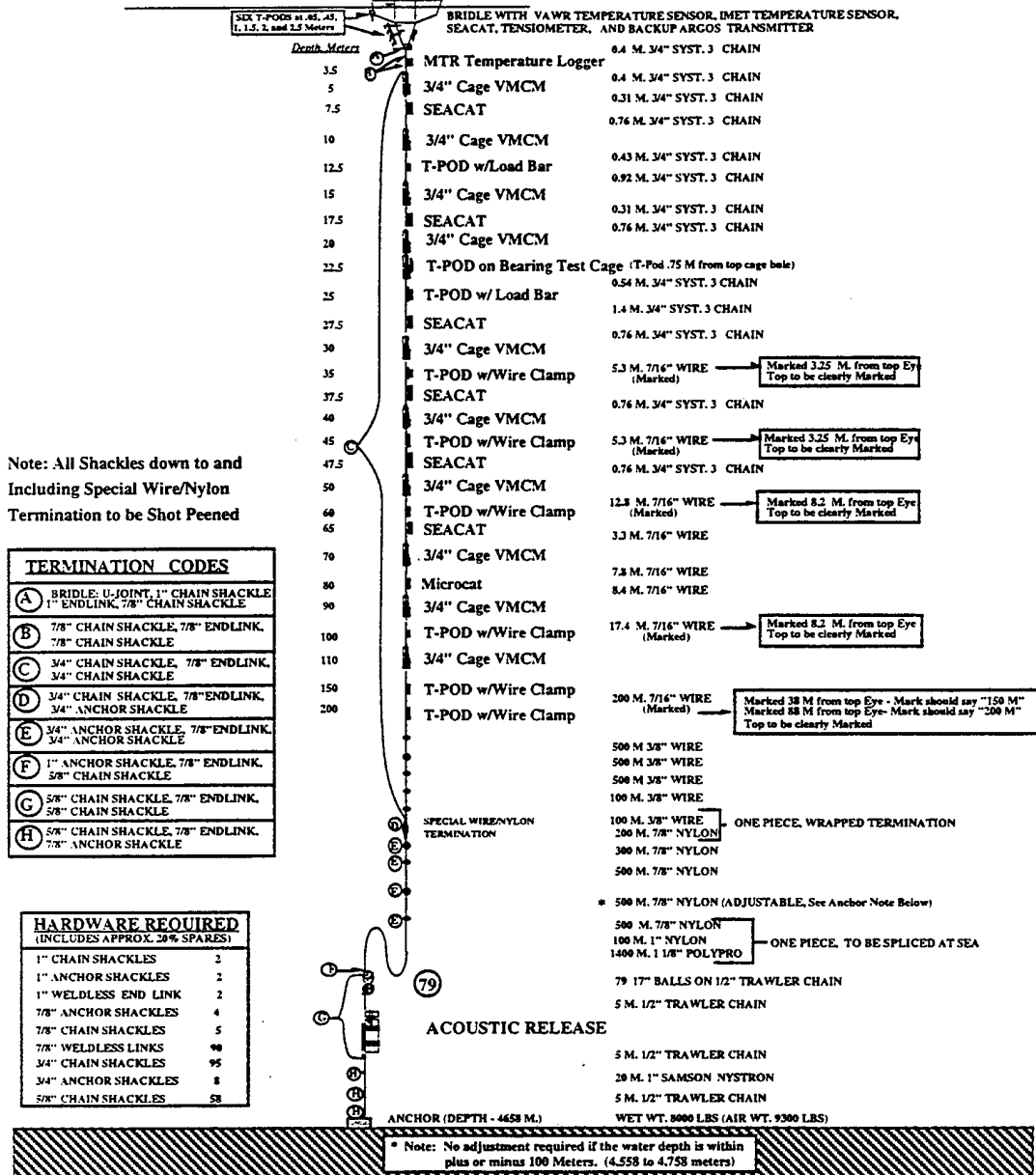

Note: All Shackles down to and including Special Wire/Nylon Termination to be Shot Peened

TERMINATION CODES	
(A)	BRIDLE, U-JOINT, 1" CHAIN SHACKLE 1" ENDLINK, 7/8" CHAIN SHACKLE
(B)	7/8" CHAIN SHACKLE, 7/8" ENDLINK, 7/8" CHAIN SHACKLE
(C)	3/4" CHAIN SHACKLE, 7/8" ENDLINK, 3/4" CHAIN SHACKLE
(D)	3/4" CHAIN SHACKLE, 7/8" ENDLINK, 3/4" ANCHOR SHACKLE
(E)	3/4" ANCHOR SHACKLE, 7/8" ENDLINK, 3/4" ANCHOR SHACKLE
(F)	1" ANCHOR SHACKLE, 7/8" ENDLINK, 3/8" CHAIN SHACKLE
(G)	5/8" CHAIN SHACKLE, 7/8" ENDLINK, 5/8" CHAIN SHACKLE
(H)	5/8" CHAIN SHACKLE, 7/8" ENDLINK, 7/8" ANCHOR SHACKLE

HARDWARE REQUIRED (INCLUDES APPROX. 20% SPARES)	
1" CHAIN SHACKLES	2
1" ANCHOR SHACKLES	2
1" WELDLESS END LINK	2
7/8" ANCHOR SHACKLES	4
7/8" CHAIN SHACKLES	5
7/8" WELDLESS LINKS	90
3/4" CHAIN SHACKLES	95
3/4" ANCHOR SHACKLES	8
5/8" CHAIN SHACKLES	58

PACS 2 MOORING, 10° NORTH

G. TUPPER
OCT 2, 1996
Rev 1 - 9 Oct 96
Rev 2 - 15 Oct 96
Rev 3 - 26 Nov 96 RT
Rev 4 - 22 Jan 97
Rev 5 - 3 Aug 97 RT
Rev 6 - 8 Sept 97 RT
Rev 7 - 17 Oct 97

Figure 5: WHOI PACS 2 North mooring schematic

MAXIMUM DIAMETER OF BUOY
WATCH CIRCLE = 4.1 N. MILES

3 meter Discus Buoy with, VAWR and IMET,
Both with Argos Telemetry, Stand-Alone Rel.
Hum./Air Temp., Stand-Alone Precip, and
Floating Sea Surface Temperature Sensor

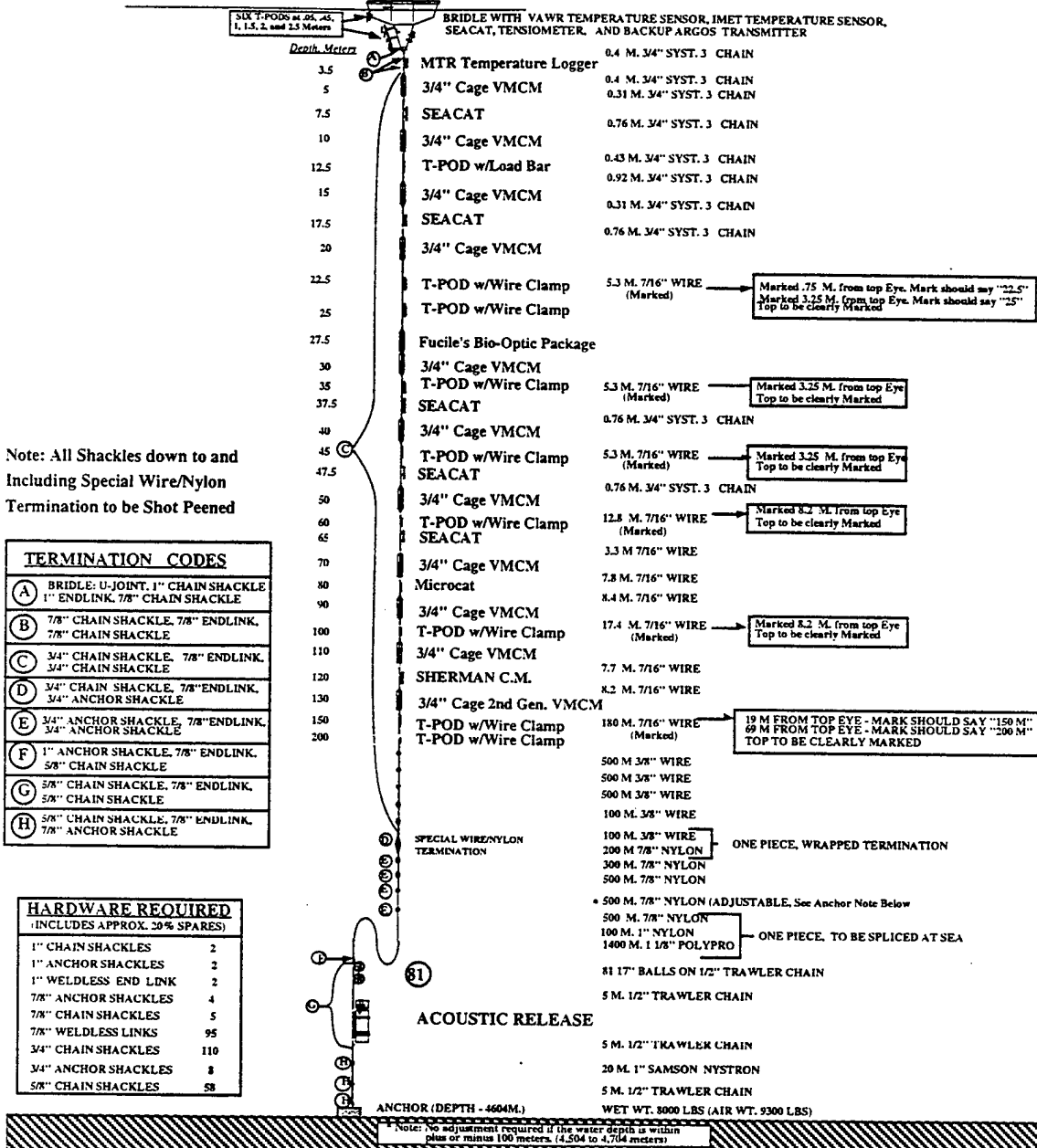

Note: All Shackles down to and
Including Special Wire/Nylon
Termination to be Shot Peened

TERMINATION CODES	
(A)	BRIDLE: U-JOINT, 1" CHAIN SHACKLE 1" ENDLINK, 7/8" CHAIN SHACKLE
(B)	7/8" CHAIN SHACKLE, 7/8" ENDLINK, 7/8" CHAIN SHACKLE
(C)	3/4" CHAIN SHACKLE, 7/8" ENDLINK, 3/4" CHAIN SHACKLE
(D)	3/4" CHAIN SHACKLE, 7/8" ENDLINK, 3/4" ANCHOR SHACKLE
(E)	3/4" ANCHOR SHACKLE, 7/8" ENDLINK, 3/4" ANCHOR SHACKLE
(F)	1" ANCHOR SHACKLE, 7/8" ENDLINK, 5/8" CHAIN SHACKLE
(G)	5/8" CHAIN SHACKLE, 7/8" ENDLINK, 5/8" CHAIN SHACKLE
(H)	5/8" CHAIN SHACKLE, 7/8" ENDLINK, 7/8" ANCHOR SHACKLE

HARDWARE REQUIRED (INCLUDES APPROX. 20% SPARES)	
1" CHAIN SHACKLES	2
1" ANCHOR SHACKLES	2
1" WELDLESS END LINK	2
7/8" ANCHOR SHACKLES	4
7/8" CHAIN SHACKLES	5
7/8" WELDLESS LINKS	95
3/4" CHAIN SHACKLES	110
3/4" ANCHOR SHACKLES	8
5/8" CHAIN SHACKLES	58

G. TUPPER
OCT 2, 1996
Rev 1 - 9 Oct 96
Rev 2 - 15 Oct 96
Rev 3 - 26 Nov 96 RT
Rev 4 - 25 Jan 97
Rev 5 - 28 July 97 RT
Rev 6 - 4 Sept 97 RT
Rev 7 - 20 Oct 97
Rev 8 - 2 Dec 97 RT

PACS 2 MOORING, 3° SOUTH

Figure 6: WHOI PACS 2 South mooring schematic

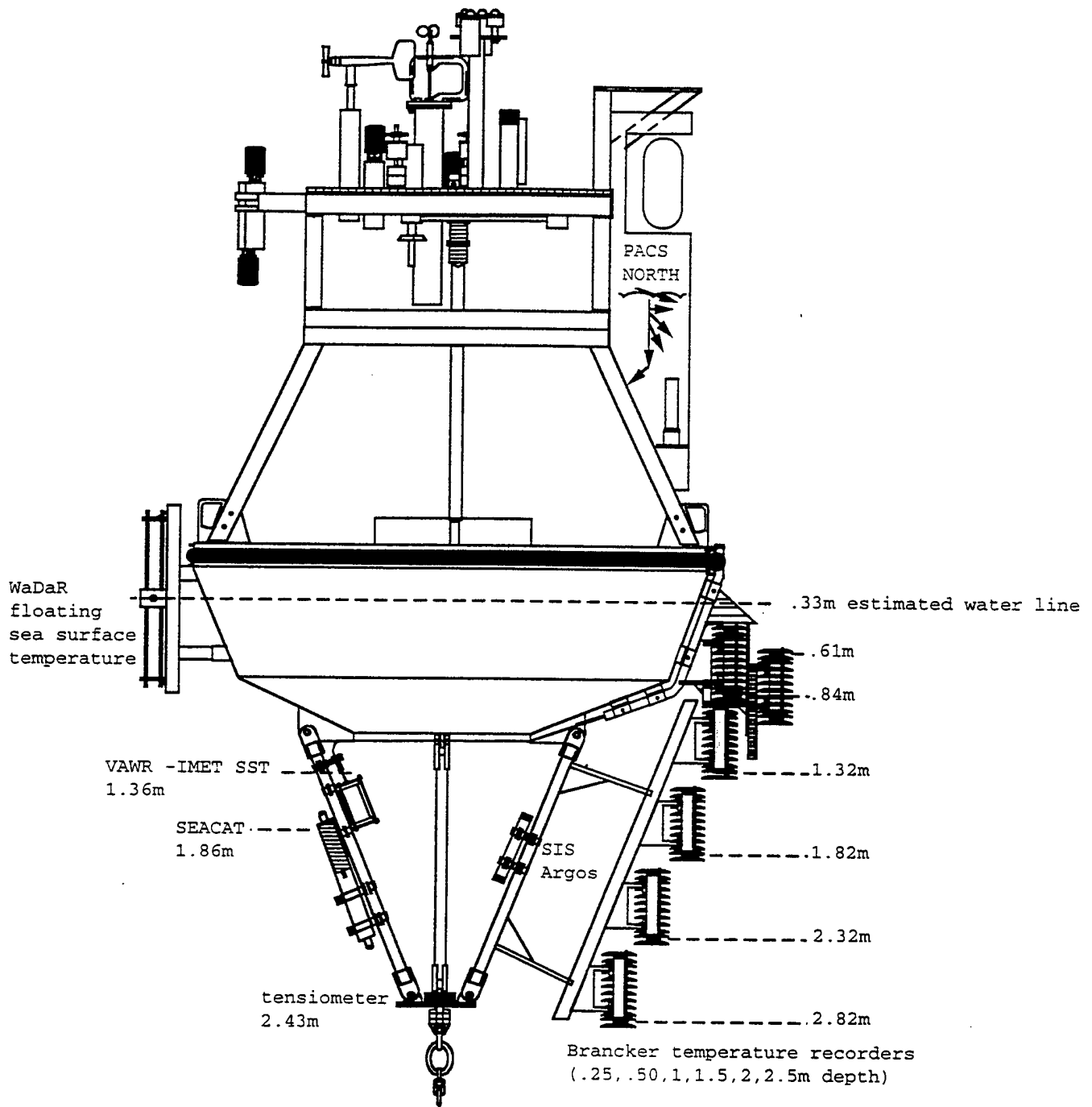

Figure 7: PACS 1 North disc buoy with tower and bridle instrumentation.

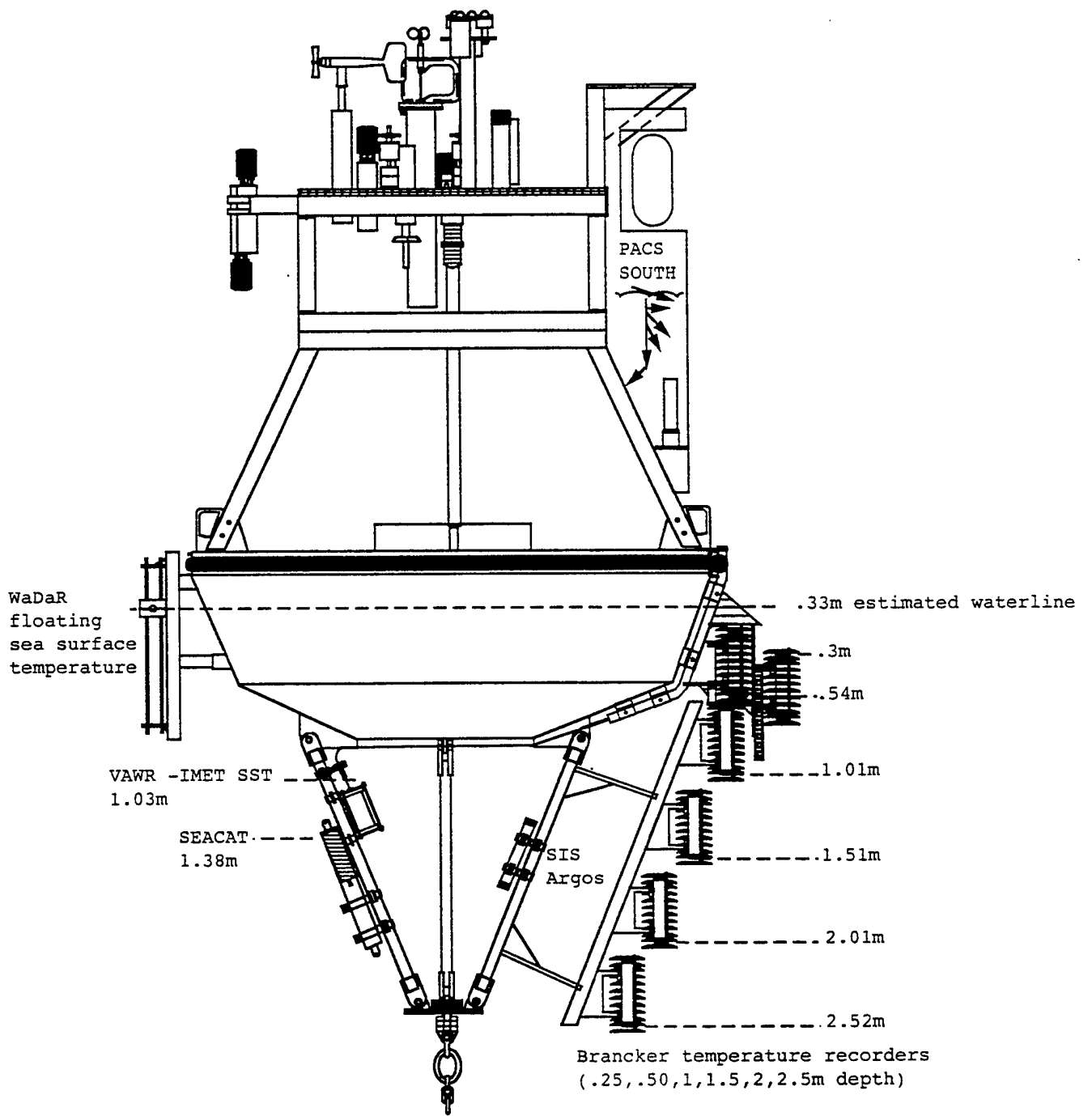

Figure 8: PACS 1 South discus buoy with tower and bridle instrumentation.

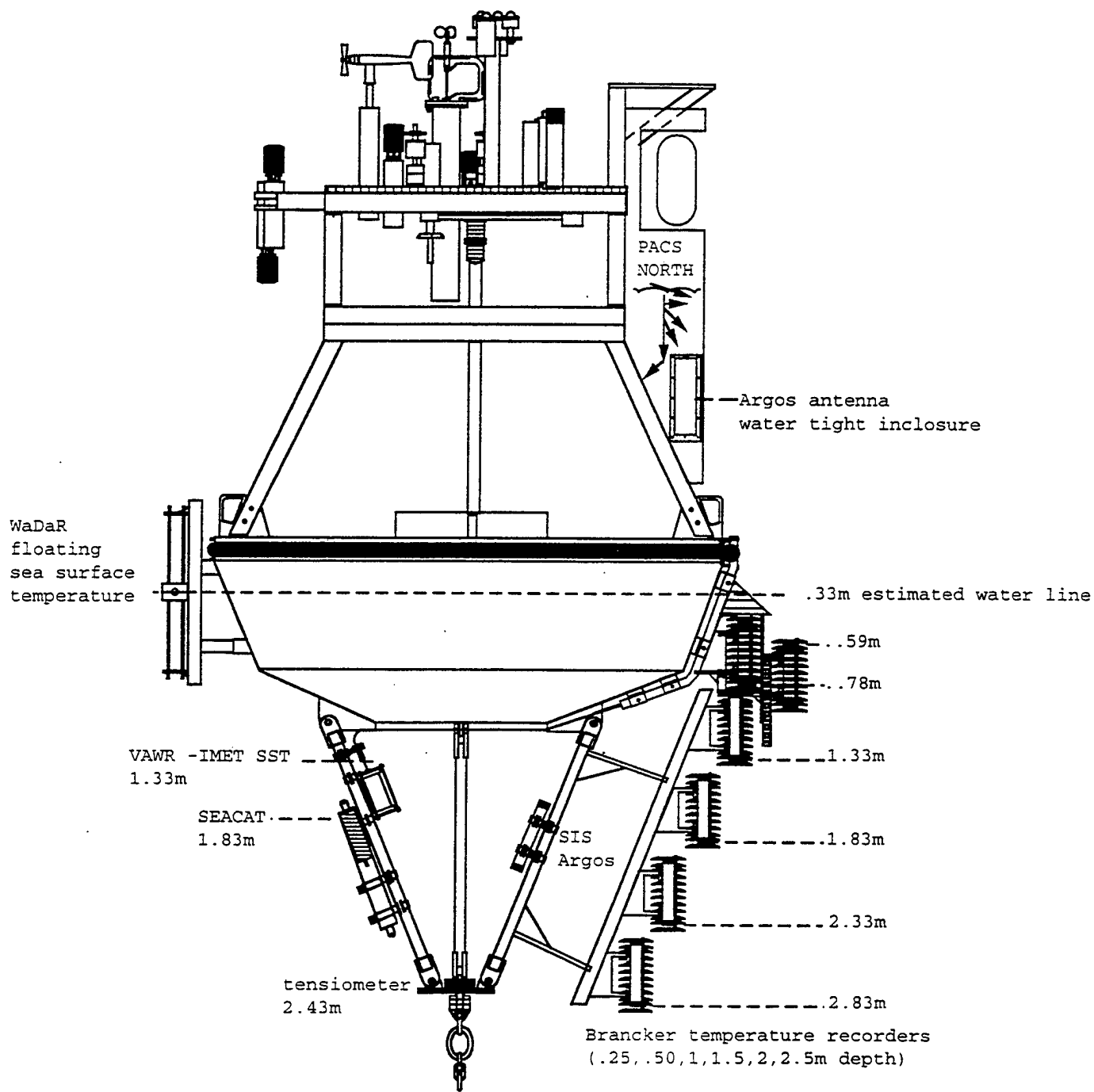

Figure 9: PACS 2 North discus buoy with tower and bridle instrumentation.

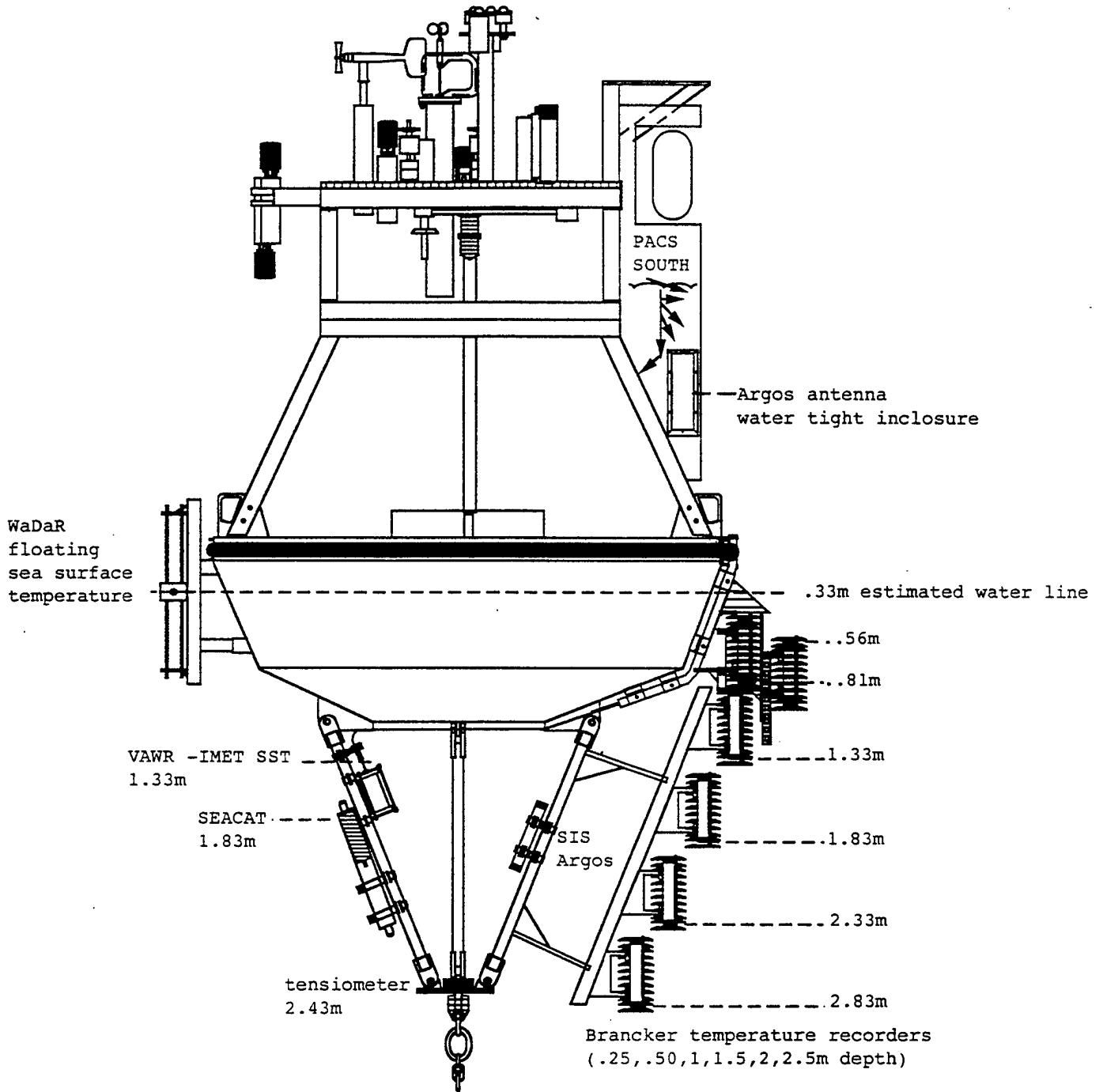

Figure 10: PACS 2 South discus buoy with tower and bridle instrumentation.

Shackles used on the WHOI moorings were shot peened to improve their fatigue endurance. Weldless endlinks were used based on their superior performance during fatigue testing. Vector measuring current meter (VMCM) cages were gusseted and welds redone to meet new specifications established during Arabian Sea cyclic fatigue testing. More information about the design effort and cyclic fatigue tests can be found in Trask, *et al.*, 1995; and Trask and Weller, 1996.

The PACS 1 North and South moorings each had two suites of meteorological sensors, 10 VMCMs, 17 temperature recorders, one of which was deployed in a small surface-following float, and five conductivity/temperature recorders. In addition, the PACS 1 North mooring had an acoustic rain gauge at a depth of 29 meters, and a mooring tension and buoy acceleration recorder. Additional instruments on the PACS 1 South mooring included: a CHLorophyll Absorption Meter (CHLAM) at 27.5 meters; a Sherman acoustic doppler current meter at 120 meters; and a Falmouth Scientific, Inc., 3D acoustic current meter at 130 meters.

The PACS 1 South instrumentation appeared in reasonably good condition at the time of recovery. The VMCMs had only minimal fouling in the form of slime and a few gooseneck barnacles. Some gooseneck barnacles that grew on either the propeller sensors or the supporting sting interfered with the free spinning of the propellers but not to such a degree that they prevented the propellers from spinning. In contrast the upper VMCMs on the PACS 1 North mooring were heavily fouled with gooseneck barnacles. The pressure cases of the upper VMCMs were encased with gooseneck barnacles to such a degree that the instrument case was not visible. The antifouling coatings used on the propeller assemblies definitely reduced the growth of barnacles; however, they still managed to grow on both the propellers and supporting sting. The barnacles interfered with the free spinning of propellers, but the propellers were able to spin.

The PACS 1 North mooring had another type of fouling, that caused by fishing net. Based on preliminary data records it appears that the fishing net became fouled with the mooring on or about October 14, 1997. Two VMCMs at 20 meters and 50 meters depth were completely fouled by the net. One SEACAT tension rod at 22.5 meters depth was wrapped in net and the instrument missing. The external communications connector on another SEACAT (at 32.5 meters depth) was broken off which resulted in a flooded instrument. The temperature pod at 25 meters was pulled upward along the wire until it met the wire termination. The acoustic rain gauge at 29 meters sustained some damage to the hydrophone protective cage. It appears that attempts were made to pull the net away from the mooring which resulted in instrument damage and loss.

The PACS 2 North buoy sustained other damage as well. Upon recovery the VAWR wind direction vane was missing, the vane cage was broken and one of the cups on the three-cup anemometer was missing. The VAWR relative humidity bracket was bent, as was the multiplate shield on the IMET relative humidity module. Traces of blue paint were found on the plates of the IMET relative humidity shield. A stand-alone precipitation sensor that was added to the buoy in August 1997 by the R/V *Ron Brown* was recovered with the funnel portion of the module missing. It should be noted that the damage described here did not occur during recovery of the buoy but at some time while the buoy was on station. The data from the VAWR indicates that the wind direction vane was lost on September 23, 1997. The floating sea-surface temperature bracket, which has three guide rods, was recovered with one of the rods bent. Unfortunately the temperature sensor was out of the water at the time the rod became bent; and, therefore, spent the remainder of the deployment in that position. One other interesting observation is that a 1/4-inch diameter line was found tied off to one of the buoy deck bales.

The instrument well of the PACS 1 North buoy was approximately two-thirds full of water at the time of recovery. The water, however, did not affect the performance of the instrumentation in the well while the buoy was moored on station. It became a problem following recovery when the buoy with its attached bridle was sitting on the deck of the ship at an angle. In that orientation the water seeped into the IMET battery junction box, resulting in the failure of the IMET system.

Each of the PACS 2 North and South moorings had two suites of meteorological instruments, 10 VMCs, 17 temperature recorders with one mounted in a surface following float, and a mooring tension and buoy acceleration recorder. The PACS 2 moorings were outfitted with more conductivity/temperature instruments than the PACS 1 moorings. Each PACS 2 mooring had eight conductivity/temperature sensors. The PACS 2 South mooring had a bio-optical instrument at 27.5 meters which, along with other variables, made measurements of conductivity and temperature. The conductivity measurement made by the bio-optical instrument is one of eight made on the South mooring. A Sherman acoustic doppler current meter was also deployed at 120 meters on the PACS 2 South mooring.

Each instrument used on the WHOI moorings was given a pre-cruise electronics check-out prior to being loaded onto the ship. Preparations for PACS 1 took place in Cal-lao, Peru. Pre-cruise preparations for the second deployment were conducted at the Uni-versity of Hawaii Marine Center located on Snug Harbor, Honolulu, Hawaii.

All of the instrumentation used on the WHOI moorings had some type of pre-deployment time mark applied. The meteorological systems had their short-wave radiation sensors black bagged for two record cycles. The VMCs had their rotors spun. All of the temperature recorders were put in an ice bath for at least two record intervals. The times associated with these temperature spikes are recorded in each instrument's respective log book and appear in Appendix 3. The time marks can be used to verify the accuracy of the instrument's clock in data processing. Appendix 4 has a complete listing of all WHOI in-strumentation deployed during PACS 1 and 2. For each instrument type the listing shows the instrument serial number, the mooring on which it was deployed and the corresponding depth.

Details about each type of instrument are provided below beginning with the mete-orological instrumentation and then followed by the sub-surface instrumentation. Specific information about the instrumentation deployed during PACS 1 can be found in Way *et al.*, 1998.

1. Meteorological Instrumentation

The WHOI discus buoys were outfitted with two separate meteorological packages. One system was a Vector Averaging Wind Recorder (VAWR) which logged and telemetered data from eight meteorological sensors. The second meteorological data recording system called IMET (Improved METeorological measurements) logged data from nine meteorological sensors, and this data was also telemetered. On the PACS 1 deployment both buoys had a stand-alone, internally recording instrument that measured relative humidity and air temperature. In addition to the VAWR and IMET systems deployed on the PACS 2 buoys, there was also a stand-alone, internally recording instrument that measured precipitation as well as another that measured both relative humidity and air temperature. The relative humidity instrument is an improved version of the IMET relative humidity module in that it was self-powered and recorded its data internally. It was part of a family of in-struments called VOS IMET which have been in use on Volunteer Operating Ships (VOS).

Figures 11 and 12 show a plan view layout of the meteorological instrumentation mounted on the PACS 1 and 2 WHOI discus buoys respectively. Tables 3 and 4 list the buoy-mounted instrumentation on the PACS 1 WHOI North and South buoys. The information listed includes sensor identification and sensor height with respect to the water line. Tables 5 and 6 provide the same information for the PACS 2 North and South buoys. The height of all buoy-mounted instrumentation is initially referenced to the buoy deck since the actual water line is never known until after deployment. At the time of recovery, if not sooner, the location of the water line is measured with respect to the buoy deck. In the case of the PACS 1 buoys the water line was measured to be .33 meters below the deck of the buoy. Since instrument loading and environmental conditions are expected to be similar for the PACS 2 deployment, the location of the water line is estimated to also be .33 meters below the deck. This will be checked when the moorings are recovered in the fall of 1998.

A wind direction sensor comparison test was conducted for both the PACS 2 South and North buoys in Woods Hole and at the University of Hawaii Marine Center. This was done to confirm that the compasses of each VAWR and IMET were in proper working order. The data from the direction comparison tests can be found in Appendix 5. The meteorological instruments are described in detail below.

a. Vector Averaging Wind Recorder

One of the two meteorological units mounted on the WHOI three-meter diameter discus buoy was a Vector Averaging Wind Recorder (VAWR), which is configured to measure wind speed, wind direction, short-wave radiation, long-wave radiation, relative humidity, barometric pressure, air temperature, and sea surface temperature. Recording on a digital cassette, the VAWR wrote data to tape every 15.0 minutes. Table 7 shows the type of sensors used for the meteorological measurements and the sampling scheme. Data from the VAWR were telemetered via satellite back to WHOI through Service Argos. The VAWR Argos transmitter has three PTT ID numbers for data transmission, one of which is used for obtaining position information. The standard temperature range typically used in the VAWR is 0 to 30°C. This range for the PACS deployments was modified to be 0° to 35°C due to the expected high temperatures. The VAWR sea surface temperature (SST) sensor was mounted on the bridle at a depth of approximately one meter. A continuous length of cable was run from the VAWR to the buoy deck and then down to the bridle mounted SST sensor via an external aluminum pipe mounted on the side of the buoy to protect the cable. This method eliminated the need for multiple bulkhead connectors which can affect the temperature reading. Details of the VAWR configuration can be found in Trask *et al.*, 1995.

b. Improved METeorological System

The Improved METeorological (IMET) system for the PACS WHOI discus buoys consisted of nine IMET sensor modules and one Argos transmitter module to telemeter data via satellite back to WHOI through Service Argos. Table 8 details IMET sensor specifications. The following IMET modules types were deployed on the PACS discus buoys:

1. relative humidity with temperature
2. barometric pressure

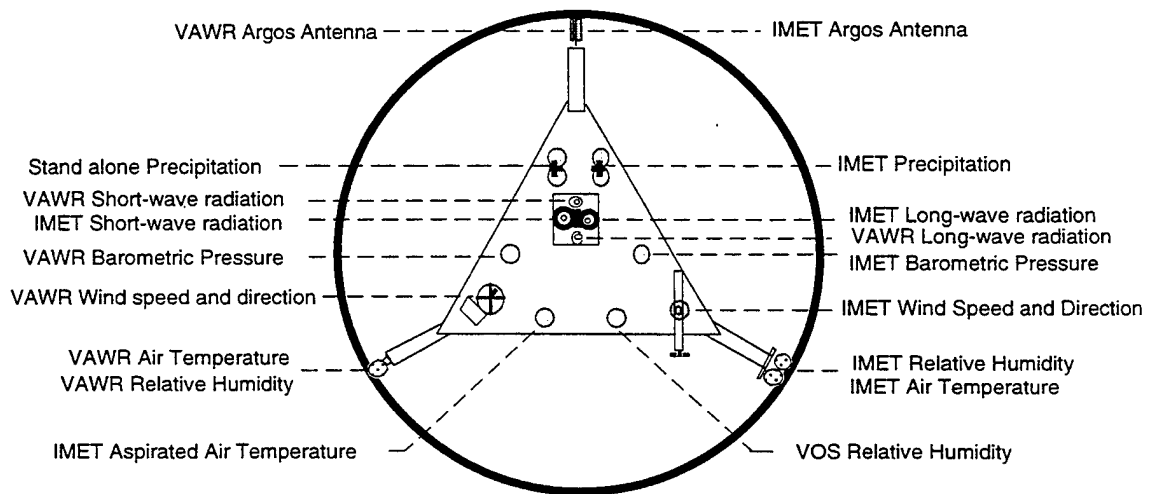
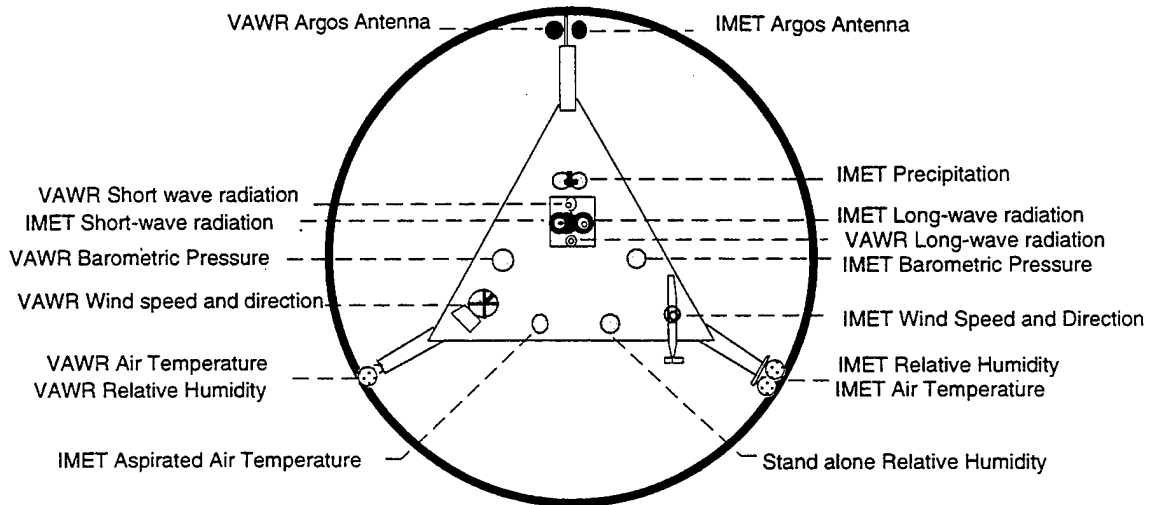

Figure 11: (top) PACS 1 meteorological instrument placement on buoy tower top.
Figure 12: (bottom) PACS 2 meteorological instrument placement on buoy tower top.

Table 3: PACS 1 North discus buoy-mounted sensors and corresponding elevations.

Parameter	Sensor ID	Elevation relative to buoy deck [meters]	Elevation relative to water line [meters]	Measurement Location
IMET	Logger 295			
Wind speed	WND 111	2.90	3.26	Prop Axis
Wind direction	WND 111	2.90	3.26	Prop Axis
Air temperature	TMP 105	1.63	1.99	End of Probe
Aspirated air temperature	TMP 101	1.85	2.21	End of Probe
Relative humidity	HRH 107	2.37	2.73	Tip of Sensor
Barometric pressure	BPR 107	2.36	2.72	Center of port
Precipitation	PRC 102	2.73	3.09	Top of funnel
Long-wave radiation	LWR 006	3.05	3.41	Base of dome
Short-wave radiation	SWR 111	3.05	3.41	Base of dome
Sea temperature	SST 109	-1.36	-1.00	End of Probe
VAWR	V722WR			
Wind speed	V722WR	2.97	3.33	Center of Cups
Wind direction	V722WR			
Air temperature	5815	1.80	2.16	End of Probe
Relative humidity	V-028-001	2.17	2.53	Tip of Sensor
Barometric pressure	44141	2.38	2.74	Center of port
Long-wave radiation	28459	3.05	3.41	Base of dome
Short-wave radiation	26257	3.05	3.41	
Sea temperature	5005	-1.36	-1.00	End of probe
Stand-alone relative humidity	008	2.38	2.74	
SEACAT conductivity/temp	994	-1.86	-1.50	At temperature probe
Floating sea surface temp	WADAR 275	surface	0	
Temperature recorder	3263	-0.61	-0.25	Thermistor end
Temperature recorder	4491	-0.84	-0.48	Thermistor end
Temperature recorder	4483	-1.32	-0.96	Thermistor end
Temperature recorder	3258	-1.82	-1.46	Thermistor end
Temperature recorder	3838	-2.32	-1.96	Thermistor end
Temperature recorder	3704	-2.82	-2.46	Thermistor end
Tension cell	94033	Base of bridle		
Distance between buoy deck and water line was .36 meters				

Table 4: PACS 1 South discus buoy-mounted sensors and corresponding elevations.

Parameter	Sensor ID	Elevation relative to buoy deck [meters]	Elevation relative to water line [meters]	Measurement Location
IMET	Logger 143			
Wind speed	WND 105	2.89	3.22	Prop Axis
Wind direction	WND 105	2.89	3.22	Prop Axis
Air temperature	TMP 104	1.72	2.05	End of probe
Aspirated air temp	TMP 106	1.86	2.19	End of probe
Relative humidity	HRH 110	2.31	2.64	Tip of sensor
Barometric pressure	BPR 110	2.37	2.70	Center of port
Precipitation	PRC 109	2.74	3.07	Top of funnel
Long-wave radiation	LWR 104	3.05	3.38	Base of dome
Short-wave radiation	SWR 109	3.05	3.38	Base of dome
Sea temperature	SST 005	-1.36	-1.03	End of Probe
VAWR	V707WR			
Wind speed	V707WR	2.97	3.30	Center of Cups
Wind direction	V707WR			
Air temperature	5814	1.77	2.10	End of probe
Relative humidity	V-021-001	2.17	2.50	Tip of sensor
Barometric Pressure	53235	2.39	2.72	Center of port
Long-wave radiation	27957	3.05	3.38	Base of dome
Short-wave radiation	28298	3.05	3.38	Base of dome
Sea temperature	5510	-1.36	-1.03	End of probe
Stand-alone relative humidity	006	2.41	2.74	
SEACAT conductivity/temp	143	-1.71	-1.38	At temperature probe
Floating sea surface temp	WaDaR 274	surface	0	
Temperature recorder	3835	-0.63	-0.30	Thermistor end
Temperature recorder	3699	-0.87	-0.54	Thermistor end
Temperature recorder	3701	-1.34	-1.01	Thermistor end
Temperature recorder	4492	-1.84	-1.51	Thermistor end
Temperature recorder	4489	-2.34	-2.01	Thermistor end
Temperature recorder	3764	-2.85	-2.52	Thermistor end
Tension cell	dummy cell	Base of bridle		
Distance between buoy deck and water line was .33 meters				

Table 5: PACS 2 North discus buoy-mounted sensors and corresponding elevations.

Parameter	Sensor ID	Elevation relative to buoy deck [meters]	Measurement location
IMET	Logger 291		
Wind speed	WND 113	2.95	Prop Axis
Wind direction	WND 113	2.95	Prop Axis
Air temperature	TMP 110	1.74	Mid shield
Aspirated air temp	TMP 102	1.85	Tip of Probe
Relative humidity	HRH 111	2.2	Mid shield
Barometric pressure	BPR 105	2.39	Center of port
Precipitation	PRC 108	2.74	Top of funnel
Long-wave radiation	LWR 101 (28908)	3.06	Base of dome
Short-wave radiation	SWR 002	3.06	Base of dome
Sea temperature	SST 106	-1.33	End of Probe
VAWR	V721WR		
Wind speed	V721WR	2.97	Center of Cups
Wind direction	V721WR	2.71	Mid vane
Air temperature	5824	1.79	Mid Shield
Relative humidity	V-022-01	2.14	Mid Shield
Barometric pressure	55796	2.39	Center of port
Long-wave radiation	21787	3.06	Base of dome
Short-wave radiation	24103	3.06	Base of dome
Sea temperature	5523	-1.33	End of probe
Stand-alone precipitation	004	2.73	Top of funnel
ASIMET relative humidity	HRH 204	2.47	Mid Shield
Floating sea surface temperature	WaDaR 272	0.0	
SEACAT conductivity/temp	2322	-1.83	At temperature probe
Temperature recorder	3837	-0.59	Thermistor end
Temperature recorder	3833	-0.78	Thermistor end
Temperature recorder	3308	-1.33	Thermistor end
Temperature recorder	3291	-1.83	Thermistor end
Temperature recorder	3296	-2.33	Thermistor end
Temperature recorder	4402	-2.83	Thermistor end
Tension cell	94034	Base of bridle	
Nominal distace between buoy deck and water line is .33 meters			

Table 6: PACS 2 South discus buoy-mounted sensors and corresponding elevations.

Parameter	Sensor ID	Elevation relative to buoy deck [meters]	Measurement Location
IMET			
Wind speed	WND 108	2.96	Prop Axis
Wind direction	WND 108	2.96	Prop Axis
Air temperature	TMP 108	1.76	Mid shield
Aspirated air temp	TMP005	1.76	Tip of Probe
Relative humidity	HRH 108 (26356)	2.19	Mid shield
Barometric pressure	BPR 006	2.38	Center of port
Precipitation	PRC 004	2.74	Top of funnel
Long-wave radiation	LWR 103	3.06	Base of dome
Short-wave radiation	SWR 102	3.06	Base of dome
Sea temperature	SST 003	-1.33	End of Probe
VAWR			
Wind speed	V706WR	2.97	Center of Cups
Wind direction	V706WR	2.71	Mid vane
Air temperature	5817	1.79	Mid Shield
Relative humidity	V-036-01	2.15	Mid Shield
Barometric pressure	45918	2.38	Center of port
Long-wave radiation	28872	3.06	Base of dome
Short-wave radiation	28416	3.06	Base of dome
Sea temperature	5539	-1.33	End of probe
Stand-alone precipitation	003	2.72	Top of funnel
ASIMET relative humidity	HRH 206	2.49	Mid Shield
Floating sea surface temperature	WaDaR 273	0.0	
SEACAT conductivity/temperature	1882	-1.83	At temperature probe
Temperature recorder	4228	-0.56	Thermistor end
Temperature recorder	3274	-0.81	Thermistor end
Temperature recorder	3271	-1.33	Thermistor end
Temperature recorder	4486	-1.83	Thermistor end
Temperature recorder	3830	-2.33	Thermistor end
Temperature recorder	3834	-2.83	Thermistor end
Tension cell	43390		
Nominal distance between buoy deck and water line is .33 meters			

Table 7: VAWR sensor specifications

Parameter	Sensor Type	Nominal Accuracy	Comments
Wind speed	R. M. Young 3-cup 3-cup Anemometer	+5% +/-2%	Vector - averaged Note 1
Wind direction	Integral vane w/vane follower WHO/EG&G	+/- 1 bit 5.6°	Vector- averaged
Insolation	Pyranometer Eppley 8-48	+/-3%	Averaged of reading
Long-wave Radiation Thermopile Body temp. Dome temp.	Pyrgeometer Eppley PIR PIR 10K @ 25° C 10K @ 25° C	+/- 10%	Averaged Note 2 Note 3
Relative humidity	Variable Dielectric Conductor Vaisala Humicap 0062HM	+/- 2% RH	3.515 sec. Sample Note 4
Barometric pressure	Quartz crystal Digiquartz Paroscientific Model 215, 216	+/- 0.2 mbars wind < 20 m/s	2.636 sec. Sample Note 4
Sea temperature	Thermistor Thermometrics 4K @ 25°C	+/- .005°C	Note 5
Air temperature	Thermistor Yellow Springs #44034 5K @ 25°C	+/- 0.2°C wind > 5 m/s	Note 6

Notes:

1. Over estimation of wind speed is characteristic of cup anemometers
2. LWR body temperature is measured during the third quarter of the recording interval for one quarter of the record time. Error associated with solar heating is not included in accuracy.
3. LWR dome temperature is measured during the fourth quarter of the recording interval, for one quarter of the record time
4. Relative humidity and barometric pressure are burst samples taken in the middle of the recording interval.
5. Sea temperature is measured during the first quarter of the recording interval, for one quarter of the record time.
6. Air temperature is measured during the second quarter of the recording interval, for one quarter of the record time. Error associated with solar heating is not included in accuracy.

Table 8: IMET sensor specifications

<u>Parameter</u>	<u>Sensor</u>	<u>Nominal Accuracy</u>
Air temperature (Static Shield)	Platinum Resistance Thermometer	+/- .25°C
Aspirated Air Temperature	Platinum Resistance Thermometer	+/- .10°C
Sea temperature	Platinum Resistance Thermometer	+/- .005°C
Relative humidity	Rotronic MP-100F	+/- 3%
Barometric pressure	Quartz crystal AIR DB-1A	+/- .5 mbar
Wind speed and Wind direction	R. M. Young model 5103 Wind Monitor	-3% (speed) +/- 1.5° (dir)
Short-wave radiation	Temperature Compensated Thermopile Eppley PSP	+/- 3%
Long-wave radiation	Pyrometer Eppley PIR	+/- 10%
Precipitation	R. M. Young model 50201 Self-siphoning rain gauge	+/- 10%

Notes:

The logger polls all IMET modules at one-minute intervals (takes several seconds) and then goes to low power sleep mode for the rest of the minute. Data is written to disk once per hour. The logger also monitors main battery and aspirated temperature battery voltage.

The air temperature, sea-surface temperature, barometric pressure, relative humidity, long-wave radiation and precipitation modules take a sample once per minute and then go to low power sleep mode for the rest of the minute.

The short-wave radiation module takes a sample every ten seconds and produces a running one minute average of the six most recent samples. It goes to low power sleep mode between ten second samples.

The vane on the wind module is sampled at one-second intervals and averaged over 15 seconds. The compass is sampled every 15 seconds and the wind speed is averaged every 15 seconds. East and north current components are computed every 15 seconds.

Once a minute the logger stores an average east and north component that is an average of the most recent four 15 second averages. In addition average speed from four 15 second averages is stored, along with the maximum and minimum speed during the previous minute, average vane computed from four, 15-second averages, and the most recent compass reading.

In addition, an IMET Argos PTT module was set for three IDs and transmits via satellite the most recent six hours of one-hour averages from the IMET modules. At the start of each hour, the previous hour's data is averaged and sent to the PTT, bumping the oldest hour's data out of the data buffer.

3. air temperature (R. M. Young passive shield)
4. air temperature (aspirated shield)
5. sea surface temperature
6. precipitation
7. wind speed and direction
8. short-wave radiation
9. long-wave radiation

All IMET modules for the PACS experiment were modified for lower power consumption so that a non-rechargeable alkaline battery pack could be used in the buoy well.

The data logger for the system is based on an Onset Computer, Corp., model 7 Tattletale computer with hard drive which is also configured and programmed with power conservation in mind. An associated interface board ties the model 7 via individual power and RS-485 communications lines to each of the nine IMET modules including the PTT module.

c. Stand-alone Precipitation Instrument

A self-contained precipitation instrument was mounted on the tower of the PACS 2 discus buoys. This instrument, developed and built by members of the UOP Group, takes a single-point measurement of rainfall at a desired record interval. The sensor used is an R. M. Young, model 050202, self-siphoning rain gauge. This sensor uses a capacitive measurement technique to measure the volume of rain water deposited inside a collection chamber. It automatically empties in about 20 seconds when the chamber is full. The output of the sensor is 0 to 5 Vdc, which represents 0 to 50 mm of rainfall in the gauge. The sensor was sampled every 3.75 minutes during the PACS 2 deployment. The logger is an Onset Computer, Corp., model 4A Tattletale, with expanded memory to 512K. The unit is powered by its own internal battery pack.

During PACS 1 the IMET system on the North buoy began to experience an intermittent Argos telemetry problem. It was unclear as to whether or not the IMET system was working properly. The VAWR mounted on the same buoy provided redundant measurements for all the variables except precipitation. In order to provide some redundancy with regard to the precipitation measurement, arrangements were made with Sandra Yuter (University of Washington) to install a stand-alone precipitation instrument on the North buoy. The sensor was mounted on the North buoy during a cruise of the R/V *Ron Brown* on August 8, 1997.

d. VOS IMET relative humidity with temperature instrument

A VOS IMET relative humidity module was mounted on both the North and South discus buoys deployed during PACS 2. The VOS module is an improved version of the IMET module developed for the World Ocean Circulation Experiment (WOCE) program. VOS modules are self-powered and internally recording. The relative humidity measurement is made with a Rotronic MP-101A sensor. The sensor is packaged in a custom housing, which is more rugged than the standard housing and with high pressure water seals. The humidity temperature probe provides analog outputs of 0 volts to 1.0 volts DC for humidity (1 to 100% rh); and 0 to 1.0 volts DC for temperature (-40° to +60°C). These signals are amplified and converted to digital in the module. One set of measurements are made every minute and calibrated via a fourth order polynomial for rh% and degrees C. The probe is placed inside a standard R. M. Young multi-plate radiation shield.

e. Stand-alone Relative Humidity/Air Temperature Instrument

A self-contained relative humidity and air temperature instrument was mounted on the tower of the PACS 1 discus buoys. This instrument, developed and built by members of the UOP Group, takes a single point measurement of both relative humidity and temperature at a desired record interval. The sensor used is a Rotronics relative humidity sensor, model MP-100. The relative humidity and temperature measurements are made inside a protective Gortex shield. The logger is an Onset Computer, Corp., Model 4A Tattletale, with expanded memory to 512 K. The unit is powered by its own internal battery pack. The instrument record interval was set to 3.75 minutes for the PACS experiment.

2. Sub-Surface Instrumentation

Since the water line is not exactly known until after deployment, the depth of the sub-surface instrumentation, that is mounted directly to the discus buoy bridle, is initially referenced to the buoy deck. At the time of recovery, if not sooner, the location of the water line is measured with respect to the buoy deck. In the case of the PACS 1 buoys the water line was measured to be .33 meters below the deck of the buoy. Since instrument loading and environmental conditions are expected to be similar for the PACS 2 deployment, the location of the water line is estimated to also be .33 meters below the deck. This will be checked when the moorings are recovered in the fall of 1998. Refer to Tables 3, 4, 5, and 6, as well as Figures 7, 8, 9, and 10, for information regarding the depth of buoy-mounted, sub-surface instrumentation. Table 9 lists the PACS 2 sub-surface instrumentation and the depths where they were deployed.

The remainder of this section will describe the sub-surface instrumentation deployed during PACS .

a. Mooring Tension Recorder and Buoy Acceleration

Mooring tension was measured at the base of the rigid bridle on both the PACS 2 South and North buoys. The tension cell on the North buoy was an Omegadyne, Inc., model TH-LB1B(SPL), with a load range of 0 pounds to 10,000 pounds. The tension cell on the South buoy was a D. J. Instruments, model A-16012, also with a load range of 0 pounds to 10,000 pounds. Inside the well of each buoy was a three-axis accelerometer manufactured by Summit Instruments, model #34103A, which measures X, Y, and Z components. The tension and acceleration data were recorded using an Onset Computer, Corp., model 6 Tattletale, with a 40 Mega Byte hard drive attached. Tension and acceleration were sampled every 12 hours beginning at 0000 UTC and 1200 UTC at a 4 HZ rate for a period of 23 minutes. The data from a two-day period were stored in a temporary buffer where it was then written to the disk drive. A time spike was applied to the tension cells by pulling on the bridle bail with an aircraft strap.

b. Sub-surface Argos Transmitter

An NACLS, Inc., Sub-surface Mooring Monitor (SMM) was mounted upside down on the bridle of each discus buoy as a backup recovery aid in the event that the mooring parts close to the buoy and the buoy becomes unstable and flips upside down.

Table 9: PACS 2 Sub-Surface Instrumentation

Depth	WHOI South	WHOI North
Surface	WaDaR-273	WaDaR 272
.25	T-4228	T-3837
.50	T-3274	T-3833
1.0	T-3271	T-3308
1.0	VAWR SST	VAWR SST
1.0	IMET SST 003	IMET SST 106
1.5	T-4486	T-3291
1.5	SEACAT 1882	SEACAT 2322
2.0	T-3830	T-3296
2.5	T-3834	T-4402
3.5	MTR-3242	MTR-3241
5.0	VM-045	VM-017
7.5	SEACAT 1874	SEACAT 1881
10.0	VM-023	VM-044
12.5	T-3763	T-4488
15.0	VM-041	VM-055
17.5	SEACAT 1878	SEACAT 141
20.0	VM-043	VM-010
22.5	T-3506	T-3508
25.0	T-3507	T-4493
27.5	Bio-Optical Pkg	SEACAT 1875
30.0	VM-022	VM-028
35.0	T-3301	T-2535
37.5	SEACAT 1876	SEACAT 1873
40.0	VM-051	VM-027
45.0	T-3831	T-2541
47.5	SEACAT 141	SEACAT 927
50.0	VM-053	M-002
60.0	T-3702	T-2537
65.0	SEACAT 1880	SEACAT 1877
70.0	VM-034	VM-012
80.0	MicroCAT 008	MicroCAT 011
90.0	VM-030	VM-052
100.0	T-3299	T-3701
110.0	VM-040	VM-001
120.0	Sherman CM 001	-----
130.0	VM-201	-----
150.0	T-2533	T-3764
200.0	T-2536	T-3835

Legend

T-####	Brancker Temperature Recorder
SEACAT #####	SEACAT Conductivity and Temperature Recorder
MTR-###	Miniature Temperature Recorder
WaDaR-###	WaDaR Temperature Recorder
MicroCAT-###	MicroCAT Conductivity and Temperature Recorder
VM-###	Vector Measuring Current Meter
Sherman CM ##	SIO acoustic doppler current meter
Bio-Optical Pkg	WHOI bio-optical package

c. SEACAT Conductivity and Temperature Recorders

A total of 13 Sea-Bird, Inc., SEACAT conductivity and temperature recorders were deployed on the PACS 2 surface moorings. The model SBE 16 SEACAT is designed to measure and record temperature and conductivity at high levels of accuracy while deployed in a moored application. Powered by internal batteries, a SEACAT is capable of recording data for periods of a year or more. Data is acquired at intervals set by the user. This interval can be changed at up to nine, pre-determined dates. An internal back-up battery supports memory and the real time clock in the event of failure or exhaustion of the main battery supply. Communication with the SEACAT is over a three-wire RS-232 link. The SEACAT is capable of storing a total of 64,754 samples. A sample rate of 450 seconds was used on the PACS 2 SEACATs. The shallowest SEACAT was mounted directly to the bridle of each of the WHOI discus buoys. The others were mounted on in-line tension bars and deployed at various depths throughout the moorings. Shaft anodes were secured to the in-line tension bars to reduce the potential for electrolysis.

d. MicroCAT Conductivity and Temperature Recorder

The Sea-Bird MicroCAT, model SBE37, is a high-accuracy, conductivity and temperature recorder with internal battery and memory, designed for long term mooring deployments. It includes a standard serial interface to communicate with a PC. Its recorded data are stored in non-volatile FLASH memory. The temperature range of the instrument is -5° to $+35^{\circ}\text{C}$ and the conductivity range is 0 to 6 Siemens/meter. The pressure housing is made of titanium and is rated for 7,000 meters. The conductivity cell is protected from bio-fouling by the placement of anti-foulant cylinders at each end of the conductivity cell tube. The MicroCAT is capable of storing 120,000 samples of temperature, conductivity and time. The sampling interval of the PACS 1 and 2 MicroCAT was 225 seconds. Both the PACS 2 North and South moorings had a MicroCAT placed at 80 meters. The MicroCATs deployed on the PACS 1 and 2 WHOI moorings were purchased with two titanium tabs welded to the pressure case so that the instrument could be bolted to a titanium strength member. The strength member was placed in line on the mooring.

e. Brancker Temperature Recorders

The Brancker temperature recorders are self-recording, single-point temperature loggers. The operating temperature range for this instrument is -2° to 34°C . They have an internal battery and the capability of logging 28,000 samples. A PC is used to communicate with the Brancker via serial cable for instrument set-up and data download. The PACS 1 and 2 Branckers were set to record data every 30 minutes.

A total of 30 Brancker temperature loggers were deployed on the discus moorings, with 15 on each of the buoys. Six were attached to the buoy in a near-surface temperature string, with depths ranging from .25 meters to 2.5 meters. The other nine Branckers on each mooring were dispersed at depths ranging from 7.5 meters to 200 meters.

f. Miniature Temperature Recorder

A Pacific Marine Environmental Lab (PMEL), Miniature Temperature Recorder (MTR) was mounted in line at a depth of 3.5 meters on each of the WHOI moorings. The MTR is a single-point temperature logger. System timing and sampling are controlled by an internal microprocessor. It has an internal 9-volt battery which will power the MTR for periods of greater than one year. Communication is through a serial cable using a PC. The

data, as raw counts, are stored along with system software in battery backed RAM. The MTR has the capability of storing 56,800 samples of temperature. The MTRs were set up for PACS 2 to sample at a rate of 450 seconds.

g. WHOI Vector Measuring Current Meters

The Vector Measuring Current Meter (VMCM) has two orthogonal cosine response propeller sensors that measure the components of horizontal current velocity parallel to the axles of the two propeller sensors. The orientation of the instrument relative to magnetic north is determined by a flux gate compass. East and north components of velocity are computed, averaged and then stored on cassette magnetic tape. Temperature was also recorded using a thermistor mounted in a fast response pod, which was mounted on the top end cap of the VMCM. The VMCMs were set to record data every 7.50 minutes. A total of twenty VMCMs were deployed on the WHOI surface moorings, ten on each mooring, at various depths ranging from 5 meters to 110 meters. All of the WHOI VMCMs had a compass check done at the University of Hawaii Marine Center to verify that the compass was not damaged in transport. A description of how each parameter in the VMCM is sampled appears in Appendix 6

A VMCM with new electronics and the standard orthogonal propeller sensor was deployed at 130 meters on the PACS 2 South mooring. It is the first deployment of a WHOI-upgraded instrument and is intended as a test of the new electronics. Low-power microcontroller technology is the heart of the new VMCM. The primary sub-unit in the VMCM is a vector measuring front end, consisting of rotor and compass hardware interface and a low-power microcontroller to sample these. The instrument deployed in PACS 2 has a Precision Navigation, Inc., TCM2-LP, compass which is linked via RS-232 serial interface to a PIC controller. The TCM2 is a high-performance, low-power electronic compass sensor that outputs compass heading, pitch, and roll readings via electronic interface to the host system. Data are stored on a PCMCIA "flash card" rather than cassette tape, which is standard in the older units. A standard pressure case and load cage were used for the PACS 2 deployment. Data from this instrument will be compared with data from the standard VMCM deployed at 110 meters.

h. WaDaR Temperature Recorder

All of the PACS surface buoys were outfitted with a surface-following temperature logger in order to measure sea-surface temperature. The temperature logger selected for this application was a WaDaR model TL, temperature logger, manufactured by TSKA, Inc. The instrument is self-contained, with batteries, memory and a microprocessor directing operations. A PC is used to communicate with the WaDaR in order to set up the instrument for recording and to download the data. The WaDaR will record up to 65,520 temperature measurements in a single deployment. For the PACS experiment the record rate was set to 450 seconds. The WaDaR has a temperature range of -3° to $+35^{\circ}\text{C}$. The pressure case is made of titanium and is rated for full-ocean depth. The WaDaR was deployed in a molded syntactic foam float designed to follow the ocean surface. The float ran up and down along three stainless guide posts that were attached to the up-wind side (side opposite wind vane) of the discus buoy.

It was noted prior to the recovery of the PACS 1 South buoy that the float was freely moving up and down with each passing wave. The stainless rods were free of any growth, presumably because of the wiping action of the float. The float that was deployed on PACS 1 North buoy was recovered with the sensor out of the water and the float stuck in the up position. At least one of the guide rods on the North buoy was bent preventing the float from moving freely. It is suspected that the damage to the rods was caused by a

vessel that may have tied up to the buoy. The floats deployed to the PACS 2 buoys were observed to be moving freely following their deployment.

i. FSI Current Meter

A Falmouth Scientific, Inc., (FSI), acoustic current meter (ACM) (s/n 1428 a) was deployed at a depth of 130 meters on the PACS 1 South mooring. The FSI current meter "measures velocity along four acoustic paths, three orthogonal magnetic vectors and two orthogonal gravity vectors (tilt) from which it calculates velocity relative to the earth" (FSI 3D-ACM Operating Instructions). In addition to east, north, and vertical components of current velocity, the instrument also recorded temperature, tilt, current direction and time. The instrument was set to record once every 15 minutes, which corresponds to an average measurement of 890 seconds. The remaining 10 seconds were necessary for the instrument to perform the various current calculations and store them in memory without corrupting the current measurement.

Upon recovery of the FSI 3D-ACM, three of the instrument's four fingers which house the acoustic transducers were broken off and missing. Based on a preliminary look at the data, the manufacturer suspects that the loss of the first finger occurred on May 27, 1997, approximately one month after deployment. The cause of the breakage is unknown. The instrument collected a complete record of temperature and tilt data.

Tests conducted by Falmouth Scientific, Inc., concluded that 55 pounds of force are required perpendicular to the tip of the finger for a fracture to occur. The fracture line on the tested fingers was identical to that of the instrument deployed on the PACS 1 mooring, which indicates that the force was applied from the surface toward the sea floor. The manufacturer hypothesizes that the first finger was broken as a result of the instrument coming in contact with a fish of sufficient size to exceed the structural strength of the finger. Downward motion due to the heave of the surface buoy coupled with fish contact may have exceeded the breaking strength of the finger assembly.

j. Sherman Current Meter

This instrument, developed by Russ Davis and Jeff Sherman at SIO, is an acoustic doppler current meter. Two orthogonal acoustic sensors point outward in the horizontal plane at the top of the instrument. Each sensor samples the along-beam velocity in a range bin away from the pressure case, thus avoiding eddies and other flow disturbance near the pressure case and supporting cage. A Sherman current meter was deployed on both the PACS 1 and PACS 2 South moorings at a depth of 120 meters. During PACS 1 it was bracketed by a VMCM and FSI acoustic current meter at 110 and 130 meters respectively. During PACS 2 it was bracketed by a standard VMCM at 110 meters and a VMCM with new electronics at 130 meters depth.

k. Chlorophyll Absorption Meter

A WET Labs Chlorophyll Absorption Meter (CHLAM), model number 9510005, serial number ACH0126, was placed on the PACS 1 South discus mooring at a depth of 50 meters. The CHLAM was mounted on a frame that fit inside a standard 3/4" VMCM cage. A Sea-Bird pump draws water through the CHLAM and a brominating canister. Between samples, the bromide diffuses through the system to reduce bio-fouling. Data are stored to a WET Labs MPAK data logger. The CHLAM/MPAK records a reference and signal from three optical wavelengths, 650, 676 and 712 nautical miles and an internal temperature. The sample interval rate was two hours. At each sample, the pump was turned on for ten seconds to flush the system then ten seconds of sampling with the ten-second aver-

age of signal and reference stored in the MPAK. The complete system was powered by two, 10 D-cell alkaline battery packs.

Upon recovery communications with the MPAK could not be established because the battery packs were both fully depleted. Several attempts to communicate with the instrument were unsuccessful. The instrument was returned to the manufacturer where they were able to recover the data from the logger.

l. Bio-optical Package

A bio-optical package developed by Paul Fucile (WHOI) was deployed on the PACS 2 South mooring at a depth of 27.5 meters. The moored bio-optical package included: a WET Labs., WETStar Miniature Chlorophyll Fluorometer; a Sea Tech, Inc., 25 cm. transmissometer; a Sea-Bird conductivity cell; a Sea-Bird temperature sensor; a LI-COR®, spherical Photosynthetically Active Radiation (PAR) sensor; as well as an upwelling PAR sensor, also by LI-COR®; and a Seapoint Sensors, Inc., turbidity meter. The instrument was controlled by Onset Computer, Corp., tattletale model 4A; and the data are stored on non-volatile PCMCIA in DOS readable files. Thus, the data can be read by a PC with a PCMCIA slot or a resident program in the logger which permits serial downloading of the data. Internal batteries provide power for deployments of up to one year. For the PACS 2 deployment the sampling interval was set at 3.75 minutes.

m. Acoustic Rain Gauge

An acoustic rain gauge from Jeff Nystuen at the Applied Physics Laboratory at the University of Washington was deployed on the PACS 1 North mooring at a depth of 29 meters. This instrument listens to ambient noise with a hydrophone. Rain falling on the sea surface produces noise at certain frequencies which are sampled by this instrument. Upon recovery, the instrument was entangled in fishing net. It appears that when attempts were made to pull the net away from the North mooring, the hydrophone guard cage was damaged. The hydrophone and instrument did not appear to have sustained any damage. Evaluation of the data collected by the acoustic rain gauge indicated that the instrument had an intermittent electronics problem, and, as a result, collected data for only portions of two days while on the mooring.

n. Acoustic Release

An acoustic release was used just above the anchor to release the mooring from the anchor. It was also used as a transponder to precisely locate the anchor on the bottom. The type of release used on the two WHOI moorings was an EG&G model 322. Each release was wire tested to a depth of 1,000 meters prior to deployment.

B. USF Surface Mooring and Instrumentation

The Ocean Circulation Group of USF deployed a "taught line" air-sea interaction surface mooring system during PACS 1. The primary flotation of the mooring was provided by a 7'-6" diameter toroid-shaped fiberglass buoy. The mooring components consisted of 3/8" wire rope; 7/16" wire rope; 1/2" galvanized, long link chain; and 3/4" braided nylon. Mooring attachment hardware included 1", 7/8", 3/4", and 5/8" safety anchor shackles, and 3/4" sling links. The mooring was kept in place with a "5-stack", 4000 pounds railroad wheel anchor. The mooring had a scope of 0.985, where scope is the ratio of mooring length to water depth. Figure 13 shows the USF mooring schematic and a surface buoy profile.

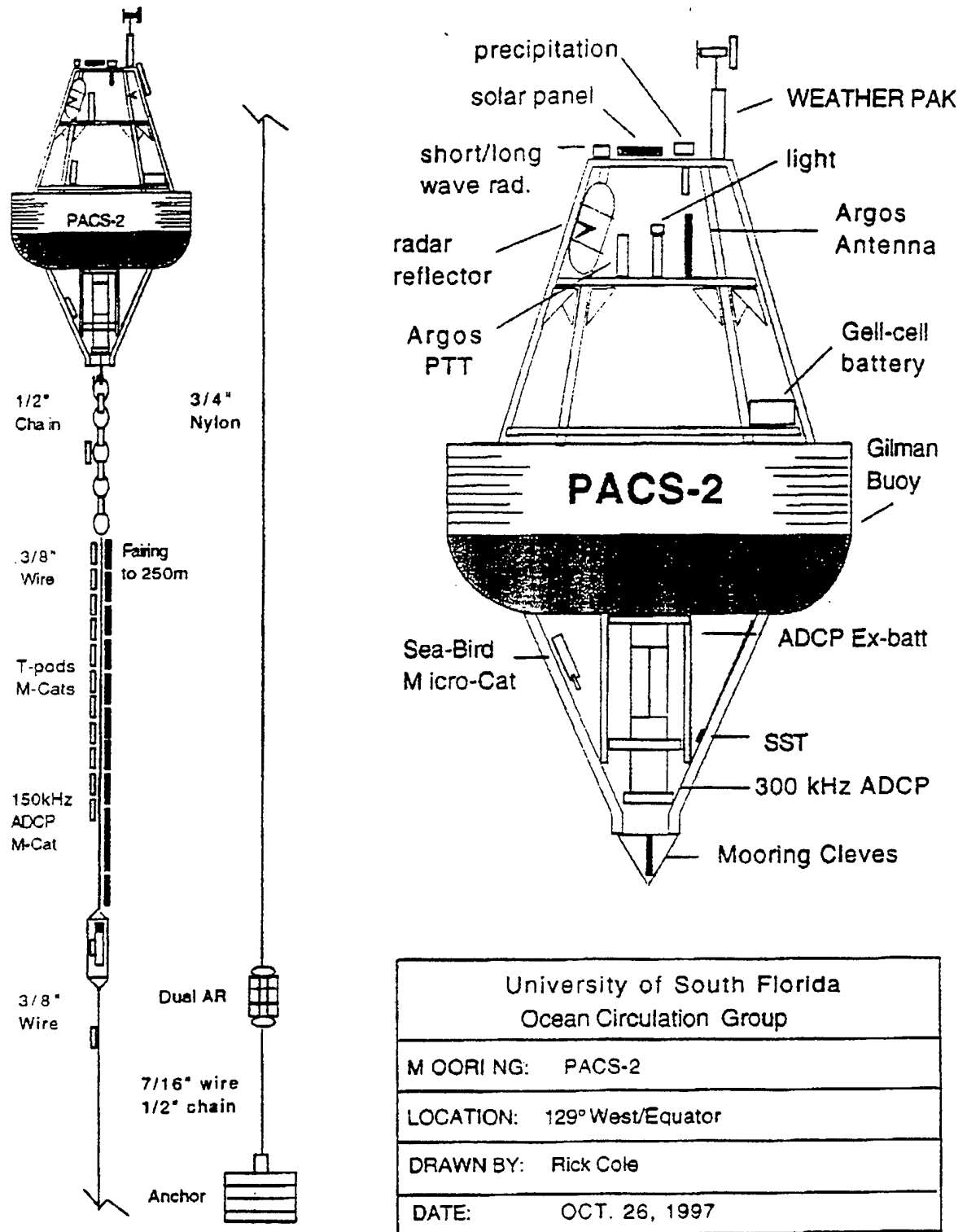

Figure 13: University of South Florida mooring schematic.

Twenty-seven different sensors were deployed on the USF PACS 1 mooring. Mounted on the tower of the surface buoy were eight IMET meteorological sensors, including wind speed and direction, air temperature, short-wave radiation, long-wave radiation, precipitation and barometric pressure. In addition there was a Vitel VX4004 data logger, an Argos. PTT, an IMET/acoustic doppler current profiler (ADCP) module, a radar reflector and marine lantern. Sub-surface instruments included a bridle-mounted, downward-looking 600kHz R.D. Instruments ADCP; a Sea-Bird Electronics SBE-16 conductivity and temperature recorder (SEACAT); and an IMET sea-surface temperature module. Mounted on the 3/8" wire rope were three SBE-16 SEACATs (temperature and conductivity only) and ten, WaDaR temperature recorders. At 250-meters depth there was an upward-looking 150kHz SC-ADCP along with a SBE-16 SEACAT which measured pressure, temperature and conductivity. Dual EG&G, model 8202, acoustic releases held the mooring to the anchor. The USF PACS 1 mooring was recovered successfully during TN 073.

The USF surface mooring deployed during TN 073 was similar to the first USF mooring. The surface buoy differed in that it was a 2.4-meter diameter, Surlyn® foam, toroidal-shaped buoy manufactured by Gilman, Corp., of Gilman, Connecticut. The buoy was outfitted with an aluminum tower and rigid four legged bridle. A Coastal Climate WeatherPak with wind speed and direction, barometric pressure, air temperature, relative humidity, short-wave radiation, long-wave radiation, and precipitation sensors was mounted to the buoy tower. A downward-looking 300 kHz Workhorse ADCP was mounted in the buoy bridle. Ten temperature recorders and five Sea-Bird MicroCAT conductivity/temperature recorders were deployed in the upper 300 meters of the mooring. An upward-looking 150 kHz ADCP was deployed at a depth of 250 meters.

Following anchor launch, the USF PACS 2 surface buoy disappeared from sight. Subsequent interrogation of the acoustic release indicated that a portion of the mooring was on the bottom in close proximity to where the anchor was dropped. Since the mooring did not have any glass ball buoyancy above the release, the only way to recover the mooring was by conducting a dragging operation. Using WHOI dragging gear, a USF acoustic release transponder and a pinger belonging to the ship, the mooring was successfully snagged and brought to the surface. The entire mooring, from surface buoy to acoustic release, was recovered. The Surlyn® foam buoy was noticeably deformed due to the pressure. With the exception of the acoustic release and the Sea-Bird MicroCAT conductivity/temperature recorders, all other instrumentation was either lost or destroyed due to pressure. Details of the events leading up to and during the dragging operation can be found in the appropriate section of the Cruise Chronology. The dragging operation is described in Appendix 7. As there was not enough equipment to replace lost and damaged gear, the USF PACS 2 mooring was not redeployed.

C. Other Instrumentation

1. WHOI Shipboard Meteorological System

Following the deployment of a surface buoy and prior to its recovery, it is a common practice to position the ship approximately .25 miles downwind of the buoy so that shipboard meteorological observations can be made and compared with the data collected by the buoy. While close to the buoy its Argos transmissions can be received, decoded and compared with the shipboard observations. The comparison of data provides a means by which to check that the buoy-mounted sensors have not been damaged during deployment. Similarly if a sensor is damaged during recovery, it may not be able to be recalibrated. If accurate shipboard observations are made prior to recovery, it provides a means by which to evaluate the sensor's performance at the end of the deployment.

An independent meteorological data recording system was mounted to the jackstaff of the *Thompson* for use during the cruise. The system recorded wind speed and direction, air temperature, relative humidity, short-wave radiation, long-wave radiation and barometric pressure. The data was logged through the use of a Campbell Scientific data logger. The relative humidity/air temperature sensor was a Rotronic MP-100 sensor that was aspirated to minimize the effect of solar heating. The bowmast relative humidity sensor was the same as that used in the IMET relative humidity module and the VOS IMET relative humidity with temperature instrument. The wind sensor was an R. M. Young propeller anemometer, also used in the IMET wind module. The short-wave and long-wave radiation sensors were Eppley Laboratory's Precision Spectral Pyranometer (PSP) and Precision Infrared Radiometer (PIR) sensors respectively. Barometric pressure was measured with a Rosemount-type 1201 sensor.

Attached to the bow rail was an Infrared Thermometer, Model No. THI-500, manufactured by Tasco. This instrument was aimed forward and downward, in order to sample the skin temperature of the water just forward of the ship's bow. Figure 14 shows the elevation and angle of the bow-mounted IR SST sensor. The data from the Infrared Thermometer was also recorded on the Campbell data logger. Prior to the recovery of the PACS 1 moorings and following the deployment of the PACS 2 moorings, meteorological observations were made using the WHOI bowmast-mounted meteorological sensors. The bowmast-mounted meteorological system was on and logging data for the entire cruise period.

2. SOLO Drifters

The Sounding Oceanographic Lagrangian Observer (SOLO) is a neutrally buoyant float used to measure the ocean's currents. The float self-ballasts to the desired neutral depth, drifts with the local currents, and after a pre-set time (typically 5-30 days) adds buoyancy to ascend to the surface, transmit information via Argos satellite, and then return to its neutral depth. The cycle is repeated until the batteries die (~200 cycles). During ascent/descent temperature (and optionally conductivity) profiles are recorded for satellite transmission as well. Additionally, the float can be equipped with a vane, causing it to spin when there is vertical flow past the SOLO. This Vertical Current Meter (VCM-SOLO) transmits the time series of T, P, and vertical velocity as measured while at its neutral depth. Two VCM-SOLOs (designated by "VT" following their serial number), and two Temperature-Profiling SOLOs (designated by "T" following their serial number), were deployed during TN 073 cruise. Table 10 lists the deployment locations for the four SOLO floats deployed during TN 073.

Section 3: Cruise Chronology

The buoys, meteorological and oceanographic equipment, and related gear that were needed to recover the moorings set in April-May 1997 and to deploy new moorings in their place were shipped to the University of Hawaii Marine Center on Sand Island, Honolulu, Hawaii. Preparations for the cruise in November-December 1997 were done in a lab and in adjacent space at the Marine Center beginning November 14, 1997. The buoy meteorological instrumentation and telemetry of the meteorological data were checked, both locally and through the Argos data received back at WHOI. In addition, the buoy meteorological data were checked against the meteorological package that was to be mounted on the bow mast of the *Thompson*. Final preparations were done on the VMCMs, Brancker temperature recorders (TPODS), Sea-Bird SEACATs, and other instruments to be deployed on the moorings, including time marks when possible.

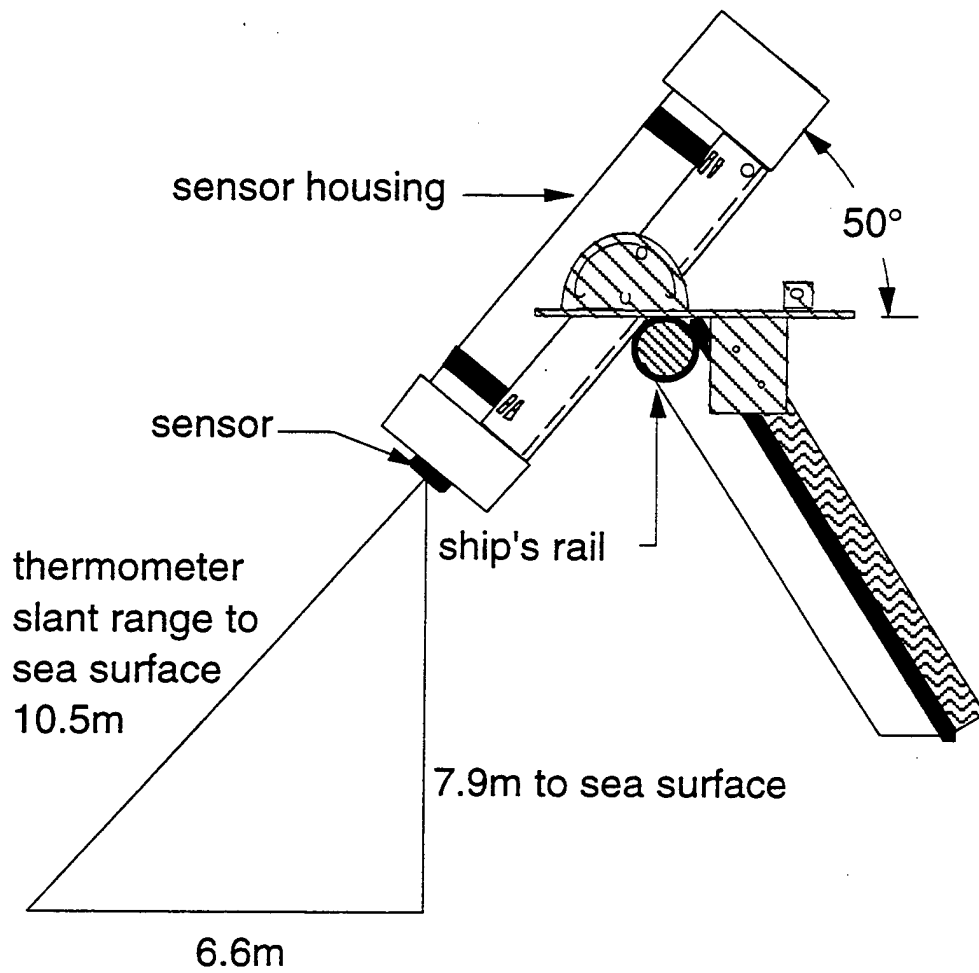

Figure 14: Bow mount for infrared sea surface temperature sensor.

Table 10: SOLO float deployment times and positions.

S/N	Deployment Time	Latitude	Longitude
1022T	3 Dec 97 @ 0627 UTC	9° 00.03'N	141° 22.298'W
1035 VT	6 Dec 97 @ 0900 UTC	0° 02.487'N	128° 01.600'W
1036 VT	11 Dec 97 @ 0222 UTC	0° 04.90'S	127° 52.15'W
1021 T	16 Dec 97 @ 1536 UTC	9° 00.033'N	124° 59.996'W

On November 23, 1997, the *Thompson* arrived at Sand Island. The loading of the equipment began on November 24 and continued at Sand Island through the 25th. Early on November 26, the *Thompson* moved to Pier 2b to make room for R/V *Moana Wave* at the Marine Center. Lashing and other final preparations were completed on November 26 and 27. The layout of the deck at the time of departure and at various stages throughout the cruise can be found in Appendix 8. The ship departed Honolulu at 0730 hours local on November 28, 1997.

From Honolulu, the ship steamed southeast toward the WHOI South mooring location at 3°S, 125°W. Initially, strong trade winds and swells from storms in the eastern North Pacific slowed progress, but after two days the *Thompson* was able to proceed at least at 12.5 knots. On December 2, 1997, the ship stopped to lower three acoustic releases for testing and to take a CTD profile using the WHOI self-contained Sea-Bird CTD (1814 to 1910 UTC, 10°20.816'N, 143°19.37'W). While underway, data from the ship's IMET system were compared with the WHOI bow mast system installed on the foremast and with the meteorological data from the two buoys on deck. The ship's IMET system showed a tendency to lock up, with some variables remaining fixed rather than updating.

Working with Bill Martin, the ship's IMET system was examined and some modules plugged into different connections. All problems were not resolved, especially the tendency of the humidity readings to switch between a valid reading and a reading about half of that. Comparison plots of the ship's IMET, the WHOI bow mast, and the two new buoys on deck were done to look for biases and to prepare for using the bow mast and the ship's IMET system to check the meteorological data on the buoys prior to recovery and after deployment.

On December 3, a profiling, temperature measuring, Lagrangian drifter, SOLO-T SN1022T, was deployed at 0627 UTC at 9° 00.03' N, 141° 22.298' W. This and three other floats were provided by Russ Davis of SIO and checked out in Honolulu by Jeff Sherman (SIO) prior to sailing. On December 6 the ship paused at the USF buoy to conduct a brief visual inspection and a 500-meter CTD cast (1008-1043 UTC; 0° 00.33'N, 127° 57.19'W) A SOLO float (SN 1035VT), which was equipped with blades to make it rotate in response to vertical flow, was deployed on December 6, 0900 UTC; at 0°02.487' N, 128° 01.600'W

WHOI PACS South Surface Mooring

The *Thompson* arrived at the PACS 1 WHOI South mooring early in the morning of December 7. The bridge watch on the *Thompson* noted that the navigation light was not working. The bottom depth, as measured by the ship's Bathy 2000 12 kHz depth recorder, agreed with the SeaBeam chart that was made of the area in April in preparation for the first deployment. The ship was positioned 1/4-1/2 mile downwind during December 7 to attempt to pick up the Argos transmissions from the buoy. Few transmissions had been

received via Service Argos over the preceding several months, and some damage or degradation of the antennas was anticipated. However, transmissions were collected by the shipboard Telonics receivers; and the meteorological data from the buoy compared well with the data being collected on the ship by the *Thompson*'s data acquisition system, the WHOI bow mast, and the fresh buoys on deck.

After breakfast on December 7, the mooring was recovered. The release was fired, and the small boat was used to hook into the glass balls, which were brought on board first. Toward the end of the recovery, the surface buoy, with 40 meters of mooring below, was cast loose and the small boat was again used to attach a lifting pendant. The buoy was lifted on board on the port side, and the remaining instruments then were recovered. Instrumentation from the mooring was inspected and photographed; the buoy hull and instruments were then cleaned.

That evening a 4,000-meter CTD profile was collected, Hydrosweep was used to map a section of the bottom not mapped in April, and set and drift studies were conducted to determine the surface currents. The basic strategy would be to redeploy the mooring at a location close enough to the old site that the bottom survey done in April 1997 could be used again. This made it possible not to devote additional time to mapping the bottom.

In the early morning of December 8 the wind was from 150° at approximately 14 knots, and the surface currents were 38 cm s⁻¹ toward 155°. A track line oriented along 150° was chosen. A start point 15 miles away from the previous anchor site along that bearing was chosen. This allowed not only for the surface current to carry the ship and mooring down onto the target site but also for a deployment lasting roughly eight to nine hours while making 1/2 to 1 knot through the water to stretch out the mooring. The start point was 2° 33.3'S, 124° 47.3'W, and the target anchor site was 2° 46.785'S, 124° 39.385'W. Deployment began approximately 0800 local (1600 UTC). Details of the mooring deployment operations can be found in Appendix 8. The ship moved west of the intended track at first, during the buoy launch and under the influence of a squall, but came back on line. Approximately eight hours later the mooring had been deployed up to the anchor, and the ship had reached flat topography within 20 meters of the target depth. About 0.5 mile short of the old anchor site and over a flat bottom, the anchor was deployed. Following the anchor deployment, an acoustic survey of the anchor site was carried out. The results are summarized in Figure 15. The anchor position was 2°46.235'S, 124°39.749'W, 292 meters back along the track line from the anchor deployment position (2°46.353 S, 124°39.642'W).

That evening the ship was kept close (1/2-1/4 mile downwind, bow into the wind) to collect data to intercompare the buoy and ship meteorological measurements, and a 1,000-meter CTD profile was collected. On the morning of December 9 (0630 local, 1430 UTC), the ship was brought next to the buoy in a slow pass to maximize local Argos reception and to examine the buoy. Everything looked good, with a waterline averaging close to the 12 inches down from the deck as expected. Waves sometimes broke on the deck, and the floating sea-surface temperature sensor was seen to be sliding up and down. After that, the ship departed for the USF mooring site.

CTDs along 125°W

After leaving the site of the WHOI PACS 2 South surface mooring, the *Thompson* steamed northwest to the site of the USF mooring. Along this track, a series of 1,000-meter CTD stations were begun that would be made every 0.5° of latitude. Following the USF mooring work, the ship went to 2° N, 125°W, again taking CTDs every 0.5° latitude. Northward along 125°W up to 10°N, the CTDs were continued, with the last CTD made just northwest of the new WHOI North mooring on December 19, 1997.

While underway, the instruments from the recovered WHOI South buoy were brought into the main lab. Final time marks were put on the data records. Solid-state and disk-recording instruments (SEACATs, Branckers, MTR, WaDaR, IMET, FSI) had their data read. The tapes from the tape recording instruments (VMCM, VAWR) were read. Brancker and SEACAT temperature records were plotted so that four Branckers could be selected for use on the redeployed WHOI North mooring. The data files from all instruments were copied to several back-up media.

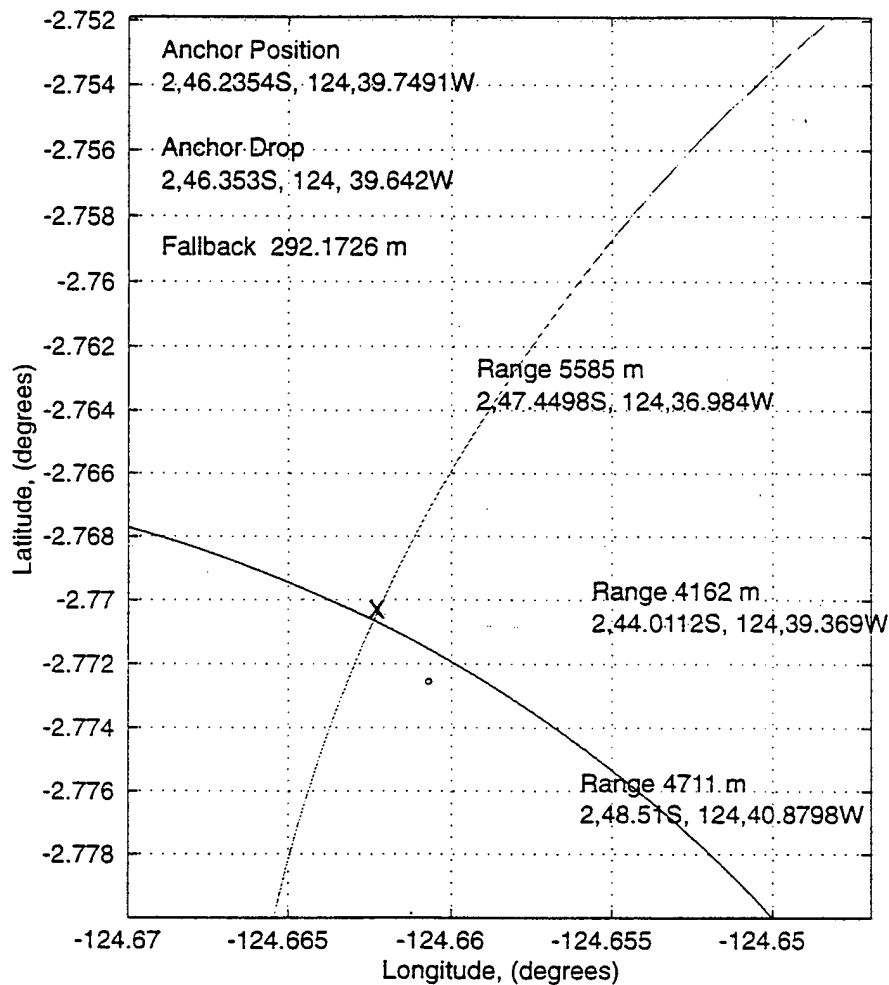

Figure 15: PACS 2 South acoustic release survey.

University of South Florida Surface Mooring

On December 10, 1997, the USF mooring was recovered. The small boat was used to attach a lifting line to the surface buoy, which was recovered first and through the A-frame. The mooring recovery proceeded without incident.

In the evening (0222 UTC, December 11), a vertical current meter float, SOLO SN 1036VT, was launched at $0^{\circ} 04.9'S$, $127^{\circ} 52.13'W$. An acoustic survey of the bottom was conducted, a 4,000-meter CTD station was made, and the set and drift were examined in preparation of deploying a new USF buoy in the morning.

On December 11, the USF mooring was redeployed. The mooring was deployed buoy first. After the anchor was dropped, the surface buoy was tracked by radar until lost in a rain squall. After the rain squall passed, the surface buoy could not be located. The acoustic release was still in place on the bottom, and its location was surveyed in. Because it was thought that the mooring may have parted and left the surface buoy adrift, the evening of December 11 was used to search visually and with radar for the surface buoy.

On December 12 it was concluded that the buoy had sunk, and the decision was made to attempt to recover it by dragging. Dragging gear was deployed and used to hook the mooring. The release was fired and the mooring was recovered during the evening of December 12 and early on December 13. Close to the surface, the foam buoy regained enough buoyancy to rise to the surface and float. As there was not enough equipment to replace lost and damaged gear, it was not possible to redeploy. Thus, shortly after 0500 local on December 13, the *Thompson* got underway to WHOI North, heading toward $2^{\circ}N$, $125^{\circ}W$, from which it would steam north along $125^{\circ}W$. The last SOLO float, SN 1021T, was deployed at $9^{\circ}00.033'N$, $124^{\circ} 59.996'W$, at 1536 UTC on December 16.

WHOI PACS North Surface Mooring

The *Thompson* arrived at the northern mooring site around 1430 local on December 16. A quick visual inspection was made, and the ship moved off to take a 4,000-meter CTD. On December 17, the mooring was recovered. The glass balls came on board first after being hooked by the rescue boat, and then the mooring components recovered up to 40 meters below the buoy. As with the South buoy, the buoy was cast adrift and the small boat was used to attach a lifting line. The buoy hull and upper 40 meters of the mooring were then recovered by lifting them aboard on the port side. As the instruments and buoy came on board there was evidence of damage and sensor fouling. Portions of fishing nets were found entangling many instruments. Some damage to instruments seemed to occur when attempts were made to pull the fouled nets from the mooring. There was also evidence that the buoy had come in contact with another vessel, damaging some of the meteorological sensors.

After recovery, the instruments were inspected, notes were made, and photographs were taken to document their condition. After this, the instruments and buoy hull were cleaned.

The plan of redeploying a new mooring along the same line over the bottom as used in April was not possible due to the strength of the wind and its direction (from 035°). Thus, the night of December 17 was used to conduct a new acoustic bottom survey, to check set and drift, and to conduct trial runs along different courses. A trial run along 045° confirmed that the ship could not hold that course while making between 0.5 and 1.5 knots

through the water. A course of 035° was more successful. Thus, for the mooring deployment on December 18, an initial point of 9°49.0'N, 125°29.2'W and an anchor drop target of 9°57.0'N, 125°23.8'W were chosen. The ship would head along 035°, and was initially positioned nine miles from the target. The wind came up, gusting to 30 knots, so the ship was moved closer, about 7.5 miles away from the target and to the south of the track line. During the night, drift to the north was noted, so the ship was initially positioned south of the desired track line, anticipating it would drift north while the buoy was being lifted over the side.

The mooring deployment proceeded without event. The deployment began at 1630 UTC on December 18. All gear except the anchor was over the side and being towed by 2310 UTC. Since at this point, the ship was approximately two miles from the target anchor site and making only about 0.2 to 0.5 knots over the ground, it was decided to deploy the mooring as soon as the bottom topography permitted. Good bottom topography and a depth close to 4650 meters were found after a tow of close to 1.5 hours; the anchor was dropped at 0119 UTC on the December 19. Following deployment the position of the anchor (Figure 16) was determined by an acoustic survey. The anchor was located at 9°55.7874'N, 125°24.7728'W, 412 meters from the anchor drop site, for a fallback of 8.8%.

The *Thompson* stayed near the buoy over night for comparison of ship and buoy meteorological sensors. In the morning, a visual inspection was made. After a 1,000-meter CTD was made 1.5 miles northwest of the buoy, the *Thompson* got underway to return to Honolulu.

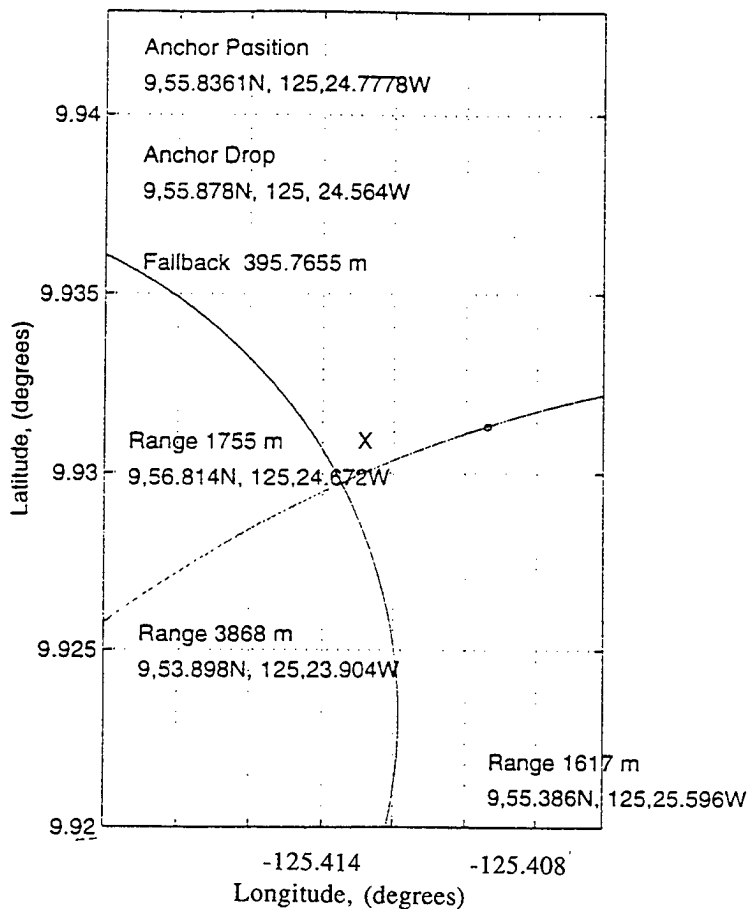

Figure 16: PACS 2 North acoustic release survey.

Steaming to Honolulu and arrival

While underway to Honolulu, the recovered buoy hulls were broken down for shipment home. Time marks were placed on the records of the instruments recovered from the PACS 1 North mooring. Data files were read and backed-up as had been done earlier for the instruments from WHOI South. The equipment brought on board was packed for shipment back to WHOI.

The ship arrived at the sea buoy off Honolulu at 0800 local on December 26. Unloading and final packing was done on December 26 and 27. Containers for surface shipment and boxes for air freight were loaded, and work in Hawaii was completed on December 28, 1997.

Acknowledgments

The captain and crew of the R/V *Thomas Thompson* deserve special mention for their willingness to make this cruise a successful one. Their professional and friendly manner make them a pleasure with whom to work. For all those who hauled glass balls, dragged wire rope coils, worked the Lebus winch and assisted wherever a helping hand was needed, we thank you. Special thanks to the Bill Martin (Marine Technician) for his help with the moorings and CTD work.

The WHOI moorings were designed by George Tupper, and, as always, were carefully prepared by the WHOI Mooring and Rigging Shop under the watchful supervision of Dave Simoneau. We sincerely thank Penny Foster for her help in preparing this report.

This work was supported by the National Oceanic and Atmospheric Administration Grant No. NA66GP0130.

References

- Falmouth Scientific, Inc., 3-D Acoustic Current Meter, 3-D-ACM, Version 6.0, Firmware Version 2.54, Operating Instructions, 126 pp.
- Heinmiller, Robert H., 1976. Mooring Operations Techniques of the Buoy Project at the Woods Hole Oceanographic Institution. Woods Hole Oceanographic Institution Technical Report, WHOI-76-69, 94 pp.
- Trask, Richard P., Bryan S. Way, William M. Ostrom, Geoffrey P. Allsup, and Robert A. Weller, 1995. Arabian Sea Mixed Layer Dynamics Experiment, Mooring Deployment Cruise Report, R/V *Thomas Thompson* Cruise Number 40, 11 October-25 October 1994. Upper Ocean Processes Group, UOP Technical Report 95-1, Woods Hole Oceanographic Institution Technical Report, WHOI-95-01, 64 pp.
- Trask, Richard P., and Robert A. Weller, 1995. Cyclic Fatigue Testing of Surface Mooring Hardware for the Arabian Sea Mixed Layer Dynamics Experiment. Upper Ocean Processes Group, UOP Technical Report 95-15, Woods Hole Oceanographic Institution Technical Report, WHOI-95-16, 63 pp.

Way, Bryan S., William M. Ostrom, Robert A. Weller, Jonathan D. Ware, Richard P. Trask, Rick Cole, and Jeff Donovan. Pan American Climate Study (PACS), Mooring Deployment Cruise Report, R/V *Roger Revelle*, Cruise Number Genesis 4, 9 April - 5 May 1997. Upper Ocean Processes Group, UOP Technical Report 98-01, Woods Hole Oceanographic Institution Technical Report 98-07, in preparation.

Appendix 1

Cruise Participants

Woods Hole Oceanographic Institution

Robert Weller (Chief Scientist)
William Ostrom
Bryan Way
Richard Trask

University of South Florida

Robert Weisberg
Rick Cole
Jeff Donovan
Jyotika Virmani

University of Washington

Bill Martin (Marine Technician)

Appendix 2

CTD stations occupied during TN 073

A total of 31 CTD stations were taken during TN 073. A Sea-Bird model 19-04 CTD with pump was used for all stations. No water samples were collected in conjunction with the casts. The first station taken was a test of the system. The second station was a 500-meter deep cast taken at the USF mooring while enroute to the PACS 1 South mooring.

After completing the mooring work at the WHOI PACS 2 South site the *Thompson* steamed back to the USF mooring. Along this track, a series of 1,000-meters CTD stations were begun that would be made every 0.5 deg of latitude. Following the USF mooring work, the ship went to 2° N, 125°W, again taking CTDs every 0.5° latitude. Northward along 125°W up to 10°N, the CTDs were continued, with the last CTD made just northwest of the PACS 2 WHOI North mooring on December 19, 1997.

Table A2-1 lists the CTD locations, along with the date and time the station was started and the maximum depth attained. Figure A2-1 is a chart showing the CTD station locations along the cruise track. Deep stations down to 4000 meters were taken at the three mooring sites. Figure A2-2 is a composite plot of CTD data taken along 125°W longitude during TN 073. It contains 3 sections showing salinity, potential temperature and potential density. Figure A2-3 through Figure A2-17 are profiles of potential temperature, salinity and sigma-t from the CTD data collected during TN 073.

Table A2-1: CTD stations taken during TN 073

CTD No.	Date	Start Time [UTC]	Start Latitude dd°mm.mm'	Start Longitude ddd°mm.mm'	Depth [m]
1	2 Dec 97	1814	10°20.816'N	143°19.377'W	1000
2	6 Dec 97	1008	00°00.033'N	127°57.198'W	500
3	7 Dec 97	0745	02°42.95'S	124°42.70'W	4000
4	9 Dec 97	0822	02°47.991'S	124°38.45'W	1000
5	9 Dec 97	1652	02°30.031S	124°59.348'W	1000
6	9 Dec 97	2158	01°59.904'S	125°36.174'W	1000
7	10 Dec 97	0358	01°30.033'S	126°11.906'W	1000
8	10 Dec 97	0812	01°00.137'S	126°50.437'W	1000
9	10 Dec 97	1315	00°30.029'S	127°25.216'W	1000
10	11 Dec 97	0431	00°00.014'N	127°57.056'W	4000
11	13 Dec 97	1726	00°29.991'N	127°11.831'W	1000
12	13 Dec 97	2245	01°00.000'N	126°28.900'W	1000
13	14 Dec 97	0410	01°30.028'N	125°45.032'W	1000
14	14 Dec 97	0953	02°00.07'N	124°59.99'W	1000
15	14 Dec 97	1329	02°30.04'N	124°59.96'W	1000
16	14 Dec 97	1703	03°00.063'N	124°59.983'W	1000
17	14 Dec 97	2038	03°30.006'N	124°59.908'W	1000
18	15 Dec 97	0018	03°59.993'N	124°59.938'W	1000
19	15 Dec 97	0402	04°29.925'N	124°59.976'W	1000
20	15 Dec 97	0749	05°00.035'N	125°00.035'W	1000
21	15 Dec 97	1134	05°30.07'N	125°00.00W	1000
22	15 Dec 97	1512	05°59.99'N	125°00.00'W	1000
23	15 Dec 97	1855	06°29.995'N	124°59.937'W	1000
24	15 Dec 97	2238	07°01.050'N	124°59.998'W	1000
25	16 Dec 97	0223	07°29.963'N	124°59.994'W	1000
26	16 Dec 97	0726	08°07.328'N	124°58.373'W	1000
27	16 Dec 97	1042	08°30.04'N	124°59.99'W	1000
28	16 Dec 97	1427	08°59.99'N	125°00.00'W	1000
29	16 Dec 97	1814	09°29.990'N	125°00.034'W	1000
30	17 Dec 97	0803	09°59.55'N	125°17.89'W	4000
31	19 Dec 97	1900	09°56.696'N	125°27.916'W	1000

Note: The time and location are those associated with the start of the CTD profile.

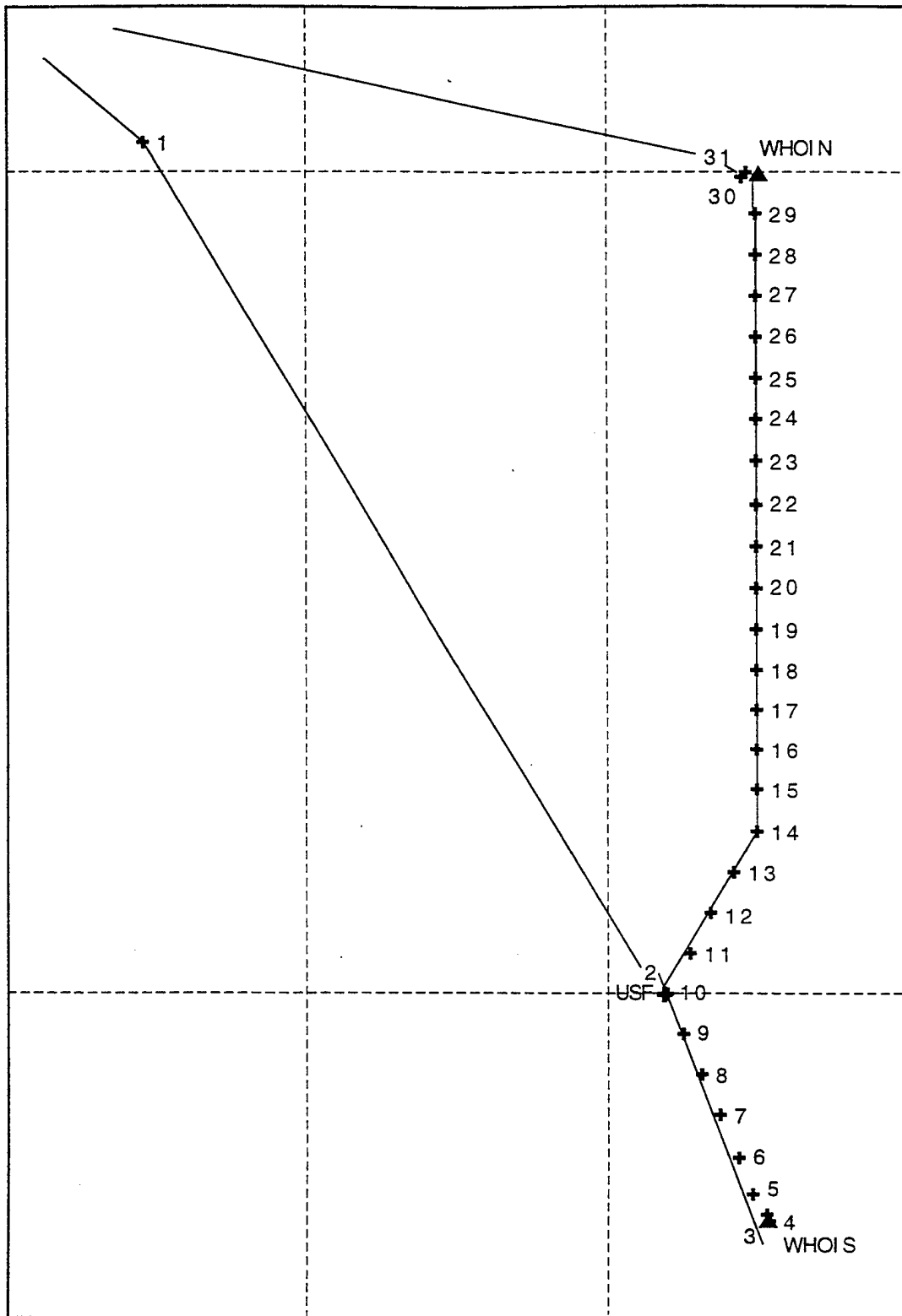

Figure A2-1: Chart showing CTD station locations.

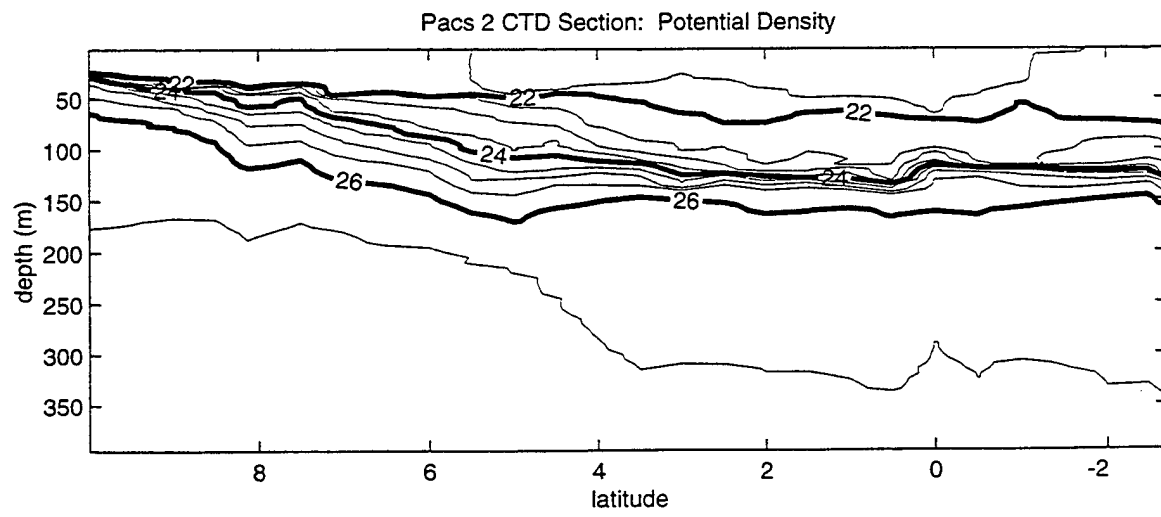
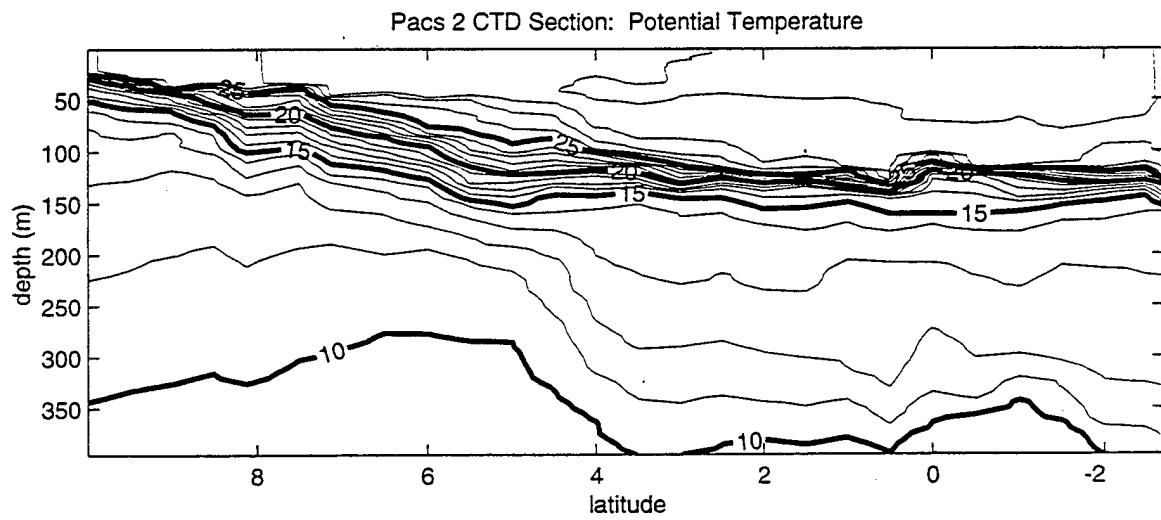
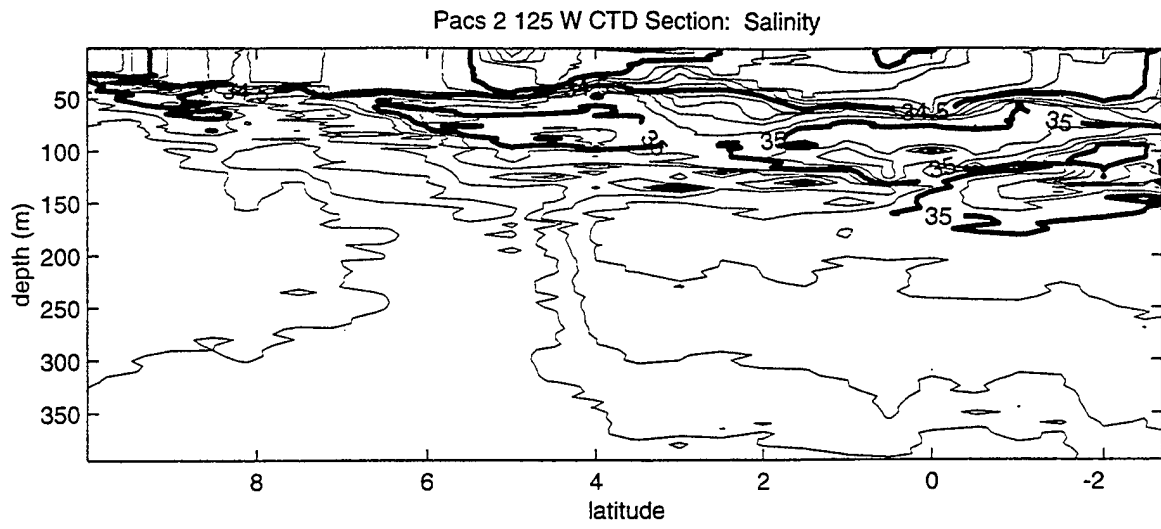

Figure A2-2: Composite plot of CTD data taken during TN 073.

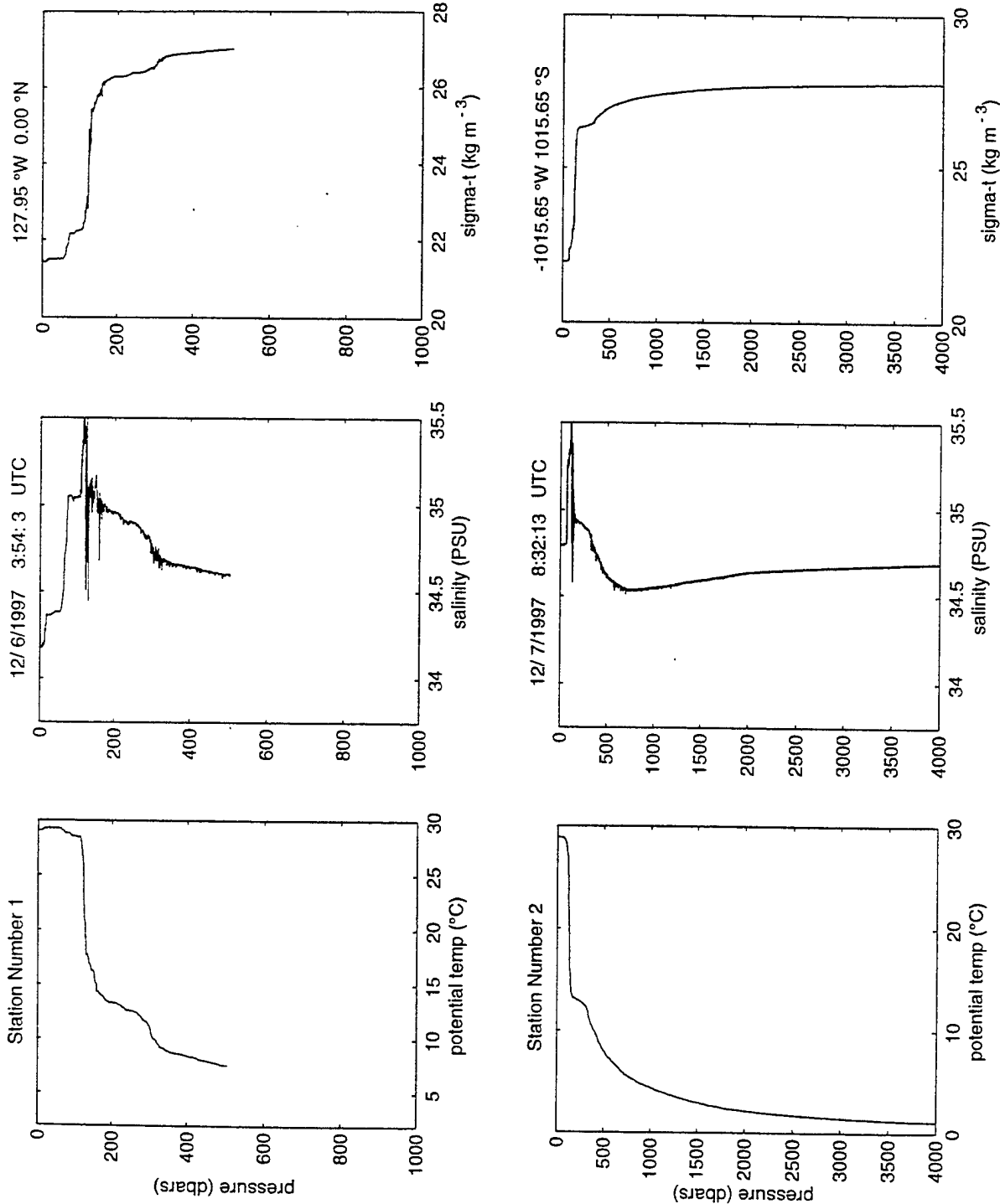

Figure A2-3: Profiles of potential temperature, salinity, and sigma-t from CTD stations 1 and 2.

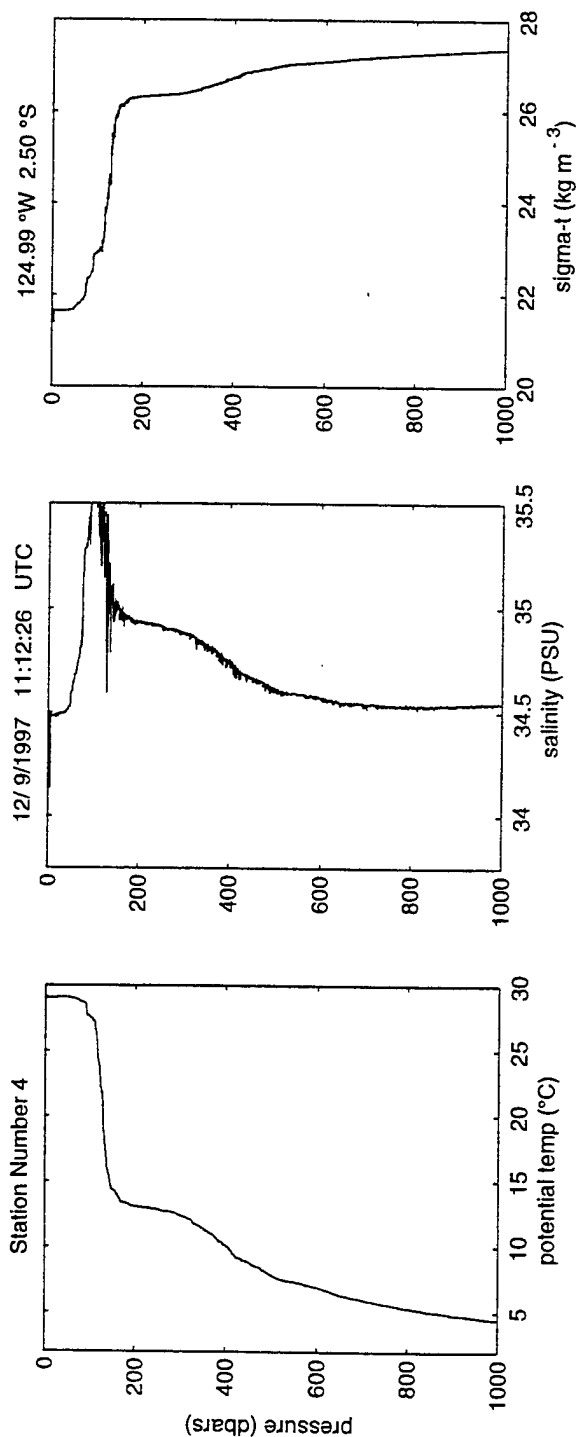
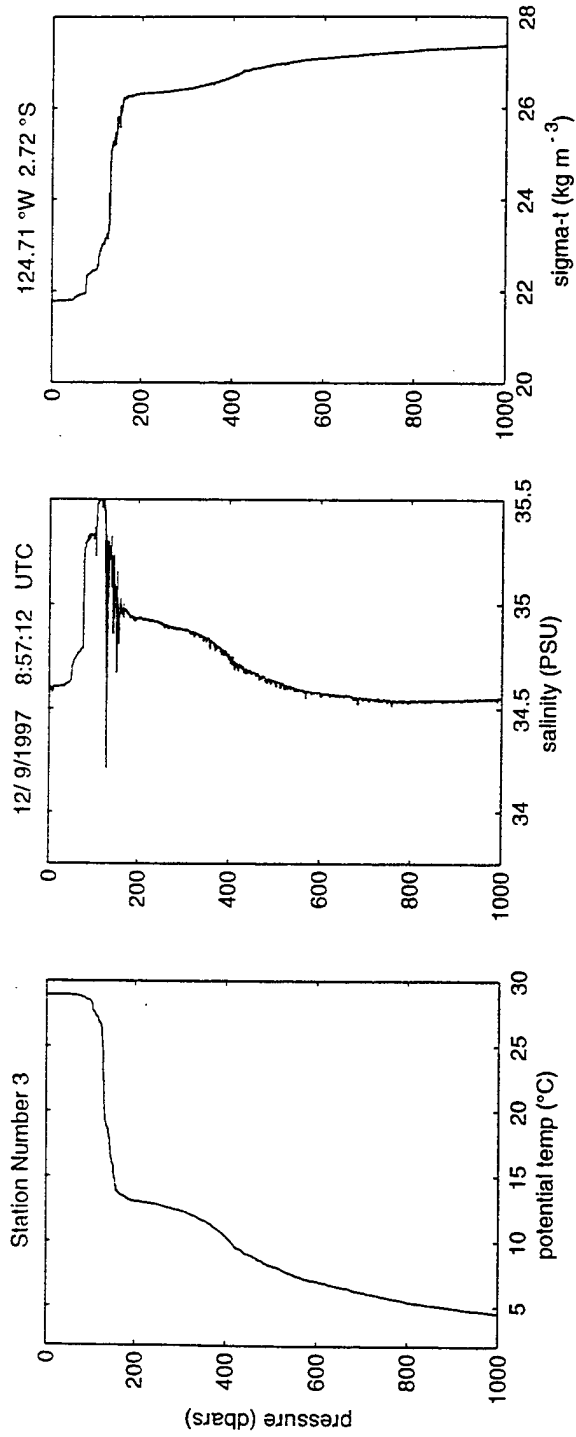

Figure A2-4: Profiles from CTD stations 3 and 4.

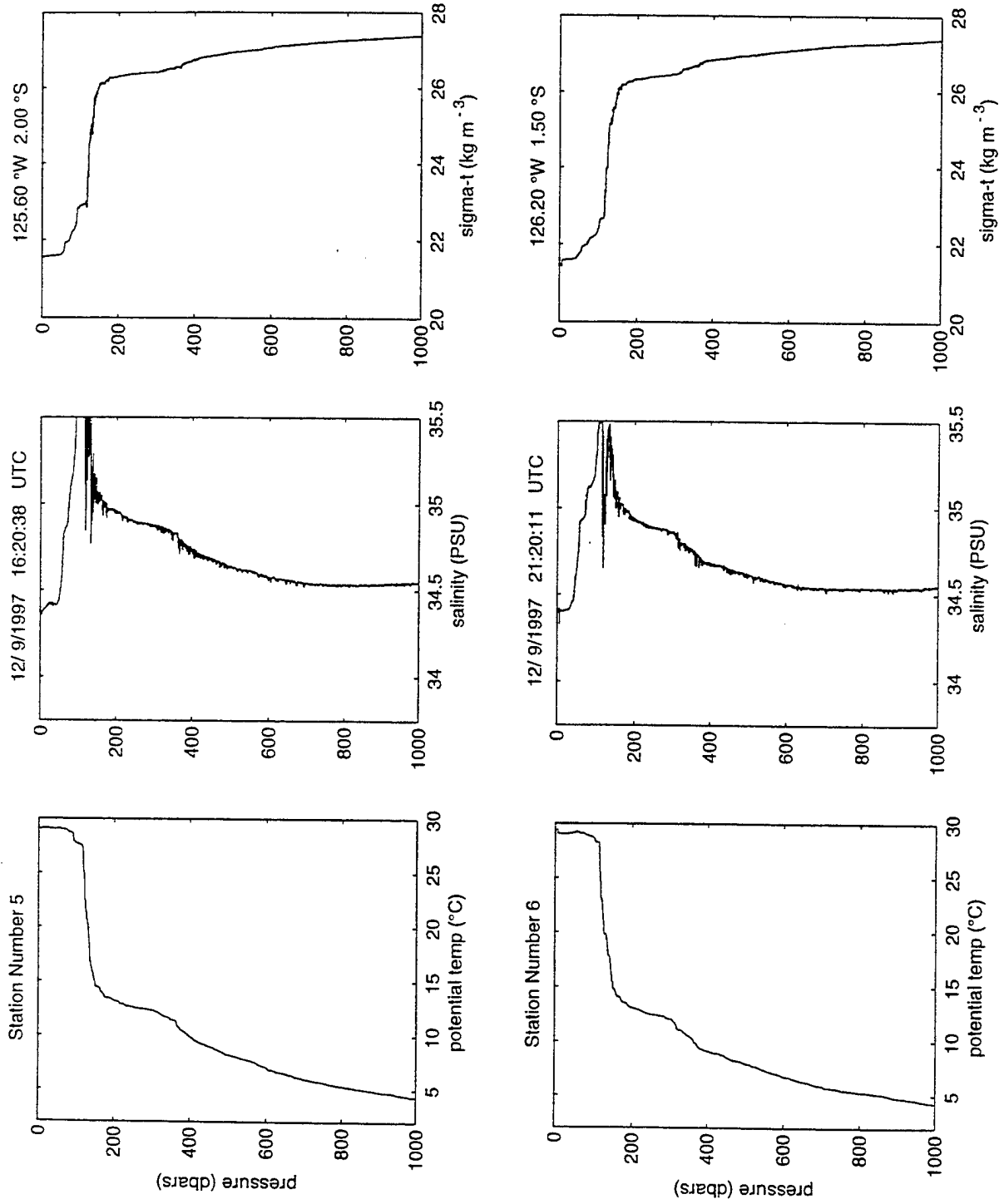

Figure A2-5: Profiles from CTD stations 5 and 6.

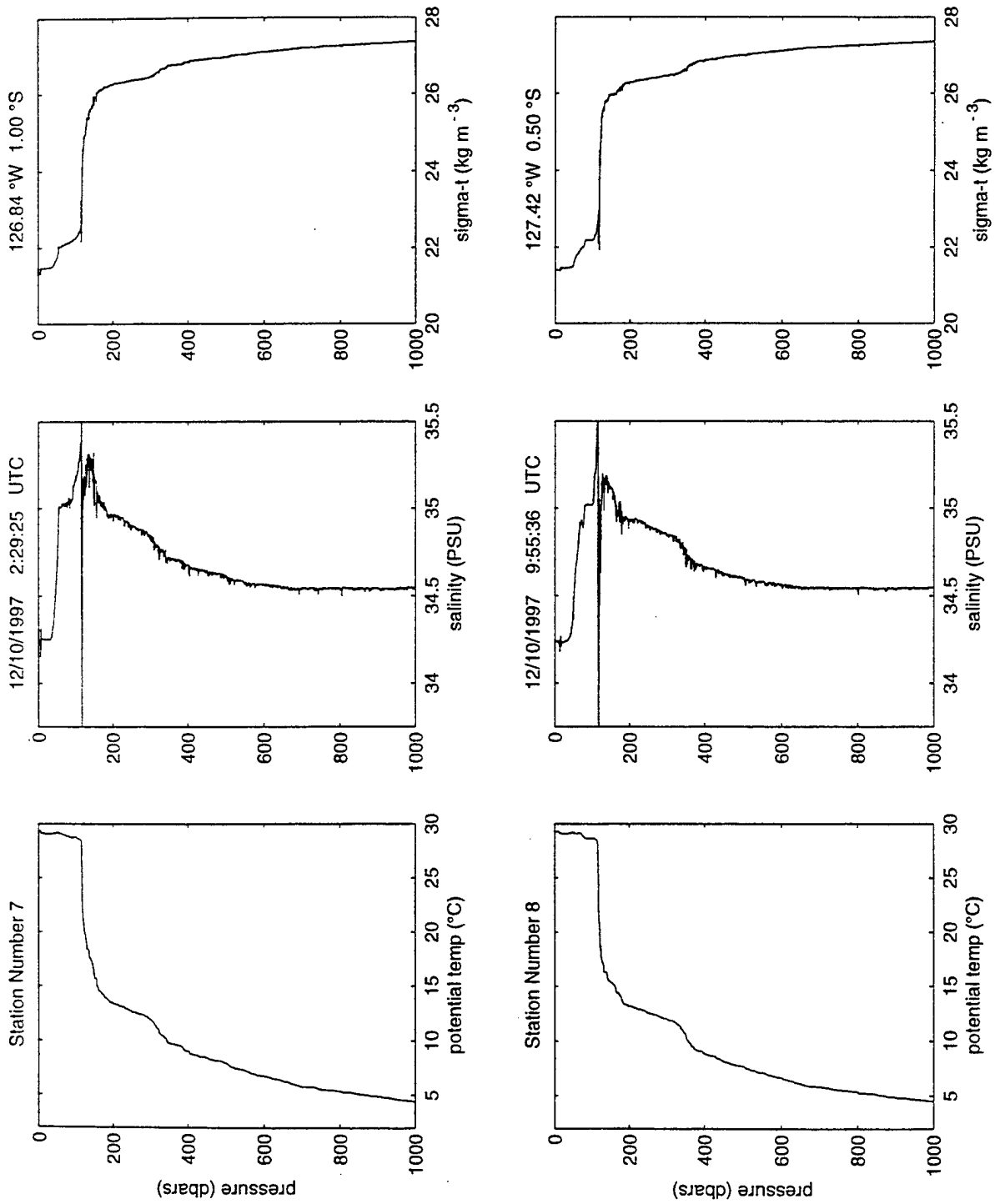

Figure A2-6: Profiles from CTD stations 7 and 8.

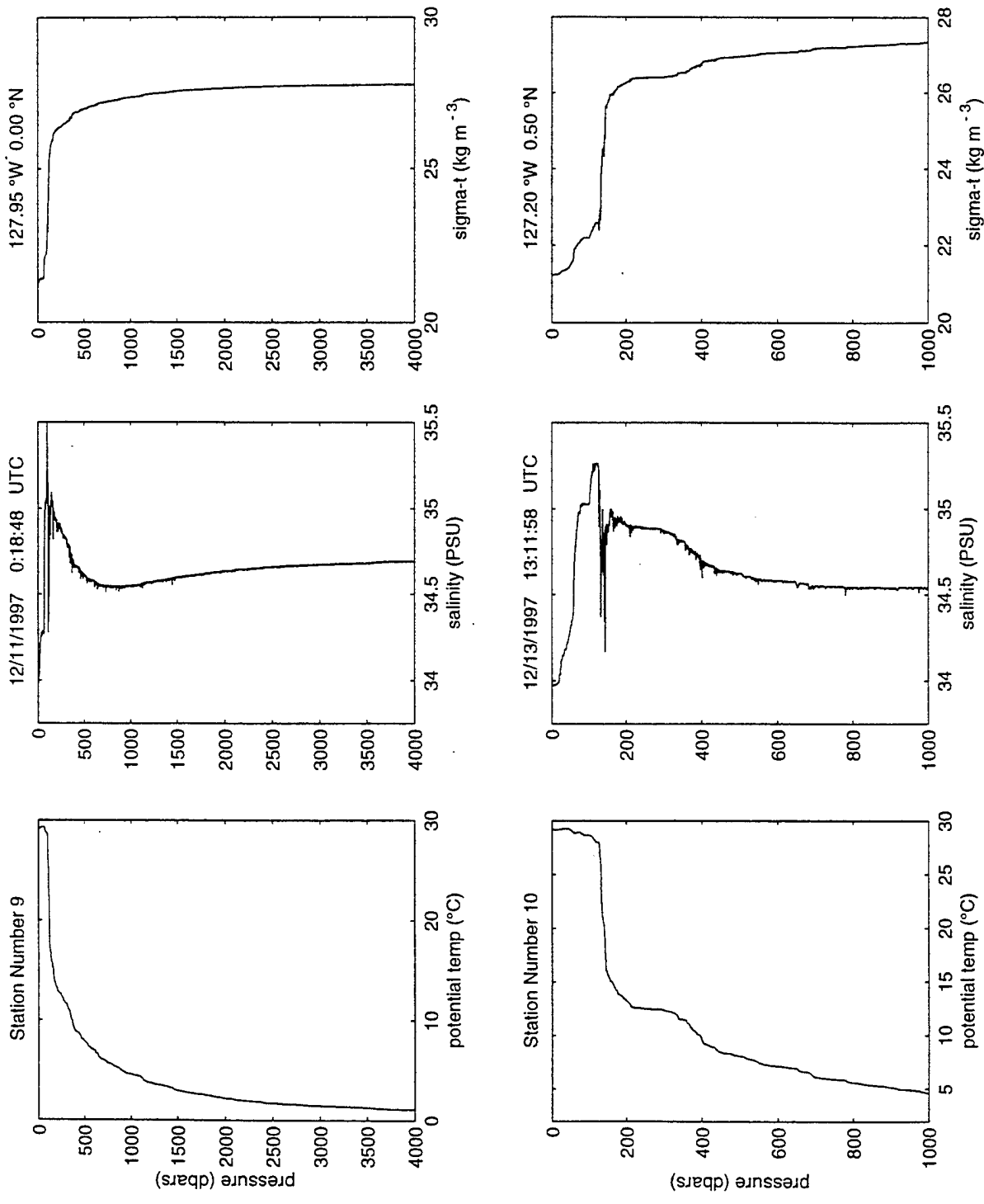

Figure A2-7: Profiles from CTD stations 9 and 10.

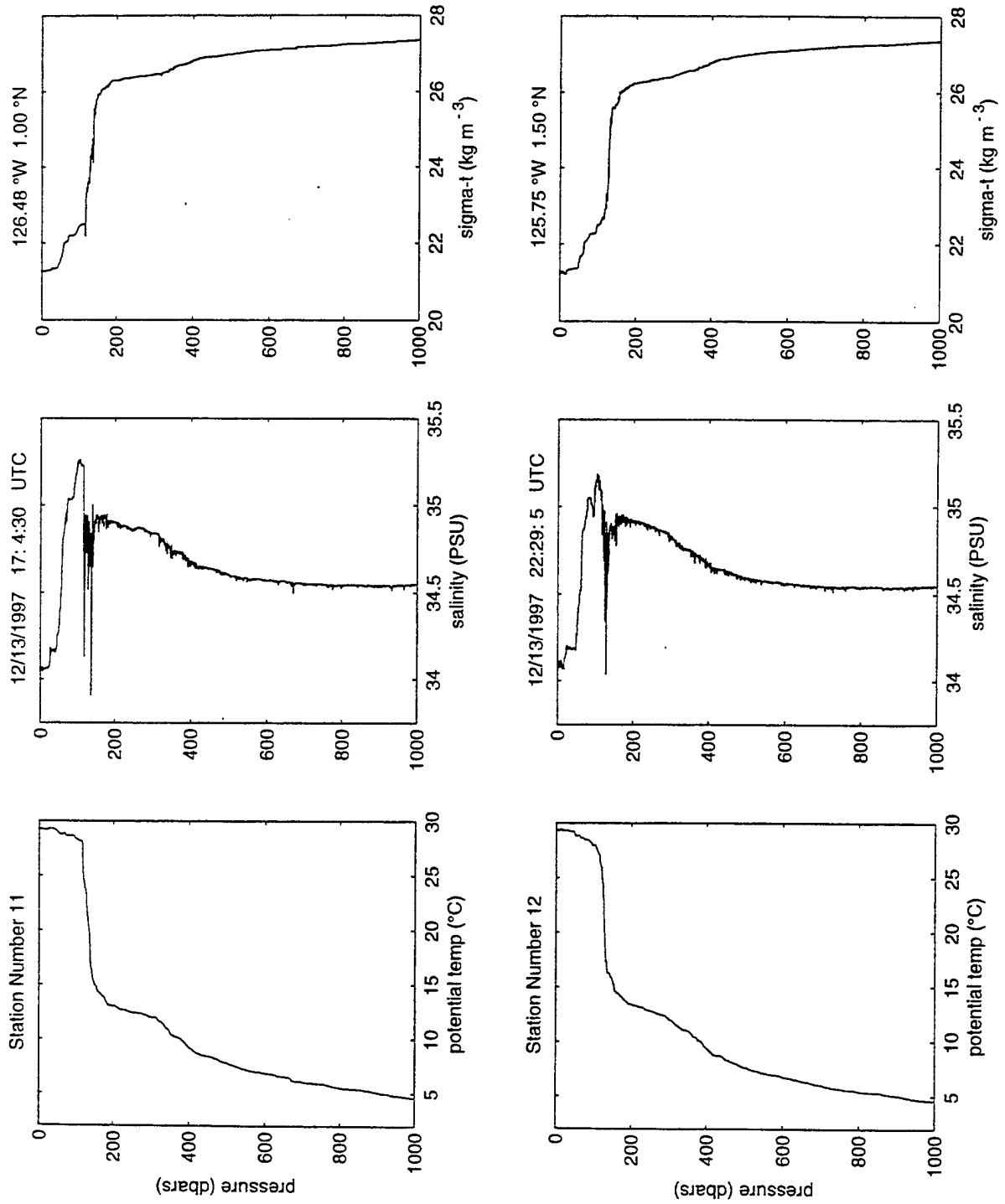

Figure A2-8: Profiles from CTD stations 11 and 12.

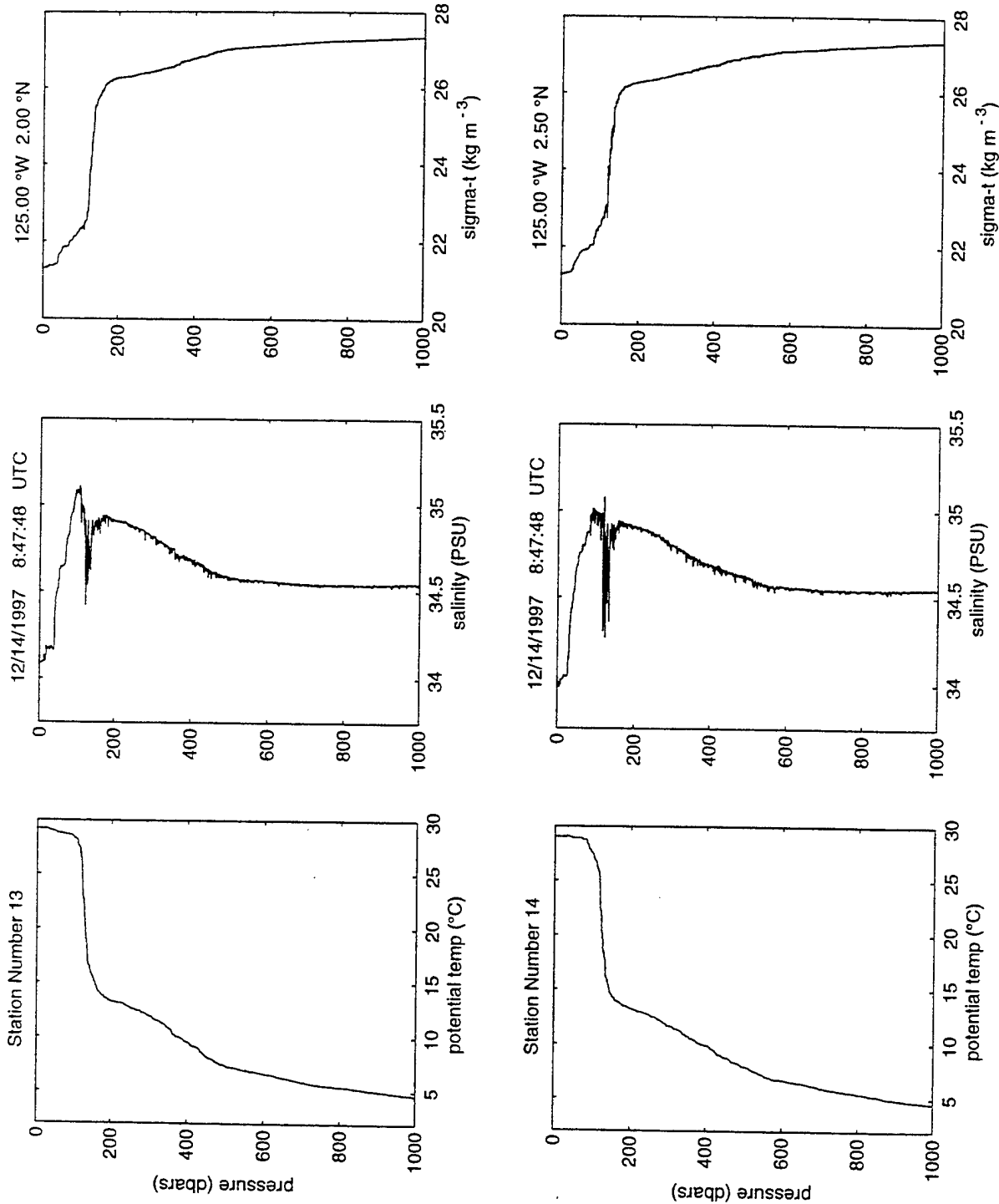

Figure A2-9: Profiles from CTD stations 13 and 14.

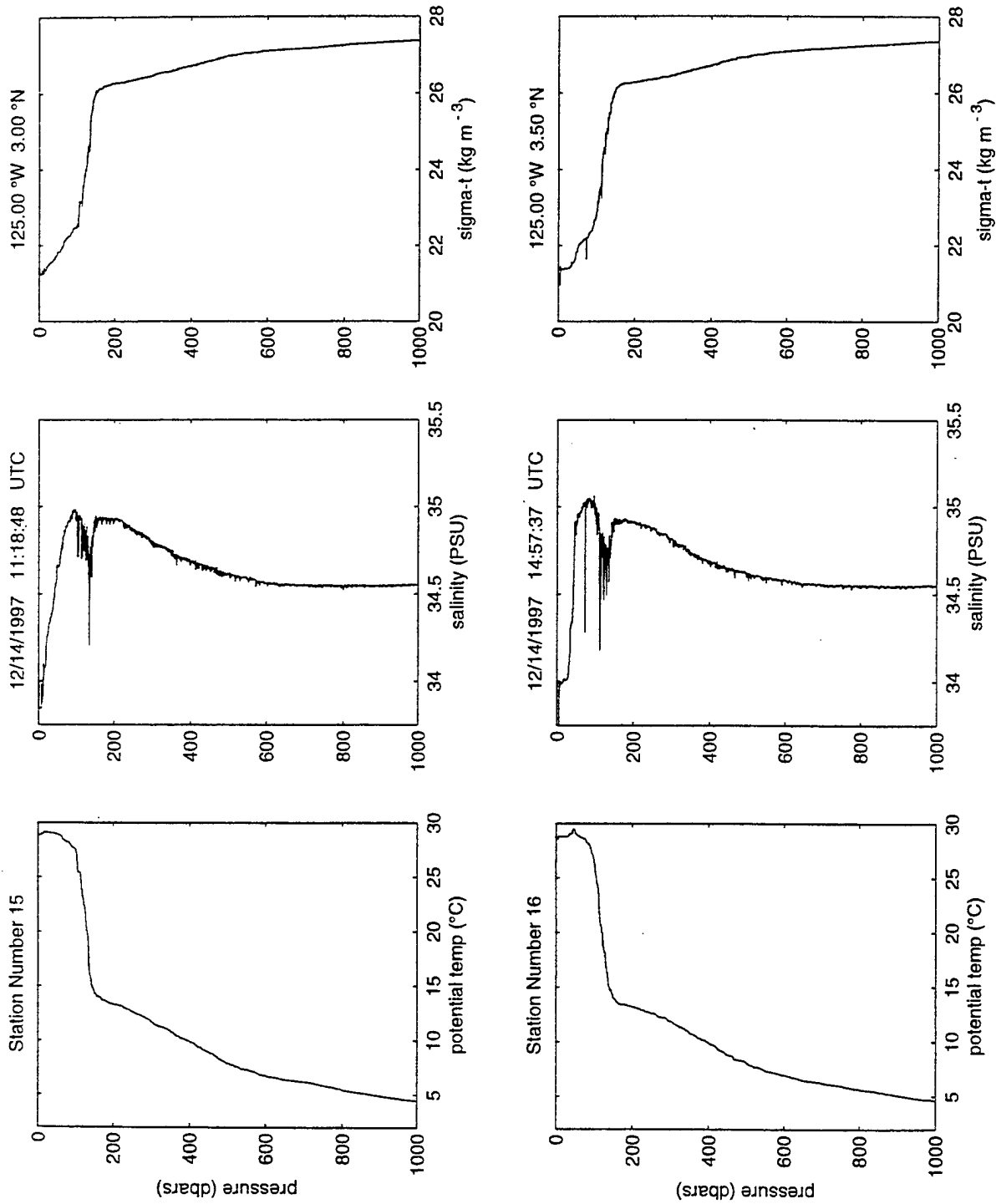

Figure A2-10: Profiles from CTD stations 15 and 16.

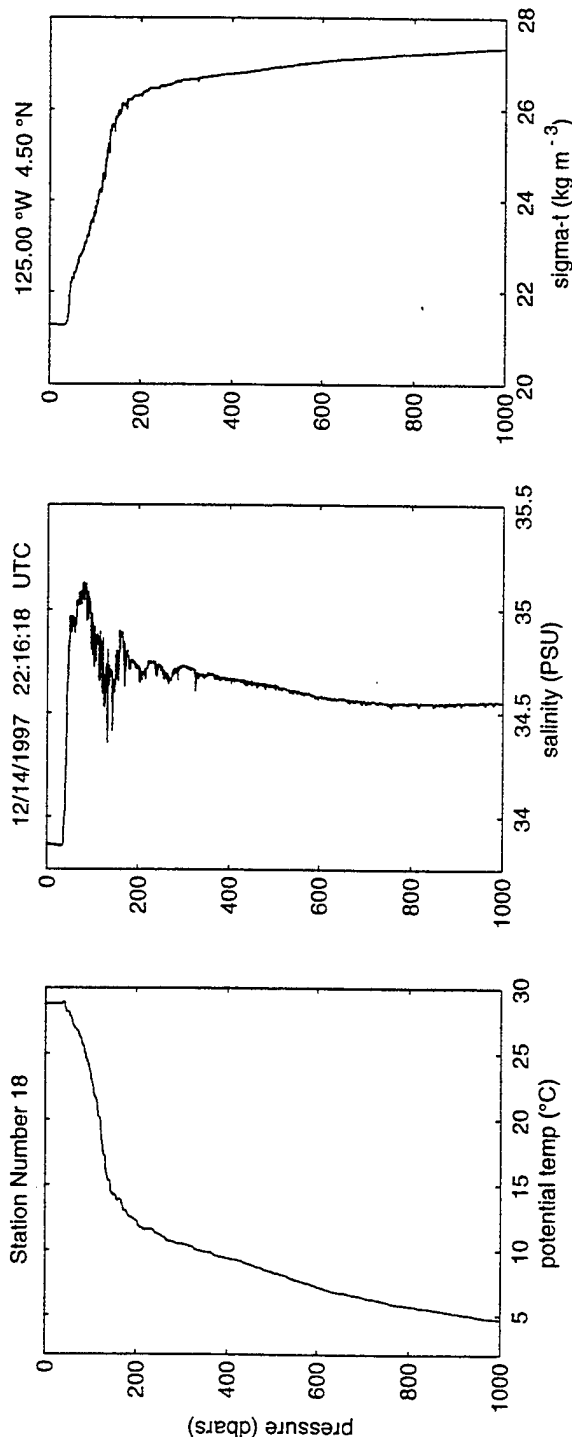
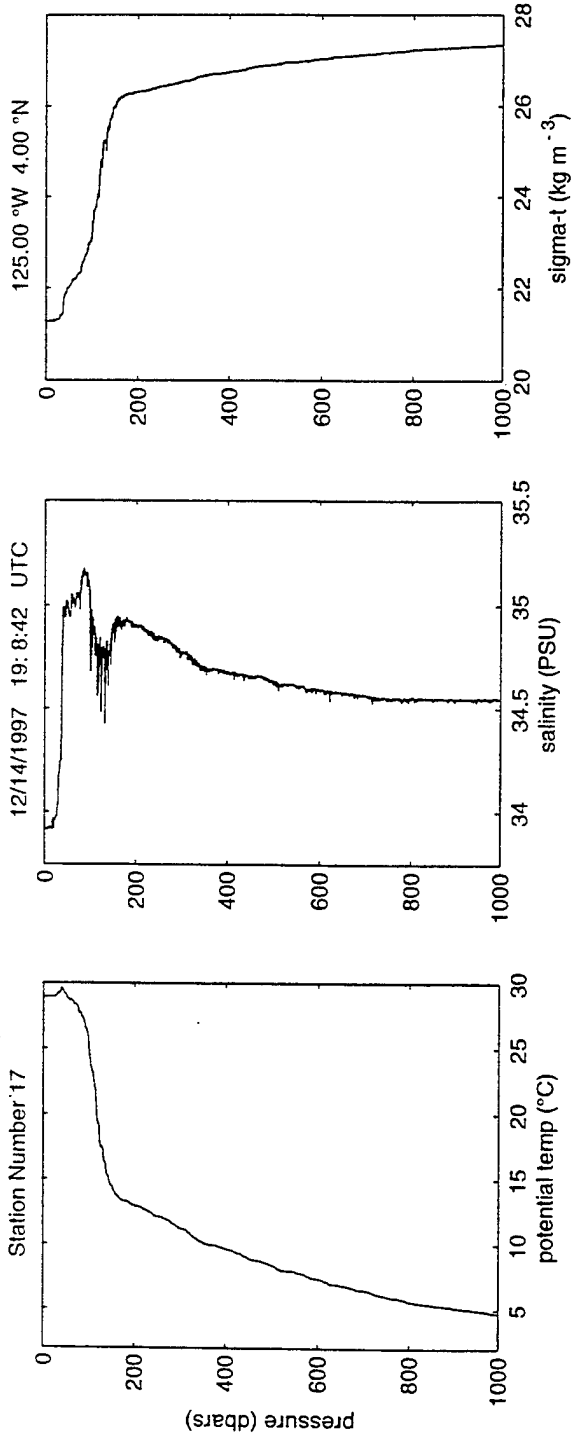

Figure A2-11 Profiles from CTD stations 17 and 18.

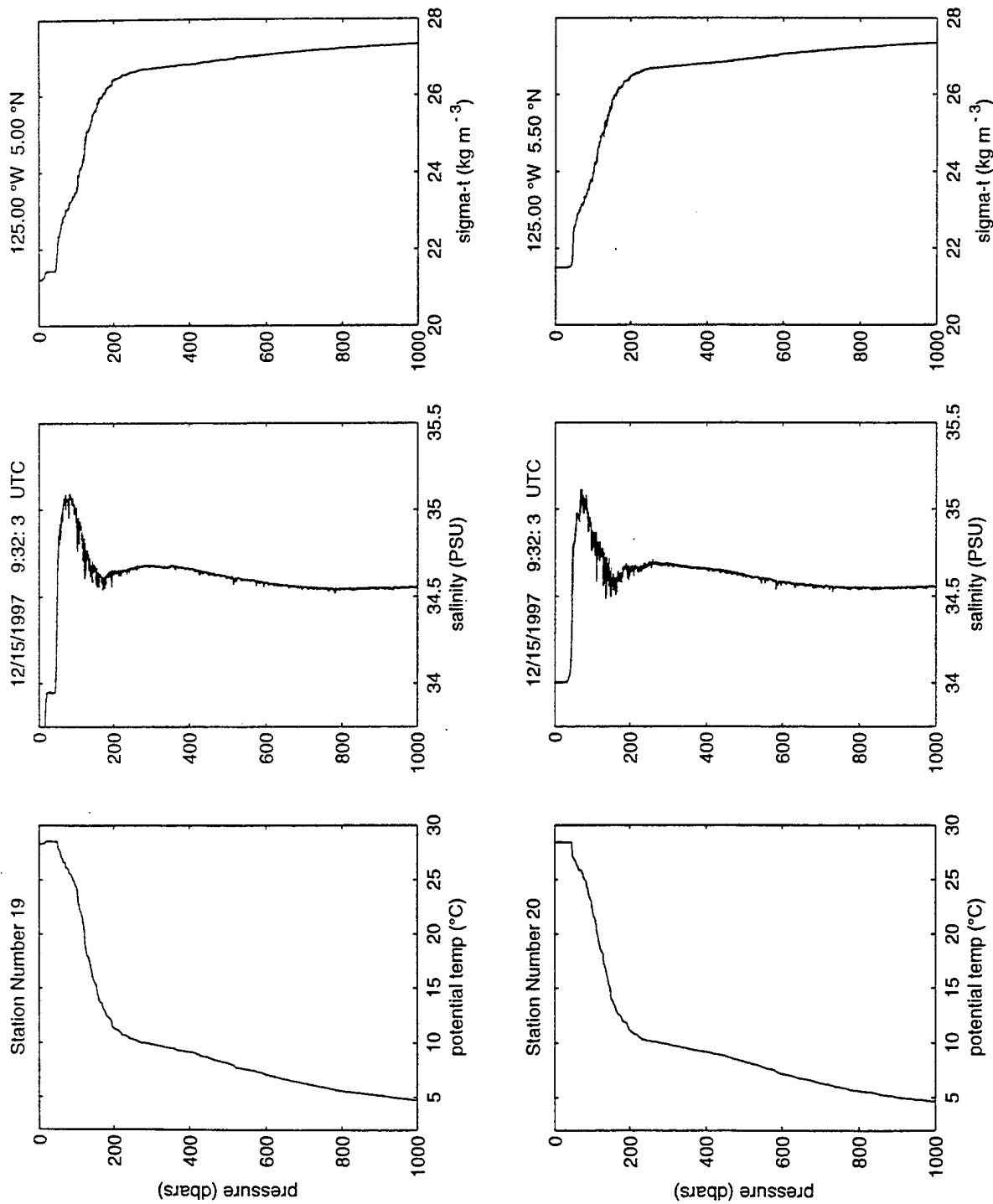

Figure A2-12: Profiles from CTD stations 19 and 20.

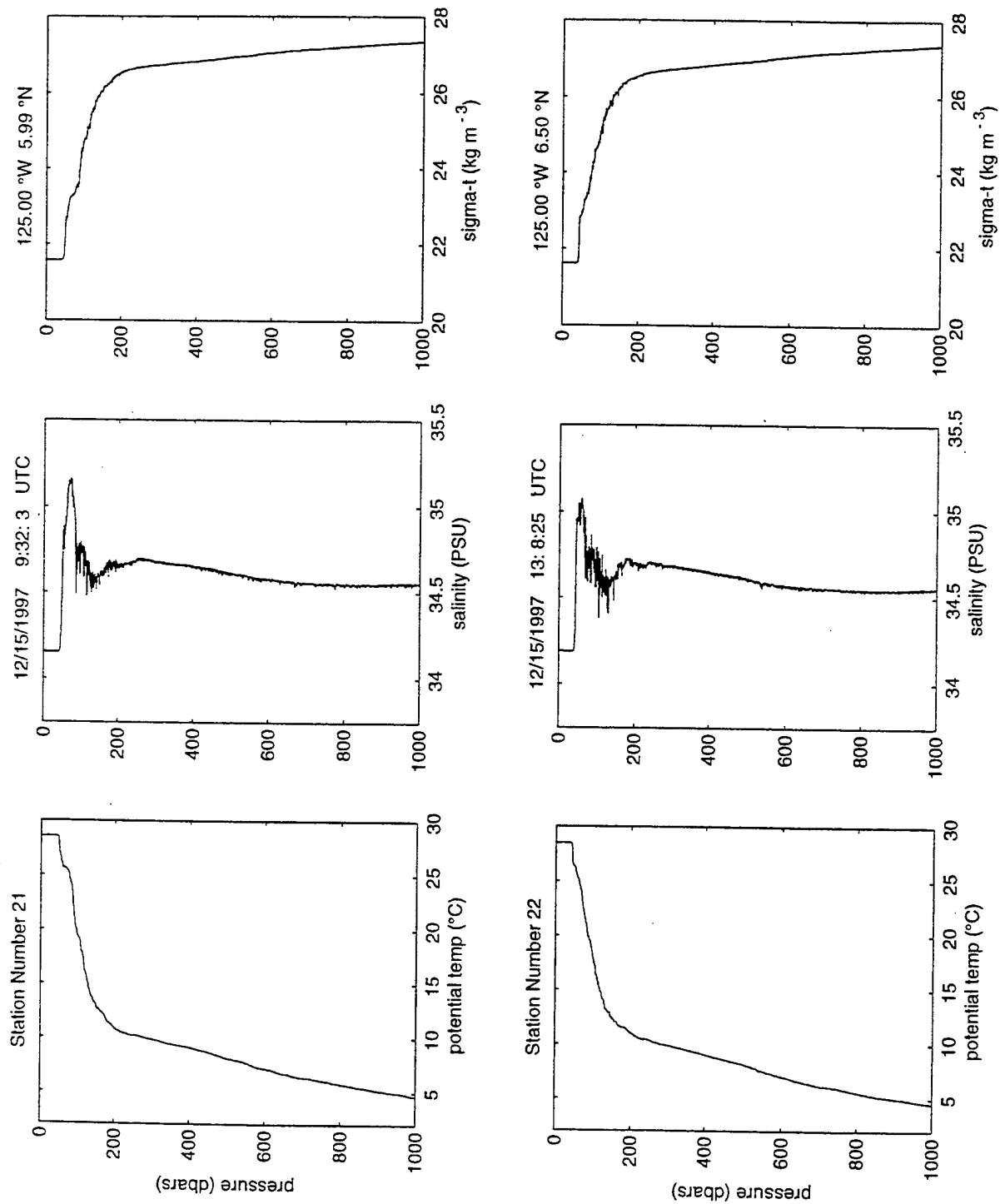

Figure A2-13: Profiles from CTD stations 21 and 22.

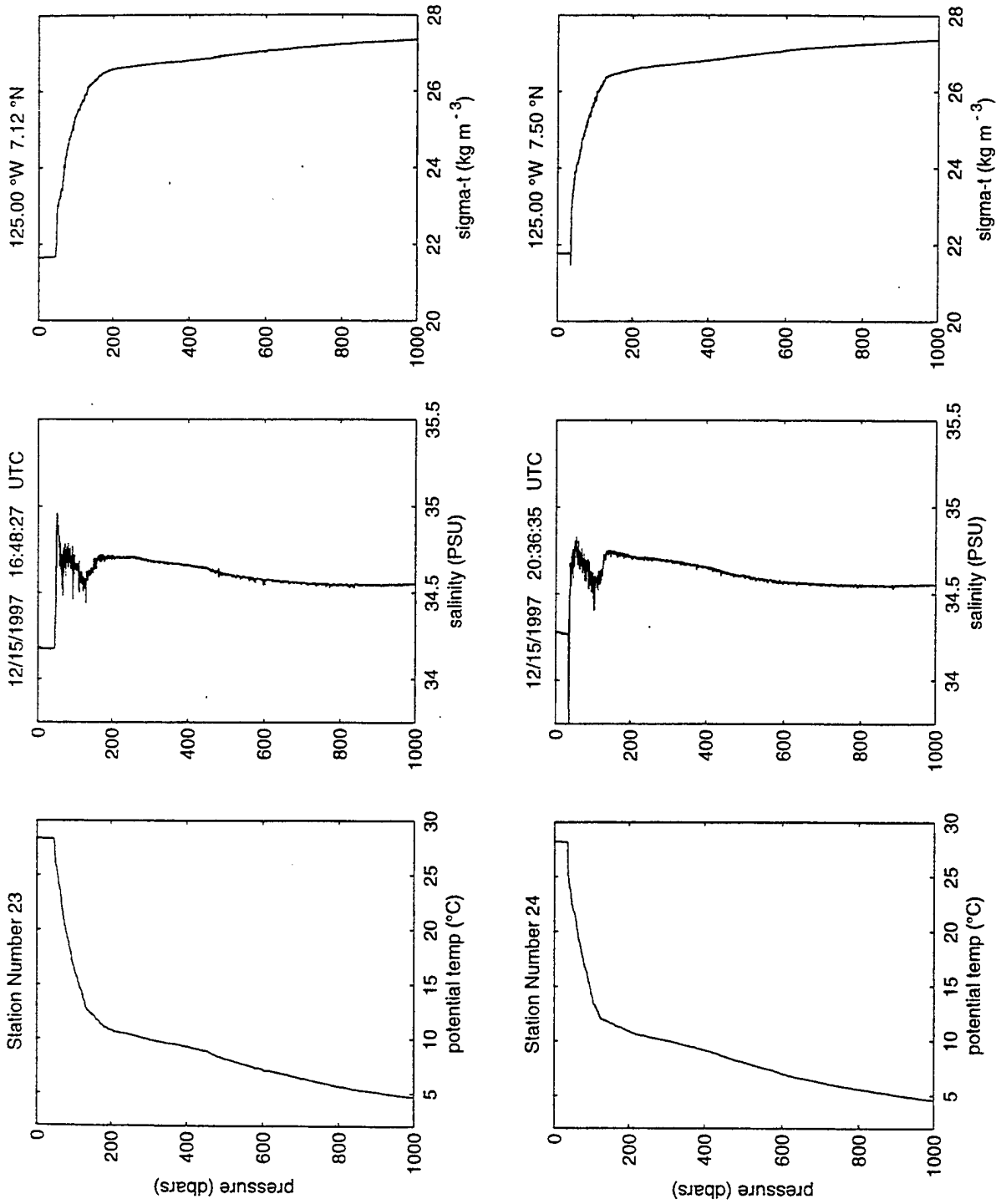

Figure A2-14: Profiles from CTD stations 23 and 24.

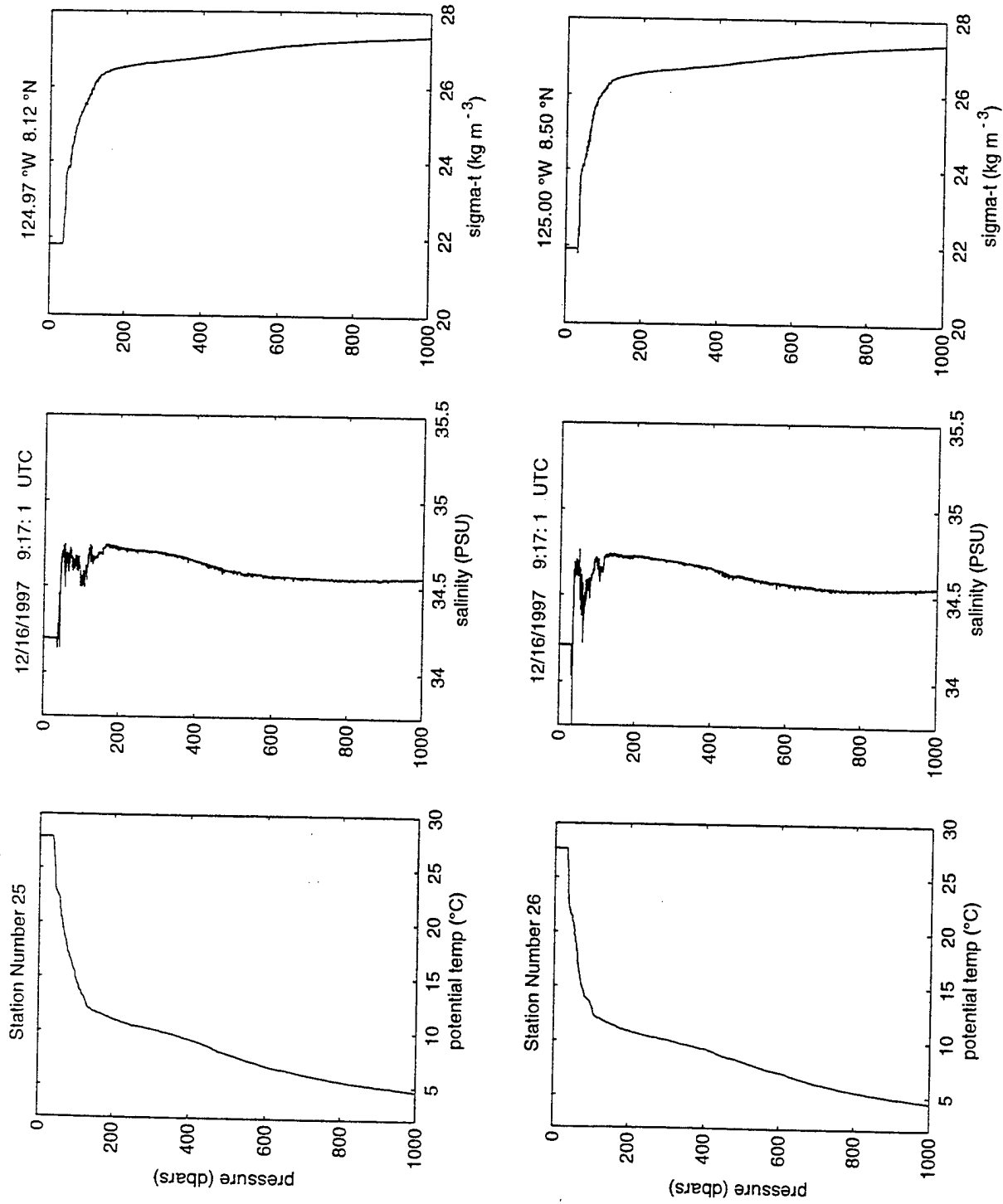

Figure A2-15: Profiles from CTD stations 25 and 26.

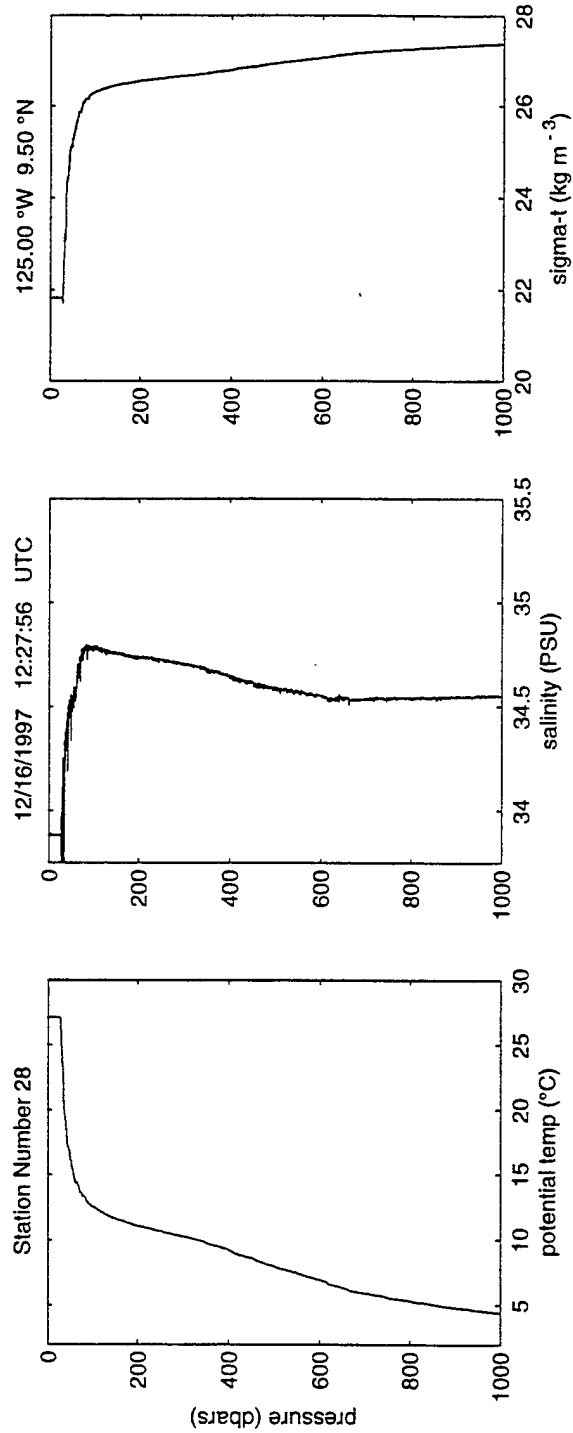
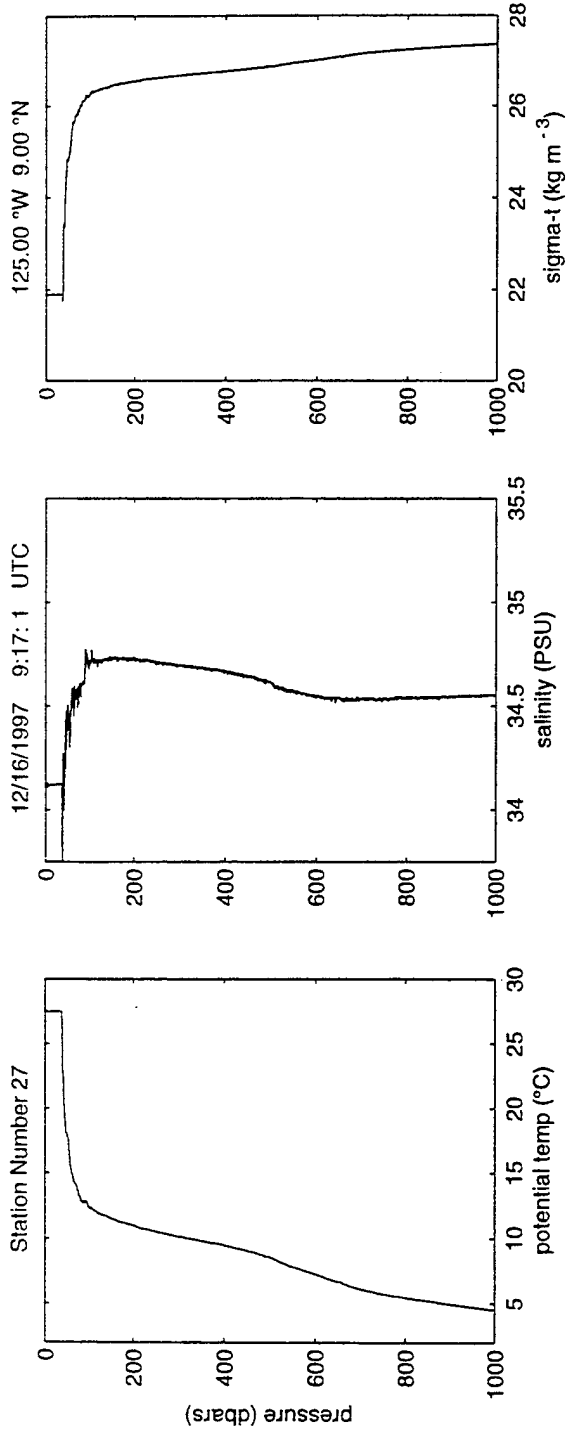

Figure A2-16: Profiles from CTD stations 27 and 28.

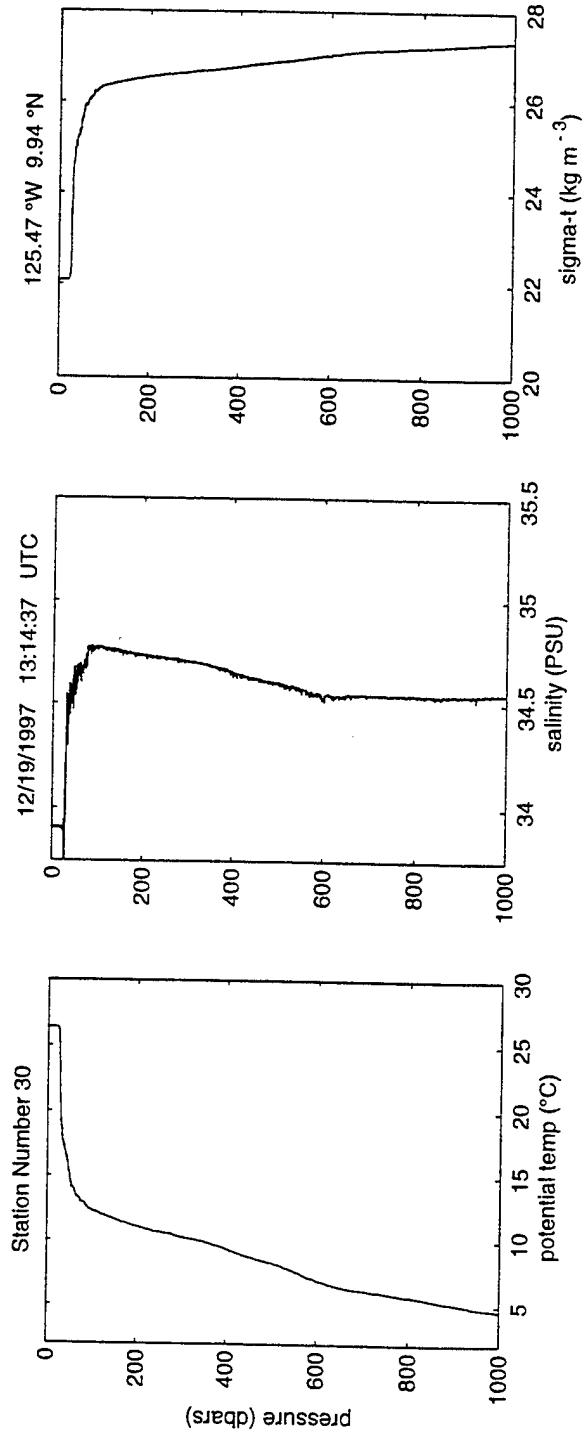
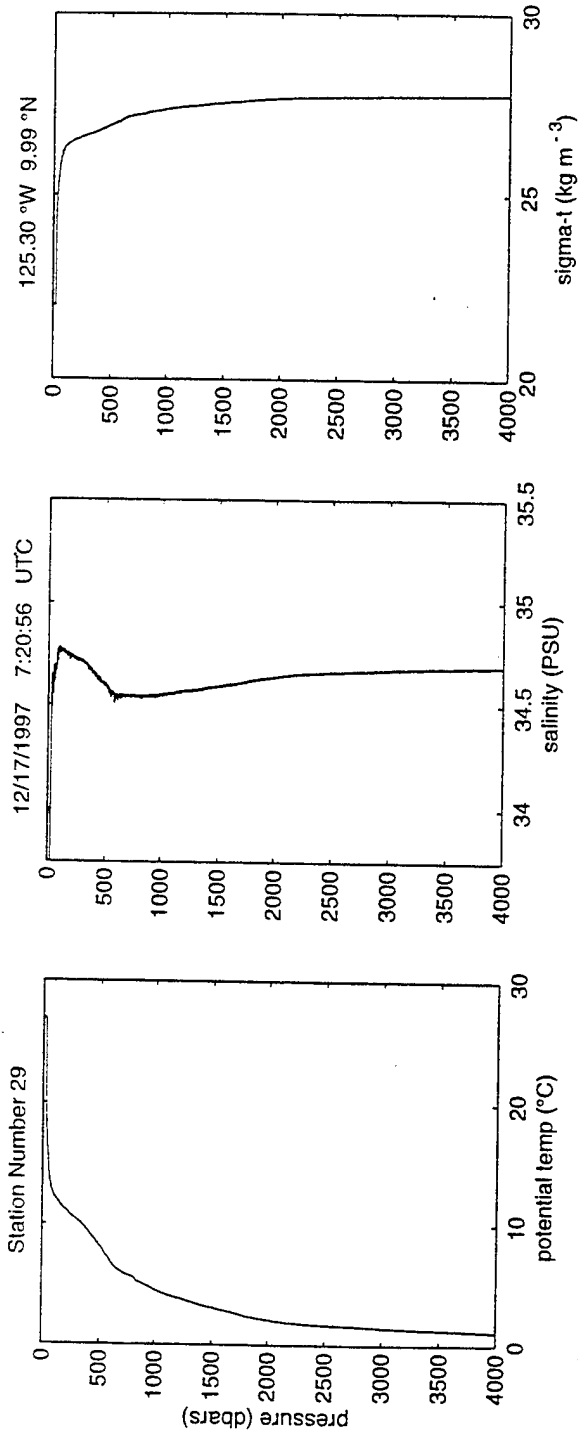

Figure A2-17: Profiles from CTD stations 29 and 30.

Appendix 3 Instrument Time Marks

Prior to and following the deployment of the moored instrumentation a time mark is put on the data record. In the case of the VMCMs this is done by rotor spins. The times of the rotor spins are recorded on the VMCM CMOI forms. The meteorological systems have a time mark applied to the data record by black bagging the short-wave radiation sensors and recording the time. The temperature recording instruments are placed in a cold bath and the time is recorded. The post-deployment time marks included here are for the PACS 1 South and North moorings. The pre-deployment time marks for the PACS 2 deployment are also included.

Post Cruise Time Mark PACS 1 South 9 Dec 97

Instrument	Time In, UTC	Time Out,UTC
Branckers		
3762	1622	1753
4489	1622	1753
3265	1623	1755
4492	1623	1756
3835	1624	1755
3283	1624	1754
3667	1625	1754
4485	1625	1754
4494	1626	1754
3279	1626	1753
3836	1627	1752
4482	1628	1752
3701	1640	1756
3699	1644	1755
3764	1645	1756
MTR		
3143	1630	1757
WaDaR		
274	1631	1757

SEACAT		
1430	1758	1840
993	1758	1840
929	1758	1840
991	1800	1841

MicroCAT		
0010	1758	1841

Post Cruise Time Mark
PACS 1 North
20 Dec 97

Instrument	Time In, UTC	Time Out, UTC
Brankers		
4494	1653	1810
3258	1653	1809
3309	1654	1809
4487	1654	1808
3259	1654	1808
3704	1655	1807
4491	1656	1808
3263	1656	1809
3703	1657	1806
4481	1657	1807
3838	1658	1806
3839	1658	1807
3662	1659	1806
3761	1659	1807
4483	1700	1806
MTR		
3240	1654	1810
WaDaR		
275	1700	1810
SEACAT		
928	1821	1846
992	1821	1846
994	1821	1846
MicroCAT		
009	1812	1846

Note: If there are any timing discrepancies for some of the above Branckers it may be due to their orientation in the cold bath. If a sensor was found out of the bath due to ship roll or a draining sink, the sensor was reimmersed. Time out of bath for all temperature loggers is accurate.

Pre Cruise Time Mark
 PACS Second Deployment (PACS2)
 19 Nov 97

Instrument	Time In UTC	Time Out UTC
Branckers		
2537	1820	1944
3508	1821	1943
4228	1821	1947
2535	1821	1944
3271	1821	1948
3291	1821	1948
3833	1821	1938
2533	1821	1944
3301	1821	1949
3296	1822	1948
3506	1822	1949
3702	1822	1949
3837	1822	1948
3274	1822	1947
3763	2104*	2227
4488	1822	1948
4402	1822	1940
3831	1823	1940
4486	1823	1939
2536	1823	1939
4493	2104*	2227
3308	1823	1939
3830	2104*	2227
2541	1823	1938
3834	1823	1939
3299	1823	1943
3507	1824	1949
MTR		
3241	1824	1909

4239	1824	1909
3246	1824	1909
3242	1824	1909

WaDaR

62	1824	1909
272	1908	1937
273	1908	1937

SEACAT

1882	1826	1904
1879	1829	1904
1878	1826	1904
146	1827	1907
1873	1827	1906
1874	1827	1902
1881	1828	1903
142	1828	1905
2322	1829	1905
141	1829	1906
927	1830	1902
1875	1830	1905
1876	1831	1901
1880	1831	1902
1877	1831	1903

MicroCAT

008	1832	1907
011	1832	1907

* More than one cold spike may be present. Time represents the last one on that date.

Appendix 4 WHOI Instrumentation Deployed during PACS 1 and 2

Vector Measuring Current Meters

Instrument	Deployment	Mooring	Depth (in meters)
VM-001	PACS 2	WHOI North	110
VM-002	PACS 2	WHOI North	90
VM-009	PACS 1	WHOI South	5
VM-010	PACS 2	WHOI North	20
VM-011	PACS 1	WHOI South	10
VM-012	PACS 2	WHOI North	70
VM-013	PACS 1	WHOI North	40
VM-014	PACS 1	WHOI North	15
VM-015	PACS 1	WHOI North	20
VM-016	PACS 1	WHOI North	5
VM-017	PACS 2	WHOI North	5
VM-018	PACS 1	WHOI South	70
VM-019	PACS 1	WHOI North	110
VM-020	PACS 1	WHOI North	10
VM-021	PACS 1	WHOI South	110
VM-022	PACS 2	WHOI South	30
VM-023	PACS 2	WHOI South	10
VM-025	PACS 1	WHOI South	40
VM-026	PACS 1	WHOI North	90
VM-027	PACS 2	WHOI North	40
VM-028	PACS 2	WHOI North	30
VM-030	PACS 2	WHOI South	90
VM-031	PACS 1	WHOI North	70
VM-032	PACS 1	WHOI South	50
VM-033	PACS 1	WHOI North	50
VM-034	PACS 2	WHOI South	70
VM-037	PACS 1	WHOI North	30
VM-038	PACS 1	WHOI South	20
VM-039	PACS 1	WHOI South	30
VM-040	PACS 2	WHOI South	110
VM-041	PACS 2	WHOI South	15
VM-043	PACS 2	WHOI South	20
VM-044	PACS 2	WHOI North	10
VM-045	PACS 2	WHOI South	5
VM-051	PACS 2	WHOI South	40
VM-052	PACS 2	WHOI North	90
VM-053	PACS 2	WHOI South	50
VM-055	PACS 2	WHOI North	15
VM-056	PACS 1	WHOI South	15
VM-201	PACS 2	WHOI South	130

Brancker Temperature Recorders

Instrument	Deployment	Mooring	Depth (meters)
2533	PACS 2	WHOI South	50
2535	PACS 2	WHOI North	35
2536	PACS 2	WHOI South	200
2537	PACS 2	WHOI North	60
2541	PACS 2	WHOI North	45
3258	PACS 1	WHOI North	1.50
3259	PACS 1	WHOI North	7.50
3263	PACS 1	WHOI North	0.25
3265	PACS 1	WHOI South	7.50
3279	PACS 1	WHOI South	35.00
3283	PACS 1	WHOI South	100
3299	PACS 2	WHOI South	100
3301	PACS 2	WHOI South	35
3309	PACS 1	WHOI North	45
3506	PACS 2	WHOI South	22.5
3507	PACS 2	WHOI South	25
3508	PACS 2	WHOI North	22.5
3662	PACS 1	WHOI North	150
3667	PACS 1	WHOI South	60
3699	PACS 1	WHOI South	0.50
3701	PACS 1	WHOI South	1
3701	PACS 2	WHOI North	100
3702	PACS 2	WHOI South	60
3703	PACS 1	WHOI North	25
3704	PACS 1	WHOI North	2.50
3761	PACS 1	WHOI North	35
3762	PACS 1	WHOI South	200
3763	PACS 2	WHOI South	12.5
3764	PACS 1	WHOI South	2.50
3764	PACS 2	WHOI North	150
3831	PACS 2	WHOI South	45
3835	PACS 1	WHOI South	0.25
3835	PACS 2	WHOI North	200
3836	PACS 1	WHOI South	7.50
3838	PACS 1	WHOI North	2
3839	PACS 1	WHOI North	200
4481	PACS 1	WHOI North	17.50
4482	PACS 1	WHOI South	150
4483*	PACS 1	WHOI South	45
4485*	PACS 1	WHOI North	1
4487	PACS 1	WHOI North	100
4488	PACS 2	WHOI North	12.5
4489	PACS 1	WHOI South	2
4491	PACS 1	WHOI North	0.50
4492	PACS 1	WHOI South	1.50
4493	PACS 2	WHOI North	25
4494	PACS 1	WHOI South	25
4495	PACS 1	WHOI North	60

* Brancker temperature logger number 4483 appears in the mooring log for mooring number 1015 (PACS 1 WHOI North) as having been deployed on the near surface temperature string at 1.00 meters depth. Brancker number 4485 appears in the mooring log of mooring number 1014 (PACS 1 WHOI South) as having been deployed at 45 meters depth. When the data was read from these instruments it was observed that data from instrument 4483 was included in a backup file with data from mooring 1014; and similarly data from 4485

was included with data from mooring 1015. A look at the data indicates that instrument 4485 has temperature data representative of the near-surface environment and instrument 4483 has data representative of 45 meters depth. The conclusion drawn from this is that the instrument numbers on the pressure cases were either misread or mislabelled resulting in the error in the mooring log. There is no confusion as to which data set belongs to which instrument since the data header automatically includes the instrument number. Therefore, it appears that instrument 4483 was deployed on mooring 1014 at 45 meters, and instrument 4485 was deployed on mooring 1015 at a nominal depth of 1.0 meters.

SEACAT temperature and conductivity recorders

<u>Instrument</u>	<u>Deployment</u>	<u>Mooring</u>	<u>Depth (meters)</u>
141	PACS 2	WHOI North	17.50
142	PACS 2	WHOI South	47.50
143	PACS 1	WHOI South	1.71
927	PACS 2	WHOI North	47.50
928	PACS 1	WHOI North	12.50
929	PACS 1	WHOI South	32.50
991	PACS 1	WHOI South	22.50
992	PACS 1	WHOI North	32.50
993	PACS 1	WHOI South	12.50
994	PACS 1	WHOI North	1.86
995*	PACS 1	WHOI North	22.50
1873	PACS 2	WHOI North	37.50
1874	PACS 2	WHOI South	7.50
1875	PACS 2	WHOI North	27.50
1876	PACS 2	WHOI South	37.50
1877	PACS 2	WHOI North	65
1878	PACS 2	WHOI South	17.50
1880	PACS 2	WHOI South	65
1881	PACS 2	WHOI North	7.50
1882	PACS 2	WHOI South	1.50
2322	PACS 2	WHOI North	1.50

* SEACAT 995 was lost at sea. Many of the PACS 1 North instruments were recovered with fish net entangled around them. The strength member that held instrument 995 was also recovered with fish net and it appears that the instrument may have been pulled from the strength member during attempts by a fishing vessel to free their nets.

MTRs

<u>Instrument</u>	<u>Deployment</u>	<u>Mooring</u>	<u>Depth</u>
3240	PACS 1	WHOI North	3.5
3241	PACS 2	WHOI North	3.5
3242	PACS 2	WHOI South	3.5
3243	PACS 1	WHOI South	3.5

WaDaR

<u>Instrument</u>	<u>Deployment</u>	<u>Mooring</u>	<u>Depth</u>
272	PACS 2	WHOI North	Surface
273	PACS 2	WHOI South	Surface
274	PACS 1	WHOI South	Surface
275	PACS 1	WHOI North	Surface

MicroCATs

Instrument	Deployment	Mooring	Depth
008	PACS 2	WHOI South	80
009	PACS 1	WHOI North	80
010	PACS 1	WHOI South	80
011	PACS 2	WHOI North	80

CHLAM

Instrument	Deployment	Mooring	Depth
ACH0126	PACS 1	WHOI South	27.5

FSI current meter

Instrument	Deployment	Mooring	Depth
1428A	PACS 1	WHOI South	130

SHERMAN current meter

Instrument	Deployment	Mooring	Depth
002	PACS 1	WHOI South	120
001	PACS 2	WHOI South	120

Acoustic rain gauge

Instrument	Deployment	Mooring	Depth
002	PACS 1	WHOI North	29

Bio-optical package

Instrument	Deployment	Mooring	Depth
000	PACS 2	WHOI South	27.5

Appendix 5

Wind Direction Sensor Comparison Tests

Part of the preparation of the meteorological packages includes checking the wind direction sensors. This consists of placing each buoy on a pallet that can be rotated through 360° and directing the wind vane to a fixed target at 60° intervals. The direction is then computed from the instrument compass and vane direction data. This procedure was followed both in Woods Hole prior to shipping and again in Hawaii on the dock prior to loading the buoys on the ship.

The test site in Woods Hole was located at the southern corner of the Clark South Laboratory parking area. This site showed little horizontal or vertical spatial variation in the magnetic field. The buoys were mounted, each in turn, on a large wooden pallet that could be rotated and the direction of a tree near the Clark building was measured from six buoy orientations. At each of the six positions the wind vane was aligned to the tree by eye and locked in position. The data were then read directly from the instrument. In the case of the VAWR, the compass and vane positions are added to obtain the wind vane direction in oceanographic convention (i.e., the wind direction of flow from the north is 180°.) The magnetic bearing to the tree from the test site was 309°.

A test site was chosen at the University of Hawaii Marine Center based on proximity to overhead wiring, steel shipping containers, and a brief survey of the area. By sighting on a distant light pole in clear view from several lateral positions, an area with small magnetic field gradients was identified. The direction checks conducted in Hawaii were intended to identify any gross problems that might have occurred in the instrumentation during shipping and should not be considered a calibration since careful site selection was not possible. The magnetic bearing to the distant object sited in Hawaii was 158°.

Figures A5-1 and A5-2 show the direction comparison tests that were conducted in Woods Hole. Figures A5-3 and A5-4 are the results of direction comparison tests conducted at the University of Hawaii Marine Center dock.

PACS 2 North Buoy Spin

24 September 1997

Woods Hole Oceanographic Institution

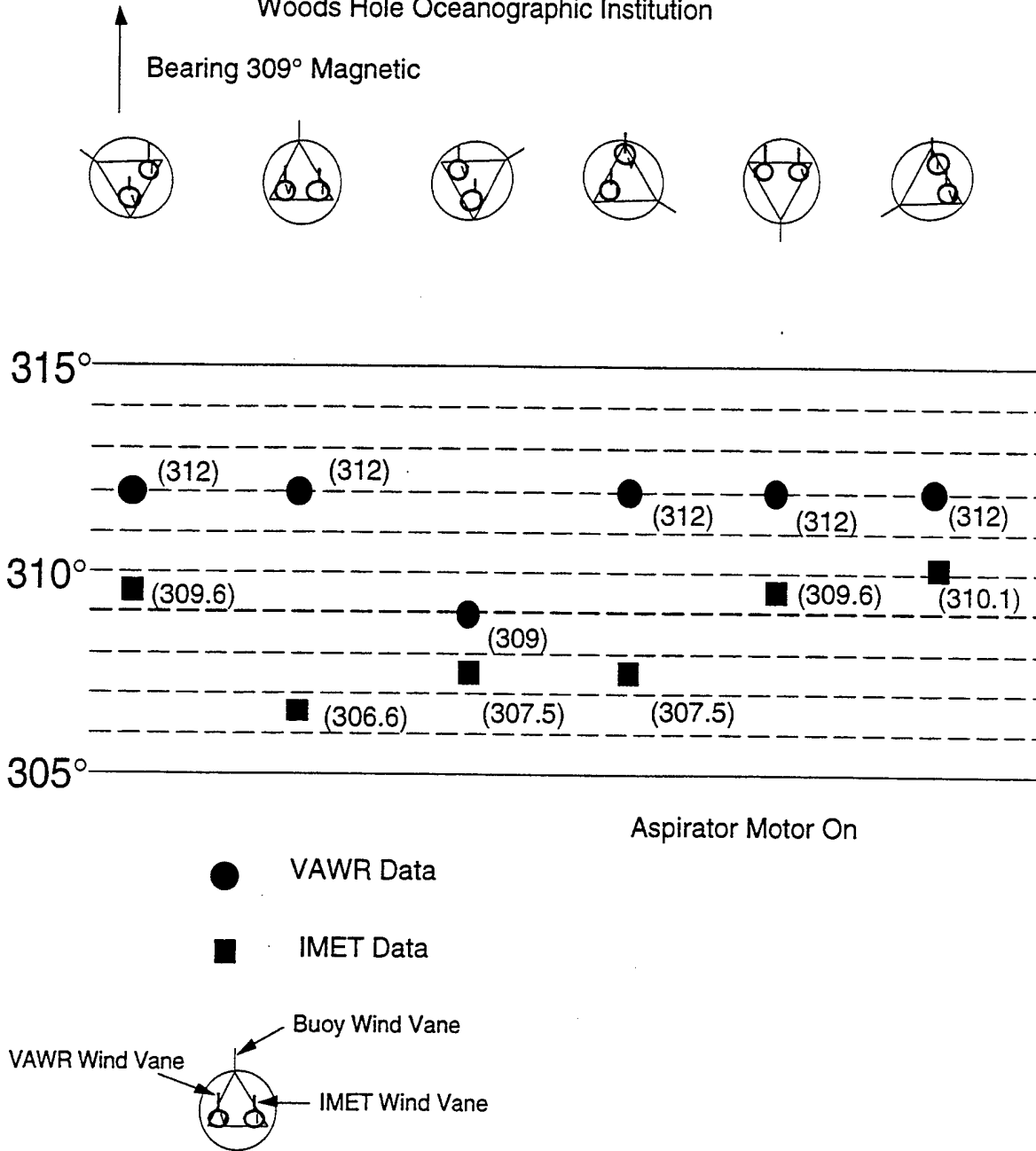

Figure A5-1: Wind direction comparison tests, PACS 2 North.

PACS 2 South Buoy Spin

24 September 1997

Woods Hole Oceanographic Institution

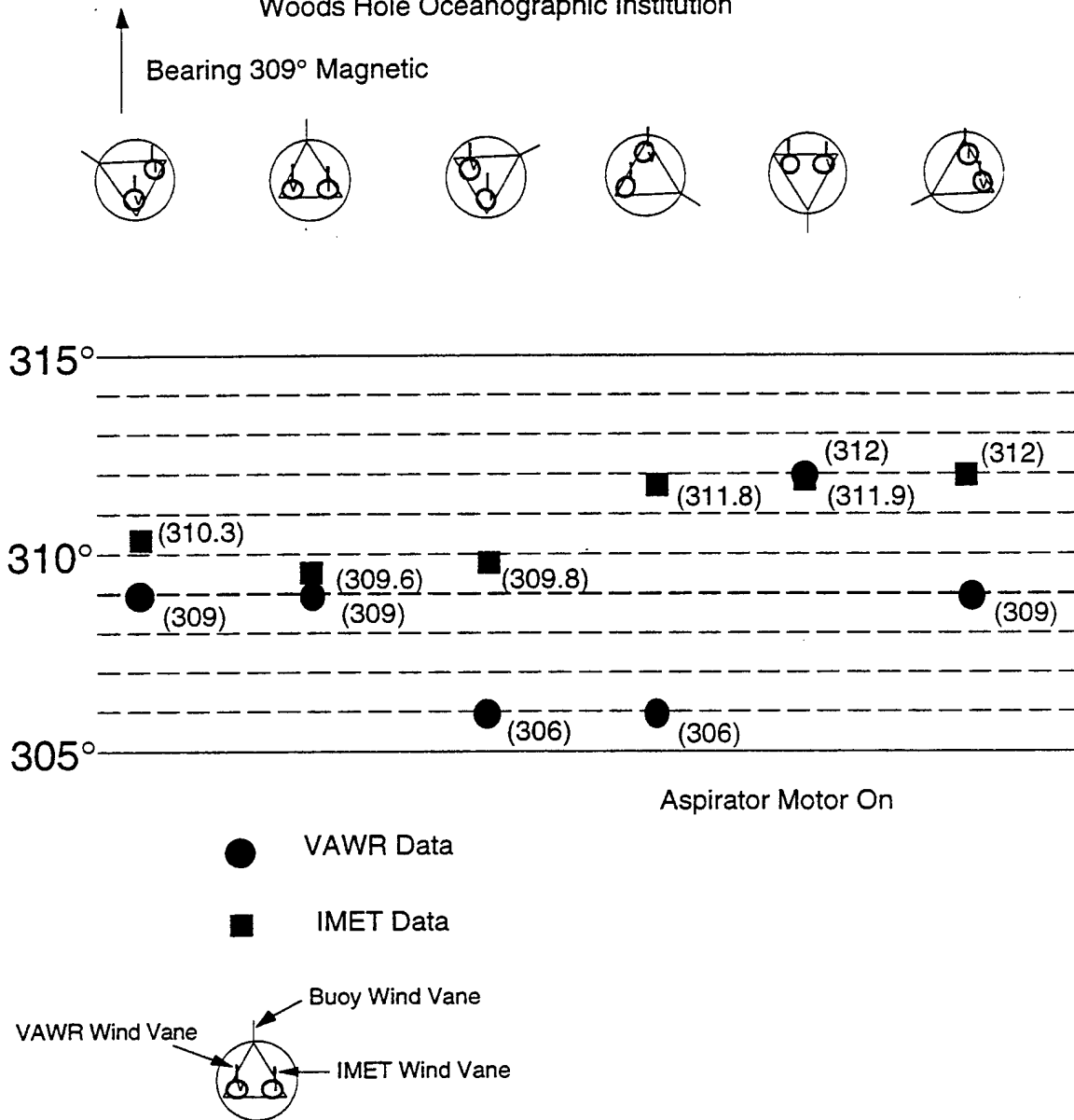

Figure A5-2: Wind direction comparison tests, PACS 2 South.

PACS 2 North Buoy Spin

20 November 1997

University of Hawaii Marine Center Dock

Bearing 158° Magnetic

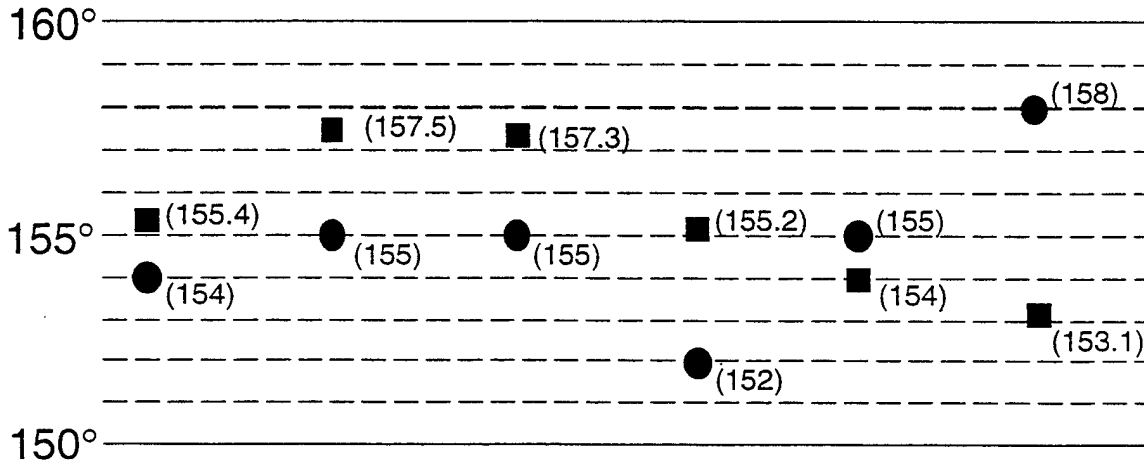
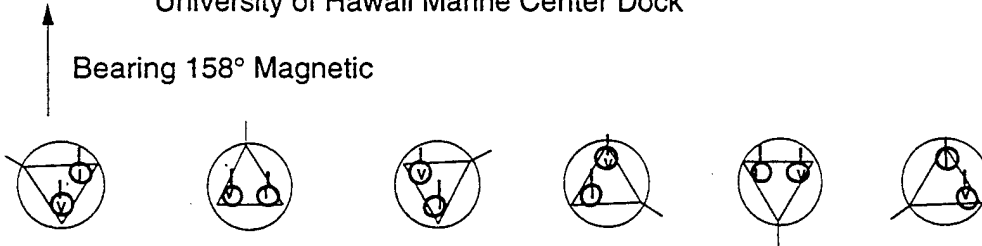

● VAWR Data

■ IMET Data

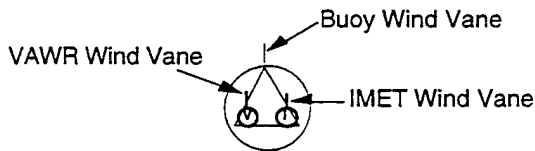

Figure A5-3: Wind comparison tests (Hawaii), PACS 2 North.

PACS 2 South Buoy Spin

21 November 1997

University of Hawaii Marine Center Dock

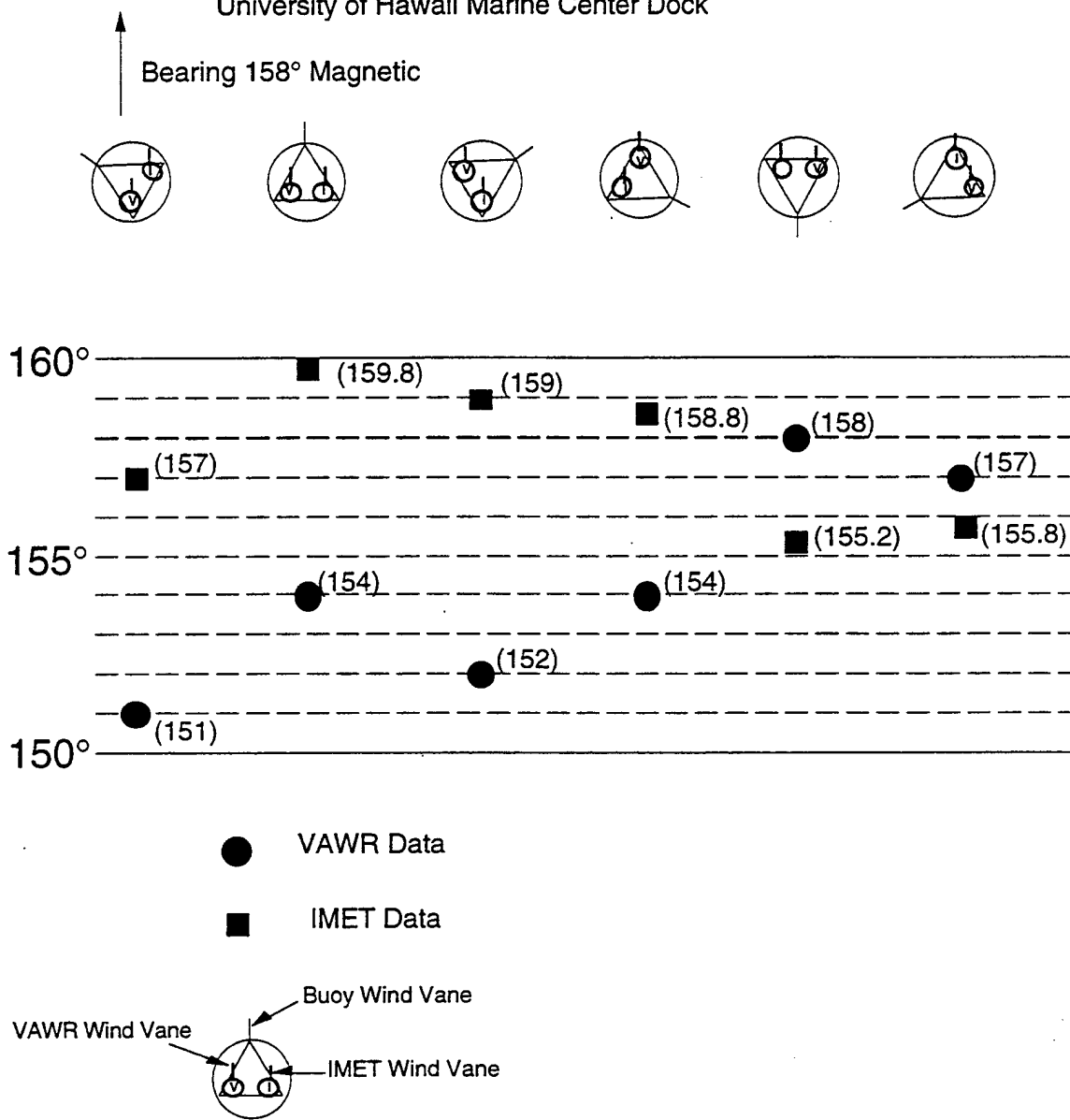

Figure A5-4: Wind comparison tests (Hawaii), PACS 2 South.

Appendix 6 VMCM Record Format

1. RECORD COUNTER (TIME)

The first 16 bits (four characters) of data comprise the record number. The counter is incremented once each data record. The first record number is one (0001) and is used to initialize the instrument. The data and length of the first record may be invalid and should be ignored. Record two (0002) contains data for the first record interval. After 65535 records, the record counter will reset to zero and begin its normal counting.

2. NORTH VECTOR

Each vector is scaled from a 24-bit accumulator and stored in a 16-bit floating-point representation. This vector is the algebraic sum of the NORTH component of current flow from each sample.

3. EAST VECTOR

Each vector is scaled from a 24-bit accumulator and stored in a 16-bit floating-point representation. This vector is the algebraic sum of the EAST component of current flow from each sample.

4. ROTOR 2 (X CURRENT FLOW) (UPPER)

The rotor counts are an algebraic sum of the counts for a record interval. Rotor counts are scaled from a 24-bit accumulator and stored as a 16-bit floating number.

5. ROTOR 1 (Y CURRENT FLOW) (LOWER)

The rotor counts are an algebraic sum of the counts for a record interval. Rotor counts are scaled from a 24-bit accumulator and stored as a 16-bit floating number.

6. COMPASS

The compass field is an 8 bit 2's complement number (-128 to +128 decimal). The stored value is measured at the beginning of the last sample of the record interval.

7. TEMPERATURE

One temperature sample is taken at the beginning of each record interval.

Record interval = 2 seconds to 2 hours

Sample interval = .25 seconds to 2 seconds in quarter second steps

PREAMBLE/ TIME/ NORTH/ EAST/ R2/ R1/ COMPASS/ TEMP./ PARITY
(2) (4) (4) (4) (4) (4) (2) (4) (1)

(X) = Number of characters

Appendix 7 Dragging Operations

Following the deployment of the USF PACS 2 mooring anchor, visual and radar contact with the surface buoy was lost during a passing squall. After the squall passed and the buoy remained unaccounted for on radar, the acoustic releases were interrogated for attitude and were found to be in the horizontal rather than the vertical position. A release survey was performed giving an anchor location of $00^{\circ} 00.36'N$, $127^{\circ} 57.96'W$, approximately 0.2 nautical miles east of the anchor drop position and about 0.4 nautical miles west, north west of the last buoy sighting. All of the positions were consistent with the deployment geometry. In view of the possibility that the buoy may have broken loose and was still on the surface, a search pattern was run throughout the evening beginning at 0320 UTC, December 12, 1997. The ship then transited across the anchor survey position with the Hydrosweep at 1340 UTC in an attempt to locate any mid-water reflections, but without success. A response from Service Argos was received to a fax inquiry regarding the last fix transmitted from the buoy. This confirmed that the buoy had submerged.

The decision to drag for the USF surface mooring was made at approximately 1620 UTC on December 12, 1997. The strategy was to drag the trawl wire and grapnels perpendicular to a line that ran from the surveyed anchor position to the last visual/radar contact with the buoy. We would start laying trawl wire on the bottom at a position designated as the wire touch down position) that was .25 miles to the north of the line. Figure A7-1 schematically shows the dragging strategy employed during TN 073.

Prior to starting the dragging operation a release command was sent at 1805 UTC to disconnect the mooring from its anchor. Repeated ranging on the release showed no appreciable movement of the release.

Dragging gear provided by WHOI consisted of two large grapnels; two 500-pound depressor weights; miscellaneous swivels and a shot of sacrificial trawl wire approximately 300 meters long. The grapnels and depressor weights were attached to the sacrificial shot, which was the primary length of wire that was dragged along the bottom. The use of a sacrificial shot of wire minimizes the amount of ship's trawl wire that is in contact with the bottom. The ship was positioned two miles to the northeast of the proposed wire touch down position and began lowering the bottom depressor weight and sacrificial wire shot while the ship steamed at .3 knots to the south.

The thought was that the ship would be set to the west and would end up at the wire touch down location just as the wire reached the bottom. Two grapnels were attached to the sacrificial wire shot along with a 500-pound depressor weight at the junction between the ship's trawl wire and the sacrificial shot. Fifty meters above that junction there was a 12kHz Benthos pinger and 50 meters above the pinger was one of the University of South Florida's model 8202 acoustic releases. Figure A7-2 illustrates the configuration of the trawl wire. The height of the pinger off the bottom was monitored using the ship's Raytheon PDR. After attaching the grapnels and instrumentation, the trawl wire was lowered at 50 meters per minute.

The ship reached the wire touch down position just as the wire began to lay on the bottom. As the pinger approached the bottom, the payout rate was adjusted to keep the pinger no more than 50 meters off the bottom. By maintaining a pinger height of between 30 to 50 meters off the bottom, we were confident that the grapnel hooks would stay on the

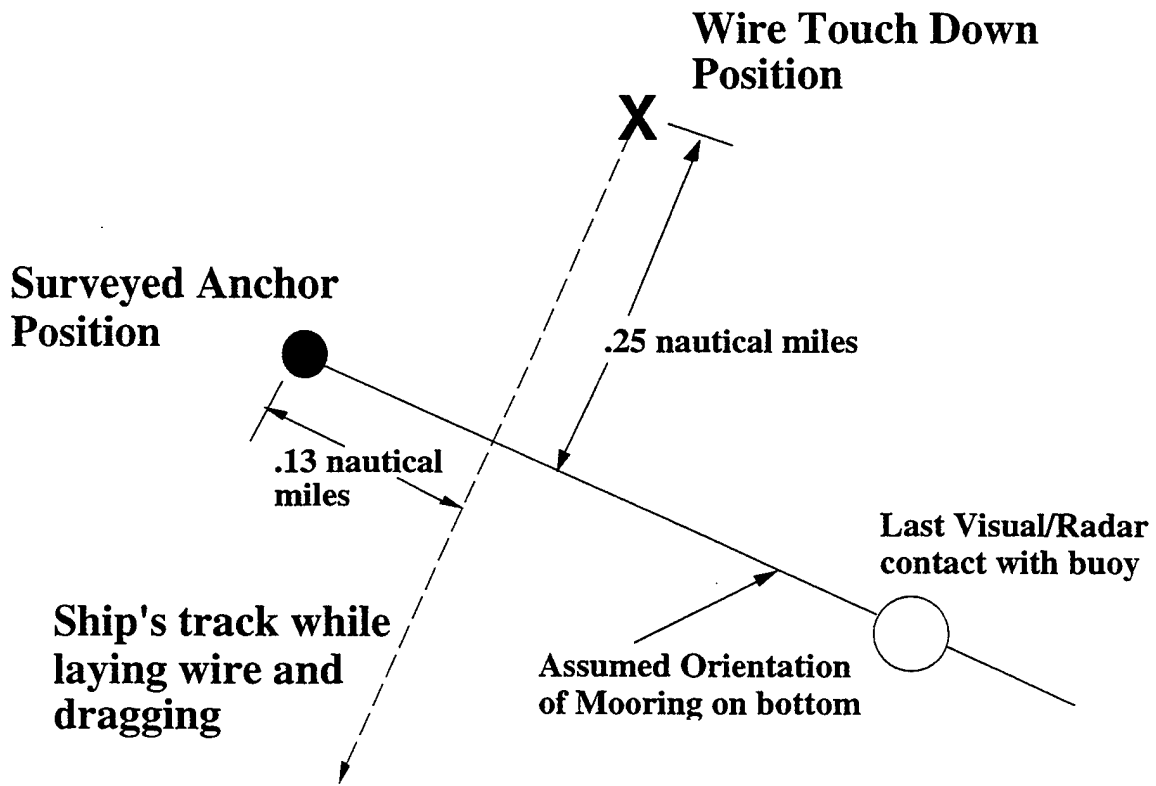

Figure A7-1: Schematic of dragging strategy during TN 073.

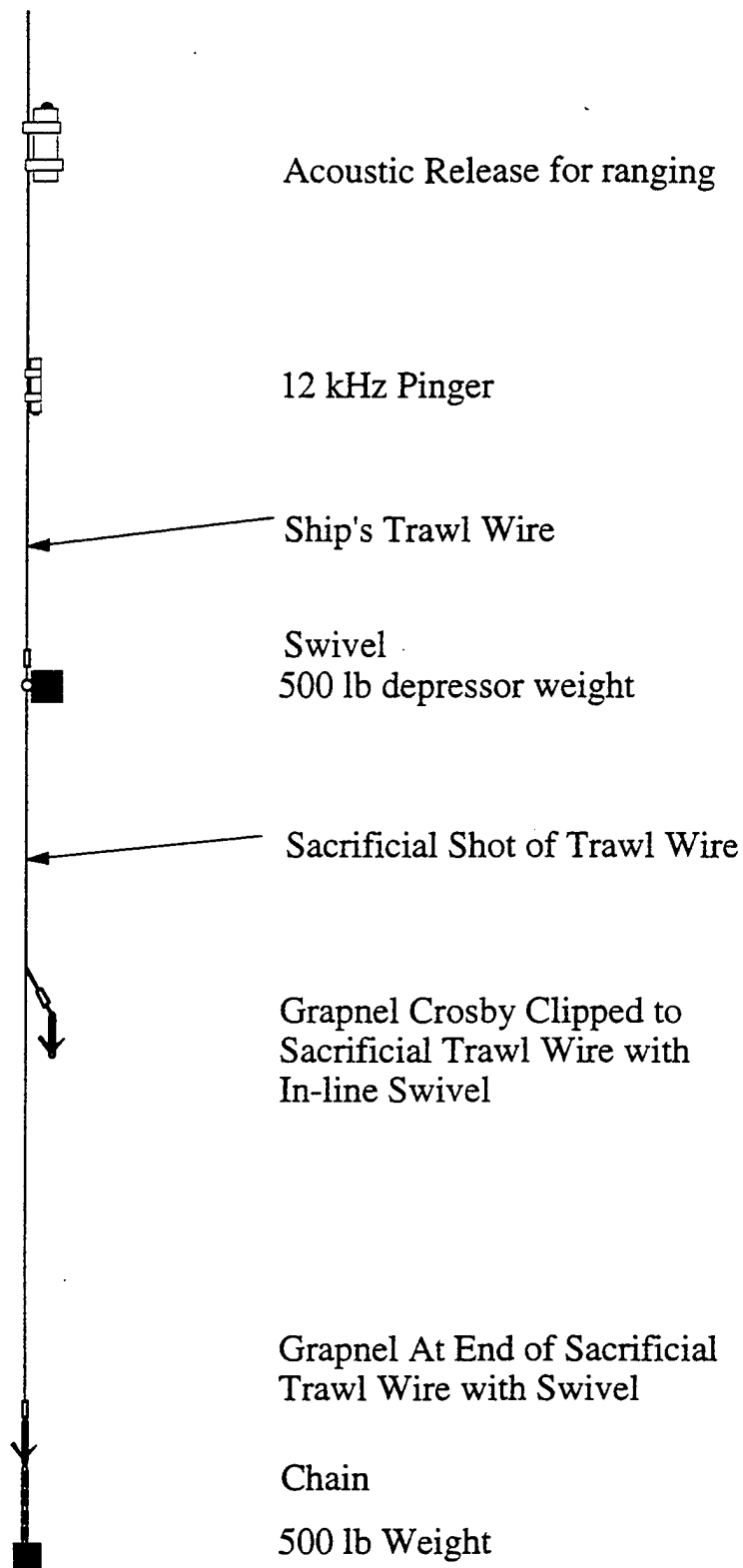

Figure A7-2: Trawl wire configuration during dragging operations.

bottom and engage any mooring components in their path. Payout at rates that varied between 5 meters and 15 meters per minute continued as the ship steamed past the anchor position. The ship steamed a course of 207° at approximately one knot. At 2355 UTC the ship stopped and a range to the acoustic release on the trawl wire was obtained. The range indicated that the grapnels were just beginning to cross the imaginary line between the anchor and the last visual sighting of the buoy. The ship then continued on the same course for another 30 minutes so that the hooks would be well past the mooring anchor position. At 0040 UTC the ship was 2.35 miles from the mooring anchor with 6320 meters of wire out. At 0050 UTC the ship stopped and again tried to range on the release but received ambiguous results. We then began to rehaul the trawl wire at 20 meters per minute. At 0554 UTC the uppermost depressor weight came onboard with nylon line bent around the weight and a nylon termination in sight. The nylon line was stopped off and the remainder of the dragging gear was recovered. All of the dragging equipment was on board by 0753 UTC and by 1218 UTC the entire mooring had been recovered.

Of the instruments deployed only the acoustic releases and the Sea-Bird MicroCATs had pressure cases rated to the water depth. All other instruments were destroyed. The 150 kHz ADCP was crushed and its lithium batteries were burned; the 300 kHz Workhorse ADCP was missing; the WaDaR temperature recorders were crushed although the three with electronics still attached had their lithium batteries intact as were the lithium batteries on the imploded Argos transmitter. The buoy did not gain positive buoyancy until approximately 30 meters from the surface. When brought onboard it was evident that the buoy had been seriously deformed from the pressure.

Appendix 8

Mooring Deployment Operations

The PACS North and South surface moorings deployed from the *Thompson* were set using the UOP two-phase mooring technique. Phase 1 involved the lowering of approximately 40 meters of instrumentation over the port side of the ship; and phase 2, the deployment of the buoy into the sea. The benefits from lowering the first 40 meters of instrumentation is three fold: (1) It allows for the controlled lowering of the upper instrumentation; (2) the suspended instrumentation, attached to the buoy's bridle, acts as a sea anchor to stabilize the buoy during the deployment of the buoy; and (3) the 80-meters length of paid-out mooring wire provides adequate scope for the buoy to clear the stern without capsizing or hitting the ship.

The mooring gear used in the deployment of the surface moorings included: the Lebus winch system; the crane on the 01-deck; the HIAB crane; Yale grips; and the standard complement of chain grabs, stopper and slip lines. Figure A8-1 shows the location of various pieces of deck equipment utilized during mooring operations on TN 073.

Phase 1: Launching the upper instrumentation

The personnel utilized during the first phase of the operation included: a deck supervisor; three Lebus winch operators; four mooring wire handlers, a crane-whip operator; an HIAB crane operator and a crane operator on the 01-deck. Figure A8-2 illustrates the positioning of personnel during the instrument lowering phase.

For this narrative the PACS 2 South mooring (figure 6) is used to describe the deployment procedures utilized for both the North and South WHOI moorings. Prior to the deployment of the southern mooring, a 150-meter length of 3/8" diameter wire rope was measured; and four Yale grips were woven at 31 meters, 36 meters, 41 meters and 46 meters from the swage fitting. (Yale grips are a multi-strand Kevlar eye splice that can be spliced mid-span onto wire or line.) The grips provide the wire handler at the rail a better holding point on the hauling wire during the instrument lowering phase of the deployment. This wire shot, or hauling wire, was pre-wound onto a wooden reel, with Yale grips on top of the reel. The reel was secured to the Lebus spooler and the bitter end of the wire paid out and reeved with five wraps around the Lebus capstan winch. The hauling wire, (Figure A8-2), was then paid out to allow its bitter end to be passed out through the center of the A-frame, around the aft port quarter and up forward along the port rail to the instrument lowering area.

The four hauling wire handlers were positioned around the aft port rail. Their positions were in front of the Lebus capstan; the center of the A-frame; aft port quarter; and approximately 8 meters forward along the port rail. The job of the wire handlers was to keep the hauling wire from fouling in the ship's propellers.

The HIAB crane, located on the port side of the fantail, was used as an outrigger hooking the last Yale grip to a Release-A-Matic quick release hook, which was secured to the HIAB boom. The crane's boom was articulated so that it would reach 15 feet over the port aft quarter. The port aft quarter wire handler was responsible for attaching the last Yale grip to the hook and releasing this grip and hauling wire once the discus had been deployed and had drifted clear of the ship's propellers.

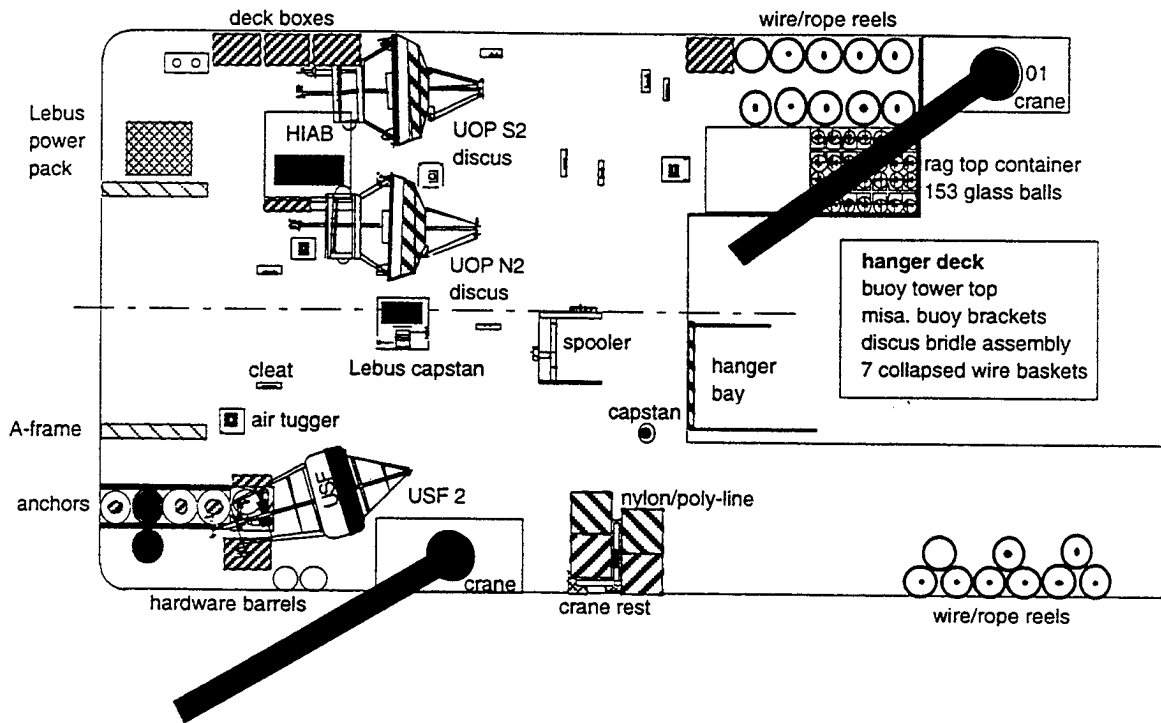

PACS II departure deck layout
scale 1" = 15'

Science Gear Weights	
6	deck box 5800 lbs.
2	USF anchor 9000 lbs.
3	UOP anchor 27900 lbs.
1	USF toriod 2500 lbs.
2	UOP discus 5400 lbs.
1	Lebus power pack 4500 lbs.
1	Lebus capstan 4900 lbs.
1	Lebus spooler 2000 lbs.
35	wire/nylon reels 7000 lbs.
4	air tuggers 900 lbs.
153	glass balls & van 20600 lbs.
1	dragging gear 2000 lbs.

Figure A8-1: Deck layout, TN 073

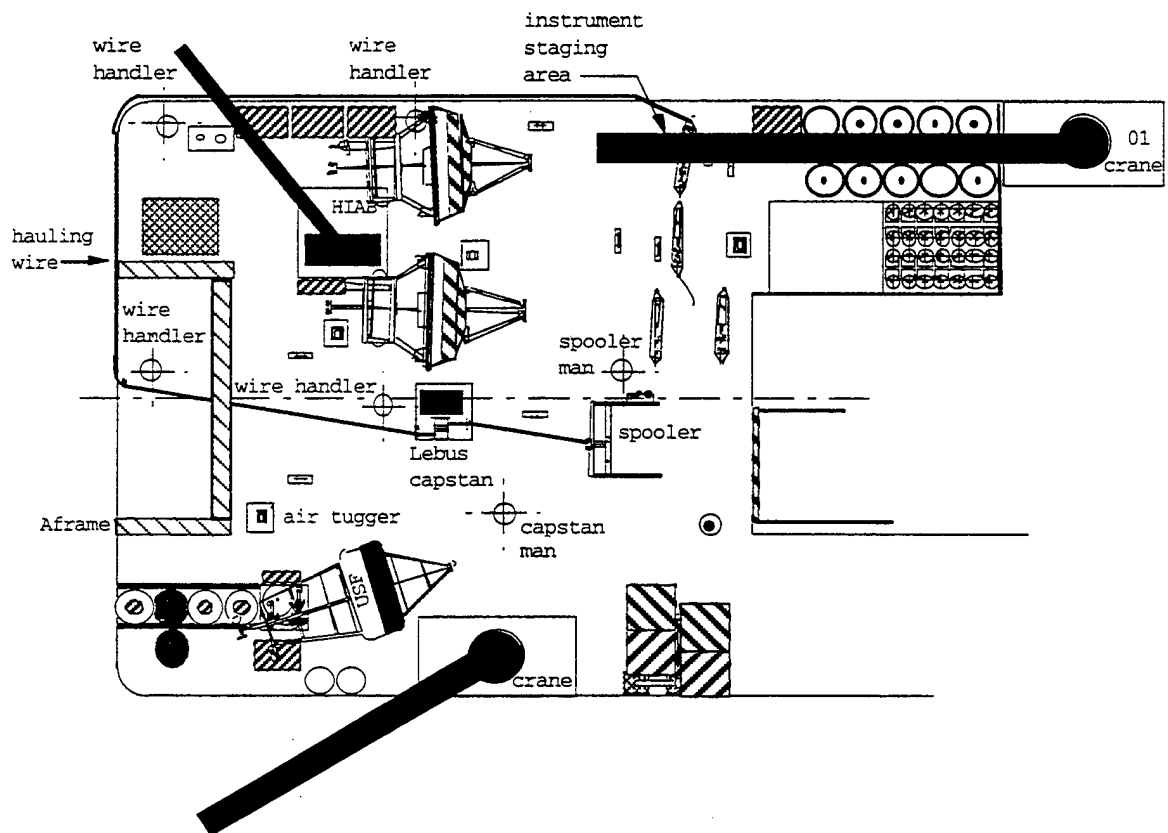

Figure A8-2: Personnel positioning, lowering phase surface mooring deployment.

Prior to the start of the operation, the ship's bow was positioned up wind with minimal way during the instrument lowering phase. The 01-crane was extended out so that there was a minimum of 10 meters of free whip hanging over the instrument lowering area.

The Lebus winch was operated by three operators--capstan, slue, and spooler. Their duties entailed the paying out of the hauling wire at a similar speed to that of the crane's whip on the 01-deck level. The instrument lowering commenced by shackling the bitter end of the hauling wire to the 5.3-meter length of 7/16" wire rope. The free end of wire rope was then shackled to the bottom of the 40-meter VMCM. A .76-meter shot of 3/4" chain, 37.5-meter SEACAT, 45-meter Brancker temperature recorder and 5.3-meter shot of 7/16" wire rope were connected to the top of the 40-meter VMCM. The crane whip was hooked to the top of this wire shot using a Lift-All sling which was reveed through the end link shackled to the end of the wire rope. This was done with the 01-crane in the extended position. The crane whip then raised the wire and attached instrumentation until the entire length was vertical and approximately .5 meters off the deck. The crane operator was instructed to swing outboard one meter to clear the ship's side and slowly lowered its whip and attached mooring components down into the water. The Lebus winch simultaneously paid out the hauling wire. The wire handlers positioned around the stern tended the hauling wire, easing it over the port side and allowing only enough wire over the side to keep the lowered mooring segment vertical in the water. When the top of the wire shot was .5 meters off the deck, the crane was then directed to swing slightly inboard. An Ingersal Rand, 1000-pound line-pull air tugger was used to stop off the wire shot. Then a stopper line with a Renfro snap hook was hooked into the end link shackled to the bitter end of the wire shot and secured to a deck cleat. The whip was then lowered, transferring the tension to the stopper line and removed.

The next instruments to be lowered were brought into the instrument staging area with their bottom ends pointing outboard so that the bottom ends could be shackled in series to the top of the stopped off wire shot. On this segment of the mooring were the 30-meter VMCM; Bio-Optic Package; and the 25-meter and 22.5-meter Brancker temperature recorders clamped to a 5.3-meter shot of 7/16" wire rope. The bottom end of the 30-meter VMCM was shackled onto the stopped-off end link. The loose end of the wire, fitted with a 3/4" chain shackle and 7/8" end link, was again hooked onto the crane whip using a sling. The crane whip was taken up into a vertical position .5 meters off the deck, and with it the wire and instruments. Once the crane's whip had taken the load of the mooring components, the stopper line was slackened and removed. The crane was then swung outboard and the whip lowered. The Lebus winch slowly paid out the hauling wire

The operation of lowering the upper mooring components in conjunction with the pay out of the hauling wire was repeated up to the upper .4-meter shot which was shackled to the MTR temperature logger. At this point the chain segment attached to the MTR was stopped off to the deck with a chain grab leaving enough slack in the assembly to be shackled to the discus universal joint attached to the bridle.

At this point in the deployment the last Yale grip was hooked into a quick release hook which was hung from the HIAB crane boom. The crane then extended outboard over the aft port rail keeping the hauling wire well away from the side of the ship.

Phase 2: Launching the discus buoy

The second phase of the operation was the launching of the discus buoy. There were three slip lines rigged on the discus to maintain constant swing control during the lift. The three slip lines were positioned through the bridle, the tower bail, and a buoy deck bail (Figure A8-3). The 30-foot bridle slip line was used to stabilize the bridle and allow the hull to pivot on the bridle's apex at the start of the lift. The 60-foot tower slip line was

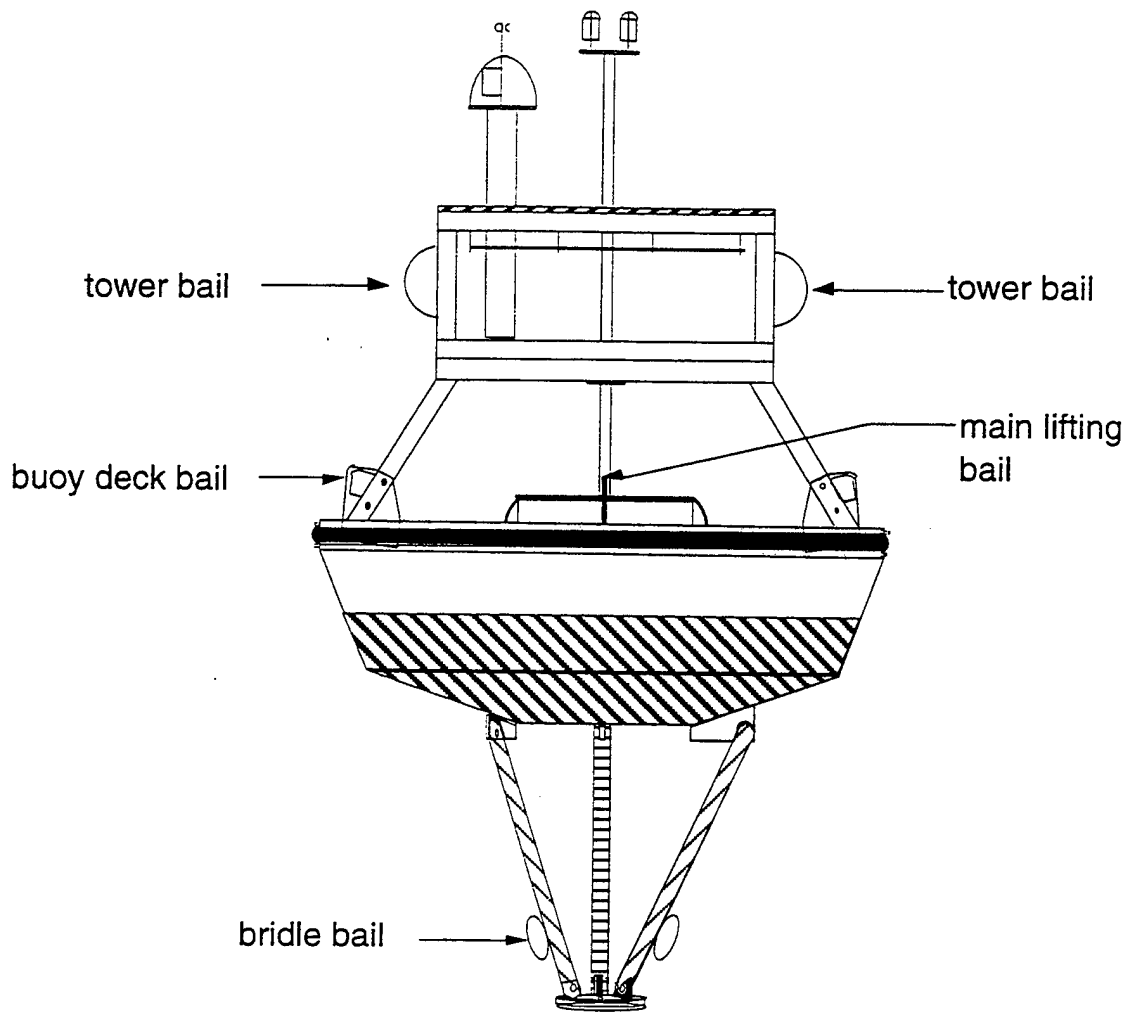

Figure A8-3: Disc buoy bail configuration.

rigged to check the tower swing as the hull swung outboard. A 75-foot buoy deck bail slip line was the most important of all the slip lines. This line prevented the buoy from spinning as the buoy settled out in the water. This was important so that the quick release hook, hanging from the crane's whip, could be released without fouling. The buoy deck bail slip line was removed just following the release of the discus into the sea. One additional line, called the whip tag line, was used in this operation. The whip tag line kept the whip away from the tower's meteorological sensors once the quick release hook had been pulled free and the discus was cast adrift.

The personnel utilized for this phase of the operation included a deck supervisor, two Lebus winch operators, two hauling wire handlers, three slip line handlers, a crane operator on the 01-deck, a HIAB crane operator, a crane whip tag line handler, and quick-release hook operator.

With all three slip lines in place the crane was directed to swing over the discus buoy. The extension of the crane's boom was approximately 60 feet. The crane's whip was lowered to the discus and the quick release hook was attached to the main lifting bail. Slight tension was taken up on the whip to take hold of the buoy. The chain lashings that were binding the discus to the deck were removed. The stopper line holding the suspended 40 meters of mooring string was eased off to allow the discus to take on that hanging tension. The discus was then raised up and swung outboard as the slip lines kept the hull in check. The bridle slip line was removed first followed by the tower bail slip line. Once the discus had settled into the water, approximately 20 feet from the side of the ship, and the release hook had gone slack, the quick release hook operator pulled the trip line and with the help of the tag line handler, cleared the whip away from the buoy forward. The slip line to the buoy deck bail should be cleared at approximately the same time the quick release hook is tripped or slightly before. If the discus were released prior to the buoy settling out in the water the tower could swing into the whip and cause potential damage to the tower sensors. The ship then maneuvered slowly ahead to allow the discus to pass around the stern of the ship. The HIAB crane holding the Yale grip on the hauling wire was cast off once the buoy had drifted aft to a position just forward of its extended boom.

The Lebus capstan operator was instructed to slowly haul in the hauling wire once the discus had straightened out behind the ship. The ship's speed was at that time increased to 1 knot through the water in order to maintain safe distance between the discus and the ship. Once this had occurred the bottom end of the 5.3-meter shot of 7/16" wire rope shackled to the hauling wire was hauled in and stopped off at the transom. The next instrument was brought out and shackled to the bitter end of the stopped off wire rope. At this point the remainder of the mooring was deployed using the WHOI Buoy Group's winch-to-deck stopper technique (Heinmiller, 1976).

Miscellaneous Notes

During all the deployments a digital tachometer, Ametek model #1726, was used in the calculation of mooring pay-out speed verses the ship's speed through the water. This tool was used as a check to see that the mooring was always being slightly towed during deployment. The tachometer utilized a rotating wheel which was manually placed against the wire or nylon rope being paid out over the stern. The selected readout from the tachometer was in miles per hour. Table A8-1 shows the corresponding tachometer reading for a given ship's speed.

Figures A8-4 to A8-9 illustrate how the deck layout changed as each mooring was recovered and then redeployed.

Table A8-1: Winch payout meter readings for different ship speeds.

Ship's Speed (knots)	Payout Meter Reading* (miles/hr)
0.25	0.24
0.5	0.49
0.75	0.73
1	0.97
1.25	1.21
1.5	1.46
1.75	1.7
2	1.94
2.25	2.19
2.5	2.43
2.75	2.68
3	2.92

* 10% less than ship's speed

Takes into consideration:

Nautical mile vs statute mile

10% reduction to prevent paying out faster than ship's speed

Winch drum I. D. vs drum O. D.

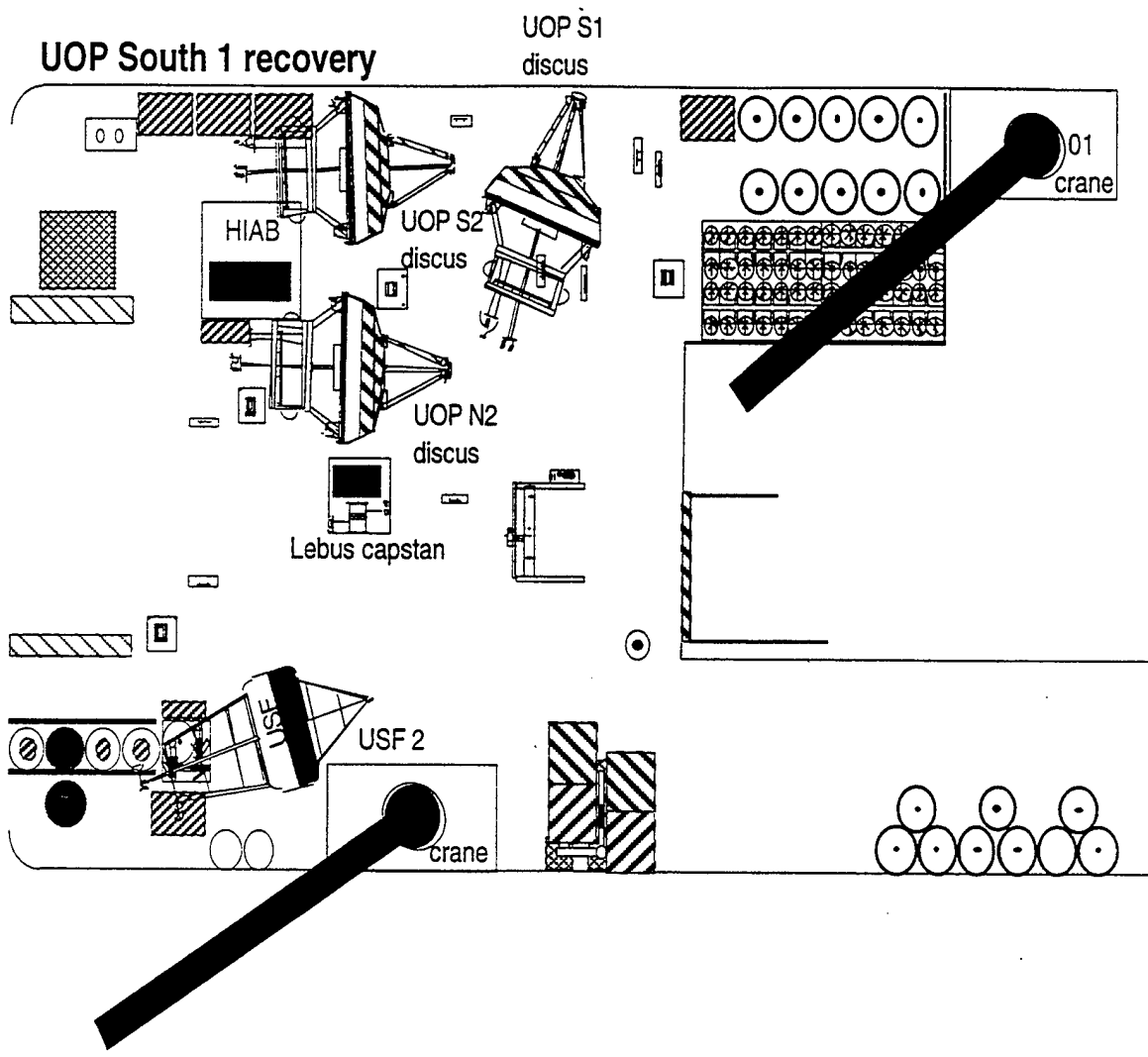

Figure A8-4: Deck layout following PACS 1 South recovery.

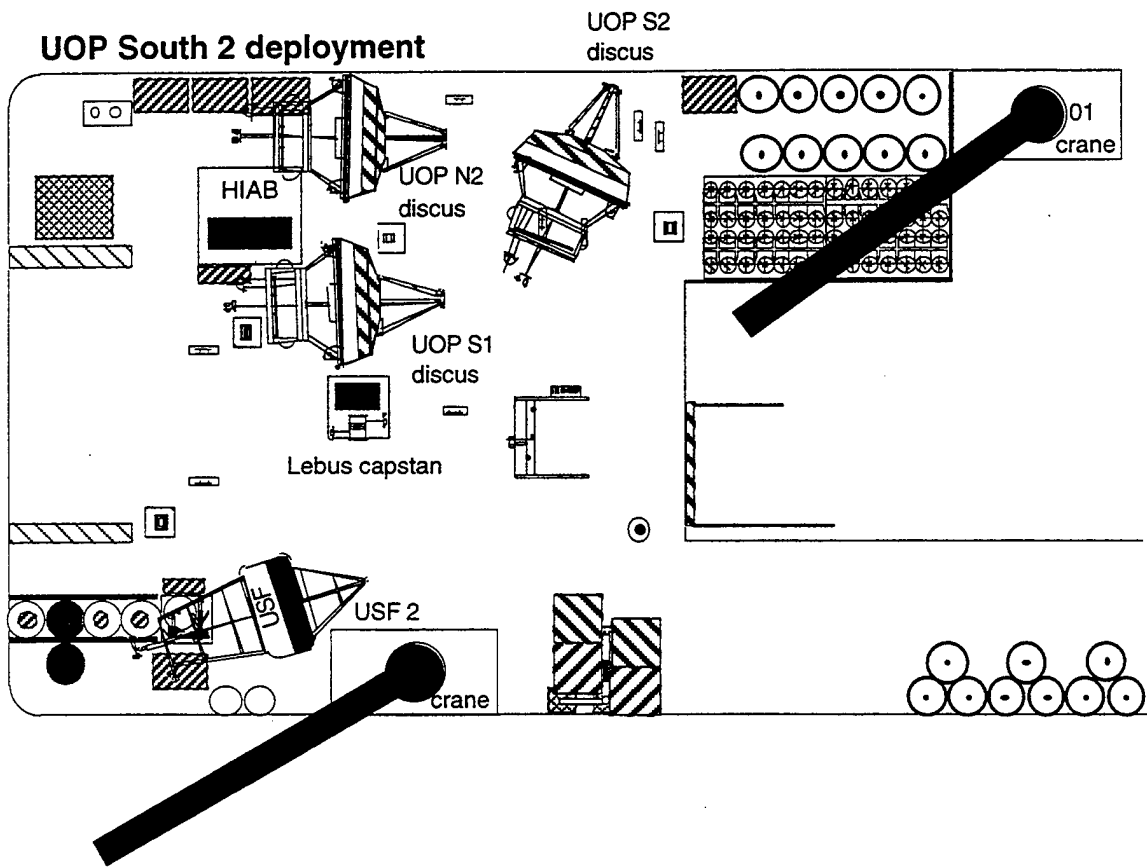

Figure A8-5: Deck layout prior to PACS 2 South deployment.

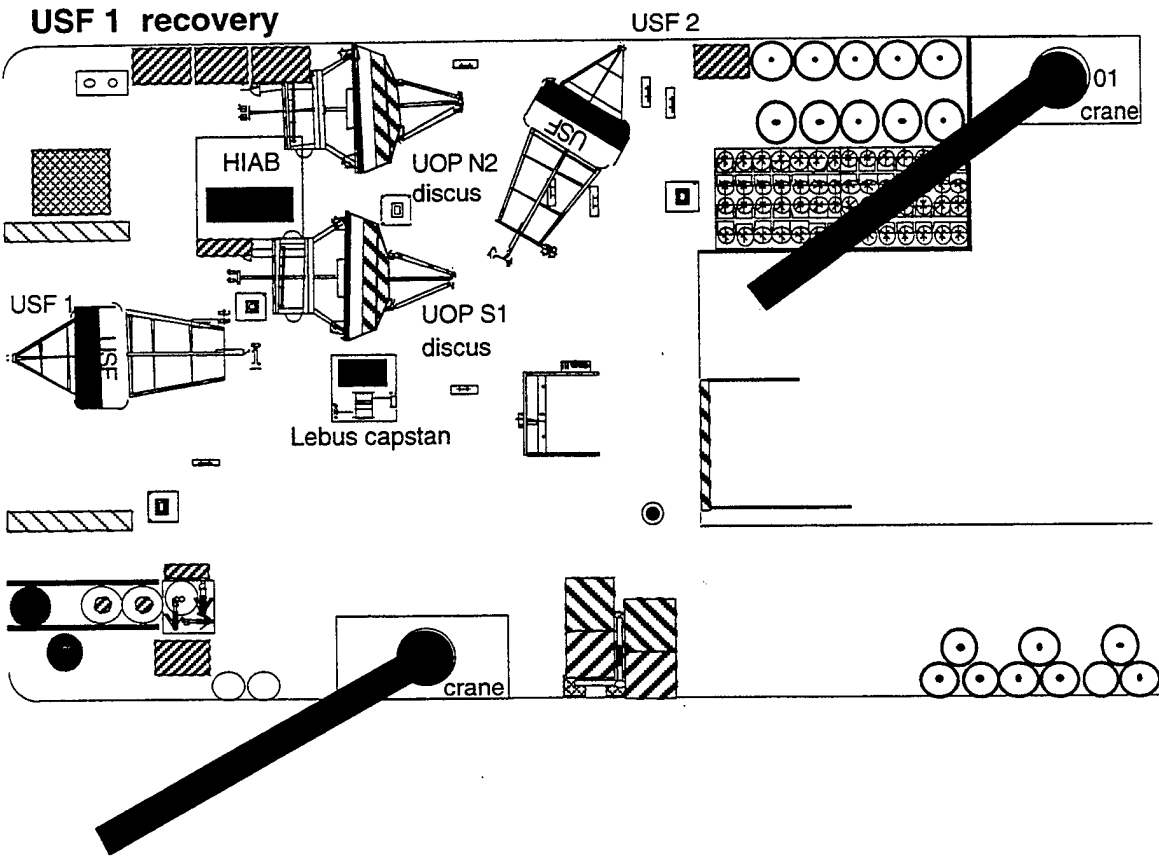

Figure A8-6: Deck layout following PACS 1 USF mooring recovery.

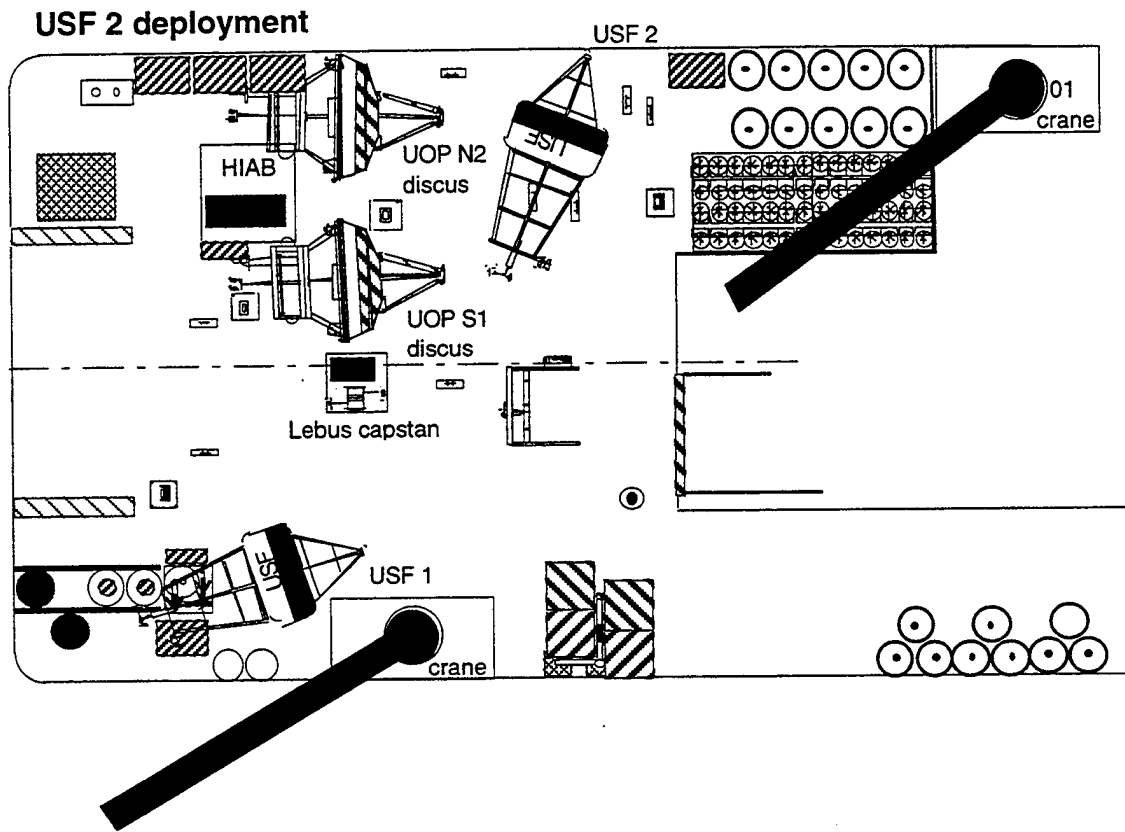

Figure A8-7: Deck layout prior to PACS 2 USF mooring deployment.

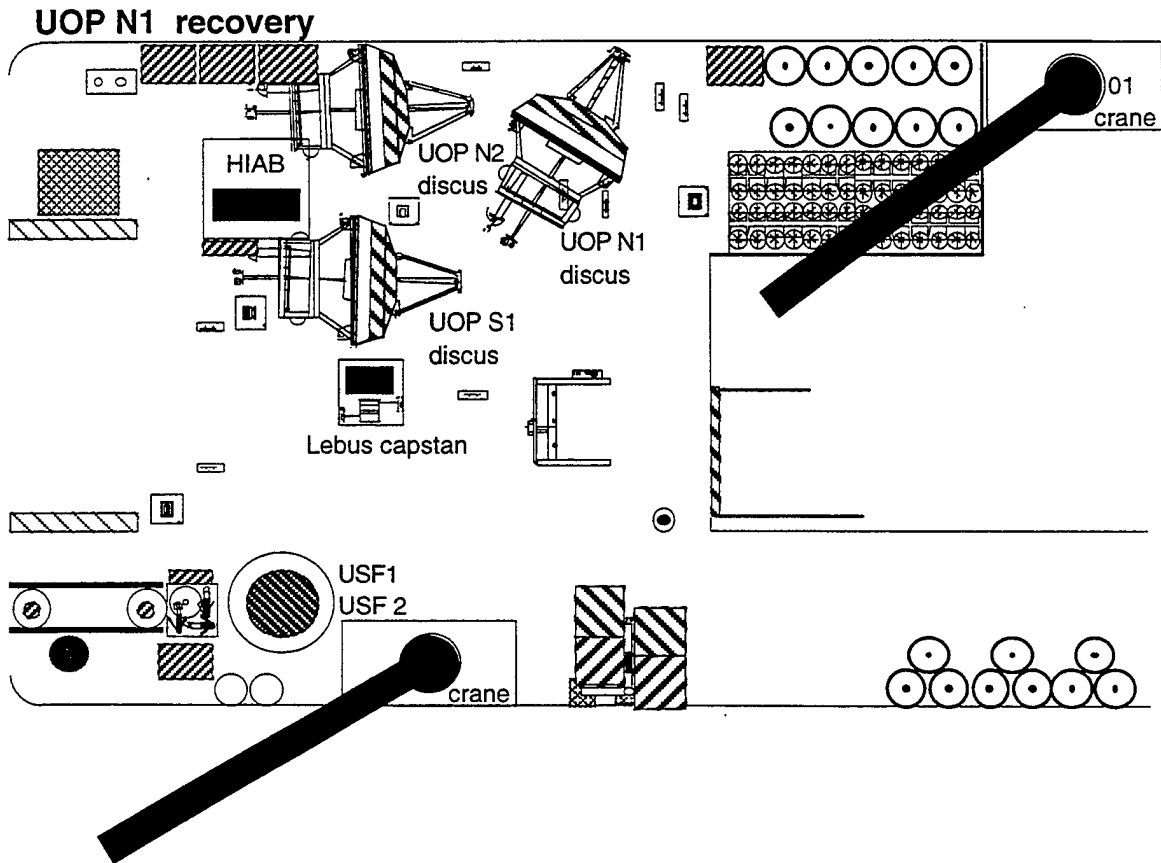

Figure A8-8: Deck layout following PACS 1 North recovery.

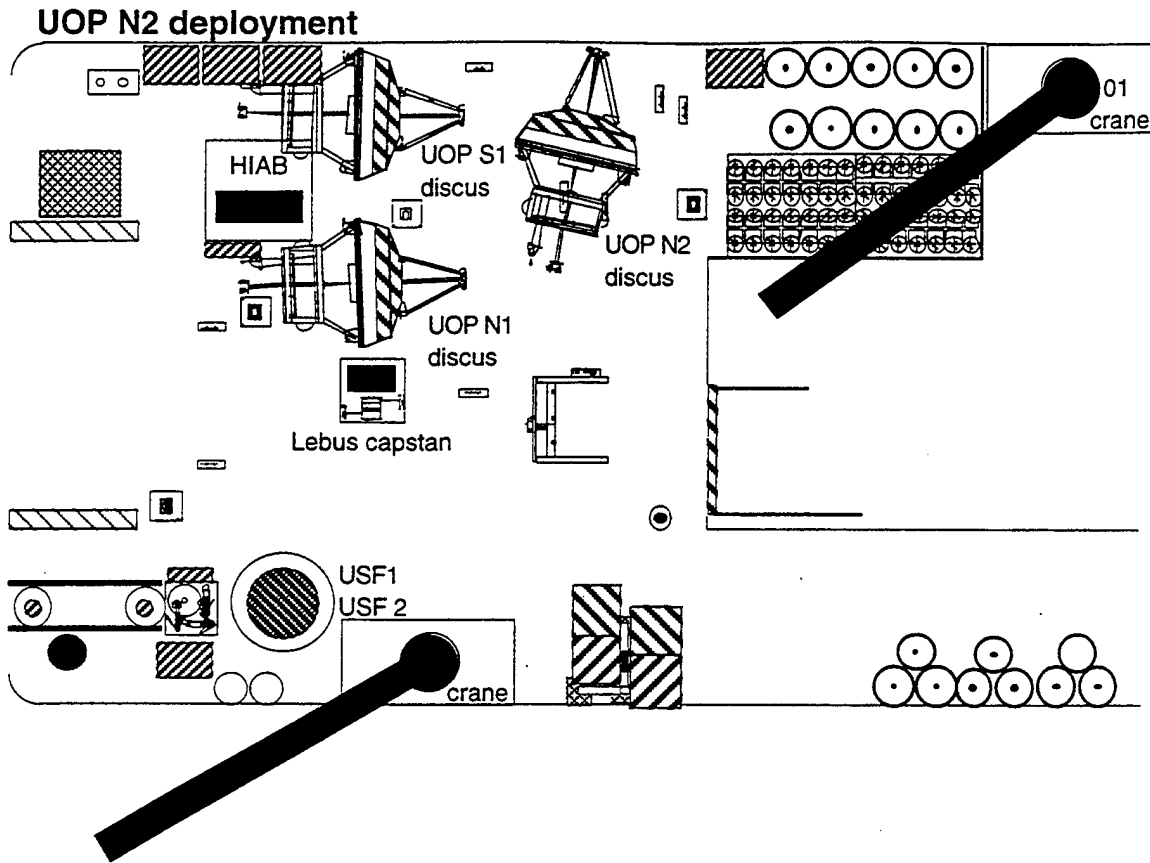

Figure A8-9: Deck layout prior to PACS 2 North deployment.

Appendix 9

PACS Antifouling Coating Test

For the past seven years the UOP Group has used Ameron 635 tributyltin-based antifouling paint on aluminum buoy hulls and sub-surface instrumentation to prevent fouling for up to eight months. Recently this antifouling coating has been out of production, and an alternate coating is being sought.

The PACS North and South discus hull bottoms were used as test surfaces for an intercomparison test between three antifouling paints. The coatings tested were: Pettit Alumacoat II, Ameron 635, and No Foul SN-1. The biocide used in the Pettit and Ameron paints is tributyltin. Both the Pettit and Ameron paints are federally regulated in their application and use. No Foul SN-1 is a vinyl copolymer antifouling paint that is free of copper and tributyltin. This paint has been reported to have good antifouling capabilities without the hazardous handling problems characteristic in the two other coatings. The purpose of this field test was to find an alternative to tributyltin-based antifouling paint which is environmentally safer in its application and use.

The buoy hulls were painted so that coatings would be subjected to similar current flow and swell impact around the hull. Figure A9-1 details the paint scheme used. Three coats of each paint type were applied by brush and hand roller. The dry mil thickness of the paints was approximately 6 mils. The tie coat on which the antifouling coatings were painted was Ameron PSX 700--a high-build siloxane coating.

The floating sea-surface temperature frame and float were painted with Ameron 635. The Brancker temperature pod pipe and the solar shield plates for the six near-surface temperature recorders were painted with No Foul SN-1. Following attachment of the solar-shielded temperature recorders onto the temperature pod pipe, the instruments and solar shields were spray painted with a tributyltin-based antifouling paint Interlux Yacht Classic 2837. This was done for additional protection against fouling. The discus bridle legs and attached sensor brackets were coated with No Foul SN-1. The VMCM instrument cage rods, instrument stings and fans were spray painted with two coats of Pettit Alumacoat II. All the thermister end caps of the Brancker temperature recorders were hand painted with Ameron 635. The Brancker wire clamp brackets were painted with No Foul SN-1.

Upon recovering the two PACS 1 discus moorings, it was very obvious that the ocean environment for both was conducive for prolific gooseneck barnacle fouling. The control stripe which separated the Alumacoat II, Ameron 635 and No Foul SN-1 on both discus hulls had colonies of *Lepas* gooseneck barnacles, which had grown to lengths in excess of 5 inches, and covered most of the unprotected control areas. The halo effect of the Alumacoat II and Ameron 635 was evident by the fewer numbers of barnacles that had grown within a 2-inch wide band adjacent to the control stripe. On the opposite side of the control stripe, barnacle growth was massed right to the edge where the No Foul SN-1 paint edge met the unprotected control. A thin coating of brown algae covered the entire bottom of both discus hulls. A high-pressure, salt-water washer was utilized to clean off the hulls. The South discus was recovered with a green grass algae several inches long growing over 75% of the deck. It has been speculated that this unusual fouling propagated from a combination of sea water constantly washing across the deck of the discus and bird guano.

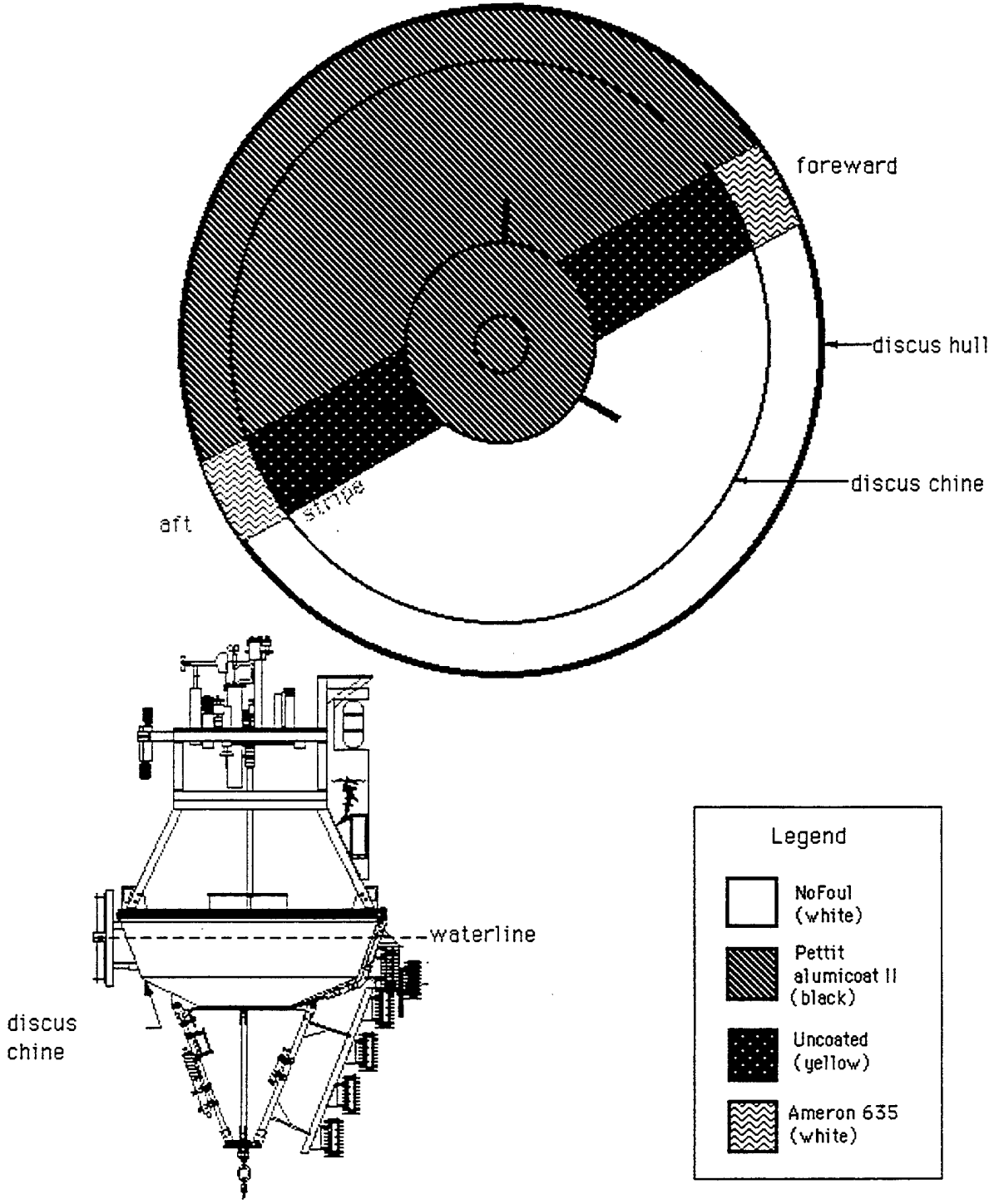

Figure A9-1: Antifouling paint test locations, PACS 1 North and South discus buoy hulls.

The solar-shielded Brancker temperature recorders were well protected with the combination of No Foul SN-1 and Interlux Yacht Classic 2837, with the exception of the nylon spacers that separated the 13 plates of each assembly. The VMCM propellers, instrument stings and cages had barnacles growing on areas where the coating had either ablated away or where there was insufficient paint coverage. Potential instrument fouling for the two moorings was approximately 100-meter deep to the surface.

The No Foul SN-1 performed as well as the tributyltin-base paints in this test. The No Foul SN-1 and Alumacoat II had lost most of their adhesive quality, which was evident during the cleaning of the hull bottoms following recovery. If the moorings had been left for an additional month or two, these paints would probably have failed. If all the coatings had had an additional 3 to 4 mils. of coating thickness, one could speculate that they could perform well for up to a year. Table A9-1 details the combined visual observation taken for the two discus hulls.

Table A9-1: Antifouling coating performance, PACS 1, North and South

Exposure: 9 months (April to December 1997); Nominal application thickness of 8 mils (2 coats).

<u>Sample</u>	<u>Color</u>	<u>Ablation*</u>	<u>Adhesion**</u>	<u>Fouling†</u>	<u>Algae film</u>
No Foul SN-1	White	80%	poor	>10%	100%
Pettit Alumacoat	Black	80%	good	>10%	100%
Ameron 635	White	50%	good	>10%	50%
Control	Yellow	na	na	100%	100%

* Ablation was estimated based on visual observation at time of recovery
 **Adhesion of the remaining coating was evaluated during high pressure washing.
 † Primarily Lepas gooseneck barnacles with nominal lengths of 5"

PACS II antifouling paint test

For the second deployment the PACS 2 North and South discus hulls were used as platforms to evaluate five antifouling paints suitable for moored aluminum buoy hulls. The paints tested were: Micron-33, Interlux Co.; No Foul SN-1, E Paint Co.; Bondit B-2, Reltek Co.; and two samples from Advanced Polymer Sciences (APS), Inc.--APS-BIO and APS-CAP.

Micron-33 is a tribytal, tin-based ablative. The No Foul SN-1 is a vinyl copolymer ablative that reacts with ultraviolet sunlight to produce hydrogen peroxide as a by-product. The hydrogen peroxide, in conjunction with an added organic algacide, acts as the bio-fouling deterrent. Bondit B-2 is a nontoxic, aethylene polymer that is reported to have good bonding and antifouling characteristics, as well as a longer service life compared to other bottom paints. The APS-BIO is an anti-bacterial ablative; and the APS-CAP is a hot-pepper, low-copper ablative. Table A9-2 details the wet film thickness, color and date of application of the samples.

Table A9- 2: Antifouling coatings tested, PACS 2 North

Test Platform: PACS 2 North and South Discus Buoys

Substrate: Aluminum Hull with top coat of instant set polyurethane elastomer.

Type of Exposure: Waterline to 1 meter depth.

Exposure: 9 months (December 97 to September 98)

<u>Sample</u>	<u>Color</u>	<u>Wet mil. Thickness and Application Date</u>
No Foul SN-1	White	8 mils. 10/97 plus 4 mils 12/97
Micron-33	Black	8 mils 10/97 plus 4 mils 12/97
Bondit B-2	Clear	3 mils 10/97
APS-CAP	Gray	10 mils 12/97
APS-BIO	Gray	10 mils 12/97

Figures A9-2 and A9-3 illustrate the painting schemes used for each discus hull. The No Foul SN-1 and Micron-33 test areas were painted on the discus hulls so that they would be evenly subjected to the current flow around the discus hull while the buoy was moored. The Bondit B-2 and APS coatings were applied to several test areas positioned around the discus hull chine. The control areas for this test were two, 3-inch wide stripes which separated the No Foul SN-1 and Micron-33. Half of the 12-inch x 12-inch test areas for the Bondit B-2 and APS-BIO and APS-CAP were left unprotected to act as the control. A high-solids epoxy--Ameron PSX 700--was the paint used for the control surfaces.

Upon recovery of the discus hulls in September 1998 the test paints will be visually inspected for adhesion and ablation of the remaining paint on the hull bottom and amount and type of biofouling.

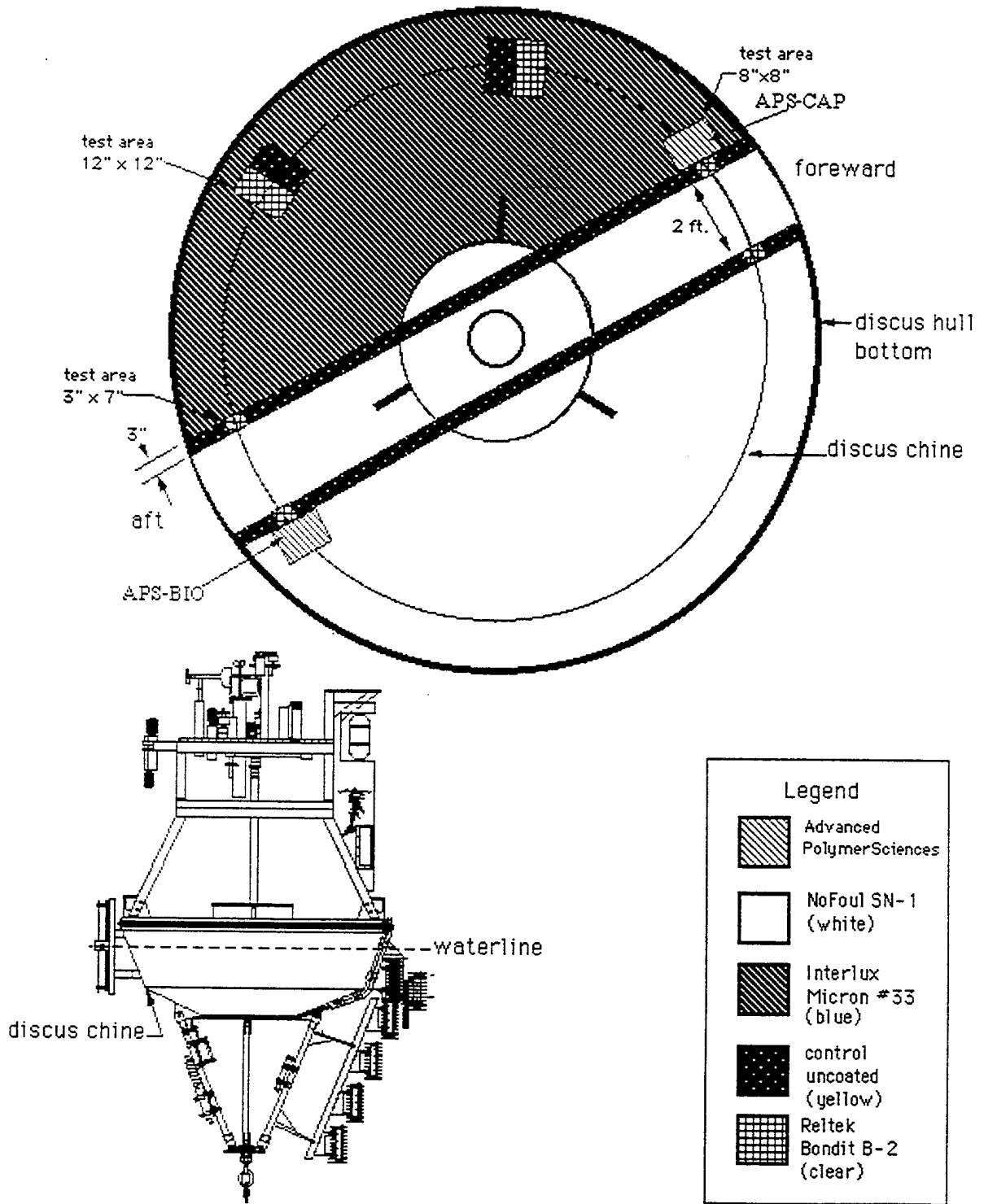

Figure A9-2: Antifouling paint test locations, PACS 2 North buoy hull.

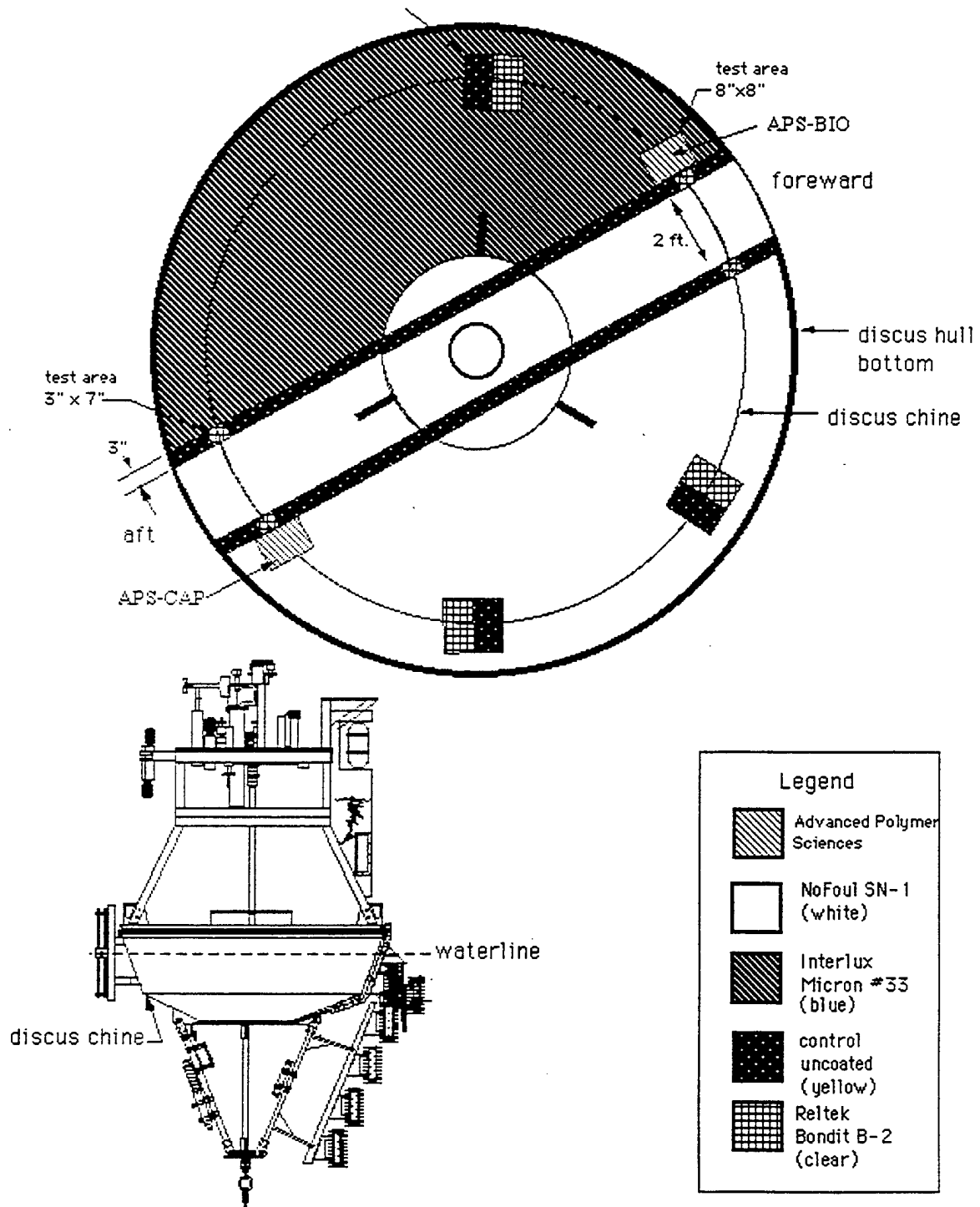

Figure A9-3: Antifouling paint test locations, PACS 2 South buoy hull.

DOCUMENT LIBRARY

Distribution List for Technical Report Exchange - July 1998

University of California, San Diego
SIO Library 0175C
9500 Gilman Drive
La Jolla, CA 92093-0175

Hancock Library of Biology & Oceanography
Alan Hancock Laboratory
University of Southern California
University Park
Los Angeles, CA 90089-0371

Gifts & Exchanges
Library
Bedford Institute of Oceanography
P.O. Box 1006
Dartmouth, NS, B2Y 4A2, CANADA

NOAA/EDIS Miami Library Center
4301 Rickenbacker Causeway
Miami, FL 33149

Research Library
U.S. Army Corps of Engineers
Waterways Experiment Station
3909 Halls Ferry Road
Vicksburg, MS 39180-6199

Marine Resources Information Center
Building E38-320
MIT
Cambridge, MA 02139

Library
Lamont-Doherty Geological Observatory
Columbia University
Palisades, NY 10964

Library
Serials Department
Oregon State University
Corvallis, OR 97331

Pell Marine Science Library
University of Rhode Island
Narragansett Bay Campus
Narragansett, RI 02882

Working Collection
Texas A&M University
Dept. of Oceanography
College Station, TX 77843

Fisheries-Oceanography Library
151 Oceanography Teaching Bldg.
University of Washington
Seattle, WA 98195

Library
R.S.M.A.S.
University of Miami
4600 Rickenbacker Causeway
Miami, FL 33149

Maury Oceanographic Library
Naval Oceanographic Office
Building 1003 South
1002 Balch Blvd.
Stennis Space Center, MS, 39522-5001

Library
Institute of Ocean Sciences
P.O. Box 6000
Sidney, B.C. V8L 4B2
CANADA

National Oceanographic Library
Southampton Oceanography Centre
European Way
Southampton SO14 3ZH
UK

The Librarian
CSIRO Marine Laboratories
G.P.O. Box 1538
Hobart, Tasmania
AUSTRALIA 7001

Library
Proudman Oceanographic Laboratory
Bidston Observatory
Birkenhead
Merseyside L43 7 RA
UNITED KINGDOM

IFREMER
Centre de Brest
Service Documentation - Publications
BP 70 29280 PLOUZANE
FRANCE

REPORT DOCUMENTATION PAGE	1. REPORT NO. WHOI-98-18	2. UOP 98-02	3. Recipient's Accession No.
4. Title and Subtitle Pan American Climate Study (PACS), Mooring Recovery and Deployment Cruise Report, R/V <i>Thomas Thompson</i> Cruise Number 73, 28 November to 26 December 1997		5. Report Date August 1998	
7. Author(s) Richard P. Trask, Robert A. Weller, William M. Ostrom, Bryan S. Way		8. Performing Organization Rept. No. WHOI-98-18	
9. Performing Organization Name and Address Woods Hole Oceanographic Institution Woods Hole, Massachusetts 02543		10. Project/Task/Work Unit No.	
		11. Contract(C) or Grant(G) No. (C) NA66GP0130 (G)	
12. Sponsoring Organization Name and Address National Oceanic and Atmospheric Administration		13. Type of Report & Period Covered Technical Report	
		14.	
15. Supplementary Notes This report should be cited as: Woods Hole Oceanog. Inst. Tech. Rept., WHOI-98-18.			
16. Abstract (Limit: 200 words) Three surface moorings were recovered and redeployed during R/V <i>Thomas Thompson</i> cruise number 73 in the eastern equatorial Pacific as part of the Pan American Climate Study (PACS). PACS is a NOAA-funded study with the goal of investigating links between sea-surface temperature variability in the tropical oceans near the Americas and climate over the American continents. The three moorings were deployed near 125°W, spanning the strong meridional sea-surface temperature gradient associated with the cold tongue south of the equator and the warmer ocean north of the equator, near the northernmost, summer location of the Intertropical Convergence Zone. The moored array was deployed to improve the understanding of air-sea fluxes and of the processes that control the evolution of the sea surface temperature field in the region. Two surface moorings, located at 3°S, 125°W and 10°N, 125°W, belonging to the Upper Ocean Processes (UOP) Group at the Woods Hole Oceanographic Institution (WHOI), were recovered after being on station for eight months and redeployed. Two eight-month deployments were planned. A third mooring deployed at the equator and 128°W by the Ocean Circulation Group at the University of South Florida (USF) was also recovered and redeployed. The USF mooring, unfortunately, had to be recovered immediately following redeployment due to a problem with the buoy and instrumentation. The buoys of the two WHOI moorings were each equipped with meteorological instrumentation, including a Vector Averaging Wind Recorder (VAWR), and an Improved Meteorological (IMET) system. The WHOI moorings also carried Vector Measuring Current Meters, single point temperature recorders, and conductivity and temperature recorders located in the upper 200 meters of the mooring line. In addition to the instrumentation noted above, a variety of other instruments, including an acoustic current meter, acoustic doppler current meters, bio-optical instrument packages and an acoustic rain gauge, were deployed during the PACS field program. The USF mooring had an IMET system on the surface buoy and for oceanographic instrumentation, two RD Instruments acoustic doppler current profilers (ADCPs), single-point temperature recorders, and conductivity and temperature recorders. Conductivity-temperature-depth (CTD) profiles were made at each mooring site and during the transit between mooring locations. This report describes, in a general manner, the work that took place during R/V <i>Thomas Thompson</i> cruise number 73. A description of the WHOI moored array and instrumentation is provided. Details of the mooring designs and preliminary data from the CTD profiles are included.			
17. Document Analysis a. Descriptors air-sea interaction moored instrument measurements PACS: eastern tropical Pacific b. Identifiers/Open-Ended Terms c. COSATI Field/Group			
18. Availability Statement Approved for public release; distribution unlimited.		19. Security Class (This Report) UNCLASSIFIED	21. No. of Pages 107
		20. Security Class (This Page)	22. Price