

THE QUALITY IMPROVED 1

# Structural Analysis of DEW Line Station DYE-2, Greenland

1983-1988

Michael R. Walsh and Herbert T. Ueda

June 1998

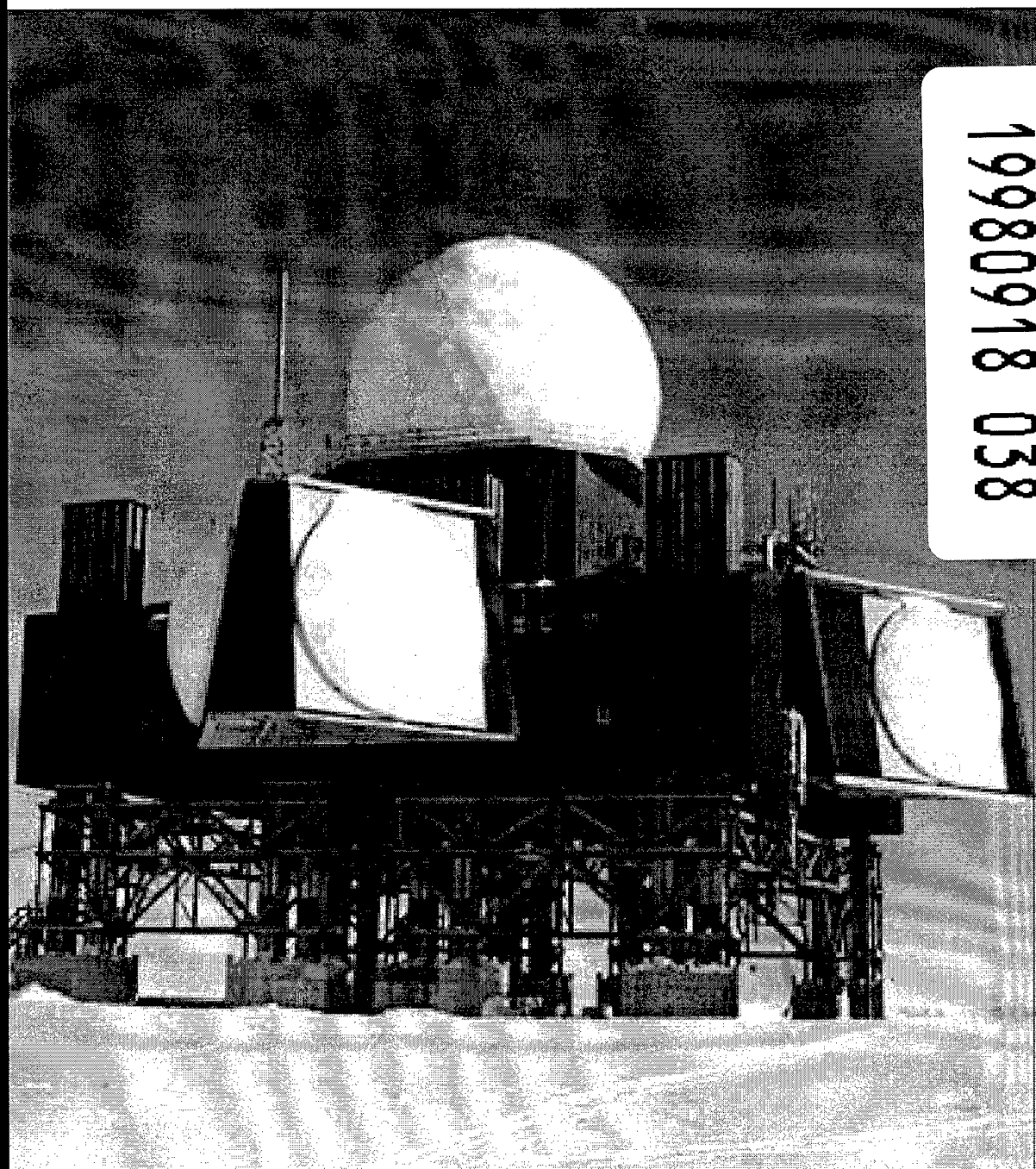

19980918 038

AG. I 98-12-24 76

**Abstract:** DYE-2, a Distant Early Warning station, is located on the Greenland ice cap approximately along the Arctic Circle, 470 km from the west coast. The viscous nature of the material on which the structure is grounded made periodic monitoring and maintenance of the supporting structure necessary. This report analyzes the stresses developed within the structure from the last major maintenance operation, a 64-m sideways move in 1982 to a new foundation, to the final set of stress measurements taken at the abandoned

site in 1988. Conclusions drawn from these measurements and the subsequent analysis were that the building system was continuing to tilt in one direction because of differential footing settlement caused by changing footing conditions, and high structural stresses would make it unsafe for reoccupation after December of 1988 unless emergency maintenance was performed. The U.S. Air Force officially abandoned the site in August 1988 as a result of this analysis.

*Cover: Distant Early Warning Station DYE-3 on the Greenland ice cap, 1986. Supporting structure can be seen beneath the building. (DYE-3 has the same structural design as DYE-2.)*

**How to get copies of CRREL technical publications:**

Department of Defense personnel and contractors may order reports through the Defense Technical Information Center:

DTIC-BR SUITE 0944  
8725 JOHN J KINGMAN RD  
FT BELVOIR VA 22060-6218  
Telephone 1 800 225 3842  
E-mail help@dtic.mil  
msorders@dtic.mil  
WWW http://www.dtic.mil/

All others may order reports through the National Technical Information Service:

NTIS  
5285 PORT ROYAL RD  
SPRINGFIELD VA 22161  
Telephone 1 703 487 4650  
1 703 487 4639 (TDD for the hearing-impaired)  
E-mail orders@ntis.fedworld.gov  
WWW http://www.fedworld.gov/ntis/ntishome.html

A complete list of all CRREL technical publications is available from

USACRREL (CECRL-IB)  
72 LYME RD  
HANOVER NH 03755-1290  
Telephone 1 603 646 4338  
E-mail techpubs@crrel.usace.army.mil

**For information on all aspects of the Cold Regions Research and Engineering Laboratory, visit our World Wide Web site:**  
<http://www.crrel.usace.army.mil>

CRREL Report 98-3



**US Army Corps  
of Engineers®**

Cold Regions Research &  
Engineering Laboratory

# **Structural Analysis of DEW Line Station DYE-2, Greenland 1983-1988**

Michael R. Walsh and Herbert T. Ueda

June 1998

Prepared for  
U.S. AIR FORCE

Approved for public release; distribution is unlimited.

## PREFACE

This report was prepared by Michael R. Walsh and Herbert T. Ueda (ret.), Mechanical Engineers, Engineering Resources Branch, Applied Science and Technology Directorate, U.S. Army Cold Regions Research and Engineering Laboratory (CRREL), Hanover, New Hampshire. Funding for this project was provided by the U.S. Air Force.

Technical reviewers for this report were Charles Korhonen and John R. Bouzoun of CRREL.

The authors thank Stewart Osgood of Metcalf & Eddy, Inc., for his assistance and contributions during the work on the measurement of stresses at DYE-2 and his valuable input in the evaluation of DYE-2 during the last trip to the site in August of 1988. Some of the photographs of the column footing Leuder lines were provided by Mr. Osgood. Wayne Tobiasson (ret.), CRREL, was the project principal investigator and provided much valuable information.

The contents of this report are not to be used for advertising or promotional purposes. Citation of brand names does not constitute an official endorsement or approval of the use of such commercial products.

## CONTENTS

Preface .....	ii
Summary .....	v
Introduction .....	1
Background .....	1
Structural system .....	3
Structural influences .....	4
Measurement considerations .....	6
Structural stresses .....	7
Footing settlements and tilts .....	9
Column tilts .....	13
Discussion .....	14
Closure of DYE-2 .....	16
Literature cited .....	17
DYE-2 literature .....	17
Appendix A: Movement of DYE sites on Greenland ice cap .....	19
Appendix B: Supporting structure stress measurement data, 1983–1988 .....	21
Appendix C: Field personnel, 1983–1988 .....	23

## ILLUSTRATIONS

Figure	
1. Location of Greenland ice cap DEW line stations .....	1
2. DYE-2: 1986 .....	2
3. DYE-2: 1977 .....	2
4. DYE-2 move: 1982 .....	2
5. DYE-2 trusses and collars: 1982 .....	3
6. Footing–column–truss system: plan view .....	3
7. Truss system collars .....	3
8. Truss collars .....	4
9. Column footings .....	4
10. Horizontal movement of columns at snow surface .....	5
11. Leuder lines: column A base .....	6
12. Summary of base level stress concentration factors: 1984–1988 .....	9
13. Footing settlements: 1982–1988 .....	11
14. Footing settlement trends .....	11
15. Flooding of footing N1, August 1988 .....	12
16. Footing tilts: 1982–1988 .....	13
17. Footing tilt trends .....	13
18. Column tilt trends .....	15
19. Example of load (pressure)–displacement measurement .....	15
20. Extrapolation of base level combined stress factors for column A4 .....	16

## TABLES

### Table

1. DYE-2 milestones .....	6
2. Column vertical loads .....	7
3. Footing settlements .....	10
4. Footing tilts and resultants .....	12
5. Column tilts .....	14

## SUMMARY

Since DYE-2 was moved sideways 64 m in 1982, settlement problems and associated accumulating stresses in the supporting structure have plagued the site. Data gathered between the years 1982 and 1988 show an inexorable trend involving differential footing settlements and tilts, with related structural stresses and stress patterns. Column tilt data, although incomplete, serve to reinforce these data. Analysis of these data indicate that the structure as a whole is tilting unidirectionally towards the "warm" corner of the building (column N1). The presence of a large volume of water at the base of column N1 further indicates that the cause of the settlement problem may be a disturbance of the snow beneath the column footings because of meltwater or heat transfer between the meltwater and the underlying snow. Whatever the cause, projections of base level stress concentrations indicated an increase in stresses above tolerable levels before 1989.

An attempt was made in 1987 to structurally counteract these problems and, in a secondary manner, to relieve the high stresses being experienced by the columns and trusses of the supporting structure. Although partially successful, with the structural stresses lowered and redistributed as well as straightening the columns, it could not alleviate the underlying problem of differential settlement. On 24 August 1988, the Air Force, using the information and analysis provided them

by CRREL, decided to abandon DYE-2 by 1 October 1988. Safety concerns over rising stress levels were cited as the reason. Shortly thereafter, the site was reoccupied for a few days and then abandoned. It remains abandoned to this day. The closure of DYE-2 was followed shortly by the closure of DYE-3 and DYE-4, located on Greenland's east coast. DYE-1 maintained limited operations for a period of time but is closed today, ending 30 years of continuous service in defense of this nation.

The continued relevance of the work at the Greenland ice cap stations can be seen in the design of the new South Pole Station in Antarctica. Like the DYE sites, the new South Pole Station will be a large steel structure mounted on multiple columns above the snow surface. The problems that crippled DYE-2 must be considered in the design and maintenance of the new South Pole Station, namely, stability of the column footings and contamination of those footings with meltwater. Although solar-generated meltwater should not be as great a problem as in Greenland because of the much lower maximum temperatures, the new building's conducted heat, liquid water from ruptured utilities, and meltwater from warm building surfaces must be carefully monitored. All three of these problems contributed to the demise of DYE-2. The consequences of footing failure at the new South Pole Station would be much more severe than those at the obsolete DYE sites.

# Structural Analysis of DEW Line Station DYE-2, Greenland 1983-1988

MICHAEL R. WALSH AND HERBERT T. UEDA

## INTRODUCTION

The U. S. Air Force Distant Early Warning Line (USAF DEW line) consisted at the time of this work of a series of manned stations located across the North American Arctic. The mission of these stations included direct-line microwave communications extending from Alaska to Europe as well as aircraft surveillance, acting as our nation's first line of defense. In 1959-60, four DEW line stations were built across Greenland. These stations, code named DYE (from Cape Dyer, Baffin Island, Canada, location of DYE-Main), were located approximately along the Arctic Circle. Two of these stations, DYE-2 and DYE-3, were positioned upon the ice cap (Fig. 1).

This report will present an analysis of the stresses imposed on the supporting structure of one of the two ice cap stations, DYE-2. The time span under consideration is from June of 1983 to August of 1988. This corresponds to the years between the final major maintenance operation at the station to its initial abandonment by U.S. Air Force contract personnel and subsequent closure. Technical factors contributing to the station abandonment will also be discussed.

## BACKGROUND

The ice cap DYE sites were large, 3270-tonne steel frame multipurpose buildings supported on two rows of four extensible columns. Each column, consisting of two axially symmetric column halves, was supported on a spread footing foundation many meters below the surface. Six columns rest on a 7.6- × 10.1-m footing while the remaining two rest on 7.6- × 9.1-m footings. The building dimensions are approximately 36.6 m

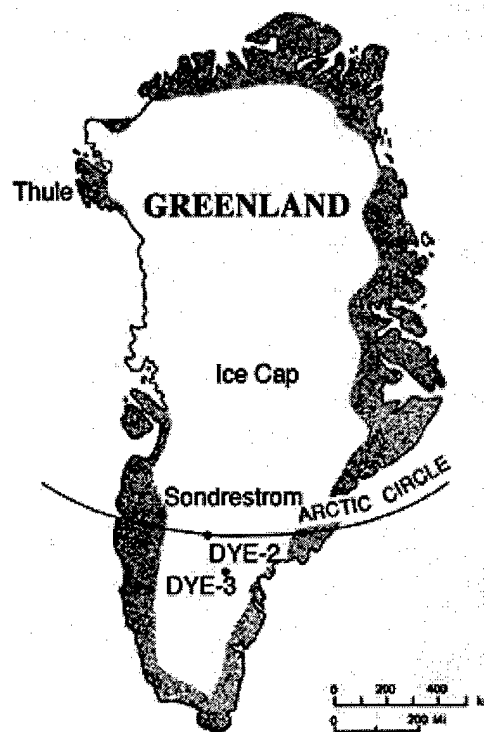

Figure 1. Location of Greenland ice cap DEW line stations.

square by 15.25 m high with an 24.4-m-diam. radome on the top (Fig. 2).

At DYE-2, snow accumulates at a rate of approximately 76 cm per year. Due to this accumulation, the building had to be raised periodically. Although originally designed for a useful life of only 10 years, several lifting operations extended its life into the early 1980s. These operations entailed adding on to the supporting columns and then lifting the building through a jack-screw mechanism between the building truss frame

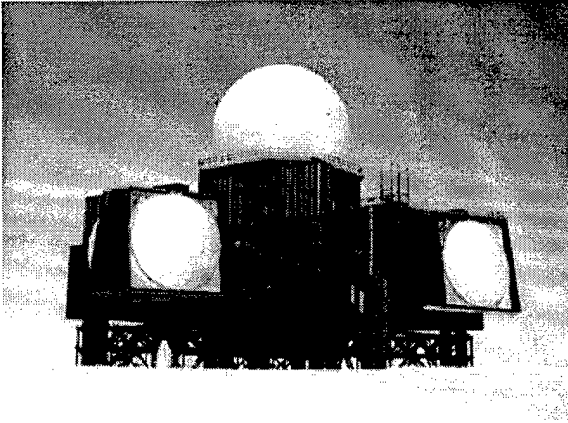

Figure 2. DYE-2: 1986.

and each of the eight columns, thus lifting the building along the columns. By 1980, the building had been lifted over 22.8 m above its original height. The supporting column height beneath the building was approximately 47 m, of which 43 m extended below the surface of the snow within protective enclosures to the original footings (Fig. 3).

During the intervening years, the column foundations had been distorted by differential settlement due to the nature of the supporting snow. The foundation distortions caused secondary stresses to accumulate in the structural frame. In addition, hydrostatic pressure from the surrounding snow became higher as the building was raised and the column length below the snow surface increased. Eventually, the pressure was high enough to begin distorting and crushing the protective wooden enclosures, shown beneath the building in Figure 3.

Realizing the importance of knowing the magnitude of these stresses for predicting build-

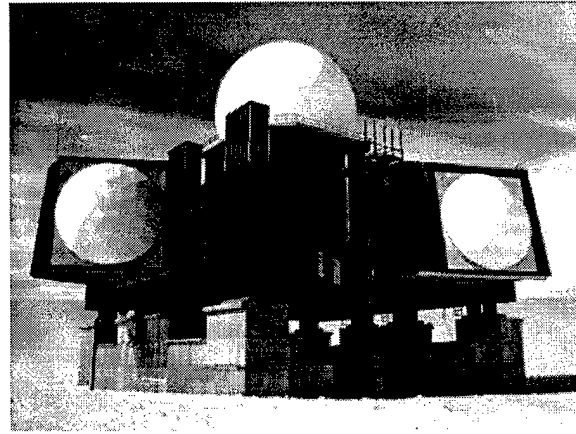

Figure 3. DYE-2: 1977.

ing behavior and the useful life of the site, CRREL personnel developed methods for determining these stresses by measuring loads at column restraint locations. Details of the techniques for measuring these forces are described in Ueda et al. (1984) and Tobiasson et al. (1974) and will be covered in brief later in this report. Over the years, measurements were taken to determine the amounts at which these loads were increasing (Ueda et al. 1984). Other factors which may have an effect on the site's structural support integrity, such as column tilts, surrounding snow levels, column footing settlements, and other site operational functions, were also monitored.

By the early 1980s, measurements indicated that column stresses were sufficiently high to require drastic remedial action. In 1982, the supporting structure was severed at a new base level, and DYE-2 was moved sideways 64 m onto a new set of footings (Fig. 4). The following year, the building was lifted 8.2 m. Since that time, CRREL personnel monitored building and col-

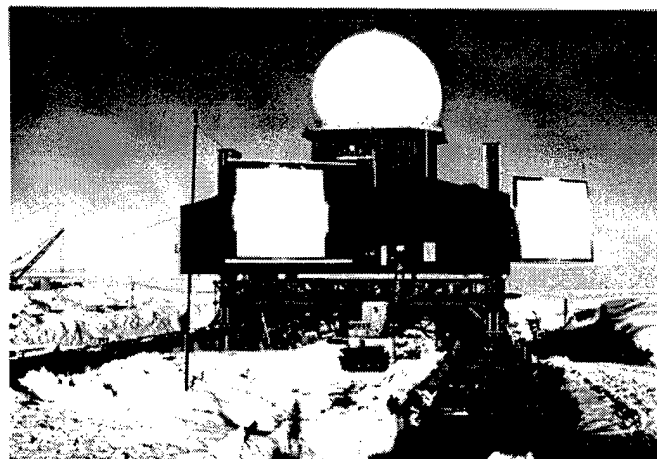
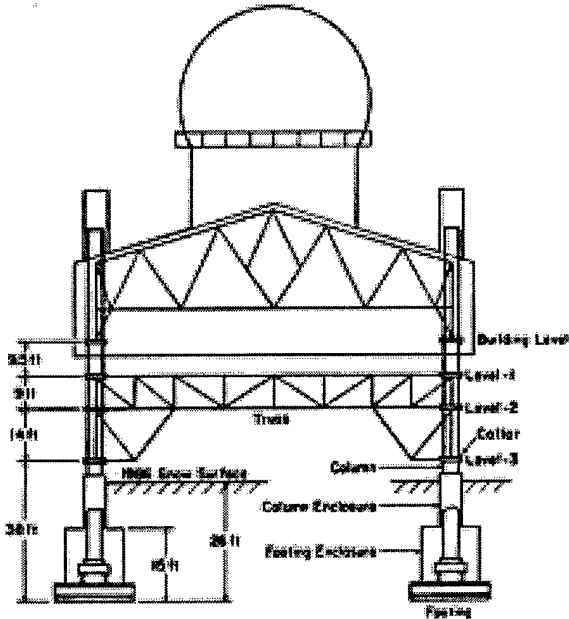

Figure 4. DYE-2 move: 1982.

umn stresses at truss-column interaction locations. The remainder of this report deals with the structural behavior of DYE-2 after the 1983 lift operation.

### STRUCTURAL SYSTEM

DYE-2 is a steel composite building supported by eight columns at the second floor level by a



a. Elevation cross section.

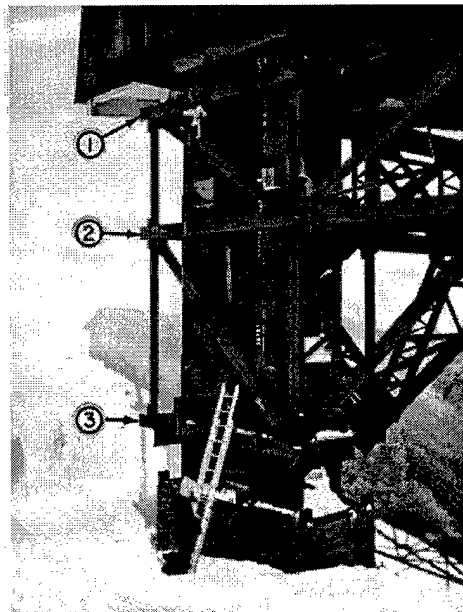

b. External collar location.

Figure 5. DYE-2 trusses and collars: 1986.

system of modified Warren trusses (Fig. 5). Below the building but above the snow surface are two truss systems that surround four columns each (Fig. 6). The trusses interact horizontally with each column through a series of three collars (Fig. 7). Within these collars and at the building collar located at the level, the columns and confining trusses interact through an array of sway bolts, which act like setscrews against different faces of the columns (Fig. 7 and 8). The truss system is vertically supported at the lower collar on steel channels welded to the columns. Friction-reducing Teflon-on-stainless-steel bearing pads are located between the supporting channels and the lower collars of the trusses. The complete support system finally rests on the snow through support blocks and large timber footings at the base of the columns (Fig. 9).

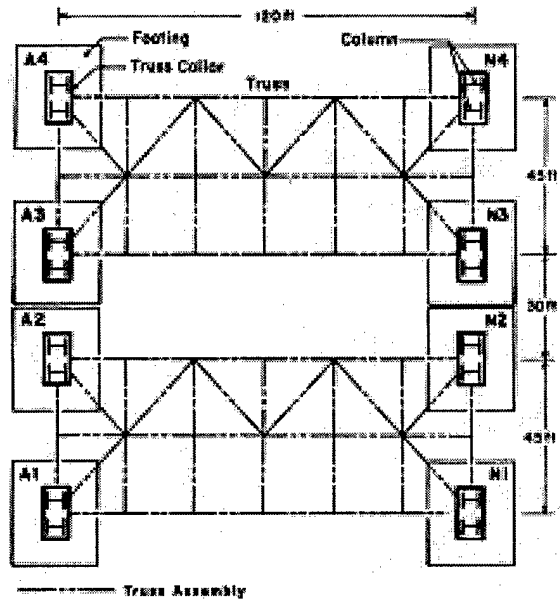

Figure 6. Footing-column-truss system: plan view.

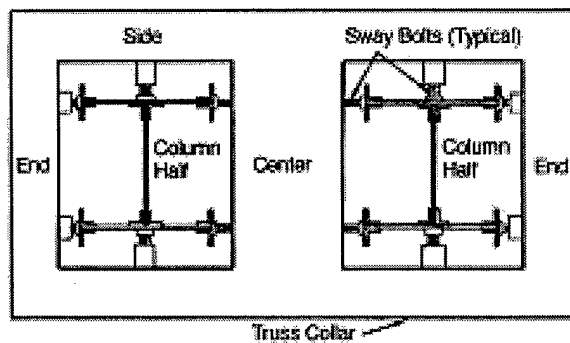

Figure 7. Truss system collars.

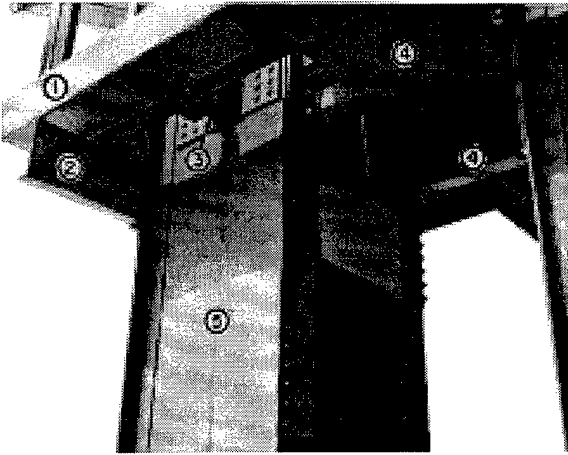

Figure 8. Truss collars.

1-collar, 2-support channel, 3-side-acting bolt, 4-end-acting sway bolt, and 5-column half.

The truss systems serve to stiffen the eight columns by bracing the columns horizontally. This was necessary because of the length of the columns and their associated weakness to large horizontal loads, such as wind loads. The collars surrounding the columns contain 12 adjustable sway bolts each. These sway bolts transmitted the forces through the columns to the collars and vice versa. The whole system acted to distribute loads throughout the four columns contained within each of the two truss systems. Static forces between the trusses and columns were measured at the sway bolt locations.

A similar arrangement exists at the building level. In this case, the collars were built into the

building frame at the first floor level. These collars and sway bolts serve to stiffen the columns at the lower building level.

## STRUCTURAL INFLUENCES

There were several factors that could affect the structure of the ice cap DYE sites. They can be grouped into two broad categories: dynamic and static. Dynamic factors, such as wind loading and vibrations (Haynes 1988), will not be discussed in this report. Our concern was strictly with the static performance of the building support system. Four of the more important static factors were (1) differential settlement of the footings beneath the columns, (2) tilting of these footings, (3) column plumbness or tilt, and (4) horizontal forces on the columns within the truss system. Technical considerations for each of these factors and how they could affect the stresses within the supporting columns will be discussed in this section.

Differential settlement of the column footings is caused by differences in densification rates of the foundation snow beneath each column footing. At DYE-2, the snow was not of uniform consistency because of the presence of ice lenses of various sizes and thicknesses imbedded in the matrix of the snow. These "defects" were formed by snow melting and refreezing during the warm summer months and subsequent burial beneath drifted or fallen snow. Matrix density irregularities cause differences in the densification rate for a given load, and thus settlement irregu-

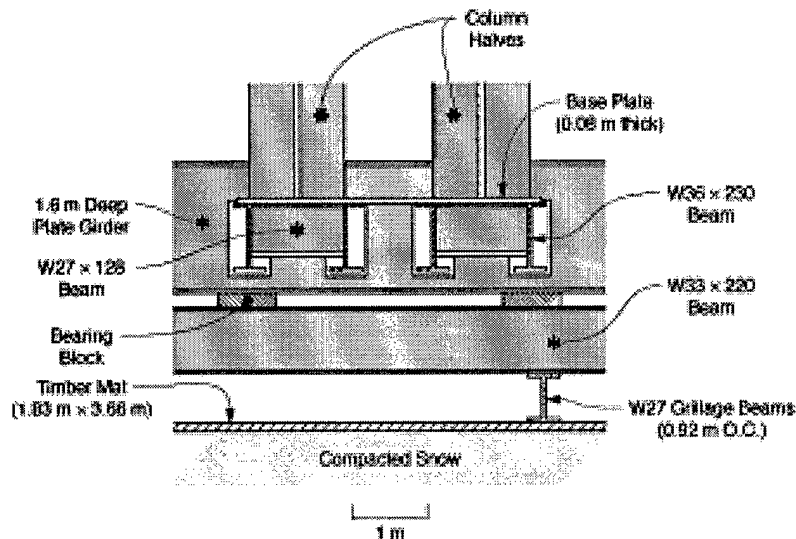

Figure 9. Column footings.

larities can occur beneath different columns. A column that settles more rapidly on its snow foundation will not support as much load as the adjoining columns, which then must assume a portion of the sunken column's load. Continued settlement will result in structural tilting and a redistribution of stresses. This results in increased stresses in the structure because of uneven loading and tilting.

The problems associated with differential settlement were partially compensated for throughout the station's life by performing structural maintenance operations called "mini-lifts," wherein the building is jacked (with the trusses attached) just enough to relevel the building and trusses. This redistributes the loads and thus enables the columns to assume a more equal load distribution, but does not address the underlying problem of differential footing settlements. Thus, although building distortion and truss stress problems at the site were addressed, differential settlement continued to plague DYE-2 after the 1982 move.

Two forms of tilting will occur during settlement: footing and column tilt. According to a computerized structural analysis done by Metcalf & Eddy Engineers, Inc. (1987), footing tilt can induce large stresses into the structural frame. Some of these stresses, caused by column out-of-plumbness and the resulting high moments, can exceed the critical value for yielding at the column bases. Modifications made in conjunction with the sideways move in 1982 permit some compensation for footing tilt through the use of shims, which can be inserted at the four bearing blocks at the base where each column bears on its footing (Fig. 9). Again, this was compensating for the effects of the problem, not addressing it, although the reduction in stress due to shimming did enhance the structural integrity of the system over a short period of time.

A more serious phenomenon associated with differential settlement is column tilt. Column tilts are caused by the structural system leaning in one direction, as opposed to plumbness difficulties caused by individual footing tilts. However, footing tilts can exacerbate column tilts and vice versa, so the system as a whole can act as an open-loop feedback system. When the building was moved and raised in 1982-1983, the columns were not plumbed. This omission haunted DYE-2 until abandonment in 1988. Unlike DYE-3, where column tilts were not uniform, at DYE-2 the columns all tilted in one general direction,

causing the structure to become skewed. Although tilt measurements had only been taken on a regular basis since 1986, the data showed a disturbing trend: the columns were leaning at a rate that increased the out-of-plumbness by about 7 cm per year over a 29-m length. The column tilts affected the stresses experienced by the supporting structure in two ways. Axial loads no longer acted along the central axis of the columns, thereby generating moment loads at the base of the column where it attaches to the footing structure. Thus the angle between column and footing tilted. In addition, horizontal stresses are introduced at the truss connections (sway bolt locations) because of twisting forces on trusses. These were the static structural forces that were measured to determine the column stresses.

Finally, as the footings settle and the ice cap drifts (App. A), the columns move differentially with respect to each other (Fig. 10). This differential movement, in addition to the column out-of-plumbness mentioned above, sets up horizontal distortions in the column-truss system that can result in high loads at restraining points at the collars and in the building. High bending moments at the column bases are a result of these large horizontal loads. The horizontal distortion of the truss system may also be the reason why pinching and spreading loads sometimes appeared during sway bolt measurements (described in

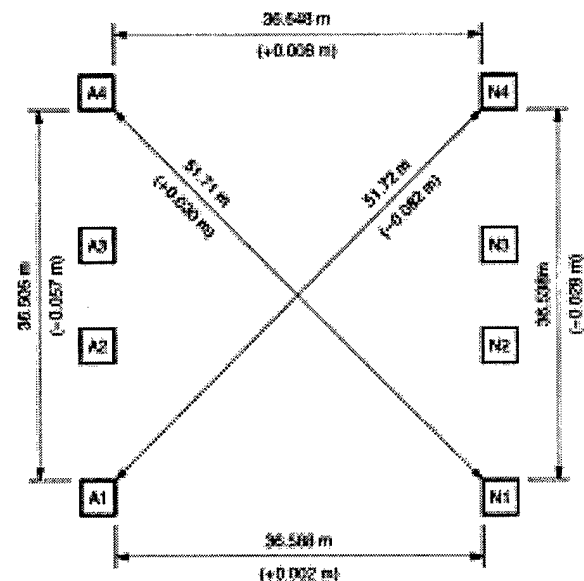
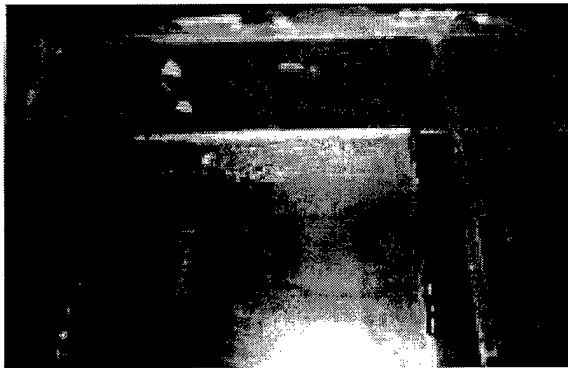

Figure 10. Horizontal movement of columns at snow surface.

the next section). Leuder lines, distortions in the surface of a structural member indicative of localized yielding, were first observed in the supporting structure at the base of the columns below the footing support blocks in early 1988. These Leuder lines were thought to be evidence that high horizontal stresses, and therefore high moments, were being experienced by the columns. An example of Leuder lines is shown in Figure 11, which shows evidence of yielding below the support block of column A3.



a. February 1988.



b. June 1988.

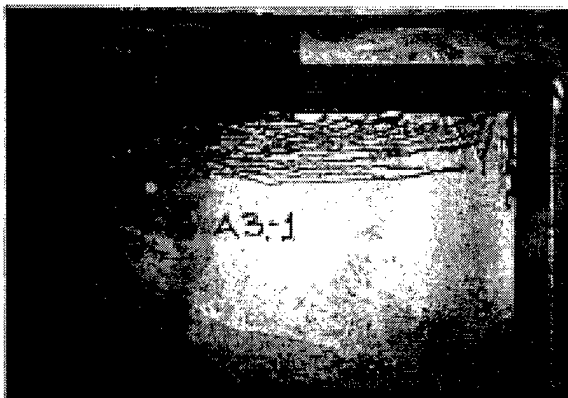

c. August 1988.

Figure 11. Leuder lines: column A base.

In 1987, the column footings were shimmed in an attempt to decrease the amount of column tilt. A secondary purpose of this task was to lower the stresses experienced at the sway bolt locations at the collar levels and in the building. As the rate of tilt was not decreasing, a similar "mini-life-extension" was scheduled for the summer of 1988 to maintain noncritical loads at all column locations. This work was not carried out, and structural stress projections derived from the analysis of data obtained using the measurement techniques and considerations described in following sections resulted in the U.S. Air Force's decision to abandon DYE-2 in late August of 1988. Table 1 contains a chronology of major work performed at DYE-2 since its construction in 1959.

Table 1. DYE-2 milestones.

<i>Year</i>	<i>Event</i>
1959	Original construction on Greenland ice cap
1962	Building raised 1.8 m Truss enclosure extended up
1965	Building raised 2.7 m Truss enclosure extended up
1967	Building raised 3.2 m Truss enclosure extended up
1970	Building raised 7.6 m Subsurface truss added Truss enclosure extended up
1976	Building raised 8.2 m Subsurface truss extended up Truss enclosure and column A1 modified
1982	Building moved to new footings Above-snow trusses constructed
1983	Building raised 8.2 m Column enclosures constructed
1987	Building leveled Column bases jacked and leveled Footings strengthened
1988	Site closed

#### MEASUREMENT CONSIDERATIONS

The stress analysis of the DYE-2 structural system consists of two components. The first component to be considered is the axial load on the supporting columns from the building, the trusses, and the columns themselves. The second component is the horizontal load, derived from the sway bolt measurements taken at the building and collars. The sum of the stresses created by these forces results in the combined stresses,

which were used to determine the structural integrity of the system.

The derivation of the axial load on each column is straightforward. The weight of the building, the weight of the portion of column to the point of measurement (the sway bolt location), and the weight of the truss all contribute to the axial load. Each column theoretically assumes one-eighth of the building load at the second floor level as well as one-eighth of the truss load at the level 3 collar location. Building loads were supplied by the contractor after the 1983 lift and loads at each level were calculated in 1985. Values are given in Table 2. These loads remained constant for calculation purposes throughout the period covered by this report.

The horizontal loads experienced by the building and collars are far more complex. The

Table 2. Column vertical loads.

Level	Column	Load (P) (kN)	$P/A^* = f_a^\dagger$ (kPa)	$f_a/F_a^{**}$
1	A1	1.79	16.55	0.12
	A2	1.79	16.55	0.12
	A3	1.94	17.93	0.13
	A4	1.35	12.41	0.09
	N1	1.35	12.41	0.09
	N2	2.09	19.31	0.14
	N3	1.79	16.55	0.12
	N4	1.79	16.55	0.12
2	A1	1.94	17.93	0.13
	A2	1.94	17.93	0.13
	A3	1.94	17.93	0.13
	A4	1.35	12.41	0.09
	N1	1.35	12.41	0.09
	N2	2.09	19.31	0.14
	N3	1.79	16.55	0.12
	N4	1.79	16.55	0.12
3	A1	1.94	17.93	0.13
	A2	1.94	17.93	0.13
	A3	1.94	17.93	0.13
	A4	1.35	12.41	0.09
	N1	1.49	13.79	0.10
	N2	2.24	20.69	0.15
	N3	1.94	17.93	0.13
	N4	1.79	16.55	0.12
Base	A1	2.09	19.31	0.14
	A2	2.09	19.31	0.14
	A3	2.09	19.31	0.14
	A4	1.49	13.79	0.10
	N1	1.64	15.71	0.11
	N2	2.39	22.06	0.16
	N3	2.09	19.31	0.14
	N4	1.94	17.93	0.13

\* A is axial cross section of column (0.108 m<sup>2</sup>).

†  $f_a$  is the axial stress.

\*\*  $F_a$  is the allowable axial stress with no bending stress (137.9 kPa).

weight of the truss system is supported just below the level 3 collar, the lowest collar level (see Fig. 5). Each column supports on average about 18 tonnes of truss at this collar level. When taking sway bolt measurements at the level 3 collar, resistance to movement from the friction between the trusses and the supporting channel below the collar must be considered. The static coefficient of friction for dry steel on steel is 0.78, resulting in a break-out force of about 140 kN for a 180-kN normal force. After the Teflon/stainless steel bearing pads were inserted at the interface, the static coefficient theoretically should have dropped to about 0.04, with a resulting breakout force of 7.2 kN for the same normal force. However, a drop in lateral resistance due to friction of this magnitude, approximately a factor of 20, did not materialize after installation of the bearing pads. This may have been due to the high loads on the components or the measurement protocol. Therefore, level 3 sway bolt measurements can only be assumed to be approximate.

Another frictional effect to be taken into consideration when determining the horizontal component of the stress is the influence of friction resistance because of loaded bolts located perpendicular to the sway bolt being measured. These bolts reduce the accuracy of the measurements from the constraints they impose on the free movement between the truss and collar. As resistance to movement due to these side loads is experienced when force is applied between the collar and truss during a measurement, the measured loads differ from the actual loads. Thus, sway bolt measurements should be used only as a guide in making an engineering decision on the condition of the structure rather than as an absolute quantity. It is in this manner that CRREL has used the data obtained over the years from sway bolt measurements.

## STRUCTURAL STRESSES

This report includes data and results for comprehensive stress measurements done by CRREL personnel for the years 1983 through 1988. Yearly combined stress factor graphs are included in Appendix B. A complete set of data for the years 1983–1988 can be found in Walsh (1992). Data for 1983 are not complete because the lift operation was not finished at the time measurements were taken. A list of personnel involved in each series of measurements is given in Appendix C. The methodology for obtaining the stress measure-

ments is described in detail in Ueda et al. (1984) and will be briefly reviewed here.

Initially, a survey of all sway bolts is taken, and unloaded sway bolts are backed off so as not to interfere with the measurement of the loaded bolts. At this time, an attempt is made to alleviate all pinching or spreading loads caused by opposing loaded sway bolts at each collar. Pinching loads occur when opposing end or side sway bolts in different column halves are transmitting forces, whereas spreading loads occur when opposing center bolts are loaded (ref., Fig. 8b). Any pinching loads on a single column half are relieved by backing off the least loaded sway bolt.

After completion of the initial survey, the force on each loaded sway bolt is measured using a hydraulic jack and ram and a dial indicator. The ram is placed between the collar and column, adjacent to the sway bolt being checked. The dial indicator is then mounted via a magnetic stand between the column and collar on the side directly opposite the ram. The angular orientation of the sway bolt is marked, and pressure is applied to the ram to unload the sway bolt so it can be backed off. This causes a small horizontal displacement between the column and collar that is displayed on the dial indicator. Ram pressure is reduced until the dial indicator once again reads zero. This is the pressure required for the ram to assume the original sway bolt load. The force can then be easily calculated by multiplying the ram pressure by the piston area.

Ram pressure is then increased and the sway bolt returned to its original position. The sway bolt resumes the load when the ram pressure is released. The dial indicator is checked to see if it has rezeroed. The loaded sway bolts are checked individually and the pressures recorded. When all the loaded sway bolts have been measured, the bolts loosened during the initial survey are lightly tightened against the columns, thus returning the truss system to its original configuration.

Lateral forces can now be determined from the sway bolt pressure measurements. If all the lateral forces on each column except those at the base are known, the base force can be calculated from equilibrium conditions (the forces must balance). Free body diagrams of each column can now be made in two perpendicular directions: across and along the column rows.

Next, treating each column as a cantilever beam (using the base as the ground point and the

building levels the "free" end), the bending moments along each column are calculated in two directions. Axial loads are obtained from the previously described calculations. Axial and bending stresses are then determined. Finally, the combined stress factor is obtained (AISI, 1980) from

$$f_a / F_a + f_{bx} / F_b + f_{by} / F_b \leq 1.0 \quad (1)$$

where  $f_a$  = axial stress (kPa) (from Table 2)

$f_{bx}$  = bending stress in x-direction (kPa)  
(from stress measurements)

$f_{by}$  = bending stress in y-direction (kPa)  
(from stress measurements)

$F_a$  = axial stress permitted if no bending stresses exist (kPa) (from Table 2)

$F_b$  = bending stress permitted if no axial stresses exist (kPa).

This dimensionless equation applies only when the axial stress is 15% or less of the allowable with no bending present (i.e., when  $f_a / F_a < 0.15$ ). The sum of the three quotients results in the combined stress factor, which indicates the supporting framework's structural integrity. From the above equation, the combined stress factors can be seen to incorporate the axial load on the column as well as forces in the two horizontal directions.

The results of the stress measurement surveys are depicted in Appendix B. These graphs give the combined stress factors for each collar level as well as at the base for the years 1983 to 1988. Only the building level measurements were completed in 1983, so stress factors are not correct except at level 1. An average of the overall system is included for reference. A combined stress factor of 1.00 indicates the column has reached the accepted design load. A combined stress factor in excess of 1.60 indicates that the loads and moments exceed safe design limits (yield point). Figure 12 depicts the combined stress factors for the base level (at the column footing) for all five years for which complete data are available. Comparisons of the bar graphs for the combined stress factors in this figure show great variability in both the columns for any given year and the factors for any given column from year to year. Inspection of the data, however, indicates that a load pattern develops over time.

In 1984, after the building was moved and raised, stress levels were relatively uniform and

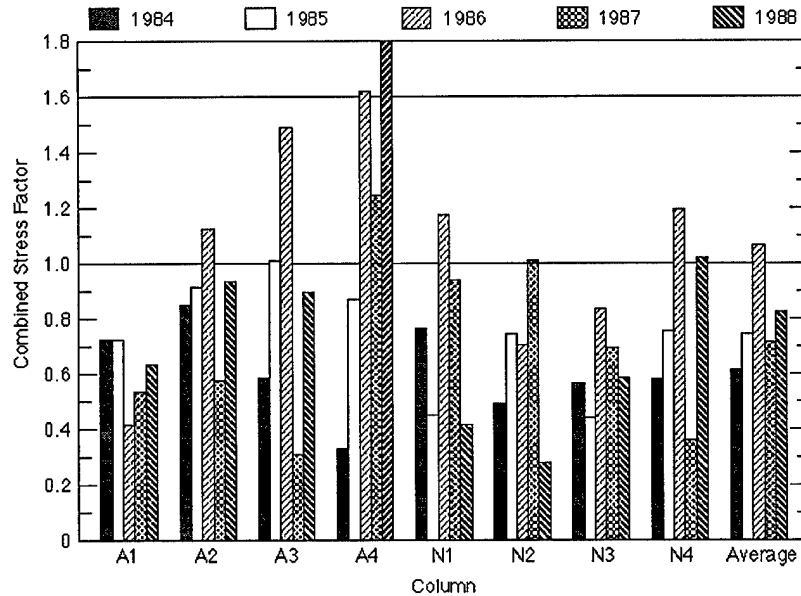

Figure 12. Summary of base level stress concentration factors: 1984-1988.

low, with an average base level combined stress factor (BLCSF) of about 0.61. BLCSFs are calculated loads on the column bases caused by stresses measured in the four collars of each column. There is no obvious pattern to the stress levels. None of the column BLCSFs exceed 1.00. In 1985, the stresses have become redistributed. The average BLCSF has increased to 0.71, with one column exceeding 1.00. Again, no pattern is obvious, although the A row is more heavily loaded than the N row.

By 1986, a pattern has emerged. In the A row, the BLCSFs steadily increase from A1 to A4. The same applies to the N row with the exception of N1. The A row is more heavily loaded than the N row, as was seen in 1985. The columns contained by the rear truss system (A3, A4, N3, N4) have higher BLCSFs than their counterparts contained by the forward truss system. The loads are significantly higher than in 1985. Five columns have a BLCSF in excess of 1.00, with A4 at 1.62. The average BLCSF also exceeds 1.00, up 36% from 1985 to 1.07.

With the column bases jacked and releveled and the building and trusses releveled in 1987, we see a general decrease in stress factors. The average BLCSF drops from 1.07 to 0.71, a decrease of over 33%. Only two-column BLCSFs now exceed 1.00. Column A4, which was at 1.62, has dropped to 1.24, a decrease of 23%. The two truss systems are now more evenly loaded. The stress pattern seen in 1985 and 1986 has disappeared, with the exception that A4 is still highly loaded. The data

for 1988 show a return to the previously developed stress pattern. The average BLCSF has increased to 0.82, up over 15% from 1987 but still below 1986. The A row columns are much more highly loaded than the N row and the rear truss system is more highly loaded than the forward. The stress factor for A4 has increased from 1.24 to 1.80, or 45%. Columns A3 and A4 have both increased over 60%. Two column BLCSFs exceed 1.00, while two more are rapidly approaching 1.00.

From the data on hand, a predictable pattern has emerged. When the column bases and building/truss system are leveled, a general reduction and redistribution of stresses occurs. Following these operations, the base level combined stress factors along the A row increase faster than along the N row, the rear truss system columns become more highly loaded than those contained by the forward system, and column A4 develops significant base level stresses. The driving force for the stress increases, and the persistent stress pattern may be column footing settlement and tilt, which will be examined next.

## FOOTING SETTLEMENTS AND TILTS

Footing settlement has been measured on a regular basis since the move in 1982. This has usually been the responsibility of the CRREL survey team with assistance from the stress measurement team. The causes of footing settlement have been mentioned in the *Structural Influences* section and will be reviewed in more detail here.

The four most probable causes of footing settlement are viscous flow or densification of the subfooting snow as a result of the weight of the building, mixed matrix composition of the supporting snow, the influence of the presence of meltwater and runoff in and around the footing enclosures, and differences in overburden pressure of the surrounding snow. All four of these conditions existed to various degrees at DYE-2 during the time span under consideration. Uniform settlement of the building and structure is not as serious a problem as differential settlement, and so was not considered an important factor contributing to the generation of stress in the structure. Differential settlement, such as that caused by an inhomogeneous snow matrix, meltwater pooling in the footings, variable densification of the supporting snow, and uneven loading, was of more concern because it would likely result in the generation or exacerbation of stresses in the supporting structure.

All footing settlements were measured relative to the footing below column A4. In 1982, after DYE-2 was moved, the footings were all the at the same elevation. Settlements were measured using a transit on the snow surface below the building, a tape measure to measure the dis-

tance from the footings to the top of the enclosure, and a surveyor's rod to tie the enclosure top of footing A4 using the transit. The tape length was corrected for temperature effect ( $11.61 \times 10^{-6}$  cm/cm $^{\circ}$ C).

Measuring footing tilts was also a task normally assigned to the survey team. For those measurements, a self-leveling level was mounted on a special monopod mount and used to determine elevations to the nearest 0.2 cm at four fixed points at the footing corners. The level was located on the centerline of the footing and the four points at the corners of the footing referenced to this point. This point was also used as the footing settlement datum point for each column. Elevations for the four points were recorded and rechecked. Calculations for tilts along and across the columns were later made using these data. Data for settlement and tilts can be found in Walsh (1992).

Footing settlements at DYE-2 were very linear. Table 3 indicates linear correlation coefficients greater than 0.985 for all columns for the years 1982 through 1988. Averaged coefficients are greater than 0.995. This signifies a very high degree of correlation and thus indicates that the footings are settling in a linear manner, although

Table 3. Footing settlements (centimeters).

<i>Year/Column</i>	<i>A1</i>	<i>A2</i>	<i>A3</i>	<i>A4*</i>	<i>Average</i>
A-side data					
1982	0	0	0	0	0
1983	8.2	5.8	3	0	5.7
1984	15.8	10.4	4.9	0	10.4
1985	21.3	15.2	6.1	0	14.2
1986	29.6	18.9	10.4	0	19.6
1987	35.1	22.6	12.2	0	23.3
1988	41.8	25.6	14	0	27.1
Rate (cm/yr)	6.89	4.25	2.35	0	4.5
Correlation	0.9972	0.9897	0.9851	N/A	0.996
	<i>N1</i>	<i>N2</i>	<i>N3</i>	<i>N4</i>	<i>Average</i>
N-side data					
1982	0	0	0	0	0
1983	9.1	8.2	6.7	3	6.75
1984	19.8	17.1	14.3	6.4	14.4
1985	29.9	25	22.9	11.3	22.28
1986	41.1	34.1	28.7	15.8	29.93
1987	51.8	43	36	20.4	37.8
1988	61.3	52.4	44.2	26.8	46.18
Rate (cm/yr)	10.38	8.71	7.34	4.45	7.72
Correlation	0.9994	0.9995	0.9987	0.9886	0.9993

\* A4 is reference footing and not included in averages, rates, or linear correlation factor calculations

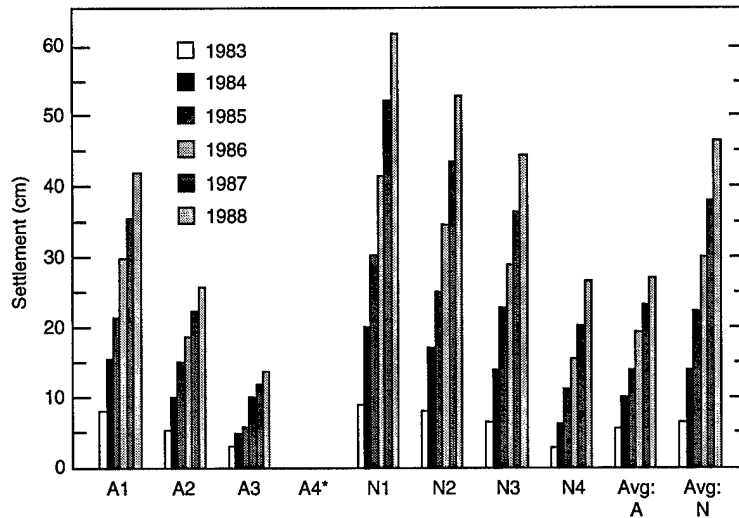

Figure 13. Footing settlements: 1982-1988.

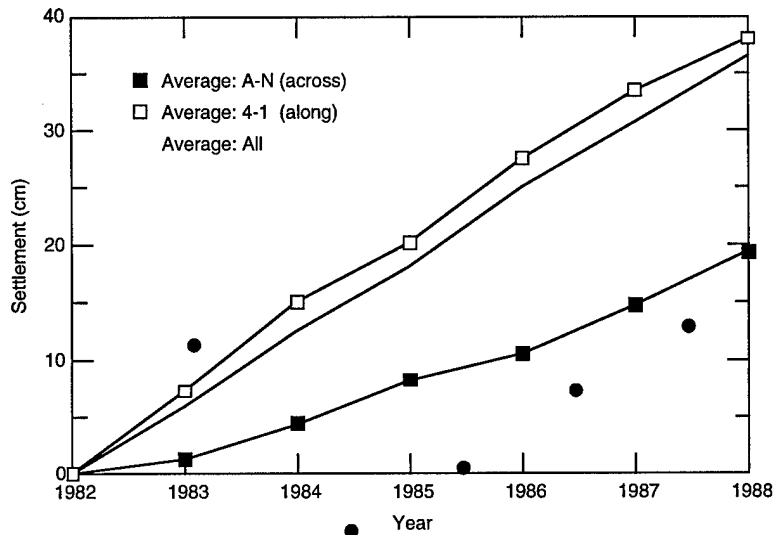

Figure 14. Footing settlement trends.

at differing rates. Figure 13 shows the settlements of the A and N row of columns, as well as the averages of each respective row. Footing A4 was used as the datum point as this was the slowest settling footing and was used as the "baseline" footing previous to the move in 1982. Therefore no settlements are given for it.

From these figures, several observations can be made. The most obvious is that the N row is settling faster than the A row. The average rate of settlement of the N row with respect to A4 is 0.08 m/year. The settlement of columns A1 through A3 with respect to A4 is only 0.05 m/year. Footing settlement data can be found in Walsh (1992).

The across-row settlement as well as the along-row settlements for both rows show similar trends. Figure 14 shows these settlements for the years 1982 to 1988. Along-row settlements were normalized to A4 and N4 for their respective

rows while across-row settlements were normalized to the A row. One important note to make here is that in August of 1988 approximately 2 m (6 ft) of water and ice was present in footing N1 (Fig. 15). This was an accumulation of over a meter (4 ft) since June of that year. The effect of the presence of this much water in the column footing may have led to weakening of the underlying packed snow foundation or even voids, depending on the amount of heat given off during the transformation of the water to ice and the contribution of the structural members within the footings to the dissipation of this heat. As the mean annual temperature at DYE-2 is around  $-16.6^{\circ}\text{C}$ , there is a good chance some melting of the foundation may have occurred. However, with no borings conducted to verify this hypothesis, we can only postulate that the foundation was adversely affected by the presence of this water.



Figure 15. Flooding of footing N1, August 1988.

The settlement of the footings will have an effect on the horizontal forces experienced by the trusses and supporting columns in two ways. The first is through uneven loading of the columns. Graduated settlement, as seen at DYE-2, results in the structure leaning in the direction of the lowest footings. This will cause column tilt and nonaxial loading of the columns. The result is the generation of large moments at the column bases, which will be discussed in more detail in the next section.

The second factor is horizontal loads on the columns caused by canting of the truss system. If we look at the rear truss which joins columns A4,

A3, N3, and N4, we can see how this happens. As A3, N3 and N4 settle relative to A4, the building and truss also settle with respect to A4 at those locations. From Figure 14, the direction and magnitude of the footing tilts averages approximately  $300^\circ$  and 0.014 radians, respectively. The highest loads in the building and truss levels should then be at A4 with intermediate loads at A3 and N4 and the lowest loads at N3. The horizontal loads should be greatest where the settlement is least. Data taken during the 1988 field work confirm both conditions. This also applies to the forward truss.

It is interesting to note that after the 1987 mini-extension and plumbing operation, the base level moments decreased on average about 36% (Fig. 12) and the stresses were redistributed. Some of this may be due to the releveled of the trusses. The distribution of the base level stresses are similar in 1986 and 1988, when stresses were high. However, they do not correlate as well for 1985 and do not correlate at all for 1984, which is the year following the last major lifting and leveling operation. The pattern is clear, though. When the building and trusses were releveled, the stresses were reduced and redistributed. As the footings continue to settle, a loading pattern starts to develop within the two truss systems and the corresponding building sections. Both truss systems eventually become highly loaded in their north-

Table 4. Footing tilts and resultants.

Footing	Attribute	1982	1983	1984	1985	1986	1987	1988
A1	Resultant	0.00062	0.0019	0.00522	0.00685	0.00894	0.01023	0.01244
	Direction	105.8	357.0	347.7	336.1	330.6	326.9	322.8
A2	Resultant	0.00167	0.00441	0.00735	0.00973	0.01195	0.01378	0.01739
	Direction	226.0	226.1	287.4	291.7	294.3	294.9	293.8
A3	Resultant	0.00265	0.00408	0.00540	0.00770	0.00983	0.01153	0.01418
	Direction	190.0	234.0	272.4	283.9	287.8	290.0	291.6
A4	Resultant	0.00096	0.00150	0.00378	0.00584	0.00793	0.00968	0.01112
	Direction	252.5	266.2	293.6	299.8	303.7	305.0	306.1
N1	Resultant	0.00130	0.00408	0.00615	0.00841	0.00982	0.01105	0.01314
	Direction	84.7	17.1	356.1	352.8	343.1	336.6	335.3
N2	Resultant	0.00103	0.00281	0.00517	0.00743	0.00921	0.01122	0.01345
	Direction	80.5	355.9	336.9	331.0	326.2	325.2	323.6
N3	Resultant	0.00233	0.00789	0.01102	0.01349	0.0153	0.01782	0.02106
	Direction	336.7	377.6	343.0	339.4	336.4	335.5	336.0
N4	Resultant	0.00075	0.00474	0.00899	0.01254	0.01549	0.01863	0.02363
	Direction	292.8	332.4	325.7	322.6	321.8	320.5	320.8
Average	Resultant	0.00141	0.00393	0.00664	0.00900	0.01106	0.01299	0.01580
	Direction	196.1	270.8	320.4	319.7	318.0	316.8	316.3

Notes: Resultants in radians from center of footings.  
 Coefficient of linearity of averages for resultants is 0.9974.  
 Direction is clockwise from line parallel to direction from N4 to A4 (see diagram).

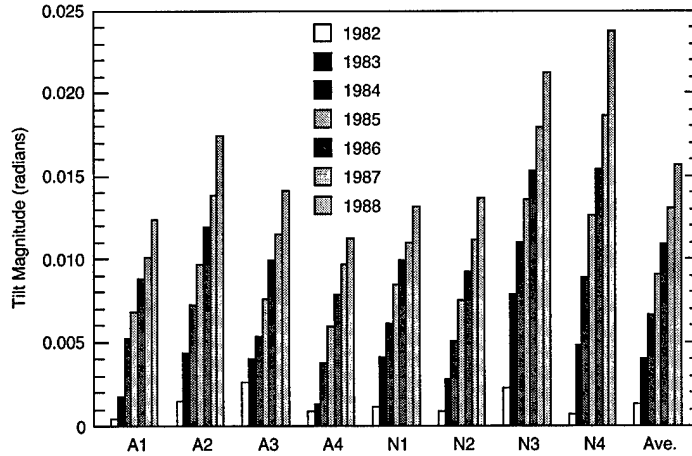

Figure 16. Footing tilts: 1982-1988.

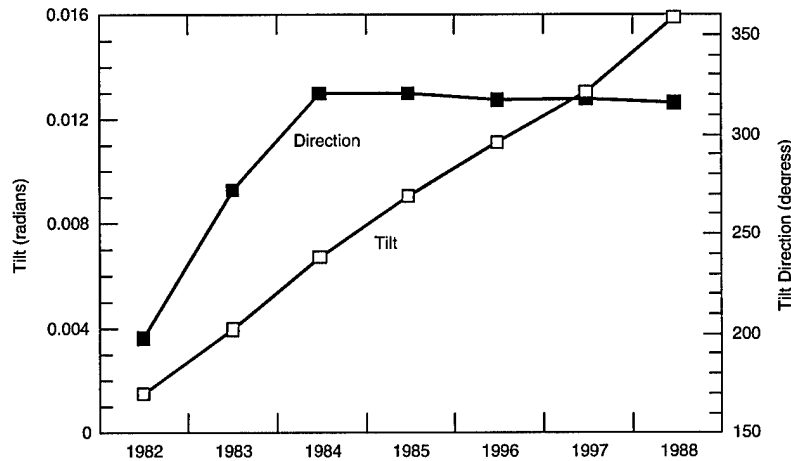

Figure 17. Footing tilt trends.

ern corners (A4 and A2), with the rear truss system (the A4 system) the more heavily loaded. This ultimately affects the base level stress factors.

Footing tilts correlated remarkably well with the settlement data at DYE-2. Table 4 contains resultants and directions for the footing tilt data for the years 1982 through 1988 for each column. Also included are the averages for all columns for each year. This is depicted graphically in Figure 16. Comparing Figure 13 to the data in Table 4 and Figure 16 shows that the footings are tilting in almost the same direction with the same magnitude as the columns: in a direction of  $313^\circ$  with a magnitude of approximately 0.015 radians. These values are too close to be coincidental. The rates of change are also very similar, approximately 0.0025 radians per year. Statistical analysis of the resultant averages shows a very high degree of linearity in the tilt progression:  $>0.997$ .

Figure 17 shows trends for the average tilt and direction for the footings. These should be compared to the footing settlement trends in Figure 14.

Analysis of the data for these two parameters as well as their rates of increase leads to the hypothesis that the footings settled in a manner such that they were causing the structure to lean roughly from A4 to N2 in the N2 direction.

## COLUMN TILTS

Column tilt measurements were only taken for two years: 1987 and 1988. No data are available for the original column tilts after the relocation of the DYE-2 site. During the period from May 1987, prior to the column bases being jacked and leveled, and August 1988, four complete sets of measurements and one partial set of measurements were taken. The data are presented in Table 5.

Measurements were taken inside the north flange between column pairs, where possible. Because of interference problems, each measurement consists of three parts: within the building, between the building and the column enclosures, and inside the column enclosures. The sum of the

Table 5: Column tilts.

Column	Direction	Column tilts (cm)				Average resultant	Average direction (°)
		July 1987	September 1987*	February 1988	August 1988		
A4	Along	32	24	33	33	38	306
	Across	24	19	21	25		
A3	Along	33	33	30	35	42	308
	Across	27	22	24	29		
A2	Along	27	22	17	23	36	322
	Across	32	24	27	29		
A1	Along	19	14	15	16	32	330
	Across	30	24	26	29		
N4	Along	37	29	20	30	33	298
	Across	17	11	16	16		
N3	Along	23	25	20	28	29	305
	Across	22	14	14	17		
N2	Along	15	15	17	19	26	321
	Across	18	17	23	23		
N1	Along	15	9	20	15	25	323
	Across	25	13	17	24		
Average	Along	25	21	22	25	32	313
	Across	24	18	21	24		
Avg. resultant (cm)		35	28	30	35	32	
Avg. direction (°)		314	310	314	314		313
Avg. tilt (radians)		0.019	0.015	0.017	0.019		(-0.017)

\*Middle section of column only.

displacements divided by the measurement length appears in the data figures. A plumb bob hanging from a magnetically mounted reel was used in conjunction with a measuring tape to find the vertical position of the data points as well as the two horizontal displacements. The data for September 1987 were for the section between the building and enclosures only.

Because so few data are available for the column tilts, it is difficult to draw any hard conclusions. Several points are worth noting from the data that are available, however. The first is that the columns are tilting in the same general direction and with the same magnitude as the progression of the footing and column settlements for all data sets. A second point is that the magnitude of the lean seems to correlate with the base level stress factors (Table 5 and Fig. 12). The data for September 1987 are not complete, which may be why the data do not correlate as well as that of August 1988. A third point is that after an initial rapid increase in tilt following the shimming operation in 1987, the rate of tilt leveled off to an average of about 0.3 in. per 10 ft/year (0.25 cm/m-yr) (Fig. 18). We do not have a large enough database to confirm points 2 and 3, but the trends are present and worth mentioning.

## DISCUSSION

During the sway bolt surveys in 1987 and 1988, concerted efforts were made to remove any pinching or spreading loads at each collar level. These opposing loads serve no structural purpose, so in those years, most were eliminated. Sway bolts all around the column collars were brought to bear against the column to ensure no looseness in the structure after pinching and spreading loads were relieved.

On some collars, normal sway bolt measurements could not be taken. The reasons were either bad sway bolts that could not be turned (heads missing, weld metal on threads, distorted threads, etc.) or sway bolts that had been turned all the way into their nut blocks. When this occurred, a load-deflection measurement had to be performed. To conduct a measurement, a deflection is measured for specific loads applied between the column and collar opposite the dial indicator. An example of a load-deflection measurement is shown in Figure 19. Although not highly accurate due to the influence of such uncontrollable factors as friction loads and the effect of adjacently loaded sway bolts, this measurement procedure gives approximate loads through linear extrapolation sufficient for analysis.

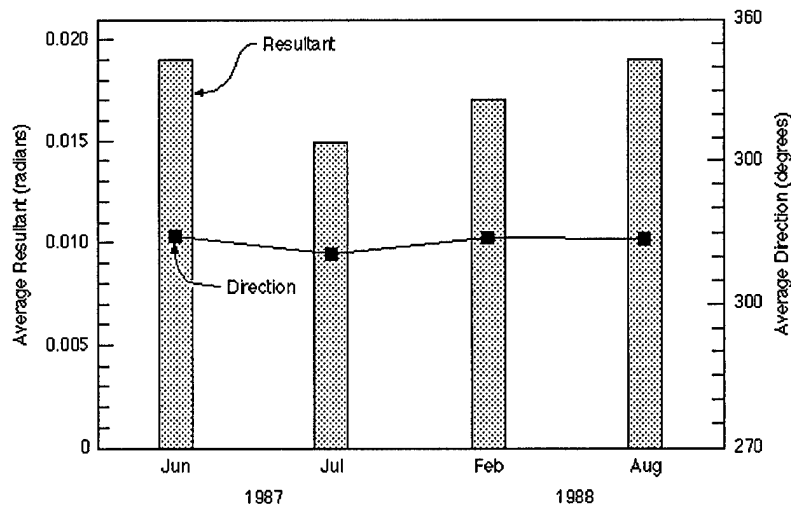

Figure 18. Column tilt trends.

Force imbalances still existed on the free-body diagrams (Walsh 1992), despite the use of friction-reducing bearing pads and the attempts to reduce opposing loads. In addition to the frictional load from the weight of the truss on the truss support bearing, the frictional forces due to loaded sway bolts 90° from the sway bolt being measured must also be considered. For a side load of 44.5 kN (10 kips), the resulting breakout force is 34.7 kN (7.8 kips) and the sliding force would be 25.3 kN (5.7 kips). The presence of one highly loaded bolt on a collar can thus greatly affect the readings derived from bolts with smaller loads on the same collar level. From a

quick analysis of imbalances present in the truss systems in 1988, the magnitudes of these imbalances were not of the order witnessed in previous years. These lower figures increased the probability of accuracy for the 1988 readings, which were used by the CRREL engineers in formulating their opinion of the structural safety for building occupancy and projections of structural stresses at DYE-2 for the Air Force.

Analysis of the data collected for all aspects of the system indicate an inexorable tilt of the structure along with related structural stress increases. The direction of tilt is towards the "warm" southwest corner of the building. The highest

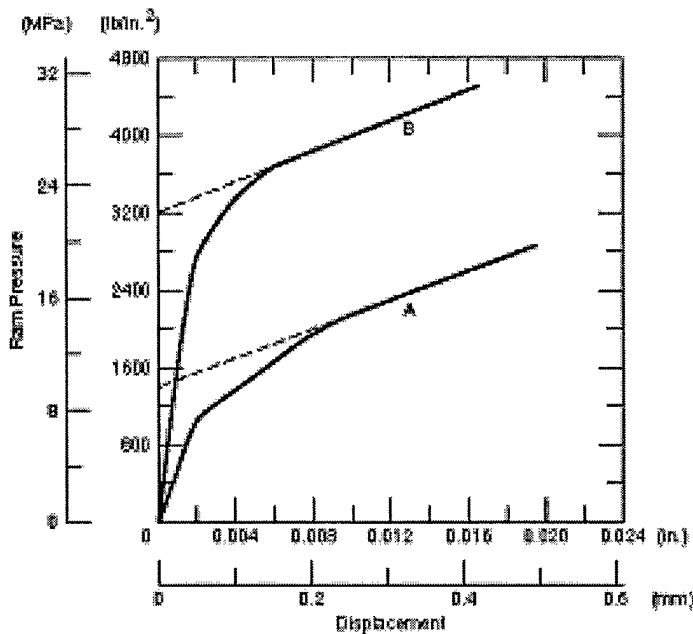

Figure 19. Example of load (pressure)-displacement measurement.

base level column load can be found in the opposite corner, at column A4. The presence of a large quantity of water at the base of column N1, covering the footing to a depth of several meters, indicates melting of surface and structural snow and subsequent runoff and collection in the column enclosures. These factors may indicate the cause of the tilt problem at DYE-2: changing snow conditions at the base of the "warm" side footings due to the presence of meltwater. Warmer conditions and the presence of water at the bases of these columns would cause melting or increased densification of the snow beneath these footings, which in turn would undermine the support these columns contribute to the structure. This would contribute to or even cause the differential settlement rates, column and footing tilts, and stress distribution patterns found at DYE-2.

### CLOSURE OF DYE-2

In July of 1988, funds for a second leveling operation entailing work similar to that done in 1987 were withdrawn. On 29 July, it was agreed that CRREL would "... remeasure stresses in the DYE-2 frame and re-examine the bearing blocks for further signs [of buckling failure] as soon as possible ..." (Tobiasson 1988). On 18 August, a CRREL team accompanied by Stewart Osgood of Metcalf & Eddy, Inc., arrived at Sondrestrom Air Force Base. On 20 August field work began at DYE-2. Sway

bolt loads were measured, column tilts obtained, and bearing block supports visually inspected. Footing settlements and tilts had been measured in June during previous field work.

From data available from both the June and August work, as well as previous years' work, the following conclusions were drawn:

- High stresses were present in the structure, especially along column A4. These stresses were approximately the same as those predicted in the justification for the second mini life extension.
- Extrapolation of the stress data shows an increase in stress beyond a factor of 2.0 (the upper design safe level) before the end of 1988.
- Column tilts were continuing at about the amount predicted earlier ( $\approx 0.25 \text{ cm/m} \cdot \text{year}$ ).
- Footing settlements continued to be a problem. Settlement was linear over the span of time under consideration and showed no indication of slowing. N1 was of special concern due to the amount of water and ice present in the footing room ( $\approx 2 \text{ m}$ ).
- Footing tilts continued to increase as expected.
- There had been no significant increase in stress-induced Leuder lines in the bearing block supports on all column footings since June of 1988 (2 months). This was a qualitative assessment and indicated no further yielding in the supporting structure at the column bases over the summer. Later examination of photographic data showed

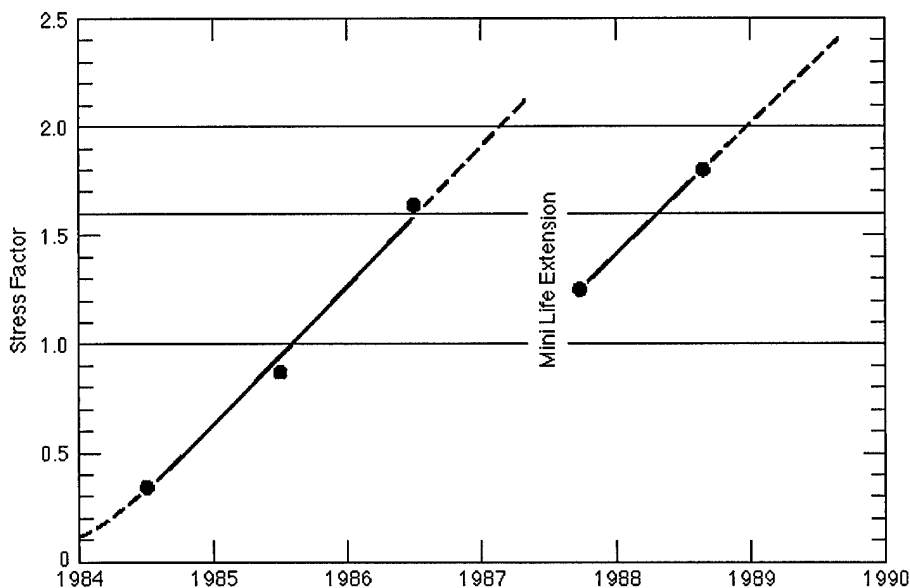

Figure 20. Extrapolation of base level combined stress factors for column A4.

no increase in Leuder lines since the mini-life-extension operation in mid-1987, leading to the conclusion that the yielding had occurred during that work and not afterwards as previously thought.

Extrapolation of the data for the column tilts (Fig. 18) and the base level combined stress factors for column A4 (Fig. 20) led the CRREL and Metcalf & Eddy engineers to conclude that the station could be safely occupied until 1 October 1988. Adjustment and monitoring of the sway bolt loads may have extended this period until 31 December 1988. The Air Force, using this analysis and the conclusions and options drawn from it, closed the site in August of 1988, shortly after the conclusion of our work. Monitoring of the Greenland sector of the DEW line was assumed by the new radar facility at Thule, Greenland.

#### LITERATURE CITED

- Haynes, F.D. (1988) Vibration analysis of a DEW line station. In *Proceedings of the Sixth International Modal Analysis Conference, 2-4 February, Orlando, Florida*, Union College, Schenectady, New York.
- Osgood, S., and D. Bornstein (1989) DYE-2 and DYE-3: A 30-year engineering history. In *Cold Regions Engineering: Proceedings of the Fifth International Conference* (R.L. Michalowski, Ed.), 6-8 February, St. Paul, Minnesota.
- Tobiasson, W., H.T. Ueda, and G. Hine (1974) Measurement of forces within the structural frame of DEW line icecap stations DYE-2 and DYE-3. USA Cold Laboratory, Special Report 81-3.
- Ueda, H.T., W. Tobiasson, D. Fisk, D. Keller, and C. Korhonen (1984) Secondary stresses associated within the structural frame of DYE-3: 1978-1983. USA Cold Regions Research and Engineering Laboratory, Special Report 84-26.
- Walsh, M.R. (1992) Data used in the structural analysis of DYE-2: 1983-1988. USA Cold Regions Research and Engineering Laboratory, Internal Report 1101.
- DYE-2 LITERATURE**
- The following is a list of CRREL documents available on the subject of DYE-2. Not all of the following items were cited in the preceding report. They are included here for reference as this is the last report to be written for this era of the station. Cited literature will be noted.
- Black, R., J. Lowry, and W. Tobiasson (1968) 1968 performance survey of DEW line icecap stations DYE-2 and DYE-3. USA Terrestrial Sciences Center, Special Report to U.S. Air Force.
- Flax, D., G. Hine, W. Tobiasson, and B. Whistler (1971) 1971 performance survey of DEW line icecap stations DYE-2 and DYE-3. USA Cold Regions Research and Engineering Laboratory, Special Report to U.S. Air Force.
- Lowry, J., L. Smith, and W. Tobiasson (1969) 1969 performance survey of DEW line icecap stations DYE-2 and DYE-3. USA Cold Regions Research and Engineering Laboratory, Special Report to U.S. Air Force.
- Reed, S.C. (1966) Performance study of the DEW line icecap stations, Greenland, 1963. USA Cold Regions Research and Engineering Laboratory, Special Report 72.
- Smith, L., W. Tobiasson, and B. Whistler (1970) 1970 performance survey of DEW line icecap stations DYE-2 and DYE-3. USA Cold Regions Research and Engineering Laboratory, Special Report to U.S. Air Force.
- Tobiasson, W., and H.T. Ueda (1972) Instrumentation of the structural frame of DEW line icecap stations DYE-2 and DYE-3. USA Cold Regions Research and Engineering Laboratory, Special Report to U.S. Air Force DEW Systems Office.
- Tobiasson, W., and P. Tilton (1980) Extending the useful life of DYE-2 to 1986. Part 2: 1979 findings and final recommendations. USA Cold Regions Research and Engineering Laboratory, Special Report 80-13.
- Tobiasson, W., C. Korhonen, and R. Redfield (1979) Extending the useful life of DYE-2 to 1986, Part 1: Preliminary findings and final recommendations. USA Cold Regions Research and Engineering Laboratory, Special Report 79-29.
- Tobiasson, W., H.T. Ueda, and G. Hine (1974) Measurement of forces within the structural frame of DEW line icecap stations DYE-2 and DYE-3. USA Cold Regions Research and Engineering Laboratory, Special Report 205. (Cited in this report.)
- Tobiasson, W., G. Hine, K. Muller, and A. Bailey (1972) 1972 Performance survey of DEW line icecap stations DYE-2 and DYE-3. USA Cold Regions Research and Engineering Laboratory, Special Report to U.S. Air Force DEW Systems Office.
- Tobiasson, W., G. Hine, R. Redfield and W. Blanchard (1975) 1973 Performance survey of DEW line icecap stations DYE-2 and DYE-3. USA Cold Regions Research and Engineering Laboratory, Special Report 228.
- Ueda, H.T., M.A. Goff, and K.G. Nielson (1981) An investigation of the snow adjacent to DYE-2, Greenland. USA Cold Regions Research and Engineering Laboratory, Special Report 81-3. (Cited in this report.)

## APPENDIX A: MOVEMENT OF DYE SITES ON GREENLAND ICE CAP

Figure A1 depicts the relative movement of DYE-2 and DYE-3 in relation to each other and their original positions in 1959. Movement upon the icecap does not necessarily mean distortion of the surface layers, as was seen in the reopening of the borehole at Camp Century in northern Greenland after many years of nonuse. Figure A1 is included primarily as a reference.

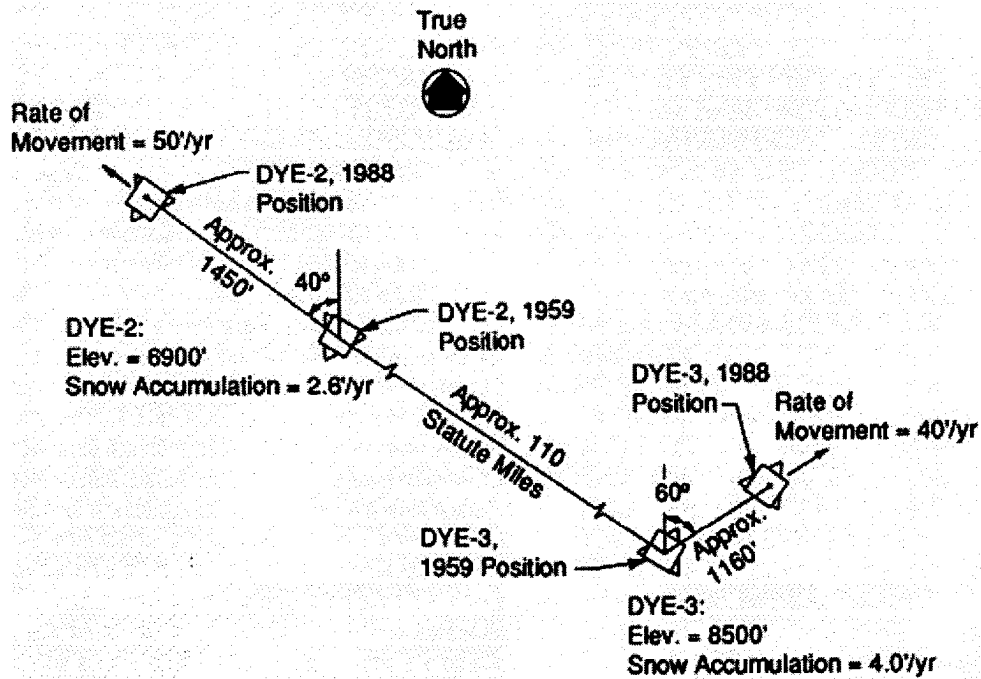

Figure A1. Movement of DYE Sites on Greenland Icecap, 1959–1988 (from Osgood and Bornstein 1988).

**APPENDIX B: SUPPORTING  
STRUCTURE STRESS  
MEASUREMENT DATA, 1983-1988**

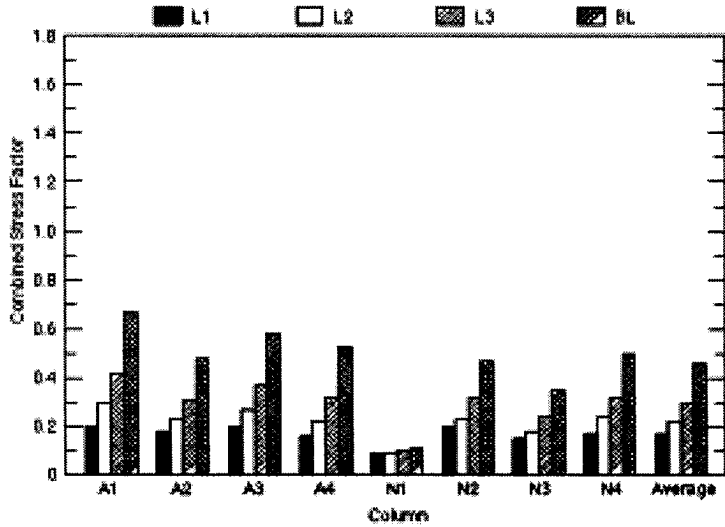

Figure B1. Swaybolt loads: 1983.

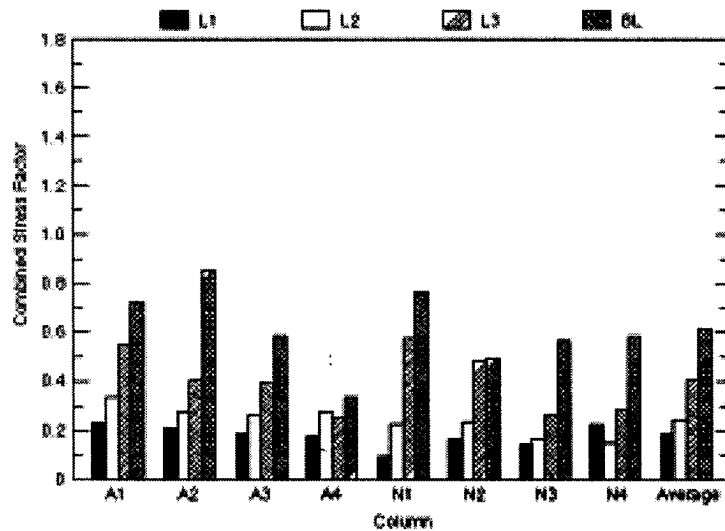

Figure B2. Swaybolt loads: 1984.

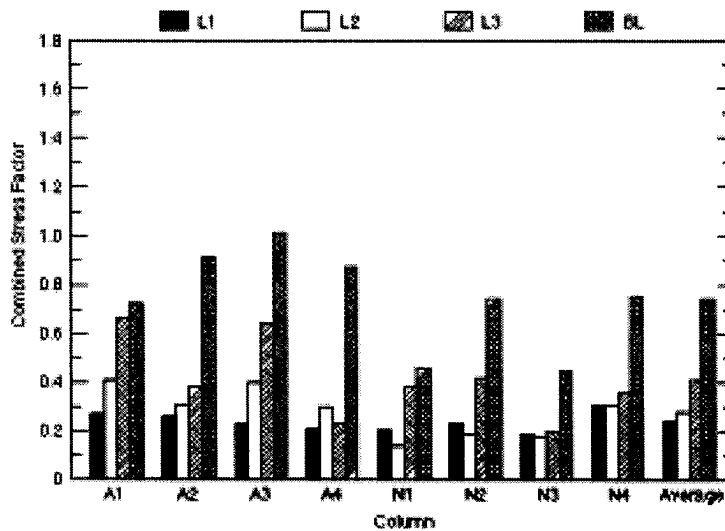

Figure B3. Swaybolt loads: 1985.

Figure B1 contains sway bolt data for the building level only. At the time readings were taken, work was not complete on the 1983 lift operation. Stress factors for other levels are extrapolations from the building level stresses.

Figure B2 contains the second complete set of combined stress factors since the move in 1982.

Figure B3 contains the second complete set of combined stress factors since the move in 1982.

Figure B4 contains the third complete set of combined stress factors since the move in 1982. It is interesting to compare stress factors for 1984 through 1986 for trends. High stress concentration factors in general, and especially at column A4 (>1.60), led to a recommendation that work be contracted for the next summer to alleviate some of the high stresses. Column tilts were also a factor in this decision.

Figure B5 contains the fourth complete set of combined stress factors since the move in 1982 and the first since the mini-life-extension of 1987. Comparing stress factors for 1984 through 1987 points up several trends that are more obvious when examining Figure 12. Although the mini-life-extension served to lower most stress and redistribute stresses among the columns in general, trends dictated a repeat of the work performed in 1987 to assure the structural integrity of the building. Another mini-life-extension was therefore recommended for 1988.

Figure B6 contains the final complete set of combined stress factors calculated for DYE-2 and the second since the mini-life-extension of 1987. Comparing stress factors for 1984 through 1988 points up several trends which are more obvious when examining Figure 12. Although the mini-life-extension was recommended for the summer of 1988, funding difficulties were encountered and the work was

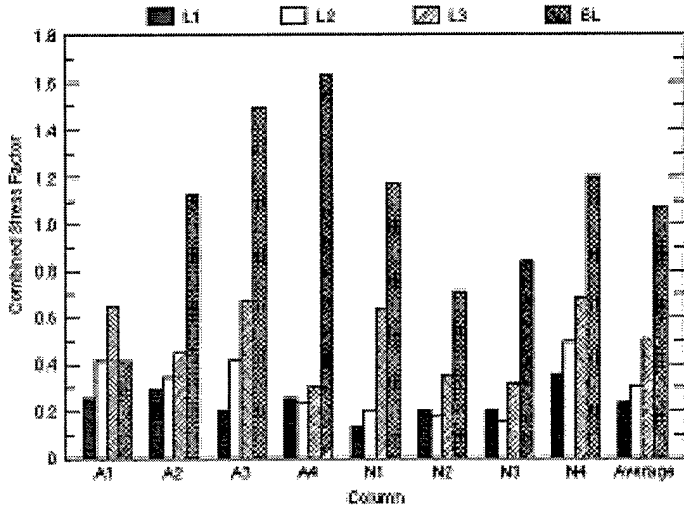

Figure B4. Swaybolt loads: 1986.

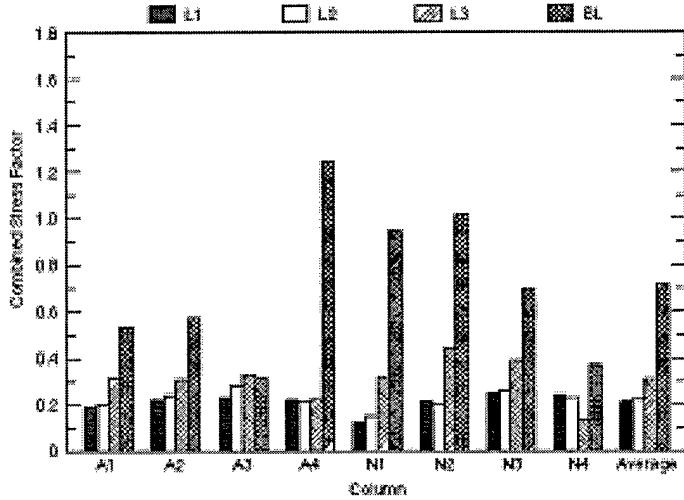

Figure B5. Swaybolt loads: 1987.

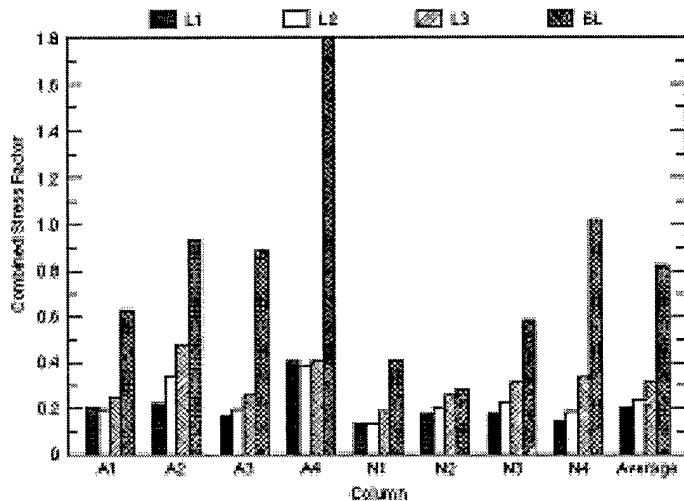

Figure B6. Swaybolt loads: 1988.

not done. From the data, one can see a rise in the general state of stress in the structure, especially in column A4, which has a combined stress factor well in excess of 1.60. Extrapolation of this and previous years' data indicated a combined stress factor of more than 2.00 by year's end (Fig. 20).

### APPENDIX C: FIELD PERSONNEL, 1983-1988

Table C1 contains a list of CRREL personnel involved in the field work necessary to gather the data for this report. Where appropriate, teams are divided according to tasks assigned. Students are signified by (s). Stuart Osgood of Metcalf & Eddy (M&E), who participated in several trips as a student for CRREL, is included in the final trip in 1988 in recognition of his significant contributions to that trip.

**Table C1. CRREL Field Personnel at DYE-2, 1983-1988.**

<i>Year</i>	<i>Dates</i>	<i>Personnel</i>		
1983	2-6 August	J. Bouzoun H. Ueda	C. Korhonen D. Keller	K. Kaufman
1984	18-22 June	C. Korhonen M. Irmen	H. Ueda J. Hepler	M. Harrington (s) W. Tobiasson
1985	17-20 June	H. Ueda D. Boggs W. Tobiasson	D. Keller M. Mauser	S. Osgood (s) J. Farnwald
1986	16-22 June	H. Ueda W. Matott	J. Stark W. Tobiasson	S. Osgood (s) M. Harrington (s)
1987	10-16 September	M.R. Walsh B. Young	H. Ueda	R. Caron
1988	9-11 June	W. Tobiasson	S. Stevens (s)	A. Olmstead (s)
	18-25 August	M.R. Walsh	H. Ueda W. Tobiasson	S. Osgood (M&E) B. Young

# REPORT DOCUMENTATION PAGE

Form Approved  
OMB No. 0704-0188

Public reporting burden for this collection of information is estimated to average 1 hour per response, including the time for reviewing instructions, searching existing data sources, gathering and maintaining the data needed, and completing and reviewing the collection of information. Send comments regarding this burden estimate or any other aspect of this collection of information, including suggestion for reducing this burden, to Washington Headquarters Services, Directorate for Information Operations and Reports, 1215 Jefferson Davis Highway, Suite 1204, Arlington, VA 22202-4302, and to the Office of Management and Budget, Paperwork Reduction Project (0704-0188), Washington, DC 20503.

1. AGENCY USE ONLY (Leave blank)		2. REPORT DATE June 1998	3. REPORT TYPE AND DATES COVERED	
4. TITLE AND SUBTITLE Structural Analysis of DEW Line Station DYE-2, Greenland: 1983-1988			5. FUNDING NUMBERS	
6. AUTHORS Michael R. Walsh and Herbert T. Ueda				
7. PERFORMING ORGANIZATION NAME(S) AND ADDRESS(ES) U.S. Army Cold Regions Research and Engineering Laboratory 72 Lyme Road Hanover, New Hampshire 03755-1290			8. PERFORMING ORGANIZATION REPORT NUMBER CRREL Report 98-3	
9. SPONSORING/MONITORING AGENCY NAME(S) AND ADDRESS(ES) U.S. Air Force Washington, D.C. 20330			10. SPONSORING/MONITORING AGENCY REPORT NUMBER	
11. SUPPLEMENTARY NOTES For conversion of SI units to non-SI units of measurement consult <i>Standard Practice for Use of the International System of Units (SI)</i> , ASTM Standard E380-93, published by the American Society for Testing and Materials, 1916 Race St., Philadelphia, Pa. 19103.				
12a. DISTRIBUTION/AVAILABILITY STATEMENT  Approved for public release; distribution is unlimited.  Available from NTIS, Springfield, Virginia 22161.			12b. DISTRIBUTION CODE	
13. ABSTRACT ( <i>Maximum 200 words</i> )  DYE-2, a Distant Early Warning station, is located on the Greenland ice cap approximately along the Arctic Circle, 470 km from the west coast. The viscous nature of the material on which the structure is grounded made periodic monitoring and maintenance of the supporting structure necessary. This report analyzes the stresses developed within the structure from the last major maintenance operation, a 64-m sideways move in 1982 to a new foundation, to the final set of stress measurements taken at the abandoned site in 1988. Conclusions drawn from these measurements and the subsequent analysis were that the building system was continuing to tilt in one direction because of differential footing settlement caused by changing footing conditions, and high structural stresses would make it unsafe for reoccupation after December of 1988 unless emergency maintenance was performed. The U.S. Air Force officially abandoned the site in August 1988 as a result of this analysis.				
14. SUBJECT TERMS Differential settlement DYE-2			Footings Snow foundation	Structural stresses Supporting structures
			15. NUMBER OF PAGES 26	
			16. PRICE CODE	
17. SECURITY CLASSIFICATION OF REPORT UNCLASSIFIED	18. SECURITY CLASSIFICATION OF THIS PAGE UNCLASSIFIED	19. SECURITY CLASSIFICATION OF ABSTRACT UNCLASSIFIED	20. LIMITATION OF ABSTRACT UL	

**INTERNET DOCUMENT INFORMATION FORM**

**A . Report Title: Structural Analysis of DEW Line Station DYE-2  
Greenland 1983-1988**

**B. DATE Report Downloaded From the Internet: 15 Sep 98**

**C. Report's Point of Contact: (Name, Organization, Address,  
Office Symbol, & Ph #:) US Army Corps of Engineers, Cold  
Regions Research & Engineering  
Laboratory  
Hannover, NH**

**D. Currently Applicable Classification Level: Unclassified**

**E. Distribution Statement A: Approved for Public Release**

**F. The foregoing information was compiled and provided by:  
DTIC-OCA, Initials: \_\_PM\_\_ Preparation Date: 15 Sep 98**

The foregoing information should exactly correspond to the Title, Report Number, and the Date on the accompanying report document. If there are mismatches, or other questions, contact the above OCA Representative for resolution.