

# DRAFT

**Display Monitor Measurement  
Methods under discussion by  
EIA (Electronic Industries Association)  
Committee JT-20**

**Part 1: Monochrome CRT  
Monitor Performance**

**Draft  
Version 2.0  
July 12, 1995**

**Approved for public release; distribution is unlimited.**

19980922 063

**Submitted to EIA JT-20 by:**

**National Information Display Laboratory  
P.O. Box 8619  
Princeton, NJ 08543-8619  
TEL (609) 951-0150  
FAX (609) 734-2313**

*AQ 198-12-2502*

**Publication No. 171795-036**

The U.S. Government has contract rights in this report through the  
National Information Display Laboratory (NIDL)

National Information Display Laboratory  
Publication No. 171795-036

July 12, 1995

Dear Monitor Professional,

The National Information Display Laboratory would like to present for your consideration *Display Monitor Measurement Methods under discussion by EIA (Electronic Industries Association) Committee JT-20 Part 1: Monochrome CRT Monitor Performance Draft Version 2.0*. We would also like to express our gratitude to members of the SID Standards and Definitions Committee, the U.S. Government, members of the VESA, NIST, and members of the display industry who have provided many highly constructive and valuable suggestions for improving our earlier version of this document, suggestions which we have implemented in this document. We encourage you to review this document and to let us know how we can further improve it to meet your needs.

The goal of this document is to provide practical, tested procedures for obtaining and reporting consistent and repeatable performance measurements of monochrome CRT displays, especially those used in gray-scale imagery analysis. The reported results of these measurements can be used to determine whether a candidate display can meet the needs of Image Analysts and other critical users such as radiologists in the medical imaging community, thus enabling users to easily make an objective comparison when choosing between candidate displays. The goal is not to reinvent, but to identify, incorporate, and revise as appropriate, measurement standards that other standards-generating bodies have established.<sup>[1]</sup> The ultimate goal of establishing such measurement and reporting standards, and promoting their use, is to provide a common language by which display users can communicate their display needs to manufacturers, better enabling them to recognize the critical performance criteria which must be met in order to successfully provide increasingly higher quality, more cost-effective monochrome CRT displays to the user.

We believe this document presents a practical and sufficiently detailed set of measurement procedures for evaluating the performance of monochrome CRT monitors for imagery applications, and owes much to existing standards documents and to the people and organizations who created them. Existing standards documents provide established methods for evaluating monochrome CRT displays targeted for text or graphics applications. This document is intended to be complementary to existing standards by addressing the performance issues which effect whether the Image Analyst can reliably and efficiently perceive low contrast detail in monochrome images.

A standard set of measurement evaluation procedures and method of reporting the results for high-resolution displays benefits the user in many ways:

- Provides a quantifiable means to judge the performance of the display in an objective and meaningful way.

---

<sup>1</sup> Kelley, E. F., et al., *A Survey of the Components of Display-Measurement Standards*, SID 95 DIGEST, pp. 637 - 440.

- Eliminates the need for display evaluators to spend time identifying and gathering other test procedure documents generated by a variety of organizations.
- Results in information which is useful to help reduce the time required to select a display that optimally meets the critical needs of the user.
- Avoids excessive costs of purchasing overspecified displays when standardized measurements are used to provide the exact performance criteria for selecting a display.
- Promotes a common language to describe the exact requirements of the user, thus enabling the display industry to develop and maintain monitors that better meet users' needs.

Applying the previous version of NIDL measurement procedures, NIDL and NIST successfully completed the first-known round-robin set of measurements on one CRT display monitor using two very different sets of measurement equipment but working from the same set of measurement procedures. The results, identical to within small measurement errors, were presented at SID [2] where manufacturers were encouraged to conduct round-robins with NIST to confirm that their equipment or monitor data sheets provide information based on standardized measurement practices.

Again, we thank NIST, the members of the SID Standards and Definitions Committee, the U.S. Government, and members of VESA and of the display industry who have provided many highly constructive and valuable suggestions for improving our earlier version of this document. We especially want to state our appreciation to Edward Kelley, Danny Gross, Carlo Infante and Howard Okamoto for their many constructive comments and suggestions, as well. We would also like to acknowledge the dedicated efforts of NIDL retirees, Peter Wojtowicz and Arthur Miller, for their contributions to the conception and in the development of this document.

As we work towards gaining acceptance of each of these sets of test procedures as national and world standards through established channels including the SID, the EIA, ANSI, ISO and VESA organizations, we look forward to receiving your comments as soon as possible. Please send your comments either by Email to [NIDL@nidl.org](mailto:NIDL@nidl.org) or to:

Michael Grote  
National Information Display Laboratory  
P.O. Box 8619  
Princeton, NJ 08543-8619

Sincerely,

Dennis Bechis

Philip Heyman

David Bortfeld

Michael Grote

---

<sup>2</sup> Bechis, D. J., et al., *Display-Measurement Round-Robin*, SID 95 DIGEST, pp. 641 - 644.

**Tel (609) 951-0150**

**Fax (609) 734-2313**

**Email [NIDL@nidl.org](mailto:NIDL@nidl.org)**

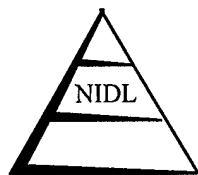

## SAMPLE EVALUATION DATASHEET

### I. MANUFACTURER'S DATA

Manufacturer Name	Company ABC
Model #	1A
Monochrome or Color	Monochrome
Screen Diagonal	21 inches
Horizontal Scan Rate	89.71 kHz
Vertical Scan Rate	72.00 Hz
Image Size (H x V)	380.0 mm x 284.5 mm (14.96 x 11.20 inches)
Addressable Pixel Number	1600 x 1200
Pixel Size	0.237 x 0.237 mm (9.35 x 9.33 mils)
Dot or Stripe Pitch	0.28mm (11.0 mils)

### II. MEASURED PERFORMANCES

#### A. Performance Related to Luminance

Warmup Time	20 minutes to $\pm 1\%$
Full Screen Luminance	103 cd/m <sup>2</sup> (30 fL)
Luminance Uniformity	76.67 - 96.13 cd/m <sup>2</sup>
Color Coordinates	x = 0.282, y = 0.295
Color Uniformity	2.9% in x, 4.1% in y
System Gamma	2.45
Luminance Stability	=12%

#### B. Performances Related to Geometry

Waviness	= 0.4%
Linearity	= 2.6%
Raster Size Stability	= 0.1%
Jitter	< 0.13 mm (< 5 mils)

#### C. Performance Related to Resolution

50% Linewidth (HxV):		
center		0.328 x 0.287 mm (12.9 x 11.3 mils)
average periphery		0.340 x 0.284 mm (13.4 x 11.2 mils)
worst location (@ 10:00)		0.399 x 0.290 mm (15.7 x 11.4 mils)
Faceplate Reflectivity	specular	20%
	diffuse	3%
Contrast Ratio		75:1
Halation		= 5.6%
1-on/1-off Contrast Modulation (HxV):		
center		43 x 31%
average periphery		16 x 38%
worst location (@ 8:00)		6 x 46%
Resolvable Pixels (HxV) (screen average)		
@ C <sub>m</sub> = 25%		1412 x 1174
@ C <sub>m</sub> = 50%		1047 x 970

**D. Reliability and Life Performance**

MTBF	10,000 h
Cathode life at 100 cd/m <sup>2</sup> luminance	10,000 h

**E. Evaluator**

Organization Name	Testing Lab XYZ
Address	Tucson, AZ
Phone	( ) - - - - -
Evaluation Dates	3/1/93 to 4/1/93
Equipment Used	Photo Research PR-704, Microvision SS100

**F. Additional Performance Measurements Available: (Y X / N   )**

## Cross-Reference to Applicable Measurement Procedure

### A. Performance Related to Luminance

Warmup Time	4.1 Warmup Characteristics, Page 21
Full Screen Luminance	3.0 Initial Monitor Setup, page 17
Luminance Uniformity	4.4 Luminance and Color Uniformity, page 28
Color Coordinates	3.0 Initial Monitor Setup, page 17
Color Uniformity	4.4 Luminance and Color Uniformity, page 28
System Gamma	4.2 System Gamma, Page 23
Luminance Stability	4.3 Luminance Stability vs. Fill Factor, page 26

### B. Performances Related to Geometry

Waviness	6.1 Waviness, page 67
Linearity	6.2 Linearity, page 73
Raster Size Stability	6.3 Raster Size Stability, page 78
Jitter	6.4 Scan Variability With Time, Page 80

### C. Performance Related to Resolution

50% Linewidth (HxV): center average periphery worst location (@ 10:00)	5.1 Linewidth, page 47
Faceplate Reflectivity    specular, diffuse	4.5 Reflectance, page 31
Contrast Ratio	4.7 Contrast Ratio, page 39
Halation	4.6 Halation, page 35
1-on/1-off Contrast Modulation (HxV): center average periphery worst location (@ 8:00)	5.2 Contrast Modulation, page 51
Resolvable Pixels (HxV) (screen average) @ $C_m = 25\%$ @ $C_m = 50\%$	5.2 Contrast Modulation, page 51

### D. Reliability and Life Performance

MTBF Cathode life at 100 cd/m <sup>2</sup> luminance	4.8 Lifetest, page 41
---	-----------------------

This page intentionally left blank.

## Preface

*Display Monitor Measurement Methods under discussion by EIA (Electronic Industries Association) Committee JT-20 Part 1: Monochrome CRT Monitor Performance Draft Version 2.0* along with companion document *Display Monitor Measurement Methods under discussion by EIA (Electronic Industries Association) Committee JT-20 Part 2: Color CRT Monitor Performance Draft Version 2.0* are intended to satisfy a need expressed by many users and evaluators of displays in the government, medical, and commercial communities, as well as by manufacturers of displays and display systems, for a self-contained, comprehensive document of evaluation procedures for characterizing the photometric and electrical response related to the performance of monochrome and color CRT display monitors. The documents enable evaluators in different laboratories to conduct standardized measurements of aspects of CRT monitor performance and to attain the same results when measuring the same display. In turn, this benefits purchasers and manufacturers of CRT monitors by providing a means of specifying and measuring display performance in a common, meaningful way. By providing standardized procedures that can be consistently repeated, the documents benefit users who need to track the performance of their displays over time and perform quality control adjustments. By being self-contained and as comprehensive as possible, the documents enable users and manufacturers to rapidly access, read, and implement tests of display systems, and eliminate the need of display evaluators to spend time identifying and gathering test procedure documents generated by a variety of organizations. The procedures are intended to be applicable to CRT monitor displays of all performance levels, covering the gamut from low resolution CGA displays to high resolution displays with greater than 2500 x 2000 pixels.

It is equally important to state what this document is not intended to achieve. Each issue mentioned below represents an important need that evaluators and specifiers of display systems have. Some of these needs are addressed by existing standards documents for particular display user tasks. Other issues stated here represent needs that call for additional scientific studies and human factors studies and the generation of a separate standards document.

1. *Display Monitor Measurement Methods under discussion by EIA (Electronic Industries Association) Committee JT-20 Part 1: Monochrome CRT Monitor Performance Draft Version 2.0* does not specify which procedures to use to evaluate the capability of a display system to enable its user to accomplish a particular task with the maximum of efficiency and reliability.
2. Furthermore, the document does not specify or recommend the values or the ranges of values which the display system must achieve in a specific test procedure or set of test procedures for the display system to "qualify" for use in a particular task.

3. The document does not address which measured performance parameters can be traded off against one another and by how much and still allow the display to achieve a level of performance that is acceptable for a particular task.
4. The document is not intended to rule out or judge alternative test procedures that may have been developed to measure the same physical effect. Such test procedures may employ different laboratory measurement equipment, different measurement procedures, and different analysis techniques. However, since the goal is to provide a common basis for comparison of monitor performance parameters, discrepancies in measured performance parameters obtained by different test procedures are unacceptable and need to be resolved.

These test procedures for evaluating the critical performance parameters including resolution, luminance uniformity, and geometric distortions have been condensed from an earlier draft of a different NIDL document *Test Procedures for Evaluation of CRT Display Monitors Version 3.1 dated 6/15/92*. Additional test procedures for measuring parameters such as spot size and video amplifier bandwidth are useful as diagnostics and will be developed for inclusion in a future document.

## CONTENTS

<b>Section 1.0</b>	<b>Introduction .....</b>	<b>1</b>
<b>Section 2.0</b>	<b>Required Equipment.....</b>	<b>3</b>
2.1	Examples of Required Equipment .....	3
2.1.1	Video Generator .....	3
2.1.2	Spatial Luminance Measurement Equipment.....	8
2.1.3	Luminance Measurement Equipment .....	10
2.1.4	Color Measurement Equipment .....	13
2.2	Equipment Calibration .....	14
2.2.1	Luminance Calibration.....	14
2.2.2	Color Calibration.....	15
2.2.3	Spatial Luminance Calibration.....	16
<b>Section 3.0</b>	<b>Initial Monitor Setup .....</b>	<b>17</b>
<b>Section 4.0</b>	<b>Photometric Characterization .....</b>	<b>21</b>
4.1	Warmup Characteristics .....	21
4.2	System Gamma.....	23
4.3	Luminance Stability vs. Fill Factor .....	26
4.4	Luminance and Color Uniformity .....	28
4.5	Reflectance .....	31
4.6	Halation.....	35
4.7	Contrast Ratio .....	39
4.8	Lifetest .....	41
4.9	Display Spatial Noise.....	44
<b>Section 5.0</b>	<b>Resolution Characterization .....</b>	<b>47</b>
5.1	Line Width.....	47
5.2	Contrast Modulation.....	51
<b>Section 6.0</b>	<b>Geometric Characterization .....</b>	<b>67</b>
6.1	Waviness .....	67
6.2	Linearity .....	73
6.3	Raster Size Stability.....	78

6.4 Scan Variability With Time: Jitter, Swim, Drift .....80

**Section 7.0 Reporting..... 83**

**References ..... 85**

**Appendix A: Definitions of Measurement Terms and Acronyms ..... A-1**

**Appendix B: Screen Test Point Locations..... B-1**

**Appendix C: Determination of Flicker Perceptibility..... C-1**

## 1.0 INTRODUCTION

To be unambiguous, a standardized test procedure for characterizing the photometric response of a CRT display monitor not only must state what needs to be done, but also describe a particular method for accomplishing the task and an example including data analysis. As stated in the Preface, alternative methods of accomplishing the same task using different equipment, different procedures, and/or different analysis techniques are acceptable if they are equivalent, that is, they yield the same measured performance parameter(s) when applied to the same CRT display.

To achieve this purpose, each procedure is structured in the following manner:

- **Objective** states not only what physical performance parameters are to be measured, but also provides a rationale for the measurement (why this is an important measurement for evaluating a CRT monitor).
- **References** states what standardized measurement procedures may already exist for this performance metric. Furthermore, References states whether the measurement procedure contained herein is identical to the standardized existing procedure or whether the existing measurement procedure has been modified or abandoned. Reasons for modifications or abandonment are provided.
- **Equipment** provides a list of necessary generic measurement devices. Specific examples of commercial measurement equipment are provided in Section 2.0 of this document, without qualification or endorsement, and without the intent of providing a complete list.
- **Procedure** describes a procedure for generating the data necessary for characterizing this particular aspect of display performance.
- **Data** provides a description of the output of fully implementing the Procedure, and in many cases, a representative sample sheet for tabulating the data is included.
- **Analysis** explains how the data is treated mathematically and presents the equations used to arrive at the final measured performance parameter or set of parameters.
- **Output** presents a sample of the Analysis results.

This document is divided into the following sections:

- **Section 2.0** lists the generic equipment required to conduct the measurements, provides examples of the required photometric and electrical equipment, provides instructions on the calibration of the photometric equipment. Section 2.0 also provides optional measurement procedures to characterize the

electrical performance of the video signal generator required in nearly all measurements of the CRT display monitor performance.

- **Section 3.0** provides a standardized procedure for setting up the monitor to be evaluated.
- **Section 4.0** provides additional procedures to characterize the photometric performance of the CRT display monitor system.
- **Section 5.0** contains procedures for performing measurements to determine the most important performance characteristic of a display monitor, its *resolution*.
- **Section 6.0** provides additional procedures to characterize the geometric performance of the CRT display monitor system.
- **Section 7.0** contains a sample of a proposed standard monitor specification sheet for reporting measurement results in a format which enables the display user to make an objective and consistent comparison between candidate monitors.

## 2.0 REQUIRED EQUIPMENT

### 2.1 Examples of Required Equipment

#### 2.1.1 Video Generator

**Function:** The video generator drives the monitor with input signals for displaying a wide variety of test patterns.

The programmable video test pattern generator used to generate the signals driving the displays must conform to the impedance and signal level requirements of EIA RS-343-A *Electrical Performance Standards for High Resolution Monochrome Closed Circuit Television Camera* with the display driven to its maximum addressability. A composite video signal level of 1.0Vp-p composed of 0.714V maximum video level plus a sync level of 0.286V is most common. Besides meeting the required scan rates and pixel frequency or dot-clock rate of the monitor under test, the video generator must also meet the required levels of programmability and signal quality appropriate for the monitor being evaluated. The video test pattern generator need not meet the video signal timing specifications of RS-343-A.

**References:** Infante, Carlo, et. al., *A 230MHz Bandwidth High-Resolution Monitor*, SID'83 Digest, pp 124-125.

RS-343-A, *Electrical Performance Standards for High Resolution Monochrome Closed Circuit Television Camera*, EIA, September 1969.

Mullins, Mark, *How to Measure Signal Jitter*, Electronic Products, July 1992, pp 41-44.

**Test patterns:** The programmable video generator should be capable of displaying the following test patterns depicted in Figures 2.1.1-1 through 2.1.1-9

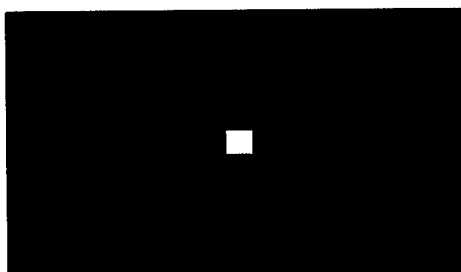

*Square box, 1% screen area in size.*

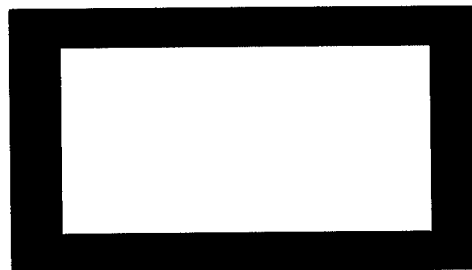

*Full flat field.*

*(Size to the nearest addressable pixel)*

**Figure 2.1.1-1**

*All addressable pixels ON*

**Figure 2.1.1-2**

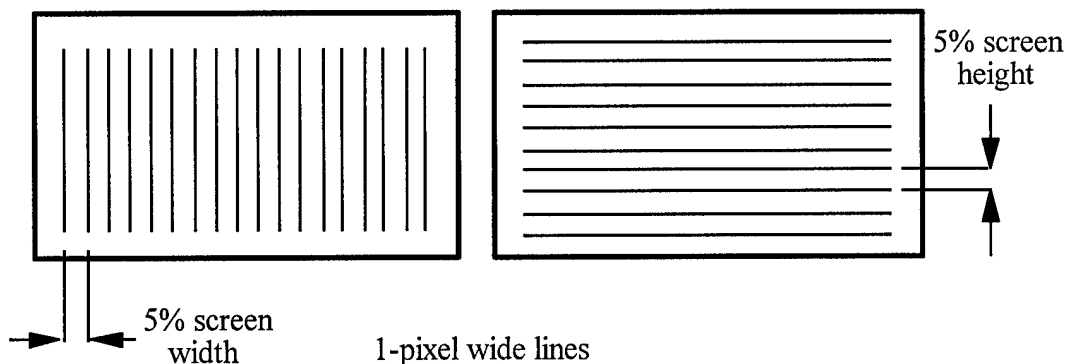

### ***Linearity Test Patterns***

*Line spacing is 5% to the nearest addressable pixel. Spacing in number of addressable pixels must be exactly equal between all vertical lines, and must be exactly equal between all horizontal lines. Use V-lines for measuring horizontal linearity and H-lines for measuring vertical linearity.*

**Figure 2.1.1-3**

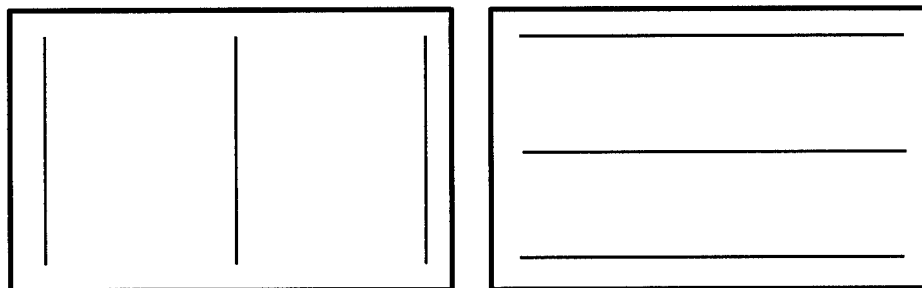

### ***Waviness Test Patterns***

*Three-line test patterns with 1-pixel-wide lines, V-lines for measuring horizontal waviness and H-lines for measuring vertical waviness*

**Figure 2.1.1-4**

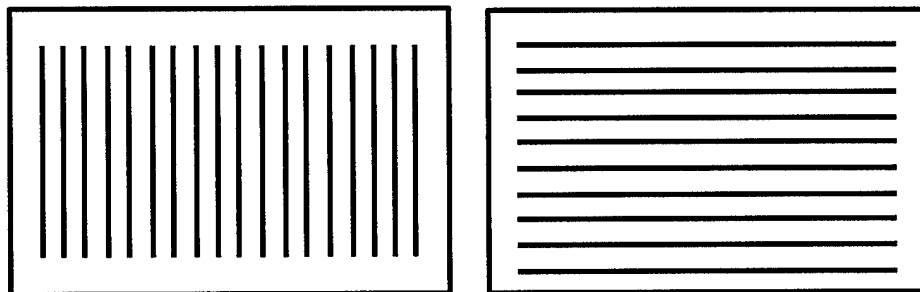

V-grille

H-grille

**Contrast Modulation Test Pattern**

Full screen level-p/level-v grille test patterns  
*n*-pixel wide lines and *n*-pixel wide spaces, for *n* = 1,2,3

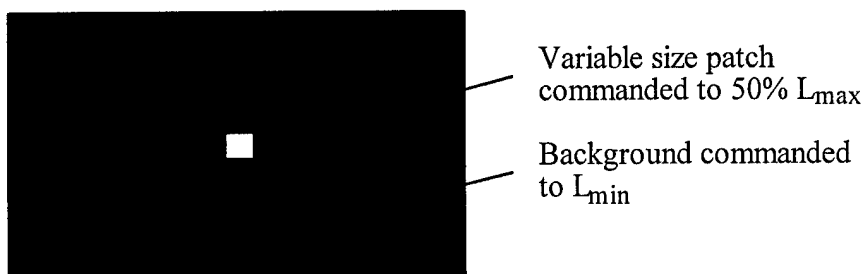
**Figure 2.1.1-5****Luminance Stability Test Pattern**

Variable size square box at 50% maximum luminance of the display ( $L_{max}$ ).  
 Background at minimum luminance of the display ( $L_{min}$ ). The target initially spans 5%  
 of the smaller dimension (either height or width) of the addressable screen. The size is  
 then increased in 10% addressable screen increments until the full screen is lit with all  
 pixels on. Size of boxes are to the nearest addressable pixel.

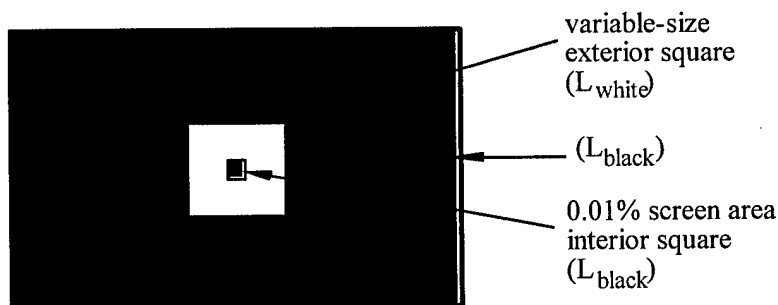
**Figure 2.1.1-6****Halation test pattern**

Interior and exterior square boxes for measuring halation.  
 Exterior square is varied in 10% increments from 5% to 100% of addressable area.  
 Size of boxes are to the nearest addressable pixel.

**Figure 2.1.1-7**

**Procedure:** Sample risetime requirements for video systems including the generator and the CRT monitor are listed in Table 2.1.1-I below. The risetime of the video chain is approximately equal to the square root of the sum of the squares of the risetimes of the individual components, that is, the video generator and the video system of the monitor. From this relationship, the video generator risetimes listed below are three times faster than that of the monitor in order not to degrade the monitor performance by more than 5%. In practice, the video generator should be 3 to 5 times faster than the monitor being tested.

Risetime required for a particular pixel rate is calculated assuming a 1/2 rule: i.e., the rise time should be 1/2 the pixel period. Optionally, the more conservative 1/3 rule which states that the risetime should be 1/3 the pixel period, may be used.

**Table 2.1.1-I:** Sample video generator requirements assuming 60Hz non-interlaced vertical scanning, 20% horizontal blanking, and 3% vertical blanking:

Pixel format (H x V)	Horizontal scan rate (KHz)	Pixel-rate (MHz)	Monitor Rise time (ns) using 1/2 rule	Generator Rise time (ns) 3 times faster
640 x 480	29.7	23.8	< 21.1	< 7.02
800 x 600	37.1	37.1	< 13.5	< 4.49
1024 x 780	48.2	61.8	< 8.10	< 2.70
1280 x 1024	63.3	101	< 4.93	< 1.64
1600 x 1280	79.2	158	< 3.16	< 1.05
2048 x 1536	95.0	243	< 2.06	< 0.68
2048 x 2048	127	324	< 1.54	< 0.51
2048 x 2560	158	405	< 1.23	< 0.41

Optionally, evaluate the signal quality of the video generator.

1. Use an oscilloscope to view a video ramp signal and measure the amplitude of spurious voltage pulses which may be generated by the digital-to-analog circuitry of the video driver.
2. Characterize distortions of the source video pattern generator by measuring rise and fall times, ripple, undershoot and overshoot in the video pulse shape. Tabulate the pulse rise and fall times from the 10% to the 90% steady state ON level. Calculate the effective bandwidth using equation (1):

$$(1) \text{ Bandwidth (MHz)} = \frac{350}{\text{Rise time (ns)}}$$

3. Measure the video jitter contribution of the source generator using a digital storage oscilloscope in envelope mode. A counter may be used to measure rms amplitudes of jitter. A time interval analyzer or a timer/counter with PC-based modulation domain analysis can be used to obtain plots of jitter frequency as a function of time.

**Examples:** Examples of programmable video test pattern generators include:

- Quantum Data Fox series
  - 8701E-1 to 400 MHz
  - 8701E-6 to 285 MHz
  - 8701E-3 to 135 MHz
- Team Systems ASTRO 800 series
  - VG-850 to 400 MHz
  - VG-819 to 240 MHz
  - VG-814 to 75 MHz
- Quantum Data 900 series
  - 903 to 250 MHz
  - 902 to 135 MHz
  - 901 to 87 MHz
- Visual Information Systems
  - VII 2800 to 150 MHz
  - VII 2701B to 125 MHz
  - VII 2700 to 80 MHz

**Accuracy:** One manufacturer specifies video signal jitter in the range of 0.1% for timing error between pixels of adjacent scan lines. Analog oscilloscopes may contribute significantly to the jitter being measured and are considered to serve as a means for obtaining the general jitter envelope. Better accuracy of the peak jitter measurement can be achieved by using a digital storage oscilloscope in envelope mode.

### 2.1.2 Spatial Luminance Measurement Equipment

**Function:** Spatial luminance (beam profile) measurements are required to evaluate linewidth, contrast modulation, waviness, linearity, jitter, and raster size. Spatial luminance measurements may be performed using any of a number of techniques described in ARP1782:

1. By slowly moving the image past a slit or round aperture of a photometer either:
  - (a) by mechanically moving the photometer past the image (scanning slit method),
  - (b) by electrically moving the image past the photometer (moving beam method), or
2. By focusing the image onto a spatially calibrated photodiode or CCD linear array.

Some measurement equipment companies provide systems that enable one to move the beam across the raster in sub-pixel increments using programmable time delay circuits to alter the relationship between vertical and horizontal synchronization pulses.

**References:** MPR 1990:8 *Test Methods for Visual Display Units*, Swedish National Board for Measurement and Testing, Dec. 1990.

TEPAC 105-7-A, *Line Profile Measurements in Monochrome Cathode Ray Tubes*, EIA, Jan. 1987.

TEPAC 105-8, *Raster Response Measurement for Monochrome Cathode Ray Tubes*, EIA, Jan. 1987.

TEPAC 105-9, *Line Profile Measurements in Shadow Mask and Other Structured Screen Cathode Ray Tubes*, EIA, Jan. 1987.

ARP1782, *Photometric and Colorimetric Measurement Procedures for Airborne Direct View CRT Displays*, SAE, Jan. 1989.

**Examples:** Examples of manufacturers of spatial luminance measurement equipment include:

- Microvision SUPERSPOT 100 CRT Measurement System
- EG&G Gamma Scientific GS-2110A
- Spectron Engineering
- Minolta
- Photo Research PR-900 CRT Measurement System
- Celco
- Quantum Data CP-1

**Accuracy:** Scanning photometer or matrix photometer, (i.e., photodiode or CCD linear array detector)  $\pm 0.1$  mm accuracy. [MPR 1990:8]

With 1% photodetector linearity, ambient lighting less than 1% peak display luminance and 10 times less than intensity level being measured (for example, reduce ambient lighting to less than 0.1% for measuring line width at the 1% intensity level of the profile), and at least 3-digit digital-to-analog conversions, then linewidth measurement accuracy of 3% to 5% is possible. [ARP1782].

Accuracy of x,y translation stage should be better than 0.1% of the linear screen size over the display screen area for raster distortion (linearity, waviness) measurements. [ARP1782]

## 2.1.3 Luminance Measurement Equipment

### 2.1.3.1 Photometer

**Function:** Required to measure average area luminance on the display for evaluating raster luminance, system gamma, luminance stability, luminance uniformity, and halation. Meter measurement angle should be  $0.3^\circ$  to  $2^\circ$  and range of 0 to  $500 \text{ cd/m}^2$  (146 fL) or higher. [MPR 1990:8] Measurement field should be maximum 1/2-target size. [ISO 9241] Use measurement field encompassing at least 10 scanning lines for raster luminance measurement. [TEPAC 105-81] Operate the detector in its linear range using neutral density filters, if necessary. Photometers should have a uniform responsivity of the measured surface. Veiling glare (surrounding luminance) should not effect the results of the measurement. [CIE Publication 69]

**References:** MPR 1990:8 *Test Methods for Visual Display Units*, Swedish National Board for Measurement and Testing, Dec. 1990.

ISO 9241 Part 3: *Visual Displays, Visual Display Terminals (VDTs) Used for Office Tasks - Ergonomic Requirements - Part 3: Visual Displays Final Text* as of June 1992.

TEPAC 105-81, *Industrial Cathode Ray Tube Test Methods*, EIA, Feb. 1981.

Miller, Ken, *Matching photometers to applications*, Information Display, 9/89, pp 7-9,18.

ARP1782, *Photometric and Colorimetric Measurement Procedures for Airborne Direct View CRT Displays*, SAE, Jan. 1989.

**Examples:** Examples of photometers include:

- Photo Research Pritchard 1980B
- United Detector Technologies S370 Optometer
- Photo Research PR-704 Spectra-Radiometer
- Minolta CA100
- Tektronix
- EG&G Gamma Scientific

**Accuracy:**  $\pm 10\%$  accuracy for absolute luminance measurement. [MPR 1990:8] Expect photometer accuracy to be at least  $\pm 5\%$ . Luminance measured using a calibrated colorimeter should be accurate to within  $\pm 5\%$  and repeatable to within  $\pm 2\%$ . Use a measurement field covering at least 10 scanning lines for raster luminance measurement. [TEPAC Publ.105] The

photodetector sensitivity should be made linear to within  $\pm 1\%$  over the measurement range. [ARP1782]

### 2.1.3.2 Micro-Photometer

**Function:** The micro-photometer is required for measuring linewidth (beam profile) and luminance of peaks and valleys of grille patterns used for evaluating display contrast modulation. Measure peak luminance over a measurement field of less than 1/10-pixel. [TEPAC 105-7-A] (ISO 9241 specifies measurement field of micro-photometer to be a maximum 1/8-pixel width.) Operate the detector in its linear range using neutral density filters, if necessary.

**References:** MPR 1990:8 *Test Methods for Visual Display Units*, Swedish National Board for Measurement and Testing, Dec. 1990.

ISO 9241 Part 3: Visual Displays, *Visual Display Terminals (VDTs) Used for Office Tasks - Ergonomic Requirements - Part 3: Visual Displays Final Text* as of June 1992.

TEPAC 105-81, *Industrial Cathode Ray Tube Test Methods*, EIA, Feb. 1981.

TEPAC Publ.105-7-A, *Line Profile Measurements in Monochrome Cathode Ray Tubes*, EIA, Jan. 1987.

TEPAC Publ.105-8, *Raster Response Measurement for Monochrome Cathode Ray Tubes*, EIA, Jan. 1987.

**Examples:** Examples of manufacturers of micro-photometers include:

- Photo Research
- EG&G Gamma Scientific
- Microvision
- Minolta
- Quantum Data

**Accuracy :**  $\pm 10\%$  accuracy for luminance measurement in 380 to 780 nm wavelength range. [MPR 1990:8]

### 2.1.3.3 Luminance standards

**Function:** Provide a standard luminance source traceable to NIST for calibrating photometer and spectroradiometer. Standard light source should be nonpolarized. Standard luminance source should be capable of producing four (4) luminance standard settings: 25%, 50%, 75%, and 100%  $L_{\max}$  of the monitor under test.

**References:** CIE Publication 69, *Methods of Characterizing Illuminance Meters and Luminance Meters*, CIE, 1987.

**Examples:** Luminance standard lamps can be obtained from:

- National Institute of Standards and Technology (NIST), formerly National Bureau of Standards (NBS) traceable standard lamp
- Hoffman Laboratories
- LMT
- Labsphere
- EG&G Gamma Scientific
- Photo Research

**Accuracy:** Calibration errors are mainly caused by incorrect setting of electrical parameters of the light source, ageing of the photometric standard, or stray light. Luminance uniformity across the light surface should be better than 2% within 15° of surface normal. [CIE Publication 69] Expect accuracy of luminance standard to be better than 4%.

### 2.1.4 Color Measurement Equipment

**Function:** For monochrome displays, chromaticity coordinates are measured to evaluate, color spatial uniformity, and variation of chromaticity as a function of luminance. Color measurement equipment may include preferably a spectroradiometer or colorimeter for measuring chromaticity coordinates or color temperature of the display. Use a spectroradiometer with minimum 400 to 700 nm wavelength range. If a colorimeter is used, it should be calibrated to a spectroradiometer.

**References:** ASTM E1336 - 91, *Standard Test Method for Obtaining Colorimetric Data from a Video Display Unit by Spectroradiometry*.

CIE 63, *The Spectroradiometric Measurement of Light Sources*, 1984.

MPR 1990:8 *Test Methods for Visual Display Units*, Swedish National Board for Measurement and Testing, Dec. 1990.

TEP105-11-A, *Measurement of the Color of CRT Screens*, EIA, Dec. 1988.

**Examples:** Examples of spectroradiometers include:

- Photo Research PR704 Spectra-Radiometer
- Photo Research PR900 Spectra-Radiometer
- EG&G Gamma Scientific

Examples of colorimeters include:

- Minolta CA100
- Tektronix J17

**Accuracy:** MPR 1990:8 specifies  $\pm 5$ nm wavelength accuracy in the 300 to 800 nm range, and  $\pm 10\%$  accuracy for the color measurement.

TEP105-11-A specifies a spectroradiometer wavelength range from 400nm to 700nm range (380 to 720 nm range preferred) with  $\pm 1$ nm wavelength accuracy when measuring a standard lamp. Color x and y CIE coordinates should be accurate within  $\pm 0.003$  units and repeatable within  $\pm 0.0005$  units. Accuracy of a colorimeter should be  $\pm 0.006$  CIE x and y coordinates and repeatable within  $\pm 0.001$ .

## 2.2 Equipment Calibration

### 2.2.1 Luminance Calibration

**Objective:** Calibrate luminance measurement equipment using a NIST (NBS) traceable luminance standard or calibrated photometer as a reference.

**References:** CIE Publication 69, *Methods of Characterizing Illuminance Meters and Luminance Meters*, CIE, 1987.

ARP1782, *Photometric and Colorimetric Measurement Procedures for Airborne Direct View CRT Displays*, SAE, Jan. 1989.

**Equipment:**

- Photometer
- NIST (NBS) traceable luminance standard lamp

**Procedure:** *Luminance calibration:* Calibrate against a standard luminance source at four (4) luminance standard settings: 25%, 50%, 75%, and 100%  $L_{\text{max}}$  of the monitor under test.

Photometer can be calibrated using a commercially available standard light source. Use neutral density filters or a variable standard light source to measure light-transfer characteristics at the four (4) luminances listed above. If light-transfer characteristics have been determined, then detector nonlinearity can be compensated.

The photometer may also be calibrated to another calibrated photometer, colorimeter, or spectroradiometer provided the luminance source used for the calibration has the same spectral distribution as the display under test. Preferably, for the calibration use the display under test as the luminance source.

Exercise care to avoid errors caused by stray light. Focusing photometers should be precisely focused on the light source to avoid errors caused by changes in output signal due to changes in object distance. Surrounding luminance (veiling glare) should not effect the measurement. Error caused by detector fatigue can be reduced by covering the detector in darkness between measurements. Errors caused by detector ageing can be reduced by calibrating more frequently. Temperature effects can be reduced by using calibrating the detector at the same temperature at which the measurements will be made. [CIE Publication 69]

Luminance calibration should be performed regularly according to the manufacturers recommendations, at least every six months.

**Accuracy:** Measured luminance of NIST (NBS) traceable standard should be  $\pm 2\%$  of certified value. Measurement field of photometer shall be capable of being aligned to within  $\pm 5\%$  of area being measured. The photodetector should be linear within  $\pm 1\%$  over the intended luminance range. [ARP1782]

### 2.2.2 Color Calibration

**Objective:** Calibrate color measurement equipment using a luminance standard as a reference.

**References:** CIE Publication 69, *Methods of Characterizing Illuminance Meters and Luminance Meters*, CIE, 1987.

**Equipment:**

- Spectroradiometer or colorimeter
- NIST (NBS) traceable luminance standard lamp

**Procedure:** *Color calibration:* Calibrate spectroradiometer against a standard luminance source at four (4) luminance standard settings: 25%, 50%, 75%, and 100%  $L_{\max}$  of the monitor under test.

If a colorimeter is used, calibrate the colorimeter against a spectroradiometer for the CRT being measured.

Color calibration should be performed at least every six months.

**Accuracy:** TBD

### 2.2.3 Spatial Luminance Calibration

**Objective:** Calibrate spatial luminance measurement equipment using a Ronchi grating as a reference. For the particular optical setup of a CCD or photodiode array, establish the effective size of a single module element in the object plane.

**References:** ARP1782, *Photometric and Colorimetric Measurement Procedures for Airborne Direct View CRT Displays*, SAE, Jan. 1989.

**Equipment:** CCD or photodiode array optic module, or scanning photometer with x,y positioner

**Procedure:** *Spatial calibration:*

Focusing photometers should be precisely focused on the light source to avoid errors caused by optics due to changes in object distance. Assure that all optical elements, e.g., filters are in place for the calibration.

- (1) For a given lens/filter set of the optic module, adjust the distance between the grating and the module until the image of the grating is precisely focused on the CCD or photodiode array.
- (2) With optic module, view standard Ronchi grating consisting of, for example, 0.25 mm wide stripes, 0.50 mm period.
- (3) Calibrate the effective size of a single element of optic module.
- (4) The calibrated effective element size is correct provided the same procedure for adjusting the distance between the object and the optic module is used. Therefore, when making spatial luminance measurements, precisely set the distance between the module and the image being measured to achieve a focused image on the CCD or photodiode array.

**Output:** See sample Figures 2.2.3-1 and 2.2.3-2 below:

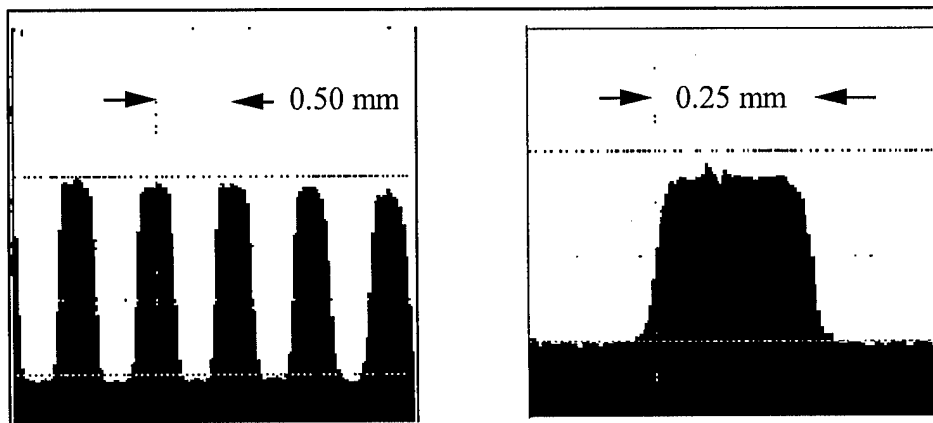

*Sample display of Ronchi ruling  
used for spatial calibration  
of diode or CCD optics.*

**Figure 2.2.3-1**

*Sample display of magnified Ronchi  
for spatial calibration of  
diode or CCD optics.*

**Figure 2.2.3-2**

### 3.0 INITIAL MONITOR SETUP

**Objective:** BRIGHTNESS, CONTRAST, and FOCUS controls are adjusted following the recommendations of the monitor manufacturer. Image size is adjusted as specified for the display format (1600 x 1200, 1280 x 1024, others).

**References:** Gray, J. E., et al., *Acceptance and Use of the SMPTE Medical Diagnostic Imaging Test Pattern for Television Monitors and Hard-Copy recording Cameras*, SMPTE Journal, December 1990, pp. 1001-1007.

SMPTE RP 133-1986, *Specifications for Medical Diagnostic Imaging Test Pattern for Television Monitors and Hard-Copy Recording Cameras*, SMPTE, Jan. 1986.

Briggs, S. J., *Soft Copy Display of Electro- Optical Imagery*, SPIE Vol. 762 Electro-Optical Imaging Systems Integration (1987), pp 153-170.

Kane Jr., J. J., *Instrumentation for Monitor Calibration*, SMPTE Journal, Sept. 1990, pp. 744 - 752.

*VESA Standard: Display Specifications and Test Procedures Version 1.0, Rev. 1.0*, 3 October 1994.

- Equipment:**
- Video pattern generator
  - Photometer
  - Photodiode or CCD array optics
  - Gaussmeter

**Test Pattern:**

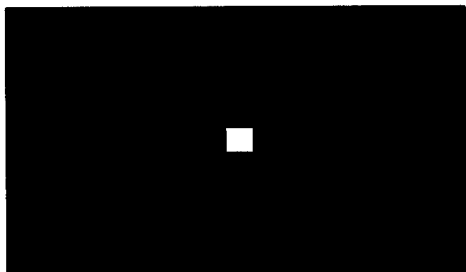

*Square box, 1% screen area  
Use this pattern to initially set  
BRIGHTNESS and CONTRAST  
controls for  $L_{min}$  and  $L_{max}$ .*

**Figure 3.0-1**

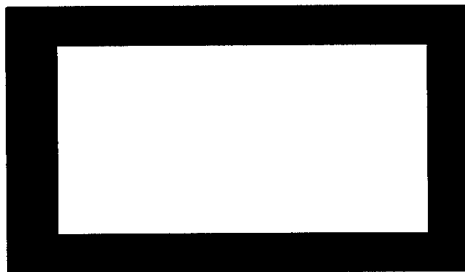

*Full flat field  
Use this pattern to adjust image size  
and to check  
effects of beam current limiting.*

**Figure 3.0-2**



**Procedure:** Note: The measurements presented in Section 4.6 Halation require changing the setting of the BRIGHTNESS control and will perturb the values of  $L_{\max}$  and  $L_{\min}$  that are established during the initial monitor set-up. The halation measurements should therefore be made either first, before the monitor setup, or last, after all other photometric measurements have been completed.

#### ***Ambient conditions***

Provisions should be made to exclude ambient light for all photometric measurements specified in this document. The light levels should be low enough that the measured luminance of the screen due to reflected ambient light, with the monitor turned off, should be less than  $0.01 \text{ cd/m}^2$  ( $0.003 \text{ fL}$ ), the value of  $L_{\min}$  specified below.

It is suggested that the horizontal and vertical components of the ambient magnetic field be measured, e.g., with a gaussmeter, at the site where the display is to be operated or tested. It should be noted that values that are in excess of typical values of the geomagnetic field (up to  $0.40 \text{ Oe}$  horizontal,  $0.70 \text{ Oe}$  vertical) may result in large spurious distortions of the raster shape.

#### ***Degauss***

Some monitors are equipped with manually activated degauss devices which should be used per manufacturer's specifications.

#### ***Warmup***

The display shall be turned on 2 hours prior to making measurements.

#### ***Size***

With the screen displaying a full flat field at the maximum input count level (255 for 8-bit systems, 1023 for 10-bit systems, 4095 for 12-bit systems) adjust the VERTICAL and HORIZONTAL size controls to obtain the specified image size and aspect ratio. Image size directly effects luminance and significantly effects resolution.

#### ***Brightness and Contrast***

The BRIGHTNESS and CONTRAST controls are used set the dynamic range of the monitor under test to  $L_{\min} = 0.01 \text{ cd/m}^2$  ( $0.003 \text{ fL}$ ) and  $L_{\max}$  as specified by the manufacturer.

With the video input voltage level set to black (zero count level) the BRIGHTNESS control is set to give a background raster equal to  $L_{\min}$  with a test target which is specified by the manufacturer. If no such target is specified by the manufacturer, one may use a rectangular patch as shown in Figure 3.0-1 equal in size to 10% of the addressable screen, and set to

count 0 at center screen. Using the same test target displayed at the maximum input count level vary the CONTRAST control to set  $L_{\max}$ .

Some monitors are equipped with *average beam current limiting* circuitry. Perform a preliminary measurement of input counts to luminance output as described in Section 4.2 System Gamma using the full flat field test pattern depicted in Figure 3.0-2. Beam current limiting is most likely to be a problem for high fill factor test patterns such as a full flat field. If luminance does not continue to rise with increases in input counts, then the beam current may be limited and a lower setup value for  $L_{\max}$  may be appropriate to ensure the intended gray scale performance.

### ***Focus***

Follow manufacturer's suggested procedure for adjusting FOCUS.

Otherwise, the FOCUS control is adjusted using a crosshatch and dot pattern with the video input level set for displaying 50%  $L_{\max}$ .

Concentrating on a dot at center screen, the FOCUS control is adjusted to give a minimum round spot as judged by eye. Further refinements in the FOCUS setting are then made by measuring the widths of horizontal and vertical lines at center screen. Linewidths are measured using CCD or photodiode optics after small incremental steps in FOCUS settings are made. Best focus is deemed to be the setting which yields the least difference between horizontal and vertical lines. The roundness of the spot is then verified by measuring the spot shape of the center screen spot. Round spots are not appropriate for all displays. In general, focus in such displays should be adjusted to achieve minimum spot width. After FOCUS has been adjusted, all subsequent measurements of the monitor should be made without further manipulation of the FOCUS control.

### ***Input voltage levels***

Determine the input count levels that correspond to the percentages of  $L_{\max}$  listed in Table 3.0-I as measured at center screen using 1% screen area square box test target shown in Figure 3.0-1. This information can be obtained from the results of the gamma measurement outlined in Section 4.2 System Gamma. The photometer measurement field should be no more than 1/2 target size, and precautions should be taken so as not to saturate the photodetector. Such precautions may include using neutral density filters to reduce luminance by a known amount to validate luminance measurements performed without filtering.

### **Data:**

Tabulate input counts to measured luminance data for convenient future reference (see sample Table 3.0-I). This data establishes the relationship between video input voltage (input count level) to specific luminance levels for all test patterns used for testing the display, and will be referred to in many of the measurement procedures that are described.



**Table 3.0-I.** Sample Data Sheet for Recording Input Counts for Specified Test Luminance Levels on an 8-Bit Display

Specified Test Luminance	Input Count Level	Specified Test Luminance	Input Count Level
$L_{min}$	0	55% $L_{max}$	_____
5% $L_{max}$	_____	70% $L_{max}$	_____
10% $L_{max}$	_____	75% $L_{max}$	_____
15% $L_{max}$	_____	80% $L_{max}$	_____
20% $L_{max}$	_____	85% $L_{max}$	_____
25% $L_{max}$	_____	90% $L_{max}$	_____
30% $L_{max}$	_____	95% $L_{max}$	_____
45% $L_{max}$	_____	100% $L_{max}$	255
50% $L_{max}$	_____		

Driving the display to one of these specific luminance levels implies setting the input count level to that level

which produced the specified luminance measured in this initial monitor setup.

**Output:** Report the full screen luminance and CIE x,y chromaticity coordinates of the display.

Full Screen Luminance	103 $cd/m^2$ (30 fL)
Color Coordinates at $L_{max}$	x = 0.282, y = 0.295

## 4.0 PHOTOMETRIC CHARACTERIZATION

### 4.1 Warmup Characteristics

**Objective:** Determine the transient photometric characteristics of the display device. Find the minimum time required for the display to stabilize to a predetermined luminance level.

**References:** None

**Equipment:**

- Photometer
- Video generator

**Test Pattern:** Flat field pattern as shown in Figure 4.1-1.

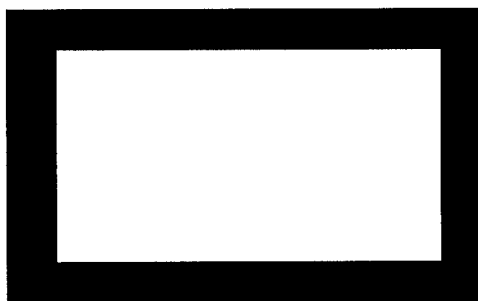

*Full Screen Flat field test pattern.*

**Figure 4.1-1**

**Procedure:** Configure the display device as described in the initial monitor setup. Power off the display, and leave it off for at least 2 hours.

Switch on the device from a cold start with video signal input set to display a full flat field, all pixels ON, at the highest input count which corresponds to  $L_{\max}$  for the display. Measure the luminance at center screen every minute during the first thirty minutes until the display has stabilized, then at longer intervals when changes occur more gradually. For example, the measurement interval should be every 1 minute for the first 30 minutes, then every 5 minutes up to the first hour, and then every 10 minutes after the first hour.

The procedures described above should be carried out in a darkened environment such that the stray luminance  $L_{\text{ambient}}$  diffusely reflected by the screen in the absence of electron-beam excitation is less than  $0.01 \text{ cd/m}^2$  (3mfL). In any case, the value of  $L_{\text{ambient}}$  should be measured and recorded.

Tabulate  $L_{\max}$  at a cold start and as the display stabilizes for at least 2 hours. A sample data sheet is given in Table 4.1-I.

**Sample Data:****TABLE 4.1-I.** Sample Warmup CharacteristicsLuminance (in  $\text{cd}/\text{m}^2$ ) as a function of time (in minutes) from a cold start.

<u>Time</u>	<u>Luminance</u>	<u>Time</u>	<u>Luminance</u>	<u>Time</u>	<u>Luminance</u>
1	105.96	15	101.88	60	100.62
2	103.53	20	101.34	70	100.62
3	103.67	25	101.16	80	100.75
4	103.01	30	101.10	90	100.45
5	103.36	40	100.65	110	100.55
10	102.33	50	100.51	120	100.75

**Analysis:** Plot the temporal variation of luminance and determine the time required to achieve luminance stability to within  $\pm 1\%$  of the maximum measured luminance.

**Output:** Report the warmup time required for the display luminance to stabilize.

Warmup Time	20 minutes to $\pm 1\%$
-------------	-------------------------

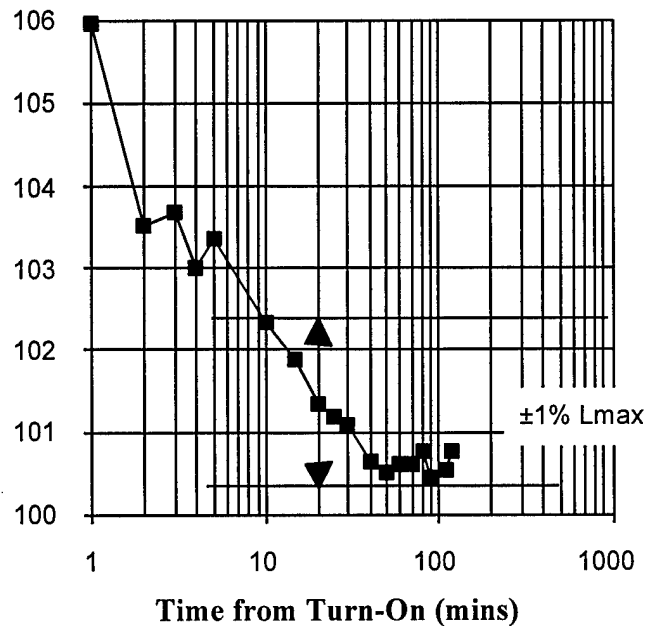

Plot of luminance as a function of time showing warmup characteristic.

**Figure 4.1-2**

**Accuracy:** Repeatability error of luminance measurement should be less than 0.1%. Absolute luminance measurement accuracy is  $\pm 10\%$ . [MPR 1990:8] Photometer accuracy is at least  $\pm 5\%$ . Use a measurement field covering at

least 10 scanning lines for raster luminance measurement. [TEPAC Publ.105] Warmup measurement results obtained by different laboratories agree to within 14%. Uncertainty of the warmup measurement is 24%.

## 4.2 System Gamma

**Objective:** Measure the nonlinear photometric characteristic (output luminance versus input drive) of the display as it spans  $L_{\min}$  to  $L_{\max}$ . Tonal variations such as intensity and shades of gray are essential for imagery tasks. Typical values for gamma range between 1.5 to 3. The gamma value determines the resolution required for the digital to analog converter and look-up table for digital to luminance mapping.

**References:** CIE No. 69, *Methods of Characterizing Illuminance Meters and Luminance Meters*, Publication, 1987.

TEPAC 105-81, *Industrial Cathode Ray Tube Test Methods*, EIA, Feb. 1981.

MPR 1990:8 *Test Methods for Visual Display Units*, Swedish National Board for Measurement and Testing, Dec. 1990.

ISO 9241 Part 3: Visual Displays, "Visual Display Terminals (VDTs) Used for Office Tasks - Ergonomic Requirements - Part 3: Visual Displays Final Text" as of June 1992.

Vandenberghe, P., et. al., *The Influence of CRT-Gamma on Luminance and Modulation*, SID 90 DIGEST, pp 152 - 155.

VESA Standard: *Display Specifications and Test Procedures Version 1.0, Rev. 1.0*, 3 October 1994.

Olson, Thor, *Behind Gamma's Disguise*, SMPTE Journal, July 1995, pp 452 - 458.

**Equipment:**

- Photometer
- Video signal generator

**Test Pattern:** Square box, 1% screen area in size as shown in Figure 4.2-1.

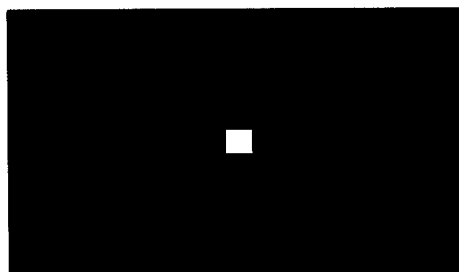

*Square box, 1% screen area in size*  
**Figure 4.2-1**

**Procedure:** Measure luminance according to CIE Publication 69. Photometer can be calibrated using a commercially available standard light source. Exercise care to avoid errors caused by stray light. Surrounding luminance (veiling glare) should not effect the measurement. Focusing photometers should be precisely focused on the light source to avoid errors caused by changes in output signal due to changes in object distance. If the light-transfer characteristics have been determined, then detector nonlinearity can be compensated. Operate the detector in its linear range using neutral density filters, if necessary. Error caused by detector fatigue can be reduced by covering the detector in darkness between measurements. Errors caused by detector ageing can be reduced by calibrating more frequently. Temperature effects can be reduced by using calibrating the detector at the same temperature at which the measurements will be made. [CIE Publication 69]

Meter measurement angle should be  $0.3^\circ$  to  $2^\circ$  and range of 0 to 500  $\text{cd/m}^2$  (146 fL) or higher. [MPR 1990:8] Use measurement field encompassing at least 10 scanning lines for raster luminance measurement. [TEPAC 105-81]

Luminance of a square box, 1% screen area in size, displayed at center screen is measured for a large number of different input counts starting with the lowest level to minimize detector fatigue effects. Display test targets ranging from video input digital count levels of 0 to the maximum input level (255 for 8-bit displays, 1023 for 10-bits, 4095 for 12-bits) For 8-bit displays, use 33 different input levels in increments of 8 counts. The corresponding average luminance is measured at center screen using a photometer with measurement field of at least 10 scanning lines in diameter.

The procedures described above should be carried out in a darkened environment such that the stray luminance  $L_{\text{ambient}}$  diffusely reflected by the screen in the absence of electron-beam excitation is less than  $0.003 \text{ cd/m}^2$  (1mfL). In any case, the value of  $L_{\text{ambient}}$  should be measured and recorded.

**Data:** Tabulate the input count to luminance transfer characteristic for the above test target.

**TABLE 4.2-I. Sample System Gamma**

Luminance at center screen as a function of input counts.

Input level (counts)	Luminance ( $\text{cd/m}^2$ )	Input level (counts)	Luminance ( $\text{cd/m}^2$ )
255	44.5	111	6.5
231	35.6	87	3.7
207	27.8	63	1.7
183	21.1	39	0.5

159	15.1	20	0.09
135	10.2		

**Analysis:** Prepare a log-log graph of the data. *System gamma* refers to the response of the CRT and the monitor electronics, including the video amplifier. The system gamma is the slope of the curve in the log-log plot. Since this curve is non-linear there does not exist a single value of gamma. Compute the best fit system gamma for the range of luminance for the intended use. Strictly speaking, gamma is a function of input drive voltage. Computation of system gamma using input counts may differ due to nonlinearities in the digital to analog circuitry.

**Output:** Report the system gamma and plot luminance as a function of input level as shown in Figure 4.2-2 below.

System Gamma	2.45 (20 to 255 counts).
--------------	--------------------------

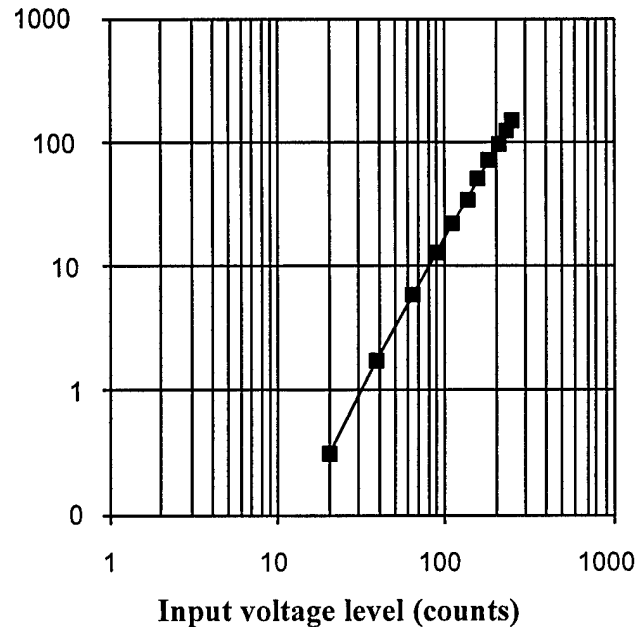

*Log-log plot of luminance as a function of input counts showing system gamma.*

**Figure 4.2-2**

**Accuracy:** Repeatability error of luminance measurement should be less than 0.1%. Absolute luminance measurement accuracy is  $\pm 10\%$ . [MPR 1990:8] Photometer accuracy is at least  $\pm 5\%$ . Use a measurement field covering at least 10 scanning lines for raster luminance measurement. [TEPAC Publ.105] System gamma measurement results obtained by different laboratories agree to within 3%. Uncertainty of the system gamma measurement is 3%.

### 4.3 Luminance Stability vs. Fill Factor

**Objective:** The purpose of this test procedure is to determine the luminance stability of the display as a function of the fill factor. Halation, phosphor saturation, video amplifier low frequency characteristics, and thermal effects may contribute to luminance instability.

**References:** None

**Equipment:**

- Photometer
- Video signal generator

**Test pattern:** Variable size square box displayed at 50%  $L_{\max}$  as shown in Figure 4.3-1.

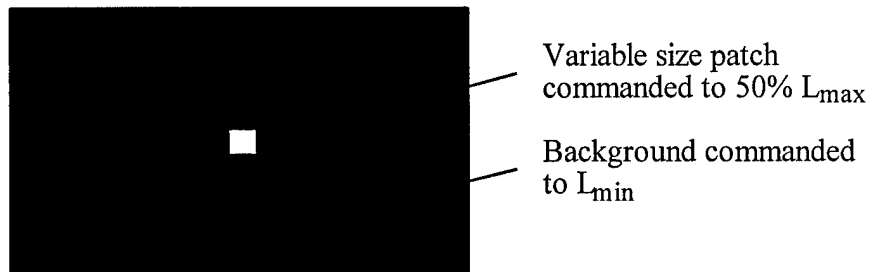

*Square box, variable sizes,  
5%, 10%, 20%, 30% . . . up to full linear dimension of screen.*

**Figure 4.3-1**

**Procedure:** The test targets used in this procedure are square white patches of various sizes at 50%  $L_{\max}$  at screen center on a background at  $L_{\min}$ . The target initially spans 5% of the lesser dimension (either height or width) of the addressable screen. The size is then increased in 10% addressable linear screen size increments until the full screen is lit with all pixels on. For all target sizes, the video input count level corresponds to 50%  $L_{\max}$  as determined in section 3.0.

The procedures described above should be carried out in a darkened environment such that the stray luminance  $L_{\text{ambient}}$  diffusely reflected by the screen in the absence of electron-beam excitation is less than 0.003  $\text{cd/m}^2$  (1mfl). In any case, the value of  $L_{\text{ambient}}$  should be measured and recorded.

**Sample Data:****TABLE 4.3-I.** Sample Data for Luminance Stability vs Fill Factor

*Luminance measured at center screen for different size square white patches on a black background. Screen luminance set at 50% Lmax.*

Luminance (cd/m <sup>2</sup> )		Luminance (cd/m <sup>2</sup> )	
% Fill Factor	@ 50% Lmax	% Fill Factor	@ 50% Lmax
5	74.00	55	79.62
15	77.56	65	80.34
25	78.01	75	82.29
35	78.25	85	82.05
45	78.73	100	82.67

**Analysis:** Plot the measured luminance as a function of target size, and compute the mean and variance. The monitor's fill factor is directly related to the target size.

**Output:** Report the maximum change in screen luminance as a percentage of the 5% fill factor luminance.

Luminance Stability	=12%
---------------------	------

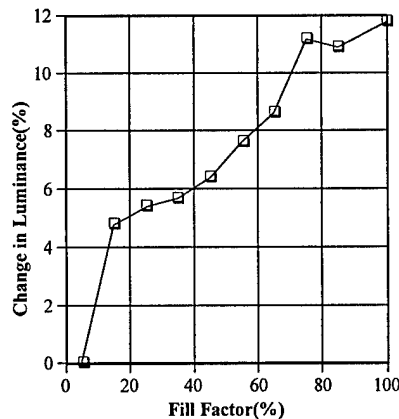

*The change in luminance with increasing screen fill factor expressed as a percentage change from the 5% fill factor luminance level.*

**Figure 4.3-2**

**Accuracy:** Luminance measurement accuracy is  $\pm 10\%$ . [MPR 1990:8] Photometer accuracy is at least  $\pm 5\%$ . Use a measurement field covering at least 10 scanning lines for raster luminance measurement. [TEPAC Publ.105]

Luminance stability measurement results obtained by different laboratories agree to within 1%. Uncertainty of the luminance stability measurement is 4%.

#### 4.4 Luminance and Color uniformity

**Objective:** Measure the variability of luminance and chromaticity coordinates of the white point as a function of intensity and as a function of spatial position. Variability of luminance impacts the total number of discriminable gray steps. Monochrome CRTs may exhibit shifts in color caused by spatial variations in the characteristics of the multicomponent white phosphors. Individual phosphor components may saturate or exhibit a change in persistence as a function of beam intensity.

**References:** ASTM E1336 - 91, *Standard Test Method for Obtaining Colorimetric Data from a Video Display Unit by Spectroradiometry*.

TEP105-11-A, *Measurement of the Color of CRT Screens*, EIA, 1988.

TEP116-B, *Optical Characteristics of CRTs*, EIA, 1989.

ISO/TC159/SC4 N201 *Ergonomics requirements for office work with visual display terminals (VDTs). Part 8 Requirements for displayed colours*, Dec. 1990.

CIE 38 *Radiometric and Photometric Characteristics of Materials and Their Measurement*, 1977.

CIE No. 69, *Methods of Characterizing Illuminance Meters and Luminance Meters*, Publication, 1987.

Tchen, H., et al., *Photocolorimetric Measurements of TV and HDTV Display Devices*, Application Notes, SID'92, pp. 75-78.

*VESA Standard: Display Specifications and Test Procedures Version 1.0, Rev. 1.0*, 3 October 1994.

**Equipment:**

- Video generator
- Photometer
- Spectroradiometer or Colorimeter

**Test Pattern:** Full screen flat field with visible edges at  $L_{\min}$  as shown in Figure 4.4-1.

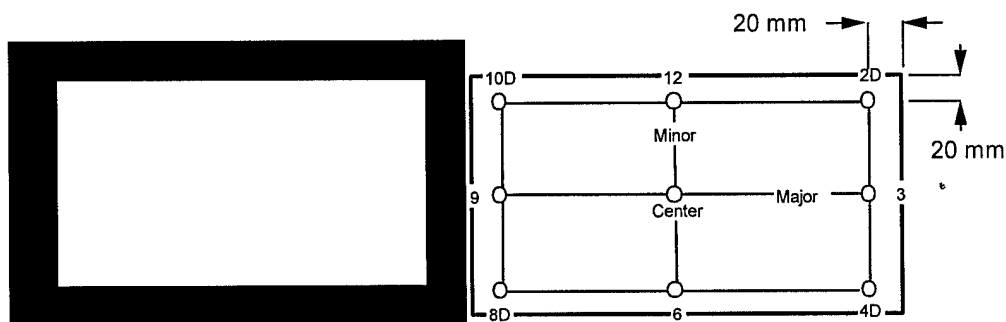

*Full Screen Flat Field test pattern.*  
**Figure 4.4-1**

*Nine screen test locations.*  
**Figure 4.4-2**

**Procedure:** Investigate the temporal variation of luminance and the white point as a function of intensity by displaying a full flat field shown in Figure 4.4-1 for four different video input count levels corresponding to 25%, 50%, 75%, and 100% of  $L_{\max}$  as determined in Section 3.0. For each input count level, measure the luminance and C.I.E. color coordinates at center screen.

Investigate the temporal variation of luminance and the white point as a function of spatial position by repeating these measurements at each of the locations depicted in Figure 4.4-2. The locations of corner screen test points are arbitrarily defined to be severe enough to adequately evaluate the capabilities of CRTs used to display high pixel-density imagery. In addition, measure variations at any other critical point as deemed by the experimenter.

The procedures described above should be carried out in a darkened environment such that the stray luminance  $L_{\text{ambient}}$  diffusely reflected by the screen in the absence of electron-beam excitation is less than  $0.003 \text{ cd/m}^2$  (1mfL). In any case, the value of  $L_{\text{ambient}}$  should be measured and recorded.

**Data:** Tabulate the luminance and 1931 C.I.E. chromaticity coordinates ( $x$ ,  $y$ ) or correlated color temperature of the white point for each intensity level at each of the nine locations depicted in Figure 4.4-2. Additionally, note the location of any additional points that are measured along with the corresponding luminance values.

## Sample Data:

**TABLE 4.4-I.** Sample Data for Spatial Uniformity of Luminance and Chromaticity Coordinates for Four Luminance Settings taken at Nine Screen Positions (in % of  $L_{max}$ )

POSITION	<u>100% Lmax</u>			<u>75% Lmax</u>		
	$\bar{x}$	$\bar{y}$	cd/m <sup>2</sup>	$\bar{x}$	$\bar{y}$	cd/m <sup>2</sup>
center	0.282	0.295	96.13	0.282	0.296	72.83
2	0.285	0.304	78.55	0.285	0.305	60.71
3	0.285	0.301	83.14	0.286	0.303	63.65
4	0.287	0.304	80.54	0.287	0.305	62.49
6	0.285	0.301	81.19	0.285	0.302	63.10
8	0.280	0.292	76.67	0.281	0.294	59.16
9	0.279	0.293	88.83	0.279	0.295	66.74
10	0.280	0.292	77.63	0.279	0.292	58.92
12	0.281	0.298	89.07	0.281	0.298	68.24

POSITION	<u>50% Lmax</u>			<u>25% Lmax</u>		
	$\bar{x}$	$\bar{y}$	cd/m <sup>2</sup>	$\bar{x}$	$\bar{y}$	cd/m <sup>2</sup>
center	0.283	0.296	48.37	0.284	0.296	24.29
2	0.285	0.307	40.63	0.287	0.309	20.45
3	0.286	0.303	42.07	0.289	0.305	20.97
4	0.289	0.307	42.17	0.292	0.311	21.62
6	0.286	0.302	42.07	0.287	0.304	21.24
8	0.281	0.295	40.56	0.283	0.296	21.34
9	0.279	0.294	44.64	0.279	0.294	22.30
10	0.278	0.292	39.88	0.279	0.291	20.73
12	0.281	0.298	45.36	0.281	0.298	22.88

**Analysis:** Compute luminance and color variation over the screen relative to screen center for each target luminance level. Report the range of luminance values measured for 100%  $L_{max}$ .

Luminance Uniformity at $L_{max}$	76.67 - 96.13 cd/m <sup>2</sup>
Color Uniformity	2.9% in x, 4.1% in y

**Accuracy:** Repeatability error of luminance measurement should be less than 0.1%. Absolute luminance measurement accuracy is  $\pm 10\%$ . [MPR 1990:8]  
 Photometer accuracy is at least  $\pm 5\%$ . Use a measurement field covering at least 10 scanning lines for raster luminance measurement. [TEPAC Publ.105]  
 Luminance uniformity measurement results obtained by different laboratories agree to within 2%. Uncertainty of the luminance uniformity measurement is 2%. Color uniformity measurement results obtained by

different laboratories agree to within 1%. Uncertainty of the color uniformity measurement is 1%.

## 4.5 Reflectance

**Objective:** Determine the reflection coefficients of the display screen to enable the user to calculate whether the display will provide contrast modulation required for performing tasks in a particular ambient light.

**References:** ISO 9241 Part 7: Visual Displays, *Visual Display Terminals (VDTs) Used for Office Tasks - Ergonomic Requirements - Part 7: Display Requirements with Reflections Third Working Draft* Dec. 1991.

TEP105-12, *Test Method for Tube Face Reflectivity*, EIA, 1987.

MPR 1990:8 *Test Methods for Visual Display Units*, Swedish National Board for Measurement and Testing, Dec. 1990.

*VESA Standard: Display Specifications and Test Procedures Version 1.0, Rev. 1.0*, 3 October 1994.

**Equipment:**

- Photometer with 1° to 3° measurement field.
- Diffuse reflectance standard of 10% to 20 % or photographic "gray card".
- Large area (minimum 300 mm x 450 mm) light source. Uniformity of light source should be within ±5%. [MPR 1990:8]

**Test Pattern:** None

**Procedure:** Calculate reflected luminance from measured specular and diffuse reflection factors using methods described in ISO 9241 Part 7 *Normative Annex A - Simplified reflection measurements*. The methods are summarized below for convenience.

The test area should be free of highly reflective surfaces which may interfere with the measurements. Determine stabilization time and calibrate the intensity of the large-area light source to within 5% using a calibrated photometer.

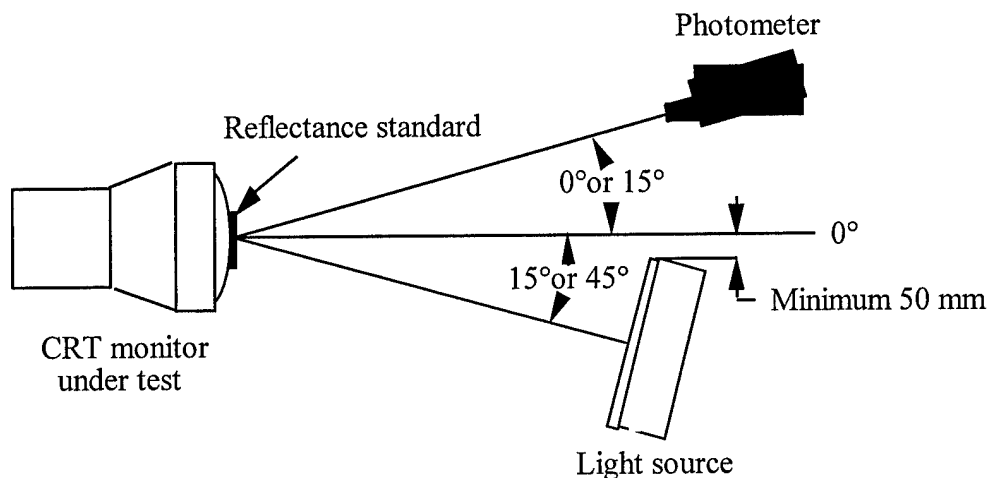

General test setup for reflectance measurement (from ISO 9241 part 7).

Figure 4.5-1

Referring to Figure 4.5-1:

- (1) Position the light source from the display screen at an angle of 15° (the specular angle) with respect to the center of the faceplate and with at least 50 mm clearance between the light source and the line perpendicular to the faceplate. Measure  $L_{R, \text{specular} + \text{diffuse}15 + \text{stray}15}$  as it is reflected off of the faceplate using a photometer positioned at the opposite -15° angle.
- (2) Without changing the test setup, cover the light source and measure  $L_{R, \text{stray}15}$ .
- (3) Uncover the light source, reposition the photometer to angle 0°, and measure  $L_{R, \text{diffuse}15 + \text{stray}0}$ .
- (4) Without changing the test setup, cover the light source and measure  $L_{R, \text{stray}0}$ .
- (5) Uncover the light source, reposition it to angle 45°, and measure  $L_{R, \text{diffuse}45 + \text{stray}0}$ .
- (6) Position the diffuse reflectance standard at the center of the display and measure  $L_{R, \text{standard}45 + \text{standard}, \text{stray}}$ .
- (7) Without changing the test setup, cover the light source and measure  $L_{R, \text{standard}, \text{stray}}$ .

- (8) Calculate the specular reflection factor:

$$R_{\text{specular}} = \frac{\{(L_{R, \text{specular} + \text{diffuse}15 + \text{stray}15} - L_{R, \text{stray}15}) - (L_{R, \text{diffuse}15 + \text{stray}0} - L_{R, \text{stray}0})\}}{L_{\text{source}}}$$

- (9) Calculate the diffuse reflection factor:

$$Q_{\text{diffuse}} = Q_{\text{diffuse,standard}} \times \left\{ \frac{(L_{R,\text{diffuse}45} + \text{stray}0 - L_{R,\text{stray}0})}{(L_{R,\text{standard}45} + \text{standard, stray} - L_{R,\text{standard, stray}})} \right\}$$

**Analysis:** Diffuse reflection of ambient light will modify the contrast modulation measured as described in Section 5.2 in a darkened environment. The reflected ambient light will contribute equally to the dark regions (background) and bright regions of a pattern. The effect of this contribution on the contrast ratio observed in a lighted environment is illustrated by the example shown in Figure 4.5-2 below.

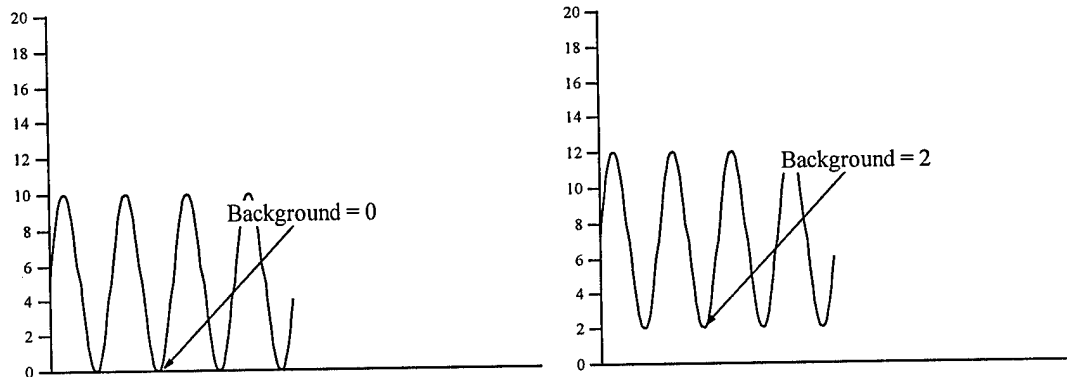

$$C_m(\text{out}) = \frac{L_{\text{peak}} - L_{\text{valley}}}{L_{\text{peak}} + L_{\text{valley}}} = \frac{10 - 0}{10 + 0} = 1.0 \quad C_m(\text{out}) = \frac{12 - 2}{12 + 2} = 0.714$$

*Reflected ambient light degrades contrast modulation by adding equaling to the peaks and valleys of the luminance profile.*

**Figure 4.5-2**

The effective value  $C'_m$  of the contrast modulation in the presence of ambient illumination  $I_{\text{ambient}}$  ( $\text{lm}/\text{m}^2$ , or lux) can be obtained as follows from a value of  $C_m$  measured in the dark as described in Section 5.2, and the value of  $q$  measured as described above.

The luminance  $L_{\text{ambient}}$  due to ambient illumination,  $I_{\text{ambient}}$ , reflected from the screen is

$$L_{\text{ambient}} = \frac{I_{\text{ambient}} q_{\text{diffuse}}}{\pi} \quad (\text{cd}/\text{m}^2, \text{ or nits})$$

The effective value  $C'_m$  is then given by

$$C'_m = \frac{C_m}{1 + \frac{L_{\text{ambient}}(1 + C_m)}{L_{\text{peak}}}}$$

In the equation above,  $L_{\text{peak}}$  is the peak luminance of the pattern measured in the dark as described in Section 5.2.

It should be noted that the effective value of the contrast modulation is also affected by halation. As described in Section 4.6, halation is a nonlocal phenomenon. The effects of halation on the contrast modulation cannot be described in a simple way. At any one part of the screen they depend on the details of the displayed pattern at all other parts of the screen.

**Data:** TBD

**Accuracy:** TBD

## 4.6 Halation

**Objective:** Measure the contribution of halation to contrast degradation. Halation is a phenomenon in which the luminance of a given region of the screen is increased by contributions from surrounding areas caused by light scattering within the phosphor layer and internal reflections inside the glass faceplate. The mechanisms that give rise to halation, and its detailed non-monotonic dependence on the distance along the screen between the source of illumination and the region being measured have been described by E. B. Gindele and S.L. Shaffer. The measurements specified below determine the percentage of light that is piped into the dark areas as a function of the extent of the surrounding light areas.

**References:** TEP105-10, *Contrast Measurement of CRTs*, EIA, 1987.

ISO 9241 Part 7: Visual Displays, *Visual Display Terminals (VDTs) Used for Office Tasks - Ergonomic Requirements - Part 7: Display Requirements with Reflections Third Working Draft*, Dec. 1991.

Gindele, E.B., and Shaffer, S.L., *A Physical Optics CRT Faceplate Halation Model*, SID 90 Digest, p. 446 (1990).

Tannas, Jr., Lawrence E., *Flat-Panel Displays and CRTs*, Van Nostrand Reinhold, NY, p. 163 (1985).

**Equipment:**

- Photometer
- Video generator

**Test Pattern:**

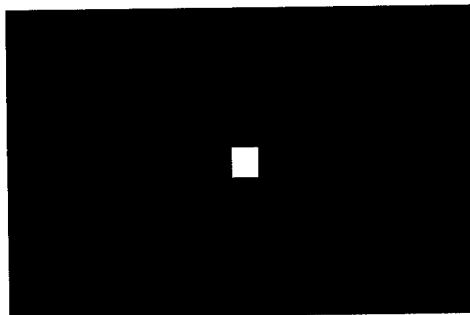

*Square box, 1% screen area in size  
for establishing the input count level for 75%  $L_{max}$ .*

**Figure 4.6-1**

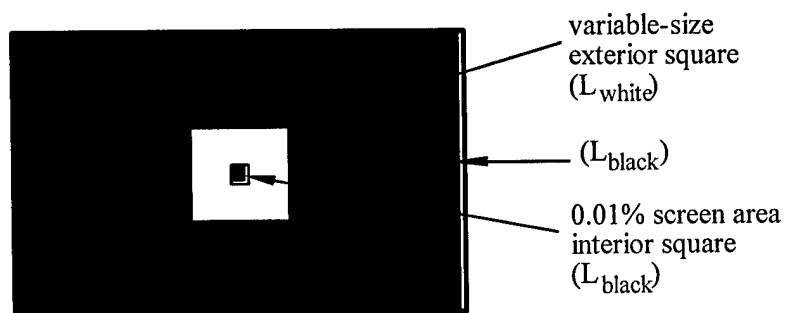

*Interior and exterior square boxes for measuring halation.*

**Figure 4.6-2**

**Procedure:** Note: The halation measurements require changing the setting of the BRIGHTNESS control and will perturb the values of  $L_{max}$  and  $L_{min}$  that are established during the initial monitor set-up. The halation measurements should therefore be made either first, before the monitor setup, or last, after all other photometric measurements have been completed.

Determine halation by measuring the luminance of a small square displayed at  $L_{black}$  (essentially zero) and at  $L_{white}$  when surrounded by a much larger square displayed at  $L_{white}$  (approximately 75%  $L_{max}$ ).

Establish  $L_{black}$  by setting the display to cutoff. To set the display to cutoff, display a flat field using video input count level zero, and use a photometer to monitor the luminance at center screen. Vary the BRIGHTNESS control until the CRT beam is visually cut off, and measure the corresponding luminance ( $L_{stray}$ ). Fine tune the BRIGHTNESS control such that CRT beam is just on the verge of being cut off. These measurements should be made with a photometer which is sensitive at low light levels (below  $L_{min}$  of the display). Make no further adjustments or changes to the BRIGHTNESS control or the photometer measurement field.

Next, establish the input counts required for  $L_{white}$  by displaying a square box, 1% addressable screen area in size in the center of the CRT as shown in Figure 4.6-1. Measure and record the luminance  $L_{max}$  produced by exciting this patch to the maximum permitted input count. Decrease the video input level to display a measured luminance of 75%  $L_{max}$  on the square patch. Measure and record this luminance ( $L_{white}$ ).

The test target used in the halation measurements is a black ( $L_{black}$ ) square patch of width equal to 0.01% of the area of addressable screen, the interior square as shown in Figure 4.6-2. The interior square patch is

enclosed in a white ( $L_{\text{white}}$ ) variable-width square, the exterior square as shown in Figure 4.6-2. The exterior square will be displayed at 75%  $L_{\text{max}}$  using the input count level for  $L_{\text{white}}$  as determined above. The pixel width of the exterior square will be stepped from 5% to 100% of the full screen linear width in 5% increments. The interior square and the area surrounding the exterior square will be displayed at input digital count level zero.

Displaying the test targets shown in Figure 4.6-2, measure the luminance in the interior black square ( $L_{\text{black}}$ ). Care must be taken during the luminance measurement to ensure that the photometer's measurement field is less than one-half the size of the interior square and is accurately positioned not to extend beyond the boundary of the interior square. The photometer should be checked for light scattering or lens flare effects which allow light from the surround to enter the photosensor. A black card with aperture equal to the measurement field (one-half the size of the interior black square) may be used to shield the photometer from the white exterior square while making measurements in the interior black square.

Then display the interior square using the input count level for  $L_{\text{white}}$  as determined above, and measure the luminance in the interior square ( $L_{\text{white}}$ ). Repeat this process, measuring  $L_{\text{black}}$  and  $L_{\text{white}}$  in the interior square for each size of the exterior square from 5% to 100% full screen.

**Analysis:** Compute the percent halation for each test target configuration. Percent halation is defined as

$$\% \text{ Halation} = L_{\text{black}} / (L_{\text{white}} - L_{\text{black}}) \times 100$$

Where,  $L_{\text{black}}$  = measured luminance of interior square displayed at  $L_{\text{black}}$  using input count level zero,

$L_{\text{white}}$  = measured luminance of interior square displayed at  $L_{\text{white}}$  using input count level determined to produce a full screen luminance of 75%  $L_{\text{max}}$ .

**Data:** Tabulated values of  $L_{\text{black}}$  and  $L_{\text{white}}$  as a function of the size of the exterior square.

**TABLE 4.6-I. Sample Data for Halation**

Size of Exterior Square	Lw (75% Lmax) = 114.35 cd/m <sup>2</sup>			
	Luminance of Interior Square (cd/m <sup>2</sup> )			
% Raster	Lb	Lw	Lw-Lb	% Halation
5	2.71	106.99	104.28	2.6
20	4.76	115.35	110.59	4.3
40	5.48	114.11	108.63	5.0
60	5.96	116.31	110.35	5.4
80	6.24	118.67	112.44	5.5
full screen	5.17	97.91	92.74	5.6

**Output:** Report the maximum percentage halation.

Halation	= 5.6%
----------	--------

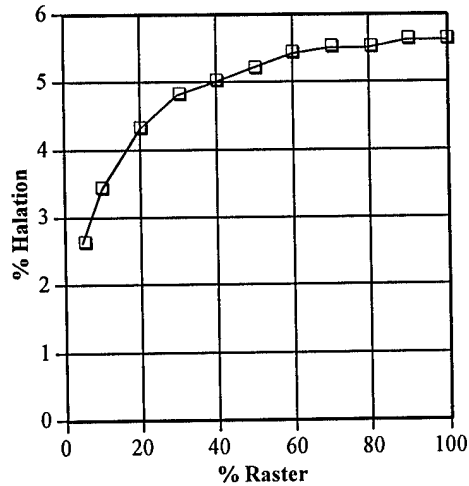

*Sample plot of halation.*

**Figure 4.6-3**

**Accuracy:** Repeatability error of luminance measurement should be less than 0.1%. Absolute luminance measurement accuracy is  $\pm 10\%$ . [MPR 1990:8] Photometer accuracy is at least  $\pm 5\%$ . Photometer should be checked for light scattering or lens flare effects which allow light from the surround to enter the photosensor.

#### 4.7 Contrast Ratio

**Objective:** Calculate large area contrast ratio using measured results for halation and screen reflectance.

**References:** TEP105-10, *Contrast Measurement of CRTs*, EIA, 1987.

*VESA Standard: Display Specifications and Test Procedures Version 1.0, Rev. 1.0*, 3 October 1994.

**Equipment:**

- Photometer
- Video generator

**Test Pattern:**

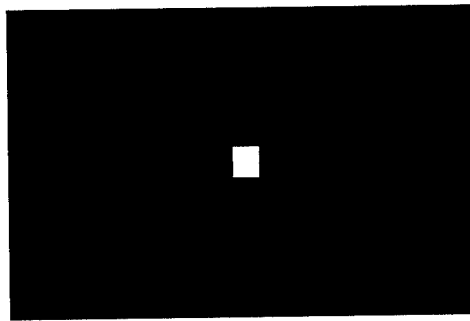

*Square box, 1% screen area in size  
for establishing the input count level for 75%  $L_{max}$ .*

**Figure 4.7-1**

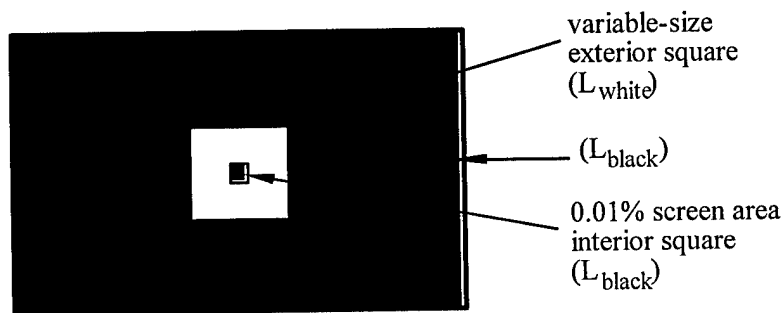

*Interior and exterior square boxes for measuring halation.*

**Figure 4.7-2**

**Procedure:** Measure diffuse reflectance normal to the display screen using a diffuse light source at 45° and standard reflectance card according to Section 4.5 Reflectance.

From the measured value, calculate the reflected luminance  $L_{diffuse}$ , from an assumed standard ambient illumination.

Measure luminance  $L_{halation}$  due to halation. This is measured in Section 4.6 Halation on a small dark area with full-screen surround of 75%  $L_{max}$  luminance, which is assumed to be a moderate luminance for imagery applications.

**Analysis:** Calculate contrast ratio as ratio of luminance of peak brightness to dark regions:

$$C.R. = \frac{L_{peak} + L_{diffuse} + L_{halation}}{L_{diffuse} + L_{halation}}$$

where:

$L_{peak}$  is the maximum luminance of the display ( $L_{max}$ )

$L_{halation}$  is the luminance due to halation from a 75%  $L_{max}$  image

$L_{diffuse}$  is the portion of the ambient illumination reflected by the display screen.

**Sample Data:** TBD

**Output:** TBD

**Accuracy:** Luminance measurement accuracy is  $\pm 10\%$ . [MPR 1990:8] Photometer accuracy is at least  $\pm 5\%$ . Use a measurement field covering at least 10 scanning lines for raster luminance measurement. [TEPAC Publ.105]

## 4.8 Lifetest

**Objective:** Over time, measure the changes in nonlinear photometric characteristic (output luminance versus input drive) of the display as it spans  $L_{\min}$  to  $L_{\max}$ . Determine changes in gamma value over time.

**Equipment:**

- Photometer
- Video signal generator

**References:** *VESA Standard: Display Specifications and Test Procedures Version 1.0, Rev. 1.0*, 3 October 1994.

### Test Pattern:

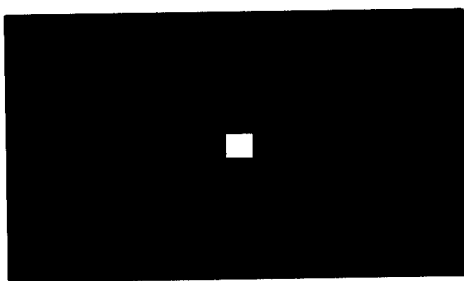

*Square box, 1% screen area  
Use this pattern to determine  
end of life.*

**Figure 4.8-1**

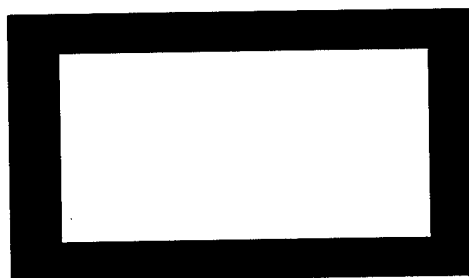

*Full Screen Flat Field displayed at  
50%  $L_{\max}$*

*Use this pattern to age the display*

**Figure 4.8-2**

**Procedure:** A full screen flat field test pattern producing 50%  $L_{\max}$  is continuously displayed. Repeated measurements of luminance as a function of input count levels are performed at intervals of 168 hours (1 week) until the specified dynamic range of the display ( $L_{\max}$  to  $L_{\min}$ ) can no longer be achieved, signifying the end of life of the display.

#### *Determining end of life*

At each measurement interval, the BRIGHTNESS and CONTRAST controls are temporarily readjusted in an attempt to *regain* the original dynamic range of the monitor under test to  $L_{\min} = 0.01 \text{ cd/m}^2$  (0.003 fL) and  $L_{\max}$  as specified by the manufacturer.

With video input level set to black (zero count level) the BRIGHTNESS control is temporarily readjusted to regain a background raster equal to  $L_{\min}$  with a test target which is specified by the manufacturer. If no such target is specified by the manufacturer, one may use a square patch as shown in Figure 4.8-1 equal in size to 1% of the area of the addressable screen, and set to count 0 at center screen. Using the same test target at the maximum input count level (255 for 8-bit systems, 1023 for 10-bit systems, 4095 for 12-bit systems) temporarily readjust the CONTRAST control to regain  $L_{\max}$ . The display is considered to have reached its *end of life* when the original values  $L_{\min}$  and  $L_{\max}$  can no longer be achieved with a single setting of the BRIGHTNESS and CONTRAST controls.

If the display has not reached end of life, then return the BRIGHTNESS and CONTRAST controls to their original positions, and return the display to a full screen flat field pattern with input video level set for producing luminance equal to 50%  $L_{\max}$ . Each week, a slightly different input count level will be required to produce 50%  $L_{\max}$  due to ageing of the display.

**Data:** Tabulate the input count to luminance transfer characteristic for the above test target 1% screen area square box shown in Figure 4.8-1

**TABLE 4.8-I.** Sample Lifetest Data Sheet

Input Count	Luminance			
	at 2 hours	at 170 hours	at 344 hours	at . . .
0	_____ cd/m <sup>2</sup>	_____ cd/m <sup>2</sup>	_____ cd/m <sup>2</sup>	_____ cd/m <sup>2</sup>
6	_____ cd/m <sup>2</sup>	_____ cd/m <sup>2</sup>	_____ cd/m <sup>2</sup>	_____ cd/m <sup>2</sup>
12	_____ cd/m <sup>2</sup>	_____ cd/m <sup>2</sup>	_____ cd/m <sup>2</sup>	_____ cd/m <sup>2</sup>
18	_____ cd/m <sup>2</sup>	_____ cd/m <sup>2</sup>	_____ cd/m <sup>2</sup>	_____ cd/m <sup>2</sup>
24	_____ cd/m <sup>2</sup>	_____ cd/m <sup>2</sup>	_____ cd/m <sup>2</sup>	_____ cd/m <sup>2</sup>
.	.	.	.	.
.	.	.	.	.
255	_____ cd/m <sup>2</sup>	_____ cd/m <sup>2</sup>	_____ cd/m <sup>2</sup>	_____ cd/m <sup>2</sup>

**Analysis:** Prepare a log graph of the data.

**Output:** See lifetest plot in Figure 4.8-3 below.

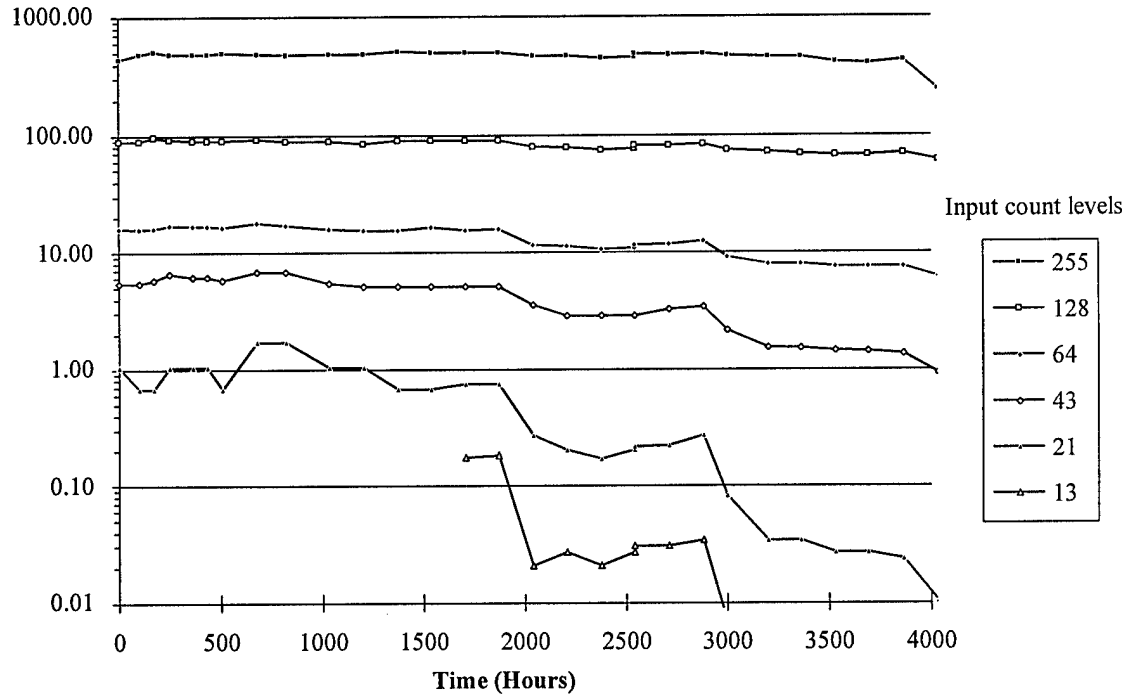

*Log plot of luminance as a function of time showing effects of aging with constant settings of BRIGHTNESS and CONTRAST controls.*

**Figure 4.8-3**

**Accuracy:** Repeatability error of luminance measurement should be less than 0.1%. Absolute luminance measurement accuracy is  $\pm 10\%$ . [MPR 1990:8] Photometer accuracy is at least  $\pm 5\%$ . Use a measurement field covering at least 10 scanning lines for raster luminance measurement. [TEPAC Publ.105]

## 4.9 Display Spatial Noise

**Objective:** To characterize the spatial noise of the display (due primarily to inhomogenities in the phosphor screening). The procedure specified for this measurement is applicable to uniform-screen (e.g., monochrome or penetration) CRTs, but not to patterned screen (e.g., shadow mask or beam index) CRTs. Spatial noise is usually the major contributor to the degradation of the information content of a display from the value implied by the number of resolvable pixels and gray levels.

**References:** Roehrig, H., et. al., *Signal-to noise ratio and maximum information content of images displayed by a CRT*, Proc. SPIE **1232**, 115-133 (1990).

**Equipment:** Video generator  
Spatially calibrated photodiode linear array

**Test Pattern:** A number  $N_L$  of successive horizontal scan lines (typically 100) of full horizontal width and vertically centered on the screen, with line intensity commanded to maximum level for all pixels (uniform scan lines).

**Procedure:** The photodiode linear array should be the type for which the dimension of each photosensitive element perpendicular to the array direction is much greater (typically by a factor of 100) than the dimension along the array direction. Use a lens to image the test pattern onto the array at a known magnification. The array should be orientated so that the long dimension of each of its elements is parallel to the vertical direction of the display. The magnification and the value of  $N_L$  should be selected so that the vertical height of the image falls completely within the width of the sensor in this direction. The magnification should also be such that the width of the horizontal scan completely overlaps the width of the sensor.

The output levels from each element of the array should be measured and recorded channel by channel. Relative levels are sufficient; absolute values are not required. The integration period should be set reasonably long (e.g. over 30 frames) to average as much as possible over the temporal noise of the display. If necessary, neutral density filters should be incorporated into the system to ensure that the detector is not overloaded. The measurement should be repeated and results compared to make certain that the temporal noise (typical variation among measurement for a given channel) is small compared to the spatial noise (variation between the channels within a single measurement). If necessary, the results from a number of measurements should be

averaged channel-by-channel to ensure that the variation are due primarily to spatial noise, rather than to a combination of spatial and temporal noise. (For typical displays and integration times the last procedure will generally be unnecessary)

**Data:** The signal levels  $s_i$  in each of the  $N_C$  (typically 512) display channels, averaged, if required, as described above.

**Analysis:** The average level  $\bar{s}$  of the signal is

$$\bar{s} = \frac{1}{N_C} \sum_{i=1}^{N_C} s_i .$$

The standard deviation  $s_C$  (rms noise) per channel is

$$\sigma_C = \left[ \frac{(s_i - \bar{s})^2}{N_C - 1} \right]^{1/2} .$$

The signal-to-noise ratio  $(S/N)_C$  on a per-channel basis is

$$(S/N)_C = \frac{\bar{s}}{\sigma_C} .$$

The number of pixels  $N_P$  that illuminate a single channel is

$$N_P = \frac{N_L w_e}{M w_P} ,$$

where  $N_L$  is the number of horizontal lines in the display,  $w_e$  is the sensitive width of each detector element along the array direction,  $M$  is the display-to-sensor magnification factor of the lens system, and  $w_P$  is the pixel width as measured on the display. (The last quantity is preferably obtained from, e.g, a measurement of the vertical line width as described in section 4.2 of this publication. The signal-to-noise ratio  $(S/N)_P$  on a per-pixel basis is

$$(S/N)_P = \frac{(S/N)_C}{N_P^{1/2}} .$$

The number  $n$  of bits of information per pixel, as determined by the measured spatial noise of the display is

$$n = \frac{\log \left[ 1 + (S/N)_P \right]}{\log 2} .$$

This page intentionally left blank.

## 5.0 RESOLUTION CHARACTERIZATION

### 5.1 Line Width

**Objective:** Characterize line width profile of the CRT display. This measurement is used for the determination of resolution. The relationship between vertical and horizontal line width is an indication of the beam spot (pixel) shape. Luminance calibration is not required for this measurement unless absolute luminance is measured.

**References:** TEP105-7-A, *Line Profile Measurements in Monochrome CRTs*, EIA, 1987.

TEP105-9, *Line Profile Measurements in Shadowmask and Other Structured Screen CRTs*, EIA, 1987.

TEP105-17, *MTF Test Method for Monochrome CRT Display Systems*, EIA, 1990.

TEP192, *The Glossary of CRT Terms and Definitions*, EIA, 1984.

TEB25, *A Survey of Data Display CRT Resolution Measurement Techniques*, EIA, 1985.

TEB27, *Relating Display Resolution and Addressability*, EIA, 1988.

Beaton and Farley, *Display Measurement Issues in the ANSI/HFS 100-1988 Standard*, SID'91 Digest, p. 648.

Farrell, Richard J., and Booth, John M., *Design Handbook for Imagery Interpretation Equipment*, Boeing Aerospace Co., 1984.

ARP1782, *Photometric and Colorimetric Measurement Procedures for Airborne Direct View CRT Displays*, SAE, Jan. 1989.

ISO/TC159/SC4 WG2/N219 *Final Text for IS 9241 Part 3; Visual Displays*, Dec. 1990.

*VESA Standard: Display Specifications and Test Procedures Version 1.0, Rev. 1.0*, 3 October 1994.

**Equipment:** Video generator  
Spatially calibrated CCD or diode optics

Test pattern: Use the three-line pattern in Figure 5.1-1 to display vertical or horizontal lines each 1-pixel wide. Position lines in video to each test location as shown in Figure 5.1-2. The locations of corner screen test points are arbitrarily defined to be severe enough to adequately evaluate the resolution capabilities of CRTs used to display high pixel-density imagery.

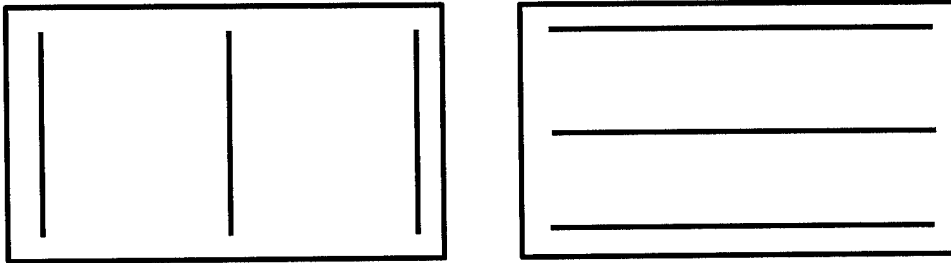

1-pixel wide lines at 50%  $L_{max}$

*Three-line Grille Test Patterns*

**Figure 5.1-1**

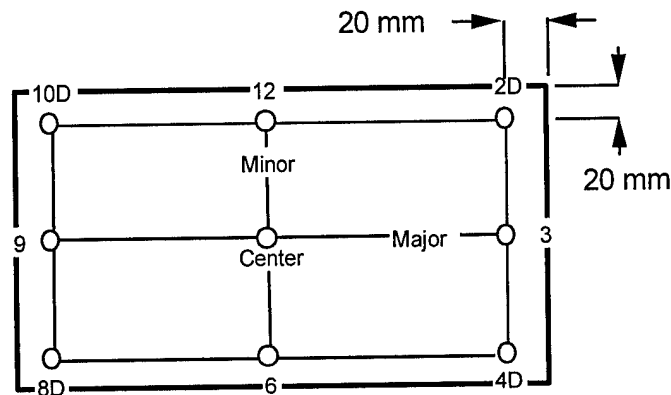

*Nine Screen Test Locations*

*Clock positions reference test positions which are symmetrically spaced 20 mm inside the addressable screen edges.*

**Figure 5.1-2**

**Procedure:** Deflected Line Width: Use moving beam method, scanning slit method, or photodiode (or CCD) array to measure full-width at half maximum (FWHM) vertical and horizontal line widths as displayed using single-line video test patterns. Measure line profile widths at 5% and 50% peak luminance for horizontal and vertical lines displayed at 50%  $L_{max}$  at nine (9) screen locations: center, ends of major and minor axes, and four corners shown in Figure 5.1-2.

Optional measure of line width with brightness: Obtain line width measurement for individual beams and white at screen center only for four commanded input levels corresponding to: 25%, 50%, 75%, and 100%  $L_{max}$  as determined in Section 3.0.



**Data:** Sample deflected Line Width Measurements (measure both horizontal and vertical lines)

**Table 4.1-I** Linewidth (FWHM) in mm for single-pixel lines at 50% Lmax

Screen positions are indicated by position in sub-table.

**H** = Horizontal width of vertical lines.

**V** = Vertical height of horizontal lines.

H	V	H	V	H	V
0.399	0.290	0.249	0.325	0.348	0.315
0.348	0.254	0.328	0.287	0.373	0.254
0.368	0.262	0.246	0.310	0.394	0.259

**Analysis:** Quantify line width uniformity by reporting vertical and horizontal line widths separately (H x V). Report line width data in same format as Table 4.1-II below.

**Table 4.1-II** Sample reported linewidth data

50% Linewidth (HxV):	
center	0.328 x 0.287 mm (12.9 x 11.3 mils)
average periphery	0.340 x 0.284 mm (13.4 x 11.2 mils)
worst location (@ 10:00)	0.399 x 0.290 mm (15.7 x 11.4 mils)

Worst location is defined as the test location on the screen where the maximum combined horizontal and vertical linewidth occurs. The combined linewidth is the magnitude calculated using square-root of the sum of the squares:

$$(H^2 + V^2)^{1/2},$$

where H is horizontal linewidth and V is vertical linewidth of white lines.

Optional line width measurements at 50% level in RAR [TEB27]

(RAR) Report horizontal and vertical line widths as Resolution-Addressability Ratio at nine screen positions.

$$RAR = R / A$$

where:

R = full width at half maximum of the line.

A = inter-pixel distance

**Output:** See sample Figure 5.1-3

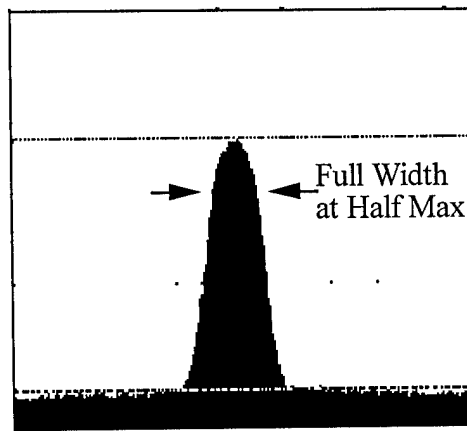

*Sample Display of Line Width  
Measurement using Diode Optics  
on Monochrome Screen*

**Figure 5.1-3**

**Accuracy:** Linewidth measurement results obtained by different laboratories agree to within 0.05mm. Uncertainty of the linewidth measurement is 9%.

## 5.2 Contrast Modulation

**Objective:** Quantify contrast modulation as a function of spatial frequency and screen position through measurements of luminance profiles. Measure contrast modulation in both horizontal and vertical directions as a function of spatial frequency over a range of luminance levels of the CRT display. This measurement is required for the determination of resolution, and provides information on the large and small signal handling capabilities of the display system. Spatial resolution capabilities of the display may or may not be closely correlated with the addressability. Spatial resolution in monochrome displays is a function of the addressability and the size and shape of the spot.

**References:** TEB27, *Relating Display Resolution and Addressability*, EIA, 1988.

Beaton and Farley, *Display Measurement Issues in the ANSI/HFS 100-1988 Standard*, SID'91 Digest, p. 648.

Briggs, S. J., *Soft Copy Display of Electro-Optical Imagery*, SPIE Vol. 762 Electro-Optical Imaging Systems Integration (1987), pp 153-

170.

ISO 9241 Part 3: Visual Displays, "Visual Display Terminals (VDTs) Used for Office Tasks - Ergonomic Requirements - Part 3: Visual Displays Final Text" as of June 1992.

TEB25, *A Survey of Data Display CRT Resolution Measurement Techniques*, EIA, 1985.

ARP1782, *Photometric and Colorimetric Measurement Procedures for Airborne Direct View CRT Displays*, SAE, Jan. 1989.

Keller, Peter, *The EIA Standard for MTFs of Monochrome CRTs*, SID 89 DIGEST, pp 204 - 207.

Miller, A. and Murray, W.J., *Fourier-Transform Methods for Determination of Contrast-Modulation Indices from Luminance-Variation Data* SID 94 Digest, pp 531-534.

*VESA Standard: Display Specifications and Test Procedures Version 1.0, Rev. 1.0*, 3 October 1994.

**Equipment:**

- Video generator
- Spatially calibrated CCD or photodiode array optic module
- Photometer with linearized response



The locations of the test points in the corners of the screen and at the ends of the major and minor axes are typically taken to be 20 mm from each edge though this can be modified if necessary to provide a more meaningful test. Guidance for the use of alternate test locations is provided in Appendix B.

Measure relative  $L_{\text{peak}}$ ,  $L_{\text{valley}}$ , over a distance of multiple cycles of high and low states in the grille pattern as shown in Figure 5.2-3 below.

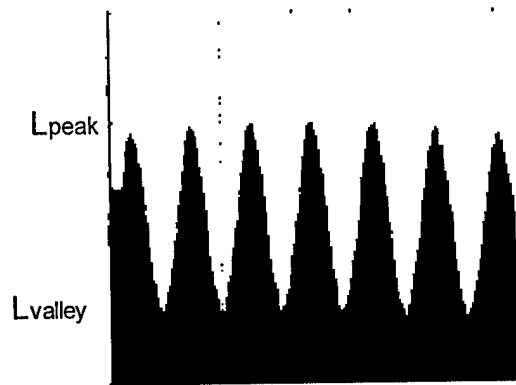

*Sample display of contrast modulation measurements using diode optics on monochrome screen.*

**Figure 5.2-3**

### ***Large signal contrast modulation***

Calculate contrast modulation ( $C_m$ ) for a range of video input levels for high and low states depicted in Figure 5.2-5 in two complementary measurement series:

- (1) The *Pin-to-Level-0* series is used to measure contrast at various luminance levels for the High-pixel with the Low-pixel pinned to Level-0.
- (2) Similarly, the *Pin-to-Level-100* series is composed of various luminance levels for the Low-pixel with the High-pixel pinned to Level-100. The two series of input levels are defined in Table 5.2-I.

### Large Signal Contrast

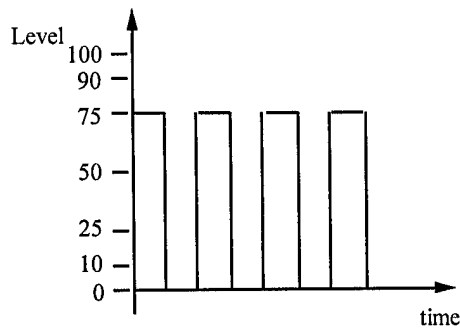

*Input signal for measuring large  
signal contrast modulation  
Pin-to-Level-0 series.*

**Figure 5.2-4**

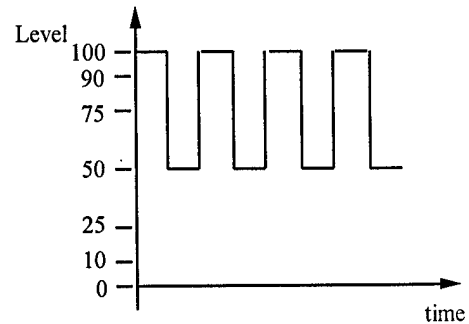

*Input signal for measuring large  
signal contrast modulation  
Pin-to-Level-100 series.*

**Figure 5.2-5**

**TABLE 5.2-I**

Video input levels for Level-p/Level-v  
(Use input counts determined  
in Section 3.0 for p and v)

*Pin-to-Level-0 series*

Level-100/Level-0

Level-75/Level-0

Level-50/Level-0

Level-25/Level-0

Level-10/Level-0

*Pin-to-Level-100 series*

Level-100/Level-90

Level-100/Level-75

Level-100/Level-50

Level-100/Level-25

Level-100/Level-0

***Small signal contrast modulation***

Measure small signal ( $\pm 5\% L_{\max}$ ) contrast modulation in both vertical and horizontal directions at nine screen locations shown in Figure 5.2-2 using video grille test patterns as shown for screen center in Figure 5.2-3 of  $n$  pixels at Level-p,  $n$  pixels Level-v ( $n=1,2,3$ ) vertical or horizontal lines on a flat field (full screen) background commanded to the

specified luminance. Measure relative  $L_{\text{peak}}$ ,  $L_{\text{valley}}$ , and calculate contrast modulation ( $C_m$ ) for a range of background luminance levels. The series of video input levels are defined in Table 5.2-II and depicted in Figure 5.2-6.

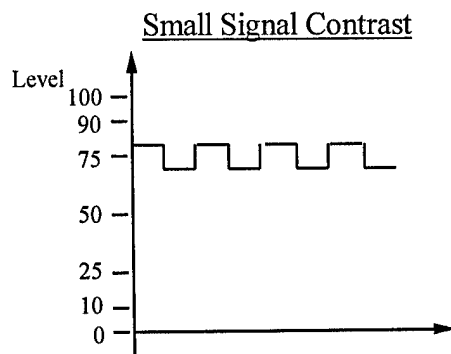

*Input signal for measuring small signal contrast modulation.*

**Figure 5.2-6**

**TABLE 5.2-II**  
 Video Input Levels for Background Luminance  
 and for Grille Luminance, Level-p/Level-v  
 (Use input counts determined in  
 Section 3.0 for p and v)

<u>Background Luminance *</u>	<u>Grille Luminance</u>
Level-90	Level-95/Level-85
Level-75	Level-80/Level-70
Level-50	Level-55/Level-45
Level-25	Level-30/Level-20
Level-10	Level-15/Level-5

\* Halation effects on small signal contrast modulation can be reduced by setting the background luminance to  $L_{\min}$  for the series listed in Table 5.2-II.

**Analysis:** For each series of contrast modulation data, compute the ratio  $C_m(\text{out}) / C_m(\text{in})$  as a function of the spatial frequency of the test pattern to evaluate the capability of the display to accurately reproduce the input test pattern.  $C_m(\text{out})$  is calculated using the measured luminance on the screen while  $C_m(\text{in})$  is calculated using the luminance displayed by the input signal count level established in Section 3.0 for the monitor under test.

Quantify contrast modulation in terms of frequency response at screen center, average 6-12, average 3-9, and average corner screen locations.

Calculate  $C_m(\text{in})$  from video signal input voltage levels:

$$C_m(\text{in}) = \frac{\text{Level-p} - \text{Level-v}}{\text{Level-p} + \text{Level-v}} \quad \text{Eq. 1}$$

Calculate  $C_m(\text{out})$  from output luminance measured on the display screen:

$$C_m(\text{out}) = \frac{L_{\text{peak}} - L_{\text{valley}}}{L_{\text{peak}} + L_{\text{valley}}} \quad \text{Eq. 2}$$

For some monitors, particularly those for which the electron beam spot width (resolution) is small compared to the inter-pixel distance (addressability), the method just described for calculating  $C_m(\text{out})$  may

become inappropriate. In such cases alternate methods for processing the measured luminance data are recommended.

The reason why the method above may become inappropriate can be understood by considering the hypothetical extreme case that the electron beam spot width is so small that the luminance level  $L_{\text{valley}}$  falls essentially to zero (i.e.,  $L_{\text{min}}$ ) in the valleys between the illuminated beam spots. The expression above for  $C_m(\text{out})$  would, in this case, have a value close to 1 regardless of the values of the video input levels. The calculated ratios  $C_m(\text{out})/C_m(\text{in})$  could then have values greater than 1. Although the behavior for actual monitors will not be as extreme as just described, instances have been encountered for which  $C_m(\text{out})/C_m(\text{in})$  calculated by the method just described is greater than 5.5.

A typical luminance modulation pattern observed for a monitor with small spot width is illustrated below.

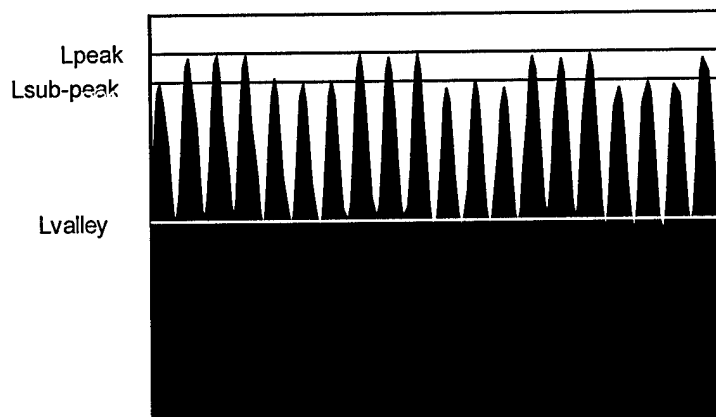

*Sample display of contrast modulation measurements  
(3 pixels at level 95, 3 pixels at level 85)  
for monitor with small spot width.*

**Figure 5.2-7**

The observed variation of luminance suggests that the contrast modulation can reasonably be defined by using, in the expression above for  $C_m(\text{out})$ , the value  $L_{\text{sub-peak}}$ , defined by the line through the peaks corresponding to the pixels at the lower input signal level, rather than the value  $L_{\text{valley}}$ .

This technique cannot, however, be applied to all sets of measurements. For some luminance patterns the subsidiary peaks appear only as shoulders, or are altogether absent. Values of  $L_{\text{peak}}$  and  $L_{\text{sub-peak}}$  (or  $L_{\text{valley}}$ ) suitable for use in the expression above for  $C_m(\text{out})$  cannot then be obtained in an objective and reliable way.

A second alternative that is based on the Fourier transform of the luminance pattern is recommended because it can be used to infer an objective value of the MTF regardless of the shape of the modulation pattern. The method lends itself to computerized extraction of modulation contrast values from large sets of measured luminance patterns. To apply this method, the data representing the spatial variation in luminance should be at discretely sampled, equally spaced intervals. The spatial range of the data should include at least 6 periods of the modulation pattern. It is also necessary to determine, within an accuracy of 10-15%, the number of discretely sampled channels  $n_p$  per pixel width.

The data are analyzed by (1) calculating the Fourier transform of the luminance distribution, (2) subtracting the contribution to the transform from the peak centered about zero frequency, (3) determining the effective amplitudes of the peaks, and (4) calculating an appropriately defined MTF. These steps are described below in more detail.

1. For each measured luminance distribution a discrete Fourier transform  $L_f$  is calculated as shown in Eq. 3:

$$L_f = \frac{1}{\sqrt{N}} \sum_{j=0}^{N-1} w_j l_j \exp \left( - \frac{2\pi i j f}{N} \right), f=0, \dots, N-1 \quad \text{Eq. 3}$$

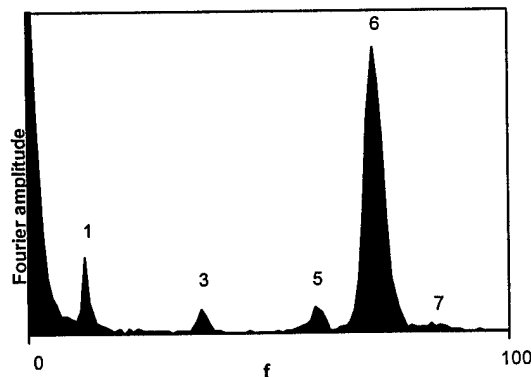

*Fourier transform of luminance distribution in Figure 5.2-7. The peaks labeled 1, 3, 5, 6, and 7 are respectively the first, third, fifth, sixth, and seventh harmonics of the fundamental input frequency.*

**Figure 5.2-8**

In Eq. 3,  $L_f$  is the (complex-valued) component of the transform at spatial frequency  $f$ ,  $N$  is the number of adjacent measured channels, typically 512, in each region of the display, and  $l_j$  is the scaled luminance measured at the  $j$ -th channel. The factors  $w_j$  are components of a windowing array that is introduced to reduce effects due to aliasing components at a given frequency into neighboring discrete frequencies, and effects due to

mismatch of the luminance distribution at the two ends of the measured range. A modified Welch windowing array,

$$w_j = C \left( \frac{j}{N} - \frac{j^2}{N^2} \right) \quad \text{Eq. 4}$$

was found to be satisfactory. In Eq. 4,  $C$  is normalizing constant that can be given an arbitrary value. (In our software,  $C$  is assigned the value  $\sqrt{30}$ , which makes the sum of the squares of  $w_j$  essentially equal to 1.)

Plots of the amplitudes (the absolute values  $|L_f|$ ) of the components of the Fourier transforms of the luminance distribution in Figure 5.2-7 is shown in Figure 5.2-8. Especially for displays that are sampled, e.g., by an aperture mask, inspection of a few of the transform plots can provide useful insights. The spatial frequencies at which peaks are found to occur in the transform can generally be identified in terms of the properties of the input and sampling patterns. In Figure 5.2-8 the peaks labeled 1, 3, 5, 6, and 7 are respectively the first, third, fifth, sixth, and seventh harmonics of the fundamental input frequency. Identification of these peaks can be useful in resolving issues such as whether aliasing interactions between harmonics of the input and sampling spatial frequencies can perturb the response near the signal frequency (diminished or falsely-enhanced contrast modulation) or near zero frequency (moiré).

As an example, a commercial delta-mask display was measured for which the sampling frequency in one direction was almost exactly equal to the spatial frequency of adjacent pixels. The contrast modulation of a one-on/one-off bar pattern could be made nearly to vanish in any given region on this display by a small adjustment of the raster centering.

2. The next step is to subtract the contribution to the transform from the peak centered at  $f = 0$ . This improves the accuracy of determining the contributions from low-frequency peaks such as the one in Figure 1b that is situated on the skirt of the zero-frequency peak. The contribution to be subtracted can be shown to be very nearly equal to the discrete convolution of a delta function at  $f = 0$  with the Fourier transform of  $w_j$ . This transform,  $W_f$ , is given by

$$W_0 = L_0, \\ W_f = \frac{3 L_0}{(N-1) \sin^2(\pi f/N)} \quad \text{for } 0 < f < N \quad \text{Eqs. 5}$$

(The zero-frequency component  $L_0$  is necessarily a real-valued number. Its calculated value from the transform, Eq. 3, of each luminance distribution is used to evaluate  $W_f$  via Eqs. 5.)

3. The effective amplitudes, as required, from the peaks at various spatial frequencies are then calculated. For determination of MTFs, only the contributions of the zero-frequency peak and that at the spatial frequency corresponding to the fundamental period of the input pattern are required. For other metrics, such as one to be described later that is related to  $C_m(\text{out})/C_m(\text{in})$ , contributions from higher harmonics of that period are required.

If all the peaks in the transform had the same shape and width, quantities such as the maximum value of the amplitude of the peak, or the area under the peak, could be used as the effective amplitude. It is found, however, that the peaks vary somewhat in width from one to another. The following factors have been identified as contributing to the finite and variable widths of the peaks: the effects of the windowing array and modulation of the envelope of the luminance across its measured range, the lack of strict periodicity in the measured luminance distribution because of spatial nonlinearities in the display and measuring system, and the presence of spatial frequencies in the luminance distribution that correspond to non-integer values of  $f$ .

When peak widths vary, quantities such as the maximum values of the amplitudes or the areas under the peaks are no longer accurate measures of the effective amplitudes to be used for calculating the MTF. The spectral power associated with each peak, which is defined as the sum of the products  $L_f^*L_f$  for values of  $f$  in the vicinity of the peak is, however, unaffected by the factors that cause broadening. This can be shown to be a consequence of Parseval's theorem, which for the present case can be stated

$$\sum_{j=0}^{N-1} (w_{jj})^2 = \sum_{f=0}^{N-1} L_f^* L_f \quad \text{Eq. 6}$$

and the fact that when the measured luminance distribution spans many periods of the input pattern, its mean-square value is affected little by the factors described above that lead to peak broadening: To obtain the effective amplitude in the software that was developed to analyze the data, an estimate  $f_h$  is first obtained for the spatial frequency of any desired peak at a frequency other than zero:

$$f_h = \frac{hN}{2np} \quad \text{Eq. 7}$$

In Eq. 7,  $h$  is the harmonic number of the peak (equal to 1 for the fundamental),  $n$  is the width, in pixels, of each bar in the input pattern, and  $p$  is a previously-determined value of the number of detector elements per pixel. The estimate  $f_h$  is used to locate the actual desired peak in the transform. The spectral power  $S_h$  associated with that peak is then obtained, where

$$S_h = \sum_{\text{region}} L_f^* L_f \quad \text{Eq. 8}$$

The region of the summation covers those values of  $f$  that are close to  $f_h$  for which  $L_f^* L_f$  makes a significant contribution. Because the quantities  $L_f^* L_f$  are the squares of the quantities plotted in Figures 1b and 2b, the peaks in  $L_f^* L_f$  are more completely separated than the peaks shown in the figures. The effective amplitude  $A_h$  of the peak with harmonic number  $h$  is the square root of the associated spectral power:

$$A_h = \sqrt{S_h} \quad \text{Eq. 9}$$

The contribution  $A_0$  from the peak centered about  $f = 0$  can be calculated by the method just described if it is recognized that it has components not just at  $f > 0$  but also at  $f < N$ . There is, however, a computationally more efficient way to find this contribution. Because the shape of this peak is known, as per Eq. 5, it can be shown that the contribution is

$$A_0 = \left[ 6/5 \left( 1 - \frac{1}{N^2} \right) \right]^{1/2} L_0 \quad \text{Eq. 10}$$

(For large  $N$ ,  $A_0$  is well-approximated by  $v1.2 L_0$ .)

4. The MTF of a luminance distribution produced by a digitally-addressed display whose individual pixels are commanded to specified luminance levels can be defined as follows in a way that is consistent with the definition of MTF as the Fourier transform of the line profile:

$$\text{MTF} = \frac{R_D}{R_0} \quad \text{Eq. 11}$$

In Eq. 11,  $R_D$  is the ratio of the effective amplitudes with  $h = 1$  and 0,

$$R_D = \frac{A_1}{A_0}, \quad \text{Eq. 12}$$

and  $R_d$  is the equivalent ratio for a hypothetical display whose pixel shapes are Dirac delta-functions with weights  $u_h$  or  $u_l$ , as appropriate. It can be shown by means of an expression analogous to Eq. 3 that the values of  $R_d$  for bar patterns with width  $n = 1, 2,$  and  $3$  pixels are as given in Table 5.2-III below.

**TABLE 5.2-III**  
Values  $R_d$  of the ratio  $A_1/A_0$  for ideal display with delta-function pixel shape.

N	$R_d$
1	$(u_h - u_l)/(u_h + u_l)$
2	$\frac{\sqrt{2}}{2}(u_h - u_l)/(u_h + u_l)$
3	$\frac{2}{3}(u_h - u_l)/(u_h + u_l)$

The same expression can be used to show that e.g., for a bar pattern with 3 pixels with weights  $u_h$  and 3 with weights  $u_l$ , the peaks in the Fourier transform occur only for  $h = 0, 1, 3, 5,$  and at the values just stated incremented by multiples of 6. Figure 5.2-8 shows exactly these peaks.

### **Resolution**

A contrast modulation of 25% or more is clearly perceivable and appropriate for the display of imagery. A contrast modulation of 50% or more is appropriate for the display of small-size alphanumeric information. This definition is strictly physical, not psychophysical. The psychophysical question of whether the typical human visual system resolves the pattern displayed depends on a number of other parameters including viewing distance, luminance, and pixel size. It also depends on how the performance spread of the human visual system is taken into account, e.g. one just-noticeable difference in visual detection experiments means that 75% of a group of viewers perceives the difference.

To be explicit, we define resolution by the following equation:

$$\text{Resolution} = (\# \text{ of addressable lines}) / n_r$$

where  $n_r$  is the calculated grille line width in pixels for which the value of  $C_m(\text{out})/C_m(\text{in})$  is estimated by linear interpolation to be 25% or 6dB attenuation as depicted in Figure 5.2-9.

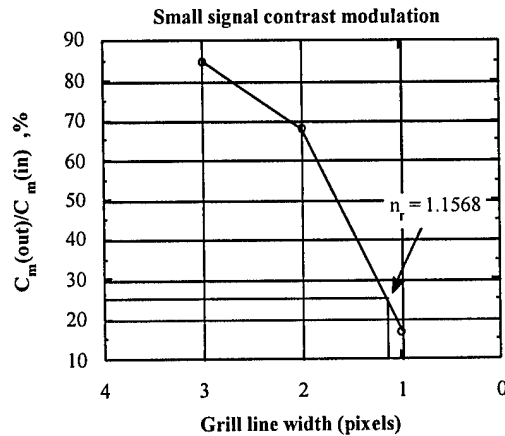

Use linear interpolation to determine the value of  $n_r$  from contrast modulation measurements.

**Figure 5.2-9**

If  $C_m(1) > 25\%$ , then  $n_r = 1$  and the resolution is equal to the number of addressable pixels. For  $C_m(1) < 25\%$ , use linear interpolation to calculate the value of  $n_r$  from the measured  $C_m$  values nearest to 25%. In general, use values of  $C_m$  such that  $C_m(n) < 25\% < C_m(n+1)$ , measured for grille patterns of  $n$ -pixels wide lines and  $(n+1)$ -pixels wide lines.

$$n_r = n + \frac{C_m(n_r) - C_m(n)}{C_m(n+1) - C_m(n)}, \text{ for } C_m(n) < 0.25 < C_m(n+1)$$

**Sample resolution calculation**

The following data are chosen for calculating resolution of a small signal grille pattern displayed at 90%  $L_{\text{max}}$  average luminance on a 1024 pixel display. (These sample contrast modulation data are also presented in Table 5.2-IV and plotted in Figure 5.2-11.)

$$C_m(\text{out})/C_m(\text{in}) = 17\% \text{ for 1-pixel grille patterns}$$

$$C_m(\text{out})/C_m(\text{in}) = 68\% \text{ for 2-pixel grille patterns}$$

Interpolate between these two data points to calculate the value of  $n_r$  for 25% modulation, that is, for  $C_m(n_r) = 25\%$ .

$$C_m(n) = 0.17, \quad n=1$$

$$C_m(n+1) = 0.68$$

$$n_r = n + \frac{C_m(n_r) - C_m(n)}{C_m(n+1) - C_m(n)} = 1 + \frac{0.25 - 0.17}{0.68 - 0.17} = 1.1568$$

$$\text{Resolution} = (\# \text{ of addressable lines}) / n_r = 1024 / 1.1568 = 885 \text{ lines}$$

Apply this criterion to the measured contrast modulation data,  $C_m(\text{out})/C_m(\text{in})$ , to assess the resolution capabilities of the display in units of pixels in both horizontal and vertical directions.

If MTFs rather than  $C_m$  values are calculated in the analysis of the data, the following alternative treatment of resolution may be used. In a manner analogous to what was described above, find from the dependence of MTF on the grille line width  $n$  in pixels, the interpolated or extrapolated value of  $n$  that corresponds to the value 0.4107 for MTF. This value of  $n$  is taken as the Resolution-Addressability Ratio (RAR) at the measured location. (For Gaussian line shapes this method gives results that are in rigorous correspondence with the standard definition of RAR.)

Because contrast modulation depends upon screen position, peak luminance, and whether the signal is small or large scale, it does not make sense to define a single resolution for the entire screen independent of image material. For a number of applications, the user needs to know if the display characteristics are varying in a way that will impact his task performance. As a minimum, report resolution at screen center and average of the four corners.

Quantify contrast modulation uniformity by reporting vertical and horizontal contrast modulation separately (H x V). Report contrast modulation data in the same format as Table 5.2-IV below.

**TABLE 5.2-IV.** Sample Reported Contrast Modulation Data

1-on/1-off Contrast Modulation (HxV):	
center	43 x 31%
average periphery	16 x 38%
worst location (@ 8:00)	6 x 46%
Resolvable Pixels (HxV) (screen average)	
@ $C_m = 25\%$	1412 x 1174
@ $C_m = 50\%$	1047 x 970

Worst location is defined as the test location on the screen where the minimum combined horizontal and vertical contrast modulation occurs. The combined contrast modulation is the magnitude calculated using square-root of the sum of the squares:

$$(H^2 + V^2)^{1/2},$$

where H is horizontal contrast modulation and V is vertical contrast modulation of white lines.

**Data:** Tabulate luminance spatial frequency and contrast modulation measurements at specified video input levels for each test location on the display screen.

**TABLE 5.2-V.** Sample Contrast Modulation Data

*n x n indicates repeating a grille pattern of lines n pixels wide sandwiching by n-pixel spaces (n Level-p/n Level-v).  
Input count level-100 set for commanding display to  $L_{max} = 685 \text{ cd/m}^2$ .  
Screen location - center*

<u>Large signal input</u>		$C_m(\text{out})/C_m(\text{in}), \%$		
% $L_{max}$ up from $L_{min}$	<u>Pin-to-Level-0 series</u>			
	Average Luminance (% of $L_{max}$ )	Spatial frequency, n x n		
		3 pixels	2 pixels	1 pixel
10	5	84	83	68
25	13	82	80	46
50	25	82	79	43
75	38	82	79	38
100	50	83	79	29
% $L_{max}$ down from $L_{max}$		<u>Pin-to-Level-100 series</u>		
		3 pixels	2 pixels	1 pixel
75	63	82	72	22
50	75	78	66	21
25	88	84	70	21
10	95	95	57	19

<u>Small signal input</u>		$C_m(\text{out})/C_m(\text{in}), \%$		
Average Luminance (% of $L_{max}$ )	Spatial frequency, n x n			
	3 pixels	2 pixels	1 pixel	
10	86	82	42	
25	90	75	30	
50	79	70	30	
75	90	75	30	
85	85	68	17	

A portion of these sample contrast modulation results are presented in the plots shown in Figures 5.2-10 through 5.2-13.

**Accuracy:** Contrast modulation results obtained by different laboratories agree to within 5%. Uncertainty of the contrast modulation measurement is 5%.

**Output:** See sample Figures 5.2-10 through 5.2-13.

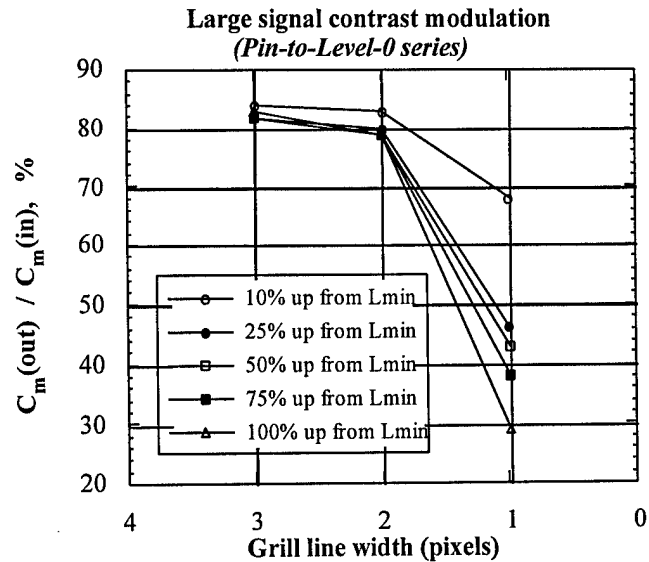

Sample Contrast Transfer Function (CTF) curves measured for large signal square-wave inputs to display grille patterns of equally spaced lines of widths ranging from 1 Level-p/ 1 Level-v pixels to 3 Level-p/ 3 Level-v pixels. The different curves represent various luminance levels for the Level-p pixel with the Level-v pixel pinned to Level-0 ( $L_{min}$ ).

**Figure 5.2-10**

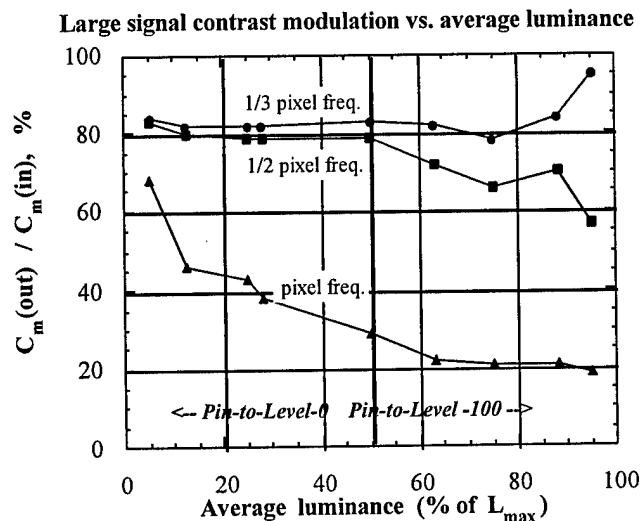

Sample curves of contrast modulation measured for large signal square-wave inputs as a function of the average luminance of the Level-v pixel and the Level-p pixels. The different curves represent grille patterns of equally spaced lines of widths ranging from 1 Level-p/ 1 Level-v pixels to 3 Level-p/ 3 Level-v pixels.

**Figure 5.2-11**

## Small signal contrast modulation with surround at Lmin

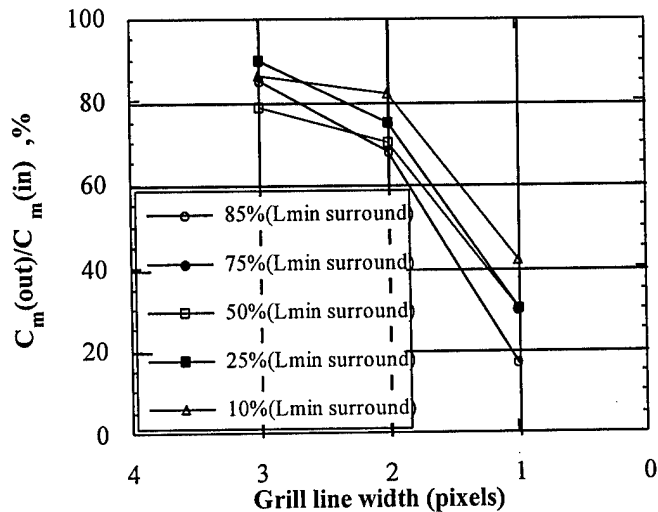

Sample curves of contrast modulation measured for small signal square-wave inputs to display grille patterns of equally spaced lines of widths ranging from 1 Level-p/ 1 Level-v pixels to 3 Level-p/ 3 Level-v pixels. The different curves represent various DC luminance levels about which the Level-v pixel is commanded to the DC luminance -5% of  $L_{max}$  and the Level-p pixel is commanded to the DC luminance +5% of  $L_{max}$ .

Figure 5.2-12

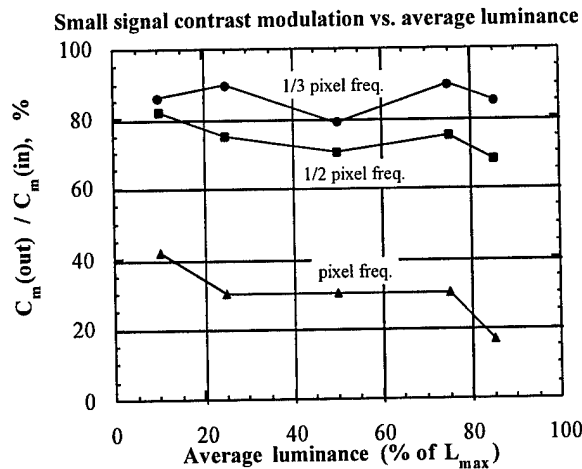

Sample curves of contrast modulation measured for small signal square-wave inputs as a function of DC luminance levels about which the Level-v pixel is set to the DC luminance -5% of  $L_{max}$  and the Level-p pixel is commanded to the DC luminance +5% of  $L_{max}$ . The different curves represent various grille patterns of

*equally spaced lines of widths ranging from 1 Level-p/ 1 Level-v pixels to 3 Level-p/ 3 Level-v pixels.*

**Figure 5.2-13**

This page intentionally left blank

## 6.0 GEOMETRIC CHARACTERIZATION

### 6.1 Waviness

**Objective:** Measure beam position on the CRT display to quantify effects of waviness which causes nonlinearities within small areas of the display distorting nominally straight features in images, characters, and symbols. The presence of waviness also causes large area raster distortions including pincushion, trapezoid (keystone), rotation and orthogonality.

**References:** Wojtowicz, *Utilization of Symmetry in CRT/Yoke Manufacture and Analysis*, SID'91 Digest, p.886.

ISO 9241 Part 3: Visual Displays, "Visual Display Terminals (VDTs) Used for Office Tasks - Ergonomic Requirements - Part 3: Visual Displays Final Text" as of June 1992.

IEEE Std. 202 -1954, *Measurement of Aspect Ratio and Geometric Distortion*.

ARP1782, *Photometric and Colorimetric Measurement Procedures for Airborne Direct View CRT Displays*, SAE, Jan. 1989.

VESA Standard: *Display Specifications and Test Procedures Version 1.0, Rev. 1.0*, 3 October 1994.

**Equipment:**

- Video generator
- Spatially calibrated CCD or photodiode array optic module
- Photometer
- Calibrated X-Y translation stage

**Test Pattern:** Use the three-line grille patterns in Figure 6.1-1 for vertical and horizontal lines each 1-pixel wide. Lines in test pattern are displayed at 100%  $L_{max}$  must be positioned along the top, bottom, and side edges of the addressable screen, as well as along both the vertical and horizontal centerlines (major and minor axes).

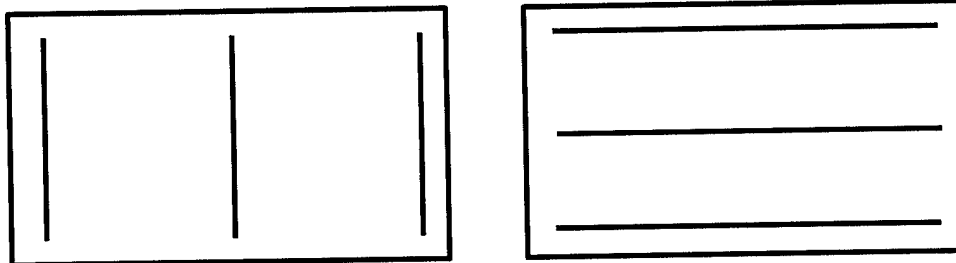

1-pixel-wide lines displayed at 100%  $L_{max}$

*Three-line grille test patterns.*

**Figure 6.1-1**

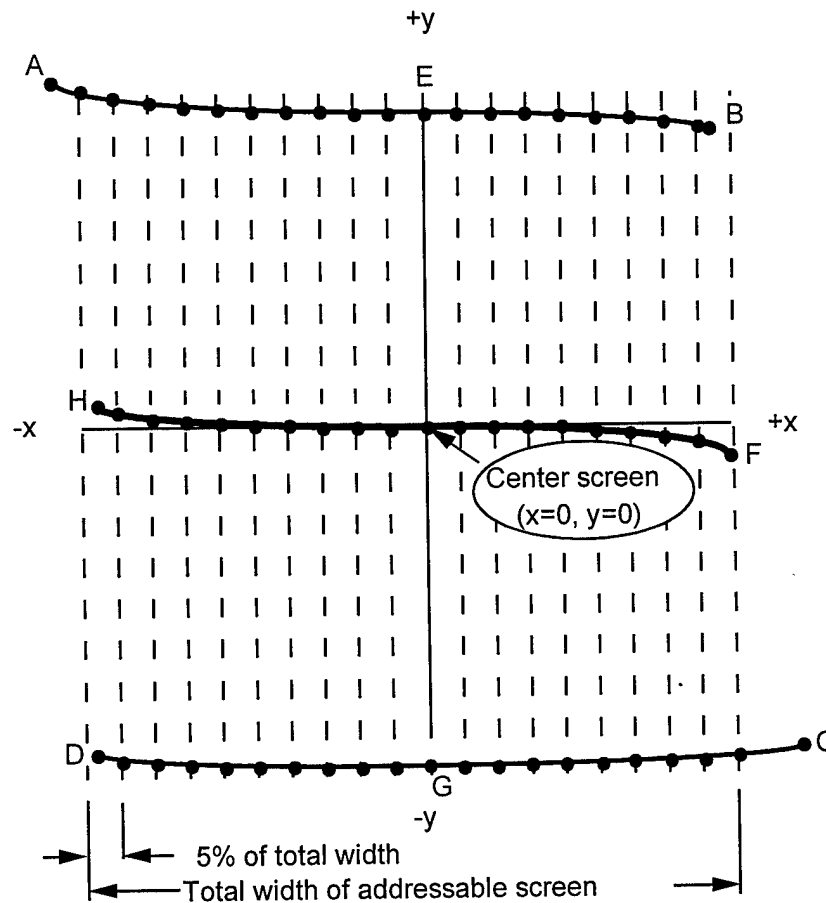

*Measurement locations for waviness along horizontal lines.  
Points A, B, C, D are extreme corner points of addressable screen.  
Points E, F, G, H are the endpoints of the axes.*

**Figure 6.1-2**

**Procedure:** Use diode optic module to locate center of line profiles in conjunction with calibrated X-Y translation to measure screen x,y coordinates along the length of a nominally straight line. Measure x,y coordinates at 5% addressable screen intervals along the line. Position vertical lines in video to land at each of three (3) horizontal screen locations for determining right-left waviness and pincushion, and vertical trapezoid. Similarly, position horizontal lines in video to land at each of three (3) vertical screen locations for determining top-bottom waviness and pincushion, and horizontal trapezoid.

**Data:** Tabulate deviations  $\Delta x, \Delta y$  positions at 5% addressable screen increments along nominally straight lines at top and bottom, left and right sides, and major and minor axes of the screen as shown in Table 6.1-I.

TABLE 6.1-I. Sample Data for Waviness

**Top/Bottom**      *Deviations (?y) from a nominally straight line as a function of x along the top and bottom of the screen (in mm).*

<u>Top</u>		<u>Bottom</u>	
<u>x</u>	<u>?y</u>	<u>x</u>	<u>?y</u>
-190.50	-1.143	-190.50	0.940
-177.80	-0.889	-177.80	0.635
-152.40	-0.533	-152.40	0.229
-127.00	-0.305	-127.00	-0.051
-101.60	-0.152	-101.60	-0.203
-76.20	-0.076	-76.20	-0.229
-50.80	-0.051	-50.80	-0.203
-25.40	-0.025	-25.40	-0.102
0.00	0.000	0.00	0.000
25.40	0.127	25.40	0.025
50.80	0.330	50.80	0.025
76.20	0.533	76.20	0.051
101.60	0.737	101.60	0.152
127.00	0.889	127.00	0.356
152.40	0.914	152.40	0.686
177.80	0.838	177.80	1.067
190.50	0.762	190.50	1.270

**Right/Left**      *Deviations (?x) from a nominally straight line as a function of y along the right and left sides of the screen (in mm).*

<u>Right</u>		<u>Left</u>	
<u>?x</u>	<u>y</u>	<u>?x</u>	<u>y</u>
-0.15	139.700	-0.13	139.700
-0.25	127.000	-0.03	127.000
-0.18	101.600	-0.10	101.600
-0.05	76.200	-0.13	76.200
0.03	50.800	-0.15	50.800
0.05	25.400	-0.23	25.400
0.00	0.000	0.00	0.000
0.00	-25.400	0.46	-25.400
0.10	-50.800	1.02	-50.800
0.18	-76.200	1.32	-76.200
0.25	-101.600	1.52	-101.600
0.36	-127.000	1.68	-127.000
0.41	-139.700	1.63	-139.700

TABLE 6.1-I. Sample Data for Waviness (cont'd)

**Major/Minor** *x,y positions (in mm) of nominally straight lines on the major and minor axes of screen.*

<u>Major</u>		<u>Minor</u>	
<u>X</u>	<u>Y</u>	<u>X</u>	<u>Y</u>
-190.50	0.203	0.05	139.700
-177.80	0.178	0.41	127.000
-152.40	0.076	0.23	101.600
-127.00	0.000	0.08	76.200
-101.60	0.051	-0.03	50.800
-76.20	0.076	-0.05	25.400
-50.80	0.076	0.00	0.000
-25.40	0.076	0.20	-25.400
0.00	0.000	0.48	-50.800
25.40	0.051	0.74	-76.200
50.80	0.127	0.99	-101.600
76.20	0.229	1.30	-127.000
101.60	0.356	1.45	-139.700
127.00	0.483		
152.40	0.610		
177.80	0.711		
190.50	0.787		

**Analysis:**

Waviness parameters are computed from the measured nonlinearities in the lines. Optionally, raster distortions may be quantified in conventional terms of north/south pincushion, east/west pincushion, vertical/horizontal trapezoid, rotation and orthogonality. Express north/south, top/bot, and vertical waviness amplitude as a percentage of total screen height. Similarly, express east/west, left/right, and horizontal waviness amplitude as a percentage of total screen width. Express rotation angles of grille lines in degrees, and express orthogonality as a percentage of total screen diagonal.

In Figure 6.1-2, points A, B, C, and D depict the extreme corners and points E, F, G, and H depict the ends of the axes. These corner and axes screen points are located by measured x,y coordinates (Ax, Ay) through (Hx, Hy). The center screen coordinates are (0, 0). Pincushion, trapezoid, and rotation (orthogonality) are calculated in the following way:

$$\text{Top pin} = \frac{0.5 (Ay + By) - Ey}{0.5 (AD + BC)} \times 100\%$$

where,  $AD + BC = Ay + By - Cy - Dy$

Similarly, calculate bottom pincushion using Cy, Dy, and Gy.

$$\text{Horizontal trapezoid} = \frac{AD - BC}{0.5 (AD + BC)} \times 100\%$$

$$\text{where, } AD - BC = (Ay - Dy) - (By - Cy)$$

Similarly, calculate vertical trapezoid using AB and CD.

$$\text{Rotation angle of major axis, Theta} = \text{Arc Tan } \frac{Fy - Hy}{Fx - Hx}$$

Similarly, calculate rotation angle of minor axis using (Ex,Ey) and (Gx,Gy).

$$\text{Orthogonality} = \frac{AC - BD}{0.5 (AC + BD)} \times 100\%$$

$$\text{where, } AC = [(Ax - Cx)^2 + (Ay - Cy)^2]^{1/2}$$

$$BD = [(Bx - Dx)^2 + (By - Dy)^2]^{1/2}$$

#### *Sample waviness calculations*

The waviness characteristic is determined by measuring the x,y positions of points along nominally straight lines across the screen. Waviness parameters are then computed from the measured nonlinearities in the lines. Sample data are presented in Table 6.1-II.

**TABLE 6.1-II.** Sample Waviness Data (in mm)

*Positions in table correspond to locations on display screen.*

Ax	Ay	Ex	Ey	Bx	By
-190.627	138.557	0.0508	139.7	190.3476	140.462
Hx	Hy	CTRx	CTRy	Fx	Fy
-190.5	0.2032	0	0	190.5	0.7874
Dx	Dy	Gx	Gy	Cx	Cy
-188.874	-138.76	1.4478	-139.7	190.9064	-138.43

*Waviness parameters calculated using above data:*

Top Pincushion	-0.07%
Horizontal Trap	-0.57%

Rotation, Major axis	0.09°
Orthogonality	0.12%

**Output:** Report maximum waviness as a percentage of linear screen dimension.

Waviness	= 0.4%
----------	--------

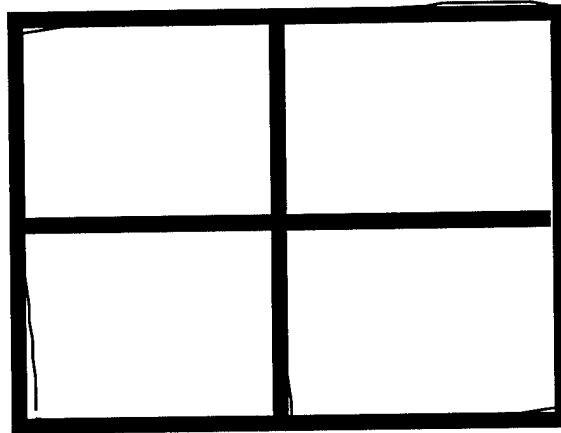

Grey bars are 1.27mm (50 mils) wide

*Sample plot of waviness data of Table 6.1-1.*

**Figure 6.1-3**

**Accuracy:** Accuracy of x,y translation stage should be better than 0.1% of display screen linear dimension for raster distortion (linearity, waviness) measurements. [ARP1782]

## 6.2 Linearity

**Objective:** Measure the relation between the actual position of a pixel on the screen and the commanded position to quantify effects of raster nonlinearity. Nonlinearity can be expressed as a variable pixel density. Nonlinearity of scan degrades the preservation of scale in images across the display.

**References:** ISO 9241 Part 3: Visual Displays, *Visual Display Terminals (VDTs) Used for Office Tasks - Ergonomic Requirements - Part 3: Visual Displays Final Text* as of June 1992.

IEEE Std. 202-1954, *Measurement of Aspect Ratio and Geometric Distortion*.

ARP1782, *Photometric and Colorimetric Measurement Procedures for Airborne Direct View CRT Displays*, SAE, Jan. 1989.

*VESA Standard: Display Specifications and Test Procedures Version 1.0, Rev. 1.0*, 3 October 1994.

**Equipment:**

- Video generator
- Spatially calibrated CCD or photodiode array optic module
- Photometer
- Calibrated X-Y translation stage

**Test Pattern:** Use grille patterns of single-pixel horizontal lines and single-pixel vertical lines displayed at 100%  $L_{max}$ . Lines are equally spaced in addressable pixels. Spacing must be constant and equal to 5% screen width and height to the nearest addressable pixel as shown in Figure 6.2-1.

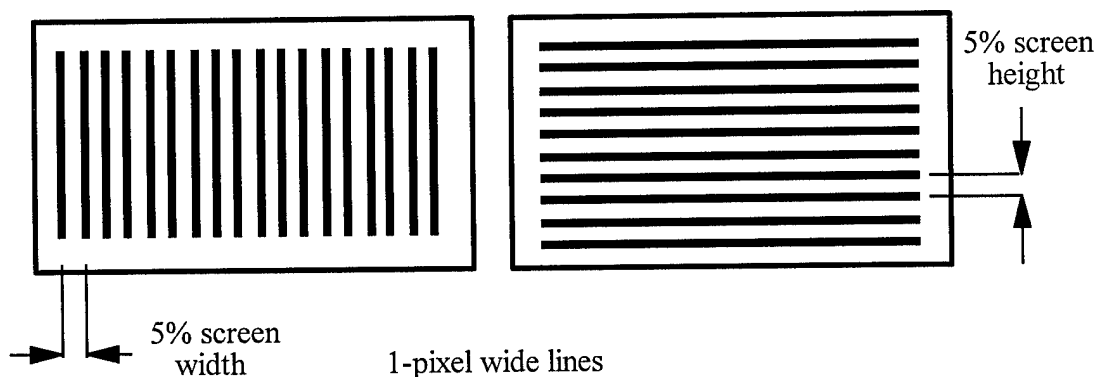

*V-grille for measuring horizontal linearity H-grille for measuring vertical linearity .*

**Figure 6.2-1**

**Procedure:** Use optic module to locate center of line profiles in conjunction with xy-translation stage to measure screen x,y coordinates of points where video pattern vertical lines intersect horizontal centerline of screen and where horizontal lines intersect vertical centerline of the CRT screen as shown in Figure 6.2-2.

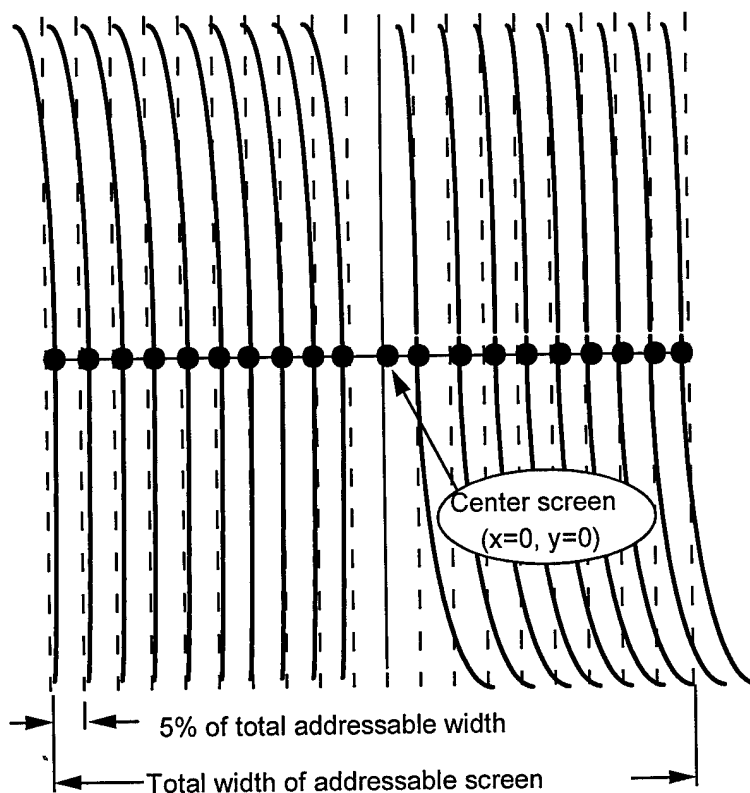

*Measurement locations for horizontal linearity along the major axis of the display. Equal pixel spacings between vertical lines in the grille pattern are indicated by the dotted lines. The number of pixels per space is nominally equivalent to 5% of the addressable screen size.*

**Figure 6.2-2**

**Data:** Tabulate x,y positions (in mm) of equally spaced lines (nominally 5% addressable screen apart) along major (horizontal centerline) and minor (vertical centerline) axes of the raster.

TABLE 6.2-I

Positions on axes (in mm) of equally spaced lines on screen. Luminance ~ 100% Lmax.

<u>x-Position, Vertical Lines</u>		<u>y-Position, Horizontal Lines</u>	
<u>Left Side</u>	<u>Right Side</u>	<u>Top</u>	<u>Bottom</u>
-189.713	18.212	140.437	-14.097
-170.434	36.322	126.492	-28.219
-151.333	54.483	112.624	-42.418
-132.029	72.949	98.704	-56.667
-112.700	91.719	84.658	-70.993
-93.447	110.795	70.536	-85.242
-74.371	130.124	56.363	-99.416
-55.499	149.809	42.215	-113.538
-36.830	169.774	28.118	-127.533
-18.339	190.068	14.046	-141.554

**Analysis:** Nonlinearity is the difference between the greatest and the least spacings measured between the lines. If both scans are truly linear, the differences in the positions of adjacent lines would be constant. The departures of these differences is the nonlinearity. Quantify vertical nonlinearity as a percentage of total screen height and horizontal nonlinearity as a percentage of total screen width.

The linearity of the horizontal raster scan is determined from measured x-positions of equally spaced vertical lines on the screen, such lines being equally spaced by pixel indexing. The linearity of the vertical scan is similarly determined using the y-positions of horizontal lines. First and second differences in x-positions of vertical lines are calculated to determine the horizontal non-linearity characteristic. Similarly, first and second differences in y-positions of horizontal lines are calculated to determine vertical non-linearity characteristic.

Deviations from linearity are determined as follows:

- Fit a straight line (measured screen position vs. pixel number) through the two data points on both sides of zero to define the pixel size (linear term) at the center of the screen and any zero offset between the measurement apparatus and the screen.
- Compute the nonlinearity by subtracting the computed position using the above linear fit from the measured data.
- Fit an equation with quadratic and cubic terms in pixel count to the residual for the right and left, and for the top and bottom. Separately fit the data for top, bottom, right, and left sides of the screen.

Absolute positions of vertical and horizontal lines are given in Table 6.2-I. Not only are nonlinearities present, but the degree of nonlinearity is

different top from bottom and right from left. This approach guarantees that the fitted equations will be continuous through the origin, as they should be. Sample results are shown graphically in Figures 6.2-3 and 6.2-4.

The maximum horizontal nonlinearity (referred to full screen size) is about 0.1% on the left and 0.5% on the right. The maximum vertical nonlinearity is about 0.8% on the top and 1.4% on the bottom.

The fitted equation is of the form:

$$\text{True Position} = a N + b N^2 + c N^3,$$

where  $N$  = pixel number.

and the coefficients obtained were:

	$a$	$b$	$c$
Left	0.23	-1.43E-5	-4.49E-9
Right	0.23	-4.76E-6	2.07E-8
Top	0.23	4.36E-6	-8.98E-9
Bottom	0.23	-9.81E-6	-1.31E-8

The local pixel size can be obtained by taking the derivative of the position equation giving:

$$\text{Local Pixel Size} = a + 2b N + 3c N^2$$

This curve is also shown in figures 6.2-3 and 6.2-4.

**Output:** Report maximum nonlinearity as a percentage of linear screen dimension.

Linearity	= 2.6%
-----------	--------

See sample linearity plots in Figures 6.2-3 and 6.2-4.

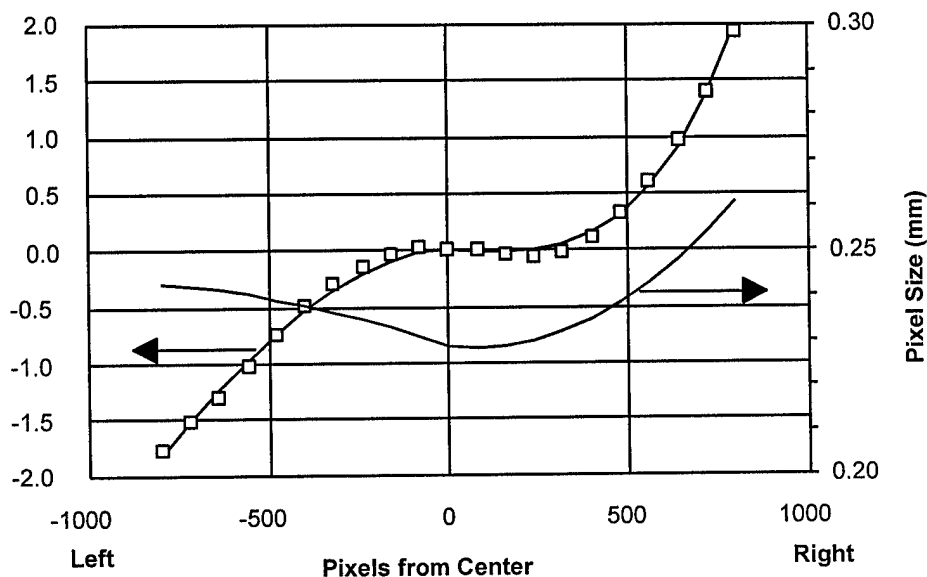

Sample horizontal linearity characteristics. The open boxes are measured data fitted with a cubic equation, shown by the line. The derived pixel size is also shown.

Figure 6.2-3

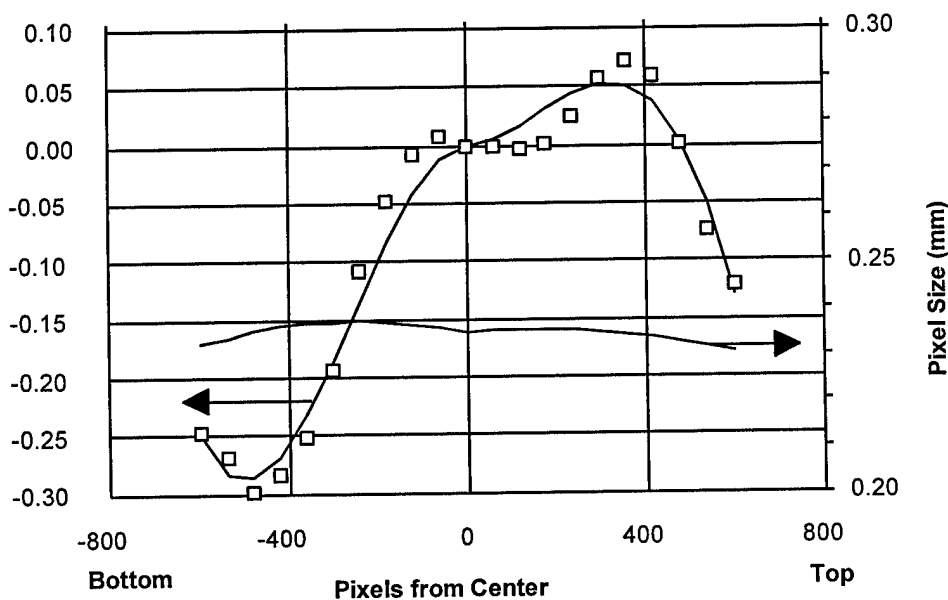

Sample vertical linearity characteristics. The open boxes are measured data fitted with a cubic equation, shown by the line. The derived pixel size is also shown.

Figure 6.2-4

**Accuracy:** Accuracy of x,y translation stage should be better than 0.1% of display screen linear dimension for raster distortion (linearity, waviness) measurements. [ARP1782] Linearity measurement results obtained by different laboratories agree to within 0.1% Uncertainty of the linearity measurement is 0.1%.

### 6.3 Raster Size Stability

**Objective:** Assess the stability of the high voltage supply by measuring the change of raster size as a function of the average luminance of the display. Since more current is required at higher luminance, the accelerating voltage will decrease, and thus the size of the raster will increase, if the power supply has less than perfect regulation.

**Equipment:**

- Video generator
- Spatially calibrated CCD or photodiode array optic module
- Calibrated X-Y translation stage
- Photometer

**References:** None

**Test Pattern:** Flat field pattern with visible edges shown in Figure 6.3-1.

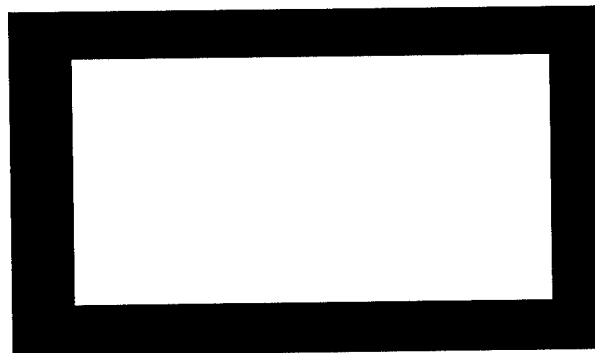

*Full Screen Flat field test pattern.*

**Figure 6.3-1**

**Procedure:** Along minor axis of screen, measure  $\varphi$  Y screen position of top and bottom edges of pattern as a function of luminance as the input count level is stepped up corresponding to 25%, 50%, 75% and 100%  $L_{\max}$  as determined in Section 3.0. Along major axis of screen, measure  $\varphi$  X screen position of right and left sides of pattern.

**Data:**

**TABLE 6.3-I.** Sample Data for Raster Size Stability

*Size of raster (in mm) as a function of screen luminance*

<u>% <math>L_{\max}</math></u>	<u>Width</u>	<u>Height</u>
100	383.819	286.588
75	383.870	286.715
50	384.099	286.791
25	384.175	286.842

**Analysis:** Quantify stability of raster size (in mm) as a function of screen luminance (in  $\text{cd}/\text{m}^2$ ).

**Output:** Report the maximum change in raster size as a percentage of the total screen linear dimension.

Raster Size Stability	= 0.1 %
-----------------------	---------

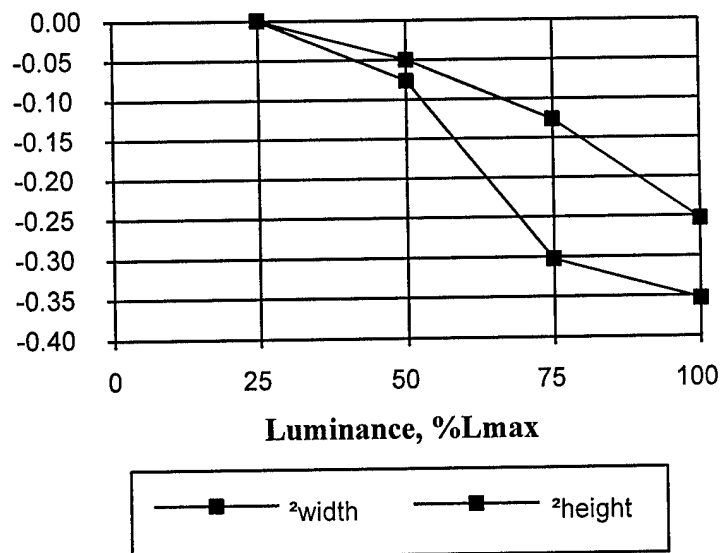

*Raster size stability as measured by the change in raster dimensions as a function of increasing luminance. The 25%  $L_{max}$  luminance level was used as a reference.*

**Figure 6.3-2**

**Accuracy:** Precision of x,y translation stage should be better than 0.1% of display screen linear dimension for raster distortion measurements. [ARP1782]

## 6.4 Scan Variability With Time: Jitter, Swim, Drift

**Objective:** Measure amplitude and frequency of variations in beam spot position of the CRT display. Quantify the effects of perceptible time varying raster distortions: jitter, swim, and drift. The perceptibility of changes in the position of an image depend upon the amplitude and frequency of the motions which can be caused by imprecise control electronics or external magnetic fields.

**References:** Ericksson, Sture, *Method of measuring jitter in VDUs*, DISPLAYS, Oct. 1989, pp. 207-209.

ISO 9241 Part 3: Visual Displays, *Visual Display Terminals (VDTs) Used for Office Tasks - Ergonomic Requirements - Part 3: Visual Displays Final Text* as of June 1992.

Beaton, R.J., and DeVilbiss, C.A., *Assessment method for the ANSI/HFS 100-1988 Guideline on Display Jitter*, SID 89 DIGEST, pp 216-219.

**Equipment:**

- Video generator
- Spatially calibrated CCD or photodiode array optic module
- Calibrated X-Y translation stage

**Test Pattern:** Use the three-line grille patterns in Figure 6.4-1 for vertical and horizontal lines each 1-pixel wide. Lines in test pattern must be positioned along the top, bottom, and side edges of the addressable screen, as well as along both the vertical and horizontal centerlines (major and minor axes).

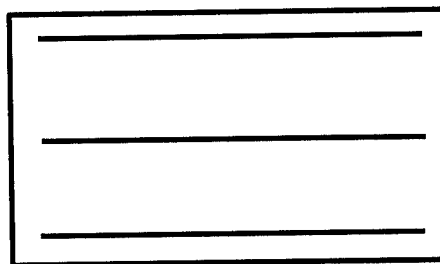
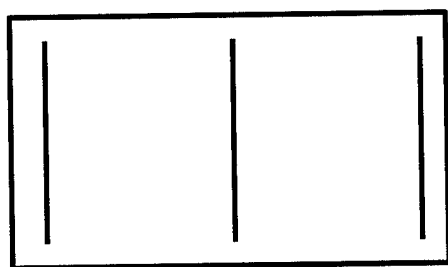

V-grille for measuring horizontal motion      H-grille for measuring vertical motion

1-pixel wide lines

*Three-line grille test patterns.*

**Figure 6.4-1**

**Procedure:** With the monitor set up for intended scanning rates, measure vertical and horizontal line jitter (0.01 to 2 seconds), swim (2 to 60 seconds) and drift (over 60 seconds) over a 2.5 minute duration as displayed using grille video test patterns. Generate a histogram of raster variance with time. The measurement interval must be equal to a single field period.

Optionally, define time periods for jitter, swim and drift as integer multiples of the monitor's frame period, as shown for examples in Table 6.4-I below:

**TABLE 6.4-I.** Time Periods for Jitter, Swim and Drift

Frame rate	Number of frames			Optionally, for multi- sync
	Jitter	Swim	Drift	
60 Hz	2	120	3600	
72 Hz	3	144	4320	
80 Hz	3	160	4800	

monitors measure jitter over the specified range of scanning rates. Some monitors running vertical scan rates other than AC line frequency may exhibit increased jitter.

Measure and report instrumentation motion by viewing Ronchi ruling or illuminated razor edge mounted to the top of the display. It may be necessary to mount both the optics and the monitor on a vibration damped surface to reduce vibrations.

**Data:** Tabulate motion as a function of time in x-direction at center and the four corner locations. Repeat for variance in y-direction at center and the four corner locations. Tabulate maximum and average motions (in mils) with display input count level corresponding to  $L_{max}$  (as determined in Section 3.0) for jitter (0.01 to 2 seconds), swim (2 to 60 seconds) and drift (over 60 seconds) over a 2.5 minute duration.

**Sample Data:****TABLE 6.4-II.** Sample Data for Scan Jitter

*Motions (in mils) at L<sub>max</sub> luminance.  
Time scales: Jitter 0.5 sec., Swim 10 sec., and Drift 60 sec.  
Instrumental motions less than 0.1 mil.*

<b>Maximum Motions</b>						
<b>Position</b>	<b>Vertical Motion</b>			<b>Horizontal Motion</b>		
	<b>Jitter</b>	<b>Swim</b>	<b>Drift</b>	<b>Jitter</b>	<b>Swim</b>	<b>Drift</b>
Center	3.5	3.8	4.0	1.2	1.3	1.3
2	5.0	5.5	6.2	4.1	4.9	4.9
4	5.1	6.3	6.4	8.0	9.6	9.9
8	4.3	5.0	5.4	5.8	7.5	7.5
10	4.2	4.5	4.6	5.1	5.9	5.9

<b>Average Motions</b>						
<b>Position</b>	<b>Vertical Motion</b>			<b>Horizontal Motion</b>		
	<b>Jitter</b>	<b>Swim</b>	<b>Drift</b>	<b>Jitter</b>	<b>Swim</b>	<b>Drift</b>
Center	2.3	3.2	3.7	0.7	1.0	1.2
2	3.2	4.8	5.8	2.8	4.	4.6
4	3.5	5.2	5.9	5.3	8.0	9.1
8	2.7	4.1	4.9	3.8	5.7	7.1
10	2.5	3.8	4.5	3.5	5.2	5.7

**Analysis:** Motions are most noticeable below 5 Hz and are perceived as degraded focus above 25 Hz. Quantify time variance in terms of maximum and average jitter, swim, and drift in horizontal and vertical directions of scan.

**Output:** Report the maximum jitter measured.

Jitter	< 0.13 mm (< 5 mils)
--------	----------------------

**Accuracy:** NIDL has reduced instrumentation vibrations to less than 0.2 mils by mounting optics and monitor on a vibration damped table.

## 7.0 REPORTING

**Objective:** A standardized performance certification report for each monitor type that enables users to:

- rapidly ascertain the monitor's performance capabilities
- easily compare the capabilities of different monitors
- judge the capability of the monitor for meeting their image-evaluation needs.

### SAMPLE EVALUATION DATASHEET

#### I. MANUFACTURER'S DATA

Manufacturer Name	Company ABC
Model #	1A
Monochrome or Color	Monochrome
Screen Diagonal	21 inches
Horizontal Scan Rate	89.71 kHz
Vertical Scan Rate	72.00 Hz
Image Size (H x V)	380.0 mm x 284.5 mm (14.96 x 11.20 inches)
Addressable Pixel Number	1600 x 1200
Pixel Size	0.237 x 0.237 mm (9.35 x 9.33 mils)
Dot or Stripe Pitch	0.28mm (11.0 mils)

#### II. MEASURED PERFORMANCES

##### A. Performance Related to Luminance

Warmup Time	20 minutes to $\pm 1\%$
Full Screen Luminance	103 $\text{cd/m}^2$ (30 fL)
Luminance Uniformity	76.67 - 96.13 $\text{cd/m}^2$
Color Coordinates	$x = 0.282, y = 0.295$
Color Uniformity	2.9% in x, 4.1% in y
System Gamma	2.45
Luminance Stability	$\pm 12\%$

##### B. Performances Related to Geometry

Waviness	$= 0.4\%$
Linearity	$= 2.6\%$
Raster Size Stability	$= 0.1\%$
Jitter	$< 0.13 \text{ mm } (< 5 \text{ mils})$

**C. Performance Related to Resolution**

50% Linewidth (HxV):		
center		0.328 x 0.287 mm (12.9 x 11.3 mils)
average periphery		0.340 x 0.284 mm (13.4 x 11.2 mils)
worst location (@ 10:00)		0.399 x 0.290 mm (15.7 x 11.4 mils)
Faceplate Reflectivity	specular	20%
	diffuse	3%
Contrast Ratio		75:1
Halation		= 5.6%
1-on/1-off Contrast Modulation (HxV):		
center		43 x 31%
average periphery		16 x 38%
worst location (@ 8:00)		6 x 46%
Resolvable Pixels (HxV) (screen average)		
@ C <sub>m</sub> = 25%		1412 x 1174
@ C <sub>m</sub> = 50%		1047 x 970

**D. Reliability and Life Performance**

MTBF	10,000 h
Cathode life at 100 cd/m <sup>2</sup> luminance	10,000 h

**E. Evaluator**

Organization Name	Testing Lab XYZ
Address	Tucson, AZ
Phone	( ) - - - - -
Evaluation Dates	3/1/93 to 4/1/93
Equipment Used	Photo Research PR-704, Microvision SS100

**F. Additional Performance Measurements Available: (Y X / N   )**

## REFERENCES

- ARP1782, *Photometric and Colorimetric Measurement Procedures for Airborne Direct View CRT Displays*, SAE, Jan. 1989.
- ASTM E1336 - 91, *Standard Test Method for Obtaining Colorimetric Data from a Video Display Unit by Spectroradiometry*.
- Beaton, R.J., and DeVilbiss, C.A., *Assessment method for the ANSI/HFS 100-1988 Guideline on Display Jitter*, SID 89 DIGEST, pp 216-219.
- Beaton and Farley, *Display Measurement Issues in the ANSI/HFS 100-1988 Standard*, SID'91 Digest, p. 648.
- Bechis, D. J., et al., *Display-Measurement Round-Robin*, SID 95 DIGEST, pp. 641 - 644.
- Briggs, S. J., *Soft Copy Display of Electro- Optical Imagery*, SPIE Vol. 762 Electro-Optical Imaging Systems Integration (1987), pp 153-170.
- CIE 38 *Radiometric and Photometric Characteristics of Materials and Their Measurement*, 1977.
- CIE 63, *The Spectroradiometric Measurement of Light Sources*, 1984.
- CIE No. 69, *Methods of Characterizing Illuminance Meters and Luminance Meters*, Publication, 1987.
- Ericksson, Sture, *Method of measuring jitter in VDUs*, DISPLAYS, Oct. 1989, pp. 207-209.
- Farrell, J.E., Benson, B.L., and Haynie, C.R., *Predicting Flicker Thresholds for Video Display Terminals*. Proceedings of the SID, 1987. 28(4): p. 449-453.
- Gindele, E.B., and Shaffer, S.L., *A Physical Optics CRT Faceplate Halation Model*, SID 90 Digest, p. 446 (1990).
- Gray, J. E., et al., *Acceptance and Use of the SMPTE Medical Diagnostic Imaging Test Pattern for Television Monitors and Hard-Copy recording Cameras*, SMPTE Journal, December 1990, pp. 1001-1007.
- IEEE Std. 202-1954, *Measurement of Aspect Ratio and Geometric Distortion..*

Infante, Carlo, et. al., *A 230MHz Bandwidth High-Resolution Monitor*, SID'83 Digest, pp. 124-125.

ISO 9241 Part 3: Visual Displays, *Visual Display Terminals (VDTs) Used for Office Tasks - Ergonomic Requirements - Part 3: Visual Displays Final Text* as of June 1992.

- ISO 9241 Part 7: Visual Displays, *Visual Display Terminals (VDTs) Used for Office Tasks - Ergonomic Requirements - Part 7: Display Requirements with Reflections Third Working Draft* Dec. 1991.
- ISO/TC159/SC4 N201 *Ergonomics requirements for office work with visual display terminals (VDTs). Part 8 Requirements for displayed colours*, Dec. 1990.
- Kane Jr., J. J., *Instrumentation for Monitor Calibration*, SMPTE Journal, Sept. 1990, pp. 744 - 752.
- Keller, Peter, *The EIA Standard for MTFs of Monochrome CRTs*, SID 89 DIGEST, pp. 204 - 207.
- Kelley, E. F., et al., *A Survey of the Components of Display-Measurement Standards*, SID 95 DIGEST, pp. 637 - 440.
- Miller, Ken, *Matching photometers to applications*, Information Display, 9/89, pp 7-9,18.
- MPR 1990:8 *Test Methods for Visual Display Units*, Swedish National Board for Measurement and Testing, Dec. 1990.
- Mullins, Mark, *How to Measure Signal Jitter*, Electronic Products, July 1992, pp 41-44.
- Olson, Thor, *Behind Gamma's Disguise*, SMPTE Journal, July 1995, pp 452 - 458.
- RS-343-A, *Electrical Performance Standards for High Resolution Monochrome Closed Circuit Television Camera*, EIA, Sept. 1969.
- SMPTE RP 133-1986, *Specifications for Medical Diagnostic Imaging Test Pattern for television Monitors and Hard-Copy Recording Cameras*, SMPTE, Jan. 1986.
- Tannas, Jr., Lawrence E., *Flat-Panel Displays and CRTs*, Van Nostrand Reinhold, NY, 1985.
- Tchen, H., et al., *Photocolorimetric Measurements of TV and HDTV Display Devices*, Application Notes, SID'92, pp. 75-78.
- TEB25, *A Survey of Data Display CRT Resolution Measurement Techniques*, EIA, 1985.
- TEB27, *Relating Display Resolution and Addressability*, EIA, 1988.
- TEPAC 105-81, *Industrial Cathode Ray Tube Test Methods*, EIA, Feb. 1981.
- TEP105-7-A, *Line Profile Measurements in Monochrome CRTs*, EIA, 1987.

TEPAC Publ.105-8, *Raster Response Measurement for Monochrome Cathode Ray Tubes*,  
EIA, Jan. 1987.

TEP105-9, *Line Profile Measurements in Shadowmask and Other Structured Screen  
CRTs*, EIA, 1987.

TEP105-10, *Contrast Measurement of CRTs*, EIA, 1987.

TEP105-11-A, *Measurement of the Color of CRT Screens*, EIA, Dec. 1988.

TEP105-12, *Test Method for Tube Face Reflectivity*, EIA, 1987.

TEP105-14, *Measurement of Phosphor Persistence of CRT Screens*, EIA, 1987.

TEP105-17, *MTF Test Method for Monochrome CRT Display Systems*, EIA, 1990.

TEP116-B, *Optical Characteristics of CRTs*, EIA, 1989.

Vandenberghe, P., et. al., *The Influence of CRT-Gamma on Luminance and Modulation*,  
SID 90 DIGEST, pp 152 - 155.

*VESA Standard: Display Specifications and Test Procedures Version 1.0, Rev. 1.0* ,  
3 October 1994.

Wojtowicz, *Utilization of Symmetry in CRT/Yoke Manufacture and Analysis*, SID'91  
Digest, p.886

This page intentionally left blank

## Appendix A

# DEFINITIONS OF MEASUREMENT TERMS AND ACRONYMS

<b>Addressability</b>	The inter-pixel distance [TEP 192]. Defines how precisely one can position the electron beam spot on the screen.
<b>AFGS</b>	Air Force Guide Specification
<b>ARP</b>	Aerospace Recommended Practice, associated with SAE
<b>ASTM</b>	American Society for Testing and Materials
<b>Candelas per square meter (cd/m<sup>2</sup>)</b>	Metric unit of measurement of luminance. 1 cd/m <sup>2</sup> = 0.2919 Footlambert (fL).
<b>CIE</b>	Commission Internationale De l'Eclairage (International Commission on Illumination)
<b>Contrast Modulation, (C<sub>m</sub>)</b>	Measure of the luminance ratio between the lit and unlit portions of grille patterns. A grille pattern of given frequency is considered to be resolved when the contrast modulation is greater than 20%.
<b>CRT</b>	Cathode Ray Tube
<b>Contrast Transfer Function, (CTF)</b>	Curve of contrast modulation values plotted as a function of spatial frequency.
<b>EIA</b>	Electronic Industries Association
<b>Fill Factor</b>	The ratio of lit to total active area of a display screen.
<b>High Voltage Regulation</b>	Measure of variation of overall raster size with changes in luminance (as caused by changes in electron beam current). High voltage output from a well regulated supply will not change with beam current.

**ISO**

International Standards Organization

**Linearity**

Measure of the preservation of the scale of image contents across the screen.

**Luminance Stability vs. Fill Factor**

Measure of variation in luminance as a function of the fraction of screen area that is being lit (i.e., the fraction of the frame time in which the electron beam is actually turned on).

<b>MPR</b>	[Swedish] National Board for Measurement and Testing
<b>NIDL</b>	National Information Display Laboratory
<b>NIST</b>	National Institute of Standards and Technology, formerly NBS
<b>NBS</b>	National Bureau of Standards
<b>Pixel</b>	Picture Element
<b>Resolution</b>	Measure of the ability to discriminate picture detail; i.e., ability to distinguish two adjacent spots on the screen.
<b>RS</b>	Recommended Standard published by EIA
<b>SAE</b>	Society of Automotive Engineers
<b>Scan Jitter</b>	Rapid motions of raster on the screen face caused by instabilities in the monitor circuitry.
<b>SID</b>	Society for Information Display
<b>Spatial Uniformity of Luminance</b>	
	Measure of how luminance varies across the screen. Luminance should be as uniform as possible.
<b>SWEDAC</b>	Swedish Board for Technical Accreditation, formerly MPR
<b>System Gamma</b>	The slope of the curve in a log-log plot of output luminance vs. input drive.
<b>TEB</b>	TEPAC Engineering Bulletin published by EIA
<b>TEPAC</b>	Tube Engineering Panel Advisory Council associated with the EIA.
<b>TBD</b>	To be determined

**Warmup Characteristic** Time required for the luminance to stabilize at some predetermined value; e.g.  $\pm 1\%$

**Waviness** Measure of the degree of curvature of (or departure from) nominally straight lines on the display screen. Principle components of waviness are:

- Pincushion - a quadratic distortion
- Gullwing - a quartic distortion.

## Appendix B

### SCREEN TEST POINTS FOR MONOCHROME CRTS

The number and location of monochrome CRT screen test point locations depends on the performance parameter being evaluated, the size of the display screen, and the intended use of the display. This appendix is intended to provide guidance for the use of alternative test points when appropriate.

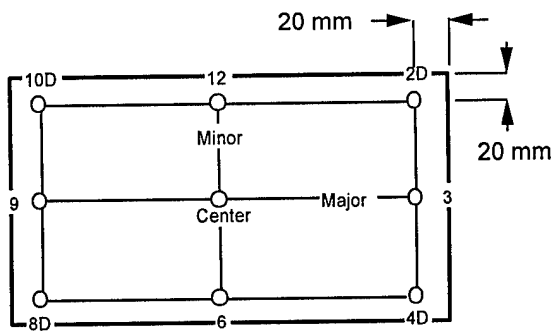

**Figure B-1.** Locations of nine screen test points for measuring resolution, luminance and white point, and conventional raster distortion parameters on a monochrome CRT.

#### *Considerations for CRT displays*

CRT performance typically is best at screen center and degrades towards the periphery. Further, CRT performance in the corner screen locations is generally worse than the performance along the major and minor axes of the screen. Also, CRTs exhibit significant asymmetries in performance errors due to manufacturing and setup; therefore, a complete

evaluation of a given performance parameter requires measurements be taken in each of the four quadrants of the CRT screen so that the contributions of each of the asymmetrical parts are taken into account.

#### *Contrast modulation and luminance uniformity measurements*

Use five screen points located at screen center and four corners, minimum. On the typical monochrome CRT, center and corner locations exhibit the best and worst resolution, respectively. Measurements at all four corners are required to distinguish asymmetrical properties of the display. Preferably include four additional measurement points located at both ends of major and minor axes of the screen. Typical screen points are located at mechanical center and 20 mm inward from the viewable edges of the screen as depicted in Figure B-1. When using alternative screen locations, consider that for the typical CRT, contrast modulation is a function of beam spot size and degrades between screen center and the periphery.

#### *Linearity measurements*

Non-linearities in CRT displays are assessed by measuring the separate contributions of the horizontal and vertical deflection along the major and minor axes, respectively, of the CRT screen. Measurement intervals along the axes should be equal to 5% of either the total height or total width of the screen, whichever is larger. Preferably, for

screens with long dimensions greater than 20 inches, use 1-inch measurement intervals across the screen to characterize the non-linearity.

#### *Waviness measurements*

Preferably measure waviness along displayed lines at top, bottom, both axes, and both sides of the CRT screen using measurement intervals equal to 5% of either the total height or total width of the screen, whichever is larger. For

screens with long dimensions greater than 20 inches use 1-inch intervals across the screen.

Minimally, conventional raster distortion parameters: pincushion, trapezoid, orthogonality and rotation, can be evaluated by measuring only the x,y positions of the four corners and both ends of each of the major and minor axes of the active raster.

### Comparison with ISO 9241 Part 3 CRT screen measurement locations

The comparison between NIDL and ISO specified positions of display screen test locations depends on CRT size and on the particular performance parameter being measured. As depicted in Figure B-2, NIDL corner locations are defined for all sizes of CRTs to be a fixed distance of 20mm inside the edges of the addressable screen for all performance measures. In terms of screen diagonal (D), NIDL

corner test points are located 1.11 inches inward or  $D-1.11$  inches. By comparison, there are two definitions for ISO corner locations. Corner points for square rasters, for example, are implied to be located at  $D-0.0566D$  for area luminance measurements, and are stated to be located at  $D-0.1D$  for spatial resolution and contrast modulation measurements.

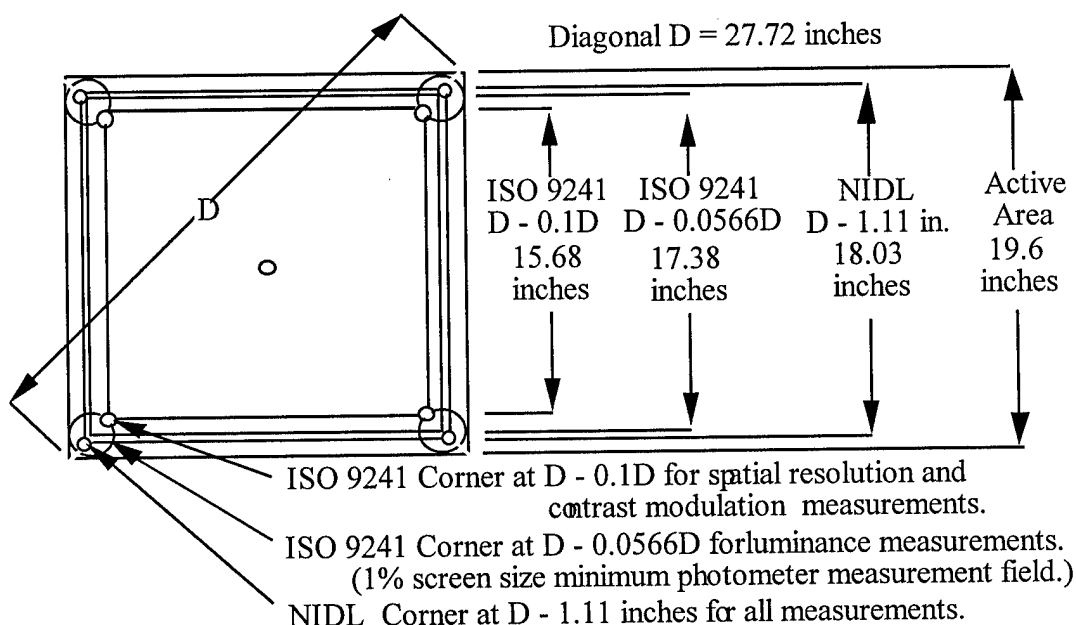

**Figure B-2.** Test point locations as specified by NIDL and ISO 9241 as applied to a 20-inch x 20-inch CRT.

- *ISO 9241 Part 3 test points for luminance measurements*

ISO 9241 specifies the use of screen test locations for luminance measurements which are limited by their requirement that the photometer measurement field be at least 1% of the total active area of the addressable screen. For square rasters, for example, corner test points along the diagonals would have to be located inward from the extreme addressable corner by at least  $0.0566D$ . NIDL CRT screen test locations for luminance measurements are more severe than ISO 9241 locations for CRTs larger than 20-inch diagonal (20V) as shown graphically in Figure B-3.

- *ISO 9241 Part 3 test points for resolution measurements*

For spatial resolution and contrast modulation measurements, ISO 9241 specifies the use of standard screen test locations with corner test points along the diagonals which are located inward from the extreme corner by  $0.1D$ . NIDL CRT screen test locations are more

severe than these ISO specified locations for CRTs larger than 11-inch diagonal (11V) as shown graphically in Figure B-3.

- *Impact of photometer measurement field size on screen test point locations*

The NIDL luminance measurement and the ISO area average luminance measurement both use the same target, a full flat field. The two procedures differ only by the size of the area over which the luminance is integrated (photometer measurement field).

ISO specifies a minimum area measurement field of at least 1% of the active screen while the NIDL procedure specifies a minimum size of 10 scanning lines for the photometer measurement field. An implication of using the NIDL test point locations is that the maximum size of the photometer measurement field is limited to a maximum diameter of 40mm, approximately 1% of a 20-inch diagonal active screen.

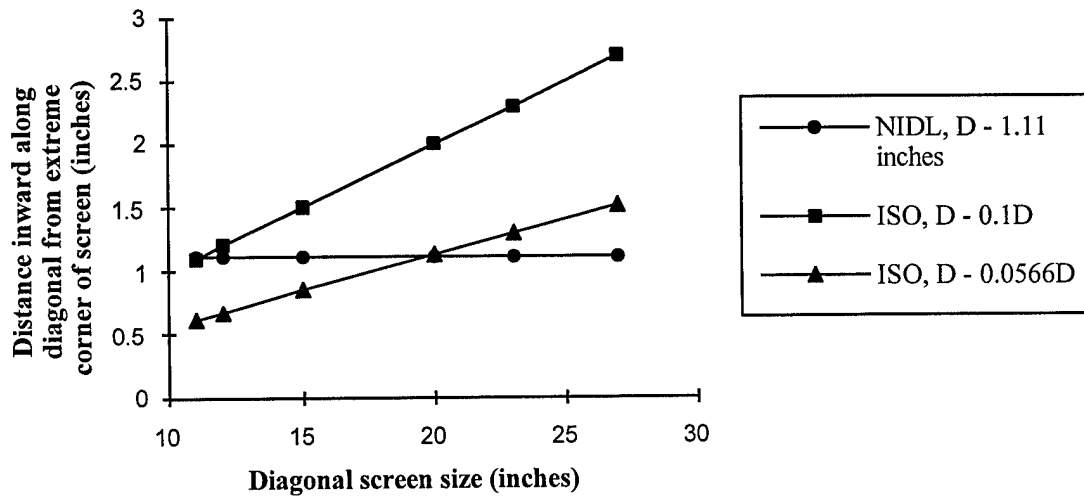

**Figure B-3.** Location of NIDL and ISO 9241 corner screen test points for CRT displays. Since ISO locations are proportional to screen size, they are less severe than NIDL locations for large-screen CRTs.

So for 20V tubes, NIDL and ISO area average luminance measurements are equivalent. But, for typical CRTs of equal deflection angle with screens larger than 20V, the corner screen luminance values and center-to-corner luminance uniformity ratios will be worse using the more severe NIDL criteria compared to ISO for two reasons:

- (1) the NIDL maximum 40mm diameter measurement field covers an increasingly smaller percentage of the total screen area which increases the corner-to-center differential in measured luminance, and
- (2) the deflection angle to reach the NIDL corner measurement point continues to increase with screen size, resulting in increasingly lower corner screen luminances relative to screen center.

• *Waviness*

The NIDL waviness procedure specifies either 5% screen size or 1-inch measurement intervals (whichever is smaller) offering a practical alternative to the character-size (120-mils) measurement interval implied by ISO 9241 Part 3.

ISO 9241 Part 3 Section 6.13 Linearity specifies non-linearities including pincushion and gullwing distortions to be measured using rows and columns of characters implying a measurement interval of 120 mils. The narrow stroke width of characters and the discontinuity caused by blank spaces between characters adds unnecessary uncertainty and difficulty to the waviness measurement.

ISO waviness performance guidelines state that adjacent characters should be aligned to within 5% of the height or width of the character. Character height, for example, as specified in ISO section 6.4 should subtend a visual angle of 16 to 22 minutes of arc at the intended viewing distance. Section 6.1 specifies a minimum viewing distance of at least 400mm. Using these criteria, the character height is 2.6 mm (100 mils) assuming 20 minutes of arc per character at 400mm (15.75 inches) viewing distance. Therefore, the 5% character-to-character waviness limit is 5 mils. One-pixel minimum character spacing is specified in ISO Section 6.10. The implication, then, is that, the ISO test pattern for measuring waviness consists of rows and columns of 100-mil text characters spaced apart by as little as one pixel (10 to 20 mils per pixel).

To test this approach, a waviness measurement experiment was performed on a 20-inch x 20-inch CRT monitor. Figure B-4 is an x,y-scatter plot showing the location of points along a vertical line which were measured at 120-mil (character-size) intervals. For this data, the average change in position of the line (waviness) can be approximated by measuring the position of the line at 1-inch intervals and then dividing by the number of characters that fit within one measurement interval (8.3 characters per inch in this case) .

• *Linearity*

ISO 9241 Part 3 Section 6.9 Character size uniformity specifies character size variation across the display screen (scan non-linearities) shall be less than 5% of the character height or approximately 5

mils for a 100-mil character. This implies measuring the positions of characters displayed in rows and columns with a measurement interval of 120 mils. The same measurement difficulties related to using test patterns composed of single-stroke characters arranged in rows and columns separated by one-pixel spacings described above for evaluating waviness equally apply to the measurement of

linearity. NIDL proposes using alternate test patterns for measuring horizontal and vertical linearity consisting of nominally equally spaced vertical and horizontal lines, respectively. The nominal spacing is the smaller of 5% screen size or 1-inch, thus reducing the number of measurements compared to measuring the positions of characters.

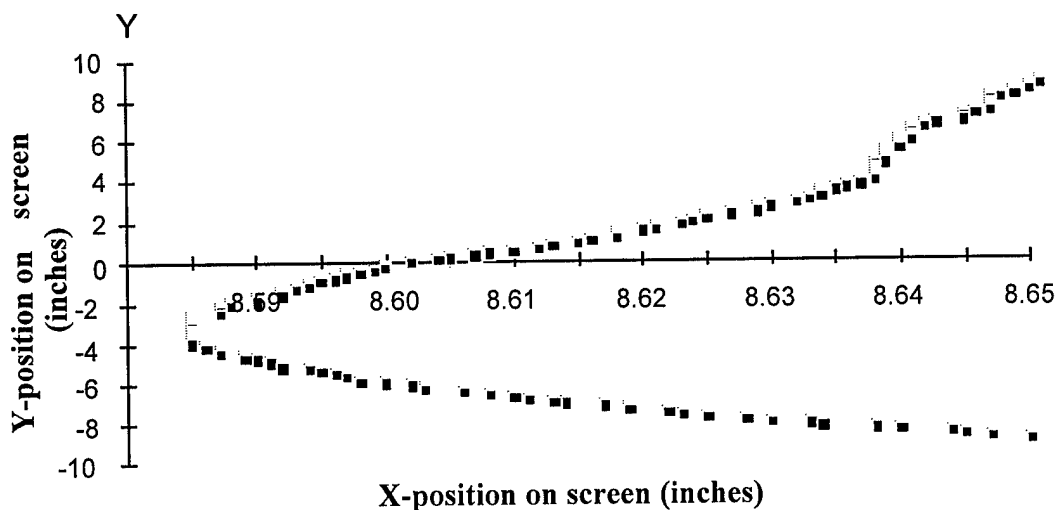

**Figure B-4.** Waviness measurement results are plotted showing locations of x,y-points measured along a vertical line displayed on the right side of a 20-inch x 20-inch CRT screen. The x-position of adjacent data points are spaced less than 4-mils apart. Experimental results indicate a measurement interval of 1 inch yielded sufficient data to predict maximum waviness to within 4.6 mils of that calculated using data measured every 120 mils along the same vertical line. Using 1-inch measurement intervals instead of character-size (120-mils) intervals reduces the number of measurement points along a single line on a 20-inch x 20-inch CRT from 138 to just 18 points.

This page intentionally left blank

## Appendix C

# DETERMINATION OF FLICKER PERCEPTIBILITY

**Objective:** Determine analytically whether the display will appear flicker-free to 90% of the user population.

**References:** ISO 9241 Part 3: Visual Displays," *Visual Display Terminals (VDTs) Used for Office Tasks - Ergonomic Requirements - Part 3: Visual Displays Final Text*" as of June 1992.

Farrell, J.E., Benson, B.L., and Haynie, C.R., *Predicting Flicker Thresholds for Video Display Terminals*. Proceedings of the SID, 1987. 28(4): p. 449-453.

TEP105-12, *Test Method for Tube Face Reflectivity*, EIA, 1987.

TEP105-14, *Measurement of Phosphor Persistence of CRT Screens*, EIA, 1987.

*VESA Standard: Display Specifications and Test Procedures Version 1.0, Rev. 1.0*, 3 October 1994.

**Equipment:** Photometer

**Test pattern:** Flat field pattern as shown in Figure C-1.

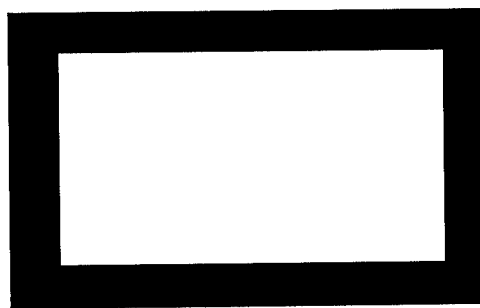

*Flat field test pattern*

**Figure C-1**

**Procedure:** Use display size, phosphor persistence, refresh frequency, and luminance of the display to predict the degree of flicker. Use the method presented in ISO 9241 Part 3 *Informative Annex A. Analytical techniques for*

*predicting screen flicker.* This method is summarized below for convenience.

1. Measure the display luminance  $L_t$  in  $\text{cd}/\text{m}^2$ .
2. Turn off the display and measure the reflected luminance  $L_r$  in  $\text{cd}/\text{m}^2$  due to ambient lighting.
3. Calculate pupil diameter  $d$  in mm:  $d = 5 - 3 \tanh(0.4 \times \log(3.183 L_t))$
4. Calculate the DC component of temporally varying retinal illuminance in trolands:

$$\text{DC} = (L_t - L_r) A$$

$$\text{where } A = p(d/2)^2, \text{ area of pupil in } \text{mm}^2$$

5. Calculate the amplitude coefficient using the exponential time constant  $a$  describing the persistence of the phosphor, and the refresh frequency  $f$  of the display:

$$\text{Amp}(f) = 2 / [1 + (2 p a f)^2]^{1/2}$$

Time constant  $a$  may be calculated from the phosphor decay time  $\text{TC}_{10\%}$  using:

$$a = 0.4343 \times \text{TC}_{10\%}$$

( $\text{TC}_{10\%}$  is the time it takes for the phosphor luminance to decay to 10% of the peak luminance after electron excitation has been removed.)

6. Calculate the luminance modulation  $E_{\text{obs}}$  in trolands:

$$E_{\text{obs}} = \text{DC} \times \text{Amp}(f)$$

7. Calculate the energy  $E_{\text{pred}}$  in trolands perceived as flicker using values for constants  $a$  and  $b$  given in Table C-I.

$$E_{\text{pred}} = a e^{bf}$$

8. The display is flicker free when  $E_{\text{obs}} < E_{\text{pred}}$ .

**Table C-I.** Flicker parameters for various screen sizes (from ISO 9241 Part 3).

Size (degrees of visual angle)	CFF = $m + n \times \ln(E_{\text{obs}})$		$E_{\text{pred}} = a e^{bf}$	
	<u>m</u>	<u>n</u>	<u>a</u>	<u>b</u>

10°	14.6	6.999	0.1276	0.1424
30°	13.8376	8.31	0.1919	0.1201
50°	8.31	9.73	0.5076	0.1004
70°	6.783	10.034	0.53	0.0992

Size (degrees of visual angle) =  $2 \times \tan^{-1}(D/2V)$

where, D = screen diagonal and V = viewing distance

9. The screen is deemed flicker free when refresh frequency > CFF.  
Alternatively, calculate the critical flicker frequency CFF in Hz:

$$\text{CFF} = m + n \times \ln(E_{\text{obs}})$$

**Analysis:** The plot in Figure C-2 is intended to illustrate the impact of display size and luminance on the critical flicker frequency. [Farrell, et al.]

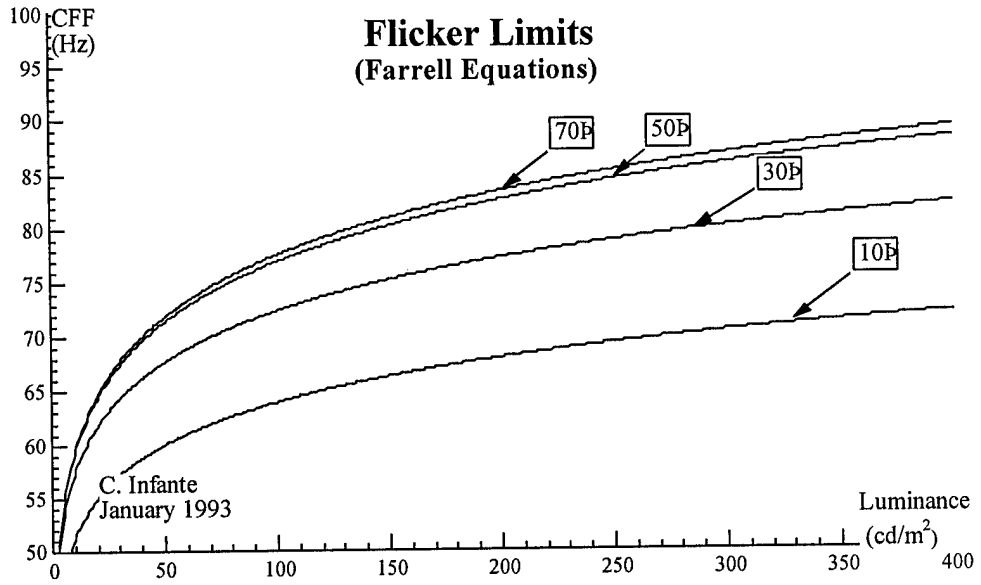

*Plot of critical flicker frequency versus display luminance for various display sizes specified in degrees of visual angle.*

**Figure C-2.**

This page intentionally left blank

INTERNET DOCUMENT INFORMATION FORM

**A . Report Title: Display Monitor Measurement Methods under Discussion by EIA (Electronic Industries Association) Committee JT-20, Part 1: Monochrome CRT Monitor Performance, Version 2.0**

**B. DATE Report Downloaded From the Internet: 21 Sep 98**

**C. Report's Point of Contact: (Name, Organization, Address, Office Symbol, & Ph #:) National Information Display Laboratory  
Princeton, NJ**

**D. Currently Applicable Classification Level: Unclassified**

**E. Distribution Statement A: Approved for Public Release**

**F. The foregoing information was compiled and provided by: DTIC-OCA, Initials: \_\_JR\_\_ Preparation Date: 21 Sep 98**

The foregoing information should exactly correspond to the Title, Report Number, and the Date on the accompanying report document. If there are mismatches, or other questions, contact the above OCA Representative for resolution.