

# FINAL REPORT

## Bulk Gallium Nitride Growth

N00014-97-1-0863

05/30/97 - 05/30/98

Stanford University

J. S. Harris  
Principal Investigator

19980921 100

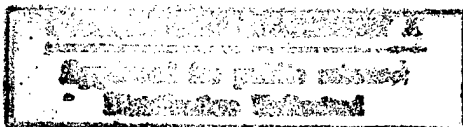

## Bulk Gallium Nitride Growth

J. S. Harris and Jun Liu

Department of Electrical Engineering, Stanford University, CA 94303-4075

Gallium Nitride (GaN), a direct bandgap semiconductor, has a room temperature energy gap ( $E_g$ ) of 3.39 eV. It forms a completely miscible solution with In (which decreases  $E_g$ ) and Al (which increases  $E_g$ ). Thus, light output wavelength can be tuned via bandgap engineering or via the introduction of appropriate impurities to form luminescent color centers. In principle, LEDs and lasers spanning the entire visible spectrum can be fabricated with (Ga-In-Al)N system.

Application of the III-N semiconductor LEDs include:

- The first electronically controlled airplanes, ships and tanks. With less need for hydraulics and air conditioning, they'd be lighter, more reliable and cheaper to run and maintain.
- Digital Versatile Disc (DVD), coupled with blue laser technique, can store about 48 GB, 14 times more information than current CDs can. Within several years, recordable DVD-RAM and DVD-ROM discs and players should be in market place.
- Tiny sensors that operate in harsh environments, such as smokestacks, tailpipes, power plants, and especially drilling in petroleum industry. They could detect pollutants or tell operators how to adjust an engine to get the cleanest, most efficient burn. Blue light also has application for spectrographic detection, ranging from medical applications to analyze blood or monitor for oxygen levels, to using blue light sensors to sniff out biological and toxic agents both on and off the battlefield.
- Full-color video billboards that dazzle even in daylight, the LED-based flat panel computer and television displays could be brighter and more energy efficient than the current liquid crystal display devices.
- Light source: LED will be "the ultimate lamp," which would burn for 10 years straight, with much greater efficiency, eventually supplanting incandescent bulbs. Switching from the light bulb to LED reduces energy consumption by more than 85%, which would approach \$35 billion per year in the US households, if applied.

A review of semiconductor technology reveals that there is NO technologically important application of materials to electronic and optoelectronic devices that do not have a good substrate as the base upon which to build increasingly complex devices and circuits. Researchers struggled for years, for example, to grow high quality GaAs on Si substrates, and eventually realized it is impossible to reduce dislocation densities below  $10^5$ - $10^6$ cm<sup>-2</sup> due to the 4% lattice mismatch between GaAs and Si. Ideally, one would like to grow materials on like substrates, thereby assuring lattice matching. There is currently no available native GaN substrate or even non-native lattice matched substrate for GaN or related III-V nitrides. Growth of layers on different substrates such as sapphire, ZnO and MgO results in lattice mismatch, and stack faulting, which caused device failure. Sapphire, a popular substrate in epitaxial growth of GaN, for example, has a 16% lattice mismatch with GaN, yielding dislocation densities as high as  $10^9$ - $10^{10}$ cm<sup>-2</sup>. The development of high-power electronics and optoelectronics based on GaN requires a dramatic reduction in the epitaxial material defect density, which is best achieved through the use of a native substrate. In spite of the outstanding results of Shuji Nakamura of Nichia and many other

recent remarkable gains in GaN based epitaxial crystal growth, there is a consensus that a better substrate material could improve material quality, device reliability and manufacturing.

Special thermal properties of GaN posed great difficulty in its single crystal growth:

- (1) high melting point: the melting point of GaN is estimated to be over 2200° C. It is a great challenge for crystal growers to even find out appropriate crucible and muffle materials;
- (2) incongruent melting: GaN will decompose at temperature above 1200° C, at 1 atmosphere, to Ga metal and N<sub>2</sub>, before reaching its melting point. Conventional crystal growth methods, developed at 1 atmosphere, therefore, cannot apply to GaN growth.

Stanford University has leveraged a broad range of unique and excellent high-pressure, high-temperature furnaces in the Department of Geological and Environmental Sciences and US Geological Survey at Menlo Park to develop a bulk growth GaN, InN and InGaN technology.

### **Experimental setting:**

high-pressure piston-cylinder presses:

All experiments were conducted by using four high pressure piston-cylinder facilities at USGS high pressure laboratory, which has excellent equipment and expertise in high-pressure crystal growth. Piston-cylinder press consists of a simple piston and a cylinder ( Fig. 1). Homogeneous pressure is generated by hydraulic ram forcing a piston into a cylinder and compressing the solid materials in the furnace assembly (Fig. 2a). Temperature is generated by passing a very high current through the graphite tube furnace which is inside the vessel. The pressure range is 5000-60000 atm, with precision and accuracy being  $\pm 200$  atm, and our experiments were conducted at 10000-20000 atm; the temperature range is up to 1800 °C, measured by Pt-Pt<sub>90</sub>Rh<sub>10</sub> thermocouple, with precision and accuracy being  $\pm 5$  °C, respectively. Experiments were conducted at 500-1350 °C. Sample volume is 0.1-0.3 ml. The volume is limited by a container size, the larger diameter Pt tubes being very costly, we carried out reconnaissance experiments by using platinum capsules with 4 mm inside diameter (i.d.), and 10 mm length, after finding out the optimum experimental conditions, we used 1/4" (6.4 mm) i.d., 1/2" (12.8 mm) length Pt capsules to ensure larger space for the growth of GaN single crystal. Four types of furnace assembly (Fig. 2a, 2b, 2c, and 2d) have been used. Fig. 2a is designed for minimum friction, but has an upper T limit of 1000 to 1100 °C. At higher T, the NaCl parts melt and the graphite furnace disintegrate which will cause experiment fail. Fig. 2b is a new design, the BaCO<sub>3</sub> parts can sustain much higher temperature, but the furnace deforms about 1/4 length when compressed which often causes Pt capsules leak. The furnace assembly in Fig. 2c consists of NaCl parts and fused silica tube and rod, which keeps the graphite furnace integrate when NaCl melts. This new design is very stable at T up to 1700 °C, P 10000-30000 atm. To prevent metallic starting materials such as Ga, In, or some flux such as Sn, forming alloy with precious metal containers, we have designed a double capsule technique (Fig. 2d), with BN as the inner capsule, and Pt as outer capsule, and when Pt capsule was welded, it can maintain higher partial pressure of N than equilibrium pressure so that reaction move toward GaN.

### **Experimental methods and results:**

(1) Sublimation-condensation: In this method, nitride powders were sintered, and recrystallized at high temperature, high pressure. because only in rare cases does the experimental temperature exceed the melting temperature of nitrides, experimental products were polycrystalline nitrides. Polish scientists (Porowski and his colleges) used this method, conducting experiments at 1200-1600 °C, 12000-20000 atm in GaN-N<sub>2</sub> or Ga-N<sub>2</sub> systems, they have obtained platelet and needle polycrystalline GaN, with the largest grain of GaN from 1 mm in 1995 to 6-7 mm in 1997. Sack (1998) of Rensselaer Polytechnic Institute have grown 7 mm diameter and 12 mm length AlN single crystal in tungsten crucibles at T 2300 °C. Our experiments at 15000-20000 atm, 900-1200 °C indicates that fine powdered GaN were recrystallized to be 10-15 micron polycrystalline platelet. We have tested different solvent, such as H<sub>2</sub>O, ammonia NH<sub>3</sub>, H<sub>2</sub>O, hydrazine NH<sub>2</sub>NH<sub>2</sub>, and N<sub>2</sub> and found that hydrazine enhances reaction rate the most, but not significantly. Benzene, used by Chinese scientist as a solvent, also does not show significant effect. Because GaN grows in a subsolidus (below melting point) region, many nuclei formed will not be eliminated, they will compete for nutrient, and grow to several tens of micron GaN platelet, it is hard to obtain large single crystal GaN. After 15 experiments at the above experimental conditions with different cooling rates, we concluded that this method has a great limit and changed our focus to vapor growth and flux growth.

### (2) vapor growth

Azide, NaN<sub>3</sub>, an explosive and poisonous chemical, is very reactive. Ga metal and azide, with Ga:N molar ratio 1:1, were sealed into the BN-Pt double capsule (Fig.2d), and heated at 800-1000 °C, 15000 atm, with cooling rate 0.0 (at constant temperature) to 3-7 °C/hr. At 800-600 °C, 10000 atm, polycrystalline GaN with grain size of 10-15 micron were synthesized (Fig. 3). Experiment 213 (Table 1) conducted at 10000 atm, 1000-500 °C, with cooling rate 7 °C/hr, however, produced 2 mm diameter, 5 mm length GaN single crystal. X-ray and electron microprobe analysis of the run products confirmed that they are compositional stoichiometric, and the GaN are hexagonal, with  $a = 3.199$ , and  $c = 5.207$ , (Fig. 6) the cell volume of which is a little larger than that grown from Na(OH) flux, the lattice parameter of the latter is  $a = 3.190$ , and  $c = 5.191$ . This method is very promising, and we believe two factors may contribute to the formation of GaN at relatively low temperature: (1) The N-bond of NaN<sub>3</sub> is easy to break, forming dangling bond, which enhances the opportunity for N forming bond with Ga atom. Compared to other N-species, such as NH<sub>3</sub>, NH<sub>2</sub>NH<sub>2</sub>, or N<sub>2</sub>, NaN<sub>3</sub> is much more reactive. (2) Because of small amount of moisture air was inevitably sealed into Pt capsule, Na released from NaN<sub>3</sub> will be oxidized and hydrated as NaOH, and as we found out in flux growth, NaOH is an excellent flux for GaN growth. We are going to continue our investigation and extend our investigation to a new system In-NaN<sub>3</sub>.

### (3) flux growth

Flux growth is a method for crystal growth from molten salt solvent at high temperature and high pressure. The flux increases the solubility of the desired component which congruently dissolves into the flux and lowers the melting point of the solution, thus greatly lowering the N vapor pressure. The key property of the flux is that it produces some association in the melt, such that there are GaN molecules rather than Ga and N atoms. Because of the high-melting point and incongruently melting of GaN, it is essential to find a flux which has a high solubility of GaN without forming a compound, and a low solubility of Pt. Due to the limitation of a theoretical approach to the choice of a flux, the effectiveness of any flux for the growth of GaN must always be tested by experiments, this is especially true for GaN because virtually no references on flux growth of GaN is available. We have chosen a series of fluxes, such as Sn, In, Ga, NaOH, KOH, LiMoO<sub>4</sub>, PbF<sub>2</sub>-PbO-B<sub>2</sub>O<sub>3</sub>, Bi<sub>2</sub>O<sub>3</sub>-PbF<sub>2</sub>, LiCl, KF, some of which have been successfully used in

growing YAG, sapphire and GaAs. Our goal is to find a useful flux for Ga-InN so that this technique can be scaled up for large (10 cm or larger) substrates that can be mass produced by the bulk substrate suppliers of the electronics industry.

In, NaOH, and KOH have been found to be very useful flux for GaN growth. Sub-mm sized crystallites of  $\text{In}_{0.3}\text{Ga}_{0.7}\text{N}$  were grown from GaN powder and In metal, plus hydrazine at 1000 °C, 10000 atm. This is the first discovery of segregate GaN and InGaN phases (Fig. 4 and Fig. 5), and it clearly points towards a different direction for realizing useful bulk growth. By using NaOH as the flux, we have fulfilled a real breakthrough: a large chunk of GaN single crystal (2 mm diameter, 7 mm length) among polycrystalline GaN platelet was grown. After NaOH was washed out by water, clear-cut, white colored GaN shows beautiful hexagonal crystal facets under optical microscopy. The experiment was conducted at 1000 °C, 15000 atm, with cooling rate at 7 °C/hr, and Pt capsule diameter 5 mm, length 12.8 mm). Lattice parameters of the grown GaN are  $a = 3.190$  and  $c = 5.191$  (Fig. 7), which is in excellent agreement with that of the GaN synthesized at 12000-20000 atm, 1200-1600 °C,  $a = 3.189$ ,  $c = 5.186$  by Leszczynski et al. (1993). We are continuing experiments at higher temperature, up to 1400 °C, and slower cooling rate at 3 °C/hr by using NaOH flux. A bismuth may be used to slow down the nucleation rate, so that single crystal, rather than polycrystalline GaN will prevail (Lagan and Thurmond, 1971).

We are going to conduct an extensive materials characterization on the GaN: Microscopy, SEM, TEM of defect structure, optical transmission, photoluminescence and Raman spectrum analysis in the next two months.

#### **Milestones:**

The first year We have focused on three issues:

1. Identification of potential Ga-InN fluxes. We have found several very promising fluxes, In, NaOH, and KOH, which greatly enhances growth rate and crystal quality.
2. Evaluation of vapor growth method, and refined the method by Yamane et al. (1997) by reacting Ga with  $\text{NaN}_3$  at high temperature and high pressure, and produced large GaN crystals.
3. Evaluation of sublimation-condensation method. We concluded that although different hydrous solvent may enhance crystal growth rate, but all solvent tested, including benzene,  $\text{H}_2\text{O}$ , ammonia  $\text{NH}_3\text{H}_2\text{O}$ , hydrazine  $\text{NH}_2\text{NH}_2$ , and  $\text{N}_2$ , did not significantly improve crystal quality. We therefore focus on the previous two methods.

#### **Research plan for 1999:**

We ask continued support from ONR for the second year by accomplishing our goals:

1. Continue our investigation of flux growth technique to identify the more promising and focus research on a single approach to achieve cm sized single crystal. Large diameter Pt capsules, although costly, will be used on promising flux growth experiments. In order to grow large single crystal instead of polycrystalline material, great effort will be put in testing the effect of chemicals such as Bi,  $\text{CaCl}_2$  of reducing the nucleation rate.
2. Continue our research of vapor growth and extend our investigation to In-GaN system. InN has a much lower melting point, therefore we may get even better results than we did in GaN system.

3. Characterize the optoelectronic and material properties of the nitride products by using SEM, TEM on defect structure, optical transmission, photoluminescence and Raman spectrum analysis.

Unipress, the high pressure research center in Polish Academy of Science, is still leading in the field of GaN single crystal growth by growing 6-7 mm sized crystals. Their method of crystal growth, however, has great limitation and is hard to apply to economic mass production in industry. Flux growth, as demonstrated in our first year investigation, can grow crystal at relatively low temperature, and can produce high quality nitride crystals. It is very necessary to explore and find out the most promising flux and refine our crystal growth technology in 1999. In addition to the continuing support from US Geological Survey Dr. Bohlen's lab and Department of Geological and Environmental Science for equipment and Electrical Engineering Department for analytical equipment, we have cooperated with Ken Preston of PDR, Inc., who provided GaN high quality condensed GaN target as the starting material for our crystal growth. We are expecting a very fruitful year in 1999.

**Figure Legend:**

Fig. 1 Schematic illustration of high pressure piston-cylinder facility

Fig. 2 Furnace assembly and double-capsule technique

Fig. 3 Scanning Electron Microscopy image of GaN formed from Ga reacting with  $\text{NaN}_3$  at  $800^\circ\text{C}$ , 10000 atm.

Fig. 4 Backscattering electron image of run product of In-GaN-hydrazine system at  $1000^\circ\text{C}$ , 10000 atm. The bright phase is  $\text{In}_{0.3}\text{Ga}_{0.7}\text{N}$ , and the gray phase is GaN.

Fig. 5 EDS spectrum of GaN phase.

Fig. 6 X-ray diffraction pattern of GaN formed in experiment 218 by vapor growth.

Fig. 7 X-ray diffraction pattern of GaN formed in experiment 225 by NaOH flux growth.

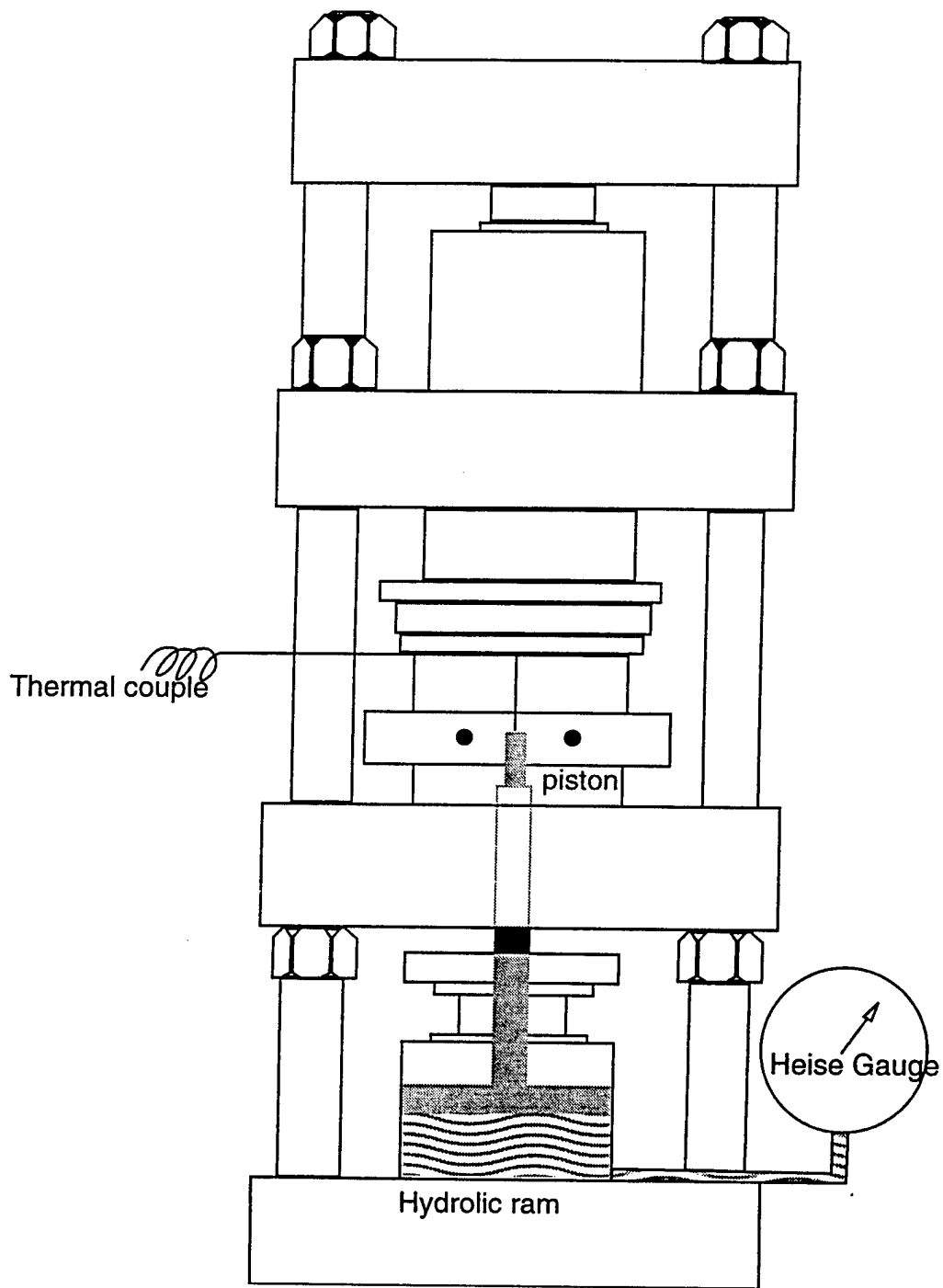
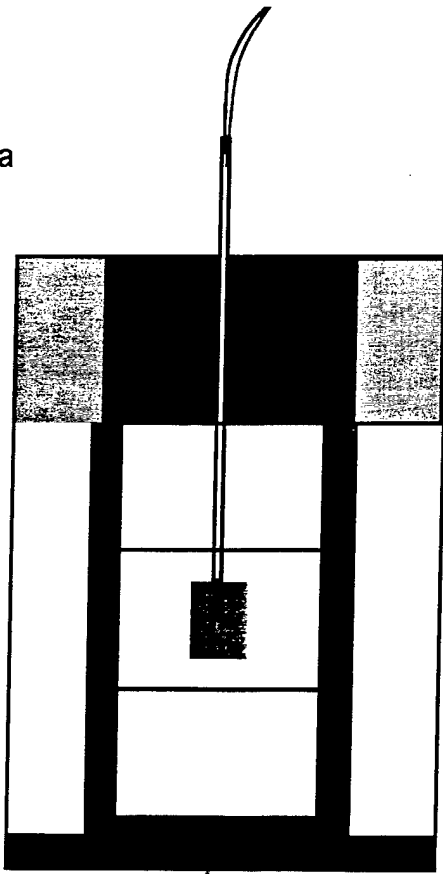
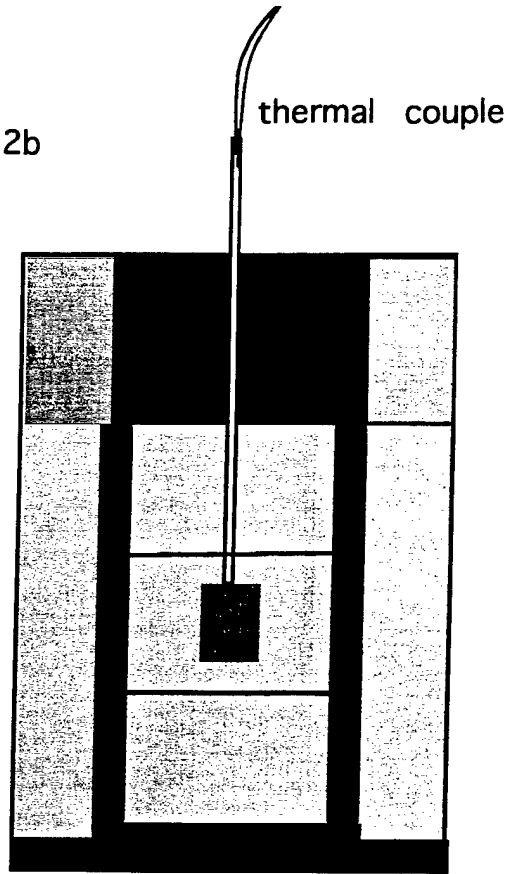

Fig. 1 piston-cylinder press

2a



2b



2c

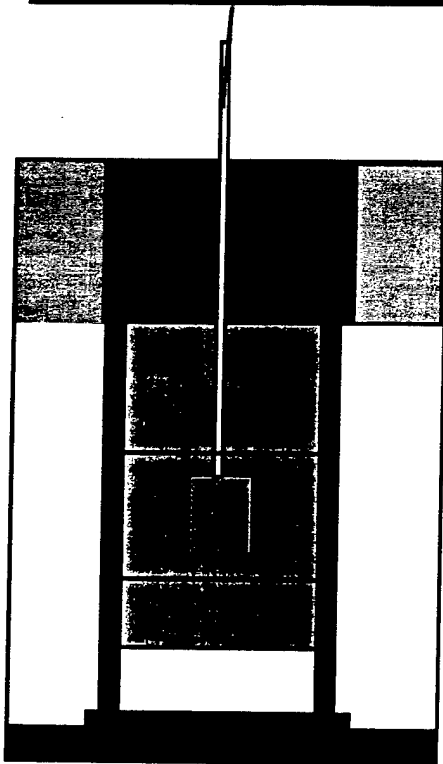

2d

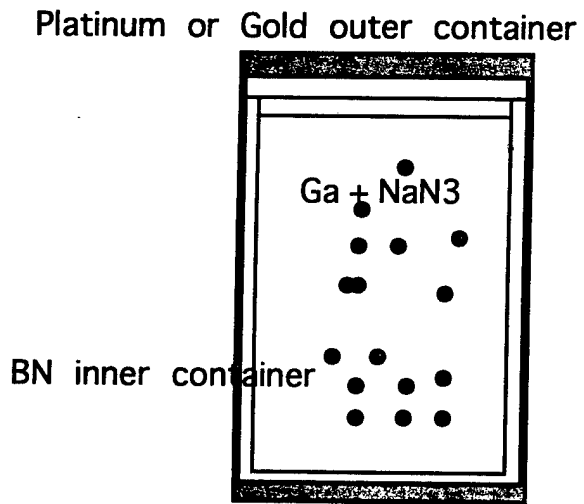

Legend:



NaCl



Graphite



Stainless



steel Pyrophyllite



Al2O3



BaCO3



Container



Pyrex glass



Fused Si glass

1000  
1000  
1000  
1000



Fig. 3



FJ 4

200°C/10

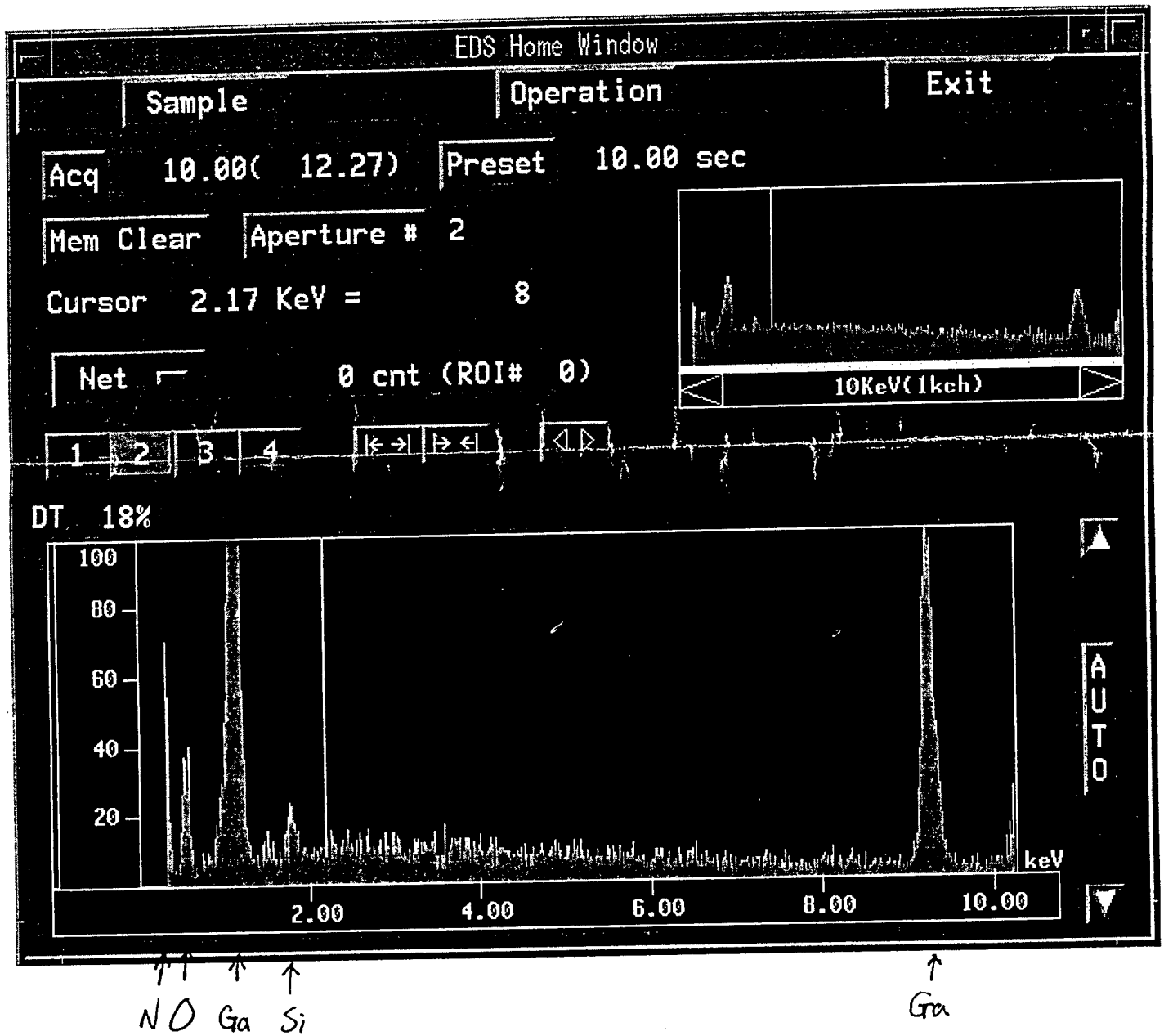

Fig 5 Electron Microprobe analysis of GaN phase

Z03339.RAW

GAN EXPT 218, NAN3 + GA, JUN LIU

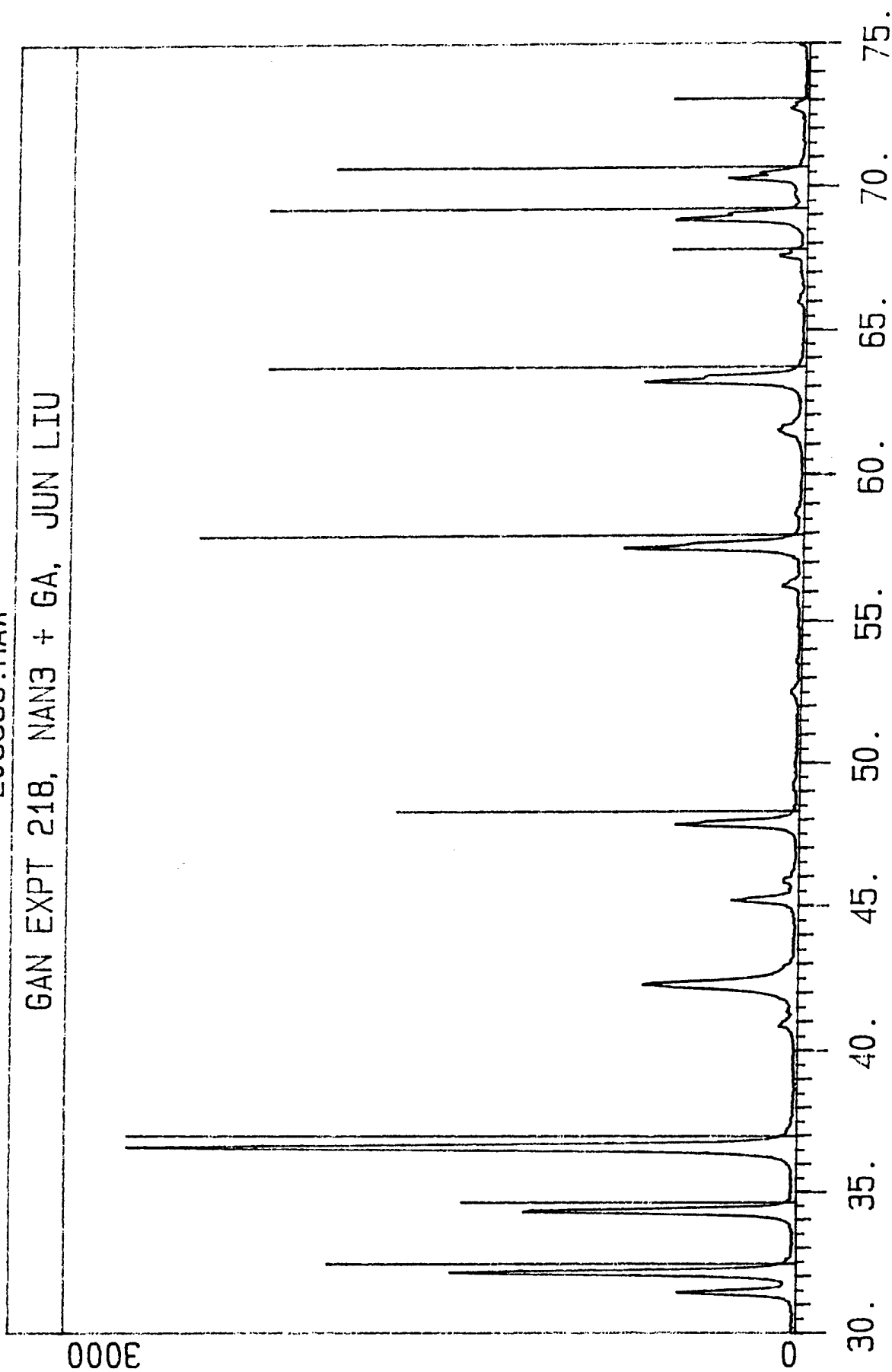
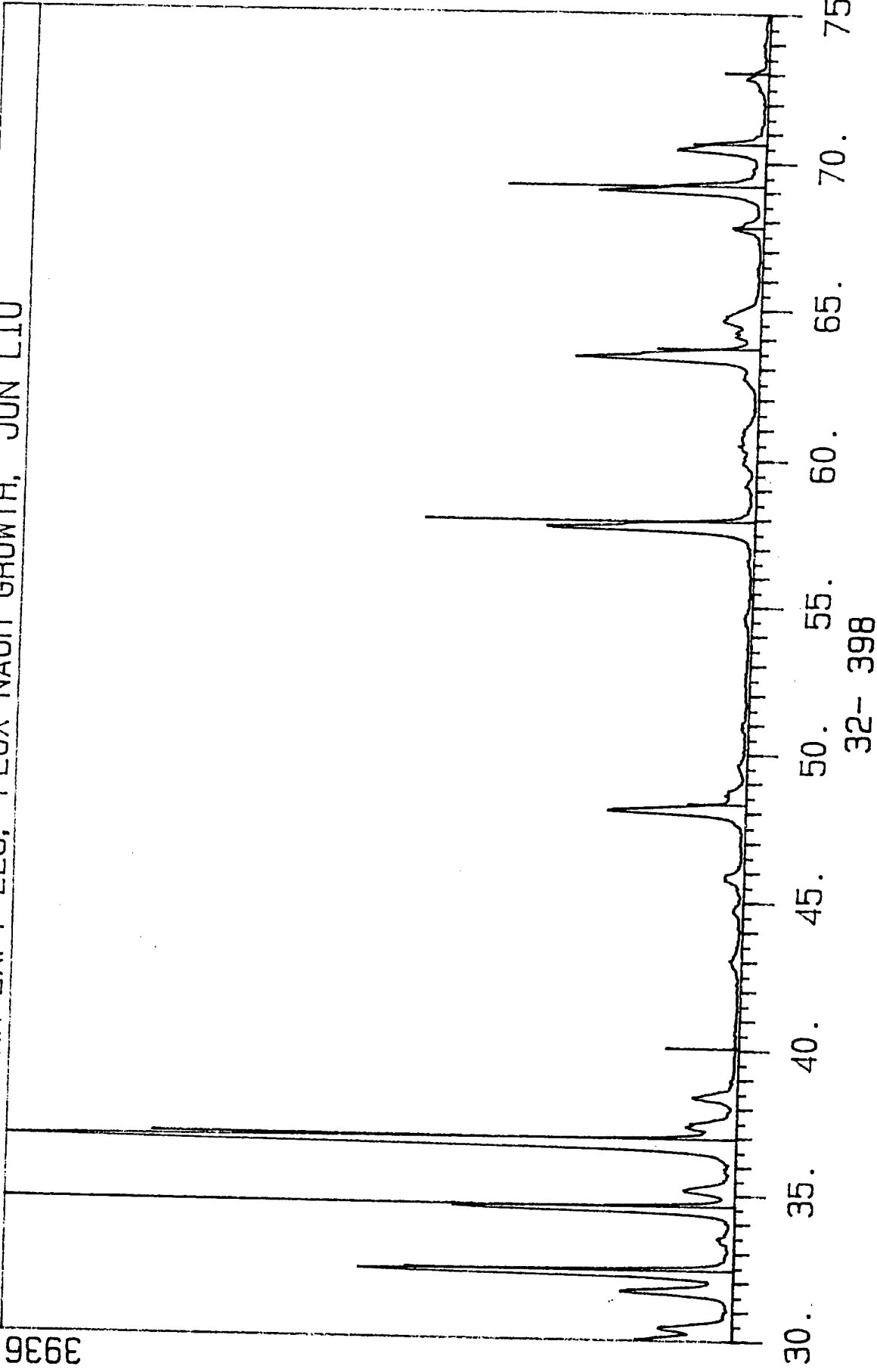

Fig. 6

Z03338.RAW

GAN EXPT 225, FLUX NAOH GROWTH, JUN LIU

3936



32- 398

F<sub>3</sub> 7

REPORT DOCUMENTATION PAGE			Form Approved OMB NO. 0704-0188	
Public reporting burden for this collection of information is estimated to average 1 hour per response, including the time for reviewing instructions, searching existing data sources, gathering and maintaining the data needed, and completing and reviewing the collection of information. Send comment regarding this burden estimate or any other aspect of this collection of information, including suggestions for reducing this burden, to Washington Headquarters Services, Directorate for Information Operations and Reports, 1215 Jefferson Davis Highway, Suite 1204, Arlington, VA 22202-4302, and to the Office of Management and Budget, Paperwork Reduction Project (0704-0188), Washington, DC 20503.				
1. AGENCY USE ONLY (Leave blank)	2. REPORT DATE 9/15/98	3. REPORT TYPE AND DATES COVERED Final 05/30/97 - 05/30/98		
4. TITLE AND SUBTITLE Bulk Growth of GaN		5. FUNDING NUMBERS N00014-97-1-0863		
6. AUTHOR(S) J. S. Harris				
7. PERFORMING ORGANIZATION NAMES(S) AND ADDRESS(ES) Solid State Photonics Lab 328 CISX 4075 Stanford, CA 94305		8. PERFORMING ORGANIZATION REPORT NUMBER		
9. SPONSORING / MONITORING AGENCY NAME(S) AND ADDRESS(ES) Office of Naval Research Ballston Centre Tower One 800 North Quincy Street Arlington, VA 22217-5660		10. SPONSORING / MONITORING AGENCY REPORT NUMBER		
11. SUPPLEMENTARY NOTES The views, opinions and/or findings contained in this report are those of the author(s) and should not be construed as an official Department of the Navy position, policy or decision, unless so designated by other documentation.				
12a. DISTRIBUTION / AVAILABILITY STATEMENT  Approved for public release; distribution unlimited.		12 b. DISTRIBUTION CODE		
13. ABSTRACT (Maximum 200 words)  See attached				
14. SUBJECT TERMS			15. NUMBER OF PAGES 14	
			16. PRICE CODE	
17. SECURITY CLASSIFICATION OR REPORT UNCLASSIFIED	18. SECURITY CLASSIFICATION OF THIS PAGE UNCLASSIFIED	19. SECURITY CLASSIFICATION OF ABSTRACT UNCLASSIFIED	20. LIMITATION OF ABSTRACT  UL	