

320060

JPRS 81878

29 September 1982

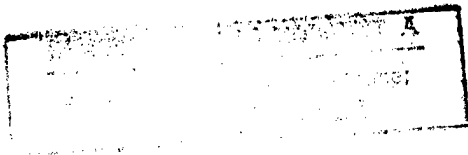

19980917 115

China Report

ECONOMIC AFFAIRS

No. 268

ENERGY: STATUS AND DEVELOPMENT -- IX
AUTOMATION OF ELECTRIC POWER SYSTEMS

FBIS

FOREIGN BROADCAST INFORMATION SERVICE

15
61
A-2

CHINA REPORT
ECONOMIC AFFAIRS

No. 268

ENERGY: STATUS AND DEVELOPMENT -- IX
AUTOMATION OF ELECTRIC POWER SYSTEMS

CONTENTS

Experimental Facility Simulates Control Room of Large Automated Thermal Power Station (DIANSHIJIE, Apr 82).....	1
Computer Supervisory System for Zhengzhou Network (DIANLI JISHU, 5 Jun 82).....	2
Some Problems in the Analog-Digital Integrated Telecontrol Monitoring and Automatic Generation Control System (Jin Zhendong; DIANLI XITONG, Jan 82).....	4
Some Problems of Computer Control Systems for Power Grids (Liu Jue; DIANLI XITONG ZIDONGHUA, Mar 82).....	22
Dispatching Automation for East China Grid (Xu Desen; DIANLI XITONG ZIDONGHUA, Mar 82).....	32
Experience With On-Line Operation of a Power Network Computer Reviewed (Chai Yuhe; DIANLI XITONG ZIDONGHUA, Mar 82).....	36
DJS-6 Minicomputer Used in On-Line Operation (Yue Zizhong; DIANLI XITONG ZIDONGHUA, Mar 82).....	43

EXPERIMENTAL FACILITY SIMULATES CONTROL ROOM OF LARGE AUTOMATED THERMAL POWER STATION

Shanghai DIANSHIJI [ELECTRICAL WORLD] in Chinese No 4, Apr 82, inside front cover

[Text] The Acheng Relay Plant in Heilongjiang has built China's first large capacity thermal power comprehensive automated simulation facility which has recently gone into operation. This laboratory was constructed to simulate the performance of a large-scale thermal power plant and can also test and verify as well as inspect automated power station facilities and thermal generating equipment under simulated operating conditions. It will provide a great boost to the development of China's generating equipment manufacturing industry.



Mathematical simulation section of the facility.

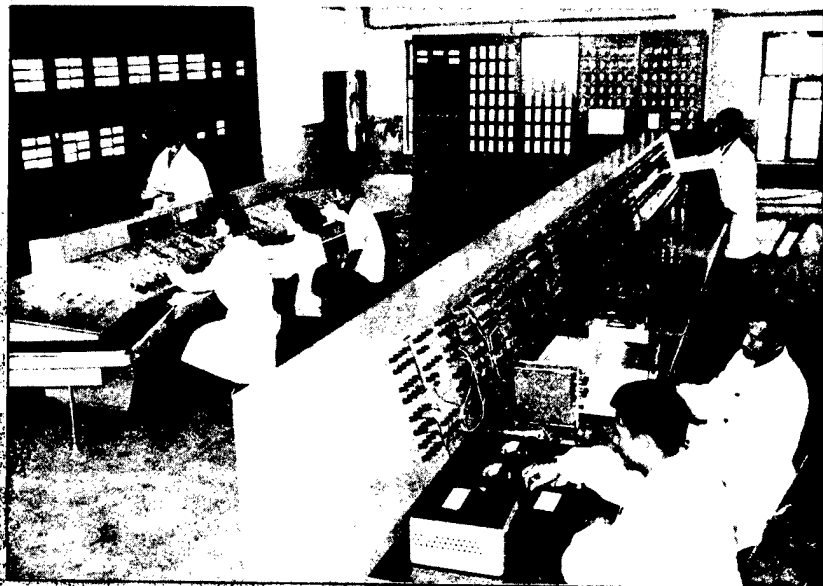

Physical simulation section of the facility

COMPUTER SUPERVISORY SYSTEM FOR ZHENGZHOU NETWORK

Beijing DIANLI JISHU [ELECTRIC POWER] in Chinese, No 6, 5 Jun 82 p 78

[Article: "Computer Monitoring and Control System for Dispatching for the Zhengzhou Power Supply Network"]

[Text] The Zhengzhou Power Supply Bureau has implemented computer on-line monitoring and control of four 35-kilovolt substations, three 110-kilovolt substations, one 220-kilovolt substation and some of the equipment of one power plant within the prefecture. The system uses the domestically produced DJS-131 model single computer system with a total of 22 functions, including 45 frames of color displays. They include:

I. Normal Display

1. The main connecting lines of each substation. 2. The loads of each plant and each substation. 3. The tidal current of the main power network. 4. Total addition of power in the Zhengzhou Prefecture.

II. Warning and display for accidents and abnormal situations

5. Overload warning. 6. Forecast signals and warning. 7. Accident warning and recording. 8. Display of the main line for final operating method after an important power line has jumped the switch.

III. Control

9. Three cut-off devices of open loop control. 10. Initiation and cut-off of the capacitors of two substations by closed loop control.

IV. File management

11. Plans for relay protection at each substation. 12. Sampling schedule for the main transformers.

V. Tabulation and printing

13. Two tabulating devices can print 176 quantities for producing tables and for accident records.

VI. Other functions

14. Printout of the displays on screen. 15. Revising non-dynamic quantities in the picture on screen. 16. Sustaining 15-second displays of dynamic parameters or displaying fixed dynamic states. 17. Standard time display. 18. Adjusting for standard time. 19. Remote measured data processing. 20. Automatically starting the preparatory tabulating device. 21. Automatically starting the internal programs. 22. Dynamic inspection of the telekinetic interface.

The entire system began operation at the end of last year (remote measurements, remote communications of quantities of data all began operation last August). Up to the end of February of this year, the system's rate of utilization was 98.3 percent. The average down time was 373 hours.

The system performed the 22 functions described above (including the display of 45 frames). They have served a definite function to improve the level of management of the high voltage power network and to improve the conditions for safe operation of the power network and the quality of electricity. They have also accumulated experience for further realizing automatic control in the future. At present, the reliability of the system must be further improved on the present foundation and practical economic results must be further achieved by continuing to expand the function of the monitoring and control system including economical dispatching and operation.

9296

CSO: 4013/97

SOME PROBLEMS IN THE ANALOG-DIGITAL INTEGRATED TELECONTROL MONITORING AND AUTOMATIC GENERATION CONTROL SYSTEM

Nanjing DIANLI XITONG ZIDONGHUA [AUTOMATION OF ELECTRIC POWER SYSTEMS] in Chinese, No 1, Jan 82, pp 37-47

[Article by Jin Zhendong [6855 2182 2639] of the Nanjing Automation Research Institute: "Some Problems in Combined Digital-Analog Remote Monitoring and Control and Automatic Generation Control System (CAS)"]

[Abstract] This article discusses the two main systems in the automation of power network dispatching, i.e., the feasibility of integrating the safety monitoring and control system and the system for controlled automatic generation and analyzes the conditions and ways to realize integration. It also gives a brief introduction to the integrated digital-analog controlled automatic generation system and safety monitoring and control system (CAS) developed for the Beijing-Tianjin-Tangshan Power Network.

The definitions of abbreviations frequently used in this article are:

SCADA monitoring, control and data gathering, or remote monitoring and control

AGC Automatic generation control

EDC Economical dispatching control

LFC Load frequency control

[Text] I. General Description

Safety monitoring and control and controlled automatic generation of electricity in the power system, including automatic frequency modulation and economical operation of the power network, are the two main tasks in the automation of power network dispatching. The research subjects of these two tasks are

*This article was received in June 1981

different. The first involves research in data gathering, data transmission, data processing, output and display for power networks, with special emphasis on the study of gathering data on operating conditions during accidents. Such efforts enable the power system to operate safely. The latter studies load disturbance during normal operation of the power network, controlling the generated output of electricity according to the principles of automatic regulation and the standards for economical operation so that the generated output of electricity of the power network follows changes in the actual loads, so that the frequency of the power network and the clock error will be within a specified range and so that the operating cost of the power network can be kept low. This effort enables the power network to operate economically.

Because the research subjects are different, therefore these two tasks have traditionally been two separate categories. As a result, two completely unrelated systems of equipment to realize these two tasks have emerged. The first is called the safety monitoring and control system for a power network (Before the mid-1960s, it mainly involved telemechanics). The latter is called frequency modulation devices or frequency modulation systems for a power network. Because these two tasks are both heavy, therefore each has a very huge system.

Before the mid-1960s, every nation emphasized the study of automatic generation control for power networks in studying the automation of power network dispatching, and a lot of work was done. A relatively complete theory was formed and many types of devices and systems for automatic generation control were built. In 1965, after the major power failure of the northeast power network in the United States occurred, each country shifted attention from studying automation of power network dispatching to safety monitoring and control of power networks. How to utilize digital computers and telemechanic technology to realize safety monitoring and control of power networks became the key research subjects. Therefore, safety monitoring and control systems, including telemechanic systems developed rapidly. But the equipment of these two types of systems duplicated each other, the channels were crowded, and many conflicts were formed. People thus asked whether these two systems of traditionally different categories could be combined.

As technology developed, people renewed their study of these two tasks and they discovered that on the basis of new technology, it was possible to combine these two tasks that seemingly were completely different. Therefore, the United States began exploring this question after 1965 and developed new automated dispatching systems, such as the direct digital-analog dispatching system, the direct digital monitoring and control system, and the combined remote monitoring and control and automatic generation control system (II). Whether these two systems of different categories can be combined and how can they be combined are questions that are discussed in this article.

II. The Question Regarding the Method of Establishing an Automatic Generation Control System for Power Networks

Automatic generation control for a power network (AGC) used to be called automatic frequency modulation and economical operation. It can be realized by

two systems, i.e., the so-called scattered type and centralized type. Each has its own advantages and shortcomings. The one that has the possibility to combine with the SCADA system is the latter. Because of the need to analyze the problem, here we will give a brief retrospect of the scattered AGC system.

The main characteristic of the scattered automatic generation control system is the emphasis on reflecting the frequency deviation value Δf (basis for frequency regulation) of the power network required by the load of the power network and the incremental rate $\int \Delta f dt$ of the power network (basis for the economical distribution of active power), both automatically measured by AGC equipment in the power plants of the network. The output of each of the generators of a plant is regulated accordingly. Because the incremental rate (coal consumption, water consumption) of the generators is known, therefore, as long as the Δf and $\int \Delta f dt$ measured by each plant are consistent, this AGC system can control the operation of every generator in the power network when the incremental rates are equal, and the quality of the frequency of the power network can be guaranteed. The main starting point proposed by this system is that it does not utilize channels for information transmission. All automatic regulators on the generators can operate according to established patterns and they are mutually unrelated to avoid affecting the operational reliability of the equipment due to malfunctions in the information channels. This AGC system was once widely utilized in the Soviet Union [2]. Our nation also did a lot of work in this regard. The simple block diagram of this system is shown in Figure 1.

When using a scattered AGC system, the problem of combining the SCADA system and the AGC system does not exist because the two are unrelated.

Yet, the AGC system has some problems in principle and in practice that are difficult to solve. One is the problem of errors in the measurement of Δf and $\int \Delta f dt$. Because consistency in the measurement of the frequency difference Δf at each power plant is impossible, the values of $\int \Delta f dt$ are different, and they affect the economical distribution among the power plants. The second problem is that correction of line loss of the power network cannot be considered because calculations of line corrections are a system-wide problem and they cannot be done locally at one power plant. The third is that power exchange on communications lines cannot be controlled, thus the power between the systems of the joint system cannot be regulated according to the frequency difference in the power network and according to the telecommunications bias code (TBC). These are the main shortcomings of this AGC system.

Power network frequency

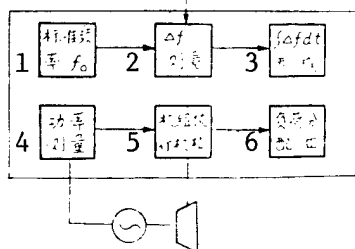
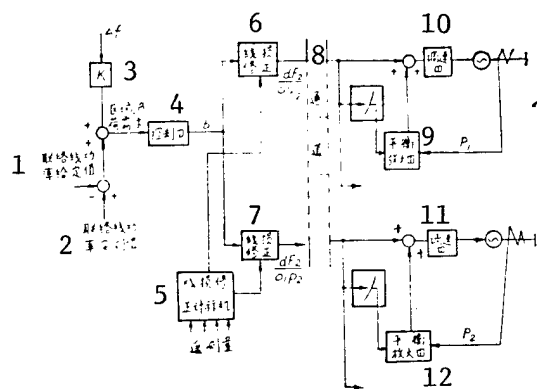

Figure 1. Scattered AGC system

1. Standard frequency
2. Δf measurement
3. $\int \Delta f dt$ formation
4. Power measurement
5. Execution mechanism of a generator
6. Load distributor

Opposite the scattered AGC system is the centralized AGC system. The main principle of this system is that the frequency difference of the power network and the incremental rate are both measured and produced by the dispatching center. The load requirement signals of the power network are sent via special channels to the electricity generation controller at each power plant. The power plant then carries out instantaneous adjustment and economical distribution among the generators according to this signal to guarantee constancy of the frequency of the power network and an equal incremental rate among the generators.

Because the centralized AGC system sends out a uniform control signal from the dispatching center, therefore the problem of the precision of measuring Δf and $\int \Delta f dt$ encountered in the scattered AGC system does not exist. It can utilize the data measured by telemechanic devices to compute the incremental rates and line corrections for each power plant on a computer or special computational devices. The regulatory code TBC is more easily realized in the centralized AGC system. Because it does not have the inherent shortcomings of the scattered AGC system, therefore many nations have utilized this method and have developed corresponding devices. Its typical structure is shown in the Figure [3].



1. Given value of power of the communications line
2. Actually measured value of power of the communications line
3. Load requirements in zone A
4. Controller
5. Line loss correction computer
Remotely measured quantity
6. Line loss correction
7. Line loss correction
8. Channel
9. Balance amplifier
10. Governor
11. Governor
12. Balance amplifier

Figure 2. Centralized AGC System

China's northeast power network also studied an AGC system similar to this type of structure.

Compared to the scattered AGC system, this centralized AGC system requires special channels for the transmission of commands. When the channels are crowded, there are many practical problems that are difficult to solve. In addition, because we want to avoid mistaken adjustment when the channel is interrupted, the transmitted signal is the deviation signal (Δf , Δp) needed by the power network. The integrated signal serving as the incremental rate still needs to be formed at the power plant. Therefore, the equipment at each of the power plants must carry out integration at the same speed. This requires

precise adjustment. The starting positions of the integrators are not fixed and the problem of adjusting the starting point similar to that in the scattered AGC system exists. These two aspects are both sources of errors.

III. The Trend in Combining the SCADA System and the AGC System

The function of the SCADA system that is similar to the function of the AGC system is remote adjustment, mainly giving manual commands.

Since the 1970s, commands sent out for remote adjustment by the SCADA system have all been transmitted in codes. It is a time sharing principle. Therefore, regardless of whether it is cyclic data transmission or polling, the codes cannot transmit continuous quantities ($\int(k\Delta f + \Delta p)dt$) of load requirements needed in the centralized AGC system described above. And because of this, past SCADA systems and AGC systems were separated and even today, they are still separated in many nations.

As computer technology and telemechanic technology develop, we find that these two different systems can be combined in many aspects. For example, the real time data needed by the computer used for economical dispatching and by the computer for safety monitoring and control are the same. As long as the speed and the storage capacity of the computers are sufficient, it is possible to combine the two. Also, for example, the output circuits of remote adjustment of the SCADA system and the output circuits of the AGC system all control the same object (the power regulator of the generator). Because of this, since the 1970s, some papers published in the United States have proposed the idea of combining the SCADA and the AGC systems, and a lot of work has been done. The typical structure is shown in Figure 3.

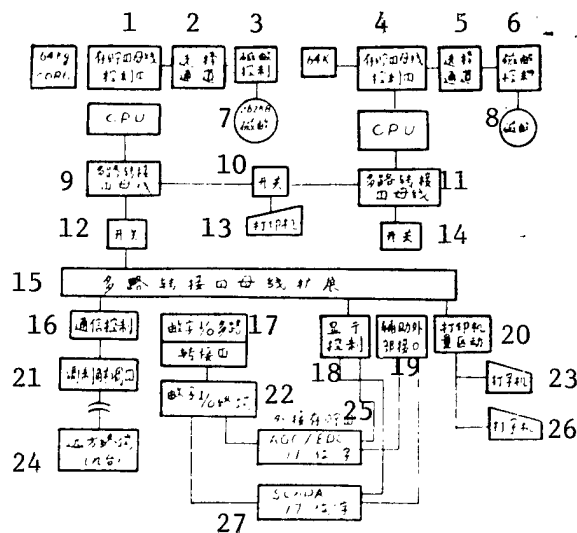

Figure 3. Combined SCADA/AGC

[Key to Fig. 3 on following page]

[Key to Fig. 3]

- | | |
|-----------------------------------|--|
| 1. Controller of the memory bus | 15. Bus expansion of the multiplex connector |
| 2. Channel selection | 16. Communications control |
| 3. Magnetic drum control | 17. Drum word I/O multiplex connector |
| 4. Controller of the memory bus | 18. Display control |
| 5. Channel selection | 19. Auxiliary peripheral interface |
| 6. Magnetic drum control | 20. Printer drive |
| 7. Magnetic drum | 21. Modulator-demodulator |
| 8. Magnetic drum | 22. Drum word I/O terminal |
| 9. Bus of the multiplex connector | 23. Printer |
| 10. Switch | 24. Remote terminal (n units) |
| 11. Bus of multiplex connector | 25. External memory |
| 12. Switch | 26. Printer |
| 13. Printer | 27. "17"bit/word |
| 14. Switch | |

IV. The Way To Solve the Problem of Combining the SCADA Remote Adjustment Channel and the AGC Adjustment Channel

It can be seen from the above analysis that the main problem in combining the SCADA system and the AGC system is the compatibility of down line transmission of information. The main conflict is the method of information transmission in the AGC system. If we insist on using the load requirement signal of the power network region in the transmission system of the AGC system, then because this is a continuous signal, the two will not be compatible. Therefore, we must change the load requirement signal that is continuously transmitted to an adjusted value signal transmitted on a time-shared basis (the total power of the power plant or the value of the incremental rate of the power network) in codes like the remote adjustment commands for local storage. The load distribution among the generators within the power plant can be realized by the P-P curve converted from the incremental rate curve or by the incremental rate curve. As long as this is done, the SCADA and the AGC channels can be compatible. In other words, to combine the two, the AGC system cannot use the traditional method of adjustment by the error signals or the incremental signals.

The economical superiority of integrating the SCADA system and the AGC system is obvious. This integration can combine the computers of the SCADA system and the computers of the AGC system at the dispatching center. It can abolish a large number of special channels, reduce the number of interfaces between computers and telemechanic devices. It can simplify the systems for receiving instructions to adjust the generators at the power plants and at the power stations. Also, the reliability of transmitting regulatory signals is improved. Because the fixed value commands for remote adjustment transmitted by the SCADA system use carefully designed anti-jamming codes, its transmission reliability is much higher than continuous commands transmitted in the past.

Compared to the transmission of continuous commands, time shared transmission of adjusted values also has its shortcomings. The quality of adjustment is slightly poorer than the former. The reason is obvious. The former is a

closed loop system of continuous responses while the latter is a closed loop system of time share responses. Because of time sharing, there is a time delay from the beginning of disturbance in the system to the sending of fixed value commands when compared to the continuous transmission of regional load requirements. This is equivalent to adding a nonlinear time delay in the closed loop regulatory system causing the quality of adjustment to drop. To guarantee better quality of adjustment, the cycle of issuing commands in the comprehensive CAS system should be limited. This involves corresponding regulations concerning the requirements of the speed of issuing commands for remote adjustment.

V. A Concrete Method To Realize the CAS System

In summary, it is possible to combine the SCADA system and the AGC system if the method of issuing adjustment commands in the AGC system uses the adjusted values of the generated output of electricity of the station whose power is being drawn or time shared transmission of the adjusted values of the incremental rate. We began in 1979 to develop a CAS system for the Beijing-Tianjin-Tangshan power network. But when constructing the system, the following problems need to be considered and determined.

(1) The method to realize economical distribution and output among the generators. The distribution of output among the generators within the power plant originally could be based on the adjusted values transmitted to the power plant by the dispatching center and received by the special load distributor. For example, when the dispatching station sends a command for the total generated output of electricity for the whole plant, we can set the so-called p-p function generator. If it sends incremental rate values, then we can set the so-called b-p function generator and obtain the numerical values of economical output of each generator at the time from the output of the curve generator and then transmit them to the corresponding p execution devices.

The use of p-p or b-p function generators at the locality is necessary for the power plants that have main steam pipes. This is because there are more combinations of generators and boilers and it is not easy for the dispatching station to grasp them at any moment, therefore they can only be adjusted locally.

But, the function generator is still very cumbersome. The main pipes are present only in power plants with medium and small generators. This is because in the large power networks, medium and small generators do not modulate the frequency anymore. Therefore, the objects of control in the AGC system of the large power networks in foreign nations are mainly the generators of large hydroelectric power stations and new types of large thermal power stations. Among these types of controlled objects, the generators can be directly controlled. The generators of over 100 MW of our nation's newly built large thermal power plants are all generator-boiler units. The dispatching center directly controls the generators and sends out the adjusted output values for the single generator. This eliminates the function generators and simplifies the equipment at the station under control. Based on this consideration, we discussed with concerned units and decided to let the central dispatching station of the Beijing-Tianjin-Tangshan Power Network directly issue commands

to control 19 large generators when we developed the CAS system for the Beijing-Tianjin-Tangshan Power Network. The benefit of doing so is that it simplifies the AGC equipment of the power plant and fully develops the function of the computer of the CAS system at the dispatching center. The shortcoming is that the time for this time-shared system to complete one cycle is longer than the time for completing one cycle in controlling only the power plants, and this may affect the quality of adjustment.

(2) The method of constructing the circuit

The principle of designing the circuits in developing the CAS system is whether to use the digital computer to perform all AGC tasks (including EDC and LFC) or to use the digital-analog method to share the AGC tasks.

In view of the load characteristics of the power system, the load can be divided into three types: One is the high frequency component that has a high frequency but a small amplitude. The second is the pulsed load with a frequency of from 10 seconds to 2 to 3 minutes. The third is the continually varying load, as shown in Figure 4 [Note].

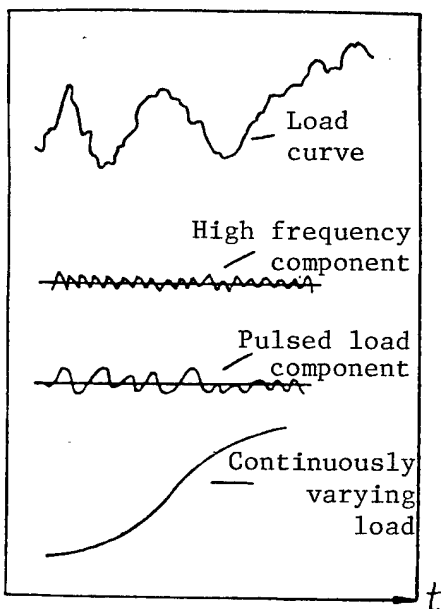

Figure 4. Analysis of the load of a power system

Note: This figure was taken from "Automation of Power Systems", compiled by Zhejiang University, 1978 edition.

The task of the AGC system is aimed at adjusting the second and third types of loads. The commands for the load of the third type should be issued after the computer has calculated its economical operation. Here, we will mainly discuss which method to use in adjusting the second type of load. One method is to let the computer perform the entire task like the MEPPCC of the United States. It uses two small computers. One is responsible for calculating economical operation and the other is responsible for sending the computed results to the various power plants under its control. But the task of the

computer is heavy because to solve the load fluctuations with a cycle of 10 seconds, the cycle for issuing AGC commands must be smaller than 10 seconds. For example, in issuing commands to 19 generators of the Beijing-Tianjin-Tangshan Power Network, one cycle takes about 5.7 seconds and commands are issued continuously. In each interval of 5.7 seconds, the next load distribution must be calculated again, and every 300 milliseconds, the cycle must be interrupted once to send the command to the telemechanic devices. Because the computer is not dedicated to a specific function, it must also perform safety monitoring and controlling tasks. Therefore, in an automated dispatching system that does not have two on-line computers in operation, it is reasonable to use analog computational devices to regulate load changes (LFC) that fluctuate every 10 seconds to 2 to 3 minutes. This means using the digital computer to perform the tasks of calculating the economical distribution once every few minutes and to send its adjusted value (EDC) while using the analog computing device to send proportional adjustment signals and incremental rate signals once every few seconds to realize LFC regulation. The quality of regulation of the digital-analog CAS system arranged this way will be better than that of the pure digital CAS system.

(3) Configuration of the Signals for Proportional Adjustment

To reduce the amplitude of frequency fluctuation of the power network and hasten the speed of adjustment, the combined CAS system provides signals for proportional adjustment, i.e., $k\Delta f + \Delta p$. The problem that needs to be studied is the relationship between this signal and the proportional signals in the power regulator of the generator, i.e., the locally measured Δf .

As analyzed in section two, locally formed Δf causes an inconsistency due to the precision of measuring Δf . This creates a problem of so-called competing for loads among the generators. Also, this proportional signal does not include the exchange power of the communications lines. Therefore we cannot differentiate between the load disturbance of this system and the external system. Therefore, using locally formed Δf signals as regulatory signals when Δf is very small is not suitable. Using proportional signals ($k\Delta f + \Delta p$) produced centrally at the dispatching center avoids the above shortcoming. But when using the locally measured Δf signal as the proportional signal input to the power regulator, the speed of regulation can be faster because it is a signal that continuously reflects the change in Δf . Therefore, the proportional signals of the dispatching center and those locally formed should be rationally coordinated. When Δf is smaller, the local Δf signal should not function (i.e., designing a dead zone) and only the ($k\Delta f + \Delta p$) signal sent by the dispatching center can function. When Δf is larger, the function of both signals can be added. The result of such an arrangement guarantees the precision of Δf and prevents the competition for the load among the generators and it can also hasten the speed of adjustment. The frequency modulation plan for the Beijing-Tianjin-Tangshan Power Network stipulates that the locally measured Δf has a dead zone of $\pm 0.05\text{HZ}$.

VI. The Design Principles of the Analog Computational Device in the Combined CAS System

The main task of the analog computational device is to track the variable pulsed loads of the power network and perform LFC regulation.

According to domestic operating experience and foreign documents [4], the main tasks of AGC are as follows:

1. To maintain the frequency f of the power network at a constant value, (In our nation, it is set at $|\Delta f| \leq \pm 0.2 \text{HZ}$);
2. To maintain the exchange power p of the communications line at the planned and stipulated value;
3. To distribute the power among the generators of each subregion of the power network according to the principles of economy.

In the CAS system consisting entirely of digital computers, these three requirements are included in the output commands issued for the single generator by the system. When using an analog device to perform the LFC function, this device mainly solves the first two tasks, but in the course of adjustment, the principle of economically distributing the load must also be manifested. When performing LFC adjustments, the combined CAS system functions according to the regulatory criteria

$$\Delta P_s + (k\Delta f + \Delta p) + s \int_0^t (k\Delta f + \Delta p) dt = 0$$

where s is the constant for the speed of integration and Δp , is the load deficiency of the system.

To satisfy the above regulatory criteria, and taking into consideration the operating requirements of the power network, the design principles of the analog computational device are:

- (a) to measure $\Delta f = f_0 - f$ with accuracy to $\pm 0.01 \text{HZ}$;
- (b) to measure $\Delta p = \pm (p \text{ given } -p_1 \text{ } -p_2)$;
 p_1, p_2 are the power of two monitored communications lines respectively.
- (c) to calculate $k\Delta f + \Delta p$;
 k is the frequency-power conversion coefficient
- (d) to calculate $s \int_0^t (k\Delta f + \Delta p) dt$;
 s is the integration time constant
- (e) to calculate the time pulse of the power network and the standard marking difference ΔT ;
- (f) to judge the interval of load disturbance. When a disturbance in the load of the local system occurs, the signs of $k\Delta f$ and Δp must be controlled, otherwise they should be opposite in sign;

- (g) When the load disturbance occurs in the external system, but $|\Delta f| < 0.2 \text{ Hz}$, the Δp component in $(k\Delta f - \Delta p)$ should be controlled and made equal to zero to support the external system.
- (h) When $|\Delta T| \geq 0.4$ second $|\Delta T| \leq -0.4$ second, correct the value of f_0 :
- $\Delta T \geq +0.4$ second, $f_0 = 5002$
 $\Delta T \leq -0.4$ second, $f_0 = 4998$
 $(|\Delta T| < 0.4$ second, $f_0 = 5000)$
to automatically correct the clock error.
- (i) adjust the sign of Δp according to the direction of flow of power on the communications line;
- (h) $k\Delta f + \Delta p$ and $\int (k\Delta f + \Delta p) dt$ are sent to the remote adjustment transmitter via the interface, ΔT is sent to the display.

In the CAS system we developed for the Beijing-Tianjin-Tangshan Power Network, we followed the above principle to design the analog computing device. We need to explain that the analog computing device computes and sends digital quantities (3-digit BCD codes). It is called analog because its control principles are similar to the controlling method of an analog computer.

VII. The Question of Economical Distribution of Power Among Generators of the Combined CAS System

The purpose of issuing commands directly to the generator is to simplify the AGC execution devices at the power plant and to eliminate the function generator so that the AGC devices at the power plant can operate in a fixed state. Yet, the incremental rate curve of the generator must be stored in the memory of the computer of the CAS system at the dispatching station. When using the analog computing device to send unified adjustment signals, how can we solve the problem of economical distribution of power among the generators? To solve this problem, we first study the approximate expression of the incremental rate curve of the generator. Related reference [5] points out, the b-p curve of a generator can be simplified to and approximated by the broken lines of 2 to 3 segments shown in Figure 5. The principle of using approximate broken lines is to make the area under the broken line and the curve equal.

The relationship $p=f(b)$ on the broken line described above can be expressed as

$$p_{i+1} = p_{oi} + a_i (b_{i+1} - b_i)$$

where p_{oi} is a certain starting point on the broken line segment. In the CAS system, this is given by the computer or the dispatcher at a fixed time. a_i is the slope of that broken line, $a_i = \Delta p_i / \Delta b_i$. Therefore, this relationship can be realized by the receiver of AGC commands on the generator. The method to realize this is to control the input resistance of the $\int (k\Delta f + \Delta p) dt$ branch

of the amplifier according to the output voltage (representing the adjusted value of output of a certain generator) of the end level amplifier after D/A conversion, i.e., changing the amplification coefficient to simulate the slope of the broken line of the b-p curve. The circuit diagram is shown in Figure 6.

When the output voltage of the end level amplifier is smaller than the value equivalent to the value of P_{01} , the analog switch connected to R_0 connects. The amplification coefficient of the P_b branch is R_f/R_0 . When it is larger than P_{01} , the analog switch connected to R_1 connects, and the amplification coefficient becomes R_f/R_1 . When it is larger than P_{02} , the analog switch connected to R_2 connects, and the amplification coefficient becomes R_f/R_2 , respectively corresponding to the slopes of the three broken line segments. After using this circuit, we can realize an economical distribution of output among the generators during LFC regulation.

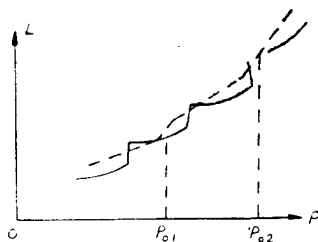

Figure 5. b-p curve of the steam turbine generator

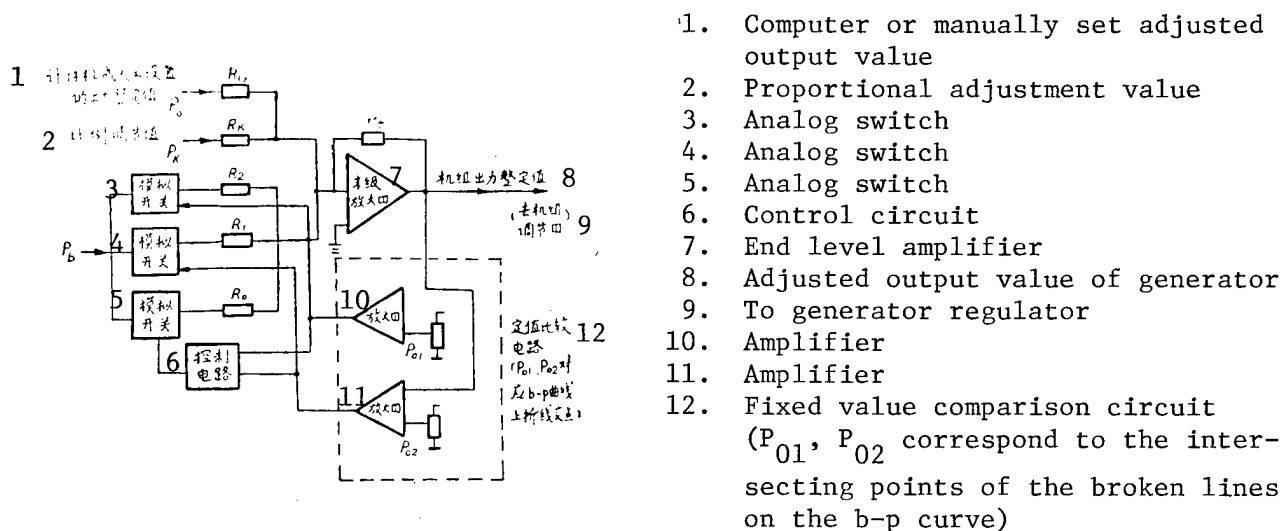

Figure 6. AGC signal receiving circuit

VIII. Brief Description of the Principles of the Circuits of the Combined CAS System

Since 1979, we have developed a digital-analog CAS system for the Central Dispatching Station of the Beijing Administrative Bureau of Electric Power according to the theory described above. It includes a system of two SD-176 computers and an interface with telemechanic devices, an analog computing device, a fixed value setting console, a control modulator-demodulator, and a multiplex switch for connecting with the frequency channels, SZY-301:n type remote adjustment signal transmitter, and terminals to control 19 generators at 7 power plants. The configuration is shown in Figure 7.

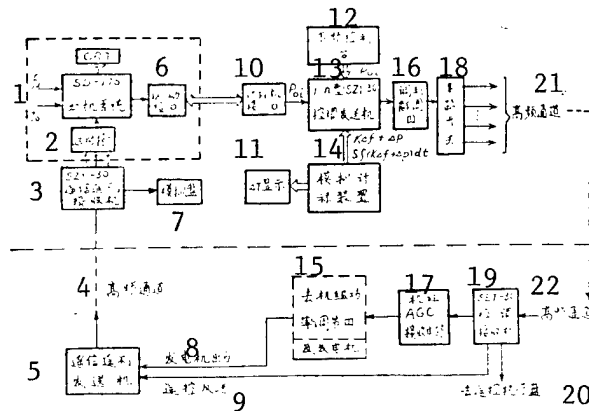

Figure 7. Combined CAS System

- | | |
|---|---|
| 1. Double computer system | 12. Frequency modulation control console |
| 2. Telemechanic interface | 13. 1:n SZY-30 control and adjustment transmitter |
| 3. SZY-30 remote communications and remote testing receiver | 14. Analog computing device |
| 4. High frequency channel | 15. To power regulator of generator |
| 5. Remote communications and remote testing transmitter | 16. Modulator-demodulator |
| 6. Telemechanic interface | 17. AGC receiving circuit of generator |
| 7. Analog panel | 18. Multiplex switch |
| 8. Generator output | 19. SEY-30 control and adjustment receiver |
| 9. Reverse transmission of remote control | 20. To remote control execution panel |
| 10. Computer interface | 21. High frequency channel |
| 11. ΔT display | 22. High frequency channel |

Because this is a huge closed loop system, its main principles are briefly described in the following.

The 1:n type SZY-30 remote control and remote adjustment transmitter is designed to receive remote control and remote adjustment commands of the SD-176 computers, manually set remote control and remote adjustment commands, and the LFC signals of the analog device.

(a) Computer issued AGC commands.

The SZY-30 remote control communications and adjustment transmitter is connected to the SD-176 by 21 information lines. Among them, the computer has 12 address and data lines to telemechanic devices, 2 object command strobe pulse lines, 1 remote control command execution line, and 1 computer breakdown signal line. The telemechanic device has 1 notification line to the computer to notify the completion of transmission of the object command, a notification line to allow execution of remote controlled operation, an overflow signal of the incremental rate integrator of the analog computing device, a notification line to notify format error of the object command issued by the computer, a notification line to notify a breakdown in the remote adjustment transmitter.

The method of issuing commands by the computer is to send the plant number, the generator number (during remote control operations, it is the nature of remote control) to be regulated, and the adjusted value (switch number) via 12 address and data lines in two batches to the remote control and remote adjustment receiver. The first batch includes the plant number and the number of the generator to be regulated remotely, (or the nature of remote control operation). The second batch includes the adjusted value of remote adjustment (or the switch number of be remotely controlled) totalling a 3-digit BCD code. The time for sending the data twice is about 10 μ s. After the plant number has been received, the SZY-30 remote control and remote adjustment transmitter and receiver will control the multiplex switch according to the plant number and connect the output of the modulator-demodulator to the corresponding high frequency channel. After 20 ms, the channel stabilizes and transmission of an adjusted value command to the object begins (or remote control operation commands). When transmission of this command is completed, the computer is notified via the corresponding interrupt request line. The computer then repeats the above procedure and sends out the adjustment command for the next object. When the computer performs only the EDC task, it only sends the output value of economical distribution to all the controlled objects at fixed intervals (for example, once every five minutes). When it also performs the LFC task, it will issue a command every 300 ms to all controlled objects back and forth in a cycle.

(b) Manually issuing AGC commands

This is performed on the remote control and remote adjustment operating console. It includes the plant number for remote control and remote adjustment, characteristics of control and adjustment, the nature of the remote control operation (jump switch controller), the number of the generator to be remotely regulated, and the 3-digit BCD code (remote control switch number or adjusted value for remote adjustment). In remote control operations, execution commands are issued only after double checking (The computer issues a remote control command only after the telemechanic device has checked and sent back the signal. The computer is notified via the execution allowed line to issue the execution command). Because the central dispatching station of the Beijing-Tianjin-Tangshan Power Network does not require remote control operations, therefore only a remote adjustment value setting console is used, i.e., a frequency modulation control console. The console provides a switch to switchover between manually issuing commands and automatically issuing commands (computer).

(c) LFC commands issued by the analog computing device

The analog computing device performs one sampling and computing operation a second. The proportional adjustment signal $k\Delta f + \Delta p$ and the incremental rate

signal $s \int_0^t (k\Delta f + \Delta p) dt$ are sent to the remote control and remote adjustment

transmitter. The frequency modulation control console has an analog computing device connected to the control switch of the remote control and remote adjustment transmitter. When in the input position, the analog computing device performs the LFC command sending task.

When the analog computing device issues commands, actually, the control and adjustment transmitter opens the multiplex switch in cycles, and sends the

three digit BCD codes and their sign digit of $k\Delta f + \Delta p$ and $s \int_0^t (k\Delta f + \Delta p) dt$.

from the analog computing device to all the AGC command receiving circuits at the power station. Then, after digital-analog conversion, the codes are sent to the AGC command receiving circuits of each generator. After multiplying by appropriate amplification coefficients (for proportional adjustment signals, they are determined by the regulatory characteristics of the generators; for incremental rate signals, they are determined by the slope of the broken lines), they are combined with the fixed output value given by the computer or manually established to form a combined numerical value for EDC and LFC and the output is sent to the power regulator of the generator.

The method of issuing commands by the analog computing device is to issue two commands to each power plant. The first time, the proportional adjustment signal $k\Delta f + \Delta p$ is issued. The second time, the incremental rate signal

$s \int_0^t (k\Delta f + \Delta p) dt$ is issued. When the rate of transmission of information at the time of issuing the commands is 200 baut, the two operations require a total of 0.8 seconds. The Beijing-Tianjin-Tangshan Power Network has a total of 7 frequency modulation plants. Therefore, one cycle requires a total of 5.6 seconds. When the rate of transmission is 300 baut, the cycle time is 3.8 seconds. The output of the time difference (ΔT) of the analog computing device is displayed on the screen of the frequency modulation control console. The fixed value P_0 of the communications line is also set on the frequency modulation control console.

(d) The format for issuing remote control and remote adjustment commands

The remote control and remote adjustment device is a star-shaped structure with a channel switchover type 1:n structure. In the CAS system we studied for the Beijing-Tianjin-Tangshan Power Network, $n=15$, but during the design, we were prepared to expand it to 31. One command consists of two words. The first is a synchronous word, the second is an object word. In remote control operations, information for the action of the object relay must be sent back via the SZY-30 remote telecommunications and remote testing transmitter. After checking that it is correct, execution commands are issued automatically or manually.

When performing remote adjustment operations, commands are executed together. Each word has 28 bits. The information format of the synchronous word and the object word is shown in Figure 8

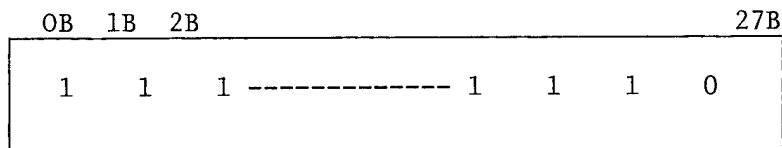

synchronous word format

0 ~ 1B	2 ~ 5 B	6 ~ 17B	18 ~ 27B	
Control and adjustment characteristics	Nature of remote control or number of generator to be remotely adjusted	Number of object to be remotely controlled or adjusted value for remote control	10-digit BCH checking code	4 bit "0"

object word format

We will briefly explain the format of the object word in remote adjustment: In the characteristic digit of remote regulation (OB1B), 01 represents a positive fixed value of remote adjustment, 11 represents a negative value. This is necessary for the LFC signal. The AGC signal receiving circuit of the generator controls the polarity of the proportional adjustment signal or the output of the analog quantity of the increment of the incremental rate. The number of the generator to be remotely regulated has 4 digits, 0000 is not used, thus a total of 15 generator numbers can be decoded, i.e., for each power plant, the active power of a maximum of 15 generators can be regulated. There are 10 supervising digits (18B-27B) of the BCH excess code format. The polynomial generated is $G(x) = x^{10} + x^9 + x^6 + x^5 + x^3 + x^0$ the smallest hamming distance $d_{\text{min}} = 5$.

The rate of information transmission is 200 baut or 300 baut, the channel is an upper sound frequency used repeated.

Here, we need to explain the priorities of the various types of methods of issuing commands. In the CAS system, manually issuing commands and issuing commands by the computer are switched over by a switch and the priorities are both higher than issuing LFC commands by an analog computing device. When the computer performs the EDC command issuing task and the analog computing device is performing the LFC task, then whenever the computer issues a command, the command issuing circuit of the analog computing device is locked and the incremental rate integration circuit is cleared. When the computer has completed issuing commands, the cycle of issuing LFC commands is restored.

IX. Several Problems That Need To Be Explored

The CAS system developed for the Beijing-Tianjin-Tangshan Power Network includes 5 terminals which have passed computer control tests in the laboratory. This system has already been sent to the sites. But there are still some problems that need to be explored further in practice.

(a) The problem of the quality of adjustment in the time shared regulatory system

Because AGC signals are issued and transmitted on a time shared basis in the CAS system, when the computer performs LFC tasks, issuing one cyclic command requires $0.3 \text{ second} \times n$ (n is the number of generators under control). For the 19 generators of the Beijing-Tianjin-Tangshan Power Network, this amounts to a total of 5.7 seconds. This means, the adjustment signal received by the regulatory circuit of the controlled generators is in response to the disturbance signal of several seconds ago. Also, only the sum of the adjustment signals after one cycle equals the disturbance value ΔL , this is equivalent to adding a transfer function in the regulatory system:

$$S(P) = \frac{e}{p} (a_1 + a_2 e^{-2mp} + \dots + a_n e^{-(n-1)mp}) \quad (\text{see appendix}),$$

What limitations does this have on the period of the cycle of issuing commands requires further analysis.

When the analog computing device performs LFC, problems also exist in selecting suitable amplification coefficients for the proportional adjustment signals and the amplification coefficients for the incremental rate signals.

Because of the problems with parameters, we can only give the block diagrams for calculating the quality of regulation and their preliminary derivation in the appendix.

(b) The problem of integration time in the incremental rate circuit in the analog computing device

We should consider how long would integration by the integrator take to reach the full grid value under what frequency difference? This has to be determined in operation and practice by experiment. At present, it has been designed to make ten time adjustments beginning from 32 seconds to 320 seconds under $|\Delta f| = 0.2 \text{ HZ}$. Final determination can be made according to the change in Δf and its duration only after the system has begun operation.

X. Conclusion

The combination of the automatic generation control and remote monitoring and controlling systems for the power network is the trend of development in the automation of power network dispatching. The method of combination explored in this article is relatively simple. The combined digital-analog CAS system built by us and concerned units according to this line of thought is

convenient to realize and is easy to popularize. But this is a new attempt and it needs to be improved further in practice by the Beijing-Tianjin-Tangshan Power Network.

Appendix

Derivation of the transfer function of the time shared command issuing system when the computer performs LFC functions.

When we consider reducing the frequency modulating power plant of the power system to a generator, then the block diagram of the regulatory system can be drawn as follows:

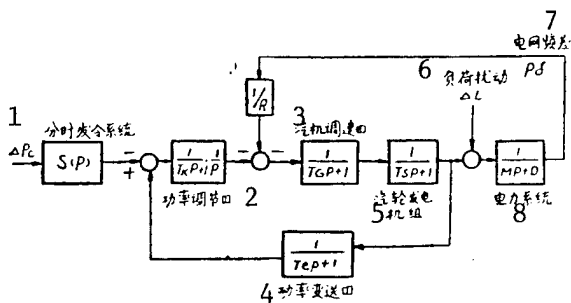

1. Time shared command issuing system
2. Power regulator
3. Steam turbine governor
4. Power transformer and transmitter
5. Steam turbine generator
6. Load disturbance
7. Frequency difference of power network
8. Power system

Block diagram of the regulatory system of the power network (thermal power plant)

$S(P)$ is the transfer function of the time shared command issuing system. Because the computer is aimed at the load disturbance ΔL , after computing $\Delta P_c = \Delta L$, the total gain in output sent on a time shared basis to each of the controlled generator after being latched by the remote adjustment device equals ΔL . Therefore, the output command sent to the equivalent value power adjustment device increases stepwise. According to the stepped Laplace transform and considering the delay time a_0 of the computing process of the computer, $S(P)$ can be written as:

$$S(P) = \frac{e^{-a_0 p}}{p} (a_1 + a_2 e^{-mp} + a_3 e^{-2mp} + \dots + a_n e^{-(n-1)mp})$$

where $a_1 \dots \dots \dots a_n$ are the ratios between the output gain at the time of load disturbance of each generator and the total output gain,

$$\sum_{i=1}^n a_i = 1. \quad = 1.$$

n is the number of generators participating in frequency modulation.

m is the interval of issuing commands by the computer. When transmitting at a rate of 200 baut, $m=0.3$ second in the CAS system developed for the Beijing-Tianjin-Tangshan Power Network.

SOME PROBLEMS OF COMPUTER CONTROL SYSTEMS FOR POWER GRIDS

Nanjing DIANLI XITONG ZIDONGHUA [AUTOMATION OF ELECTRIC POWER SYSTEMS] in Chinese, No 2, Mar 82, pp 17-21

[Article by Liu Jue [0491 6030] of the Nanjing Automation Institute of the Electric Power Ministry: "Views on Some Problems Concerning Computer Control Systems for Power Networks"]

[Text] I. Achievements Realized in Computer On-line Monitoring and Control of Our Nation's Power Networks

Our nation's power systems have been using computers for many years. Most of the power networks above the provincial level are equipped with off-line computers and there are also many on-line computers for monitoring and control. The on-line computers for monitoring and control have been operating for over three years in the Beijing-Tianjin-Tangshan Power Network. The first phase on-line safety monitoring function of the East China Power Network has been evaluated and approved. The on-line monitoring and control system for the Northeast Power Network has recently begun operation. Some provincial power networks have begun to use on-line computer systems, some others have improved off-line computers used in the past for on-line information input to display on screen the real time status of the power network and have preliminarily realized complete monitoring functions. Some power networks have connected on-line computers and off-line computers, utilized the stronger computational function of off-line computers and the available capacity of off-line computers which do not have sufficient tasks to preliminarily realize the function of on-line load forecasting for the power network.

Our nation also introduced two sets of relatively complete computer monitoring and control systems for power networks, i.e., the Japanese H-80E system of the Communications Bureau of the Electric Power Ministry and the Swedish C-7830 computer system of the Central China and Hubei Bureau of Power Administration. These two sets of computer systems have relatively complete hardware and software accessories. Some experiences are also worth learning by colleagues in our nation.

*This article was received in September 1981

In general, at present, many power networks above the provincial level have computer monitoring and control systems. Color screen display has been popularized, adding new means for power network dispatching. Viewing the actual achievements in the operation of the Beijing-Tianjin-Tangshan Power Network, domestically manufactured computers can satisfy the requirements for on-line operation if they are well maintained. The average rate of utilization is above 98 percent. It is expected that the rate of utilization of dual computer systems after their completion can reach over 99 percent. In actual results of operation, as long as there are channels, as long as telemechanic information is relatively complete, as long as telemechanic interfaces can satisfy the requirements, the completion of on-line monitoring-screen display functions will visibly increase the level of safe operation. The dispatchers of the Beijing-Tianjin-Tangshan Power Network already feel that they cannot do without on-screen information. When the computer room makes a request to shut down the computer for inspection and repairs or when transferring programs, dispatchers often hope that the computers could be shut down at another time. The screen can reflect on-site information changes at any moment. This has served greatly in allowing the dispatcher to grasp the immediate situation in time and to handle abnormal situations in the power network. This attracts the attention of the dispatcher more than information sent by the telemechanic devices alone to the console, and this helps him make faster judgements. This cannot be replaced by other means.

Generally speaking, we have realized a lot of achievements. To further popularize the application of the computer in power network dispatching, we believe the following problems still need to be conscientiously discussed to gain a unified understanding and to take effective measures so that it will be easier to realize greater achievements.

II. Understanding Automation

At present, we cannot say that people in various sectors in our nation have a consistent understanding of automation. In the automation of power networks, it is necessary to conscientiously explore what is the "suitable technology" for our nation's present situation. Blindly pursuing advanced technology and importing foreign models are a mistake, but the view that emphasizes our nation's large population, the many problems of unemployment, the fact that our nation is poor at present and it is not the time to popularize the application of computers is also harmful.

A computer system is not only a high-speed computational tool, it is foremost an information processing system. Some people have pointed out that modern production tools can be basically divided into three major categories: machines (machine tools, textile machines), power machines (generators, steam boilers) and information machines. Information machines are centered around computers, including the acquisition, transmission, storage and processing of information. They are called information processing systems. Now, as technology progresses, information processing technology has penetrated and combined with other production tools day by day, and at the same time, it has penetrated management. Modern management cannot be said to be true management if it is separated from information processing technology. Some people abroad say that centralization of information and distributed control are the current direction. There are definite reasons for this.

The dispatching center of a power system itself is an information processing center. It is an agency that makes judgement, decisions and commands according to the current state of operation and the forecasted change in the power network. As the degree of complexity of the power network increases, relying on the telephone alone to carry out dispatching obviously cannot satisfy the demands. The main means of dispatching in our nation at present is based on telemechanic equipment assisted by the telephone. As the degree of complexity of operation increases, as the amount of information increases, it is very difficult for dispatchers to make timely and correct judgements. Some people abroad even say that when the amount of information reaches a definite degree, the information will hinder him in making decisions rather than helping him in the course of processing, or the information will confuse him. But artificially reducing the amount of information will cause him to make wrong decisions. Therefore, when the power network technology develops to a definite degree, introduction of the computer is a necessary trend. Only the introduction of the computer can make possible the other important function of controlling the power network--safety control. T.E. Dyliaco once said: The difference between modern power network dispatching and traditional power network dispatching is whether there are the various functions of safety control. It is because of the requirements of this factor for real time data and the amount of information to be processed that fundamental changes have been brought about in the design of computer systems and man-machine systems.

Our nation's present computer systems to control power networks have realized in general only the preliminary functions--i.e., the functions of monitoring the status of the power network and display. There is still a long distance from the requirements of safety control and economical control. Even so, we have already seen the strong life force of computer control of power networks. The efforts spent over these several years are entirely worthwhile. We can say: The computer of the power network is no longer a thing that may or may not be necessary. It should be an indispensable condition like the communications system and the telemechanic system of the power network. We suggest the leading departments establish necessary technical policies and it would be best to write them into laws or regulations, this means, stipulating the minimum automated functions that a power network dispatching station of a certain level and certain scale should have. Investment in the automation of dispatching stations should occupy a definite proportion in the construction of power lines and substations. Of course, at present, the nation is in a period of readjustment, there is difficulty with capital, and it is not possible to do too much at once. But we should draw up unified plans under conditions of limited capital, and solve the problems of equipping each network in phases and in batches. To do this, the leadership at each level and the management departments must unify their understanding of automation and exert efforts to grasp it before it is possible to realize.

III. Planning and Design Problems

To grasp automation of power networks well, we must first grasp the planning of the automated system and engineering design. In these regards, foreign experience is worth our attention. The course of realizing automation of the power network by the Quebec Hydroelectricity Bureau in Canada spent a total of 10 years from formulating ideas to making them a reality. We can see their

time distribution: It spent more than a year studying the future method of operation of this power network and its automation, and making suggestions on the fundamental requirements of the dispatchers and on how to satisfy these requirements. Then, it carried out preliminary designs. It took three years for the designs to be drawn and win approval.

Then, more than two years were spent preparing bidding and technical documents and bidding and signing the contracts. The time between signing the contracts by the manufacturers and delivering the equipment lasted three years. The time between test runs and final operation took one year. Of course, this system was large, including whole sets of automation equipment of one central dispatching station and 7 regional dispatching stations, all newly built. The dispatching center being used at present will be replaced by a new dispatching center. Although the above example is relatively far from our efforts, and we cannot carry out automation projects of such a large investment at present, but we can see one point here, that is, their work of the early stage took up 60 percent to 70 percent of the total time while manufacturing equipment and test runs took only 30 to 40 percent of the time. Our situation is the opposite. The work of the early stage was done roughly and the time was short. Some problems lacked overall design considerations, we were more anxious in purchasing actual equipment, and because there are many types of automation systems and equipment, and because they come from different manufacturing sectors, frequently the user has to make the interfaces himself, write his own programs, and even write his own software such as the operating system or make improvements. Thus, although the equipment has been delivered, it is incomplete, and the equipment cannot work in coordination, or the software is incomplete, and the functions cannot be performed. As time passes, the equipment can only be displayed and it cannot develop practical results. The beginning hopes have been deflated, and the equipment now becomes the material of criticism by those who oppose automation or people who do not understand automation. This is not a unique case. Even units that have done well have encountered difficulty in further development after one piece of equipment had begun operating and had realized practical results because of the lack of strict engineering design at the beginning. Although a lot of work has been done in theory for new functions, it is difficult for them to be quickly utilized.

There are historical reasons for the above situation. At the beginning, we did not have practical experience in systems automation. We were in a stage of scientific research and in the test point stage. We could only carry out the projects one by one, and equipment was difficult to purchase, and there were no units that could contract the work of the whole project. The users had to put everything together piece by piece. Computer manufacturing departments did not develop user programs, and even systems software was very incomplete, or it could not meet the user's requirements, therefore it had to be changed.

The capital for automation had to be solicited from various channels, and it would be canceled if the project was overdue. Therefore, it was not possible to have a lot of time to carry out work of the early stage. Also, because of the many changes in the elements of the plans, too many details were considered at the beginning and frequently they could not be realized, therefore, plans and designs were not given sufficient attention, the designs did not have any

legally stipulated results, and one could only take one step at a time and long range considerations were lacking.

At present, power network control technology has gradually advanced from scientific research towards practical use. When considering building an automated system for the dispatching center of power networks, we should first do the design work of the early stage well. The user should invest a lot of effort. Now, manufacturers or engineering companies of other sectors have indicated they can contract the entire automation project for the power system. This enthusiasm is good, but frequently it underestimates the complexity of the entire project, because automation of power systems after all involves a broad scope, professionalism is very strong, and there is yet no concrete practical experience in building one project for the external system. Abroad, some manufacturers or engineering companies can contract all the engineering work, but they have a long history of experience in producing power equipment, they are more familiar with the power systems themselves, and there are many experts in power systems, even so, the power companies themselves, as users, must also do a lot of work in the entire process. They must completely understand the situation of their own systems, propose the functional requirements for their own systems by combining with reality, they must select various related subsystems, such as data gathering systems, preprocessing computer systems, main-frame computer systems, man-machine interface systems, software functions, etc., they must establish well detailed technical conditions, and conduct detailed inspection in the future design process, and test and approve all system interfaces and the scope of all detailed designs. Besides inspecting the accuracy of the design in the stipulated functions, the methods of testing and inspection, maintenance of performance and considerations of future needs for development should also be included. There is a lot of work.

Considering the actual situation in our nation at present, there is a definite difficulty for every power administration bureau to invest such huge efforts, therefore, scientific research and design units of the departments of electric power should gradually form forces that can carry out the task of automating the power system by themselves. In fact, they are equivalent to an automation engineering company or a technical service company. They should have a definite strength to develop equipment to solve some special needs, and more importantly, they should have a definite degree of understanding of the power system itself and the various types of automation equipment, and they should be able to provide technical consultation or services to the users, select appropriate equipment for a certain automation project, build the system, match the interfaces, and carry out the task of developing major applications software. In this way, we can more quickly accumulate experience and provide high quality technical services to the users. Such work is part of scientific research but it is not entirely scientific research. More importantly, it is engineering practice. Their achievements are not manifested mainly in developing some new method (of course work in this aspect is not shunned), but in how to apply their own mature equipment and methods in the actual power system so that practical results can be realized. We believe this method of work can promote progress in the automation of power networks.

IV. Near-Term Goals

In view of the present situation, the monitoring function of the computer system of power networks has already entered the practical stage and the results are good. But after all, these are still preliminary functions. To truly develop the effects of the computer system, a lot of work still has to be done.

First, the foundations for communications and telemechanics must be grasped well with a lot of effort. Some power networks cannot develop the function of the computer system because telemechanic information is incomplete. In large inter-provincial power networks, how to form a stratified and graded management system for the information network has become an urgent task. Plans should be conscientiously drawn up well. New varieties of telemechanic devices should also be produced to adapt to this requirement. The pure CDT method can no longer satisfy the requirements. Artificially intelligent telemechanic devices based on the microcomputer will be utilized more. Network structure will also develop from the pure dot to dot method to more complex methods to fully utilize the communications channels (such as coaxial lines, exchange networks, star networks). The standardization of the format of telemechanic data transmission has already been included in the daily agenda. The standards proposed by the Huangshan Conference in the past have served greatly. But it is feared that they will not satisfy future requirements. If we do not grasp this in time, an unavoidable consequence will be that the devices will not have a common language, the interfaces will be complex, and they will not facilitate development. Our institute has proposed a draft of the preliminary standards based on preliminary suggestions made by IEC and we have requested concerned units to discuss it. Data communications between computers of corresponding levels will also be used in certain power systems. The communications protocol should also be included in standardization as early as possible. At the same time, we should stipulate the function and the limits on the division of work for computer communications networks and telemechanic information networks.

To further develop the function of the computer system in power networks, each unit is doing a lot of work. More theoretical and experimental work has been done in status derivation and important achievements have been made. It is hoped that they can be put to practical use as quickly as possible. First, we should establish a real time data bank that has been status derived. Then the functions related to on-line tidal flow, safety analysis, accident prediction and improvement of system safety can be matched on this basis. As we emphasize energy conservation, the economical operation of power networks will surely be pushed forward with a lot of effort. There are also many new theoretical achievements in this regard which can be utilized. Automatic frequency regulation should be one of the basic functions of the computer system. But considering that the operating cycle is relatively short (several seconds) and the high requirement for reliability, under present conditions, it seems better to establish another independent subsystem. The subsystem can be varied so that microprocessor systems can be broadly utilized. (Especially after the 16-bit high performance microprocessor appeared on the market).

Another important function is the recording and statistical function. They are very incomplete at present, and they have not functioned as they should have. Although there are no theoretical difficulties in these functions and they can greatly serve to improve the level of operations management, but at present, they are incomplete perhaps mainly because the capacity of the computers is insufficient, or the information is incomplete or maybe they are not emphasized enough. In general, such functions should be placed at an important position in the next phase of work to develop their potential.

To do all these well, hardware support of presently available systems may be insufficient. In particular, internal memory and the capacity of external memory are weak links. Planning and design must be conscientiously done well to propose solutions.

V. Some Problems Concerning Computer Systems

At present, the several large power networks use different types of computers, but they can satisfactorily perform the current functions of monitoring and display. It is difficult to propose any requirements to unify them because of the difference in the scale of the systems and the difference in functions. The requirements for computers for ordinary dispatching centers (of a capacity of over 5 million kilowatts) proposed abroad at present can be generally summarized as follows:

--the dispatching station itself usually utilizes a bi-level (i.e., with pre-setting) double work system connected to the computer center.

--the speed should be guaranteed at 2 to 2.5 seconds so that all on-line data of the system can be scanned and inspected once.

--the expandability of the memory at least should reach 64 to 128K (16 bits).

--floating point hardware.

--quick response to interrupt functions.

--restart according to internal or external signals after the computer has been shut down as a result of malfunction.

--internal memory protection function.

--repeat execution function after detecting malfunction (can be accomplished by software).

--external memory capacity should at least be over 2000K (actually far surpassing this number), and there should be two types of external storage. One type is the magnetic drum of fixed head magnetic disk to store information that requires a faster storage and access speed. The other type is the moveable head magnetic disk to store information that has a lower frequency of use and that can respond at a slower speed.

In view of the above requirements, the main conflict of domestically produced computers already in use is that the internal and external memory capacity is small. Each unit is developing new high performance domestically produced computers. They can continuously enter the market. It is believed that the hardware can gradually adapt to the needs of the power network in the future. When gradually expanding the functions of currently available computer systems, currently available computers can be used as front-end terminals. Some systems are considering this. But we must conscientiously consider the plans for related interfaces when realizing this. Most of the provincial power networks in our nation are equipped with off-line computers. To fully develop the function of off-line computers, some power networks have already used them as backup for on-line computers and good results have been achieved. It is suggested that concerned manufacturers also summarize this experience and directly produce such hardware and software interfaces for the user to facilitate popularization so that more can be done with less money.

The double computer system as a means to improve the utilization rate of computers will be used by many power networks. It is suggested that manufacturers and users strengthen research in some of the problems such as plans for operation, function sharing, switchover methods, software support so that the dual computer system can fully develop its gain. Computer manufacturers can only provide some standard hardware accessories. Solving the mutual relationship between the software of dual computers and the mutual relationship between the operating systems is frequently more complicated than hardware, and according to different user requirements, frequently the interface between the software and the operating system will be affected. This is a very important content in systems design. It can be done well only by full cooperation between the user and the manufacturer. There are such reports abroad: "The typical configuration of the computer manufacturer cannot completely satisfy user requirements, and this frequently occurs. For example, the power system requires safety control functions and data gathering that include status estimation. AGC and man-machine links have the same usefulness, but in practice, they have been reduced to non-key functions and they do not meet the initial requirements, therefore the responsible power engineer is very worried." This should not be neglected in considering plans for the dual computer system.

Some of the real time operating systems of domestically manufactured computers at present are directly transplanted from abroad, some have been the result of rebuilding the computer on the foundation provided by the manufacturers, or some have been developed by oneself, but in general, they can all satisfy the basic needs in operation. When evaluating an operating system, we should not unilaterally pursue the perfection of the functions or the advanced nature of one item. We should first consider real time requirements. We cannot spend too much and thus reduce the response characteristics of the entire system. Therefore, some characteristics that are effective in general purpose computers such as internal dynamic distribution and the use of virtual memory need not be overly pursued in control mechanisms. We should decide whether they are needed or not based entirely on the concrete requirements of the system itself. Management of the data bank should also suit the requirements of real time data processing. It should not be overly complicated and versatile. In addition, in the course of linked computer operations, developing

programs is not a simple question. On the surface, developing programs can be via the management of backup operations to reduce on-line interference, but there will always be some on-line functions that cannot be completely simulated or debugged in backup. Therefore after the backup has been debugged and goes into front-end operation, a slight carelessness may produce destructive results. For this, we must take special measures to prevent such happenings. These are not necessarily included in the functions of standard operating systems. We need to cooperate with the manufacturers to find a plan for solution.

Screen display has already been widely utilized in our nation. We can say that the reason that computer monitoring and control are welcomed by dispatchers is because the use of color CRT has served a major function. There are many units that are currently producing and developing CRT. We believe the light grid scanning dot matrix CRT can satisfy the needs of the power system for a time in the future because it is low cost and software support is relatively easy. Other more complex graphic displays can suit some special needs. The next step should be to utilize higher density image tubes on the present foundation, expand the types of Chinese characters and graphs, and perfect the tracer, the photopen or keyboard accessories. Some other editing functions should be considered without overly increasing the cost. The function of moving graphs is welcomed by users, but in use, this function occupies more of the computer's load and internal and external memory and such resources, and when it is not absolutely necessary, it should not be overly pursued. The total number of graphs of currently operating systems is not large, and the response time does not seem to have any problems, but as the number of graphs increase (such as 100 to 200 or more graphs), editing, revising and accessing graphs must utilize external memory. The response time will be visibly increased, and if it reaches more than 4 to 5 seconds, then it would be intolerable. Now, domestic computer manufacturers still have not equipped their products with a CRT management program suitable for use by power systems. It mainly relies on the user to develop it himself. If users can be organized to combine several computer models to develop some standard CRT management software, then a major convenience can be realized for future users.

VI. The Problem Concerning Software

Software has always been a weak link. The traditional inability of domestic manufacturers to provide applications programs has increased the burden of the user. In general, after a computer is purchased, the user must organize a lot of manpower and invest it into programming. If the strength is insufficient, the user can only compile a little at a time and the gain of the system cannot be developed very well. Some service software of some domestic computers (also called practical software) have insufficient functions and this has brought about many difficulties in developing programs.

In the course of writing software, analysis and design stages should be the most important stages. From the beginning, the state should stipulate the models for various programs, input, output, tables, revision of tables and method of computation. The design plan is determined by the structure of the data and the method of storage and access, the structure of the tables and

documents, the requirements of data revision, and reserve requirements. All hardware and software interfaces should be labeled in detail. Regulations should also be stipulated for others such as initialization procedures, CRT and printout record formats, maintenance requirements, testing methods and inspection standards. This work is often not emphasized enough domestically and the work is very generalized. The computers lack explanatory documents, and thus later the systems become confused, and finally readability of the programs and maintainability are affected. A program written by one person is frequently difficult to revise by others later or it is difficult to add some other functions to the program. In the future, scientific management of the method of software engineering should be popularized.

To hasten the progress in program design, it is suggested that specialized program design teams be organized to develop some applications software packages suitable for use on various types of computers. For example, the BBC company has applications software packages aimed at power systems of various scales. They have such basic functions as data gathering, data bank organization and output display. Hardware and software are configured for such systems as the BECOS 03-30 which is suitable for small scale centralized control systems and for large scale centralized regulation systems. The user can select the system that suits him.

To solve the problems of exchange and transplanting of programs for different computer models, it is suggested that some programs with more complex methods of computation should be written in high level languages as much as possible.

Some years ago, most of the on-line control programs abroad were written in compiler languages. But in recent years, the proportion of using high level languages has greatly increased. Viewing the trend, FORTRAN or variations of FORTRAN that have real time functions is still the most widely used language. In consideration of the fact that domestic computer language systems are also being prepared, we should consider whether we can unify them on the foundation of FORTRAN as much as possible so that some programs can be easily exchanged and transplanted. It is suggested that some units organize and establish joint working groups to coordinate and exchange programs well. Of course, transplanting programs should be rewarded to encourage the enthusiasm of program writing units.

The above are some views concerning the problems of computer systems for power network control. They may very well be unilateral or even mistaken. It is hoped that they will attract the interest of concerned sectors to discuss, to draw conclusions and to propose some practical and feasible measures. Then the power network control technology will suit the development of the power networks much better.

9296
CSO: 4013/140

DISPATCHING AUTOMATION FOR EAST CHINA GRID

Nanjing DIANLI XITONG ZIDONGHUA [AUTOMATION OF ELECTRIC POWER SYSTEMS] in Chinese, No 2, Mar 82, pp 22-30 and 21

[Article by Xu Desen (1776 1795 2773)]

[Excerpts] I. History and General Situation

The "automated dispatching plan for the East China Grid" drawn up in 1976 called for the establishment of an independent and reliable system of channels that can satisfy the demands of automation of dispatching for the power network and that can perform telekinetic functions to control power plants and power stations. The plan also called for the establishment of an information gathering system for the power network and a computerized real-time data processing system. The goal was to gradually establish a computerized digital transmission network and to establish such automatic control functions as safety monitoring, safety analysis, economical dispatching, frequency modulation and voltage modulation for the power grid in stages.

The East China power grid is divided into three dispatching levels, a central dispatching station, a provincial (or city dispatching station where the central dispatching station is located) and a prefecture dispatching station. Their relationship in the future is illustrated as follows:

Because the area is expansive, the fundamental work to establish the channels and information gathering is more difficult. Besides the original carrier wave circuits, sound frequency cables and channels leased by the post and telecommunications sector, we have installed 106 kilometers of sound frequency cables in the Shanghai area, 46 kilometers of sound frequency cables in the Shanghai area, 46 kilometers of a high frequency cable from Xijiao to Huangdu, 66 kilometers of a microwave circuit in suburban Shanghai, and 547 kilometers of microwave circuits from Shanghai to Hefei over the past few years. Those being built and in preparation are the microwave circuit in the Shanghai suburbs, and the microwave circuits from Hefei to the north of the Huai River, from Shanghai to Xuzhou, and from Shanghai to Wuxijiang. At present, all of the provincial (municipal) dispatching stations and power plants and stations directly dispatched by the central dispatching station have to varying degrees been equipped with channels needed for communications and transmission of telekinetic information. In the Shanghai area, the sound frequency cable and the suburban microwave circuit will gradually form a ring grid.

II. Characteristics and Evaluation of the System

1. The programmed command type telekinetic equipment is connected to the computer in a versatile manner. Its adaptability is strong. For example, remote testing of cycles was changed from the original 3 bits to 4 bits, 18 commands were changed, the upper and lower voltage limits were changed, 19 commands were revised,.....These have provided convenience for the computer interface and software processing, simplified the programs for the computer processing system of computers with limited speeds and conserved memory units.
2. The performance of the computer system is checked via many parallel channels and an automatic restoring system has been added. This has improved the reliability of the real time system.
3. Completion of the DJS131/TQ-16 on-line system provided the possibility for running one-line scientific analysis programs, and on the basis of improving the reliability of the TQ-16 computer, different tasks with a relatively high requirement for precision have been run using different programs. This has created conditions for further developing the functions of the system.
4. The operating system provided by the 100 series computers is more mature, it is more convenient to use and it is more versatile. The application software is closely combined with the actual needs in dispatching, and the operators are happy to use it.

In November 1979, the 220KV gate of the waterside power line malfunctioned and caused interruptions in the power grid twice.

The telekinetic equipment acted accurately and won time for the dispatchers to rapidly judge the situation and to handle the situation in time. The voltage and cycles of the small system were kept normal and the occurrence of a power blackout over a large area was avoided. In January, 1980, the 220KV output line voltage of a certain power plant changed, causing 13 220KV switches to jump the gate. Telekinesis completely recorded the time when the switches jumped the gate and the tidal current of the incident, (the resolution of the time of the switch action was 20 ms), the color CRT displayed the central parameters of the plant in time and completely reflected the operating condition during the incident at the power plant and during the course of processing. This facilitated handling of the incident and served monitoring and guiding functions.

"Secondary on-line" load estimates are provided four times a day. When weather and climatic conditions suddenly change, generally, all of the errors are within the allowable range. This also helps to guide the personnel on duty to grasp the load patterns of the system.

The channels and telekinesis of the East China power network have a weak foundation. The computer system also needs to be further perfected. There are still many difficult tasks to be done.

III. Prospect

The purpose of automation of dispatching for a power system is to effectively increase the managerial and operating level of the dispatchers on duty so that the power network can operate safely and economically at any time and provide superior quality electric power. Within the next few years, new localities of power source and power transmission lines with an even higher voltage class will emerge in the East China network. The technical problems of operating the network will be more complex. Even higher demands will be placed on automated operation. Our purpose is to develop the capability to perform on-line safety analysis of a static system from the present stage of "monitoring safety" and to develop to varying degrees the ability to realize economical dispatching, anticipation of accidents, display of countermeasures and automatic frequency modulation. Voltage modulation will also be developed so that we can conduct local automatic control tests at places such as hydroelectric power plants where the strength of automation is stronger. To achieve this goal we must adhere to the following:

1. We must establish a relatively perfect microwave system as the main system and a carrier wave system as the auxiliary system in the main network. The regions where a dispatching station has been established must lay a system of channels consisting of ground cables, carrier wave channels and microwave channels. The error code rate of the channels should reach a magnitude of 10^{-7} .
2. We must establish an information gathering system that is suitable for uniform dispatching and split level management. The principles of installation of telekinetic equipment and the type of control must adhere to the setup illustrated in Diagram 12.
3. We must set up a computerized digital transmission and communication network using the same model of computers, and we must set up a multiple unit processing system that meets the demands of dispatching duties so that the system can have a better adaptability and usability, so that the system can react well after a definite period when the equipment is down-graded or so that the system can react well to compatibility when the software and the hardware change in generation. Undoubtedly, the idea of using computers of a single model is reasonable in developing the functions of software and hardware resources and concentrating efforts to develop software and hardware applications systems that suit the unique characteristics of this power system so that it can quickly form a productive force. This is also suitable for the East China power network.

The 100 series computers used by the East China power network at present have their international counterparts that are being rapidly developed, such as the ECLIPSE, the MV-8000 which are high grade computers of this type. The command system and the systems software are completely compatible. The domestically manufactured DJS-140 computer (64K to 128K) has already began production. The software system of that computer system is relatively complete and it is equipped with real time high level languages. This is also a favorable condition for the development of the system. From the viewpoint of technical and economic comparison and the rationality of the system, I believe that it

is possible that a system similar to Britain's CEGB system will emerge in the future which will move the massive on-line applications, scientific management software development tasks and computational tasks of the control center to the computational center of the electric power research departments.

The development of on-line applications programs for the power system is relatively difficult and it requires the support of advanced hardware systems. Foreign nations have invested a lot of "man-years" in such endeavors. The East China power network has organized concerned higher educational institutions, schools and scientific research units in 1978 to do some work in this regard with help from the Ministry of Electric Power and the Shanghai Municipal Science Committee. In general, the subjects have been the following:

- * Estimation of the on-line status of the power system;
Recognition of the on-line network structure of the power system;
- * On-line load estimation of the power system;
- * Safety analysis of the on-line stationary state of the power system;
- * On-line economical dispatching (local) of the power system;
- * Study of the on-line data bank of the power system.

According to plans set for the next 2 to 3 years, we will collect about 1,000 parameters related to the main network. The number of DJS-131 computers has already been increased to 3 units equipped with magnetic disks. They use the digital transmission type telekinetic interface JK₂. On this basis, the "on-line safety monitoring" function will be expanded and strengthened. A man-machine conversation system equipped with a photopen and a tracking ball will be used. On-line economical dispatching tasks will be performed on the second DJS-131 computer, (in the near-term, it is only an open loop type, commands are manually produced). The DJS-131/TQ-16 on-line computer system will be used for daily scheduling of dispatches and will perform safety analysis tests. The 100 series digital transmission and communication controller will be used at test points to test the performance of the digital transmission network. The rough idea described above still has to be proven and to materialize in future planning and designs.

IV. Conclusion

The work to automate dispatching in the East China power network is only a beginning. Construction of this system involves a broad scope, its policy nature is strong and its investment is large. Each step presents a problem of connecting the preceding with the following. Planning first is very important. On the other hand, because the foundation is poor and the technical forces are weak, the forces of the various sectors must be organized well and joined together to carry out the work. The central dispatching station of East China received indispensable help from the Electric Power Sciences Academy, the Nanjing Automation Institute, the East China Electric Power Experimental Research Institute, the East China Electric Power Design Academy, sister power networks and concerned higher educational institutions and manufacturing plants from planning to the present. We appreciate their help.

EXPERIENCE WITH ON-LINE OPERATION OF A POWER NETWORK COMPUTER REVIEWED

Nanjing DIANLI XITONG ZIDONGHUA [AUTOMATION OF ELECTRIC POWER SYSTEMS] in Chinese, No 2, Mar 82, pp 31-33

[Article by Chai Yuhe [2693 3768 0735] of the Automation Department of the Central Dispatching Station of the North China Bureau of Power Administration: "Some Experience With the On-line Computer of the Beijing Power Network"]

[Text] The SD-176 computer has been operating on-line for three years now. The Beijing Dispatching Center and the Nanjing Automation Research Institute have cooperated closely, conducted mutual exchange, and the on-line operation of the computer has progressed steadily. Three years ago, our goal was reliability and practical results. Reliability meant that the hardware of the SD-176 computer would operate steadily and the software designs would be correct. Practical results meant that the SD-176 computer could truly serve safety monitoring functions. Now it seems that these two goals have basically been realized.

The guiding thought in our work was that after using a computer for on-line monitoring functions, it must withstand objective tests and truly develop this function. On the originally available monitoring function, we added 327 new switching functions in the monitoring function of the SD-176 computer in 1980. After these functions began operation, the Department of Automation established corresponding systems to guarantee that these functions were realized. At the end of that year, when the results of these functions were evaluated, the Dispatching Department and the dispatchers gave them an affirmative evaluation.

Computer on-line operation is a very difficult task. We must be extremely serious and conscientious in treating this work.

I. The Foundation of On-line Operation of the Telemechanic--Power Network Computer

I believe that we must first do the work of telemechanics of the power network well before we can realize on-line computer operation in a power network.

The SD-176 computer of the Beijing Central Dispatching Station has been connected to more than 20 telemechanic devices. (Recently, after the telemechanic interface is expanded, another 5 devices can be connected) and it can perform

*This article was received in September, 1981.

on-line processing of over 700 remote communications and remote measurements. In 1979 alone, 7 telemechanic devices were installed and over 100 remote measurements could be taken. In 1980, another 87 measuring points were added. This year, the higher authorities have asked for nearly 100 additional measuring points. Starting out from the point of view of computer on-line operation, the demands upon the telemechanic devices are even higher. To monitor the operation of the power network, we should input a large amount of real time information into the computer but the information put into the computer should be accurate and reliable.

After a large amount of real time information has been put into the on-line computer, the first problem that software personnel encounter in designing the safety monitoring program is the problem of processing real time information of checking and measurement. Viewing our several years of experience, the key is to build the telemechanic devices themselves well. Song Deyun [1345 1795 0061], former assistant chief engineer of the Beijing Dispatching Center talked about this after returning from the large power network conference last year: When some people abroad talk about on-line operation of computers in a power network, they place a lot of emphasis on the reliability and accuracy of telemechanic devices themselves. In remote measurements before installation of the SD-176, the dispatchers of the Beijing Dispatching Center sat in front of a remote measuring console. This remote measurement console displayed the total power of each power plant and the boundary points between the 220,000 and 110,000 power plants. For many years, dispatchers and comrades engaged in telemechanics have been debating over whether the remote measurements displayed on the remote measurement console were accurate or whether the meters at the site were accurate.

After the computer began on-line operation, the direct view of the display on screen has helped us to discover this problem quickly: Some of the information of remote measurements sent to the Dispatching Center by the telemechanic devices in the field contained overly large errors when measured by Kirchhoff's law. For example, in our network, a certain 220,000 substation has installed a WYZ-II telemechanic device. This substation has two 220,000 output lines and one 220,000 transformer. Under certain operating methods, the two lines can both send power to the transformer. Then according to Kirchhoff's law, the active values flowing into the two lines should be equal to the active values flowing to the transformer. But in the actual situation, the inward flow was far greater than the outward flow. This showed that remote measurements of this telemechanic device were very inaccurate. We once spent five months to calibrate more than 300 remote measurements at fixed intervals and explored the reliability of each measurement. At the special conference on telemechanics, we repeatedly emphasized that the accuracy of remote measurements of the telemechanic devices already installed at measuring points can be measured by Kirchhoff's law, and we must frequently use this principle to evaluate the power transformer and transmitter and the operation of the telemechanic equipment.

In some power plants, such as the Beijing Second Thermal Power Plant and the Tuhe Power Plant, Kirchhoff's law can still be used to inspect the accuracy of remote measurements of remote measuring devices already installed at these

plants. Tuhe Power Plant does not have a directly distributed load line. The active power of the four generators and six 220,000 output lines can all be remotely measured. The power consumption by the plant constitutes 7 percent of the total output of power by the whole plant. In this way, the generated power minus the power consumed by the plant should approach the active power of the six output lines (neglecting loss in the transformer).

If many of the remote measurements in the power network themselves contain large errors, then we cannot even talk about using status derivation.

We introduced the comparative results of the remote measurements and the typical records of the dispatcher to the Dispatching Department. Finally, on the basis of Kirchhoff's law, we unified understanding and there were no more disagreements.

The monthly operating test system (remote communications) of the telemechanic devices has served well in preventing mistaken operations triggered by remote communications during accidents in the power network.

The SD-176 computer has one function that monitors the current of twelve 220,000 transformers in the network. When the current surpasses the specified value, the screen will display an automatic warning. We have a higher demand for precision of these remote measurements. For example, the main transformer of Gaojing No 4 is an auto-transformer. The common coil current of the auto-transformer will overload under certain operating methods. The specified current of the common coil of the main transformer of Gaojing No 4 is 573 amperes. Because comrades involved in telemechanics at the Gaojing Power Plant conscientiously tested the transformer and transmitter, the difference between the values of remote measurements and the values indicated by the meters at the site was very small, the largest did not surpass 5A, and the measurements have been deeply trusted by the dispatchers. Doing this work well requires spending a lot of efforts. But to establish on-line computer operation firmly, we must tighten the work of telemechanic devices.

II. Operating Rules and System

According to the experience of on-line work of these few years, I believe that domestically manufactured computers can be used to carry out on-line operation. After on-line operation has been established, we must establish various regulations and systems to standardize it.

The Automation Department of the Beijing Central Dispatching Station has established:

1. the operating procedures for the SD-176 computer;
2. the system for computer room shifts and exchange of shifts;
3. the software maintenance system;
4. the system for monthly operating tests of telemechanic devices matched with the computer;

5. the system for examining the accuracy of remote measurements;
6. the system for reading dispatcher records at fixed intervals;
7. the system of submitting notices for remote measurements and remote communications.

I would like to emphasize the last several systems in this discussion. The software maintenance problem should attract our attention. According to foreign reports, among software designers in the world, 70 percent are involved in revising software, and only 30 percent are designing new software. As the on-line monitoring function expands and real time information increases, software must frequently be expanded and revised. The revised text should be handed over to the computer room shift in time so that computer room shift personnel can refer to it. Revised programs must be tested for a period. If omissions are discovered in the programs, the programs must be revised again until they are correct.

Software maintenance in the stage of safety monitoring at the Beijing Central Dispatching Station also includes the compilation of statistics on the percentages of correct action displayed on screen during accidents in the power network. For example: At 11:58 on 12 December 1980, the No 1 generator at the Dagang Power Plant malfunctioned and the switch disconnected. The screen did not display any action. (After the switching monitoring program became operational, switch disconnections occurred many times at the Dagang Power Plant, the screen displays reflected the situations correctly and the program was praised by the dispatchers). Why did it not act this time? Software personnel asked the dispatcher on duty and found out that several hours before, reverse switching operations were performed at Dongbeijiao and Hangu and the computer screen display system reflected the situation correctly. Software personnel grasped this and immediately found the cause and finally discovered that the reason the screen did not reflect the switch disconnection of the No 1 generator at the Dagang Power Plant was not a problem of the computer itself but was caused by the breakdown of the WYZ-II remote measurement code transmitting device at the sending end of the Dagang Power Plant. (When designing the switching program, in order to prevent interference, changes in switching power were added as supplementary judging conditions when the switch was on or off). We understood that the telemechanic personnel at the Dagang Power Plant did not handle the remote measurement code transmitting device well that day, and we immediately revised the program and temporarily deleted the added condition for judgement of power.

Another aspect of the software maintenance system at the Beijing Dispatching Center is that every morning at 10 am, the position of the switches at the power station being monitored by the computer is inspected to see if it corresponds to the position of the switches on the analog console. At present, the SD-176 displays on a color screen the positions of more than 300 switches of 8 major power plants and thirteen 220,000 substations it monitors. Every switch being monitored must be consistent with the analog positions of the switches on the analog console. The results of implementing this system were very good and a lot of experience has been accumulated.

On 13 June 1980, the power line poles of the double circuit 220 KV power line from Tuhe to Tongzhou seriously fell. The screen display system of the SD-176 computer correctly disconnected 4 switches and sent warning messages to the dispatcher. Afterwards, dispatcher Comrade Liu Wende [0491 2429 1795] talked to us. He said: "If the relay protection signal can be displayed during the accident, that would be even better. It will greatly help us in handling the accident in the power network." When we were preparing to test the input of relay protection signals to the telemechanic devices on the WYZ-II device at the Second Beijing Thermal Power Plant, comrades engaged in relay protection proposed different opinions. The on-line "experience" of the computer is still very shallow, and we must respect other people's opinions. But I believe comrades engaged in relay protection will finally agree because it has already been realized abroad.

At the Beijing Dispatching Center, a monthly remote communications and operation test must be conducted to test the telemechanic devices of the telemechanic operations system. This is a good opportunity to test the operation of the computer in monitoring the switches. Therefore, we established an operating system that joins telemechanics and the computer.

Beginning from early last year, we made telemechanic remote measurements every five days and we compared the measurements with the typical records of the Dispatching Department. When we discovered that the remote measurements did not coincide with the stipulated requirements, we immediately notified the telemechanics group to find out the cause. Special personnel from the software group was assigned to take charge of this work.

III. Necessary Conditions in the Computer Room Required by On-line Operation of the Computer

The computer room must possess the following conditions:

1. There must be a source of uninterrupted electricity;
2. Temperature and humidity changes must not surpass a fixed range.
3. There must be measures to prevent dust;
4. There must be fire-proof measures.

The four points above are minimum requirements. But our Beijing Dispatching Center cannot even meet these basic requirements at present. When delegates from the United States, France, Canada visited the computer room of the Beijing Dispatching Center, they unanimously believed that our power source is unreliable. This is a fact. A 220-volt power source supplies power to the computer via a voltage stabilizer. This is too unreliable. I believe that foreign computers in on-line operation will never use this kind of power supply method. Because the low voltage network of the power network cannot operate in parallel, the Beijing Dispatching Center has only one line of power source. When the power source breaks down, the power source is switched over to another reserve line for power supply, but during the time of the breakdown and

switchover, the computer receives a very large shock. To reduce shock, it "registers" with the Beijing Power Supply Bureau. When the Beijing Power Supply Bureau inspects and repairs the power lines, it first notifies us and waits until we shut down the computer, then they perform the switch reversing operation. After the power supply bureau completes its operation, we then turn on our computer again. Before "registering", we suffered a lot of hardships. One day in the summer of 1979, power outage occurred 12 times (the bus of the Youanmen Substation malfunctioned, the Beijing Dispatching Center supplied power via the Qianmen power cable. When the load at Qianmen rose and surpassed the load capability of the cable, Beijing Power Supply Bureau then pulled the switch). That day, the voltage stabilizer of the computer burned out. Luckily, the power switch of the SD-176 computer itself was reliable, otherwise the computer would breakdown.

Beijing has strong winds and a lot of blowing sand. The computer room for the SD-176 computer does not have special dust preventing measures. The inserted boards are filled with dust and operating conditions are extremely poor. We installed a thermostat and air conditioning equipment manufactured in Qiangdao. But in summer, the air conditioner works poorly. In winter, two large electric heaters are placed in the computer room. The SD-176 computer operates under such conditions. It is indeed not easy for the computer to operate at 98 percent capacity. The purpose of mentioning this is to emphasize that the user must create better conditions for on-line computer operation. One must be willing to invest in building a good computer room and one must not make do.

At present, the computer room at the Beijing Dispatching Center will not undergo major changes unless a new building is built for dispatching operations. Therefore, next year, when two computers go into operation, although the situation will be better than the present single computer operation, it will not be possible to greatly improve the operating rate. When the external power source is cut off, three computers will be threatened simultaneously. This is a serious problem that we will face.

IV. Assuring Long Term and Reliable Operation of the External Memory (Magnetic Drum)

The American, T.E. DY. Liacco mentioned in his article "General Description of a Control Center of a Power System": "In actual operating experience, most breakdowns of the computer system can be overcome by simply restarting the computer." According to our experience, his point is correct. Occasional interference (endless looping of the program, odd and even checking errors in the internal memory) can be overcome by restarting or the computer can continue to operate by accessing a copy of the program from the magnetic drum. Without a reliable magnetic drum, the computer will not be able to operate on-line. During operation, the operation of the magnetic drum component must be fully kept in mind. As long as the magnetic drum component does not breakdown, it should always remain in an operating state. During the period of inspection and repair of the mainframe, the magnetic drum should not stop operating. Turning the magnetic drum on and off frequently is very detrimental to the magnetic drum. The magnetic drum must be protected against phase interruption. We have installed an automatic phase interruption warning device on the magnetic drum.

V. Correctly and Rationally Utilize the SDX-II Display

The practice over the past three years at the Beijing Dispatching Center proves that the design of the SDZ-II screen display device is successful. Operational experts of the large Canadian power network pointed at the analog console during their visit and said: "The method of electrical connections and the voltage level in the substation of your power plant are about the same as those in Canada 15 to 20 years ago. But your color screen display is pretty good. Color separation is good and the image is very clear."

There should be special people to maintain the display screen. We must especially emphasize that it should not be moved or adjusted at will. The keyboard should be fixed on the table top.

During the three years of operation, the two display screens of the dispatching station were used alternately every 12 hours. According to experts, using them in this way will not encounter any problems for several years. A fan should be used to dissipate the heat of the screen if the noise of the fan does not affect the work of the dispatchers. The base of the fan should have an anti-earthquake cushion. The computer room must have a reserve keyboard.

9296

CSO: 4013/140

DJS-6 MINICOMPUTER USED IN ON-LINE OPERATION

Nanjing DIANLI XITONG ZIDONGHUA [AUTOMATION OF ELECTRIC POWER SYSTEMS] in Chinese, No 2, Mar 82, pp 34-38

[Article by Yue Zizhong [1471 1311 1813] of the Central Dispatching Station of the Guangxi Power Bureau: "DJS-6 Computer Begins On-line Operation; the Principles of Improving the Mainframe and the Interface Logic of Newly Added Peripherals"]

[Text] The DJS-6 computer is a small digital computer designed during the 1960s. The internal memory is 32K, the word length is 48 bits, the peripherals include 4 G3 drums and it can use magnetic tape and disc drives. It has 62 basic commands. It can send over 100 commands. Commands are divided into two categories, long and short commands. Address location includes direct address, indirect address, relative address, duplex relative address functions. The computational speed is 90,000 commands/second.

The transmission of information by the DJS-6 computer uses the bus. The bus has 25 code lines DX_0 -- DX_{24} . The bus for the address codes has 16 lines dx_1 -- dx_{16} . It can realize parallel transmission of half word length.

The computer at our station began off-line operation in 1974. To improve its rate of utilization, we improved it and added some equipment and it began on-line power network operation at the end of 1979. After two years of test operation, we proved that the improvements were successful. They are briefly described below in the hope that colleagues will point out the mistakes.

I. Improvement of the Mainframe

Improvement of the mainframe mainly involved the interrupt system and the command system.

The interrupt system of this computer originally had two types of four level priority interrupts. The two types refer to the simple interrupt and the program interrupt. The four levels are print and information interrupt in simple interrupt and the internal error and external peripherals interrupt in the program interrupt. The external peripherals interrupt includes teletype, wide line, curve, fast punching. These four interrupts all belong to the same level. Whichever makes the interrupt request first is responded to first and at the same time the other interrupt requests are masked.

The characteristics of simple interrupt: When an interrupt occurs, the computer needs only to execute one implicit interrupt instruction to complete processing the interrupt request, i.e., it is realized entirely by the hardware circuit logic alone. Program interrupt mainly relies on shifting into an interrupt processing program to process it, i.e., the interrupt request is realized basically by the software.

Obviously, the original interrupt system needs to be expanded before it can adapt to the needs for on-line operation. We added four levels of program interrupts of power loss, clock, special communications and screen display (recently, we also added a tabulation and print interrupt), thus forming an interrupt system with 8 levels of priority interrupts. Also, we improved the original implicit interrupt instructions for simple information to adapt to the needs of transmitting telemechanic information in on-line operation. Although the DJS-6 computer is a general purpose digital computer, the original design took into consideration the possibility of using it to process external information in real time. Therefore, a first level simple information interrupt was built into the interrupt system, and an "implicit interrupt instruction for simple information" was designed and included. An implicit instruction refers to an instruction that has an execution process similar to the execution process of a standard machine instruction but it does not have the form of an ordinary instruction. Its operating codes correspond to the controlled electrical potential of different interrupts and its function is completely hidden in the logic of the system of instructions. The execution time of this implicit instruction is a central cycle (about 11 microseconds). Its method of execution is typically cycle stealing. Therefore, we utilized this simple information interrupt to form the data channel for telemechanic information to enter the computer. But the function of the originally designed implicit instruction should not satisfy our actual needs, therefore we improved it. The major change was to bypass the random address memory as the pointer for writing into the address of the internal memory and to directly form the internal address by the telemechanic interface and to send it directly to the internal memory before common operations initialize the internal memory, thus the writing of telemechanic information into the internal memory realizes "seat assignment", completely avoiding chaos.

Because of the newly added peripheral equipment, such as the color CRT, real time clock, tabulating printer, therefore some new commands were added. Among the newly added commands, some were expansions of the original peripheral equipment commands, some were newly defined peripheral commands. The actual functions of the commands will not be discussed here. We will only simply explain the newly added "time check" command and the self-restoring circuit.

The basic starting point of the self-restoring circuit is as follows: When the computer ceases operation because of accidental causes, the computer will not execute the most fundamental fixed-time operated user programs, such as data conversion and clearing the CRT screen. At this time, regardless of whether the computer has ceased operating or is executing another program, the situation is regarded as abnormal and it will have to be restored to normal.

For this, in the self-restoring circuit, we designed a three-digit counter that will overflow when it counts to 7. The counting pulse is the second pulse produced by the clock circuit. The clearing pulse is produced by the "time check" instruction. We arranged that instruction in the user program with an execution cycle of 5 seconds for data processing or for CRT display. In this way, if the system is operating normally, the three-digit counter of the self-restoring circuit will at most be able to count to 5 and it will be cleared. If the system is operating abnormally, then there will not be a clearing pulse, and the counter will produce an overflow. The overflow signal will set the self-restoring circuit, forcing the computer to execute a drum adjustment program pre-queued in the switch memory and the RTOS program copy will be accessed from the external memory and re-run. If the computer breakdown is purely an accidental jump (according to foreign data: accidental breakdowns constitute over 70 percent of all machine breakdowns), then after such procedures, generally the computer will be able to operate normally again. If the breakdown is permanent, then after three consecutive automatic restoring efforts, the alarm circuit is triggered, and the person on duty can interfere. It can be seen that the self-restoring circuit is effective for accidental breakdowns of the computer. Our operation and practice also prove that it can effectively improve the time of continuous operation of the system and reduce the down time.

II. Peripheral Interface Logic

Diagram 1 shows the general block diagram of the peripheral interfaces. The H_1 , H_2 , Y_3 , Y_4 belong to the mainframe, all of the rest are interfaces. It can generally be divided into four parts, the peripheral code bus, clock circuit, telemechanic interface, and CRT interface. They are explained separately below:

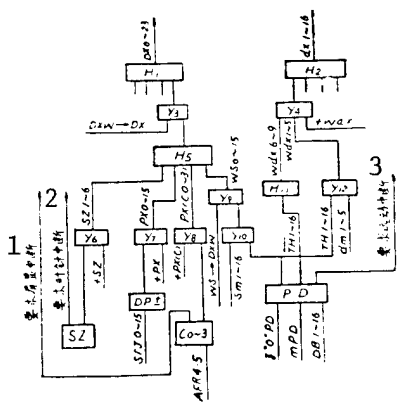

Diagram 1 General Block Diagram of Peripheral Interfaces

- 1 Request screen display interrupt
- 2 Request clock interrupt
- 3 Request telemechanic interrupt

Remark:

H	NOR gate	TH:	Electrical potential of station number
PD	queuing circuit	Y	NAND gate
DP	electrical potential converter circuit	SZ	Real time clock circuit
H_1	code bus	C_{0-3}	Interrupt memory
H_5	peripheral code bus	H_2	Address code bus
Sm:	CDT digital code	S \bar{Y} J:	CRT input memory; PX: Screen
		dm:	CDT address code
		DB:	Dot label

1. Peripheral Code Bus

This bus has a total of 16 lines, i.e., DXW_8 -- DXW_{23} , this is based on the ordinary small computer and the standard word length of its terminals. For example, in this interface, CRT and CDT code lines are both 16 bits.

The peripheral code bus includes H_5 , Y_6 -- Y_9 . When the newly added peripheral equipment transmits information to the mainframe, the information is first sent to this bus and then it is sent to the code bus of the mainframe.

2. Real Time Clock Logic

In on-line operation, the real time clock is indispensable as a peripheral equipment. Our real time clock consists mainly of a frequently divider and some logic circuits that maintain blocking.

The counting pulse of the frequency divider is a field scanning pulse produced by the CRT controller. The cycle is 20 ms. After 50 frequency divisions, it produces 1 second pulses. The second pulse goes to the mainframe and requests an interrupt to establish the time unit for the whole system. The hardware retains only time units less than a minute. Time units over a minute are counted by the software and are stored in the internal memory.

3. This interface is a general purpose digital interface. It contains 16 digital code lines, 5 address code lines, 1 request line, 1 query line, and 1 clearing line. Therefore, no digital code surpasses 16 bits. All CDT devices with group codes not surpassing 5 digits (32 groups) can be connected to this interface directly or with slight modification. At present, the various types and models of telemechanic devices manufactured domestically can all be connected. Therefore, this interface has a relatively strong compatibility and adaptability.

According to our present situation, this interface has been designed to connect 16 telemechanic devices. But we thought of future development and paid full attention to the expandability of the interface so that it can conveniently be expanded in a building block style.

This interface mainly includes the queuing device, the digital code merging circuit, and the address forming circuit. They will be further explained in the following.

(1) The queuing device

The queuing device includes a channel memory corresponding to the 16 CDT units, a dot label memory, a queuing memory and a queuing logic.

The main function of the channel memory is to control the CDT device and to connect them to the computer. When it is in the "0" state, the information from the corresponding CDT, even when it is continuously sending information to the computer, cannot enter the computer.

The dot label memory is used to store transmission requests by the CDT. In the course of transmitting CDT information, the dispatching terminal receives a group of messages and after checking and finding it has no mistakes, will give the protective conditions or send out an execution allowed pulse. When it is sent to the interface it is reshaped, i.e., to form a so-called "dot label." It can be seen, the dot label is actually the label of the request message sent by the CDT to the computer and entering the computer. After reshaping, it becomes narrow, and it must be stored in the memory. Therefore, when the dot label corresponding to the kth CDT is "1" in the memory, it means that at this time, there is a group of messages from the kth CDT requesting to enter the computer. But at this time, the computer cannot immediately respond to the request by that CDT. This is because it is possible that many CDT have sent requests simultaneously. Under this situation, the computer cannot simultaneously receive the messages from that many CDTs, it can only receive the message from one CDT at a time. Therefore, after the dot label memory has stored the request label of the CDT, the request will wait for queuing.

Since the CDT data is waiting in the interface to be transferred to the computer and at the same time it also sends a label to the computer to request for processing, then how can the computer know that there is such a request and carry out corresponding processing?

The simplest way is that the computer conducts a "row call" of the possible requesting sources. This is querying their status at fixed intervals to determine whether they have any requests. If a certain CDT has a request, then when the mainframe carries out a row call, the queuing memory that responds is immediately set to "1". This indicates that that CDT has joined the queue. If only this CDT joins the queue, undoubtedly it will receive the right to be processed. If many CDTs join the queue simultaneously, then they are processed according to a preset priority order. We used the hardware queuing logic instead of software methods to realize priority ordering, therefore we simplified the software and conserved processing time.

(2) Digital Code Merging Circuit

This interface is designed according to the 16 CDTs. Each CDT allows a maximum of 16 code lines. If the 16 code lines of each CDT are all directly connected to the peripheral code bus, then the lines will be more complex, and the structure will be cluttered. The method we used is to combine all the CDT code lines into a group first before they are sent to the DWX of the peripheral code bus, forming a so-called "CDT code bus" of 16 code lines, then connecting them to the DXW.

In the actual circuit, the merging circuit consists of a series of NAND gates. They correspond and are connected to each of the CET code lines respectively. The open gate condition is the "TH" electrical potential of the station number produced by that CDT in queue. This condition is unique at any given moment. Because the queuing logic has determined that at any moment, only one CDT is in queue, therefore simultaneous occurrence does not happen. In general, this means: the data of the CDT in queue can enter the CDT code bus while the remaining data are waiting at the gate. After the computer finishes processing the request of this CDT, the electrical potential of the corresponding station

number is cleared, and thus the input gates corresponding to this CDT on the CDT code bus is closed.

(3) Address Forming Circuit

To clearly recognize at any given moment to which group of which CDT the data transferred to the computer belong, the electrical potential of the station number and the group number of the CDT must directly form an internal memory address needed by DMA (direct memory access) directly at the interface. Obviously, the basic requirement of this address forming circuit is accuracy. Before entering the interface, the station number and the group number and its content (digital codes) are consistent. After they enter the computer, they must also guarantee that the data written into a certain unit of the internal memory and the address of that unit are consistent.

As long as we carefully study the counting method of internal address and the CDT group number, it is not difficult to find out their internal consistency: They are both binary counting. Therefore, as long as the group codes of the CDTs are merged, and as long as we use the electrical potential TH of the station number as the gate opening condition, we can form a group of common CDT address buses Wdx. This interface is designed for accepting group code lines of a maximum of 5 digits per CDT unit. Therefore, the CDT group code bus formed is also 5 digits. The counting range in the decimal system is from 0 to 31.

Yet the 5-digit group codes can only form the lowest digit in the internal address. It can only differentiate the group number but it cannot differentiate the station number. For this, we still must utilize the electrical potential TH of the station number to form addresses for higher digits (the 6th to the 9th digit).

We should also point out that the internal address code of the DJS-6 computer has a total of 16 bits, and here we have only formed 9 bits, what about the high 7 digits? It is very simple. If we have determined the true address in the internal memory where the CDT data have been stored, the high 7 digits can be permanently connected by hardware. Later, if we "move" the CDT data bank, we only need to change the connections.

4. Interface of the Screen

The color CRT is a very important terminal equipment for on-line application of the computer. The dispatcher can directly view and grasp the real time operation of the power system through it. Also, it is a powerful tool in linking the dispatcher and the computer. The CRT units we added were the SDX-2 model color CRTs developed by the Nanjing Automation Institute of the Ministry of Electric Power.

The main channel linking the computer and the CRT is the CRT input and output bus. The content of the graphic memory of the CRT and the keyboard codes are all sent to the peripheral code bus DXW via the CRT input memory SrJ₀ -- SrJ₁₅, while the codes sent by the computer to the CRT all pass through the code bus DX₈ -- DX₂₃, and then they are sent to the output memory ScJ₀ -- ScJ₁₅ of the

CRT. Therefore, when designing the CRT interface, the problem is very simple. When the CRT transmits data to the mainframe, only one execution command "screen send to B" is needed and the codes in SrJ can be sent to DXW. When the mainframe sends data to the CRT, executing one "B send to screen" command will send the codes via DX to the ScJ input end of the CRT. At the same time, an ScJ receiving pulse is produced at the interface and the codes are entered into ScJ, and that receiving pulse triggers the decoding time sequence of the CRT. At this time, the CRT can work off-line.

III. Conclusion

Practice in improving this DJS-6 computer of our station has proven that the improvements are successful. The interfaces for the newly added peripheral equipment have also been reliable and stable during two years of test operation. Because we used the standard insert boards of the original DJS-6 computer in designing the interfaces (already welded parts which have also passed inspection tests), therefore we greatly reduced the amount of work and the interfaces could be used on the cards of the mainframe, thus reducing the amount of maintenance work.

The practice over the past two years has also proven that it is not only feasible to change the originally available off-line computer to an on-line operating computer, it is also very meaningful. More work can be done by spending less money. We only spent a small amount of investment to enable the computer that originally had a very low utilization rate to begin power network monitoring and control. At the same time, this also shows that the DJS-6 computer does have a very strong life force for on-line operation at the dispatching center of a power network. This is mainly because it has a relatively large internal and external memory resource, a relatively strong instruction system and interrupt system, and a very strong floating point computational function. At the same time, it also has a relatively strong real time processing ability. It can, over a fairly long time in the future, satisfy the requirements of a dispatching center that requires a good real time response and the ability to perform a large amount of complex on-line computations. In particular, the DJS-6 II model that had recently been developed successfully, has a much improved performance and price ratio and it can satisfy the requirements of mid-term plans for comprehensive automation of dispatching. Therefore, we are prepared to exert further efforts to use the present DJS-6 computer well and to continue to perfect the hardware and software, and we will especially exert efforts to do the work of developing software well so that it can make new contributions in production.

Before concluding this article, we like to take this opportunity to thank the Dispatching Center of the Guangdong Provincial Power Bureau which has helped us during the course of our work.

9296
CSO: 4013/140

END