

AD \_\_\_\_\_

GRANT NUMBER DAMD17-96-1-6124

TITLE: Characterization of Emissions from Heaters Burning Leaded Diesel Fuel in Unvented Tents

PRINCIPAL INVESTIGATOR: Yung-Sung Cheng, Ph.D.

CONTRACTING ORGANIZATION: Lovelace Biomedical and Environmental  
Research Institute, Inc.  
Albuquerque, New Mexico 87185

REPORT DATE: July 1998

TYPE OF REPORT: Annual

PREPARED FOR: Commander  
U.S. Army Medical Research and Materiel Command  
Fort Detrick, Maryland 21702-5012

DISTRIBUTION STATEMENT: Approved for public release;  
distribution unlimited

The views, opinions and/or findings contained in this report are those of the author(s) and should not be construed as an official Department of the Army position, policy or decision unless so designated by other documentation.

**DTIC QUALITY INSPECTED 1**

# REPORT DOCUMENTATION PAGE

*Form Approved*  
OMB No. 0704-0188

Public reporting burden for this collection of information is estimated to average 1 hour per response, including the time for reviewing instructions, searching existing data sources, gathering and maintaining the data needed, and completing and reviewing the collection of information. Send comments regarding this burden estimate or any other aspect of this collection of information, including suggestions for reducing this burden, to Washington Headquarters Services, Directorate for Information Operations and Reports, 1215 Jefferson Davis Highway, Suite 1204, Arlington, VA 22202-4302, and to the Office of Management and Budget, Paperwork Reduction Project (0704-0188), Washington, DC 20503.

1. AGENCY USE ONLY <i>(Leave blank)</i>	2. REPORT DATE July 1998	3. REPORT TYPE AND DATES COVERED Annual (7 Jun 97 - 6 Jun 98)	
4. TITLE AND SUBTITLE Characterization of Emissions from Heaters Burning Leaded Diesel Fuel in Unvented Tents		5. FUNDING NUMBERS DAMD17-96-1-6124	
6. AUTHOR(S) Cheng, Yung-Sung, Ph.D.			
7. PERFORMING ORGANIZATION NAME(S) AND ADDRESS(ES) Lovelace Biomedical and Environmental Research Institute, Inc. Albuquerque, New Mexico 87185		8. PERFORMING ORGANIZATION REPORT NUMBER	
9. SPONSORING / MONITORING AGENCY NAME(S) AND ADDRESS(ES) U.S. Army Medical Research and Materiel Command Fort Detrick, Maryland 21702-5012		10. SPONSORING / MONITORING AGENCY REPORT NUMBER	
11. SUPPLEMENTARY NOTES			
12a. DISTRIBUTION / AVAILABILITY STATEMENT Approved for public release; distribution unlimited		12b. DISTRIBUTION CODE	
13. ABSTRACT <i>(Maximum 200 words)</i>  Of 700,000 U.S. military personnel who served in the Persian Gulf conflict during 1990-91; some were diagnosed with a "mystery illness" or "Gulf War Syndrome." Information to study possible links between environmental exposures and the Gulf War Syndrome is limited. Oil-well fires, fumes from cook stoves, pesticides, and naturally occurring pollutants (sand, dirt, fauna) contributed to air pollution during the Gulf War conflict. This study is simulating human exposure to aerosols from unvented heaters in tents, so that the contribution of exposure to this in-tent pollutant can be estimated. Specific aims include: (1) physical and chemical characterization of aerosols from heaters used in unvented tents, and (2) estimation of exposure to particulate matter (PM) and combustion gases (CO, NO <sub>x</sub> , and SO <sub>2</sub> ). An Army tent was set up, and samplers for particles, gases, and vapors were tested. Two types of fuels were used: kerosene, JA1, and JP8, commonly used during the war. Chemical analysis of filter samples included metal and elementary carbon. PM10 and PM2.5 filter samplers were used to determine the mass concentration. A MOUDI cascade impactor was used for particle size distribution. The aerodynamic particle size distribution indicated a tri-modal size distribution from burning kerosene with the major peak between 0.1 - 1 μm. The air exchange rate, a major factor in determining the pollutant concentrations inside the tent, was determined using a SF <sub>6</sub> trace gas method. Aerosol concentration and particle size distribution were obtained by filter and impactor methods. Concentrations of NO <sub>x</sub> , CO, SO <sub>2</sub> , and HC were monitored continuously; our data indicate elevated concentrations of PM, NO, and CO. We also found that fuel type, heater, and air exchange rate are important factors in determining concentrations inside the tent. The air exchange rate (1-4/hr) was higher than within a home (0-2/hr), the tent was difficult to seal especially under windy conditions. These data will be used to calculate respiratory doses of particles and assess exposure to pollutants of the troops who served in the Gulf War.			
14. SUBJECT TERMS Gulf War Illness Inhalation, air pollution, unvented heaters, tents		15. NUMBER OF PAGES 23	16. PRICE CODE
17. SECURITY CLASSIFICATION OF REPORT Unclassified	18. SECURITY CLASSIFICATION OF THIS PAGE Unclassified	19. SECURITY CLASSIFICATION OF ABSTRACT Unclassified	20. LIMITATION OF ABSTRACT Unlimited

FOREWORD

Opinions, interpretations, conclusions and recommendations are those of the author and are not necessarily endorsed by the U.S. Army.

\_\_\_\_ Where copyrighted material is quoted, permission has been obtained to use such material.

\_\_\_\_ Where material from documents designated for limited distribution is quoted, permission has been obtained to use the material.

✓ Citations of commercial organizations and trade names in this report do not constitute an official Department of Army endorsement or approval of the products or services of these organizations.

\_\_\_\_ In conducting research using animals, the investigator(s) adhered to the "Guide for the Care and Use of Laboratory Animals," prepared by the Committee on Care and Use of Laboratory Animals of the Institute of Laboratory Resources, National Research Council (NIH Publication No. 86-23, Revised 1985).

\_\_\_\_ For the protection of human subjects, the investigator(s) adhered to policies of applicable Federal Law 45 CFR 46.

\_\_\_\_ In conducting research utilizing recombinant DNA technology, the investigator(s) adhered to current guidelines promulgated by the National Institutes of Health.

\_\_\_\_ In the conduct of research utilizing recombinant DNA, the investigator(s) adhered to the NIH Guidelines for Research Involving Recombinant DNA Molecules.

\_\_\_\_ In the conduct of research involving hazardous organisms, the investigator(s) adhered to the CDC-NIH Guide for Biosafety in Microbiological and Biomedical Laboratories.

2 J. S. Cho      6/18/98  
PI - Signature      Date

## TABLE OF CONTENTS

FRONT COVER.....	1
STANDARD FORM 298 .....	2
FOREWORD .....	3
TABLE OF CONTENTS .....	4
INTRODUCTION.....	5
BODY OF THE REPORT .....	7
ASSUMPTIONS.....	7
EXPERIMENTAL METHODS .....	7
Tent and Heaters.....	7
Sampling Instruments.....	9
Air Exchange Rate .....	9
PROCEDURES .....	10
RESULTS AND DISCUSSION .....	12
Air Exchange Rate .....	12
Temperatures and Relative Humidity .....	13
Gas Concentrations.....	13
Particle Concentration and Distribution .....	16
Chemical Elementary Analysis.....	18
Overall Results.....	18
CONCLUSIONS.....	22
REFERENCES.....	23

## INTRODUCTION

Approximately 700,000 U.S. military personnel served in the Persian Gulf conflict during 1990 and 1991. During and after the Persian Gulf War, a proportion of returned American service personnel was diagnosed as having a "mystery illness" or "Gulf War Syndrome." Manifestations of the Gulf War Syndrome have varied from person to person, but often include arthralgia, weakness, fatigue, headache, memory loss, and other mental impairments. Skin rashes and hair loss have also been mentioned.<sup>1</sup> Various causes have been suspected, including agents of chemical and biological warfare, fumes from both leaded and unleaded fuels, components of smoke from burning oil wells, illicit substitutes for alcohol, and recreational drugs.

Only limited information is available to study possible links between environmental exposures and the Gulf War Syndrome. While environmental exposures may have been important, the data needed for sound epidemiological studies are very limited. Major contributions to air pollution during the Gulf War conflict included oil-well fires in Kuwait, fumes from cook stoves and heaters, pesticides, and naturally occurring pollutants such as sand, dirt, and fauna. Most of these environmental factors have been studied and evaluated to some degree, except the exposures to pollutants produced from unvented heaters in tents. To fully characterize these exposures and the resulting potential health risk to the troops, all pathways of exposure must be evaluated.

Various types of portable space heaters have been widely used in offices and homes. Tu and Hinchliffe<sup>2</sup> studied the emissions from five portable space heaters, including three conventional electrical heaters, one quartz electrical heater, and one kerosene heater. Their results indicated that most aerosols produced were in the ultrafine particle range, and the aerosol concentration in an unvented chamber could be as high as 330  $\mu\text{g}/\text{m}^3$  from a kerosene heater used for 1 hour. Particle compositions were primarily carbon black and chromium. The gas phase was not studied. Emissions from gas-fired space heaters were reported by Traynor *et al.*<sup>3</sup> and Relwani and Moschandreas<sup>4</sup>; the primary pollutants were  $\text{CO}_2$ ,  $\text{CO}$ , and  $\text{NO}_2$  with very low mass concentrations of ultrafine particles. On the other hand, emissions from burning liquid fuels can be substantial in both gas pollutants and particles. For instance,

emissions from unvented kerosene space heaters can contribute to indoor air particulate concentrations in excess of 20  $\mu\text{g}/\text{m}^3$  over background level<sup>5</sup> and over 300  $\mu\text{g}/\text{m}^3$  in a sealed chamber<sup>2</sup>. The space heaters can also emit organic compounds such as polycyclic aromatic hydrocarbons (PAHs), in addition to  $\text{CO}_2$ , CO,  $\text{NO}_x$  and  $\text{SO}_2$ .<sup>5,6</sup> Semivolatile and particle-bound organic emissions from the kerosene heaters were found to be mutagenic.<sup>7</sup> Indoor air quality can be affected by the use of kerosene heaters; it also can be affected by human activities such as open doors and windows.<sup>8</sup>

The purpose of this study is to simulate human exposure to aerosols produced by unvented heaters in tents used in the Persian Gulf, so that the contribution of exposure to this in-tent pollutant can be estimated. The specific aims include:

1. Physical and chemical characterization of aerosols produced by heaters that burned fuels in an unvented tent.
2. Estimation of exposure to particulate matter (PM), combustion gases (such as CO,  $\text{NO}_x$ , and  $\text{SO}_2$ ), and other compounds (such lead, PAHs etc.).

During the first year of the project, we had extensive discussions with several Army laboratories on tents, tent heaters (US Army, Natick Research Development and Evaluation Center), and fuels (Fuels & Lubricants Technology Team, Mobility Technology Center - Fort Belvoir). Based on these discussions, it was determined that the unvented heaters most likely used in the Gulf War were commercial units that burned kerosene and aviation fuels, primarily JA1 and JP8 fuels which are kerosene-based and have similar compositions. The standard Army heater is vented outside of the tent and is much less a concern for inhalation health effects. After we gathered this information, we then purchased a used Army tent, an Army tent heater, and two kinds of kerosene heaters. The tent was set up, and various pieces of instrumentation including samplers for particles, gases, and vapors were tested. Data from one kerosene heater using kerosene fuel were reported in the 1997 annual report.

Based on results of the initial experiments, we added several instruments to measure both particle and gas concentrations during the second year of the project. From these instruments, we can estimate the exposure to particles less than 10  $\mu\text{m}$  and 2.5  $\mu\text{m}$  (PM-10 and PM-2.5) and the distribution of ultrafine particles. We can also monitor the real-time particle and gas concentration. The experiments were run under various conditions during this second year. We added another kerosene heater for a total of three types of heater in the experiments.

Two more fuels, JA1 and JP8, were added, as well as three different air exchange rates, when the tent-doors were open, closed, and half-opened. Preliminary data for these experiments are reported here.

## **BODY OF THE REPORT**

### **ASSUMPTIONS**

The primary purpose of this study is to characterize, physically and chemically, the aerosols produced from unvented heaters. Aerosols produced from the burning fuels are generally formed from vapor condensation of burning fuel and from residuals of incomplete combustion. We assumed that soldiers were primarily exposed to emissions from unvented heaters in tents. We also assumed that the types of fuel, heaters, and the air exchange rate were the major factors influencing the emission characteristics and, therefore, the exposure.

### **EXPERIMENTAL METHODS**

#### **Tent and Heaters**

A used vinyl-backed canvass Army tent (GP medium, 16 ft x 32 ft) was purchased following discussions with Army personnel at the Natick Research Development and Evaluation Center. Six unvented heaters were also purchased: two each of the convection-type heaters (RMC-95, RMC International, Denver, CO, rated at 22,300 Btu per hr, and Omni-105, Toyotomi U.S.A., Inc. rated at 23,000 Btu per hr) and two radiant heaters (Model AWHR-1101, Cans Unlimited, Inc., Greer, SC, rated at 10,000 Btu per hr). In addition, a standard Army tent heater (Model H-45, Type II) was purchased. 1-K kerosene (Parks Co., Fall River, MA), JA-1 jet fuel, and JP-8 jet fuel were used.

The heaters were placed inside the tent to mimic their use in the Persian Gulf. The tent was set up inside a clamshell structure to better control the environment (Figures 1 and 2). The volumes of the tent and clamshell structure were estimated, based on their geometry, to be 100 and 5000 m<sup>3</sup>, respectively.

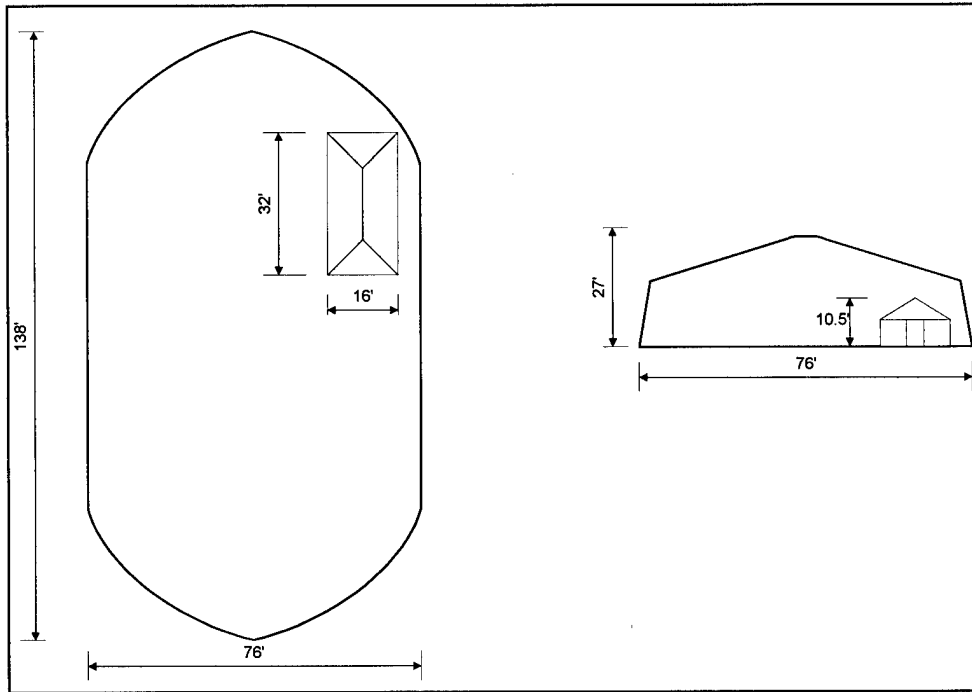

Figure 1. Schematic of the Army tent inside the clamshell.

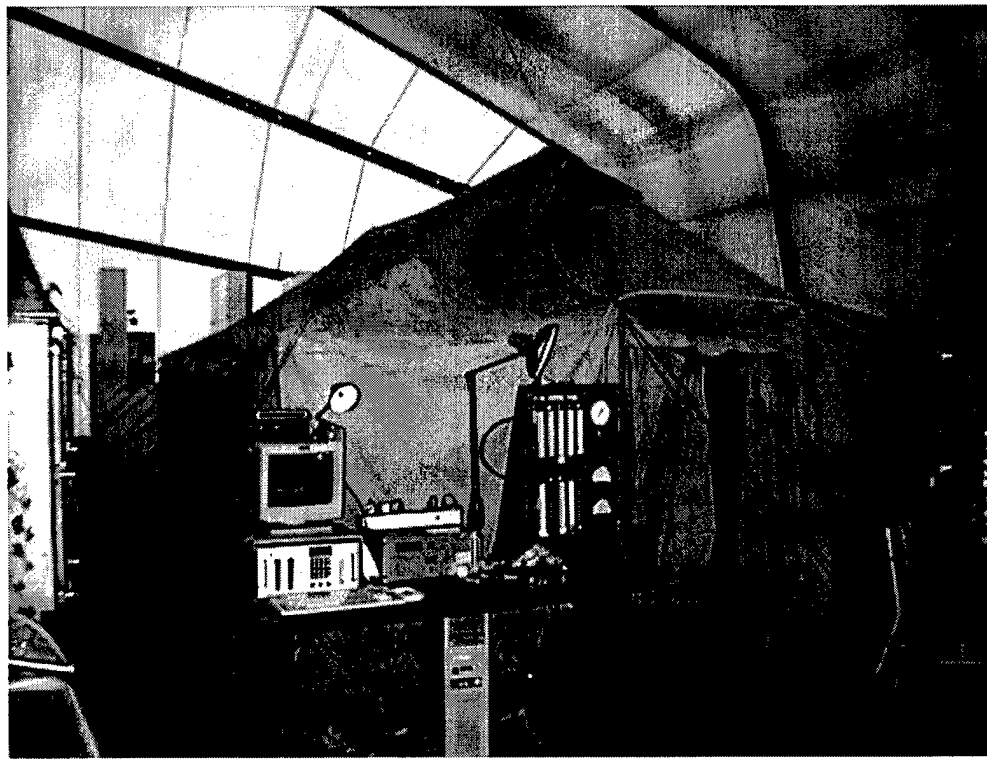

Figure 2. The Army tent and the instrument control panel.

### Sampling Instruments

Assuming that the aerosols produced by the heaters were mostly in the fine and ultrafine particle size range, and the vapor-phase emission contained PAHs and lead, the following aerosol sampling instruments were selected for this study:

1. Six PEMs (Personal Environmental Monitor, Model 200, MSP Corporation, Minneapolis, MN) were used to determine the particulate matter, three for PM-10 and three for PM-2.5
2. A 10-stage MOUDI (Micro-Orifice Uniform Deposit Impactor, Model 110, MSP Corporation, Minneapolis, MN) was used for aerosol size distributions between 0.056 - 18  $\mu\text{m}$ .<sup>9</sup>
3. A DataRAM real-time aerosol monitor (Monitoring Instruments for the Environment, Inc., Bedford, MA) was used to measure the particle concentration in real time. The particle size range of maximum response is from 0.1  $\mu\text{m}$  to 10  $\mu\text{m}$ . The concentration measurement range of the DataRAM is from 0.1  $\mu\text{g}/\text{m}^3$  to 399.99  $\text{mg}/\text{m}^3$ .

Two kinds of filters, Teflon and quartz, were used in the PEM samplers. After being weighed for PM-10 and PM-2.5, they were used for elementary chemical analysis, which was done at the Desert Research Institute in Reno, NV. Gaseous emissions were also monitored using the following instruments:

1. CO infrared analyzer (Model 865 Beckman Instruments, Fullerton, CA)
2.  $\text{NO}_x$  chemilumination analyzer (Model 8440, Monitor Labs, San Diego, CA)
3. Multi-Gas Monitor (Multiwarn II, Draeger Safety, Inc., Pittsburgh, PA) which measures multiple gases, such as CO,  $\text{SO}_2$ ,  $\text{NO}_2$ , and hydrocarbons.

### Air Exchange Rate

The air exchange rate in the tent is a major factor in determining the pollutant concentrations inside the tent. The exchange rate was determined using a trace gas method.<sup>9</sup> A predetermined amount of  $\text{SF}_6$  was released into the tent, and the  $\text{SF}_6$  concentration was monitored using an Autotrac monitor (Model 101, Lagus Applied Technology, San Diego, CA). The  $\text{SF}_6$  concentration can be fitted into the following equation:<sup>9</sup>

$$C = C_0 e^{-\lambda t} \quad (1)$$

where C and  $C_0$  are  $\text{SF}_6$  concentrations in time t and 0, and  $\lambda$  is the air exchange rate ( $\text{hr}^{-1}$ ).

This equation can also be used to estimate the volume of SF<sub>6</sub> in the tent. By injecting a known volume of SF<sub>6</sub> and from the fitted value of C<sub>o</sub>, one can determine the tent volume:

$$V_{tent} = \frac{C_o}{V_{SF6}} \quad (2)$$

## PROCEDURES

Figure 3 shows the schematic of sampling instruments used in the tent. Gas analyzers were calibrated and the filter and impactor substrates weighed. The ventilation rate within the tent was measured using the trace gas method as just described. A trace amount of SF<sub>6</sub> in the compressed gas cylinder was released to give an initial concentration between 10-100 ppb in the tent. Changes in the ventilation rate were investigated under various conditions when the tent-doors were opened, closed, or half-opened.

The gas and aerosol monitors were turned on, then the heaters were ignited (usually two identical heaters were used in the test). The heaters were well maintained. Aerosol samples were taken by using the filters in PEMs and the MOUDI. Real-time aerosol concentration and size distribution were measured by using DataRAM. CO, NO, SO<sub>2</sub>, total hydrocarbons, and SO<sub>2</sub> concentrations were monitored continuously. The heaters were turned off after 4 hours, and the monitoring continued for another hour.

The aerosol mass collected on the filters and the substrates was determined by weighing them before and after each run, using a Cahn-31 electrobalance (Cahn Instruments Inc., Cerritos, CA). The filter samples were analyzed for chemical elements at the Desert Research Institute. The time-averaged aerosol size distributions were calculated from the weighing data of the MOUDI and the stage effective cut-off diameters.

All sampling probes were positioned between 19-24 inches off the ground (see Figure 3) in order to simulate inhalation while sleeping. Temperatures were measured at four points in the tent: at center of the tent, at the heights of 24, 60, and 72 inches, and in the corner at the height of 24 inches.

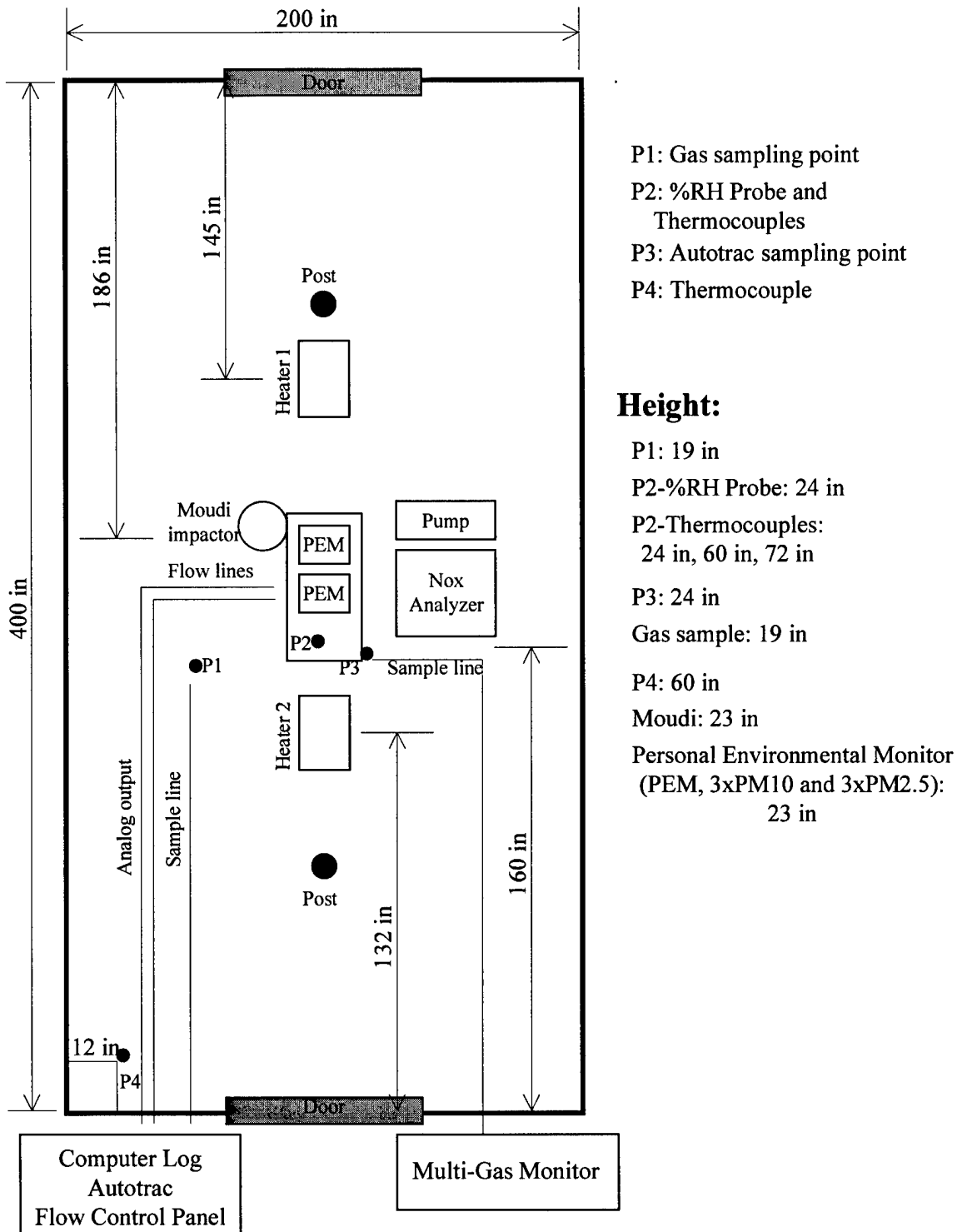

Figure 3. Schematic drawing of the sampling instruments in the tent.

## RESULTS AND DISCUSSION

Twenty-seven test runs were made under the various conditions. In the following discussion and figures (Figures 4-13), the data shown are from one test using the JA-1 fuel and the AWHR-1101 heater. The overall results for these 27 runs will be shown later in Table 1.

### Air Exchange Rate

The air exchange rate in the tent was adjusted by closing and opening the door. Figure 4 shows the  $SF_6$  concentration profile from an experiment. The curve of  $C = 30.9 e^{-1.36t}$  was the fitted curve. The intercept of  $C_0 = 30.9$  ppb was the initial concentration, and the air exchange rate,  $\lambda$  was  $1.36 \text{ hr}^{-1}$ .

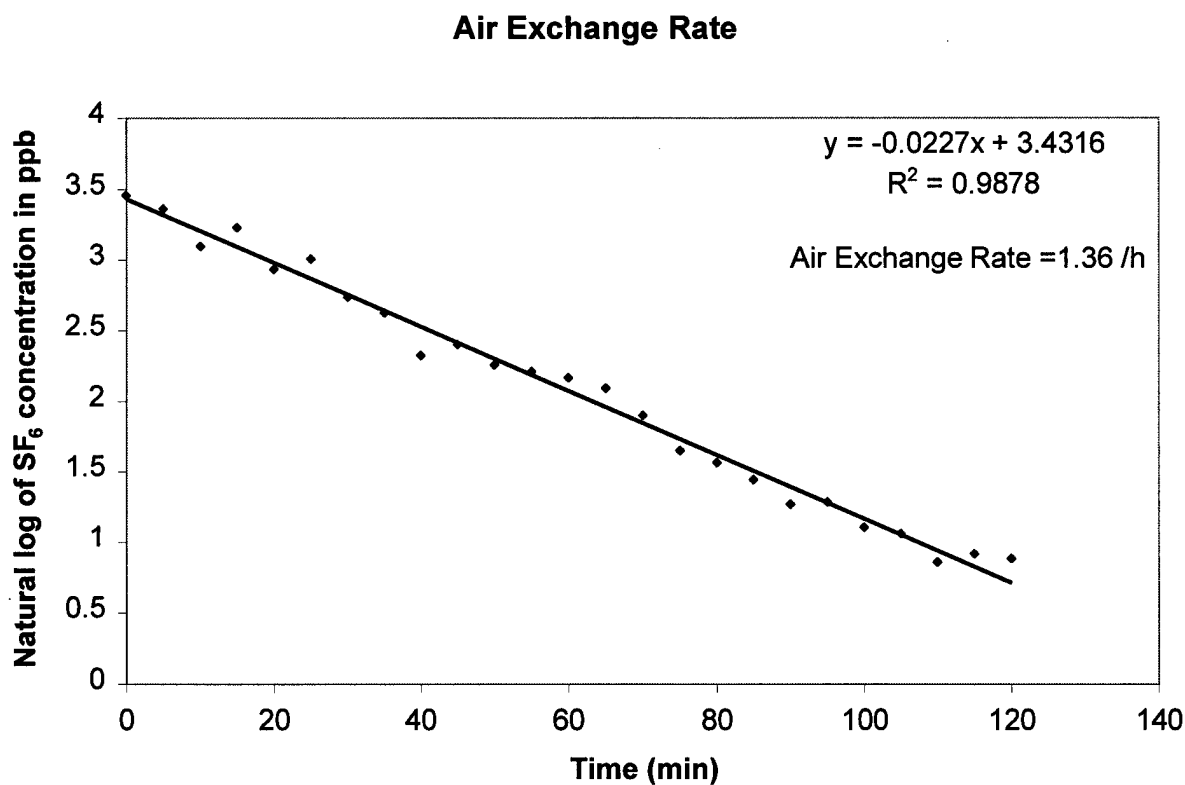

Figure 4.  $SF_4$  concentration decay as a function of time.

### Temperatures and Relative Humidity

Figures 5 and 6 show the rise in temperature and relative humidity (RH) as a function of time, suggesting a rapid rise after the heaters were ignited and a rapid decline after the heaters were turned off.

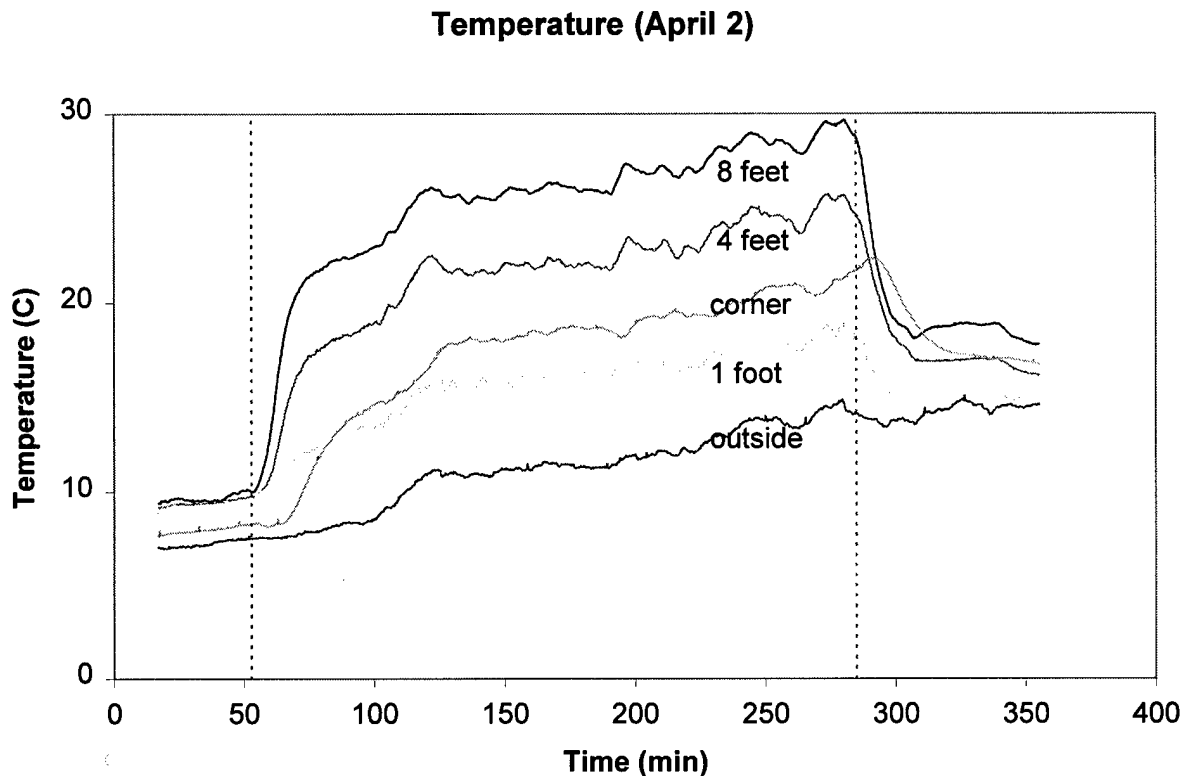

Figure 5. Temperature profile inside and outside the tent during a test run with two AWHR-1101 heaters.

### Gas Concentrations

Figures 7 - 10 show concentration profiles of NO, CO, and SO<sub>2</sub>. The profiles indicate the increases and decreases of gases generated from the combustion process. It appears that the NO concentration reached a plateau after the continuous operation of the heater, whereas the CO concentration peaked at about 20 min after the heaters were turned on, then the concentration decreased. The SO<sub>2</sub> concentration reached the peak at about 3 hours after the heaters were turned on and decreased very quickly after the heaters were turned off.

### Relative Humidity (April 2)

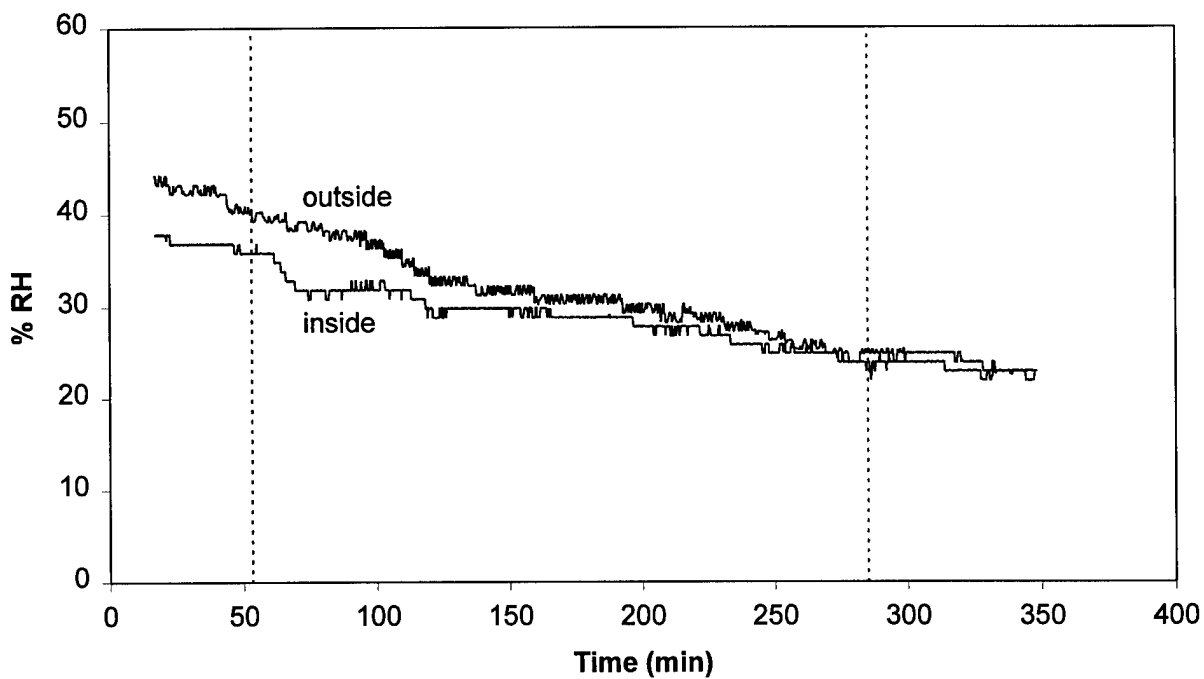

Figure 6. Relative humidity profile inside and outside the tent.

### NO Analyzer (April 2)

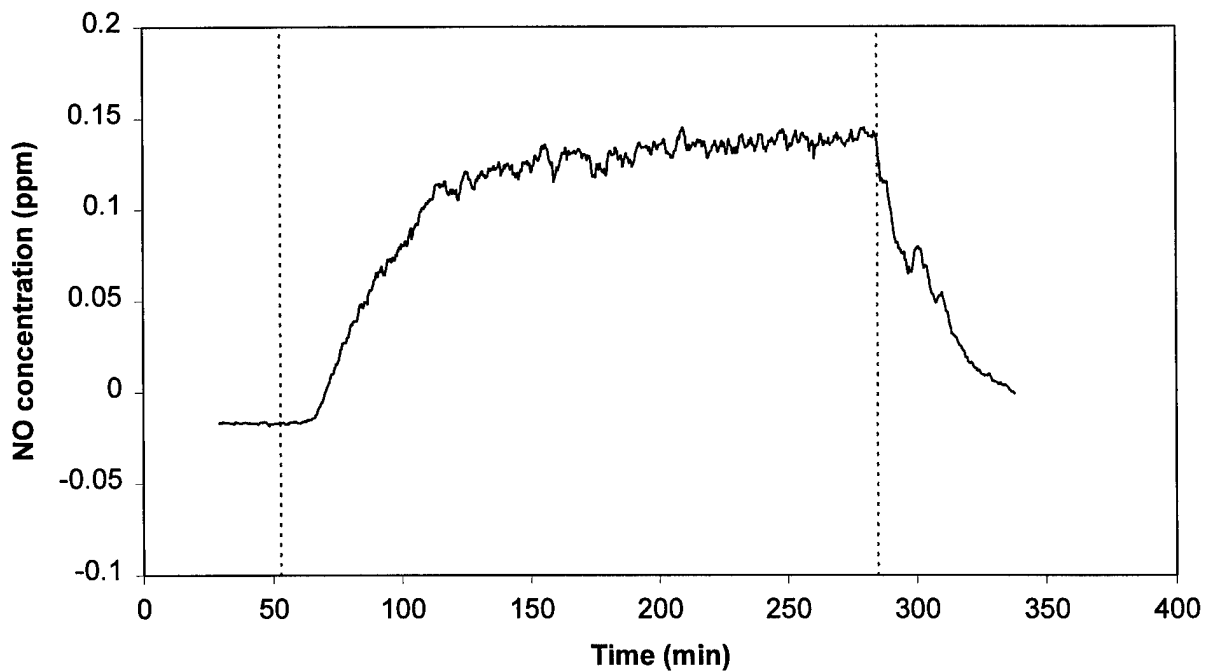

Figure 7. NO concentration profile.

### CO Analyzer (April 2)

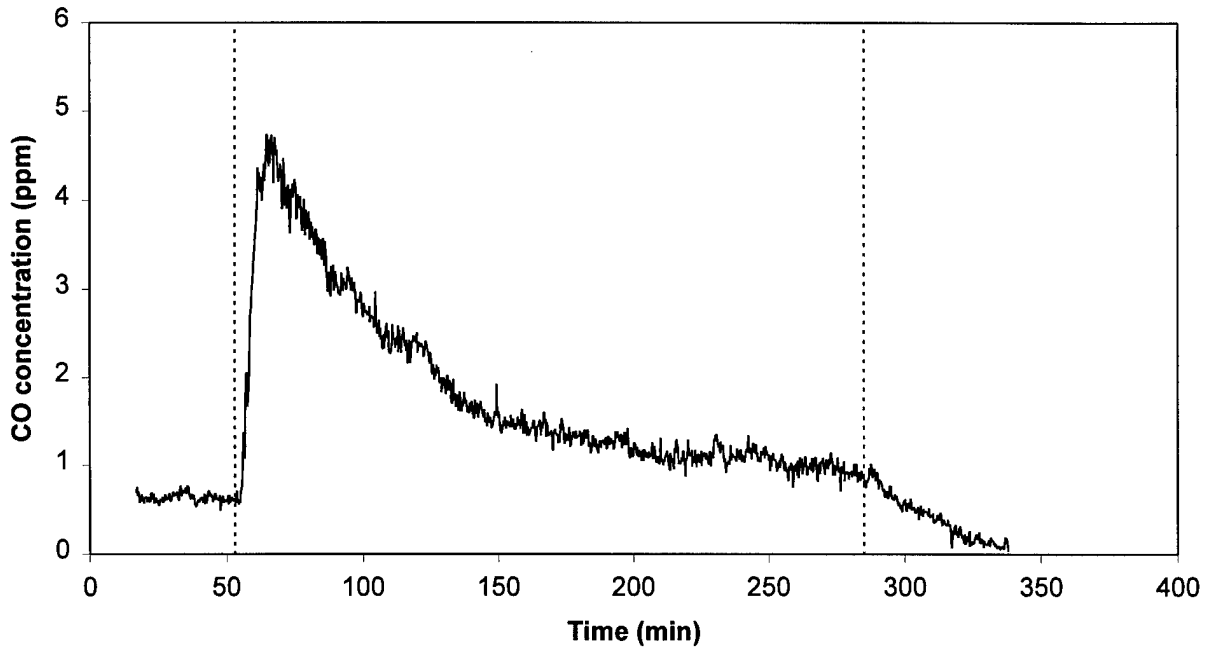

Figure 8. CO concentration profile measured by the CO analyzer.

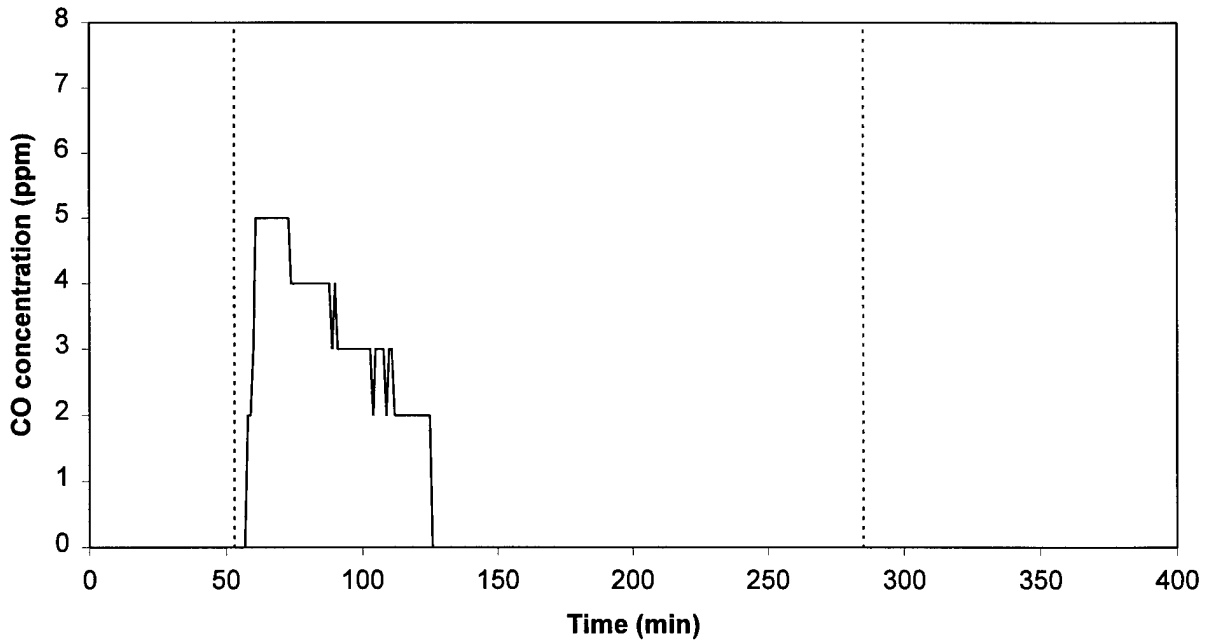

Figure 9. CO concentration profile measured by the Multi-Gas Monitor.

### SO<sub>2</sub> (April 2)

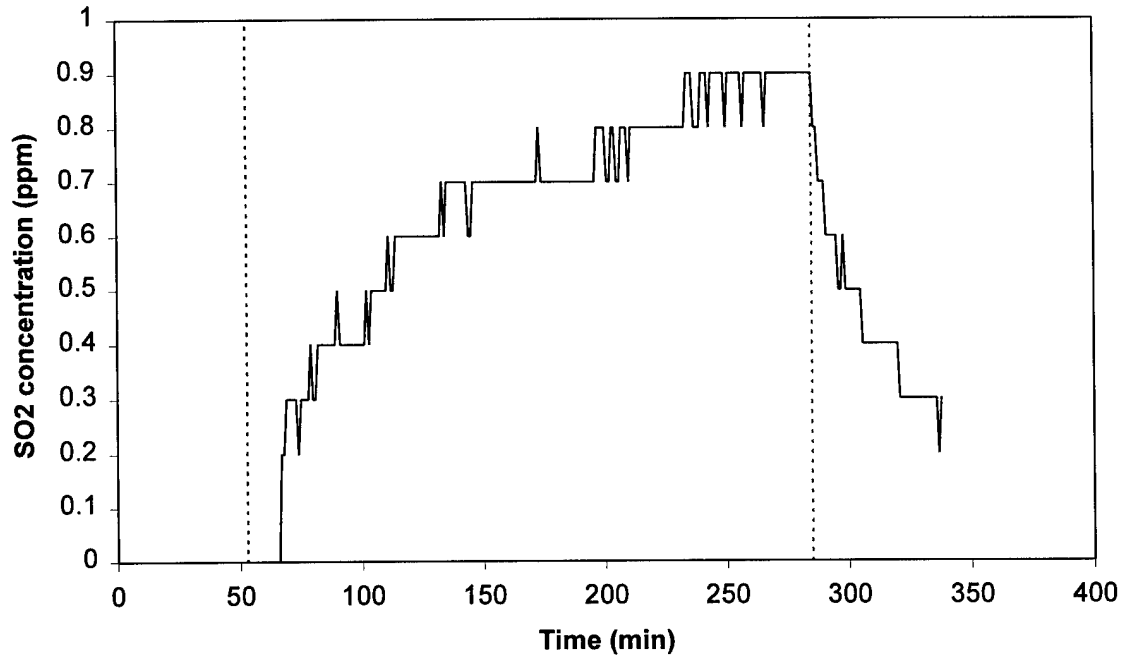

Figure 10. SO<sub>2</sub> concentration profile measured by the Multi-Gas Monitor.

#### Particle Concentration and Distribution

Figure 11 shows the particle mass concentration as a function of time, which suggests peak concentrations after the heaters were turned on and off. Figure 12 shows the particle size distribution measured by the MOUDI cascade impactor. A peak was found at around 0.2 or 0.3  $\mu\text{m}$ , which means that most particles from the heaters were ultrafine. Bimodal distributions with another mode at around 10  $\mu\text{m}$  were also found in some runs when the air exchange rate was high. The large particle indicates the environmental effect.

### Real-time particle concentration

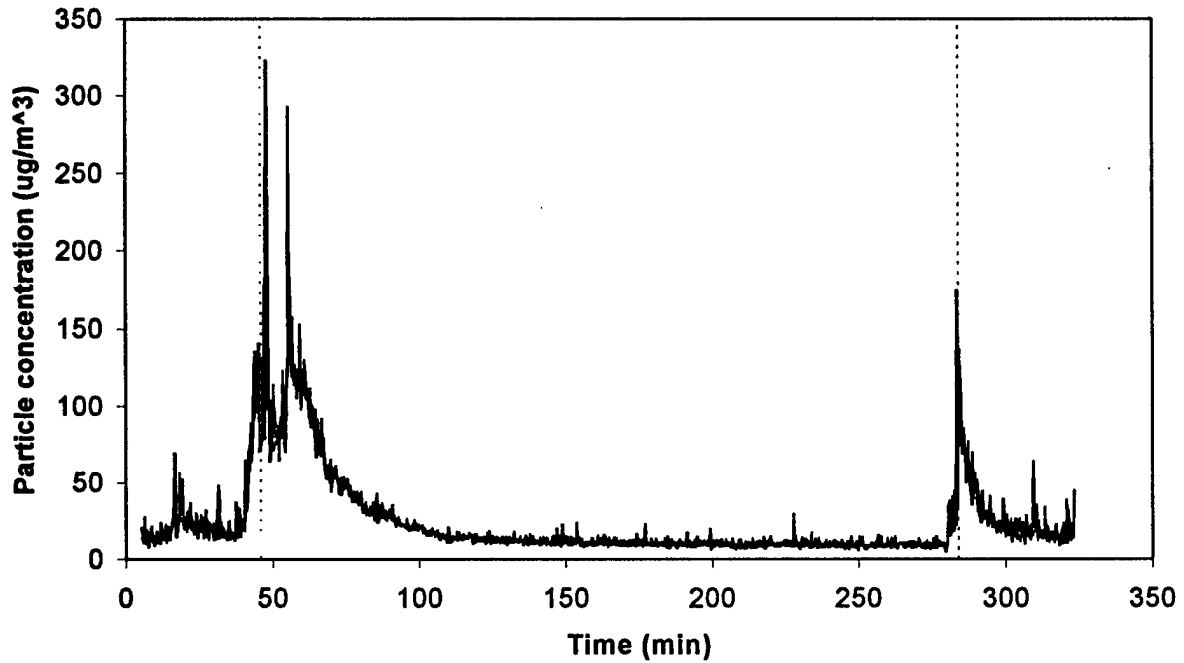

Figure 11. Particle mass concentration profile.

### Size Distribution

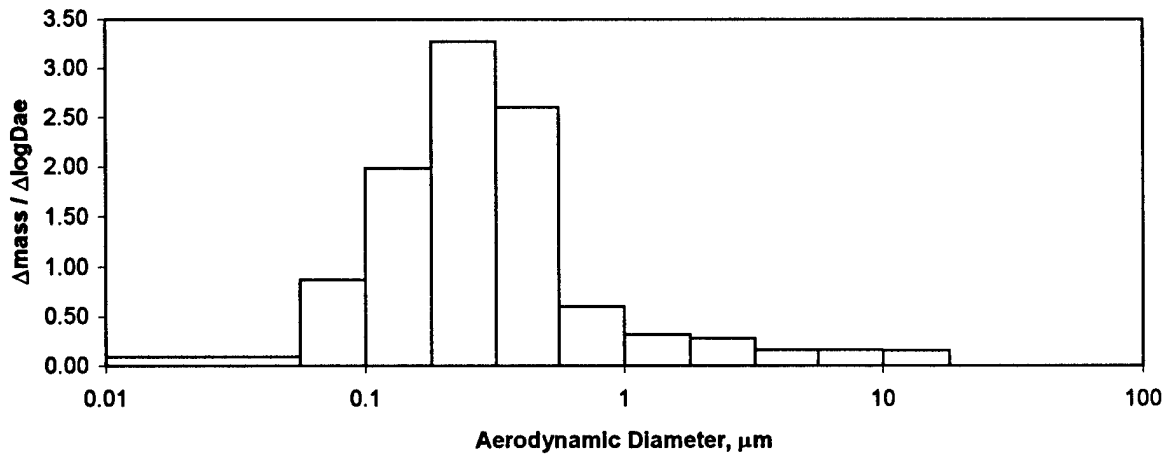

Figure 12. Particle size distribution from the MOUDI impactor.

Chemical Elementary Analysis

Figure 13 shows the results of the elementary chemical analysis and the significantly high concentration of sulfur. These results also agree with the gas analysis shown in Figure 10.

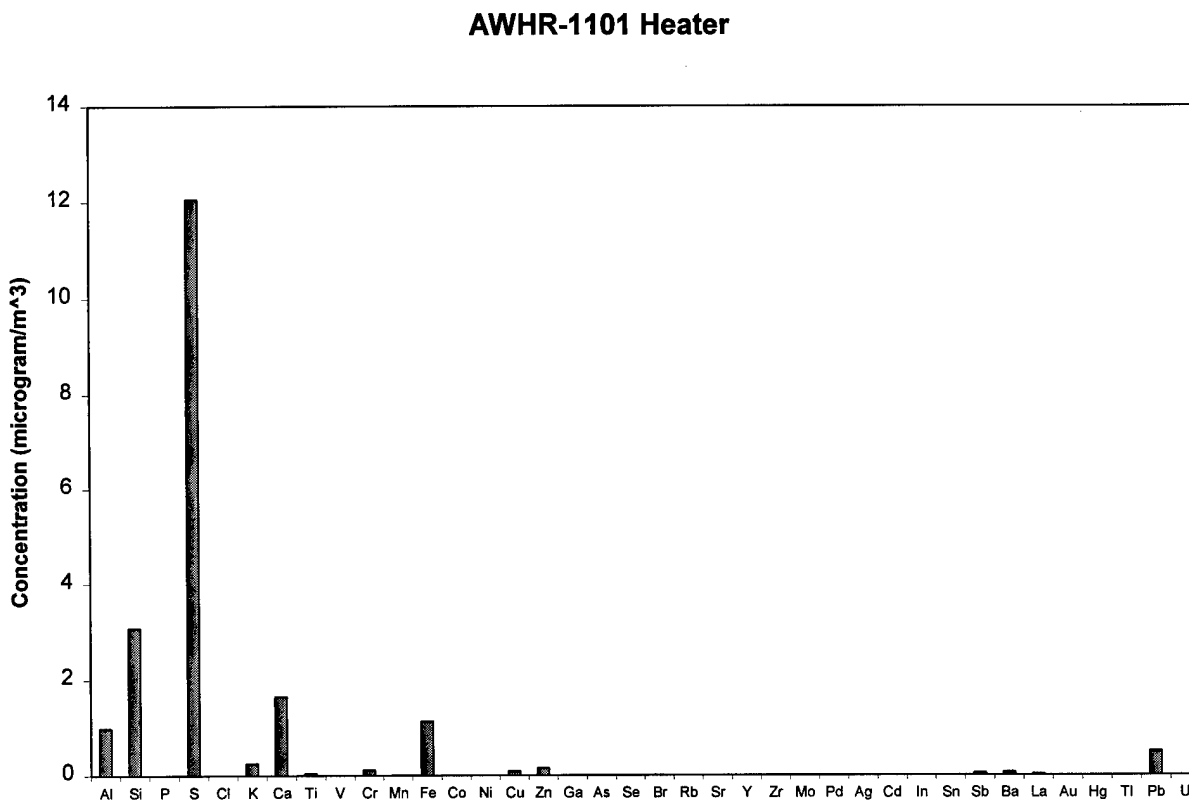

Figure 13. Elementary chemical analysis.

Overall Results

Table 1 summarizes particulate and gaseous concentrations for all 27 tests. These tests were done at an air exchange rate of between 1.0 and 3.58. The mean particulate and gaseous concentrations were calculated while the heaters were on. The concentrations decreased with the increasing air exchange rate, indicating the effects due to air exchange.

Table 1. Summary of Emission Data

Heater	AWHR	RMC	Omni	AWHR	RMC	Omni	AWHR	RMC	Omni
Fuel	1-K	1-K	1-K	1-K	1-K	1-K	1-K	1-K	1-K
Air exchange rate (/h)	1.00	1.08	1.22	1.92	2.13	1.84	3.30	3.08	3.22
Temperature, 8 ft (°C)	38.30	N/A	45.70	26.40	43.40	42.80	28.80	38.00	39.40
Temperature, 4 ft (°C)	34.10	N/A	35.10	21.00	28.20	29.40	23.10	21.40	27.30
Temperature, 1 ft (°C)	26.20	16.50	25.50	14.20	18.10	20.20	15.20	12.80	19.10
Temp. corner 4 ft (°C)	30.00	N/A	32.30	18.80	31.60	32.70	21.80	29.20	29.20
Temperature, out (°C)	25.70	6.80	22.20	11.90	17.40	19.80	14.10	14.10	16.60
RH, inside (%)	20.00	50.50	31.90	20.30	18.00	17.90	25.00	19.70	22.00
RH, outside (%)	17.90	62.20	32.00	22.50	20.60	21.70	28.10	22.2	27.10
NO mean (ppm)	0.130	1.170	1.250	0.129	0.375	0.457	0.125	0.087	0.304
NO peak (ppm)	0.210	1.560	1.650	0.320	0.622	0.738	0.346	0.258	0.430
CO mean (ppm)	1.140	1.210	1.770	N/A	N/A	N/A	N/A	N/A	N/A
CO peak (ppm)	9.420	1.870	2.730	N/A	N/A	N/A	N/A	N/A	N/A
CO mean, Multi (ppm)	1.350	0.000	1.710	0.560	0.000	0.000	0.910	0.000	0.620
CO peak, Multi (ppm)	16.000	0.000	5.000	17.000	0.000	0.000	16.00	0.000	7.000
SO <sub>2</sub> mean, Multi (ppm)	0.190	0.000	1.420	0.001	0.000	0.240	0.007	0.000	0.060
SO <sub>2</sub> peak, Multi (ppm)	0.500	0.000	1.800	0.200	0.000	0.700	0.300	0.000	0.500
NO <sub>2</sub> mean, Multi (ppm)	0.000	0.200	0.000	0.000	0.000	0.000	0.000	0.000	0.000
NO <sub>2</sub> peak, Multi (ppm)	0.000	0.300	0.000	0.000	0.000	0.000	0.000	0.000	0.000
CH <sub>4</sub> mean, Multi (ppm)	0.000	0.000	0.000	0.000	0.000	0.000	0.000	0.000	0.000
CH <sub>4</sub> peak, Multi (ppm)	0.000	0.000	0.000	0.000	0.000	0.000	0.000	0.000	0.000
PM-10 (mg/m <sup>3</sup> )	0.854	0.327	0.639	0.046	0.029	0.061	0.043	0.026	0.035
PM-2.5 (mg/m <sup>3</sup> )	0.678	0.317	0.477	0.040	0.027	0.059	0.034	0.017	0.032

Table 1 (continued). Summary of Emission Data

Heater	AWHR	RMC	Omni	AWHR	RMC	Omni	AWHR	RMC	Omni
Fuel	JA-1	JA-1	JA-1	JA-1	JA-1	JA-1	JA-1	JA-1	JA-1
Air exchange rate (/h)	1.36	1.13	1.31	2.41	2.24	2.28	3.20	3.44	3.59
Temperature, 8 ft (°C)	25.30	36.40	45.30	41.10	39.30	37.40	31.50	40.60	47.10
Temperature, 4 ft (°C)	21.40	27.10	35.80	36.60	28.10	26.90	27.20	26.80	34.30
Temperature, 1 ft (°C)	15.60	18.40	24.60	27.20	17.40	18.10	18.70	17.80	26.10
Temp. corner 4 ft (°C)	17.20	25.40	33.20	32.40	27.10	27.60	23.00	33.80	39.10
Temperature, out (°C)	11.20	14.10	21.40	27.90	15.30	15.10	17.90	17.40	25.10
RH, inside (%)	28.90	30.70	22.40	8.20	23.20	19.20	23.90	17.70	11.00
RH, outside (%)	31.60	33.20	23.00	9.30	31.20	30.60	31.40	24.10	13.70
NO mean (ppm)	0.105	1.612	1.642	0.050	0.769	0.498	0.000	0.065	0.034
NO peak (ppm)	0.145	2.220	2.016	0.084	1.431	0.670	0.078	0.302	0.127
CO mean (ppm)	1.810	0.473	0.000	0.780	0.454	0.078	0.011	0.266	0.000
CO peak (ppm)	4.735	1.234	1.207	6.744	1.489	0.849	1.558	1.612	0.720
CO mean, Multi (ppm)	0.980	0.050	2.140	0.167	0.000	0.000	0.000	0.000	0.000
CO peak, Multi (ppm)	5.000	3.000	6.000	6.000	0.000	0.000	0.000	0.000	0.000
SO <sub>2</sub> mean, Multi (ppm)	0.640	0.000	1.500	0.062	0.440	0.000	0.000	0.000	0.005
SO <sub>2</sub> peak, Multi (ppm)	0.900	0.000	2.500	0.300	0.900	0.000	0.000	0.000	0.200
NO <sub>2</sub> mean, Multi (ppm)	0.000	0.004	0.000	0.000	0.000	0.000	0.000	0.000	0.000
NO <sub>2</sub> peak, Multi (ppm)	0.000	0.300	0.000	0.000	0.000	0.000	0.000	0.000	0.000
CH <sub>4</sub> mean, Multi (ppm)	0.000	0.000	0.000	0.000	0.000	0.000	0.000	0.000	0.000
CH <sub>4</sub> peak, Multi (ppm)	0.000	0.000	0.000	0.000	0.000	0.000	0.000	0.000	0.000
PM-10 (mg/m <sup>3</sup> )	0.375	0.116	0.493	0.049	0.111	0.029	0.034	0.022	0.029
PM-2.5 (mg/m <sup>3</sup> )	0.344	0.072	0.378	0.033	0.107	0.017	0.027	0.016	0.018

Table 1 (concluded). Summary of Emission Data

Heater	AWHR	RMC	Omni	AWHR	RMC	Omni	AWHR	RMC	Omni
Fuel	JP-8	JP-8	JP-8	JP-8	JP-8	JP-8	JP-8	JP-8	JP-8
Air exchange rate (/h)	1.19	1.43	1.37	2.12	2.29	2.04	3.31	3.55	3.52
Temperature, 8 ft (°C)	35.10	39.20	43.50	39.20	39.10	38.70	34.90	48.70	45.90
Temperature, 4 ft (°C)	30.50	28.20	33.70	34.40	27.00	26.80	30.40	34.80	33.30
Temperature, 1 ft (°C)	22.90	19.10	23.20	26.20	16.30	17.10	21.30	26.00	23.70
Temp. corner 4 ft (°C)	25.90	26.40	32.00	30.30	27.90	28.00	27.60	40.20	38.10
Temperature, out (°C)	19.30	12.10	18.80	23.90	12.00	12.90	22.70	25.40	24.30
RH, inside (%)	20.00	23.80	13.60	16.40	20.50	20.00	18.30	12.10	14.70
RH, outside (%)	23.70	32.80	16.20	22.60	31.50	32.80	23.90	16.50	20.50
NO mean (ppm)	0.120	1.437	1.508	0.012	0.603	0.426	0.000	0.035	0.037
NO peak (ppm)	0.172	1.835	1.942	0.052	0.904	0.866	0.000	0.170	0.143
CO mean (ppm)	1.125	1.590	0.532	0.813	0.276	0.520	0.510	0.747	0.354
CO peak (ppm)	3.942	7.569	1.099	6.540	0.701	2.238	3.579	1.286	1.135
CO mean, Multi (ppm)	0.450	0.586	0.017	0.311	0.000	0.000	0.085	0.000	0.000
CO peak, Multi (ppm)	8.000	4.000	2.000	7.000	0.000	0.000	8.000	0.000	0.000
SO <sub>2</sub> mean, Multi (ppm)	0.140	0.000	0.105	0.009	0.000	0.000	0.000	0.002	0.010
SO <sub>2</sub> peak, Multi (ppm)	0.400	0.000	0.300	0.200	0.000	0.000	0.000	0.200	0.200
NO <sub>2</sub> mean, Multi (ppm)	0.000	0.050	0.000	0.000	0.000	0.000	0.000	0.000	0.000
NO <sub>2</sub> peak, Multi (ppm)	0.000	0.300	0.000	0.000	0.000	0.000	0.000	0.000	0.000
CH <sub>4</sub> mean, Multi (ppm)	0.000	0.000	0.000	0.000	0.000	0.000	0.000	0.000	0.000
CH <sub>4</sub> peak, Multi (ppm)	0.000	0.000	0.000	0.000	0.000	0.000	0.000	0.000	0.000
PM-10 (mg/m <sup>3</sup> )	0.109	0.083	0.096	0.052	0.076	0.057	0.044	0.033	0.041
PM-2.5 (mg/m <sup>3</sup> )	0.105	0.061	0.062	0.039	0.063	0.038	0.036	0.030	0.037

## CONCLUSIONS

In the second year of this project, we conducted all of the experiments with three different heaters and three different fuels. The tent was set up in the clamshell so the air exchange rate could be controlled more easily. Our experimental data indicate high concentrations of PM, NO<sub>x</sub>, CO, and SO<sub>2</sub> inside the tent, particularly when the tent doors were closed. From the experimental data, we see that the AWHR-1101 heater produced more emissions for both the particle and gas concentrations than the other two kinds of heaters, even though it is less powerful (10,000 Btu/h) than the others (22,000 Btu/h). The 1-K kerosene showed the highest particle and gas concentrations among the three kinds of fuels, whereas the JP-8 showed the lowest. Lastly, the particle and gas concentrations decreased with the increasing air exchange rate.

Only one set of data from the elementary chemical study is available now. Other data for the elementary analysis are still being analyzed.

The tent was also set up outside the clamshell to simulate the actual conditions during the Persian Gulf War. Experiments have been done, and analysis is underway. All of these data will then be applied in calculating the respiratory doses of particles to assess the exposure of the troops to pollutants.

## REFERENCES

1. Institute of Medicine (IOM) Report Health Consequences of Service During the Persian Gulf War: Initial Findings and Recommendations for Immediate Action. National Academy Press, Washington, DC, 1995
2. Tu KW, Hinchliffe LE: A study of particulate emissions from portable space heaters. *Am Ind Hyg Assoc J* 1983; 44: 857-862
3. Traynor GW, Girman JR, Apte MG, Dillworth JF: Indoor air pollution due to emissions from unvented gas-fired space heaters. *JAPCA* 1985; 35: 231-237
4. Relwani SM, Moschandreas DJ: Effects of operational factors on pollutant emission rates from residential gas appliances. *JAPCA* 1986; 36: 1233-1237
5. Leaderer BP, Boone PM: Total particle, sulfate, and acidic aerosol emissions from kerosene space heaters. *Environ Sci Technol* 1990; 24: 908-912
6. Traynor GW, Apte MG, Sokol HA, Chuang JC, Tucker WG, Mumford JL: Selected organic pollutant emissions from unvented kerosene space heaters. *Environ Sci Technol* 1990; 24: 1265-1270
7. Mumford JL, Lewtas J, Williams K, Tucker WG, Traynor GW: Mutagenicity of organic emissions from unvented kerosene heaters in a chamber study. *J Toxicol Environ Health* 1992; 36: 151-159
8. Setiani O: Indoor air quality and ventilation strategies in the use of combustion space heating appliances in housing. *Hiroshima J Med Sci* 1994; 43: 163-167
9. Cheng YS, Bechtold WE, Yu CC, Hung IF: Incense smoke: Characterization and dynamics in indoor environments. *Aerosol Sci Technol* 1995; 23: 271-281