



**US Army Corps  
of Engineers**

Waterways Experiment  
Station

Final Report  
CPAR-SL-98-1  
September 1998

---

## **CONSTRUCTION PRODUCTIVITY ADVANCEMENT RESEARCH (CPAR) PROGRAM**

Technologies for Improving the Evaluation and  
Repair of Concrete Bridge Decks: Ultrasonic  
Pulse Echo and Polymer Injection

by

A. Michel Alexander, Richard W. Haskins, Robert Cook,  
Mantu Baishya, Michael Kelly

19981005 162

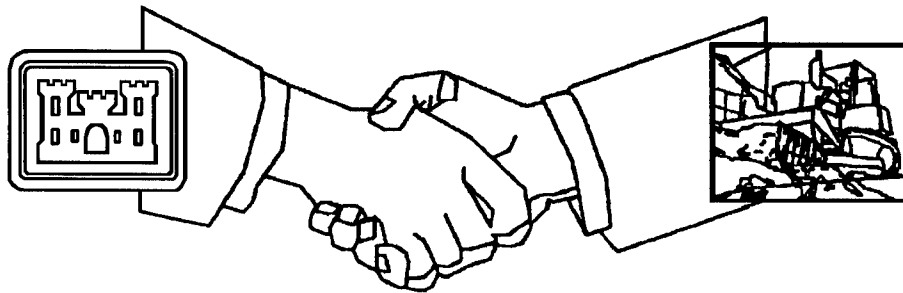

**A Corps/Industry Partnership to Advance  
Construction Productivity and Reduce Costs**

The contents of this report are not to be used for advertising, publication, or promotional purposes. Citation of trade names does not constitute an official endorsement or approval of the use of such commercial products.

The findings of this report are not to be construed as an official Department of the Army position, unless so designated by other authorized documents.



**PRINTED ON RECYCLED PAPER**

**Construction Productivity Advancement  
Research (CPAR) Program**

Final Report  
CPAR-SL-98-1  
September 1998

# **Technologies for Improving the Evaluation and Repair of Concrete Bridge Decks: Ultrasonic Pulse Echo and Polymer Injection**

by A. Michel Alexander, Richard W. Haskins

U.S. Army Corps of Engineers  
Waterways Experiment Station  
3909 Halls Ferry Road  
Vicksburg, MS 39180-6199

Robert Cook, Mantu Baishya, Michael Kelly  
University of Nebraska Center for Infrastructure Research  
60th and Dodge Street  
Omaha, NE 68182-0461

Final report

Approved for public release; distribution is unlimited

Prepared for U.S. Army Corps of Engineers  
Washington, DC 20314-1000



**US Army Corps  
of Engineers**  
Waterways Experiment  
Station

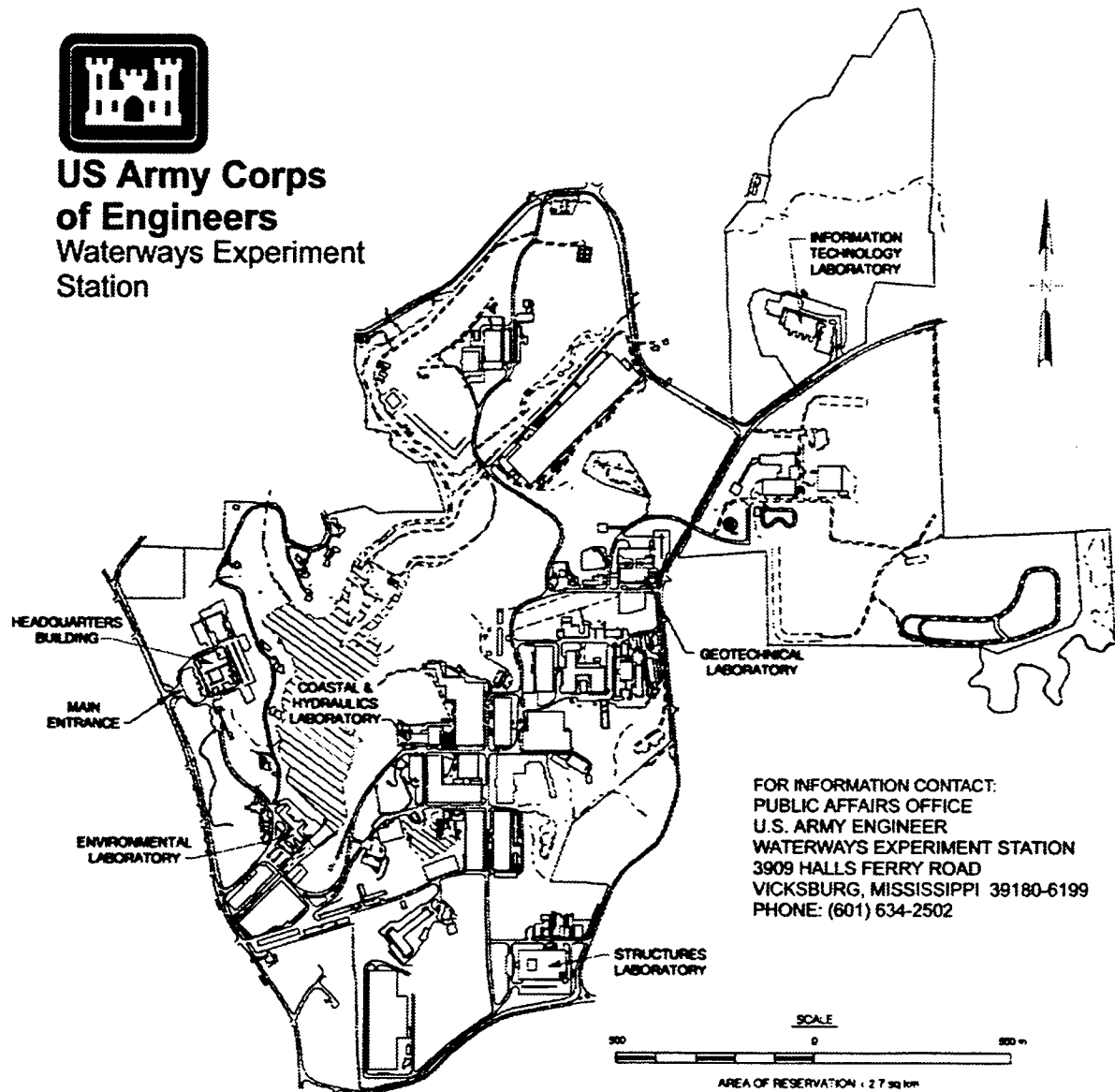

FOR INFORMATION CONTACT:  
PUBLIC AFFAIRS OFFICE  
U.S. ARMY ENGINEER  
WATERWAYS EXPERIMENT STATION  
3909 HALLS FERRY ROAD  
VICKSBURG, MISSISSIPPI 39180-6199  
PHONE: (601) 634-2502

### Waterways Experiment Station Cataloging-in-Publication Data

Technologies for improving the evaluation and repair of concrete bridge decks : ultrasonic pulse echo and polymer injection / by A. Michel Alexander ... [et al.] ; prepared for U.S. Army Corps of Engineers.

280 p. : ill. ; 28 cm. — (Technical report ; CPAR-SL-98-1)

Includes bibliographical references.

1. Bridges, Concrete — Evaluation. 2. Bridges — Floors — Evaluation. 3. Bridges — Maintenance and repair. I. Alexander, A. Michel. II. United States. Army. Corps of Engineers. III. U.S. Army Engineer Waterways Experiment Station. IV. Structures Laboratory (U.S. Army Engineer Waterways Experiment Station) V. Construction Productivity Advancement Research Program (U.S.) VI. Series: Technical report (U.S. Army Engineer Waterways Experiment Station) ; CPAR-SL-98-1.

TA7 W34 no.CPAR-SL-98-1

# Contents

---

Preface .....	vii
Conversion Factors, Non-SI to SI Units of Measurement .....	viii
1—Introduction .....	1
Background .....	1
Construction Productivity Advancement Research Program .....	2
Objective from CPAR-CRDA .....	2
Product Description from CPAR-CRDA .....	2
Overview of Nondestructive Evaluation Systems and Ultrasonic	
Pulse Echo .....	3
Current practice .....	3
Limitations of Old UPE system .....	4
Old versus proposed UPE system .....	5
Old UPE system versus radar .....	5
Old UPE system versus chain drag .....	6
Benefits of new UPE system .....	6
Scope of UPE development .....	7
Overview of Proposed Polymer Repair Technique (PORT) System ...	7
Introduction .....	7
Proposed research tasks of PORT system .....	8
Organization of Report .....	9
2—Development of UPE System .....	11
New Improved Transducer .....	12
Matching of acoustic impedances .....	12
Construction and testing .....	13
Improved directivity .....	14
Rolling Pond .....	14
Rapid measurements .....	15
Air film reduces echo strength .....	16
Air brush .....	16
Energy isolator .....	16
Water reservoir .....	17
Other features of rolling pond .....	17
Ray-Based Model and Physical Models .....	18

Bridge-deck information . . . . .	19
Physical-model construction . . . . .	19
Real-world delaminations. . . . .	19
Ray-Based Software Model . . . . .	20
Identification of unwanted modes . . . . .	20
P-wave time of arrival . . . . .	20
PS-wave and 2S-wave . . . . .	21
Approach . . . . .	21
Simplified model . . . . .	22
Model calibration . . . . .	22
Model testing . . . . .	22
Data Acquisition and Presentation of Results . . . . .	22
Data acquisition . . . . .	22
Presentation of results . . . . .	23
Split-Spectrum Processing . . . . .	24
Digital signal processing . . . . .	24
Time invariant noise . . . . .	25
Frequency-dependent noise . . . . .	25
SSP implementation . . . . .	25
SSP of data . . . . .	26
Artificial Neural Networks . . . . .	26
Interpretation of signals . . . . .	26
Influence of concrete on stress waves . . . . .	27
Elimination of expert . . . . .	27
Expert System for UPE . . . . .	28
Results (Laboratory and Field) . . . . .	28
Laboratory experiment . . . . .	28
Field tests . . . . .	29
<b>3—Development of Polymer-Injection System . . . . .</b>	<b>31</b>
Literature Review . . . . .	31
Extent and causes of bridge-deck deterioration . . . . .	31
Characteristics of concrete . . . . .	32
Bridge-deck deterioration . . . . .	33
Analysis of survey results . . . . .	36
Materials and Equipment Specifications . . . . .	40
Material specifications . . . . .	40
Equipment specifications . . . . .	47
Laboratory Evaluation of Polymer Materials (Phase I) . . . . .	50
Introduction . . . . .	50
Research plan . . . . .	50
Preparation of specimens . . . . .	51
Laboratory tests . . . . .	54
Test results and calculations . . . . .	56
Conclusions . . . . .	71
Laboratory Evaluation of Polymer Materials (Phase II) . . . . .	71
Details of test specimens and observations . . . . .	72
Tensile test results . . . . .	73

Conclusions . . . . .	73
System Procedures . . . . .	73
Procedures for Category-I sealer healer . . . . .	76
Procedures for Category-II surface coating . . . . .	79
Procedures for polymer injection . . . . .	82
Demonstration Projects . . . . .	86
Description of bridges . . . . .	87
Strategies for the demonstration projects . . . . .	88
Application of material . . . . .	89
Project monitoring . . . . .	92
Conclusions . . . . .	92
Laboratory Analysis of Demonstration Projects . . . . .	92
Projects (deck cores) . . . . .	92
Tensile testing . . . . .	93
Permeability testing . . . . .	94
Results of evaluation of bridge-deck cores at USACE Laboratory . . . . .	97
Cost-Analysis for Injection/Sealing . . . . .	99
Cost-analysis assumptions . . . . .	99
Explanation of cases for cost evaluation . . . . .	101
Conclusions from cost analysis . . . . .	103
Knowledge Based Expert System for PORT system . . . . .	103
4—Conclusions and Recommendations . . . . .	106
SUPERSCANNER . . . . .	106
Conclusions . . . . .	106
Recommendations . . . . .	109
PORT System . . . . .	110
Conclusions . . . . .	110
Recommendations . . . . .	112
Systems Combined . . . . .	113
5—Commercialization and Technology Transfer Plan . . . . .	114
References . . . . .	116
Figures 1-79	
Appendix A: Summary of Literature Review . . . . .	A1
Appendix B: Polymer-Injection/Ultrasonic Pulse-Echo System for Concrete Bridge Repair . . . . .	B1
Appendix C: Project Participants . . . . .	C1
Appendix D: Guide Specification Category I . . . . .	D1
Appendix E: Design Considerations . . . . .	E1
Appendix F: Contrast of Rolling-Pond and Sliding Systems . . . . .	F3
Appendix G: Split-Spectrum Processing . . . . .	G1
Appendix H: Artificial Neural Networks . . . . .	H7

**Appendix I: Expert System for UPE . . . . . I5**  
**Appendix J: Petrographic Examination of Concrete Core Samples . . . . . J1**  
**SF 298**

# Preface

---

This report was prepared at the Structures Laboratory (SL), U.S. Army Engineer Waterways Experiment Station (WES), under the sponsorship of the Headquarters, U.S. Army Corps of Engineers (HQUSACE), as part of the Construction Productivity Advancement Research Program. The investigation reported in this document was conducted under a Cooperative Research and Development Agreement between WES and Nebraska Technology Development Corporation. The HQUSACE Technical Monitors were Messrs. M. K. Lee (CECW-EG), Paul Tan (CECW-ED), and Daniel Chen (CEMP-ET).

Two products/systems of widely different technologies were developed in this project. Together these two products/systems provide an overall system for advancing the state of the art for the evaluation and repair of concrete bridge decks. The investigation to develop the polymer-injection system was performed by the University of Nebraska, and the investigation to develop the SUPERSCANNER was performed by WES. The project started in March 1994 and ended in August 1997.

The study was conducted under the general supervision of Mr. Bryant Mather, Director, SL; Mr. John Ehrgott, Assistant Director, SL; and Dr. Paul F. Mlakar, Sr., Chief, Concrete and Materials Division (CMD), SL. Mr. William F. McCleese was the CPAR point of contact at WES. Mr. A. Michel Alexander, CMD, was the Principal Investigator of this work unit. Mr. Alexander prepared this report with the assistance of Mr. Richard W. Haskins, Information Technology Laboratory, WES, and Mr. Robert Cook, University of Nebraska Center for Infrastructure Research. Mr. Dan Wilson, CMD, assisted in the WES laboratory work.

The investigation was conducted by Mr. Cook and Mr. Mantu Baishya of the University of Nebraska of UNL, and Mr. Michael Kelly of the U.S. Army Engineer District, Omaha, and by various industry participants.

At the time of the publication of this report, Dr. Robert W. Whalin was the Director, WES. COL Robin R. Cababa, EN, was the Commander.

*The contents of this report are not to be used for advertising, publication, or promotional purposes. Citation of trade names does not constitute an official endorsement or approval of the use of such commercial products.*

# Conversion Factors, Non-SI to SI Units of Measurement

---

Non-SI units of measurement used in this report can be converted to SI units as follows:

Multiply	By	To Obtain
cubic feet	0.02831685	cubic metres
cubic yards	0.7645549	cubic metres
Fahrenheit degrees	5/9	Celsius degrees or kelvins <sup>1</sup>
feet	0.3048	metres
gallons (U.S. liquid)	3.785412	litres
horsepower (550 foot pounds (force) per second)	745.6999	watts
inches	25.4	millimetres
Rayls	1	kg/s m <sup>2</sup>
miles (U.S. Statute)	1.609347	kilometres
pounds (force) per square inch	0.006894757	megapascals
pounds (mass)	0.4535924	kilograms
pounds per cubic yard	5.932	kilograms per cubic metre
square feet	0.09290304	square metres
square inches	64.516	square millimetres
yards	0.9144	metres

<sup>1</sup> To obtain Celsius (C) temperature readings from Fahrenheit (F) readings, use the following formula: C = (5/9) (F - 32). To obtain kelvin (K) readings, use K = (5/9) (F - 32) + 273.15.

# 1 Introduction

---

## Background

Approximately 34 percent of the 600,750 bridges on the public roads in the United States need repair or replacement. The funds required to undertake such a program are staggering: conservative estimates are \$12.4 billion for the Federal-aid system and \$10.6 billion for the off-system bridges. It has been said that the transportation system is deteriorating faster than it is being constructed and maintained.

Although many of the bridges identified as being structurally deficient or functionally obsolete are older structures, there is equal concern for the premature deterioration of newer structures. The bare pavement policy adopted by many states in the early and mid-1960's coincided with the rapid expansion of the interstate network. Consequently, the number of structures increased substantially because of new interchanges and grade separations with secondary highways. Many of these structures are large, and many are located in urban areas where traffic densities make maintenance operations difficult. The majority of these new structures were designed and built to specifications that have subsequently proven to be inadequate. Decks only a few years old are showing signs of distress. The estimated cost of repaving and upgrading structures on the interstate system alone exceeds \$2 billion. Engineers continue to search for methods of obtaining durable bridge decks while the problem continues to become more urgent.

Although concrete bridge decks undergo a variety of detrimental environmental attack mechanisms, the primary type of deterioration is delamination, a condition where part of the deck splits into two thinner layers. Often managers do not approve a restoration to the bridge deck until the deterioration is clearly visible on the surface. By then the deck has deteriorated to the point where maintenance and repair are not options. Therefore, overlays or removal and replacement of the bridge deck have taken precedence over maintenance and repair techniques. The former two procedures require a large expenditure and disrupt traffic for extended periods of time. Bridge decks need to be evaluated before the moribund or post-mortem stage so that maintenance and repair techniques can be implemented.

Ultrasonic through-transmission systems (American Society for Testing and Materials (ASTM) ASTM C 597 (ASTM 1996<sup>\*</sup>) have been employed to evaluate concrete for over 40 years and are available commercially. Ultrasonic pulse-echo (UPE) systems to evaluate concrete have appeared on the scene only in the last few years and are not yet available commercially. By development of a new nondestructive evaluation (NDE) system for concrete, a UPE technology whose special attribute is high resolution, delaminations in bridge decks can be detected prior to the stage of serious deterioration and can be repaired by means of a polymer-injection repair technique. This would allow significant cost savings and less traffic disruption.

### **Construction Productivity Advancement Research Program**

In response to the need for improved evaluation and repair systems for concrete, a research project was conducted as part of the U.S. Army Corps of Engineers' Construction Productivity Advancement Research (CPAR) Program. Two products of widely different technologies were developed in this project and together provide an overall system for advancing the state of the art for evaluation and repair of concrete bridge decks. The investigation for developing the polymer-repair technique (PORT) was performed by the University of Nebraska, and the investigation for developing the UPE system was performed by the U. S. Army Waterways Experiment Station (WES). Both parties (along with numerous industry participants) cooperated to develop a comprehensive bridge-deck repair system that will produce significant cost savings while minimizing downtime and traffic-control problems. The research was conducted under a Cooperative Research and Development Agreement (CRDA).

### **Objective from CPAR-CRDA**

The objective of this project was to develop a comprehensive system using a PORT composed of equipment and procedures necessary to inject low-viscosity polymer materials into drilled openings (ports) leading to cracks in the concrete bridge deck and to package an NDE system, a UPE device, in a compact field unit for the detection of both sound and defective concrete.

### **Product description from CPAR-CRDA**

The product will consist of two primary units: the PORT system for making the repairs and the UPE echo system for determining the location of deteriorated concrete. The PORT system will consist of a number of features: cleaning, drilling, polymer injection, flood coating, and an on-board computer to aid the operator in the procedure for making the repair. The UPE system

---

\* All ASTM citations are given in the References at the end of the text.

will combine numerous features to aid in the diagnostic work: an on-board microprocessor with artificial neural network (ANNs) algorithms for interpreting the pulse-echo signals and a knowledge-based expert (KBES) system for leading the operator through the diagnostic procedure, a floppy disc system for data storage, and the latest state of the art in piezoelectric transducers designed to be compatible with the acoustic properties of concrete.

## Overview of Nondestructive Evaluation Systems and Ultrasonic Pulse Echo

### Current practice

Numerous techniques and equipment are used to detect delaminations in concrete bridge decks. No one device exhibits all the characteristics of an ideal measurement tool. The following measurement systems are used currently to detect delaminations in bridge decks.

**Radar.** Radar, an electromagnetic time-of-flight technique, is used to detect delaminations. Radar, like all of the techniques, has some merits as well as limitations. Data acquisition is very rapid, but resolution is poor. Radar requires a highly trained person to operate the equipment and to interpret the meaning of the radar signatures. Radar is especially useful for asphalt overlays as the high internal damping of the asphalt limits the penetration of acoustic energy more than the radar. In about 20 min, 1,000 ft<sup>2</sup>\* of bridge deck can be covered. The equipment is expensive and usually requires a van to be transported. The presence of steel reinforcement can obscure the information about the concrete, and the moisture level in the concrete strongly affects the response.

**Chain drag.** Currently, the most common technique used to detect the presence of delaminations is the chain drag (ASTM D 4580). The chain drag, a low-frequency acoustic impact technique (sounding), is used by 95 percent of the State Department of Transportation (DOTs). It is inexpensive, lightweight, and simple to use. However, the depth of the delamination cannot be determined with the device, and lateral resolution of the delineated boundary of the delamination may not be any better than 6 in. The method works only for delamination no more than 3 or 4 in. below the surface. It is subjective, based on the operator having an ear for distinguishing between the ringing and hollow sounds that undelaminated and delaminated concrete make, respectively. Also, in the presence of high traffic in an adjacent lane, the noise might influence what can be heard. The locations of the delaminations are usually drawn on the surface of the bridge deck with chalk, and a paper drawing is made of the result. In about 4 hr, 1,000 ft<sup>2</sup> of deck can be evaluated.

---

\* A table of factors for converting non-SI units of measurement to SI units is given on p. viii.

**Thermography.** Thermography operates on the principle of detecting the differences of surface temperature across a body. Sound areas will cool faster than delaminated areas and hence have a lower temperature. Resolution is very poor, but data acquisition can be performed without disrupting traffic. This type of evaluation technique is limited in that it is sensitive to surface properties such as texture and color. Shadows on the deck can affect results. Tests can be made only during the day when temperature gradients have their highest value (usually early morning and late evening). The equipment is expensive and requires extensive training to use. In about 20 min, 1,000 ft<sup>2</sup> of deck can be evaluated. The equipment would normally be operated from a van.

**Impact echo.** This is an acoustic impact technique based on setting up a resonant condition between the top surface of the concrete and the interior interfaces of interest. It generally operates in the sonic frequency range but may overlap into the ultrasonic range for defects at shallow depths of less than 1 in. It has sufficient resolution for an accurate depth determination, but the lateral resolution is less. Taking measurements is fairly time consuming. Flexural vibrations (sounding) can interfere with longitudinal resonances. One can cover a 1,000 ft<sup>2</sup> of deck in about 2 hr with measurements made on a 1-ft grid.

**UPE.** UPE is an acoustic technique with high resolution. It operates in the ultrasonic range at a center frequency of 200 kHz. The old system as it existed at the beginning of this project was as slow as the previous technique and might take a half day to cover 1,000 ft<sup>2</sup> of bridge deck with a grid pattern of 1 ft. The system required a significant amount of training to use — both to operate the equipment and to interpret echo records. The equipment was expensive and bulky.

**Coring.** Destructive methods of evaluating a concrete structure include making laboratory evaluations on concrete samples taken from drilled cores in the structure. Even though the removed concrete volume is later filled with new concrete, the structure is weakened from this type of destructive evaluation method. Also, the aesthetics are disturbed. Evaluation using cores is a localized method of evaluation that will provide information only on the specific location from which the core is taken, thus providing an often inaccurate overall assessment of the condition of the entire structure.

### **Limitations of Old UPE system**

UPE systems are used in almost all materials except concrete. The inhomogeneity of concrete and its unique acoustical properties interfere significantly with various wave types. Therefore, no commercial unit is available for concrete.

The old WES-prototype UPE system had a number of limitations. The system was not specifically designed for evaluating concrete bridge decks. A

viscous liquid couplant was required to be smeared on the concrete surface and the transducers pressed onto this liquid, which considerably slowed the measurements. No method had been implemented for transforming groups of single measurement records into a compiled form to produce an image. The angle of the maximum energy leaving the transmitter transducer was not directed toward the receiving transducer; the system had no software for signal-to-noise ratio (SNR) enhancement; the system had no computer guidance on how to perform the measurement procedure; and there was no computer guidance on how to interpret the signal patterns.

### **Old versus proposed UPE system**

In the late 1980's, WES developed a laboratory prototype UPE system for the detection of defects in concrete (Thornton and Alexander 1987). This system demonstrated that UPE signals can contain discriminating information about the type and extent of defects in concrete. Although the hardware performed well, the system was not user-friendly and required a highly trained person to operate the equipment and interpret the signals. The UPE system, as it existed in laboratory prototype form, was heavy, bulky, and complicated, and measurements were slow. Also, analysis had to be performed by computer, offline and offsite. The proposed field system was to be more accurate, faster at acquiring data, more prompt in displaying results and capable of displaying the results onsite, more efficient by the installation of an onboard computer, more user-friendly, and more compact.

### **Old UPE system versus radar**

The resolution is higher (short wavelength) with the UPE system than with radar. Resolution is inversely proportional to wavelength. The effective wavelength of UPE is only about 1 in. as compared with radar, which is about 5 in. for normal frequencies of operation. Attenuation of ultrasonic energy is high in concrete, but the attenuation of electromagnetic energy is even higher. Reducing the center frequency of operation to reduce the attenuation causes an increase in the wavelength. With the UPE system, the presence of steel does not obscure information about the macro-structure of concrete as radar does. High moisture content does not change the acoustic velocity of propagation as radar does. Wet and dry concrete can alter the velocity about 50 percent with radar but only alters the velocity about 5 percent with UPE. Also, UPE offers the possibility of earlier detection due to its high resolution, and that allows preventative maintenance.

The benefit of higher resolution is that the detection of flaws can be made earlier before the bridge deck reaches the moribund or postmortem stage. The benefit of early detection is that the repairs can be made by a repair technique such as polymer injection. Polymer injection permits rapid repair relative to the time required for overlays and deck replacement and the possibility of

maintenance rather than replacement. Rapid repair is a necessity because of the public's intolerance for closing roads and bridges.

### **Old UPE system versus chain drag**

The benefits of UPE evaluation as contrasted with the chain drag are the following: the chain drag is subjective, based on the ability of the technician to hear pitches sometimes in the presence of traffic noise; the UPE system is objective, based on impartial numbers rather than indefinite sounds; and the chain drag, unlike the UPE system, does not provide the depth of the delamination. Boundary lines drawn of the delaminated area is a *maybe* with the chain drag rather than a clearly defined *yes* with UPE. Boundary lines of the delamination can be determined within a couple of inches with the UPE system.

### **Benefits of new UPE system**

Numerous enabling technologies were to be embodied in a single system to develop a unique nondestructive high-frequency, high-resolution UPE technology for assessing the condition of concrete bridge decks. The new system would continue to make high-resolution measurements at a center frequency of 200 kHz enabling a narrow beam with directivity. The proposed system should provide the following benefits:

- a. The UPE system would produce numbers rather than sounds and should be unaffected by external noise, thus permitting all operators to obtain objective results.
- b. Information about the concrete would be gathered from directly below the transducers rather than in a wide region around the transducers. The interrogation energy would be in a directed beam. The beam would not be omnidirectional like that from impacts.
- c. The method of delivery of energy used to interrogate the concrete would be controlled electronically. Therefore, the firing of the transducers and the consistency of the energy characteristics would be better controlled than by conventional methods.
- d. The results of UPE measurements would not be dependent on geometry as is the case with vibratory and impact techniques.
- e. Operators could be easily trained to use the equipment.
- f. The data would be compatible with a digital computer and permit the use of applicable software packages.
- g. The system would not only have the ability to detect the presence of delaminations, but could also determine if the delaminations are air- or

water-filled, the angle of orientation, and the depth of the delaminations. Also, the system would continue to have the potential to detect honeycombing, foreign objects, reinforcing bars, microcracks from alkali-aggregate reaction, freezing-and-thawing damage, fire damage, macrocracks, debonding of concrete from reinforcing bars, and debonding of aggregate from the cement paste.

### **Scope of UPE development**

The scope of the UPE development consisted of the following tasks: to build a new improved set of transducers to improve signal quality, to build a watertight moving frame which will carry a layer of water down the deck at a fast rate, to build an archive of laboratory concrete models and a ray-based computer model to improve signal identification in the laboratory, to use hardware and software that will acquire data at a rapid rate, to combine hundreds of signals into a depth profile chart to improve the ease of interpretation of the results, to evaluate and implement the split-spectrum process (SSP) algorithm to reduce material noise, to train ANNs to recognize signal patterns and hence certain types of deterioration to develop computer interpretation of signals, to develop an expert system to guide the operator in the use of the UPE system, and to evaluate the capability of the system in the laboratory and field.

Not only was the goal to come up with specifications for a new system, but to build an effective prototype for bridge-deck inspections that would be worthy of commercialization.

## **Overview of Polymer Repair Technique (PORT) System**

### **Introduction**

The main objective of the PORT system research was to develop a comprehensive system using a PORT comprising equipment and procedures necessary to inject low-viscosity polymer materials into drilled openings at crack locations in the concrete bridge deck.

This research was to merge the rapidly developing technologies of polymer materials with field application techniques to strengthen and rehabilitate existing bridge decks with minimal interference with traffic. The application of this type of rehabilitation scheme was to serve two basic functions. First, a polymer would be injected to act as a binder for separated concrete (both micro and macro), and second, a polymer flood coat would be used to fill surface and below-surface void spaces of the nondistressed concrete. The first function would re-establish a degree of the original structural integrity, and the second function would seal the structural concrete mass against environmental attack.

In the beginning of the project, an extensive literature review was to be performed to determine the state-of-art status of this repair process. A questionnaire survey was to be conducted to extract ideas from the professionals in this field. Laboratory investigations were to be performed to evaluate the performance of polymer materials. Available equipment was to be modified to suit this repair technique.

### **Proposed research tasks of PORT system**

The following project tasks were to be pursued for development of the PORT system:

- a.* Collection and review of current domestic and foreign literature, research findings, performance data, and practices related to rehabilitation and strengthening of concrete bridge decks using polymer injection and in situ impregnation. This information was to be assembled from published literature, unpublished reports, contact with state transportation agencies via telephone, correspondence, survey questionnaires, and other sources.
- b.* Development of injection port drilling and vacuum cleaning equipment techniques, collection and review of domestic and foreign publications on the existing methods for injection port drilling and cleaning, and selection and evaluation of suitable method(s) for injection port drilling in concrete bridge decks.
- c.* Development of mechanized mixing and injection equipment and techniques, and review and evaluation of existing method(s) for two-part polymer mixing and injection into cracks in concrete structural elements using external pressure, and any other techniques used in the past.
- d.* Development of mechanized deck surface cleaning equipment, and review and evaluation of the suitability of existing practical methods of bridge deck surface cleaning. (The review would include both domestic and foreign literature on different types of equipment.)
- e.* Testing and evaluation of strengthened concrete slab and beam elements for short- and long-term behavior to simulate site-specific conditions. Rehabilitation and strengthening of concrete bridge decks using polymer injection and in situ impregnation operations were to be conducted on existing bridges as demonstration projects after confirmation on laboratory model evaluations. Deteriorated bridge decks which required rehabilitation were to be identified within a number of states for demonstration projects. The proposed method was to be conducted in collaboration with the appropriate transportation authorities. The results of the polymer-injection rehabilitation were to be compared with conventional overlay methods including cost considerations. The

laboratory evaluations were to complement the evaluations on strengthened concrete specimens for short- and long-term behavior to simulate site-specific conditions. Based on the engineering and scientific principles, a high-caliber investigation was to be conducted on the physical, chemical, and mechanical properties of polymer injected/coated concrete. Concrete of three different strengths representing bridge decks in the range of 3,400 to 4,500 psi were to be used for the laboratory evaluations.

- f.* Development of a KBES for use in the evaluation of existing bridge decks and recommendation of the suitable rehabilitation process.

The development of the KBES was to be conducted in two stages:

- a.* Development of the prototype system.
- b.* Development of a complete PC-based expert system. Gathering the knowledge for this KBES was to require two steps. In step one, the university investigators would study and review field and research data. In step two, the university investigators would consult with bridge experts to determine the facts and relationships that were important in the decision tree of the expert system. The KBES, with the help of the expert knowledge, would analyze the field data and make recommendations for the following:
  - The best rehabilitation procedure to be used.
  - Cost factors and parameters.
  - The approach for deck cleaning, injection port drilling.
  - A suitable polymer-injection procedure.

## Organization of Report

A brief discussion of the overall research and development effort and the two systems which can be combined into one total system has been summarized in Chapter 1. Chapter 2 describes the ultrasonic principles used in designing and constructing an improved UPE system and the major stages of its design and construction. Chapter 2 also documents the important advancements that evolved from the laboratory and field development of a new UPE system, called the SUPERSCANNER (patent pending), an acronym for Scanned Ultrasonic Pulse-Echo Results for Site-Characterization of Concrete Using Artificial Neural Networks and Expert Reasoning. Documentation describing the development of the PORT system is provided in Chapter 3, which also presents the literature review, survey results, laboratory evaluation, and description of different procedures and demonstration projects. Because the two technologies for the UPE and PORT systems are significantly different, the two studies are separated in this report to enhance readability. The conclusions and recommendations for both subsystems and the system as a whole are

treated in Chapter 4. The commercialization of both subsystems are treated together in Chapter 5.

Appendix A includes a literature review, and Appendix B provides additional information about the PORT/UPE system for concrete bridge repair. Appendix C names the project participants. Guide specifications for Category I are given in Appendix D. Design considerations of transducers which deal with the physics of ultrasonics are described in Appendix E, and the contrast of the rolling pond and a typical sliding couplant system is given in Appendix F. The principle of the split-spectrum algorithm is described in Appendix G, a laboratory study of ANNs is given in Appendix H, and a library study of an expert system is included in Appendix I. Appendices H and I contain two significant areas of development that were not brought fully to completion in this investigation: ANNs and KBESs for use with the UPE system. Appendix J contains the results of petrographic examinations of concrete core samples.

## 2 Development of UPE System

---

Five significant areas of improvement in the development of a UPE system are discussed in this chapter: (a) new transducers to improve signal quality; (b) a watertight moving frame, which encloses the transducers, to improve the rate and density of data acquisition; (c) a computer model and physical models used in conjunction to improve identification of desirable and undesirable signals; (d) a method for combining individual signals into a depth presentation plot to simplify interpretation of the condition of the bridge deck; and (e) a new type of signal-processing algorithm for reducing material noise. The results are given for both laboratory and field measurements with the new system. The steps of the development are organized in a descending order of importance.

The technology does not currently exist to develop an ideal instrument without some limitations, but in order to know how to measure the progress in the development, it is important to know the difference between the present state-of-the-existing UPE measurement system and the final state-of-an-ideal UPE measurement system. Some of the limitations of the UPE system as they existed at the beginning of this project have been described in Chapter 1. The following are the target characteristics of an ideal NDE measurement technique that would be effective in evaluating delaminations in concrete bridge decks:

- a.* A system with high accuracy, high resolution, and sufficient penetration.
- b.* Rapid data acquisition (ability to gather data on a bridge deck in the shortest time possible to minimize disruption of traffic).
- c.* Sufficient measurement criteria that can be used to interpret most signal patterns.
- d.* Presentation method to combine signals such that a depth profile of the delaminations of a large portion of bridge deck can be seen.
- e.* Reduction of material noise by digital signal processing or other means.

- f.* Results that can be obtained in real-time or at least onsite.
- g.* User friendliness (computer will direct operator on test procedure).
- h.* Efficient (one-man operation).
- i.* Computer recognition and interpretation of signal patterns (elimination of the expert).
- j.* Validation of system in laboratory and field.

## **New Improved Transducers**

As WES researchers had gained new knowledge about transducer design since the construction of the original transducers under a previous research program, new ultrasonic transducers that performed better than the prior system were to be designed and built. The development of a UPE system is analogous to the development of a television (TV) receiver. The first priority for both systems is that the first stage of development produce an adequate signal (picture and sound for TV, echo for UPE) before the development of other features are initiated. Just as the development of an aesthetic cabinet to house the TV, a device to operate the TV remotely, hardware and software to enable simple operation, etc., are secondary issues in developing a TV, so are the computer guidance on the test procedure, computer interpretation of signal patterns, miniaturization of equipment, simplicity of operation, portability, etc., in the development of the UPE system. Therefore, the stages of development are presented in a descending order of importance starting with transducer (signal) development.

### **Matching of acoustic impedances**

The new improved transducers for the UPE system are shown in Figure 1. Improvements were made in the quality and efficiency of energy transmission and reception by matching the acoustic impedances of the transducer faceplate materials with each other and with the concrete. Impedance matching is accomplished by using a material whose impedance permits a smooth transition from one material to the other. The material inserted in between the other two materials has an impedance that is the geometric mean (square-root of the product) of the surrounding material impedances. The piezoelectric material was matched to the lead glass, the lead glass to the granite, and the granite to the concrete. The impedance of the piezoelectric elements was 20 megarayls, the impedance of the lead-glass was 17, the impedance of the granite was 13, and the impedance of concrete is about 10. (See "Reflection, Refraction, and Mode Conversion," Appendix E, for an explanation of acoustic impedance and acoustic impedance matching.)

Calculations were performed to determine the optimum acoustic impedance and thickness for transducer faceplate materials for optimizing energy transmission into the concrete and reception out of the concrete for the pitch-catch system. This two-transducer configuration uses one transducer to pitch, or transmit, stress waves and another transducer to catch, or receive, the backscattered stress waves. Granite was chosen for the faceplates both for the transmitter and receiver transducers. Lead-flint glass was obtained for the intermediate faceplate between the piezoelectric elements and the granite faceplate. The faceplates for both materials were designed in thickness for quarter-wavelength matching to improve the transmission and reception quality. Figure 2 shows the piezoelectric elements, lead-glass layer, and granite faceplate during construction.

### Construction and testing

A methyl-methacrylate plastic housing was built for protecting the transmitter and receiver transducers against impact and moisture and to prevent coupling unwanted acoustic energy from the water (Figure 3a). Various types of adhesives for bonding the various transducer materials were examined, and the proper types were chosen. The lead-glass faceplate material has gold electrodes sputtered on the surface for making the electrical connections to the piezoelectric elements. The piezoelectric elements had silver electrodes factory-sputtered on them.

New mosaic transducers were fabricated from four 50- by 50-mm pieces and two 50- by 25-mm pieces of lead metaniobate piezoelectric elements for total dimensions of 100 by 125 mm each. A minimum area was chosen for the transducers that would still permit an approximate collimation of the beam rays (Figure 3b). (See "Transducers Characteristics," Appendix E, for an explanation of collimation and "Other Sources of Attenuation," Appendix E, for an explanation of divergence.)

Lead metaniobate is ideally suited for concrete ultrasonic testing because it exhibits both a low  $Q$  (about 2) and a low planar coefficient ( $< 0.1$ ). The low  $Q$  means that the ring-time is low, and the low planar coefficient means that the transverse generation of undesirable energy is low. This latter property reduces the production of surface waves and shear waves created by mode conversion.

The use of transducer backing materials for providing additional damping was explored but not implemented. Tests made in the laboratory showed a merely moderate improvement in damping at the expense of a sensitivity loss. A preferred 200-kHz center frequency was selected based on a trade-off between penetration depth (a function of losses from scattering) and resolution (a function of wavelength).

The latest in piezoelectric technology was purchased for the transducers. The material used was K-81 manufactured by Kermos, Inc. The piezoelectric

elements were rated for a Curie temperature at 400 °C. (The Curie temperature is the temperature at which the piezoelectric elements can become depolarized.)

The new transducers were first tested on concrete in a stationary measurement. Water was used as a couplant between the transducers and the concrete surface. Acrylic side panels were bonded around the perimeter of each 2-ft<sup>2</sup> concrete model to contain the water, and the space was filled to a depth of about 1 in. for performing laboratory experiments (Figure 1).

### Improved directivity

Transducers were built with angled faceplates to improve the signal strength for the pitch-catch configuration. Transducers with angled faceplates deliver and receive the maximum energy at some angle  $\phi$  (Figure 4b). The angle  $\phi$  depends on the angle of cut of the wedge for a given UPE system. The transducer separation distance, the depth of the desired echo, and the length of the transducers are variables that determine the angle of cut of the wedge. Figure 4a shows a typical beam pattern for a transducer with a parallel faceplate. Maximum energy occurs at 0 deg. Note that the transducer cannot supply as much signal strength at an angle of 0 as it can at  $\phi$  deg. By incorporating an angled faceplate onto the transducers, the beam pattern can be rotated, as shown in Figure 4b, to maximize the energy at an angle of  $\phi$ . The faceplates of the transducers were cut to maximize the transmission and reception of energy at a transducer separation of 1 in. and a backwall reflection of 8 in. from a typical bridge deck. Increasing the signal strength by means of an angled faceplate is an important improvement, both for the transmitting and the receiving transducers.

During field testing, it was discovered that the high summertime temperatures in Mississippi were causing a loss of sensitivity in the transducers. Since the piezoelectric elements have a very high Curie temperature, this loss was not due to the elements themselves. It was believed that the epoxy used to bond the lead glass to the granite faceplate was failing because of different temperature coefficients between the glass and granite. Metal foil reflection covers on the transducers helped reduce the problem.

### Rolling Pond

This section deals with the development of the rolling pond, a feature which permitted UPE data to be gathered more rapidly than had been done previously.

UPE measurements cannot be made by simple contact of the transducers with the concrete surface. Very little ultrasonic energy will penetrate the air gap between the transducer and the concrete surface due to the large ratio of the acoustic impedance of the piezoelectric material and air (700,000 $\times$ ).

(Optimum transmission and reception occur when the ratio is 1.) The low impedance of the thin layer of air between the transducer and concrete requires that the air interface be replaced with some liquid couplant having a higher impedance than air, an impedance that more closely matches that of the transducer and concrete. The couplant is normally viscous, and care must be taken to rotate and press the transducer down on the couplant so as to squeeze the air from the couplant material after it is spread onto the concrete surface. The method limits the speed of measurements as this process takes some time and the transducers must remain stationary during the period of data acquisition. From underwater UPE measurements made on a concrete wall in a marina a few years ago, WES researchers verified that water was an ideal ultrasonic couplant medium which could be used to improve the speed of measurements. Also, water is ideal because of its ready availability, nonexistent cost, and cleanup.

A rolling pond was developed to carry a small volume of water in which the transducers could lie and to permit an efficient transfer of acoustic energy from the transducers to the concrete and vice versa (Alexander, Grau, and Alexander 1995). The rolling pond consists of a metal frame with a rolling gasket which provides a sealed space that will maintain a water volume of about 2 L. The rolling pond and various accessories are shown in Figure 5. The damping effect of the soft closed-cell foam helps reduce the vibration of the transducers due to the rough concrete surfaces of bridge decks. The system is designed to be heavy so that an adequate sealing pressure is maintained. Eight pulleys located along the length of the belts help maintain a continuous seal between the soft foam and the concrete surface. As the device is moved over the concrete, the front and back rollers and the belts on the side move with each other so that foam wear is minimal. The components of the rolling pond frame are illustrated in Figure 6.

### **Rapid measurements**

The UPE system is a mobile, water-coupled system. A water layer maintains a continuous path for the UPE transmission of energy between the transducer and the concrete. The rolling pond overcomes a serious deficiency from the prior way that measurements were made: a stationary measurement performed using couplant grease. The water-coupled method provides a quantum leap in measurement speed. A water couplant between the transducer and the concrete is continuously maintained by the rolling pond while the system is in motion. Data can be continuously collected across a concrete surface, and the measurement density is unrestricted.

### **Air film reduces echo strength**

When water is initially poured onto a concrete surface, an air film forms on the surface (Figures 7 and 8). This air film significantly reduces the strength of the UPE signals. As the ultrasonic energy travels from the transmitter through the water (a) and encounters the air interface, a significant portion of the incident energy is reflected back into the water (b) rather than being transmitted through the air film and on into the concrete (c). In other words, an echo is created by the air interface. When a large percentage of the energy is reflected from the air film, then a low percentage is transmitted through the air film and into the concrete. This energy (d) is then reflected back toward the surface of the concrete from the interface of interest (delamination, backwall, etc.). This energy is further reduced when it encounters the air film again at the concrete surface (e) prior to reaching the receiving transducer. So, not only is the energy of transmission reduced, but also the energy of reception is reduced by the air film.

### **Air brush**

It is important to replace the air film with water to permit a greater transfer of energy into and out of the concrete. Echoes are unwanted from the surface of the air film as well as any location other than the flaw, delamination, backwall, etc.

Initially in the UPE development, measurements were made on concrete specimens while the transducers were stationary. While stationary measurements were being made in concrete with the transducers in about 1 in. of water, a film of air could be seen on the concrete surface when the observer looked at the concrete surface at the proper angle. It was discovered that one could sweep a fine-bristled brush across the surface of the concrete and the air would rise to the surface of the water layer. This phenomenon occurs because small bubbles are either dislodged from the surface or swept together into larger bubbles which quickly dislodge and rise to the surface. This procedure resulted in a considerable increase in signal strength. Therefore, when mobile measurements were begun, an oscillating spring-loaded brush (Figure 9) was installed in front of the transducers to remove the air. It is conservatively estimated that this resulted in at least a 70-percent increase in signal strength.

### **Energy isolator**

Unwanted stress wave energy can travel from the transmitting to the receiving transducer directly through the water layer and cause interference with the detection of body waves in the concrete. An energy isolator that prevents this occurrence was designed and installed between the transducers. An isolation device formed from a spring-loaded closed-cell foam strip was used to block ultrasonic energy traveling from the transmitter to the receiver

through the water. Sponges with wave-trapping geometries were also used to control ultrasonic reflections in the water. These sponges were placed in the water beside the transducers and helped reduce the amplitude of reflected ultrasonic energy trapped in the water layer. The sponges also helped reduce slosh from acceleration of the water in the rolling-pond system. Excessive slosh creates some low-frequency noise in the ultrasonic data. Both of these accessories are shown in Figure 9.

### **Water reservoir**

A water reservoir with float system was designed to supply water to the rolling pond. The rolling pond leaks at a slow rate for concrete with large cracks or rough surfaces, and a reservoir is needed to restore the loss of water. A float system provides a variable rate of water to the sealed space.

### **Other features of rolling pond**

Some other features possessed by the rolling pond are the following: supporting components that permit adjustment of angle, elevation, and separation of the transducers; winch and ramp to maneuver SUPERSCANNER; and an electrical/mechanical counter to control separation distance between measurements.

Vertical and horizontal positioning of the transducers within the rolling pond is accomplished by the adjustment of supporting nuts on threaded rods to set the proper gap between the transducers and the concrete surface. Wing-nuts on top of these rods allow for fine adjustment of the angle and elevation of both transducers (Figure 9). The aluminum frame of the rolling pond is slotted so that the transducers and supporting components can be suspended at various positions in the fluid bath. The slots in the frame also allow for the transducer separation distance to be varied. The ability to adjust transducer positions and angles is an important feature for optimizing the amplitude of desired reflections. The transducers are also spring loaded so that they will lift up should they accidentally strike an irregularity on the concrete surface.

The elevation of the transducers should be set so that their face is as close to the concrete surface as possible without the possibility of making contact with the surface. Rougher, more irregular surfaces may dictate higher transducer elevations. The angles of the transducers and separation distances are set so that reflections from the backwall face, up to the top reinforcement layer of the slab, are obtainable.

A winch and metal ramp were designed and installed into the instrumentation van for loading and unloading the rolling pond at the bridge site and for moving the rolling pond down the bridge deck during measurements (Figure 10).

The separation distance between measurements is controlled through means of a counter, which is rotated by one of the rollers of the rolling pond. When the counter reaches the set value, an encoder automatically triggers the pulser and oscilloscope and permits measurement data to be taken. Data can be collected at a density of up to 12 readings/in.

The separation distance between the rollers can be adjusted so that the belt tension can be maintained. See belt tension adjustment illustration in Figure 6.

Short scans down the deck can be made to calibrate the velocity of concrete from the backwall echo in those instances where the thickness of the concrete is known.

When not in use, the unit can be supported by blocks under the frame so that the foam on the rollers and belts is not deformed by prolonged compression.

Appendix F describes the contrast between the rolling pond couplant system and the sliding couplant system. The sliding couplant system is a patented system that also uses water, but the water is between the transducers and metal boiler pipe. The two systems are significantly different from each other.

The rolling pond component of the SUPERSCANNER is a novel ultrasonic coupling system for concrete. This component is composed of the following unique components: foam-covered tracks and rollers, air-removal brush, ultrasonic isolator and wave absorbers, and transducer suspension system. This coupling system has proven successful on both rough and grooved concrete surfaces. The rolling pond permits the data to be gathered at approximately 700× the rate of the old system. Also, the inclusion of graphics as an improved method to present the results of the diagnosis is made possible by the rolling pond as it enables the easy acquisition of hundreds of signals over a distance of a few feet.

## **Ray-Based Model and Physical Models**

Although numerous signal patterns can be recognized and interpreted, such as that from a backwall echo or a delamination, a number of types of deterioration occur in the field for which the signal feature has not been seen. Measurement criteria in this context are defined as the correlation of the UPE signal features to certain physical features in the concrete. Raw signals from UPE measurements on hardened concrete can contain a considerable amount of information about the characteristics of the concrete. For example, a UPE signal may contain information about defects, backwall location, reinforcing-bar location, aggregate type and size, and general mechanical properties. Besides the considerable amount of information contained in the signals, acoustical effects such as mode conversion and aggregate backscatter further complicate signal analysis.

## **Bridge-deck information**

Information was gathered from DOT personnel and others on the structural design parameters of bridge decks in order to construct realistic physical concrete models of bridge decks for evaluation in the laboratory. Dimensions for all the models were chosen to be 0.6 m<sup>2</sup> to prevent unwanted side reflections from interfering with the desired reflections from defects and the backwall. A concrete mixture that is typically used for bridge decks was chosen for the majority of the physical models.

## **Physical-model construction**

Tens of physical models, widely variable in their acoustic properties and incorporating artificially crafted defects, were constructed in the laboratory as calibration standards for developing UPE measurement criteria for the interpretation of the signal patterns from the concrete (Haskins and Alexander 1995). A series of concrete bridge-deck models were designed and constructed with varying thicknesses and surfaces that simulated smooth idealistic delaminations. The smooth surfaces allowed fundamental interactions between the ultrasonic energy and the concrete to be understood prior to evaluating more realistic delaminations. A store of calibration standards of sound and defective concrete specimens was fabricated for specifically developing measurement criteria in the laboratory (Figure 11). The specimens contained delaminated defects of various thicknesses, steel reinforcement, different aggregate type and size, an air/water-gap simulated defect of variable thickness, etc. A test bed was constructed for use in the laboratory to study the physical models (Figure 12).

## **Real-world delaminations**

Two innovative techniques were developed for simulating field-like delaminations of concrete. One technique was devised to load the hardened specimen in a certain way under a loading machine that caused the specimen to split into two layers and thus create a realistic delamination (Figure 13). Another technique was to spray and mix an admixture on the surface of the fresh concrete to retard hydration. The weak paste, which was only about 0.5 in. deep, was brushed away, exposing the aggregate and creating a delaminated-like surface. The surface aggregate for each specimen could then be roughed up to different degrees of coarseness with an impact hammer. All specimens were 2 ft<sup>2</sup> and varied in thickness from 0.5 in. to 9 in.

# Ray-Based Software Model

## Identification of unwanted modes

A mathematically deterministic ultrasonic software ray-based model (RBM) was written and designed to identify the various modes in echo events and eliminate the confusion from false signals that occur due to multiple reflections and mode conversions. The various modes that can be present in a signal are the following: the first reflection of the primary wave (2P), the second reflection of the primary wave (4P), first reflection of shear wave (2S), the first reflection of the primary wave and the mode-converted shear wave (PS), the second reflection of the primary and shear wave (2SP), and the Rayleigh (surface) wave (R) (Figure 14). The arrival location and separation distance of each type of wave on the surface of the concrete slab is not necessarily correct and in the right proportion, as the intention was to separate the path lines for distinct labeling. The RBM is used only during the development stage to improve the researchers' ability to identify events. The equations that describe the physics of wave interaction are: Snell's law, coefficient of relative reflection, sound pressure against distance, etc. See Appendix E for an explanation of each phenomenon.

Although the mathematical calculations are deterministically based, the parameters are empirically refined, based on measurements of physical models. It is next to impossible to estimate the amplitudes, phases, and arrival times without tweaking the parameters through actual measurements made on specimens of simple geometry and known properties.

Mode conversion (one wave type partly or completely changing to another) can occur when the propagated wave obliquely encounters another material that has a variation in acoustical impedance. Snell's law can be used to calculate the angles of reflected and refracted mode-converted waves. The parameters of this RBM program are then adjusted by comparing the calculated results from the model to the experimental results from laboratory specimens whose properties are well-known.

## P-wave time of arrival

The RBM uses vectors or rays to calculate the time of arrival (TOA) of the propagating waves of the UPE system. The TOA is determined by the equation  $t = S/v$ , where  $S$  is distance and  $v$  is velocity. Mathematical simulation starts with an initial P-wave originating from the transmitter and traveling into the concrete at a given velocity (Figure 14). The velocity in the actual physical model can be determined with the V-meter, an ultrasonic through-transmission device that measures the P-wave velocity through concrete. The path distance traveled is determined by the Pythagorean theorem, which is dependent on the depth of the reflecting interface and the separation distance of the two transducers. The RBM then calculates the time for the P-wave to leave the

transmitter, travel to the reflecting interface, and return to the surface to be detected by the receiving transducer. One should expect to find one event in the measured data that corresponds closely to this TOA. If so, this is the TOA of the 2P echo.

### **PS-wave and 2S-wave**

When the P-wave strikes the top surface of the concrete at an oblique angle, mode conversion occurs, and S- and R-waves are produced in addition to the reflected and refracted P-wave. The angles of refraction are determined by Snell's law, an equation given in Appendix E. Consider the P- and S-waves only. Using the equation mentioned above, the velocity of the shear wave is considered to be about 61 percent of the P-wave velocity. Then, both types of rays will reflect off the backwall (bottom surface) at their incident angle. The P-wave upon striking the backwall will again be mode converted, creating reflected S- and P-waves whose angles are again determined by Snell's law. In addition to the 2P-wave, there is now a PS- or SP-wave and a 2S-wave arriving at the receiver. If these amplitudes are sufficient to be seen in the signal record, one should see a PS and a 2S event in the measurement data. Because of their lower velocities, these events will occur after the arrival of the 2P-wave. So the RBM permits one to identify events in the time record that could otherwise be confusing.

After the first reflection of the P-wave in the concrete, the energy not transmitted out of the top surface of the concrete is again reflected toward the backwall, creating a multiple reflection. This process repeats itself until attenuation makes reflections undetectable. Because of the directive properties of the wedge, successive backwall reflections are displaced farther and farther from the transmitter. The RBM considers the increased path length traveled by reflected waves due to the transducer pitch-catch geometry. The TOAs of incoming waves can be estimated by the RBM only for simple geometries. Relative magnitudes of these waves can also be found from equations developed by Krautkramer and Krautkramer (1977) known as Knott's equations.

### **Approach**

Some basic concepts of stress-wave propagation have been presented in Appendix E. Some of these principles form the core of an RBM computer program. The RBM program can be applied to specimens of known geometry and velocity and somewhat more complex geometries once the simpler models are understood in the laboratory. A successful RBM program can be used to validate the interpretations from ANN or SSP techniques.

## **Simplified model**

If the size of the transmitter and receiver transducers are comparable, then a simplified model may be used with reservation (Krautkramer and Krautkramer 1977). For this model, the near field appears as a tube of the same area as the transmitting transducer; and once in the far field, the beam appears as a cone originating from the center of the transducer with the divergence angle calculated from Equation E5 in Appendix E. Currently, modeling routines treat the transmitter and receiver as emitting and receiving single rays with delays to calculate TOAs. Estimation of echo magnitude has not been integrated into the modeling program.

## **Model calibration**

The following experiment was performed as a preliminary test of the RBM program. Measurements of the TOA of multiple 2P-wave reflections from the backwall of a 2-in.-thick concrete slab were used to calibrate the RBM parameters, such as the transducer faceplate delay time. Delay times for the TOA through the transducer faceplate materials were adjusted so that the TOA of the calculated echoes from the RBM agreed with the TOA of the measured echoes (Figure 15).

## **Model testing**

Then, the RBM program was used to estimate the TOAs of backwall reflections for the 2P-, 2S-, and PS-waves for concrete slabs of 4- and 8-in. thickness. At the time of the test, the first model calculated multiple returns only for P-waves. The second model dealt with S-waves. As can be seen in Figure 16, the 4-in., 2P-echo was weak compared with the other echoes seen in the signal (this is verified by P and S magnitudes graphs in Malhotra and Carino (1991) for a P-wave with an angle of incidence of 50 deg). The model calculates only the TOA and not the amplitude of arrival. Then the S-wave velocity was set equal to 61 percent of the P-wave velocity, and the second routine was run to calculate the TOA of the PS- and 2S-wave. As seen in Figure 16, it would be difficult to label the mode type and the TOA without help from the RBM. The RBM estimated the 2P-wave TOA within 1  $\mu$ sec of the measurement TOA on the 8-in. slab (Figure 17).

# **Data Acquisition and Presentation of Results**

## **Data acquisition**

The next step was to improve the data acquisition and the presentation of the results. Previously, measurements had been initiated manually when the

transducers were properly positioned on the concrete surface with a viscous couplant between the transducers and the concrete. Now that measurements could be made while the transducers were on the move, it became necessary to initiate measurements automatically so that the separation distance between measurement positions was always constant and known. Also, since it was now possible to obtain hundreds of measurements in a short time over a short distance, it was desirable that the measurements be combined and presented graphically so that the results could be understood quickly.

### **Presentation of results**

A rotary encoder was installed on the rolling-pond frame that triggered (initiated) both the pulse generator, which excited the transmitting transducer, and the data acquisition unit. (See encoder above rolling pond at back and right side of Figure 18.) This position encoding system allows the user to set the desired separation distance of the ultrasonic readings. Data rates from 1 measurement/ft up to 12 measurements/in. are obtainable. A high-speed digital oscilloscope is used to store the sequence of incoming data signals issuing from the receiving transducer. Digitization resolution is 12 bits. A typical time-domain signal or A-scan is 1,000 digitized points sampled at 500,000 samples per second. The oscilloscope memory will store at least 100 of these signals (approximately 150,000 bytes) before the data are transferred to hard storage media or a host computer.

To present the data in a concise and explicable form, B-scans were used. B-scans are produced by normalizing reflected signals (highest peak is made equal to 1) and creating a matrix where each reflected signal is a column. (See Figure 19a and b.) The horizontal axis of this matrix represents the horizontal distance that the transducers move across the concrete surface during measurement. The vertical axis of this matrix represents the depth of reflections in the concrete. A linear color encoding of amplitude values is applied to this matrix to produce the B-scan image. Figure 19c and d illustrates this process. All operations can be implemented in real-time. To extend the color-map resolution, at the expense of losing some phase information, the absolute value of the data can be taken. The B-scan basically represents a cross-sectional view of the discontinuities in the concrete slab.

MATLAB software sold by The Mathworks was used to manipulate the data and generate the B-scan images. MATLAB is a high-performance numeric computation and visualization software package. This software was also used to perform the other signal-processing tasks described in this report. This scripted/command-based, compilable software is fast, easy to use, and widely accepted.

The high-resolution data collected with the UPE system can be stored on tape or disk. This provides a benchmark for comparing future test results from

the same site for the purpose of deterioration monitoring or assessing repair effectiveness.

Commercial off-the-shelf equipment now exists whereby the data-acquisition process and the B-scan display output can be integrated into one field unit. This system will allow continuous real-time B-scan display of the data during the scanning process. Future plans are to incorporate this new technology into the UPE system. This PC-based system should also allow other card-based system enhancements, such as electronics that permit the location to be determined by global position sensors, and remote data-transfer via modem.

A small battery-powered amplifier capable of 100X or 1000X gain is used to amplify the received ultrasonic signal. The amplifier is located close to the receiver to reduce electrical noise.

The results displayed graphically represent a significant improvement over the old method of analyzing individual A-scans.

## **Split-Spectrum Processing**

The information gained from NDE can be obscured by the presence of back-scattered echoes from discrete particles that make up the microstructure of a material. A digital signal-processing (DSP) technique called split-spectrum processing (SSP) was applied to the raw UPE signals to remove the effects of scattering of ultrasonic energy produced by the coarse and fine aggregate (particles) in the concrete. This multiple scattering from the various particles in the concrete is called material noise. Coarse-structured engineering materials all have the problem of creating material noise (Newhouse et al. 1982). The SSP technique is especially suited for materials such as concrete in which the particles are relatively large as compared with the flaws in the concrete. The SSP technique has been found to suppress material noise in metals, but it had not been tested on concrete until performed by Erickson (Wiberg 1993). Clutter (the indication of scattering from grain noise) can obscure the identification of the arrival of an echo from a material flaw. See Appendix G for a more detailed explanation of the SSP algorithm.

SSP was introduced in the late 1970's in an attempt to implement frequency agility techniques, originally used in radar for signal-to-noise ratio (SNR) improvement, for ultrasonic signals. When SSP is performed successfully, reflections from backwalls and flaws will remain in the signal record while reflections from grain or aggregate will be removed or reduced.

### **Digital signal processing**

Analog data must be digitized before they can be used by the computer. At that point, signals are in a form that the computer can process. The echo as

received from the receiver transducer of the UPE system is analog (a continuous signal), but by means of a computer data acquisition card, the analog signal is digitized (made discrete). DSP is the digital processing of signals. (See Appendix G for more detail on DSP.) Processing in this context means applying some mathematical algorithm to the original signal to change it in some way to be more intelligible. One very important goal of DSP is to enhance the SNR of an original signal. Another desirable function is to selectively extract a certain signal feature from the composite signal to determine the presence and amount of that feature.

### **Time invariant noise**

A problem with scattering from particles and echoes from flaws is that the energy is coherent for both cases; i.e., it does not vary with time. This makes it impossible to separate the noise from the signal by time averaging. If one obtains 10 UPE signals on an element of concrete over any period of time at one location, all 10 signals will be identical if the noise is coherent. If one averages all 10 identical signals, the average will be identical to each of the 10 signals. This means that time averaging does not enhance the SNR. WES researchers have found this to be the case for the UPE system.

### **Frequency-dependent noise**

Scattering from particles is frequency dependent while echoes from flaws are not. Because the particle size of the concrete is roughly equal to or less than the transmitted wavelengths and of variable shape and dimension, then the amplitude will vary for each frequency component of the reflected waves from a given particle. However, in general, the scattering from a flaw is not frequency dependent. Since the area of the flaw, delamination, or backwall will be large with respect to the wavelength, all frequency components will be reflected with equal amplitude having the same phase and polarity.

### **SSP implementation**

Based on the different interaction of the ultrasonic waves with the particles than with the flaws, the technique of SSP can be used to enhance the flaw echo with respect to the particle echoes, thereby increasing the SNR. By a process of spectral decomposition, digital processing, and then recombination of the signal, the SNR can be enhanced (Figure 20). Once the wide-band UPE signal is decomposed into a number of narrow-band signals, then there are many algorithms that can be applied to the split signals to remove material noise. The frequency characteristics determine the algorithm that is used, and in this case, the minimization algorithm was the algorithm selected. Enhancing the SNR is always the purpose of SSP. Also, a second algorithm, polarity thresholding, was used to improve detectability. A more detailed description of minimization

and polarity thresholding and its implementation is given in Appendix G. Figure 21 shows the improvement in the SNR when SSP is applied to a UPE measurement on a 2-in.-thick slab of concrete. The top plot is the unprocessed signal; the middle plot, the signal after applying minimization; and the bottom plot, the signal after polarity thresholding has been applied. WES researchers have not completed the optimizing of the processing protocol for concrete. However, SSP appears to have significant potential for improving a UPE system for concrete.

### **SSP of data**

SSP parameters were adjusted for detecting the longitudinal echoes of the 2-in. slab. Results are shown in Figure 21. A lower frequency and upper frequency must first be chosen for the data. The lower frequency was adjusted to 39 kHz, the upper frequency to 228 kHz, and the number of filters was set to 30 for these trials. The upper frequency had to be reduced by 5 kHz to detect predicted echoes in the 4- and 8-in. slabs. This frequency reduction agrees with presented theory. To create a more equalized (flat) response over the selected frequency range, the derivative of the raw signals was taken. The frequency domain transfer function of a derivative is a ramp function that increases with frequency. Results from SSP with minimization and polarity thresholding with minimization are shown in Figures 21, 22, and 23 for slabs of 2, 4, and 8 in.

## **Artificial Neural Networks**

### **Interpretation of signals**

Although a person can learn what type of signal feature is related to some physical condition in the concrete for general cases, it can be tedious for an individual to learn how to interpret complex signals. In some cases, the signal feature may be obscured by other parts of the signal. In those cases, DSP must be used to bring out the information hidden among other information and noise in the signal. Rather than train a person to recognize all the various twists and turns in the signal, which represent either voids, delaminations, reinforcing bars, backwalls, or other things, it would be more efficient to build a table that gives the presence and amount of each feature and use that table as input to train an ANN to recognize selected physical conditions, whether the concrete is high quality or deteriorated in some way.

Measurement criteria are standards and rules that can be used to make a judgment about the meaning of the signals. Before this research, very few rules had been discovered that related signal features to physical features in the concrete. Physical models were built containing simulated defects, and UPE measurements were made on those models to discover those relationships. In the medical field, a complex of symptoms indicating the existence of an

undesirable condition or quality is called a syndrome. For example, fever, headache, and vomiting may be symptoms of a viral infection. These same symptoms, however, might indicate polio (Miller 1967), as well as other diseases. The same is true for diagnosing the health of concrete. The type of defect (disease) or physical condition causes certain signal patterns (symptoms). It requires a collective set of signal features to characterize the condition of the concrete; i.e., it requires a syndrome of features.

### **Influence of concrete on stress waves**

From the theory presented on scattering and absorption in Appendix E, it can be seen that the input pulse shape applied to the concrete will be modified once it has propagated through the concrete some distance. Concrete acts as a low-pass mechanical filter and, generally, the shorter the original pulse length, the more the frequencies that make up the pulse are attenuated with propagated distance. Of course, the higher frequencies are attenuated more than the lower frequencies for a given pulse and a given concrete. This is true because of the frequency-dependent effects of scattering and absorption mentioned in Appendix E.

Many observations have been made of return signals from pulse-echo and through-transmission data on numerous laboratory concrete slabs, and they have demonstrated a variety of different return wavelets (short waves), although the input wavelet was the same in all cases. Building a store of expected wavelets for given slab thicknesses and concrete mixtures could be very useful in pulse-echo work. For example, various types of wavelets can be correlated with complex signal returns using the cross-correlation function to produce high-resolution polarized zero-phase representations of a reflected pulse (Robinson 1983). That is, since the composite pulse-echo signal is typically a summation of various echoes of different TOAs and mode types, then the correlation operation would bring out a recognizable signal at a certain TOA, if in fact it existed in the composite signal. Wave-shaping techniques such as the spiking filter can also be used to replace expected sinusoidal wavelets with shorter and sharper wavelets, therefore enhancing pulse resolution or separation or both. These techniques can help simplify raw data so that the mathematical model can improve the estimates of TOAs of various single and multiple reflections of various wave modes.

### **Elimination of expert**

Time and funding constraints of the project did not permit the full implementation of the ANN technique. Nevertheless, this technique remains an achievable objective in the future for replacing the human expert with operators who will be able to diagnose the concrete without a significant amount of training or experience. The details are given in Appendix H for how ANNs were trained to recognize different levels of microcracks in concrete specimens

from making UPE measurements. It was learned that Parseval's theorem could be applied to the raw UPE signals resulting in data that were directly related to the degree of microcracks. The raw data were reduced from 2,048 points to only 88 points. These 88 points then became the input for the ANN algorithm both for training and testing.

## **Expert System for UPE**

The process of making a UPE measurement is complex. The procedure includes setup of equipment, calibration, measurement, analysis, interpretation, and presentation of results. For that reason, it was desirable to develop some software that could give computer-aided guidance on all parts of the procedure. A KBES is ideally suited for that purpose. See Appendix I for more details on the description and uses of an Expert system.

As with the ANN system, the Expert system was not completed and implemented in this project. The application of this technology still remains an important area to be added to UPE measurements. Just as implementation of the ANN system would no longer require a person who is trained to interpret complex signals, so the Expert system would no longer require someone with training on how to conduct the measurement procedure.

Three different Expert software packages were purchased and studied. Level5 Object software sold by Information Builders, Inc., was chosen as the best choice. A preliminary program was written to guide the operator through the measurement procedure.

## **Results (Laboratory and Field)**

The system has been named the SUPERSCANNER, the acronym for Scanned Ultrasonic Pulse-Echo Results for Site-Characterization of Concrete Using Artificial Neural Networks and Expert Reasoning. The SUPERSCANNER is composed of a number of technological features, some of which are further along in their development than others. The following text describes some of the main features of the SUPERSCANNER and the stage of the development.

### **Laboratory experiment**

As mentioned earlier, a concrete test bed designed and constructed in the laboratory permitted the varied collection of 2-ft<sup>2</sup> physical models to be studied with the SUPERSCANNER. Because the length of the rolling pond is about 3 ft, the models to be tested required a departure slab and an approach slab so that the full length of the concrete models could be tested.

As one example, a 2-ft<sup>2</sup>, 6-in.-thick model was lowered into the space between the two slabs onto four screw jacks, and the top surface of the model was positioned vertically to be flush with the top surface of the test bed. The concrete model was sound and contained no simulated defects. Both the top and backwall surfaces were smooth. The joints between the access slabs and the model were sealed with soft rubber and silicone grease so that the rolling pond could pass over the joints without leakage. The SUPERSCANNER was pulled with a laboratory winch at a constant speed of about 0.2 ft/sec. The horizontal distance covered was about 15 in. Two hundred signals were plotted with each signal containing 1,000 points (Figure 24). Water was placed in the rolling pond to a depth of about 1 in., enough to immerse the granite faceplates of the two transducers. The plot shows the backwall echo from a 6-in. distance measurement on the departure slab and a 5-in. measurement near the center of the model slab; another 4-in. measurement on the approach slab can be seen clearly from the two-dimensional plot. The thickness of the departure and approach slab is 9 in. each. Note that the backwall echo from the 9-in.-thick model shows up clearly. No DSP was applied to the signals. This experiment represents one of the first measurements made with the UPE system while in motion. Previous measurements had all been stationary.

### Field tests

There are two events that alert the SUPERSCANNER operator of a flaw in a bridge deck. The first event is the disappearance of the backwall echoes. The second event is the appearance of echoes reflecting from the depth of the flaw. Figure 25, a B-scan collected from a newly constructed bridge, illustrates typical reflections received from the backwall surface of the deck. In Figure 26, reflections from a delamination on an overlaid deck are shown. Also, shown in these data is the presence of a surface-opening crack.

Figure 27 illustrates scans from several different slab thicknesses. The third panel in this series is from a deeply grooved (tined) 7-in.-thick deck. The scan shown in Figure 28 is from a steel-reinforced 11-in.-thick slab. The small vertical variation of the backwall echo is actually due to thickness variations in the slab thickness formed during finishing. This is a good example of the high-resolution and quality-control capabilities of the SUPERSCANNER. The scan shown in Figure 29 is from an 8-in.-thick concrete slab that was placed on a packed soil subgrade. The backwall reflection amplitude is lower and not as distinguishable because some of the transmitted energy is transmitted into the subgrade. This figure illustrates the capability of the SUPERSCANNER to operate on structures such as concrete pavements and runways.

The SUPERSCANNER and supporting equipment were transported to Omaha, NE, for a field demonstration at the annual PORT/UPE CPAR conference. About 70 Federal highway, State DOTs, and commercial representatives were in attendance. WES team members arrived several days before the conference to check out the equipment and perform preliminary

evaluation of the selected bridges. Local DOT personnel provided chain-drag expertise, information on bridge histories, and traffic control.

The first bridge that was examined was located in downtown Omaha. This bridge contained only a few small delaminations and extensive map cracking. A map-cracking pattern is typically characterized by numerous small surface cracks that join together three at a time with roughly a 120-deg angle between each crack. The severity and extent of the cracking prevented backwall echo detection. A severely microcracked surface reflects and attenuates the propagating ultrasonic energy, making backwall echo detection difficult or impossible.

The second bridge was an interstate overpass. The original bridge surface had been removed, and a concrete overlay with a tined surface had been put in place. The concrete overlay had severely delaminated from the original concrete deck. In most cases, both top and bottom deck surfaces could be accessed near the abutment, and thickness could be measured either from the side or through drain holes. On this particular bridge, the difficulty of bottom surface access prevented velocity and thickness calibration. Figure 26 shows a B-scan of this particular bridge. The delaminated sections are marked, as well as an internal crack. The small delamination on the left was missed by the chain-drag technique.

The water-coupling system worked well on both deck surfaces. Neither the tined nor microcracked surface caused significant water loss. These bridges presented an opportunity to test two new conditions: severe surface cracking and a concrete deck overlay. The system was successfully demonstrated to approximately 50 conference participants.

# 3 Development of Polymer-Injection System

---

## Literature Review

The detailed literature review served to determine the state of the art of the injection repair technique for bridge decks. In assembling the review, a number of domestic and foreign literature references, research findings, and performance data were collected. Literature was also collected on the extent and causes of bridge-deck deterioration. In addition to the literature review, a nationwide survey was conducted to obtain information on the current practices.

### Extent and causes of bridge-deck deterioration

Before a particular repair technique is employed, it is necessary to undertake a full examination of the state of a structure, to know the cause of the deterioration, and to ensure that the problem will not reappear quickly. Therefore, it has been proposed that overall bridge repair is best achieved by first examining the bridge-deck condition.

Of all bridge elements, the deck is the most susceptible to deterioration due to its flatness, exposure to salt, and abrasion. A vertical surface is generally more durable than a horizontal surface, alternate wetting and drying is more severe than total submersion, and alternating freezing and thawing is more damaging than constant freezing. It was also recognized that, in a marine environment, a concrete cover of at least 3 in. was necessary to protect the steel against corrosion. Yet bridge decks in many parts of the country are subjected to frequent applications of deicing salts on a horizontal surface, alternate wetting and drying, and freezing and thawing. The use of deicing salts increased dramatically in the 1960's and 1970's. Throughout the United States, 1.8 million tons of salt were used in 1961, 3.1 million tons in 1965, and more than 11 million tons in 1975 (Transportation Research Board (TRB) 1979). Bridge decks are also subjected to severe temperature gradients, fatigue, and high live-load stresses including impacts. They contain a congestion of

reinforcement, making the use of highly workable concrete essential. Because of finishing (often by hand) and bleeding, the concrete of the poorest quality in the deck is at the surface. Clearly, of all the elements in highway construction, bridge decks require special attention in all facets of design, material selection, and construction.

Bridge-deck deterioration is not a new phenomenon. There have always been decks that have cracked or developed defects because of environmental effects. In a survey conducted in 1967 (TRB 1970), in answer to the question, "What type of structure maintenance requires the greatest effort?" concrete bridge decks were ranked first. The perspective on bridge-deck deterioration has changed due to both the extent of the problem and the vast sums of money required to maintain the existing highway network. For many years, the causes of bridge-deck deterioration were not clearly identified. Exhaustive studies of the effects of stress, materials, and methods of construction were conducted (Sprinkel 1992, Heiman and Koerstz 1991, Kennedy 1977, Smoak 1978). Not only does corrosion destroy the smooth riding quality of the deck, it eventually reduces the structural integrity and safety of the deck slab and makes it is very difficult to make permanent repairs.

### **Characteristics of concrete**

Concrete is made from fine and coarse aggregates bound together by hydrated hydraulic cement. As such, it is the least homogeneous of the common construction materials. The most important property of the cement paste is its porosity. If the water-cement ratio ( $w/c$ ) of the concrete is higher than 0.4 by mass, the hydration products of the cement never completely fill the space originally occupied by the cement and the mixing water in the concrete mixture. The size and distribution of the pores within the paste influence many of the more important properties of the concrete including its strength and durability.

Concrete itself is generally isotropic, but the addition of reinforcement makes it anisotropic. Its low tensile strength means it is susceptible to cracking, and the width of these cracks must be controlled by reinforcement. An important characteristic of outdoor concrete is the typically high internal humidity and the constant exchange of moisture between the concrete and its environment, which results in relatively large volume changes. Where the concrete is restrained, the volume changes resulting from changes in humidity or temperature can result in cracking of the component.

The durability of concrete is determined by its quality and the exposure conditions. In general, concrete quality is primarily a function of the  $w/c$ . As the  $w/c$  (and consequently the porosity) decreases, durability increases, provided the concrete has been made from sound materials and has been properly proportioned, consolidated, and cured. Air entrainment (Hover 1993) is required for resistance to freezing and thawing under wet conditions. The

biggest problem in the durability of concrete highway structures in recent years has been the corrosion of embedded reinforcing steel, which results from chloride ions penetrating the concrete.

### **Bridge-deck deterioration**

Several reports that address bridge-deck deterioration have shown an apparent similarity in the types of defects noted. "The Cooperative Bridge Deck Study," Report 5 (Portland Cement Association 1969), provides a good overview of the defects on 813 bridges summarized from surveys in eight states. From this survey, three conditions of bridge-deck deterioration are commonly identified: cracking (76 percent), scaling (34 percent), and spalling (12 percent). In addition, two performance criteria were identified from the surveys that need to be satisfied: adequate skid resistance and lack of wear, especially differential wear in the wheel tracks.

**Cracking.** The significance of cracks in concrete is dependent on their origin and whether the length and width increase with time. There are several possible causes of cracking in concrete structures. The most common causes and characteristics of these cracks can be summarized as follows (Babaei and Hawkins 1987):

- a. Plastic-shrinkage cracks result from rapid drying of the concrete in its plastic state. The cracks are usually wide but shallow and often in a well-defined pattern or spaced at regular intervals.
- b. Drying shrinkage cracks result from the drying of restrained concrete after it has hardened. These are usually finer and deeper cracks than plastic-shrinkage cracks and have a random orientation.
- c. Settlement cracks may be of any orientation and width and range from fine cracks above the reinforcement resulting from formwork settlement to wide cracks in supporting members caused by foundation settlement.
- d. Structural cracks, except for those controlled by the provision of reinforcement, result from differences between assumed and actual stress intensity. The width varies but the orientation is often well defined. Examples are diagonal cracks in the acute corners of severely skewed decks and longitudinal cracks over internal voids in thick slab decks.
- e. Map cracking (a closely spaced network of cracks) usually results from chemical reactions between the mineral aggregates and the hydroxide ion in the pore fluid. The number and the width of the cracks usually increase with time. A number of reactions can cause map cracking. The reactions between the alkalis from the cement, or from external

sources with constituents of some aggregates (producing alkali-silica or alkali-carbonate rock reaction) are the most widespread. Both types of reaction result in serious damage to the concrete by causing abnormal expansion, cracking, and loss of strength.

- f. Corrosion-induced cracks (resulting from the corrosion of embedded reinforcement) are usually associated with shallow cover and are located directly above the reinforcement. The cracks terminate at the reinforcement and rust stains may be associated with them. The width of the cracks increases with time as the corrosion continues.

**Scaling.** Scaling is the flaking away of the surface mortar of the concrete. As the scaling progresses, coarse aggregate is exposed and eventually loosened. Scaling results from the repeated freezing of concrete that is not frost resistant and that is critically saturated with water and is aggravated by the presence of deicing salts. However, it is a surface phenomenon and can be prevented by the use of a low w/c, air-entrained concrete.

When concrete of w/c greater than 0.4 by mass dries, voids, called capillary cavities, are left by the evaporating water. When the water in a water-saturated cavity is frozen, either the volume must expand by 9 percent (TRB 1970), or the excess water forced out. In any system of voids, moisture tends to move from larger voids to smaller ones. Since the entrained air voids are far larger than the capillary voids, they remain essentially free of moisture. They are available as points of pressure relief. After thawing, the moisture is forced from the entrained-air voids to the capillary cavities by the compression of the air in the entrained-air voids. If enough entrained air voids are present, disruptive hydraulic pressures will not develop. A low w/c paste will have smaller and fewer potentially vulnerable capillary cavities and will therefore be more resistant to frost action. Air entrainment is a well-proven method of avoiding freezing damage in cement paste. However, in the presence of deicing salts, air entrainment does not always give complete protection against scaling. The salt increases the degree of saturation of the concrete because salt melts the ice and makes water available to be absorbed.

**Wear and polishing.** Excessive wear may be present on concrete surfaces exposed to traffic abrasion and is usually concentrated in the wheel tracks. Serious rutting may be present where studded tires are permitted. Wear can sometimes be difficult to distinguish from grinding (used at the time of construction to achieve an acceptable surface tolerance) and light scaling. Curb areas may be subject to the scraping action of snow plows.

Except in isolated instances, notably urban freeways, wear on bridge decks has not caused serious deterioration, though it is a factor in determining the service life of a deck. Differential wear in the wheel tracks, usually where studded tires are permitted, causes water to pond in these locations, accelerating deterioration of the concrete and also decreasing the safety of the highway.

Even in the absence of studded tires, wear can cause a safety hazard because of aggregate polishing. Few states currently specify a minimum coefficient of friction (TRB 1970, 1979, 1983). As the techniques for the measurement of skid resistance are further developed, skid resistance is likely to play an increasingly important role in determining the serviceability of bridge decks.

**Delamination and spalling.** In bridge decks, it is common to experience horizontal cracks (delaminations) above corroding reinforcing bars, thus producing a delaminated area.

The mechanics of delamination and spalling begin when chloride ions penetrate the concrete to the level of the reinforcing steel, either slowly permeating through the concrete or penetrating more quickly through cracks. Cracks are formed because the iron oxides occupy a significantly larger volume, variously reported at 2.2 to approximately 13 times the volume of the original metal (TRB 1970, 1979, 1983; Portland Cement Association 1965, 1966, 1967, 1968, 1969, 1970; Babaei and Hawkins 1987; Al-Mandil, Baluch, and Azad 1990). Considerable pressure is exerted by the corrosion process when this expansion is prevented, and pressures as high as 4,700 psi have been reported (TRB 1970). The amount of corrosion required to cause a crack is very small. A corrosion pit depth of 0.001 in. is sufficient to crack a 0.875-in.-thick concrete cover (TRB 1970). If the corroding area of the bar is sufficiently large, a delaminated area or a trough or conical spall occurs.

In order to learn more about the fracture planes that existed below the top surface of the concrete in the areas of shallow steel, a study of a series of pullouts was made (Crumpton et al. 1969). The pullout procedure involved first locating the lateral extent of the hollow area (delamination) by tapping and then sawing a rectangular slab within the boundary of the hollow area. A flat steel bar was next glued to the concrete surface with epoxy resin. Through the use of eye bolts, turnbuckles, and sawhorses, the concrete slab above the fracture plane was lifted from the surface of the deck. The pullout studies verified what other observations derived from previous examination of cores, that the fracture planes were not horizontal but actually undulated. The undulations frequently followed the theoretical pattern of the plane of weakness described by Missouri. A second undulating or curving fracture plane was also sometimes observed over a reinforcing bar and elongated in the same direction as the bar. Similar sets of planes were observed in a test slab in Kansas. In fact, more than one set of fracture planes was often observed in the pullouts and in cores from the Blue Rapids Bridge (Crumpton et al. 1969). It was noted from the pullout studies and from examinations of many cores that the fracture plane sometimes dropped below the transverse steel to the longitudinal steel and followed it to the next transverse bar where the plane ascended to the top of the transverse bar. Chert coarse aggregate particles also were noted to influence the path of the fracture by causing it to move above or below the reinforcing steel plane. With increasing time, those small hollow areas became larger and sometimes grew until two or more merged into one large hollow area. Examination of the surfaces of the fracture plane showed that water and

dirt had reached the level of the fracture plane and the transverse steel through the pop-out created by the chert aggregate particle. The surfaces of the fracture plane near the chert pop-out were coated with dirt carried into the plane by surface water entering through the hole created by the pop-out. Corrosion products from the reinforcing steel were found in the fracture plane of all the pullouts and in many of the cores. Cores obtained from over reinforcing bars 2 in. or more deep in the sound concrete areas of deck, however, did not show any corrosion of the bars. The corrosion products in the fresh pullouts exhibited a variety of colors. Colors from green and olive-gray usually changed to dark brown or black after being exposed to the air for a short time.

Once bridge decks delaminate, the repeated action of vehicular loading and the formation of ice in the delaminated area results in the familiar spall or pothole unless remedial action is taken. Substantial thickness of concrete may be involved and, once initiated, it is difficult to halt the corrosion process and permanently repair the damage. An extensive literature review is given in Appendix A.

### **Analysis of survey results**

A total of 377 survey questionnaires were sent to 50 DOTs, miscellaneous contractors, U.S. Army Corps of Engineers (USACE) offices, and polymer material suppliers. The survey questionnaires included three different parts, i.e., polymer/epoxy injection, flood coating/impregnation, and other repair methods. The distribution of the 377 questionnaires were as follows: 50 to DOTs, 69 to USACE offices, 58 to material suppliers, and 200 to construction contractors. Appendix B contains a survey questionnaire. The research team received 46 completed questionnaires for a 12.2-percent response rate. The breakdown of the returned questionnaires is as follows: 23 DOTs, 46.0 percent; 10 USACE offices, 14.5 percent; 5 material suppliers, 8.6 percent; and 8 contractors, 4.0 percent.

#### **Response to Part 1.**

- a.* Of the 46 returns, 34.8 percent responded that they had used polymer/epoxy injection methods before. In particular, the Federal Highway Administration (FHWA) said that Iowa DOT had conducted similar surveys before and suggested that the research team should duplicate their responses.
- b.* How to select bridge decks to be repaired by the injection method was one of the research subobjectives. Most of the respondents did not have any criteria. However, the following criteria were listed by some of the respondents: (1) have a sound deck, surface cracks only; (2) have delaminations and only limited spalling; and (3) take chloride tests per engineer specifications. Based on the survey, a broad inference could be made that when bridge decks experience hairline cracks in

30 percent of the delamination area, the injection method should be applied before deck conditions worsen and a more expensive repair method is required.

- c. Chain drag and hammer is the predominant (94.4-percent) delamination detecting method. Using radar and infrared to detect delaminations was listed by 22.2 percent of the respondents.
- d. It is very important to choose an appropriate particular polymer material to make injection repairs. The following materials were listed by respondents: Sika, Webac, HMWM, 3M, Reco, STO, Fosroc, Deneef, SM, Polycarb, Concrevice, T70-P, and T70MX30.
- e. In order to estimate the actual field performance of a polymer/epoxy, the following laboratory tests were suggested by the respondents in the order of importance: (1) tensile and/or compressive strength test; (2) moisture absorption test; (3) slab and beam test; (4) freezing-and-thawing test; (5) the influence of internal moisture; (6) image analysis; and (7) petrographic analysis. In addition, crack movement and elongation of material were listed by some respondents. They suggested that if the structure moves, use urethane, and if the structure is located indoors at a close range of thermal conditions, use epoxy. Otherwise, the epoxy will hold, but the concrete adjacent to the repair will shear. Epoxies claiming elongation movement capabilities still cannot move enough to accommodate shear.
- f. Single drill/solid bit drilling device was used by 46.7 percent of the respondents, single drill/hollow bit with vacuum attachment by 40.0 percent, and multiple drill or gang drill system by 6.7 percent. In the survey, 26.6 percent of the respondents preferred to use single drill/solid bit, 60 percent prefer to use single drill/hollow bit with vacuum attachment, and only 13.3 percent would like the idea of a multiple drill or gang drill system.
- g. To find the best field application procedure for the polymer-injection repair was one of the subobjectives in this project. Factors that influenced decisions are summarized below.
  - (1) *Selection of a particular polymer material.* Generally, there are no selection criteria available. The current practice is based on the material supplier's manual and past experience. Some respondents mentioned the following factors were considered when choosing a particular material: variable cure time, low viscosity, and contractor's choice. The influencing factors listed are: performance flow and adhesion characteristics, price, tolerance to moisture, and name brand plus good relationship with the material suppliers.

- (2) *Pattern of the injection holes.* The current practice on the location of the injection holes can be summarized as 6 to 12 in. on center. Some respondents mentioned that the spacing should vary with depth. However, the influencing factors are viscosity of the material and grout flow distance. The injected material should fill the delaminated area.
- (3) *Size of the injection holes.* The current practice on the diameter of the injection hole is 1/4 to 5/8 in. The drilling equipment was listed as the influencing factor.
- (4) *Method of cleaning the injection holes.* The current cleaning methods are air (35.7 percent), water (28.6 percent), and vacuum (28.6 percent). Most of the respondents said the cleaning method should be compatible with the material used and should not stop up cracks.
- (5) *Injection pressure.* The actual pressure used varied from 0 psi to as high as 3,500 psi according to the survey. Some respondents did express concerns about the possibility of popping the spall. The following influencing factors were listed when choosing injection pressure: flowability of material, crack width, temperature, and viscosity and pot life of the material.
- (6) *Injection equipment.* Respondents said any American pump that goes up to 200 psi would work fine. The main influencing factor listed is the price of the equipment.

#### **Response to Part 2.**

- a. Of the 46 returns, 32.6 percent had used polymer flood-coating/impregnation rehabilitation before. The reasons they decided to apply this repair method were as follows: preventive method to extend the life of bridge deck (60.0 percent); experiment on an advanced material (Webac 2150, Pronto 19, Polycarb epoxy, and Daval) (40.0 percent); confidence in flood coating based on past experiences (40.0 percent); deck too severely damaged to be injected (40.0 percent); and rejection of overlays as solution (6.7 percent). Other reasons mentioned in the survey were contract requirement, speed required for repair, cracks in deck but no delamination, and seal cracks less than 0.33 mm.
- b. In the case of flood coating, 60.0 percent of the respondents said that they tested the moisture content in the bridge deck concrete before applying flood coating or would not apply sealant if moisture was present or expected during procedures.

- c. In order to improve skid resistance of the flood coating, the following measures were taken based on the survey: (1) used silica (30.0 percent), quartz sand (20.0 percent), or sand (20.0 percent) as the aggregate; (2) the aggregate should be applied at about 1 to 3 lb/ft<sup>2</sup>; and (3) the skid resistance number should be tested.

**Response to Part 3.**

- a. Of the 46 respondents, 65.2 percent had not used polymer-injection or flood-coating repair methods. Some of the major reasons are listed below:
  - (1) Unfamiliar with injection or coating method.
  - (2) Satisfied with the current repair system.
  - (3) Delaminations reappear.
  - (4) Afraid of causing more damage if too much pressure used.
  - (5) Funds shortage.
  - (6) High cost per square foot as compared to thin overlay.
  - (7) Not adequate information on life span of decks after the treatment.
  - (8) Polymer-injection effectiveness is unproved technology.
  - (9) Difficult to handle.
  - (10) Sealing of the top surface tends to trap moisture.
- b. The average anticipated life of a concrete bridge deck is about 20 years (old design) to 50 years (new design), and the number of bridge decks maintained every year by the survey respondents varied from 3 or 5 to as high as more than 5,000.
- c. As far as any conceptual details, special provisions, or reports that may be helpful in developing design guidelines for polymer-injection or flood-coating methods, most respondents suggested following the material supplier's specifications. The problems investigated in this project were adherence of the polymers to the concrete in less than desirable conditions, cracks reopening, and deep penetration of cracks.

## Materials and Equipment Specifications

This section contains the material and equipment specifications used in this project. There were three material suppliers and three equipment suppliers involved in this project. The material suppliers were Sika Corporation, Transpo Industries, Inc., and Unitex. The equipment suppliers were E-Z Drill, Inc., Liquid Control Corp., and U.S. Filter. Brief descriptions of the specifications for their materials and equipments follow.

### Material specifications

There were three different materials for three different applications: (a) injection (subsurface delamination repair), (b) Category I (sealer healer), and (c) Category II (surface coating with new wearing surface). Each of the material suppliers provided the materials for the applications. All the materials were two-component products. Both the components needed to be mixed before application.

#### Sika Corporation:

- a. *Injection:* The resin used was Sikadur 52, Sikadur Injection Gel SC-020; however, Sika used Sikadur 35 Hi Mod Lv in the first laboratory test and in the delamination injections in Michigan and Mississippi.

#### (1) *Materials:*

- (a) Component A shall be a modified epoxy resin of the epichlorohydrin bisphenol A type containing suitable viscosity control agents. It shall not contain butyl glycidyl ether.
- (b) Component B shall be primarily an aliphatic diamine containing suitable viscosity control agents and accelerators.
- (c) The ratio of Component A: Component B shall be 2:1 by volume.

#### (2) *Performance criteria.*

- (a) Properties of the mixed epoxy resin adhesive used for the pressure injection grouting.
  - Pot life: 20 to 30 min.
  - Tack-free time to touch (3 to 5 mils): 5 to 7 hr.

- Initial viscosity (Brookfield viscometer, spindle #2; speed 100): 150 to 200 cps.
  - Color: clear, amber.
- (b) Properties of the cured epoxy resin adhesive used for the pressure injection grouting.
- Compressive properties (ASTM D 695) at 28 days.
    - Compressive strength: 10,200 psi (minimum)
    - Modulus of elasticity: 300,000 psi (minimum)
  - Tensile properties (ASTM D 638) at 14 days.
    - Tensile strength: 5,300 psi (minimum)
    - Elongation at break: 2 to 3.5 percent
    - Modulus of elasticity: 170,000 psi (minimum)
  - Flexural properties (ASTM D 790) at 14 days.
    - Flexural strength (modulus of rupture): 4,600 psi (minimum)
    - Tangent modulus of elasticity in bending: 320,000 psi (minimum)
  - Shear strength (ASTM D 732) at 14 days: 4,600 psi (minimum).
  - Total water absorption (ASTM D 570) at 7 days: 1.5 percent maximum. (2-hr boil).
  - Bond strength (ASTM C 882) hardened concrete to hardened concrete.
    - 2 day (dry cure): 2,500 psi (minimum)
    - 14 day (moist cure): 2,000 psi (minimum)
  - Deflection temperature (ASTM D 648) at 14 days: 104 °F (minimum) (fiber stress loading = 264 psi).
  - Vicat softening temperature (ASTM D 1525) at 14 days: 110 °F (minimum).
  - Effective shrinkage (ASTM C 883): passes test (minimum).
  - The epoxy resin adhesive shall be approved by the U.S. Department of Agriculture.

*b. Category I:* The resin used was Sikadur 55 SLV Healer/Sealer Materials:

- (1) *Materials:*
  - (a) The ratio of Component A: Component B shall be 2.5:1, by volume.
  - (b) Aggregate for broadcasting shall be standard mason or concrete sand that is saturated-surface dried, as approved by the engineer.
- (2) Properties of the mixed epoxy resin.
  - (a) Pot life: approximately 25 min.
  - (b) Color; clear, amber.
- (3) Properties of the cured epoxy resin:
  - (a) Compressive strength (ASTM D 695).
    - 1 day, 5,000 psi (minimum)
    - 3 days, 12,000 psi (minimum)
    - 28 days, 15,000 psi (minimum)
  - (b) Tensile properties (ASTM D 638) at 7 days.
    - Tensile strength: 7,000 psi (minimum)
    - Elongation at break: 2.3 percent
  - (c) Flexural properties (ASTM D 790) at 7 days.
    - Flexural strength 9,000 psi (minimum)
    - Tangent modulus of elasticity: 480,000 psi (minimum)
  - (d) Bond strength (ASTM C 882 modified) hardened concrete to hardened concrete.
    - 2 day (moist cure): 1,400 psi (minimum)
    - 14 day (moist cure): 2,700 psi (minimum)
  - (e) Deflection temperature (ASTM D 648) at 7 days: 120 °F (minimum) (fiber stress loading = 264 psi).
  - (f) Total water absorption (ASTM D 570) at 7 days = 0.61 percent.
  - (g) The material shall not produce a vapor barrier.
  - (h) The epoxy resin shall conform to ASTM C 881 and American Association of State Highway and Transportation Officials (AASHTO) T235 (AASHTO 1990a).

c. *Category II*: The resin used was Sikadur 22, Broadcast SC-032.

(1) *Materials*:

- (a) Component A shall be a modified epoxy resin of the epichlorohydrin bisphenol A type containing suitable viscosity control agents. It shall not contain butyl glycidyl ether.
- (b) Component B shall be a blend of aliphatic amines containing suitable viscosity control agents and accelerators.
- (c) The ratio of Component A: Component B shall be 1:1 by volume.
- (d) Aggregate for the epoxy resin broadcast shall be an oven-dried, 20 to 40 graded sand approved by the engineer.

(2) *Performance criteria*:

(a) Properties of the mixed epoxy resin:

- Pot Life: 25 to 35 min
- Tack-free time to touch (4 to 7 mil): 3.5 to 4.5 hr
- Initial viscosity (Brookfield viscometer, spindle #3; speed 100): 3,100 to 3,900 cps
- Color: clear, amber

(b) Properties of the cured epoxy resin:

- Compressive strength (ASTM D 695) at 28 days.
  - Compressive strength: 6,500 psi (minimum)
  - Modulus of elasticity:  $1.5 \times 10^5$  psi (maximum)
- Tensile properties (ASTM D 638) at 14 days.
  - Tensile strength: 6,000 psi (minimum)
  - Elongation at break: 20.0 percent (minimum)
  - Modulus of elasticity:  $1.1 \times 10^5$  psi (maximum)
- Flexural properties (ASTM D 790) at 14 days.
  - Flexural strength (modulus of rupture): 6,000 psi (minimum)
  - Tangent modulus of elasticity in bending:  $3.2 \times 10^5$  psi (minimum)

- Shear strength (ASTM D 732) at 14 days: 5,000 psi (minimum).
- Total water absorption (ASTM D 570) at 7 days: 1.5 percent maximum (2-hr boil).
- Bond strength (ASTM C 882 modified) hardened concrete to hardened concrete.
  - 2 day (dry cure): 1,000 psi (minimum)
  - 14 day (moist cure): 1,500 psi (minimum)
- Deflection temperature (ASTM D 648) at 14 days: 100 °F (minimum) (fiber stress loading = 66 psi).
- The epoxy resin adhesive binder shall conform to ASTM C 881 and AASHTO T235 (AASHTO 1990a).
- The epoxy resin adhesive binder shall be approved by the U.S. Department of Agriculture.

**Transpo Industries, Inc.:**

a. *Injection:* The resin used was TRANSPO T-70P.

Physical Properties Technical Data Sheet

Viscosity	60 to 100 cps	ASTM D 1824
Density	8.43 lb/gal	ASTM D 1425
Tack free time	6 hr (max)	Cal Test 551
Gel time	30 min	ASTM D 2471
Percent elongation	20 percent (min)	ASTM D 638
Tensile strength	10 psi (min)	ASTM D 638
Compressive strength	6,000 psi (min)	ASTM C 881
Flash point	> 190 °F	ASTM D 93

b. *Category I:* The resin used was Transpo T-70.

Physical Properties Technical Data Sheet

Viscosity	14 to 15 cps	ASTM D 1824
Density	8.68 lb/gal	ASTM D 1425
Tack free time	6 hr (max)	Cal Test 551
Gel time	30 to 40 min 2/4 co/chp	ASTM D 2471
Percent volatile	24 to 25 percent	ASTM D 2369
Percent elongation	3 to 5 percent	ASTM D 638
Tensile strength	1,600 psi (min)	ASTM D 638
Compressive strength	1 hr = 2,000 psi 24 hr = 8,250 psi	ASTM C 39



(2) *Strength and properties.*

• Viscosity	175 cps	ASTM D 2393
• Gel time	45 min	ASTM C 881
• Bond strength (2 day cure)	2,413 psi	ASTM C 882
• Bond strength (14 day cure)	3,612 psi	ASTM C 882
• Absorption	0.85 percent	ASTM D 570
• Heat deflection temperature	50 °C	ASTM D 648
• Linear coefficient of shrinkage	0.0021	ASTM D 2566
• Compressive strength	10,685 psi	ASTM D 695
• Compressive modulus	210,000 psi	ASTM D 695
• Shear strength	9,040 psi	ASTM D 732
• Tensile strength	7,010 psi	ASTM D 638
• Flexural strength	9,664 psi	ASTM D 790
• Shrinkage	Complies	ASTM C 883
• Thermal compatibility	Complies	ASTM C 884
• Percent elongation at break	2.96 percent	ASTM D 638
• Filler content	0.0 percent	ASTM C 881

b. *Category I.* The resin used was Pro-Seal HS.

(1) *Material.* A two-component epoxy-based sealing material designed both for the protection of new concrete and for the preservation of partially deteriorated concrete to extend its service life. Pro-Seal HS penetrates into the concrete pore structure to form a surface sealing layer that will effectively impede moisture incursion and corrosive chemical penetration.

- Easy mix, convenient volume ratio: mix 1 part A to 1 part B.
- Low viscosity for high penetration.
- Cured coating provides reduced absorption and reduced chloride-ion intrusion into concrete.
- Sealed surfaces are easier to clean and exhibit reduced dusting.
- The application of Pro-Seal HS is a simple process not requiring any specialized pressure-injection equipment. The simplicity of application not only reduces equipment cost, but also reduces the need for specialized or trained labor.
- The formulation of Pro-Seal HS includes a moisture insensitive, chemically curing epoxy system that enables it to be used effectively on either dry or damp surfaces. Dry surfaces are recommended for better crack protection. Moreover, use of Pro-Seal HS on concrete structures reduces or eliminates the chloride permeability of that structure, thus protecting it from further deterioration.
- Low surface tension and excellent adhesion properties of Pro-Seal healer/sealer allow it to penetrate deeply and bind to the inner walls of cracks, in many cases restoring the original integrity of the concrete.

(2) *Physical properties.*

	<u>Part A</u>	<u>Part B</u>	<u>Mixed System</u>
Weight per gallon:	8.7 lb	7.7 lb	8.2 lb
Viscosity	< 50 cps	< 50 cps	< 50 cps
Specific gravity	1.05	0.93	0.97

c. *Category II:* The resin used was Pro-Poxy Type III DOT.

(1) **Material:** A solvent-free, moisture-insensitive, low-modulus, two-component epoxy binder meeting ASTM C 881 Type III classes Band C grade 1.

- Moisture insensitive before and after cure.
- Easy self-leveling low viscosity.
- Easy to mix 1:1 ratio between components.
- Excellent bond strength.
- Low modulus provides shock absorbing qualities.

(2) *Strength and properties.*

Viscosity	1,500 cps	ASTM C 881
Gel time	30 min	ASTM C 881
Bond strength (14 day cure)	1,600 psi	ASTM C 882
Absorption	0.84 percent	ASTM D 570
Compressive modulus	100,000 psi	ASTM D 695
Tensile strength	2,500 psi	ASTM D 638
Shrinkage	Complies	ASTM C 883
Thermal compatibility	Complies	ASTM C 884

## Equipment specifications

a. **E-Z Drill.**

- (1) Drilling equipment for drilling injection holes.
  - Automatic drill system with pneumatic feed.
  - Mounted on a wheeled cart for easy mobility.
  - Guided drill system to assure identical holes.
  - Regulated feed pressure to reduce spalling.
  - Hole depth gauge.
- (2) Drill system includes:
  - Electric rotary impact drill (Hilti TE-5, 650 W, 115 V, 6 amps, freq. 50 to 60 Hz, hammering speed under load: 0 to 3,800 bpm).
  - Optional Hilti TE-15 dust removal system for vacuuming used in conjunction with a 6-gal/2.0 HP shop vac.
  - Air compressor for regulated feed and retract (3/4 HP, 115 V, 11.4 amps, 2.10 cfm @ 100 psi).

- b. **Liquid Control Corp.** Equipment for injection of material. Liquid control equipment and accessories have the following specifications:
- (1) Hi/low pressure transducer control box that will sense excessive hydraulic back pressure and kick down the injection machine pressure to a preset and adjustable safe level. The mixed material will be displaced through a pressure gauge and transducer connection. The transducer will read actual line pressure and feed back to a separate control panel housing two independent pressure regulators. This second control panel will require electric service (120 V/1/60) for the transducer. The in-line transducer will sense a rise in line pressure beyond what is desired and kick down to the second air regulator set at a much lower machine drive pressure.
  - (2) Posiratio<sup>®</sup> mini-crack injection machine. The machine will mix and inject two-component, reactive resins in a 1:1 or 2:1 volumetric mixture ratio. The equipment will be pneumatic with 0.3 to 2 SCFM service requirements @ 90 psi. The epoxy resin and hardener or methacrylate base and hardener will be gravity fed from 2 gal, translucent, polyethylene tanks to two individual metering pumps. Metering pumps will be of the Posiload<sup>®</sup> (vacuum assist reload) design, mild steel/hard-chromed, incorporating a 25-mm piston and metering tube in the resin pump along with a 17.67-mm piston and metering tube in the hardener pump for 2:1 ratio; 1:1 ratio will require a 20-mm piston and metering tube for both the base and hardener. The resin tank to be labeled A with red coding on wetted components (hose, pump, and non-drip valves). The hardener tank to be labeled B with yellow coding on wetted components. Hose length from the machine metering tube check valves to the dispense head will be 15 ft. Machine control panel will include an air regulator and gauge for material flow control and an on/off selector switch. The machine drive will incorporate a 2.5-in.-diameter air cylinder and will maintain a power factor of 4.30:1 for the 2:1 unit and 5:1 for the 1:1 unit. Machine weight will be 55 lb, and machine dimensions will be 12 in. wide by 27 in. long by 21 in. high.
  - (3) Twin dispense head assembly. The assembly includes an on/off lever handle, twin 300-psi fluid pressure gauges, quick disconnect Twin dispense nose, Posimixer disposable mixer shroud (part # 94/0880-C/99), shroud adapter (part # 94/0882-A/98), 1/4 x 24 disposable Posimixer (part # 60/0204/50), pressure transducer, hose connector fitting (part # 64/0720/96), pressure rated injection hose (part # 61/0068/89), manifold T port connector (part # 84/0500/96), and port shut-off relief valve (part # 94/0500/96). Drilled ports with a tapered base (part

#84/0508-1/11) will be required to inject the epoxy into the bridge decks along with special plastic T port connectors (part #84/0500/96). Hole size requirement for drilled ports will be 1/2-in. diameter. The T connection will come off a 1/4-in. whip tube (1,000 psi) (part # 61/0068/89) rating and connect via taper fit to the drilled port. A second opening in the T fitting connection will provide a means of bleed off and pressure relief with the use of a shutoff ball valve (part # 94/0500/96).

c. **U.S. Filter:** Equipment for Shot Blasting. Nelco GPX-16-65 DC Rider.

(1) **Features.**

- Self-contained on-board dust collector system.
- Optional 12-in. cut for line removal available upon request.
- Incorporated Nelco's patented paddle wheel design.
- Hydraulically controlled seal adjustment.
- One-man operation.
- Equipped with a centrifugal clutch.

(2) **Specifications.**

• **Machine:**

Blast pattern	16 in.
Blast media	Steel Shot Sz 230-550
Shot hopper capacity	200#
Engine	Wisconsin 65 HP
Fuel	Gasoline (unleaded) Propane (liquid)
Fuel capacity	11.5 gal (gasoline) 43.5 l (propane)
Drive	Hydrostatic transmission
Travel speed	0 to 200 ft/min
Shot Valve	Hydraulic
Seal Lift System	Hydraulic
Ignition System	12 Volt DC
Length	104 in.
Width	62 in.
Height	66 in.
Weight	3000#
Shipping Weight(pallet)	3300#
Shipping Weight(crate)	3800#
<b>Dust Collector:</b>	
CFM	2600
Dust Capacity	6.5 ft <sup>3</sup>
Cartridges	6

# Laboratory Evaluation of Polymer Materials (Phase I)

## Introduction

One of the tasks of this project was to evaluate the short- and long-term performance of injected polymer materials in bridge-deck delaminations. The purpose of polymers in the deck delaminations is to bond the delaminations so that the bridge deck behaves as a single unit. There are plenty of bonding material suppliers available in the market for this purpose. The performance of these materials is different in varying situations. This project was designed to study the performance of some of these polymer materials in a worst-case situation. In order to evaluate this performance, tests were conducted by the research team. These tests included compression, tensile, flexural, freezing and thawing, and ultraviolet (UV) exposure tests. For the first four of these tests, the sandwich-panel concept was used to prepare the actual specimens in the laboratory. For the UV-exposure test, a different method was used to make the specimens. The preparation of these test is outlined in this chapter. All tests were performed according to ASTM specifications except for the direct-tensile and UV-exposure tests. A new testing technique was developed for both of these.

## Research plan

The adhesive injection repair technique is an effective repair method for deteriorated bridge decks. However, there are many different adhesive materials available on the market that can be used for the same purpose. Some of the material does not bond properly in the presence of moisture while other materials do not perform well in the presence of debris. The following are identified as dictating parameters for a good bonding performance of the material:

- a.* The condition of the crack surface where material is applied. Here, the condition of the crack surface refers to whether the surface is smooth or it has peaks and valleys. As the injected surface is generated by concrete cracks, it is likely to have peaks and valleys.
- b.* The presence of debris in the crack makes some material repel from the crack surface. Initially, the material is bonded to the debris and eventually becomes detached from the surface.
- c.* The presence of moisture has a negative effect on bonding capacity for some adhesive materials. The moisture on the crack surface prevents material from bonding to the surface. Polymer materials with moisture-adsorption capacity perform best under this circumstance.

- d. The viscosity of the material is important in this type of repair technique. The viscosity of material and the crack width are interrelated parameters. If the material viscosity is very high, it does not flow through small cracks. On the other hand, if viscosity is low, most of the material is absorbed into the concrete mass rather than staying in the crack.

In order to select a material for this type of repair technique, it is essential to evaluate the material in the laboratory before its application in the field. A protocol was designed to evaluate these materials in the laboratory. This laboratory evaluation was designed for a worst-case scenario. Before the laboratory specimens were designed, a preliminary investigation was performed to determine the constituents of debris found in the delaminated fracture surface by examination of a delaminated concrete deck. The debris in the delaminations was brushed out carefully to perform a sieve analysis. Table 1 gives the results of the sieve analysis of the delaminated fracture surface. Further, petrographic examination using polarized light microscopy (PLM), image analysis, and X-ray diffraction (XRD) technique was performed on the material passing the 45- $\mu\text{m}$  (No. 325) sieve. Results indicate very little clay minerals present in the clay-size fraction with the majority of the debris material composed of calcium carbonate (calcite). The crack surface also had traces of calcium chloride ( $\text{CaCl}_2$ ) salt. The salt might have migrated from on the top surface of the deck through surface cracks.

Sieve No.	Percent Retained	Cumulative Percent Retained
8	43.7	43.7
16	17.1	60.8
30	18.0	78.8
50	10.2	89.0
100	5.5	94.5
200	2.7	97.2
325	1.4	98.6
-325	1.4	100

### Preparation of specimens

The laboratory specimens needed to simulate the cracked areas found in real bridges. It is easy to produce a crack. However, its reproduction in laboratory-prepared specimens can be questionable. In order to fulfill this objective, a

sandwich-panel concept was used to make the specimens for the compression, tensile, flexural, and freezing-and-thawing tests. To do this, two slabs were cast separately and bonded, one over the other. The interface between the slabs was modeled as a horizontal delamination like those that might occur in real bridge decks. These specimens were not exactly representative of real delaminations in bridge decks, but were considered to be good enough for simulating this horizontal cracking. After these specimens were prepared, cores and beams were cut out of these sandwich slabs to be tested. The compression and direct-tension tests were performed on core specimens, while the flexure and freezing-and-thawing tests were performed on beam specimens. A detailed description of the sandwich slab preparation is given in a step-wise manner. For the UV-exposure specimen preparation, a different method was used. The method for preparing these specimens is described later in this chapter.

#### **Preparation of sandwich panel.**

- a. *Step 1:* Formwork was prepared to cast the concrete slabs. The size of the individual slabs was approximately 30 in. wide by 3-1/2 in. high by 36 in. long for compression, direct-tension, and flexure tests and 16 in. wide by 1-1/2 in. high by 22 in. long for the freezing-and-thawing test. The maximum surface deviation of the top of the slab was within 0.1 in., as shown in Figure 30. In order to simulate the delaminations in a bridge deck, the top face of the slab was texture-broom finished with a mechanically operated transverse-broom finishing device. This broom consisted of multiple rows of stiff bristles capable of producing striations 1/16 in. deep in the plastic concrete. The striations were uniform in appearance with a spacing approximately equal to their depth and were transverse to the slab centerline. Figure 31 shows a transverse broom-finish operation.
- b. *Step 2:* The slabs were moist-cured for 28 days as per ASTM C 192. Following the curing operation, the broom finish was sandblasted. The surface was abraded to expose the coarse aggregate and remove porous and non-durable paste.
- c. *Step 3:* Two-percent calcium chloride solution was applied evenly on the top surface (rough surface) of each slab. These surfaces were in surface saturation dry (SSD) condition. The 2-percent calcium chloride solution was prepared by dissolving 2 g of A.S.C. reagent-grade calcium chloride (assay 97.9-percent  $\text{CaCl}_2$ , passing an 850- $\mu\text{m}$  (No. 20) sieve and finer) powder in 100 mL of distilled water. The excess solution was then blotted from the top surface of the slab with a towel cloth. Figure 32 shows the spraying of  $\text{CaCl}_2$  solution on a slab specimen.
- d. *Step 4:* A representative amount of debris (0.3 g/in.<sup>2</sup>) was applied over the top surface of the slabs, as shown in Figure 33.

- e. *Step 5:* A bead of epoxy approximately 0.75 by 0.75 in. was placed around the slab, as shown in Figures 34 and 35. This epoxy bead sealed the edges and provided a protective barrier against leakage of polymer around the slab.
- f. *Step 6:* The top slab (prepared with calcium chloride) was placed over the bottom slab (prepared with calcium chloride, debris, and epoxy bead) and compressed, as shown in Figure 36. This applied force was adequate enough to compress the epoxy bead between the top and bottom slab and provide an adequate seal.
- g. *Step 7:* A fast-set epoxy gel was applied around the edge boundary of the delamination to prevent leakage of the injected polymer material.
- h. *Step 8:* Holes were drilled in the top slab in a pattern specified by the polymer material supplier and the injection equipment supplier. The depth of the hole was approximately equal to the depth of the top slab. The drilling equipment had a vacuum attachment so the dust and debris created during drilling was removed immediately. Figure 37 shows the drilling process.
- i. *Step 9:* Plastic injection ports were inserted and glued in the drilled injection holes. Figure 38 shows a finished sandwich slab with injection ports protruding from the top slab.
- j. *Step 10:* Polymer material was injected through the drilled holes until the delamination in the sandwich panel was filled as shown in Figure 39. This was determined by the polymer overflowing from the other injection holes.
- k. *Step 11:* The sandwich panels were air cured for 48 hr after injection.
- l. *Step 12:* Beams were saw cut from the slab specimens for the flexure and freezing-and-thawing tests, and cores were made for the compression- and tensile-test specimens as per requirement.

**Precautions.** It was necessary to take several precautions in the fabrication of the test specimens, as follows:

- a. The debris produced by the drilling process was totally removed from the specimens since this debris has a negative effect on bonding potential of the polymer material.
- b. The caulk provided around the specimen was carefully applied to avoid leakage around the edge of the panel.
- c. Care was taken during saw cutting to avoid excessive damage to the specimens.

**Comments.** The epoxy bead around the slab was not adequate in this specimen preparation. As a result, polymer material was leaking when injected into the delamination. In many cases, voids were created between the top and bottom slabs. This affected some of the test results.

### Laboratory tests

In order to evaluate the performance of the bonding material, the specimens were tested in compression, direct-tensile, flexure, freezing-and-thawing, and UV exposure. Their results were then compared with control specimens. All tests were done according to the ASTM specifications except for the direct-tensile and UV-exposure tests, for which new test setups were created.

**Compression test.** Specimens were obtained by drilling cores out of the sandwich panels as per ASTM C 42. The size of the specimens were 3-3/4-in. in diameter by 7-1/2-in. high. Tests were performed in accordance with ASTM C 39. Figure 40 shows core specimens drilled from a sandwich slab.

**Direct-tensile test: ASTM C 496:** The standard test methods for determining the splitting-tensile strength of cylindrical concrete specimens could not be used to determine the tensile capacity of the glued test specimens. To determine the tensile capacity of these glued specimens, the research team designed a direct-tensile determining device, as shown in Figure 41. The device consisted of two grips connected to a U-bar and tensile rod which applied tensile force to the specimens. All connections were made as pin types to eliminate any bending moment that could occur because of eccentricity of the applied load. A 1/8-in.-thick neoprene pad was used on the inside face of the top and bottom grips to distribute the clamping force evenly on the specimen. This device worked extremely well for these direct-tensile tests. However, there were limitations to this testing device, as follows:

- a. The design strength ( $f'_c$ ) of the concrete mixture used in this project was around 4,000 psi. For this design strength, the device worked well for determining tensile capacity. However, the grip could slip for high-strength concrete specimens.
- b. The delaminations were located at the mid-height of the laboratory specimens. This placement provided adequate grip space to provide gripping force for both the top and bottom grips. If the delaminations were at a shallow depth, it would not be possible to grip the specimens so that the delamination was not covered by one of the two grips.
- c. The size of the specimens was 3-3/4-in. in diameter by 7-1/2 in. high. Figure 41 shows the test setup for the direct-tensile testing device. For specimens with a good quality bond between the concrete and polymer material, failure was expected to occur in the concrete rather than in the interface bond.

**Flexural test.** The objective of the flexural test was to evaluate the modulus of rupture of specimens that were bonded with polymer. Specimens were obtained by sawing beams that were 6 in. wide by 27 in. long by 7-1/2 in. high out of a sandwich panel. Tests were performed according to ASTM C 78. Figure 42 shows a failed-beam test specimen in flexure.

**Freezing-and-thawing test.** The objective of this test was to evaluate the durability of a polymer-injected concrete when exposed to 300 cycles of freezing and thawing. The specimens were obtained by sawing beams that were 3 in. wide by 16 in. long by 3 in. high out of a sandwich panel that was 16 in. wide by 22 in. long by 1-1/2 in. high. The tests were performed according to ASTM C 666, Procedure A.

**UV-exposure testing.** The objective of this test was to quantify and measure the degree of material damage that UV exposure could do to Category I and Category II polymer overlays. In order to do this, a testing environment was created in which polymer-overlaid concrete specimens were exposed to high-intensity UV radiation for a specified amount of time. Thus, specimens were produced that were equivalent to and representative of polymer overlays that had been exposed to natural sunlight UV radiation for much longer periods. Once this exposure process was performed, additional testing was done on the specimens to evaluate any material damage and changes in physical properties that might have resulted. It should be noted that for this testing, only UV exposure was considered and no other environmental effects, such as the presence of moisture, were considered in combination with this UV exposure.

The experimental UV-exposure chamber used for the specimens in this test is shown in Figure 43. This chamber was constructed from wood, and the UV light bulbs were mounted on the inside faces of the A-shaped top portion of this system. Figure 44 shows this setup. The test specimens were then placed on a rack inside this top portion so that the polymer overlays faced the UV bulbs. See Figure 45 for this arrangement. Aluminum foil was also placed on the wood, as shown in Figure 45, so that reflection would occur.

The actual preparation and UV-exposure testing of the specimens were as follows. Six concrete slabs were overlaid with polymer coatings, each slab having a different type of polymer overlay. These polymers were classified as being either Category I or Category II. There were three types of both Category I and II polymers, which included the Sika, Unitex, and Transpo brands. Three cores were cut from each of these six slabs for UV testing. Two cores of each type (twelve cores total) were placed inside the UV-testing setup. These cores were positioned at approximately 2 in. from the UV-340 testing bulbs. The UV lights were then activated and allowed to run for 24 hr a day for 6 weeks straight. This exposure was equivalent to approximately 1 year of UV light in Florida according to the manufacturer of the UV bulbs. Once this 6-week testing period was completed, these cores with the UV-exposed polymer coatings were evaluated by means of the permeability test procedure

and were then compared to their respective cores with the same polymer overlay but without UV exposure (the six control cores).

### Test results and calculations

**Compression test.** The compressive strength of the specimens was calculated by dividing the maximum load carried by the specimens during the test by the average cross-sectional area of these specimens. If the specimen length-to-diameter ratio is less than 1.8 for this type of test, a correction factor to calculate the compressive strength is typically needed. In this test, the diameter was 3.5 in. for all the suppliers' specimens and 4 in. for the control specimens. The length-to-diameter ratio of the specimens was more than 1.8 for all cases, so no correction factor was needed.

The compression test results for the control specimens are given in Table 2, and the results for the test specimens made with Unitex, Transpo, and Sika are given in Tables 3, 4, and 5, respectively.

The results for the compressive strengths of these materials varied from 5,360 to 3,850 psi average. Unitex recorded the highest compressive strength for this test. This shows a wide range for the compressive strength of the suppliers' specimens (60 percent to 90 percent of the control specimens).

**Direct-tensile test.** The tensile strength of the specimens was determined by dividing the maximum load carried by the specimen during the test by the average cross-sectional area of these specimens.

The tensile-test results are listed in the following. The results for the control specimens are given in Table 6, and the results for the test specimens made with Unitex, Transpo, and Sika are given in Tables 7, 8, and 9, respectively.

The overall performance of the tensile-test results were very good. The stress range varied from 160 to 510 psi with the Transpo specimens performing the best.

<b>Table 2 Compression Test (Control Specimens)</b>			
<b>Specimen No.</b>	<b>Height, in.</b>	<b>Load, lb</b>	<b>Stress, psi<sup>1</sup></b>
1	7.50	71,480	5,690
2	7.50	88,820	7,070
3	7.50	69,230	5,510

<sup>1</sup> Average = 6,090 psi; standard deviation = 850 psi.

**Table 3  
Compression Test (Unitex)**

Specimen No.	Height, in.	Load, lb.	Stress, psi <sup>1</sup>
U 7-8	7.25	58,280	6,060
U 7-12	7.38	35,700	3,710
U 7-4	7.38	56,680	5,890
U 7-14	7.38	40,800	4,240
U 7-17	7.38	42,820	4,450
U 7-23	7.38	58,680	6,100
U 7-25	7.25	59,160	6,150
U 8-4	7.25	58,500	6,100
U 7-6	7.38	58,260	6,160
U 8-16	7.38	39,780	4,140
U 8-5	7.38	60,580	6,300
U 8-6	7.38	31,680	3,290
U 7-13	7.38	33,180	3,450
U 7-16	7.38	61,100	6,350
U 8-9	7.38	58,060	6,030
U 8-1	7.38	42,480	4,420
U 8-4	7.25	55,040	5,720
U 8-22	7.25	54,660	5,680
U 8-15	7.38	59,980	6,230

<sup>1</sup> Average = 5,360 psi; standard deviation = 1,070 psi.

**Table 4  
Compression Test (Transpo)**

Specimen No.	Height, in.	Load, lb	Stress, psi <sup>1</sup>
T3-10	7.38	34,200	3,560
T3-9	7.38	36,900	3,840
T8-24	7.38	55,220	5,740
T8-23	7.17	38,960	4,050
T3-7	7.17	34,560	3,590
T3-20	7.38	40,340	4,190
T8-11	7.38	35,420	3,680
T3-6	7.38	39,380	4,090
T3-15	7.25	38,840	4,040
T3-24	7.25	30,620	3,180
T3-13	7.25	30,940	3,220
T3-5	7.25	33,940	3,530
T3-14	7.25	35,940	3,740
T3-11	7.25	34,280	3,560
—	7.25	37,000	3,850
T3-1	7.25	30,860	3,210
T8-14	7.50	36,000	3,740
T8-5	7.50	28,640	2,980
T3-17	7.50	38,760	4,030
T3-25	7.50	45,560	4,740
T8-1	7.50	48,880	5,080
T8-9	7.50	32,120	3,340
T3-23	7.25	29,660	3,080
T8-6	7.38	41,180	4,280

<sup>1</sup> Average = 3,850 psi; standard deviation = 650 psi.

**Table 5  
Compression Test (Sika)**

Specimen No.	Height, in.	Load, lb	Stress, psi <sup>1</sup>
S6-13	7.38	40,400	4,200
S7-8	7.38	54,600	5,680
S6-11	7.38	51,400	5,340
S6-22	7.38	52,720	5,480
S7-24	7.38	50,940	5,300
S6-20	7.38	21,640	2,250
S6-18	7.38	44,520	4,630
S7-16	7.38	41,700	4,340
S6-5	7.25	39,240	4,080
S7-5	7.25	60,580	6,300
S6-15	7.38	16,060	1,670
S6-6	7.38	50,440	5,240
S6-14	7.38	37,840	3,930
S6-25	7.38	37,160	3,860
S7-20	7.38	36,840	3,830
S7-6	7.25	54,380	5,650
S7-1	7.25	39,880	4,150
S6-21	7.25	38,880	4,040
S6-19	7.38	38,500	4,000
S6-24	7.38	56,960	5,920
S7-11	7.38	36,380	3,780
S7-4	7.25	47,500	4,940
S7-25	7.38	18,960	1,970
S7-21	7.38	30,220	3,140
S6-16	7.38	43,680	4,540

<sup>1</sup> Average = 4,370 psi; standard deviation = 1,220 psi.

**Table 6  
Direct-Tensile Test (Control Specimens)**

Specimen No.	Load, lb	Stress, psi <sup>1</sup>
1	5,950	470
2	6,100	490
3	6,300	500

<sup>1</sup> Average = 490 psi; standard deviation = 10 psi.

<b>Table 7 Direct-Tensile Test (Unitex)</b>		
<b>Specimen No.</b>	<b>Load, lb<sup>1</sup></b>	<b>Stress, psi<sup>2</sup></b>
U7-20	1,100	110
U8-19	3,750	390
U8-23	2,850	300
U7-2	3,900	410
U7-9	2,850	300
U8-12	3,900	410
U7-22	3,000	310
U7-7	3,300	340
U7-4	2,950	310
U8-3	3,550	370
U8-25	3,375	350
U8-10	4,150	430
U7-15	2,200	230
U8-8	3,800	400
U7-21	4,170	430
U8-24	4,350	450
U8-13	4,500	470
U8-7	3,350	350
U7-11	2,810	290
U7-3	4,050	420
U8-18	3,950	410
U8-21	4,650	480
U8-17	4,200	440
U8-20	4,250	440

<sup>1</sup> Average = 3,480 lb; standard deviation = 820 lb.  
<sup>2</sup> Average = 360 psi; standard deviation = 90 psi.

**Table 8**  
**Direct-Tensile Test (Transpo)**

Specimen No.	Load, lb <sup>1</sup>	Stress, psi <sup>2</sup>
T8-15	700	70
T8-13	300	30
T8-8	520	50
T3-19	1,875	190
T3-21	1,700	180
T3-2	1,575	160
T8-3	270	30
T8-19	450	50
T3-16	1,450	150
T8-21	1,700	180
T3-8	1,500	160
T8-22	1,050	110
T8-7	850	90
T8-18	350	40
T8-17	800	80
T8-4	500	50
T8-10	1,100	110
T3-18	1,600	170
T3-22	1,250	130
T3-13	1,550	160
T8-16	1,400	150
T8-12	520	50
T8-2	900	90
T8-20	700	70

<sup>1</sup> Average = 1,021 lb; standard deviation = 116 lb

<sup>2</sup> Average = 510 psi; standard deviation = 50 psi.

<b>Table 9 Direct-Tensile Test (Sika)</b>		
<b>Specimen No.</b>	<b>Load, lb<sup>1</sup></b>	<b>Stress, psi<sup>2</sup></b>
S6-2	1,300	140
S6-8	1,650	170
S6-23	2,700	280
S7-18	1,750	180
S7-22	1,650	170
S7-2	1,450	150
S7-3	1,100	110
S7-12	1,400	150
S6-12	1,150	120
S7-10	2,550	270
S7-7	1,050	110
S7-14	1,550	160
S6-9	1,000	100
S6-1	1,050	110
S7-17	1,100	110
S7-9	1,600	170
S6-7	1,450	150
S7-15	2,500	260
S6-17	2,000	210
S17-19	1,420	150
S7-23	1,430	150
S7-13	1,000	100
S6-3	1,225	130
S6-4	900	90
<sup>1</sup> Average = 1,540 lb; standard deviation = 500 lb. <sup>2</sup> Average = 160 psi; standard deviation = 50 psi.		

**Flexural test ASTM C 78.** If the fracture was initiated in the tension surface within the middle third of the span length, the modulus of the rupture was calculated as follows:

$$R = Pl/bd^2 \quad (1)$$

where

- R = modulus of rupture, psi
- P = maximum applied load indicated by the testing machine, lbf
- l = span length, in.
- b = average width of the specimen, in.
- d = average depth of specimen, in.

If fractures occur in the tension surface outside the middle third of the span length by not more than 5 percent of the span length, the modulus of rupture was calculated as follows:

$$R = 3Pa/bd^2 \quad (2)$$

where

- a = average distance between line of fracture and the nearest support measured on the tension surface of the beam, in.

For testing the specimens, width (b) and depth (d) measurements were taken at three locations, and the average was used. The failure point was noted to use the applicable equations for the stress calculations. The flexural-test results are given in the following tables. The results for the control specimens are given in Table 10, and the results for the test specimens made with Unitex, Transpo, and Sika are given in Tables 11, 12, and 13, respectively.

The suppliers' specimens in general showed good results compared to the control specimens' results, where they obtained a 80-percent to 90-percent range of the control specimens' strength. The stress range varied from 550 psi to 500 psi and Unitex recorded the highest flexural strength. All the specimens failed within the middle third of the span.

**Freezing-and-thawing test.** The fundamental frequency and weight of each specimen were recorded at intervals of 20 to 30 cycles. A corresponding weight was obtained for each fundamental frequency reading. A typical set of readings is given in Table 14 for a specimen which survived the ASTM recommended full 300 cycles without losing 60 percent of the dynamic modulus of elasticity.

The transverse dynamic modulus of elasticity was calculated using the equation given in ASTM C 215, as follows:

<b>Table 10 Flexural Test (Control Specimens)</b>										
Specimen No.	Width, in.			Ave. Width, in.	Depth, in.			Ave. Depth in.	Load, lb	Modulus of Rupture, $ps^h$
	b1	b2	b3		d1	d2	d3			
1	7.00	7.00	7.00	7.00	6.00	6.00	6.00	6.00	5,600	600
2	7.00	7.00	7.00	7.00	6.00	6.00	6.00	6.00	5,700	610
3	7.00	7.00	7.00	7.00	6.00	6.00	6.00	6.00	5,600	600
4	7.00	7.00	7.00	7.00	6.00,	6.00	6.00	6.00	7,300	780
5	7.00	7.00	7.00	7.00	6.00	6.00	6.00	6.00	6,650	610
6	7.00	7.00	7.00	7.00	6.00	6.00	6.00	6.00	7,850	720

<sup>1</sup> Average = 600 psi; standard deviation = 6 psi.

Specimen No.	Width, in.			Ave. Width, in.	Depth, in.			Ave. Depth, in.	Load, lb	Modulus of Rupture, psi <sup>1</sup>
	b1	b2	b3		d1	d2	d3			
	Ave. Depth, in.									
U10-2	5.75	5.75	5.75	5.75	7.25	7.25	7.25	7.25	5,600	500
U10-3	6.00	5.25	5.25	5.50	7.50	7.50	7.25	7.42	6,200	550
U10-4	6.00	5.25	5.25	5.50	7.50	7.50	7.25	7.42	6,200	550
U10-5	5.75	5.75	5.75	5.75	7.50	7.50	7.25	7.42	6,050	520
U10-1	5.75	5.75	5.75	5.75	7.50	7.50	7.50	7.50	5,950	500
U9-1	5.50	5.75	5.75	5.67	7.75	7.50	7.50	7.58	7,500	620
U9-2	6.00	5.75	5.75	5.83	7.75	7.50	7.50	7.58	6,750	550
U9-3	5.25	5.38	5.38	5.34	7.50	7.75	7.75	7.67	6,450	560
U9-4	5.75	6.00	5.75	5.83	7.50	7.75	7.75	7.67	7,700	610
U1-5	6.00	6.00	6.00	6.00	7.50	7.75	7.75	7.67	6,450	500
U1-4	5.50	5.50	5.75	5.58	7.50	7.50	7.50	7.50	7,450	640
U1-3	5.75	5.75	5.75	5.75	7.25	7.25	7.25	7.25	7,800	700
U1-2	5.75	5.75	6.00	5.83	7.50	7.25	7.25	7.33	7,950	690
U9-5	5.50	5.50	5.75	5.58	7.25	7.50	7.50	7.42	7,600	670
U1-1	6.25	6.25	6.25	6.25	7.25	7.25	7.25	7.25	8,250	680
U2-4	5.50	5.50	5.50	5.50	7.50	7.50	7.50	7.50	5,500	480
U2-3	5.75	5.75	5.75	5.75	7.50	7.50	7.50	7.50	5,750	480
U2-2	6.00	6.00	6.00	6.00	7.50	7.50	7.50	7.50	3,200	260
U2-1	5.75	6.00	6.00	5.92	7.00	7.25	7.25	7.17	6,600	590
U2-5	6.00	6.00	6.00	6.00	7.50	7.50	7.38	7.46	5,150	420

<sup>1</sup> Average = 550 psi; standard deviation = 110 psi.

**Table 12**  
**Flexural Test (Transpo)**

Specimen No.	Width, in.			Ave. width, in.	Depth, in.			Ave. Depth, in.	Load, lb	Modulus of Rupture, psi <sup>1</sup>
	b1	b2	b3		d1	d2	d3			
T7-2	5.75	5.50	5.75	5.67	7.50	7.25	7.50	7.42	7,500	650
T7-3	5.50	5.50	5.63	5.54	7.38	7.38	7.38	7.38	7,800	700
T7-4	5.00	5.25	5.50	5.25	7.38	7.38	7.38	7.38	6,450	610
T7-5	6.13	6.38	6.25	6.25	7.38	7.38	7.38	7.38	11,400	910
T7-1	6.13	6.25	6.25	6.21	7.25	7.25	7.25	7.25	11,150	920
T1-5	5.75	5.75	5.75	5.75	7.25	7.50	7.50	7.42	5,850	500
T1-4	5.50	5.50	5.50	5.50	7.50	7.50	7.50	7.50	6,600	580
T1-3	5.75	5.75	5.75	5.75	7.50	7.50	7.50	7.50	5,450	450
T1-2	5.88	5.88	5.75	5.83	7.50	7.50	7.50	7.50	6,800	560
T1-1	5.88	5.88	5.88	5.88	7.50	7.50	7.50	7.50	5,850	480
T5-1	5.38	5.38	5.38	5.38	7.25	7.25	7.25	7.25	4,650	450
T6-5	6.75	6.63	6.50	6.63	7.50	7.00	7.00	7.17	4,650	370
T6-4	5.25	5.25	5.25	5.25	7.00	7.00	7.13	7.04	3,650	380
T6-3	5.50	5.50	5.50	5.50	7.13	7.13	7.13	7.13	4,300	420
T6-2	6.25	6.25	6.25	6.25	7.00	7.00	7.13	7.04	4,700	410
T6-1	5.50	5.63	5.50	5.54	7.13	7.13	7.13	7.13	4,700	450
T4-3	5.88	6.00	6.13	6.00	7.50	7.50	7.63	7.54	5,600	440
T4-2	5.88	5.63	5.50	5.67	7.50	7.50	7.50	7.50	5,800	500
T4-1	5.75	5.63	5.50	5.63	7.50	7.50	7.13	7.38	6,200	550
T5-5	6.25	6.50	6.50	6.42	7.25	7.25	7.50	7.33	6,400	500
T5-4	5.88	5.50	5.25	5.54	7.38	7.38	7.38	7.38	5,250	470
T4-3	5.63	5.75	5.75	5.71	7.50	7.50	7.38	7.46	4,700	400
T5-2	6.13	6.25	6.25	6.21	7.38	7.38	7.38	7.38	6,000	480
T4-4	5.00	5.50	5.63	5.38	7.38	7.38	7.38	7.38	5,100	470
T4-5	5.75	6.00	6.00	5.92	7.50	7.50	7.38	7.46	5,600	460

<sup>1</sup> Average = 530 psi; standard deviation = 150 psi.

**Table 13  
Flexural Test (Sika)**

Specimen No.	Width, in.			Ave. width, in.	Depth, in.			Ave. Depth, in.	Load, lb	Modulus of Rupture, psi <sup>1</sup>
	b1	b2	b3		d1	d2	d3			
S13-1	6.25	6.13	6.00	6.13	7.25	7.25	7.50	7.33	4,350	360
S13-2	6.00	6.00	5.88	5.96	7.25	7.50	7.50	7.42	4,100	340
S13-4	5.00	5.00	5.00	5.00	7.50	7.38	7.38	7.42	8,750	860
S13-5	6.50	6.63	6.75	6.63	7.38	7.38	7.38	7.38	7,850	590
S12-1	5.88	5.88	6.00	5.92	7.75	7.75	7.25	7.58	3,400	270
S12-2	6.13	6.13	6.13	6.13	7.75	7.50	7.25	7.50	3,850	300
S12-3	5.50	5.50	5.50	5.50	7.75	7.75	7.25	7.58	7,050	600
S12-4	5.13	5.13	5.13,	5.13	7.50	7.50	7.50	7.50	3,850	360
S13-3	5.50	5.50	5.50	5.50	7.50	7.50	7.50	7.50	6,050	530
S8-2	5.88	5.88	5.88	5.88	7.25	7.25	7.25	7.25	6,400	560
S9-5	6.13	5.88	5.88	5.96	7.50	7.50	7.50	7.50	4,100	330
S9-4	5.75	5.75	5.50	5.67	7.75	7.75	7.50	7.67	5,600	460
S9-1	5.50	5.50	5.50	5.50	7.50	7.50	7.50	7.50	7,350	650
S9-3	5.75	5.75	5.75	5.75	7.50	7.50	7.50	7.50	5,650	480
S9-2	5.88	6.00	6.00	5.96	7.50	7.50	7.50	7.50	7,550	610
S14-4	5.50	5.50	5.75	5.58	7.50	7.25	7.50	7.42	8,750	770
S14-5	5.75	5.75	5.75	5.75	7.50	7.50	7.50	7.50	7,600	640
S14-2	5.50	6.00	6.00	5.83	7.50	7.50	7.50	7.50	8,950	740
S14-3	5.88	5.88	5.88	5.88	7.50	7.50	7.50	7.50	7,450	610
S14-1	5.25	5.50	5.50	5.42	7.50	7.50	7.50	7.50	8,200	730
S2-5	6.63	6.63	6.63	6.63	7.38	7.38	7.63	7.46	3,250	240
S5-1	6.00	6.00	5.88	5.96	7.38	7.38	7.38	7.38	4,700	390
S5-2	5.63	5.63	5.63	5.63	7.38	7.38	7.50	7.42	5,200	450
S5-3	6.00	6.13	6.13	6.09	7.50	7.50	7.50	7.50	6,100	480
S5-4	5.00	5.00	5.00	5.00	7.50	7.50	7.50	7.50	4,700	450
S8-5	6.00	6.00	6.00	6.00	7.00	7.00	7.50	7.17	4,700	410
S8-4	5.50	5.88	5.88	5.75	7.50	7.50	7.50	7.50	3,900	330
S8-3	5.50	5.88	5.88	5.75	7.00	7.00	7.50	7.17	5,050	460
S8-1	5.63	5.63	5.63	5.63	7.13	7.13	7.25	7.17	5,250	490

<sup>1</sup> Average = 500 psi; standard deviation = 160 psi.

Table 14 Typical Reading for Frequencies and Mass						
No.	Transpo		Sika		Unitex	
	Freq	Mass, lb	Freq.	Mass, lb	Freq.	Mass, lb
0	1,580	15.5	1,590	15.0	1,670	16
14	1,520	15.3	1,550	15.0	1,630	16
31	1,510	15.5	1,510	15.0	1,600	16
45	1,470	15.5	1,470	15.0	1,560	16
63	1,450	15.5	1,430	15.2	1,540	16
80	1,470	15.5	1,470	15.1	1,560	16
93	1,380	15.5	1,440	15	1,580	16
107	1,380	15.4	1,410	15	1,550	15.9
116	1,400	15.4	1,430	15	1,550	15.9
132	1,390	15.4	1,420	15	1,550	15.9
144	1,390	15.4	1,410	15	1,550	15.9
157	1,270	15.3	1,390	14.9	1,480	15.8
175	1,260	15.3	1,380	14.9	1,480	15.8
213	1,240	15.3	1,340	14.9	1,440	15.8
243	1,210	15.3	1,320	14.9	1,420	15.7
265	1,210	15.3	1,290	14.9	1,400	15.7
285	1,150	15.3	1,210	14.9	1,370	15.7
300	1,080	15.3	1,210	14.9	1,360	15.7

$$\text{Dynamic } E = Cwn^2 \quad (3)$$

where

$w$  = mass of the specimen, lb

$n$  = fundamental transverse frequency, Hz

$$C = 0.00245 \left( \frac{L^3 T}{bt^3} \right) \left( \frac{\text{sec}^2}{\epsilon^2} \right) \text{ for a prism} \quad (4)$$

where

$L$  = length of specimen (in.)

$d$  = diameter of cylinder (in.)

$t$  and  $b$  = dimensions in the driving direction and the other cross-sectional dimension, respectively

$T$  = correction factor based on ratio of radius of gyration,  $K$ , to length of specimen and on Poisson's ratio. The radius of gyration

$K$  = equal to  $d/4$  for a cylinder and  $l/3.464$  for a prism

Table 15 gives values of  $T$  for a Poisson's ratio of  $1/6$ . These values are derived from a curve developed by Gerald Pickett (Pickett 1945).

$K/L$	$T$	$K/L$	$T$
0.00	1.00	0.09	1.60
0.01	1.01	0.10	1.73
0.02	1.03	0.12	2.03
0.03	1.07	0.14	2.36
0.04	1.13	0.16	2.73
0.05	1.20	0.18	3.14
0.06	1.28	0.20	3.58
0.07	1.38	0.25	4.78
0.08	1.48	0.30	6.07

The durability factor (DF) was calculated 300 cycles of freezing-and-thawing resistance or the number of cycles at which the units reached 60 percent of their original dynamic modulus. Table 16 gives a typical reading for dynamic modulus of elasticity.

Specimen	No. of Cycles	Mass, lb	Length in.	Thickness in.	Width in.	Freq.	DME <sup>1</sup>	Percent of Initial DME
Transpo	0	15.5	16.25	2.875	4	1,580	5306.6	100
	300	15.3	16.25	2.875	3.75	1,080	2602.1	49
Sika	0	15	16.25	2.875	4.0	1,590	5200.7	100
	300	14.9	16.13	2.875	3.875	1,210	3017.0	58
Unitex	0	16	16.13	3.13	3.75	1,670	4966.6	100
	300	15.75	16.13	3.0	3.75	1,360	3664.8	74

<sup>1</sup> DME = dynamic modulus of elasticity

A total of 28 specimens were tested in freezing-and-thawing cycles. Out of 30 specimens, 8 specimens were Transpo material, 8 specimens were Sika material, and the remaining 12 were Unitex material. Table 17 gives the test results.

<b>Specimen Type</b>	<b>No. of Specimens Tested</b>	<b>Results</b>
Transpo	8	(1) Two specimens failed at 144 and 157 cycles, respectively. (2) Six remaining specimens continued to 300 cycles with an average 43-percent reduction in dynamic modulus of elasticity.
Sika	8	(1) One specimen failed at 132 cycles. (2) Seven remaining specimens continued to 300 cycles with an average 54-percent reduction in dynamic modulus of elasticity.
Unitex	12	(1) One specimen failed at 144 cycles. (2) Two specimens failed at 157 cycles. (3) One other specimen failed at 285 cycles. (4) Eight remaining specimens continued to 300 cycles with an average 51-percent reduction in dynamic modulus of elasticity.

Some failures were attributed to the position of the drilling hole. The specimens were cut from bigger slabs. In some of the specimens, the cutting line was along the drill hole location. Drilling hole locations were the areas of initial weight loss locations for the slab. Concrete in these areas was very soft due to the drilling process. In most specimens, failure started in these locations. Initially, the concrete disintegrated in these locations, eliminating the bonding material between the two slabs. Figure 46 shows the failed specimens.

Because of the gap between the two slabs, discontinuities were established that subsequently reduced the dynamic modulus of elasticity. Failures also occurred in areas where there was a weak bond between adhesive material and concrete.

**UV test.** It was initially expected that the UV light in the experimental testing chamber would cause a certain degree of material damage or change in the polymer physical properties. It was thought that, through permeability testing, this damage would be apparent due to much higher permeability rates for the specimens that had been exposed to the UV light. However, the results from this test proved otherwise. In fact, the permeability rates for the UV-exposed specimens were nearly identical to the specimens that had not been exposed to the UV light. From this, it was concluded that this amount of UV exposure, which was equivalent to 1 year of UV exposure in Florida, did not cause any kind of significant material damage to the three different brands of polymer overlays that were tested. If any damage at all occurred, it could not be detected through this type of permeability testing. In addition to this, no

noticeable color changes or texture changes were apparent in the UV-exposed polymer specimens.

An example of the determined permeability rates for UV-exposed and non-exposed specimens is shown in Figures 47 and 48. It can be seen that this rate was 0.0043 g/hr for the UV-exposed specimen and 0.0046 g/hr for the unexposed specimens. The fact that these rates were so close indicates that no significant damage resulted from the UV exposure for this polymer overlay.

## **Conclusions**

The performance of the polymer bonding materials were evaluated under compression, direct-tensile, flexural, and freezing-and-thawing tests, and the performance of the polymer overlay materials were evaluated when exposed to UV light. The laboratory tests showed that the suppliers' specimens obtained 60 to 90 percent of the compressive strength of the control specimens in the compression test. In these tests, Unitex recorded the highest compressive strength (5,360 psi average).

As mentioned before, there were voids between the slabs due to the leaking of material. Because of this, tensile-test results were grossly affected. However, overall performance of the bond was very good.

The suppliers' specimens showed good results in the flexural test compared to the control specimens' results where they obtained 80 to 90 percent of the control specimens' strength. Unitex recorded the highest strength (550 psi average) in this test.

The performance of injection techniques was satisfactory as far as freezing-and-thawing resistance is concerned. Most specimens undergoing testing survived the full 300 cycles of freezing-and-thawing resistance as per ASTM requirements.

The UV-test results showed that high-intensity UV exposure (equivalent to 1 year of Florida sunlight) did not do significant damage to the Category I and Category II Transpo, Unitex, and Sika overlays. In fact, the permeability rate through the UV-exposed and non-exposed specimens was nearly identical.

## **Laboratory Evaluation of Polymer Materials (Phase II)**

The purpose of the Phase II evaluation was to test another set of tensile-test specimens in which the epoxy barrier was perfectly placed so that none of the injected material leaked from the sandwich slab. The influence of varying the injection pressure in the delaminations was also determined. The test specimens were prepared with the sandwich-panel concept with enough precautions taken

so that there was no leakage at the edges where the epoxy bead bonded the two slabs together. In order to determine the influence of the injection pressure, pressure transducers were placed in the slab. As mentioned earlier, there is no ASTM specification for this kind of tensile test, so a new testing procedure was devised, as will be described later.

### **Details of test specimens and observations**

Altogether, four sandwich slabs approximately 30 in. wide by 3-1/2 in. high by 36 in. long were prepared. In two of the slabs, pressure transducers were introduced as shown in Figure 49. Injection holes were drilled with equipment devised for this research. The hole spacings were kept at 6 in. on center. The purpose of the pressure transducers was to determine the in situ pressure while the material was being injected into the delaminations. The pressure transducers were placed around the perimeter of the slab, and the material was injected through the holes in the center of the slab. As mentioned previously, two kinds of material were evaluated for the bonding capacity: one was high molecular weight methacrylate (HMWM) and the other was epoxy-based material. One slab with pressure transducers was injected with HMWM, and the other with epoxy-based material. These pressure transducers were connected to a computer and data acquisition system to monitor the injected pressure. Figure 50 shows the pressure-monitoring system for the pressure transducers. In addition, the pump pressure and injection nozzle pressure from the injection pressure were recorded manually during the injection process.

The injection process was started with epoxy-based material. Initially, the pump pressure was kept at 30 psi. At the beginning of the injection, the pressure transducers were not detecting any measurable pressure created through the injection process as it was released through other open injection ports. Once the material came into contact with the transducers, they started reading pressures. When the delaminations were filled with the injection material, the pressure at transducers was almost equal to the injection nozzle pressure. The filling of the slab was noted by observation of the outflow of the material through the other injection ports. Once the material began flowing out through these other holes, the holes were capped. The pump pressure was reduced, and injection of the material was continued. This was done to observe the effect of injecting material once the delamination was filled. The injection pressure created diagonal cracks starting at the middle of the slab and progressing towards the corner. The injected materials were flowing out through these cracks. Figure 49 shows a crack in the slab. The injection was stopped at this point, and the pressure was monitored by the transducers for several hours. There was a steady decline in the pressure reading over this period of time. Eventually, the reading stabilized to a constant pressure. This constant pressure was then maintained for several hours. The end pressure reading was higher than the initial starting pressure. The pressure readings from different components were plotted and are shown in Figure 51.

In order to avoid cracking the slab, the injection procedure was modified for the second slab. As mentioned, this slab was injected with HMWM. The pump pressure was maintained between 40 to 60 psi for this slab. Once the transducer reading matched the injection nozzle pressure reading, the injection was stopped to disperse the material evenly. This was done for about 10 min until the transducer pressure reading values returned to the original reading values. The injection process was then started again to fill the remaining unfilled portion of the delamination. Again, the filling of the delaminations was detected by the outflow of injection material through the other ports. The injection process was discontinued at this point. This injection process proved better than the previous process used for the first slab. Figure 52 shows a plot of pressure readings for different components.

The remaining two slabs were injected with the procedure adopted for the second slab. One of these slabs was injected with an epoxy-based material, and the other with HMWM material. The slabs were cured for 48 hr before they were cored into 4-in.-diameter cylinder specimens. These cylinders were then used for tensile testing.

### **Tensile-test results**

Around 25 to 28 cylinders were cored from each slab. The cores were tested using the tensile-test procedure as described previously. The Sika and Transpo materials were each injected into one of the four slabs, and the remaining two slabs were injected with the Unitex material. For Unitex, one slab had the pressure transducers, and the other did not. These slabs were designated as Slab A and Slab B, respectively. Tables 18 through 21 give the tensile-test results with averages and standard deviations.

### **Conclusions**

There was no leakage of injection material at the boundary of the slabs. The procedure for injecting material and allowing it to disperse before a second dose of material was injected worked well. The results of the tensile tests with the use of the specimens cored from these slabs were very impressive. The success of this injection process and these tensile tests made it possible for the research team to write specifications for this type of injection procedure.

## **System Procedures**

As a result of this research, three procedures have been introduced for the repair of delaminated bridge decks. These procedures are the Category-I sealer healer, Category-II surface coating, and the polymer-injection applications. These procedures are defined as follows:

<b>Table 18 Tensile-Test Results (Sika)</b>			
<b>ID</b>	<b>Load, lb</b>	<b>Area, in.<sup>2</sup></b>	<b>Stress, psi<sup>1</sup></b>
S 13	1,700	12.56	140
S 19	1,700	12.56	140
S 20	3,300	12.56	260
S 21	2,600	12.56	210
S 21	1,900	12.56	150
S 22	3,600	12.56	290
S 23	3,600	12.56	290
S 24	3,700	12.56	290
S 25	3,200	12.56	250
S 5	2,400	12.56	190
S 15	3,900	12.56	310
S 10	3,850	12.56	310
S 14	4,050	12.56	320
S 11	3,400	12.56	270
S 9	3,600	12.56	290
S 8	3,600	12.56	290
S 7	4,250	12.56	340
S 6	3,750	12.56	300
S 2	4,000	12.56	320
S 1	4,000	12.56	320
S 3	4,450	12.56	350
S 4	4,000	12.56	320
S 16	4,000	12.56	320
S 17	4,100	12.56	330
S 18	4,050	12.56	320

<sup>1</sup> Average = 280 psi; standard deviation = 60 psi.

- a. *Category I.* This application will penetrate and seal the surface and fill surface cracks. An aggregate may be applied to prevent a skid-resistance problem, but the system is designed to allow the aggregate to absorb the excess sealer materials and then quickly wear from the surface.
- b. *Category II.* This application will seal and bond to the deck surface, fill surface cracks, and provide a long-lasting, skid-resistant, new wearing surface for the deck.

<b>Table 19 Tensile-Test Results (Transpo)</b>			
<b>ID</b>	<b>Load, lb</b>	<b>Area, in.<sup>2</sup></b>	<b>Stress, psi<sup>1</sup></b>
TR 10	1,700	12.56	140
TR 11	3,100	12.56	250
TR 12	2,000	12.56	160
TR 13	1,600	12.56	130
TR 14	2,400	12.56	190
TR 15	2,100	12.56	170
TR 16	2,350	12.56	190
TR 18	1,500	12.56	120
TR 19	1,700	12.56	140
TR 2	2,300	12.56	180
TR 20	1,250	12.56	100
TR 21	3,500	12.56	280
TR 22	1,300	12.56	100
TR 24	1,800	12.56	140
TR 25	2,000	12.56	160
TR 3	1,850	12.56	150
TR 4	2,250	12.56	180
TR 5	2,300	12.56	180
TR 6	1,200	12.56	100
TR 7	1,800	12.56	140
TR 8	1,600	12.56	130
TR 9	1,450	12.56	120
TR 1	3,100	12.56	250
TR 17	2,350	12.56	190
TR 23	1,375	12.56	110

<sup>1</sup> Average = 160 psi; standard deviation = 50 psi.

- c. *Polymer injection.* Polymer material is injected into bridge-deck locations where delaminations are present to adhere the concrete deck back together. This helps to restore deck strength and serviceability.
- d. *Equipment and procedures.* This section provides a description of the necessary equipment and procedures that are involved in applying the Category-I, Category-II, and the injection processes. Several photographs and figures previously given are referred to in this section to illustrate the equipment and procedures. These photographs and figures show the actual application of the Category-I, Category-II, and injection processes for the Michigan, Mississippi, and Kansas demonstration projects.

## **Procedures for Category-I sealer healer**

A brief description of the equipment and supplies needed for the Category-I sealer healer application follows. The procedures involved for this type of polymer application are discussed here as well. A guide specification for Category I from Michigan DOT is provided in Appendix D.

### *a. Equipment required for Category-I sealer healer:*

- (1) Sandblaster.
- (2) Air-fed helmet.
- (3) Coveralls and face respirator.
- (4) Brooms 36 in. long.
- (5) Putty knives.
- (6) Paddles for mixing.
- (7) Regular squeegee.
- (8) Paint brushes.
- (9) Traffic control equipment.
- (10) Tool kit.
- (11) Duct tape 3 in. wide.
- (12) Buckets.
- (13) Emery stone.
- (14) Hand cleaner.
- (15) Garbage bags.

### *b. Step 1: bridge-deck surface preparation:*

- (1) Identify the spalls and remove all the debris from the spalls.
- (2) Make saw cuts around the spalls to chip off the weak concrete around the spalls.
- (3) Clean exposed reinforcement thoroughly by brushing.

**Table 20  
Tensile Test Results (Unitex Slab A)**

ID	Load, lb	Area, in. <sup>2</sup>	Stress, psi
UA	1,200	12.56	100
UA 1	1,250	12.56	100
UA 12	2,000	12.56	160
UA 13	1,800	12.56	140
UA 19	2,600	12.56	210
UA 2	1,500	12.56	120
UA 20	1,250	12.56	100
UA 23	1,650	12.56	130
UA 3	2,150	12.56	170
UA 4	2,400	12.56	190
UA 5	2,300	12.56	180
UA 6	1,800	12.56	140
UA 8	2,800	12.56	220
UA 9	1,700	12.56	140
UA 22	3,400	12.56	270
UA 17	3,200	12.56	250
UA 18	3,150	12.56	250
UA 5	3,550	12.56	280
UA 14	3,200	12.56	250
UA 24	3,900	12.56	310
UA 25	3,550	12.56	280

<sup>1</sup> Average = 190 psi; standard deviation = 70 psi.

- (4) Patch the area. (The patch material used should be as per the specification of the material supplier so that the flood-coat material is compatible with the patch material. In many cases, quick-set patch materials react with Category-I sealer healer materials.)

*c. Step 2: sandblasting the bridge deck:*

- (1) Sandblast the bridge to remove all loose debris, tar, and oil spots.

<b>Table 21 Tensile Test Results (Unitex Slab B)</b>			
<b>ID</b>	<b>Load, lb</b>	<b>Area, in.<sup>2</sup></b>	<b>Stress, psi<sup>1</sup></b>
UB 15	2,500	12.56	200
UB 10	2,400	12.56	190
UB 11	2,700	12.56	210
UB 12	2,300	12.56	180
UB 14	2,300	12.56	180
UB 16	3,200	12.56	250
UB 17	2,800	12.56	220
UB 18	2,800	12.56	220
UB 19	2,200	12.56	180
UB 2	2,200	12.56	180
UB 20	3,200	12.56	250
UB 21	2,600	12.56	210
UB 22	1,600	12.56	130
UB 23	3,150	12.56	250
UB 24	2,400	12.56	190
UB 3	2,350	12.56	190
UB 4	2,600	12.56	210
UB 5	2,200	12.56	180
UB 9	2,100	12.56	170
UB 7	4,200	12.56	330
UB 1	4,350	12.56	350
UB 13	2,850	12.56	230

<sup>1</sup> Average = 210 psi; standard deviation = 50 psi.

- (2) Set sandblaster operating pressure at about 140 psi with two 3/8-in.-diam nozzles and two 2-in. air line (the air line should be about four times the diameter of the nozzle size).
- (3) Place the air compressor upwind of the work.
- (4) Use an oil trap on the blaster.
- (5) Use an after cooler to cool the temperature of the supply air to within 10 deg of the ambient temperature.
- (6) Protect the operator with an air-fed helmet and coveralls.

*d. Step 3: cleaning the deck after sandblasting:*

- (1) Remove the sand residue on the surface of the deck by using a front-mount motorized brush.
- (2) Airblast any remaining debris from the surface (similar to the sandblasting procedure except without sand).
- (3) Use the test method prescribed in ACI 503 R to determine the cleaning practice.

*e. Step 4: flood coating and aggregate broadcasting:*

- (1) Mix the coating materials.
- (2) Pour the mixed material over the concrete deck surface and apply evenly with brushes and a 3/16-, 1/4-, 1/8-in. (depending on material used) notched squeegee (or a paint roller).
- (3) Broadcast fine Black Beauty aggregate by hand (throwing it up into the air and letting the fines blow off and the larger material settle into the surface) over the flood-coating material before it becomes too tacky to absorb excess flood-coat material from the surface, as well as increase the frictional resistance of the surface.
- (4) Select a quantity of aggregates used on different coating materials. The standard size of aggregate should pass through an U.S. Standard 1.18-mm (No. 16) and be retained on 850- $\mu\text{m}$  (No. 20) sieve.

*f. Step 5: finishing:*

- (1) Allow the material to take an initial set and lightly brushed off the excess aggregate.
- (2) Cure the flood-coating material for 4 to 5 hr before opening to traffic. Figure 53 illustrates a finished bridge deck after the flood-coat application. Figure 54 illustrates a finished surface after the Category-I sealer is applied.

### **Procedures for Category-II surface coating**

The equipment and supplies necessary for performing the Category-II surface coating application are listed in the following. The application procedure steps are also given here.

*a. Equipment required for Category-II overlay:*

- (1) Shotblaster.
- (2) Air-fed helmet.
- (3) Coveralls and a face respirator.
- (4) Brooms.
- (5) Blades.
- (6) Paddles for mixing.
- (7) Regular squeegee.
- (8) Notched squeegee (depends on site temperature).
- (9) Paint brushes.
- (10) Traffic control equipment.
- (11) Tool kit.
- (12) Duct tape.
- (13) Buckets.
- (14) Emery stone.
- (15) Hand cleaner.
- (16) 1/2-in. drill.

*b. Step 1: bridge-deck surface preparation:*

- (1) Identify the spalls and remove all the debris from the spall.
- (2) Make saw cuts around the spalls to chip off the weak concrete around the spalls.
- (3) Clean exposed reinforcement thoroughly by brushing.
- (4) Patch the material. (The patch material used should be as per the specification of the material supplier so that the flood-coat material is compatible with the patch material.)

- c. *Step 2: shotblasting the bridge deck:*
- (1) Shotblast the bridge deck to a full amplitude of about 1/4 in. The shotblasting should be unidirectional in order to take the concrete surface off to an aggregate profile of about 1/4 in.
  - (2) The speed of the shotblaster should be such that required finishing is provided in the bridge deck.
- d. *Step 3: cleaning the deck after shotblasting:*
- (1) Remove the sand residue on the surface of the deck with a broom or brush.
  - (2) Airblast any remaining debris from the surface if required (similar to the sandblasting procedure except without sand).
  - (3) Use the test method prescribed in ACI 503 R to determine the cleaning practice.
- e. *Step 4: flood coating and aggregate broadcasting:*
- (1) Mix the coating materials.
  - (2) Pour the mixed material over the concrete deck surface and apply evenly with brushes and a 3/16-, 1/4-, or 1/8-in. (depending on material used) notched squeegee (or a paint roller) as the first coat. See Figure 55.
  - (3) Broadcast fine Black Beauty aggregate by hand (throwing it up into the air and letting the fines blow off and the larger material settle into the surface) within certain time over the flood-coating material to absorb additional flood-coat material from the surface, as well as increase the frictional resistance of the surface.
  - (4) Select a quantity of aggregates used on different coating materials. The standard size of aggregate should pass through a U.S. Standard 1.18-mm (No. 16) and be retained on a U.S. Standard 850- $\mu$ m (No. 20) sieve.
  - (5) Remove the unbonded aggregates from the deck surface by brushing after the first coat was applied and cured for 2 to 3 hr.
  - (6) Apply the second coat for the additional material layer and then after a few minutes apply the fine aggregate. The two-coat overlay provides a 1/4-in.-thickness to the deck. Figure 55 shows a finished surface after the material was applied.

*f. Step 5: finishing:*

- (1) Allow the material to take an initial set and lightly brush off the excess aggregate.
- (2) Cure the second coating material for 10 to 12 hr before opening to traffic.

**Procedures for polymer injection**

The equipment and supplies needed for the polymer-injection process are listed below along with the steps for polymer-injection application for bridge decks.

*a. Equipment and supplies required for polymer injection:*

- (1) Drill with impact and rotary system with vacuum attachment.
- (2) Regular shop vacuum.
- (3) Chain drag.
- (4) Brick hammer.
- (5) Pachometer.
- (6) Caulk savers.
- (7) Short knives.
- (8) Steel knife.
- (9) Putty knives.
- (10) Solvent.
- (11) Blades.
- (12) Screwdrivers.
- (13) Paddles for mixing (material supplier).
- (14) Large propane torch.
- (15) Traffic control equipment.
- (16) Tool kit.

- (17) Drill bits.
  - (18) Hand cleaner.
  - (19) Gloves.
  - (20) Plastic garbage bags.
  - (21) Rags.
  - (22) Compressor  $\frac{1}{2}$  HP minimum.
  - (23) Generator to run transformer connection.
- b. *Step 1: preparation of concrete surfaces:*
- (1) Remove all loose material and accumulations of grease, oil, soil, and the like.
  - (2) Seal cracks and patch spall areas.
  - (3) Grind off surface containments and paints in and around mark ports prior to drilling injection ports.
- c. *Step 2: location of delaminations and reinforcement bars:*
- (1) Locate the delaminations by sounding with a chain drag and/or other appropriate equipment.
  - (2) Mark the outline of delaminated areas with a lumber crayon.
  - (3) Determine and mark the location of reinforcing bars with a pachometer.
- d. *Step 3: pattern of injection ports:*
- (1) Locate the injection holes a minimum of about 12 in. between holes.
  - (2) Mark the location of the holes with chalk. Avoid use of potential bond breaker between the concrete and the adhesive used to set injection ports.
- e. *Step 4: drilling and setting ports.* An impact hammer rotary drill should be used with a vacuum attachment to remove concrete fines that may contaminate the delamination area. Drill as nearly perpendicular as possible. A guided drill system with an automatic feed will ensure that the holes will be perpendicular, while drilling the holes by hand

will be much less accurate. Look in the drill hole to see if the hollow plane is visible. The hole need not be much deeper than the hollow plane, usually less than 3 in. and usually less than 1-1/2 in. An automatic drill system will generally drill the hole faster and more accurately than drilling by hand. More production can be achieved by having more than one drill system, as opposed to a gang or multiple drill setup. Hole spacing is too inconsistent to use a gang or multiple drill setup. Holes should be drilled 1/2 in. in diameter and deep enough to reach the delamination. Liquid Control's tapered drill port base should be inserted into the drilled hole so as to be a tight fit. Once inserted, a quick-setting epoxy paste should be used to bond the port to the deck. The epoxy should be mounded up onto the port neck approximately 1/2 to 3/4 in. high and spread in a circular pattern around the port base approximately 3/4 to 1 in. in diameter. The same epoxy should be used to cap any surface cracks that may be detectable on the neck. The epoxy should be spread out to 3/4 to 1 in. on each side of the crack. A narrow blade or trowel 2 to 3 in. wide works best for spreading the epoxy. Once the ports are set, ample time should be given for the epoxy to harden and cure prior to injecting the delamination. When Unitex (ProPoxy 300 Fast) was used at 60 °F, ports were secured adequately within 3 hr.

*f. Step 5: injection and injection pressure.*

- (1) The injection machines can be set up to dispense at a 2:1 or 1:1 volumetric ratio by mechanically changing pistons and metering tubes. The machine should be loaded and primed as outlined in Liquid Control's operations manual. Machine air-pressure settings are to be manually regulated and adjusted on the high/low pressure transducer detection panels. High-pressure setting for air should be between 60 to 80 psi. Low-pressure setting for air should be between 20 to 30 psi. The fluid injection pressure is sensed through fluid, injection pressure is sensed through the transducer mounted off the mixer shroud adapter. The transducer cut-off pressure can be set through a digital Sensotec control display. The transducer cut-off point for high pressure should be set somewhere between 80 to 180 psi. The Posiratio® mini-crack injection machine has a power factor of approximately 5:1; therefore, the line pressures exceed the regulated air pressures on the machine. When the line pressure exceeds the desired transducer setting, the injection machine air pressure will automatically be kicked down to the low air pressure of 20 to 30 psi, thus reducing the line pressure so as not to pop the deck. Injection into the delamination should be completed at the reduced pressure. Injection of a delamination is ideally completed when material has been visually seen oozing from all adjacent ports inserted in the delaminated area and

capped or when ports will not readily take any more material and the injection machine is stalled after all ports are capped off.

- (2) Port connections are made via Liquid Control's port T connector (part # 84/0500/96). A relief valve is connected via the whip hose off the T as well. This offers pressure relief, which is required when removing the connector from a topped off port. Also, the valve allows for material purge from lines connected to tight delaminations where mixed material may dwell beyond the gel time of the resin. More than one port connection can be made with the use of a manifolding technique off a single injection machine. The use of the port T connectors and whip hose can be configured to manifold the material lines. It is not recommended to go beyond injecting three ports simultaneously as it may become too difficult to monitor individual port activity. Port shut-off relief valves should be installed prior to each port connection when manifolding. This will allow operators to monitor flow to individual port connections at any given time.
  
- (3) Injection of the low-viscosity injection resins begins by connecting to one port located at the lowest point in the delaminated area. This will allow resin to travel uphill to the next adjacent ports. Once the connection has been made, inject resin until the port refuses material. Ports will either take material or they will not. If the pump is stalled, then the material has nowhere to go. Either the delamination has been missed when drilling down, or the delamination is blocked with fines due to poor drilling technique or internal debris. In this case, move the port connector to the next adjacent port uphill. Cap off the blocked port. Do not waste time on ports that do not take material readily. Do not go from one port to the next unless the port refuses material. Material will travel up through the delamination from one point of entry. If a port is taking material, do not stop until a stalled condition occurs. The mechanical connection from port connectors to port allows the operator to move around while the injection is taking place. Material will be seen oozing from the series of ports up the deck. The operator will begin capping the ports that begin emitting resin. When all ports are capped, ideally the machine will stall at the kicked-down injection pressure, and thus the delamination is filled. When manifolding, line up the port connections in a straight line at the lowest point in the delaminated deck area and follow the same procedure outlined.

*g. Step 6: finishing:*

- (1) Scrape up any injection epoxy from the deck surface with a spatula.

- (2) Sprinkle the wet area with mortar aggregate to reduce slickness.
- (3) Clean the injection equipment.
- (4) After the required curing time, remove the protruding plastic ports from the bridge deck with grinders or truck-mounted blades.
- (5) Open the bridge to traffic.

## **Demonstration Projects**

Three demonstration projects were organized with the help of Michigan, Mississippi, and the Kansas DOTs to test the feasibility and effectiveness of polymer overlay and injection using a number of different types of polymer products. These three states represent three different geographical and climatic conditions, Michigan being the high snow-fall state, Kansas being a moderate climatic state, and Mississippi having mild climatic conditions. Bridge decks with significant damage were selected in these states. The demonstration projects for each of these three states are described within this section. Figures of the equipment used and of the procedures involved are also provided. In addition, comments and conclusions are given for each of these demonstration projects based on the observations that were made in the field as the overlay and injection procedures were performed.

The first demonstration project of this repair technique was organized in association with the Michigan Department of Transportation (MDOT), Saginaw District. This demonstration project began on 17 July 1995 and continued through 21 July 1995. The second demonstration project was organized in association with the Mississippi Department of Transportation (Mississippi DOT). This demonstration project began 16 October 1995 and lasted for 1 week. The third demonstration project for this repair technique was organized in association with the Kansas Department of Transportation (KDOT). This demonstration project began 24 June 1996 and lasted for 4 days. The goal of all of these demonstration projects was to evaluate the process for the injection and seal coats. These demonstration projects were to evaluate the performance of different materials available on the market and to also evaluate the performance of these repair techniques.

There were four material suppliers who were involved in these demonstration projects in addition to the suppliers for injection equipment and injection hole drilling equipment. However, one material supplier was not available for the Mississippi and Kansas projects.

## Description of bridges

The Michigan demonstration project had three bridges selected for the application of polymer repair. Two of these three bridges were located near Midland, MI, which is about 12 miles northwest of Saginaw over U.S. Hwy 10. These two bridges were the Carter Road Bridge (MDOT S05 09101) and the Eleven Mile Bridge (MDOT ID S06 09101). These bridges were built in 1958 and are typical four-span overpass structures supported by reinforced curved girders with monolithic concrete slab decks. No visible cracks were noticed on the under side of the decks. The deck thicknesses were about 9 in. For deck replacement, Michigan DOT follows a bridge rating which has a scale from 3 to 11 with 11 being a newly built bridge deck without any deterioration. If the rating falls below 4, then the deck becomes a candidate for the replacement. The estimated rating for these two bridges was between 7 to 8 (MDOT source). Surface spalls and horizontal cracks were seen on the top deck surface for both bridges. There were more spalls on the north bound lane of the Eleven Mile Road Bridge than on the south bound lane. Spalls and cracks were uniform throughout the surface of the Carter Road Bridge. MDOT uses deicing salts during the winter season. These salts are mainly sodium chloride; however, calcium chloride is used if the temperature falls below -15 °F. Both of these bridges were nearly identical and were selected for the flood-coating application.

Another bridge near Flint, MI, on the I-475 ramp to south bound I-75 (MDOT ID S35 25132) was selected for evaluation of the injection repair technique. This is a curved steel-plate girder bridge. The bridge-deck condition was very poor, with spalls and cracks throughout. The bridge is super-elevated in the transverse direction with the north edge being higher than the south edge. The deck delaminations of this bridge were detected by MDOT by means of the chain drag method. There were more spalls and delaminations found on the south edge of the bridge than on the north edge, mainly because of the super-elevation of the bridge. Total delaminations were about 27 percent of the total bridge-deck area.

For the Mississippi demonstration project, one bridge was selected for both the Category-I and Category-II flood coating. This bridge is about 2 miles north of Batesville, MS, on the I-55 southbound lanes over the Tallahatchie River. Built about 30 to 40 years ago, it is a seven-span bridge with a total length of 480 ft. The inside main three spans are over the river, and there are two added approach spans on each side. The inside spans are built with reinforced box girder systems. The approach spans are a conventional concrete I-girder system. The shoulder width is very narrow, unlike the modern conventional interstate bridges. The condition of the transverse joints of the bridge was very severe with big pot holes in quite a few locations. The surface of the bridge was in good condition with a few pot holes.

Another bridge located 60 miles northeast of Batesville on U.S.-78 at Ingrams Mill road was selected for demonstration of the polymer injection.

The Ingrams Mill road bridge was 21 years old at the time of the project. It is a four-span two-lane overpass bridge with a total length of about 300 ft. The bridge is supported by five lines of AASHTO prestressed concrete girders. There were spalls observed over much of the bridge-deck surface and aggregates protruding out of the slab deck and the barriers. Aggregates used in the concrete for the bridge were lightweight river gravel. The gravel was a chert material with a noted reputation of being highly susceptible to damage from freezing and thawing. The spalls on the bridge-deck surface were thought to be due to the soft aggregate components. Cold patched areas were found in a few spots.

Three bridges were involved in the Kansas demonstration project. All bridges were slab bridge systems. KDOT personnel reported that slab bridges had been a commonly used bridge system in Kansas because of the abundance of raw materials for concrete found in the state. One bridge was selected for Category-I (Structure No. 50, Osage County), one for Category-II flood coating (Structure No. 114, Shawnee County), and another for injection application (Structure No. 110, Shawnee County). All bridges are located on U.S. Hwy 75. One bridge was on the north-bound lanes, and the other two were on the south-bound lanes. These bridges are located within a 12- to 14-mile distance from Topeka, KS.

### **Strategies for demonstration projects**

Various materials were available in the market that were ideally suited for this type of repair technique. These materials were divided into two main groups: one was the epoxy-based resin and the other was HMWM resins. Two of the four material suppliers associated with this project provided epoxy-based materials, while the other two provided HMWM products. The purpose was to evaluate the performance of the repair technique as well as to evaluate the performance of some of the products available in the market.

In order to evaluate the performance of these products and the effectiveness of these repair techniques, it was necessary to do testing on pretreatment and posttreatment cores. The overlay products were expected to control the infiltration of water into the bridge decks. The injection materials were expected to bond the delaminated deck portions together and restore some of the original strength to these decks. The core locations on the bridges are shown in Figures 53 through 61. The following tests were performed on core specimens.

**Tests on pretreatment core samples.** Permeability and tensile tests were performed to determine permeability and tensile strength of the deck concrete. These results were used as a control parameter to be compared to the permeability and tensile strength of the treated core samples. In addition, petrographic analysis of core samples was done to determine the cause of deterioration of the bridge decks.

**Tests on posttreatment core samples.** Three different sets of tests were performed for three different applications, i.e., Category-I sealer healer, Category-II overlay, and injection repair. Permeability tests were performed on Category-I application cores. Also, petrographic fracture mapping and image analyses were done to determine the location of fracture and penetration of applied materials into the bridge deck.

Permeability and tensile tests were performed in the case of Category-II applications. The tensile tests were performed to determine the tensile strength of the bonded surface between the deck and the overlaying material. Petrographic fracture mapping and image analyses were done for the same reason as for the Category-I sealer healer.

For injection repair cores, tensile tests were performed. These tests indicated the bond strength developed between the concrete and the injection material. If the cores failed in bond, a failure plane analysis was done. Petrographic fracture mapping and image analyses were done on a few core samples to determine the impregnation of injection material.

### **Application of material**

Equal areas were allocated for the different material suppliers to apply their materials for this repair. Control areas were kept aside to evaluate and compare the effectiveness of the repairs. The following paragraphs describe application of the repairs in the three different states.

**Michigan project.** It was planned to use the flood-coating materials on the south-bound lanes only and keep the north-bound lanes as control areas. The south-bound lane was divided into two separate areas for the two different material suppliers. Each material supplier received approximately 1,250 ft<sup>2</sup> of bridge surface for their material application. Prior to this demonstration project, chain-drag surveys were conducted on these bridge to locate the delaminations. Spall areas were patched by the procedure described earlier. A corrosion inhibitor was used along with the primer material, which was painted on the reinforcing bars. For these bridges, a quick-setting patch material called Sika Set was used. This material had a cure time of 4 to 5 hr. Sandblasting in conjunction with air blasting was done in order to remove debris from the surface of the decks. Figure 62 shows a clean bridge surface. Once the bridge deck was cleaned, it was ready to receive the flood-coating material. Fine aggregate was broadcasted by hand over the flood-coating material to absorb the excess material from the surface as well as to increase the frictional resistance of the surface. Black Beauty aggregate was used for this application. Figure 55 shows a finished bridge deck.

For the injection application, material suppliers were each given about 200 ft<sup>2</sup> of delaminations to be repaired by injection on the I-475 ramp. A large untreated control area was kept between each of the material suppliers' areas so

that the injected materials did not interfere with each other. This procedure also helped to differentiate between the treated and untreated areas. Figure 63 shows the injection application on the Michigan bridge.

The injection process was started by marking the injection hole locations on the bridge surface. A rotary drilling with vacuum attachment was used to drill holes. However, this equipment did not work well whenever hard aggregate was encountered because the drill bit did not penetrate through it. Eventually, an impact drill with a vacuum attachment was used to drill the holes. Plastic injection ports were installed over the drilled holes with an epoxy material. The injection process was started as soon as the epoxy around the ports was cured. The injection pressures were monitored through pressure gauges attached to the injection equipment. The injection process was continued until the ports stopped accepting any more material.

**Mississippi project.** The I-55 south-bound bridge was considered for both evaluation of Category-I healer sealer and Category-II overlays. Figure 64 shows the layout of the areas of Category-I healer sealer and Category-II overlays for the different material suppliers. All four material suppliers participated in the Category-II overlay; however, only three suppliers participated in the Category-I sealer healer. For Category-II overlay application, each supplier was given approximately 200 ft<sup>2</sup> of area. Two areas were located at the south end of the bridge, and the other two were located at the north end of the bridge. For Category-I sealer healer application, each supplier was given approximately 1,200 ft<sup>2</sup> of area. All the application areas were located in only one lane of the bridge, and the other lane was kept as a control area. In addition, each application area was separated by a control area.

As mentioned previously, the I-55 south-bound bridge did not have extensive spalls, so patching was not necessary. However, small spalls were patched by the respective materials of the material suppliers during the time of the overlay. The sand blasting that followed was done by brushing and air blasting to remove the sand sticking to the deck surface.

Once the bridge deck was clean, it was ready to receive the overlaying materials. Figure 65 shows material application on the I-55 bridge deck. It was allowed to cure for a few minutes before fine aggregate was applied. Figure 67 shows a finished surface after the Category-I sealer healer was applied.

Unlike the Category-I sealer healer, the Category-II overlay needs a rough deck surface preparation. In this demonstration project, sand blasting was used to prepare the deck surface because of the lack of equipment for shot blasting. The procedure for deck preparation was kept similar to that for Category-I; however, two rounds of sand blasting were done to expose some of the deck aggregates. The first pass of sand blasting was done in the longitudinal direction followed by a transverse pass.

The viscosity of the material for Category-II overlay is generally much higher than for the Category-I sealer healer. Figure 67 shows material application on the surface. After the first coat was applied and cured for 2 to 3 hr, brushing removed unbonded aggregates from the deck surface. The second coat was applied for the additional material layer. Figure 68 shows a finished surface after the material was applied. The two-coat overlay provided a 1/4-in. thickness to the bridge deck. Figure 69 shows some of the postapplication cores.

Similar to the case of the Michigan bridges, a chain-drag method was used to detect the delaminations in these bridges. The injection holes were located over these delamination areas. An automatic drill system with an electric rotary/impact drill with a vacuum attachment was used in this demonstration project. Figure 70 shows the drilling machine. Once the holes were drilled and cleaned, plastic injection ports were inserted and glued to the surface using a quick-set epoxy. Two sets of injection ports were used in this demonstration project. One was a surface port that had a flat base at the bottom, and the other had an elongated base that could be inserted into the drilling hole.

The injection process began once the epoxy around the ports was cured. The pressure in the injection nozzle was monitored through pressure gauges attached to the injection equipment. The injected material in the bridge cured for 6 to 7 hr before the protruding plastic ports were removed and the bridge was opened to traffic.

**Kansas project.** The Kansas project was started with Category-I healer sealer work on Structure No. 50 at Osage County. Instead of sand blasting, shot blasting was used to clean the bridge surface. A 16-in.- (406-mm-) wide 65-HP shot-blasting machine was used. Figure 71 shows a shot-blasting machine. For Category I, blasting was performed at a speed of 50 ft/min. It took about 1 hr for the preparation of the bridge. In Kansas, each supplier was given 800 ft<sup>2</sup> for repair. All suppliers' areas were kept on the driving lane, and the passing lane was kept as the control area. In addition, an area of about 200 ft<sup>2</sup> was kept between the different suppliers. Similar to the other projects, Black Beauty aggregate was used in this project. However, the quality of the aggregate was not very good; it had excessive fines. Figure 72 shows the finished Category-I bridge.

Structure No. 114 at Shawnee County was selected for Category-II overlay. The shot blasting was performed at 20 ft/min. A deeper cleaning was required for Category II overlay. The shot blasting provided a very good surface preparation. Each material supplier was given 200 ft<sup>2</sup> of Category-II overlay to perform. All three material suppliers' areas were kept on one side of the bridge and were separated by control areas.

Structure No. 110 in Shawnee County was selected for the injection operation. As mentioned previously, all these bridges were slab bridge systems, so the deck thicknesses were very high. However, the delaminations

were restricted to the top portion of the decks. Therefore, the injection hole depths were kept at 3.5 in. A new injection process called gang porting was used for injection where four to five ports were connected at the same time from the injection-equipment reservoir. This method of injecting worked well. Flow valves were placed at each port to detect movement of material. If a certain port was not taking any material, the valve was closed for that port. New electronic equipment was attached with transducers to monitor the maximum/minimum pressure at the nozzle so the injection equipment could be shut down if the pressure had exceeded the limit. The initial pressure was set at 60 psi when the ports were taking material. Once the ports stopped taking material, the pressure was dropped to 30 psi and kept for 1 to 1.5 min.

One material supplier was given the driving lane for injection, and the other two suppliers divided the passing lane for injection.

### **Project monitoring**

Of the three demonstration projects, Michigan was the oldest. Several cores were obtained from these repaired bridges at different time intervals. These cores were evaluated with different laboratory test procedures. The results of these tests are described later.

### **Conclusions**

The effectiveness of the materials was evaluated through field and laboratory testing with results incorporated into the expert system. The three demonstration projects provided a gradual trend towards the perfection of this repair technique. During these field applications, various new techniques were tried, especially in the preparation of the bridge decks, application, and injection of materials. The lessons learned from Michigan, Mississippi, and Kansas were incorporated into the final expert system as a final product of the research effort. Overall, this repair technique showed potential to be an effective means of restoring and maintaining a concrete bridge deck in a cost-effective manner.

## **Laboratory Analysis of Demonstration Projects**

### **Projects (deck cores)**

A number of cores were selected for testing from the bridge decks in Michigan, Mississippi, and Kansas, where the demonstration projects were performed. These cores were actually removed from the bridge decks by the State DOTs and sent to the University and Nebraska-Lincoln (Omaha Campus) and the USACE laboratories. A few tests were then performed at these two

laboratories to determine some of the physical characteristics of these concrete specimens with polymer overlay and/or injection.

At the University of Nebraska laboratory, these evaluations included tensile and permeability tests. A description of the tensile and permeability tests performed follows, along with figures of the testing apparatus and procedures for these two types of tests. In addition to the tests performed at the University of Nebraska laboratory, other nondestructive tests were performed by the USACE at the Missouri River Laboratory. These tests were conducted on 4-in.-diam bridge-deck core samples that were provided by the Michigan and Mississippi DOTs.

Petrographic examination of the subject concrete core samples from selected bridge decks submitted by the Michigan and Mississippi DOTs indicates that the degree of concrete delamination and depth of deterioration are variable. Deterioration was more pronounced in Mississippi bridge-deck cores and occurred as surface popouts, scaling, and delamination with the formation of near-surface fractures oriented subparallel to the core top surfaces (former bridge-deck surface) and microcracking of the concrete paste generated by expansive distress due primarily to freezing-and-thawing action and steel-reinforcing-bar corrosion. The presence of shrinkages cracks increased the concrete permeability to moisture, chemicals, and gases, making the concrete more susceptible to freezing-and-thawing damage and promoting further steel-reinforcement corrosion. Bridge-deck cores from Michigan showed less deterioration, although near-surface fractures oriented subparallel to the core tops (former bridge-deck surface) and microcracking of the concrete paste have been generated by expansive distress due primarily to alkali-silica reactivity (ASR) and steel-reinforcing-bar corrosion. Treatment with various types of polymer flood-coat and injected materials to impregnate and bond existing fractures appears to have performed well, based on the majority of injected cores examined. The injection material uniformly penetrated the bridge deck wearing surfaces, although penetration depths were limited to approximately 2 in. and poor bonding was associated with only occasional fracture surfaces containing trapped air.

### **Tensile testing**

The cores selected for tensile testing included both the Category-II and the polymer-injection cores provided by the Michigan, Mississippi, and Kansas DOTs. Preparation for this testing involved cutting the core ends with a masonry saw so that only flat, smooth surfaces remained. At this point, steel plates were adhered to these ends with REZI-WELD 1000, a two-part epoxy mix. These plates were positioned at these ends so that the nut welded onto these plates lined up with the center of the cylinders. This procedure helped to ensure that concentric loading would occur and that the specimens would be in pure tension across their entire cross section when loading was applied.

Figure 73 illustrates these prepared specimens. A curing time of approximately

24 hr was permitted for the REZI-WELD 1000 in order to obtain the maximum possible tensile capacity of this epoxy. By doing this, a bond was created between the steel plates and concrete that would actually be stronger than the tensile strength of the concrete cylinders themselves.

After these preparation steps were performed, the cores were ready for testing. One end of a steel bar was turned into the nut located on each of the steel plates. The remaining end of these bars was then connected to the testing apparatus. Figure 74 shows an example of one of these prepared specimens in the testing apparatus. The specimens were then incrementally loaded in tension until failure occurred. This failure was typically away from the injection locations and polymer-coated surfaces and occurred through the concrete itself. For these specimens, it was concluded that the polymer injection or overlay coating was actually stronger than the cross section of the concrete itself in tension. Figure 75 shows one of these specimens after testing that failed in tension through the concrete. The results for all of the tensile tests that were performed on these cores are presented in Tables 22 through 25.

### **Permeability test**

Category-I and -II cores with polymer overlay were considered for this test. Here, each of the cylinders was cut so that two 1-in. specimens were obtained; one of these had the overlay coating, and the other one did not. The specimen with no overlay was considered the control sample for this test. A permeability cup or petri dish with water was then adhered to these specimens in a manner that allowed the water to permeate through the polymer overlay and the 1-in. thickness of the concrete or simply through the 1-in. thickness of concrete for the control sample. These specimens were then individually placed inside separate desiccators so that a condition of 100-percent humidity existed on one side of the specimen (the side with the cup and water attached) while 0-percent humidity existed around the specimen due to the presence of the desiccant. See Figure 76 for the specimen inside the desiccator. These desiccators with their specimens were then placed inside a temperature control box where a constant temperature of  $25^{\circ} + 1^{\circ}\text{C}$  was maintained. Figure 77 shows the temperature control box. The specimens were then removed from the temperature control box and the desiccators at 24-hr intervals and weighed in order to determine their corresponding water losses. The specimen weights were then plotted as a function of time, and these data points were then curve fitted with a first-order equation. The slope of this line was then taken as the rate that permeability was occurring through the 1-in. thickness of concrete or through the polymer overlay and concrete together. These slopes for the test specimens with polymer overlay were then compared with the slopes of their corresponding control specimens in order to determine the difference that the overlay made in allowing water to permeate through the specimens. It was typical for the permeability rates of the polymer-overlaid specimens to be 60 to 90 percent less than that of the control specimens with no overlay. The graph in Figure 78 is of the specimen with overlay and has a permeability rate of 0.0092 g/hr, and

the second graph (Figure 79) shows the permeability rate of the specimen with no overlay, which was 0.035 g/hr. In this case, the permeability rate was approximately 73 percent less for the specimen with the polymer overlay. Table 26 lists the permeability rates of the other test specimens.

<b>Table 22</b>					
<b>Mississippi Tensile Testing for Category-II and Injection Cores (First Batch)</b>					
<b>ID No.</b>	<b>Category</b>	<b>Type</b>	<b>Failure Load, lb</b>	<b>Stress, psi</b>	<b>Failure Description</b>
U-1-TRB SH	II	Unitex	2,950	230	Failure @ both interfaces, plates held some of overlay and concrete
S-R-TRB SH	II	Sika	2,275	180	Failure @ end w/o overlay, some concrete was taken with plate
T-1-TRB SH	II	Transpo	3,800	300	Failure @ end w/o overlay
H-3-TRB SH	II	Harris	1,600	130	Failure in concrete @ 3/4 in. under overlay
T-5-IM	Injection	Transpo	1,000	80	Failure @ middle of cylinder away from injection
S-3-IM	Injection	Sika	2,000	160	Failure in concrete just above overlay
U-2-IM	Injection	Unitex	450	40	Failure was a crack @ 1 in. from plate
4B			500	40	Failure @ middle of cylinder, through some of the aggregate
C4			2,150	170	Failure @ approx. 1/4 to 1/2 in. below top of specimen
H-4-TRB	II		2,675	210	Failure @ end w/o overlay, concrete was mostly taken with the plate
T-1-B			3,300	260	Failure @ 1/4 to 3/4 in. below the top of specimen
T-7-2			1,900	150	Failure @ 0 to 1/2 in. from top of specimen
U-2-TRB	II		2,750	220	Failure @ plate, some concrete was taken with it
S-1-IM	Injection	Sika	1,450	120	Failure @ 1/8 to 1/2 in. from bottom of specimen, failure around aggregate
S-3-TRB	II		2,600	210	Failure @ 1/4 to 3/4 in. below black overlay
2-3			500	40	Failure @ 1/2 to 3/4 in. above bottom of specimen

**Table 23  
Mississippi Tensile Testing for Category-II Cores (Second Batch)**

ID No.	Category	Type	Failure Load, lb	Stress, psi	Failure Description
TRB-U-1	II	Unitex	2,750	220	Failure @ 1/8 in. from end w/o overlay
TRB-H1-II	II	Haris	2,850	230	Failure @ 3/4 in. from end w/o overlay
TRB-T3-II	II	Transpo	3,650	290	Failure @ end w/o overlay
TRB-H3-II	II	Harris	3,100	250	Failure @ end w/o overlay
TRB-H2-II	II	Harris	3,550	280	Failure @ 3/4 in. from end w/o overlay
TRB-U3-II	II	Unitex	3,250	260	Failure @ 1 in. from end w/o overlay

**Table 24  
Kansas Tensile Testing for Category-II and Injection Cores (First Batch)**

ID No.	Category	Type	Failure Load, lb	Stress, psi	Failure Description
SH 114#3	II	Sikadur	2,200	180	Failure @ end w/o overlay
SH 114#24	II	Unitex	2,500	200	Failure @ end w/o overlay
SH 114#17	II	Unitex	2,450	200	Failure @ end w/o overlay
SH 114#7	II	Sikadur	2,200	180	Failure @ end w/o overlay
SH 114#4	II	Sikadur	2,700	220	Failure @ end w/o overlay
SH 114#5	II	Sikadur	2,725	220	Failure @ end w/o overlay
SH 114#14	II	Transpo	2,525	200	Failure @ end w/o overlay
SH 114#2	II	Sikadur	2,600	210	Failure @ end w/o overlay
SH 114#8	II	Sikadur	3,050	240	Failure @ end w/o overlay
SH 114#1	II	Sikadur	2,700	220	Failure @ end w/o overlay
SH 114#23	II	Unitex	2,250	180	Failure @ end w/o overlay
SH 110#24	Injection	Sika	2,000	160	Failure @ end w/o overlay
SH 110#15	Injection	Unitex	2,600	210	Failure @ end w/o overlay
SH 110#16	Injection	Unitex	1,400	110	Failure in concrete just under overlay
SH 110#19	Injection	Unitex	2,650	210	Failure @ end away from injection
Sh 110#13	Injection	Unitex	3,000	240	Failure @ end away from injection

## Results of evaluation of bridge-deck cores at USACE laboratory

The test methods employed were performed in accordance with the following bridge-deck treatment categories:

- a. *Pretreatment cores.* The subject concrete core samples (4-in. diameter) were examined to document the as-received condition of the samples, to determine concrete composition and general condition, and to select zones for further analysis. Test specimens were examined with powder X-ray diffraction (PXRD), stereo-polarized light (PLM), scanning electron microscope (SEM/EDX), and X-ray fluorescence (XRF) instrumentation using powder mounts and thin-section techniques in accordance with CRD-C 57 (ASTM C 856), CRD-C 127 (ASTM C 295), CRD-C 139 (ASTM C 294). Sample dimensional measurements were taken and unique features were recorded. Representative slab sections were cut perpendicular to the weathered sample top surfaces (concrete free-face), parallel to the core axes. Selected cut surfaces were subjected to the phenolphthalein test to determine the extent of concrete paste carbonation, which was confirmed by thin-section analysis. The concrete weathered surfaces and test specimens were examined using low-power stereo-light microscopy to identify the presence of secondary precipitate, reaction product, fractures, and other forms of distress. Random powder mounts were analyzed by X-ray diffraction to determine bulk mineralogy of the surface concrete. The preparations were scanned with a GE 500 X-ray diffractometer interfaced with a Siemens D-500 automation system, using monochromatic CuK alpha x-radiation, with an Ni filter and at a stepping rate of 2 deg per two-theta per minute. All external instrumental variables were not altered to increase precision and reduce experimental error.

ID No.	Category	Type	Failure Load, lb	Stress, psi	Failure Description
S35-25132 6B	Injection	Unitex	2,050	160	Failure @ ½ in. from end near injection
S35-25132 C-5A	Injection	Transpo	2,400	190	Failure @ end w/o overlay
S35-25132 5B	Injection	Transpo	2,400	190	Failure @ end opposite of injection
S35-25132 7B	Injection	Unitex	2,200	180	Failure @ ½ to 1 in. from end
S35-25132 C-1B	Injection	Sika	2,650	210	—
S35-25132 C-9A	Injection	Unitex	1,075	90	Failure @ ½ in. below top of specimen, around aggregate

<b>Specimen</b>	<b>Permeability Loss Rate ( g/hr)</b>	<b>R<sup>2</sup></b>
SH 144 #9 (w/o) <sup>1</sup>	0.0405	0.9887
SH 144 #9 (w)	0.0376	0.9604
TRB-S2-II (w/o)	0.035	0.9977
TRB-S2-II (w)	0.0092	0.9893
SH 114 #6 (w/o)	0.0316	0.9966
SH 114 #6 (w)	0.0093	0.9941
TRB-U2-II (w/o)	0.0297	0.9831
TRB-U2-II (w)	0.0073	0.9900
TRB-TI-II (w/o)	0.0389	0.9856
TRB-TI-II (w)	0.0075	0.9945
SH 114 #18 (w/o)	0.0829	0.9883
SH 114 #18 (w)	0.0076	0.9904
TRB-S3-I (w/o)	0.0487	0.9970
TRB-S3-I (w)	0.0081	0.9950
TRB-TI-I (w/o)	0.0391	0.9964
TRB-TI-I (w)	0.0309	0.9871

<sup>1</sup> w/o = without overlay; w = with overlay; R<sup>2</sup> = linear curve fit.

b. *Postinjection cores.* The subject core samples were initially mapped by stereo-microscopic examination to identify and characterize existing open cracks, which were traced with black ink to delineate crack features and fracture system morphology. To further characterize and evaluate the efficacy of the polymer treatment and injected fracture distribution, the entire core surfaces were examined using fluorescent light microscopy to differentiate fractures sealed with polymer material from fractures receiving no polymer material. Each fracture was classified and traced using color-coding to differentiate fracture types (red-polymer injected fractures, black-fractures containing no polymer cement). After fracture classification, the maximum depth of polymer impregnation was determined for each core, and each fracture length was measured and recorded with a planimeter and by image analysis. After tensile strength testing, the failure plane and polymer bond surfaces were evaluated using stereo- and petrographic-microscope and image-analysis instrumentation techniques in accordance with CRD-C 57 (WES 1949a), CRD-C 127 (WES 1949b), CRD-C 139 (WES 1949c).

c. *Posttreatment cores — Category-I, sealer-healer surface application method.* These cores were subjected to stereo-microscopic examination using ultraviolet light illumination to evaluate polymer flood-coat

penetration rates. Surface flood-coat layer thickness and depth of polymer absorption or penetration into the concrete surface were determined.

- d. *Posttreatment cores — Category-II surface coat application.* These cores were subjected to stereo-microscopic examination using ultraviolet light illumination to evaluate polymer-overlay penetration rates. Surface polymer-overlay layer thickness and depth of polymer absorption or penetration into the concrete surface were determined.

**Test results.** Results of the petrographic examination of the subject concrete core samples to determine concrete composition and polymer treatment efficacy are presented in Appendix J.

## Cost-Analysis for Injection/Sealing

Several factors affect the costs associated with the method of injecting delaminations in concrete bridge decks and then sealing or surface coating the entire deck area to seal out moisture. This research project did not attempt to determine costs for other methods of deck repair, but the literature search did produce approximate costs for bridge-deck replacement and traditional concrete overlays. Those costs were used to compare with approximate costs for injecting/sealing concrete decks as determined by this research project. As in any economic analysis, assumptions are made about present and future costs. The following list contains the assumptions for this project on which Table 27 is based.

### Cost-analysis assumptions

- a. The injection operation includes mechanized drilling (not hand drills), porting, mechanized injection, materials, cleanup, and a contractor bidding on a square-foot-unit price basis with a mobilization-demobilization charge allowed.
- b. *The sealing (Category-I) operation includes surface preparation (shot blasting recommended, but high-quality single-pass sand blasting is acceptable), materials, hand distribution of materials (polymer + aggregate) in one application, cleanup, and a contractor bidding on a square-foot-unit price basis.*
- c. The surface-coating (Category-II) operation includes surface preparation (shot blasting), materials, hand distribution in two applications of materials (polymer + aggregate), cleanup, and a contractor bidding on a square-foot-unit price basis.

- d. Average economic life expectancy and cost per square foot of operations are as follows:

<u>Option</u>	<u>Cost/ft<sup>2</sup> (\$)</u>	<u>Life (years)</u>
Deck replacement	31.00	20
Deck overlay (low-slump, low-cost concrete)	15.00	5
Deck overlay (latex-modified, high-cost concrete)	28.00	10
Injection of delaminations	38.00	5
Sealer healer, Category I	3.33	5
Surface coating, Category II	5.56	10

- (1) The deck to be repaired should have been rain free for 1 day previous to the application and should be surface dry.
- (2) The percentage amount or level of the delaminations at the beginning and end of the life expectancy should be the same.
- (3) The amount of time the bridge deck will not be in operation and the associated cost are not included in the cost analysis. It will vary by state, the location of the bridge, and other factors. However, the injection/sealing operations usually close only one lane at a time and for 1 to 2 days. The savings could be substantial.
- (4) Cost to repair potholes per year is assumed to be equal for all methods of repair; therefore, maintenance cost is not included in the analysis.
- (5) The life expectancy of the injection, Category-I, and Category-II operations are conservative by a factor of 2 or more. The research laboratory test results indicate a much longer life expectancy may be possible.
- (6) A Mississippi bridge deck (32.5 ft wide by 158 ft long) used in the research field tests was selected for comparing costs for the different repair techniques.
- (7) A 30-percent delamination area amount is the maximum assumed value before deck replacement should be considered.
- (8) The rate at which a deck delaminates is known as the delamination rate (DR) and has many variables not investigated by this research project. The DR can determine which repair technique should be considered. An average DR would be 1.5 percent/year or lower (30 percent/20 years). A high DR would be greater than 1.5 percent/year.

<b>Table 27 Annualized Cost Results</b>				
<b>Case or Situation</b>	<b>\$ per ft<sup>2</sup></b>	<b>Initial Cost (\$1,000)</b>	<b>Annual Cost (\$1,000) (N = 20 years)</b>	<b>Life Cycle (years)</b>
Case 1 Deck Replacement	31.00	160.0	17.5	20
Case 2A Overlay, Low Cost	15.00	77.0	23.3	5
Case 2B Overlay, High Cost	28.00	144.0	24.8	10
Case 3A Injection + Cat. I Sealer Healer Delaminations = 30 percent	38.00 3.33	76.0	23.0	5
Case 3B Injection + Cat. I Sealer Healer Delaminations = 15 percent	38.00 3.33	47.0	14.2	5
Case 3C Injection + Cat. I Sealer Healer Delaminations = 5 percent	38.00 3.33	26.9	8.1	5
Case 4A Injection + Cat. II Surface Coating Delaminations = 30 percent	38.00 5.56	87.0	22.5	5 10
Case 4B Injection + Cat. II Surface Coating Delaminations = 15 percent	38.00 5.56	57.8	13.7	5 10
Case 4C Injection + Cat. II Surface Coating Delaminations = 5 percent	38.00 5.56	38.3	7.9	5 10

- (9) All present values were inflated by 0.25 percent per month for life expectancies to future values. The future values were changed to present values, and an annualized cost was determined over 20 years using an annual interest rate or rate of return of 9.0 percent.

#### **Explanation of cases for cost evaluation**

- a. *Case 1 — deck replacement.* An annualized cost was determined based on an initial present value of \$160,000 ( $5,135 \text{ ft}^2 \times \$31/\text{ft}^2$ ).
- b. *Case 2A — overlay Type 1.* An annualized cost was determined based on an initial present value of \$77,000 ( $5,135 \text{ ft}^2 \times \$15/\text{ft}^2$ ). The present value of \$77,000 was inflated at 5-year intervals to 20 years for inflation effects. This Type 1 overlay is considered low-cost, low-slump concrete.

- c. *Case 2B — overlay Type 2.* An annualized cost was determined based on an initial present value of \$144,000 ( $5,135 \text{ ft}^2 \times \$28/\text{ft}^2$ ). The present value of \$144,000 was inflated at 10-year intervals to 20 years for inflation effects.

This Type-2 overlay is considered high-cost, latex-modified concrete.

- d. *Case 3A — injection/sealer-healer Category I.* The delamination percentage was assumed to be 30 percent. An annualized cost was determined based on an initial present value of \$76,000 ( $5,135 \text{ ft}^2 \times 30 \text{ percent} \times \$38/\text{ft}^2 + 5,135 \text{ ft}^2 \times \$3.33/\text{ft}^2$ ). The present value of \$76,000 was inflated at 5-year intervals to 20 years for inflation effects.
- e. *Case 3B — injection/sealer-healer Category I.* The delamination percentage was assumed to be 15 percent. An annualized cost was determined based on an initial present value of \$47,000 ( $5,135 \text{ ft}^2 \times 15 \text{ percent} \times \$38/\text{ft}^2 + 5,135 \text{ ft}^2 \times \$3.33/\text{ft}^2$ ). The present value of \$47,000 was inflated at 5-year intervals to 20 years for inflation effects.
- f. *Case 3C — injection/sealer-healer Category I.* The delamination percentage was assumed to be 5 percent. An annualized cost was determined based on an initial present value of \$26,900 ( $5,135 \text{ ft}^2 \times 5 \text{ percent} \times \$38/\text{ft}^2 + 5,135 \text{ ft}^2 \times \$3.33/\text{ft}^2$ ). The present value of \$26,900 was inflated at 5-year intervals to 20 years for inflation effects.
- g. *Case 4A — injection/surface coating Category II.* The delamination percentage was assumed to be 30 percent. An annualized cost was determined based on an initial present value of \$87,000 ( $5,135 \text{ ft}^2 \times 30 \text{ percent} \times \$38/\text{ft}^2 + 5,135 \text{ ft}^2 \times \$5.56/\text{ft}^2$ ). The present value for injection was inflated at 5-year intervals to 20 years for inflation effects. The present values of Category 2 was inflated at 10-year intervals to 20 years for inflation effects.
- h. *Case 4B — injection/surface-coating Category II.* The delamination percentage was assumed to be 15 percent. An annualized cost was determined based on an initial present value of \$57,800 ( $5,135 \text{ ft}^2 \times 15 \text{ percent} \times \$38/\text{ft}^2 + 5,135 \text{ ft}^2 \times \$5.56/\text{ft}^2$ ). The present value for injection was inflated at 5-year intervals to 20 years for inflation effects. The present values of Category 2 was inflated at 10-year intervals to 20 years for inflation effects.
- i. *Case 4C — injection/surface-coating Category II.* The delamination percentage was assumed to be 5 percent. An annualized cost was determined based on an initial present value of \$38,300 ( $5,135 \text{ ft}^2 \times 5 \text{ percent} \times \$38/\text{ft}^2 + 5,135 \text{ ft}^2 \times \$5.56/\text{ft}^2$ ). The present value for

injection was inflated at 5-year intervals to 20 years for inflation effects. The present values of Category 2 was inflated at 10-year intervals to 20 years for inflation effects.

### **Conclusions from cost analysis**

When the bridge deck is injected and sealed (Category I or II) at a delamination area less than 15 percent, the annualized cost should remain significantly lower than the other two repair methods. The annualized cost for injection and sealing is significantly lower for delamination areas of 5 percent.

The annualized costs for Category-II surface coatings, for the same delamination areas, are generally lower than for Category I. Category-II systems are normally used, as are overlays, where a new wearing surface is required in addition to the deck-sealing capabilities.

When the bridge-deck area of delaminations is at the maximum of 30 percent, the annualized costs are in the range of overlays, with deck-replacement annualized costs about 30 percent lower. However, the large amount of initial dollars may not be available to a bridge owner for deck replacement or the more expensive versions of overlays. When bridge downtime is considered, deck replacement and overlays are at a disadvantage to injection/sealing operations. When delamination rates are high, injection/sealing operations can defer the use of high initial cost operations, regardless of the percentage of the delamination area.

The lowest annualized cost-repair technique of those considered depends upon the condition of the bridge. The smaller the area of delaminations, the lower the annualized cost. If the delamination area is around 5 percent, the injection/sealing or injection/surface-coating operations could be 50 percent less in annualized costs compared to its nearest rival. Therefore, a regular 5-year maintenance plan using the injection/sealing operation, when no more than 5 percent of the deck area is delaminated, can provide relief to bridge owners who wish to defer high initial expenditures or who wish to use a low annualized cost operation.

## **Knowledge-Based Expert System for PORT System**

Knowledge-based expert systems (KBES) can be used to accurately and quickly evaluate existing bridge decks, advise, and recommend the most suitable rehabilitation process. The KBES will allow bridge maintenance personnel to determine the best solution and most appropriate procedure by accessing the expert knowledge built into the computer system. The KBES is an interactive computer system that reasons with rules of thumb and facts

supplied by the bridge experts and this research. The name of this expert system is Concrete Bridge Deck Repair Advisor (DRAD).

The KBES is unlike traditional computer software because it can reason much like human beings do, with incomplete facts, certainty factors, and confidence limits. An expert system is generally defined as a computer system that can perform at or near a human level. It can sometimes exceed the competence of any one individual. It contrasts with the traditional computer approach to problem solving that is based on the use of algorithms — a set of finite steps involving repetition of some operation. This expert system uses heuristic knowledge, defined as rules-of-thumb or simplifications used by experts. An expert is defined as the person or persons responsible for expert advice who must apply heuristic rules to formulating the correct diagnostic or troubleshooting solution and the best procedure for correcting the problem at the bridge site. The experts for this research were the industry research participants (see Appendix C). However, no warranty of any kind is provided to the user of DRAD.

DRAD is a very user-friendly and low-cost advisor that is tireless and never on vacation. It can be updated easily by non-computer-oriented experts with the development software. When security is important, run-only systems are available to the user. It can grow with the bridge owner's specific applications and changing conditions, all without a resident computer guru. The methods and heuristic knowledge that has accumulated over the years can be contained in a single intelligent system like DRAD.

The development of DRAD was conducted in two stages: (a) development of the prototype system using data from the literature search and survey and (b) development of a complete PC-based expert system after all field and laboratory data were analyzed. The State DOT and industry partners provided the facts and relationships that are important to the decision tree in DRAD. The decision tree can be modified by each user if Level 5 development software is purchased. The research project's version is a run-only, Version 1.2, and is available on a CD-ROM. The industry participant, Level 5, Information Builders, Inc., should be contacted for details concerning the development software and further distribution of the software. The KBES, with the help of the expert knowledge, analyzes the field data and makes recommendations for the (a) best rehabilitation procedure to use; (b) cost factors and parameters; (c) best approach for cleaning the deck, drilling, and injecting the polymer; (d) information relative to determining where the delaminations are located; (e) laboratory- and field-demonstration data; and (f) references. DRAD contains most of the data, information, and photographs for the research project found in this report.

The KBES software uses readily available and inexpensive software packages. The two software packages needed are: (a) Level 5 Professional Expert System and (b) Windows Version 95 or higher. As the KBES grows in size, compatible database systems could be used in combination with Level 5

software. The computer hardware recommended to run the software is an IBM PC-compatible pentium processor (the faster, the better), a quality color monitor, a large hard drive, a fast CD-ROM drive, and 32-meg RAM memory. Many laptops are available that meet this recommendation.

The following research objectives for the KBES were met:

- a.* To build a PC-based KBES with expansion capabilities using a module design so that the first module would be the polymer-injection process module.
- b.* To identify the criteria and procedures used by the bridge experts to solve problems encountered by field personnel in determining the best procedure and method for bridge rehabilitation.
- c.* To convert those criteria and procedures to a rule format suitable for a KBES shell.
- d.* To validate and test the prototype system with the primary experts.

# 4 Conclusions and Recommendations

---

## SUPERSCANNER

### Conclusions

Although the SUPERSCANNER was designed specifically for detecting delaminations in bridge decks, the system can also be used as is or easily modified to work for other types of concrete structures. This system has the potential to advance the state of the art of quality-control and quality-assurance measurements for concrete for the construction industry. Advancements were made in a number of areas.

The transducers were improved significantly. The design and implementation of an angled faceplate resulted in a stronger primary wave (2P) echo than the parallel faceplate of the older system because the highest intensity rays from the transmitter were now directed toward the receiving transducer. The materials (piezo ceramic, glass, and granite rock) that made up the faceplate of the new system were matched in their acoustic impedance with each other and with concrete, which produced a stronger 2P echo than the previous UPE system. As noted in Chapter 2, improvement in the signal quality was considered the main priority ahead of any other development feature.

Improvements were made in understanding how to interpret events in the composite signal. The ray-based model (RBM) is a useful software tool for identifying various events in the composite pulse-echo signal. The RBM permits the identification and hence the rejection of the unwanted mode-converted waves and those waves that have undergone multiple reflections. The use of high-quality concrete and rock models with known geometries and mechanical properties made it possible to more accurately label the events produced by mode conversion and multiple reflections. A store of concrete specimens with known geometries and properties was created and represents a good start for an ultrasonic laboratory for testing pulse-echo systems.

A significant advancement was made when the rolling pond was developed. A moving layer of water between the transducer and the concrete replaced the slow process of smearing grease onto the concrete surface to make measurements. The development of the rolling pond represented a quantum jump (approximately 700X) in the speed of data acquisition, a previously known limitation with the original UPE technique. Although the rolling pond is heavy, about 400 lb, with the proper equipment for transporting and making the measurements, it should not prove to be an obstacle to rapid measurements. Water represents an ideal ultrasonic couplant fluid for bridge decks, although it may require the addition of some additive, ethylene glycol, salt, etc., for winter measurements to prevent freezing.

The SSP algorithm was shown to be useful for concrete, a large-grain material. Results indicated that material noise could be reduced. Currently, the SSP algorithm is not being used for onsite analysis by WES personnel for several reasons: first, the computation requires a computer with considerable memory and speed to give results in a short time, and second, the technique is not currently critical to the operation as the large area of the new receiving transducer tends to average out scattering noise from large particles while keeping the flaw echo present. All points on the transducer surface receive the flaw echo almost at the same instant, causing building of the signal, unlike scattering from aggregate, which tends to cancel out.

The transformation of hundreds of signals into a graphic presentation added meaning to the data. One can receive almost instant understanding of the depth and location of the delaminations in the bridge deck without much training and without having to struggle to interpret the cumulative meaning of hundreds of individual signals. Although the current system does not produce graphics in real time, that is possible with the purchase of the proper computer and software.

ANNs can mean a significant improvement in UPE measurements by replacing the expert, who is trained to recognize certain signal patterns, with computer intelligence. ANNs are known to be valuable in discriminating among complex signal patterns, and WES researchers have shown that ANNs can discriminate to the extent that they can recognize the difference in degree of microcracking in concrete.

Preliminary results indicate that at least three signal-processing techniques are useful for processing UPE signals. (a) The SSP routines were able to successfully reduce the influence of backscattering from the aggregate matrix interfaces, permitting backwall surfaces to be detected more plainly; (b) the RBM has been shown to be capable of detecting 2P, 2S, PS, and 4P echoes from the backwalls of concrete specimens having thicknesses from 2 to 8 in.; and (3) the ANN model was able to rank six concrete specimens that had differing degrees of microcracking in the correct order of deterioration.

Although benefits were seen for reducing material noise when techniques such as polarity thresholding with minimization were implemented with the SSP algorithm, an increase in the area of the receiving transducer, which improves spatial averaging, has somewhat diminished the need for the SSP algorithm, a technique for improving the SNR. The SSP enhances computer interpretation, and the amount of the data is greatly reduced.

Significant improvements were made in the development of the new UPE system, and it appears that the system can compete against any of the current technologies used to detect delaminations in concrete.

The UPE system was not developed into a compact field package as stated in the CPAR-CRDA objective. It was the primary purpose of WES as a research organization to incorporate the intrinsic features into the system that would allow the UPE system to function properly and leave the market aspects to the manufacturer. It would have been unnecessary and wasteful for WES to attempt to shrink the measurement system into a compact field package as the organization that manufactures the apparatus for sale will have had their own ideas about what extrinsic features to incorporate into the system to make it more attractive to the public. Features such as size, weight, cost, etc., are best dealt with after the research phase is successful and complete. The funds were barely sufficient for completing the research, besides pursuing a commercial design that was likely to be refashioned by the manufacturer.

The deliverance of new technology in compact packages tends to be an iterative and evolutionary process. This has been true in the manufacturing industry for computers, NDE equipment, televisions, etc., largely because successive developers can better focus on those aspects of the invention that make the system more marketable. If WES would have expended its resources towards making the device compact and attractive, performance and basic design would have suffered. It should also be pointed out that this device was taken to the field many times in a standard minivan. There may be a size below which it is not practical to reduce the dimensions of the system further. The system as it currently exists may not be too far from that minimum size. Other pavement and bridge analyzers tend to be even larger than the ones produced here (i.e., falling weight deflectometer, etc.).

The goal was to get the UPE system as far along as possible in its research development so that the manufacturer would have to deal only with the commercial aspects of development and thereby provide an incentive for commercialization. During the course of the project development, WES personnel were in constant contact with a potential manufacturer, who was unwilling to commit funds to develop and commercialize the UPE system because of uncertainty as to whether it would compete against the current diagnostic technologies. Also, the manufacturer was not sure of the market demand for such a system and was not willing to invest a few hundred thousand dollars into manufacturing UPE systems for sale. Although the Corps provided a service by assuming some of the initial risks of development, it has

not been sufficient to guarantee commercialization. So far, the potential manufacturer has not been persuaded to commit the funds necessary to prepare the system for market.

It may be necessary for WES or someone else to promote the SUPER-SCANNER to the DOTs through another program over a period of a 2 or 3 years to survey the interest in using the device before a manufacturer is willing to step forward and commit the time and funds to manufacture and sell the system. Also, patent protection is a necessity before a manufacturer will commit significant funds to the process of manufacturing. WES was only recently notified (March 1998) that the fee for patent approval had been paid by the Corps and therefore that patent approval appeared guaranteed. This has taken almost 2 years, as the disclosure was first made in June 1996.

However, even though the UPE system may not currently exist in its smallest package, important advancements in the system were made that will now allow some commercializer to realize that objective with less effort.

Floppy disk storage and the latest in piezoelectric technology were employed in the new UPE system. The implementation of the ANN system and the KBES were not completed, nor was an on-board computer installed.

Cost savings cannot be given on the use of an UPE system until the final field prototypes are built.

## **Recommendations**

The UPE system has not been thoroughly tested for all types of field conditions. There are many types of cracking patterns in the field, and the signal patterns that correlate with these types are not currently known. ANN algorithms should be trained to recognize these cracking patterns, but before that, these cracking patterns need to be simulated in the laboratory so that DSP algorithms can be found that are sensitive to the signals from these cracking patterns.

Although the equipment development in this project was for diagnosing the condition of concrete bridge decks, the elements of UPE improvement can be applied to UPE systems that have a greater penetration capability. WES researchers are currently working on a system that has the potential for probing the interior of the larger dimensions of locks and dams. New developments such as the ability to input complex digital signals (real and imaginary numbers) to ANNs may add additional effectiveness when classifying UPE signals. Enhanced data reduction and classification techniques are available in the area of DSP and should be implemented for ANN inputs.

# PORT System

## Conclusions

The commercialization of the PORT system was complete.

As a result of this research, three new procedures were perfected to repair bridge decks. These procedures were (a) injection (subsurface delamination repair), (b) Category I (sealer healer), and (c) Category II (surface coating with new wearing surface). These procedures can be used individually or in combinations, such as injection and Category I or injection and Category II.

Three demonstration projects were performed with the help of three State DOTs (Michigan, Mississippi, and Kansas) to study the performance of this repair technique. In all of these demonstration projects, control areas were used to compare the effectiveness of the repair.

The laboratory and field data from this study indicate that the use of polymer materials can improve the overall strength and long-term durability of a conventional concrete bridge deck.

The service-life expectancy of the rehabilitation of any concrete structure (i.e. bridge decks, roadway pavement, navigation locks, buildings, gravity dams, etc.), for the most part, is dependent on, first, the level of distress in the structure at the time of the applied rehabilitation, and second, the magnitude of the generic rehabilitation scheme or technique. The level of the distress is site-specific and is a function of parameters such as type and severity of the attack mechanism or environment, initial quality of concrete and concrete constituents, severity of cracking and delaminations, level of debris and contaminants in the delaminations, quality of workmanship in the original construction, and finally, the response to applied load surcharges (service performance level). Since, in many cases, more than one generic rehabilitation scheme can be used, the rehabilitation process is not nearly so site-specific. Therefore, an engineered rehabilitation scheme chosen for a particular project should address the parameters of distress present so as to extend the life of the structure (which in many cases has fallen very short of the original life expectancy).

The application of a polymer-based rehabilitation scheme serves two basic functions. The polymer acts as a binder for concrete separations (both micro and macro) and tends to fill surface and below-surface void spaces of the concrete. The first function re-establishes the original structural integrity, and the second function seals the structure (concrete mass) against environmental attack mechanisms. The polymer itself, once it has set, will contribute its own life-expectancy parameters to the rehabilitation effectiveness (which in many areas exceed the life-expectancy parameters of the nondistressed concrete). Therefore, the structure will have been restored to its originally intended prestressed condition by these actions. Indications are that this rehabilitation

can be expected to produce a life that is near the original life expectancy, and this condition begins as soon as the rehabilitation is complete.

By comparison, any type of overlay rehabilitation will be no better than the overlay itself since, in order to be effective, the overlay must completely bridge over the distress; therefore, the surviving components of the distressed structure offer no contributions to the rehabilitation. However, with the polymer fix, the surviving parts are re-integrated into the life-cycle performance of the structure and do not have to be replaced, producing significant cost savings and extended performance life.

Results from the field test sections and controlled laboratory simulations revealed that the polymer-injection process of repairing subsurface delaminations shows considerable promise for being a viable option over other considerably more expensive repair methods, such as pavement removal/repair by overlay. The key factor to be considered in any type of repair is the reduction of moisture that infiltrates through the concrete mass. The injection of polymer material into delaminated areas followed by surface seal-coat applications (Category I, Category II) will greatly reduce the amount of water entering the concrete mass. It is felt that success can be obtained without 100 percent of the delaminated voids filled and without good bond development in all areas. If a delaminated area can be at least spot welded and voids can at least be filled if not bonded, the structural integrity of the pavement can be improved.

The method of drilling the injection holes is critical. If drilling causes excessive spalling or if the debris is not adequately removed during the drilling process, the flow of the polymer into the delamination can be restricted. Also, the holes need to be perpendicular to the surface for the injection ports to have a good seal. Laboratory tests showed that the holes drilled with an automatic drill system with a consistent feed pressure caused less spalling inside the delamination and were more perpendicular than the holes drilled by hand. It was also found that the rotary/impact electric drill was more effective than both the rotary-only drill and the drill that uses a hollow bit.

**Field application.** Concrete bridge decks in three states constructed with different concrete materials and mixtures and exposed to different climatic conditions were treated under the CPAR Program. Overlay applications, sealer-healer applications, and delamination-injection operations were performed. Following the particular field application, cores were obtained for laboratory analysis. Testing included tensile, permeability, and petrographic and image analysis.

Cores were taken following climatic cycles to better analyze durability as well as bond characteristics of the particular polymer materials. Extremely impressive results were obtained, as reported previously. The bottom line is that the concrete quality and durability were improved, and the concrete was protected.

**Laboratory simulation.** A more controlled laboratory-testing program was designed to supplement the field testing. Since the bridge-deck cores showed some areas of incomplete bond, seemingly due to the presence of moisture and/or debris in the delamination voids, it was felt that these were critical factors to model in the laboratory simulation. On small-scale laboratory tests, these factors (moisture and debris) seemed to have little to no effect on overall bond after complete injection of a relatively high-viscosity material. Concrete slabs, or sandwiches, were prepared, injected, and cored, as discussed previously. Testing included compression, tensile, flexural, freezing and thawing, and ultraviolet.

While compression, tension, and flexural tests were used to evaluate strength and structural properties of the polymer materials, freezing-and-thawing and ultraviolet tests were used to evaluate the durability of the materials.

Again, very impressive results were obtained in these tests. Test results on laboratory-prepared specimens support the findings of the field cores in that again concrete quality can be improved and protected from various attack mechanisms.

## **Recommendations**

The combination of injection pressure, polymer viscosity, temperature, and void thickness plays a major role in achieving a successful treatment. The debris and moisture did not appear to inhibit the materials in obtaining adequate bond. Based on research to date, use of a higher viscosity material (150 to 300 cps) in the larger voids and use of the lower viscosity material (10 to 20 cps) in the smaller voids and for surface-seal applications are recommended.

It is highly recommended that efforts be made to obtain a clean, dry deck prior to application of the polymer material. A sand blast, or even better a shot blast, cleaning operation followed by a dry vacuum is recommended.

A vital component in designing a rehabilitation program is definition and mapping of delaminations in concrete pavements. Proper placement and depth of injection ports are critical factors when using polymer injection as a means to rehabilitate a structure. The use of a simple chain-drag device will provide insight as to the presence of a delamination, but will not provide information as to depth, void thickness, or multiple delaminated levels. Additional tools such as coring, the pulse-echo device, impact devices, and cameras should be used in evaluating a pavement structure.

A further enhancement, the development of a non-glued system in lieu of a glued port system, would save time and money.

It is recommended that additional long-term laboratory testing be performed in the area of ultraviolet resistance of polymer materials.

## **Systems Combined**

Although the two subsystems (PORT and UPE system) can operate independent of each other, the performance of the two products as a system should be better than one subsystem used alone.

The UPE system is ready for commercialization but may require an extensive field study to explore the many types of deterioration and the signal features that correlate with that deterioration before the ANN algorithms can be fully trained, tested, and implemented. The time and effort needed for full UPE development were more than was possible with this project, but significant advancements have been made in creating a brand-new technology that will improve construction practices in the future.

To complete the two subsystems, a proposal for a thorough field-evaluation program needs to be pursued with FHWA to make the systems field worthy and to promote the systems for DOT organizations.

## 5 Commercialization and Technology Transfer Plan

---

The PORT system has been commercialized and is being marketed through two manufacturers, Liquid Control Corporation and EZ Drill, Inc. These manufacturers will provide technical services to end-users and will continue to further develop the system for broader application areas in the construction field. The University of Nebraska-Lincoln (UNL) personnel are involved with various concrete committees such as those in TRB, ASTM, and American Concrete Institute, and will continue to make presentations and articles about the new technology available to the private sector.

The products developed from this research will be marketed to public transportation agencies and related construction industries. National conference presentations and preparation of aids and specifications as part of this project will encourage immediate use of the results. Furthermore, the equipment, procedures, materials, and other applications of the project will be enhanced by training a selected number of personnel from industry, State, and Federal transportation agencies. Zevex, Inc., has an option to package the UPE system into an attractive portable field unit with an on-board computer that will perform in real-time. Information Builders, Inc., has an option to commercialize the KBES software related to the PORT system. Drilling equipment and vacuum attachments will be manufactured and marketed by EZ Drill, Inc. The PORT system will be marketed by Liquid Control Corporation.

WES is currently in the process of obtaining a patent for the SUPERSCANNER. If awarded, this patent should provide some investment protection and incentive for the manufacturer. Two companies are now trying to assess the market possibilities for the SUPERSCANNER. WES has introduced and will continue to introduce the new flaw-detection system to the USACE and other Federal agencies through a CPAR technical report, *The REMR Bulletin* (the newsletter of the Repair, Evaluation, Maintenance, and Rehabilitation Research Program), and other USACE publications.

A presentation was given at *The International Society for Optical Engineering* in June 1995, in Oakland, CA, on the SUPERSCANNER. An article was

published in the *Military Engineer*, Aug-Sep 95 issue, about the SUPERSCANNER. A paper on the SUPERSCANNER was presented at the June 1996 SEM Conference in Nashville, TN. A paper on the SUPERSCANNER was presented in January 1997 at the TRB annual meeting in Washington, DC. An article about the SUPERSCANNER was published in the *APWA Reporter*, July 1997 issue. At least three other presentations have been given at the yearly conferences held by UNL for the industry participants — in Kansas City, MO; in Clear Creek, CO; and in Omaha, NE.

UNL commercialization efforts have been directed toward cooperating with industry participants to fully evaluate the PORT system prior to market introduction. This evaluation focused on the interaction of the hydraulic and mechanical components of the drilling and injection equipment. The PORT system has been tested in-house by Liquid Control Corporation and EZ Drill, Inc., as well as in the field in numerous states. The SUPERSCANNER has been tested in the field on at least four different bridges.

As noted, the SUPERSCANNER is not ready for commercial use as the prototype system does not exist in a portable field package. Its performance has not been demonstrated sufficiently before interested parties such as DOT personnel, and the potential manufacturers are not yet ready to commit funds to make the system adaptable for the field. However, the research was successfully completed and a quasi-field prototype has been designed, constructed, and evaluated in the laboratory and field. It is likely that the current prototype for the SUPERSCANNER will require some modifications, as the field will introduce some new conditions and constraints on the equipment. Extensive field tests are required to determine the particular problems that may exist and to promote the technology, as most tests up to this point have all been in a laboratory setting. A 2- or 3-year FHWA project will be proposed to evaluate the new system in various field situations. Detailed plans for comparison field tests between the new SUPERSCANNER and the chain drag (also, radar) will be laid out in a proposal. State DOT personnel will be familiarized with the research findings and their approval received in the form of a letter to submit it as a topic for an FHWA project to demonstrate the utility of the subsystems for improving the evaluation and repair of concrete pavements.

The automation task (implementation of ANNs and EXPERT system) was not completed because more time was required to get the imperfections out of the transducer/rolling-pond system than had originally been expected. However, the automation process is not considered to be risky research, like the development of the transducer/rolling-pond system, but is considered to be a straightforward engineering task.

# References

---

- Al-Mandil, M.Y., Baluch, M.H., and Azad, A.K. (1990). "Categorization of damage to concrete bridge decks in Saudi Arabia," *J. of Performance of Constructed Facilities, American Society for Civil Engineers* 4(2), 100.
- Alexander, A.M., and Haskins, R.W. (1998). "Application of artificial neural networks to ultrasonic pulse-echo system for detecting microcracks in concrete," Technical Report REMR-CS-159 (in press), U.S. Army Engineer Waterways Experiment Station, Vicksburg, MS.
- Alexander, A.M., and Thornton, H.T. (1988 Mar). "Developments in ultrasonic pitch-catch and pulse-echo for measurements in concrete," *Nondestructive Testing, SP-112*, H. S. Lew, ed., American Concrete Institute, Detroit, MI, 21-40.
- Alexander, D.R., Grau, R.H., and Alexander, A.M. (1995). "Repairing ridges and roads," *The Military Engineer* 87(572), 22-24.
- American Association of State Highway and Transportation Officials. (1990a). "Standard specification for bearing capacity of soil for static load on spread footings," AASHTO T 235, Washington, DC.
- \_\_\_\_\_. (1990b). "Standard specification for testing epoxy resin adhesive," AASHTO T 237, Washington, DC.
- American Concrete Institute. (1962). "Guide for use of epoxy compounds with concrete," ACI Committee 403, *J. of the Amer. Concrete Inst.* 59, 1121-1142.
- \_\_\_\_\_. (1992). "Guide for the selection of polymer adhesives with concrete," ACI 503.5R, Farmington Hills, MI.
- American Society for Testing and Materials. (1996). *Annual book of ASTM standards*, West Conshohocken, PA.
- Designation C 39, "Compressive strength of cylindrical concrete specimens."

- Designation C 42, "Obtaining and testing drilled cores and sawed beams of concrete."
- Designation C 78, "Test method for flexural strength of concrete using simple beam with third point loading."
- Designation C 192, "Making and curing concrete test specimens in the laboratory."
- Designation C 215, "Fundamental transverse, longitudinal, and torsional frequencies of concrete specimens."
- Designation C 307, "Tensile strength of chemical-resistant mortar, grouts, and monolithic surfacings."
- Designation C 496, "Splitting tensile strength of cylindrical concrete specimens."
- Designation C 579, "Test methods for compressive strength of chemical-resistant mortars and monolithic surfacings."
- Designation C 580, "Flexural strength and modulus of elasticity of chemical-resistant mortars, grouts, monolithic surfacings, and polymer concretes."
- Designation C 597, "Pulse velocity through concrete."
- Designation C 666, "Test method for resistance of concrete to rapid freezing and thawing."
- Designation C 856, "Petrographic examination of hardened concrete."
- Designation C 866, "Filtration rate of ceramic whiteware clays."
- Designation C 881, "Epoxy-resin-base bonding systems for concrete."
- Designation C 882, "Bond strength of epoxy-resin systems used with concrete by slant shear."
- Designation C 883, "Standard test method for effective shrinkage of epoxy-resin systems used with concrete."
- Designation C 884, "Thermal compatibility between concrete and an epoxy-resin overlay."
- Designation C 928, "Packaged, dry, rapid-hardening cementitious materials for concrete repairs."

Designation C 294, "Constituents of natural mineral aggregates."

Designation C 295, "Petrographic examination of aggregates for concrete."

Designation D 93, "Flash-point by Pensky-Martens closed cup tester."

Designation D 570, "Water absorption of plastics."

Designation D 638, "Tensile properties of plastics."

Designation D 648, "Deflection temperature of plastics under flexural load."

Designation D 695, "Compressive properties of rigid plastics."

Designation D 732, "Shear strength of plastics by punch tool."

Designation D 790, "Flexural properties of unreinforced and reinforced plastics and electrical insulating materials."

Designation C 866, "Filtration rate of ceramic whiteware clays."

Designation D 1310, "Flash point and fire point of liquids by tag open-cup apparatus."

Designation D 1425, "Unevenness of textile strands using capacitance testing equipment."

Designation D 1525, "Vicat softening temperature of plastics."

Designation D 1544, "Color of transparent liquids (gardner color scale)."

Designation D 1824, "Apparent viscosity of plastisols and organosols at low shear rates."

Designation D 2240, "Rubber property-durometer hardness."

Designation D 2369, "Volatile content of coatings."

Designation D 2393, "Standard test method for viscosity of epoxy resins and related components."

Designation D 2471, "Gel time and peak exothermic temperature of reacting thermosetting resins."

Designation D 2566, "Test method for linear shrinkage of cured thermosetting casting resins during cure."

- Designation D 2849, "Method of testing urethane foam polyol raw materials."
- Designation D 4580, "Standard practice for measuring delaminations in concrete bridge decks by sounding."
- Designation E 274, "Skid resistance of paved surfaces using a full-scale tire."
- Aussel, J.D. (1990). "Split spectrum processing with finite impulse response filters of constant frequency-to-bandwidth ratio," *Ultrasonics* 28, 231.
- Babaei, K., and Hawkins, N.M. (1987 Sep). "Evaluation of bridge deck protective strategies," Transportation Research Record 297, Transportation Research Board, National Research Council.
- Bilgutay, N.M., Bencharit, U., Murthy, M., and Sanjie, J. (1990). "Analysis of a non-linear frequency diverse clutter suppression algorithm," *Ultrasonics* 28, 90-92.
- Bose, N.D. (1985). *Digital Filters: theory and applications*. North-Holland, New York.
- Calvo, L., and Meyers, M. (1991). "Overlay materials for bridge decks: polymer overlays are popular," *Concrete International: Design & Construction* 13(7), 46.
- Carter, P.D. (1989 Nov). "Preventive maintenance of concrete bridge decks," *Concrete International*, 33-36.
- Crumpton, C.F., et al. (1969). "Bridge Deck deterioration study," Part 8, "Special study of Blue Rapids Bridge Deck," State Highway Commission of Kansas, Kansas.
- Demuth, H., and Beale, M. (1992). "Neural network toolbox for use with MATLAB™, users guide," The MathWorks, Inc., Natick, MA.
- Dinitz, A.M., and Ferri, R. (1985). "Polymer concrete (MMA) application for bridge rehabilitation and construction," *National Bridge Conference, Pittsburgh, June 1-3, 1983*, Transport Industries, Inc., Pittsburgh.
- Downing, D., and Covington, M. (1989). *Dictionary of computer terms*. 2nd ed., Barron's Publishing Co., New York.
- Emmons, P.H., et al. (1993 Sep). "A rational approach to durable concrete repairs," *Concrete International*, American Concrete Institute, 40-45.

- Emmons, P.H., et al. (1994 Mar). "Concrete repair in the future turn of the century--any problems?" *Concrete International*, American Concrete Institute, 42-49.
- Fontana, J.J., et al. (1991). "State-of-the-art report on polymer-modified concrete," ACI 548.3R-91, reported by Committee 548, American Concrete Institute.
- Fowler, D.W. (1985). "Polymer concrete--uses, materials, and properties," ACI SP-89, American Concrete Institute.
- Furr, H.L. (1984 Oct). "Highway uses of epoxy with concrete," Transportation Research Record NCHRP 109, Transportation Research Board, National Research Council.
- Graf, Rudolf F. (1974-75). *Dictionary of Electronics*, Radio Shack, Tandy Corporation Company, Fort Worth, TX.
- Haskins, R.W., and Alexander, A.M. (1995). "Computer interpretation of ultrasonic pulse-echo signals for concrete dams," *The International Society for Optical Engineering, Proceedings of the Session on Nondestructive Evaluation of Aging Structures and Dams, Oakland, CA, June 7-8, 1995*, 182-194.
- Heiman, J.L., and Koerstz, P. (1991). "Performance of polymer-modified cementitious repair mortars in chloride contaminated concrete," *Transactions of the Institution of Engineers* 33(3), 169.
- Hewlett, P.C. (1993 Mar). "Assessment and evaluation of polymer-based repair materials," *Concrete International*, American Concrete Institute, 39-41.
- Hime, W.G. (1993 Oct). "The corrosion of steel--random thoughts and wishful thinking," *Concrete International*, American Concrete Institute, 54-57.
- \_\_\_\_\_. (1994 May). "Chloride-caused corrosion of steel in concrete: a new historical perspective," *Concrete International*, American Concrete Institute, 56-61.
- Holland, T.C. (1992 Mar). "Corrosion protection for reinforced concrete -- a summary of corrosion prevention strategies," *Concrete Construction*, 230-236.
- Hover, K. (1993 Jan). "Why is there air in concrete?" *Concrete Construction*.
- Jenkins, J.C., Beecroft, G.W., and Quinn, W.J. (1974). "Polymer concrete overlay test program," Report No. FHWA-RD-75-501, Interim Report, Federal Highway Administration, Washington, DC.

- Johnston, D. (1987 Jul). "High molecular weight methacrylate test section—Vivian Rest Area, July 14, 1987," South Dakota Department of Transportation Memorandum, Pierre, SD.
- Karpur, P., Shankar P.M., Rose, J.L., and Newhouse, V.L. (1987). "Split spectrum processing: optimizing the processing parameters using minimization," *Ultrasonics* 25, 204.
- \_\_\_\_\_. (1988). "Split spectrum processing: determination of the available bandwidth for spectral splitting," *Ultrasonics* 26, 204-206.
- Kennedy, T.R. (1977 Oct). "Polymer impregnation of new concrete bridge decks," Final Report, Federal Highway Administration, 1-78.
- Krautkramer, J., and Krautkramer, H. (1977). *Ultrasonic testing of materials*. 2nd ed., Springer-Verlag, New York.
- Kukacka, L.E., et al. (1975). "Concrete-polymer Materials for highway application," Report No. FHWA-RD-75-86, Federal Highway Administration, Washington, DC.
- Mailer, H., et al. (1970 Jul). "The development of ultrasonic nondestructive testing instrumentation to measure pavement thickness," Final Report EES 208, Engineering Experiment Station, Ohio State University, Columbus, OH.
- Malhotra, and Carino, eds. (1991). *Handbook on nondestructive testing of concrete*. 1st ed., CRC Press, Inc., Boca Raton, FL.
- Marks, V.J. (1990). "High molecular weight methacrylate sealing of a bridge deck," Transportation Research Record 1204, 83-88.
- McEwan, W., Abou-Ali, M., and Belavendram, N. (1991). "Parameter design and expert systems in NDT," *The British Journal of Non-Destructive Testing* 33(3).
- McMaster, R.C. (1959). "Ultrasonic test principles," *Nondestructive Testing Handbook II* (43), Ronald Press Company, New York.
- Miller, Benjamin F. (1967). *The complete medical guide*. Simon and Schuster, New York.
- Newhouse, V.L., Bilgutay, N.M., Saniie, J., and Furgason, E.S. (1982 Mar). "Flaw-to-grain echo enhancement by split-spectrum processing," *Ultrasonics*, 62-63.

- Nugent, M.J. (1996). "Hand held tube wall thickness ultrasonic measurement probe and system," United States Patent 5,549,004, Aug 27, 1996, Washington, DC.
- O'Connor, D.N., and Saiidi, M.S. (1993 Jan/Feb). "Compatibility of polyester-styrene polymer concrete overlays with portland cement concrete bridge decks," *ACI Materials J.*, 59-68.
- Olson, L.D., et al. (1995). "Scanning apparatus and method for nondestructive materials evaluation and mapping through use of acoustic waves," U.S. Patent 5,404,755, U.S. Patent Office, Washington, DC.
- Oppenheim, A.V., and Shafer, R.W. (1975). *Digital signal processing*. Prentice-Hall, Inc., Englewood Cliffs, NJ.
- Pickett, G. (1945). "Equations for computing elastic constants from flexural and torsional resonant frequencies of vibration of prisms and cylinders," *Proceedings, American Society for Testing and Materials* 45, 846.
- Plum, D.R. (1990 Sep). "The behavior of polymer materials in concrete repair, and factors influencing selection," *The Structural Engineer* 68(17), 337.
- Portland Cement Association. (1965-1970). "Durability of concrete bridge decks," Reports 1-6, A Cooperative Study of Ten States, U. S. Bureau of Public Roads, Portland Cement Association.
- Prowell, B.D., Weyers, R.E., Cady, P.D., and Al-Qadi, I.L. (1993). "Field service life performance of deep polymer impregnation as a method for protecting bridge decks from corrosion," Virginia Polytechnic Inst. and State University, Transportation Research Record n1392, 117-125.
- Robinson, E.A. (1983). *Seismic velocity analysis and the convolutional model*. International Human Resources Development Corporation, Boston, 187-196.
- Rodler, D.J., Whitney, D.P., Fowler, D.W., and Wheat, D.L. (1989). "Repair of cracked concrete with high molecular weight methacrylate monomers," *Polymers in Concrete*, ACI SP-116, American Concrete Institute, 113-125.
- Saniie, J., Donohue, K.D., and Bilgutay, N.M. (1990). "Order statistic filters as postdetection processors," *IEEE Trans. Acoustic Speech Signal Processing*, P.X.
- Saniie, J., Nagle, D.T., and Donohue, K.D. (1991). "Analysis of order statistic filters applied to ultrasonic flaw detection using split-spectrum

- Saniie, J., Nagle, D.T., and Donohue, K.D. (1991). "Analysis of order statistic filters applied to ultrasonic flaw detection using split-spectrum processing," *IEEE Transactions on Ultrasonics, Ferroelectrics, and Frequency Control* 3(2), 133.
- Sansalone, M., and Carino, N.J. (1991). "Stress wave propagation methods," *Handbook on nondestructive testing of concrete*. Malhotra and Carino, eds., 1st ed., CRC Press, Boca Raton Inc., FL.
- Scarpinato, E.J. (1985). "Thin polymer concrete bridge deck overlays and the brooklyn bridge," *2nd Annual International Bridge Conference, IBC, June 17-19, 1985*, 165-169.
- Simons, G.L. (1984). *Introducing artificial intelligence*. NCC Publications, The National Computing Centre Ltd, Oxford Road, Manchester, England.
- Smithson, L.D., and Whiting, J.E. (1992 Jun/Jul). "Rebonding delaminated bridge deck overlays — epoxy injection proves to be an effective method," *Concrete Repair Digest*, 100-101.
- Smoak, W.G. (1978). "Polymer impregnation of new concrete bridge deck surfaces," Report No. FHWA-RD-78-5, Final Report, Federal Highway Administration, Washington, DC.
- Sprinkel, M.M. (1991). "Use of HMWM monomer to seal cracks in bridge decks, retard alkali-silica aggregate reactions, and prime bridge surfaces for overlays," *Transportation Research Record* 304, 75-86.
- \_\_\_\_\_. (1992). "Use of high molecular weight methacrylate monomers to seal cracks in bridge decks, retard alkali-silica-aggregate reactions, and prime bridge surfaces for overlays," *Transportation Research Record, 71st Annual Meeting*, Washington. DC.
- \_\_\_\_\_. (1993). "Performance of multiple layer polymer concrete overlays on bridge decks." *Polymers in concrete: advances and applications*. Pete Nendis and Charles McClasky, Editors, American Concrete Institute SP 116, 61-95.
- Sprinkel, M.M., and Weyers, R.E. (1993). "Rapid concrete bridge deck protection, repair and rehabilitation," SHRP-S-344.
- Sprinkel, M.M., Weyers, R.E., and Sellars, A.R. (1991). "Rapid techniques for the repair and protection of bridge decks," *Transportation Research Record* 304, 75-86.
- Surlaker, S. (1992). "Evaluation and testing of polymers for repairs," *The Indian Concrete J.* 66(3), 145.

- Thornton, H.T., and Alexander, A.M. (1987). "Development of non-destructive testing systems for in situ evaluation of concrete structures," Technical Report REMR-CS-10, U.S. Army Engineer Waterways Experiment Station, Vicksburg, MS.
- Tourney, P., and Berke, N. (1993 Apr). "A call for standardized tests for corrosion-inhibiting admixtures," *Concrete International*, American Concrete Institute, 57-62.
- Tracy, R.G., and Fling R.S. (1989 Sep). "Rehabilitation strategies," *Concrete International*, American Concrete Institute, 41-45.
- Transportation Research Board. (1970). "Concrete bridge deck durability," Synthesis of Highway Practice No. 4, Transportation Research Board, 28 pp.
- \_\_\_\_\_. (1979). "Durability of concrete bridge decks," Synthesis of Highway Practice No. 57, Transportation Research Board, 61 pp.
- \_\_\_\_\_. (1983 Apr). "Long-term rehabilitation of salt-contaminated bridge decks," Transportation Research Record NCHRP 257, National Research Council.
- Tremper, B. (1960). "Repair of damaged concrete with epoxy resins," *J. of the American Concrete Institute* 57, 173-182.
- U.S. Army Engineer Waterways Experiment Station. (1949 with quarterly supplements). *Handbook for concrete and cement*. Vicksburg, MS.
- a. CRD-C 57 "Standard practice for petrographic examination of hardened concrete (ASTM C 856-95)."
  - b. CRD-C 127 "Standard practice for petrographic examination of aggregates for concrete (ASTM C 295-90)."
  - c. CRD-C 139 "Standard descriptive nomenclature of constituents of natural mineral aggregates (ASTM C 294-86)."
- Vaysburd, A.M. (1993 Mar). "Some durability considerations for evaluating and repairing concrete structures," *Concrete International*, 29-35.
- Weyers, P.E., and Cady, P.D. (1990 Jun). "Deep impregnation of concrete bridge decks," *Public Works*, 70-74.
- Wiberg, U. (1993). "Material characterization and defect detection in concrete by quantitative ultrasonics," *TRITA-BKN, Bulletin 7*, Department of Structural Engineering, Royal Institute of Technology, Stockholm.

- Williams, R. (1993). "JARGON, an informal dictionary of computer terms," Peachpit Press, Berkeley, CA.
- Wu, H., and Brooman, E.W. (1993). "Study of use of ultrasound technology to prepare polymer-impregnated concrete," *Cement and Concrete Research* 23, 640-650.

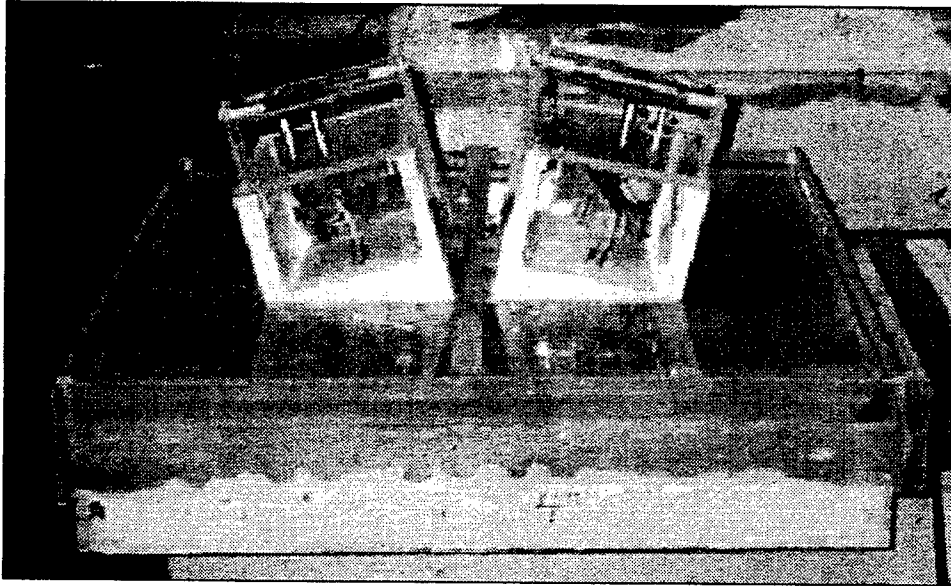

Figure 1. New transducers performing early static laboratory test

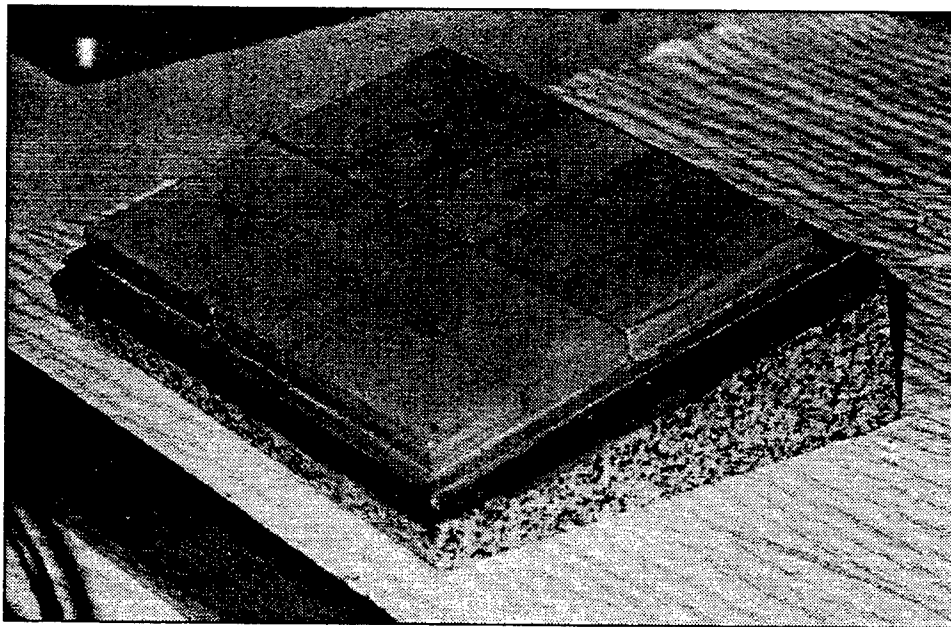

Figure 2. New WES UPE transducers during construction

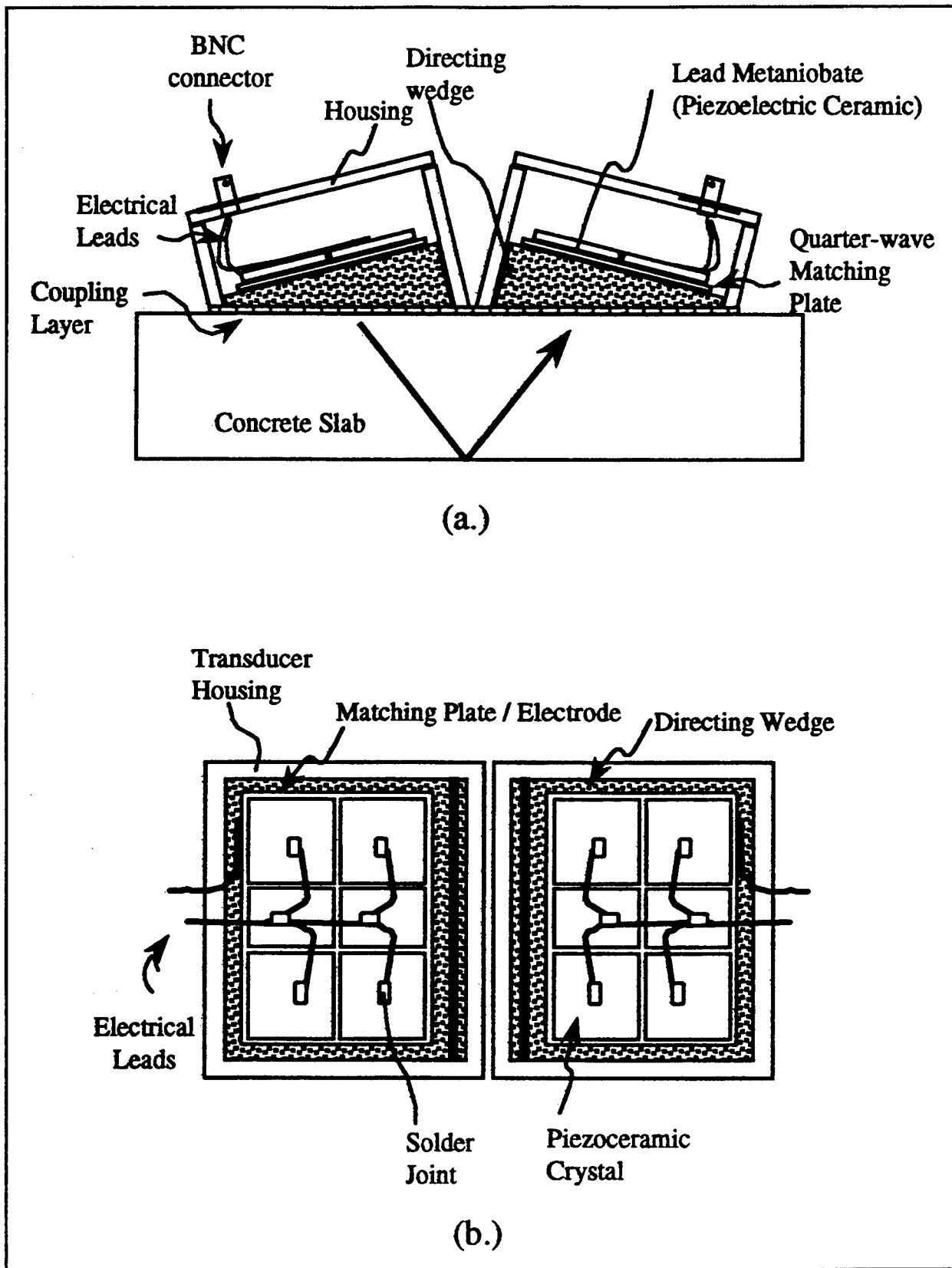

Figure 3. Diagram of new pitch-catch transducers (a) side view (b) top view

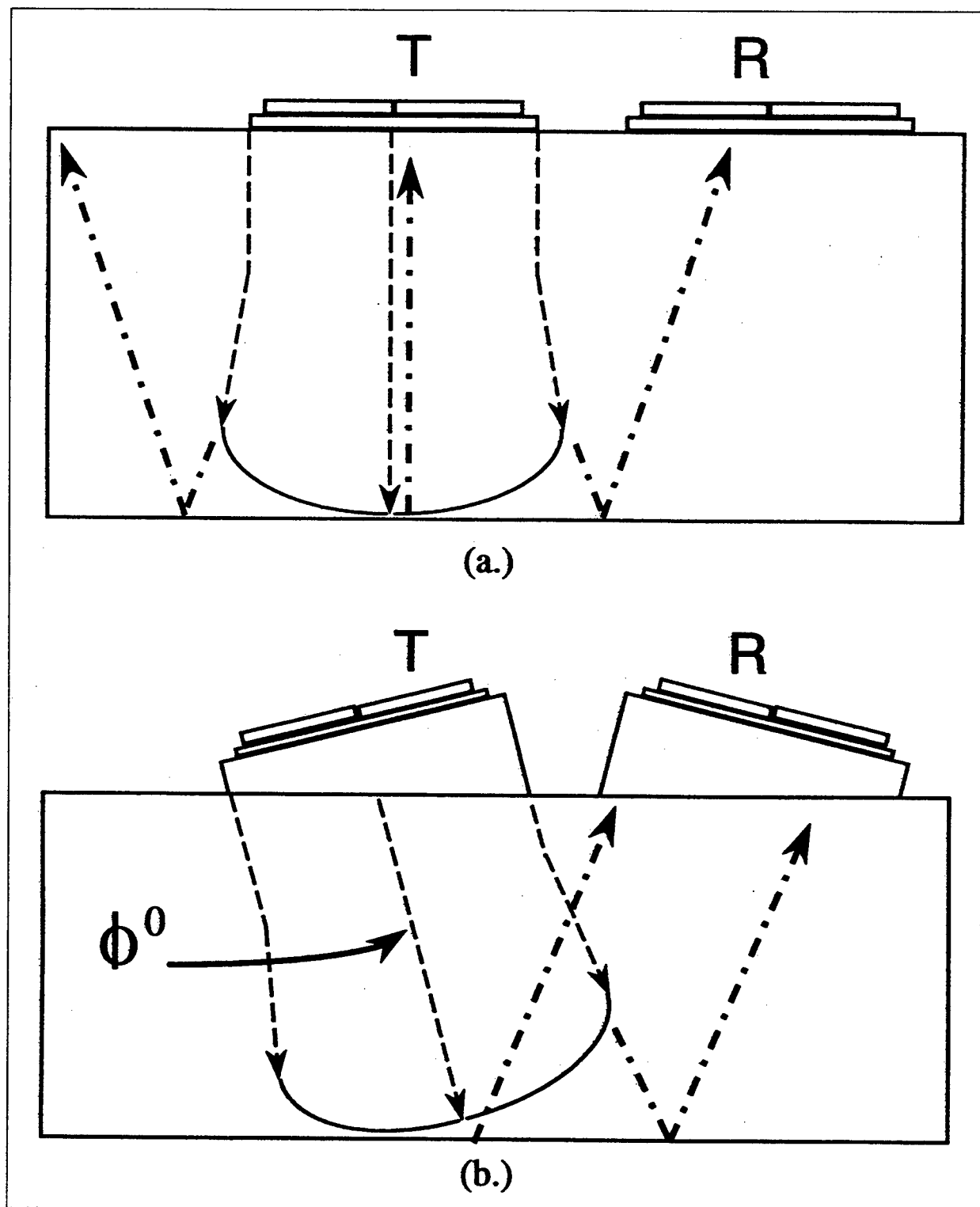

Figure 4. Pitch-catch mode configurations (a) Energy propagation with nondirected transducers. (b) Improved wavelength resolution and backwall-echo magnitude with directing wedge

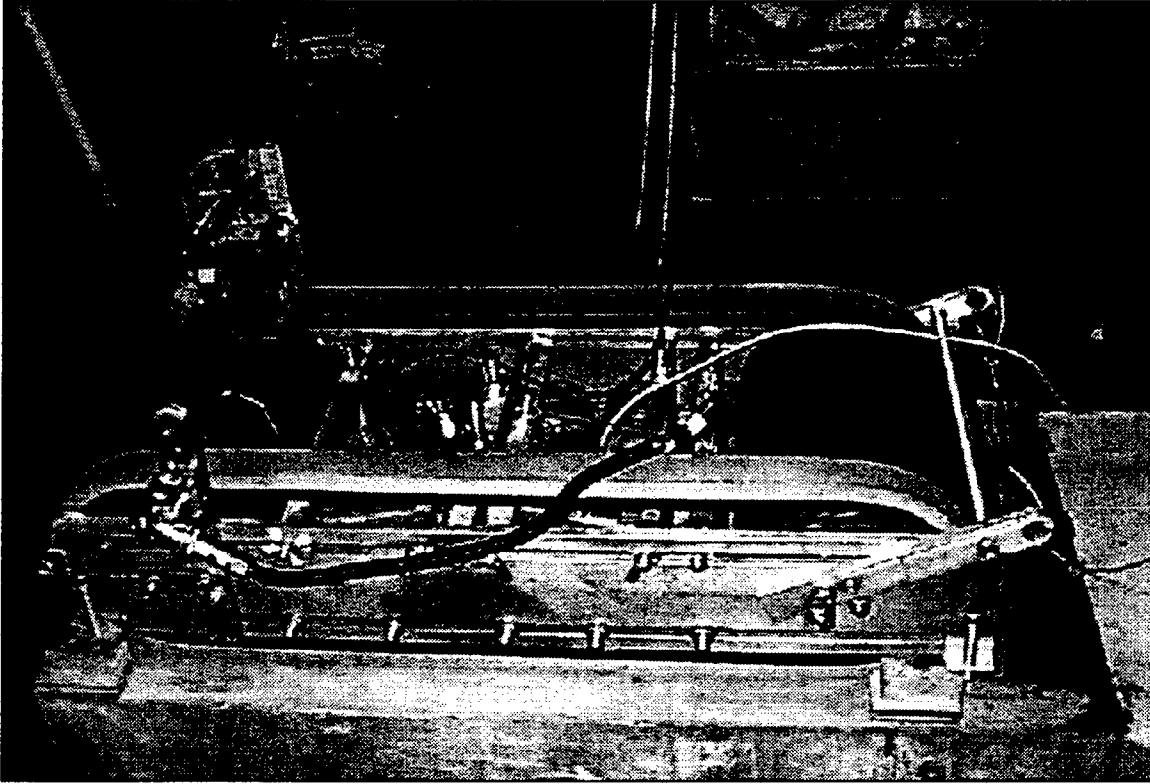

Figure 5. The rolling pond with accessories

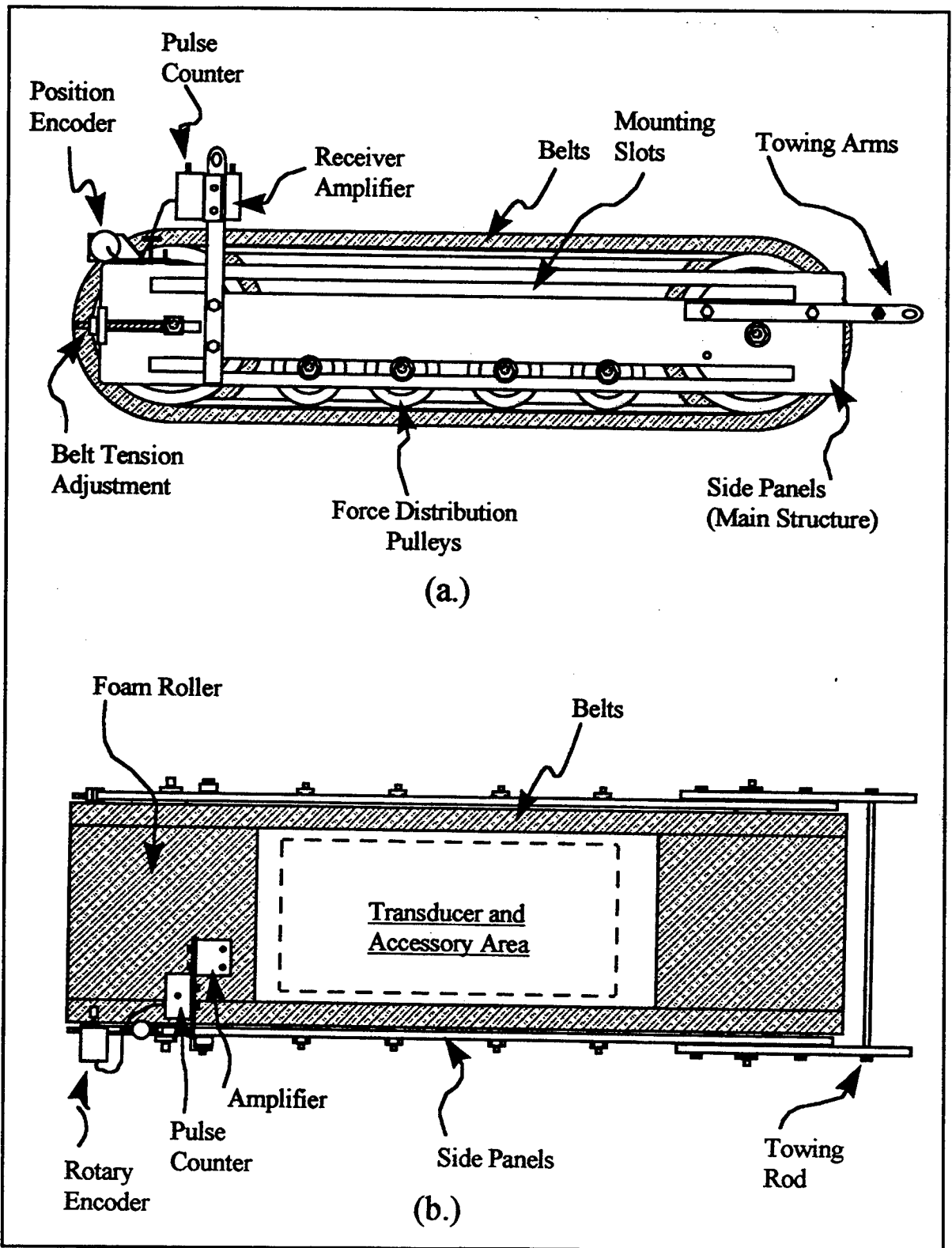

Figure 6. Diagram showing frame of rolling pond and accessories(a) side view (b) top view

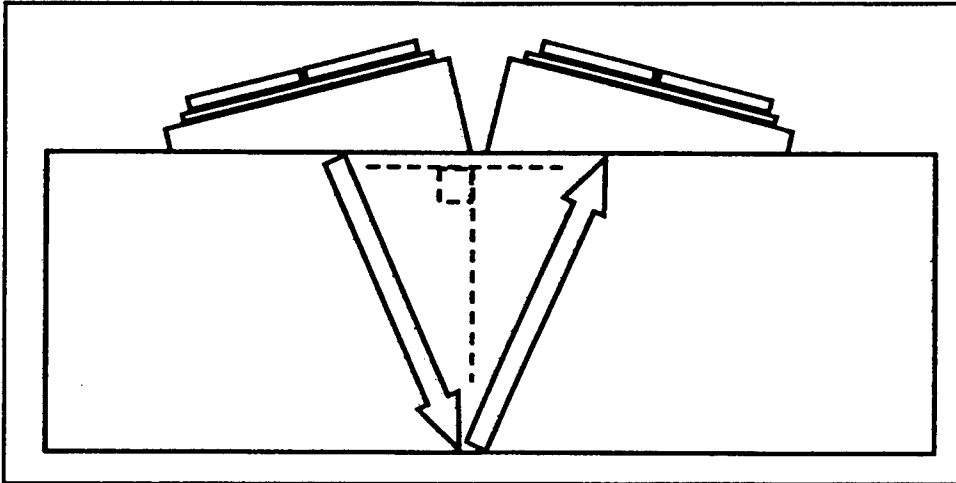

Figure 7. Diagram showing right triangles used for ray analysis

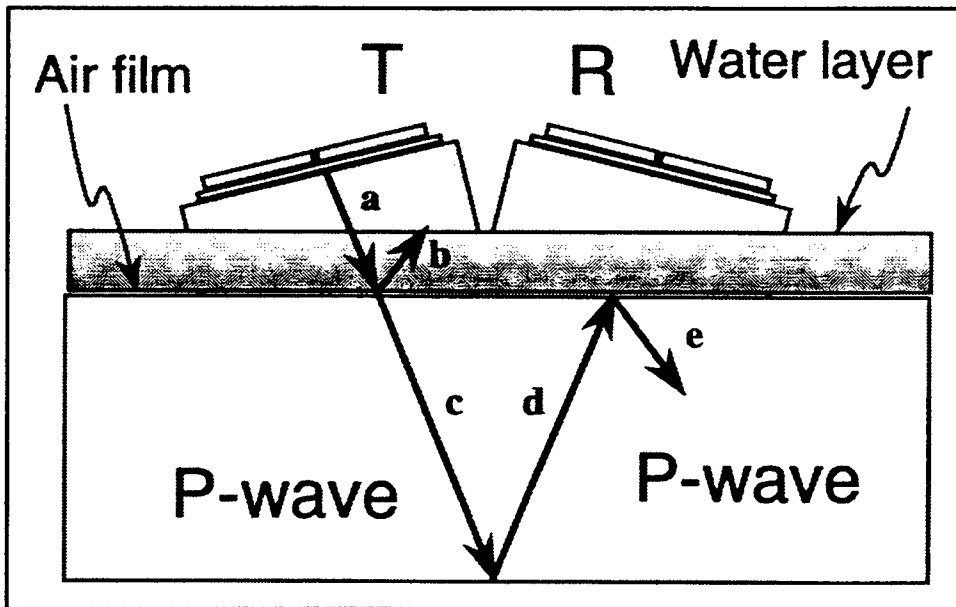

Figure 8. Loss of energy occurring at an air film interface

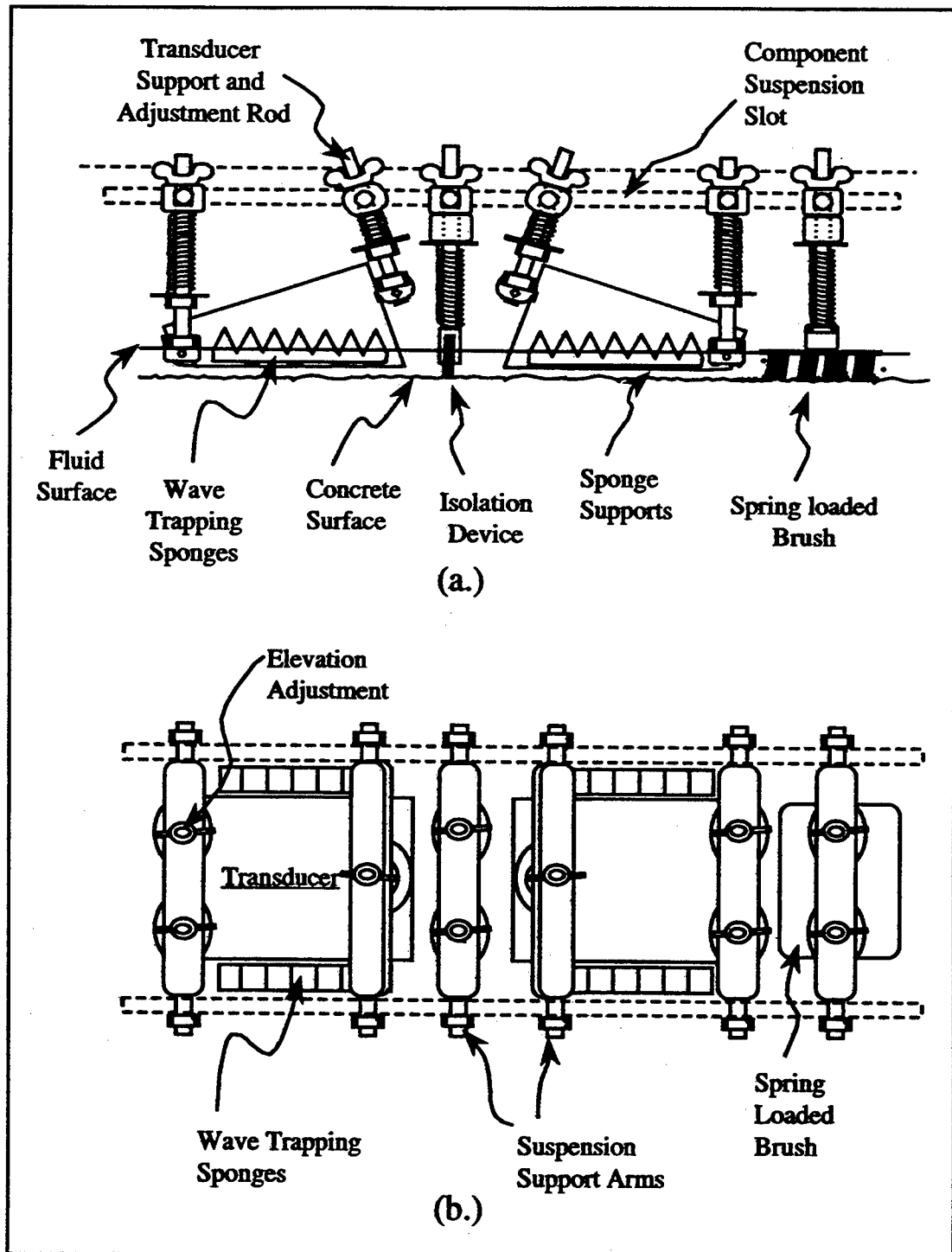

Figure 9. Rolling pond's interior components (a) side view (b) top view

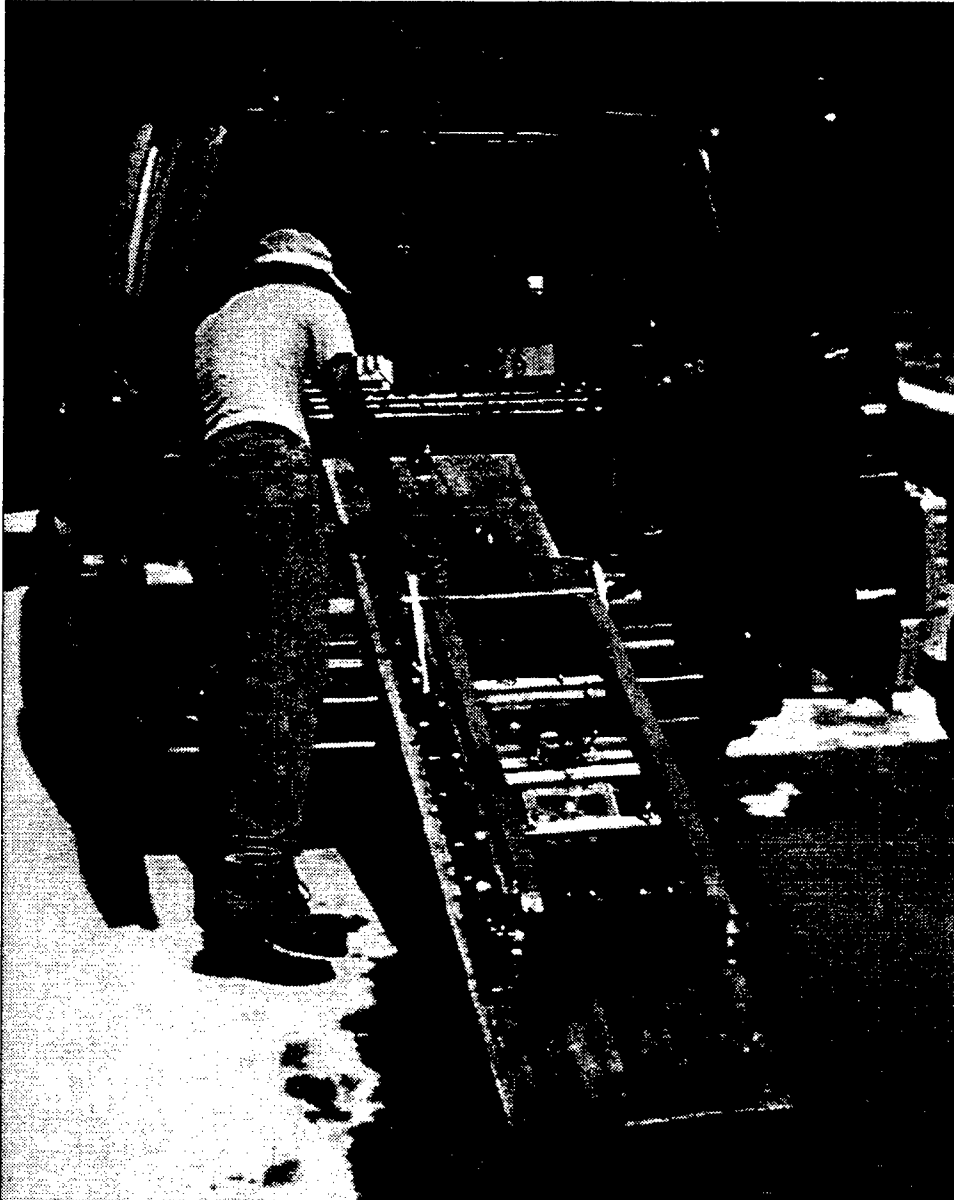

Figure 10. The SUPERSCANNER being loaded into the instrumentation van

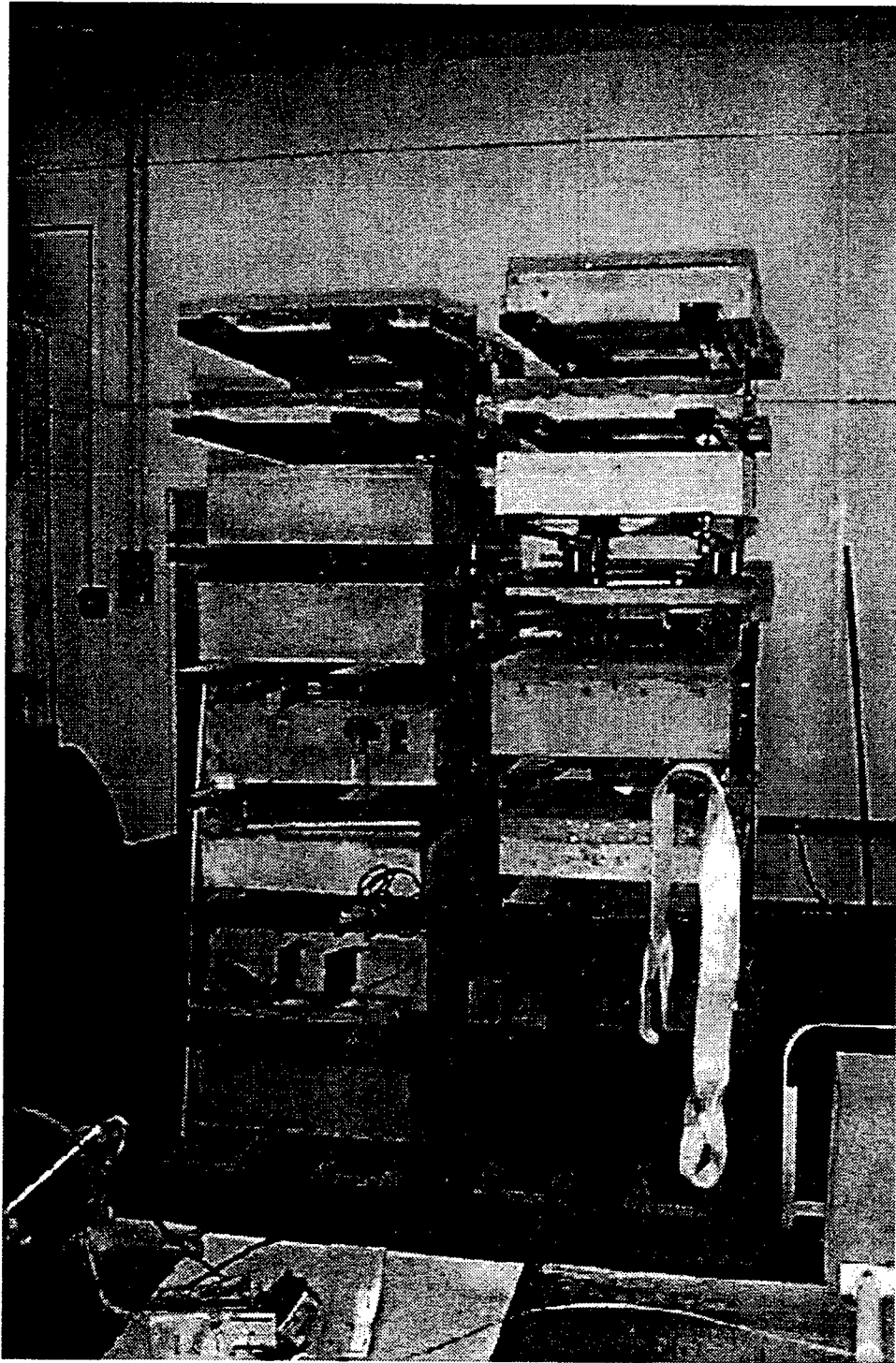

Figure 11. Laboratory test specimens

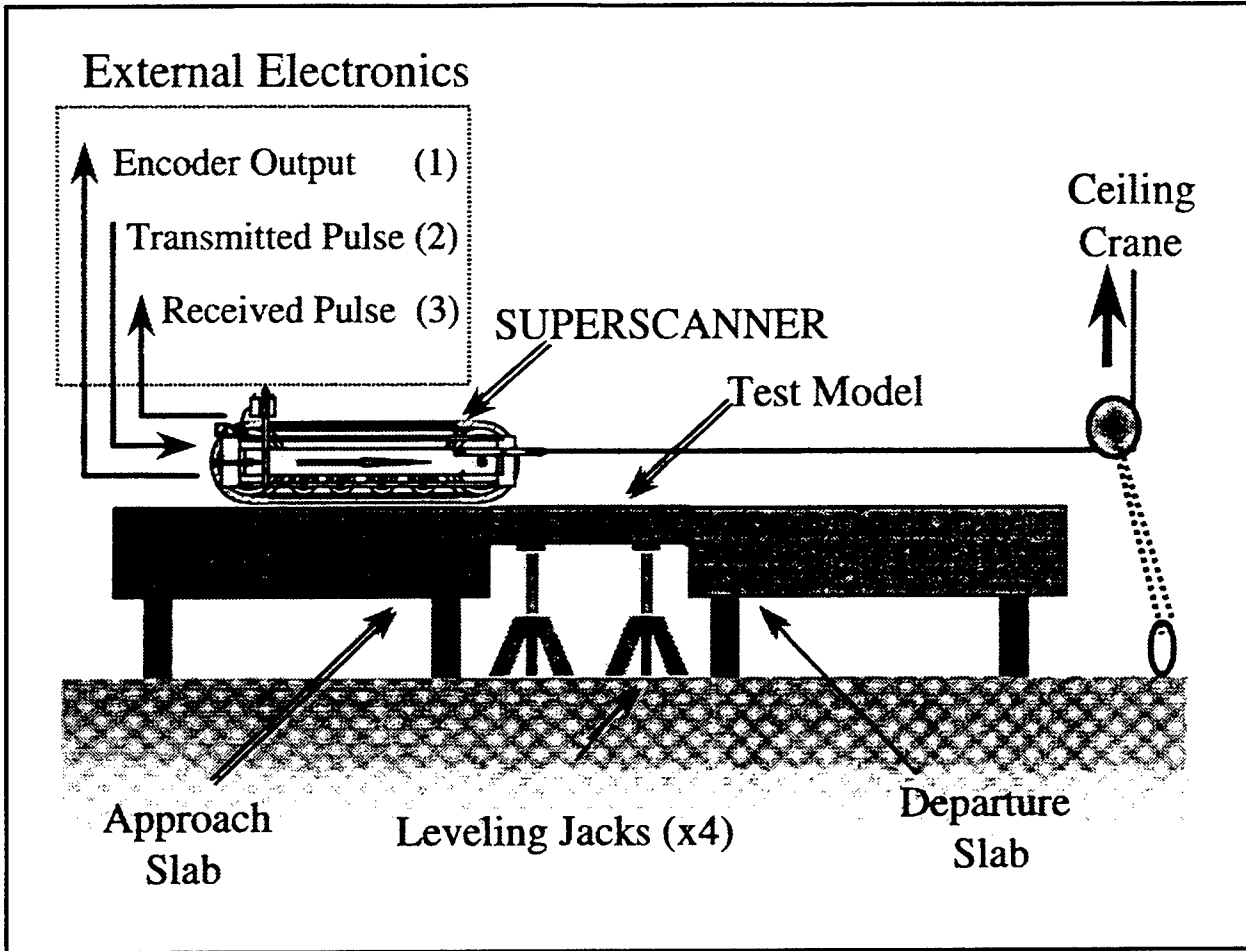

Figure 12. Diagram of the laboratory test bed used to test specimen models

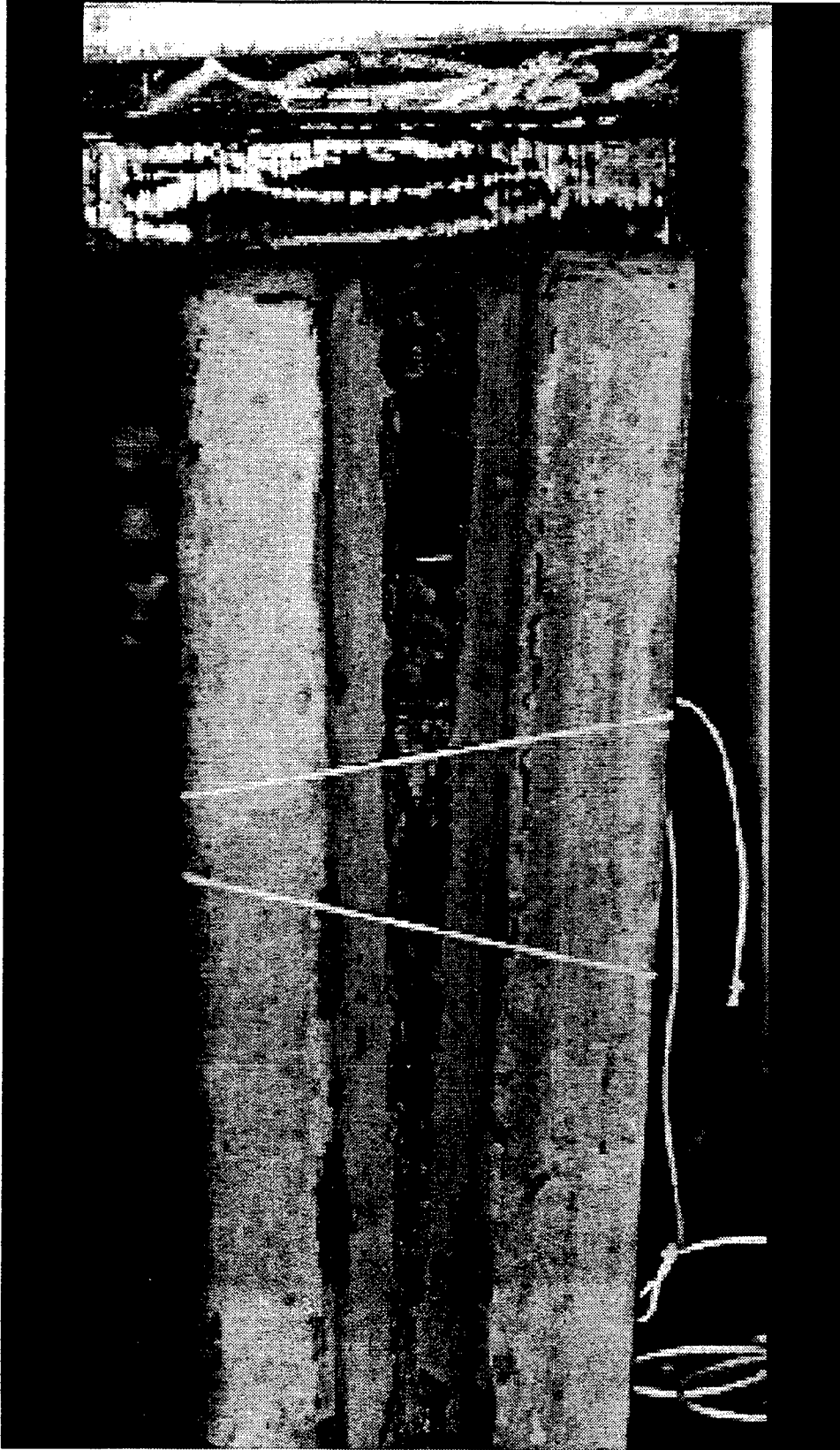

Figure 13. Shearing a concrete specimen to produce a delamination evaluation model

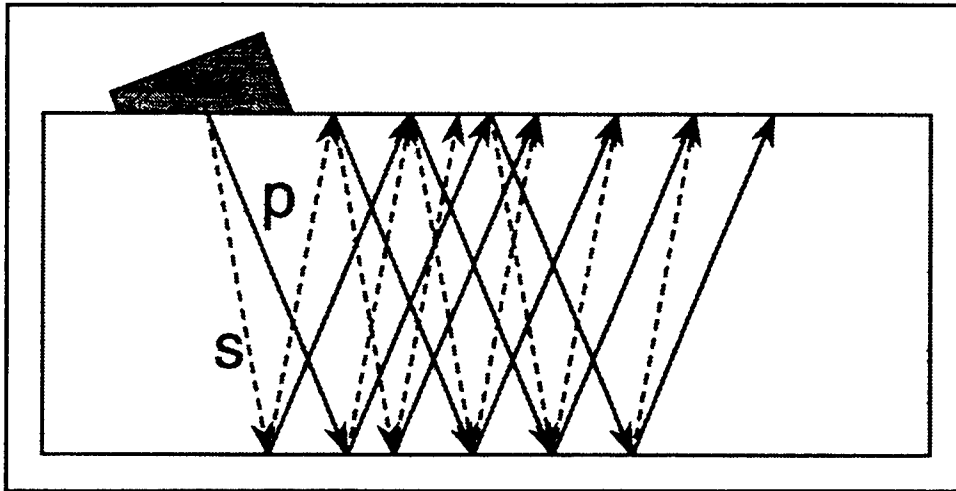

Figure 14. Ray-based modeling used to calculate arrival times and positions of propagating waves

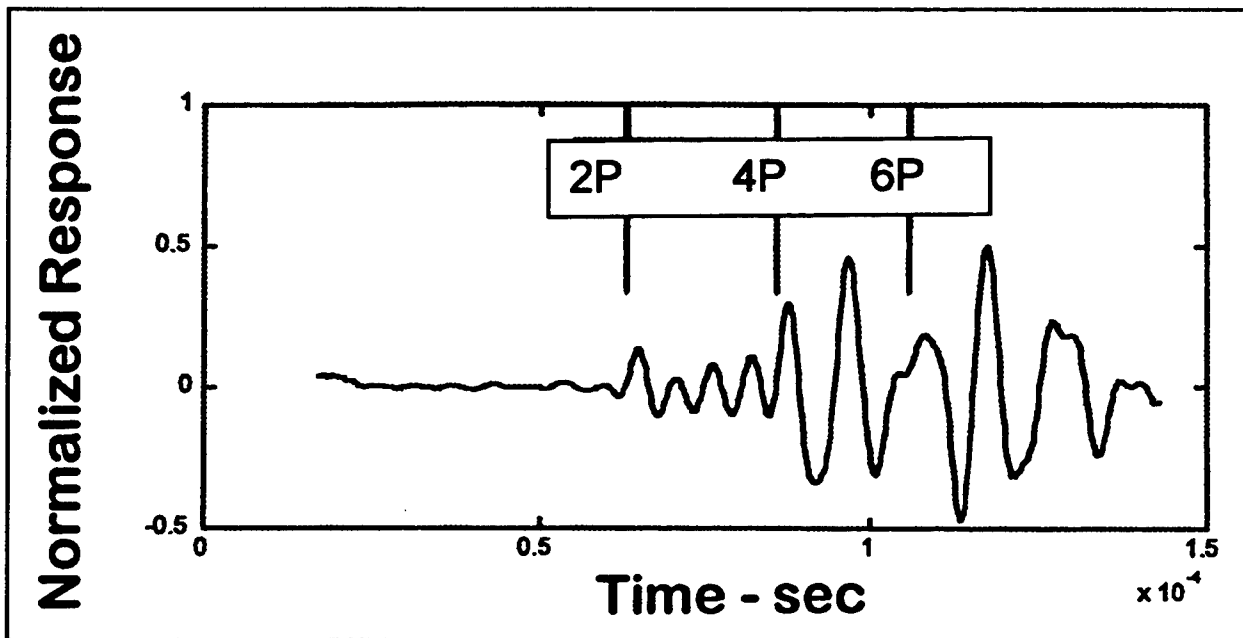

Figure 15. P-wave arrival calculated by RBM program for a 2-in-thick specimen

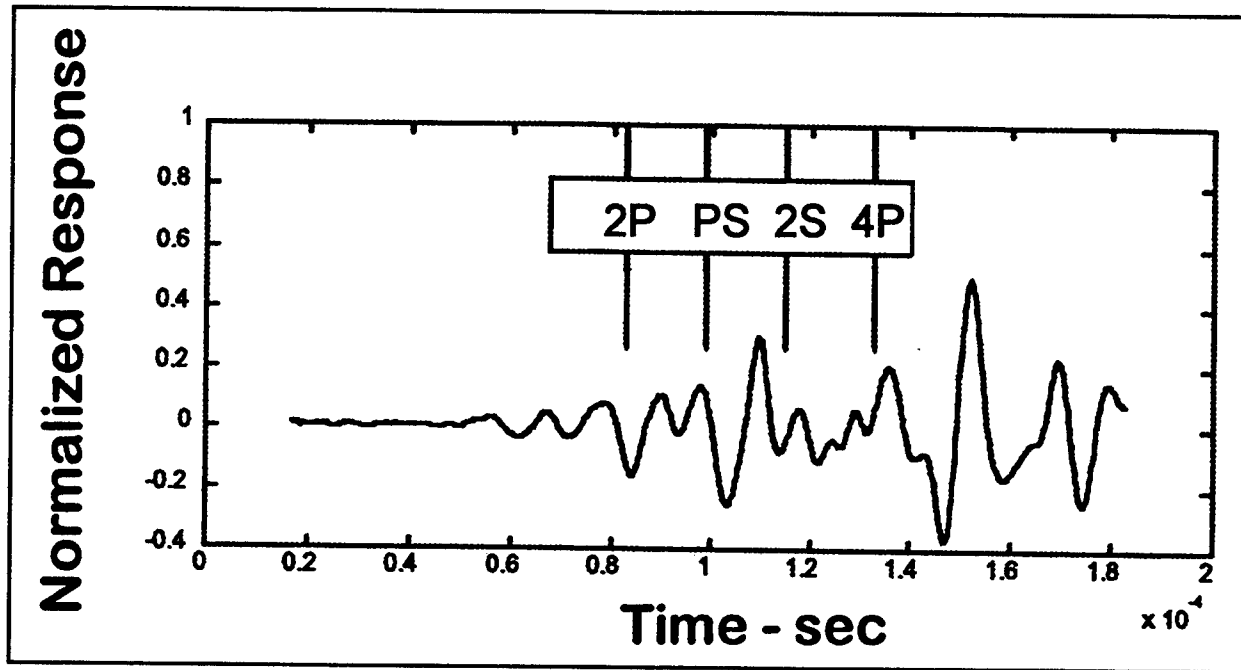

Figure 16. P, S, and PS-wave arrivals calculated by the RBM program for a 4-in.-thick specimen

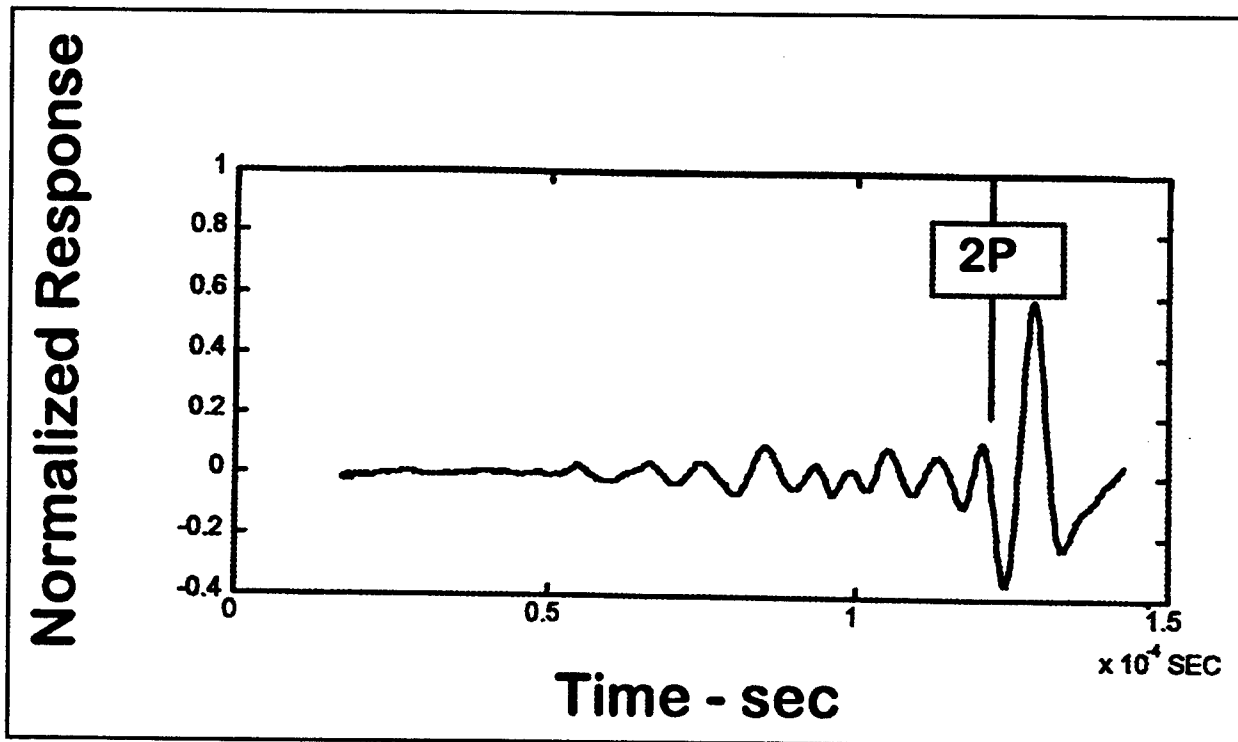

Figure 17. P-wave arrival calculated by RBM program for a 8-in.-thick specimen

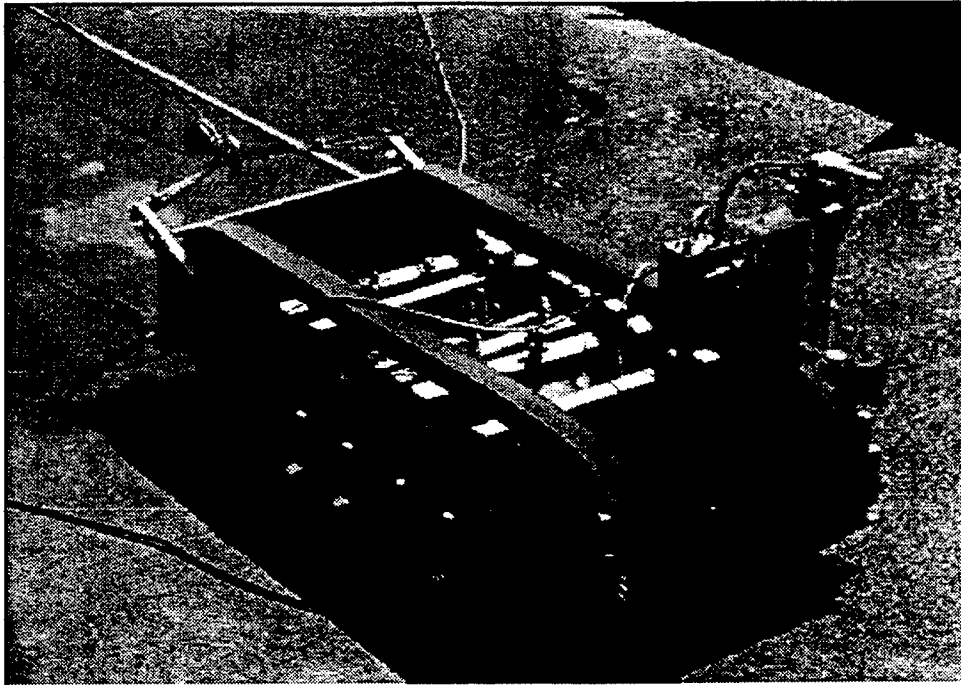

Figure 18. The SUPERSCANNER during bridge deck testing

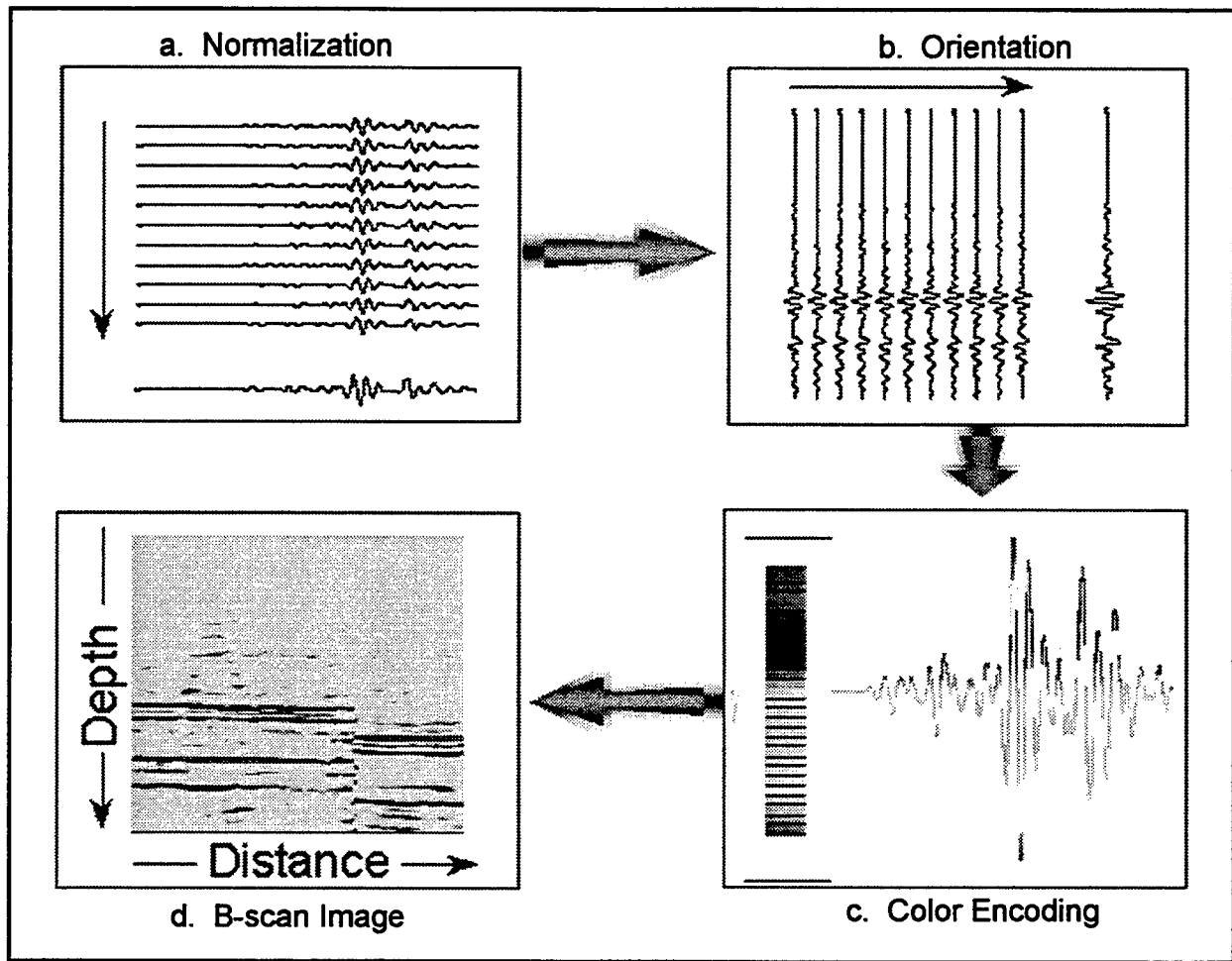

Figure 19. B-scan mapping procedure

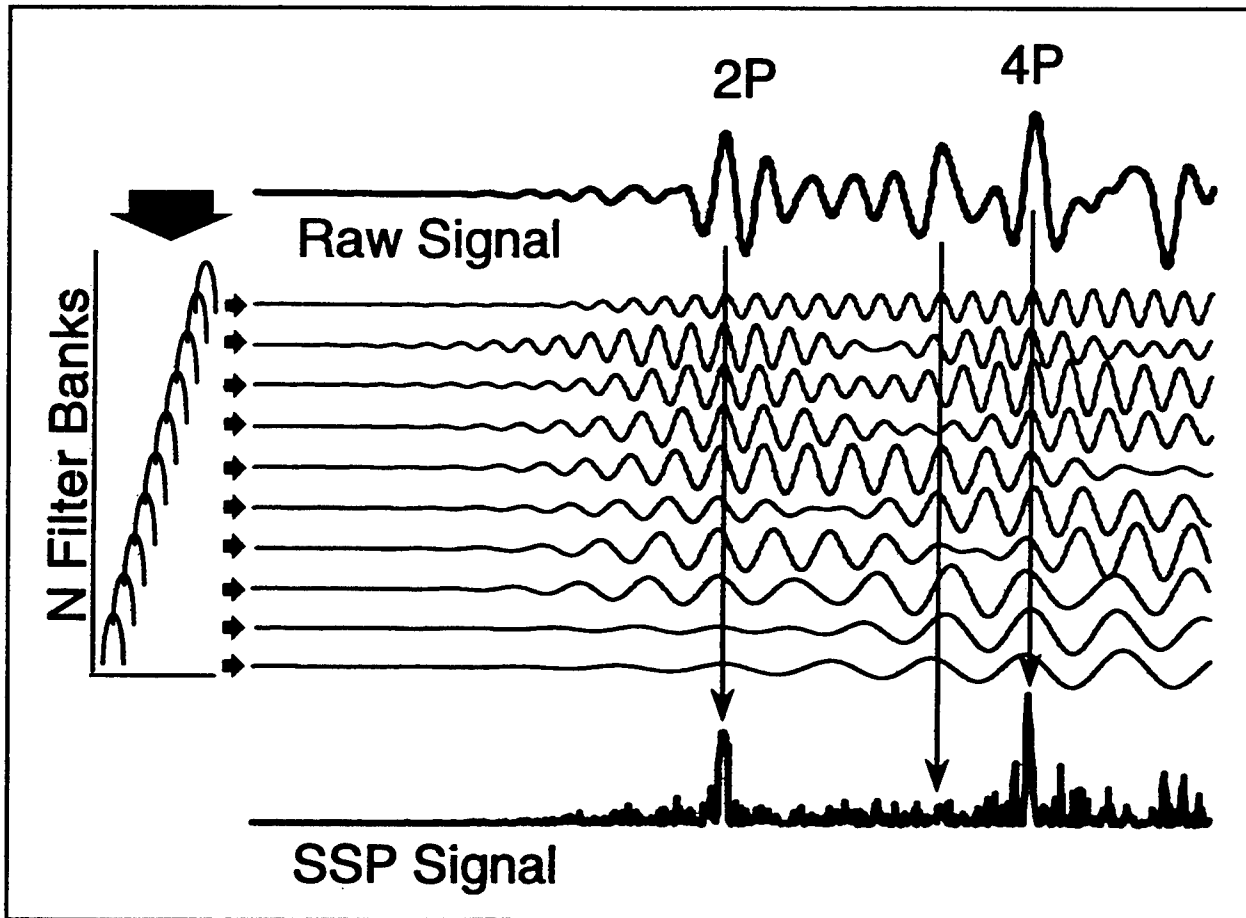

Figure 20. Representation of the SSP filtering and recombination procedure

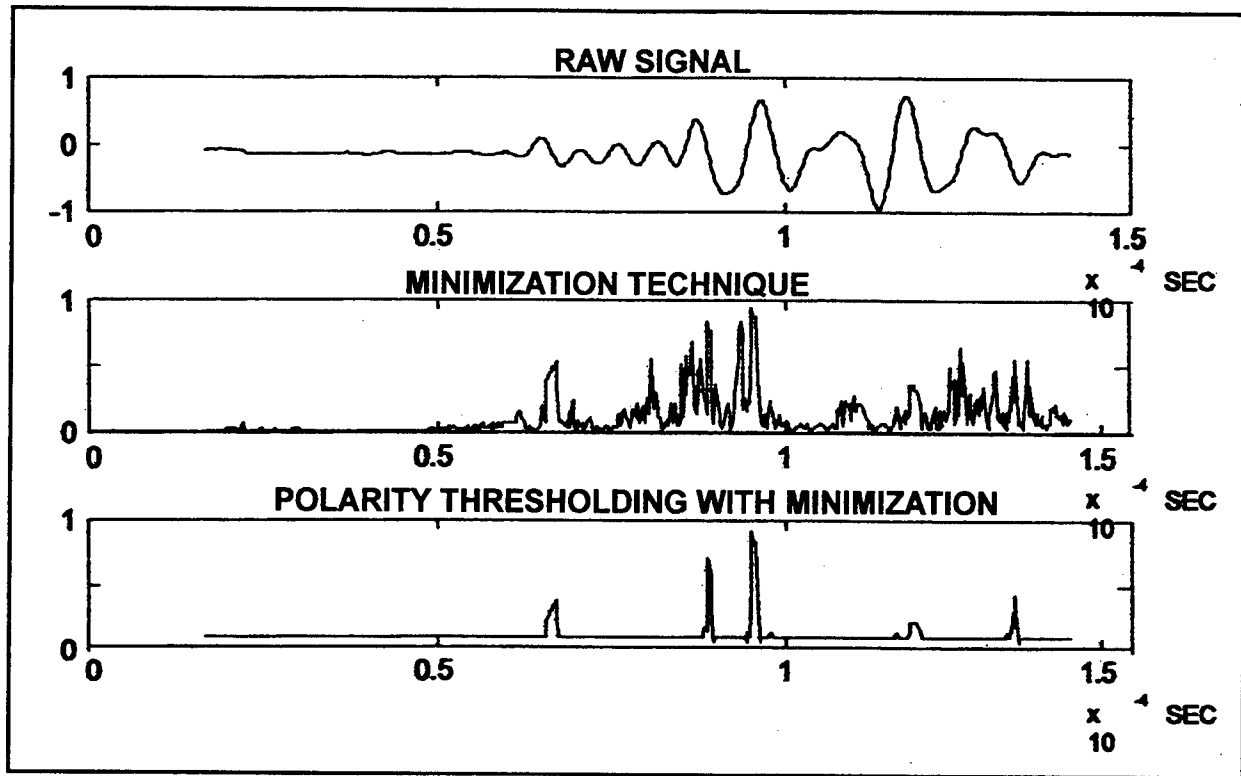

Figure 21. SSP with minimization and polarity thresholding for a 2-in.-thick concrete slab

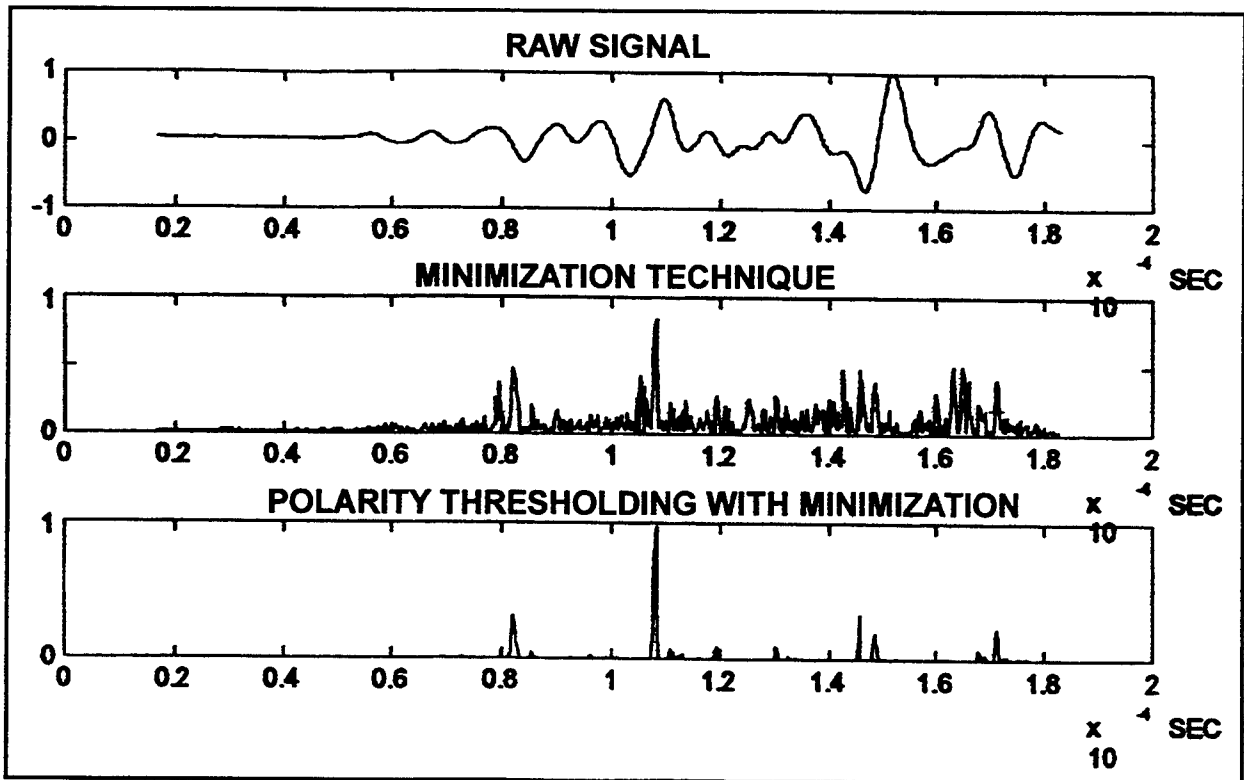

Figure 22. SSP with minimization and polarity thresholding for a 4-in.-thick concrete slab

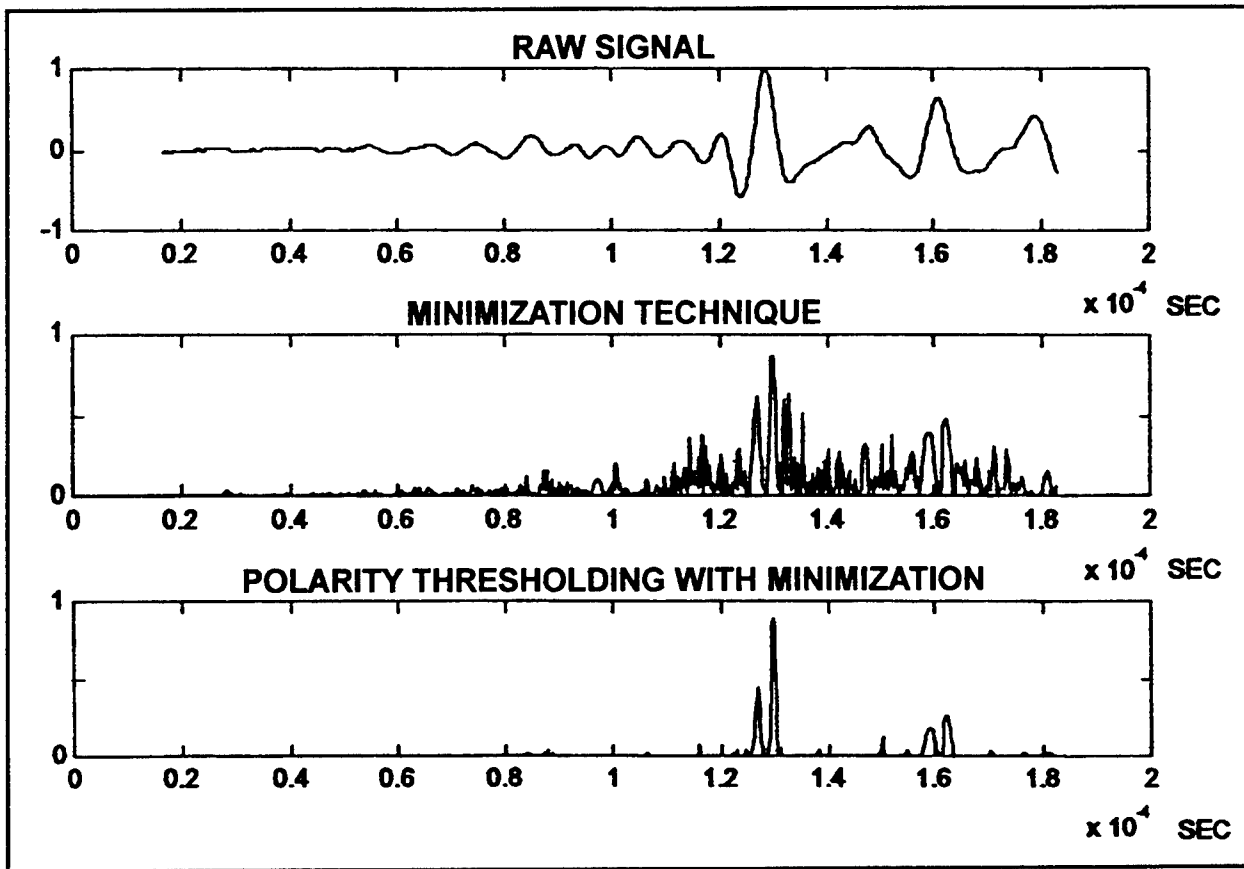

Figure 23. SSP with minimization and polarity thresholding for an 8-in.-thick concrete slab

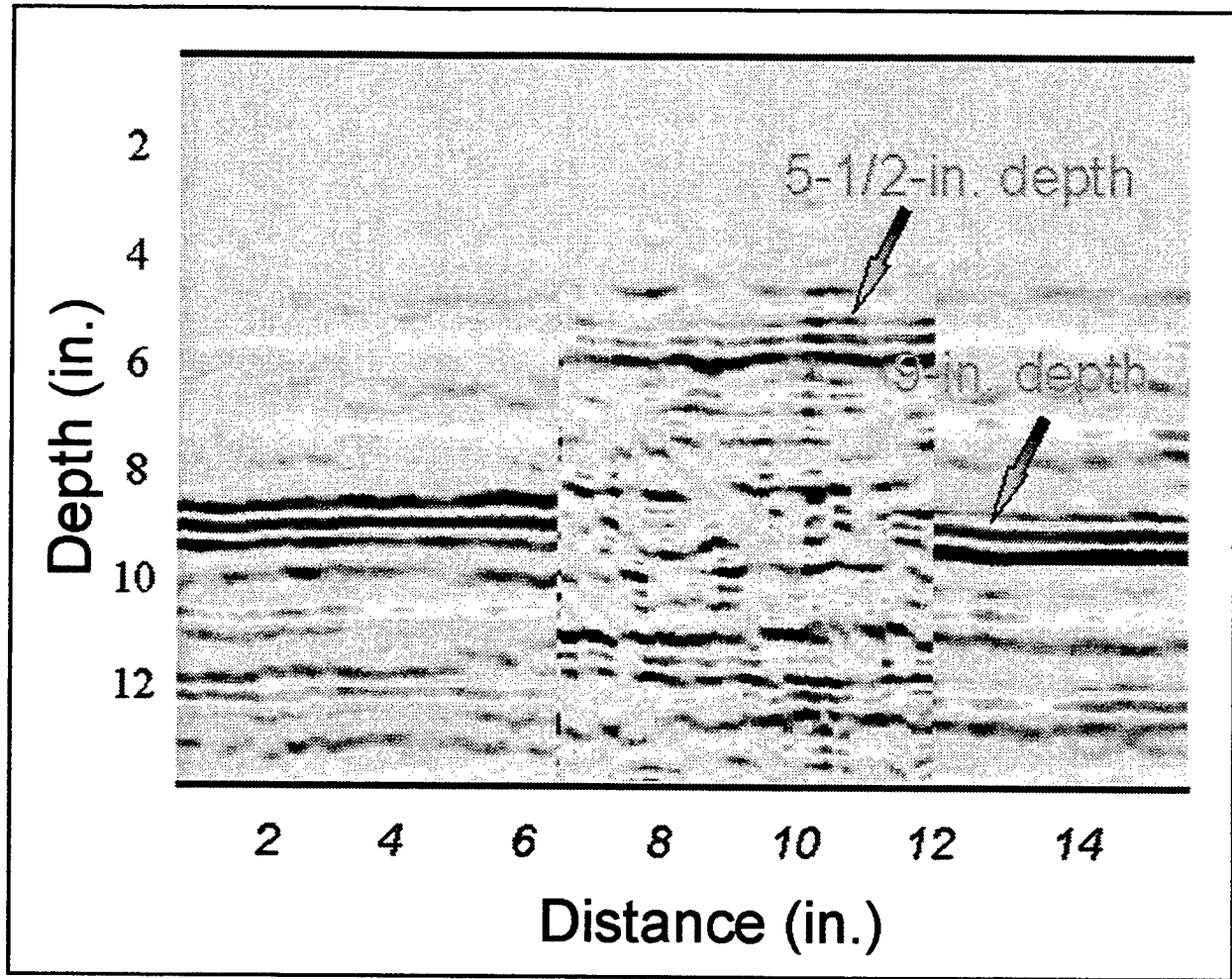

Figure 24. B-scan from the SUPERSCANNER's 9-in.-thick test bed and a 5-1/2-inch-thick model

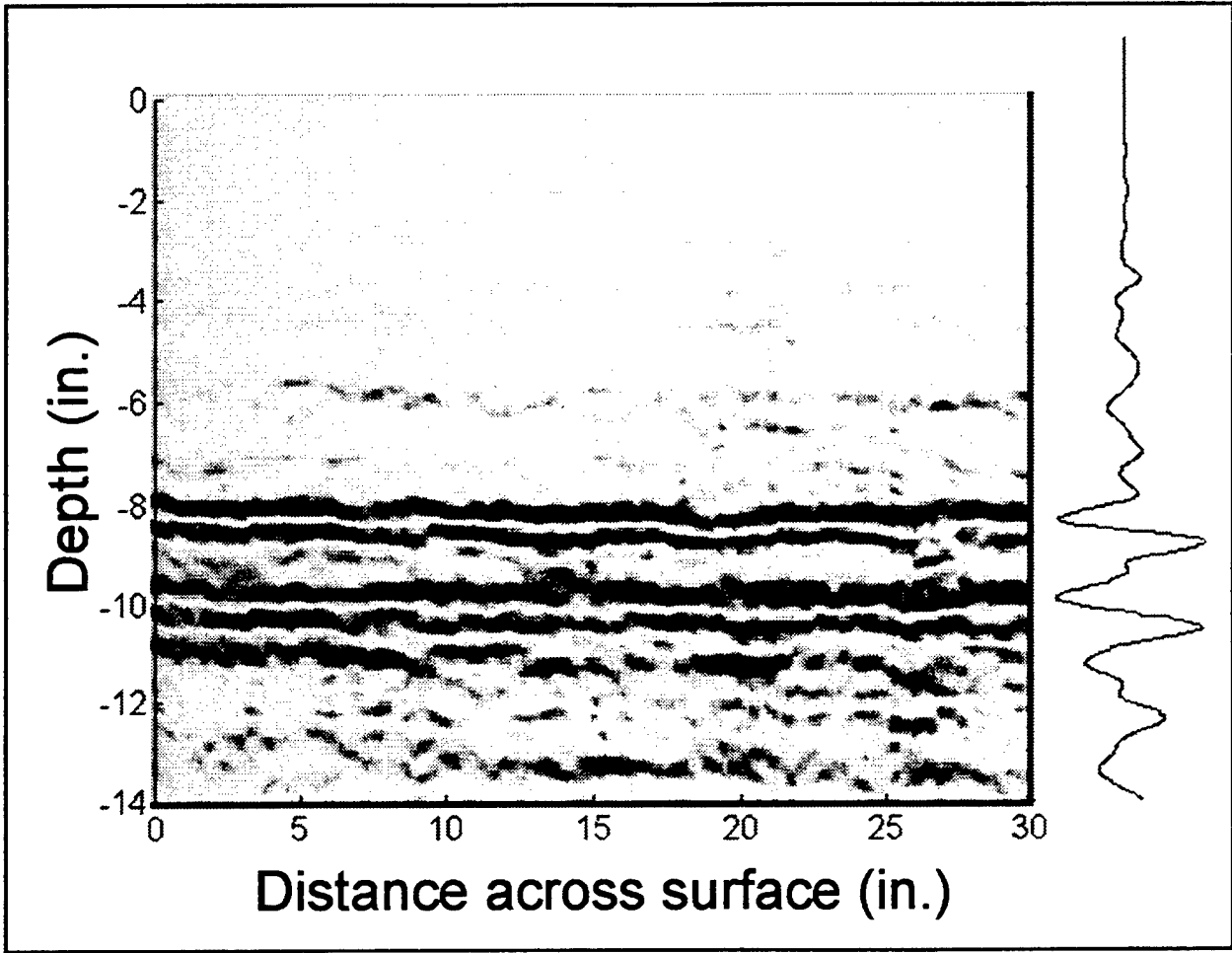

Figure 25. B-scan from an 8-in.-thick concrete bridge deck

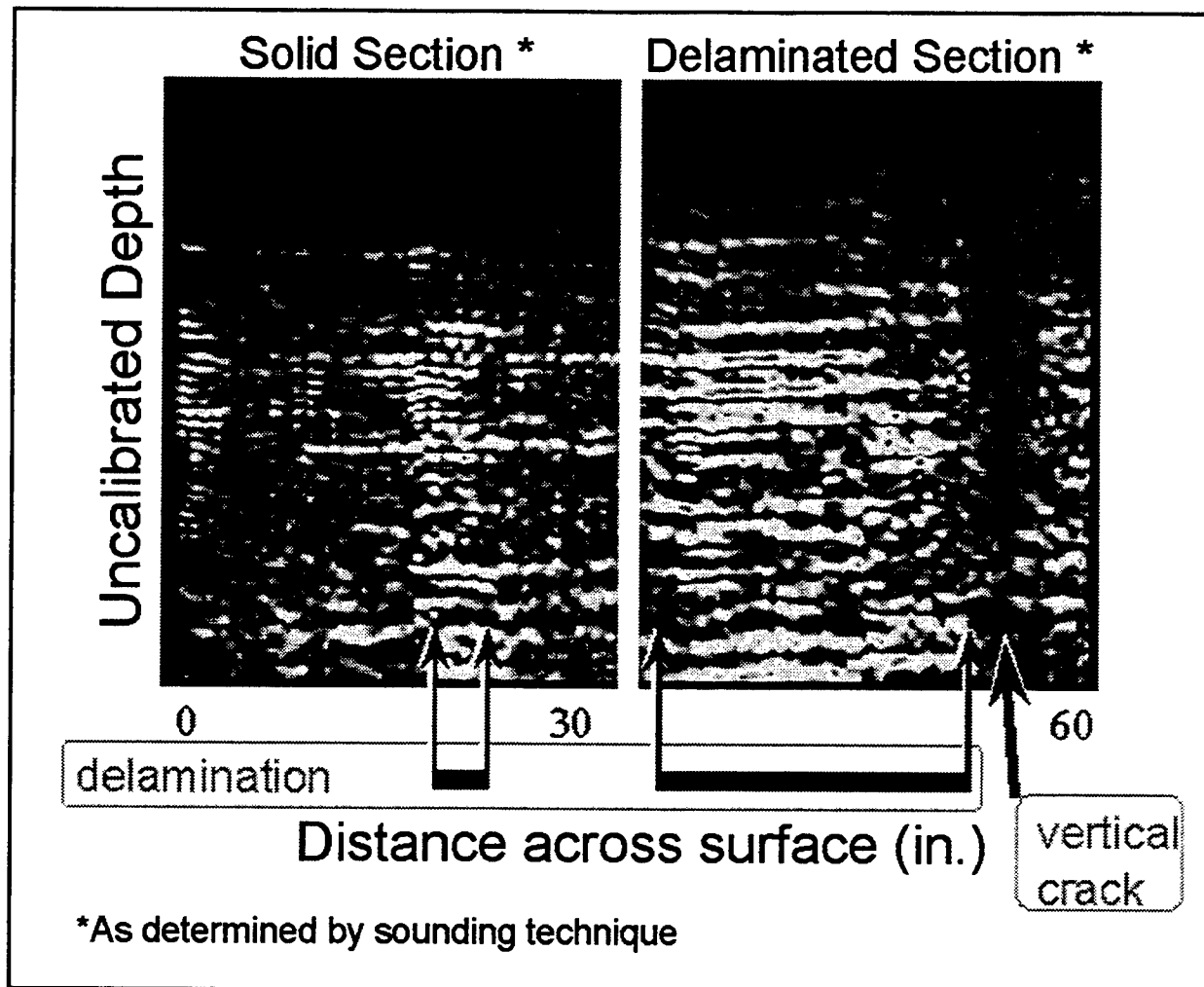

Figure 26. Delamination detection in a concrete bridge deck with a tined concrete overlay

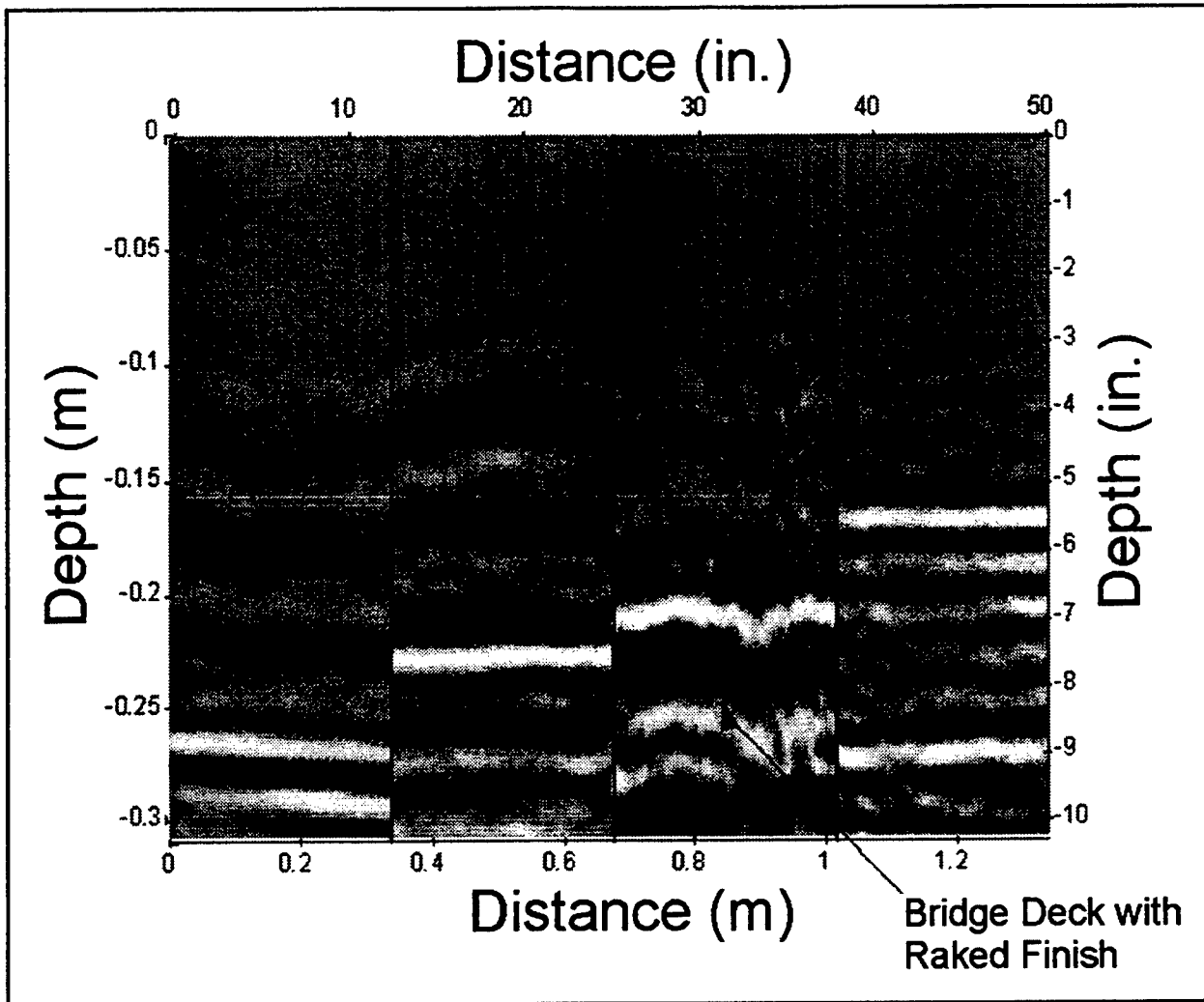

Figure 27. B-scan sections showing backwall reflections from concrete slabs of various thickness

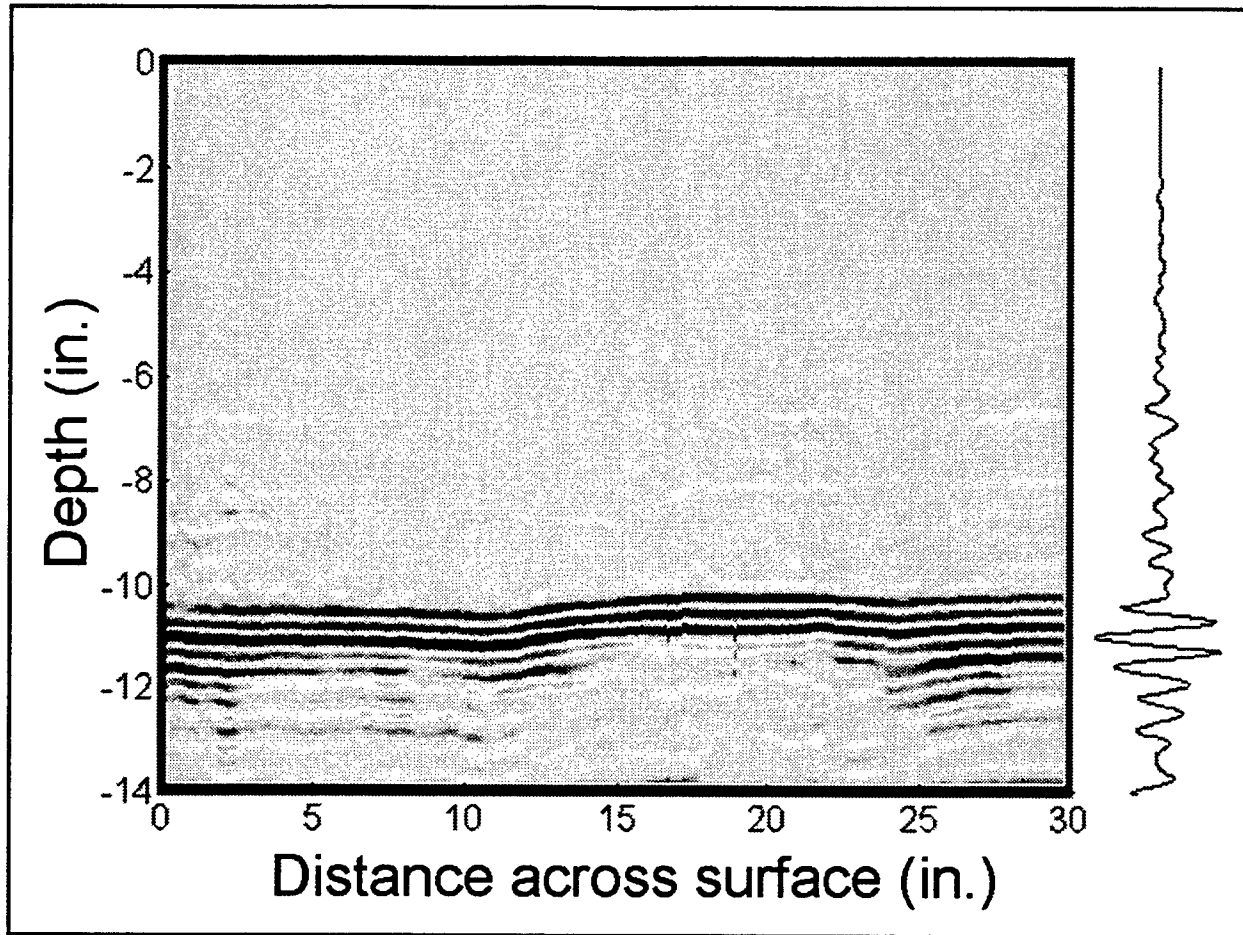

Figure 28. B-scan from an 11-inch-thick reinforced concrete slab

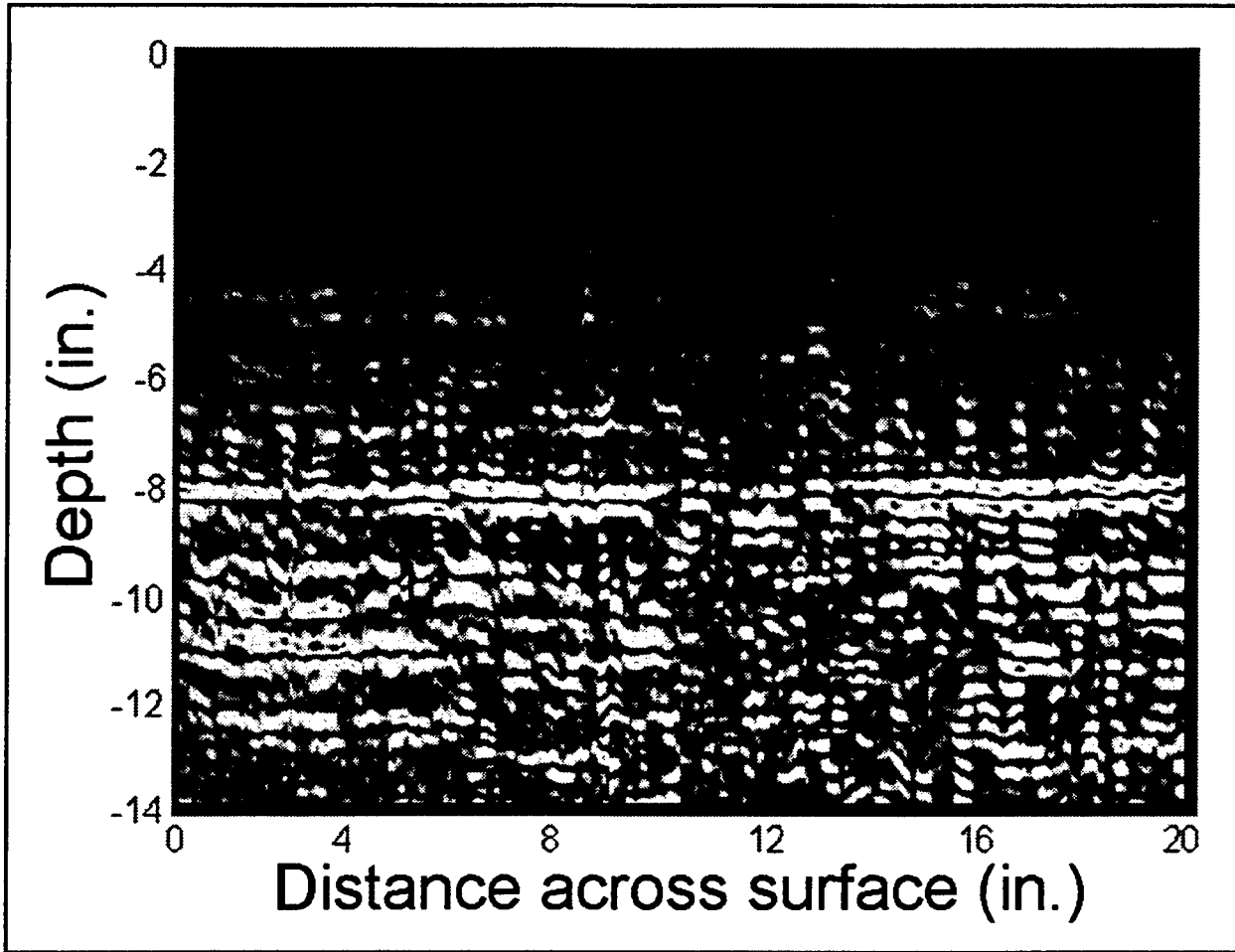

Figure 29. B-scan of laboratory floor over a soil subgrade

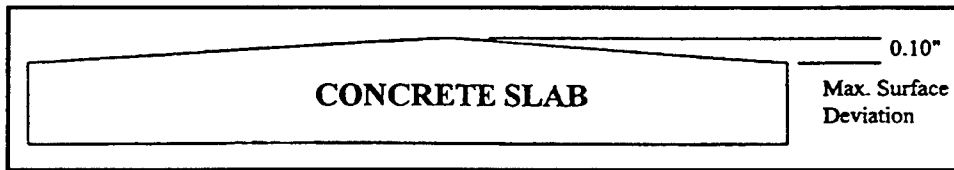

Figure 30.

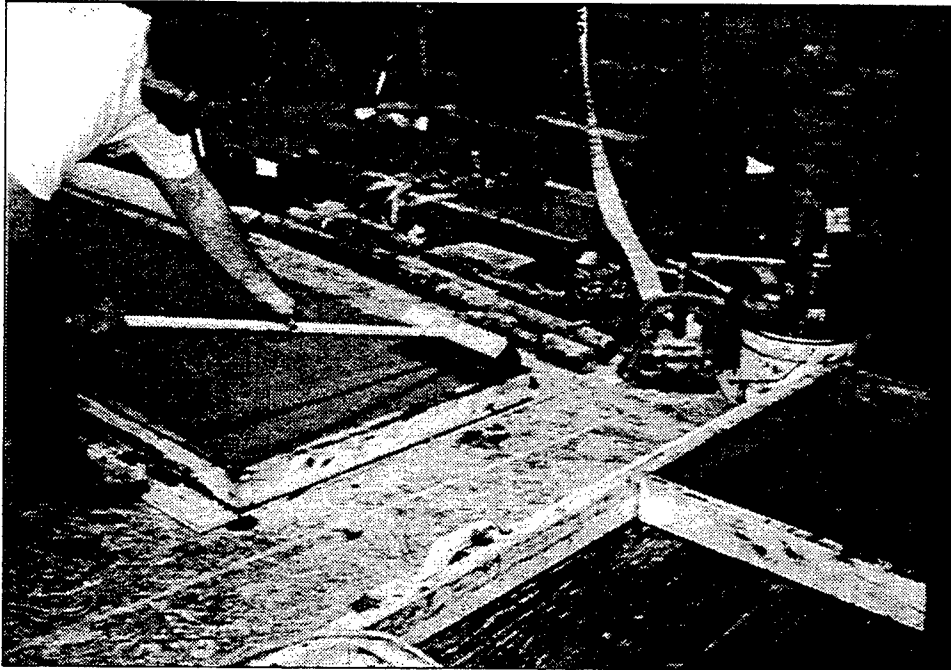

Figure 31. Transverse broom finish operation

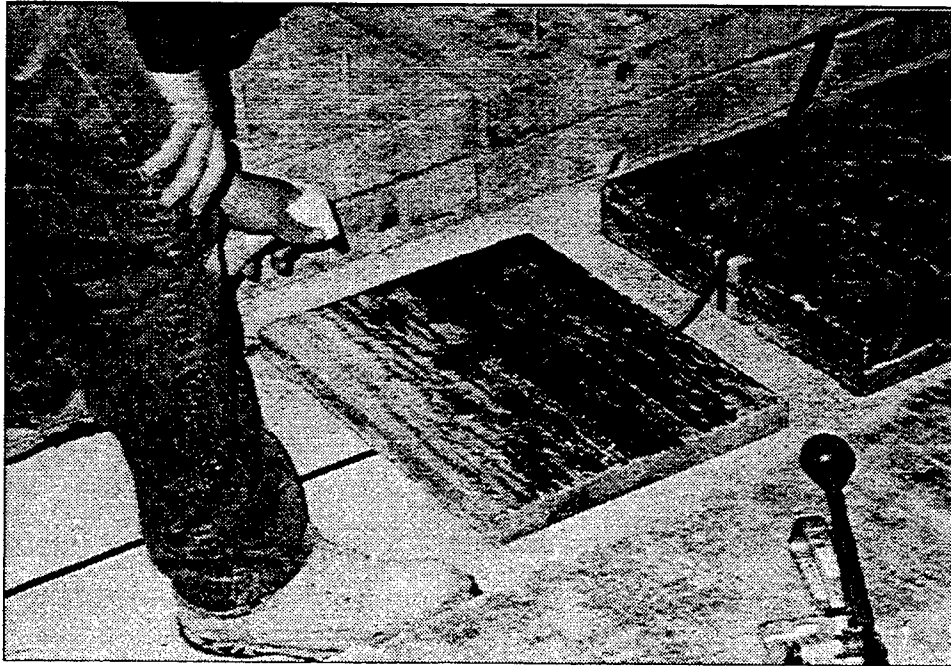

Figure 32.  $\text{CaCl}_2$  Solution sprayed on slab specimen

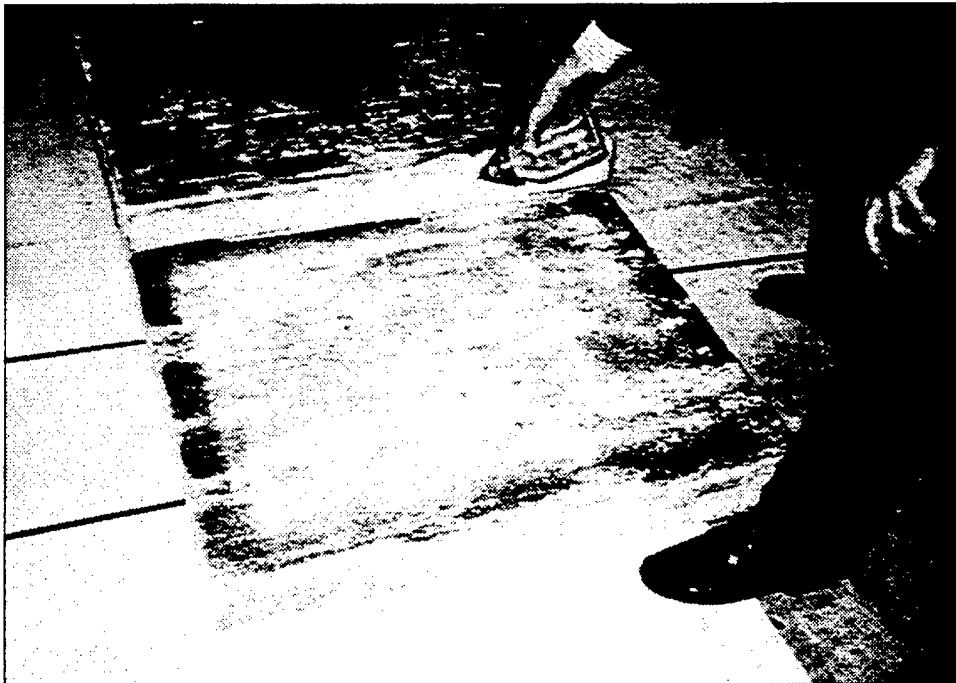

Figure 33. Debris applied on a specimen slab

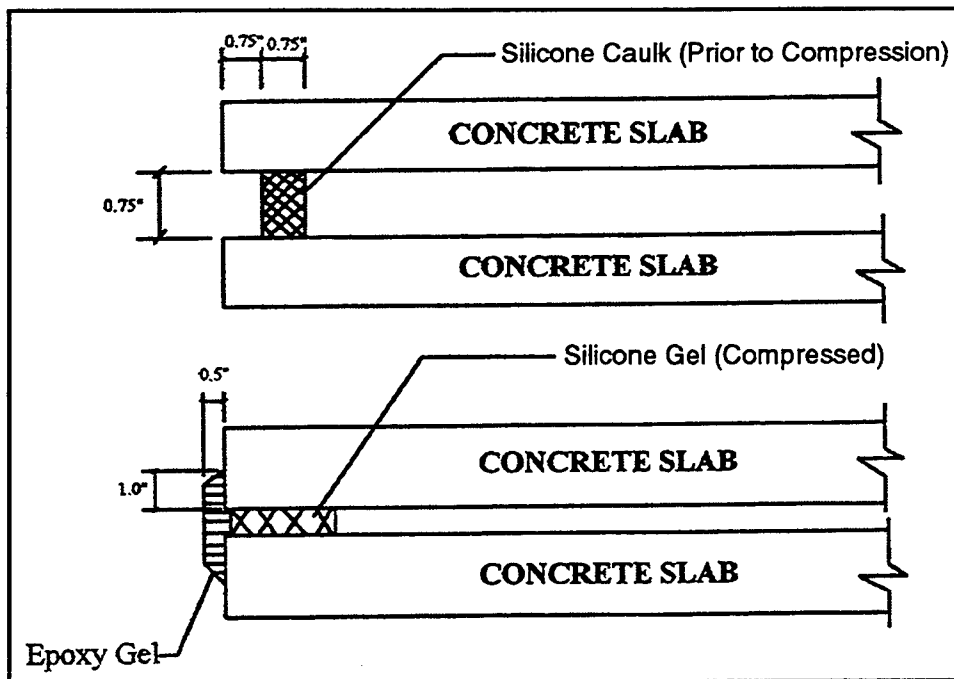

Figure 34. Assembly of slabs

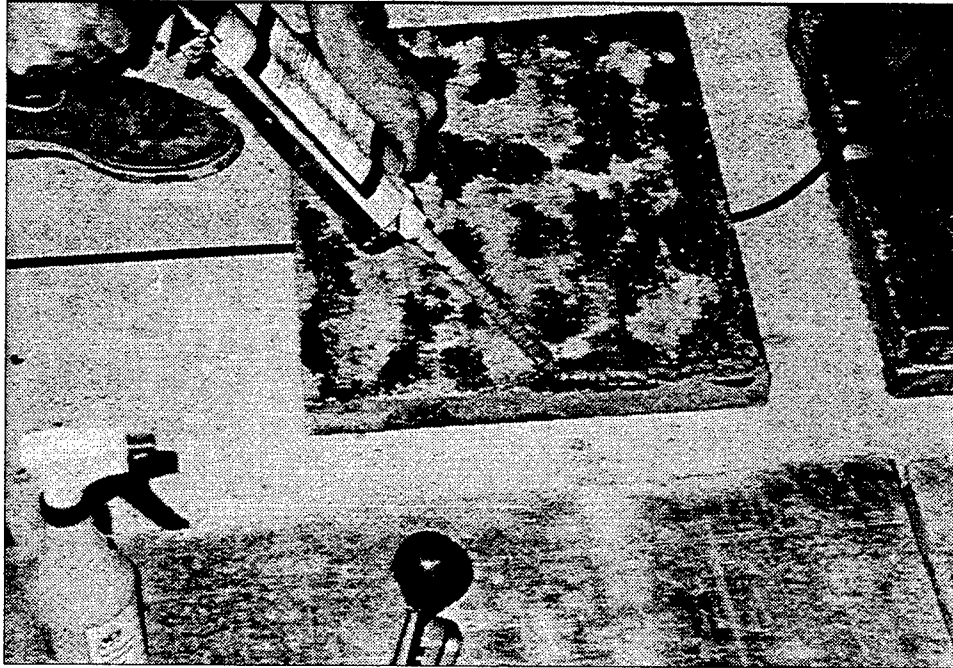

Figure 35. Epoxy seal is provided around the slab

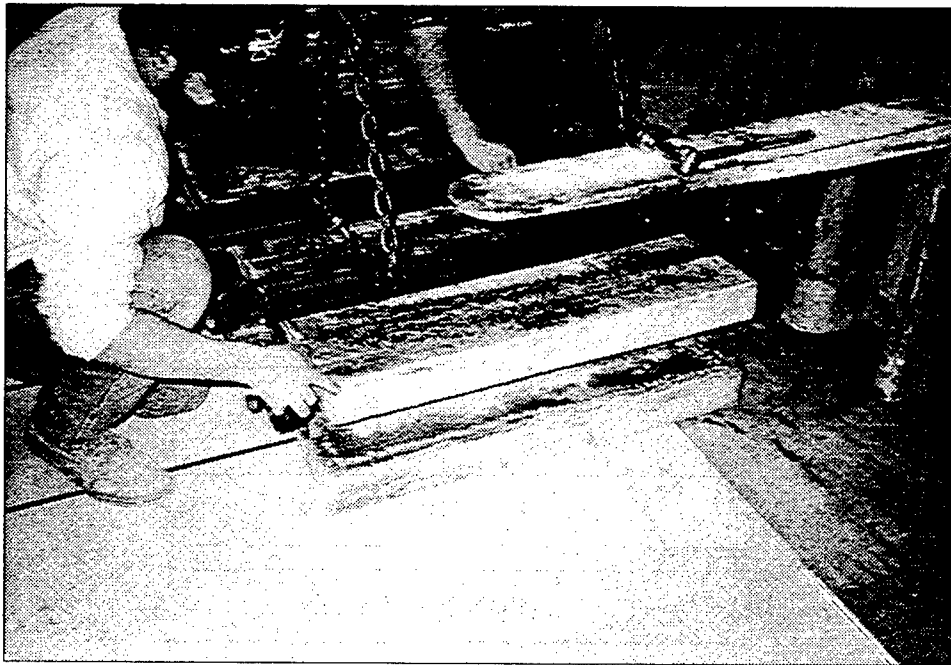

Figure 36. Top slab is placed over the bottom slab

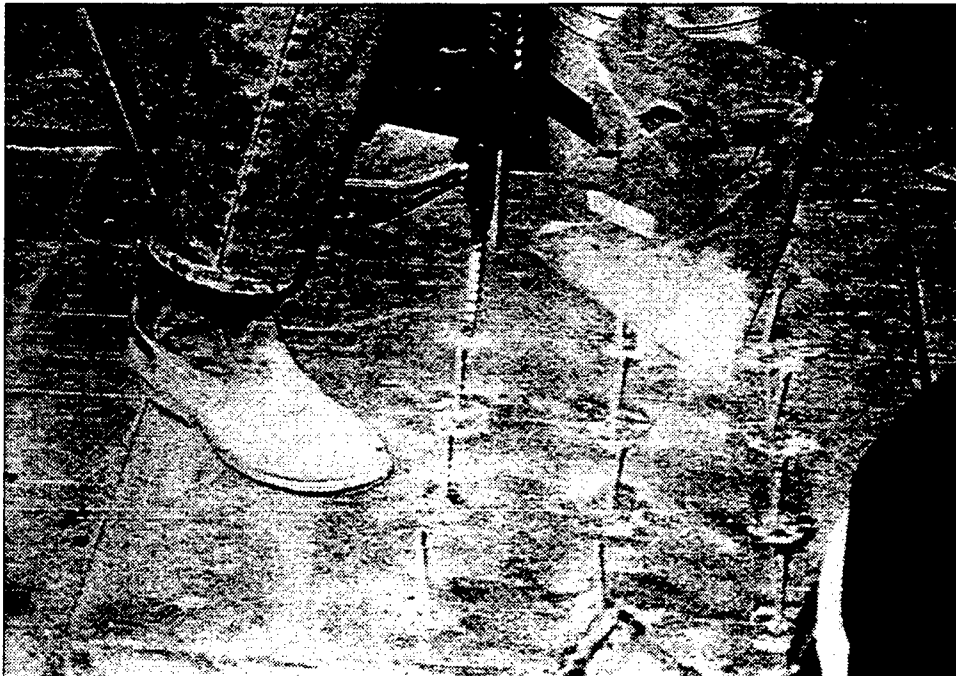

Figure 37. Drilling operation



Figure 38. Finished slab with injection ports

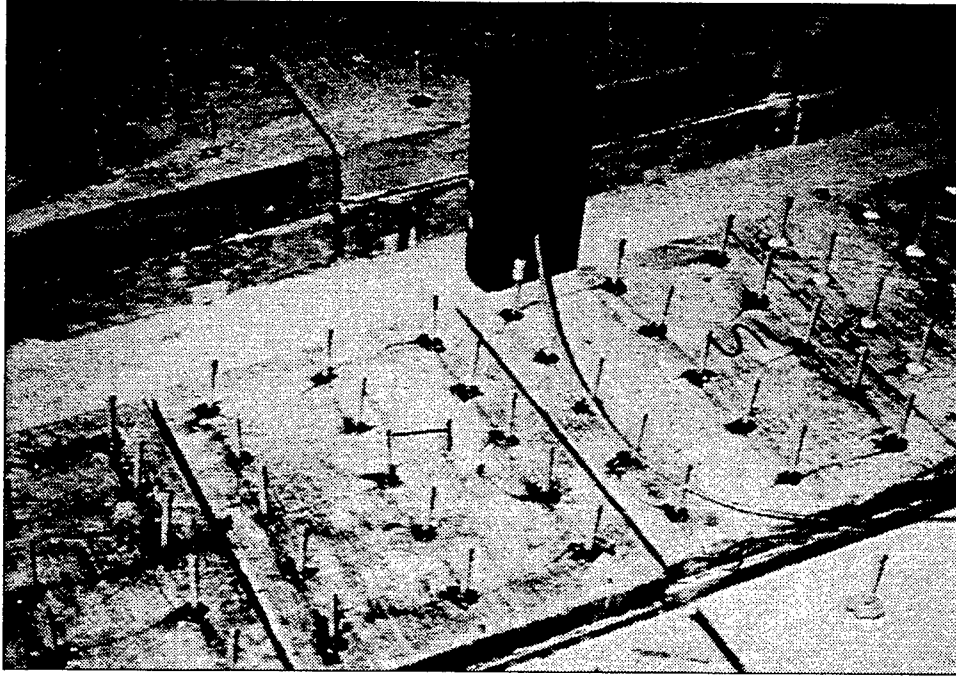

Figure 39. Polymer injection

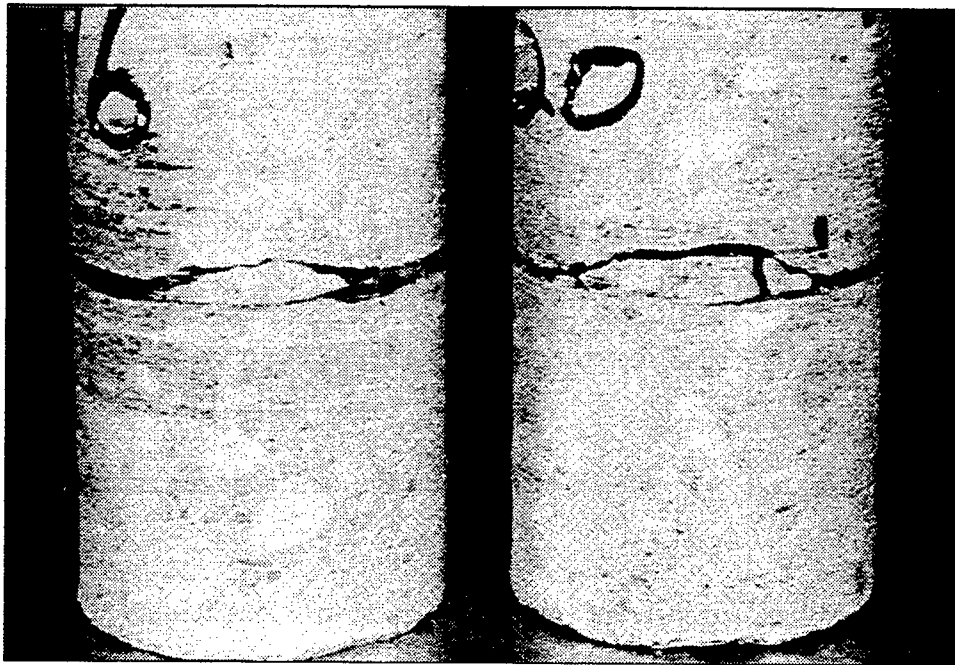

Figure 40. Core specimen from sandwich slab

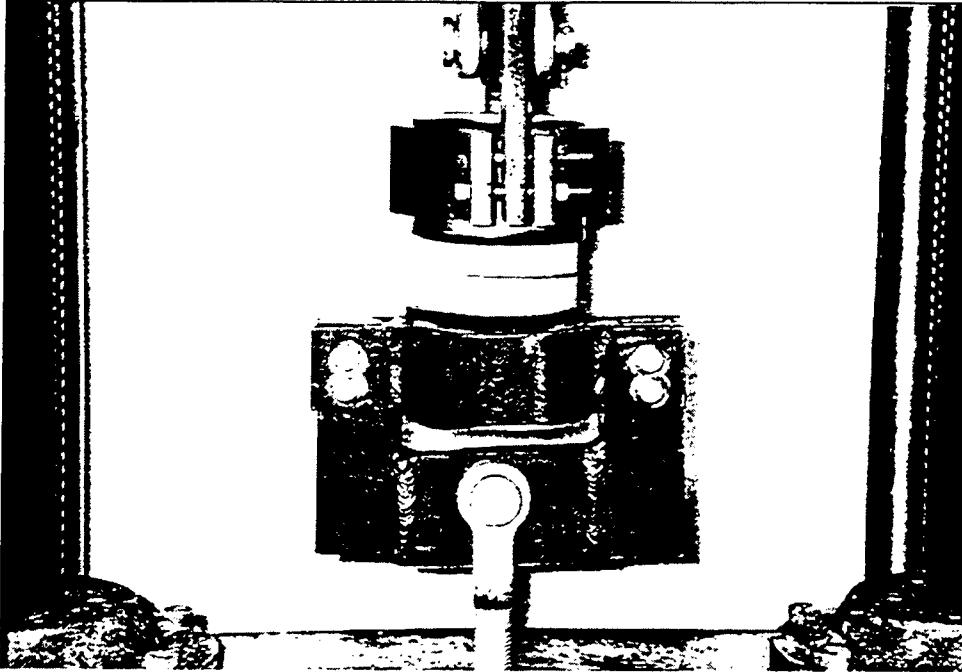

Figure 41. Direct tensile test device



Figure 42. Failed flexural test specimen

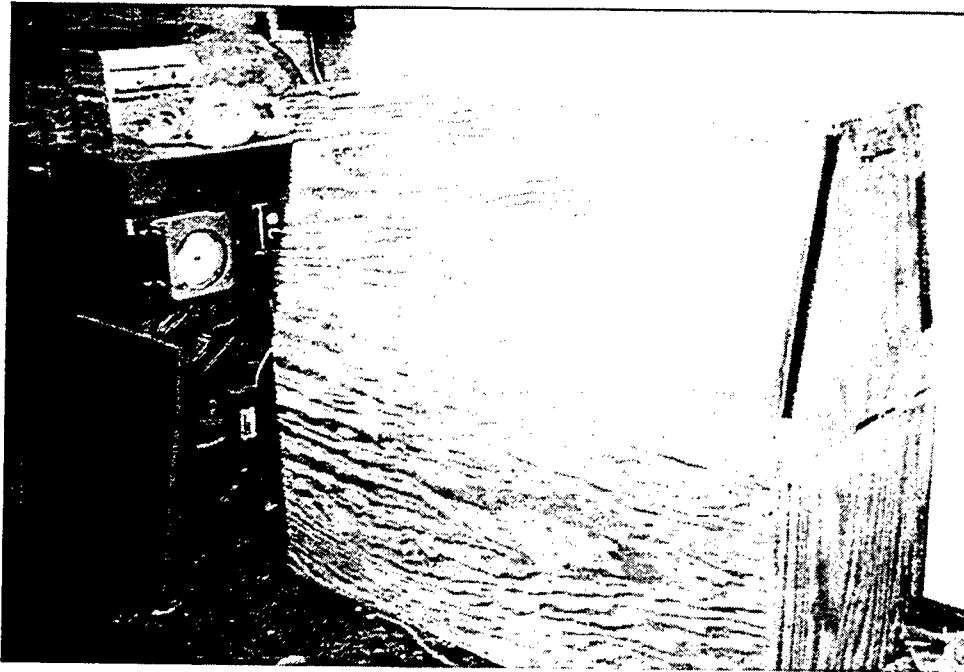

Figure 43. UV testing chamber

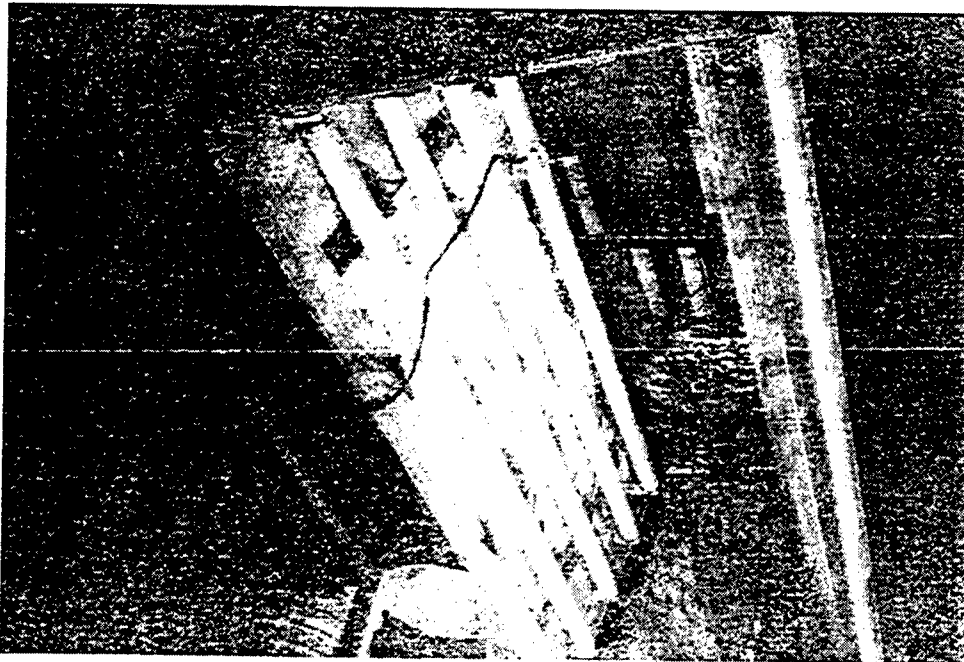

Figure 44. Top of UV testing apparatus with mounted UV bulbs

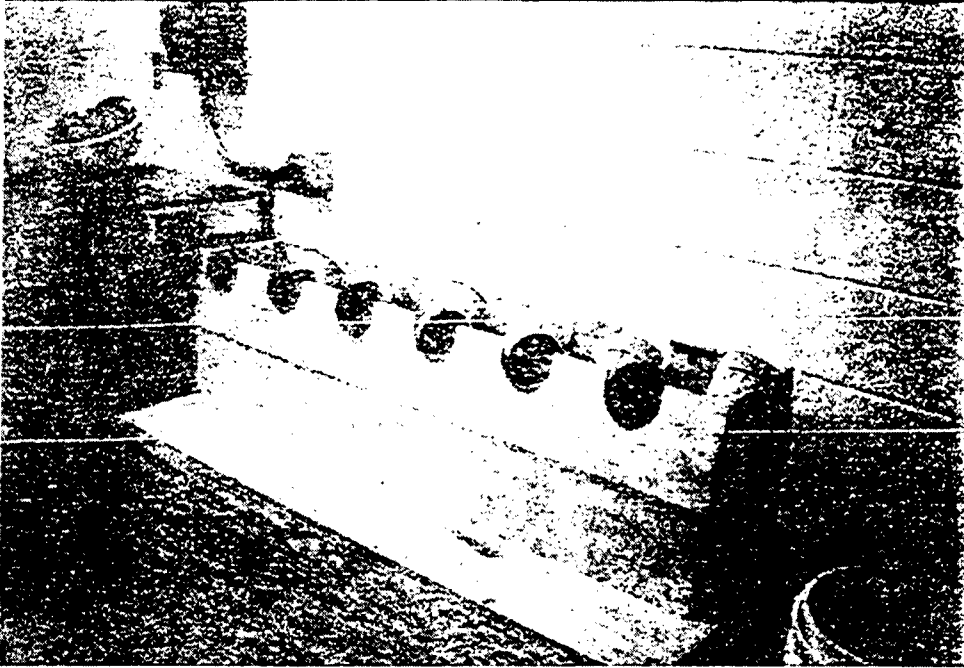

Figure 45. Cores with polymer overlay in UV testing box

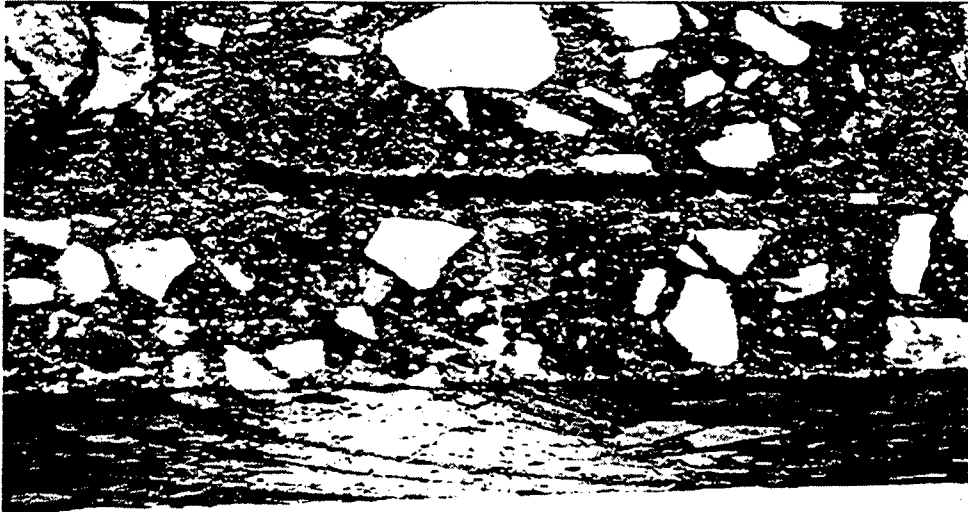

Figure 46. Failed specimen

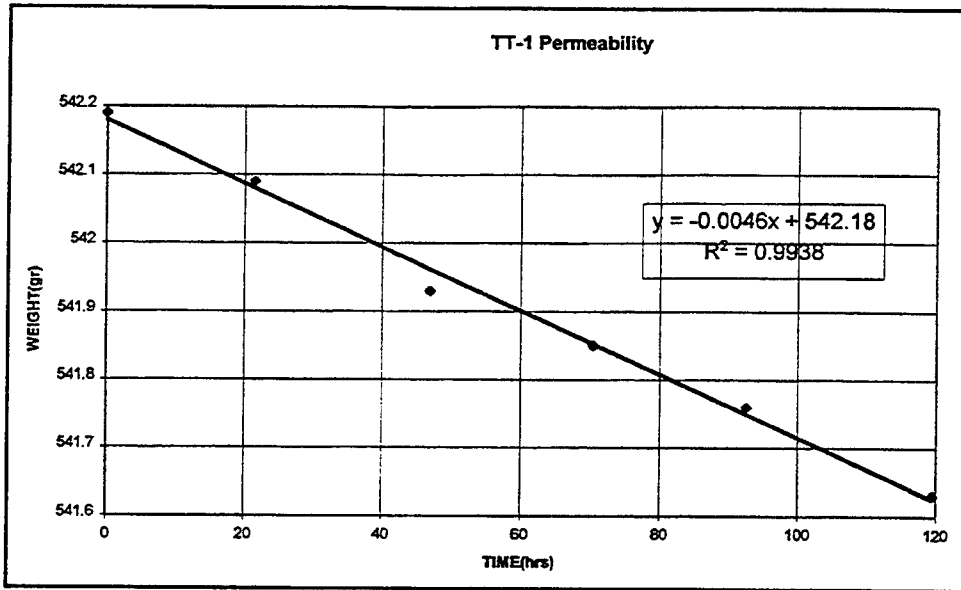

Figure 47. Permeability test results for specimen with UV exposure

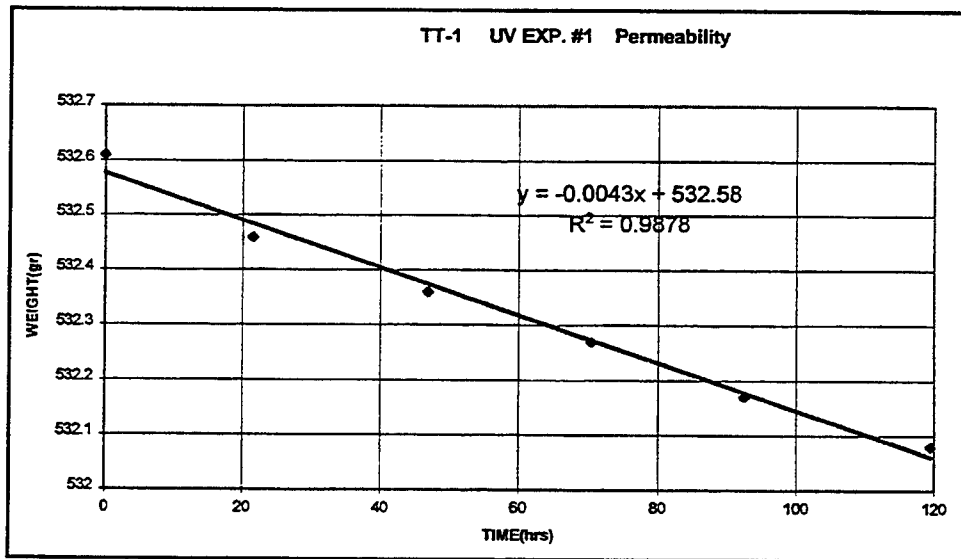

Figure 48. Permeability Test Results for specimen without UV exposure

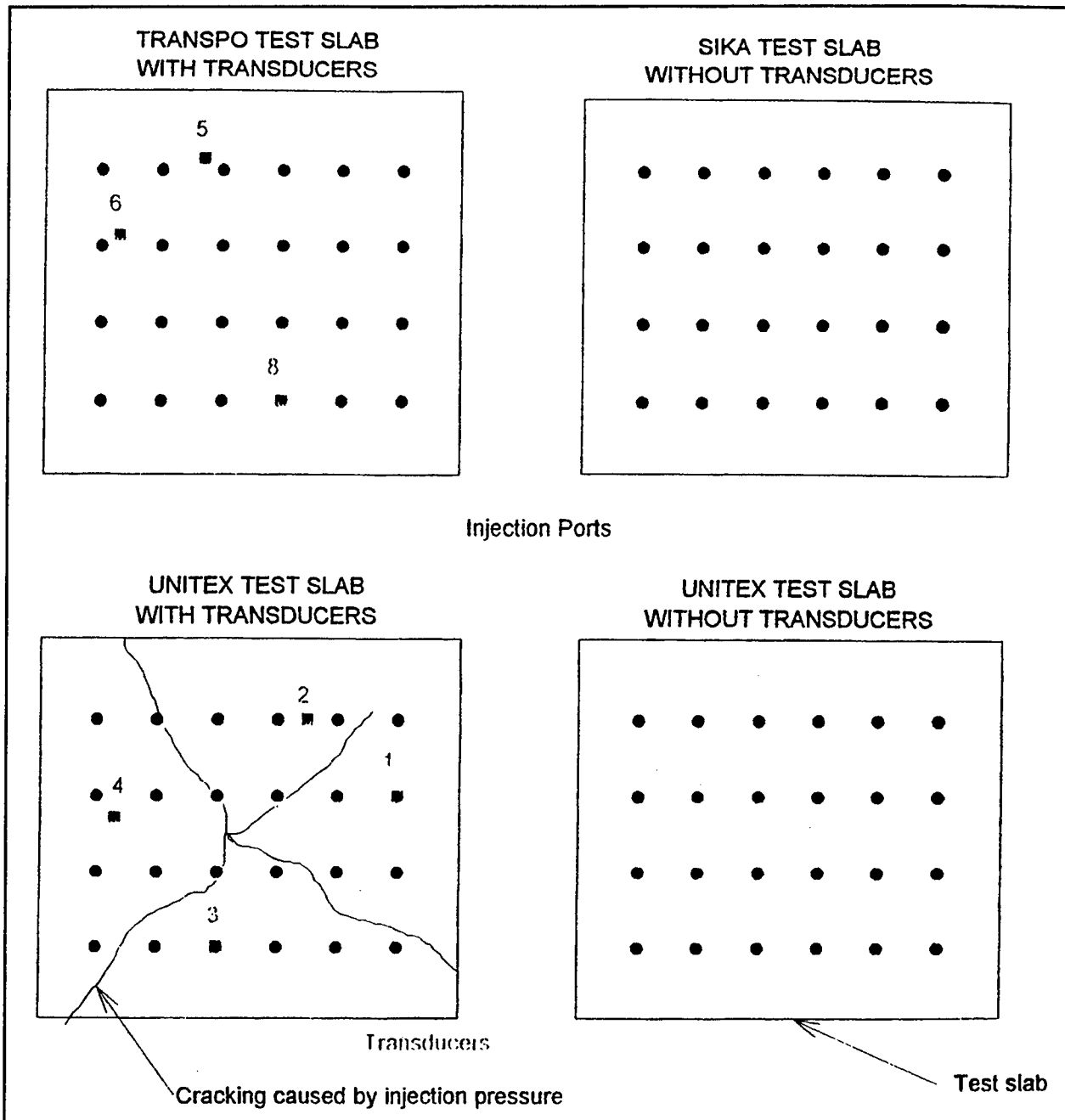

Figure 49. Test slab configuration

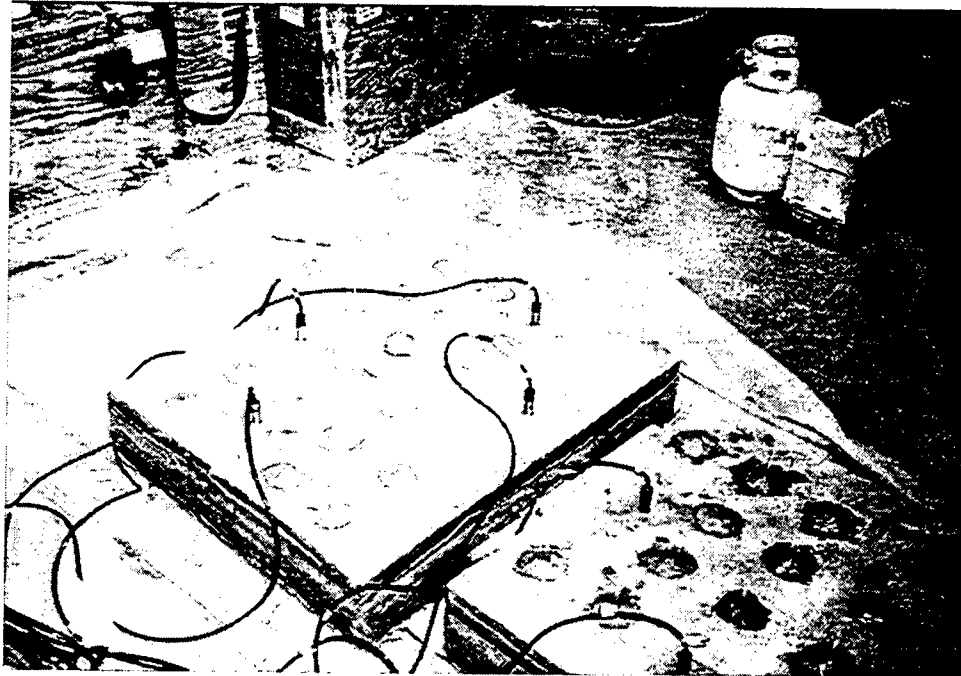

Figure 50a. Pressure monitoring system

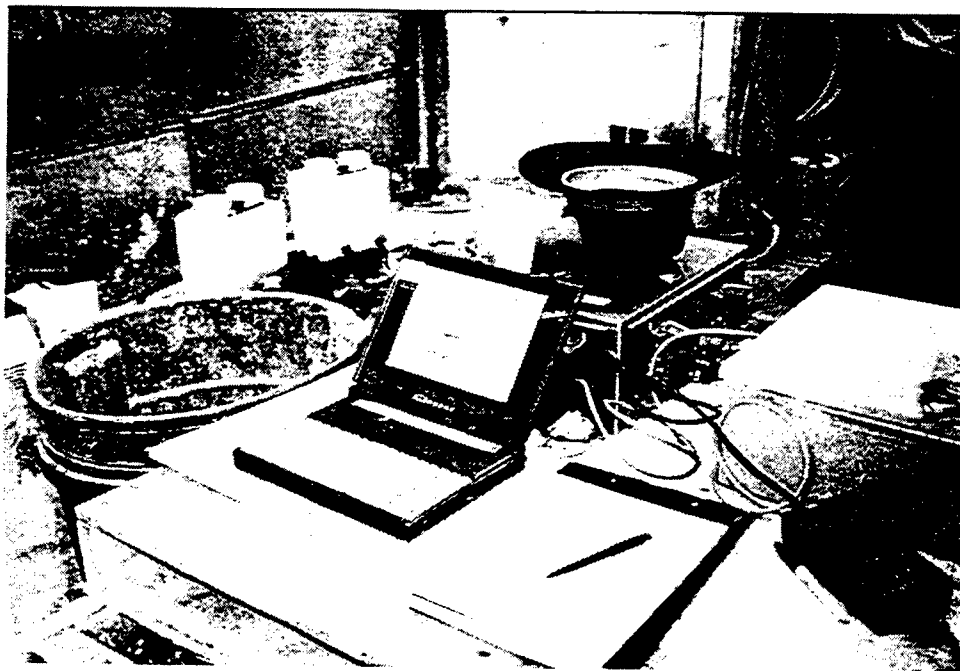

Figure 50b. Pressure monitoring system

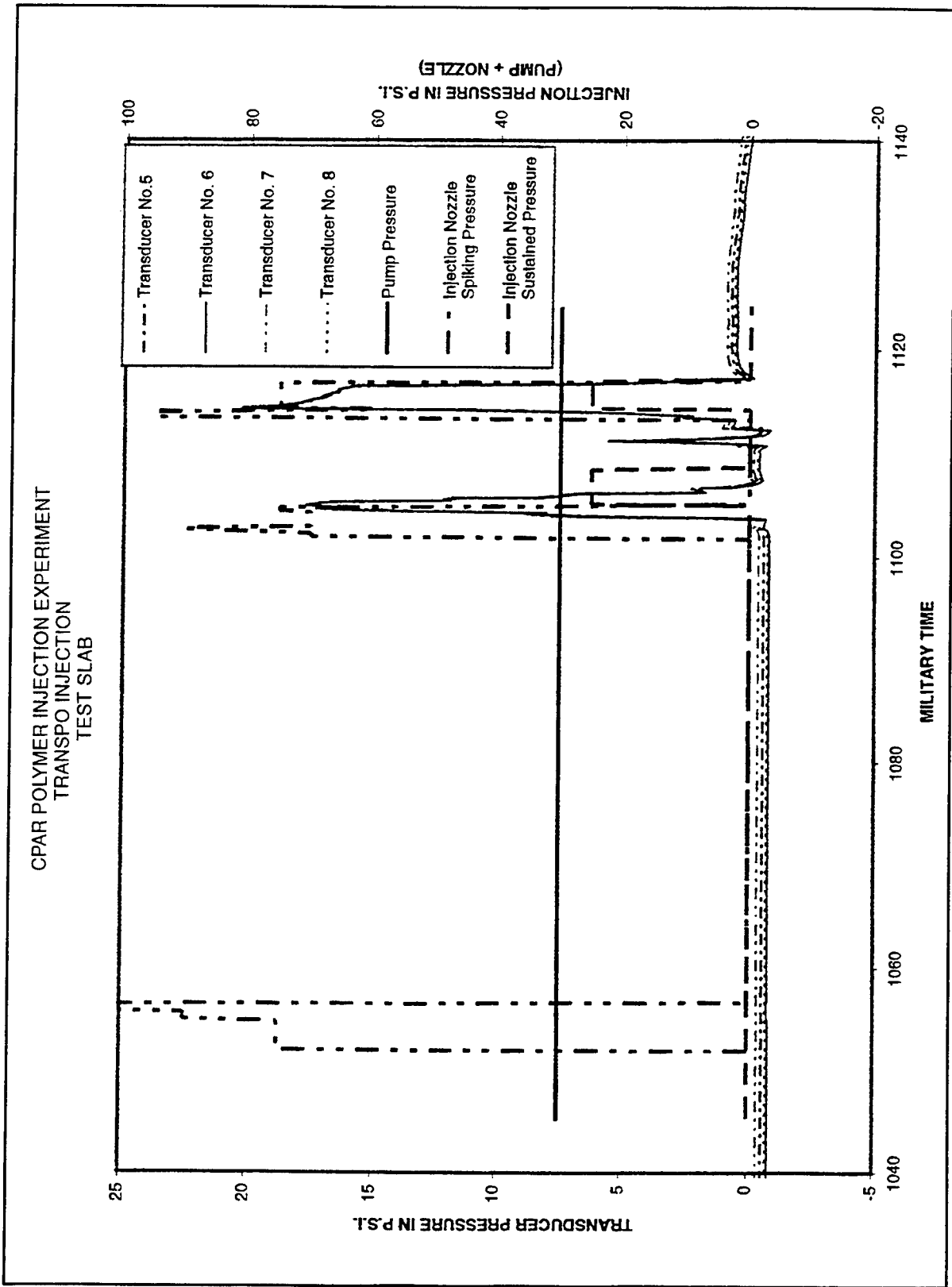

Figure 51. Transducer versus time for first slab

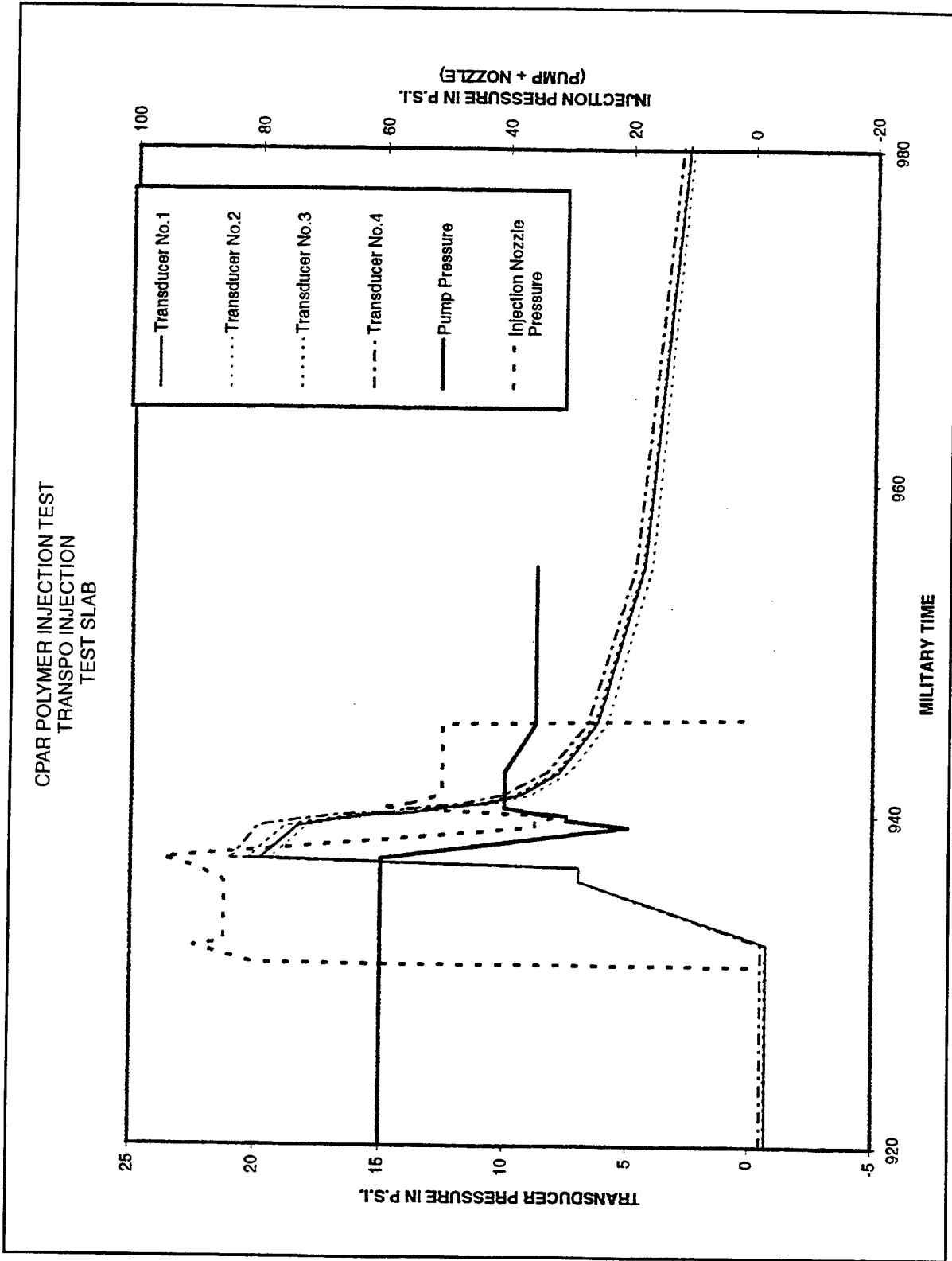

Figure 52. Transducer versus time for second slab

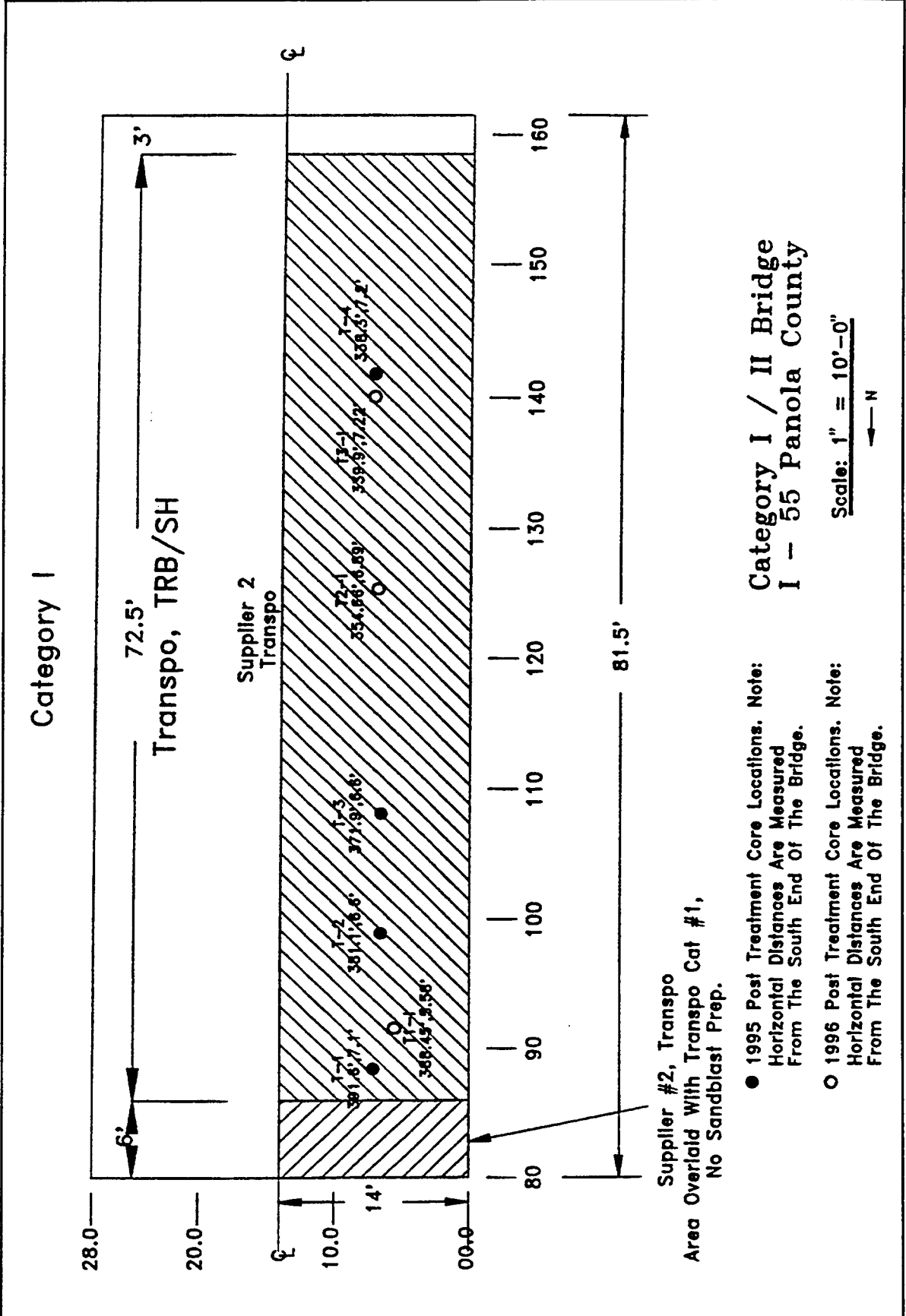

Figure 53. Mississippi Demonstration Project

# Carter Road, Cat I - 5135 S.F. Bridge 1 Mile West of Fisherville Michigan

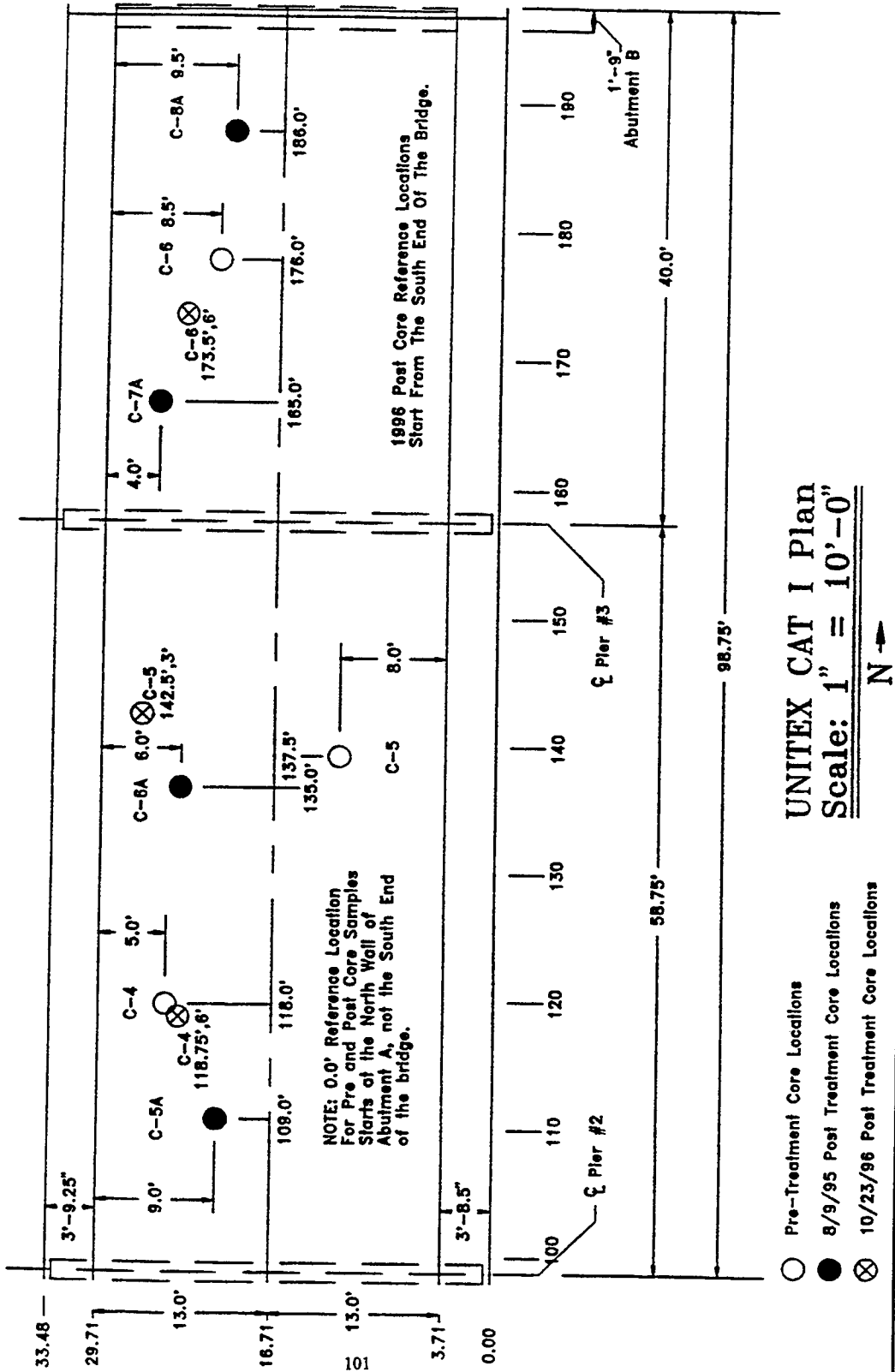
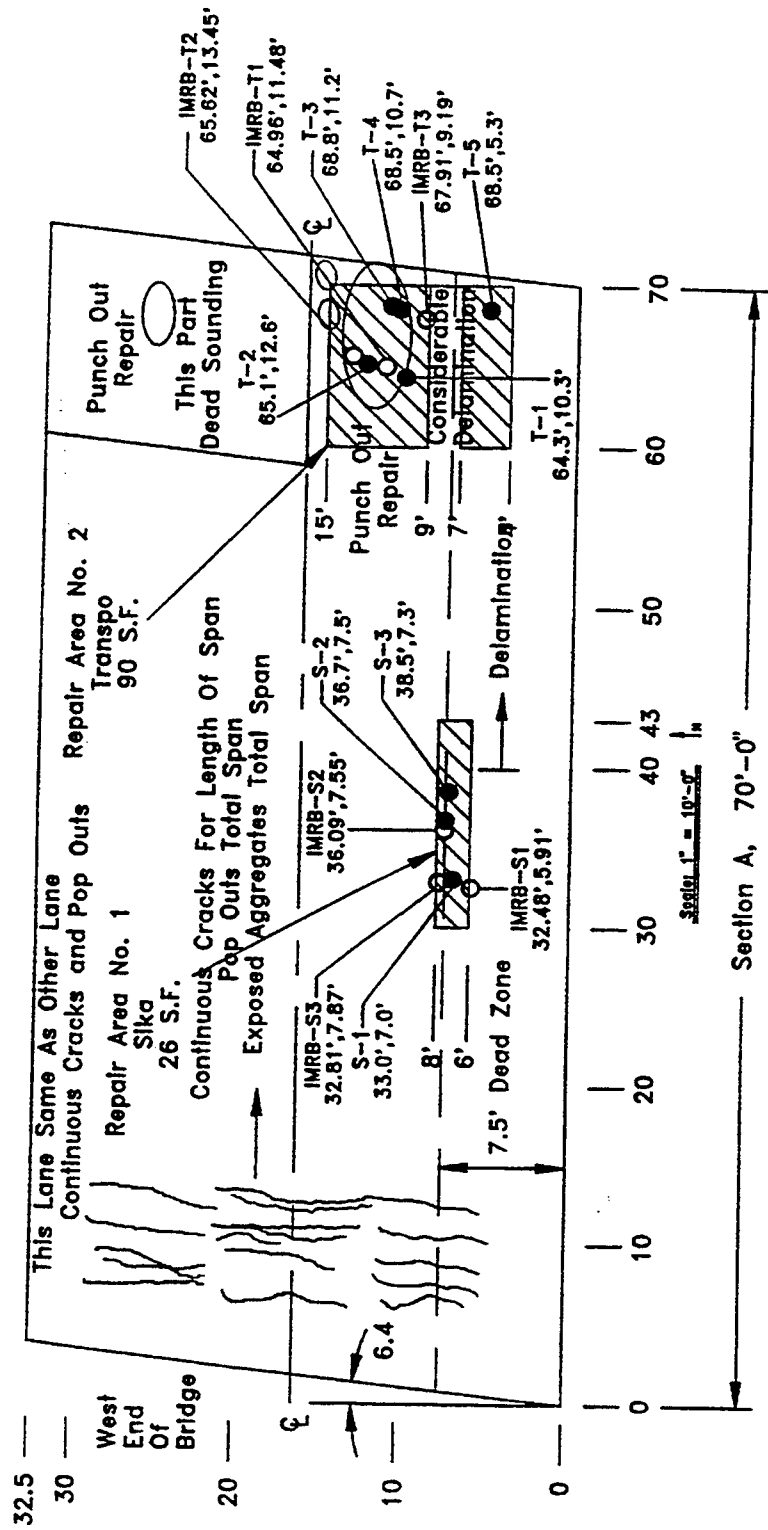

Figure 54. Michigan demonstration project



Figure 55. Finished bridge after floodcoating

Overpass At Ingrams Mill Road Over US No. 78  
 Project 79-0006-01-037-10, STA 111+09.49



● Indicates 1995 Post Treatment Core Locations  
 Note: The reference point for the horizontal stationing is the South West Corner of the Bridge.

○ Indicates 1996 Post Treatment Core Locations  
 Note: The reference point for the horizontal stationing is the South West Corner of the Bridge.

Figure 56. Mississippi demonstration project

Overpass At Ingrams Mill Road Over US No. 78  
 Project 79-0006-01-037-10, STA 111+09.49

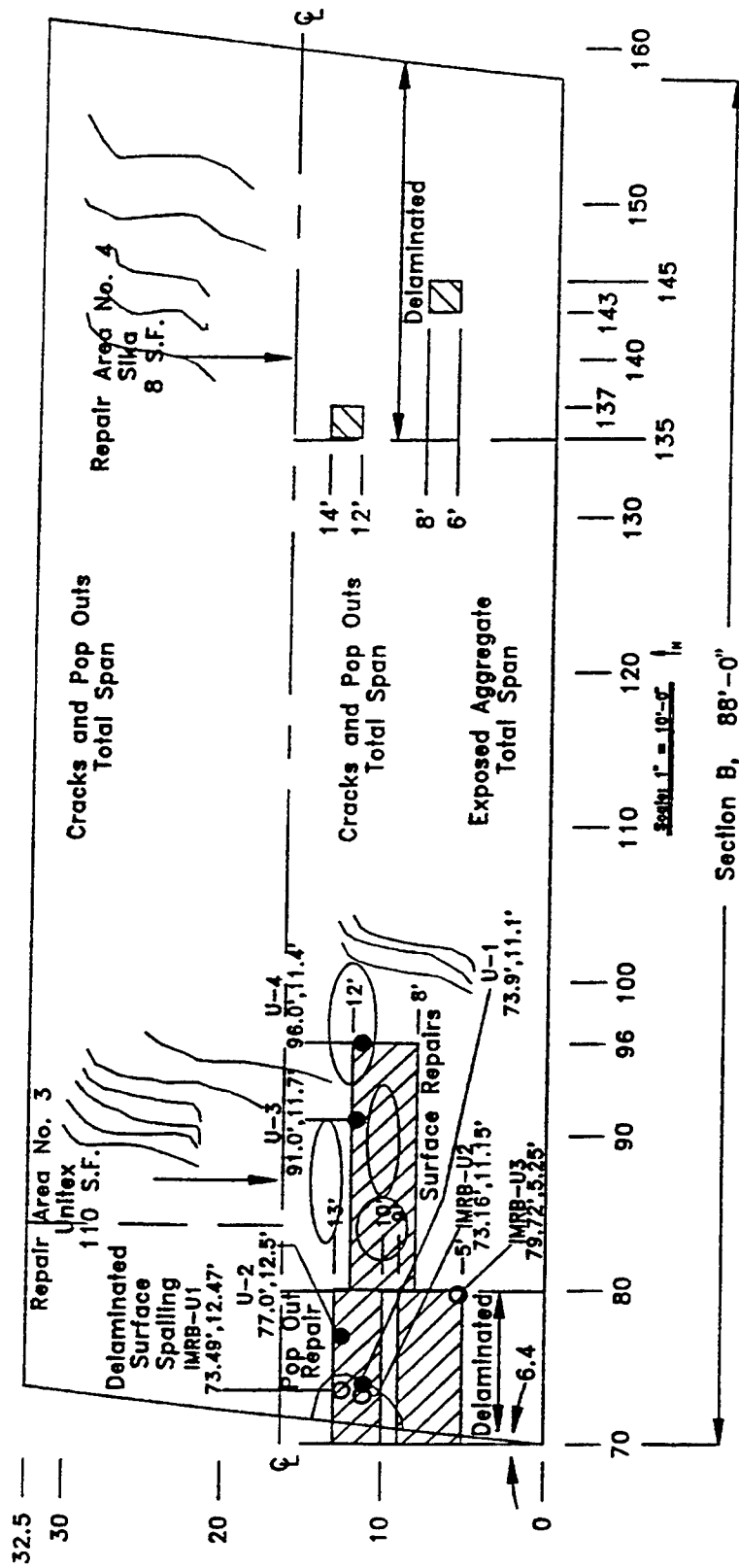

● Indicates 1995 Post Treatment Core Locations  
 Note: The reference point for the horizontal stationing is the South West Corner of the Bridge.

○ Indicates 1996 Post Treatment Core Locations  
 Note: The reference point for the horizontal stationing is the South West Corner of the Bridge.

Figure 57. Mississippi demonstration project

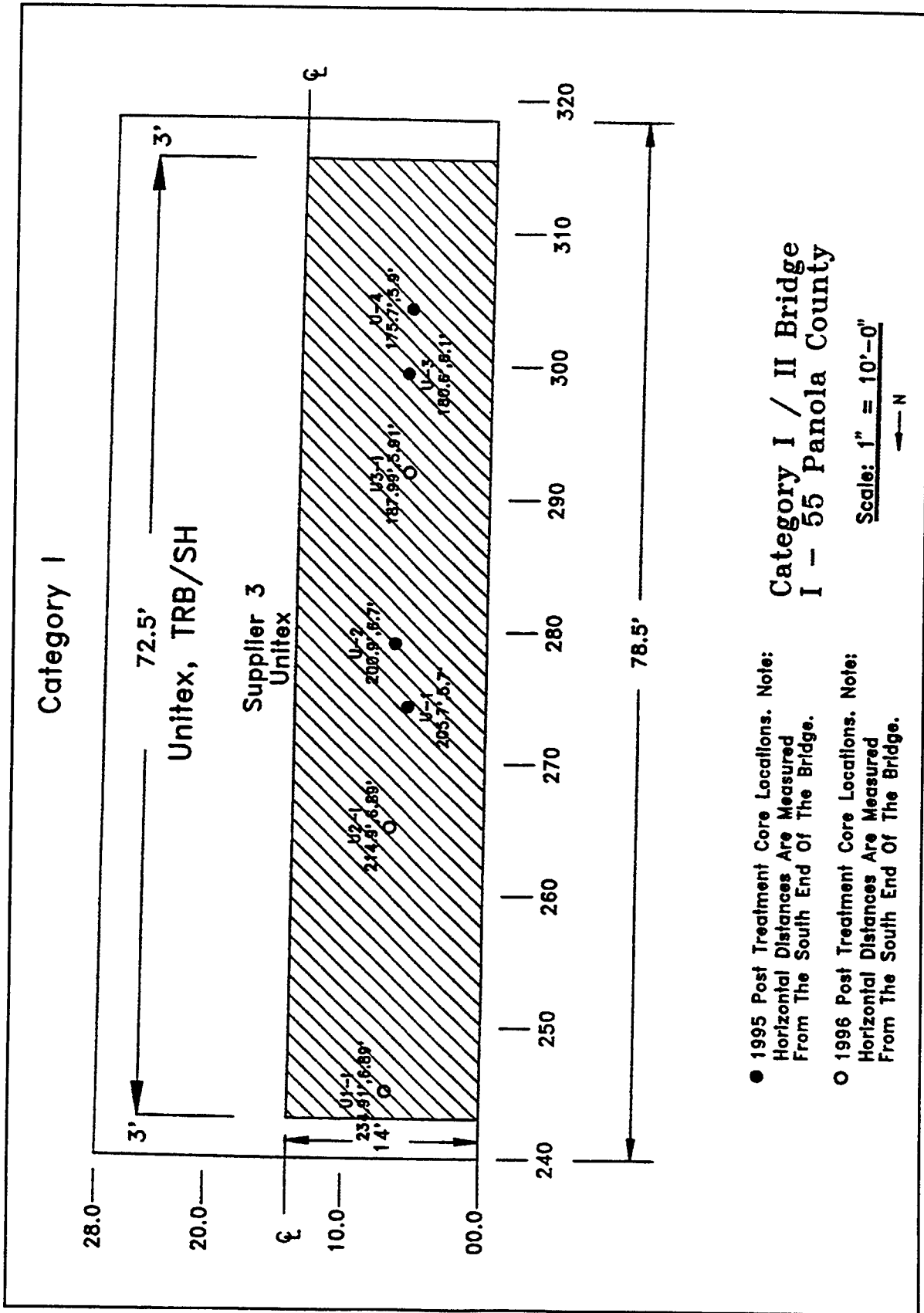

Figure 58. Mississippi demonstration project

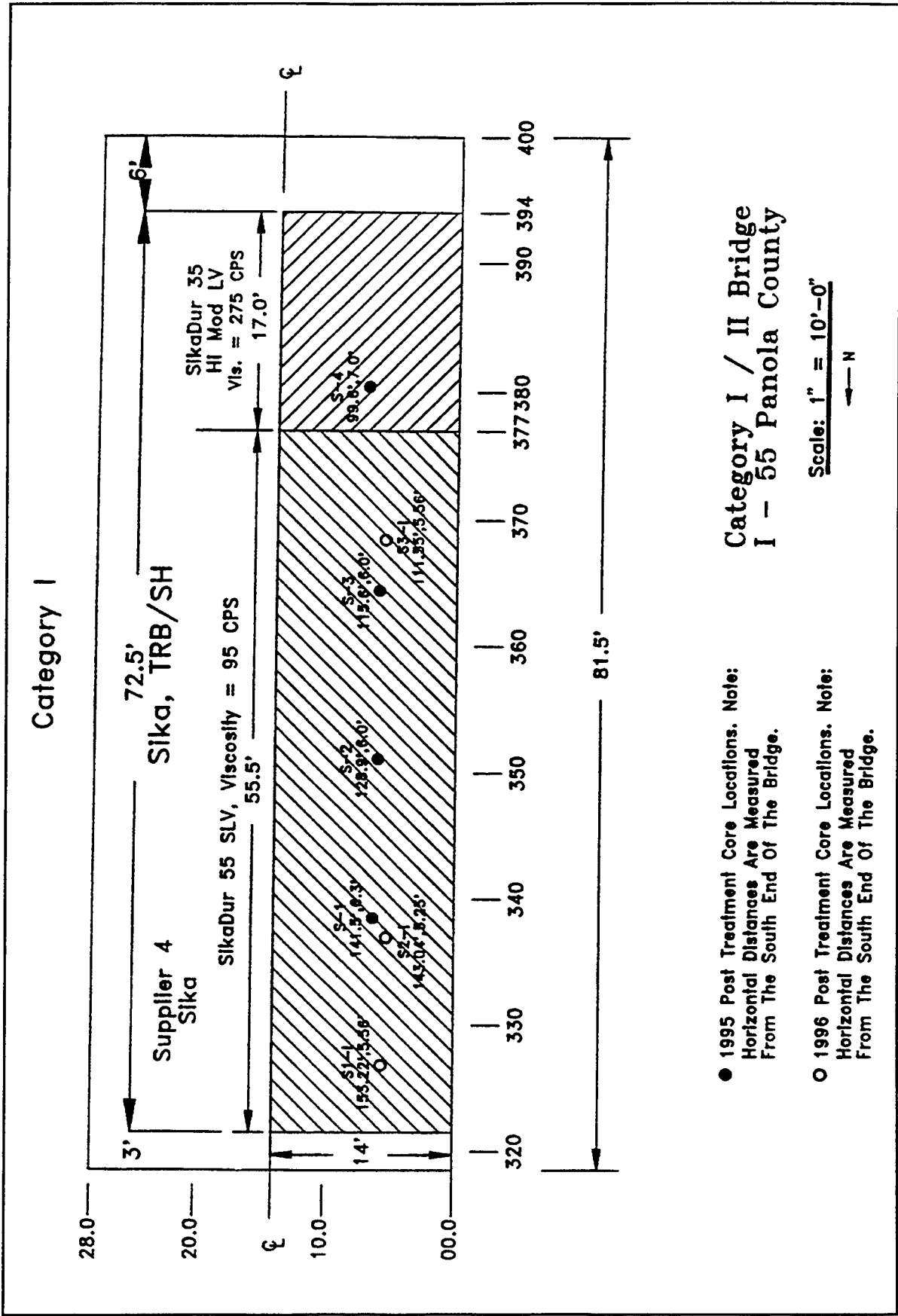

Figure 59. Mississippi Demonstration project



# Carter Road, Cat I - 5135 S.F. Bridge 1 Mile West of Fisherville Michigan

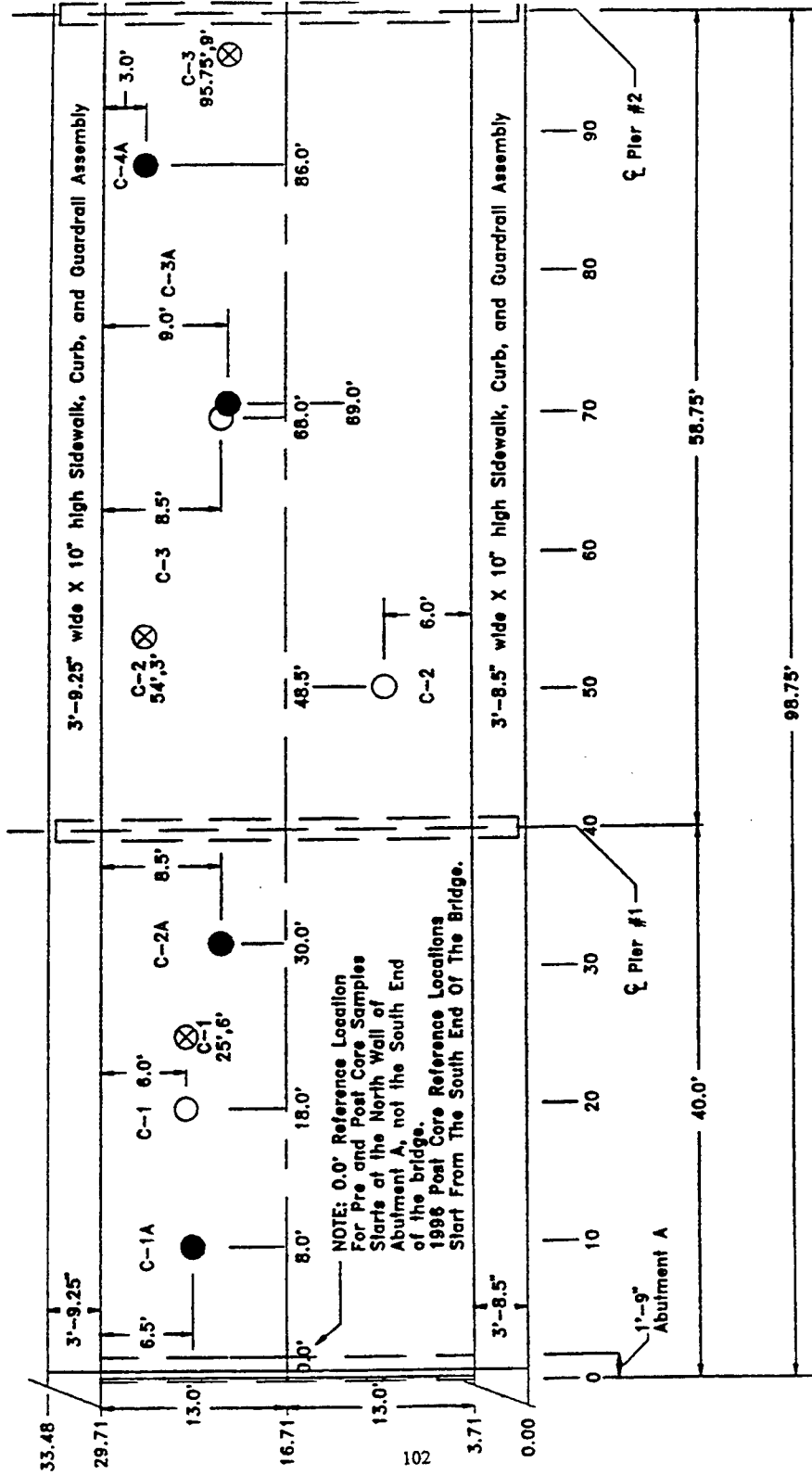

Figure 61. Mississippi demonstration project



Figure 62. Bridge surface after sand blasting



Figure 63. Injection process

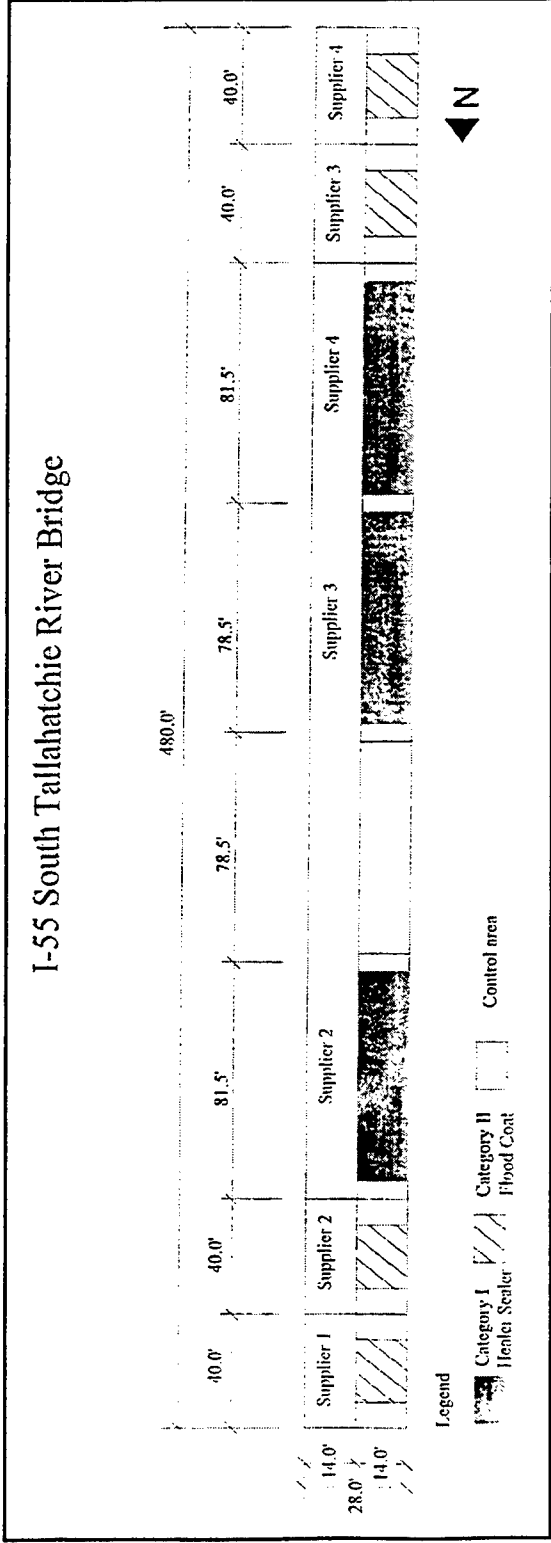

Figure 64. Layout of areas for Category-I and Category-II Overlays



Figure 65. Material placement for Category-I overlay



Figure 66. Finished Category-I overlay



Figure 67. Material placement for Category-II overlay



Figure 68. Finished Category-II overlay

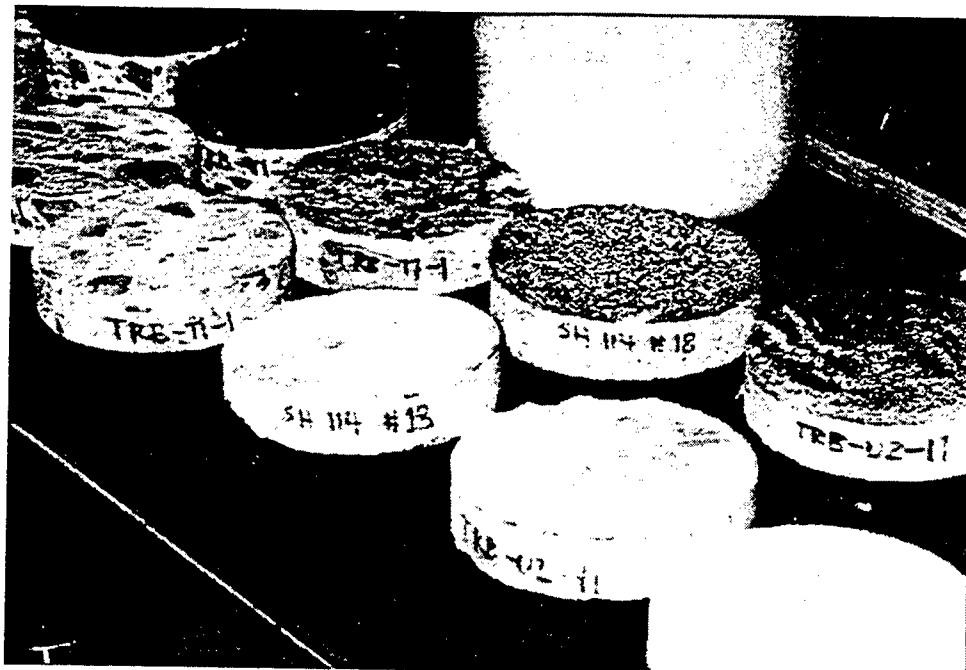

Figure 69. Post application cores for Category-II overlay

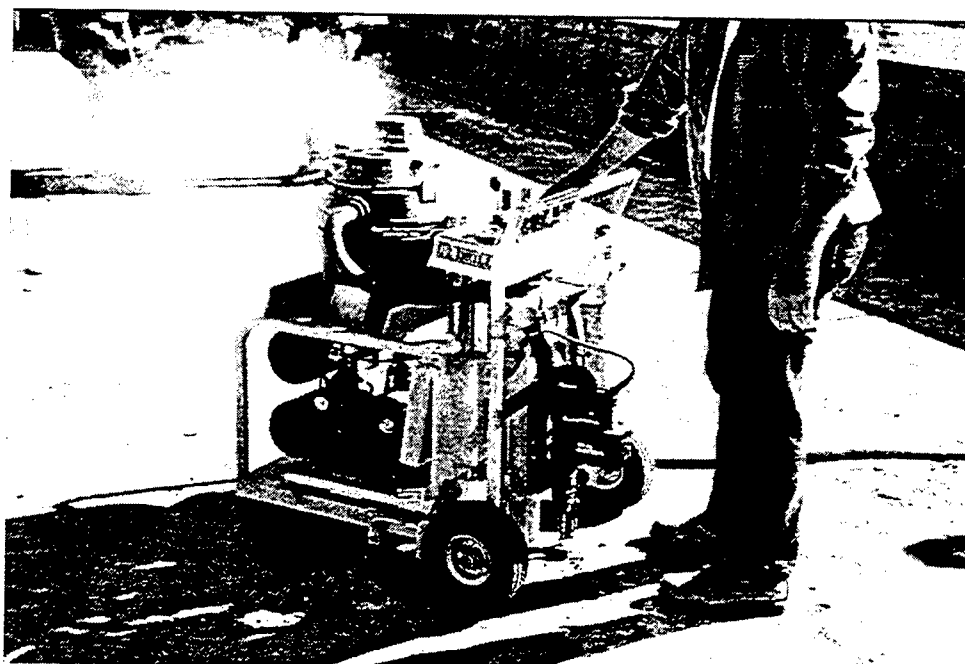

Figure 70. Drilling machine (E-Z Drill)



Figure 71. Shot blasting machine (U.S. Filter)

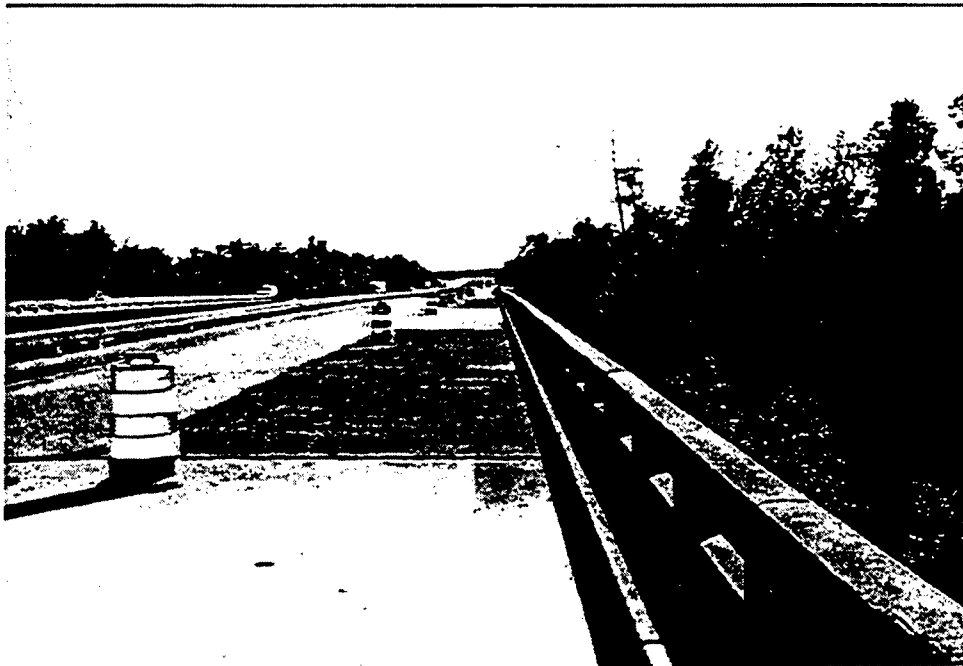

Figure 72. Finished Category-I bridge

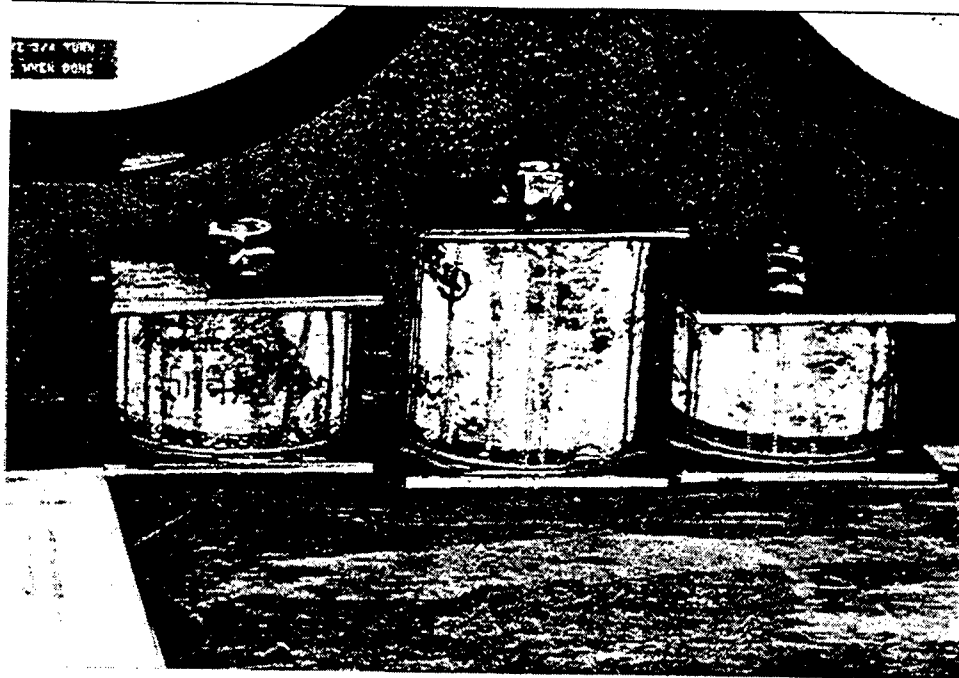

Figure 73. Tensile test specimens

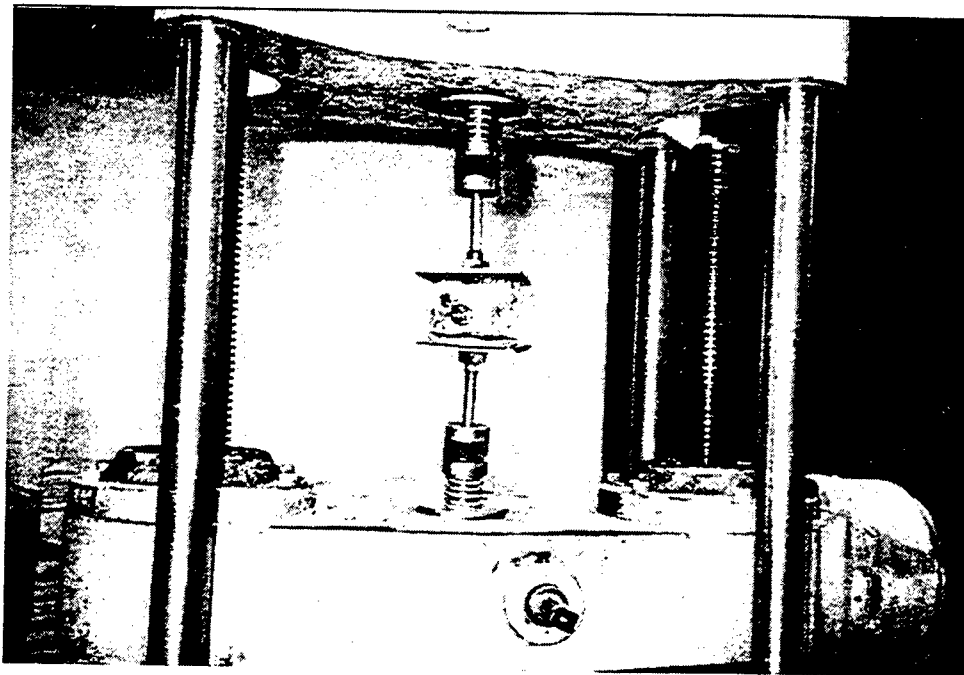

Figure 74. Tensile testing apparatus



Figure 75. Specimen after tensile testing



Figure 76. Test specimen inside dessicator

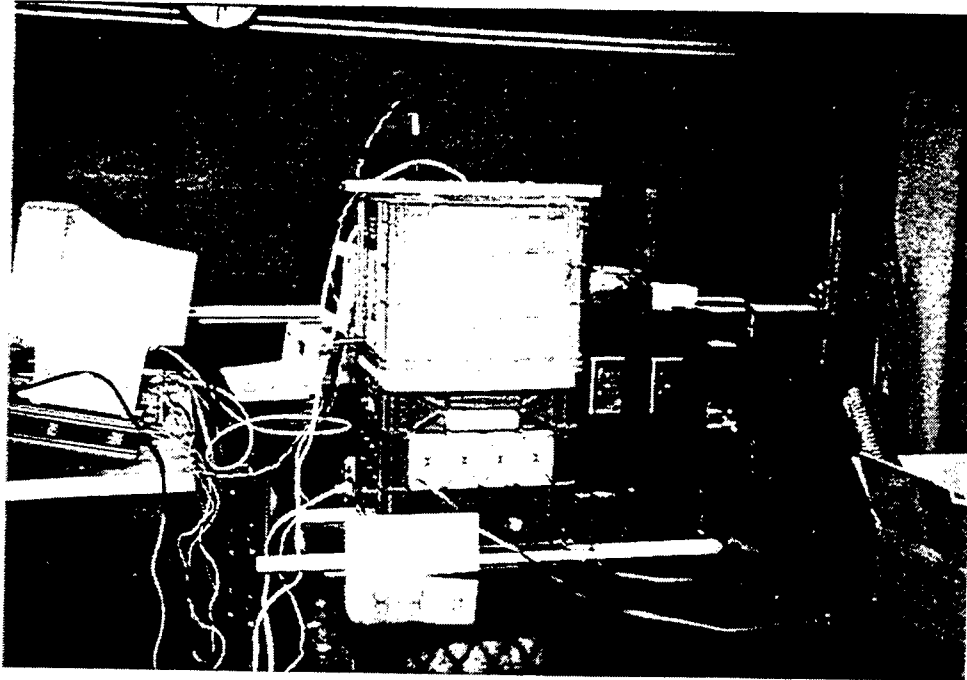

Figure 77. Temperature control box

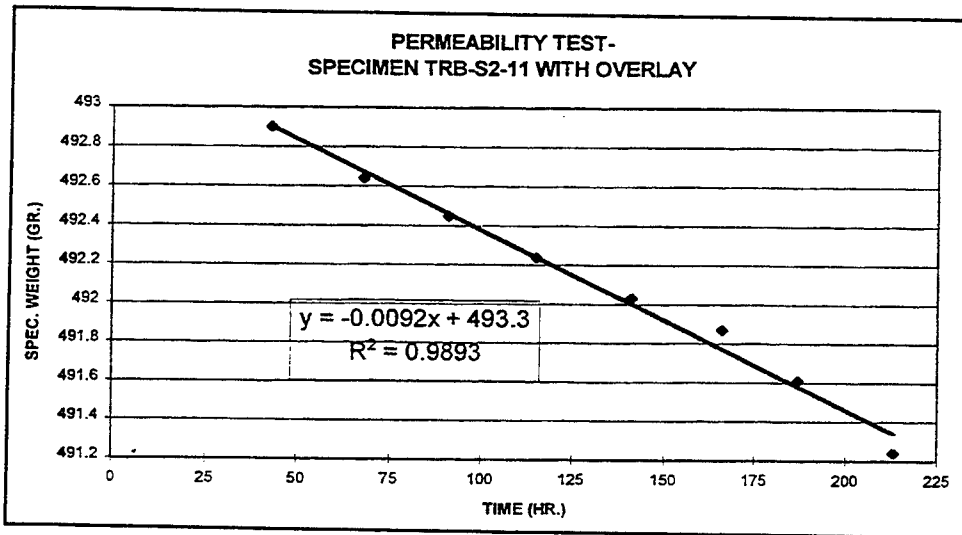

Figure 78. Permeability test results

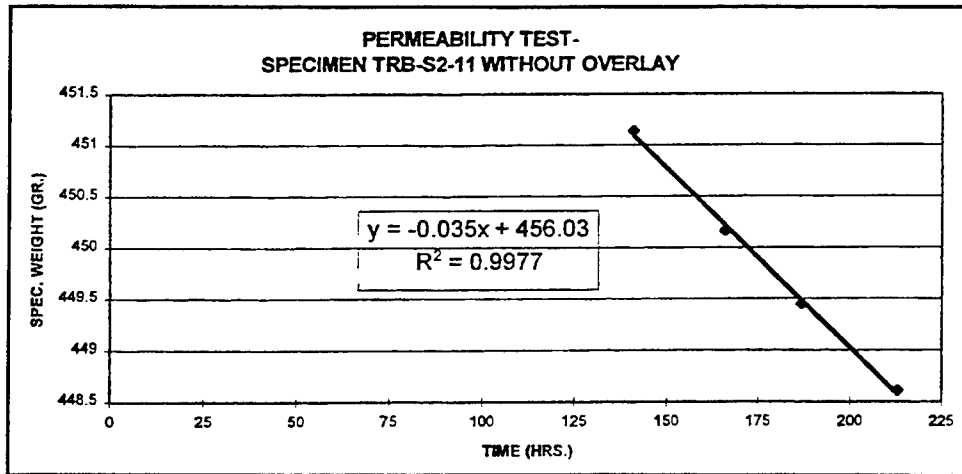

Figure 79. Permeability test results

# Appendix A

## Summary of Literature Review

---

### Defects Versus Current Repair Methods

Repair of concrete and reinforced concrete structures consists of recovery of concrete strength and uniformity in defective areas of these structures. The cause of bridge deck defects can be divided into three groups: high-porosity concrete, cracks, and volume defects (delaminations, spallings, etc.). Various treatment methods are recommended according to this classification of defects. For a new bridge deck and its high-porosity concrete, an impregnation, sealing, or thin overlay method should be applied. Once concrete cracks or delamination appears, the polymer-injection method should be used before the deterioration worsens. When a bridge-deck deterioration is in its final stage (volume defects), sealing or patching with low-viscosity polymerizing compositions should be considered before the decision is made to replace the bridge deck.

All of the maintenance options listed below involve either controlling the main sources of concrete-deck problems (salt and water) or attempting to extend the time between the start of corrosion of the reinforcing steel and the costly eventual result, spalling. After the type and extent of damage have been determined, a selection of the type of repair must be determined, which can be summarized in detail as follows:

- a.* Repair of localized damaged areas by surface patching or the injection of bonding materials into hollow planes or cracks.
- b.* Repair with membrane and bituminous covers for minor surface conditions. This should also retard the development of more damage.
- c.* Thin bonded-concrete overlay or other type of bonded overlay.
- d.* Replacement of the entire deck.

An identification of deck treatments used by states was accomplished through a review of the literature (Babaei and Hawkins 1987<sup>1</sup>; Carter 1989; Sprinkel 1992, 1991, 1993; Sprinkel, Weyers, and Sellars 1991; Sprinkel and Weyers 1993; Tracy and Fling 1989; Vaysburd 1993). The treatments identified by that review are shown in Tables A1 and A2. The protection methods most frequently used are asphalt overlays on membranes, polymer overlays, and sealers. They are more frequently used on newer bridge decks than on old ones. The repair methods most frequently used include asphalt concrete overlays with and without membranes, crack repair and sealing, high-early-strength hydraulic-cement overlays, polymer overlays, and patching methods.

## Sealers

Sealers are placed on bridge decks and other concrete surfaces to reduce the infiltration of chloride ions and water (Carter 1989). The materials can usually be applied by spray, roller, brush, or squeegee. Organic and inorganic sealers that have been used on decks include acrylic, epoxy, gum resin, rubber, urethane, silicone resin, silane, and siloxane, all of which act as pore blockers once the solvent carrier evaporates. Silanes react with moisture under alkali conditions to form a silicone resin film. Siloxanes are a combination of silane and silicone polymers. Silicates react with the calcium in concrete to form a tricalcium silicate film after evaporation of the water carrier. Sealers with a 100-percent solids content that have been used on bridge decks include acrylic, high-molecular-weight methacrylate, hydraulic cement, epoxy, and rubber.

It is usually not practical to repair and seal randomly oriented cracks, such as plastic shrinkage cracks, with methods other than gravity fill polymers such as high-molecular-weight methacrylate and low-viscosity epoxies. To fill plastic shrinkage cracks, the deck is usually flooded with monomer. The monomer is brushed into the cracks until they are filled. When deck surfaces do not have a tined texture or saw-cut grooves, aggregate is broadcast onto the monomer to provide adequate skid resistance.

To provide adequate skid resistance, sealers (particularly those with a high solid content) must be placed on heavily textured surfaces. Satisfactory textures to which sealers can be applied can be obtained by tining the fresh concrete, by shotblasting the hardened surface, or by sawcutting grooves 0.13 in. (3.3 mm) wide by 0.13 in. (3.3 mm) deep by approximately 0.75 to 1.5 in. (19 to 38 mm) on centers in the hardened concrete. The deck must be patched prior to placement of the sealer, and the patching materials must be compatible with the sealer. Also, the patching material must be cured sufficiently, usually a minimum of 28 days, so that moisture in the patch or gas produced by

---

<sup>1</sup> References cited in this appendix are located at the end of the main text.

chemical reactions does not interfere with the penetration or adhesion of the sealer.

## Membranes

Membranes that are used include polymer binders filled with aggregate similar to multiple-layer polymer overlays, prefabricated sheets placed on a mastic, and liquid-placed membranes. The membranes usually extend 1 in. (25 mm) up faces of curbs, across backwalls, onto approach slabs, and across all joints except expansion joints.

<b>Table A1 Bridge-Deck Protection Methods</b>		
<b>Repair Method</b>	<b>Classification</b>	<b>Materials</b>
Asphalt Concrete Overlays	On Liquid Membrane	Epoxy, Polyurethane
	On Prefomed Membrane	Reinforced Asphalt, Reinforced Tar Resin, Rubber and Rubberized Asphalt
	Modified Asphalt Concrete Overlays	Epoxy-Modified Asphalt
Polymer Overlays	Multiply-Layer Polymer Overlay	Acrylic/Methacrylate, Epoxy, Epoxy-Urethane, Polyester Styrene, Polyurethane
	Premixed Polymer Overlay	Acrylic/Methacrylate, Epoxy, Epoxy-Urethane, Polyester Styrene, Polyurethane & Sulfur
	Slurry Polymer Overlay	Acrylic/Methacrylate, Epoxy, Epoxy-Urethane, Polyester Styrene, Polyurethane
Sealers	Acrylic	Acrylic, Acrylic Copolymer, High-Molecular-Weight Methacrylate (HMWM), Methacrylate & Methyl, Methacrylate
	Asphalt Emulsion	
	Cementitious	Nonpolymeric, Polymeric
	Epoxy	
	Gum Resin	Linseed Oil, Mineral Gum & Other
	Rubber	Chlorinated Rubber, Epoxide Chloride Rubber, Triplex Elastomer
	Silicone Based	Silane, Silane-Silicone, Silane-Siloxane, Silicate, Silicone, Siloxane, Sodium-Silicate
Urethane	Aliphatic & Isocyanate Polyether	

## Conventional overlays

Conventional overlays are placed on decks to reduce the infiltration of chloride ions and water and to increase the skid resistance. Because they are thin and tend to follow the contours of the deck, they cannot be used to substantially improve ride quality or drainage or to substantially increase the section modulus of the deck. However, because they are thin compared to bituminous and hydraulic cement concrete overlays, the increase in dead load is less.

Repair Method	Classification	Materials
Asphalt Concrete Overlays	On Liquid Membrane	Epoxy, Polyurethane Tar Emulsion, Thermoplastic
	On Preformed Membrane	Reinforced Asphalt Reinforced Tar Resin Rubber and Rubberized Asphalt
	On Tack Coat Modified Asphalt Concrete Overlays	Epoxy-Modified Asphalt Primers and Sealers Surface Treatment Chip Seal
Crack Repair and Sealing	Gravity Fill	Epoxy, HMWM, & Urethane
	Pressure Injection	Epoxy, HMWM, & Urethane
	Rout and Seal	Epoxy, Methyl Methacrylate
	Vacuum Injection	Epoxy, HMWM
High-Early- Strength Hydraulic- Cement Concrete Overlays	Alumina Cement	Rapid & Very Rapid-Hardening Cementitious Material (American Society for Testing and Materials (ASTM) C 928)
	Blended Cement Concrete Containing TYPE I, II, III Portland Cement & Admixtures	Corrosion Inhibiting, Epoxy, High-Range Water Reducing, Silica Fume, Styrene Butadiene Latex, Other Latexes
	Low-Slump Portland Cement Concrete	Rapid & Very Rapid-Hardening Cementitious Material (ASTM C 928)
	Magnesium Phosphate Cement	Rapid & Very Rapid-Hardening Cementitious Material (ASTM C 928)
	Rapid-Hardening Portland Cementitious Material Other Hydraulic Cement Concrete	Rapid & Very Rapid-Hardening Cementitious Material (ASTM C 928)
Patching	With Asphalt Concrete	Cold-Mix Asphalt Patch Hot-Mix Asphalt Patch
	With High-Early-Strength Hydraulic-Cement Concrete	Acrylic/Methacrylate, Epoxy, Epoxy- Urethane, Polyester Styrene, Polyurethane & Sulfur
	With Polymer Concrete	
	Polymer Overlay	

## **Asphalt concrete overlays**

Asphalt concrete overlays are placed on decks to provide a smooth riding wearing surface. The overlays are usually placed with a paving machine and compacted with a roller to provide a minimum compacted thickness of 1.5 in. (38 mm). Prior to placing the asphalt overlay, all patching must be complete. For deck protection and rehabilitation, a membrane is usually placed on the portland-cement concrete deck to protect the concrete from chloride ion infiltration. Low-permeability concretes such as latex-modified concrete, low-slump dense concrete, or concrete containing silica fume do not require the placement of a membrane. A tack coat can be applied to these surfaces prior to placing the overlay. For deck repair and improvement of skid resistance, an ultra-thin asphalt overlay, usually referred to as a chip seal, or surface treatment can be applied.

## **Portland-cement concrete overlays**

Portland-cement concrete overlays usually have a minimum thickness of 1.25 in. (32 mm) for concretes modified with 15-percent latex by mass of cement and 2.0 in. (51 mm) for most other concretes. Some concretes, such as those containing 7- to 10-percent silica fume or special blended cements like Pyrament, have permeabilities similar to that of latex-modified concrete and perform adequately at a thickness of 1.25 in. (32 mm).

## **High-early-strength portland-cement concrete mortars**

High-early-strength portland-cement concrete mortars having a thickness of about 1 in. (25 mm) have been used as overlays, but tend to crack and do not provide much protection unless latex or silica fume is added to the mixture. Overlays can be constructed and cured to a strength suitable for traffic in less than 8 hr using special blended cements such as Pyrament; Type III portland cement and admixtures such as corrosion inhibitors, high-range water reducers, latex, and silica fume; and rapid-hardening cementitious materials. More conventional high-early-strength portland-cement overlays such as those prepared with Types I and II portland cement and silica fume or Type III cement and latex can be constructed and cured with a lane closure of less than 56 hr. The deck may be patched prior to the placement of the overlay or as the overlay is placed.

The most common method of permanent spall repair is patching with hydraulic-cement concrete. Patches may be shallow (above level of reinforcing bars but at least 1.3 in. (33 mm) thick), half depth (at least 1 in. (25 mm) below top mat of reinforcing bars but not deeper than one half the deck thickness), and full depth. A typical repair includes squaring up the area to be patched, sawcutting the perimeter to a depth of 1 in. (25 mm), removing concrete to the required depth with pneumatic hammers weighing < 30 lb

(< 14 kg) with a sharpened chisel point at least 3 in. (76 mm) wide, blasting the concrete surface and reinforcing bars with sand or slag, applying bonding grout if conditions so warrant, filling the cavity with the patching material, consolidating and striking off the material, and applying liquid or other curing material. When full-depth patches are constructed, it is necessary to suspend forms from the reinforcing bars or to support forms from beam flanges (areas > 3 ft<sup>2</sup> (0.28 m<sup>2</sup>)). Hydro-demolition may also be used to remove concrete prior to patching. As can be seen from Table A2, many types of patching materials can be used. Patches can be constructed and cured to a strength suitable for traffic in less than 8 hr using special blended cements such as Pyrament; Type III portland cement and admixtures such as corrosion inhibitors, high-range water reducers, latex, and silica fume; rapid-hardening cementitious materials that satisfy the requirements of ASTM C 928; magnesium phosphate cement; and alumina cement. The most frequently used material is the rapid-hardening cementitious material meeting the requirements of ASTM C 928. Many of these materials achieve a compressive strength of 2,500 to 3,000 psi (17 to 21 MPa) in 3 hr or less depending on the temperature (Sprinkel 1993).

High-quality patches can be obtained when good mixture proportions are specified (minimum cement and water contents) and when steps are taken to eliminate the cause of spalling. Some of the cements have a high alkali content, and early age deterioration due to alkali-silica reactions is a concern when patching concrete that contains alkali-silica reactivity susceptible aggregates. Also, many of the concretes exhibit high shrinkage compared to bridge-deck concrete when used at manufacturers' recommended proportions.

## **Classification of Concrete-Polymer Composite Materials**

Materials used for major transportation, commercial, and industrial construction projects worldwide have not changed over the years. The primary building materials have been concrete, asphalt, wood, brick, iron, and steel. These materials are plentiful, familiar to craftsmen, and usually adequate in performance. However, with the industrial and technological developments of today, construction materials are called upon to perform under more vigorous conditions than in the past. Chloride corrosion, freezing-and-thawing cycling, polluting chemicals, and heavy vehicular traffic often cause cracking, spalling, and general deterioration of concrete structures. These conditions have created the need for new products capable of better withstanding these conditions.

The main thrust in the development of new construction materials has been in the field of synthetic polymers, such as epoxies, polyester, and methyl, as well as polyacrylates, polysulfides, butadienestyrene elastomers and polyvinyl acetates (Calvo and Meyers 1991; Johnston 1987; Dinitz and Ferri 1985; Emmons et al. 1993, 1994; Fontana et al. 1991; Fowler 1985; Furr 1984; Heiman and Koerstz 1991; Hewlett 1993; Hime 1993, 1994; Jenkins, Beecroft,

Heiman and Koerstz 1991; Hewlett 1993; Hime 1993, 1994; Jenkins, Beecroft, and Quinn 1974; Kukacka et al. 1975). Several new materials are actually used in bridge construction and maintenance, i.e. new materials never previously used in the field or materials that have been borrowed from other engineering fields. The purpose is, of course, to take advantage of new or improved performance in comparison with those of conventional materials. Thus, new fiber-reinforced concretes have been used for bridge construction which were developed from the use of composite materials in mechanical and aeronautic engineering; polymers, plastics, and thermosetting resins are now used intensively both as admixtures for structural and accessory materials (such as mortars, concretes, and glues) in new buildings and repair and maintenance of existing buildings, and as main constituents for service components in buildings (such as glass fiber-reinforced polymer pipes for drinkable and waste water, electrical, thermal and acoustical insulations, sealing and waterproofing materials, protecting paints and varnishes, etc.). The wide spectrum of modern concrete-polymer composites (CPC), now in the market or being developed in several countries, is shown in Figure A1.

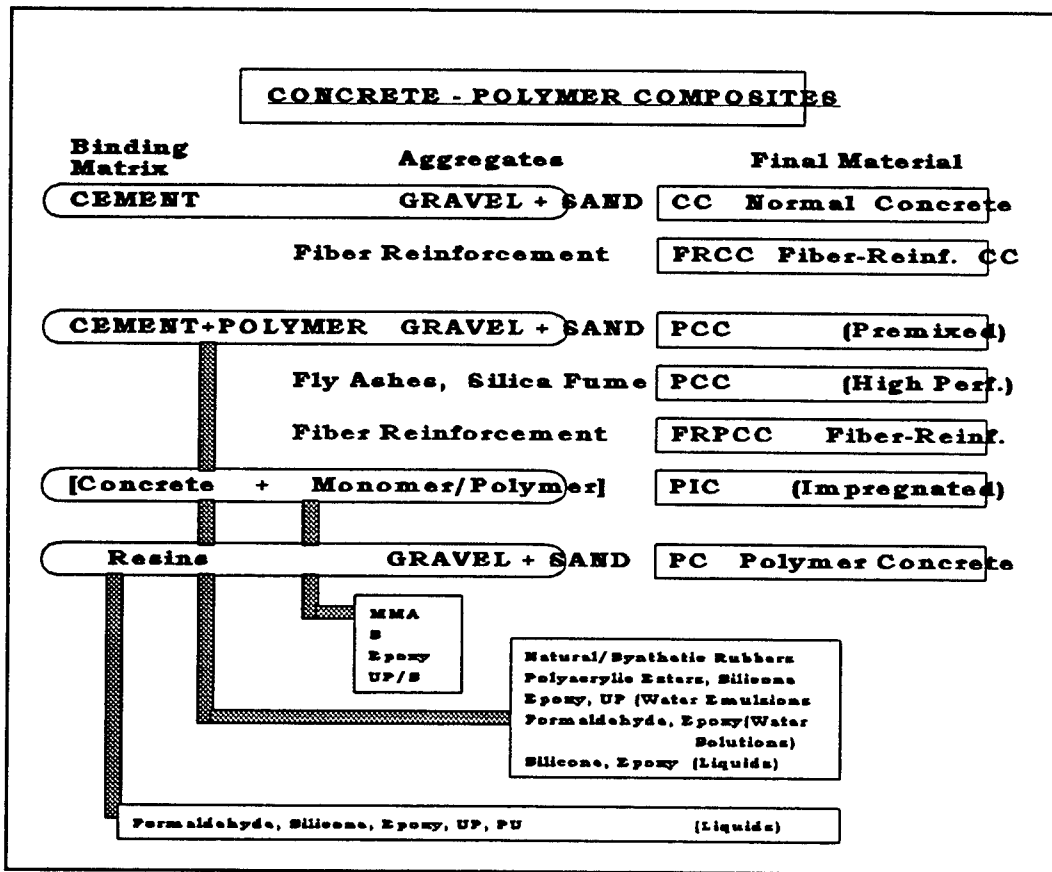

Figure A1. CPC materials

There are three basic types of CPC: polymer portland-cement concrete (PCC) (sometimes known as polymer-modified concrete) is a

premixed material in which either a monomer or polymer is added to a fresh concrete mixture in a liquid, powder, or dispersed phase, subsequently allowed to cure, and if needed, polymerized in place. Polymer-impregnated concrete (PIC) is a hydrated portland-cement concrete that has been impregnated with a monomer and is subsequently polymerized in situ. Polymer concrete (PC) is a composite material formed by polymerizing a monomer and aggregate mixture. The polymerized monomer acts as the binder for the aggregate. All these materials may be reinforced by steel, glass, and polymeric fibers, and adhesion between the matrix and fibers is improved by the admixture of a polymeric phase.

### **Polymer-impregnated concrete (PIC)**

PIC was initiated in the late 1960's under the Concrete-Polymer Material Program as a joint effort between Brookhaven National Lab and the Bureau of Reclamation. The basic principles of the technology itself, including the guidelines for selecting monomers, the application procedure, test results of the improvement in mechanical and other properties, and the status of the technology, have been topics of many review papers both within the United States and around the world. Results of many field tests on PIC have been reported since the 1970's. Conventionally, deep impregnation of 1 to 3 in. (25 to 76 mm) below the surface was demonstrated provided that the concrete was heated up to 210 °F (99 °C) at a depth of 4 in. (102 mm) below the surface for polymerization to occur. Surface impregnation to a depth of 0.5 to 1 in. (13 to 25 mm) on bridge decks has been found to be technically feasible (such as with the grooving method). The procedure for conventional impregnation technology involves: (a) cleaning the surface; (b) drying the concrete to remove moisture from the area where impregnation is planned (hydrophobic property of monomer, heat surface to 250 °F (121 °C), duration 6 to 8 hr); (c) impregnating the surface with a monomer system methyl methacrylate (MMA), initiator, promoter; (d) heating the impregnated areas at least 5 hr (at 158 to 194 °F (70 to 90 °C)); and (e) removing the remaining sand layer, debris (Kennedy 1997, Prowell et al. 1993, Smoak 1978, Weyers and Cady 1990). Obviously, elimination of heating for the drying and the polymerization steps is thought to be necessary to make this process more attractive. One possible method to eliminate heating may be to apply ultrasonic technology (UT) (Wu and Brooman 1993) during the impregnation step to facilitate the impregnation process without prior heating. The disadvantages of this UT are (a) a special apparatus is needed and (b) heating the specimen during the polymerization period is required.

### **Polymer cement concrete (PCC)**

PCC has been in use since the 1950's, when latex-modified concrete (LMC) was developed. Both styrene-butadiene (SBR) and acrylic have been used. SBR has been widely used in LMC for the purpose of constructing overlays (1-1/2

to 2 in. (38 to 51 mm) for bridge decks and parking garages. PCC has considerable attraction since the process technology is very similar to ordinary concrete. About 59,993 yd<sup>3</sup> are placed each year on both new and existing deteriorated structures. Mobile mixers using continuous mixing are generally used. The bond to the parent concrete is usually very good, the compressive and flexural strengths are improved, and the resistance to water and chloride intrusion is very good. Acrylic latex concrete has similar properties as SBR latex concrete. It is used to patch or resurface portland-cement concrete pavements and finished floor surfaces. It is also used as a spray-on coating for concrete surfaces because of its excellent color stability and durability. Epoxy-modified concrete (EMC) is also produced by adding special epoxies to the portland-cement concrete. The resin and curing agent are added separately. The EMC is placed and finished similar to normal concrete. It has improved strength and durability properties, and it has very good resistance to penetration of water and chloride. It is used for patching concrete and for thin overlays on parking garages, bridges, and other concrete surfaces. It is likely that more monomers and resins will become available in the future to produce PCC.

### **Polymer concrete (PC)**

PC became the dominant material in the 1980's. Although it was first produced in the 1950's for making synthetic marble, it was not until the mid-1970's that PC became widely known as a repair material for portland-cement concrete, particularly in the repair of highways and bridges. Many resins have been used to produce PC; a wide range of cure times, cure temperatures, strengths, stiffness, and other properties are possible. Initially, user-formulated PC systems were used almost entirely with both polyester styrene and methyl methacrylate used as the binder. A commercially available PC system using MMA was introduced in Europe in 1961 and has been used worldwide. Similar systems were developed and marketed by other manufacturers. These materials are provided in two components. One component is the liquid monomer, and the second component consists of well-graded fine aggregate, colorants, initiators, and thickeners. The two components produce a PC mortar that can be used for thin overlays or repairs. Coarse aggregate can be added to extend the PC for thicker repairs. One of the fastest growing uses of PC is for precast components. For years, the only precast PC products besides cultured marble counter tops and bathtubs were building panels. Other products were introduced beginning in the late 1970's and early 1980's including floor drains, utility trenches, utility vaults and covers, high-voltage insulators, floor tile, and hollow median barriers.

More and more applications will involve reinforced PC. For several years, partial and full-depth PC bridge-deck repairs have used the structural properties of PC. However, little research has been reported on the flexural or shear strength and behavior of reinforced PC. Recent studies have investigated the flexural behavior of reinforced PC beams made with five different

monomers and resins. The type of polymer was found to significantly affect the behavior of the beams.

## **Monomers and Resins**

Polymer materials that are commonly used in the repair of concrete structures include epoxy resins, the acrylic/SBR modifiers, methacrylate, HMWM, epoxy-urethane, polyester styrene, polyurethane, sulfur, vinyl, etc., and non-polymer materials such as special cements and additives.

Chemical companies have begun to develop monomers and resins especially for the concrete-polymer materials industry as the potential market has become obvious. It is likely that many new and innovative materials will be on the market before the turn of the century. The future for this industry looks bright. Many types of monomers and resins are used to produce polymer concrete. The most common types of monomers and resins are MMA, polyester-styrene, and epoxy. Others not as widely used are furan, urethane, and vinyl ester. MMA and polyester are the lowest cost monomers used to make PC. MMA has been widely used, but the higher flammability and disagreeable odor have limited its use. Polyester styrene is being widely used for manufactured products, while MMA is still used for many of the commercially prepackaged systems. In the area of overlays for bridges, polyester styrene and epoxy seem to find the widest usage.

## **Highway Uses of Concrete-Polymer Materials**

From the construction application standpoint, old structures are deteriorating at an alarming rate, while new ones need to be constructed with stronger materials to reduce the cost of repairing. Therefore, the new materials needed should have the following characteristics: (a) the bond and cohesive strengths should be significantly greater than the cohesive strengths of concrete; (b) the rate of strength development should be considerably faster than the strength development of concrete allowing significant savings in time; (c) curing shrinkage should be extremely small; and (d) the material should be most compatible with conventional portland-cement concrete.

During the past few years, under the auspices of the Federal Highway Administration (FHWA), many state Departments of Transportation, various governmental and private engineering agencies, and commercial producers have developed many new exciting and cost-effective uses and applications for concrete-polymer composites. The creative and innovative nature of the construction industry continues to expand on the use of polymer materials as well as to develop new construction techniques and mechanization processes for its most effective use and application.

## Epoxy

Epoxy resin was brought to the attention of the highway industry in its intense activity of construction, maintenance, and repair during the years immediately following World War II. The material, discovered only a few years before the war began, had properties that were very attractive to the industry. It was an excellent adhesive, it had good strength and durability, and it appeared to be workable and adaptable to the needs of highways.

The first application of epoxy to highways in the United States was by the State of California in 1954 when it was used to bond traffic buttons to pavements (Furr 1984). Since then, its use has expanded to include use as: (a) manufacturing material for traffic markers; (b) binder for traffic markers, broken pieces of concrete, and new plastic concrete to old concrete; (c) waterproof surface sealer, membrane, and thin epoxy-mortar overlay; (e) skid-resistant surfacing for slick pavement; (f) binder for aggregate to produce epoxy concrete and mortar for concrete patches and overlays; (g) crack filling and jointing material to prevent leaks; (h) structural bond for crack repair, including delaminated concrete pavements and bridge decks; (i) bolt, pipe, dowel, and reinforcing-bar anchorage in formed and drilled holes; (j) additive to portland-cement concrete to reduce water absorption; (k) coating for reinforcing steel to prevent corrosion; (l) adhesive for bonding shear connectors for composite beam action; (m) joint material for precast concrete elements; and (n) adhesive for bonding flat steel to concrete.

Of the many resins that are commercially available, the one made by epichlorohydrin with bisphenol A in the presence of caustic soda makes up some 95 percent of all used today. This resin, diglycidyl ether of bisphenol A (DGEBA), is used with concrete in highway applications. To be effective, the resin must be cured or hardened. This is accomplished by mixing it with an appropriate curing agent. A reactive curing agent acts as a link that joins the epoxy groups; a nonreactive agent, a catalyst, causes the groups to react with one another. The chemical reaction binds the groups together in three dimensions to produce a solid system. Once the reaction has begun, it can be slowed down or sped up, but cannot be undone. The system has essentially no strength until the reaction is complete.

In addition to the great number of systems that can be produced with different combinations of resins and curing agents, there are a number of modifiers (such as diluents, flexibilizers and plasticizers, inert fillers, and fire-retarding additives) that may be used to change certain properties of the system to best fit the needs of the job. Some modifiers are reactive, and others are inert. There are modifiers that affect viscosity (during mixing and placing), curing rate, flexibility, plasticity, thermal expansion, strength, appearance, and cost.

## **Effects of temperature**

At low temperatures, epoxy is a hard, brittle, glass-like material. It becomes softer, flexible, and rubber-like at sufficiently high temperatures. In general, low temperature reduces the workability of the resin because it increases viscosity; it also increases pot life and curing time. Warm temperatures enhance workability and reduce pot life and curing time. Cold resin and hardeners will work more easily and cure faster if they are heated to the 60- to 90-°F (16- to 32-°C) temperature range. If fillers such as sand are used, they can be heated or cooled, as desired, for better mixing and curing. When applied to a cold concrete, the curing time of the epoxy system will be increased. Because of this, most epoxy work on highway concrete is done when the concrete temperature and air temperature are in the range of 60 to 90 °F (16 to 32 °C) and air temperatures are rising. If the concrete is heated to receive epoxy, care should be taken to heat uniformly and to maintain the heat throughout the curing period.

## **Effects of water and chemicals**

No water is produced in the curing of epoxy, and the cured system is a tight, cross-linked system that permits essentially no water to be absorbed into it. Because of this property, it is widely used as waterproofing for concrete and other construction materials. Some epoxy formulations will not bond to wet concrete. There are, however, systems available today that will displace the water and provide good bonding to wet surfaces. The water-insensitive systems have somewhat less strength than those that are water sensitive. This reduced strength is not a problem, however, because epoxy is generally considerably stronger than the concrete to which it is applied. The nonsensitive systems will bond to clean wet concrete, and they are used for filling wet cracks, for underwater patches, and for other applications to wet concrete surfaces.

## **Stresses caused by volume changes**

The part of shrinkage that occurs after gellation has been formed is termed "effective shrinkage" and is addressed by ASTM C 883. The magnitude of shrinkage is influenced by the curing agent, the modifiers, and the curing temperature. In general, a fast-curing agent increases shrinkage, as does a high-curing temperature. An inert sand filler and a low-curing temperature will each reduce it.

There is always restraint to volume change in epoxy when it is used with concrete, and stresses result from this restraint. Curing shrinkage in the solid phase and differences in the coefficients of expansion of concrete and epoxy both contribute to these stresses. A thin membrane of epoxy bonded to concrete is restrained in the plane of bonding in two directions. The membrane is free to expand or contract linearly in the third dimension. A pothole filled with an

epoxy patching material is restrained in the plane of the pavement, but there is also some restraint in the third dimension because of bonding to concrete around the sides. During curing, the patch itself loses heat to the cool concrete with which it is in contact faster than to the air contacting the top face.

Portions of epoxy used as a crack filler are restrained in three dimensions. If a patch is too bulky, the curing heat loss at its center is slower than at its outer regions, and the dimensional changes in these two regions develop stresses within the patch. Most epoxies have the ability to absorb the 0.7-percent elongation as well as the 2,955-psi (20-MPa) tension and the 522-psi (3.6-MPa) shear (Furr 1984). Repeated applications of such strains and stresses, however, place far greater responsibilities on the epoxy with attendant greater chances of failure.

### **Tests and specifications**

Specifications and guides for epoxy materials and applications with concrete have been published by ASTM, the American Association for State Highway and Transportation Officials (AASHTO), and the American Concrete Institute (ACI). ASTM gives the requirements of the epoxy materials for various uses and describes tests to ensure that those requirements are met. AASHTO specifies epoxies to meet the various service requirements of highways and classifies epoxies for various conditions. ACI gives information on ways that epoxy can be used with concrete including repair, preparation, and application of the epoxy. In general, ASTM and AASHTO are concerned more with the epoxy material while ACI is concerned with its application. Among the three organizations, the subject is fairly well covered except for formulation and specific mechanical properties of various formulations.

### **Methacrylates**

Methyl methacrylate (MMA) uses a high-quality reactive resin as the sole binder. This reactive resin is a mixture of various monomers. With the addition of an initiator, usually an organic peroxide, these monomers will join together in a chain. As the chemicals polymerize, the filler, in the form of fine-filler-graded sands and aggregates, is incorporated into the mixture. MMA is a self-curing material. After the material is placed, a film forms over the surface and eliminates evaporation. Although the liquid component is flammable, the patch itself is not because the surface film acts as a barrier to flame. MMA is an optimum repair material because the stress exhibited by this material is similar to portland-cement concrete. This was accomplished by reducing the modulus of elasticity. The coefficient of thermal expansion is also about the same as portland-cement concrete. Polymer concrete (with MMA) is not only rapid setting and high strength, it is also the material most compatible with conventional portland-cement concrete. MMA is insensitive to traffic vibrations because of its rapid transition from a liquid to a gel state, and MMA bond tests

have always resulted in substrate failures. MMA has been used successfully for more than 20 years in Europe and the United States. Initially, MMA was used in the United States for patching roadways and bridge decks and for thin 1/4- to 1/2-in. (6- to 13-mm) overlays.

MMA behaves similarly to portland-cement concrete since both materials have compatible thermal stresses that eliminate delamination caused by heating-and-cooling cycles. When combined with an MMA primer system, these repairs are completely waterproof, protecting underlying steel from corrosion resulting from salt penetration.

Since MMA is a rapid-setting, permanent material that can be placed using conventional tools in temperatures ranging from 14 to 100 °F (Dinitz and Ferri 1985), it is ideally suited for many applications including joints, spalls, and modular bridge construction. The use of MMA is very cost effective if all factors are taken into consideration. Overlays on existing concrete roadways as well as bridge-deck rehabilitation using MMA result in a wear- and skid-resistant road surface (Scarpinato 1985). The advantages of using MMA to make polymer concrete are as follows:

- a. *Rapid set.* Polymer concrete hardens to over 5,000 psi (34 MPa) in compressive strength in 45 min to 2 hr depending on the temperature. This minimizes down time.
- b. *Permanent.* Polymer concrete bonds strongly to concrete eliminating repeated maintenance.
- c. *Ease of use.* Polymer concrete mixes easily and quickly; it is placed simply with a trowel or screed, does not stick to tools, has a controllable consistency, and feathers to zero.
- d. *Wear and skid resistance.* Polymer concrete is formulated using aggregates with different abrasion characteristics to maintain optimum skid resistance and to eliminate surface polishing as the overlay becomes worn. Wear resistant qualities are almost three times that of normal concrete.
- e. *Year-round use.* Polymer-concrete application temperature range is from 15 to 100 °F. This allows permanent patching during the winter months.
- f. *Water and salt resistance.* Polymer concrete is impervious to water, salt, and other deicing chemicals.

HMWM (Marks 1990, Rodler et al. 1989) refers to dicyclopentenyl methacrylate and its close relatives. This family of methacrylate monomers has a viscosity in the range of 8 to 40 cps. Tests have shown HMWM monomers to be well suited for repair of narrow cracks in portland-cement concrete.

The skid number deemed acceptable is 30. The use of HMWM on concrete pavement can lead to a potentially hazardous reduction in skid resistance. To alleviate the concerns raised by the poor skid performance of the test section, the following should be addressed: (a) every effort should be made to eliminate excess monomer from the surface of the treated pavement and squeegees should be used on smooth surfaces; (b) surface films of monomer with excessive thickness will take a longer time to polymerize due to oxygen inhibition of the polymerization; (c) the sand for broadcast on the treated surface should be applied at levels greater than 0.8 lb/yd<sup>2</sup> (0.67 m<sup>2</sup>); and (d) a coarser gradation of sand (1/8 to 1/4 in. (3 to 6 mm) will yield the best postapplication skid resistance.

## Applications

Repairs to concrete structures are carried out by casting or trowling on a repair material to a cutback base concrete which is deemed sound. In addition, injecting/impregnation or spraying may be used as a construction method. Most agencies report success with the use of concrete-polymer composites for patching spalls and potholes. Crack repair is another area where epoxy and HMWM have been used with good results, particularly where injected into inactive structural cracks. More recently, most agencies have begun to use epoxy-coated reinforcing steel in bridge decks. Although this use is still being evaluated in some states, others report that it is performing well. Epoxies have also been used successfully to set anchor bolts and as bedding for bearing plates.

### Site preparation

Successful placement begins with proper surface preparation because the patch bond is no stronger than the concrete to which it is being bonded. Improper surface preparation will result in a weaker bonding. The first step is to remove all unsound concrete and temporary patching using a jack hammer or chipping hammer. The next step is to remove all grease, asphaltic materials, oils, dirt, rubber, curing compounds, paint, carbonation, laitance, weak surface mortar, and other materials that may interfere with the bonding or curing of the overlay by scarifying mechanically, treating chemically, or sandblasting. If exposed steel is corroded, it should be sandblasted clean to remove surface scaling. It is not necessary to get to white steel. Finally, all loose particles should be removed by cleaning the area with a jet stream of air. The deck should be dry immediately prior to placement. Finally, patches of the overlay are usually placed and tested in accordance with ACI 503R (1992) or VTM 92 to ensure that the surface preparation procedure is adequate and the materials will cure properly to provide a high bond strength.

## **Crack repairing**

Cracks develop in concrete structures as a result of normal shrinkage, bad design, unforeseen stresses, bad workmanship, external damage, freezing-and-thawing cycles, earthquakes, and other factors. Cracks can be found in concrete that is used for highways. Some cracks cause no concern, but others do because they leak or they interfere with structural performance. Epoxy can be used both as a sealant for leaking cracks and as an adhesive to bond the cracked pieces back together again.

The most popular use of epoxy in crack repair is in structural crack injection. Almost all the users report that their repairs performed well. A much smaller number use epoxy mortar in crack repair, but all who have used it continue to do so. No users indicated that epoxy mortar performed poorly in their installations.

High-modulus, load-transfer grouts (with high strength and low elongation) are generally used for rehabilitation of concrete. Low-modulus, stress-relieving grouts (with lower strength and high elongation) are used when sealing cracks in areas where some degree of movement must be allowed. In any case, the grouts completely seal the cracks from intrusion of water, salts, or other chemicals when freezing and thawing or chemical attack can further undermine the concrete structure.

The most common technique of crack repair involves the installation of entry ports and sealing the surface of the cracks with an epoxy adhesive of gel consistency. The epoxy crack sealer is then injected under pressure, starting from the lower entry port and advancing upwards until the crack is completely filled.

## **Surface sealing**

The application of epoxy to the external surface of concrete for the purpose of waterproofing or dampproofing has been done for a long time with various degrees of success. Some of the earliest uses of epoxy served the double function of waterproofing and resurfacing rough concrete surfaces.

Epoxy used as a surface seal must have the ability to withstand temperature cycles encountered without debonding or cracking. When it is used on pavement surfaces or bridge decks, it has the additional requirement of withstanding traffic wear. No epoxy has yet been formulated that serves without fault under these conditions, although some have stood up for a year or more. Today, epoxy as a waterproofing material is used predominantly on surfaces not subjected to wheel wear. Substructure surfaces, such as pier caps below pavement joints, are frequently coated with epoxy to protect them against runoff water from the deck.

## **Penetrant**

A penetrant system must have a very low viscosity to enable it to penetrate into the concrete through the pores and minute surface shrinkage cracks. To do this, the epoxy system is cut back with solvents to approximately 20 to 30 centipoises at 77 °F (25 °C).

The solvent volatilizes soon after the system is applied, and a thin film of epoxy is left as a coating on crack and pore surfaces. To function optimally, the installation should permit moisture vapor to pass through to prevent a pressure buildup that could blister the sealer and eventually break it away. It is best applied to dry concrete when the temperature is constant or dropping as a precaution against blistering. Application is by roller, brush, or sprayer.

## **Membrane**

Epoxy used as a seal coat for concrete bridge decks and pavements was among the early applications of the material. Although the failures of such systems have not been as widely reported as their installations, several of these early treatments were not long-lived. It took only a matter of months to a year for these surface seals to unbond, crack, wear away, and further deteriorate.

In studying the types of failure, it was concluded that the primary cause of failure was the different coefficients of thermal expansion for epoxy and the concrete to which it was bonded. Epoxy has a coefficient of thermal expansion of four to eight times that of concrete, and, if unmodified, is brittle and easily cracks on an active road surface. The addition of flexibilizers, including coal tar, and fillers to give the epoxy greater capacity for elongation and to reduce the thermal expansion led to improved results.

## **Thin overlay**

The characteristics of MMA make it ideally suited for thin (1/2- to 1-in. (6- to 25-mm) bonded overlays. Due to its superior bonding capabilities, it is possible to place an overlay as shallow as 1/4 in. (6 mm). Since MMA exhibits stresses similar to portland-cement concrete, these overlays are very durable. Other advantages when using MMA for bridge-deck overlays are as follows: (a) since the material gels, overlays may be placed on active decks with no distress from vibration; (b) for small overlays or where there is little space, overlays may be hand-screeded; (c) since the material sets quickly and bonds to itself, applications may be made during off-peak hours; (d) MMA is a water- and salt-proof protective coating which protects the underlying steel from corrosion (because it extends the life of the deck, this type of overlay is eligible for Federal funding); (e) MMA is essentially a plastic and is slightly flexible (a rigid material would eventually delaminate under extreme flexing of

the deck); and (f) at 1/4-in. (6-mm) depth, there is no need to raise joints or barriers to compensate for the added height to the deck.

The initial use of epoxy for this purpose was aimed at providing a new surface and a water seal at the same time. Seasonal freezing-and-thawing cycles causing surface scaling of non-air-entrained concrete road slabs and bridge decks left many miles of concrete rough and sometimes polished. Furthermore, the corrosion resulting from deicing salt penetration to reinforcing steel caused extensive spalling in many areas.

### **Thick overlays**

Overlaying bridge decks with epoxy-based systems, which act as an impermeable traffic-bearing surface, has been attempted with various degrees of success for the last 25 years. Lack of knowledge in formulating techniques and understanding of the basic properties necessary for a successful installation, as well as methods of application, has resulted in many failures in the past. However, with today's state-of-the-art technology, epoxy bridge overlays have successfully functioned for the last 6 to 8 years under diverse climatic conditions and promise to be a successful tool in the preservation and protection of new or existing bridge decks. In addition to concrete bridge decks, orthotropic steel decks and concrete-filled steel grid decks have also been overlaid successfully with epoxy polymer concretes. MMA may also be placed as a thick overlay (1-1/2 to 2 in. (32 to 51 mm)). These applications are actually repairs to areas where latex-modified or dense concrete overlays have delaminated since MMA is compatible with either of these materials.

The following properties of the epoxy binder are considered important for any overlay installation: (a) tensile strength 200 psi (1.4 MPa); (b) tensile elongation 30 percent; (c) bond strength 1,500 psi (10 MPa); and (d) cure time 4 hr at 77 °F (25 °C).

The coefficient of thermal expansion of epoxy concrete systems is at least three times higher than that of portland-cement concrete. This difference can create interface stresses during cycles of freezing and thawing or mechanical movements that cause failures. The use of very flexible, low-modulus systems is necessary to provide stress relief and avoid fractures at the bond interface or more frequent cohesive failures of the portland-cement layers adjacent to the bond line.

### **Spall repairs**

By using a small gravel (typically 1/8 to 3/8 in. (2 to 10 mm)), a spall of 1 in. (25.4 mm) or less can be repaired at very nominal cost and should be done before the deterioration has a chance to spread. Quick, permanent repairs of spalls on bridge decks is a highly cost-effective maintenance procedure.

If bridge-deck damage escapes early detection or is not promptly repaired, deterioration becomes more extensive and may cause corrosion of the reinforcing steel. For deep spalls, concrete removal should include undercutting the reinforcing bar and commercial sandblasting the steel. It may sometimes be necessary to remove and replace badly damaged reinforcing bars.

MMA material may be filled with larger aggregate (typically 1-1/4 by 1/8 in. (31 by 3 mm)) and stucked, shoveled, or vibrated briefly with a finger vibrator to ensure migration of the fines under the reinforcement bars. It is unlikely that there will be any segregation of the MMA from the vibration. The waterproof MMA will act as a barrier to moisture and will protect the steel from further corrosion caused by deicing chemicals or salt water.

### **Skid-resistant surfacing**

Concrete surfaces that have become polished by traffic can be made resistant to skidding by bonding an abrasive grit to the wearing surface with epoxy. To do this, the concrete surface is thoroughly cleaned; the epoxy is applied and spread thin with a squeegee, and the surface, when it becomes tacky, is broadcast with sand or grit to provide the skid-resistant surface. It can also serve to smooth the surface. Epoxy broadcast with natural sand as a skid-resistant wearing surface has been found to wear badly and become slick in the tire paths. More recently, aluminum oxide grits broadcast on epoxy are giving good service. These grits do not wear or polish as much as sand, and they stay in place better. They are, however, more expensive than natural sand. The epoxy must be flexible because if it is brittle, it will debond in cold weather.

Many agencies have used epoxy to prepare skid-resistant surfaces for concrete roadways, but most have discontinued its use for such reasons as wear, debonding, polishing, lost aggregate, and high costs. The surfaces using aluminum oxide grits are much more serviceable than those using natural sand. Only surfaces using wear-resistant grits, such as aluminum oxide, and flexible epoxies can maintain their bond in cold temperatures and have any appreciable chance of survival.

### **Reinforcing-bar coating**

Spalling damage, which has been so destructive to reinforced-concrete bridge decks, was traced years ago to the corrosion of reinforcing steel brought on by salt used to melt winter ice. Subsequent research found that a coat of epoxy on reinforcing steel would isolate it from chloride-laden concrete and protect it from corrosion. It has been the practice for a number of years to coat exposed reinforcing steel in bridge-deck patching operations with liquid epoxy, but this could not prevent the corrosion that caused the spall in the first place, nor stop corrosion adjacent to the patch.

Injection techniques can be used to fill narrow cracks down to about 0.005 in. (1.27 mm) wide and sometimes narrower. This technique forces the epoxy under pressure to fill the crack, coat the surfaces, and bond the surfaces together when cured. The injection of epoxy resin as a method of repairing cracks or filling voids in structures has been used since 1950's (ACI 1962, Tremper 1960). The technique was first applied to the repair of delaminations in bridge decks by the Kansas State Highway Commission in 1964. Since that time, the equipment and procedures have been significantly improved (Prowell et al. 1993, Smithson and Whiting 1992), and this has developed into one of the most successful methods of concrete repair with epoxy.

## **Selection of Concrete-Polymer Materials**

### **Considerations**

When a repair project is considered, the structural engineer must first decide the application of the repair material and then the properties required to fulfill the application. Commonly measured compressive strength is a poor guide to performance. Key properties are those with time and the effects of different environments.

The engineer, faced with such a wide choice of materials and little guidance on the required or actual performance, may opt for ones having properties as close to those of the base concrete as possible. Unfortunately, this conclusion is illogical (Emmons et al. 1993, 1994; Hewlett 1993; Hime 1993, 1994; Holland 1992; O'Connor and Saiidi 1993; Plum 1990; Surlaker 1992; Tourney and Berke 1993), and in the process of achieving parity, the engineer may discard the very useful properties which are present in most of the polymers. The temptation to seek parity of properties of the repair material and base concrete is strong, but attempts to avoid mismatch flounders in the definition of compatibility.

The inspection of screeds, toppings, and patch repairs that have failed indicates that perfect parity of material properties will not necessarily prevent failure. The real requirement is that the repair material will have properties and dimensions compatible with the substrate for the application in hand. It is clear that a greater knowledge of the meaning of physical and chemical compatibility is needed.

The polymer materials may be formulated to provide a very wide range of properties, from brittle to ductile, impermeable to porous, and skid resistant to water shedding. Several material properties must be considered when evaluating alternative repair systems: (a) ability to bond adequately to the substrate; (b) movement relative to the substrate, which depends on shrinkage, thermal movement, and behavior on wetting and drying; (c) permeability to water, gases, and aggressive ions; (d) chemical passivation of reinforcement; (e) strength; (f) ease of application; and (g) durability under cycles of freezing

and thawing, chemical attack, and weathering. Therefore, the principal functions generally sought by formulators may include:

- a.* Low permeability.
- b.* Temperature and humidity effects.
- c.* Chemical resistance.
- d.* Elastic modulus.
- e.* Surface penetration.
- f.* High strength.
- g.* Creep and shrinkage.
- h.* Free flowing.
- i.* Bond strength.
- j.* Shelf life, pot life, etc.
- k.* Low viscosity.
- l.* Water shedding.

Polymer materials are influenced by environmental conditions during the curing phase and in service.

Of all the material properties, some of the long-term hardened state ones are the least understood, and the material may be poorly researched for use in structural applications.

As a result of wide-ranging deterioration, a repair material may be required to fulfill one or many of the following applications: (a) stress carrying where a significant amount of compression material has been lost; (b) production of a low-permeability casing where water chemicals or carbonation is likely to cause reinforcement corrosion; (c) provision of increased wear resistance where abrasive conditions exist; and (d) restoration of appearance where cracking or spalling has occurred. As a result, the applications may be broadly classified as structural (stress-carrying) and cosmetic (all others).

As far as different applications are concerned, the different properties of the repair materials should be emphasized. The environmental conditions to which the repair materials are subjected may vary widely both during curing and in service. The effect of such varying conditions on the performance of the repair needs to be studied with respect to behavior in both structural and cosmetic

applications. Clearly, some theoretical assessment is required to give guidance as to the relative importance of specific properties for each application.

### **Significance of mechanical properties**

Study of the significance of the mechanical properties of repair materials has shown the importance of some of these properties, such as the properties of elastic modulus ( $E_r$ ), creep coefficient, and interface bond strength. In addition, compressive strength is significant in structural applications, and shrinkage and tensile strength are significant in screed applications.

Standard tests are defined by ASTM and British Standards, but do not cover all the properties listed previously. In particular, the properties of creep and interface bond are not covered by these standards, and in addition, the effects of temperature and humidity are left open.

### **Polymer concrete and its environment**

ASTM C 580 suggests 23 °C at a maximum of 80-percent relative humidity (rh), but in neither case are the standard effects of specific property variations of temperature and humidity considered. Ambient curing conditions were adopted for the tests to approximately satisfy the standard. In addition, the effects of varying the conditions from 10 °C to 35 °C and 30-percent rh to 95-percent rh were studied.

- a. *Compressive strength.* The moister environments led to reduced compressive strengths. There was little evidence that subsequent ambient or higher temperature curing would restore the strength loss.
- b. *Flexural strength.* The moister environments again led to reduced strengths, and in this case, there is evidence of strength loss during the period of moist cure. There is no conclusive evidence of recovery of strength during subsequent ambient or higher temperature curing.
- c. *Elastic modulus.* Despite the provisions of the test method, stability of strain readings is difficult to achieve, and environmental effects may well be masked by unstable readings. However, the test results indicate some similarities with the effects on strength, i.e. some reduction with increasing humidity.
- d. *Compressive creep.* As no formal creep tests are specified, a creep test method was adapted from that used traditionally for concrete.
- e. *Flexural creep.* As polymer materials are stronger in tension than normal concretes, a flexural creep test is possible in addition to the compressive creep test.

*f. Interface bond strength.* The bond test offered by BS 6319 is in fact a slant shear test in which interfaces are subjected to a combination of compression and shear. In general, failure occurred within the concrete substrate. The results were totally dependent on substrate preparation, with many forms of contamination giving a very low interface bond strength. Environmental effects appear to be negligible for this property.

By examining the significance of the mechanical properties, it is possible to identify the repair functions for each application.

The problem of creep performance of the repair materials is a complex one and is most significant. Many aspects of the subject need examination such as age at loading, duration of load, the relationship between compressive, tensile, and flexural values, and the wide range of environments.

The problem of the sensitivity of the material to good surface preparation also needs further research.

Further information is needed on the subject of rapid expansion (or contraction) in which creep does not play a significant part, e.g. thermal shock.

Consideration should be given to the modulus of the polymer and the strains the repair will be subjected to when a system is chosen for a given repair.

# Appendix B

## Polymer-Injection/Ultrasonic Pulse-Echo System for Concrete Bridge Repair

---

### Questionnaire

1. What are the main causes of the deterioration of the bridge decks in your area?
2. What is the average anticipated life of a concrete bridge deck in your area?
3. Is there any way by which you can detect if multi-delaminations exist in the bridge decks?
4. Which of the following methods do you employ to treat the deterioration of the deck? Please explain and add additional page if required.
  - (a) 3 in. (76 mm) or more of cover over the top reinforcing steel
  - (b) low-slump dense concrete overlays
  - (c) latex-modified concrete overlays
  - (d) interlayer membrane/asphaltic concrete systems
  - (e) polymer-concrete overlays
  - (f) polymer impregnation
  - (g) polymer injection and flood coating
  - (h) partial or full bridge-deck replacement
  - (i) others, please specify: \_\_\_\_\_
5. Which of the following methods do you choose to clean the surface of the bridge deck? Please explain and add additional page if needed.
  - (a) shotblasting
  - (b) sand/gritblasting
  - (c) hydroblasting
  - (d) airblasting
  - (e) scabbling impact tools

- (f) scarifiers
  - (g) others, please specify: \_\_\_\_\_
6. When you apply the overlays to the deck, do you measure the moisture content in the concrete? If so, what methods do you use?
- (a) ASTM D 4263
  - (b) Drilling small holes into the concrete
  - (e) others, please specify: \_\_\_\_\_
7. Is there any selective ambient temperature range for deck overlay? If so, what is this temperature range?
8. When choosing a particular repairing material, which of the following tests do you run? Please explain on an additional page if needed.
- (a) compressive, and tensile strength test
  - (b) moisture absorption test
  - (c) freeze-thaw test
  - (d) slab and beam test to study static and fatigue for excess load conditions
  - (e) petrographic analysis
  - (f) image analysis
  - (g) the influence of the internal moisture on the overlay
  - (h) others, please specify: \_\_\_\_\_
9. Have you experienced any polymer impregnation rehabilitation process in your area? What are some difficulties you are facing in polymer impregnation process? Please explain in brief detail about different projects. Add additional page if needed.
10. If you have used the polymer-injection method to repair the deterioration, please list the influencing factors from the list below and explain on an additional page if needed.
- (a) the choosing of a particular polymer material
  - (b) the location of the delaminations
  - (c) pattern of the injection holes
  - (d) size of the injection holes
  - (e) the method of surface cleaning
  - (f) the injection pressure
  - (g) the injection equipment
  - (h) others, please specify: \_\_\_\_\_
11. What percentage of cracks filled by polymer injection have you experienced?
12. What are the different kinds of polymers you have encountered in the bridge-deck rehabilitation process?

13. Out of total yearly expenditure in the field of bridge construction, what percentage is spent on the following:
- (a) construction of a new bridge
  - (b) repair of existing bridge
  - (c) extension of existing bridge
  - (d) money spent on future developmental activity in the line of bridge
  - (e) others, please specify: \_\_\_\_\_
14. What parameters do you consider for handling traffic volume during bridge repair work? Please provide hours of allowable closure, length of deck closed or restricted, etc.
15. What are the current practices related to rehabilitation and strengthening of concrete bridge deck in your area?
16. Please list some problems you have experienced in polymer injection and in impregnation of bridge decks during the process of impregnation and after impregnation, and briefly describe them on an additional page if needed.
17. Have you used an ultrasonic pulse-echo system to locate cracks in the deck and determine the effectiveness of the repair process?
18. Please provide a square foot cost for the following:
- (a) detection method
  - (b) cleaning procedures
  - (c) repair or injection process
  - (d) testing to determine effectiveness of repair
  - (e) traffic control
19. Do you know of any conceptual details, special provision, or reports which may be helpful in developing design guidelines for polymer injection for bridge-deck rehabilitation? If so, please provide the name of reference or provide copies.

# Appendix C

## Project Participants

---

### University of Nebraska-Lincoln

Robert Cook  
Engineering Building 131F  
University of Nebraska  
60th & Dodge Sts  
Omaha, NE 68182  
(402) 554-2564

Maher K. Tadros  
Engineering Building 125  
University of Nebraska  
60th & Dodge Sts  
Omaha, NE 68182  
(402) 554-2985

Mantu C. Baishya  
Engineering Building 131E  
University of Nebraska  
60th & Dodge Sts  
Omaha, NE 68182  
(402) 554-3274

Sherif Yehia  
Engineering Building 125  
University of Nebraska  
60th & Dodge Sts  
Omaha, NE 68182  
(402) 554-2820

Steve Cheny  
Engineering Building 131E  
University of Nebraska  
60th & Dodge Sts  
Omaha, NE 68182  
(402) 554-3565

Zhongguo (John) Ma  
Engineering Building 125  
University of Nebraska  
60th & Dodge Sts  
Omaha, NE 68182  
(402) 554-2820

### US Army Corps of Engineers, Omaha District

Mike Kelly  
CEMRO-ED-GE  
215 N. 17th St.  
Omaha, NE 68102  
(402) 221-4444

Dave Ray  
CEMRO-ED-GA  
215 N. 17th St.  
Omaha, NE 68102  
(402) 221-4493

Mark Buss  
CEMRD-ED-LS  
420 S. 18th Street  
Omaha, NE 68102  
(402) 444-4305

## **US Army Engineer Waterway Experiment Station**

Michel Alexander  
USACE-Waterway Experiment Station  
Attn: CEWES-SC-CE  
3909 Halls Ferry Road  
Vicksburg, MS 39180-6199 Phone: (601) 634-3237

## **Federal Highway Administration**

Milo Cress  
1000 Centennial Mall North  
Room 220  
Lincoln, NE 68508  
(402) 437-5521

Frank Doland  
Technology Transfer Engineer  
1000 Centennial Mall North,  
Lincoln, NE 68508  
(402) 437-5521

## **Kansas Department of Transportation**

Dave Meggars  
Materials and Research Center  
2300 Van Buren  
Topeka, KS 66611  
(913) 291-3845

## **Michigan Department of Transportation**

Ken Whelton  
Structural Maintenance Superintendent Maintenance Division  
7998 Creyts Rd.  
Dimondale, MI 48821  
(517) 322-3321

## **Mississippi Department of Transportation**

Alfred Crawley  
Research Division  
P.O. Box 1850  
Jackson, MS 39215-1850  
(601) 359-7650

Gayle Albritton  
Research Division  
P.O. Box 1850  
Jackson MS 39215-1850  
(601) 359-7650

## **Sika Corporation**

Casey Klepper  
4800 Blue Parkway  
Kansas City, MO 64130  
(816) 241-5153

## **Transpo Industries, Inc.**

Arthur Dinitz  
20 Jones St.  
New Rochelle, NY 10801-6024  
(914) 636-1000

Mike Stenko  
20 Jones Street  
New Rochelle, NY 10801-6024  
(914) 636-1000

## **Unitex**

Jerry Byrne  
3101 Gardner Ave.  
Kansas City, MO 64120  
(800) 821-5846

## **Liquid Control Corp.**

Nick DiDonata  
7576 Freedom Ave., NW  
P.O. Box 2747  
North Canton, OH 44720  
(330) 494-1313

## **E-Z Drill Inc.**

Randy Stevens  
Sales Manager  
2324 W. 7th Place #6  
Stillwater, OK 74074  
(405) 372-0121

## **U.S. Filter (Shoot Blasting)**

Travis McCutchen  
6215 Aluma valley Drive  
P.O. Box 36239  
Oklahoma City OK 73136-2239

## **Level 5 Information Builders, Inc.**

Ron Hencin  
503 5th Ave.  
Indialantic, FL 32903  
(800) 444-4303

# **Appendix D Guide Specification Category I**

---

## **Michigan Department of Transportation**

### **MAINTENANCE DIVISION LOCATION:**

B02-66032 US-45 over east branch of Ontonagan River, 2.0 miles south of M-26, Ontonagan County.

B03-66022 M-28 over south branch of Ontonagan River, 4.7 miles west of US-45, Ontonagan County.

B02-31021 M-28 over east branch of Ontonagan River, in Kenton, Houghton County.

R01-23063 I-69 NB over GTW & Billwood Hwy, 4.0 mi. NE of Potterville.

### **DESCRIPTION OF WORK:**

Provide all labor, materials, equipment, and traffic control for cleaning entire deck surface and applying a two-coat epoxy flood-coat overlay on four structures previously mentioned.

All the work in this contract is subject to the provisions of the Michigan Department of Transportation 1996 standard specifications for construction unless noted differently in this proposal. NOTE: SPECIAL PROVISIONS AND SUPPLEMENTAL PROVISIONS, WHEN APPLIED UNDER THIS CONTRACT, CONTAINING MEASUREMENT AND PAYMENT WILL NOT BE PAID SEPARATELY BUT ARE TO BE INCLUDED IN OTHER PAY ITEMS.

## COORDINATION CLAUSE:

There shall be weekly meetings between the contractor and Michigan Department of Transportation Contractor Administrator (CA) to discuss progress of the work and scheduling. The form and format of the meeting is to be determined in the preconstruction meeting to the satisfaction of Michigan Department of Transportation and the contractor. The contractor shall notify Michigan Department of Transportation Project CA a minimum of 14 days prior to starting work on any particular bridge. The contractor shall allow Michigan Department of Transportation crews to perform work, away from the bridge deck, utilizing the contractor's in-place traffic control devices if deemed necessary by the Project CA. Michigan Department of Transportation crews will coordinate with the contractor to minimize any impact on the contractor's work/progress schedule.

It is the contractor's responsibility to coordinate work with other contractors who might be working in the vicinity of the specified structures.

**SPECIAL NOTICE:** Due to the limited available funding for this contract, one or more bridges may be canceled. No adjustment in unit prices will be allowed due to the canceled work. Bridges could be deleted as required at any time to cover overruns.

### **Surface preparation:**

Before placement of the overlay, the contractor shall clean the entire deck surface by shotblasting to remove asphaltic material, oils, rubber curing compounds, paint carbonation, laitance, weak surface mortar, and other potentially detrimental materials which may interfere with the bonding or curing of the overlay. Acceptable cleaning is usually achieved by significantly changing the color of the concrete and mortar and beginning to expose coarse aggregate particles. Mortar, which is sound and soundly bonded to the course aggregate, must have open pores due to cleaning to be considered adequate for bond. Traffic paint lines shall be removed before shotblasting and replaced at the completion of the overlay. A vacuum cleaner shall be used to remove all dust and other loose material. Brooms shall not be used and will not be permitted.

Epoxy flood-coat overlay shall not be placed on concrete deck patches less than 28 days of age. Patching and cleaning operations shall be inspected and approved prior to placing each overlay. Any contamination of the deck or to intermediate course, after initial cleaning, shall be removed. Both courses shall be applied within 24 hr following the final cleaning and prior to opening area to traffic. There shall be no visible moisture present on the surface of the concrete at the time of application of the epoxy overlay.

During preparation of the surface, the expansion joint shall be protected from damage at all times. No epoxy shall be allowed to come in contact with the joint seals or glands.

**Application:**

Handling and mixing of the epoxy resin and hardening agent shall be performed in a safe manner to achieve the desired results, while avoiding air entrapment, in accordance with the manufacturer's recommendations or as directed by the Engineer/Contract Administrator. Epoxy flood-coat overlay materials shall not be placed when weather or surface conditions are such that the material cannot be properly handled, placed and cured within the specified requirements of traffic control.

Temperature: Surface or Ambient 10 °C (50 °F).

The epoxy overlay shall be applied in 2 separate courses in accordance with the following rate of application, and the total of the 2 applications shall be no less than 17 liters per 100 ft<sup>2</sup>.

<u>Course</u>	<u>Rate, liters/100 ft<sup>2</sup></u>	<u>Aggregate, kg/m<sup>2</sup>*</u>
1	No less than 5.7	5.4+
2	No less than 11.4	7.6+

\* Application of aggregate shall be sufficient quantity to completely cover the epoxy.

After the epoxy mixture has been prepared for the flood-coat overlay, it shall be immediately and uniformly applied to the surface of the bridge deck with a notched squeegee or stiff bristle barn broom. Epoxy shall not be applied if the ambient air temperature is to fall below 10 °C within 8 hr after application. The dry aggregate shall be applied in such a manner as to cover the epoxy mixture completely within 5 min. First course applications which do not receive enough sand shall be removed and replaced. A second course insufficiently sanded may be left in place, but will require additional applications before opening to traffic. Each course of epoxy flood-coat overlay shall be cured until vacuuming or brooming can be performed without tearing or damaging the surface. Traffic or equipment shall not be permitted on the overlay surface during the curing period. After the course one curing period, all loose aggregate shall be removed by vacuuming or brooming and the next overlay course applied to completion. The minimum curing periods shall be as follows:

Course	Average temperature of deck, epoxy, and aggregate components in °C					
	15-18	19-21	21-23	24-26	27-29	29+
1	4 hr	3 hr	2.5 hr	2 hr	1.5 hr	1.0 hr
2	6.5* hr	5 hr	4 hr	3 hr	3 hr	3 hr
* Course 2 shall be cured for 8 hr if the air temperature drops below 15 °C during the curing period.						

The Contractor shall plan and prosecute the work to provide the minimum curing periods as specified herein, or other longer minimum curing periods as prescribed by the manufacturer prior to opening to public or construction traffic, unless otherwise permitted. Course 1 applications shall not be opened to traffic.

In the event that the Contractor's operation damages or mars the epoxy flood-coat overlay, the Contractor shall remove the damaged areas and replace the various courses in accordance with this Specification at no additional cost to the Department.

For each batch provided, the Contractor shall maintain and provide to the Engineer and/or Contract Administrator records including, but not limited to, the following:

- a. Batch numbers and sizes (manufacturer's specification).
- b. Location of batches as placed on deck, referenced by stations.
- c. Batch time.
- d. Temperature of air, deck surface, epoxy components, including aggregates.
- e. Loose aggregate removal time.
- f. Time open to traffic.

During application of the epoxy overlay the expansion joints shall be protected at all times until the overlay job is complete. Deck drains shall be covered to prevent epoxy from entering the drains.

**Equipment:**

For the epoxy flood-coat overlay the distribution system or distributor shall accurately blend the epoxy resin and hardening agent, and shall uniformly and accurately apply the epoxy materials at the specified rate to the bridge deck in

such a manner as to cover 100 percent of the work area. The fine aggregate spreader shall be propelled in such a manner as to uniformly and accurately apply dry aggregate to cover 100 percent of the epoxy material. The vacuum truck shall be self-propelled.

For hand applications, equipment shall consist of calibrated containers, a paddle-type mixer, notched squeegees, and stiff bristle broom.

**MATERIALS:**

A. The epoxy system used in flood coating of the structure shall be a two-component, high-solids system. The epoxies that are approved by MDOT for flood coating, are as follows:

**APPROVED PRODUCTS LIST**

COMMODITY: Epoxy, Deck Flood Coat

Two-component high-solids epoxy, for use on bridge decks. Viscosity range of 7 to 25 cps, pot life of 15 to 45 min 24 °C, tensile strength of 13.8 to 34.5 MPa @ 7 days, tensile elongation 30 to 70 percent, color clear to amber, moisture insensitive, low surface tension. Quantities shown shall be parts A + B furnished in the proper proportions. Material to be clearly marked with product name and mixing instructions. Containers shall be marked clearly Part A or Part B. Product safety data sheets (three each) shall be sent with each shipment.

<u>BRAND</u>	<u>TYPE</u>	<u>VENDOR</u>
Unitex	Propoxy Type 3	Unitex, Inc. (Jerry Byrne) 3101 Gardner Kansas City, MO 64120 (816) 231-7700
Sika	Sikadur 22 LoMod	Sika Corp. (John Mahar) 22211 Telegraph Rd. Southfield, MI 48034 (313) 417-8978
Transpo	Transpo T48	Transpo Inc. (Mike Stenko) 20 Jones St. New Rochelle, NY 10801

B. The aggregate shall be angular grained silica sand or basalt having less than 0.2 percent moisture and free of dirt, clay, asphalt, and other foreign or organic materials. The aggregate shall have a minimum Mohrs' hardness of 7. Unless otherwise approved, the aggregates shall conform to the following gradation:

**APPROVED AGGREGATES LIST**

<u>VENDOR</u>	<u>PRODUCT</u>	<u>TYPE</u>
Flat Rock Bagging 27938 Cook St. Flat rock, MI 48134 Roger Brown: (313) 782-2073	Size # 3	Quartz
Dixie Cut Stone & Marble Sedimentary 6045 Dixie Highway Bridgeport, MI 48722 John Hoffmann: (517) 777-2575	Size: WEX-4-ED	
Manufacturers Minerals Co. 1215 Monster Rd. Renton, WA 98055 Jim Adderson: (206) 228-2120	Size: GB 10×30	River Rock
Humble Sand and Gravel, Inc. 800 S. College Rd. PO Box 217 Picher, OK 74350 (918) 673-1749	Size: # 7	Chipped Flint

**MEASUREMENT AND PAYMENT:**

Epoxy flood-coat overlay will be measured in square metres, which price shall be full compensation for deck preparation, for furnishing and applying the overlay courses.

Payment will be made under:

<u>Pay Item</u> _____	<u>Pay Unit</u> _____
Epoxy Flood-coat Overlay	Square metre
Mobilization	Lump Sum
Bridge to Bridge	Per Bridge
Traffic Control	Lump Sum

“Mobilization” (Maximum \$5,000) is described in Sect. 150. of the Standard Specifications except the payment is due in full upon completion of work on the first bridge. Bid any amount up to a maximum of \$5,000.

“Moving From Bridge to Bridge” (Maximum \$4,000) will include all costs associated with the Contractor’s cleaning up, restoring worksite, and moving from one bridge to another (whether or not the Contractor’s men/equipment, including traffic devices, move to the next bridge directly or move to their home base first). In certain cases, where some bridges are connected, they may

be paid only once for this pay item. Check "SUMMARY OF QUANTITIES" sheets. Bid any amount up to a maximum of \$4,000.

"Traffic Control Devices" paid for as a lump sum (LSUM) for each bridge; it will include all costs associated with providing and maintaining all traffic-control devices as required in the traffic-control layouts provided elsewhere in this proposal (all traffic-control devices shall be lighted) as well as replacing the paint lines. Traffic-control devices will be paid only once for each bridge.

The traffic-control devices shall be portable traffic signals supplied by the Contractor. The signals shall have a battery supplied backup of 14 hr. The Contractor shall assure that the signals are checked for proper operation at 12-hr intervals when being used at the worksite. The supplied signals shall have two signal heads mounted overhead and provide a minimum clearance of 15 ft. The system shall have hardwired and optional radio link communications with conflict monitoring and the Contractor shall have an authorized service center specified for timely response to all system failures. The base supporting unit must be located in the lane closure area on both ends of the structure. The supplied signals shall be ADDCO model #PTS-200 or MDOT APPROVED EQUAL.

# Appendix E

## Design Considerations

---

### Contrast Between Ultrasonic Pulse Echo (UPE) and Ultrasonic Pulse Velocity (UPV)

There are significant differences between through-transmission systems and pulse-echo systems. Through-transmission systems are narrow-band systems (high-Q), while pulse-echo systems are wide-band (low-Q) systems. Through-transmission systems employ a point source to introduce the acoustic energy into the material rather than a piston source. (A point source produces a spherical wave front, while a piston source produces a plane wave front.) A through-transmission system or point source has a small-area transducer with respect to the wavelength, while a pulse-echo system or piston source has a large-area transducer with respect to the wavelength. With through-transmission systems, the pulse length can be large with respect to the distance between the top surface and the reflecting interface, while for pulse-echo systems, the pulse length must be short with respect to the distance between the top surface and the reflecting interface. In summary, a through-transmission system has a different transducer construction than a pulse-echo system.

### Transducer Characteristics

An ideal UPE transducer has a broadband transfer function, which means it can generate or receive a short pulse with very little ringing. It is known that a low-quality-factor- (Q) pulsed system also has the benefit of reduced sidelobe energy and a less complicated near-field (Krautkramer and Krautkramer 1977<sup>1</sup>). Also, transducers with angled faceplates help direct the highest intensity P-wave energy from the transmitter transducer into the concrete and back to the surface to the receiver transducer for systems of pitch-catch configuration. A large transmitter area-to-wavelength ratio helps collimate the rays of ultrasonic energy and reduces the production of surface waves from mode conversion.

---

<sup>1</sup> References cited in this appendix are located at the end of the main text.

Collimation of the beam means that fewer rays of energy strike interfaces in the interior of the concrete that are not directly under the transducers and create fewer instances of undesirable echoes. A large receiver area-to-wavelength ratio also spatially averages backscattered energy from aggregate directly under the transducers and further reduces false echoes from random aggregate backscatter.

## Background on UPE

Materials such as metal, water, earth, and human bodies are routinely analyzed by reflected mechanical pulses using UPE technology. Piezoelectric crystals have been found to be a suitable source for creating and detecting these short pulses in concrete (Alexander and Thornton 1988). Typically, to detect flaws near the surface with these crystals, a pitch-catch configuration is used rather than one transducer when testing materials. This is also the case for concrete. This two-transducer configuration uses one transducer to pitch or transmit stress waves, and another transducer to catch or receive the backscattered stress waves.

## Wave Types

Another desirable property that a UPE transducer should have is that it generates primarily compression waves (P-waves). The most important types of waves produced are compression (primary), shear, and Rayleigh waves, which are denoted by symbols P-, S-, and R-waves, respectively. Particle motion is the determining factor that defines these wave modes. The motion of particles from a P-wave alternates back and forth in a straight line parallel to the direction of wave propagation (longitudinal), while S-waves are characterized by straight-line motion of the particles back and forth perpendicular to the direction of propagation (transverse). R-waves travel only on the surface, and the particles move in a plane in an elliptical type of motion with the plane being parallel with the direction of propagation. All three wave modes travel at different velocities.

The following relationship determines the velocity of the compressional or longitudinal wave, based on the value of three other material properties (Sansalone and Carino 1991)

$$V_P = \sqrt{\frac{E(1 - \mu)}{\rho(1 + \mu)(1 - 2\mu)}} \quad (E1)$$

where E is Young's modulus of elasticity,  $\mu$  is Poisson's ratio, and  $\rho$  is the mass density. Typically, Poisson's ratio is 0.2 for concrete. The shear and

Rayleigh wave velocities are typically 61 and 56 percent of the compression wave velocity for concrete, respectively.

## Reflection, Refraction, and Mode Conversion

Mode conversion (one wave type partly or completely changing to another) can occur when the propagated wave obliquely encounters an interface where

$$\frac{\sin \theta_{1P}}{V_{1P}} = \frac{\sin \theta_{2P}}{V_{2P}} = \frac{\sin \theta_{2S}}{V_{2S}} = \frac{\sin \theta_{1S}}{V_{1S}}$$

the acoustical velocity of the second material varies from that of the first material. See Figure E1. Snell's law can be used to calculate the angles of reflected (turned back) and refracted (turned aside) mode-converted waves:

where

$\theta_{1P}$  = angle of incident and reflected primary wave with the normal in material 1

$\theta_{2P}$  = angle of refracted primary wave with the normal in material 2

$\theta_{2S}$  = angle of mode converted refracted shear wave with the normal in material 2

$\theta_{1S}$  = angle of mode converted reflected shear wave with the normal in material 1

$V_{1P}$  = velocity of primary wave in material 1

$V_{2P}$  = velocity of primary wave in material 2

$V_{2S}$  = velocity of shear wave in material 2

$V_{1S}$  = velocity of shear wave in material 1

For incident waves normal to an interface, the coefficient of relative reflection is given by: (McMaster 1959),

$$R_n = \frac{Z_2 - Z_1}{Z_2 + Z_1} \quad \text{where} \quad Z = \rho v \quad (\text{E2})$$

where  $Z_2$  is the impedance of the material into which the wave is traveling and  $Z_1$  is the acoustic impedance of the material in which the wave originated. The impedance of a material is equal to the product of its longitudinal wave velocity and density. Krautkramer and Krautkramer (1977) worked out the mathematical relationships for the reflection coefficients of mode converted

waves for angles other than normal for plane waves incident on plane boundaries.

## Attenuation from Scattering

Concrete is very attenuative at higher frequencies, primarily because of the extensive degree of reflection and refraction that occurs at paste-aggregate interfaces. The wavelength and grain size can be compared with each other to estimate the degree of scattering, the effect causing this attenuation. The wavelength ( $\lambda$ ) is calculated by the relationship (McMaster 1959):

$$\lambda = \frac{C}{f} \quad (\text{E3})$$

where  $C$  is the velocity of propagation of the stress wave in the material of interest (concrete) and  $f$  is the frequency of the wave. The following equation from Krautkramer and Krautkramer (1977) relates the final sound pressure ( $P$ ) to the attenuation coefficient ( $\alpha$ ), initial pressure ( $P_0$ ), and propagation distance ( $d$ ).

$$P = P_0 e^{-\alpha d} \quad (\text{E4})$$

Minimal scattering will occur when the wavelength is much larger than the grain (aggregate) diameter. This is called the *Rayleigh* region, and the attenuation coefficient for this region is proportional to the fourth power of frequency times the third power of the grain diameter.

The *stochastic* region occurs when the grain diameter is approximately equal to the wavelength. The attenuation coefficient is proportional to the second power of frequency times the grain diameter for this region.

When the grain size is much greater than the wavelength, the scattering region is called *diffuse*, and the attenuation coefficient is inversely proportional to the grain diameter (Wiberg 1993). For concrete, the attenuation coefficient can vary from 30 to 300 db/m, depending on the frequency and concrete properties.

Locally obtained rock is typically used for the coarse aggregate, so there are wide variations across the country with respect to aggregate type, size, and smoothness, all of which affect the characteristics of the backscattered energy. Kozlov, as documented by Wiberg (1993), measured attenuation coefficients as a function of frequency for several sizes and types of aggregate. His results showed aggregates of 20-mm-diam limestone to be much more attenuative than 20-mm-diam granite. To the authors' knowledge, no studies have been

performed quantifying the relationship of aggregate shapes with the degree of scattering.

Scattering is a difficult obstacle to overcome in testing concrete structures with ultrasonics. To reduce false alarms (an echo, but not from a crack) created by grain backscatter and to maintain a sufficient amplitude for the propagated wave, it is a good idea to keep the wavelength approximately equal to or greater than the grain size. A good analogy for the effect of scattering is driving at night in fog. The light from the headlights reflecting off the water particles in the air will often blind the driver from seeing what lies beyond (Krautkramer and Krautkramer 1977).

## Other Sources of Attenuation

Absorption and divergence (beam spreading) also cause attenuation of propagated waves. Absorption refers to the direct conversion of sound energy to heat. It can be compensated for by increasing the amplification or transmission power or by exploiting lower frequencies, which absorb energy more slowly. Absorption does not degrade the signal-to-noise ratio, except possibly from amplifier limitations, so it is of less concern than divergence and scattering.

Simply stated, divergence refers to the increase in a cross-sectional area of a propagating beam with travel distance. The angle of divergence for a rectangular radiator is given by Krautkramer and Krautkramer (1977) by the equation:

$$\gamma = \arcsin\left(\frac{\lambda}{D_1}\right) \quad (\text{E5})$$

where  $\lambda$  is the wavelength and  $D_1$  is the length of the side of interest of the transducer. This relation is derived from the theory of diffraction. Rectangular reflectors will therefore have two angles of divergence, whereas circular reflectors will have only one. For the ideal case of a plane wave, there is no beam spreading (zero degrees of divergence). To be specific, if the angle of divergence is to be kept small (plane wave), the frequency of operation should be high or the transducer area should be large, or both. In reality there must be a trade-off when dealing with concrete as a material. Scattering limits the frequency to no more than about 200 kHz for the frequency of operation. The inefficiency of manipulating a large-area transducer in the field limits its area.

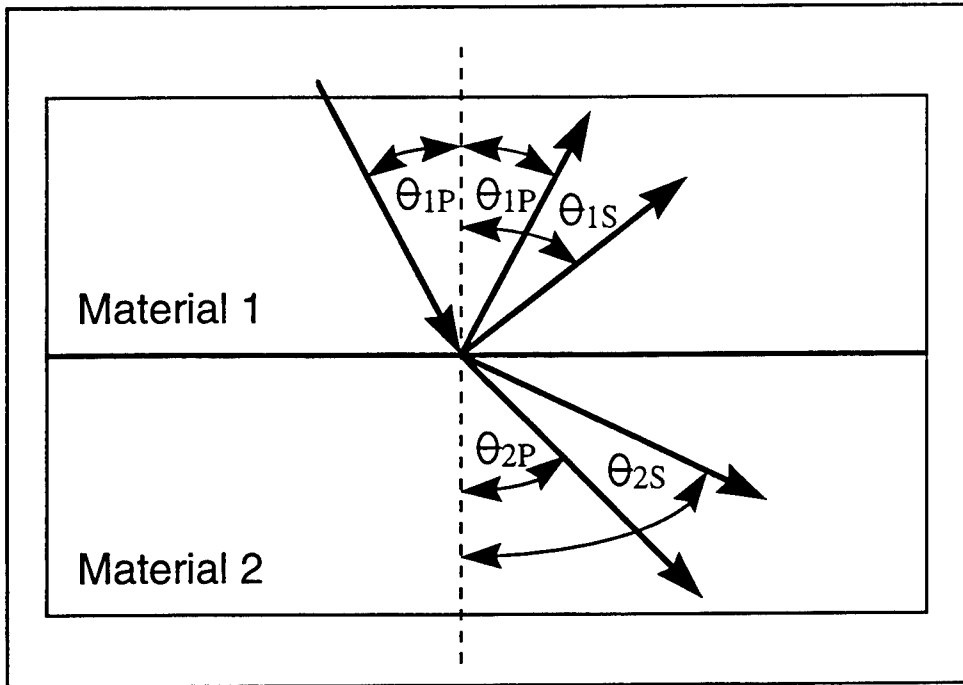

Figure E1. Mode conversion of incident P-wave at the interface of two materials

# Appendix F

## Contrast of Rolling-Pond and Sliding Systems

---

### Introduction

The rolling-pond couplant system can be compared and contrasted with a sliding couplant system developed for metal pipe. The following material explains why existing techniques described in the literature were not suitable for concrete surfaces and a different technique had to be developed (reference Nugent's patent (Nugent 1996<sup>1</sup>)). Nugent's device was developed for the same purpose that the rolling pond was developed — to make the ultrasonic measurements faster than was possible with the use of conventional systems. The sliding system was developed to diagnose boiler pipes, while the rolling pond was developed to diagnose concrete bridge decks. The boiler of a mid-size turbine generator of an electric power-generating plant may have 50 miles of pipe. Nugent's device uses water as a couplant material for the mechanical transfer of ultra-high-frequency energy that passes from the transmitting transducer to the metal pipe and the echoes that return through the couplant water to the receiving transducer. The aqueous couplant of the sliding system is a thin film of water under pressure rather than a thick aqueous layer supported by its weight as in the rolling-pond system. Pipe is smoother than a concrete surface, permitting a thin gap between the transducers and the metal pipe. Water is fed under pressure to the space between the cylindrically curved transducer surfaces and the outer surfaces of the boiler pipes.

### Pressure Unsuitable

Sliding systems with pressurized water are not suitable for concrete. The rolling-pond system does not rely on a constant flow of pressurized water to serve as the coupling agent. For pressurized systems, the water is constantly

---

<sup>1</sup> References cited in this appendix are located at the end of the main text.

being lost because it flows out of the volume between the transducer and specimen and out of the scanning assembly. Some couplant systems use either the natural fluid surface tension that is applicable only for very thin couplant layers or high fluid flow rates. With the rolling pond, a novel means has been developed by which the aqueous coupling agent is carried across a horizontal concrete surface with the scanning assembly and does not have to be constantly replaced. The system employs a foam rubber gasket that rolls over the concrete surface with minimum friction applied to the gasket. Testing has shown that this gasket will not wear like a sliding gasket or boot will. The benefits of this unique rolling gasket system are as follows:

### **Variable gap not possible**

The sliding system is not flexible enough to permit a variable gap between the transducer and concrete surface. If a sliding couplant system is being used on a test specimen with a rough surface (such as concrete), the gap between the transducer and specimen will have to be increased significantly to prevent the transducers from striking or dragging across high points on the concrete surface. The rougher the specimen surface, the larger this gap will have to be. The larger this gap, the more water that will be lost from the coupling region between the transducer and test specimen for sliding systems. Higher water pressure would be required to replace the increased water volume being lost, and this requirement would likely cause other problems, such as mechanical vibration of the transducer or even lifting the spring-loaded transducers from their reference (resting) position. Furthermore, the use of a fixed baffle such as a gasket mounted directly to the transducer or scanning assembly to direct the fluid will wear excessively as the roughness of the test specimen increases because the gasket will have to slide across the specimen, as opposed to the rolling-pond system, which allows the gasket to move by rolling with respect to the specimen.

### **Variable gap possible**

The flexibility of the rolling-pond system permits a variable gap between the transducer and concrete surface. The rolling-pond system does not lose additional water as the transducer/specimen gap is increased because the water is transported in the fluid-sealing roller-traction system. Field tests have been performed with the rolling-pond system with transducer/specimen gaps as large as 1 in. (25 mm), and it is believed sliding systems would become completely impractical for gaps even a fraction of this size. A sliding system requires that the surface must first be cleaned to produce a semi-smooth surface. The rolling-pond system does not suffer from such a limitation and has successfully tested very rough concrete surfaces without a continuous source of water from an external water supply.

### **Accommodates large-area transducers**

The rolling-pond system accommodates transducers with large surface areas. Test materials that are either inhomogeneous or highly attenuative, such as concrete, often require transducers with large areas. As the area of sliding transducers is increased, more water (coupling fluid) will be lost from the perimeter of the transducers. A stationary baffle (or gasket) such as could be implemented with a sliding system will suffer from increased drag and wear because more gasket perimeter is needed to cover the larger transducer area. The rolling-pond coupling system is not sensitive to the transducer area, nor will the fluid-sealing roller-traction system suffer increased drag or wear as its size is increased. The current transducers used with the rolling-pond system are 20 in.<sup>2</sup> (1,290 mm<sup>2</sup>), which are significantly larger than those used for testing metals. Transducers for testing concrete, that is by nature inhomogeneous and highly attenuative, have been built as large as 75 in.<sup>2</sup> (4,838 mm<sup>2</sup>) (Mailer et al. 1970).

### **Pressure causes turbulence**

Higher pressure causes turbulence, which causes low-frequency noise. Inhomogeneous or highly attenuative test materials (concrete, cast iron, etc.) must often be tested with low-frequency ultrasonics because high-frequency ultrasonics are scattered and attenuated excessively by the large grains in such materials. (See the section "Attenuation from Scattering" in Appendix A.) As an example, most ultrasonic systems for metal operate in a frequency range from 5 to 10 MHz, whereas concrete is often examined in the frequency range of 50 to 200 kHz. If a sliding system for metal or concrete were to be operated in the frequency range of the rolling-pond system (10 to 300 kHz), coupling by means of high pressure would create a large amount of noise due to water pressure variations and turbulence. The rolling-pond system allows laminar flow of the coupling agent (water) between the transducers and specimen so that noise from turbulence is not present. Because the water is not forced and generally not externally supplied, pressure variations, such as those originating from a water pump, turbine, or other noise source, are also not present.

### **Vibration reduced**

A large area of foam support is beneficial in reducing vibration and maintaining a constant gap. The fluid-sealing roller-traction system is covered with a soft closed-cell foam rubber, which serves to support the entire scanning assembly. The material deflects about 1/4 in. (6 mm) from the 400-lb (181-kg) weight of the metal frame. This large area of foam-rubber-based support damps out vibrations that would otherwise occur when traversing rough surfaces with a device such as a sliding system. With a sliding system device, rough surfaces would generate vibration of the main supporting wheels in which the ultrasound would easily travel undamped through the chassis to the transducer

in the low-frequency ultrasonic range, as described previously. If the sliding system had wheels made out of soft foam or rubber to overcome these vibrations, it would lose the means by which the transducer specimen gap is maintained constant. The rolling-pond device is able to sustain a constant transducer/specimen gap because of the large contact perimeter of the roller-traction system.

### **Independent adjustment of parameters**

The rolling pond permits an independent adjustment of important transducer variables. The rolling-pond system provides for greater transducer flexibility than a sliding system. The transducer suspension system of the rolling-pond device is mounted to the roller-traction system and allows for independent adjustment of different variables: the horizontal transmitting and receiving transducer positions, elevations, and angles. This allows the same transducers to be used over a wide range of specimen properties such as thickness or acoustic impedance. This flexibility also allows for optimizing received reflections, and hence improving the signal-to-noise ratio. A sliding system design would not allow for independent variation of these variables. When sliding systems are used to evaluate metal pipes, different transducer shapes must be used with different pipe diameters.

### **Piezoelectric connections**

The following describes the electrode connections of the piezoelectric elements. The electrodes are located on the top and bottom surfaces of the piezoelectric plate elements. Both electrodes of the piezoelectric elements must be connected to the pulser for proper transducer operation. The bottom electrodes of the piezoelectric elements are connected to the top surface of the lead-glass plate (quarter-wave matching element) with a conductive epoxy, and then connecting wires are soldered to the gold foil on the lead glass. On the top surface of the piezoelectric elements (the top electrode), conductive epoxy is used to connect the wires directly to the piezoelectric components.

### **Function different with rolling pond**

The functionality of the rolling pond is different from other systems. While the sliding system and the rolling pond may use similar terminology in describing some of their system components, there are drastic differences in functionality and approach. The following states the advantages of the rolling-pond system in overcoming limitations inherent in a sliding-system design.

## **Unique system**

The rolling-gasket system is unique. The sliding system supplies a constant flow of water that fills the space between the transducer and test specimen. This approach is common and has also been described by Olson et al. (1995) and others in the literature. The roller-traction system (i.e., rolling pond) does not require this constant supply of water. The rolling-pond system seals this water between foam-covered belts on either side of the transducers and between the foam-covered metal-rollers in front of and behind the transducers so the coupling fluid is literally carried across the horizontal test specimen. These rollers and belt elements are covered in soft-foam sponge rubber and form a watertight seal with each other as they move over the test specimen. Additionally, when the device is moved during scanning of the concrete surface, there is no material loss of the sealing elements due to friction with the specimen surface or each other. Other benefits from the rolling-pond system include larger transducer/specimen gaps, laminar couplant (water) flow under the transducers, improved testing of porous materials with an air-removal brush, and increased couplant depth.

## **Constant gap**

The rolling-pond design permits the transducer/specimen gap to remain constant. The rollers used by the metal system in Nugent's system are for the purpose of maintaining a constant specimen/transducer gap. The rolling-pond device uses the entire belt and roller perimeter to maintain the specimen/transducer gap. This is an improvement because it prevents this gap from changing when small surface irregularities are traversed. In addition, the foam-covered rollers of the rolling pond provide shock and vibration isolation when traversing rough surfaces. This is accomplished by the layer of ethylene propylene diene rubber and soft closed-cell foam sponge rubber that cover the steel roller and the belts. This soft material covering the rollers also serves to help form a watertight seal with concrete specimen.

Nugent's sliding system uses commercially available transducers. The rolling-pond transducers are unique and not commercially available.

## **Barrier different**

The barrier described by the metal system serves a different purpose than the isolation device described for the rolling pond. The barrier for the sliding transducer is built into the transducer and serves only to reduce ultrasonic coupling in the transducer housing. This is common practice for high-frequency transducers that house both a transmitting and receiving element. The rolling-pond isolation device is not part of the transducers and is independently spring loaded to contact the surface and therefore reduce ultrasonic coupling through the couplant layer. The lower section of the rolling-

pond isolation device is composed of a foam-rubber strip, which is replaced when frictional wear deems it necessary. The barrier present in combined transmitting and receiving transducers serves the same function as the air gap between the two transducers of the rolling-pond transducer. If the frequency of operation of the sliding transducer were to be modified to operate in the frequency range (200 kHz) of the rolling pond, then cross coupling would become a problem because of the decrease in directivity of the ultrasonic energy.

### **Sliding system not sealed**

Nugent's sliding system for metal does not provide a seal between the transducer and specimen (Nugent 1996). The sealing described by Nugent's metal system in drawing elements refers to sealing of the water between the remote pump and the delivery to the probe outlets in a hose-type assembly. Note that the metal system basically sprays the specimen surface with the water. There are many commercial systems available that have used this approach. Unlike the rolling-pond approach, spray-type systems are not practical in the middle to low kilohertz frequency range. The metal system does not give any detail or describe any components for sealing between the transducer units and the specimen, so it is assumed it relies on hydrostatic pressure and surface tension to form a thin aqueous film. The metal system could use a transducer-mounted boot to increase the sealing capability; however, this would create additional problems. The sealing limitations of the sliding device are further discussed in the limitations section in Nugent (1996). Note that the rolling pond system seals the water in the volume labeled by 42 and 50 in the drawings. This volume is sealed by the belts and rollers shown in Figure 9 (in main text). Additionally, pulleys help maintain the integrity of the seal along the length of the belts over rough and uneven surfaces.

### **Significant differences**

There are significant differences between the rolling pond and Nugent's sliding system for metal. The rolling-pond transducers are planar based, unlike the sliding system. The rolling-pond transducers can also be independently varied in angle, horizontal position, and elevation. The sliding transducers can be varied only in elevation as a pair. The wedge described by the metal system is different in geometry from the wedge described by the rolling-pond system. This transducer wedge angle is selected to test nominal thicknesses of concrete slabs such as bridge decks. The rolling-pond transducers overcome surface wave problems by using a large-area receiver. This is not an issue for the metal system because they operate at a higher frequency range for metal inspection.

## **Advantage of large-area coupling**

Large-area coupling has some advantages. As stated in the rolling-pond patent application, Olson's system (Olson et al. 1995) is able to couple only to a line or a point on the specimen surface (limitations of a wheel transducer). It is also stated in the limitations section of this document that the metal system is not able to achieve effective coupling of very large-area transducers due to limitations of their coupling approach. Because the rolling-pond system is able to couple large-area transducers to the specimen surface, it is better suited to testing inhomogeneous materials such as concrete with impact echo. Coupling a point, line, or small area with an inhomogeneous specimen results in increased scatter because only a few incoming rays are collected (acoustical energy is often modeled as rays normal to the propagating wave front). Coupling to a large area such as achieved by the rolling pond collects many incoming rays so the influence of the material inhomogeneity is decreased. A further benefit of a large-area receiving transducer is that material attenuation effects are reduced.

## **Air brush**

An air brush serves a unique purpose. The rolling-pond system does not use the described brush for cleaning debris from the surface. In testing with the rolling-pond device, the surface is swept clean of debris with a standard push broom before testing begins. The purpose of the spring-loaded brush in the rolling pond is to remove entrapped air from the specimen surface. When water is initially placed on the surface of a specimen such as concrete, numerous minuscule air bubbles will adhere to that surface. These bubbles are visible only at eye level with the specimen. Given sufficient time, usually a few hours, they will dissolve or break free on their own. The rolling pond brush physically sweeps these air bubbles off the specimen surface. When the brush strikes these small bubbles, they join together into larger bubbles and then quickly break free and rise to the surface. Tests have shown that removal of these bubbles from the surface of concrete produces up to a 70-percent increase in the received ultrasonic signal. McMaster (1959) diagnosed that this attenuation was due to entrained air (not sweepable). Researchers at the U.S. Army Engineer Waterways Experiment Station (WES) discovered that this attenuation was for the most part due to entrapped air.

The rolling-pond system is the first one to develop a rapid and portable planar-based ultrasonic pulse-echo scanning system suitable for concrete (i.e., rough inhomogeneous materials).

## **Other approaches not practical**

Prior methods of coupling a large-area transducer to a concrete surface for ultrasonic pulse-echo measurements relied on either the use of a thick material such as coupling grease or, less commonly, flooding the specimen to be

examined. Of these two approaches, only flooding allows scanning of the test specimen. In flooding, a rectangular barrier is sealed to the horizontal specimen surface with silicon caulk or clay; water is then poured inside the barrier. However, flooding is typically not applied for the following reasons:

- a.* Setup and takedown time is too long.
- b.* Specimen slope (grade) variations limit the test area.
- c.* Scanning distance is limited per setup position.
- d.* Water is lost through cracks and joints.
- e.* A large volume of water is needed.

These factors make it impractical to flood concrete structures such as bridge decks and runways. WES researchers have developed a system that can be quickly deployed onto a horizontal concrete structure. Since a continuous water supply is usually not available on these type of structures, the conservative use of water by the rolling-pond system is an important benefit. In field tests, the rolling-pond system has demonstrated its high resolution by detecting smaller flaws that were missed by experienced chain-drag operators. The real-time continuous scanning capability makes this approach faster than all other techniques except radar and thermography and more efficient. The resolution of the rolling-pond system is superior to all other one-sided testing techniques for concrete. The rolling-pond system should advance nondestructive testing for applications such as bridge decks, runways, pavements, foundations, parking garages, etc.

# Appendix G

## Split-Spectrum Processing

---

### Introduction

To understand split-spectrum processing (SSP), one needs to understand a few things about digital information and digital signal processing (DSP).

#### Digital

Information that is *digital* is represented by numbers (digits) or, more broadly, can be measured in discrete, exact values. The opposite term is *analog*, which describes information represented along a continuous range, where there are an infinite number of possible values. *Analog* refers to things that are in a continuous flow or that have an infinite number of values — things that are analogous to real life. The best way to understand the difference between digital and analog is to compare a digital clock to a traditional round clock with hands. The display on a digital clock always shows one particular time, in numbers. A clock with hands, in contrast, is an analog device because the hands move along the entire circle of the clock face; at any one instant, the hands can be anywhere on the clock, displaying an infinite number of moments in time. All common computers work only with numbers and are digital devices.

#### Digitize

If an individual wants to use a computer to work with information from the natural world, which is almost entirely analog, the analog information must be converted to digital form. That is, the information must be digitized. The qualities of the natural world — attributes like temperature, time, length, color, and the pitch of sounds — vary continuously over an infinite range of possible values. To digitize means to represent something that occurs in this infinitely variable (analog) form as a series of concrete, countable numbers.

Any information that has been digitized contains only a sampling of the original information. Still, if there are enough samples and if they are detailed enough, the reconstituted information can seem like the real thing. For example, the quality of a scanned, digitized photograph depends on how many gradations of light intensity the scanner can distinguish and how small the dots are on the imaginary grid (Williams 1993<sup>1</sup>).

## **Digitizer**

When an individual has an image outside the computer, like a photograph or a drawing on paper, and wants to use it inside the computer, the image needs to be *scanned*. A *scanner* is a device that takes a picture of the image, digitizes it (breaks it up into dots that can be recreated on the computer screen with electronic signals), and sends this digital information to the computer. Once this scanned image is in the computer, it can be viewed in different sorts of applications and changed. Also, DSP algorithms can be applied to the sequence of numbers so that certain components of the signal can be emphasized while other are deemphasized.

## **Processing**

Processing is the additional handling, manipulation, consolidation, compositing, etc., of information to change it from one format to another or to convert it to a manageable and/or intelligible form (Graf 1974-75).

## **Digital signal processing (DSP)**

DSP refers to the conversion and analysis of nondigital information by digital means. The idea is that something real such as music or the human voice can be taken and digitized (converted into numbers or into something the computer can understand) and then the power of the computer can be used to analyze it.

DSP is concerned with the representation of signals by sequences of numbers or symbols and the processing of these sequences. The purpose of such processing may be to estimate characteristic parameters of a signal or to transform a signal into a form that is in some sense more desirable. The classical numerical analysis formulas, such as those designed for interpolation, integration, and differentiation, are certainly DSP algorithms.

As stated by Oppenheim and Shafer (1975), "Signal processing, in general, has a rich history, and its importance is evident in such diverse fields as

---

<sup>1</sup> References cited in this appendix are located at the end of the main text.

biomedical engineering, acoustics, sonar, radar, seismology, speech communication, data communication, weather satellites, nuclear science, and many others.”

There are two general areas: digital filtering and spectral analysis.

### **Television**

DSP can be used to compensate a signal for losses resulting from distortion, fading, and insertion of background noise subsequent to transmission of the signal over some distance. In digital television, the composite signal is separated into an audio channel and a video channel by digital filters. Ghosts are removed with digital processing. The power-line flicker at 60 Hz is suppressed by DSP.

### **Telephone**

In digital telephony, sharp cutoff digital filters are used to separate the voice signal from undesirable signals or noise. Transmission loss and attenuation are compensated for by digital filters acting as equalizers. Gain and echo cancellation are also performed by DSP. The 60-Hz hum is suppressed, and the low-frequency dial tone is attenuated. Numerous other applications could be mentioned in biomedical, seismic, and other scientific and engineering fields (Bose 1985).

## **Ultrasonic Pulse Echo (UPE)**

Many times and in the case of UPE for concrete, the signal will originate as an analog signal; i.e., it is continuous in the time domain. To take advantage of the benefits of DSP, the signal must be digitized (quantized to a discrete set) by sampling the signal. Every one is familiar with the plotting of a few discrete points to represent a continuous function, for example. Analog signals are said to exist in the continuous time domain, while digital signals are said to exist in the discrete time domain.

Signal enhancement is an important function of DSP routines. Examples of DSP include signal averaging, filtering, spectral analysis, feature extraction, and others. A major aspect of signal processing includes monitoring, analysis, interpretation, and validation of signals.

The UPE system receives an analog signal that excites the transmitter, and it delivers an analog mechanical wave to the concrete. The analog echo is received by the receiver and converted into an analog voltage having the same pattern as the mechanical echo. That signal is then digitized and stored in the computer memory for analysis.

## History and Function

SSP was introduced in the late 1970's in an attempt to implement frequency agility techniques, originally used in radar for signal-to-noise ratio improvement, for ultrasonic signals (Karpur et al. 1987). When SSP is performed successfully, reflections from backwalls and flaws will remain while reflections from grain or aggregate will be removed or reduced.

### Processing parameters

The upper and lower cutoff frequencies are important parameters that must be determined when implementing SSP. An important criterion for applying most of the recombination techniques is that the target echo exists across the entire selected frequency range. Rayleigh scattering from grains tends to contribute to upward frequency shifts, while reflections from large flaws are typically shifted downward in frequency because of attenuation filtering. Other effects, as well as transducer responses, should be considered when selecting the frequency range. The selected frequency range of bandwidth ( $B$ ) is split into  $N$  overlapping Gaussian filters. One possible value for  $N$  is given by the following equation:

$$N = B * T + 1 \quad (G1)$$

This equation gives the total number of filters  $N$  as a function of the selected bandwidth  $B$  and total time  $T$  of the signal. The frequency of separation for the Gaussian filters is then given by one over the total time of the signal being processed (Karpur et al. 1988). The bandwidth of the Gaussian filters is then typically chosen to be about four times the frequency of separation (Ausserl 1990). Bandpass finite-impulse-response filtering is then performed in the time domain by convolving the raw signal with wavelets whose Fourier transforms are the  $N$  Gaussian filter banks described previously. The resulting signals can then be normalized (maximum value converted to value of one) and squared.

### Minimization technique

The power of SSP lies in the recombination techniques. For a signal to be recombined, a specific criterion is applied to the  $N$  signals at each point in time. If the mean is chosen as the recombination criterion, the resulting signal will match the original signal filtered over band  $B$ .

The minimization technique, whose performance generally tends to improve with the number of filters, recombines the split signals by selecting the minimum of the absolute value from the  $N$  signals at each instant in time. This technique is used because grain reflections tend to be less uniformly distributed

across the split spectrum than reflections from flaws. In other words, a flaw or backwall reflection will tend to produce an amplitude distribution over all  $N$  signals at its arrival time, while grain noise will be more frequency dependent (Newhouse et al. 1982). The success of this technique depends on the target information existing over the entire band  $B$ . If this does not exist, then a more robust operator must be used (Sannie, Nagle, and Donohue 1991).

### **Polarity thresholding**

A nonlinear algorithm called polarity thresholding can be used in conjunction with other techniques such as minimization or on its own. Polarity thresholding assumes that since a flaw reflection will be more consistent in polarity than grain noise, no polarity reversals should occur at the instance of a flaw reflection. The recombination criterion is as the follows: if a time instance in a split spectrum does not contain a polarity change, it should be included in the composite; else, a zero is used at that instance (Bilgutay et al. 1990).

### **Order-statistic filters**

Minimization falls under a class of filters called order statistic. These filters were developed in the statistics field and have the ability to emphasize statistical separation between samples belonging to different hypotheses (Sannie, Donohue, and Bilgutay 1990). Implementation of order-statistic filters for recombination starts by sorting the  $N$  values at a given instance in the split-spectrum matrix. If the center value of the  $N$ -sorted signals is extracted for composite, then a median operator is implemented. An example of another rank would be extracting the maximum value. For further information on order-statistic filters applied to SSP, refer to Sannie, Nagle, and Donohue (1991).

# Appendix H

## Artificial Neural Networks

---

### Interpretation of Signals

Artificial neural networks (ANNs) can be used to interpret data (Alexander and Haskins 1998<sup>1</sup>). One or more networks can be trained to associate certain signal features with certain types of physical deterioration in the concrete. Measurement criteria were to be developed on the physical models, and the physical models were to be used for training the ANN algorithms.

The output of the analysis table will be the input for the ANN algorithms. The ANN can give a computer interpretation of one signal at a time. The default presentation will be a plot of all signals against position.

### Brain-Style Computing

ANNs are processing devices that are either algorithms or actual hardware. The operation of an ANN can be simulated on a standard computer (Von Neumann computer) using algorithms. A standard computer has one central processing unit; a neurocomputer would have many processing units that operate in parallel similar to the human brain. The processing on a standard computer would take longer than on a neurocomputer but would still be capable of solving problems. ANNs are sometimes referred to as brain-style computing devices. ANNs consist of a network of artificial neurons just like the brain consists of a network of brain cells (neurons). They mimic people in that people tend to learn from examples rather than explicit rules. Neural networks generate their own rules by learning from examples. In contrast, expert systems require that all rules be provided by the programmer. Learning is analogous to being programmed in standard computing.

---

<sup>1</sup> References cited in this appendix are located at the end of the main text.

## **ANNs Ideal for Complex Relationships**

ANNs are computing devices for performing numerical modeling. ANNs are not constrained by an *a priori* assumption as to the functional form (linear or nonlinear) of the relationship. ANNs have been found to be useful for analyzing complex relationships involving a multitude of variables. ANNs explore many competing hypotheses.

### **ANNs do not need rules**

A significant area of research in engineering is to find solution procedures for various problems and create computer applications for solving those problems. Standard computers need explicit rules (logical statements of instructions) to solve problems. When it is difficult to specify rules for certain problems, those applications cannot be computerized with traditional computers. Signal recognition is a difficult problem for standard computers.

The U.S. Army Engineer Waterways Experiment Station (WES) has not completed the task of developing the measurement criteria and therefore has not trained the ANN algorithms. However, WES has found the ANN to be useful for ultrasonic pulse-echo (UPE) signal recognition (Alexander and Haskins 1998).

### **Fabricating deterioration standards**

A chemical expansive agent was introduced into a concrete mixture, and five concrete specimens were placed and cured under warm, moist conditions. The ultrasonic pulse velocity (UPV) was measured daily to detect the onset and degree of cracking. One specimen was placed without the chemical expansion agent to serve as a control. After about 7 weeks, each of the five specimens had experienced microcracking but at different rates and different amounts. All five specimens were removed from the warm, moist conditions and placed in a 72 °F room at normal humidity. After about a week, the UPV of each specimen stabilized to a constant value, indicating that the expansive reaction had stopped.

### **Acquiring measurement data**

Nine locations on each of the six specimens were grided for taking UPE measurements. Four UPE measurements were taken at each of the locations by rotating the transducers 90 deg each time to average out the coupling factor. (The coupling can be variable as the surface of the concrete is rough and some type of coupling grease must be used between the transducers and the concrete surface to replace the air layer.) At each location, a UPV measurement was made to index the degree of cracking at a given location. This consisted of 216

UPE measurements and 54 UPV measurements. One-hundred-eighty-six UPE measurements were set aside for the ANN training, and the remaining thirty measurements were reserved for testing the performance of the trained network. The UPE signals served as the input to the ANN, and the UPVs served as the target values for the ANN for the training process.

### **Preprocessing of data**

A commercial ANN software package (Demuth and Beale 1992) was used to perform the correlation of the UPE data to the UPV data on an IBM-compatible personal computer (PC). The amount of data was excessive for the PC as each UPE signal contained 2,048 points. See Figure H1 for a typical signal. Through visual observation of the data, it was noted that the total reflected energy was lower for the specimens possessing the greater deterioration. Also, it was noted that the higher frequencies were attenuated more than the lower frequencies for the specimens of greater deterioration. A power spectral density curve was calculated for each raw signal, and that signal was mathematically integrated to obtain the cumulative reflected energy. Typical signals can be seen in Figure H2. Note that the total cumulative energy is 12.5 j for the sound concrete and only 0.2 j for the microcracked concrete. The sound concrete returns about 60 times more energy than the deteriorated concrete. Also, note that the curve from the sound concrete consists of low and high frequencies, but the curve from the unsound concrete consists primarily of low frequencies. The microcracks tend to dissipate the high-frequency energy as the wavelengths of that energy correspond to the dimensions of the cracks. By preprocessing the data, the number of points was reduced from 2,048 to 88 points without significantly sacrificing important information.

### **Training the ANN**

The back-propagation learning algorithm was used to train the ANN. The ANN used supervised training as the examples used in the training had answers. The weights and biases were set randomly on the first iteration. Thousands of iterations and hours of training were required to bring the output velocities in line with the target velocities. The training error can be observed graphically as learning takes place. Much like a person can take a few specific examples and generalize about the whole, so can the ANN mimic a person's thinking process.

### **ANN performance**

The correlation coefficient from a least-squares fit was 98.6 percent for the training data. See Figure H3. After training, the ANN was performance tested with 30 UPE signals that the model had not seen in training. A least-squares fit demonstrated that the output velocities from the ANN correlated well with the

measured (target) UPVs. The correlation coefficient was 84.8 percent. See Figure H4. The system was able to rank all six specimens in the correct order of deterioration. This investigation demonstrated that the automated interpretation of UPE signals for continuous interfaces by ANNs is feasible.

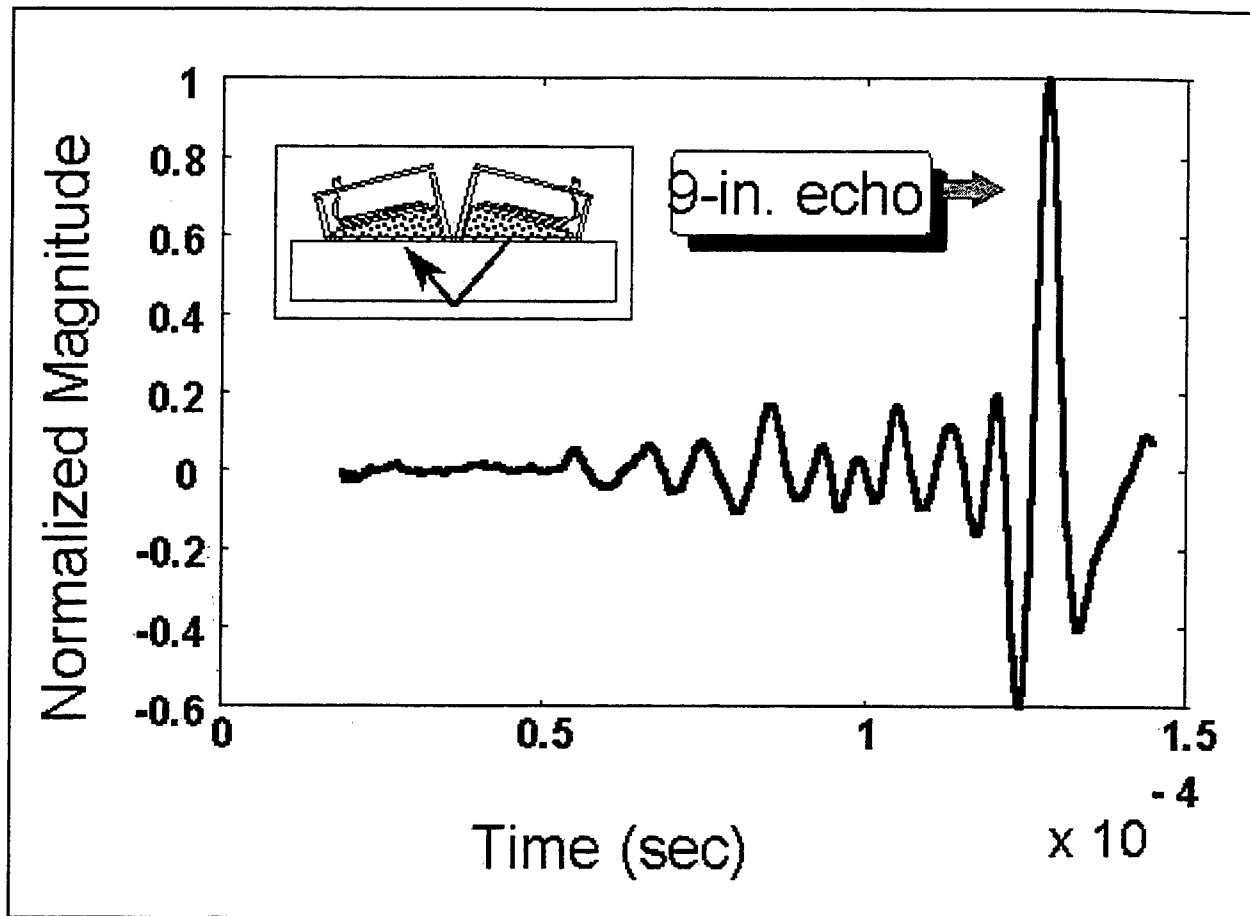

Figure H1. Typical UPE signal from the SUPERSCANNER'S 9-in.-thick test bed

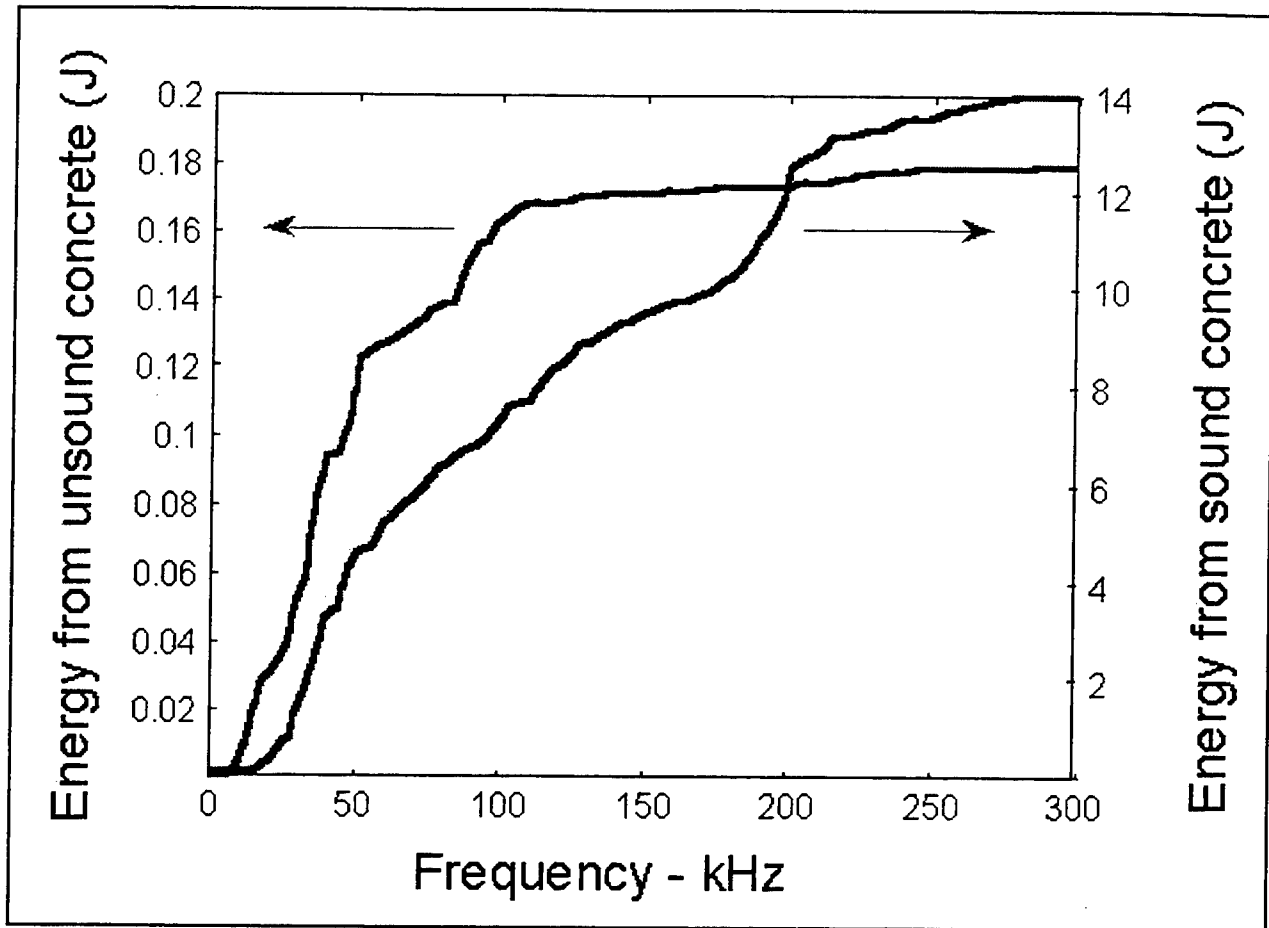

Figure H2. Two of the cumulative energy curves used as ANN inputs

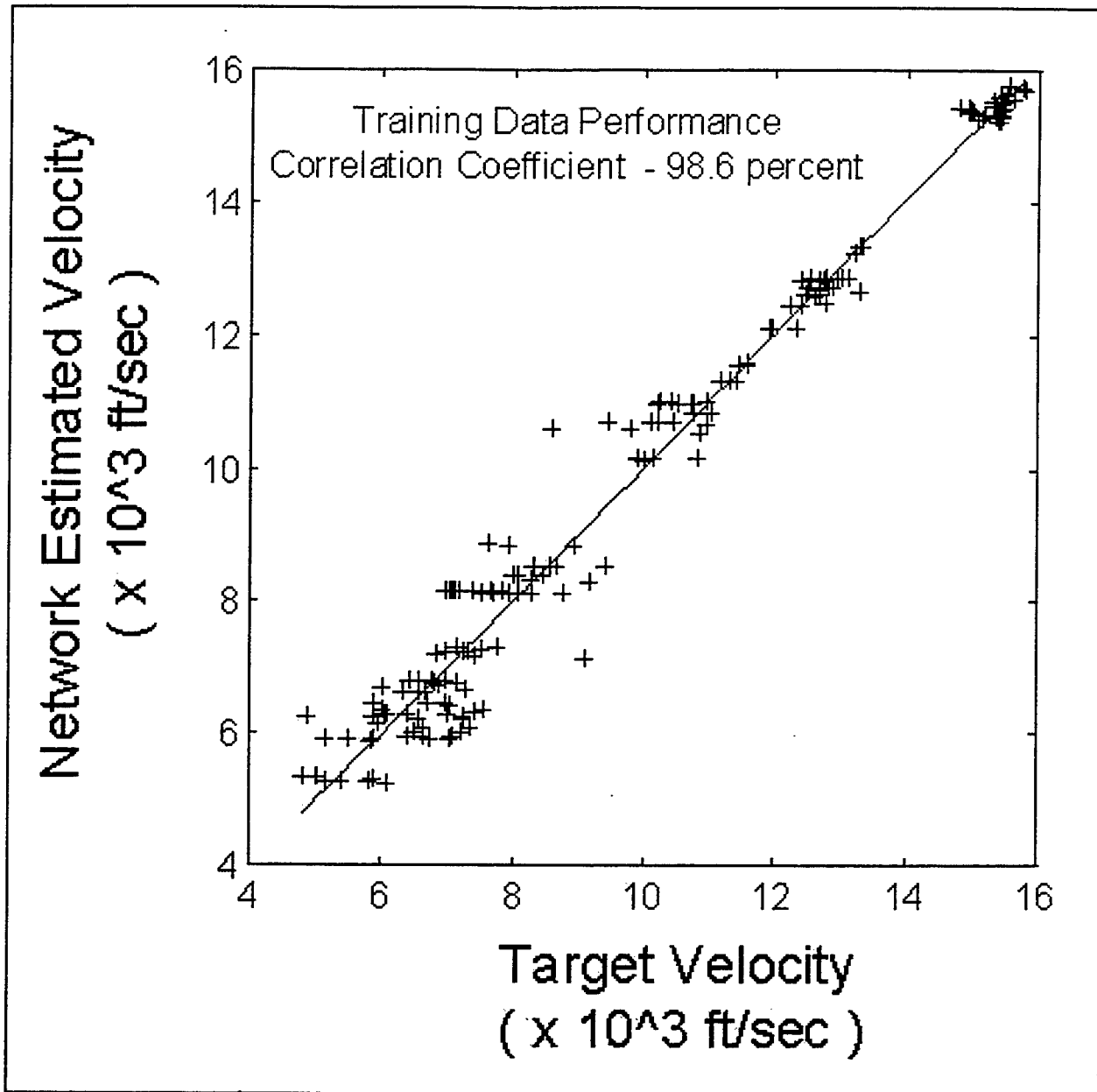

Figure H3. ANN performance on trained test data, in characterizing ultrasonic velocity on microcracked concrete

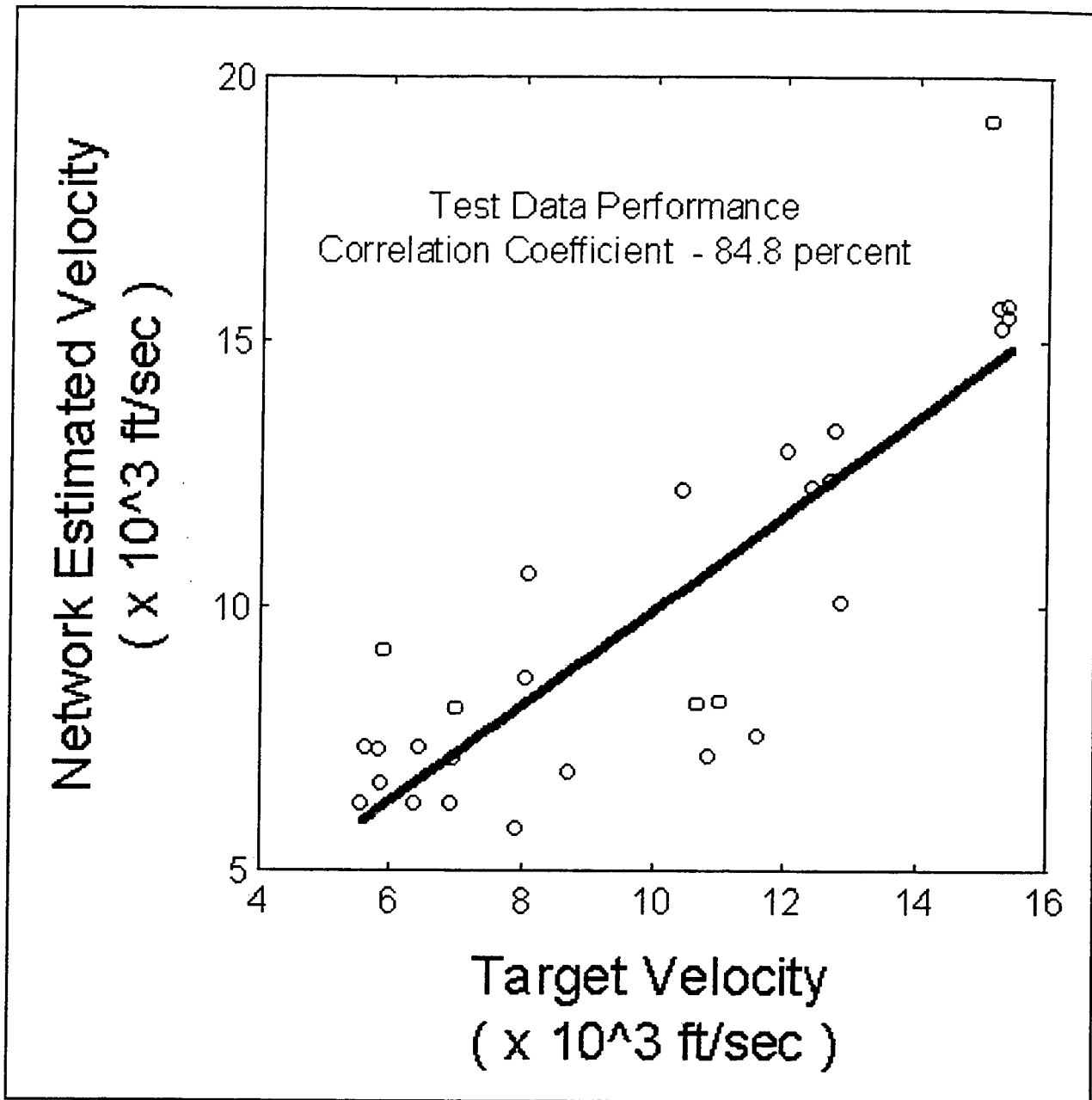

Figure H4. ANN performance on untrained test data, in characterizing ultrasonic velocity on microcracked concrete

# Appendix I

## Expert System for UPE

---

### Rapid Growth of Expert Systems

Knowledge-based expert systems (KBES's) have attained a permanent and secure role in industry. Simons noted in 1984<sup>1</sup> that such systems were moving from the laboratory stage to the marketplace, and McEwan, Abou-Ali, and Belavendram (1991) stated that "in the last decade there has been a rapid growth in the development of expert systems for engineering applications."

### Definition of KBES

An expert system is a computer program that can implement a model of the knowledge and reasoning process used by a human expert in a particular field (domain) of study. The expert in his field of expertise can be free to do other important work as the expert's thought and reasoning processes are entered into the computer and a user can consult with the computer. A KBES system can supply the advanced technology familiar only to a few highly knowledgeable and trained personnel so that the technology can be made available at jobsites across the country for use by many personnel. This is one main purpose for developing an expert system.

### Purpose of KBES's

Expert systems are ideally suited for the diagnosis of various types of systems. They can be used to guide a semi-skilled operator through a detailed test procedure for making a measurement such as an ultrasonic pulse-echo (UPE) measurement on concrete. In the field of nondestructive, expert systems may be applied to two main areas: (a) generating test procedures (equipment setup, calibration, measurement, and presentation of results, etc.)

---

<sup>1</sup> References cited in this appendix are located at the end of the main text.

and (b) analyzing test results and making interpretations on the condition of the concrete, such as for UPE measurements. In this project, the KBES was to be used to guide the operator through the test procedure. KBES's are an improvement over point-and-click icons and mouse-operated menus because KBES's keep the measurement procedure in the correct order and use the familiar English language.

## Means of Operation

The user is guided and prompted by a series of questions using user-supplied data in addition to IF-THEN rules from a knowledge base that can analyze and interpret the data. Expert systems emulate human expertise by applying the techniques of logical inference to a knowledge base. People can enter into a dialog with the computer much like interacting with a human expert. Conventional programming languages like FORTRAN, BASIC, C, PASCAL, etc., are based on arithmetic and simple algebra. KBES's are based on techniques used to prove theorems in logic. A KBES is concerned with symbolic processing rather than just numeric processing. PROLOG is a common language for coding expert systems.

## Structure of KBES's

Basically, any expert system in its delivery form contains three basic elements: (a) a knowledge base, (b) an inference engine, and a (c) user interface (Downing and Covington 1989).

- a. The knowledge base consists of everything known about the particular domain of expertise. It is called the domain or database of factual knowledge. The IF/THEN rules are entered here also.
- b. The inference engine is the part of the program that deals with the knowledge base. It searches the knowledge intelligently to pick up the appropriate facts and rules in relation to the current hypothesis. The inference engine guides the application of the facts in the knowledge base. It is able to derive new knowledge from inferring conclusions about the data.
- c. The user interface is a user-friendly computer program acting as an interpreter between the end user and the system. It is responsible for acquiring the necessary data to start and continue the consultation with the system and for displaying the results at the end of the consultation. It is important that the input and output language be naturalistic. Reasoning with defaults cuts the amount of work the end user must do to specify the system's behavior under typical circumstances. Since it is not economically feasible for an expert system to interpret a full

sentence, most expert systems ask the questions, and the user supplies numbers, names, and short answers such as "yes" or "no."

## **Expert System Shells**

Expert system shells are expert systems minus the knowledge base for a particular domain. The domain is the particular field of expertise. The shell contains the inference engine and the user-interface section. The programming has been done for the user, and he has only to supply the knowledge and rules in a particular domain to the system. An expert system tool kit is more than a shell. The tool kit makes it easier to build a knowledge base. It contains an editor for building the IF-THEN rules, a trace facility for testing how the rules interact, hooks to pre-existing databases and spreadsheets, and a sophisticated user interface that hides all of the tools from the user during run-time consultation. The U.S. Army Engineer Waterways Experiment Station (WES) planned to use the KBES-shell Level5 Object package sold by Information Builders, Inc. WES researchers also evaluated two other KBES-shell software packages.

## **Development of System**

In order to build an expert system, two main activities need to be carried out: knowledge acquisition and knowledge representation. The knowledge acquisition consists of obtaining a detailed examination of the content of the thought processes of an expert. This includes information, scientific principles, rules of thumb, and all of the inferences an expert uses to reach a decision. The difficulty in building expert systems lies in encapsulating the expert's knowledge in the computer in a form that can be used to advise the user.

## **Progress to Date**

Initial rules and facts have been developed for the KBES that will permit a technician to replace the highly trained expert to conduct the complete procedure for making UPE measurements. Preliminary coding has been accomplished on the Level5 Object KBES shell. The constituent parts of the KBES procedure for performing UPE measurements include the following activities: setup of the equipment, calibration of the concrete, measurement, analysis, interpretation, and presentation of results. Conducting the procedure does not have to be performed in a straight-line manner but can be done recursively.

## **Integration of Software**

Another significant task that was planned to be performed was the software integration. At least five commercial software packages, Level5 Object, Microsoft Visual Basic, MATLAB, HP-VEE, and Microsoft Excel, were to be integrated to operate as one package. The KBES was to be the primary interface that would control all the other packages. WES personnel are using Microsoft's Dynamic Data Exchange and Object Linking and Embedding functions to perform the integration.

# Appendix J

## Petrographic Examination of Concrete Core Samples

---

### Pre-Injection Concrete Cores

- a. *Core Sample No. S05-09101, C-1.* The vertical core sample of bridge-deck pavement concrete submitted by the Michigan Department of Transportation (DOT) measured 6.9 in. in length by 3.7 in. in diameter. The concrete was composed of 3/4-in. maximum diameter, very light gray (N 8) to light bluish gray (5 B 7/1-Munsell Color Classification), angular to subround, crushed, carbonate (limestone) coarse aggregate (Figure J1). The fine aggregate was composed of angular-to-round, natural, quartzose sand containing deleterious chert particles. The concrete was well consolidated with no indications of coarse aggregate segregation and only minor indications of overworking by the preferred orientation of some elongated coarse aggregate particles subparallel to the core top. The top surface of the core represented the bridge-deck pavement finished surface or free-face and is flat, slightly roughened, with fine aggregate protruding from the surface, with few and occasional closed surface cracks (Figure J2). The core bottom was formed by a fresh fracture surface generated by core sampling operations. Steel reinforcement bars (1/2 in. diameter) were identified at depths of 3.1 and 5.0 in. below the core top (Figure J1). Concrete paste carbonation and alteration were restricted to the core top surface and did not extend appreciably into the concrete paste, as indicated by the Phenolphthalein Test to detect calcium hydroxide. The concrete appeared to be of good quality with little evidence of concrete paste alteration or internal distress. The hydrated concrete paste was light gray (N 7) in color, moderately hard, and slightly absorptive with occasional unhydrated cement clinker. Occasional fine microcracks (Figure J3) and small quantities of alkali-silica gel precipitate were identified in the hydrated cement paste matrix based on polarized light microscopy (PLM) and scanning electron microscope (SEM) analysis. Numerous entrained air voids were identified in the concrete paste

matrix. X-ray diffraction analysis of selected paste concentrates indicated cement hydration by-products such as calcium hydroxide, ettringite, and C-S-H gel were indicated and appeared to be of normal distribution. Calcium chloroaluminate (Friedel's Salt) was also identified by the minor diffraction peak at 11.2 deg two-theta (Figure J4). See Table J1.

- b. *Core Sample No. S35-25132, C-3.* This vertical core sample of bridge-deck pavement concrete submitted by the MDOT measured 6.8 in. in length by 3.7 in. in diameter. The concrete was similar in condition to the previously described sample and was composed of 3/4-in. maximum diameter, variable-colored, subangular-to-round, natural gravel coarse aggregate. The fine aggregate was composed of angular-to-round, natural, quartzose sand containing deleterious chert particles. The concrete was well consolidated with no indications of coarse aggregate segregation and only minor indications of overworking by the preferred orientation of elongated coarse aggregate particles subparallel to the core top. The top surface of the core represented the bridge-deck pavement finished surface or free-face and was flat, slightly roughened, with fine aggregate protruding from the surface. The core bottom was formed by a fresh fracture surface generated by core sampling operations. Steel reinforcement and fractures were not identified in the sample. Concrete paste carbonation and alteration were restricted to the core top surface, similar to the previous sample, and did not extend appreciably into the concrete paste, as indicated by the Phenolphthalein Test to detect calcium hydroxide. The concrete appeared to be of good quality with little evidence of concrete paste alteration or internal distress. The hydrated concrete paste was light gray (N 7) in color, moderately hard, and slightly absorptive with occasional unhydrated cement clinker and fine microcracks (Figure J5), with cement hydration by-products such as calcium hydroxide, ettringite, and C-S-H gel in normal distribution, and entrained-air voids were numerous.
- c. *Core Sample No. SO6-09101, C-5.* This vertical core sample of bridge-deck pavement concrete submitted by the MDOT measured 6.2 in. in length by 3.7 in. in diameter. The concrete was similar in composition and condition to the previously described core sample (C-1) and was composed of 3/4-in. maximum diameter, very light gray (N 8) to light bluish gray (5 B 7/1) Munsell Color Classification, angular-to-subround, crushed, carbonate (limestone) coarse aggregate. The fine aggregate was composed of angular-to-round, natural, quartzose sand containing deleterious chert particles. The concrete was well consolidated with no indications of coarse aggregate segregation or overworking. The top surface of the core represented the bridge-deck pavement finished surface or free-face and was flat, slightly roughened, with fine aggregate protruding from the surface. The core bottom was formed by a fresh fracture surface generated by core sampling operations. Steel reinforcement (3/4-in. diameter) was identified in the

core and contained some corrosion along the steel/concrete paste interface zone. Well-defined fractures were not identified in the sample. Concrete paste carbonation and alteration were restricted to the core top surface and did not extend appreciably into the concrete paste, as indicated by the Phenolphthalein Test to detect calcium hydroxide. The concrete appeared to be of good quality with little evidence of concrete paste alteration or internal distress. The hydrated concrete paste was light gray (N 7) in color, moderately hard, and slightly absorptive with occasional unhydrated cement clinker, and portland-cement hydration by-products appeared to be of normal distribution, and numerous entrained-air voids were present.

- d. *Core Sample No. T-5-1A.* This vertical core sample of bridge-deck pavement concrete submitted by the Mississippi DOT measured 2.9 in. in length by 4.0 in. in diameter. The concrete was composed of gap-graded, rounded quartzite and chert coarse aggregate that was 1/2-in. nominal diameter, variable in color; ranging from moderate yellow-brown (10 YR 5/4), grayish pink (5 R 8/2) to dark reddish brown (10 R 3/4-Munsell Color Classification). The fine aggregate was composed of angular-to-round, natural quartzose sand fine aggregate. The concrete was consolidated, although entrapped-air voids were common in the concrete paste matrix. The top surface of the core represented the bridge-deck pavement finished surface or free-face and was coated with white paint, was flat and somewhat roughened, with fine/coarse aggregate protruding from the surface. A closed, irregular-shaped crack, passing predominately around aggregate and through the concrete paste, narrowing with depth into the concrete, that penetrated the core top surface to a depth of 2.6 in., as measured from the core top (Figure J6), was identified as a shrinkage crack. Steel reinforcing bar was not identified in the core sample. The core bottom was formed by a rough, irregular fracture surface that was partially weathered and contained brown-black steel corrosion residue coating a reinforcing steel bar impression in the surface (Figure J7). Concrete paste carbonation and alteration were restricted to the core top and fracture surface and did not extend appreciably into the concrete paste, as indicated by the Phenolphthalein Test to detect calcium hydroxide. The hydrated concrete paste was medium light gray (N 7) in color, moderately hard and slightly absorptive, with occasional coarse (0.1 mm in diameter) unhydrated cement clinker. The cement hydration by-products such as calcium hydroxide, ettringite, and C-S-H appeared to be of normal distribution, and entrained-air voids were not abundant, indicating inadequate freezing-and-thawing protection.
- e. *Core Sample No. 4-2C.* This vertical core sample of bridge-deck pavement concrete submitted by the Mississippi DOT measured 5.95 in. in length by 3.95 in. in diameter. The concrete was composed of uniformly distributed, 1-in.-maximum diameter, siliceous coarse aggregate similar in composition and condition to the previously

described core sample (T-5-1A), and the aggregate appeared to be gap-graded. The fine aggregate was composed of angular-to-round, natural, quartzose sand. The concrete was poorly consolidated due to the presence of honey-combing, specifically at about 4.5 in. below the core top (Figure J8). The core top surface represented the former bridge-deck pavement finished surface or free-face and was roughened due to surface scaling and spalling, with popout remnants protruding from the surface (Figure J9). Steel reinforcement bar was not identified in the core sample. A closed, irregular crack passing around aggregate and through the concrete paste penetrated the core top surface to a depth of 1.1 in., as measured from the core top. The core bottom was formed by a rough, weathered, irregular fracture surface that passed through a honeycomb zone. Concrete paste carbonation and alteration was restricted to the core top and fracture surfaces and extended approximately 0.2 in. into the concrete surface, as indicated by the Phenolphthalein Test to detect calcium hydroxide. The hydrated concrete paste was medium light gray (N 7) to yellowish gray (5 Y 8/1) in color, was soft to moderately hard and absorptive, with occasional unhydrated cement clinker present. The cement hydration by-products, such as ettringite and C-S-H gel, appeared to be of normal distribution, although calcium hydroxide appeared to be elevated, indicative of an elevated water/cement ratio. X-ray diffraction analysis of selected paste concentrates indicated cement hydration by-products such as calcium hydroxide, ettringite, and C-S-H gel were present, and entrained-air voids were not common. See Table J2.

## Post-Injection Concrete Cores

- a. *Core Sample No. S35-25132, C-5A.* This vertical core sample of bridge-deck pavement concrete submitted by the Michigan DOT measured 6.35 in. in length by 3.70 in. in diameter and was composed of coarse and fine aggregate similar in composition to Core No. S35-25132, C-3. Fractures oriented subparallel to the core top were completely in-filled by the polymer injection material (Table J3).
- b. *Core Sample No. S35-25132, 5B.* This vertical core sample of bridge-deck pavement concrete submitted by the Michigan DOT measured 5.75 in. in length by 3.7 in. in diameter and was composed of coarse and fine aggregate similar in composition to Core No. S35-25132, C-3. Fractures oriented subparallel to the core top were completely in-filled by the polymer injection material (Table J3). The tensile test generated failure planes in the concrete with only minor polymer pullout in the attachment platten.
- c. *Core Sample No. S35-25132, 6B.* This vertical core sample of bridge-deck pavement concrete submitted by the Michigan DOT measured

approximately 6 in. in length by 4.0 in. in diameter and was composed of coarse and fine aggregate similar in composition to Core No. S35-25132, C-3. Fractures oriented subparallel to the core top were completely in-filled by the polymer injection material (Table J3). The tensile test generated failure planes predominantly in the concrete, with only 4 percent of the tensile failure surface passing through the pre-existing polymer-injected fracture plane.

- d. *Core Sample No. S05-09101: C-1A.* This vertical core sample of bridge-deck pavement concrete submitted by the Michigan DOT measured 6.7 in. in length by 3.7 in. in diameter and was composed of coarse and fine aggregate similar in composition to Core No. S35-25132, C-3. The polymer flood coat was of uniform distribution and well bonded to the concrete core top surface. The polymer flood-coat layer (a mixture of polymer binder and black, fine aggregate particles) measured approximately 0.02 in. thick (maximum), and the maximum polymer penetration depth measured 0.03 in. into the concrete surface (Table J4).
- e. *Core Sample No. S-3-IM.* This vertical core sample of bridge-deck pavement concrete submitted by the Mississippi DOT measured 2.2 in. in length by 4.0 in. in diameter and was composed of coarse and fine aggregate similar in composition to Core Nos. T-5-1A and 4-2C. Fractures oriented subparallel to the core top were completely in-filled by the polymer injection material, although polymer was absent in surface shrinkage cracks (Table J4). The tensile test generated failure planes predominantly in the concrete, with only 4 percent of the tensile failure surface passing through the pre-existing polymer-injected fracture plane.
- f. *Core Sample No. T-5-IM.* This vertical core sample of bridge-deck pavement concrete submitted by the Mississippi DOT measured 2.75 in. in length by 4.0 in. in diameter and was composed of coarse and fine aggregate similar in composition to Core Nos. T-5-1A and 4-2C. Fractures oriented subparallel to the core top were completely in-filled by the polymer injection material, although polymer was absent in surface shrinkage cracks (Table J4). The tensile test generated failure planes predominantly in the concrete, with only 8 percent of the tensile failure surface passing through the pre-existing polymer-injected fracture plane and injection port void.
- g. *Core Sample No. U-2-IM.* This vertical core sample of bridge-deck pavement concrete submitted by the Mississippi DOT measured 5.25 in. in length by 4.0 in. in diameter and was composed of coarse and fine aggregate similar in composition to Core Nos. T-5-1A and 4-2C. Fractures oriented subparallel to the core top were completely in-filled by the polymer injection material (Table J4). The tensile test

generated partial failure planes entirely in the concrete, with no failure surface passing through the pre-existing polymer-injected fracture.

## Category I Surface Treatment

- a. *Core Sample No. S05-09101: C-2A.* This vertical core sample of bridge-deck pavement concrete submitted by the Michigan DOT measured 6.1 in. in length by 3.7 in. in diameter and was composed of coarse and fine aggregate similar in composition to Core No. S35-25132, C-3, with coarse aggregate maximum diameter approximately 1-1/2 in. The core bottom was formed by a drill-induced mechanical fracture. Steel reinforcement (1/2 in. in diameter) was located 3.55 in. below the core top. The polymer flood-coat layer (a mixture of polymer binder and black, fine aggregate particles) was of uniform distribution and well bonded to the concrete core top surface. The flood-coat layer measured approximately 0.04 in. thick (maximum), with a maximum polymer penetration depth measuring 0.03 in. into the concrete surface (Table J5).
- b. *Core Sample No. S05-09101: C-6A.* This vertical core sample of bridge-deck pavement concrete submitted by the Michigan DOT measured 7.0 in. in length by 3.7 in. in diameter and was composed of coarse and fine aggregate similar in composition to Core No. S35-25132, C-3, with coarse aggregate maximum diameter approximately 2-1/4 in. The polymer flood-coat layer (a mixture of polymer binder and black, fine aggregate particles) was of uniform distribution and well bonded to the concrete core top surface. The flood-coat layer measured approximately 0.02 in. thick (maximum), with a maximum polymer penetration depth measuring 0.06 in. into the concrete surface (Table J5).
- c. *Core Sample No. S05-09101: C-7A.* This vertical core sample of bridge-deck pavement concrete submitted by the Michigan DOT measured 6.25 in. in length by 3.7 in. in diameter and was composed of coarse and fine aggregate similar in composition to Core No. S35-25132, C-3, with coarse aggregate maximum diameter approximately 1-1/2 in. The core bottom was formed by a drill-induced mechanical fracture. Steel reinforcement (5/8 in. in diameter) was located 2.6 in. below the core top, and 1-1/4-in.-diameter steel reinforcement was located 3.7 in. below the core top. The polymer flood-coat layer (a mixture of polymer binder and black, fine aggregate particles) was of uniform distribution and well bonded to the concrete core top surface. The flood-coat layer measured approximately 0.03 in. thick (maximum) with a maximum polymer penetration depth measuring 0.09 in. into the concrete surface (Table J5).
- d. *Core Sample No. S06-09101: C-1A.* This vertical core sample of bridge-deck pavement concrete submitted by the Michigan DOT measured

6.68 in. in length by 3.68 in. in diameter and was composed of coarse and fine aggregate similar in composition to Core No. S35-25132, C-3, with coarse aggregate maximum diameter approximately 1-1/2 in. The core bottom was formed by a drill-induced mechanical fracture. Steel reinforcement (1/2 in. in diameter) was located 4.6 in. below the core top. The polymer flood-coat layer (a mixture of polymer binder and black, fine aggregate particles) was of uniform distribution and well bonded to the concrete core top surface. The flood-coat layer measured approximately 0.03 in. thick (maximum), with maximum polymer penetration depth measuring 0.05 in. into the concrete surface (Table J5).

- e. *Core Sample No. S06-09101: C-3A.* This vertical core sample of bridge-deck pavement concrete submitted by the Michigan DOT measured 6.25 in. in length by 3.70 in. in diameter and was composed of coarse and fine aggregate similar in composition to Core No. S35-25132, C-3, with coarse aggregate maximum diameter approximately 1-3/4 in. The core bottom was formed by a drill-induced mechanical fracture. Steel reinforcement (1/2 in. in diameter) was located 4.3 in. below the core top. The polymer flood-coat layer (a mixture of polymer binder and black, fine aggregate particles) was of uniform distribution and well bonded to the concrete core top surface. The flood-coat layer measured approximately 0.02 in. thick (maximum), with a maximum polymer penetration depth measuring 0.02 in. into the concrete surface (Table J5).
- f. *Core Sample No. S06-09101, C-5A.* This vertical core sample of bridge-deck pavement concrete submitted by Michigan DOT measured 6.8 in. in length by 3.7 in. in diameter and was composed of coarse and fine aggregate similar in composition to Core No. S35-25132, C-3, with coarse aggregate maximum diameter approximately 1-1/4 in. Steel reinforcement (1/2 in. diameter) was located at 3.7 and 4.9 in. below the core top. The core bottom was formed by a drill-induced mechanical fracture. The polymer flood-coat layer (a mixture of polymer binder and black, fine aggregate particles) was of uniform distribution and well bonded to the concrete core top surface. The flood coat layer measured approximately 0.01 to 0.02 in. thick (maximum) with maximum polymer penetration depth measured 0.02 in. into the concrete surface (Table J5).
- g. *Core Sample No. S06-09101, C-6A.* This vertical core sample of bridge-deck pavement concrete submitted by the Michigan DOT measured 6.0 in. in length by 3.68 in. in diameter and was composed of coarse and fine aggregate similar in composition to Core No. S35-25132, C-3, with coarse aggregate maximum diameter approximately 1-1/2 in. The core bottom was formed by a drill-induced mechanical fracture. The polymer flood-coat layer (a mixture of polymer binder and black fine aggregate particles) was of uniform distribution and well bonded to the

concrete core top surface. The flood-coat layer measured approximately 0.01 to 0.02 in. thick (maximum), with maximum polymer penetration depth measuring 0.02 in. into the concrete surface (Table J5).

- h. Core Sample No. S-1-TRB-SH.* This vertical core sample of bridge deck-pavement concrete submitted by the Mississippi DOT measured 3.95 in. in length by 3.95 in. in diameter. The polymer flood-coat layer (a mixture of polymer binder and black, fine aggregate particles) was of uniform distribution and well bonded to the concrete core top surface. The flood-coat layer measured approximately 0.06 in. thick (maximum), with a maximum polymer penetration depth measuring 0.03 in. into the concrete surface (Table J5).
- i. Core Sample No. S-4-TRB-SH.* This vertical core sample of bridge-deck pavement concrete submitted by the Mississippi DOT measured 3.95 in. in length by 4.0 in. in diameter. The polymer flood-coat layer (a mixture of polymer binder and black, fine aggregate particles) was of uniform distribution and well bonded to the concrete core top surface. The flood-coat layer measured approximately 0.06 in. thick (maximum), with a maximum polymer penetration depth measuring 0.14 in. into the concrete surface (Table J5).
- j. Core Sample No. T-1-TRB-SH.* This vertical core sample of bridge-deck pavement concrete submitted by the Mississippi DOT measured 1.2 in. in length by 4.0 in. in diameter. The polymer flood-coat layer (a mixture of polymer binder and black fine aggregate particles) was of uniform distribution and well bonded to the concrete core top surface. The flood-coat layer measured approximately 0.01 to 0.02 in. thick (maximum), with a maximum polymer penetration depth measuring 0.12 in. (Table J5) into the concrete surface.
- k. Core Sample No. T-2-TRB-SH.* This vertical core sample of bridge-deck pavement concrete submitted by the Mississippi DOT measured 3.9 in. in length by 4.0 in. in diameter. The polymer flood-coat layer (a mixture of polymer binder and black, fine aggregate particles) was of uniform distribution and well bonded to the concrete core top surface. The flood-coat layer measured approximately 0.02 in. thick (maximum), with a maximum polymer penetration depth measuring 0.24 in. into the concrete surface (Table J5).
- l. Core Sample No. U-2-TRB-SH.* This vertical core sample of bridge-deck pavement concrete submitted by the Mississippi DOT measured 3.65 in. in length by 4.0 in. in diameter. The polymer flood-coat layer (a mixture of polymer binder and black, fine aggregate particles) was of uniform distribution and well bonded to the concrete core top surface. The flood-coat layer measured approximately 0.02 in. thick (maximum), with a maximum polymer penetration depth measuring 0.07 in. into the concrete surface (Table J5).

- m. Core Sample No. U-4-TRB-SH.* This vertical core sample of bridge-deck pavement concrete submitted by the Mississippi DOT measured 3.25 in. in length by 4.0 in. in diameter. The polymer flood-coat layer (a mixture of polymer binder and black, fine aggregate particles) was of uniform distribution and well bonded to the concrete core top surface. The flood-coat layer measured approximately 0.02 in. thick (maximum), with a maximum polymer penetration depth measuring 0.03 in. into the concrete surface (Table J5).

## Category II Surface Treatment

- a. Core Sample No. H-1-TRB/FC.* This vertical core sample of bridge-deck pavement concrete submitted by the Mississippi DOT measured 3.15 in. in length by 4.0 in. in diameter. The polymer/aggregate overlay (a mixture of polymer binder and black, fine aggregate particles) was of uniform distribution and well bonded to the concrete core top surface. The overlay measured 0.17 in. (average) in thickness with a maximum polymer penetration depth measuring 0.07 in. into the concrete surface (Table J6).
- b. Core Sample No. H-2-TRB/FC.* This vertical core sample of bridge-deck pavement concrete submitted by the Mississippi DOT measured 4.2 in. in length by 4.0 in. in diameter. The polymer/aggregate overlay (a mixture of polymer binder and black, fine aggregate particles) was of uniform distribution and well bonded to the concrete core top surface. The overlay measured 0.26 in. (average) in thickness, with a maximum polymer penetration depth measuring 0.01 to 0.02 in. into the concrete surface (Table J6).
- c. Core Sample No. R-2-TRB/FC.* This vertical core sample of bridge-deck pavement concrete submitted by the Mississippi DOT measured 3.95 in. in length by 4.0 in. in diameter. The polymer/aggregate overlay (a mixture of polymer binder and black, fine aggregate particles) was of uniform distribution and well bonded to the concrete core top surface. The overlay measured 0.22 in. (average) in thickness, with a maximum polymer penetration depth measuring 0.02 in. into the concrete surface (Table J6).
- d. Core Sample No. R-3-TRB/FC.* This vertical core sample of bridge-deck pavement concrete submitted by the Mississippi DOT measured 4.40 in. in length by 4.0 in. in diameter. The polymer/aggregate overlay (a mixture of polymer binder and black, fine aggregate particles) was of uniform distribution and well bonded to the concrete core top surface. The overlay measured 0.25 in. (average) in thickness, with a maximum polymer penetration depth measuring 0.02 in. into the concrete surface (Table J6).

- e. *Core Sample No. S-1-TRB/FC.* This vertical core sample of bridge-deck pavement concrete submitted by the Mississippi DOT measured 3.35 in. in length by 4.0 in. in diameter. The polymer/aggregate overlay (a mixture of polymer binder and black fine aggregate particles) was of uniform distribution and well bonded to the concrete core top surface. The overlay measured 0.20 in. (average) in thickness, with a maximum polymer penetration depth measuring 0.06 in. into the concrete surface (Table J6).
- f. *Core Sample No. S-2-TRB/FC.* This vertical core sample of bridge-deck pavement concrete submitted by the Mississippi DOT measured 3.5 in. in length by 4.0 in. in diameter. The polymer/aggregate overlay (a mixture of polymer binder and black, fine aggregate particles) was of uniform distribution and well bonded to the concrete core top surface. The overlay measured 0.15 in. (average) in thickness, with a maximum polymer penetration depth measuring 0.02 in. into the concrete surface (Table J6).
- g. *Core Sample No. T-2-TRB/FC.* This vertical core sample of bridge-deck pavement concrete submitted by the Mississippi DOT measured 3.4 in. in length by 4.0 in. in diameter. The polymer/aggregate overlay (a mixture of polymer binder and black, fine aggregate particles) was of uniform distribution and well bonded to the concrete core top surface. The overlay measured 0.26 in. (average) in thickness with a maximum polymer penetration depth measuring 0.06 in. into the concrete surface (Table J6).
- h. *Core Sample No. T-4-TRB/FC.* This vertical core sample of bridge-deck pavement concrete submitted by the Mississippi DOT measured 3.70 in. in length by 4.0 in. in diameter. The polymer/aggregate overlay (a mixture of polymer binder and black, fine aggregate particles) was of uniform distribution and well bonded to the concrete core top surface. The overlay measured 0.25 in. (average) in thickness, with a maximum polymer penetration depth measuring 0.02 in. into the concrete surface (Table J6).
- i. *Core Sample No. U-3-TRB/FC.* This vertical core sample of bridge-deck pavement concrete submitted by the Mississippi DOT measured 2.85 in. in length by 4.0 in. in diameter. The polymer/aggregate overlay (a mixture of polymer binder and black, fine aggregate particles) was of uniform distribution and well bonded to the concrete core top surface. The overlay measured 0.40 in. (average) in thickness, with a maximum polymer penetration depth measuring 0.07 in. into the concrete surface (Table J6).
- j. *Core Sample No. U-4-TRB/FC.* This vertical core sample of bridge-deck pavement concrete submitted by the Mississippi DOT measured 2.65 in. in length by 4.0 in. in diameter. The polymer/aggregate overlay (a

mixture of polymer binder and black, fine aggregate particles) was of uniform distribution and well bonded to the concrete core top surface. The overlay measured 0.33 in. (average) in thickness, with a maximum polymer penetration depth measuring 0.15 in. into the concrete surface.

## Conclusions and Recommendations

Petrographic examination of the subject concrete core samples of bridge-deck pavement indicates the concrete represented in the core samples is variable in extent of deterioration. The mechanism that has generated the deterioration observed in the Mississippi DOT cores appears to be due to several processes, predominantly fracturing and microcracking of the concrete by shrinkage cracking, freezing-and-thawing action, and reinforcing-steel corrosion based on fracture morphology and the presence of iron precipitate (steel reinforcing-bar corrosion by-product) coating the various core bottom fracture surfaces. Microcracks and vertical shrinkage cracks provide pathways for moisture, chemicals (de-icing salts), and gases (carbon dioxide) to more easily penetrate the concrete cover to the reinforcing steel, destroying the protective passive oxide film layer formed on the steel surfaces in the high-alkalinity environment of cured portland-cement concrete, thus allowing corrosion to initiate. The corrosion process generates secondary iron precipitates (e.g. limonite, lepidocrocite, and goethite) that have the capacity for volume increase during formation that further internally distresses the concrete, generating additional microcracking and continued concrete expansion. The air-void system for the Mississippi cores does not appear adequate to protect the concrete against freezing-and-thawing action, and secondary deposits have in-filled air-voids, reducing the effectiveness of the air-void system in providing freezing-and-thawing protection.

The presence of tetracalcium aluminate dichloride identified in concrete paste concentrates of Michigan Core No. S05-09101, C-1 (Figure J4) suggests chloride attack may have accelerated the reinforcing-steel corrosion process and to a minor degree may have aided alkali-silica reaction in increasing internal distress in the concrete. Other deterioration processes, such as sulfate attack and other forms of long-term leaching or chemical attack, were not identified in the bridge-deck samples examined.

To reduce or arrest concrete deterioration as identified in the subject core samples, it is critical that moisture ingress into the concrete be controlled. Spall and fracture areas should be repaired as soon as identified, and surfaces should be treated with sealants/bonding agents to limit moisture, chemical, and gas ingress into the concrete to improve the resistance of the concrete surfaces to deterioration. The previously identified deterioration processes require moisture to initiate or promote deterioration and pathways for the moisture to travel to increase the extent of the deterioration.

The efficacy of the polymer treatment (flood coating and injection) on the delaminated, deteriorated bridge-deck concrete wearing surfaces was found to be successful in rebonding fracture surfaces and maximizing fracture impregnation in core samples from both Michigan and Mississippi DOTs. The polymer injection of existing fractures was uniform, resulting in a high percentage of fracture plane bonds, although the depth of penetration, as measured from the top of core, was limited to approximately 2 in. The bond strength along the fracture plane surfaces appears to be equal to or greater than the tensile strength of the surrounding concrete, as testing of selected specimens produced failure planes passing predominantly through the concrete and not along the polymer-injected fracture planes. Occasional fracture surfaces (Mississippi core samples) injected with polymer material did not develop acceptable bond characteristics due primarily to accumulated trapped air along portions of the fracture surfaces. An important factor affecting the degree of polymer penetration and the quality of the resulting polymer bond appears to be the degree of communication between the fracture surfaces. Mississippi cores showed inconsistent communication between the vertically oriented shrinkage cracks and polymer-injected horizontal cracks, prohibiting polymer transmission. By injection followed by flood coating, surface shrinkage cracks can be filled without requiring communication with cracks intercepted only by the injection ports. Other factors affecting polymer injection are depth of port placement, amount of debris and moisture coating the fracture surfaces, distance from the injection ports, and viscosity of the injected polymer medium. Decreasing viscosity and distance between injection ports while increasing depth of injection ports may intercept more isolated fracture systems, although the current port-spacing scheme appears to provide effective fracture surface impregnation.

**Table J1**  
**Michigan DOT Core Petrographic Analysis Summary**

1. Little evidence of concrete distress in the form of cracking, although surface cracks were identified in Core No. S05-09101, C-1.
2. Top surfaces contain only minor evidence of paste matrix loss and very minor surface carbonation.
3. Consolidation is good with few incidental entrapped air voids.
4. Concrete paste water/cement ratio low to moderate.
5. Coarse and fine aggregates contain no evidence of internal distress or reaction.
6. Concrete paste appears to contain adequate air-entrainment.
7. Microcracks identified in concrete paste matrix associated with minor alkali-silica gel formation.
8. No evidence of sulfate attack, chemical leaching, freezing-and-thawing damage, or other deterioration process present, although chloroaluminate was identified, suggesting possible chloride attack.

**Table J2**  
**Polymer Mississippi DOT Core Petrographic Analysis Summary**

1. Vertical fractures (shrinkage cracks) penetrate nearly the entire core length and predominantly pass around coarse and fine aggregate (Core Nos. T-C-1, T-4-1A, T-5-1A).
2. Scaled surface contains carbonated, absorptive mortar layer (Core No. 4-2C).
3. Incomplete consolidation with the presence of large incidental air voids (Core No. 4-2C).
4. Elevated concrete paste water/cement ratio (Core No. 4-2C).
5. Deleterious, absorptive aggregate producing surface popouts and distress on surface only (Core No. 4-2C).
6. Evidence of reinforcing-steel corrosion identified in the core samples.
7. Concrete paste is not properly air-entrained.
8. Evidence of alkali-silica reaction (ASR), sulfate attack, chemical leaching, or other deterioration process is absent.

**Table J3**  
**Polymer-Injected and Non-Injected Fracture Length and Ratio**  
**Determination for Spillway Bridge Deck Concrete<sup>1</sup>**

Parameter	Sample No.		
	S35-25132-C-5A	S35-25132-C5B	S35-25132-C-6B
Minimum depth <sup>2</sup> of polymer penetration	0.48 in.	0.80 in.	0.57 in.
Maximum depth <sup>2</sup> of polymer penetration	2.08 in.	1.98 in.	2.00 in.
Maximum depth <sup>1</sup> of unfilled fractures	None	None	None
Total length of injected fractures	18.22 in.	20.22 in.	22.94 in.
Total length of unfilled fractures	0.0	0.0	0.0
Ratio of polymer-filled fractures to unfilled fractures	N/A	N/A	N/A
Tensile strength	191 psi	191 psi	163 psi
Tensile test failure plane	All in concrete	All in concrete	4 percent in polymer injection plane

<sup>1</sup> Michigan DOT core post-injection analysis.  
<sup>2</sup> Depth as measured from the core top, parallel to the core axis.

**Table J4**  
**Polymer-Injected and Non-Injected Fracture Length and Ratio**  
**Determination for Spillway Brige-Deck Concrete, Mississippi DOT**  
**Core Post-Injection Analysis Summary**

Parameter	Sample No.		
	U-2-IM	S-3-Im	T-5-IM
Minimum depth <sup>1</sup> of polymer penetration	0.25 in.	0.84 in.	0.23 in.
Maximum depth <sup>1</sup> of polymer penetration	0.95 in.	1.31 in.	2.02 in.
Maximum depth <sup>1</sup> of unfilled fractures	None	101 in.	1.02 in.
Total length of injected fractures	13.38 in.	14.25 in.	21.28 in.
Total length of unfilled fractures	0.0	2.25 in.	3.22 in.
Ratio of filled fractures to unfilled fractures	N/A	6.33	6.61
Tensile strength	36 psi	159 psi	80 psi
Tensile test failure plane	All in concrete matrix	4 percent of failure plane passed through polymer injection plane	8 percent of failure plane passed through polymer injections plane

<sup>1</sup> Depth as measured from the core top, parallel to the core axis.

<b>Table J5 Category I Surface Treatment</b>		
<b>Core Sample No.</b>	<b>Polymer Flood-Coat Layer Thickness, in.</b>	<b>Polymer Maximum Penetration Depth, in.<sup>1</sup></b>
<b>Michigan DOT Core Samples</b>		
S05-09101, C-1A.	0.02	0.03
S05-09101, C-2A.	0.04	0.03
S05-09101, C-6A.	0.02	0.06
S05-09101, C-7A.	0.03	0.09
S06-09101, C-1A.	0.03	0.05
S06-09101, C-3A.	0.02	0.02
S06-09101, C-5A.	0.02	0.02
S06-09101, C-6A.	0.02	0.02
<b>Mississippi DOT Core Samples</b>		
S-1-TRB-SH.	0.06	0.03
S-4-TRB-SH.	0.06	0.14
T-1-TRB-SH.	0.02	0.12
T-2-TRB-SH.	0.02	0.24
U-2-TRB-SH.	0.02	0.07
U-4-TRB-SH.	0.02	0.03
<sup>1</sup> Depth as measured from the core top, parallel to the core axis.		

<b>Table J6 Category II Surface Treatment, Mississippi DOT Core Samples</b>		
<b>Core Sample No.</b>	<b>Polymer Overlay Layer Thickness, in.</b>	<b>Polymer Maximum Penetration Depth, in.<sup>1</sup></b>
H-1-TRB/FC	0.17	0.07
H-2-TRB/FC.	0.26	0.02
R-2-TRB/FC.	0.22	0.02
R-3-TRB/FC.	0.25	0.02
S-1-TRB/FC.	0.20	0.06
S-2-TRB/FC.	0.15	0.02
T-2-TRB/FC.	0.26	0.06
T-4-TRB/FC.	0.25	0.02
U-3-TRB/FC.	0.40	0.07
U-4-TRB/FC.	0.33	0.15
<sup>1</sup> Depth as measured from the core top, parallel to the core axis.		



Figure J1. Core Sample No. S05-09101-C-1. Profile view of 4-in.-diam bridge deck core showing overall size, condition, and presence of steel reinforcement (two circular objects imbedded in the concrete)

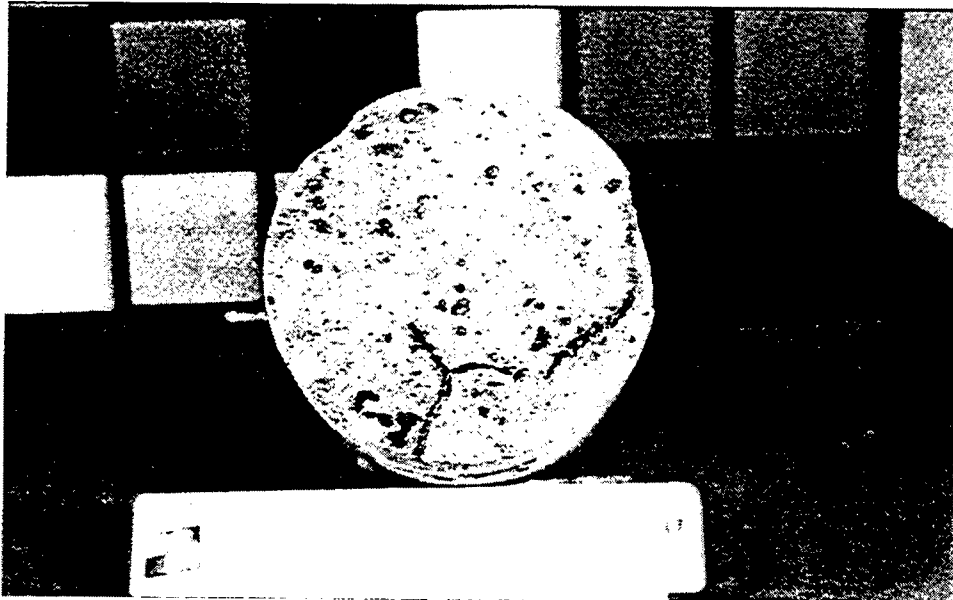

Figure J2. Core Sample No. S05-09101-C-1. End view of 4-in.-diam concrete bridge deck core showing condition of core top and presence of fine cracks (Black ink lines) in the surface

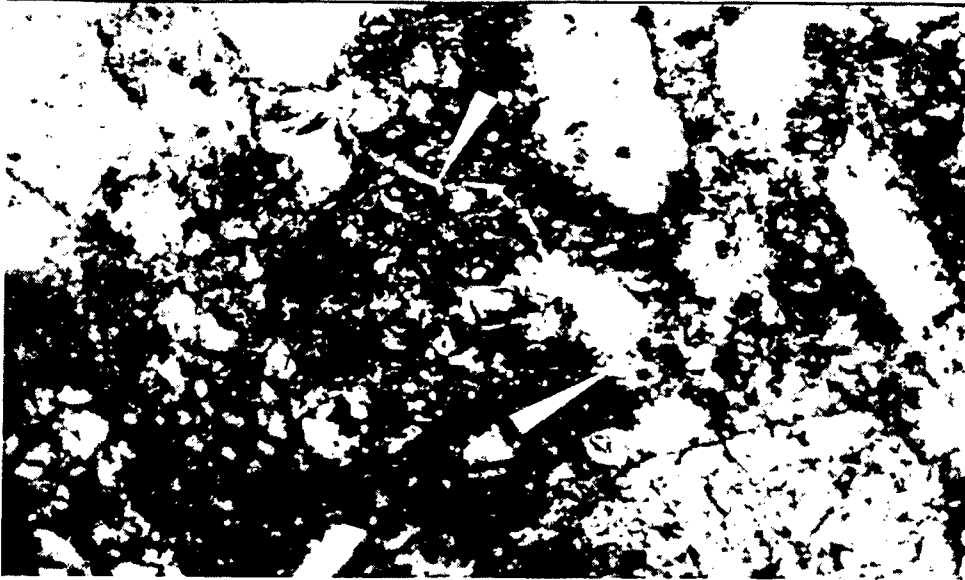

Figure J3. CPAR: Core Sample No. S05-09101-C-1. Thin section photomicrograph detailing microcracks (arrows) in the hydrated cement paste. Plane polarized light, 190 × Mag

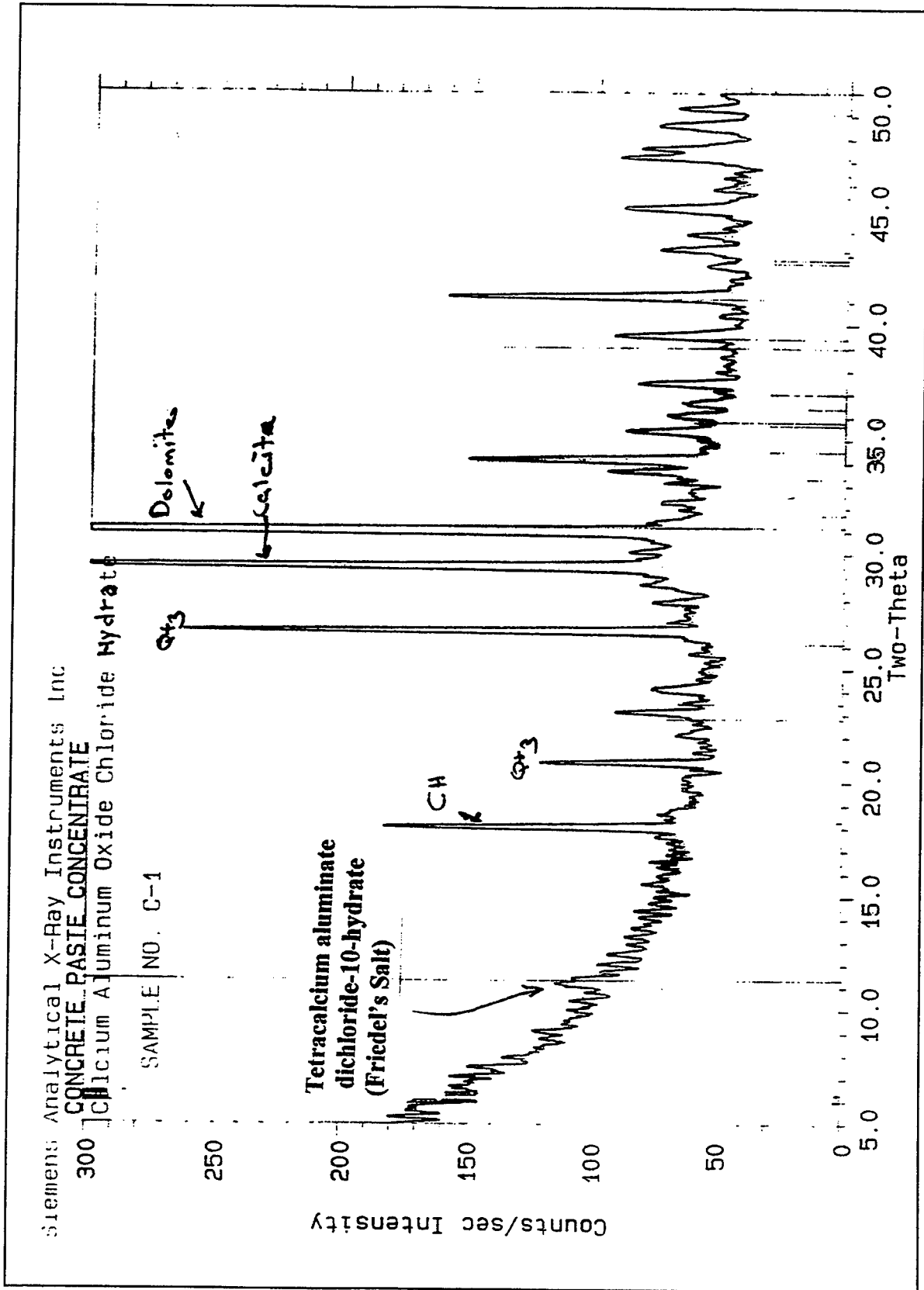

Figure J4. Diffraction diagram

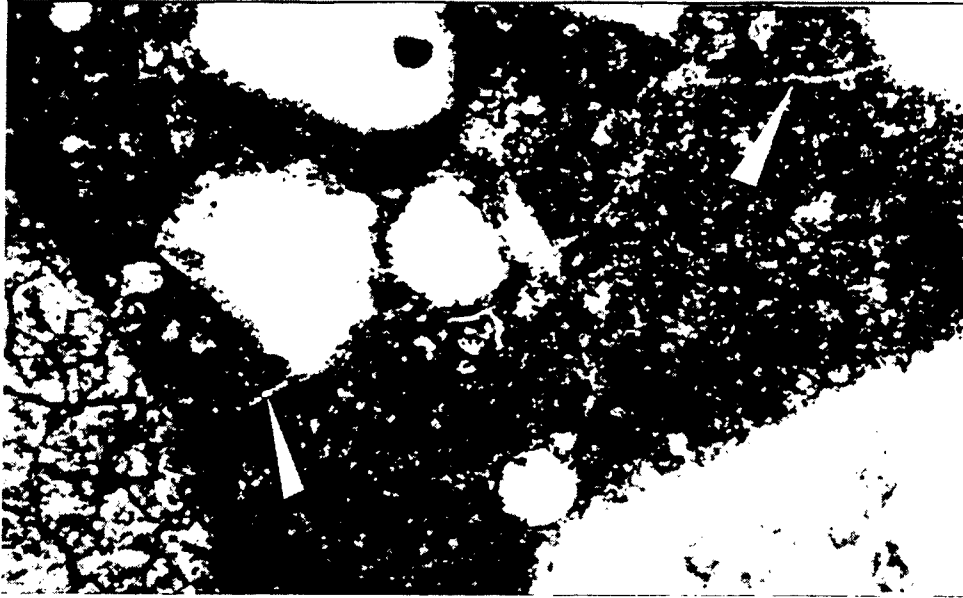

Figure J5. CPAR: Core Sample No. S35-25132, C-3. Thin section photomicrograph detailing microcracks (arrows) in the hydrated cement paste. Plane polarized light, 190 × Mag



Figure J6. Core Sample No T-5-1A. Enlarged view of photograph detailing morphology of the crack that penetrated from the core top surface (left side of photograph)

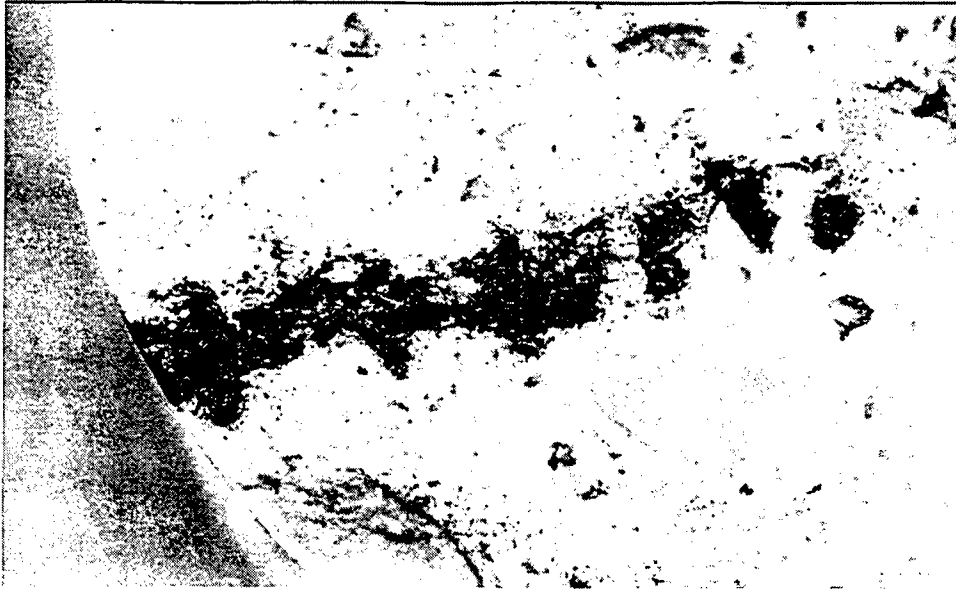

Figure J7. Core Sample No. T-5-1A. View of core bottom surface showing steel reinforcing-bar impression coated with steel corrosion by-product

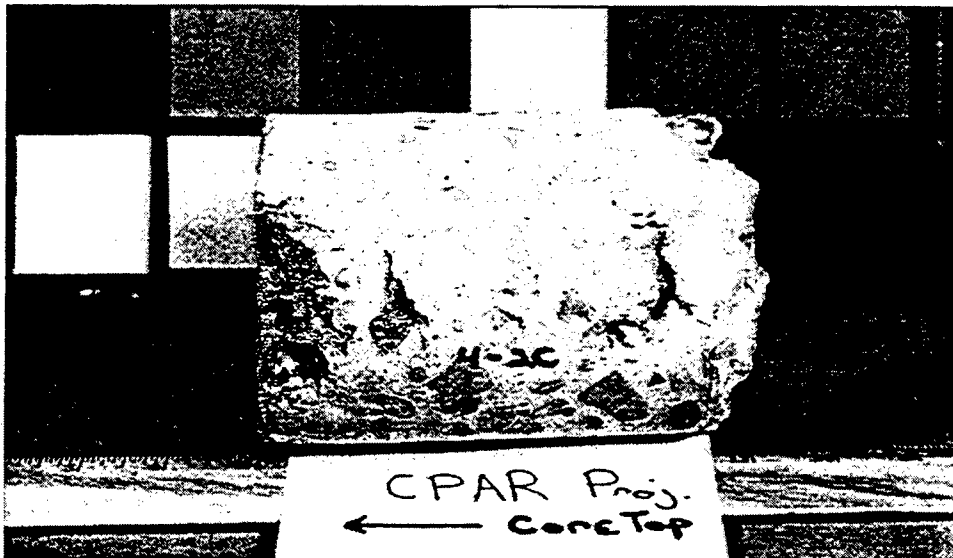

Figure J8. Core Sample No. 4-2C. Profile view of 4-in.-diam concrete bridge deck core showing overall size, condition, and orientation of the core top. Note numerous voids due to incomplete consolidation

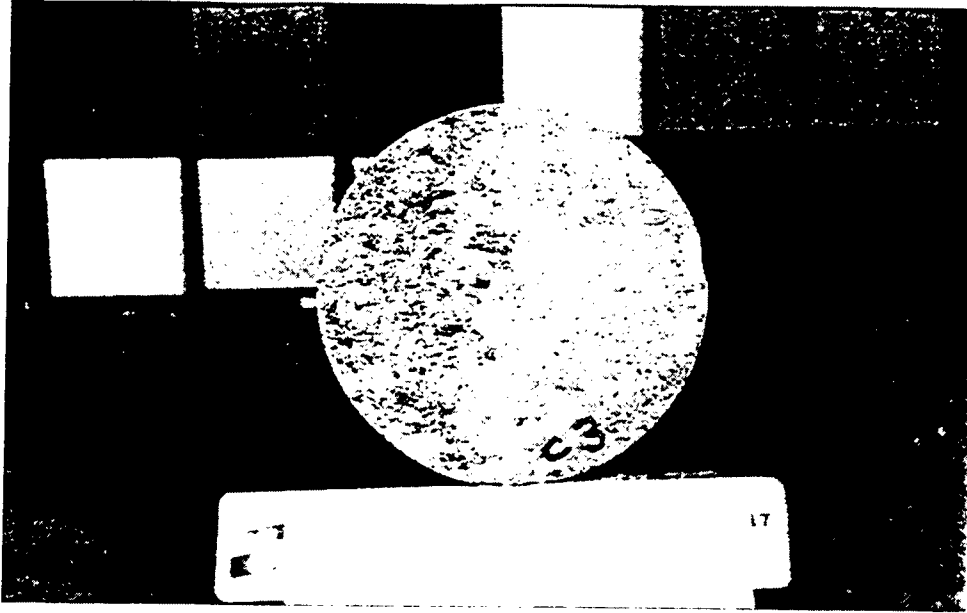

Figure J9. Core Sample No. 4-2C. End view of 4-in.-diam concrete bridge deck core showing roughened, spalled core top with aggregate pop-out voids in the surface

# REPORT DOCUMENTATION PAGE

Form Approved  
OMB No. 0704-0188

Public reporting burden for this collection of information is estimated to average 1 hour per response, including the time for reviewing instructions, searching existing data sources, gathering and maintaining the data needed, and completing and reviewing the collection of information. Send comments regarding this burden estimate or any other aspect of this collection of information, including suggestions for reducing this burden, to Washington Headquarters Services, Directorate for Information Operations and Reports, 1215 Jefferson Davis Highway, Suite 1204, Arlington, VA 22202-4302, and to the Office of Management and Budget, Paperwork Reduction Project (0704-0188), Washington, DC 20503.

<b>1. AGENCY USE ONLY (Leave blank)</b>		<b>2. REPORT DATE</b> September 1998	<b>3. REPORT TYPE AND DATES COVERED</b> Final report		
<b>4. TITLE AND SUBTITLE</b> Technologies for Improving the Evaluation and Repair of Concrete Bridge Decks: Ultrasonic Pulse Echo and Polymer Injection			<b>5. FUNDING NUMBERS</b>		
<b>6. AUTHOR(S)</b> A. Michel Alexander, Richard W. Haskins, Robert Cook, Mantu Baishya, Michael Kelly					
<b>7. PERFORMING ORGANIZATION NAME(S) AND ADDRESS(ES)</b> U.S. Army Engineer Waterways Experiment Station, 3909 Halls Ferry Road, Vicksburg, MS 39180-6199; University of Nebraska Center for Infrastructure Research, 60th and Dodge Street, Omaha, NE 68182-0461			<b>8. PERFORMING ORGANIZATION REPORT NUMBER</b> Technical Report CPAR-SL-98-1		
<b>9. SPONSORING/MONITORING AGENCY NAME(S) AND ADDRESS(ES)</b> U.S. Army Corps of Engineers Washington, DC 20314-1000			<b>10. SPONSORING/MONITORING AGENCY REPORT NUMBER</b>		
<b>11. SUPPLEMENTARY NOTES</b>  Available from National Technical Information Service, 5285 Port Royal Road, Springfield, VA 22161.					
<b>12a. DISTRIBUTION/AVAILABILITY STATEMENT</b>  Approved for public release; distribution is unlimited.			<b>12b. DISTRIBUTION CODE</b>		
<b>13. ABSTRACT (Maximum 200 words)</b> <p>A significant number of concrete bridge decks, both public- and nonpublic use, in the United States are subjected to a variety of detrimental environmental conditions. Many of the decks are in northern regions and are subject to cold weather; some of these are subjected to further degradation from the applications of deicing salts. The current major distress noted is the occurrence of shallow delaminations resulting in horizontal voids below the surface of the decks. It appears the majority of the delaminations are caused by freezing and thawing action, by chloride attack that corrodes the reinforcement, and by alkali-silica reaction. All three attack mechanisms require the presence of moisture. Efforts to design and place a dense, impermeable concrete are hindered at times due to the porous nature of concrete. As the concrete ages, a micro-system of tension cracks and other surface imperfections can develop, exposing the matrix to water and chloride infiltration. Water infiltration alone can lead to accelerated alkali-silica reaction and steel-reinforcement corrosion. Surface spalling not only reduces ride quality, but it leads to more serious problems including structural deterioration and failure.</p> <p>Many concrete sealers and penetrants on the market are designed to protect concrete by improving and enhancing its physical properties. Surface sealers such as silane, silicones, and siloxanes have been developed to prevent the infiltration of moisture and chlorides. Penetrants such as high molecular weight methacrylate (HMWM) and epoxies have been developed to penetrate and fill cracks and porous areas in the concrete, sealing it against the infiltration of air, water, and chloride.</p> <p style="text-align: right;">(Continued)</p>					
<b>14. SUBJECT TERMS</b> Bridge Concrete decks			<b>15. NUMBER OF PAGES</b> 280		
			<b>16. PRICE CODE</b>		
<b>17. SECURITY CLASSIFICATION OF REPORT</b> UNCLASSIFIED			<b>18. SECURITY CLASSIFICATION OF THIS PAGE</b> UNCLASSIFIED	<b>19. SECURITY CLASSIFICATION OF ABSTRACT</b>	<b>20. LIMITATION OF ABSTRACT</b>

### 13. (Concluded).

Once the concrete is effectively sealed, both the progression of alkali-silica reaction and the corrosion of the reinforcing steel are arrested. These materials are also designed to bond to the concrete and thus to the structural integrity of the concrete. Once the delamination voids are filled, the structural integrity of the pavement is regained without the cost and downtime of an overlay.

A case study is presented to determine the effectiveness of low-pressure injection of HMWM and epoxy material into delamination voids as a repair process for bridge decks. Test results, together with other physical property testing and modeling, are presented. Also included are suggested procedures, conclusions, and future test programs.

Currently, the only standard method of detecting delaminations in concrete bridge decks is the chain drag (ASTM Standard D 4580), "Standard Practice for Measuring Delaminations in Concrete Bridge Decks by Sounding"). As this method depends on someone having an "ear" for hearing the discriminating sound from a delamination, it is subjective. An objective method was needed to evaluate delaminations in bridge decks. The U.S. Army Engineer Waterways Experiment Station (WES) made significant advancements in the development of a new high-frequency, high-resolution, ultrasonic pulse echo (UPE) system for evaluating delaminations in concrete bridge decks.

Improvement of various functions was accomplished by the following means:

The signal quality was improved by the design of new transducers. The face of the transducers was angled to better direct the transmitted and received energy. Transducer materials were matched in their acoustic impedance to permit better efficiency of transmission and reception. An improved type of lead metaniobate was used as the piezoelectric material.

The speed of data acquisition was improved by the development of the rolling pond and a digital oscilloscope. The transducers were immersed in a thin layer of water kept in place by the rolling pond. The rolling pond consists of two large drums covered with a soft rubber and belt-driven pulleys which were covered in a rubber material. As the rolling pond moved along the deck, it provided a continuous rubber seal against the concrete surface and prevented the water from leaking from the protected space. The speed of data acquisition was improved by approximately 700X.

The identification of signals was improved by fabricating a store of physical models and developing a ray-based software model. Numerous concrete models were fabricated with varying thicknesses and with various simulated flaws and defects. These models were used in conjunction with the ray-based software model to identify multiple reflections, p-waves, shear waves, and surface waves.

The reduction of material noise (scattering from aggregate) was improved by a spectrum-processing algorithm. The presentation of results was improved by commercial software sold by MATLAB, Inc. Previously only one signal could be presented for analysis. MATLAB permitted about 200 signals to be observed in a B-scan presentation which improved the interpretation of results.

Progress was made toward the computer interpretation of signals with artificial neural networks (ANNs). Signal recognition is an important application of ANNs.

Progress was made on operator guidance on measurement procedure using an Expert System.

The system was named SUPERSCANNER, the acronym for Scanned Ultrasonic Pulse-Echo Results by Site-Characterization of Concrete Using Artificial Neural Networks and Expert Reasoning, although time constraints did not permit the ANN and Expert systems to be implemented. The new system demonstrates its potential for commercialization and competition with or replacement of the chain drag in the future. The WES prototype field system is available for performing evaluation services for various organizations.