



**US Army Corps
of Engineers**
Waterways Experiment
Station

Model Study of St. Stephen Powerhouse Fish Passage Facilities, Cooper River Rediversion Project, South Carolina

by *John E. Hite, Jr., Thomas E. Murphy, Jr.*

19981007 025

DTIC QUALITY INSPECTED 1

Approved For Public Release; Distribution Is Unlimited

Prepared for U.S. Army Engineer District, Charleston

DTIC QUALITY INSPECTED 1

The contents of this report are not to be used for advertising, publication, or promotional purposes. Citation of trade names does not constitute an official endorsement or approval of the use of such commercial products.

The findings of this report are not to be construed as an official Department of the Army position, unless so designated by other authorized documents.



PRINTED ON RECYCLED PAPER



**US Army Corps
of Engineers**
Waterways Experiment
Station

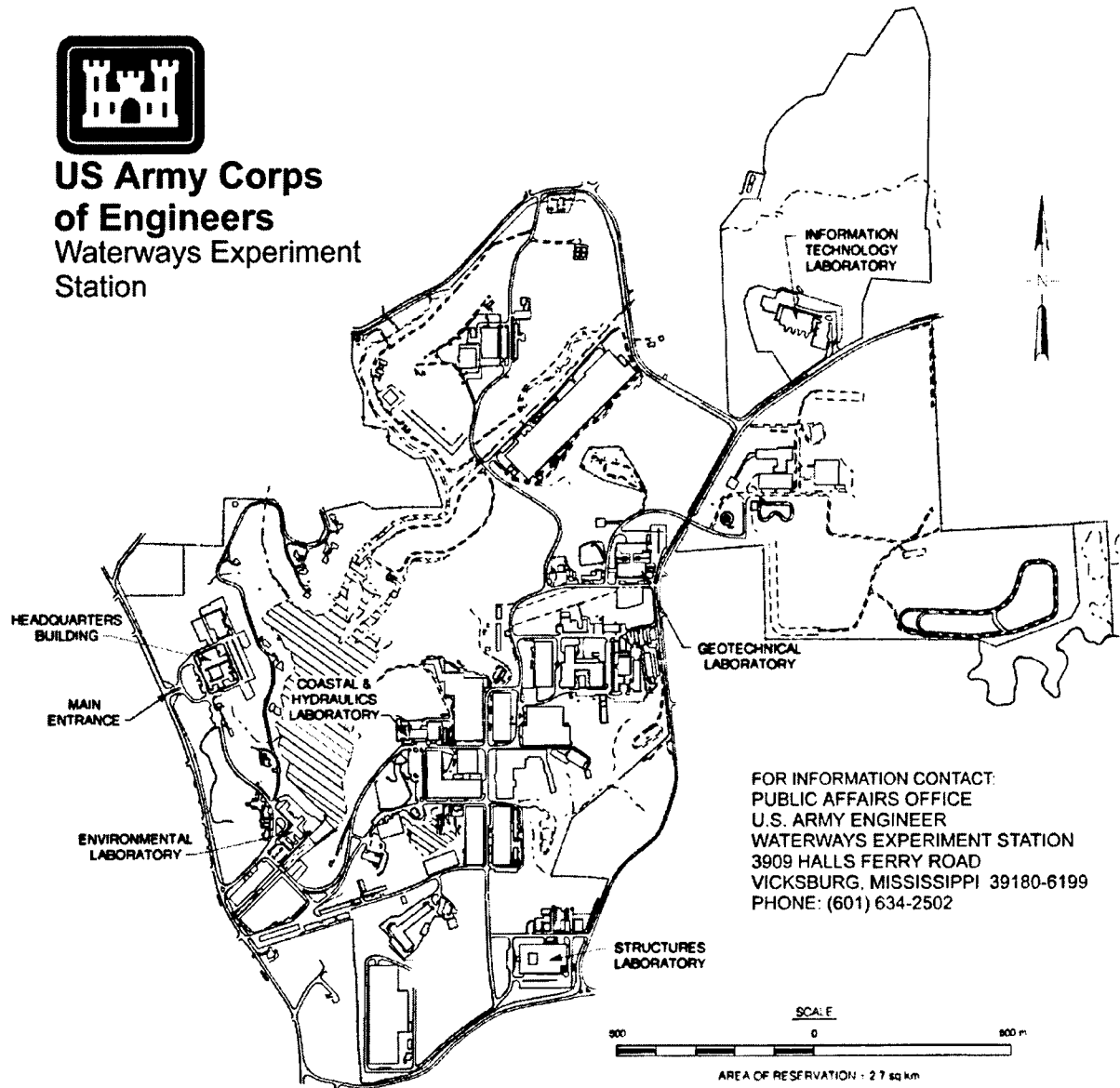

Waterways Experiment Station Cataloging-in-Publication Data

Hite, John E.

Model study of St. Stephen Powerhouse Fish Passage Facilities, Cooper River Rediversion Project, South Carolina / by John E. Hite, Jr., Thomas E. Murphy, Jr. ; prepared for U.S. Army Engineer District, Charleston.

93 p. : ill. ; 28 cm. — (Technical report ; CHL-98-27)

Includes bibliographic references.

1. Fishways — South Carolina. 2. Hydroelectric power plants — South Carolina. 3. Hydraulic models. I. Murphy, Thomas E. II. United States. Army. Corps of Engineers. Charleston District. III. U.S. Army Engineer Waterways Experiment Station. IV. Coastal and Hydraulics Laboratory (U.S. Army Engineer Waterways Experiment Station) V. Title. VI. Series: Technical report (U.S. Army Engineer Waterways Experiment Station) ; CHL-98-27.

TA7 W34 no.CHL-98-27

Contents

Preface	v
Conversion Factors, Non-SI to SI Units of Measurement	vii
1—Introduction	1
Background	1
Purpose and Scope of Model Investigations	3
2—The Models	5
Description	5
1:25-scale model	5
1:5-scale two-conduit model	5
1:5-scale three-conduit model	10
Model Appurtenances	14
Scale Relations	14
3—Experimental Results	16
1:25-Scale Type 1 Design AAF System	16
Type 1 riprap design	16
Water-surface elevations	16
Flow distribution in fish channel	17
1:25-Scale Type 2 Design AAF System	18
Type 2 floor grate	18
Type 2 ported channel design	19
Type 3 floor grate	19
Type 4 floor grate	19
Type 2 riprap design	20
Summary of Types 1 and 2 Design AAF Systems	20
1:5-Scale Type 3 Design AAF System	21
Type 2 design fish flume	21
Type 3 design fish flume	22
Type 4 design fish flume	22
Type 5 design fish flume	22
Type 6 design fish flume	22
Type 7 design fish flume	23
Type 8 design fish flume	23
Type 9 design fish flume	23

1:5-Scale Type 4 Design AAF System	24
Type 2 dewatering basin	25
Type 1 design hood	26
Type 3 design stilling basin	26
4—Summary, Conclusions, and Recommendations	31
Summary	31
Conclusions and Recommendations	32
Tables 1-19	
Photos 1-5	
Plates 1-39	
SF 298	

List of Figures

Figure 1. Vicinity and location map	2
Figure 2. 1:25-scale model of St. Stephen Powerhouse tailrace	4
Figure 3. 1:25-scale model of type 1 design AAF discharge area	6
Figure 4. 1:5-scale model of the two-conduit AAF design	8
Figure 5. 1:5-scale model of the three-conduit AAF design	11
Figure 6. Side view of the hood, stilling basin and dewatering basin for the type 4 AAF design	28

Preface

This report presents the results of a model investigation authorized by Headquarters, U.S. Army Corps of Engineers, at the request of the U.S. Army Engineer District, Charleston. The model experiments were performed during the period January 1994 to August 1997 by personnel of the Coastal and Hydraulics Laboratory (CHL) of the U.S. Army Engineer Waterways Experiment Station (WES) under the general supervision of Messrs. Frank A. Herrmann (retired) Director, HL; Richard A. Sager (retired), Acting Director, HL; Glenn A. Pickering (retired), Chief Hydraulic Structures Division; Mr. Charles C. Calhoun, Jr., Assistant Director, CHL; and Dr. James Houston, Director, CHL; Dr. Phil G. Combs, Chief of the Rivers and Structures Division; and Mr. John F. George, Chief of the Fisheries and Structural Hydrodynamics Branch. Experiments were conducted by Mr. Thomas E. Murphy, Jr., and Mr. James Cessna of the Fisheries and Structural Hydrodynamics Branch and Dr. John Hite, Jr., of the Locks and Conduits Group in the Rivers and Structures Division, CHL. This report was prepared by Dr. Hite, Mr. Murphy, and Ms. Debra Katzenmeyer.

The models were constructed by the Directorate of Public Works under the supervision of Mr. Dave Haulman, Director of Public Works; Mr. Cecil Dillion, Chief, Operations Division; Mr. James McCoy, Chief, Shops Section; Mr. James Schultz, Chief, Model Shop; and Mr. Paul Beatty, Chief, Welding Shop and Pipe Shop. Messrs. Melvin Bolden, Tommy Beard, Joe Lyons, Mickey Simmons, John Gullett, Kenny Raner, and Chuck Hopkins of the Model Shop constructed the model. Mr. Wilson Jones of the Welding Shop performed the necessary welding and Messrs. Lemoyne Davis, Joe Squire, Jack Townsend, and Joe Taylor of the Pipe Shop performed the pipe work.

During the course of the model study, Mr. James Joslin, Ms. Sara Brown, Ms. Sara Nash, Mr. Mark Nelson, and Mr. Alan Lail of the Charleston District; Mr. Ben Rizzo of the National Fish and Wildlife Service; and Messrs. Doug Cooke, Stuart Coale, and Sam Chappellear of the South Carolina Department of Natural Resources visited WES to view the model and discuss model results.

Director of WES during the preparation of this report was Dr. Robert W. Whalin. Commander was COL Robin R. Cababa, EN.

The contents of this report are not to be used for advertising, publication, or promotional purposes. Citation of trade names does not constitute an official endorsement or approval of the use of such commercial products.

Conversion Factors, Non-SI to SI Units of Measurement

Non-SI units of measurement used in this report can be converted to SI units as follows:

Multiply	By	To Obtain
cubic feet per second	0.45359244	kilograms per second
feet	0.3048	meters
inches	0.0254	millimeters
degrees (angle)	0.01745329	radians
miles (U.S. statute)	1.609344	kilometers

1 Introduction

Background

The St. Stephen Power Plant is located in Berkely County, South Carolina, approximately 1.9 miles¹ north of the town of St. Stephen (Figure 1). It is located in the rediversion canal connecting Lake Moultrie and the Santee River. The powerhouse consists of three main units, each rated 28 Mw. The overall length of the powerhouse is 276 ft and the transverse width is approximately 150 ft at the base.

The fish lift facilities, located on the north side of the powerhouse, were intended to provide a means of transferring various species of game and other desirable fish from the power plant tailrace canal to the intake canal and Lake Moultrie. After several years of fish lift operation at St. Stephen Powerhouse, it was determined that the present facilities were inadequate for transferring the numbers and species of anadromous fish using the St. Stephen tailrace as a migration route to Lake Moultrie. A previous model investigation (Murphy and Hite 1993)² was performed to help improve the fish attraction flow conditions at the fish lift to increase the number of fish using the fish lift. That investigation revealed the fish lift could be improved by providing auxiliary attraction flows to the fish entrances.

The U.S. Army Engineer District, Charleston, proposed an auxiliary attraction flow system that uses a siphon to obtain the auxiliary attraction water from the reservoir. The model investigations reported herein are concerned with evaluation of the flow conditions at the discharge end of the siphon and the hydraulic aspects of the siphon were not addressed. During the course of the investigation, three different models were used for evaluating the flow conditions at the discharge end of the auxiliary flow system.

¹ A table of factors for converting non-SI units of measurement to SI units is presented on page vii.

² Murphy, T. E., Jr., and Hite, J. E., Jr. (1993). "St. Stephen Powerhouse fish lift, Cooper River Rediversion Project, South Carolina," Technical Report HL-93-1, U.S. Army Engineer Waterways Experiment Station, Vicksburg, MS.

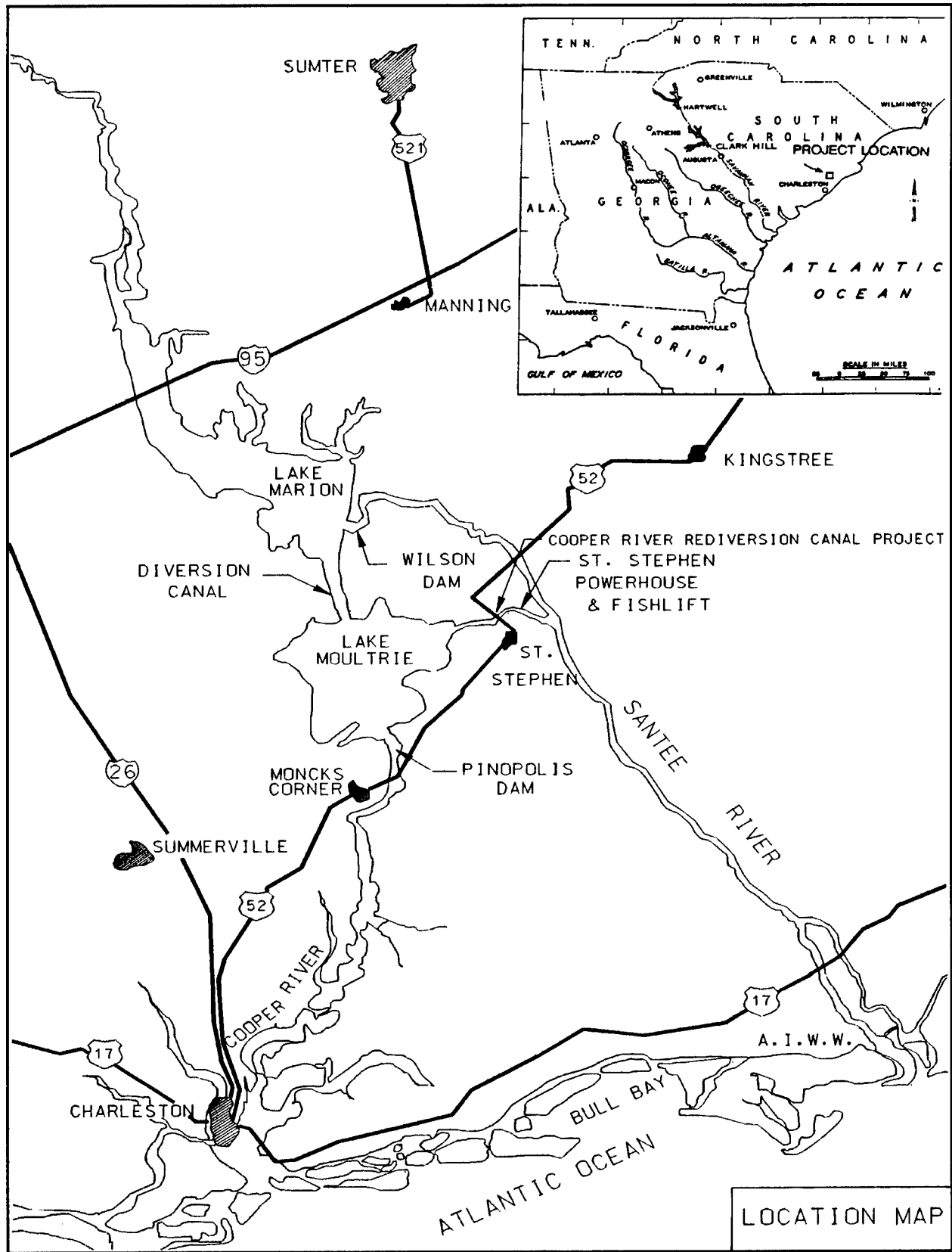
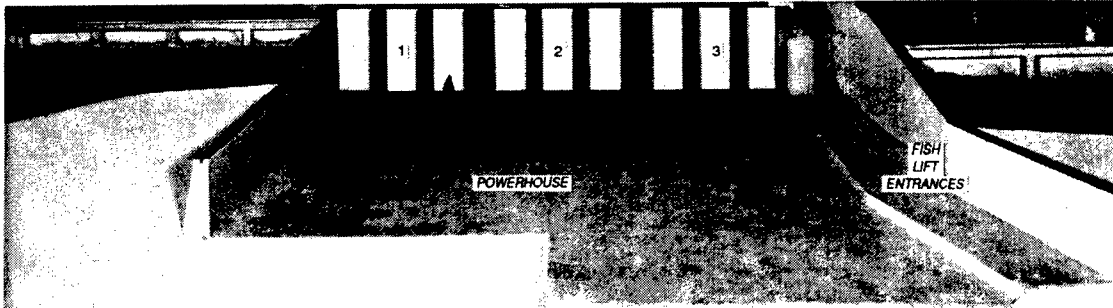

Figure 1. Vicinity and location map

Purpose and Scope of Model Investigations

The 1:25-scale model of the St. Stephen Powerhouse used to improve the fish entrance conditions (Figure 2) was also used for evaluation of the outlet conditions for the initial auxiliary attraction flow system. Specific model experiments were conducted to evaluate the stability of the riprap in the stilling pool and the hydraulic performance of the stilling pool, auxiliary flow channel, and the fish entrance channels.

As the investigation progressed, the design of the siphon discharge system was modified to include downstream fish migration and debris passage. Two 1:5-scale models were required to evaluate flows in the stilling and dewatering basins, since screened sections were contained in these sections. The experiments for these models were conducted to determine the hydraulic performance of the stilling and dewatering basins, the distribution of flow between the flow flume, which carried the auxiliary water to the fish attraction channels, and the transportation channel, which carried downstream migrants and debris to the tailrace, and to make modifications as necessary to achieve the desired performance.



a. Looking upstream toward powerhouse and fish lift entrances

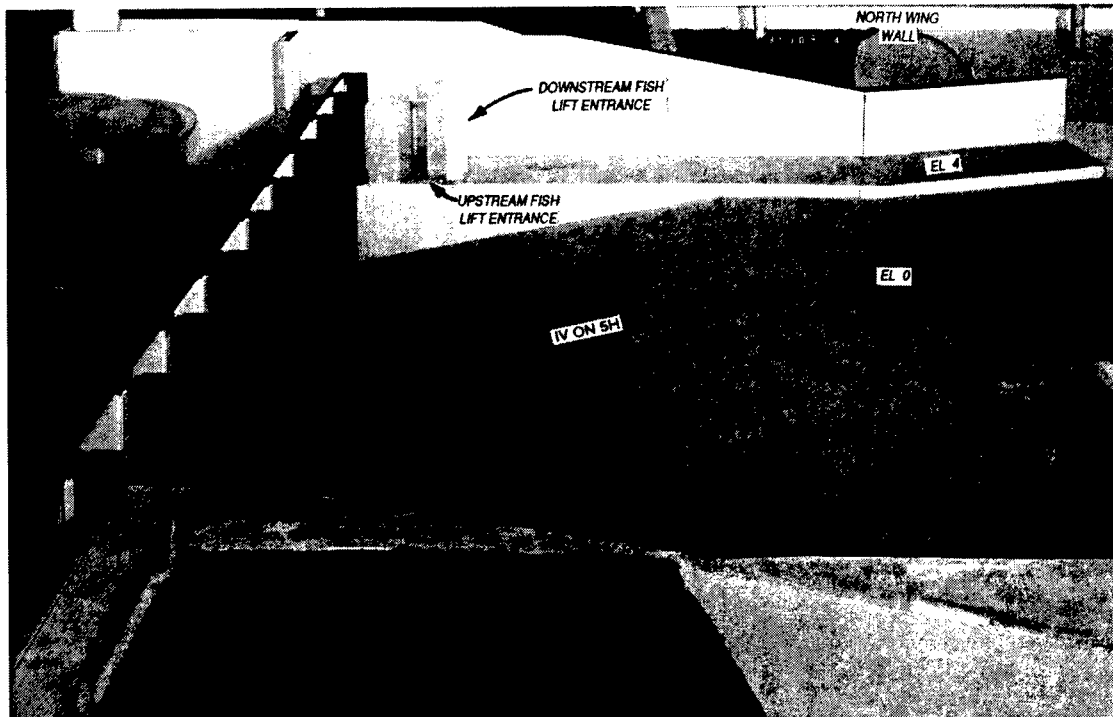

b. Side view looking toward north wing wall and fish lift entrances

Figure 2. 1:25-scale model of St. Stephen Powerhouse tailrace

2 The Models

Description

1:25-scale model

The 1:25-scale model of the initial auxiliary attraction flow (AAF) system discharge area is shown in Figure 3. The AAF system consists of a siphon, which transports water from the reservoir to a stilling pool located on the outside of the left (looking downstream) training wall in the tailrace. Water then flows from the stilling pool over a weir into a 4-ft-wide channel leading to ten 3-ft-high by 4-ft-wide ports. The flow discharges from these ports into the fish channel, which contains two fish entrances. The portions of the auxiliary attraction flow system reproduced in the model are shown in Plate 1 and Figure 3. This system was designated the type 1 design AAF system. A 200-ft-length of the end of the 60-in. conduit set at the proper slope was used to reproduce the correct energy grade line at the outlet. The stilling pool, trash screen, ported attraction flow channel, and fish channels were also reproduced.

The 200-ft-length of siphon conduit was constructed of plastic pipe. The stilling pool was built of sand, filter cloth, and riprap. The ported attraction flow channel and the fish channels were constructed of sheet metal, plastic, and plastic-coated plywood. The tailrace area was constructed of sand and cement mortar molded to sheet metal templates.

1.5-scale two-conduit model

Previous experience with physical models used to evaluate flow conditions in dewatering systems containing screening materials has shown that the model needs to be large enough to avoid near-field viscous effects in the vicinity of the screen. The modeling technique employed usually consists of using the actual screening material in the model that will be used in the prototype and sizing the model to avoid unrealistic losses through the screen. A 1:5-scale model was determined to be appropriate for the proposed auxiliary attraction flow system for the St. Stephen Project. The layout for the first 1:5-scale model is shown in Plate 2 and photographs of the model are shown in Figure 4. This design was

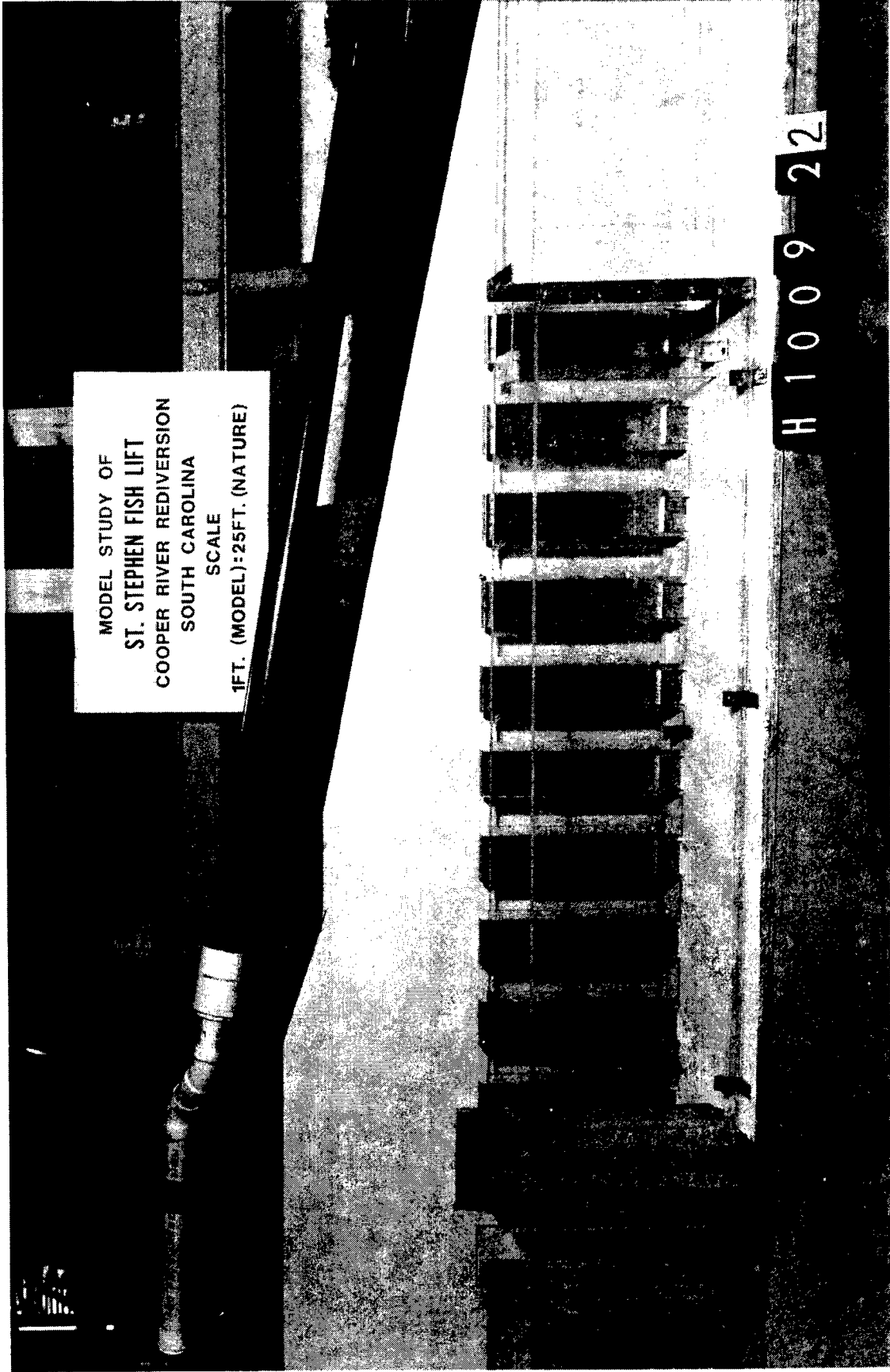

MODEL STUDY OF
ST. STEPHEN FISH LIFT
COOPER RIVER REDIVERSION
SOUTH CAROLINA
SCALE
1FT. (MODEL):25FT. (NATURE)

H 1009 22

a. Side view looking toward north wing wall

Figure 3. 1:25-scale model of type 1 design AAF discharge area

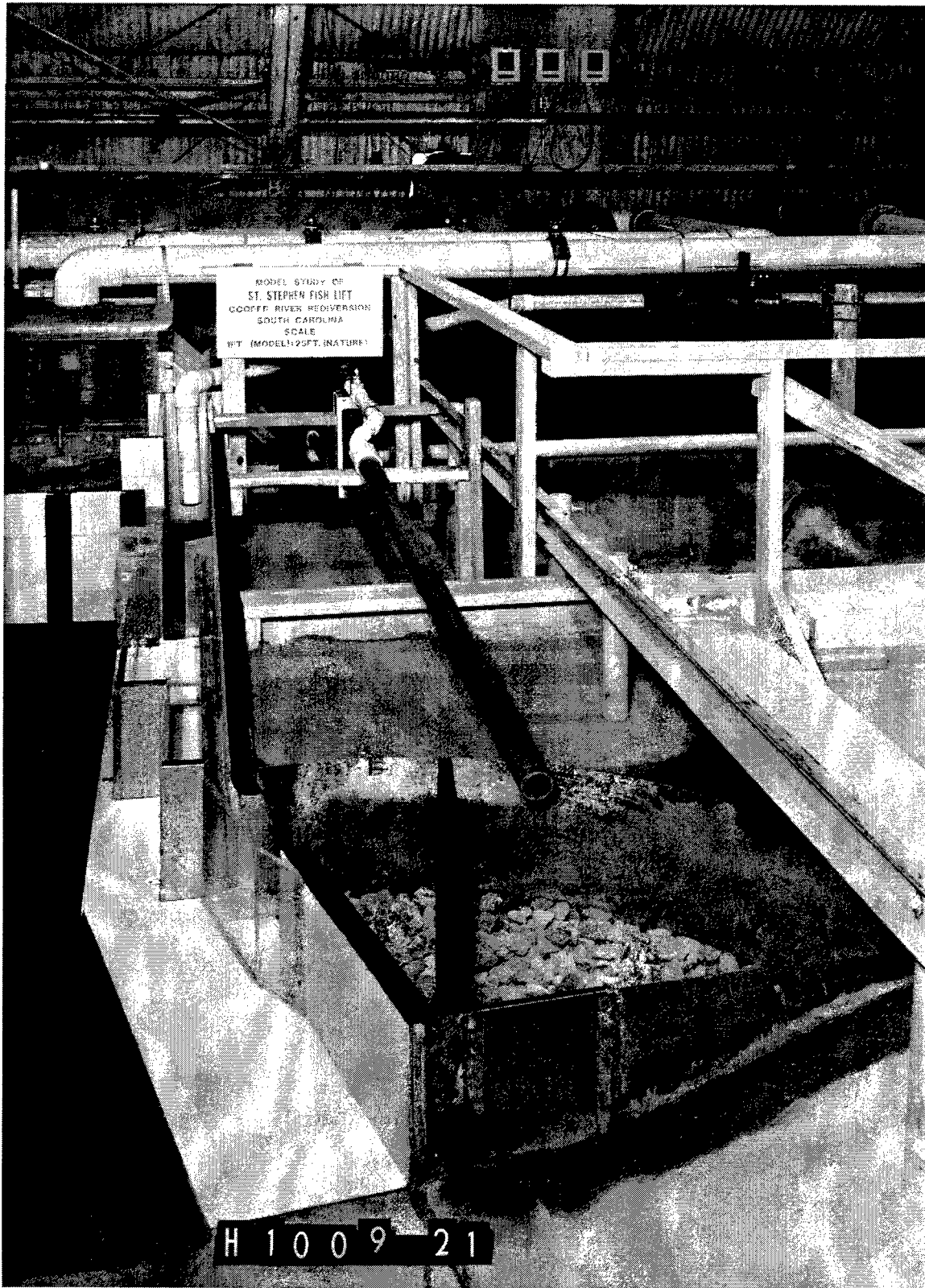

b. Looking upstream

Figure 3. 1:25-scale model of type 1 design AAF discharge area



a. Looking downstream at the two 54-in.-diam conduits and the basin for the fish and flow flumes

Figure 4. 1:5-scale of the two-conduit AAF design

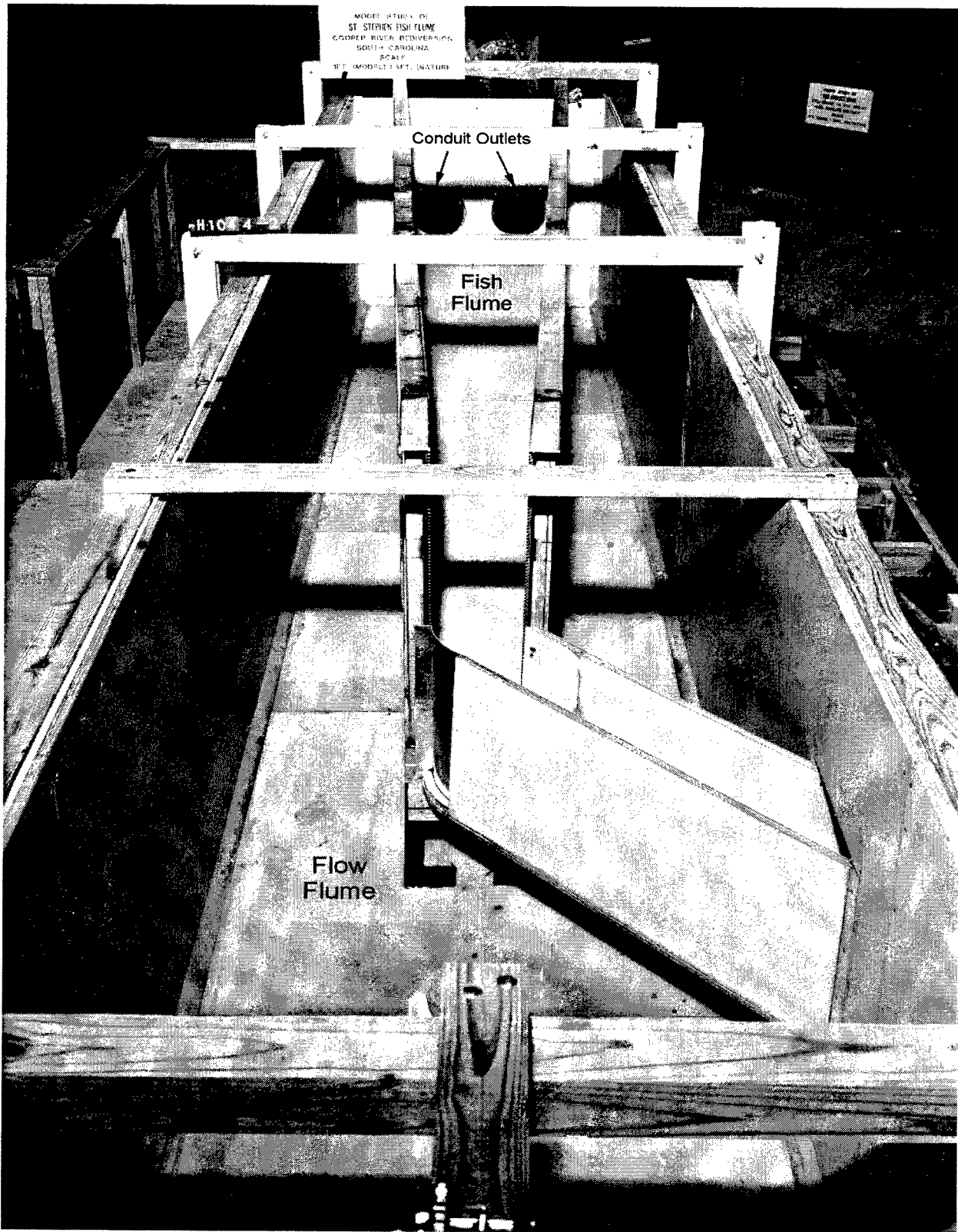

b. Looking upstream at the fish and flow flumes

Figure 4. 1:5-scale model of the two-conduit AAF design

designated the type 3 design AAF system and the model reproduced the lower 200-ft section of the two 54-in.-diam conduits which were proposed for the siphon, the 20-ft-wide by 110-ft-long flow flume, and a transportation channel which transitioned from 12 ft wide at the siphon outlet to 3 ft wide 80 ft downstream from the outlet. The invert elevation of the flow flume at the siphon outlet was 24.95 and the bottom slope was 0.0023 ft/ft. The invert of the fish flume was el 32 with a bottom slope of 0.017 ft/ft. At a distance of 80 ft downstream from the outlet, the fish flume angled 135 deg to the left (looking downstream), continued through the wall of the flow flume, and discharged over the north wing wall.

The two 54-in.-diam conduits were made of acrylic plastic and fabricated at the U.S. Army Engineer Waterways Experiment Station. The sides of the fish flume in the transition section were made of plastic-coated plywood and stainless steel wedgewire screen with 1/8-in.-wide bars spaced 1/8 in. apart. The sides of the 3-ft-wide section of the fish flume were constructed of plastic-coated plywood in the straight section and sheet metal in the angled section. The floor of the fish flume was constructed of plastic-coated plywood. The flow flume was constructed of plastic-coated plywood.

The fish flume was designed as a dewatering system where a certain percentage of flow discharging from the siphon outlet into the fish flume would pass through the wedgewire screen sides and drop into the flow flume to be carried away and used for auxiliary attraction flow for the fish lift system. The flow remaining in the fish flume would be used to transport downstream migrants and possibly any small debris entering the siphon to a desired location in the tailrace. The desired distribution of flow for a siphon discharge of 600 cfs was 93 percent in the flow flume and 7 percent at the downstream end of the fish flume.

1:5-scale three-conduit model

A second 1:5-scale model of the stilling basin and dewatering basin for the auxiliary attraction flow system was constructed because the outlet elevation of the type 3 AAF system had to be raised in an attempt to improve flow conditions from those observed with the type 3 AAF system. The layout is shown in Plate 3 and photographs of the model are shown in Figure 5. This model was designated the type 4 design AAF system. The initial design reproduced the lower 165-ft portion of the three 36.9-in. inside diameter conduits proposed for the siphon, the stilling basin (which transitioned from 14.5 ft wide at the outlet to 20 ft wide at a distance 25 ft downstream from the outlet), and a 37-ft-long by 20-ft-wide dewatering flume downstream from the stilling basin. The model also reproduced the wedgewire screen (1/8-in. bars spaced 1/4 in. apart) inside the dewatering flume, a 25-ft section of the three 35.6-in. inside diameter conduits and control valves used to carry the auxiliary attraction flow from the dewatering flume to the tailrace, and a section of the transportation channel that was used to carry downstream migrants and small debris to the

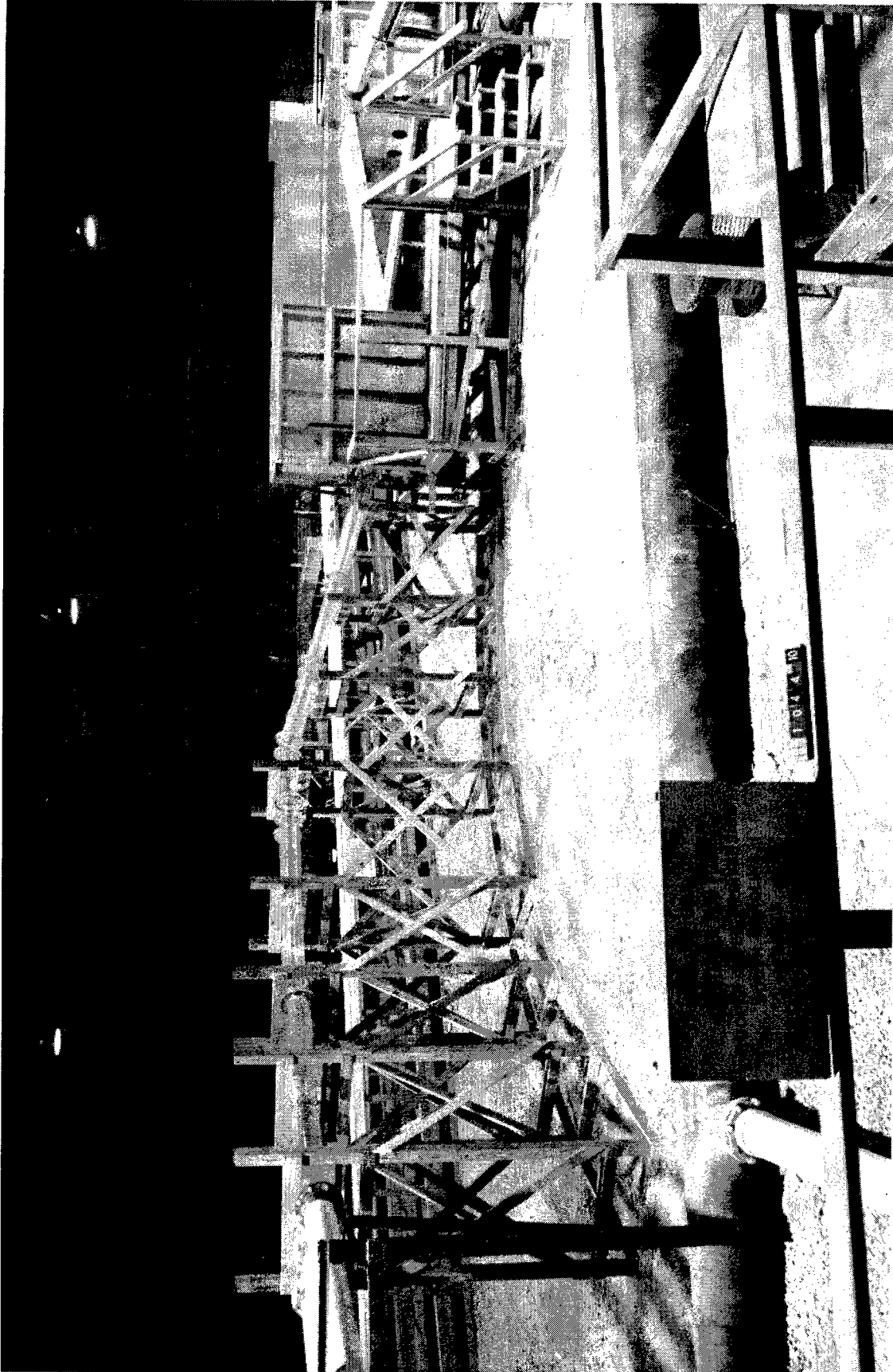

a. Overall view of type 4 design

Figure 5. 1:5-scale model of the three-conduit AAF design

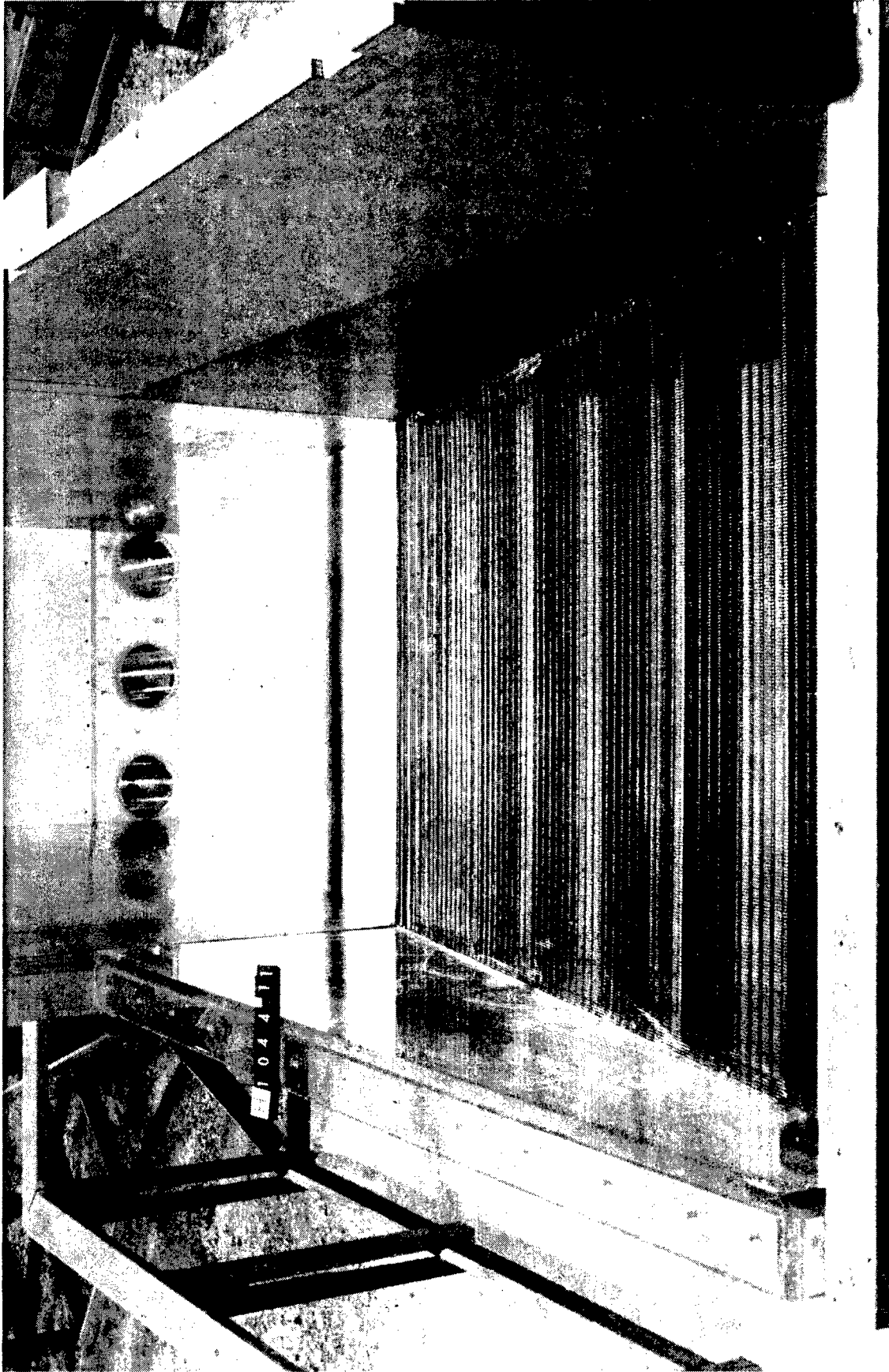

b. Looking upstream at the conduit outlet

Figure 5: 1:5-scale model of the three-conduit AAF design

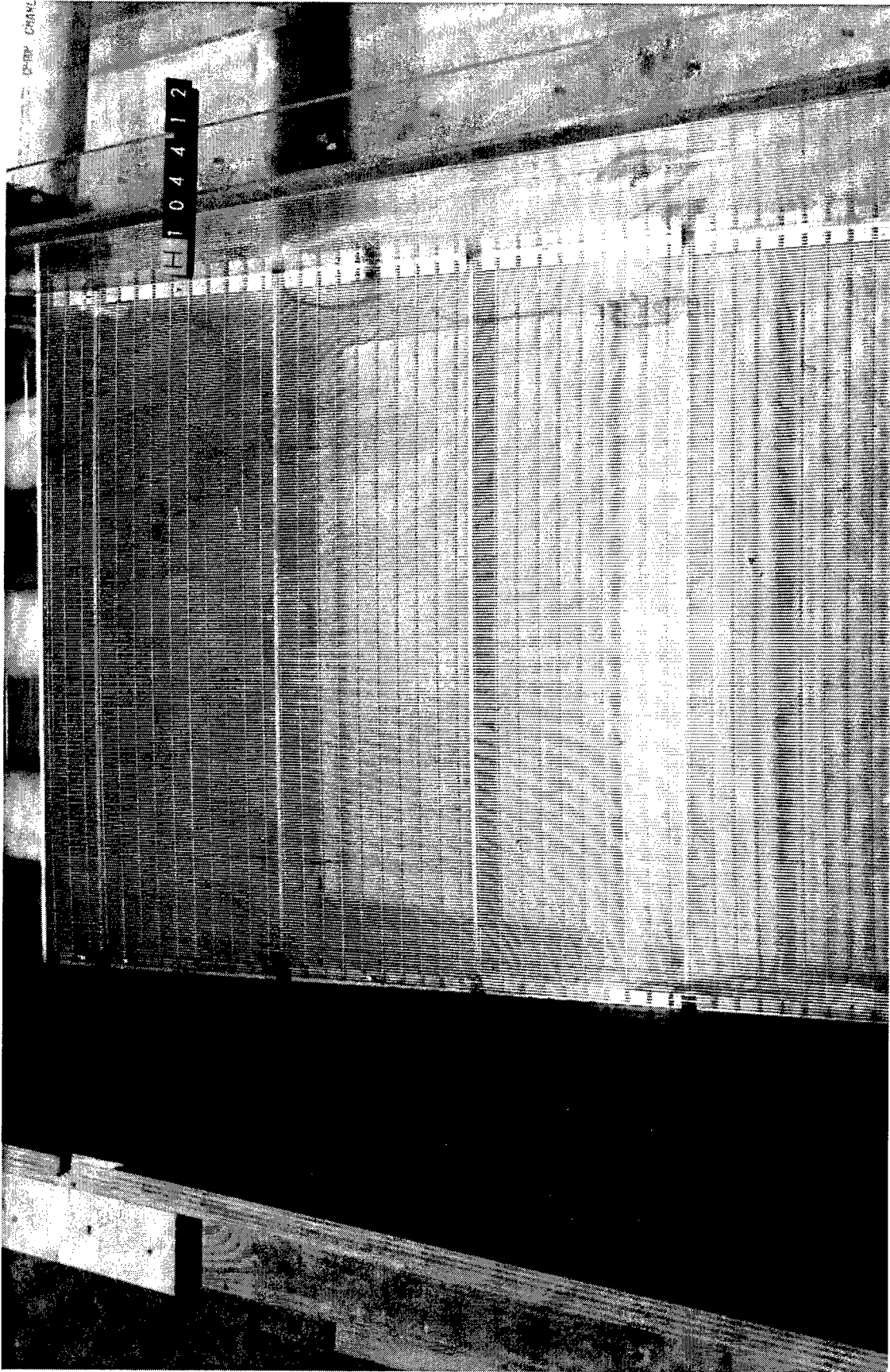

c. Looking downstream at the sloped wedgewire screen

Figure 5. 1:5-scale model of the three-conduit AAF design

tailrace. The invert of the three conduits was el 42, which was also the stilling basin floor invert elevation. The upstream invert of the wedgewire screen was el 42 and the downstream elevation was 49.6 where the flow discharged into the transportation channel. The invert of the three conduits in the dewatering flume was el 36.4.

The three siphon conduits were constructed of (HDPE) pipe. The stilling basin, dewatering flume, and transportation channel were constructed of plastic-coated plywood, plastic, and sheet metal. The three conduits for the dewatering flume were constructed from polyvinyl chloride (PVC) pipe.

The concept for this design was similar to that of the previous design. A certain percentage of the flow discharging from the siphon into the basin would be used for auxiliary attraction flow for the fish lift and the remaining flow would be used to transport downstream migrants and possibly any small debris that entered the siphon to a desired location in the tailrace. The desired flow distribution with a siphon discharge of 450 cfs was 93 percent for auxiliary attraction flow and 7 percent for transportation.

Model Appurtenances

Water used to operate the models was supplied by circulating systems. Discharges were measured with venturis and paddle wheel flow meters installed in the inflow lines and V-notch weirs. Sufficient lengths of conduit were constructed to provide the desirable upstream boundary conditions. Water-surface elevations were measured with point gauges. Velocities were measured with propeller type meters mounted to permit measurements at any horizontal direction and depth and three-dimensional acoustic doppler velocity probes. The tailwater was maintained at the desired depth by means of an adjustable tailgate in the 1:25-scale model and the two-conduit 1:5-scale model and with control valves mounted on the discharge conduits in the three-conduit 1:5-scale model. Dye and confetti were used to study subsurface and surface current directions. Photographs and video recorded the various flow conditions.

Scale Relations

The accepted equations of hydraulic similitude, based on Froudian relations, were used to express mathematical relations between the dimensions and hydraulic quantities of the model and prototype. General relations for the transfer of the model data to prototype equivalents, or vice versa, are presented in the following tabulation:

Characteristic Model:Prototype	Dimensions ¹		
Length	$L_r = L$	1:25	1:5
Area	$A_r = L_r^2$	1:625	1:25
Velocity	$V_r = L_r^{1/2}$	1:5	1:2.236
Discharge	$Q_r = L_r^{5/2}$	1:3,125	1:55.902
Volume	$V_r = L_r^3$	1:15,625	1:125
Weight	$W_r = L_r^3$	1:15,625	1:125
Time	$T_r = L_r^{1/2}$	1:5	1:2.236
¹ Dimensions are in terms of length.			

Certain model data can be accepted quantitatively, while other data are reliable only in a qualitative sense because of the nature of the phenomena. Measurements in the model of discharges, water-surface elevations, velocities, and resistance to displacement of riprap material can be transferred quantitatively from model to prototype using the preceding scale relations.

3 Experimental Results

1:25-Scale Type 1 Design AAF System

Type 1 riprap design

Initial experiments were conducted to evaluate the stability of the riprap placed at the bottom of the stilling pool. The flow conditions that normally exist during the peak periods of upward migration are a powerhouse discharge of 21,300 cfs and a tailwater elevation of 26. These are the conditions where the fish lift modification needs to operate most efficiently. The type 1 riprap design consisted of a d_{50} size stone of 30 in. with a blanket thickness of 72 in. placed in the stilling pool with the top of the blanket at el 4. The gradation for this design is shown in Plate 4. An experiment conducted with 500 cfs discharging from the 60-in.-diam conduit (auxiliary attraction flow (AAF)), 21,300 cfs from the powerhouse, and a tailwater elevation of 26, indicated this design was stable.

The type 1 riprap was also stable with 250 cfs discharging from the main attraction flow (MAF) and 250 from the auxiliary attraction flow, a powerhouse discharge of 21,300 cfs, and a tailwater elevation of 26. These results indicated the type 1 riprap design would remain stable for discharges up to 500 cfs from the auxiliary attraction flow with a tailwater elevation of 26. The other portions of the auxiliary attraction flow system were evaluated next rather than change the initial riprap design.

Water-surface elevations

Experiments were conducted next to determine water-surface elevations at various locations in the auxiliary attraction flow system. The water-surface stations for these experiments are shown in Plate 5. The measurements obtained at these stations for three combinations of the main and auxiliary attraction flows are shown in Table 1 with a powerhouse discharge of 21,300 cfs and a tailwater elevation of 26. The water surface was very choppy at station A due to the jet discharging into the stilling pool. The experiments indicated the minimum elevation of the top of the wall in the stilling pool needed to be 30 for the condition with 500 cfs from both the main and auxiliary attraction flows.

Flow distribution in fish channel

Experiments were conducted next to observe flow conditions in the fish channel. The direction of the flow jets discharging from the ports was documented by injecting dye upstream from the ports. Plates 6-8 indicate the direction of the flow exiting the ports for the three combinations of main and auxiliary attraction flows. The experiments indicated the flow jets exited the 3-ft-wide by 4-ft-high ports in an upstream direction with discharges between 250 and 500 cfs from the auxiliary attraction flow. This caused flow in the lower depths of the fish channel to be turbulent and in the wrong direction desired for fish movement. Flow in the upper half of the fish channel was generally in a downstream direction and favorable for fish movement.

Velocities were measured at the center of each port 0.75 ft off the floor to evaluate the flow distribution from the ports. The meter was oriented to obtain the average velocity component normal to the right wall of the fish channel. The velocities from these experiments are shown in Table 2. The velocities indicate the strongest cross-stream component occurs at port No. 1 and the smallest cross-stream component occurs at port No. 10. This was apparent for all three combinations of MAF and AAF.

Additional velocities were measured at three cross sections inside the fish channel to further evaluate the flow patterns. The cross sections were designated the upstream range, which was located 1 ft downstream from the beginning of the right wall; the middle range, located 45 ft downstream from the beginning of the right wall; and the downstream range, located 1 ft upstream from the beginning of the right wall of the downstream fish entrance. The locations of these cross sections are shown in Plate 5. The meter was oriented to measure the average downstream component of the velocity at most of the locations. Some of the velocities near the bottom were measured normal to the right wall and are noted as such.

The measurements obtained with a powerhouse discharge of 21,300 cfs, a tailwater elevation of 26, an MAF of 500 cfs, and an AAF of 500 cfs are shown in Plate 9. The velocities measured from 5 ft off the floor to the surface were in a downstream direction. The velocities measured near the floor indicated the flow was towards the right wall of the fish channel. The flow discharging from the ports impacted the right wall and was redirected towards the surface. The maximum velocity in a downstream direction was measured at the downstream range and was 5.7 ft/sec.

The velocity measurements obtained in the fish channel with an MAF of 0 cfs and an AAF of 500 cfs are shown in Plate 10 and the measurements obtained with an MAF of 250 cfs and an AAF of 250 cfs are shown in Plate 11. These velocities were lower than those measured with an MAF of 500 cfs and an AAF of 500 cfs. The maximum downstream velocity was 3.2 ft/sec and was measured at the upstream and downstream ranges. The velocities measured in the fish channel indicated the flow from about 5 ft off the bottom to surface was generally in a downstream direction. Swirling flow was present downstream

from the end of the downstream existing fish entrance, which, with the new fishlift modification, is the beginning of the right wall of the fish channel. Flow near the bottom of the channel was towards the right wall. Modifications were performed next in an effort to improve the flow conditions in the fish channel.

1:25-Scale Type 2 Design AAF System

The auxiliary attraction inflow was modified from one 60-in.-diam pipe to two 48-in.-diam pipes. A 50-percent porosity plate was placed in the fish channels at el 8.5 to represent a floor grate at this elevation. The type 1 riprap in the plunge pool was replaced with the type 2 riprap design, which consisted of a D_{50} size stone of 24 in. and a blanket thickness of 48 in. placed to conform to the existing topography. The type 2 riprap design is shown in Plate 12 and the gradation for this design is shown in Plate 13. These changes were designated the type 2 design auxiliary attraction flow system.

Experiments were conducted to observe flow conditions in the fish channels with an MAF of 150 cfs and an AAF of 500 cfs, 250 cfs through each of the 48-in.-diam pipes. Velocities were measured at the three cross sections inside the fish channel, as discussed previously (Plate 5). The cross sections were designated the upstream range, which was located 1 ft downstream from the beginning of the right wall; the middle range, located 45 ft downstream from the beginning of the right wall; and the downstream range, located 1 ft upstream from the beginning of the right wall of the downstream fish entrance. The velocity meter was oriented to measure the average downstream component of the velocity at most of the locations. Velocity measurements obtained with a powerhouse discharge of 21,300 cfs and a tailwater elevation of 26.0 are shown in Plate 14. The velocities for the upstream range indicate the areas along the left and right walls have little or no flow in the downstream direction. The downstream flow at this range is concentrated in the center of the channel. Flow increases and spreads throughout the channel further down the fish channel due to the additional flow from the ports. The velocities at the downstream range vary from 0.9 to 4.7 ft/sec.

Water-surface elevations were also measured with the type 2 design AAF system. The water-surface stations are similar to those with the type 1 design AAF system and are shown in Plate 5. The elevations with the type 2 design AAF system and a powerhouse discharge of 21,300 cfs, MAF of 150 cfs, AAF of 500 cfs, and a tailwater elevation of 26.0 are listed in Table 3. Additional water-surface elevations with a powerhouse discharge of 7,100 cfs and tailwater elevations of 12.0 and 16.6 are also provided in Table 3.

Type 2 floor grate

The 50 percent porosity plate representing the floor grate was raised from el 8.5 to el 11 at the request of the Charleston District and was designated the

type 2 floor grate. Velocities were measured in the fish channel with this modification and are shown in Plate 15. Velocities above the floor grate were slightly higher than those measured with the grate at el 8.5, but the flow conditions in the fish channel were similar. The flow at the upstream range was still concentrated in the center of the channel and began to spread throughout the channel farther downstream. The velocities at the downstream range varied from 1.2 to 5.0 ft/sec.

Type 2 ported channel design

The Charleston District requested that the channel from the plunge pool to the ports be widened from 4 to 6 ft and that ports 9 and 10 be closed. Ports 9 and 10 were the last two downstream ports on the left wall. This modification was designated the type 2 ported channel design and the type 2 floor grate was left in place. Velocities measured in the fish channel with this design are shown in Plate 16. Flow conditions were improved in the fish channel with this design. The flow was not as concentrated at the upstream range and was distributed better at the downstream range. The velocities at the downstream range varied from 2.3 to 4.1 ft/sec as shown in Plate 16. Water-surface elevations were also measured with the type 2 ported channel design and are listed in Table 4.

Type 3 floor grate

A 3-ft-wide solid plate was placed on the floor grate along the outside wall of the fish channel to try and reduce the upwelling of flow at the wall and possibly spread the flow better in the fish channel. This change was designated the type 3 floor grate. Dye was injected in the fish channel to observe the flow conditions. This size plate caused too much of the flow to be redirected back to the left wall of the fish channel.

Type 4 floor grate

The solid plate was reduced in width from 3 to 2 ft (type 4 floor grate). Velocities measured in the fish channel with this design are shown in Plate 17. Flow conditions were improved at the middle range and velocities were slightly higher at the downstream range on the outside wall and slightly lower on the inside wall. Flow conditions were similar at the upstream range. Since flow conditions were improved at the middle range and were not much different at the other two ranges compared to the type 2 ported channel design, further experiments were performed with the type 4 floor grate. Water-surface elevations were also measured with the type 4 floor grate and are provided in Table 5. These elevations were the same as those measured with the type 2 floor grate and type 2 ported channel design in Table 4.

Velocities were measured in the fish channel with the type 4 floor grate for different powerhouse discharges and tailwater conditions. The MAF and AAF

were kept the same, 150 and 500 cfs, respectively. The weir elevations at the entrances were adjusted according to the tailwater elevation in an effort to maintain similar velocities at the entrances. These weir elevations are shown in Table 6. Velocities measured with a powerhouse discharge of 21,300 cfs and a tailwater elevation of 23.1 are shown in Plate 18. The velocities indicated the flow patterns in the fish channel were similar to conditions with the tailwater elevation of 26.0 and slightly larger in magnitude. Water-surface elevations measured with these conditions are shown in Table 5.

Velocities measured with a powerhouse discharge of 14,200 cfs and a tailwater elevation of 20.9 are shown in Plate 19. Velocities greater than 4.0 ft/sec were prevalent at the middle and downstream ranges. Water-surface elevations measured with these conditions are shown in Table 5.

Velocities measured with a powerhouse discharge of 7,100 cfs and a tailwater elevation of 16.6 are shown in Plate 20. Velocities greater than 4.0 ft/sec were measured at all three ranges, and velocities up to 5.8 ft/sec were measured at the downstream ranges. Water-surface elevations measured with these conditions are shown in Table 5.

Type 2 riprap design

The type 2 riprap design shown in Plate 12 was in place for all experiments described above. Before these experiments were conducted, a riprap test was performed with an AAF of 500 cfs, MAF of 150 cfs, a powerhouse discharge of 21,300 cfs, and a tailwater elevation of 26.0. This experiment was conducted for 1 hr model time (equivalent to 5 hr prototype) and riprap movement was detected at the location shown in Plate 21. This movement is not desirable, although the filter cloth underneath the riprap blanket was not exposed. Throughout the remaining experiments to measure velocities in the fish channel, the riprap was never repaired and the filter cloth underneath the rock was not exposed at the end of these experiments.

Summary of Types 1 and 2 Design AAF Systems

Velocities measured in the fish channel for the various designs and flow conditions described for the types 1 and 2 AAF systems indicate the flow at the upstream portion of the fish channel is not uniform and tends to concentrate near the center and left side of the fish channel. The flow becomes more uniform as it moves down the channel. The lower the tailwater, the more uniform the flow becomes at the downstream range. Closing ports 9 and 10 tended to distribute the flow better, as can be seen by comparing Plate 17 with Plate 15. The 50-percent porosity plate was used to represent a floor grate placed at el 11. If a flow diffuser and baffling system is actually used in the prototype and placed below the floor grate, more head loss will occur than modeled with the porosity plate. Additional head loss will probably improve the flow conditions in the fish

channel above el 11 by distributing it better in the fish channel. The experiments with the solid plate placed on the outside of the floor grate were conducted to try and distribute the flow better in the fish channel without placing baffles underneath the floor grate.

1:5-Scale Type 3 Design AAF System

Initial experiments were performed with the type 3 design AAF system (Plate 3 and Figure 4) to observe the flow conditions and to determine the flow distribution between the flow flume and the fish flume. A total of 600 cfs, split equally between the two 54-in.-diam conduits, was discharged into the basin. Approximately 43 percent of the flow discharged from the fish flume. The desired flow distribution was 7 percent in the fish flume and 93 percent in the flow flume. High-velocity flow (>20 ft/sec) occurred in the transition section of the fish flume and as the flow entered the 135-deg bend, it rode up the outside wall and spilled over the top of the wall. The lower 6 in. of the side walls in the transition section were solid, and above that, the walls were constructed of wedgewire screen. Flow conditions in the fish flume with a discharge of 600 cfs are shown in Photo 1 and velocities and water-surface profiles measured in the fish flume with this discharge are shown in Plate 22. High velocities in the fish flume made these conditions undesirable for fish passage.

Experiments were performed next with a total of 400 cfs discharging into the basin with 200 cfs from each conduit. At the end of the basin, approximately 48 percent of the flow discharged from the fish flume and 52 percent from the flow flume. High-velocity flow was again observed in the transition section and the flow rode up the outside wall entering the curve, but did not spill over the top of the wall. Flow conditions in the fish flume with a discharge of 400 cfs are shown in Photo 2 and velocities and water-surface profiles measured with this discharge are shown in Plate 22.

Flow conditions were observed in the fish flume with the water surface in the flow flume raised to el 33 to evaluate the effect of submerging the outlet. Photos 3 and 4 show these flow conditions with discharges of 600 and 400 cfs, respectively. This water level had little effect on the flow conditions in the fish flume; high velocities still occurred. These flow conditions were also not desirable for fish passage.

Type 2 design fish flume

The floor of the fish flume was raised to horizontal (no slope) in an effort to reduce the velocities in the wedge wire portion of the flume and increase the amount of flow in the flow flume. With a discharge of 600 cfs entering the basin, approximately 39 percent of the flow exited the fish flume. High-velocity flow still occurred in the transition section of the fish flume and flow spilled

over at the entrance to the bend. This modification did not improve conditions in the fish flume significantly.

Type 3 design fish flume

Wedgewire screen was placed on the invert of the fish flume from the outlet to a distance of 40 ft downstream from the outlet as shown in Plate 23. This modification improved the flow distribution between the flow flume and fish flume. With an inflow of 600 cfs, approximately 10 percent of the flow exited the fish flume. However, for discharges lower than 550 cfs, all the inflow discharged through the screens, leaving no flow for transporting fish and small debris.

Type 4 design fish flume

The invert of the fish flume was made solid again for the first 20 ft downstream from the outlet and wedgewire screen was placed on the invert from 20 to 40 ft downstream. A flow divider was also installed between the conduit outlets on the fish flume invert. These modifications were designated the type 4 design fish flume and are shown in Plate 24. Visual observations indicated a significant portion of the inflow was exiting the fish flume, so additional modifications were made.

Type 5 design fish flume

The original design transition section of the fish flume was placed back in the model and the straight section of flume downstream from the bend (39 ft in length) was modified to observe the effect of different slopes in this section. The first experiment was conducted with a 15-deg upslope beginning at the end of the bend and terminating at the end of the channel (type 5 design fish flume). With a discharge of 600 cfs, there was not enough velocity head to cause flow over the end of the sloped section and 100 percent of the flow discharged through the flow flume.

Type 6 design fish flume

The upslope was reduced to 10 deg (type 6 design fish flume) and an experiment was performed with a total inflow of 600 cfs. Visual observations revealed that only a small percentage, estimated at less than 3 percent, of the flow exited the fish flume. A hydraulic jump formed in the fish flume with the toe of the jump moving back and forth between 70 and 75 ft downstream from the outlet. The fluctuating jump caused the flow to exit the fish flume in a surging manner.

Type 7 design fish flume

The upslope was reduced to 5 deg (type 7 design fish flume). With a discharge of 600 cfs entering the basin, 25 percent of the flow exited the fish flume. A relatively stable jump formed approximately 75 ft downstream from the outlet, as shown in Photo 5. The results from experiments with the type 6 and 7 fish flumes indicated an acceptable flow could be established through the fish flume by adjusting the slope of the lower 39 ft of the flume. However, this method caused a hydraulic jump to form upstream from the bend and was not considered desirable for fish passage. Baffles were also placed in the type 7 design fish flume at various locations upstream from the bend to try and move the jump upstream and reduce velocities through the bend. The supercritical flow sprayed off the baffles producing undesirable flow conditions, so this approach was abandoned.

Type 8 design fish flume

The lower 6-in. solid section of the side walls in the transition section of the fish flume was replaced with wedge-wire screen and the left side of the fish flume between the bend and the left wall of the flow flume was also replaced with wedge-wire screen to form the type 8 design fish flume. The 5 deg upslope in the lower portion of the fish flume was not changed. With a discharge of 600 cfs entering the basin, 23 percent of the flow exited the fish flume. Flow conditions in the flume were similar to those observed with the type 7 design and were still not considered acceptable for fish passage.

Type 9 design fish flume

Solid walls were placed back in the fish flume downstream from the bend and a 60-ft section of wedge-wire screen was placed on the invert of the transition section 30 ft from the outlet, as shown in Plate 25. A triangular-shaped orifice was placed inside the conduits 5 ft upstream from the downstream end of the conduits to observe discharge less than 300 cfs per pipe. This shape was used to produce jet flow entering the basin similar to that which would occur with a flexible pinch valve partially closed. An experiment conducted with 130 cfs discharging from the right (looking downstream) conduit indicated that 7 percent of the flow (9 cfs) exited the fish flume.

Experiments performed on the 1:5-scale two-conduit model revealed that the desired flow distributions could be achieved by modifying the screened floor of the fish flume and adjusting the slope of the section downstream from the bend. However, the hydraulic flow conditions in the fish flume were not desirable for fish passage with these type modifications. Due to the high velocities against the screens which were not favorable for fish passage, and the need to raise the conduit outlet from el 32 to el 42, the design concept using a fish flume located above the flow flume was changed.

1:5-Scale Type 4 Design AAF System

The new design concept used a stilling basin at the conduit outlet to dissipate the energy of the flow and provide length for the flow to distribute spatially and a dewatering basin at the end of the stilling basin. The dewatering basin was used to separate the auxiliary attraction flow and the transportation channel flow. The Charleston District had determined that a total discharge of 470 cfs from the auxiliary attraction flow system would be adequate to improve fish attraction to the fish lift system in the tailrace. Initial experiments with the type 4 design AAF system (Plate 3) were performed with a total inflow of 470 cfs (divided equally among the three conduits) and a tailwater elevation of 50 in the stilling basin. In the type 4 design AAF system, the level 25-ft-long flume section with an invert elevation of 42 was referred to as the stilling basin and the 37-ft-long sloping flume section downstream from the stilling basin was referred to as the dewatering basin.

Velocity measurements were obtained at selected locations within the dewatering basin to evaluate the flows in this basin. The velocity stations designated 1-6 in the streamwise direction are shown in Plate 26. Time-histories of velocity were obtained using a three-dimensional acoustic doppler probe. Time histories of the x-component (streamwise direction) and z-component (depthwise or surface to bottom direction) of velocity measured at station 1, (5 in. above the screen at the center of the flume) are shown in Plate 27. The velocities fluctuated significantly in both magnitude and direction. The x-component varied from a maximum value of 18.5 to 0 ft/sec and the z-component varied between 4.0 ft/sec towards the surface to -1.1 ft/sec towards the screen at station 1. These velocities are indicative of a highly turbulent flow field and suggested that significant energy dissipation was occurring at this location on the screen. Average, maximum, and minimum velocities obtained from the time-histories measured 5 in. (0.42 ft) above the screen at stations 1-6 are provided in Table 7. Velocity fluctuations are still quite high at station 2 and tend to reduce in the downstream direction. In a highly fluctuating flow field, an average velocity should not be used to characterize the entire flow field. Plate 28 is a general depiction of the flow in the basin. Flow at the toe of the screen is drawn up through the screen toward the surface. The screen tends to act as a deflector near the toe and is not effective in passing flow through it. Between station 3 and station 4, flow begins to pass through the screen with a downward component.

Velocities obtained from time-histories at station 1 throughout the depth and at the center of the basin are provided in Table 8. These velocities also indicate the flow field is highly turbulent and modifications were necessary to try and produce flows more suitable for fish and debris passage. The flow distribution with an inflow of 470 cfs and a water-surface elevation in the basin of 50 was 60 cfs exiting the transportation channel and 410 cfs discharging from the three outlet conduits. The y-component (cross-stream direction) of velocity was not large at the locations discussed above compared to the x- and z- components.

Long, Steffler, and Rajaratnam (1990)¹ investigated the flow structure for submerged hydraulic jumps in a horizontal rectangular channel of constant width. They found that in the developing region of the jump, the flow is three-dimensional. After the jump, the flow will recover into a two-dimensional flow. Velocity measurements made in the dewatering basin for the remaining experiments were considered to be in the recovered zone of the jump and therefore only the x- and z- components are discussed.

Type 2 dewatering basin

In an effort to increase the flow through the screen at the toe, the floor of the dewatering basin was lowered 3 ft from el 42 to el 39. This modification was designated the type 2 dewatering basin as shown in Plate 29. The x- and z-components of the average, maximum, and minimum velocities obtained from measurements taken 5 in. above the screen are listed in Table 9. The turbulence levels with this design were reduced slightly. The average downstream velocities were higher between stations 3 and 6, but the variance in velocity was not as high. The z-component of velocity was not as varied at all stations except station 1. Time-histories of the x-component (streamwise direction) and z-component (depthwise) of velocity measured at station 1(5 in. from the screen) are shown in Plate 30. Upon close inspection of the time-histories, a reduction in velocity fluctuations in the z-component can be seen when compared to those in Plate 27.

Velocities obtained from time-histories at station 1 throughout the depth and at the center of the basin are provided in Table 10. These velocities indicate there was not much change in the flow field at station 1 throughout the depth when compared to those obtained with the type 1 design stilling basin. Plate 31 is a general depiction of the flow in the type 2 dewatering basin. Recirculating flow occurred just downstream from the step, causing flow at the toe of the screen to be drawn up through the screen toward the surface. However, downward flow through the screen occurred closer upstream than with the type 1 stilling basin, indicating more area of the screen was being used to pass flow through the screen with the type 2 dewatering basin. Velocities were also measured across the dewatering basin at station 1 (5 in. (0.42 ft) above the screen) to evaluate the distribution of flow entering the dewatering basin. Velocities provided in Table 11 indicate that more flow occurs on the left half of the dewatering basin. The momentum resulting from the flow in the conduit bends would tend to cause flow at the outlet to move to the left side of the stilling basin. Velocities were also obtained with the pool lowered 1 ft to el 49. This was done to observe the effect of reducing the outlet submergence. Better energy dissipation occurred in the stilling basin but flows in the dewatering basin were not noticeably improved. The flow distribution with an inflow of 470 cfs and a water-level elevation in the basin of 50 was 57 cfs exiting the transport channel and 413 cfs discharging from the three outlet conduits. Flow conditions

¹ Long, D., Steffler, P. M., and Rajaratnam, N. (1990). "LDA study of flow structure in submerged hydraulic jump," *Journal of Hydraulic Research* 28(4), 437-460.

with the type 2 dewatering basin were improved over those with the type 1 design.

Type 1 design hood

A solid sloping roof was placed inside the stilling basin beginning at the top of the conduit and sloping upward to el 50 (32 ft downstream from the outlet). The desired effect of the hood was to eliminate the surface roller from the hydraulic jump. This was accomplished with a discharge of 470 cfs and a TW elevation of 50. Velocities were measured 5 in. above the screen at stations 2-6 to determine the effect of the hood on flow conditions in the dewatering basin with a discharge of 470 cfs and a TW elevation of 50. The hood prevented measurements from being obtained at station 1. Average, maximum, and minimum velocities obtained from these measurements are provided in Table 12. More area of the screen was used for passing flow through the screen and flow along the screen was distributed better between stations 4 and 6. These were considered improvements.

Type 3 design stilling basin

After discussions with the Charleston District concerning the performance of the type 4 AAF system with the type 2 dewatering basin and type 1 design hood, it was decided to lengthen the stilling basin and make other modifications to the basin. A 16-ft length of 48-in.-diam conduit was attached to the existing outlet conduits and the stilling basin was lengthened by 15.5 ft. The invert of the stilling basin at the new outlet was el 42 and then sloped downward on a 1V on 3H slope to el 41. The invert then sloped from el 41 to el 40 at 40.5 ft downstream from the outlet. These modifications, designated the type 3 design stilling basin, are shown in Plate 32. At the end of the stilling basin and entrance to the dewatering basin, the invert dropped 3 ft vertically to el 37 and then sloped downward to el 36 over a distance of 37 ft.

Velocities were measured in the dewatering basin to evaluate the flow distribution in the basin. The velocity stations relative to the dewatering basin and screen remained the same as shown in Plate 26. Velocities measured 5 in. above the screen at stations 1-7 are provided in Table 13. Distribution of the streamwise (x-direction) velocities was improved from those measured with the type 2 dewatering basin and type 1 hood as seen by comparing Tables 12 and 13. This indicates the flow entering the dewatering basin was more uniformly distributed than with the previous stilling basin. Velocities measured on the left side, center line, and right side of the dewatering basin at 0.42 (5 in.), 4.0, and 8.0 ft above the screen at station 1 are listed in Table 14. Time-histories of the x and z-components of velocity at station 1 (0.42 ft above the screen) are shown in Plate 33. Comparison of these with the velocities shown in Plate 30 for the type 2 dewatering basin indicate much less fluctuation in the flow and slower velocities, which would be more favorable for fish passage. Velocity profiles of the x-component at station 1 with the type 3 stilling basin are shown in Plate 34

and the velocity profiles for the z-component are shown in Plate 35. These measurements show the distribution of the x-component of velocity entering the dewatering basin is better with the type 3 stilling basin; however, the surface flow is less than the mid-depth and bottom flows, as indicated in Plate 34.

Center pipe discharge. The performance of the type 3 stilling basin was evaluated with only the center pipe discharging. The total inflow was 157 cfs and the tailwater elevation in the basin was 50. For these conditions, 27.3 cfs was diverted into the transportation channel. Velocities measured on the left side, center line, and right side of the dewatering basin at 0.42, 3.3, and 7.0 ft above the screen at station 1 are provided in Table 15. The flow in the dewatering basin with a discharge of 157 cfs was not distributed uniformly and varied with time. The velocity measurements listed in Table 15 indicate most of the flow in the dewatering basin occurred near the surface and especially along the right side of the basin. Depthwise flow (z-component of velocity) near the screen at the station 1 flume was low, less than 0.3 ft/sec, and towards the surface. Due to flow reversals and concentrations, the flow conditions in the dewatering basin with a center pipe discharge of 157 cfs and a tailwater elevation of 50 were not as favorable for fish passage as those with three pipes discharging.

Outside pipes discharging. The performance of the type 3 stilling basin was evaluated with the center pipe closed and the outside pipes discharging. The total inflow was 314 cfs, 157 cfs from each pipe, and the tailwater elevation in the basin was 50. For these conditions, 34 cfs was diverted into the transportation channel. Velocities measured on the left side, center line, and right side of the dewatering basin at 0.42, 3.3, and 7.0 ft above the screen at station 1 are provided in Table 16. As observed with the center pipe discharge, the flow in the dewatering basin with a discharge of 314 cfs was not distributed uniformly and varied with time. The velocity measurements listed in Table 16 indicate most of the flow in the dewatering basin occurred on the sides of the basin. The largest depthwise velocity (z-component of velocity) near the screen at the station 1 flume occurred at the center line of the basin and was 0.4 ft/sec towards the surface. The flow conditions in the dewatering basin were not as favorable as those with three pipes discharging, but were considered acceptable for fish passage.

Type 2 hood. A hood was placed over the stilling basin as shown in Plate 32 and Figure 6. The desired effect of the hood was to eliminate the surface roller from the hydraulic jump. Velocity measurements were obtained at station 1 to compare the flow distribution with the hood in place to the distribution of flow without the hood in place (Table 14). These measurements were made on the left side, center, and right side of the basin at depths of 0.42, 3.3, and 7.0 ft above the screen at station 1 and are provided in Table 17. The flow conditions were improved at station 1 with the hood in place. Velocities measured along the left side were slightly higher and those measured along the right side were slightly lower than those measured without the hood. The hood improved the depthwise distribution of flow entering the dewatering basin and fluctuations in flow were reduced with the hood in place. Velocity profiles of the x- component



Figure 6. Side view of hood, stilling basin, and dewatering basin for the type 4 AAF design

at station 1 are shown in Plate 34 for the type 3 stilling basin with and without the hood. Velocity profiles of the z- component at station 1 are shown in Plate 35 for the type 3 stilling basin with and without the hood. Time-histories of the x- and z-components at station 1 (0.42 ft above the screen) are shown in Plate 36. The time-histories indicate the flow is predominantly in the downstream direction and the velocity fluctuations are not extreme. Comparison of these velocities with those measured without the hood indicate the flow conditions in the dewatering basin were improved with the type 2 hood in place. Average velocities for the x and z components were also obtained along the center line and 5 ft right and left (looking downstream) of the center line at the bottom, middepth, and surface throughout the dewatering basin. Average velocities obtained 5 in. (0.42 ft) above the screen are shown in Plate 37. The velocities indicate most of the flow passes through the screen in a downstream direction. The depthwise component of the flow (the z-component) is small compared to the streamwise component (x-component). The majority of the velocities measured in the depthwise direction near the screen were around 0.1 ft/sec. Average velocities obtained at middepth and at depth surface are shown in Plates 38 and 39, respectively.

With a total inflow of 470 cfs and the outlet pipes set to provide a water-surface elevation of 50 in the dewatering basin, 34 cfs discharged through the transportation channel and 436 cfs discharged through the outlet conduits for the auxiliary attraction flow. The transportation flow was approximately 7 percent of the total inflow and this was the amount desired. Additional velocities were then obtained with the center and outside pipe discharge conditions.

Type 2 hood, center pipe discharge. Performance of the type 3 stilling basin and type 2 hood was evaluated with only the center pipe discharging. The total inflow was 157 cfs and the tailwater elevation in the basin was 50. Velocities measured on the left side, center line, and right side of the dewatering basin at 0.42, 3.3, and 7.0 ft above the screen at station 1 are provided in Table 18. The velocity measurements indicate most of the flow in the dewatering basin occurred along the right side of the basin and the flow near the center and left side was actually in the upstream direction. This type flow reversal is not desired for fish passage. Average depthwise velocities (z-component of velocity) near the screen at station 1 were generally higher than those measured without the hood. With a total inflow of 157 cfs and the outlet pipes set to provide a water-surface elevation of 50 in the dewatering basin, 29 cfs discharged through the transportation channel and 128 cfs discharged through the outlet conduits for the auxiliary attraction flow. The difference in the transportation flow between three inflow pipes discharging into the stilling basin and one pipe discharging into the stilling basin is due to the difference in the flow approaching the weir. The flow approaching the weir is much more tranquil with only one pipe discharging.

Type 2 hood, outside pipes discharging. Performance of the type 3 stilling basin and type 2 hood was also evaluated with the center pipe closed and the outside pipes discharging. The total inflow was 314 cfs (157 cfs from each pipe) and the tailwater elevation in the basin was 50. Velocities measured on the left

side, center line, and right side of the dewatering basin at 0.42, 3.3, and 7.0 ft above the screen at station 1 are provided in Table 19. As observed without the hood, more flow entered the dewatering basin on the left side with a discharge of 314 cfs. The flow was distributed more uniformly in the streamwise direction with the hood in the basin. The flow conditions in the dewatering basin were improved with the hood in place and the outside pipes discharging compared to the conditions without the hood. These flow conditions with the outside pipes discharging 314 cfs and a tailwater elevation of 50 were considered acceptable for fish passage. With a total inflow of 313 cfs and the outlet pipes set to provide a water-surface elevation of 50 in the dewatering basin, 31 cfs discharged through the transportation channel and 282 cfs discharged through the outlet conduits for the auxiliary attraction flow.

4 Summary, Conclusions, and Recommendations

Summary

Numerous experiments were conducted to evaluate the flow conditions in the AAF facility proposed for the St. Stephen Powerhouse Project. Ultimate goals of the design were to provide additional attraction flow discharge for the existing upstream fish migration facility and also provide a functional fish passage facility for downstream migrants and one that would also pass debris through to the tailrace with minimal maintenance requirements. Adequate performance of a facility for all these goals is quite difficult to achieve.

The first two concepts, the types 1 and 2 AAF designs, with a single- and double-conduit siphon system, a stilling pool discharge area, and a large vertical trash screen for debris passage did not include any provisions for downstream fish migration. The purpose of these designs was to provide auxiliary attraction flow for the existing fish passage system and introduce this additional flow into the existing fish channels in a manner which did not adversely affect the movement of the fish towards the lift system. The type 2 AAF system accomplished these functions; however, the removal of debris, especially floating vegetative material, was anticipated to be a problem. The stilling pool discharge area and the trash screen features of the type 2 AAF design were eliminated when passage of downstream migrants was included as a design function.

The concept of passing fish and debris through the siphon system introduced the need to dewater at the discharge end of the siphon so the fish and debris could be transported to the desired location in the tailrace. Most of the discharge was still required for auxiliary attraction flows, but a portion was needed to transport the fish and debris. Submerged screens became part of this dewatering design and were necessary to guide the fish and debris to the transportation channel. Velocities in the dewatering basin of the type 3 AAF design were too high for safe fish passage and the siphon outlet was too low to function as desired. The siphon outlet was raised in the type 4 AAF design and the velocities in the dewatering basin were reduced to an acceptable level. The stilling basin and dewatering basin of the original type 4 AAF design were modified to achieve the desired performance. Final design of the type 4 AAF system

consisted of a siphon with three 36.9-in. inside diameter conduits attached to three 16-ft-long, 48-in.-diam pipes at the outlet. These pipes discharged into a stilling basin 16 ft wide at the pipe outlet and 20 ft wide 40.5 ft downstream from the outlet (a 37-ft-long by 20-ft-wide dewatering basin with a sloping screen beginning at el 40 and ending at el 49.4). The bottom of the dewatering basin was offset 3 ft at the end of the stilling basin and from this elevation of 37 sloped to el 36 at the end of the basin. The transportation channel was located on the surface at the end of the dewatering basin on the right side. The auxiliary attraction flow was carried to the tailrace with three 36-in.-diam pipes located at the end of the dewatering basin on the floor of the basin. Details of the recommended type 4 AAF design are shown in Plate 32. With a total inflow of 470 cfs discharging from the three inflow pipes, approximately 7 percent of this flow was diverted into the transportation channel with a water-surface elevation of 50 in the dewatering basin.

Conclusions and Recommendations

The experiments to develop the outlet for the AAF system for the St. Stephen Powerhouse indicated acceptable hydraulic performance could be achieved using a combination conduit siphon system with stilling and dewatering basins. The design developed performed the best with a solid sloping hood placed over the stilling basin section and the three conduits operating with equal discharges of 157 cfs and a tailwater elevation in the basins of 50. Average streamwise velocities entering the dewatering basin for these conditions ranged from 1.0 to 4.5 ft/sec with the higher velocities measured along the left side of the basin. The velocities are higher on this side due to the curve in the siphon conduits upstream from the discharge outlet. Average streamwise velocities in the dewatering basin near the screen were generally between 2 and 3 ft/sec with three pipes discharging. Generally, average depthwise velocities between 0.1 and 0.2 ft/sec should be expected near the screen with three pipes discharging. With all three pipes discharging, flow is drawn from underneath the screen near the upstream portion in the dewatering basin and most of the flow through the screen occurs in the downstream two thirds to three quarters of the screen. The component of flow perpendicular to the screen is small compared to the horizontal or downstream component of flow through the screen. This distribution of flow through the screen should provide acceptable conditions for fish passage, but could probably be improved by redistributing the porosity through the screen. This would not be a difficult task to perform once the facility is constructed. Performance of the type 4 AAF design with one or two pipes discharging into the stilling basin was not as good as with all three pipes discharging equally. Flow reversals, concentrations, and fluctuations were more noticeable than those observed with the three pipes operating equally. This will probably affect the fish passage characteristics of the system, although a detrimental effect is not expected. To achieve lower discharges, it is recommended that all three inflow pipes are operated equally at lower flow rates rather than operations with one pipe.

Performance of the fish passage facility should be further evaluated once the facility is constructed. Valuable operating guidance could be obtained and possible improvements to hydraulic performance could be achieved by evaluation of porosity plates placed in various locations underneath the screen. It is recommended that the three discharge pipes be operated with similar discharges, if possible, to reduce flow concentrations and fluctuations in the stilling basin and the dewatering basin. The screening system should also incorporate methods to easily clean and maintain it. The screen might be designed to pivot so it could be washed and cleaned more easily.

Table 1
Type 1 Design AAF System, Water-Surface Elevations,
Powerhouse Discharge 21,300 cfs, Tailwater EI 26.0

Water-Surface Station	MAF ¹ 500 cfs AAF ² 500 cfs	MAF 0 cfs AAF 500 cfs	MAF 250 cfs AAF 250 cfs
A	³	³	³
B	29.6	28.6	26.8
C	28.1	26.7	26.0
D	28.1	26.2	25.0
E	27.5	26.0	25.9
F	27.5	25.9	25.9
G	27.6	26.0	26.1
H	26.1	25.3	25.4
I	25.3	25.3	26.1

¹ MAF = Main attraction flow.
² AAF = Auxiliary attraction flow.
³ Water too choppy for surface measurement.

Table 2
Type 1 Design AAF System, Port Velocities, Powerhouse
Discharge 21,300 cfs, Tailwater EI 26.0

Port No.	MAF 500 cfs AAF 500 cfs	MAF 0 cfs AAF 500 cfs	MAF 250 cfs AAF 250 cfs
1	5.9	6.2	3.6
2	5.9	5.6	2.3
3	5.3	5.0	2.5
4	4.9	3.6	1.9
5	4.4	3.0	1.6
6	3.5	2.9	1.4
7	3.7	3.2	1.5
8	2.4	2.3	0.8
9	1.4	1.3	1.0
10	1.3	0.9	0.8

Note: Velocities measured at center of port 0.75 ft off the floor.

Table 3 Type 2 Design AAF System, Water-Surface Elevations			
Water-Surface Station	TW¹ EL 26.0 PHF² 21,300 cfs MAF³ 150 cfs AAF⁴ 500 cfs	TW EL 12.0 Phf 7,100 cfs MAF 150 cfs AAF 500 cfs	TW EL 16.6 PHF 7,100 cfs MAF 150 cfs AAF 500 cfs
A	4	4	4
B	28.9	26.7	26.6
C	27.1	15.1	16.9
D	26.5	14.9	16.4
E	26.2	14.6	16.1
F	26.1	14.0	15.7
G	26.4	13.5	15.6
H	25.3	10.9	14.9
I	24.9	10.1	14.6
¹ PHF = Powerhouse flow. ² MAF = Main attraction flow. ³ AAF = Auxiliary attraction flow. ⁴ Water too choppy for surface measurement.			

Table 4 Type 2 Design AAF System, Type 2 Floor Grate, Type 2 Ported Channel Design, PHF¹ 21,300 cfs, MAF³ 150 cfs, AAF³ 500 cfs, Tallwater EL 26.0	
Water-Surface Station	Water-Surface Elevations
A	4
B	28.5
C	27.1
D	26.4
E	26.3
F	26.1
G	26.3
H	25.1
I	24.8
¹ PHF = Powerhouse flow. ² MAF = Main attraction flow. ³ AAF = Auxiliary attraction flow. ⁴ Water too choppy for surface measurement.	

Table 5 Type 2 Design AAF System, Type 2 Ported Channel Design, Type 4 Floor Grate, MAF¹ 150 cfs, AAF² 500 cfs, Water-Surface Elevations				
Water-Surface Station	TW EL 26.0 PHF³ 21,300 cfs	TW EL 23.1 PHF 21,300 cfs	TW EL 20.9 PHF 14,200 cfs	TW EL 16.6 PHF 7,100 cfs
A	4	4	4	4
B	28.5	27.5	27.5	27.5
C	27.1	24.1	22.3	18.3
D	26.4	23.5	21.7	17.9
E	26.3	23.3	21.5	17.6
F	26.1	23.1	21.3	17.2
G	26.3	23.2	21.4	17.2
H	25.1	22.3	20.4	15.9
I	24.8	22.1	19.9	15.6

¹ MAF = Main attraction flow.
² AAF = Auxiliary attraction flow.
³ PHF = Powerhouse flow.
⁴ Water too choppy for surface measurement.

Table 6 Type 2 Auxiliary Attraction Flow System, Type 2 Ported Channel Design, Type 4 Floor Grate, Fish Channel Weir Elevations			
Powerhouse Discharge, cfs	TW EL	Fish Channel Weir Elevation	
		Upstream	Downstream
21,300	26.0	16.0	21.0
21,300	23.1	13.0	18.0
14,200	20.9	11.0	16.0
7,100	16.6	6.5 ¹	11.0

¹ Porous from EL 6.5 to EL 11.0.

Table 7 Velocities, Type 4 AAF System, Discharge 470 cfs, TW EL 50, Type 1 Stilling Basin						
Station	X Comp of Velocity in ft/sec			Z Comp of Velocity in ft/sec		
	Average	Max	Min	Average	Max	Min
1	10.3	18.5	0.0	1.9	4.0	-1.1
2	3.0	12.0	-2.0	1.7	5.0	-2.0
3	2.0	8.0	-1.5	1.2	3.0	-1.5
4	3.1	7.0	0.0	-0.1	2.6	-2.0
5	5.0	7.8	1.0	-0.1	2.0	-1.5
6	5.9	9.0	3.0	-0.1	1.8	-2.2

Note: Velocities were measured 5 in. above screen at designated stations.

Table 8 Velocities, Type 4 AAF System, Type 1 Stilling Basin, Station 1, Discharge 470 cfs, TW EL 50						
Dist. Above Screen, ft	X Comp of Velocity in ft/sec			Z Comp of Velocity in ft/sec		
	Average	Max	Min	Average	Max	Min
0.42	10.3	18.5	0.0	1.9	4.0	-1.1
4	8.5	12.5	-2.5	1.9	5.0	-0.3
6	2.0	11.0	-6.0	2.5	7.0	-1.0

Table 9 Velocities, Type 4 AAF System, Discharge 470 cfs, TW EL 50, Type 2 Dewatering Basin						
Station	X Comp of Velocity in ft/sec			Z Comp of Velocity in ft/sec		
	Average	Max	Min	Average	Max	Min
1	10.3	18.8	0.5	1.8	3.5	0.0
2	3.0	8.0	-4.0	0.1	2.8	-2.0
3	4.0	8.2	-2.4	-0.1	2.2	-2.1
4	4.0	8.0	-0.2	-0.2	2.0	-2.1
5	5.5	9.5	3.0	-0.1	1.7	-1.5
6	6.1	8.2	3.0	0.2	1.3	-0.8

Note: Velocities were measured 5 in. above screen at designated stations.

Table 10 Velocities, Type 4 AAF System, Type 2 Dewatering Basin, Station 1, Discharge 470 cfs, TW EL 50						
Dist. Above Screen, ft	X Comp of Velocity in ft/sec			Z Comp of Velocity in ft/sec		
	Average	Max	Min	Average	Max	Min
0.42	10.3	18.8	0.5	1.8	3.5	0.0
4	8.0	16.0	-4.0	1.3	5.0	-2.0
6	4.0	13.0	-4.0	1.8	5.9	-1.8

Table 11 Velocities, Type 4 AAF System, Discharge 470 cfs, Type 2 Dewatering Basin, Station 1, 5 in. Above Screen						
TW EL 50						
Cross Stream Location	X Comp of Velocity in ft/sec			Z Comp of Velocity in ft/sec		
	Average	Max	Min	Average	Max	Min
LS	8.0	17.5	1.5	1.0	3.2	-1.8
C-L	10.3	18.8	0.5	1.8	3.5	0.0
RS	2.5	9.0	-4.0	0.9	3.0	-1.3
TW EL 49						
LS	11.0	18.0	5.0	0.7	3.0	-1.0
C-L	8.0	17.5	0.5	1.5	3.8	-0.5
RS	3.0	10.0	-2.5	0.8	3.5	-1.3

Table 12 Velocities, Type 4 AAF System, Discharge 470 cfs, TW EL 50, Type 2 Dewatering Basin, Type 1 Design Hood						
Station	X Comp of Velocity in ft/sec			Z Comp of Velocity in ft/sec		
	Average	Max	Min	Average	Max	Min
2	3.5	8.0	0.2	0.3	2.8	-1.5
3	3.7	7.0	0.7	-0.3	1.8	-2.0
4	4.5	7.7	2.5	-0.2	1.7	-1.7
5	5.1	7.6	3.0	-0.1	1.7	-1.7
6	5.5	7.5	3.5	-0.1	1.9	-2.0

Note: Velocities were measured 5 in. above screen at designated stations.

Table 13
Velocities, Type 4 AAF System, Discharge 470 cfs, TW EL 50,
Type 3 Stilling Basin

Station	X Comp of Velocity in ft/sec			Z Comp of Velocity in ft/sec		
	Average	Max	Min	Average	Max	Min
1	3.7	7.0	1.0	0.2	1.5	-1.0
2	3.3	5.8	0.1	0.2	1.5	-0.8
3	2.7	4.0	1.5	0.0	1.2	-0.5
4	3.1	5.0	2.0	-0.1	1.5	-1.0
5	2.5	4.0	0.5	-0.1	0.8	-0.8
6	2.7	4.0	2.0	-0.1	0.8	-1.0
7	2.0	4.0	0.5	-0.2	0.8	-1.0

Note: Velocities were measured 5 in. above screen at designated stations.

Table 14
Velocities, Type 4 AAF System, Discharge 470 cfs, TW EL 50,
Type 3 Stilling Basin, Station 1

Cross Stream Location	Dist. Above Screen, ft	X Comp of Velocity in ft/sec			Z Comp of Velocity in ft/sec		
		Average	Max	Min	Average	Max	Min
LS	0.42	4.5	6.0	3.2	0.0	1.0	-1.0
LS	4.0	3.0	5.0	0.0	0.2	2.2	-1.5
LS	8.0	1.0	2.5	-1.0	-0.1	1.7	-1.5
CL	0.42	3.7	7.0	1.0	0.2	1.5	-1.0
CL	4.0	3.0	6.0	0.0	-0.1	2.0	-2.0
CL	8.0	-0.5	1.5	-1.5	-0.4	1.5	-1.5
RS	0.42	3.6	6.0	2.0	0.1	1.2	-0.5
RS	4.0	3.5	5.0	0.5	0.5	2.0	-1.2
RS	8.0	1.8	3.5	0.0	0.4	1.5	-1.5

Table 15
Velocities, Type 4 AAF System, Discharge 157 cfs (Center Pipe Only) TW EL 50, Type 3 Stilling Basin, Station 1

Cross Stream Location	Dist. Above Screen, ft	X Comp of Velocity in ft/sec			Z Comp of Velocity in ft/sec		
		Average	Max	Min	Average	Max	Min
LS	0.42	0.0	3.8	-3.5	0.0	1.5	-1.0
LS	3.3	1.0	3.5	-1.5	0.0	1.5	-1.0
LS	7.0	1.0	4.0	-1.2	-0.2	1.0	-2.0
CL	0.42	0.0	1.5	-1.0	-0.1	1.0	-0.5
CL	3.3	1.0	2.5	-0.5	0.3	1.5	-0.8
CL	7.0	1.3	4.0	-1.0	-0.1	1.7	-1.5
RS	0.42	0.5	3.5	-0.5	0.3	0.8	-0.5
RS	3.3	-0.5	1.0	-1.0	0.3	1.0	-0.5
RS	7.0	2.7	3.5	1.3	0.0	1.5	-1.5

Table 16
Velocities, Type 4 AAF System, Discharge 314 cfs (Outside Pipes Only) TW EL 50, Type 3 Stilling Basin, Station 1

Cross Stream Location	Dist. Above Screen, ft	X Comp of Velocity in ft/sec			Z Comp of Velocity in ft/sec		
		Average	Max	Min	Average	Max	Min
LS	0.42	3.7	8.0	0.0	-0.1	2.1	-1.8
LS	3.3	3.0	6.5	0.0	-0.1	3.3	-2.0
LS	7.0	-0.1	3.1	-2.3	-0.3	2.1	-2.1
CL	0.42	0.7	2.0	-1.5	0.4	1.8	-0.5
CL	3.3	0.0	2.0	-1.7	0.3	2.0	-1.5
CL	7.0	0.1	2.5	-2.0	0.2	2.4	-2.2
RS	0.42	0.7	3.1	-1.5	0.3	1.5	-1.7
RS	3.3	1.8	4.5	-0.5	0.3	3.3	-2.0
RS	7.0	2.5	5.5	-0.5	0.3	3.0	-1.8

Table 17
Velocities, Type 4 AAF System, Discharge 470 cfs, TW EL 50,
Type 3 Stilling Basin, Type 2 Hood, Station 1

Cross Stream Location	Dist. Above Screen, ft	X Comp of Velocity in ft/sec			Z Comp of Velocity in ft/sec		
		Average	Max	Min	Average	Max	Min
LS	0.42	4.5	6.7	2.0	0.1	1.3	-1.0
LS	3.3	3.8	5.5	1.5	0.2	1.8	-1.2
LS	7.0	2.7	5.0	0.5	0.1	1.7	-1.5
CL	0.42	3.5	5.8	1.0	0.1	1.2	-0.8
CL	3.3	2.7	5.0	0.5	0.1	2.0	-1.5
CL	7.0	1.0	3.5	-1.2	-0.2	1.8	-1.8
RS	0.42	2.6	5.2	0.7	0.1	1.5	-1.0
RS	3.3	2.2	3.7	0.3	-0.1	1.4	-1.6
RS	7.0	1.3	2.7	-0.3	-0.1	1.7	-1.5

Table 18
Velocities, Type 4 AAF System, Discharge 157 cfs (Center Pipe
Only) TW EL 50, Type 3 Stilling Basin, Type 2 Hood, Station 1

Cross Stream Location	Dist. Above Screen, ft	X Comp of Velocity in ft/sec			Z Comp of Velocity in ft/sec		
		Average	Max	Min	Average	Max	Min
LS	0.42	-1.3	1.0	-4.0	0.8	1.4	0.4
LS	3.3	-1.7	-0.7	-2.5	0.5	1.5	-0.5
LS	7.0	-1.4	-0.5	-2.3	0.5	1.8	-0.6
CL	0.42	-0.3	3.5	-3.8	0.8	1.7	-0.4
CL	3.3	-0.2	2.5	-2.0	0.6	3.0	-2.0
CL	7.0	-0.6	1.3	-2.0	-0.2	2.3	-2.0
RS	0.42	2.4	6.3	-2.0	0.4	1.7	-1.2
RS	3.3	3.1	6.5	0.0	0.1	3.4	-2.0
RS	7.0	2.7	5.2	0.5	-0.1	2.0	-2.0

Table 19
Velocities, Type 4 AAF System, Discharge 314 cfs (Outside Pipes Only) TW EL 50, Type 3 Stilling Basin, Type 2 Hood, Station 1

Cross Stream Location	Dist. Above Screen, ft	X Comp of Velocity in ft/sec			Z Comp of Velocity in ft/sec		
		Average	Max	Min	Average	Max	Min
LS	0.42	2.8	7.7	0.0	-0.1	2.0	-2.8
LS	3.3	3.3	7.5	-0.5	0.1	4.0	-3.5
LS	7.0	1.5	4.3	-1.5	0.1	2.3	-1.5
CL	0.42	1	3.7	-1.8	0.2	2.0	-1.5
CL	3.3	1.5	5.0	-1.3	0.0	2.5	-2.0
CL	7.0	0.3	2.2	-1.0	0.0	1.8	-1.7
RS	0.42	0.3	3.3	-1.5	-0.1	1.3	-1.3
RS	3.3	1.8	4.7	-0.8	0.3	2.3	-1.6
RS	7.0	1.7	5.7	-1.5	-0.1	2.5	-2.3

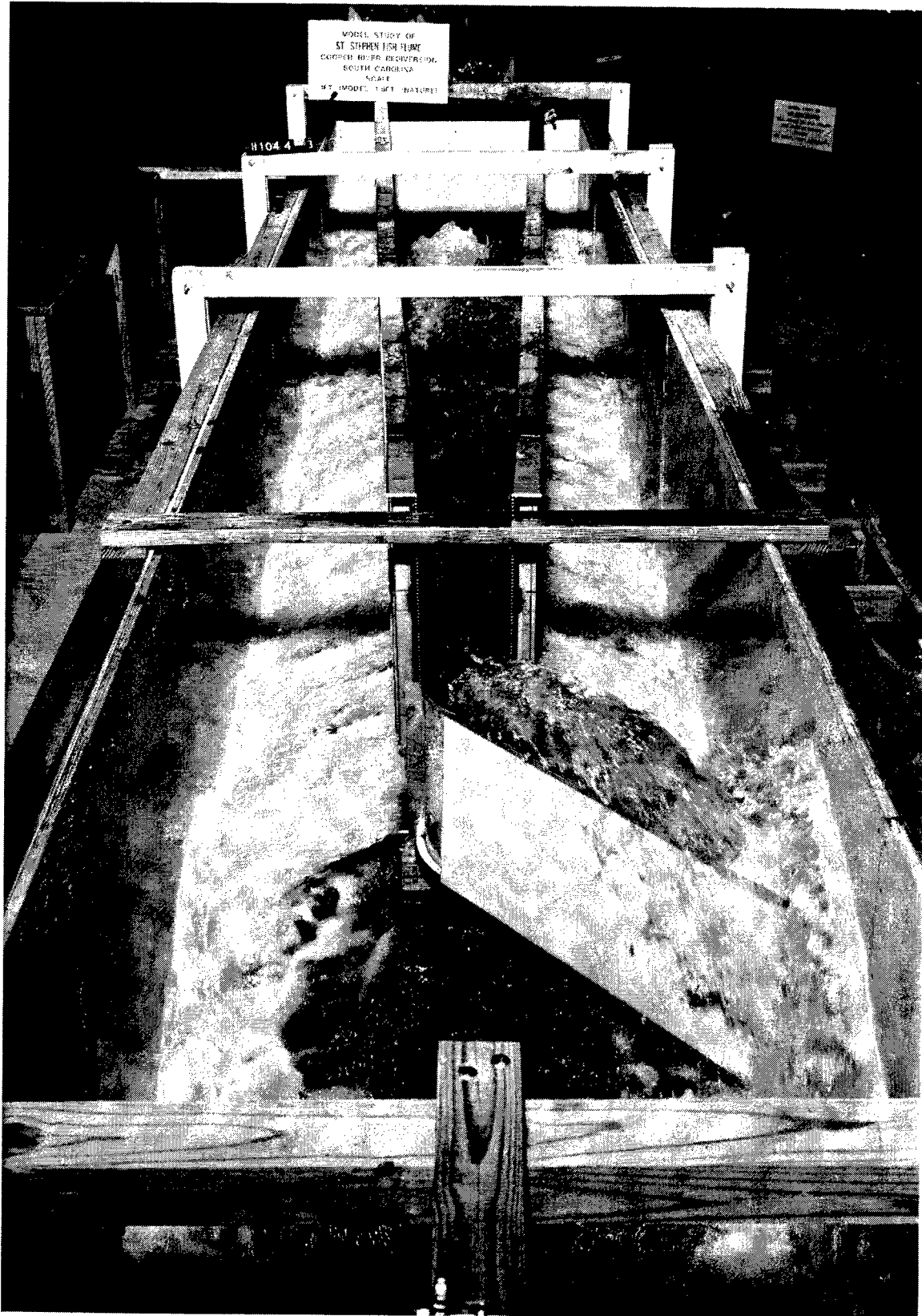

Photo 1. Flow conditions in the fish flume with the type 3 design AAF system and discharge of 600 cfs

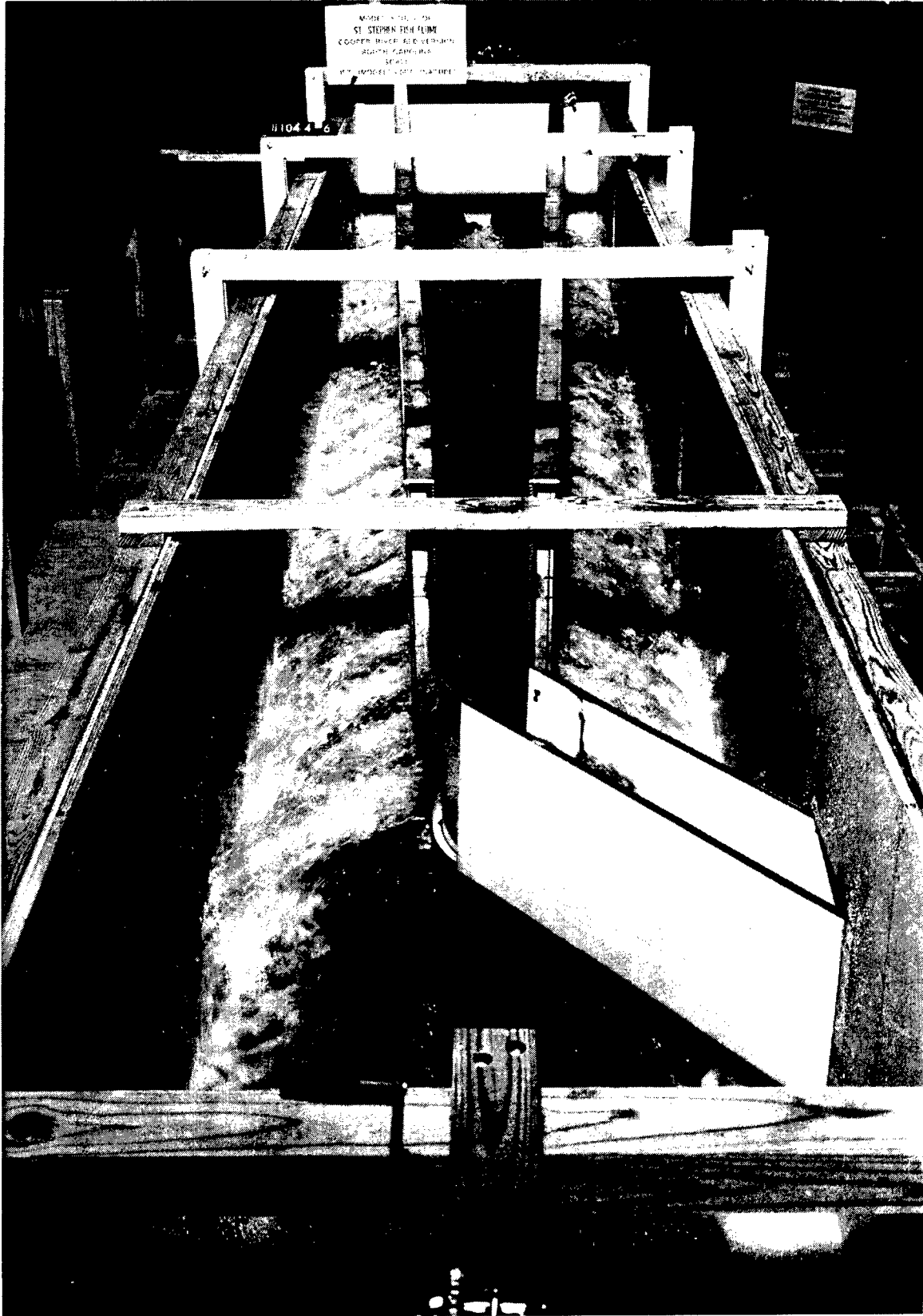

Photo 2. Flow conditions in the fish flume with the type 3 design AAF system and discharge of 400 cfs

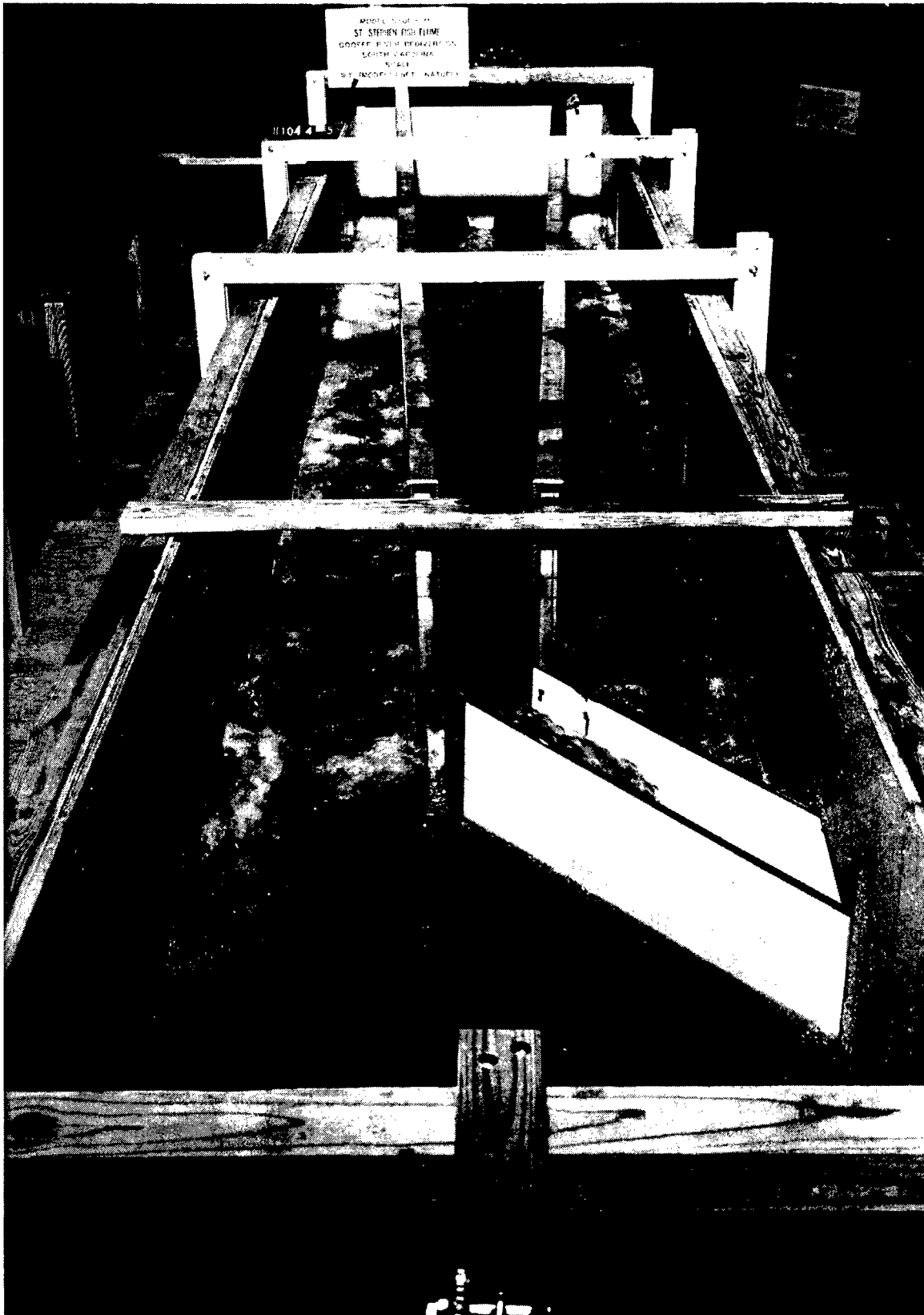
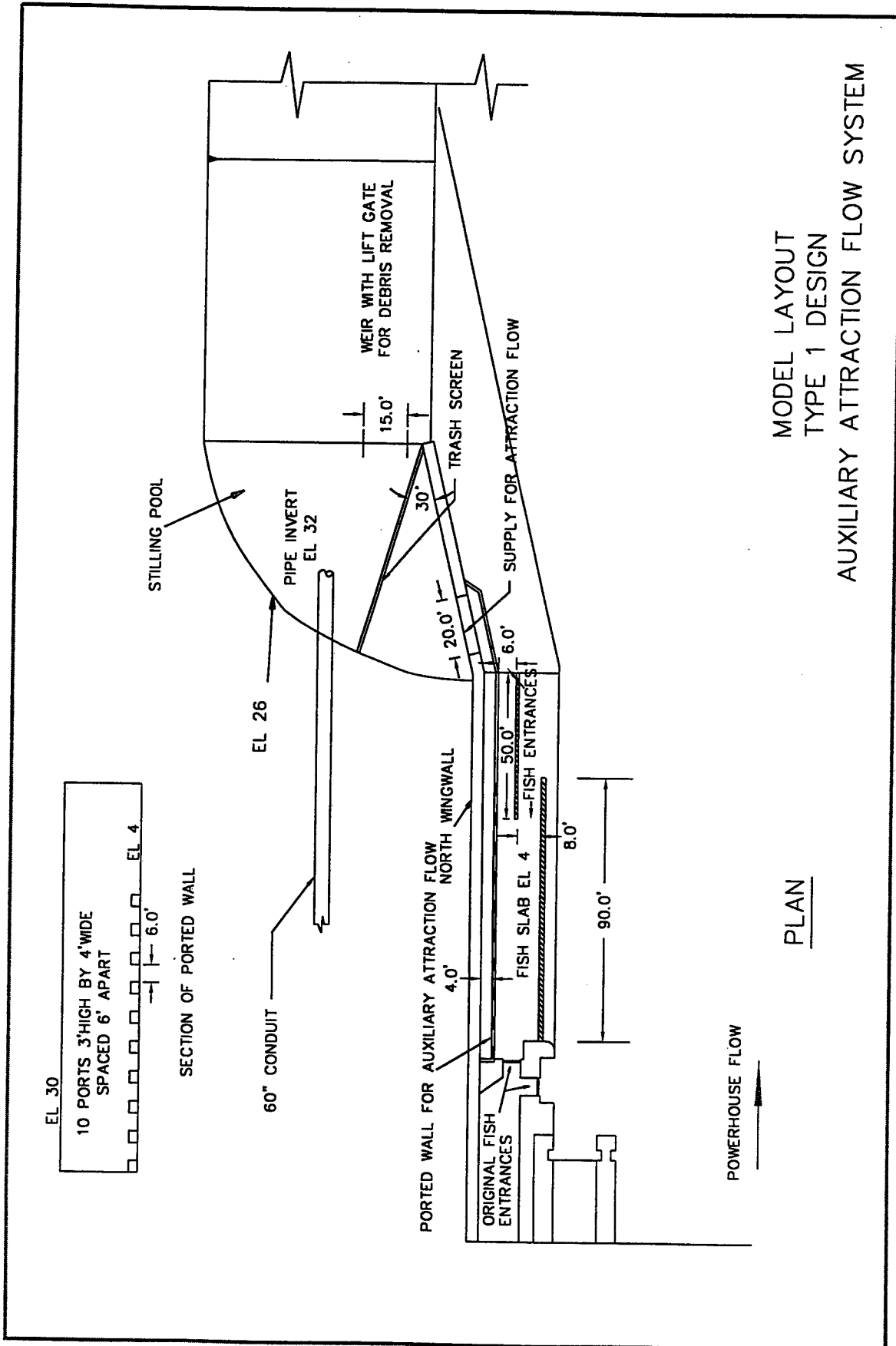

Photo 4. Flow conditions in the fish flume with the type 3 design AAF system, a discharge of 400 cfs, and a tailwater el of 33.0

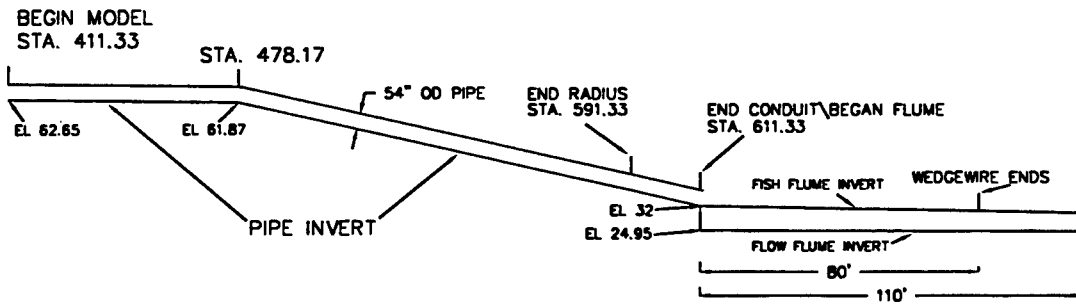
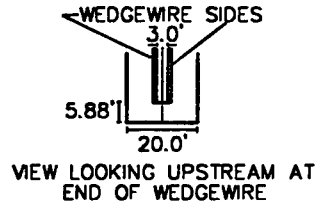
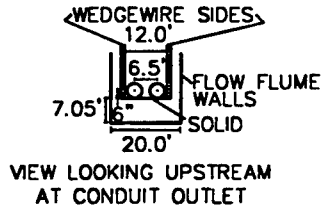
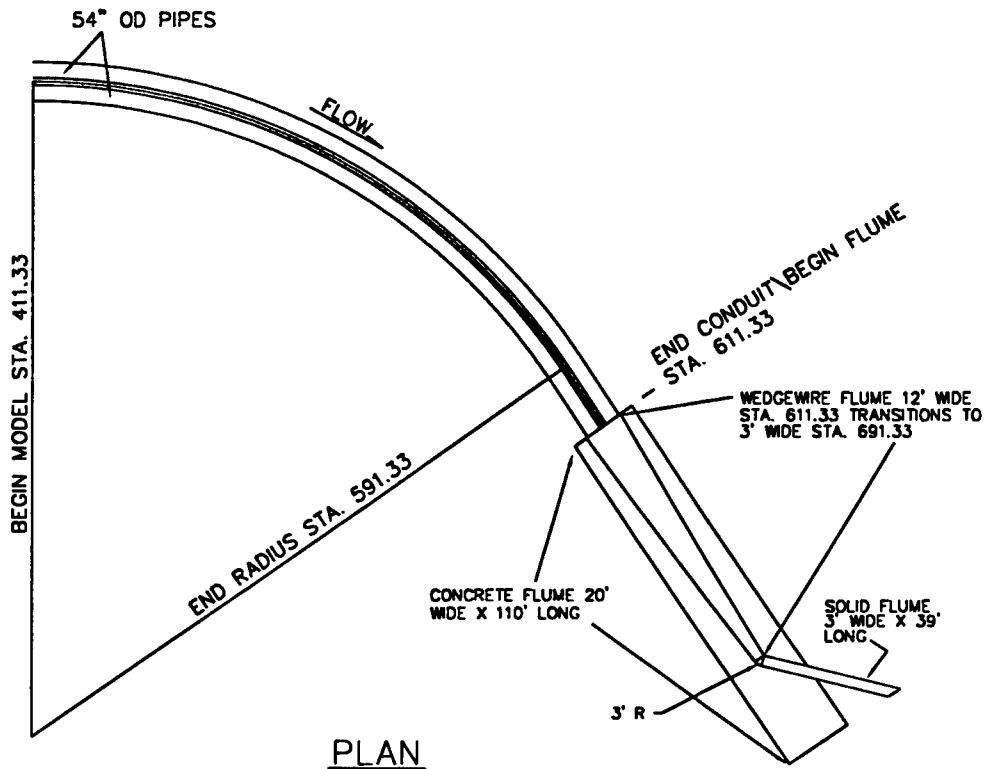

Photo 5. Hydraulic jump in fish channel the type 3 design AAF system, type 7 design fish flume, discharge of 600 cfs, and tailwater el of 33.0



MODEL LAYOUT
 TYPE 1 DESIGN
 AUXILIARY ATTRACTION FLOW SYSTEM

PLAN



PROFILE

FISH FLUME INVERT SLOPE= 0.017
 FLOW FLUME INVERT SLOPE= 0.0023

MODEL LAYOUT
 TYPE 3 DESIGN AAF SYSTEM

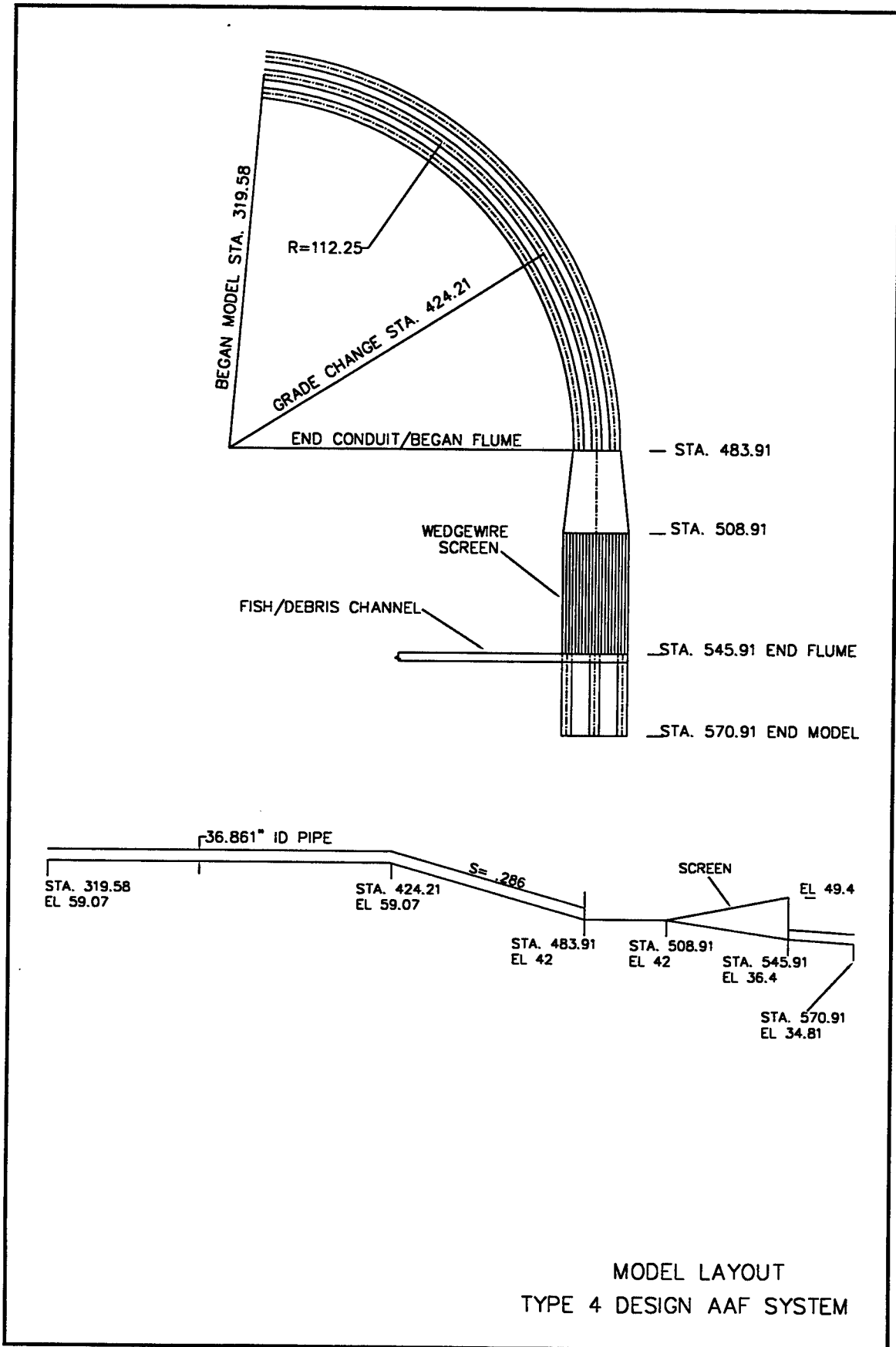

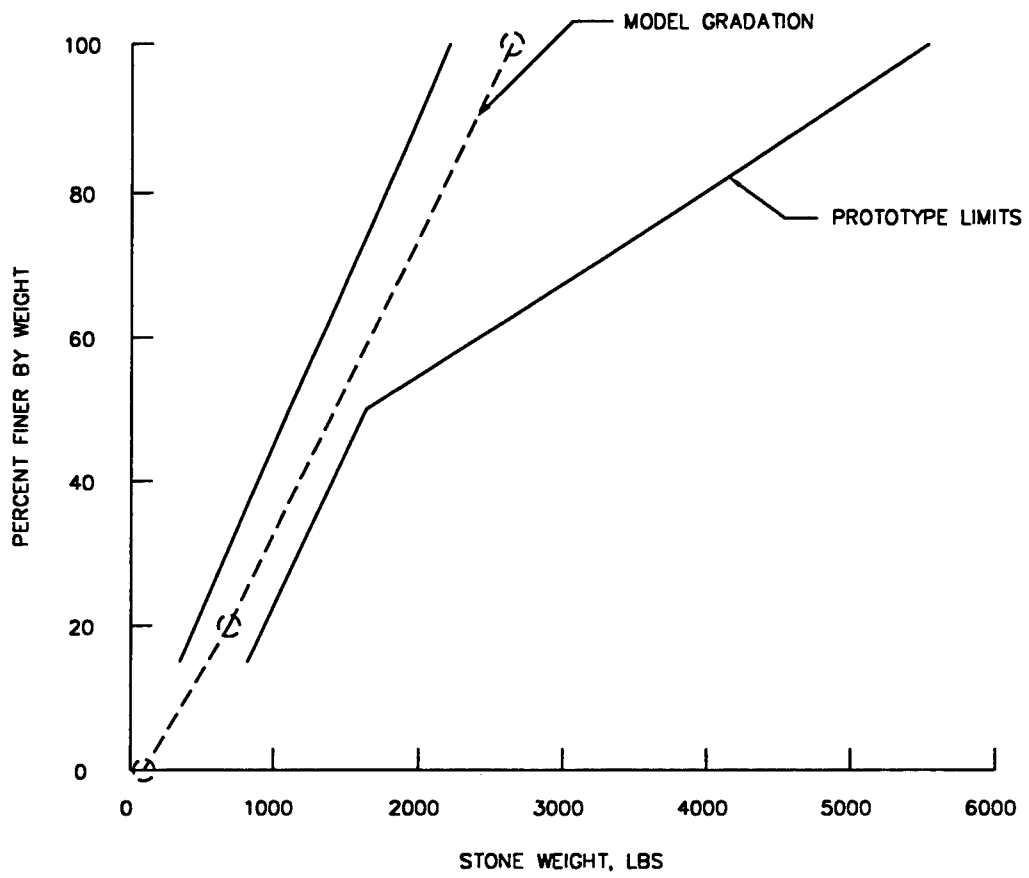

TYPE 1 DESIGN AAF SYSTEM
 TYPE 1 DESIGN RIPRAP GRADATION
 $D_{50} = 30$ IN.
 BLANKET THICKNESS = 72 IN.

Plate 4

WATER-SURFACE STATIONS
AND VELOCITY RANGES
TYPE 1 AAF SYSTEM

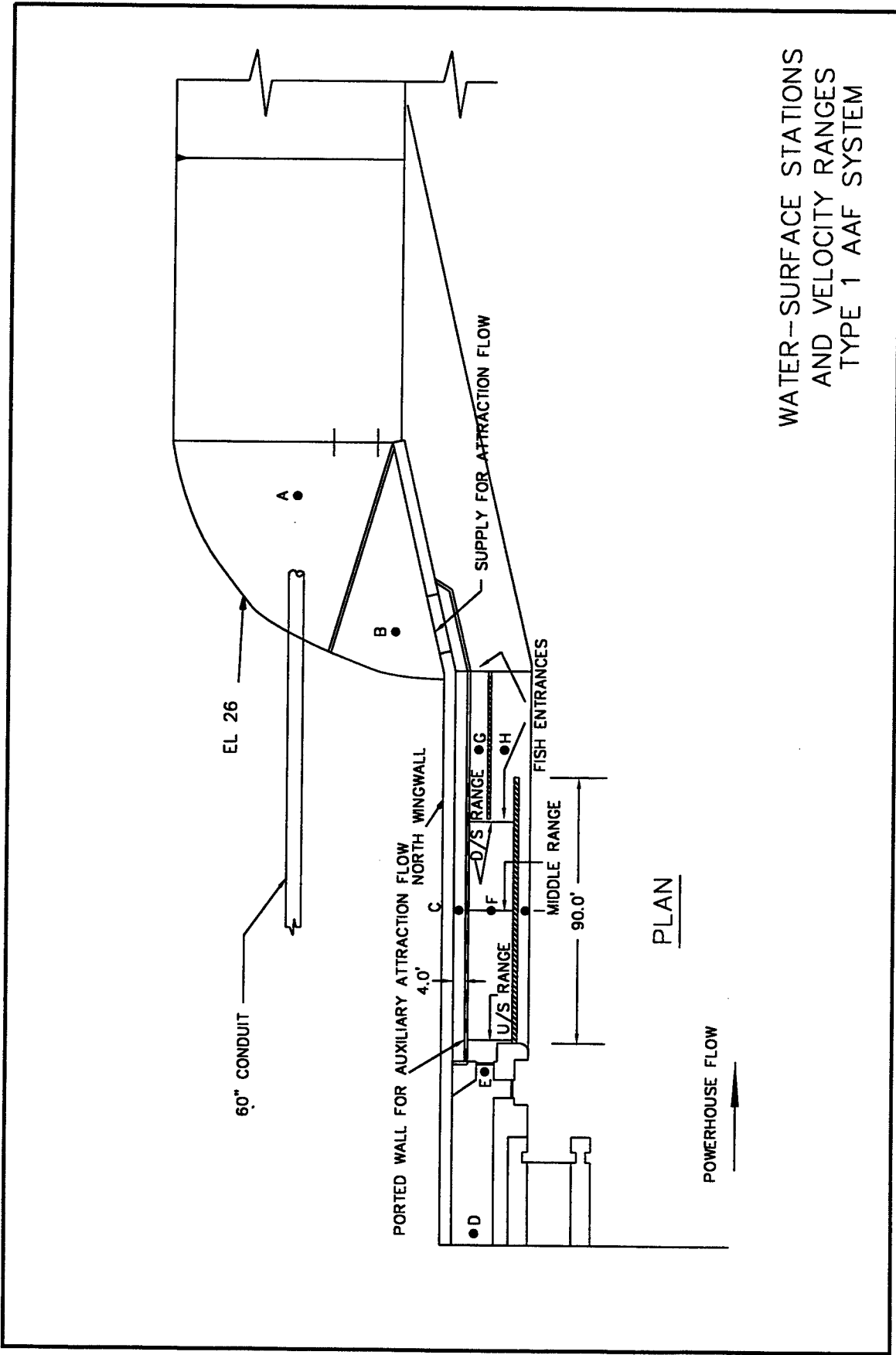

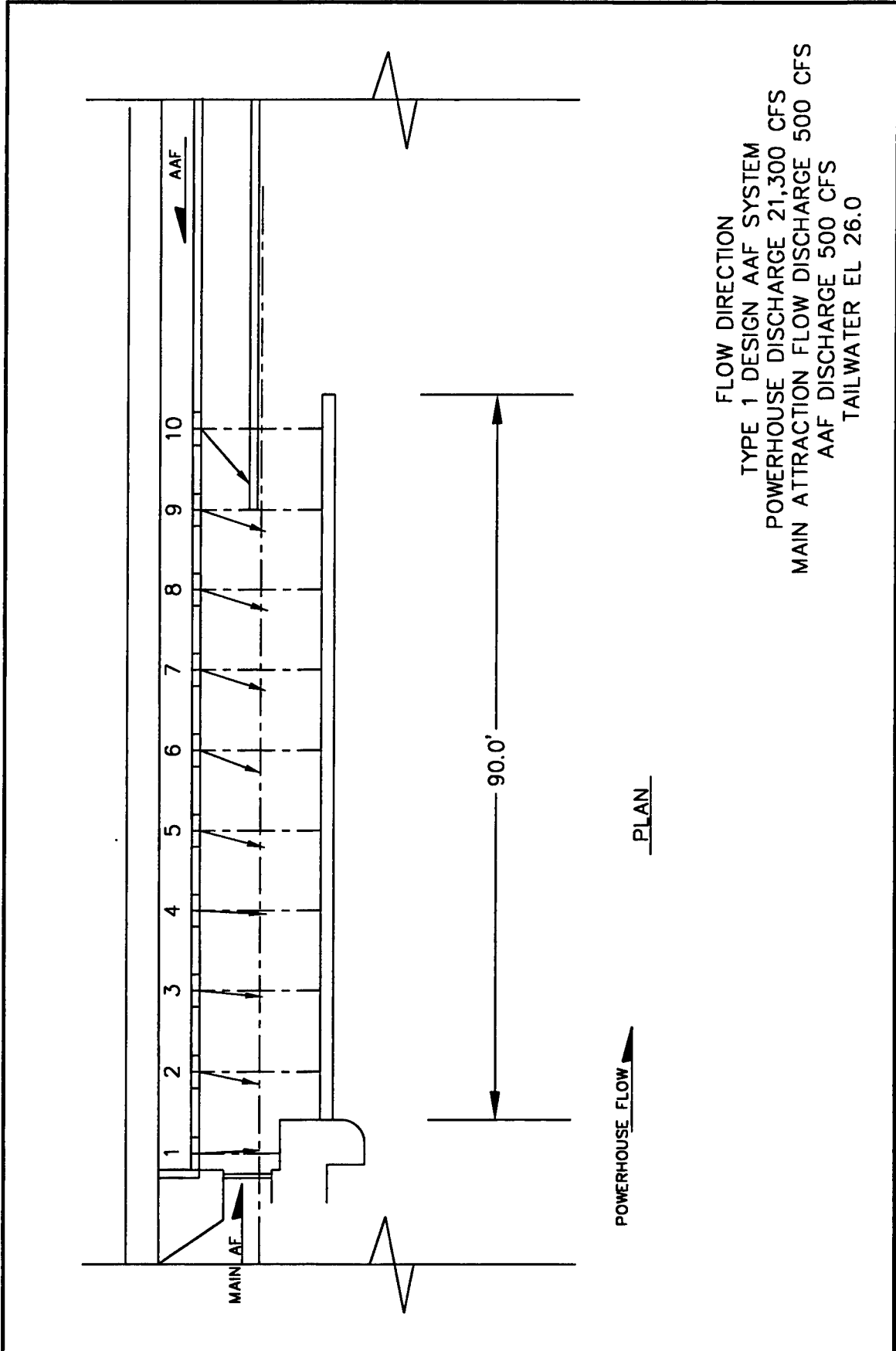

FLOW DIRECTION
 TYPE 1 DESIGN AAF SYSTEM
 POWERHOUSE DISCHARGE 21,300 CFS
 MAIN ATTRACTION FLOW DISCHARGE 500 CFS
 AAF DISCHARGE 500 CFS
 TAILWATER EL 26.0

Plate 6

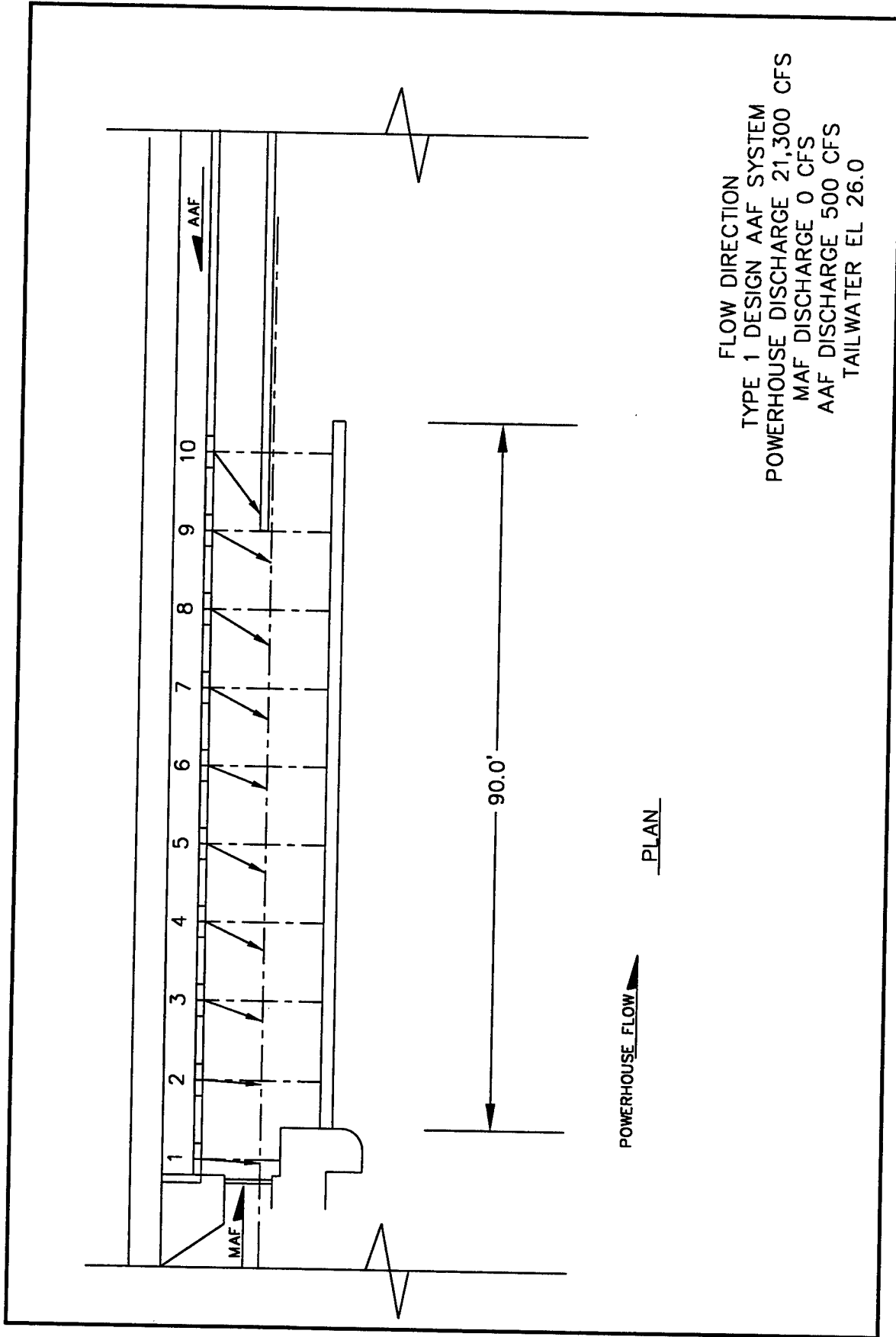

FLOW DIRECTION
 TYPE 1 DESIGN AAF SYSTEM
 POWERHOUSE DISCHARGE 21,300 CFS
 MAF DISCHARGE 0 CFS
 AAF DISCHARGE 500 CFS
 TAILWATER EL 26.0

POWERHOUSE FLOW →
 PLAN

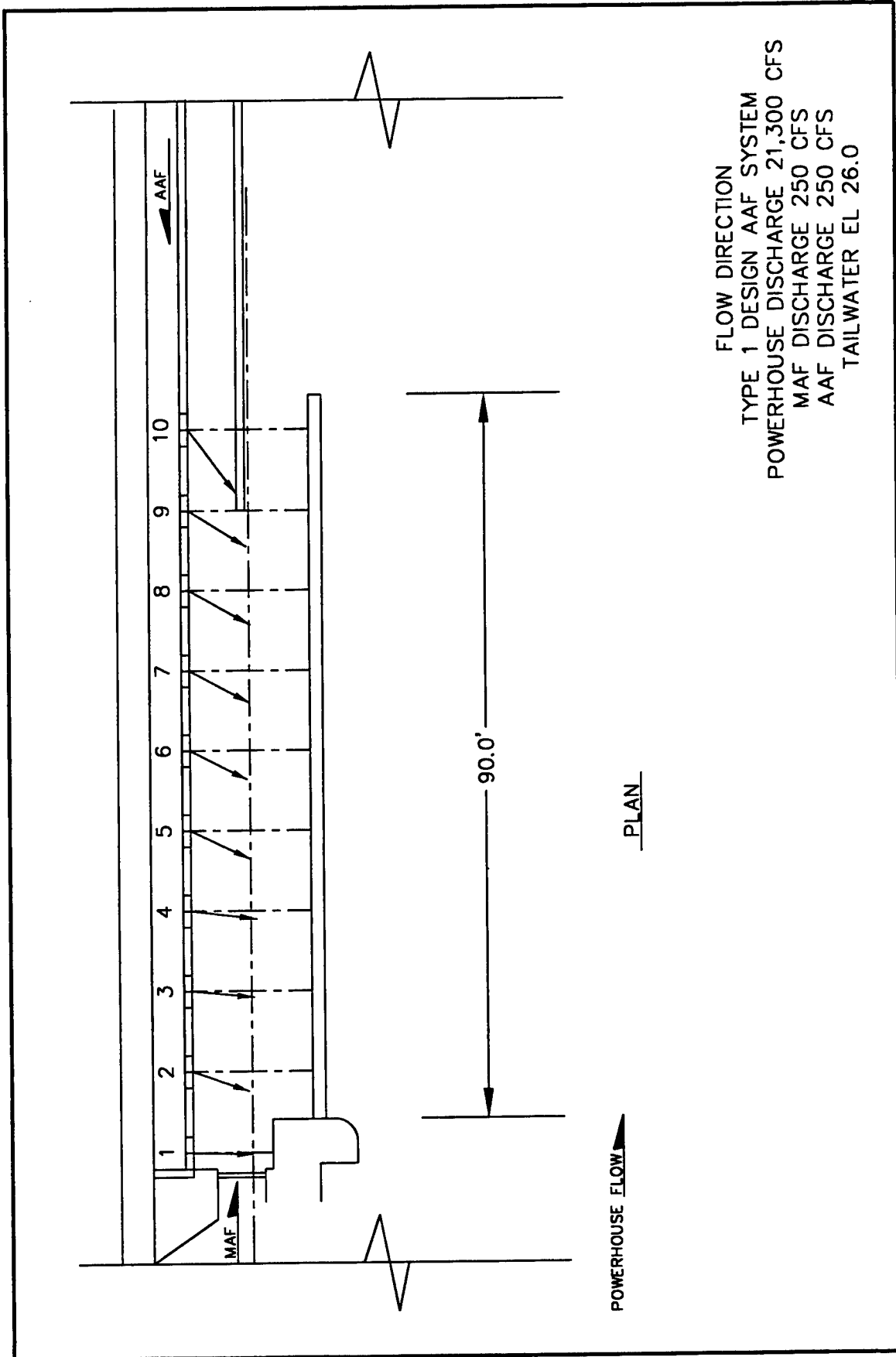

FLOW DIRECTION
 TYPE 1 DESIGN AAF SYSTEM
 POWERHOUSE DISCHARGE 21,300 CFS
 MAF DISCHARGE 250 CFS
 AAF DISCHARGE 250 CFS
 TAILWATER EL 26.0

Plate 8

UPSTREAM RANGE

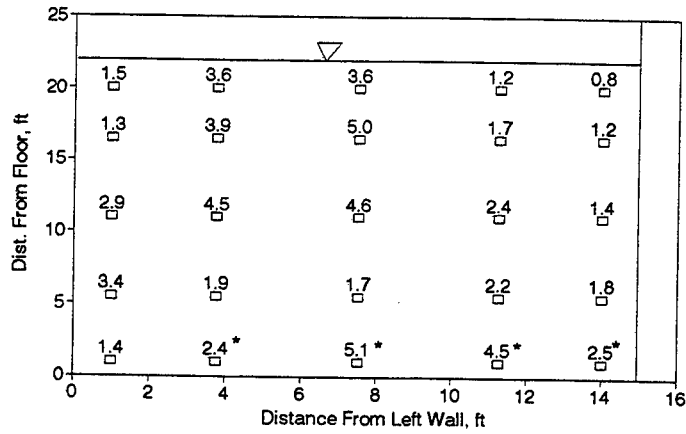

MIDDLE RANGE

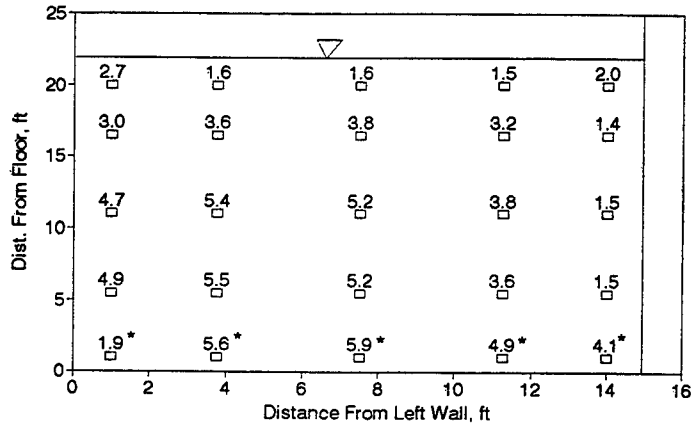

DOWNSTREAM RANGE

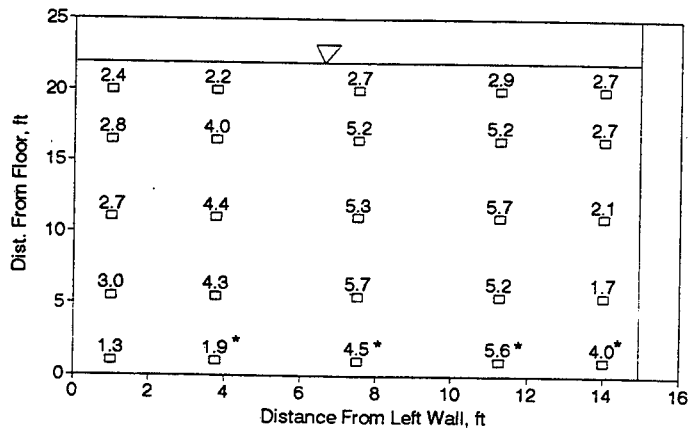

NOTE: * FLOW TOWARDS OUTSIDE WALL

FISH CHANNEL VELOCITIES
 TYPE 1 DESIGN AAF SYSTEM
 POWERHOUSE DISCHARGE 21,300 CFS
 MAF 500 CFS, AAF 500 CFS
 TAILWATER EL 26.0

UPSTREAM RANGE

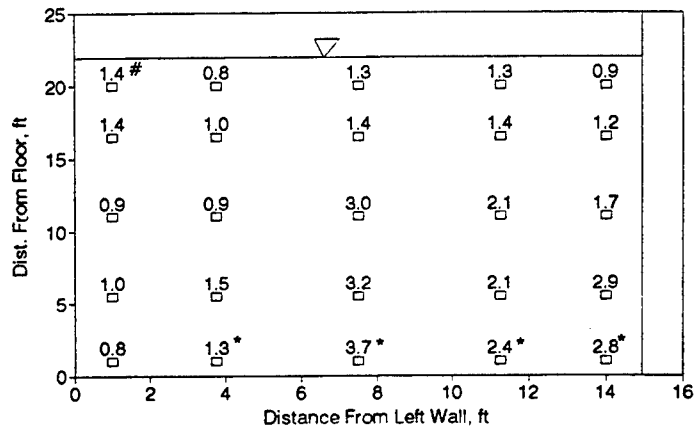

MIDDLE RANGE

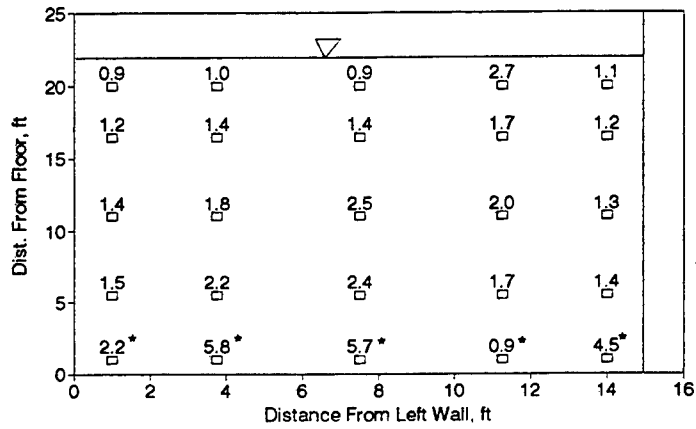

DOWNSTREAM RANGE

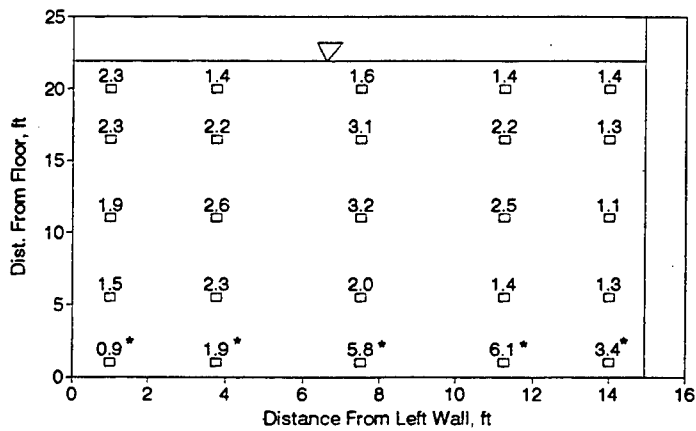

NOTE: * FLOW TOWARDS OUTSIDE WALL
FLOW UPSTREAM

FISH CHANNEL VELOCITIES
TYPE 1 DESIGN AAF SYSTEM
POWERHOUSE DISCHARGE 21,300 CFS
MAF 0 CFS, AAF 500 CFS
TAILWATER EL 26.0

UPSTREAM RANGE

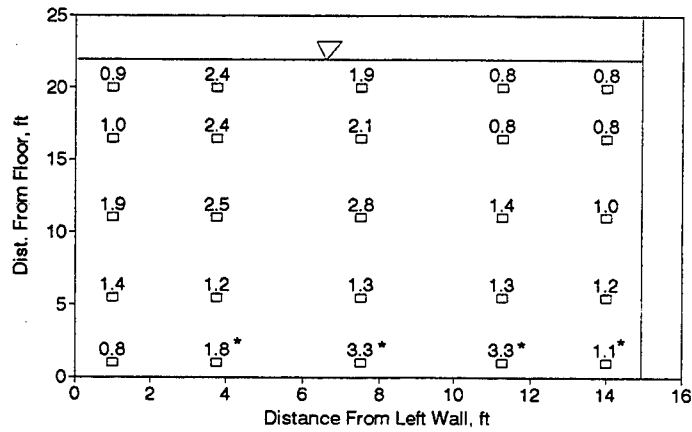

MIDDLE RANGE

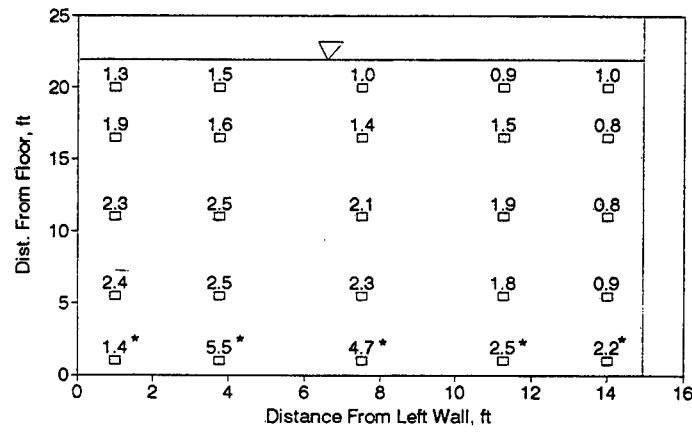

DOWNSTREAM RANGE

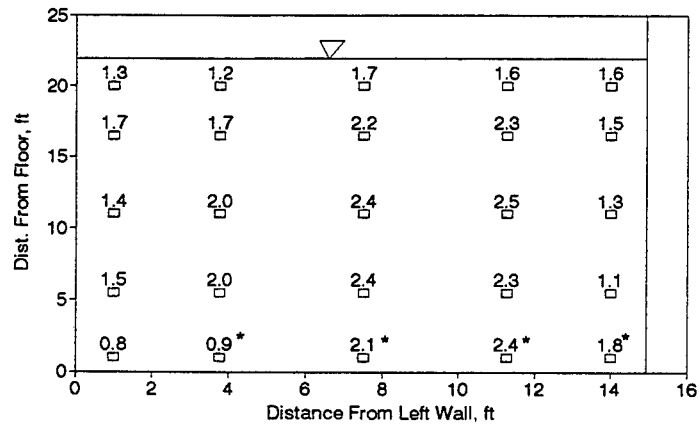

NOTE: * FLOW TOWARDS OUTSIDE WALL

FISH CHANNEL VELOCITIES
 TYPE 1 DESIGN AAF SYSTEM
 POWERHOUSE DISCHARGE 21,300 CFS
 MAF 250 CFS, AAF 250 CFS
 TAILWATER EL 26.0

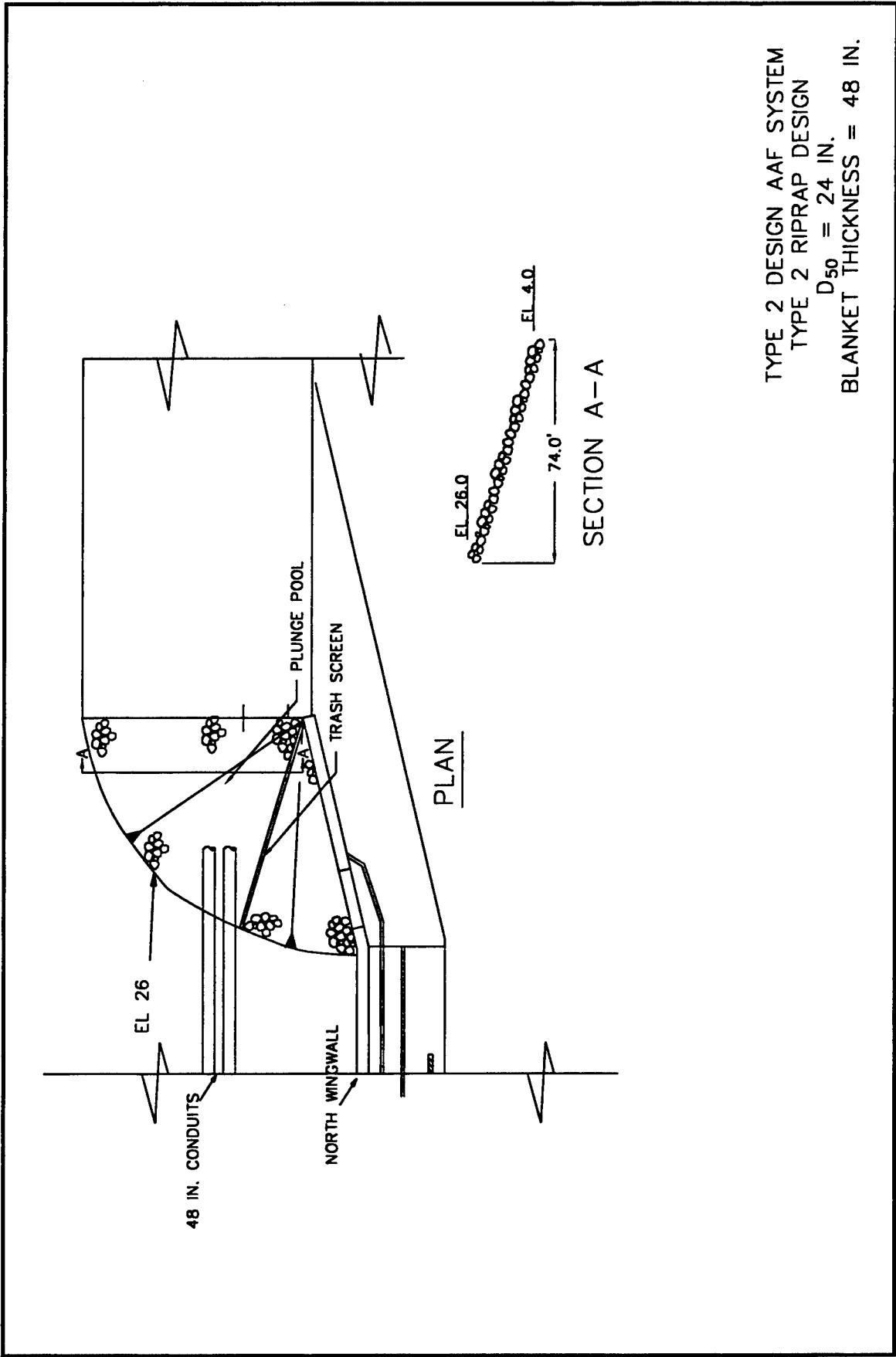

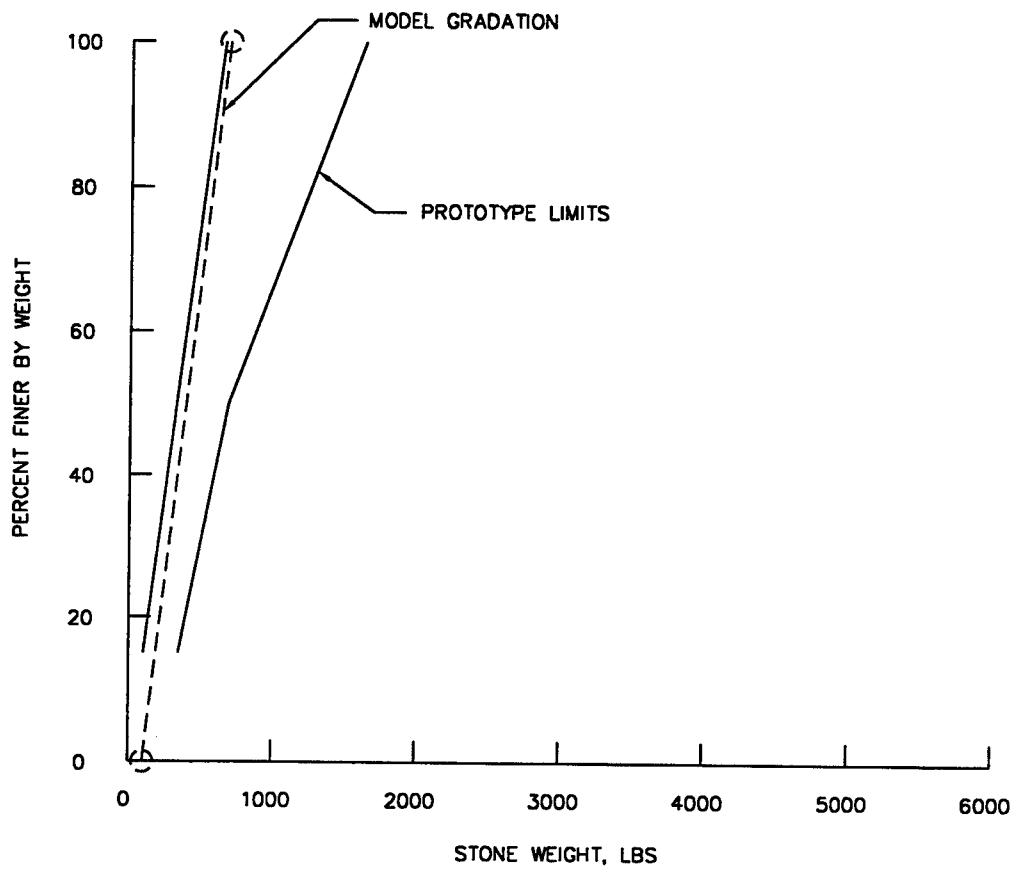

TYPE 2 DESIGN AAF SYSTEM
 TYPE 2 DESIGN RIPRAP GRADATION
 $D_{50} = 24$ IN.
 BLANKET THICKNESS = 48 IN.

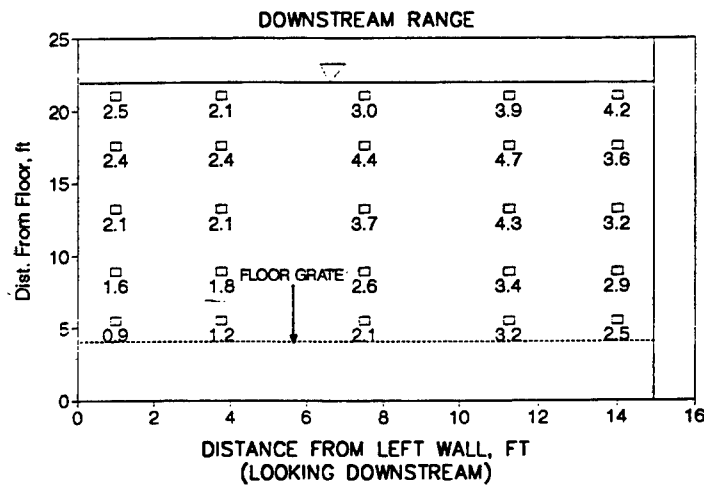
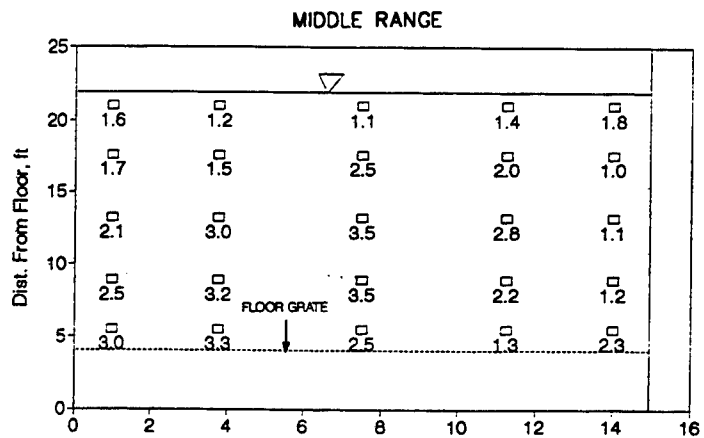
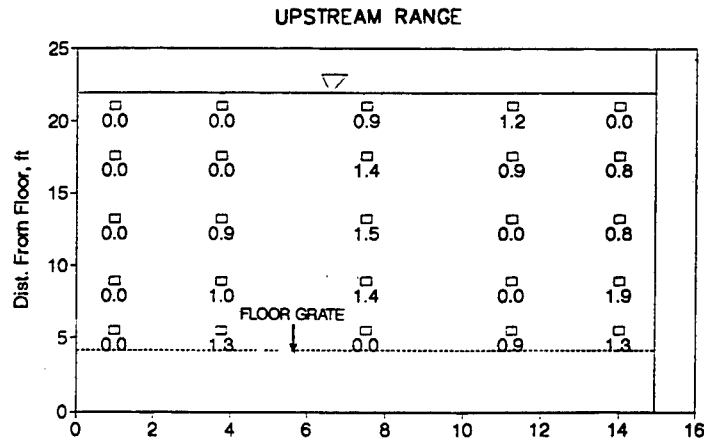

NOTE: AVG. HORIZ. COMPONENT
IN D/S DIRECTION, FT/SEC

FISH CHANNEL VELOCITIES
TYPE 2 DESIGN AAF SYSTEM
POWERHOUSE DISCHARGE 21,300 CFS
MAF 150 CFS, AAF 500 CFS
TAILWATER EL 26.0

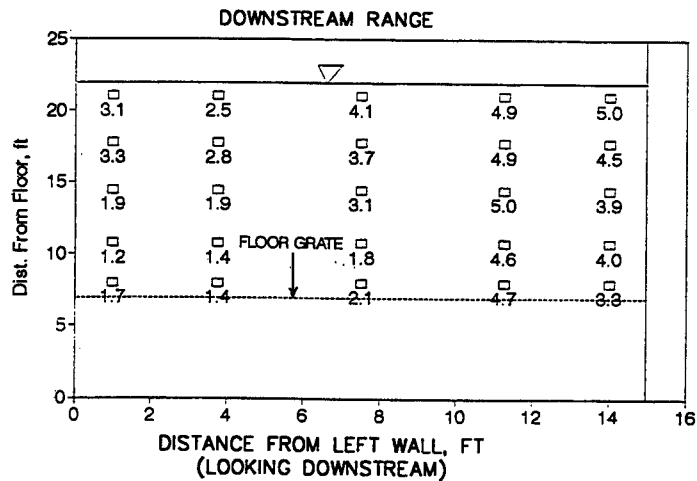
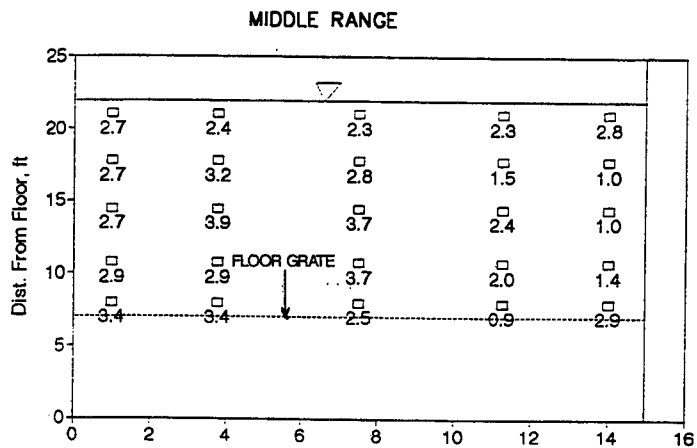
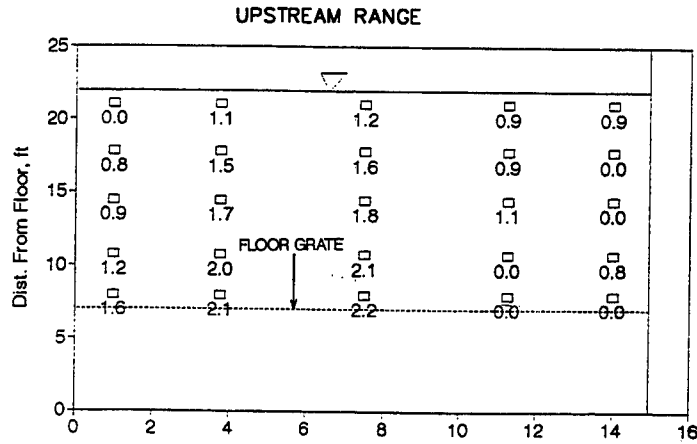

NOTE: AVG. HORIZ. COMPONENT
IN D/S DIRECTION, FT/SEC

FISH CHANNEL VELOCITIES
TYPE 2 DESIGN AAF SYSTEM
TYPE 2 FLOOR GRATE
POWERHOUSE DISCHARGE 21,300 CFS
MAF 150 CFS, AAF 500 CFS
TAILWATER EL 26.0

UPSTREAM RANGE

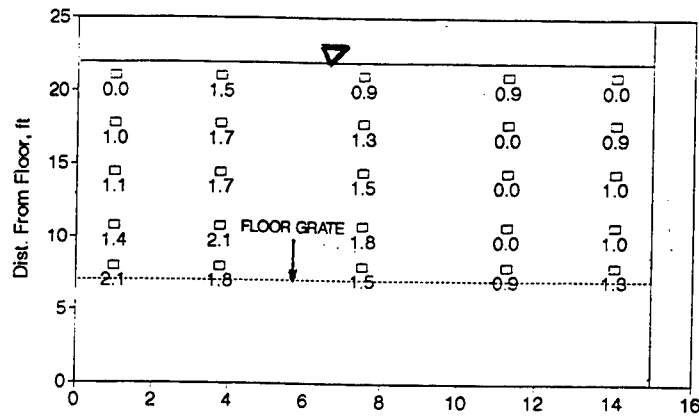

MIDDLE RANGE

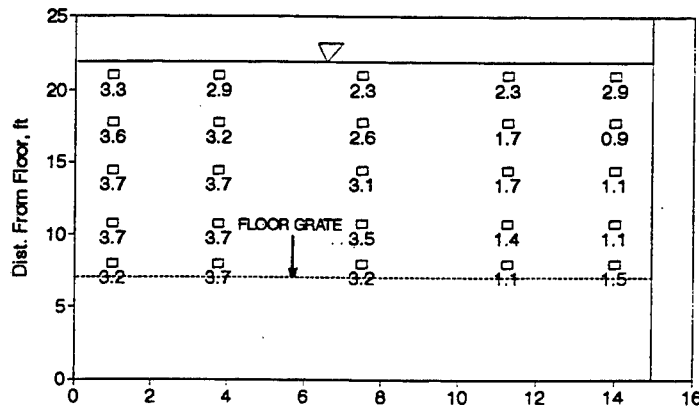

DOWNSTREAM RANGE

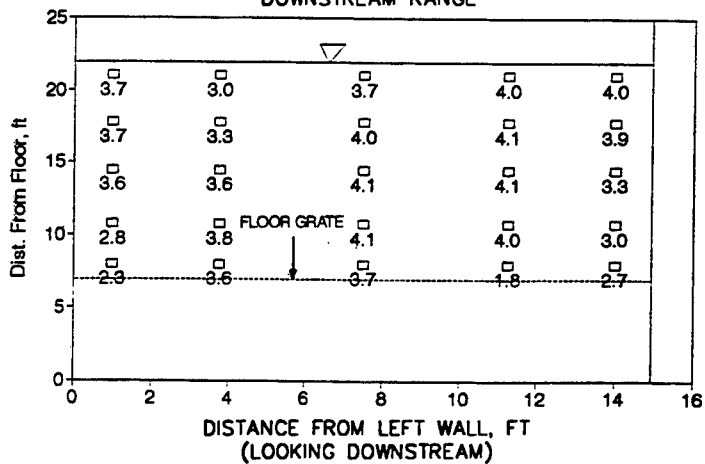

NOTE: AVG. HORIZ. COMPONENT
IN D/S DIRECTION, FT/SEC

FISH CHANNEL VELOCITIES
TYPE 2 DESIGN AAF SYSTEM
TYPE 2 PORTED CHANNEL DESIGN
POWERHOUSE DISCHARGE 21,300 CFS
MAF 150 CFS, AAF 500 CFS
TAILWATER EL 26.0

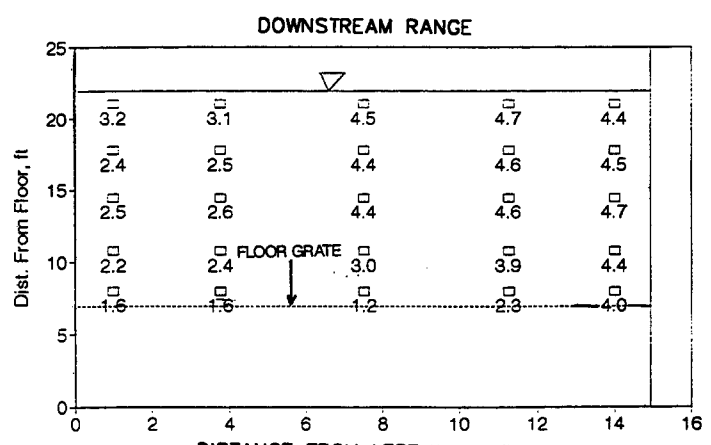
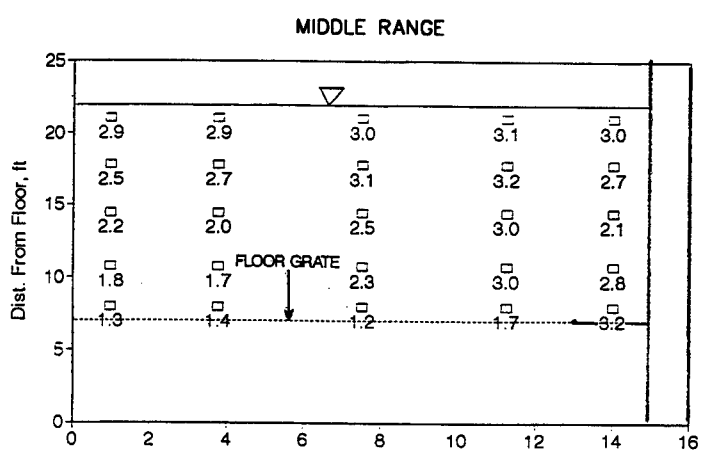
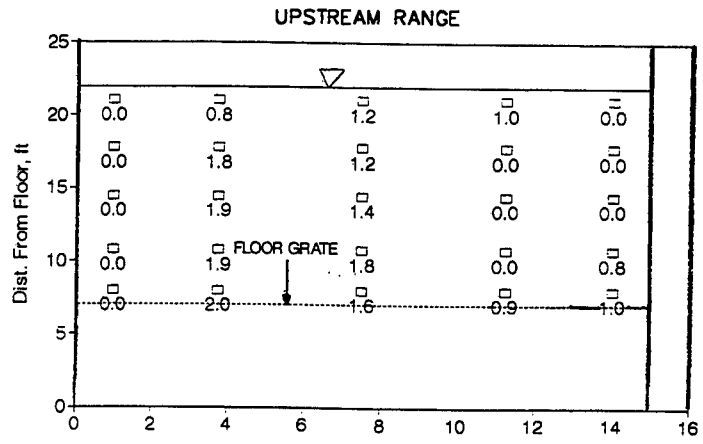

DISTANCE FROM LEFT WALL, FT
(LOOKING DOWNSTREAM)

NOTE: AVG. HORIZ. COMPONENT
IN D/S DIRECTION, FT/SEC

FISH CHANNEL VELOCITIES
TYPE 2 DESIGN AAF SYSTEM
TYPE 4 FLOOR GRATE
POWERHOUSE DISCHARGE 21,300 CFS
MAF 150 CFS, AAF 500 CFS
TAILWATER EL 26.0

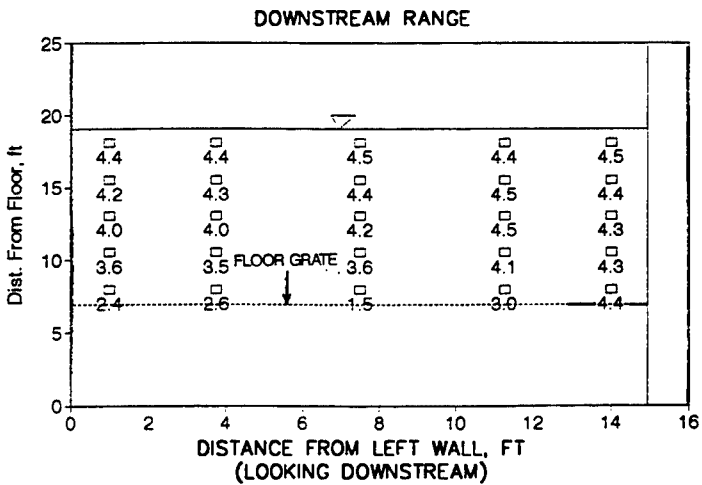
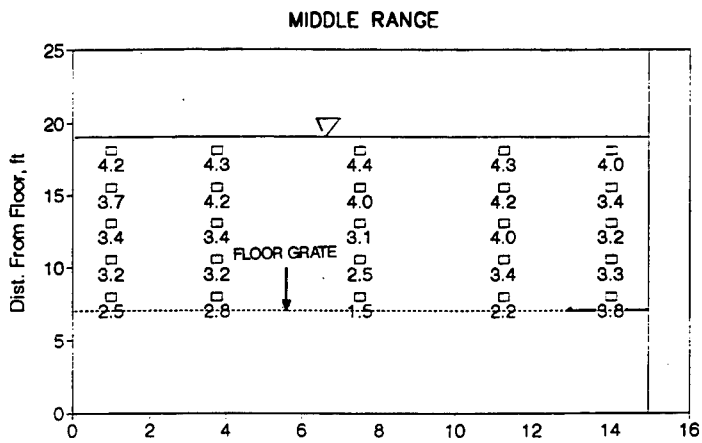
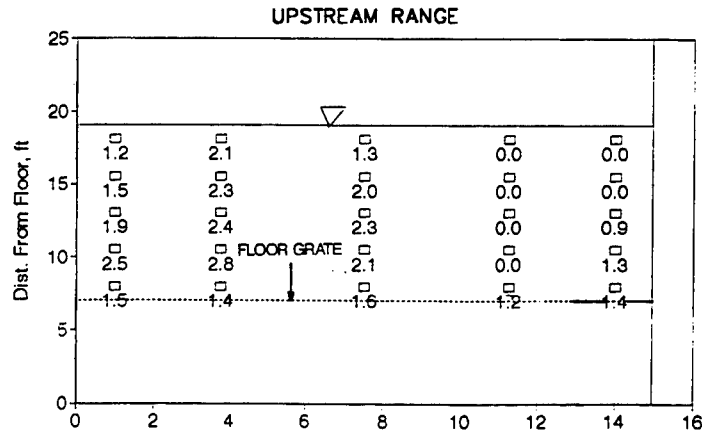

NOTE: AVG. HORIZ. COMPONENT
IN D/S DIRECTION, FT/SEC

FISH CHANNEL VELOCITIES
TYPE 2 DESIGN AAF SYSTEM
TYPE 4 FLOOR GRATE
POWERHOUSE DISCHARGE 21,300 CFS
MAF 150 CFS, AAF 500 CFS
TAILWATER EL 23.1

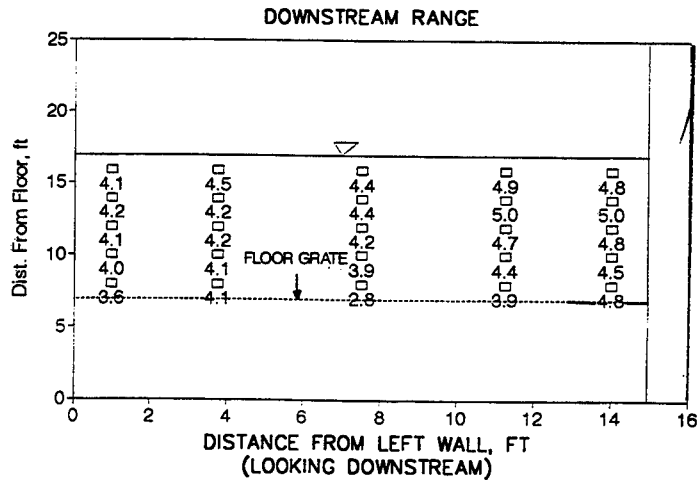
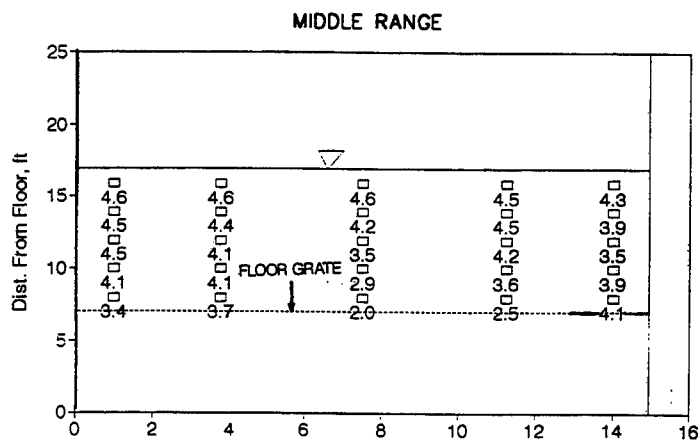
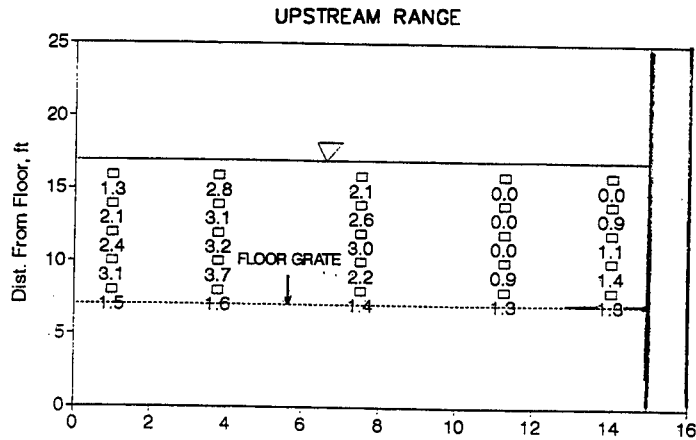

NOTE: AVG. HORIZ. COMPONENT
IN D/S DIRECTION, FT/SEC

FISH CHANNEL VELOCITIES
TYPE 2 DESIGN AAF SYSTEM
TYPE 4 FLOOR GRATE
POWERHOUSE DISCHARGE 14,200 CFS
MAF 150 CFS, AAF 500 CFS
TAILWATER EL 20.9

UPSTREAM RANGE

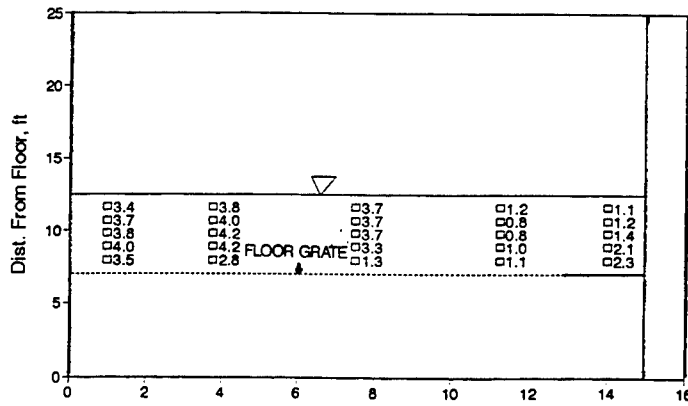

MIDDLE RANGE

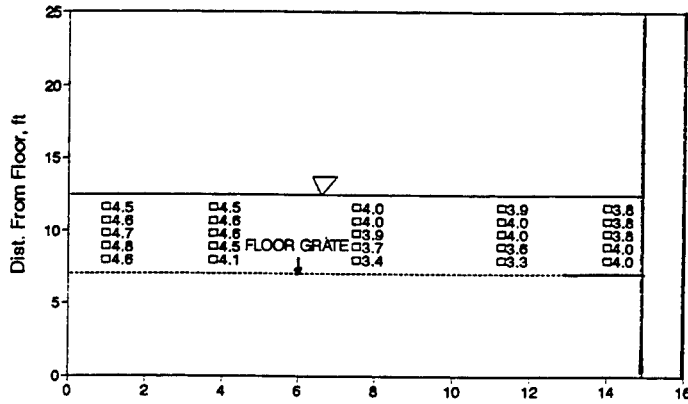

DOWNSTREAM RANGE

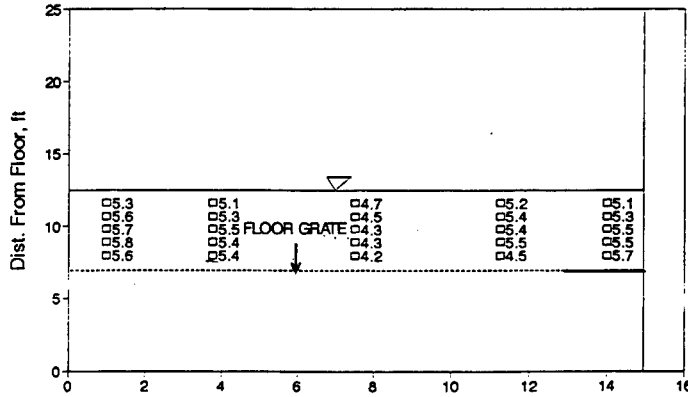

DISTANCE FROM LEFT WALL, FT
(LOOKING DOWNSTREAM)

NOTE: AVG. HORIZ. COMPONENT
IN D/S DIRECTION, FT/SEC

FISH CHANNEL VELOCITIES
TYPE 2 DESIGN AAF SYSTEM
TYPE 4 FLOOR GRATE
POWERHOUSE DISCHARGE 7,100 CFS
MAF 150 CFS, AAF 500 CFS
TAILWATER EL 16.6

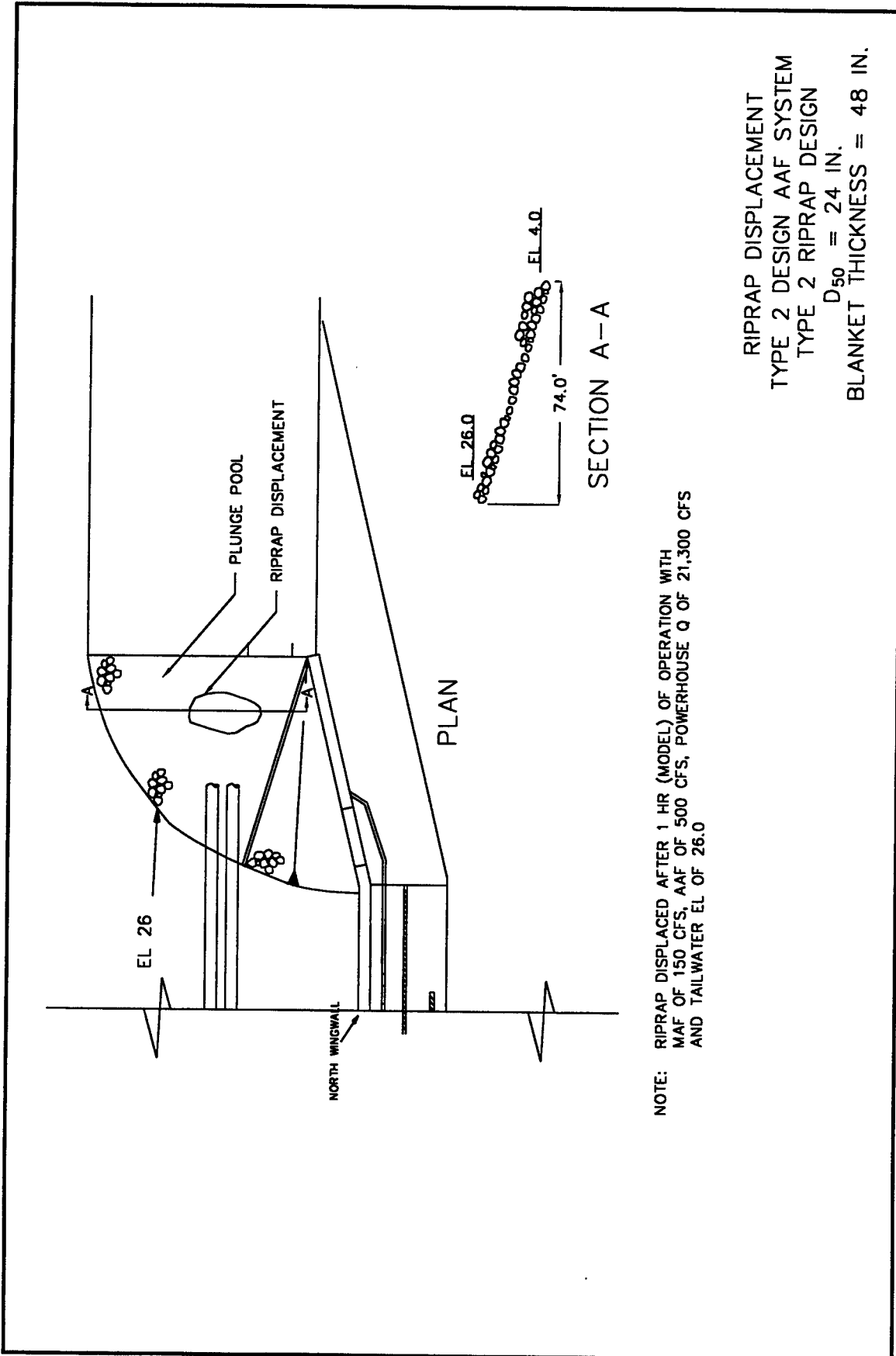

NOTE: RIPRAP DISPLACED AFTER 1 HR (MODEL) OF OPERATION WITH
 MAF OF 150 CFS, AAF OF 500 CFS, POWERHOUSE Q OF 21,300 CFS
 AND TAILWATER EL OF 26.0

RIPRAP DISPLACEMENT
 TYPE 2 DESIGN AAF SYSTEM
 TYPE 2 RIPRAP DESIGN
 $D_{50} = 24$ IN.
 BLANKET THICKNESS = 48 IN.

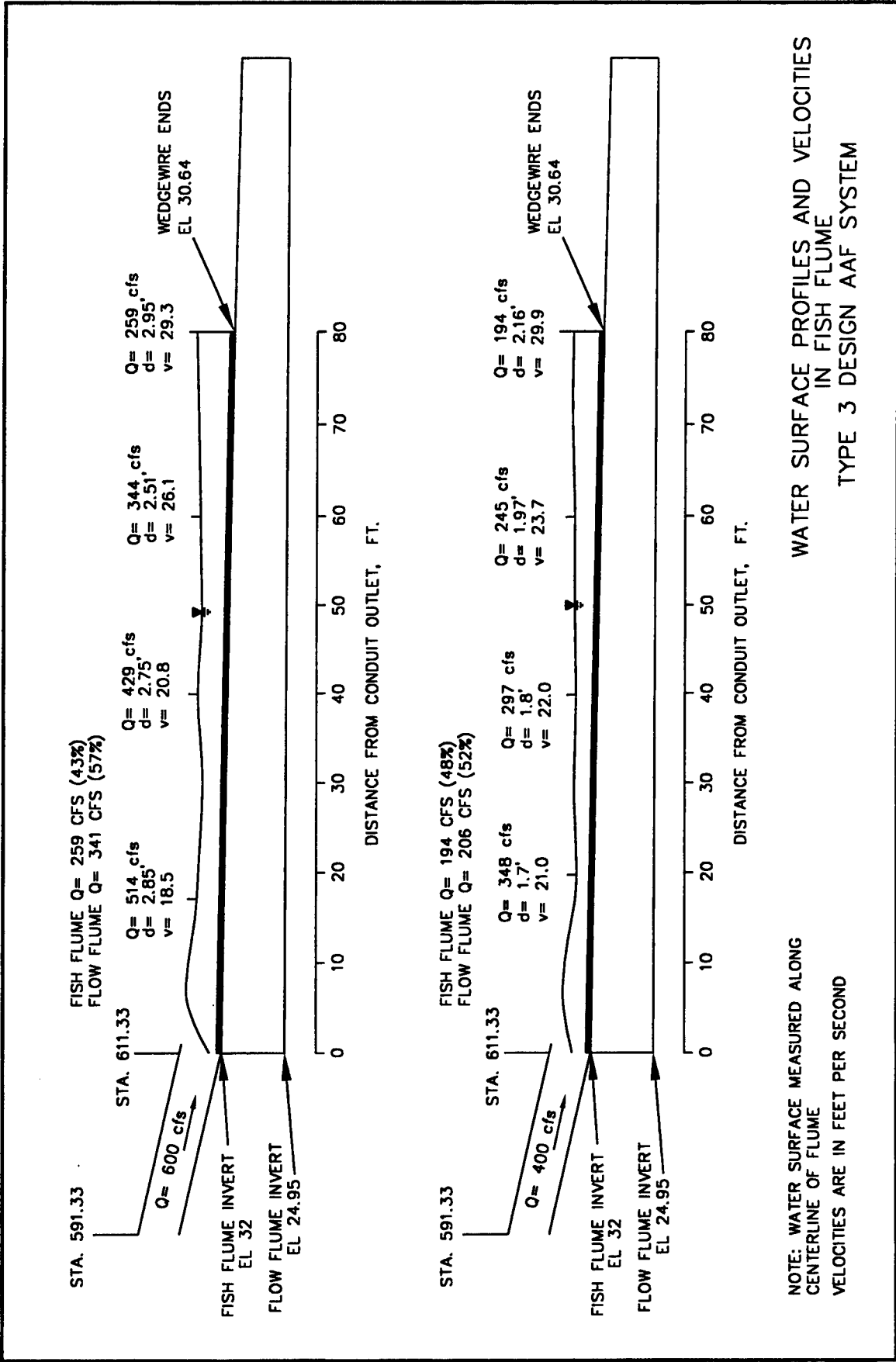

WATER SURFACE PROFILES AND VELOCITIES
IN FISH FLUME
TYPE 3 DESIGN AAF SYSTEM

NOTE: WATER SURFACE MEASURED ALONG
CENTERLINE OF FLUME
VELOCITIES ARE IN FEET PER SECOND

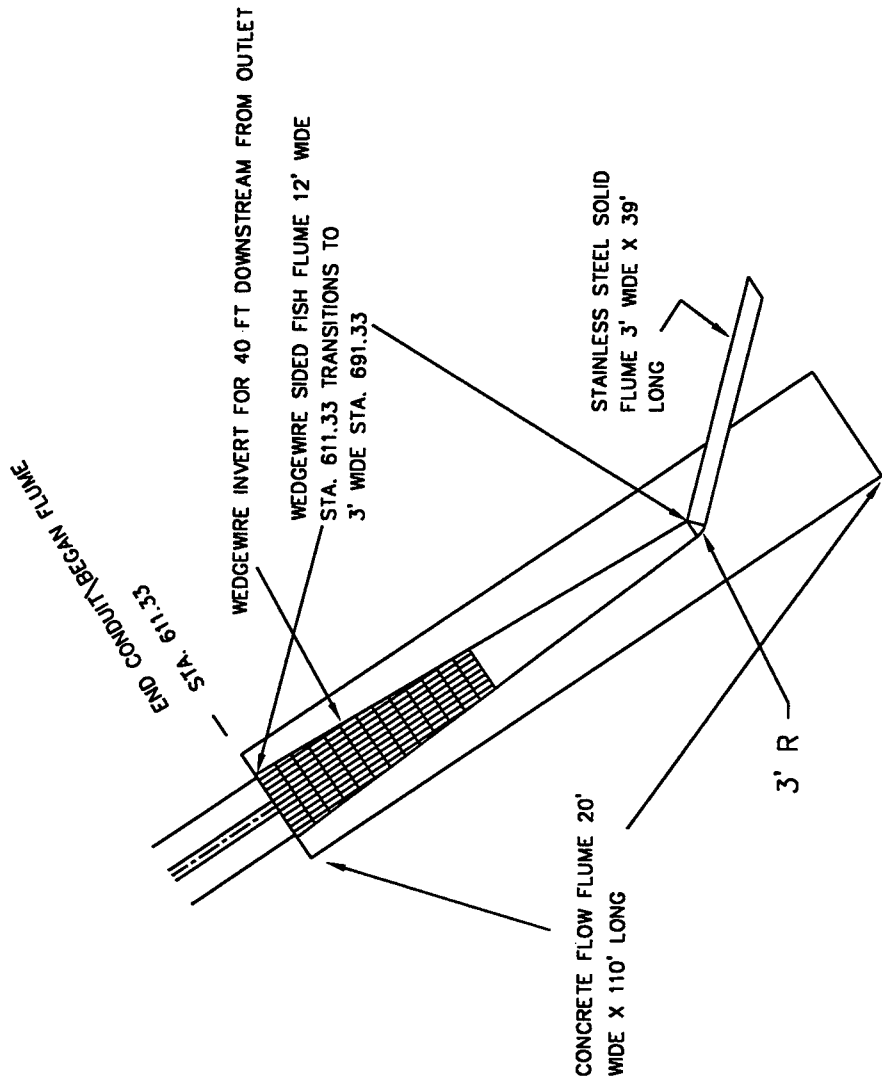

PLAN

TYPE 3 DESIGN AAF SYSTEM
TYPE 3 DESIGN FISH FLUME

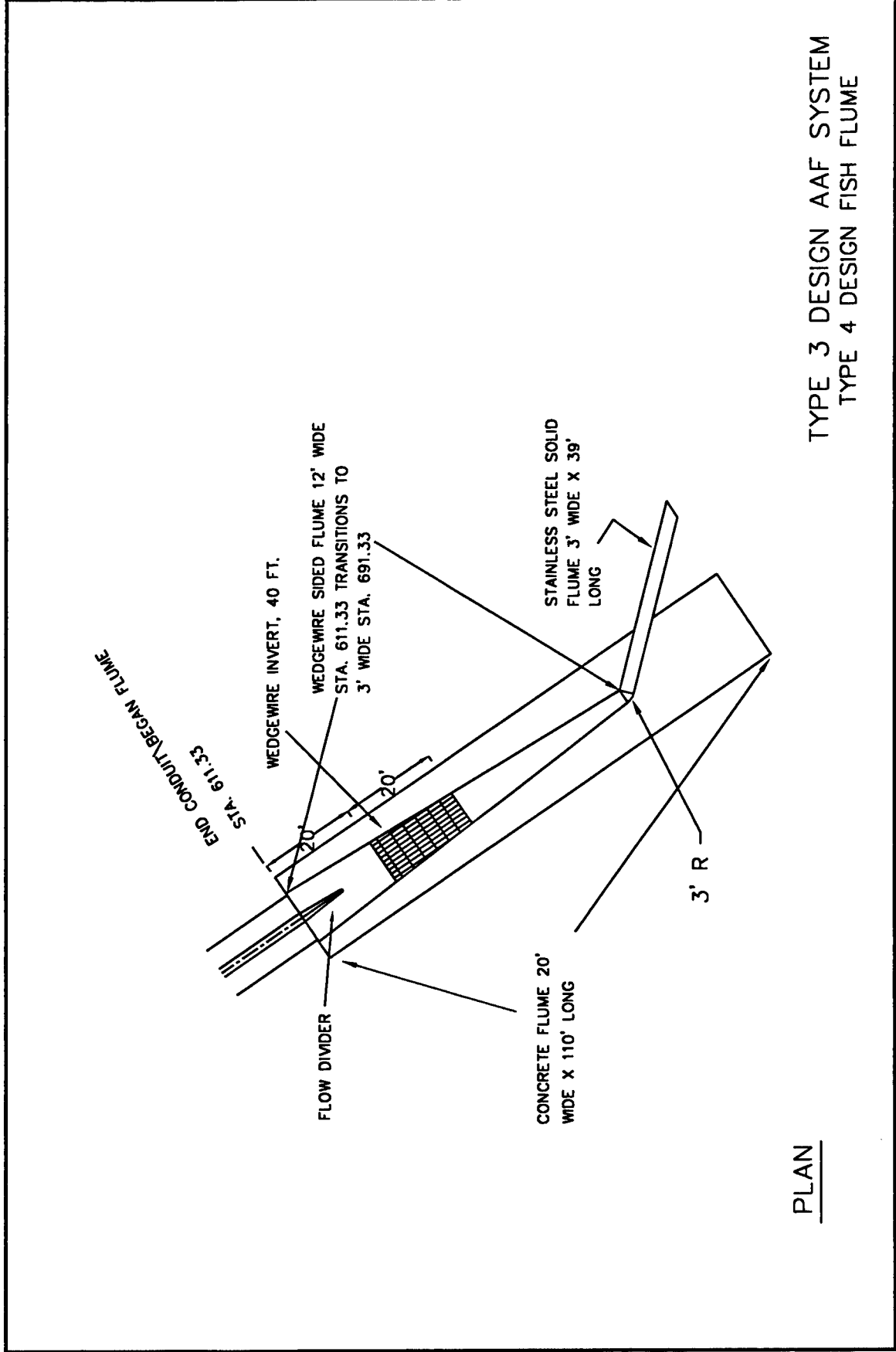

PLAN

TYPE 3 DESIGN AAF SYSTEM
TYPE 4 DESIGN FISH FLUME

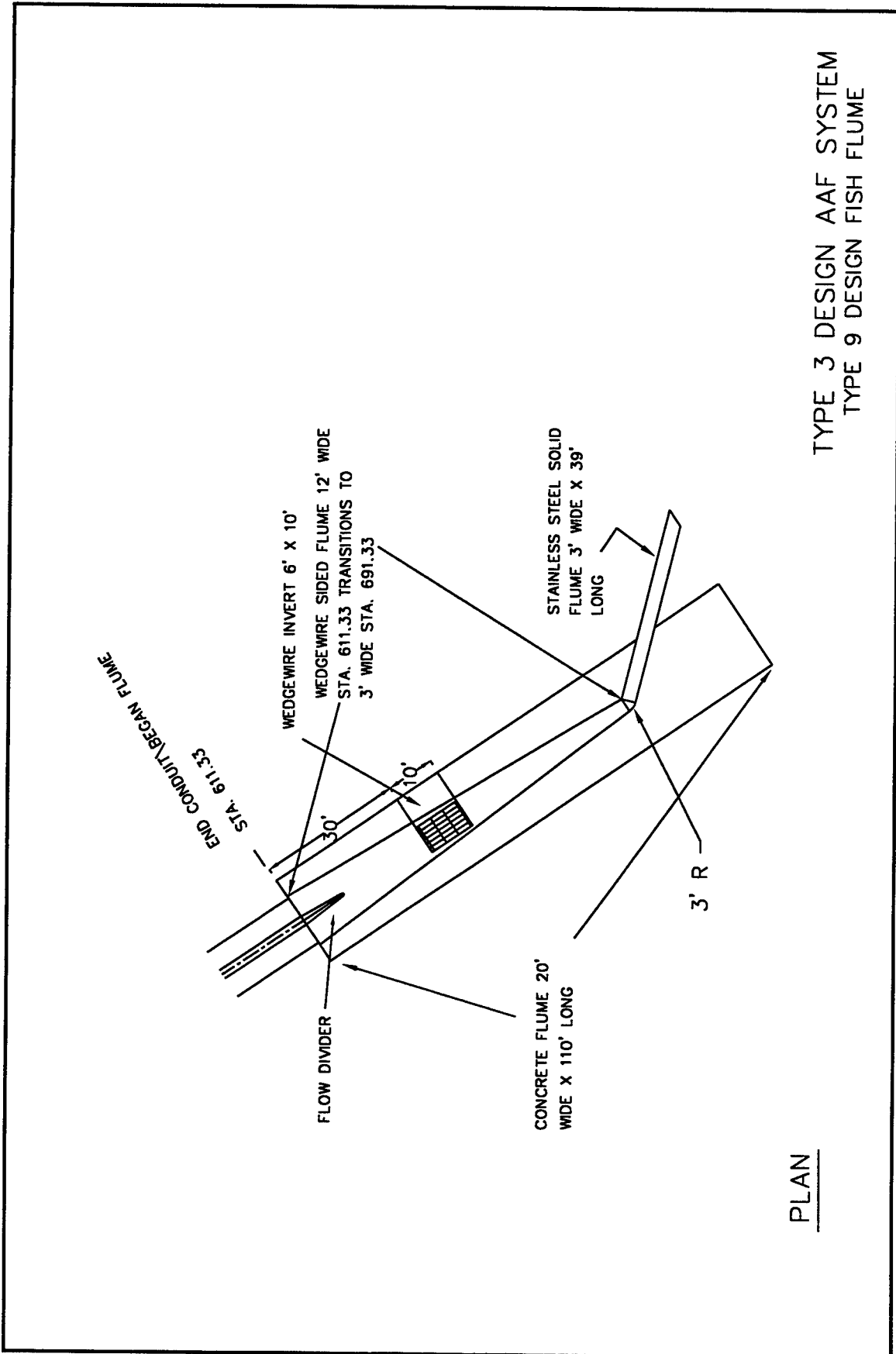

PLAN

TYPE 3 DESIGN AAF SYSTEM
 TYPE 9 DESIGN FISH FLUME

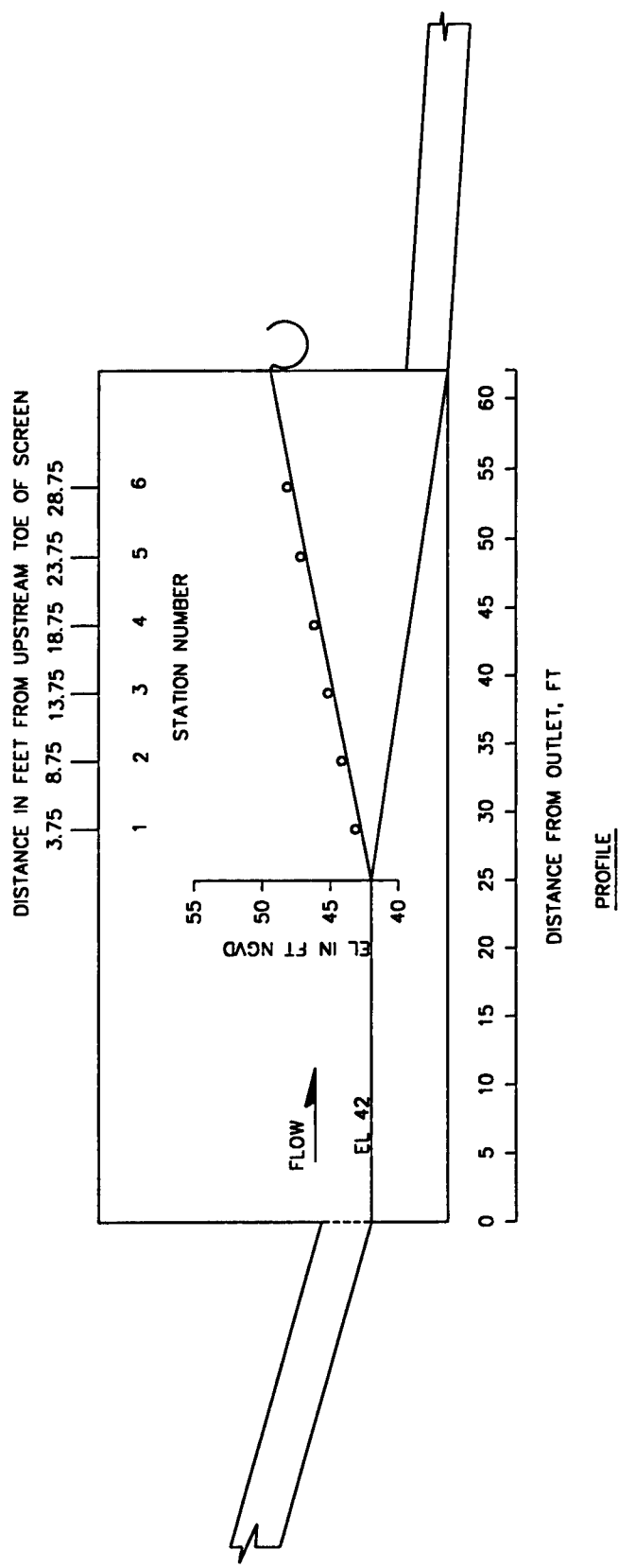

NOTE: BOTTOM VELOCITIES WERE MEASURED 5 INCHES ABOVE SCREEN

VELOCITY STATIONS
TYPE 4 DESIGN AAF SYSTEM

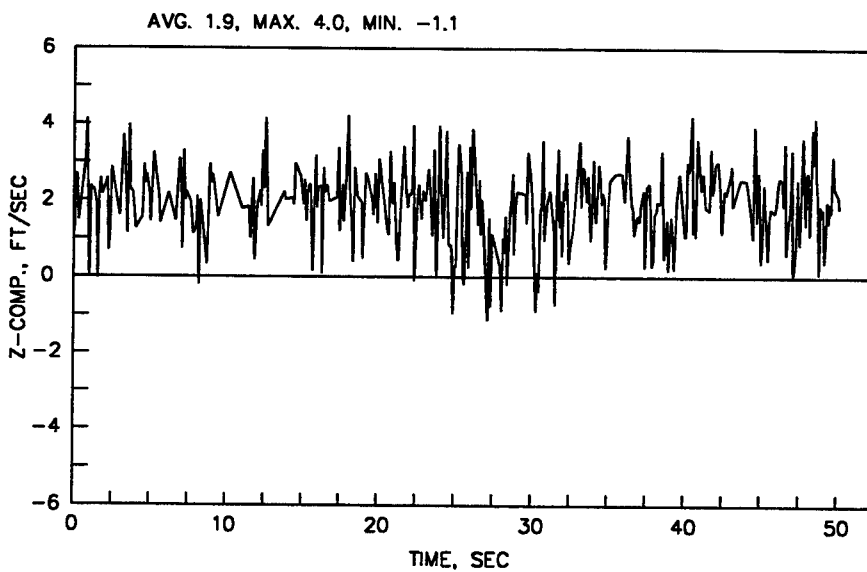
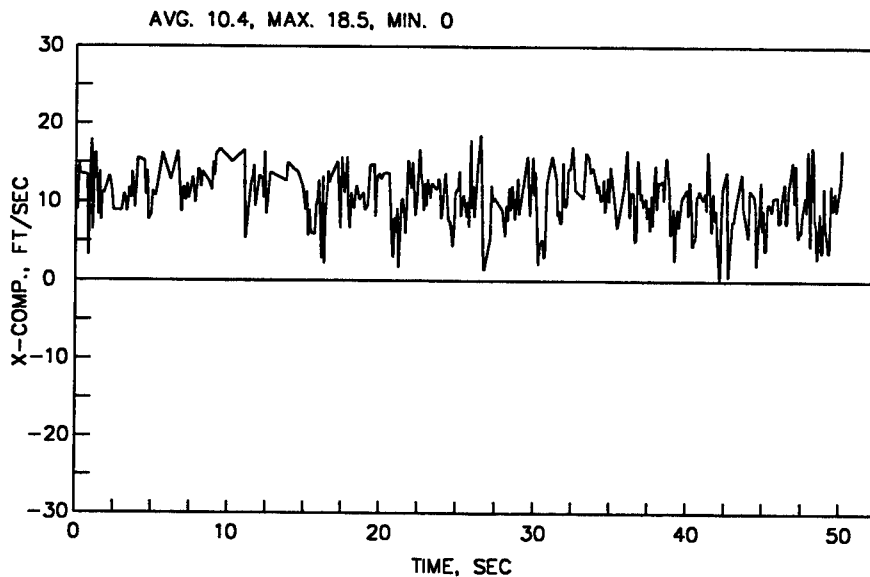

TIME HISTORIES OF VELOCITY
TYPE 4 AAF SYSTEM
STATION 1, 5 IN. ABOVE SCREEN
DISCHARGE 470 CFS, TW EL 50

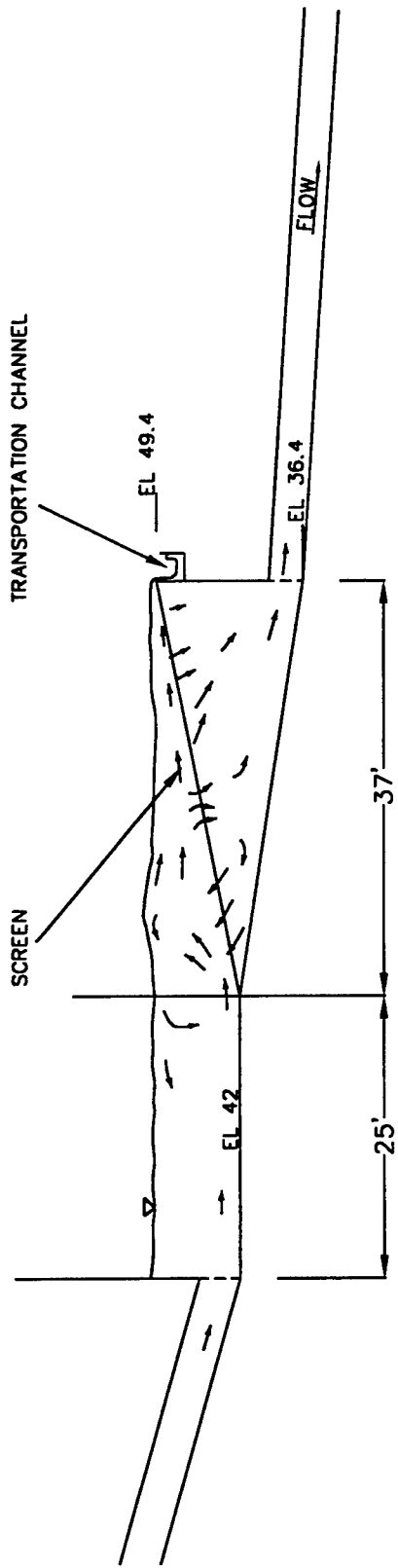

GENERAL FLOW PATTERNS
 TYPE 4 AAF SYSTEM
 DISCHARGE 470 CFS, TW EL 50
 TRANSPORTATION CHANNEL DISCHARGE 61 CFS

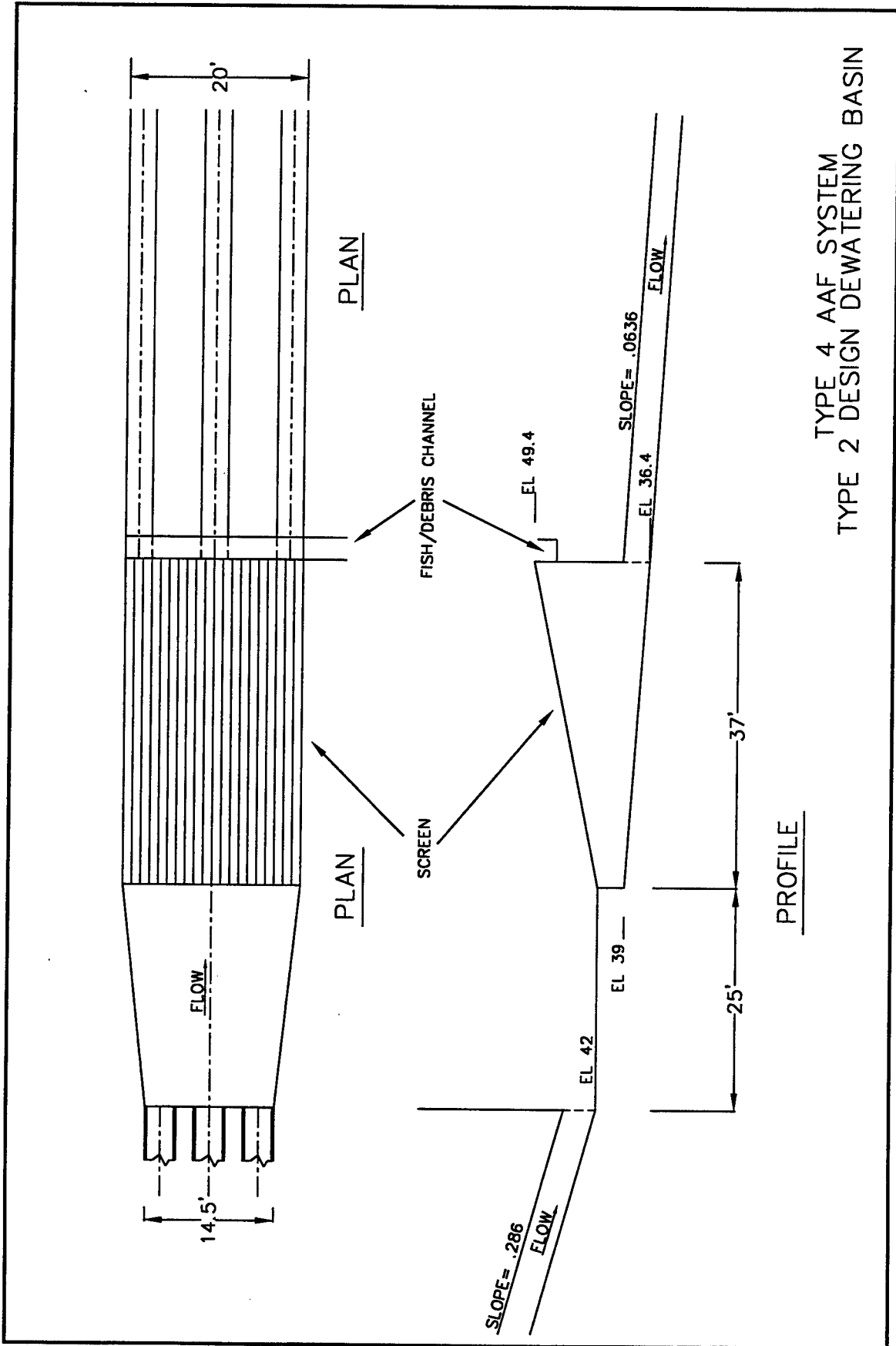

TYPE 4 AAF SYSTEM
TYPE 2 DESIGN DEWATERING BASIN

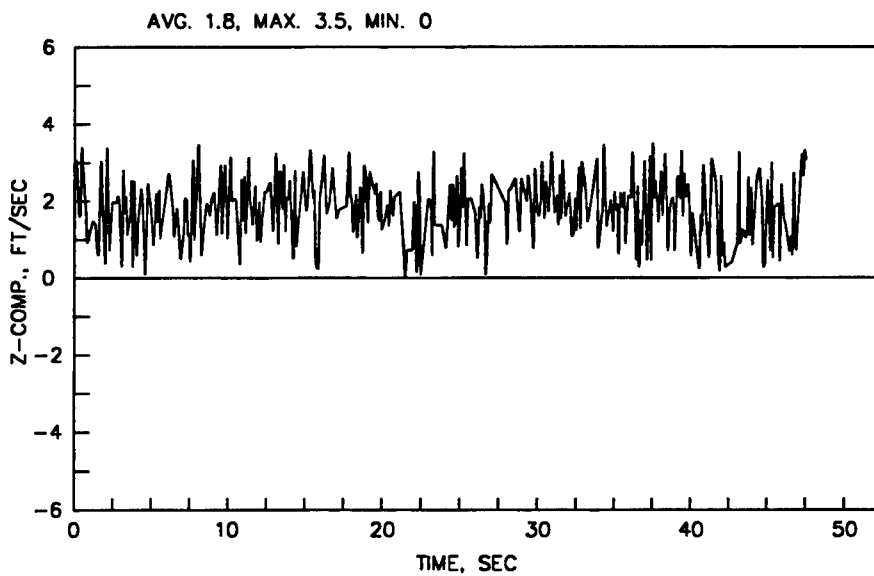
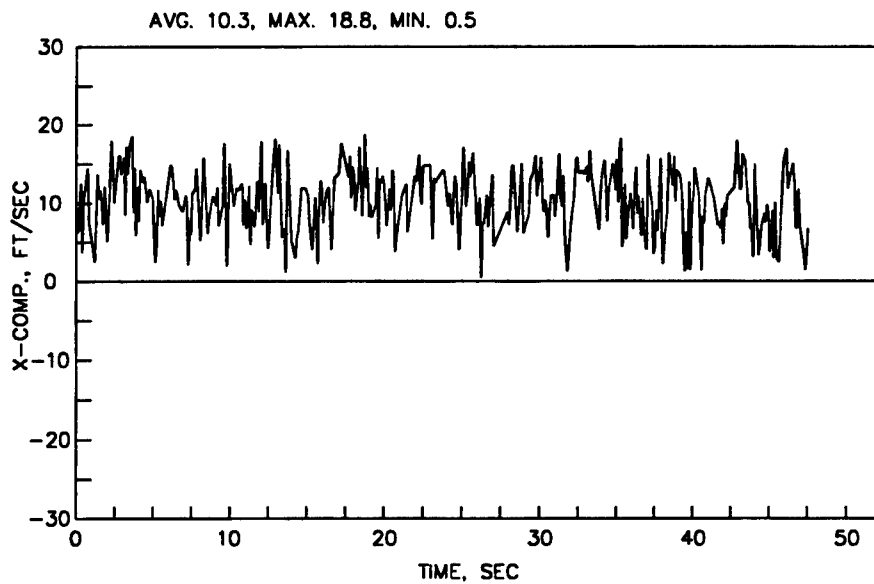

TIME HISTORIES OF VELOCITY
TYPE 4 AAF SYSTEM
TYPE 2 DEWATERING BASIN
STATION 1, 5 IN. ABOVE SCREEN
DISCHARGE 470 CFS, TW EL 50

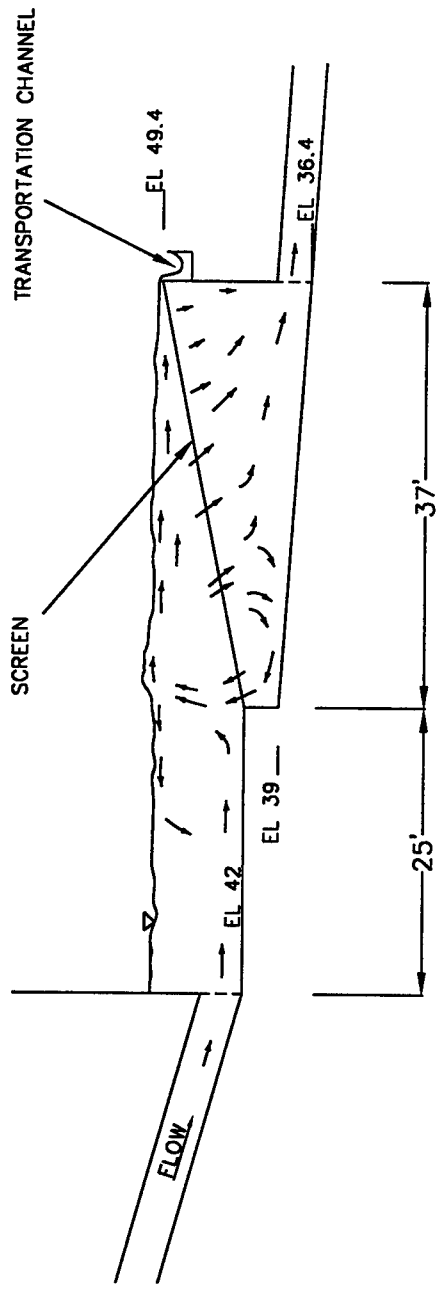

PROFILE

GENERAL FLOW PATTERNS
 TYPE 4 AAF SYSTEM
 TYPE 2 DEWATERING BASIN
 DISCHARGE 470 CFS, TW EL 50
 TRANSPORTATION CHANNEL DISCHARGE 57 CFS

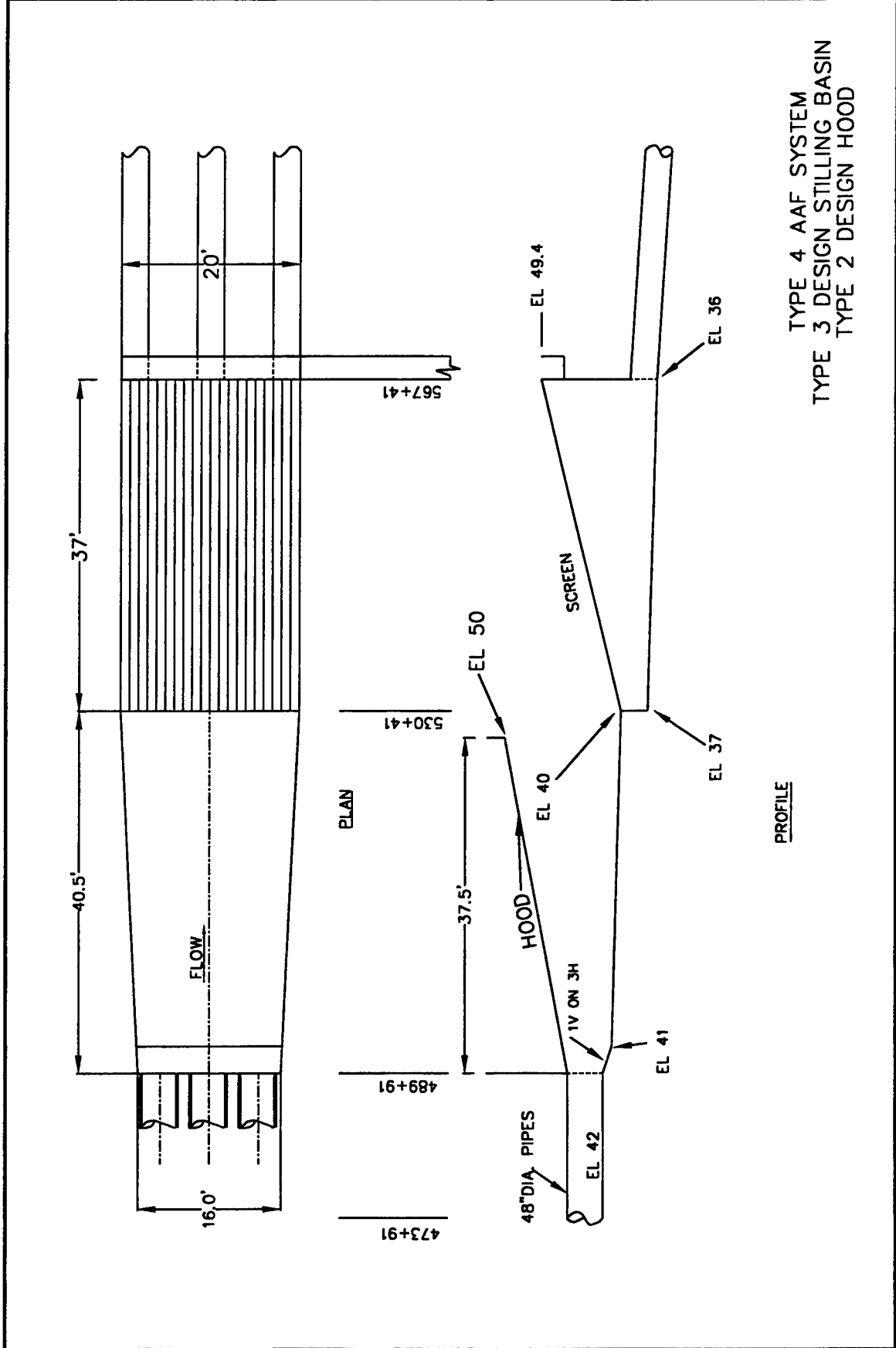

TYPE 4 AAF SYSTEM
 TYPE 3 DESIGN STILLING BASIN
 TYPE 2 DESIGN HOOD

Plate 32

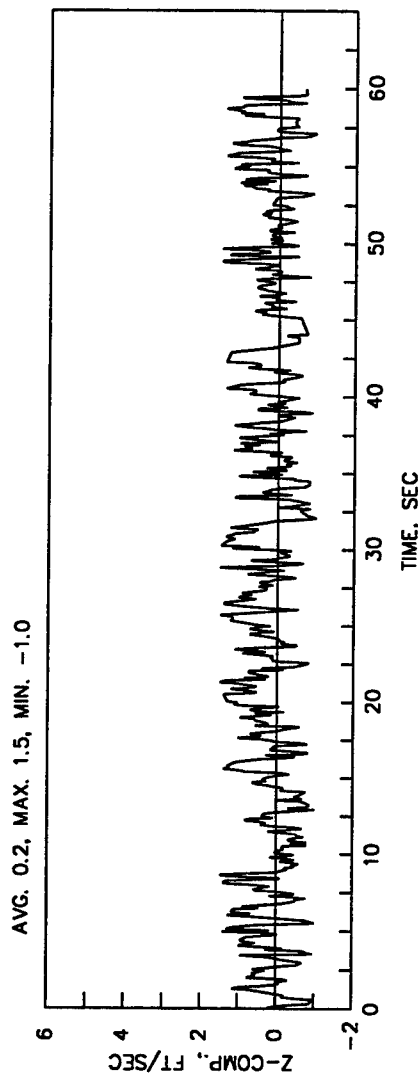
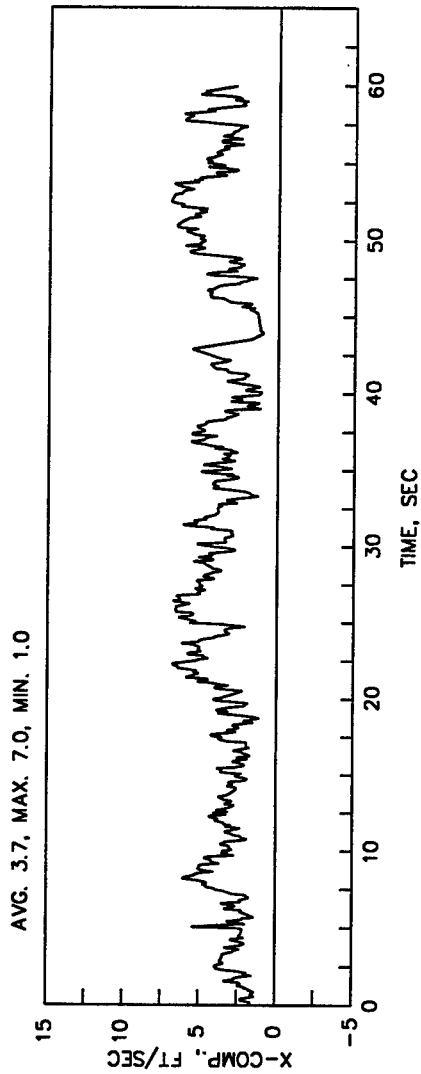

TIME HISTORIES OF VELOCITY
 TYPE 4 AAF SYSTEM
 TYPE 3 DESIGN STILLING BASIN
 STATION 1, 5 IN. ABOVE SCREEN
 DISCHARGE 470 CFS, TW EL 50

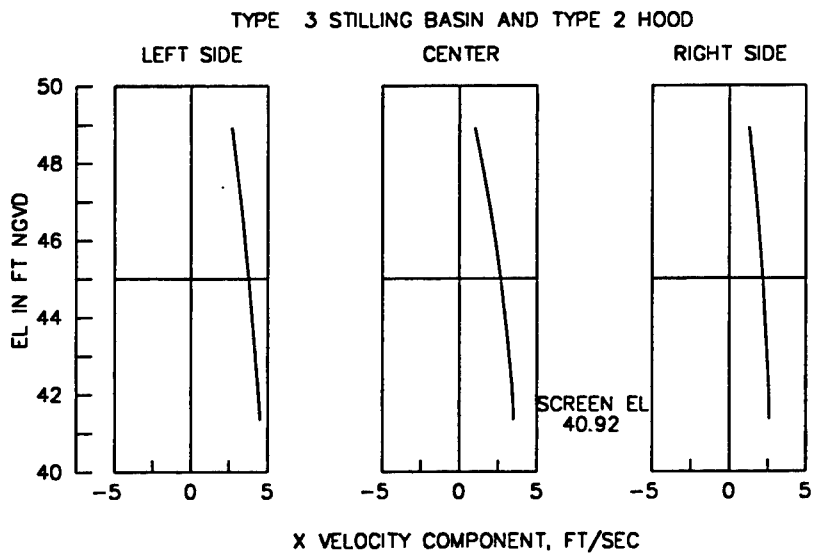
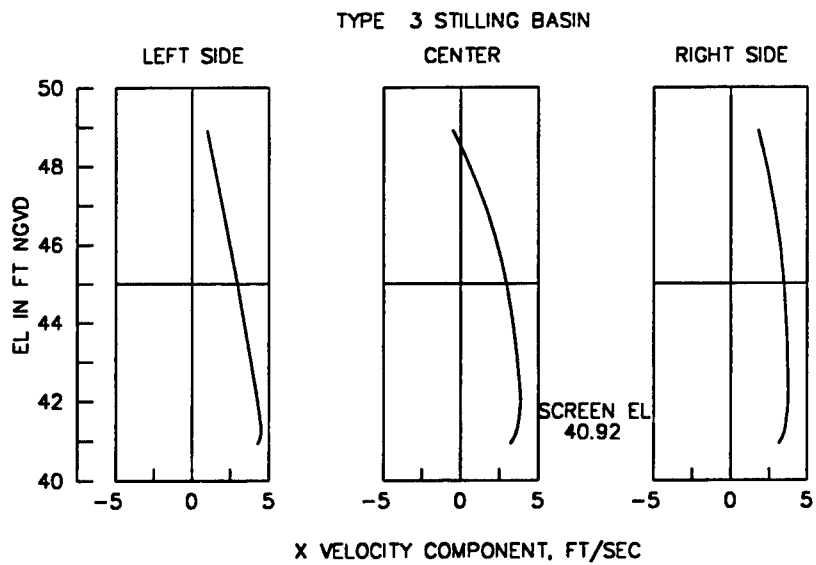

VELOCITY PROFILES
X-COMPONENT
TYPE 4 AAF SYSTEM
STATION 1, 5 IN. ABOVE SCREEN
DISCHARGE 470 CFS, TW EL 50

TYPE 3 STILLING BASIN

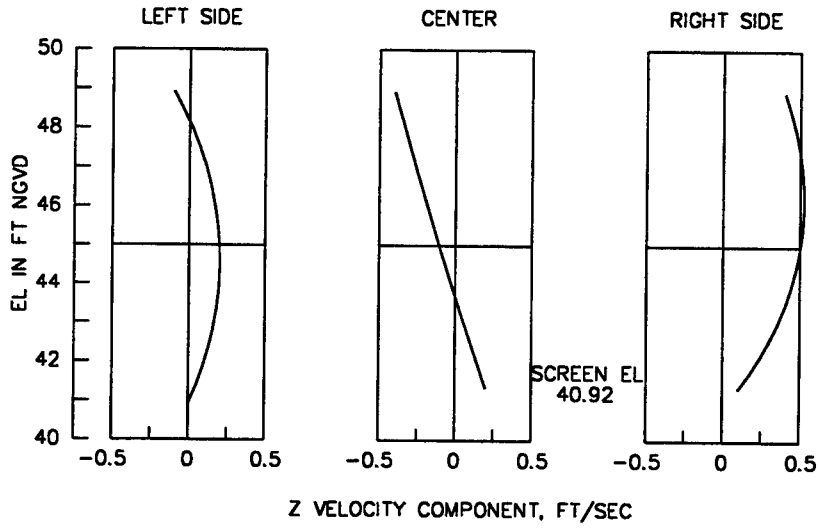

TYPE 3 STILLING BASIN AND TYPE 2 HOOD

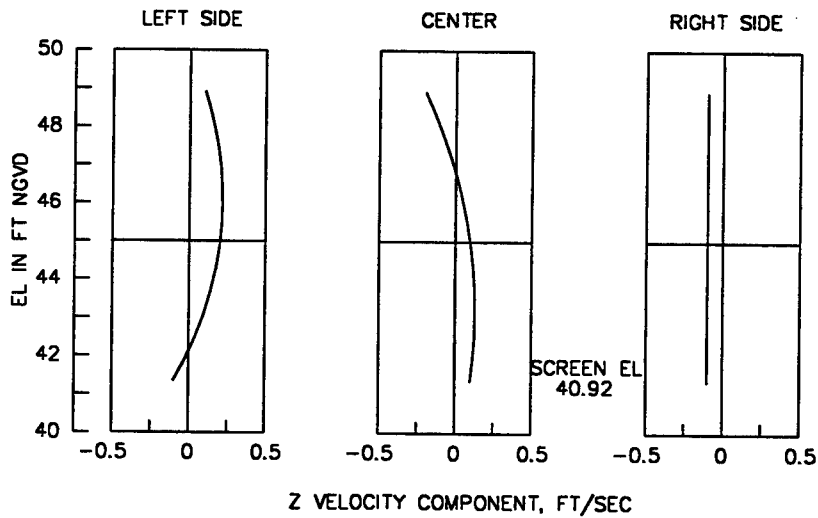

VELOCITY PROFILES
Z-COMPONENT
TYPE 4 AAF SYSTEM
STATION 1, 5 IN. ABOVE SCREEN
DISCHARGE 470 CFS, TW EL 50

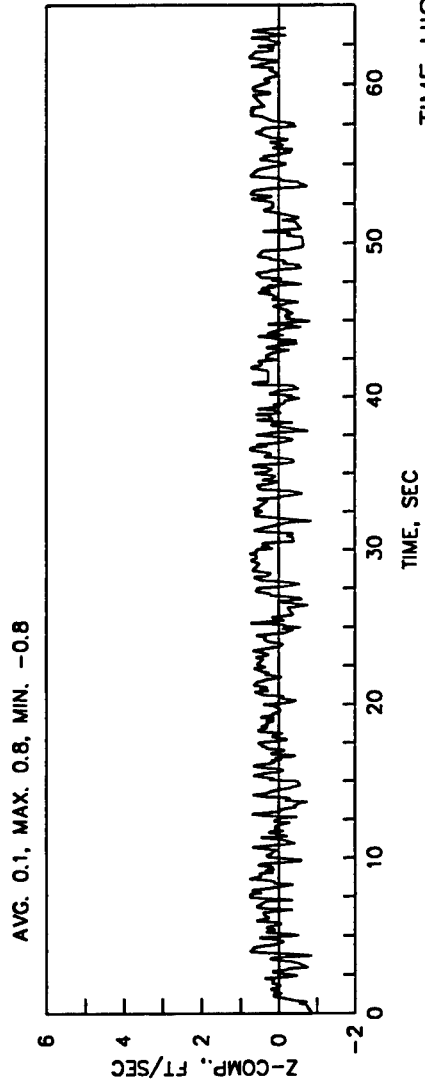
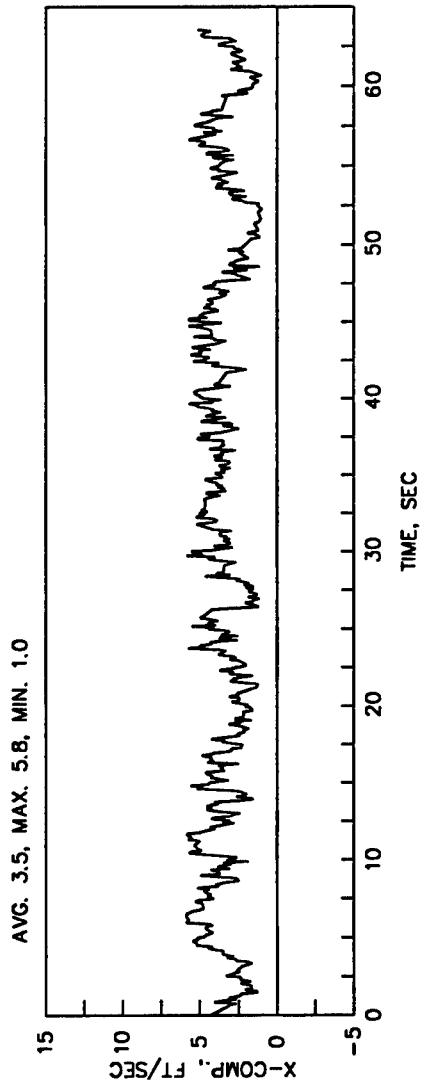

TIME HISTORIES OF VELOCITY
 TYPE 4 AAF SYSTEM
 TYPE 3 DESIGN STILLING BASIN
 TYPE 2 DESIGN HOOD
 STATION 1, 5 IN. ABOVE SCREEN
 DISCHARGE 470 CFS, TW EL 50

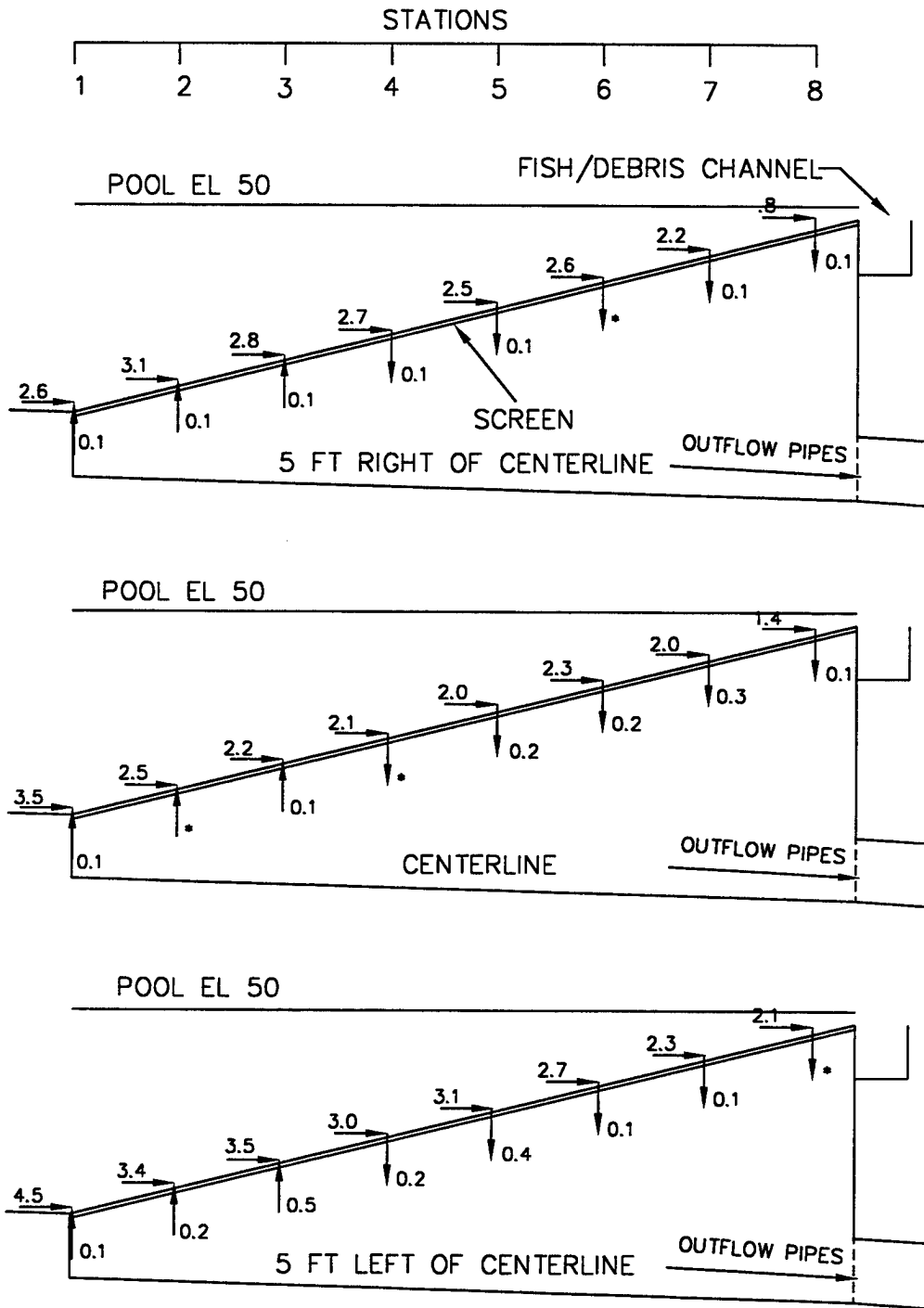

NOTE: STATIONS
5 FT APART
VELOCITIES MEASURED
IN FT/SEC
* VEL. IS < 0.1FT/SEC

AVERAGE VELOCITY X & Z COMPONENTS
TYPE 4 AAF SYSTEM
TYPE 3 STILLING BASIN, TYPE 2 HOOD
TOTAL Q= 470 CFS (3 PIPES OPERATING)
0.42 FT ABOVE SCREEN

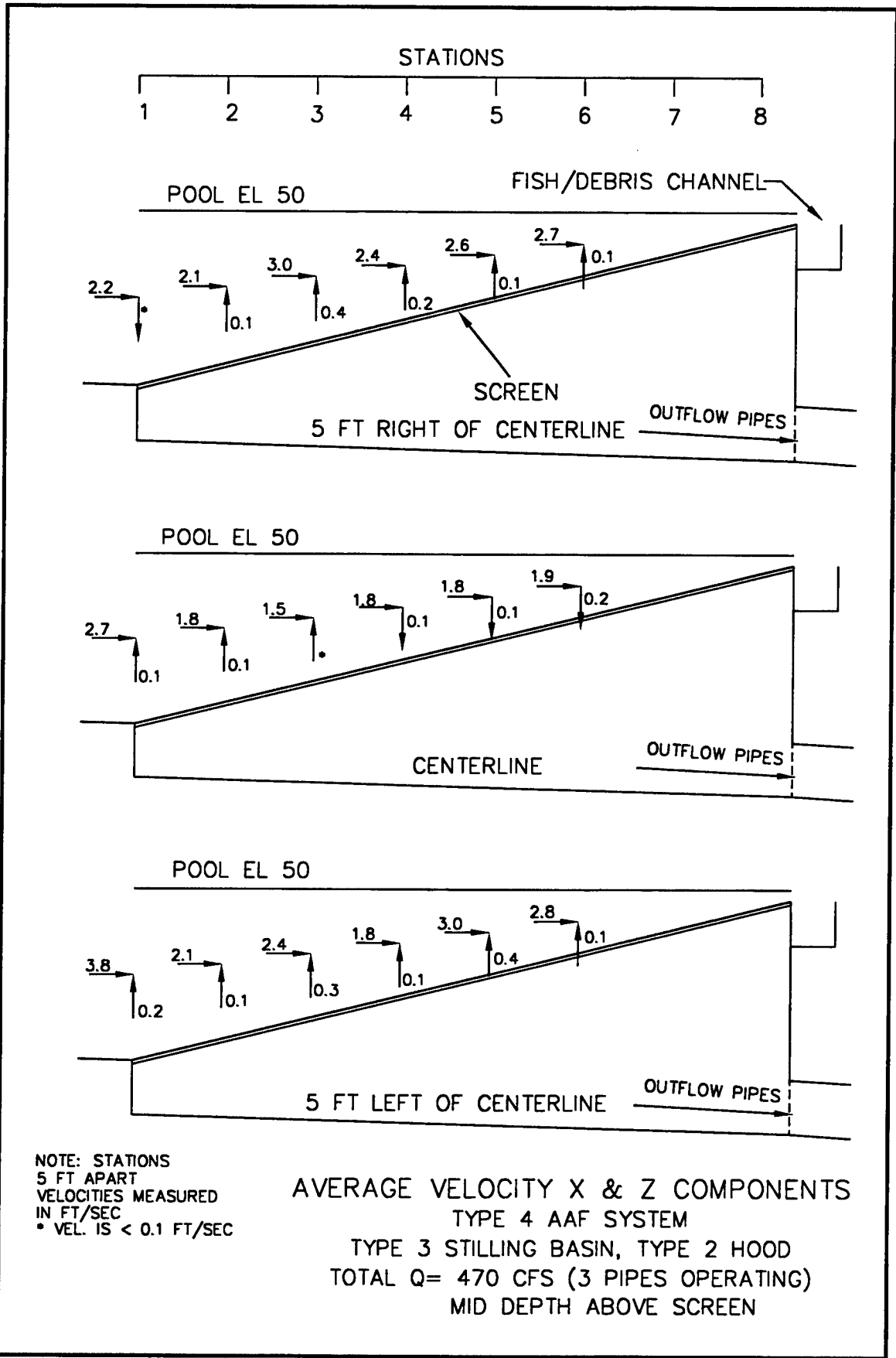
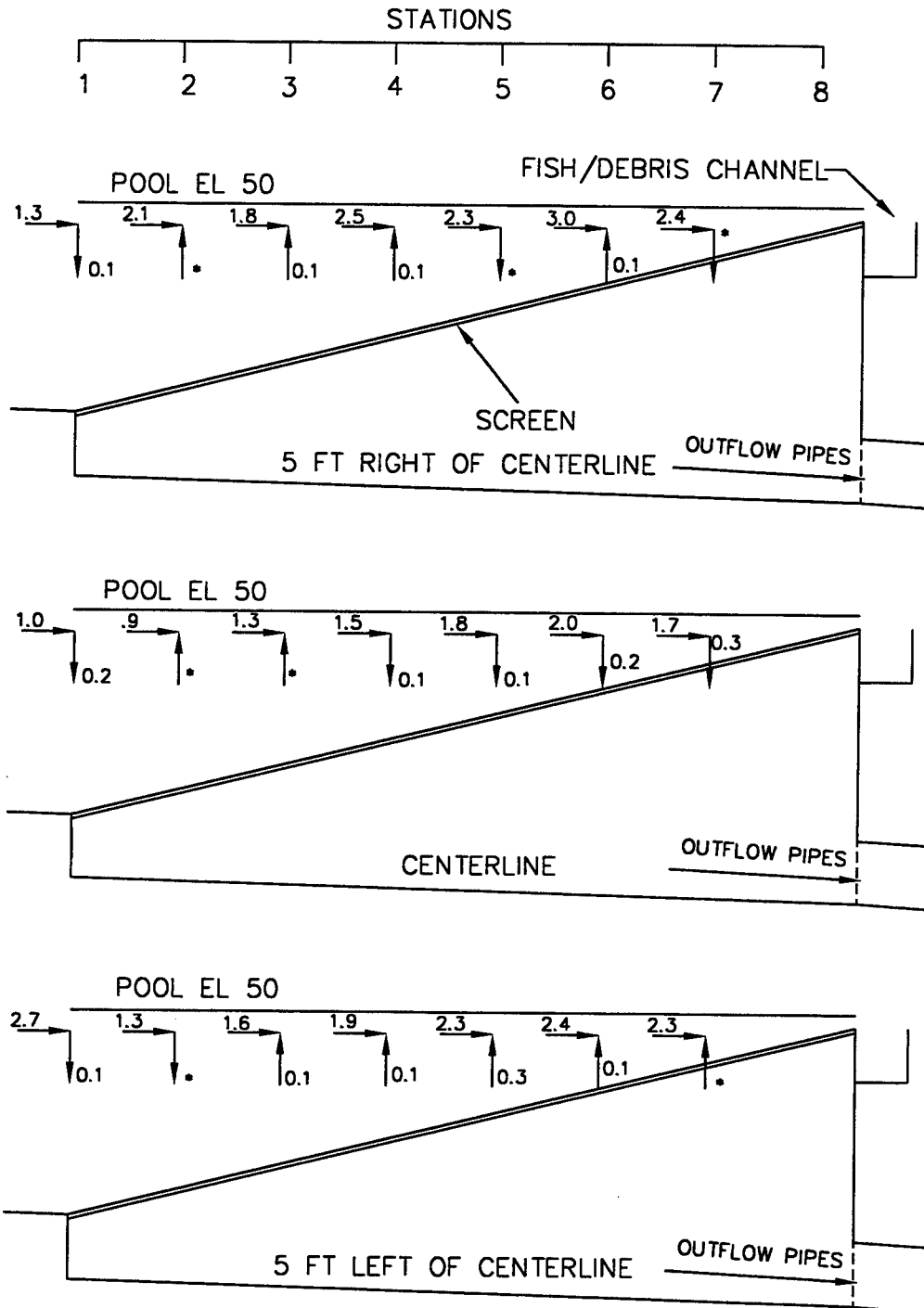

Plate 38



NOTE: STATIONS
5 FT APART
VELOCITIES MEASURED
IN FT/SEC
• VEL. IS <0.1 FT/SEC

AVERAGE VELOCITY X & Z COMPONENTS
TYPE 4 AAF SYSTEM
TYPE 3 STILLING BASIN, TYPE 2 HOOD
TOTAL Q= 470 CFS (3 PIPES OPERATING)
1 FT BELOW SURFACE

REPORT DOCUMENTATION PAGE

Form Approved
OMB No. 0704-0188

Public reporting burden for this collection of information is estimated to average 1 hour per response, including the time for reviewing instructions, searching existing data sources, gathering and maintaining the data needed, and completing and reviewing the collection of information. Send comments regarding this burden estimate or any other aspect of this collection of information, including suggestions for reducing this burden, to Washington Headquarters Services, Directorate for Information Operations and Reports, 1215 Jefferson Davis Highway, Suite 1204, Arlington, VA 22202-4302, and to the Office of Management and Budget, Paperwork Reduction Project (0704-0188), Washington, DC 20503.

1. AGENCY USE ONLY (Leave blank)		2. REPORT DATE September 1998	3. REPORT TYPE AND DATES COVERED Final report	
4. TITLE AND SUBTITLE Model Study of St. Stephen Powerhouse Fish Passage Facilities, Cooper River Rediversion Project, South Carolina			5. FUNDING NUMBERS	
6. AUTHOR(S) John E. Hite, Jr., Thomas E. Murphy, Jr.				
7. PERFORMING ORGANIZATION NAME(S) AND ADDRESS(ES) U.S. Army Engineer Waterways Experiment Station 3909 Halls Ferry Road, Vicksburg, MS 39180-6199			8. PERFORMING ORGANIZATION REPORT NUMBER Technical Report CHL-98-27	
9. SPONSORING/MONITORING AGENCY NAME(S) AND ADDRESS(ES) U.S. Army Engineer District, Charleston P.O. Box 919 Charleston, SC 29402-0919			10. SPONSORING/MONITORING AGENCY REPORT NUMBER	
11. SUPPLEMENTARY NOTES Available from National Technical Information Service, 5285 Port Royal Road, Springfield, VA 22161.				
12a. DISTRIBUTION/AVAILABILITY STATEMENT Approved for public release; distribution is unlimited.			12b. DISTRIBUTION CODE	
13. ABSTRACT (Maximum 200 words) <p>This report documents a model study of the St. Stephen Power Plant, located in Berkely County, South Carolina. A previous model study revealed that the fish lift at the powerhouse could be improved by providing auxiliary attraction flows to the fish entrances. An auxiliary attraction flow (AAF) system was proposed that uses a siphon to obtain the auxiliary attraction water from the reservoir. The model investigations reported herein address the flow conditions at the discharge end of the siphon; the hydraulic aspects of the siphon are not addressed. Three different models were used to evaluate flow conditions at the discharge end of the AAF system. A 1:25-scale model of the St. Stephen powerhouse was used to improve the fish entrance conditions and to evaluate the outlet conditions for the initial AAF system. As the investigations progressed, the design of the siphon discharge system was modified to include downstream fish migration and debris passage.</p>				
14. SUBJECT TERMS Auxiliary attraction flow (AAF) systems Fish lifts St. Stephen Power Plant			15. NUMBER OF PAGES 93	
			16. PRICE CODE	
17. SECURITY CLASSIFICATION OF REPORT UNCLASSIFIED	18. SECURITY CLASSIFICATION OF THIS PAGE UNCLASSIFIED	19. SECURITY CLASSIFICATION OF ABSTRACT	20. LIMITATION OF ABSTRACT	