



THE T-27 "TUCANO" ENGINE
PIPELINE OF THE BRAZILIAN AIR FORCE:
A MANAGERIAL APPROACH

THESIS

Jorge Barros Santos, Major, BAF

AFIT/GLM/LAL/98J-2

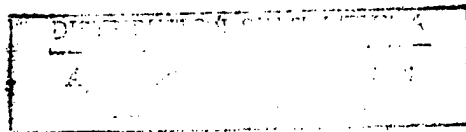

19981009 037

DTIC QUALITY INSPECTED 2

DEPARTMENT OF THE AIR FORCE
AIR UNIVERSITY
AIR FORCE INSTITUTE OF TECHNOLOGY

Wright-Patterson Air Force Base, Ohio

AFIT/GLM/LAL/98J-2

THE T-27 "TUCANO" ENGINE
PIPELINE OF THE BRAZILIAN AIR FORCE:
A MANAGERIAL APPROACH

THESIS

Jorge Barros Santos, Major, BAF

AFIT/GLM/LAL/98J-2

Approved for public release; distribution unlimited

The views expressed in this thesis are those of the author and do not reflect the official policy or position of the Brazilian Air Force, the Brazilian Government, or the Department of Defense and the U.S. Government.

AFIT/GLM/LAL/98J-2

THE T-27 "TUCANO" ENGINE PIPELINE OF THE BRAZILIAN AIR FORCE:
A MANAGERIAL APPROACH

THESIS

Presented to the Faculty of the Graduate School of Logistics and Acquisition Management

of the Air Force Institute of Technology

Air University

Air Education and Training Command

In Partial Fulfillment of the Requirements for the Degree of

Master of Science in Logistics Management

Jorge Barros Santos, B.S.

Major, BAF

June 1998

Approved for public release; distribution unlimited

Acknowledgments

I would like to express my gratitude to Major Chris Burke and Dr. Craig Brandt, for their guidance and support critical for completion of this thesis. Also to my wife, Fatima and my children Ana Carolina, Ana Cláudia and Ana Clara, for their patience and understanding; not forgetting my good friend Lieutenant Fabricio Saito, for his support and companionship. Finally, in memory of my father, Raymundo De Barros Santos, who passed away during the execution of this project.

Jorge Barros Santos

Table of Contents

	Page
Acknowledgements.....	ii
List of Figures.....	vi
List of Tables.....	vii
Abstract.....	viii
I. Introduction.....	1
Chapter Overview.....	1
Background Information.....	1
Problem Definition.....	3
Research Questions.....	4
Investigative Questions.....	5
Limitations.....	5
Research Objectives.....	6
Expected Results.....	7
Summary.....	7
II. Literature Review.....	8
Introduction.....	8
What is a Reparable?.....	8
The United States Air Force Background.....	9
Maintenance Levels on the Brazilian Air Force.....	11
Transportation Modes.....	14
Reparable Pipeline Segments in The Brazilian Air Force.....	16
Bar Code.....	17
Electronic Data Interchange (EDI).....	18
Radio Frequency Identification Tag (RF Tag).....	19
Inductive RF Tags.....	19
Back Scatter.....	20
Two-way.....	21

	Page
Summary.....	21
III. Methodology	23
Introduction	23
Research Design.....	23
Data Collection	25
Description of the T-27 Engine Pipeline	29
Data Analysis	30
Identifying the Bottlenecks.....	30
Expectations	31
Summary.....	31
IV. Results and Analysis.....	32
Introduction	32
Research Findings	32
The Processes	40
The Flightline Segment.....	40
Base Maintenance Segment.....	42
The Retrograde Segment.....	42
The Depot Segment	45
CELMA, The Contractors Flow.....	51
The Distribution Segment.....	51
The Impact of Transportation.....	53
Bottlenecks	56
1. Transportation	56
2. Regulations.....	59
Other Findings.....	60
The BAF T-27 Engine Pipeline Conceptual Model	64
Summary of Results	66

	Page
V. Conclusions and Recommendations	67
Chapter Overview	67
Interpretations and Conclusions.....	67
Suggestions for Further Research	72
Summary of Research.....	72
Appendix A: List of Acronyms and Abbreviations.....	75
Appendix B: Questionnaire.....	77
Appendix C: List of Sample Engines.....	78
Appendix D: U.S. Army Memorandum.....	79
Bibliography.....	82
Vita.....	85

List of Figures

Figure	Page
2-1. Bar Code	18
4-1. Engine Pipeline	33
4-2. Depot Segment	35
4-3. Retrograde Movement	37
4-4. Serviceable Asset Distribution	39
4-5. The Flightline Segment.....	41
4-6. The Base Segment.....	43
4-7. The Retrograde Segment.....	44
4-8. The PAMALS Segment.....	46
4-9. The PAMAAF Segment	47
4-10. The Contractor Segment	48
4-11. The Distribution Segment.....	52
4-12. Repair Cycle Times	54
4-13. Transportation Major Routes	55
4-14. The Conceptual Pipeline	65

List of Tables

Table	Page
2-1. Major Levels of Maintenance	13
4-1. Mode Selection	55
4-2. Variability.	57
4-3. Most Significant Answers.....	61

Abstract

Modern Armed Forces are extremely sensitive to the performance of their support. Fighting a war is absolutely unthinkable without a highly efficient logistic support and management. Studying logistics through the eyes of a pilot that is also a part of the support process make this approach very interesting.

The T-27 is a Brazilian-made aircraft, manufactured by "Empresa Brasileira de Aeronáutica - EMBRAER". The purpose of this study is to describe the processes that take place in the depot repair pipeline of the T-27 Engine. With the objective of identifying any existent bottlenecks and suggests managerial approaches to improve the overall system performance.

The management of reparable assets in the Brazilian Air Force currently prioritizes repair and allocates items to the end-users based on an organizational set of procedures that varies from depot to depot. This diversification or lack of standardization on the local procedures, make the administration of the total process more complicated and difficult.

The study suggests three possible solutions. First, do modification in the processes, with low costs of implementation. Second, technological changes to improve the visibility of the pipeline, particularly on the transportation segment, through the use of bar code readers, radio frequency tags, and electronic data interchange will ease the control of the assets. Third, a reassessment and improvement of current regulations associated with an acquisition of identification and tracking devices.

**THE T-27 "TUCANO" ENGINE PIPELINE OF THE
BRAZILIAN AIR FORCE: A MANAGERIAL APPROACH.**

I - Introduction

Chapter Overview

This research addresses the management of Brazilian Air Force (BAF) reparable assets. This chapter describes the background information, specific problem, research questions, investigative questions, limitations, research objectives, and expected results.

Background Information

The management of reparable assets in the Brazilian Air Force currently prioritizes repair and allocates items to the end-users based on an organizational set of procedures that varies from depot to depot. This diversification or lack of standardization on the local procedures, make the administration of the total process more complicated and difficult. If the decision-makers had a better control of the reparable assets, and could make visible their flow through the pipeline, they would be able to utilize the available resources optimally. This

research addresses a new managerial approach for the Brazilian Air Force reparable pipeline.

Many authors have been trying to present a comprehensive definition of the logistics pipeline, each one a little different from the other. However, it is important to understand that a logistics pipeline must be defined with respect to its organizational context. (12:8). This means that, despite the different definitions of the logistics pipeline, there will be no extreme right or wrong definitions. There will be one, which fits best or the most appropriate for one particular organizational context.

For the objectives of this study, it is helpful to have a good understanding of the conceptual view of a generic pipeline. The generic pipeline's attributes of length, diameter, and volume may be associated with time, rate, and number of assets respectively.

For this study, length equals time, that is, the total time the repair cycle takes, from the removal of the unserviceable item until its return to the end-user. This length includes, for example, transportation, repair time, and order processing time. Diameter equals rate, or the flow of assets through the pipeline, usually in units per day. Volume equals the number of assets.

"Traditionally, military logisticians have believed that as long as the pipeline was full, the mission was being adequately supported" (12:11). However, recent facts have showed that, the BAF cannot afford this approach anymore. Extensive budget reductions have arisen and Brazilian Air Force managers must face this new reality, now and in the future.

Problem Definition

The Brazilian Air Force logistics pipeline is complex and broad; it is beyond the scope of this study. However, if parts of the system are well defined, then a sufficient understanding may be possible towards the overall system. The focus of this study will be on a single aircraft type, the Tucano (T-27), which has been chosen because of its attributes.

The T-27 Tucano is a Brazilian made turboprop trainer, built by "Empresa Brasileira de Aeronautica - EMBRAER". The number of Tucanos in service in the BAF is approximately 150 units, distributed among eight bases. The Tucano is also employed by 14 Air Forces in the world, such as United Kingdom, France, Argentina, Egypt, Colombia, Peru and Paraguay.

The Brazilian Air Force has limited funding to buy and repair the assets required to keep its aircraft flying; consequently the allocation of these limited resources is crucial. The right item needs to be at the right place at the right time. The BAF cannot afford to have either expensive components waiting at the warehouses, or non-mission capable aircraft due to the lack of serviceable parts.

The BAF needs to improve its reparable asset management practices to improve the overall system performance. The problem is that the BAF is having non-mission capable aircraft due to the lack of serviceable reparable assets.

Research Questions

The broader question is how can the Brazilian Air Force improve its T-27 reparable management practices? This question has been refocused from the many reparables of the Tucano to just the engine for two reasons. First, it narrows the scope of the research and still provides an excellent representation of the process. Second, because of the high value of an engine, minor improvements in the pipeline may represent reductions in the number of engines

and consequently a significant economy of resources for the BAF.

The problem associated with improvements on the T-27 reparable management practices is that no definition or model of this pipeline exists.

Investigative Questions

This study, in order to provide answers to the above question, will address the following investigative questions:

1. What segments constitute the T-27 Tucano engine reparable pipeline?
2. What processes take place in each major segment of the pipeline?
3. How are the major segments linked together?
4. What are the system bottlenecks, if any?
5. Where are the system bottlenecks located, if anywhere?

Limitations

The data collection is a constraint, which necessitates that this study be limited to a segment of the overall system. Also, the study is based on the assumption of peacetime operations, so that, the demand for the item

being studied is independent and stationary; inventory policies are dependent on a continuous review system, and order replacements occur on one-for-one basis.

Another important issue is the nature of the data to be collected. Classified information is beyond the scope of this study. Consequently, whenever this research encounters a sensitive datum, it shall not be disclosed unless expressly authorized by BAF or USAF. Otherwise, it will be disregarded.

As previously stated, the BAF logistics pipeline is too broad for this research. Hence, the pipeline segment this research studies will be limited to a single aircraft type, the T-27, and specifically, to the T-27 engine.

Research Objectives

The objective of this research is to describe the process and identify any bottlenecks of the logistics pipeline of the T-27 engine and suggest managerial approaches to improve the overall system performance, such as, evaluating the impact of improvements on transportation management in the pipeline.

Expected Results

A better understanding of the T-27 reparable pipeline is expected, as well as some improvement on the overall reparable system management practices such as reduction of the pipeline, better responsiveness, and increased aircraft availability. This improvement means reduction of the number of reparable assets flowing through the pipeline, less time to complete the repair-cycle, and the most important, reduction of the total cost of the process.

Summary

In this chapter some background information was given. The problem addressed by this study was defined, and the research and investigative questions were placed, as well as the objective and the expected results of this work.

In the next chapter, the meaning of the term reparable will be discussed briefly. A quick review of the United States Air Force (USAF) background, the maintenance levels on the Brazilian Air Force, and transportation modes. Also the reparable pipeline segments in the Brazilian Air Force (BAF). Finally the concepts and explanations of bar codes, electronic data interchange and radio frequency tags will be presented.

II – Literature Review

Introduction

A literature review was performed pertaining to the reparable pipeline segment of the Brazilian Air Force. Its purpose is to define the reparable pipeline. It has been found that no previous research provided details concerning the BAF logistics pipeline.

What is a Reparable?

A reparable asset is an item so designed that it is capable of being repaired after it breaks. In other words, it is an item that can be reconditioned or economically repaired for reuse when it becomes unserviceable. Typically complex, reparables are very expensive, with long procurement lead-times, which makes their repair a cost-effective alternative. Examples of reparables are radios, landing gears, "black boxes", and engines. Reparables are also known as recoverables, exchangeables, and repair cycle assets. A repair policy may dictate that an item should be designed to be non-repairable, partially repairable, or fully repairable. It is important to understand that a reparable asset is a repairable or partially repairable item which repair is economically viable. (12:9)

A non-reparable item is generally one with a relatively low replacement cost that is discarded when a failure occurs. No repair is accomplished; the failed item is disposed of and replaced by a spare.

A partially reparable item is generally a modular assembly and contains certain components that can be removed, replaced and discarded, while other components are considered economically reparable.

A fully reparable item is considered totally reparable at one or more maintenance levels, and generally requires specialized facilities, support and test equipment, specialized skills, technical data, spare and repair parts inventory.

The United States Air Force Background

Bond and Ruth (1989) developed a conceptual model of the USAF logistics pipeline (5:171). They divided the pipeline into four major subsystems, and identified transportation as "a linkage that directly influence the efficiency and effectiveness of materiel flows". Their study became a useful stepping stone for continued research into reparable flow through the USAF logistics pipeline.

The ultimate question is: What can the average logistician get out of this study? Perhaps most of all, as in the case of the authors of this study, logisticians can gain a fundamental knowledge of how reparable assets flow through the overall pipeline. The conceptual model of the various processes and activities involved within each subsystem eliminates some of the "unknowns" or "black holes" into which reparable assets flow, and some of the hidden actions required to make the system work. (5:214)

Kettner and Wheatley (1991) studied Bond and Ruth's (1989) conceptual model to analyze the pipeline's depot-level reparable section. They identified four primary segments: base processing, in-transit, supply to maintenance, and serviceable maintenance.

Despite the fact that BAF and USAF are different in many ways, the research of Bond and Ruth (1989), and Kettner and Wheatley (1991) is also valuable to the BAF. Their approach on the analysis of the USAF logistics pipeline showed the necessity of a meticulous study of the pipeline and its components to understand and analyze their relationships.

The USAF experience during Desert Storm brought some interesting points to be reviewed. Gunselman's (1991) article "Documentary on Desert Shield/Storm Supply Support" attempts to capture the essence of supply support provided

to USAF units deployed to the area of responsibility during the Persian Gulf War effort. It also presents the solutions to the problems with the reparable retrograde segment.

The return of reparable spares became important since follow-on support calls for the repair and return of reparable assets. "To alert transportation of priority Air Force cargo, Air Force project code 672, nicknamed PACER RETURN, was developed to alert transportation of priority retrograde" (11:14).

Many lessons learned evolved from the Desert Storm Operation. Gunselman (1991) presents several approaches in his article, and among them it is found that *visibility over retrograde movement must be obtained and high priority cargo must be identified for expeditious movement.* USAF Solution: field systems such as the Cargo Movement Operations System (CMOS) and the Air Force Logistics Information File (AFLIF) which can identify where an asset is in the transportation system.

Maintenance Levels on the Brazilian Air Force

The maintenance on the BAF may be classified as organizational level, base or intermediate level, and depot

level. The overall structure of the BAF maintenance at the organic and base levels is described on "Norma de Serviços do Ministério da Aeronáutica (NSMA) 65-2 : Manutenção Nível Orgânico e Base" (16:12). That is, the NSMA means Ministry of Aeronautics' Norms of Services , which is a series of instructions for internal services and procedures. The title is "Manutenção Nível Orgânico e Base", that means Organic and Base Maintenance Levels.

The depot level maintenance is described on "NSMA 65-3 : Manutenção Nível Parque" (17:14), that means Depot Level Maintenance.

The concepts in the "NSMA 65-2 and 65-3" are not different from Blanchard's. To avoid a transcription of the definitions written in Portuguese, it has been found that, for this study purposes, a good representation of the BAF maintenance levels is the one described in Blanchard's book.

The organizational maintenance is performed at the operational flight line. In general, these maintenance tasks are performed by the user, personnel usually involved with the operation and use of equipment. Maintenance at this level is limited to periodic checks of equipment performance, visual inspections, cleaning of equipment,

servicing, external adjustments, and the removal and replacement of some components. See table 2-1.

Base level maintenance is performed by mobile, semi-mobile, and or fixed installations and equipment. End items may be repaired by the removal and replacement of major modules, assemblies, or piece parts. At this maintenance level personnel are usually more skilled and better equipped than those at the organizational level (1:31).

Table 2-1 Major Levels of Maintenance

Criteria	Organizational Maintenance	Intermediate Maintenance		Depot Maintenance
		Mobile or semimobile units	Fixed units	
Done where?	At the operational site or wherever the prime equipment is located	Truck, van, portable shelter, or equivalent	Fixed field shop	Depot facility ----- Specialized repair activity, or manufacturer's plant
Done by whom?		System/equipment operating personnel (low maint. skills)	Personnel assigned to mobile, semimobile, or fixed units (intermediate maintenance skills)	Depot facility personnel or manufacturer's production personnel (mix of intermediate fabrications skills and high maintenance skills)
On whose equipment?	Using organization's equipment	Equipment owned by using organization		
Type of work accomplished?	Visual inspection Operational checkout Minor servicing External adjustments Removal and replacement of some components	Detailed inspection and system checkout Major servicing Major equipment repair and modifications Complicated adjustments Limited calibration Overload from organizational level of maintenance	Complicated factory adjustments Complex equipments repairs and modifications Overhaul and rebuild Detailed calibration Supply support Overload from intermediate level of maintenance	

Adapted from Blanchard, B. S. (1:31)

Depot level maintenance constitutes the highest type of maintenance, and supports the accomplishments of tasks above and beyond the capabilities available at the organizational and base levels. Also, in the BAF structure, the depots have responsibilities similar to the USAF "System Program Office (SPO)" for a particular aircraft system, called by BAF a project.

After the production phase of the Brazilian acquisition process, the depot manages the operational support, maintenance, modifications and disposal of the system, in coordination with the user. The depot formally meets the operator, to discuss operational issues, at least twice a year, and besides that, whenever an operational issue requires the depot support and involvement.

Transportation Modes

Logistics involves the movement of products (raw materials, parts, suppliers, and finished goods) from point-of-origin to point-of-consumption. Not only does transportation add place value or utility to the pipeline by moving material across distances, it also creates time utility by controlling how fast a product moves from one point to another.

Transportation requirements include the movement of human and material resources, in support of both operational and maintenance activities, from one location to another. When evaluating the effectiveness of transportation, one must deal with such factors as: (3:486)

1. Transportation route
2. Transportation capability or capacity (modes of transportation, volume of goods transported, quantity of loads)
3. Transportation time (short-haul versus long-haul time, mean delivery time, and so on)
4. Transportation cost (cost per shipment, cost of transportation per mile, cost of packaging and handling)

The BAF most used modes of transportation are ground and air. Ground transportation in Brazil is flexible and convenient. The air transportation has the advantages of speed, frequent service to major cities, and overnight service to almost any point in the country (with the exception of remote areas on the Amazonian region).

To support reparable asset movement through the logistics pipeline, the BAF maintains regular lines of air

and ground transportation modes. In both cases, ground and air, the commercial or civilian industry segment, is also used. However, the priority is given to the military transportation system, due to budget constraints. The commercial segment is mostly used for small items, and basically, emergencies.

The military segment, utilizes the BAF cargo fleet, basically composed of C-130's Hercules, C-115's Buffalo, C-135's Boeing, C-91's AVRO, and C-95's Bandeirante; and also the BAF truck fleet. The transport lines schedules are regulated by BAF and are adapted accordingly to BAF current needs, and are beyond the scope of this study.

Reparable Pipeline Segments in The Brazilian Air Force

There is no document that addresses specifically the reparable logistic pipeline in the BAF. There is a set of "Instrução do Ministério da Aeronáutica (IMA), that means Ministry of Aeronautics Instruction, which is a series of documents that formally establish the guidelines and procedures to be executed by the BAF organizations.

The IMA 65-17 "Programa de Manutenção de Reparáveis" (18:14), that means Reparables Maintenance Program, is the document that provides the overall guidance to the

management of the reparables in the BAF. This document addresses the flow of reparable items, and identifies four major areas which, are User, which encompasses the organic and base levels; supporter, which encompasses depot and contractor; repair cycle; and distribution. This document is primarily concerned with the establishment of basic rules for the scheduling and the demand forecast of the reparable asset, and not with the identification, visibility and control of the items. The reparable pipeline is not clearly defined and asset tracking is vaguely addressed.

Bar Code

Bar codes are a series of lines interpreted as numbers based on their width and spacing (see Figure 2-1).

Bar code readers are readers of formatted input; in other words, they read text specially formatted for the device in use (bar code reader). These devices support passive data input, allowing them to capture large amounts of data.

Bar codes readers capture data quickly, easily and relatively accurately. Bar codes have been intensely used by manufacturers and suppliers to input data about inventory. This intense utilization is due to the ability

of Bar Code to save time on the identification of inventory items, reduce employee errors handling inventory information and eases the tracking of in-transit inventory (9, 152).

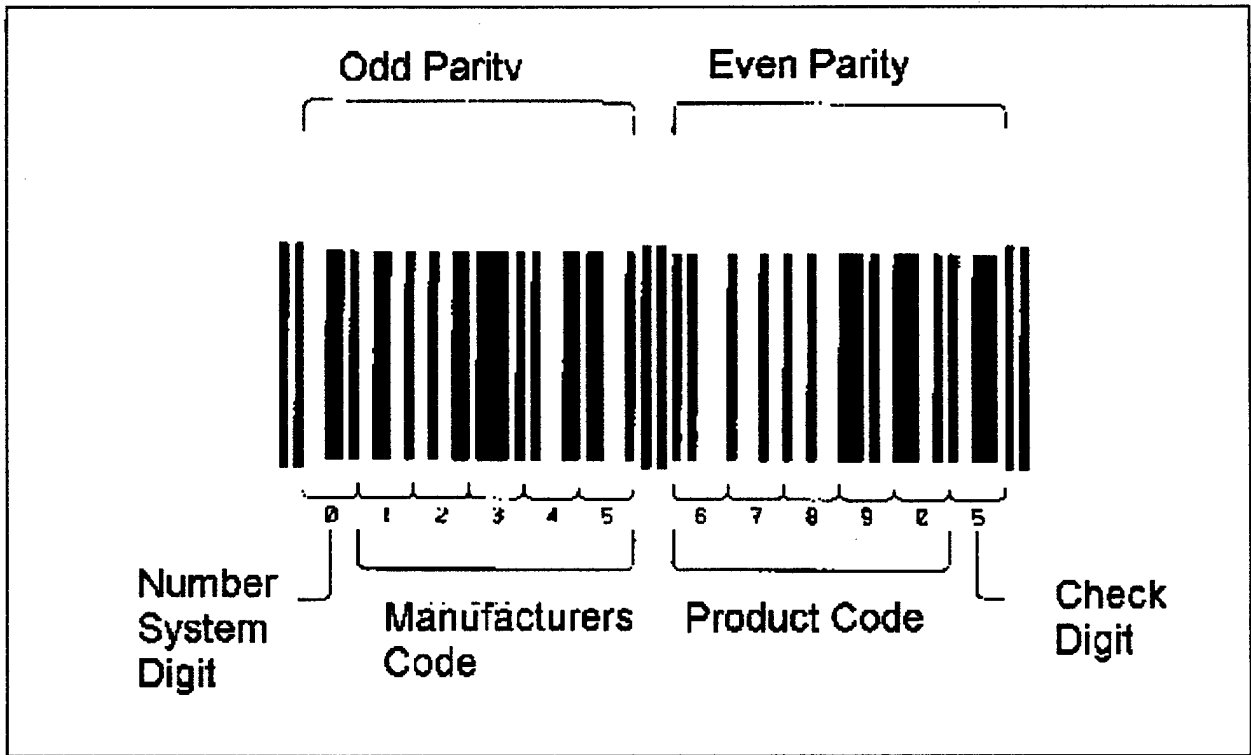

Figure 2-1 Bar Code (As adapted from Glaskowsky et al. page 302)

Electronic Data Interchange (EDI)

Electronic data interchange refers to the exchange of data between two business organizations using a standard electronic format. Companies routinely exchange purchase orders, invoices, shipping notices, and checks using EDI.

The system also supports inventory tracking and communication between headquarters and company's warehouses and sales offices.

Two recent studies suggested that most companies implement EDI to improve customer service, reduce errors, lowers inventory levels, and form tighter strategic alliances with suppliers and customers. (Gordon 245)

Radio Frequency Identification Tag (RF Tag)

RF Tags are used to identify fish, livestock, pets, and products; provide inventory control and theft prevention; automation production systems; allow access to buildings and parking areas, collect tolls and automate traffic; access vehicles and provide theft prevention. RF Tags generally fall into three broad categories: inductive RF tags; back scatter; and two-way.

Inductive RF Tags

Inductive tags are energized by passing through an energizing field generated by one interrogator. The tag resonates at the frequency of the field causing a disruption of the field. These tags have minimal information storage capabilities. Typical read ranges are less than 10 feet.

Typical applications for inductive tags are electronic article surveillance (EAS); anti-theft systems; access control systems; personal identifications systems; wild life management; pet identification; product identification; vehicle access & security.

Back Scatter

Back scatter tags may be either passive (no battery) or active (battery powered). They reflect a small portion of the RF energy of the interrogator. The reflected signal is modulated or encoded with information stored in the tag.

Passive back scatter tags convert a portion of the RF energy from the tag reader/interrogator to power the transponder. The tag generates a data stream comprised of a clock signal and the data stored in the tag. Back scatter tags are capable of being programmed with varying amounts of information. Some tags may be re-programmed by a reader others have the ability to store additional data from readers to their internal memory. Typical applications for back scatter tags are toll collection; traffic management systems; inter-modal container management; asset tracking; rail car identification; and rail control systems.

Two-way

Two-way tags are active tags that incorporate a miniature transmitter and/or receiver. The tag may be polled or transmit freely. Data may be read only or programmed by the interrogator. These are the most expensive type tags.

Typical applications for two-way tags are traffic management systems; manufacturing process control; waste management, and high value asset control.

The United States Army is currently implementing the utilization of RF Tags, and as transcribed from an United States Army document:

RF tags are expendable, recoverable and reusable property and do not require property book accounting. However, each tag costs the Government approximately \$200.00 and the logistics system is utilizing a fixed quantity of these tags. (Appendix D)

Summary

This chapter performed a literature review of the reparable pipeline segment of the Brazilian Air Force and found that the reparable pipeline is not clearly defined and asset tracking is vaguely addressed. The term reparable was described, as it is understood in this study.

The USAF background is quickly reviewed, and its solution to similar troubles with reparable retrograde movement. The Brazilian Air Force approach to the maintenance levels is also discussed. Bar code, electronic data interchange and radio frequency tags are defined and briefly discussed. In the next chapter the methodology applied in this study will be presented.

III - Methodology

Introduction

The purpose of this chapter is to describe the procedures followed in this study. It is important that a scientific method be used while conducting this research. Due to the nature of the problem, it has been found that an exploratory study is most appropriate.

Exploration is particularly useful when researchers lack a clear idea of the problems they will meet during the study. Through exploration the researchers develop the concepts more clearly, establish priorities, and improve the final research design.
(6:117)

Thus, it has also been found that a qualitative approach is required since this research is primarily concerned with a process rather than outcomes or products, and that the researcher is the primary instrument for data collection and analysis.

Research Design

This research is divided into four major parts, to be performed in sequence. The first part consists of a data collection, which will analyze the available documentation

related to BAF reparable management and logistics pipelines. Also, it will study the most commonly used management approaches to the reparable pipeline. The objective is to understand the basic concepts, flow of materials, and the logistics pipeline structure. Books, papers, and BAF and Department of Defense (DoD) manuals will be the principal references for this task.

The data collection consists of an in-depth interview (conversational rather than structured) and a questionnaire (Appendix B). The objective is to become familiar with the characteristics and elements related to the operation and support of the T-27. Maintenance plans, service bulletins, and records from maintenance, supply, operational sections, and again, personal interviews and the answers obtained from the questionnaire, will provide the information for this work.

The second part of this study consists of the description of the T-27 reparable pipeline. Based on the information obtained throughout part one of this study, data collection, an appropriate conceptual model of the T-27 reparable pipeline will be constructed.

The third part is a data analysis of the current T-27 engine pipeline, based on a comparison between the "what

is" and the "what should be". As previously stated, the quality and quantity of available data will dictate the appropriate analytical techniques.

The fourth part encompasses the identification of the bottlenecks, if any, of the BAF logistic pipeline; identification of alternatives; determine the criteria to assess the alternatives, and the formulation of recommendations to improve the overall process performance.

Data Collection

"The first step in an exploratory study is a search of the secondary literature" (6:59).

The data collection was divided into two distinct parts. The first part consists of an analysis of the available documentation related to BAF reparables management. BAF publications will be used to gather information on BAF logistics pipelines and flow of materials.

The second part, probably the most important, consists of an in-depth interviewing and observations of the personnel involved on the activities of interest, with the objective of answering the questions: who does what, when and how?

Observation is found in almost all research studies, at least at the exploratory stage.
(6:334)

Data relative to at least 30 engines will be collected. The following information was be obtained: the date of removal from the aircraft, transportation times from user installations to the depots and contractors, time spent at repair facilities, and transportation times from contractors and depots to user.

Visits were scheduled to four BAF units and one contractor:

1. "Academia da Força Aérea - AFA", the largest Tucano operator, where data related to activities on base level pipeline were obtained.
2. "Parque de Material Aeronáutico de Lagoa Santa - PAMALS", the T-27 depot, where data related to the aircraft depot level pipeline was obtained.
3. "Parque de Material Aeronáutico dos Afonsos - PAMAAF", the data related to the engine depot level pipeline was verified.
4. "Depósito de Aeronáutica do Rio de Janeiro - DARJ", responsible for surface transportation, where information about reparable and specifically, about engine transportation, were collected.

5. "Companhia Eletro-Mecânica - CELMA", the contractor that also provides depot level maintenance to the engine and is part of the pipeline. The CELMA internal process was studied.

The questions contained in the questionnaire and that were posed to these organizations relate specifically to their responsibilities and how they are affected by the activities of others within the system.

There were made 49 interviews at each unit involved at least five people were interviewed, according to their function and specialty.

a) At the user level the personnel in charge of the following positions were interviewed:

1. Squadron Maintenance Officer
2. NCO in charge of the Maintenance Section
3. NCO in charge of the Engine Maintenance Team
4. NCO Engine Maintenance Inspector
5. NCO, Engine Maintenance Performer

b) At the base level the personnel in charge of the following positions were interviewed:

1. Maintenance and Supply Squadron, Commanding Officer

2. Maintenance and Supply Squadron, Maintenance Officer
3. Maintenance and Supply Squadron, Supply Officer
4. NCO in charge of the Maintenance Section
5. NCO in charge of the Supply Section
6. NCO in charge of the Engine Shop
7. NCO, Engine Shop Maintenance Performer
8. Transportation Officer
9. Transportation NCO
10. NCO, Planning and Documentation Section

c) At the depot level the personnel in charge of the following positions were interviewed:

1. Technical Department Head
2. Reparables Division Head
3. Engine Maintenance Section Head
4. Supply Section Head
5. NCO in charge of the Supply Section
6. NCO in charge of the Engine Shop
7. NCO, Engine Shop Maintenance Performer
8. Transportation Officer
9. Transportation NCO
10. Engineering Section Head
11. NCO, Planning and Documentation Section

12. Contracting Officer

d) At CELMA personnel in charge of the following positions were interviewed:

1. Technical Department Head
2. T-27 Engine Project Manager
3. Engine Shop Manager
4. COMFIREM Head
5. NCO, COMFIREM

e) At DARJ personnel in charge of the following positions were interviewed:

1. Transportation Head
2. Planning
3. Coordinator
4. Vehicle Dispatcher
5. Truck Driver

Description of the T-27 Engine Pipeline

The second part of this study consists of the description of the T-27 engine pipeline. From the collection of information within the literature review, observation, interviews and questionnaire, a model will be developed. The model will be a general descriptive flow chart for reparable items (engines), moving through the

pipeline, with emphasis on the description of the major segments: flightline, base, retrograde, depot and distribution segments.

Data Analysis

The third part is a data analysis of the current T-27 engine pipeline, data analysis of the current T-27 engine pipeline, based on a comparison between the "what is" and the "what should be". As previously stated, the quality and quantity of available data dictate the appropriate analytical techniques.

Identifying the Bottlenecks

Comparing the conceptual and the "real world" pipelines will make it possible to compare the "should be" with the "what is". From this point it will be possible to identify the "bottlenecks", in other words, the spots that are working as constraints to the movement of the reparables through the pipeline. Also, identifying points where enhancements can be made to improve the overall pipeline.

Expectations

It is expected that within the analysis of the model, a better understanding of the process will be obtained. A thorough understanding of the process would make possible improvements on the overall system management.

Summary

In this chapter, the study methodology was introduced. A research design is presented, the first step consisting of the data collection, followed by a description of the T-27 reparable pipeline, a data analysis and finally, the author expectations.

In the next chapter the results and answers to the investigative questions will be provided, as well as the diagrams of T-27 conceptual reparable pipeline.

IV - Results and Analysis

Introduction

This chapter presents the results and analysis of the data collected on the previous phases of this study and an analysis of these results.

Research Findings

The literature review and, most importantly, the field interviews, were used as the basis for answering the investigative questions first presented in chapter one.

After a satisfactory model of the T-27 engine pipeline is developed the next step will be an analysis of the interviews with those who actually worked in many segments of the pipeline, and an analysis of the facts they presented during the interviews.

It should be noted that this conceptual model is intended to represent the T-27 Tucano engine reparable pipeline from an Air Force perspective. Using the basic model shown in Figure 4-1, the pipeline was developed combining pipelines drawn from previous USAF research, like Kettner and Wheatley, and Bond and Ruth. This approach was the key to developing this BAF basic model. However, due

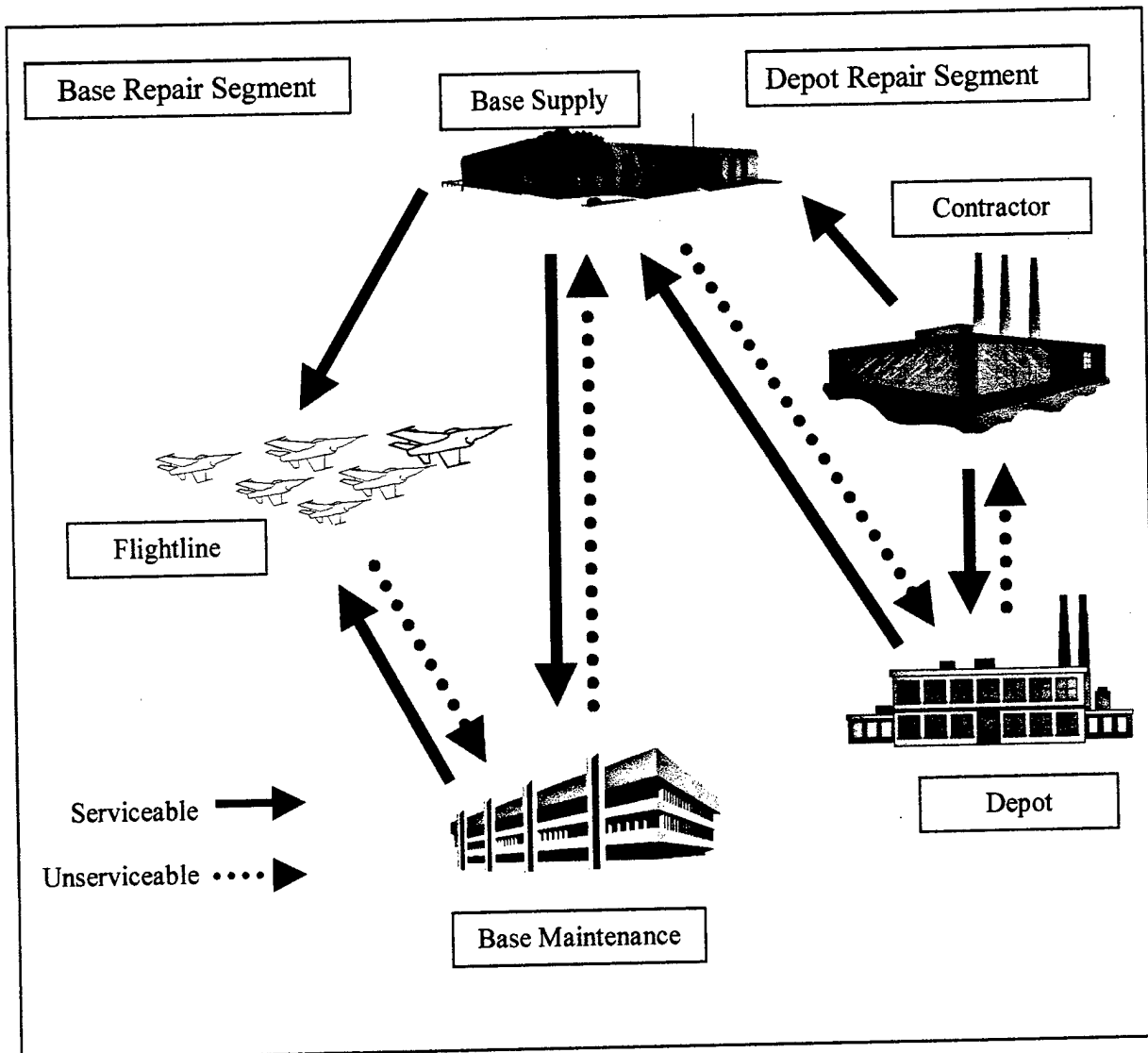

Figure 4-1 Engine Pipeline

to the nature of the data, information like, number of bases, number of engines and distances are not available.

An engine fails at the flightline, a maintenance team evaluates the failure and if it is not possible to repair on the flightline, the engine is sent to the base

maintenance facilities. At this level the engine will be analyzed. If the repair is possible it will be repaired and sent back to the flightline, if still needed, or to base supply.

If the repair is not feasible or not authorized at base level, the engine will be sent to the depot through the base supply system.

At the depot, the engine may be repaired locally at the depot shop or may be sent to a contractor, depending on the extension of the required repairs and the availability of manpower to perform the repair. After the repair is performed, at the depot or at the contractor facilities, the engine is serviceable and returned to depot supply. If the need for one engine still exists, it will be sent to the requestor base.

The base repair segment encompasses the actions taken by the user, at the flightline, at the base maintenance back shops and also at the base supply.

The depot repair segment (represented on Figure 4-2) for this study has been divided on three distinct parts: PAMALS, PAMAAF and CELMA. Where PAMALS stands for "Parque de Material Aeronáutico de Lagoa Santa", this depot is the organization of the Brazilian Air Force which is

responsible for the T-27 Tucano Aircraft. Among other issues, the PAMALS performs and controls all major maintenance tasks on the T-27 fleet.

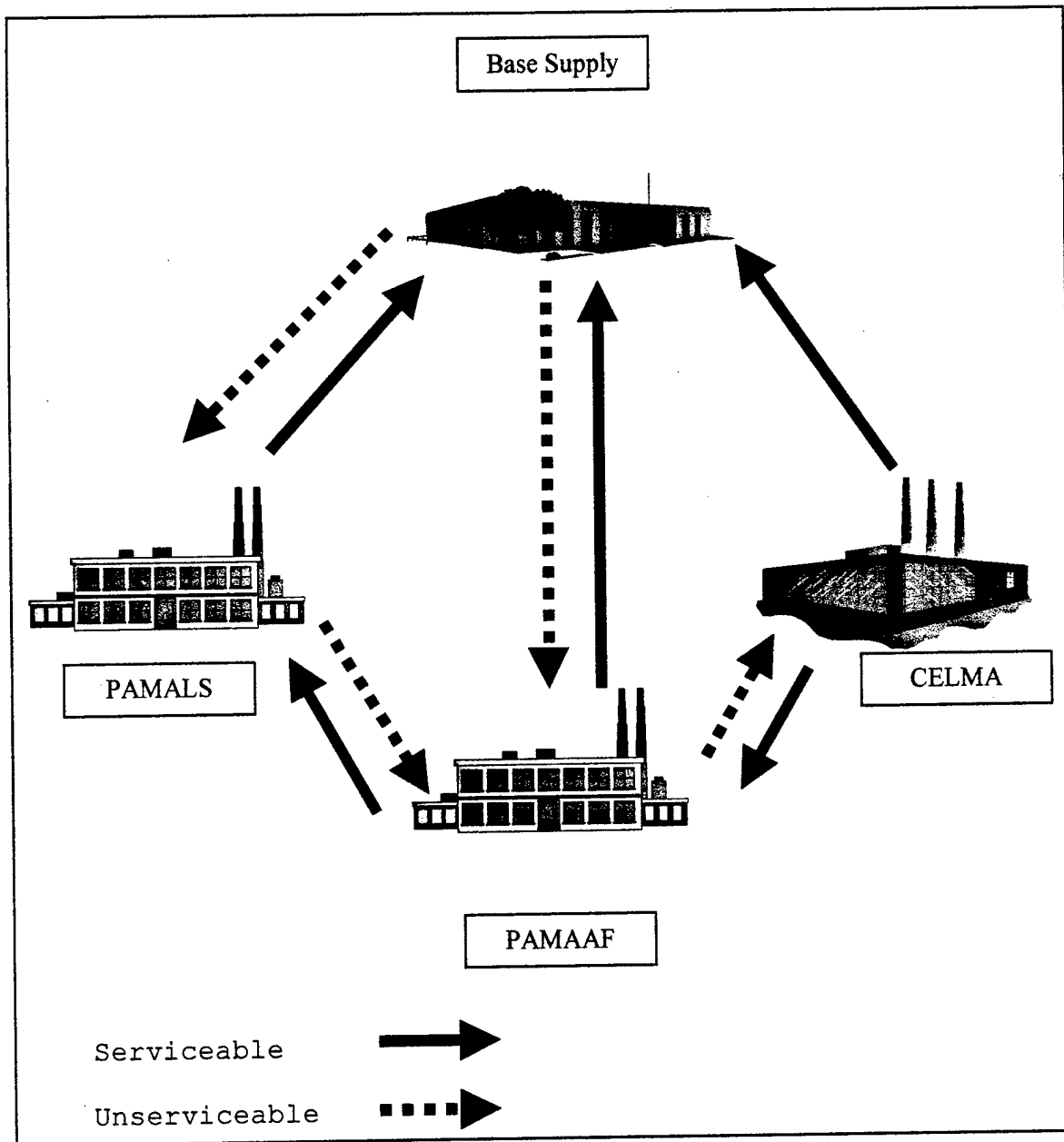

Figure 4-2 Depot Segment

PAMAAF, "Parque de Material Aeronáutico dos Afonsos", the engine's depot, is the organization of the Brazilian Air Force, which is responsible for the T-27 Tucano Engine. CELMA, "Companhia Eletro-Mecânica", is the BAF main contractor performing engine heavy maintenance.

Depot segment PAMALS, is the first entrance for unserviceable engines. Usually PAMALS receives the T-27 aircraft for scheduled major maintenance services. For this reason, many engines expected at PAMAAF for scheduled maintenance are received with the aircraft at PAMALS, which has developed a standardized procedure on these cases. If the engine being received is serviceable and is needed somewhere else, it is shipped promptly. Otherwise it remains in stock at PAMALS or as directed by PAMAAF. If the engine is unserviceable and requires major maintenance, it is shipped to PAMAAF, because PAMALS does not have the capability to perform major repair on the engines. Basically, the contractor (CELMA) is involved in the process in two cases: first, when the repair needed is beyond the technical capability of the PAMAAF. Second, when the capacity of the depot engine shop is the constraint. In this second case, there is no specific criterion to define which engine goes where.

The segment PAMAAF reflects the T-27 engine depot repair process, which is made at PAMAAF and at the contractor's grounds, at CELMA.

The retrograde segment is represented on Figure 4-3 as a square dotted arrow, and it generically represents all actions taken at both base, and depot levels, to bring the engine to repair.

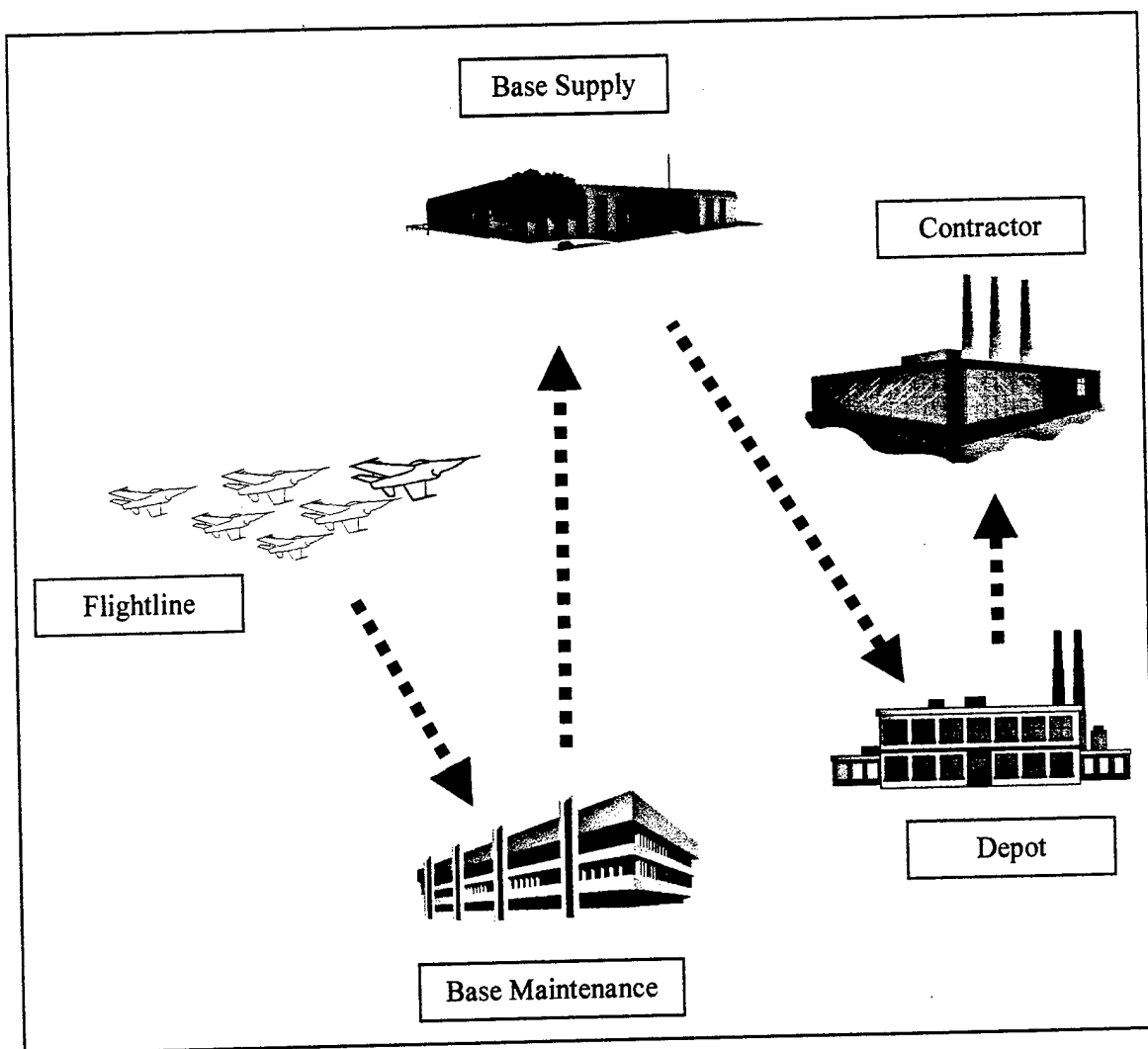

Figure 4-3 Retrograde Movement

The distribution segment is represented on Figure 4-4 as a black continuous arrow, and it generically represents all actions taken at both depot level and base level to bring the engine to the user. Actually, the distribution is performed not directly from the contractor to base supply, as the arrow indicates, (it means rather the flow of the pipeline). The return of an engine from the contractor is performed through a commission, "Comissão de Fiscalização e Recebimento de Material - COMFIREM" located at the contractor's facilities, constituted of BAF personnel to control and receive materials and services provided by the contractor. Among other issues, this commission is responsible for managing the engines owned by BAF being repaired at the contractors' grounds. Usually this commission is administratively related to PAMAAF, and exchanges information with the depot regarding the engines, directing the serviceable engines leaving the contractor, accordingly to the priority established by PAMAAF. The COMFIREM is also responsible for verifying that all the required repairs were performed, all service bulletins were incorporated.

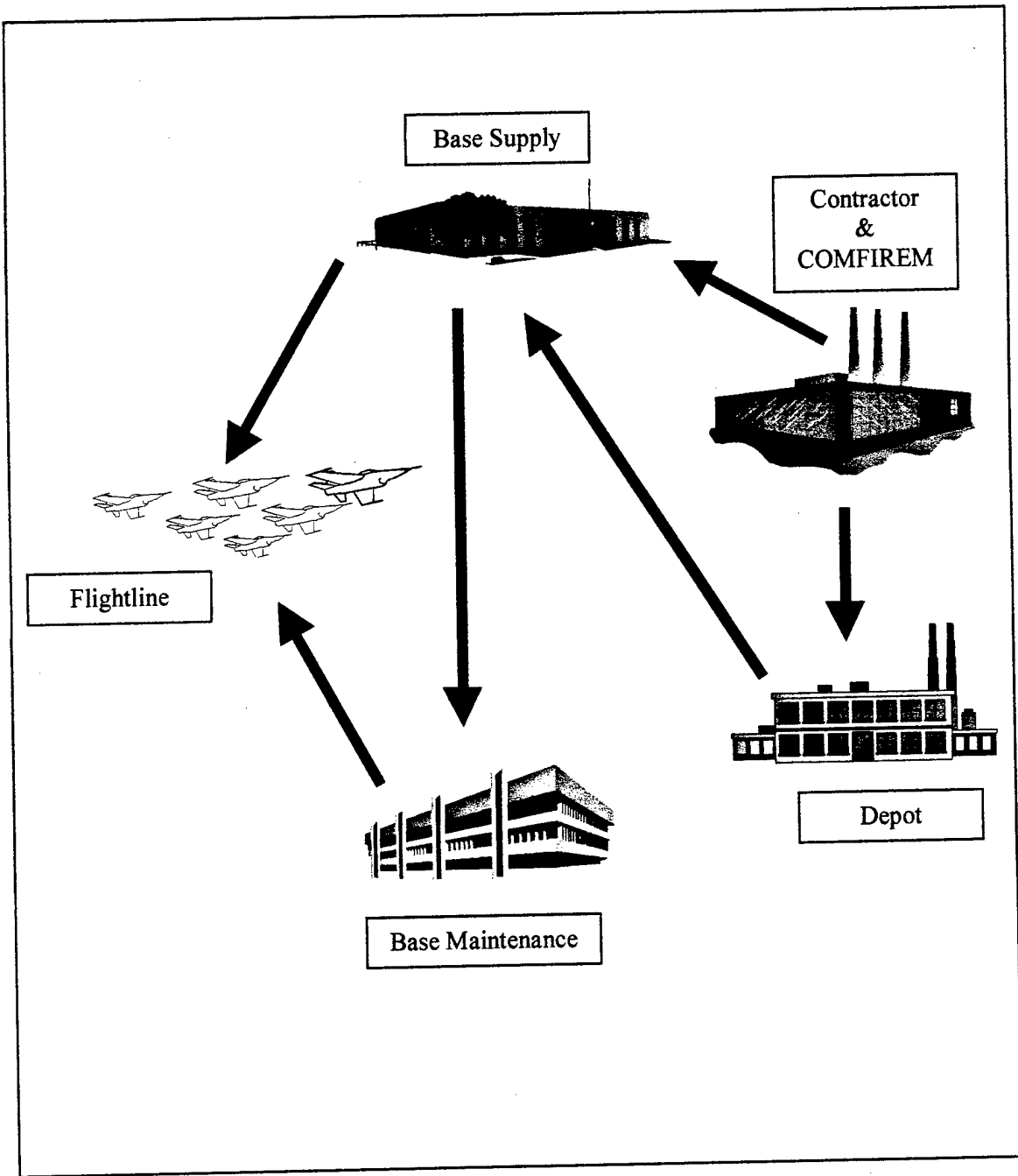

Figure 4-4 Serviceable Asset Distribution

The Processes

Flow diagrams are a very significant tool to help logistic managers identify the pipeline. These diagrams translate how the system is actually functioning. An added benefit is that flow diagrams aid in understanding the linkage between elements in a system. (2:58)

The Flightline Segment

The flightline segment is illustrated in Figure 4-5. When an engine fails on the flightline, a maintenance team evaluates the failure and decides if the engine is repairable on the flightline or not. If it is possible, the repair is performed and the engine/aircraft is returned to a service or flight condition. After that, the maintenance team proceeds with the standard paperwork procedures, which are not being described here since these procedures are beyond the scope of this study.

If the repair is not possible, or is not authorized at this maintenance level, then the engine is sent to base maintenance. With some exceptions, if it is apparent that the required service must be performed at depot level, the engine is sent directly to base supply.

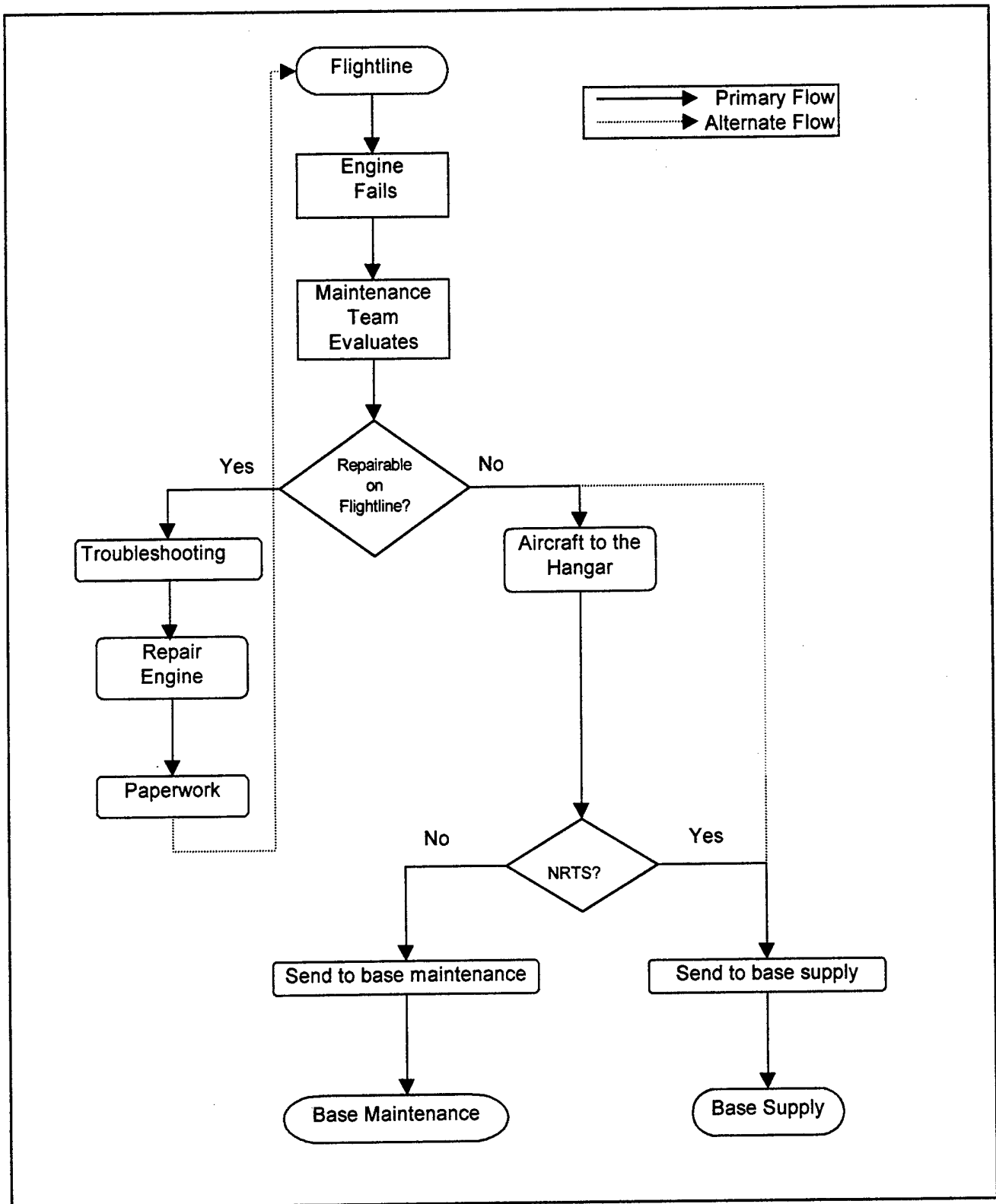

Figure 4-5 The Flightline Segment

Base Maintenance Segment

The base maintenance segment is illustrated in Figure 4-6. When an engine fails at the flightline, the maintenance personnel determine whether the item can be repaired at the flightline or not. If the repair is not possible at the flightline, the engine is taken to the engine shop, where the problem will be identified. If the service is authorized or feasible at this level, the repair begins; if not, the defective component is sent to supply. Required serviceable parts are requested from supply, and if available, are received from supply. If not available from base supply, a back order is generated. When the maintenance team receives the needed part, the engine is reassembled, adjusted and performance checked. If the engine is serviceable at this point, it may be returned to the flightline if still required, or sent to base supply for storage.

The Retrograde Segment

The retrograde segment is described in Figure 4-7. The retrograde segment begins when an engine is found non-repairable this station (NRTS) on the flightline or at base maintenance facilities, and must be sent to the depot.

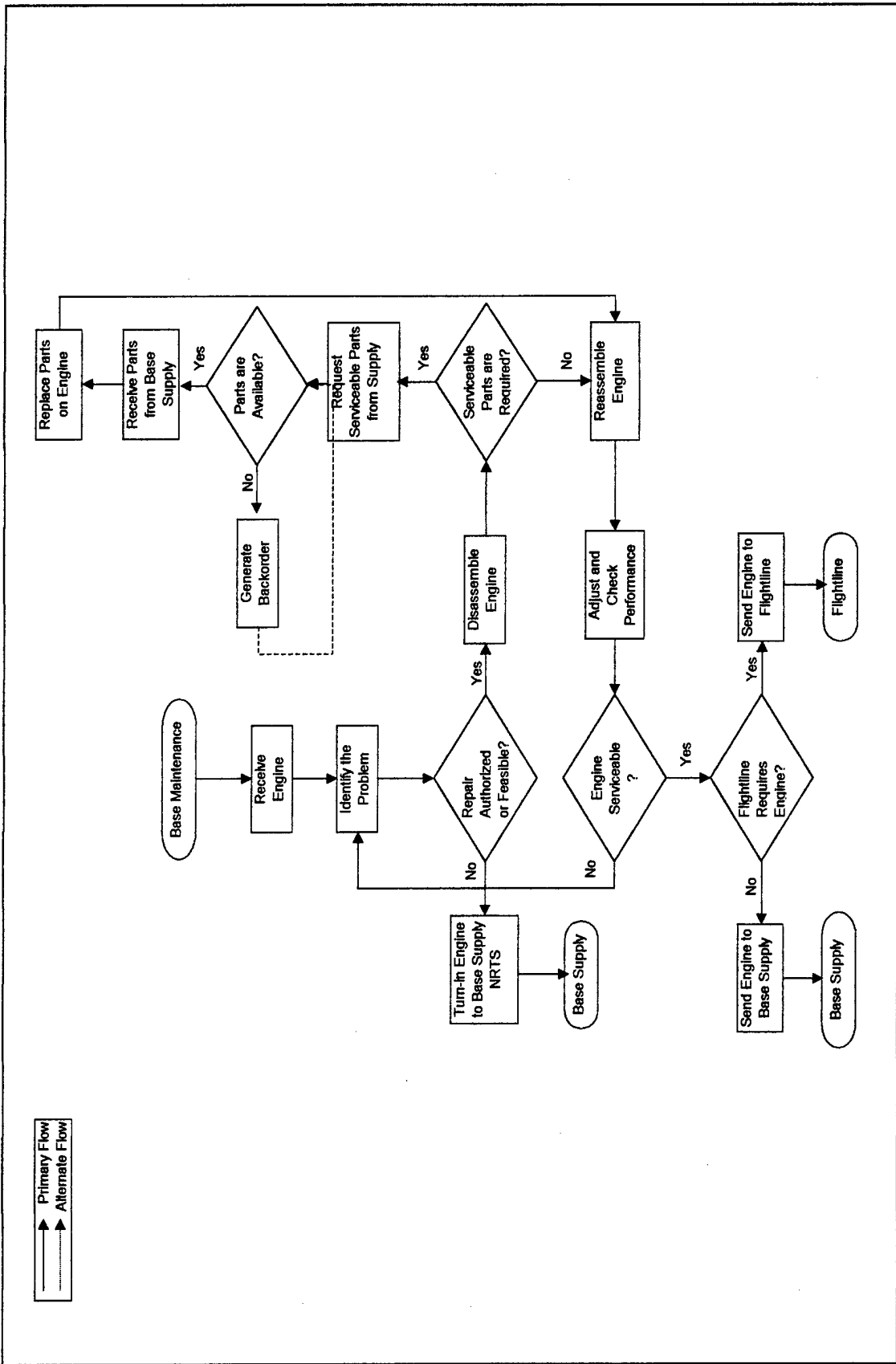

Figure 4-6 The Base Segment

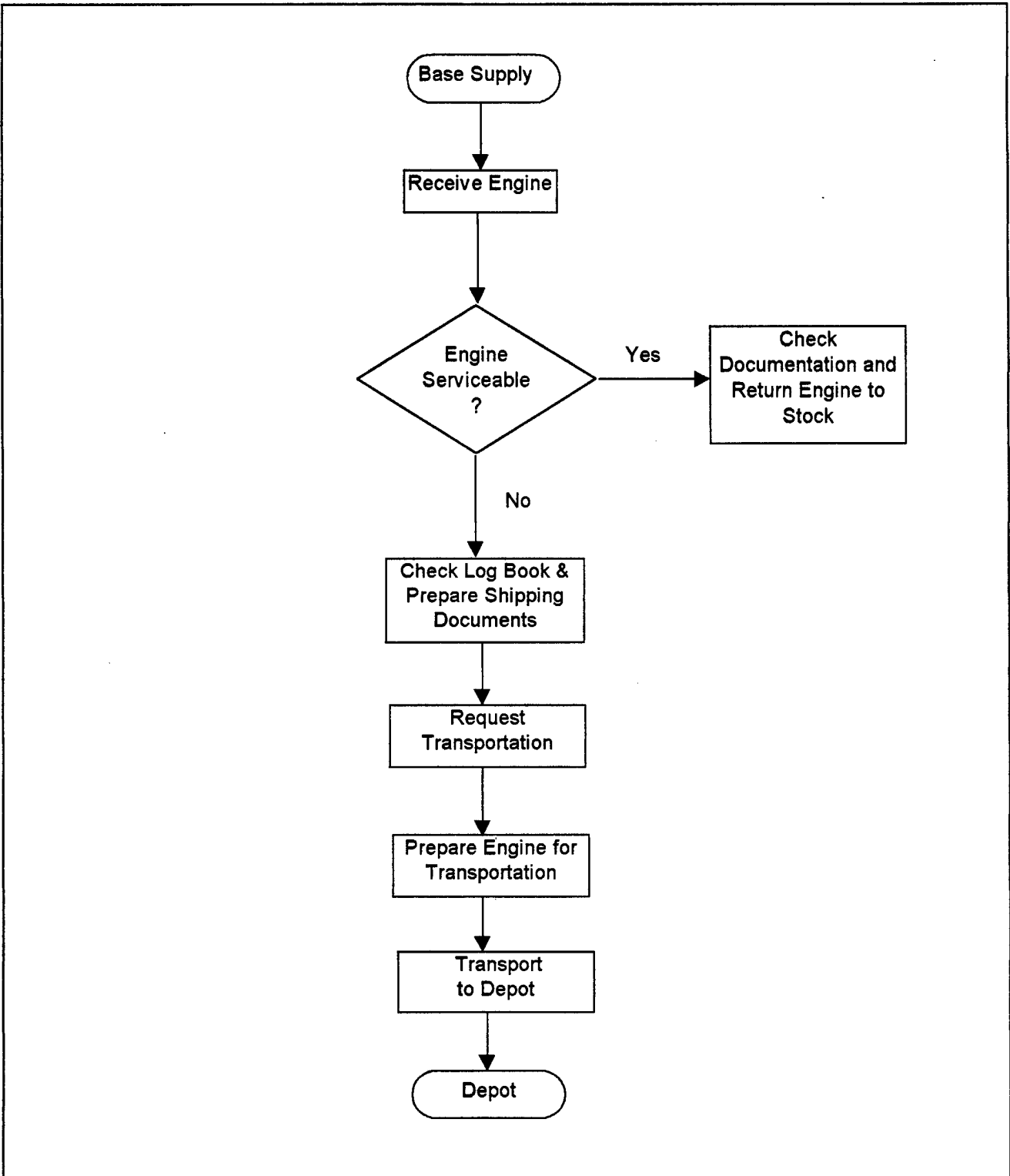

Figure 4-7 The Retrograde Segment

The engine's documents are prepared and the engine is sent to base supply, where it is received, checked (documents quantity and correctness), packed and finally, prepared for shipping. The engine is then transported to the depot by military air or surface transportation.

The Depot Segment

The depot segment is illustrated in Figures 4-8, 4-9 and 4-10. The depot segment as stated earlier, for this study, is divided into three parts:

PAMALS, at this Depot the aircraft (T-27) are received for INPP, "Inspeção Nível Parque Programada", that term refers to depot level scheduled inspection. At this time, the engine documentation is verified, a tradeoff analysis is performed. If five percent or more of the engine time between overhaul (TBO) is left, the maintenance team responsible for receiving the engine/aircraft, washes the compressor, performs a check of performance, removes the accessories and sends the engine to the depot supply.

If the TBO Limit has been reached, the maintenance crew removes the engine's accessories, sends the basic engine to supply for packing and transportation to the engine depot, PAMAAF.

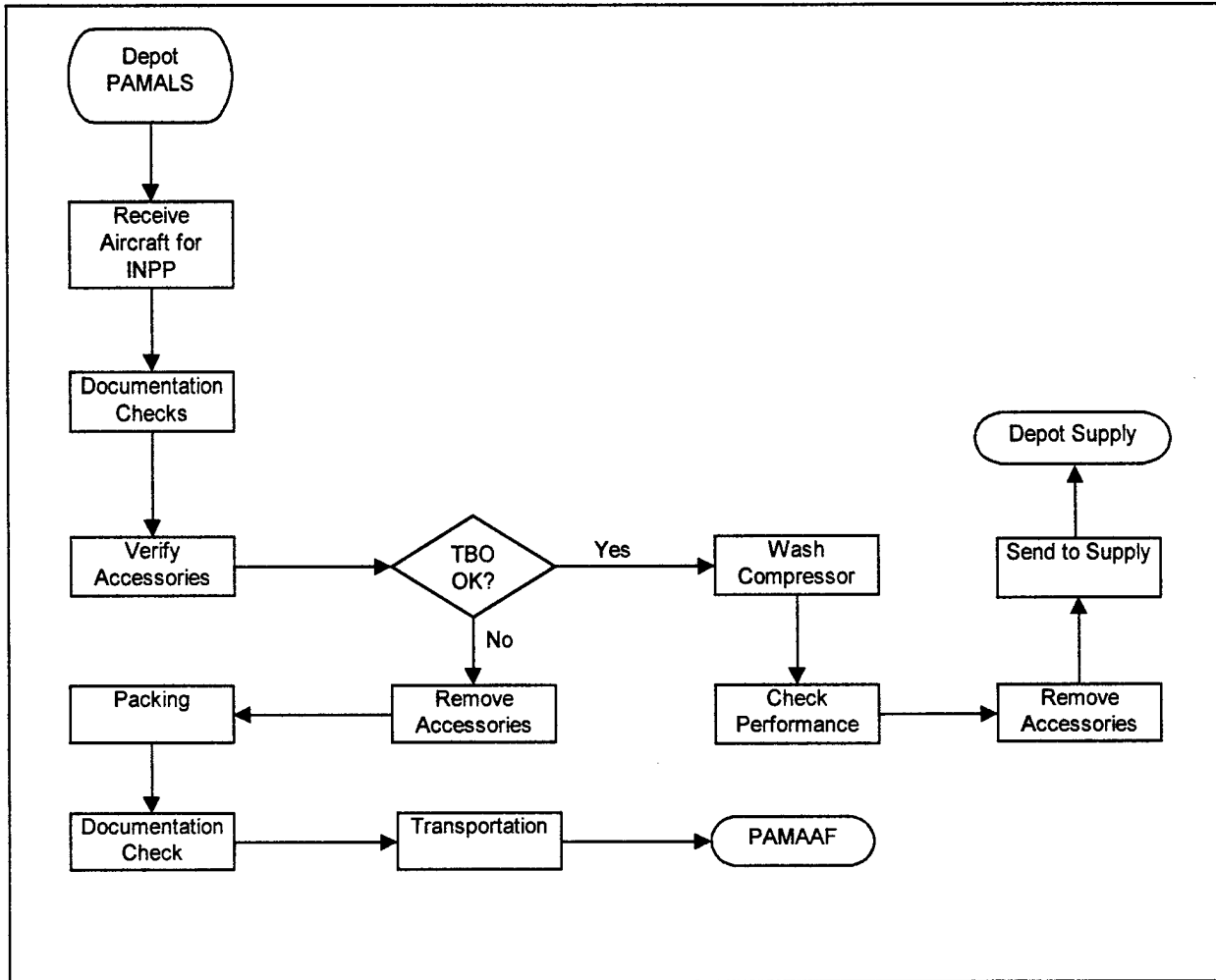

Figure 4-8 The PAMALS Segment

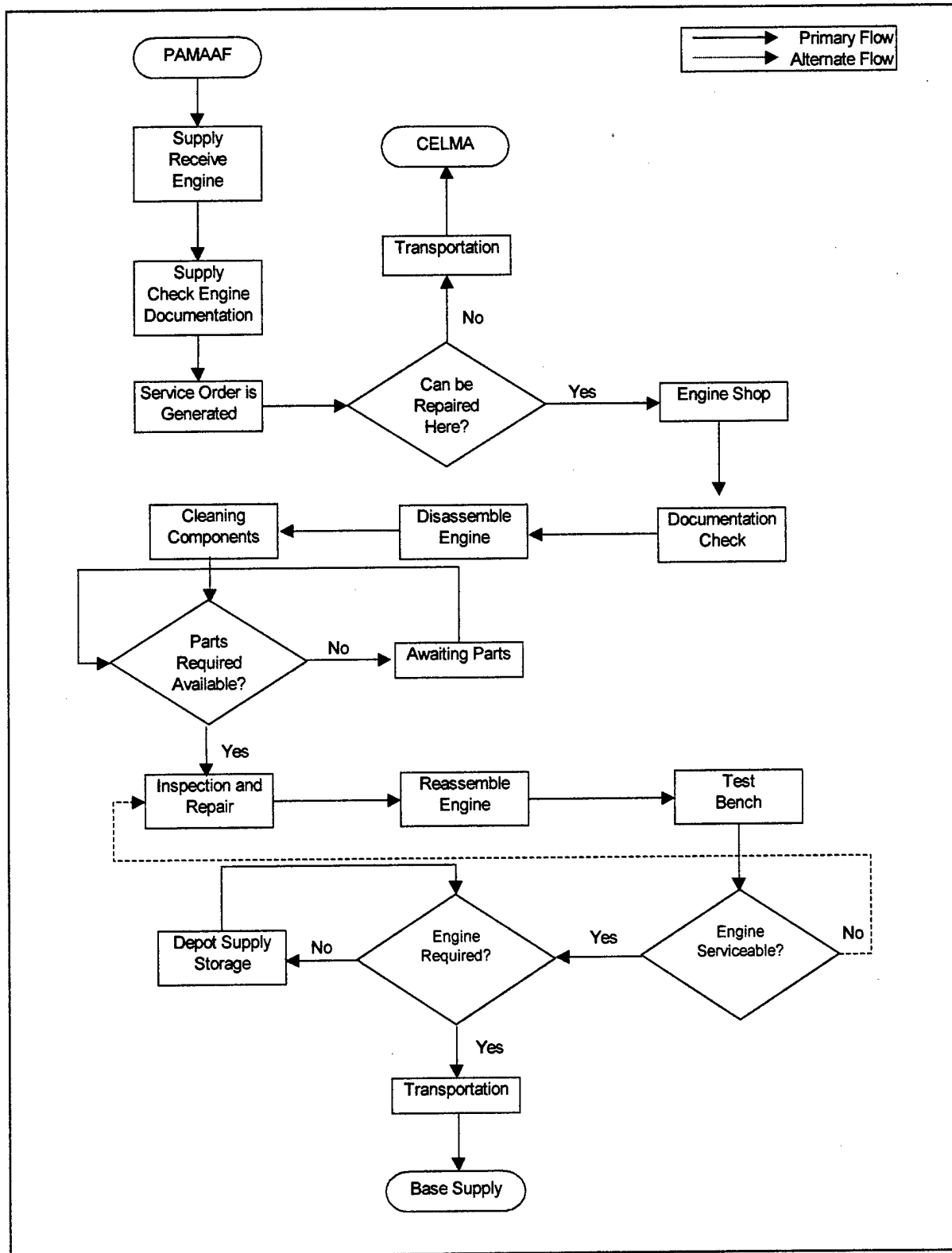

Figure 4-9 The PAMAAF Segment

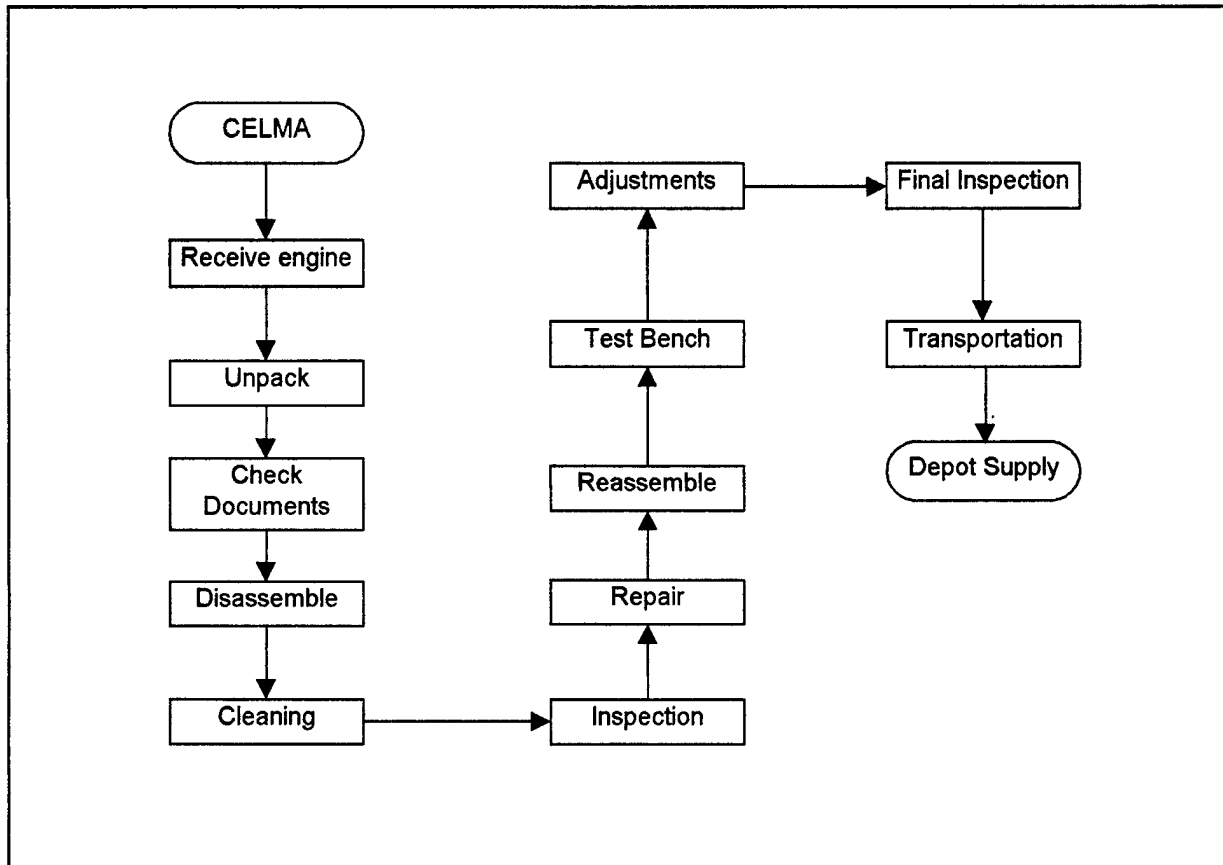

Figure 4-10 The Contractor Segment

The PAMAAF Segment, among the three is the most important, because it is the depot that has the major repair capabilities (equipment, shops, manpower and know-how). The engine is received at the PAMAAF depot supply, where the documents are checked and a service order is generated.

A service order is a standard administrative procedure in BAF. Any maintenance activity, at any level (Flightline, Base, or Depot) is kept controlled by a service order number, under which all data, such as man-hours, personnel involved and material required to perform the task, are registered.

Meanwhile, the PAMAAF will define if this particular engine will be repaired in the depot. There is no standard procedure or formal criteria to define which engine goes to the contractor and which engine stays in the depot.

This decision is made based on factors like manpower availability, complexity of the task, and the spares usually required for the service. The decision is also related to the capacity of the engine shop, the urgency required, and the expected cost to perform the services. Another criterion is funding; if the depot does not have the capacity to perform the repair, the engine sometimes is

kept on hold at the depot until the appropriate funding is granted for the repair.

At this point, one issue must be brought to the scene, the Brazilian defense industry. The depot engine shop capacity is intentionally kept below the BAF current needs to assure a minimum flow of services to the contractors. This policy, however, neither specifies the rate of distribution of the services among the contractors nor provides the necessary funding to allow PAMAAF to afford the additional costs of this procedure.

If the repair will not be accomplished in the depot, the engine is prepared and sent to the contractor's facilities. Otherwise, the item goes to the engine shop, where its logbook is studied. An engine logbook is the log or document that accompanies the equipment during its operational life. The engine logbook is used to document and keep the register of maintenance actions, major repairs, service bulletins and all information related to the engine's life.

The engine is then disassembled and its components are cleaned. If required parts for the reassembly are available, the engine is reassembled and tested at the test

bench. If the engine is labeled as serviceable, it is sent to the depot supply for storage, until it is required

CELMA, the Contractor's Flow

The engine is received at the contractor, where the engine is unpacked, inspected and a service order is opened for it. After that, the engine is disassembled, cleaned, inspected, repaired and reassembled (if no back order exists), then it is tested at the test bench, adjusted and inspected. If serviceable, the engine is returned to BAF and transported to PAMAAF.

The Distribution Segment

The depot supply receives the serviceable engine from the shop or from the contractor. If the engine is no longer required by the flightline or for any user, it is sent to storage. If the engine is required, the supply prepares the engine for shipment and transportation. When the contractor concludes an engine repair, it is received by the COMFIREM, which is located at the contractor's grounds. The COMFIREM in coordination with PAMAAF will determine the destination of the engine. There may be two cases: first, ship the engine to a base or user. Second, ship it back to PAMAAF.

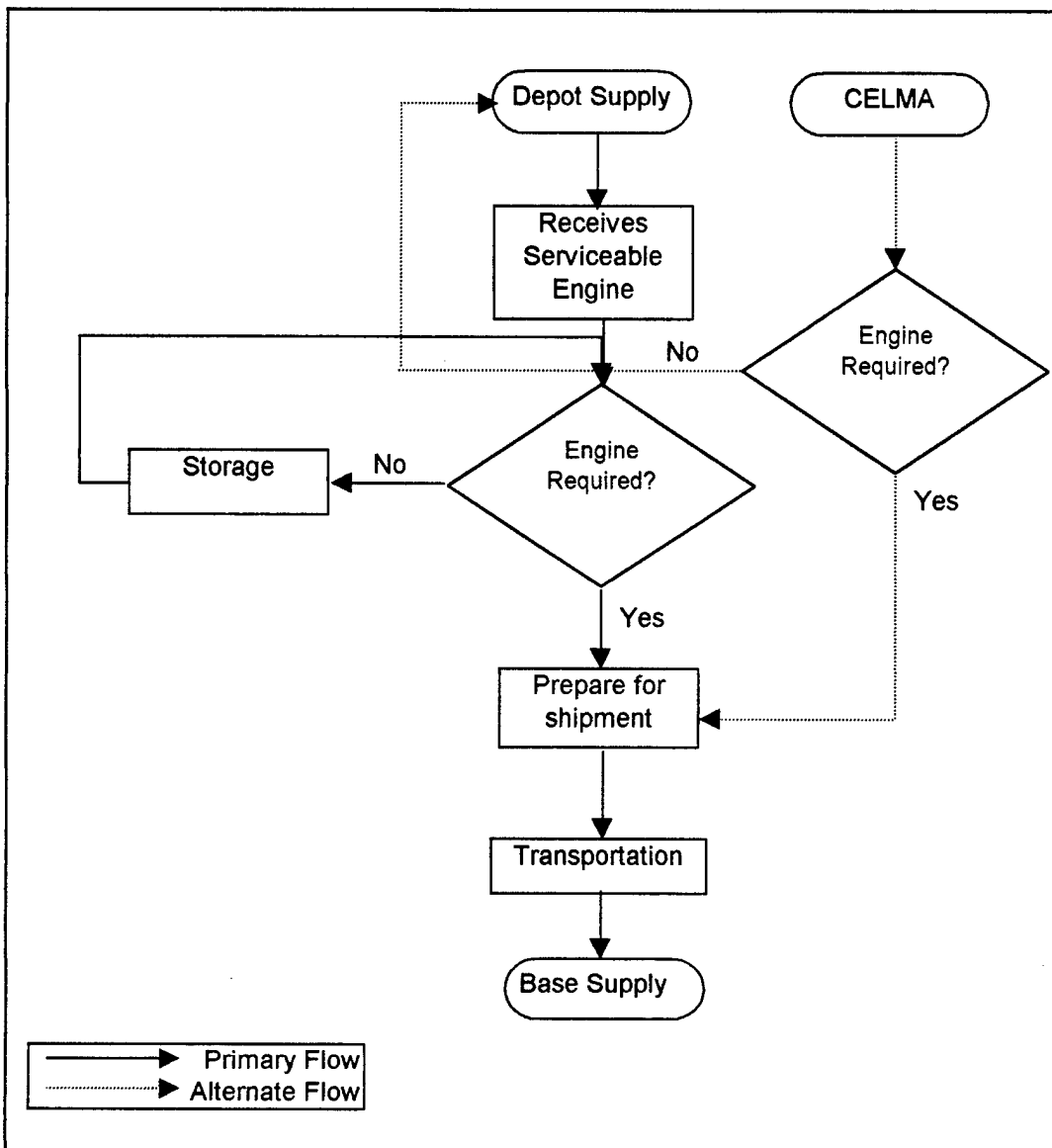

Figure 4-11 The Distribution Segment

The Impact of Transportation

During the analysis of the T-27 engine pipeline, the retrograde and distribution segments, among the others discussed above, were the ones that presented the highest variability when compared with the other segments of the pipeline. In other words, the transportation of one engine from bases to the depot and vice-versa was found to be very inconsistent. The times required to transport an engine, using the same route and the same priority, vary greatly. Due to the classified nature of this information I am not authorized to discuss the matter deeply, however, I would like to highlight this variability and consider it as one of the factors negatively impacting the performance of the overall T-27 engine logistics pipeline.

The common link among the segments is transportation. Transportation impacts greatly the retrograde and the distribution segments. As can be seen on the figure 4-12, those two segments correspond to 32% and 19%, respectively, of the repair cycle time. Together retrograde and distribution segments represent more than 50% of the repair cycle time. Suggesting, consequently, that those segments should be focused in this study, since that any improvement

on those performances would impact directly the performance of the overall repair cycle.

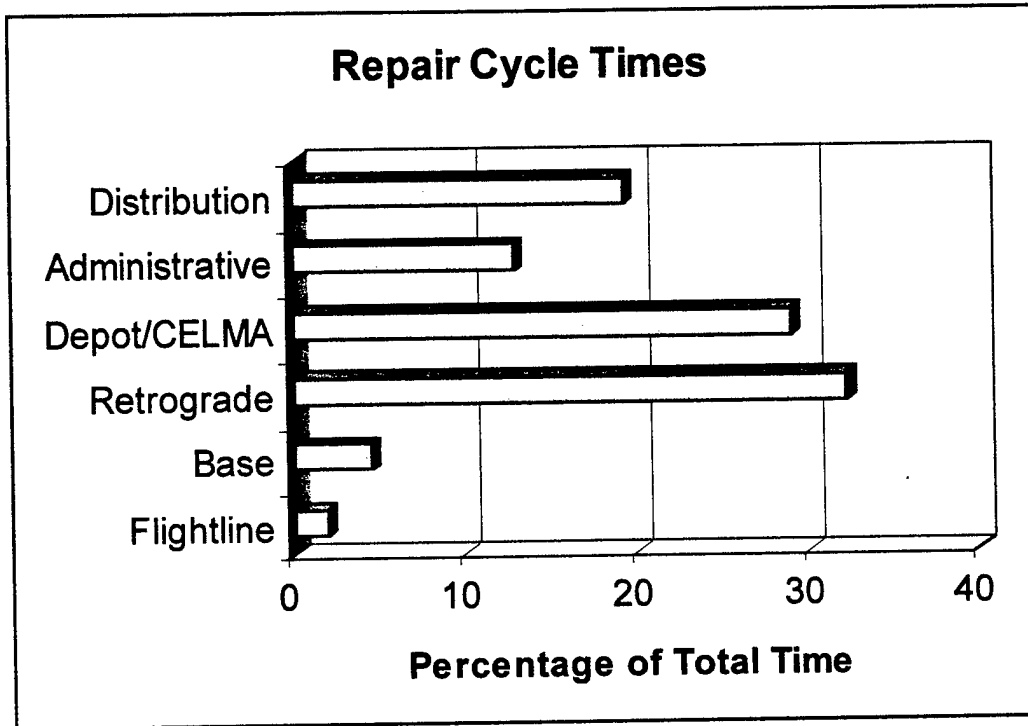

Figure 4-12 Repair Cycle Times

There are many aircraft and truck movements related to the engine pipeline being studied. Table 4-1 presents a generic approach used by BAF to transportation mode selection. It has been found that this linkage is likely to be the key to improvements on the overall system performance. The Figure 4-13 brings some of the surface transportation major routes, using the current

transportation system. The figure shows the location of some of the depots discussed earlier.

Table 4-1 Mode Selection

Criteria	Surface	Military Airlift	Commercial Air	Other
Unserviceable	X	X		
Serviceable	X	X	X	
Serviceable AOG		X	X	X

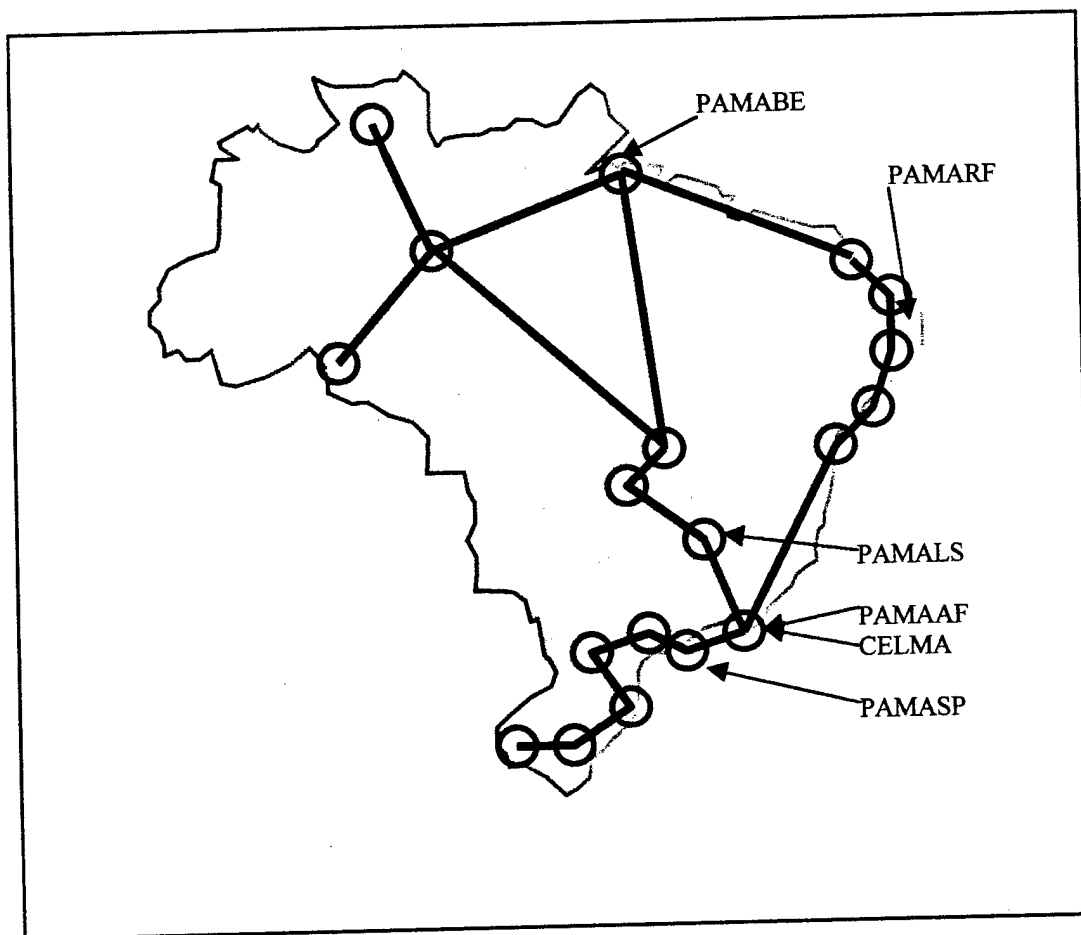

Figure 4-13 Transportation Major Routes

Bottlenecks

Analyzing the T-27 pipeline model, and the answers obtained from the questionnaire, see appendix B, it can be drawn that two major bottlenecks of the system exist as:

1. Transportation.

Transportation and the activities associated with this linkage directly influence the efficiency and effectiveness of material flow

As previously stated, the transportation times between bases and depots and vice versa, was found to be longer than expected or forecasted by the management at the depot and base levels. Also, the times required to perform the transportation of different engines over the same routes, with same priorities, vary greatly. This conclusion was drawn comparing the expected average transportation times and the real average transportation time obtained from the engines studied. In other words, this study found out that the actual average time is 28% longer than anticipated.

A statistical approach was used to analyze the times required for each segment of the engine pipeline. Variability was found in every segment, however the most significant dimension of the variability was found in the

segments mostly dependent of transportation. In a tentative to quantify the variability of each segment this study compares the Variance (σ^2) divided by Average (μ) of the times obtained from the data collected on each segment; the lower the ratio, the lower the variability of the segment. See Table 4-2.

Table 4-2 Variability

Segment	σ^2 / μ
DISTRIBUTION	1.883
ADMINISTRATIVE	1.122
DEPOT/CELMA	0.338
RETROGRADE	2.237
BASE	0.712
FLIGHTLINE	0.420

The transportation is the one bottleneck that may be better understood looking at figure 4-14, that represents the entire T-27 Engine reparable pipeline. Transportation is present in every link; the engine and its components are transported from the pipeline to the base maintenance, from base maintenance to base supply, and from base supply to the depot. This last segment encompasses many actions and

movements. Supply delivers the engine to base transportation, where the engine will be kept until the next scheduled aircraft or truck. Depending on its priority and depending on the point of origin and the destination, this engine will be managed according to the convenience of the carrier until it reaches its destination. The tools used by BAF to control these movements lack accuracy and timeliness. An efficient control of the assets moving through the pipeline facilitates the visualization of the bottlenecks.

The transportation within BAF is made basically through air and ground, military and contractors (Figure 4-13). The movements of engines within the same unit like for example, from flightline to base maintenance, or from base maintenance to base supply have not been taken under consideration because they usually take no more than an hour, at most. So, its impact on the overall pipeline is not significant for the objectives of this study.

The transportation segments considered to be important are between the bases and depots, depots and depots, depots and contractors, contractor and depots, and contractor and bases.

It has also been found that the average time required to perform the transportation itself is fairly reasonable. Many times an engine being transported is kept on hold waiting for a means of transport. Air transportation is obviously faster than ground, however, the time an engine spends waiting for air transportation sometimes is greater than the time this engine would expend being transported using ground transportation. A good example would be for instance, a serviceable engine waiting to be shipped by air (military airlift), which is scheduled, hypothetically, to take place once a week, and the surface truck fleet covers the same area twice a week. In many cases, the surface transportation time will not take more than two days, being a reliable alternative to save time.

2. Regulations.

Locally established material handling and administrative procedures at BAF organizations vary from organization to organization. The diversity in these localized procedures affects the steady flow of assets within and among the organizations.

It has been found that BAF reparable regulations are a bottleneck. The standard procedures for reparable control

and available tools to keep track of in-transit inventory or engines could be improved. From the answers obtained on the questionnaire and interviews, it can be noticed that the people involved in the process lack appropriate knowledge about the system and the process itself. During the retrograde movement of an engine, at the base supply it is understood that, as long as the engine is shipped to the next level (depot), the job is done. The depot, on the other hand, will take responsibility for the engine only when it is received. The same picture is drawn on the distribution of a serviceable engine. There is no regulations or clear definition of responsibilities during these phases. It is understood that creating more specific regulations identifying specifically the responsibilities of every unit involved in the process should be considered. These suggested solutions will be highlighted in chapter five.

Other Findings

From the answers obtained on the questionnaire, appendix B, many factors are identified by the interviewers (see table 4-3) as contributing to the lack of better

performance on the transportation segment of the T-27 engine pipeline.

Table 4-3 Most Significant Answers

Answer	Frequency
More frequent flights and trips to support the retrograde movement.	46%
Lack of visibility of the in-transit inventory.	30%
Delays in administrative procedures	23%
Delays in packing and checking the material	20%

The answers to question A reinforced the statement presented in chapter two, literature review, that no previous research provided details concerning BAF logistics pipeline and reparable management. As expected, the interviewers pointed the current regulations for reparable management and transportation, supply manuals and technical manuals.

The most frequent answers to question C, brought issues like:

1. More frequent flights and trips to support the retrograde movement;BAF maintain regular lines of support to the many bases spread around the country.

The frequency of flights to support these bases may vary, depending on the priority and the amount of cargo to be transported. Accordingly to the interviewers, BAF should review the frequency of the flights allocated to support the retrograde movement of the reparable assets. The flight schedule, as stated before, is beyond the scope of this study; for this reason, it will not be investigated any further.

2. Lack of visibility of the in-transit inventory.

The current methods to control the in-transit inventory are reliable, however it was pointed by the interviewers because of its timeliness and because it is labor intensive. Modern technology would allow better performance requiring fewer human resources.

3. Delays in packing and handling the material. The packing and handling of the reparable assets were also identified as a factor impacting negatively the T-27 engine pipeline.

4. Miscommunication within the segments. Effective communication among the segments has been pursued, however locally established procedures seem to restrict the visibility of the big picture. And consequently, the effective communication within segments.

5. Delays in administrative procedures. Due to the lack of standardization at the local administrative procedures, some units perform differently and consequently require more or less time to accomplish similar tasks, thus introducing variability into the process. Standardization and more specific regulations would minimize this aspect.
6. Problems with customs when handling international cargoes. Many times high priority items are delayed due to customs problems. This is not a simple matter; it involves Brazilian laws, and can be considered a political issue, which is beyond the scope of this study. However, the current involvement of BAF high ranking officers, who are aware of the problem, may create alternatives to reduce its impact on the engine pipeline.
7. Lack of prioritization for retrograde transportation. It was identified among the interviewers a clear and distinct approach to serviceable and unserviceable reparable items. It is understandable that a serviceable item must have high priority on the transportation, however the unserviceable item is also necessary to feed the repair cycle.

Question D requested an explanation about the criteria used by the organization to evaluate the transportation effectiveness. It has been found that the most used criterion, as expected, was time. However, a standardized or formal evaluation process was not identified.

Despite the fact that originally, the questionnaire was not meant to address sensitive information. The remaining answers of the questionnaire were understood as classified and are not being addressed here. Consequently, they are found to go beyond the scope of this thesis, and were disregarded.

The BAF T-27 Engine Pipeline Conceptual Model

The Figure 4-14 translates the conceptual T-27 Engine conceptual pipeline, however, some simplifications were made, intending to ease its development. The Depot segment that was presented in Figure 4-2 is not being specifically reproduced on the conceptual model. The PAMALS activities were considered, for the T-27 engine maintenance, and this purpose only, to be a base level, supported by PAMAAF.

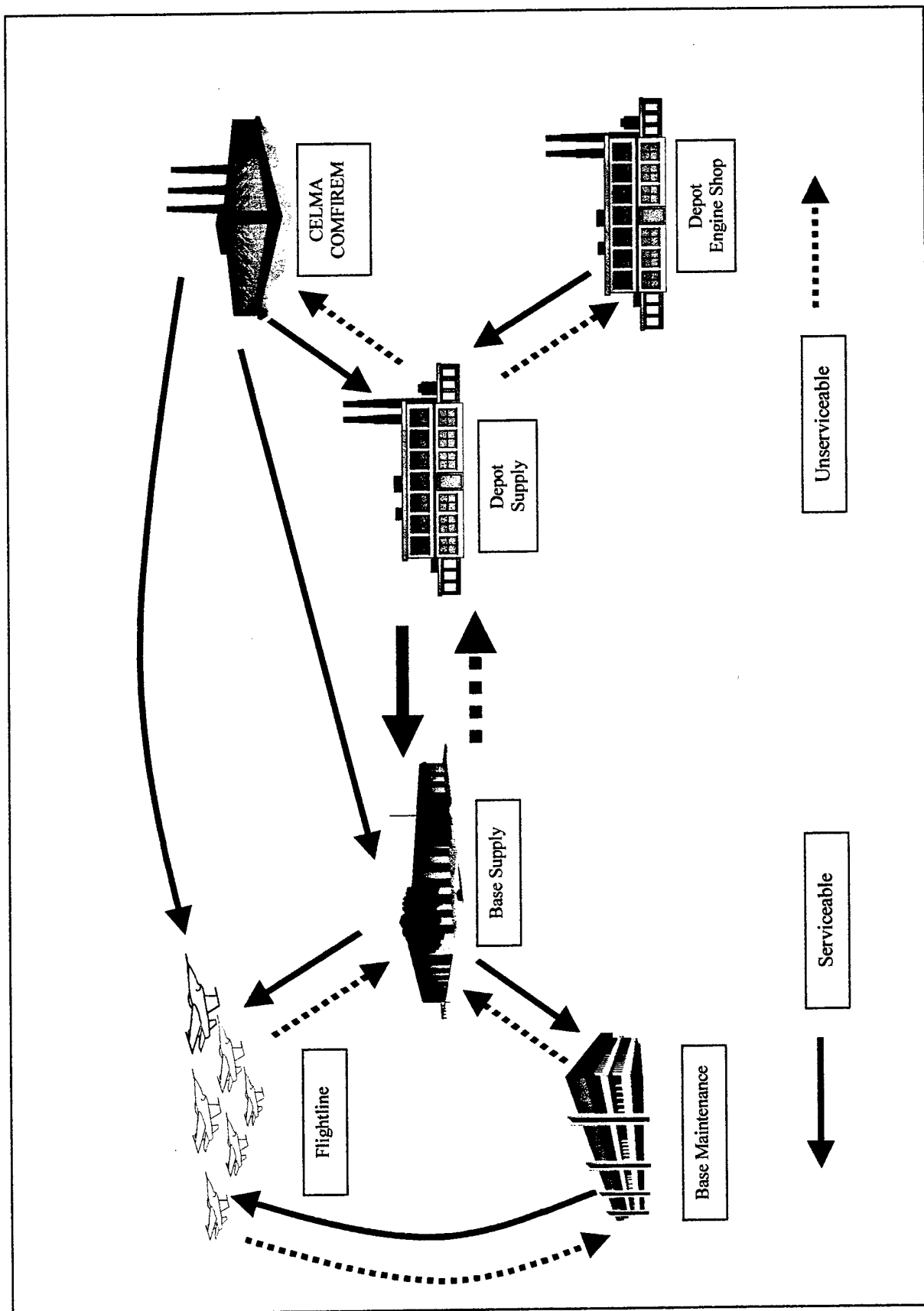

Figure 4-14 The Conceptual Pipeline

Summary of Results

In this chapter the findings of this research were presented, and each one of the five investigative questions were addressed. The subsystems which constitute the T-27 engine pipeline were presented and described, also the processes that take place in each major subsystem of the pipeline, identified which are major bottlenecks of the system and their location. Other findings are introduced, and the Conceptual BAF T-27 Engine Pipeline is given pictorially. In the next chapter the conclusions of this study will be presented, their implications to BAF, and suggestions for further researches are given.

V – Conclusions and Recommendations

Chapter Overview

The purpose of this study was to describe the process and identify the bottlenecks of the logistics pipeline of the T-27 engine and suggest managerial approaches to improve the overall system performance. In this chapter the interpretations and conclusions will be presented, as well as suggestions for further research and a summary of the research.

Interpretations and Conclusions

Since BAF early days, managerial efforts to improve the overall performance of reparable items, approached the problem trying to optimize local procedures. This study intends to present a better approach for this problem suggesting standardization.

Bond and Ruth (1989) developed a conceptual model of the USAF logistics pipeline (5:179). They divided the pipeline into four major subsystems, and identified transportation as "a linkage that directly influence the efficiency and effectiveness of materiel flows". Their study became a useful stepping stone for continued research into reparables flow through the USAF logistics pipeline.

As previously stated the broader question placed above has been refocused from the many reparables of the Tucano, to just the engine, for two reasons. First, because it narrows the scope of the research and still provides an excellent representation of the process. Second, because of the high value of an engine, minor improvements in the pipeline may represent reductions in the number of engines and consequently a significant economy of resources for the BAF. The problem associated to improvements on the T-27 reparable management practices is that no definition or model of this pipeline exists.

Analyzing all the data collected during the previous phases of this study, it can be drawn that many of the problems faced by the T-27 engine may be minimized through managerial enhancements. An example would be changes on the procedures to facilitate control over in-transit inventory. In other words, make improvements in the system that would make possible a better visibility and control of the assets through the pipeline.

In chapter IV, on table 4-3, some of the specific areas that should be improved were addressed. Apparently the following areas need to be reviewed:

1. Prioritization and transportation regulations should be reviewed to satisfy the need for more frequent flights and trips to support the retrograde movement and its lack of prioritization for transportation.
2. In-transit inventory management and visualization.
3. Standardization of local administrative procedures.

These improvements can be thought basically in three possible options:

First, proceed with changes of the processes, with low costs of implementation. This study found that there are some deficiencies on the BAF reparable regulations. As stated before, the lack of knowledge and uncertainty at base and depot levels, regarding reparable management, suggests deficiencies on current regulations. It would be necessary to specify more explicit and detailed procedures for each unit involved on the pipeline, to override local optimal procedures, in one attempt to standardize the flow of assets and improve the overall process performance

The transportation scheduling and management should be reviewed and optimized. Also the prioritization to the transportation of assets should be determined by the recipient organization. This means, in the retrograde segment the priority be determined by the affected Depot,

the organization that can identify which components are critically needed by the shop repair cycle and which are not. In the distribution segment, it should be determined by the Base or organization that is requesting the asset. They can identify the items that are most urgent to fulfil their requirements. Also, standardization of the local administrative procedures would eliminate some local "unique" procedures that negatively impact the repair cycle time.

Second, technological changes to improve the visibility of the pipeline, particularly in transportation, through the use of Bar Code Readers, Radio Frequency Tags, and Electronic Data Interchange, easing the control of the assets.

This approach is thought the most expensive since it would require the acquisition of new system or systems. Bar Codes, Radio Frequency Tags and Electronic Data Interchange, as discussed in Chapter II, are modern technologies and have been increasingly used by civilian manufacturers, suppliers, and in the military segment.

Third, implement a combination of the managerial and technological changes. This mix is thought to be a mid-way between a pure administrative or managerial change in the

processes and an acquisition of a system to improve the pipeline visibility and facilitate tracking the assets through the pipeline. Cost is a major concern in this analysis; BAF has been struggling to deal with constrained resources and reductions on the budget. The bar code would be the least expensive system to be acquired, since it would require the acquisition of specific software, already in the market, available of the shelf. Besides, the bar code would generate benefits easing the visualization of the in transit inventory and consequently making possible, as Gonselman (1991) concluded, the visibility over the flow of assets, which is also critical to management. A good visualization of the pipeline allows the decision-maker a better understanding of the process, and also better opportunities to interfere within the process, performing the necessary adjustments responding to eventual unforeseen problems.

If BAF management decided to adopt this solution, it would be necessary the involvement of BAF Directorate of Material, to determine a reassessment of current regulations and establishment of the guidelines. As well as the necessary funding to acquire and field bar code equipment and software.

Suggestions for Further Research

The BAF current knowledge about its logistics processes would be greatly enhanced if new studies were done investigating issues like:

1. The Brazilian Air Force Conceptual Pipeline, relationships among its major subsystems.
2. Modeling and simulating the T-27 Engine Pipeline.
3. Study of other aircraft types and identification of their particular segments.
4. Consumables management on the BAF. Review the current forecasting methods.
5. Repair prioritization. Study the scheduling and prioritization of Depot repair methods.
6. Transport prioritization and impacts of transportation times over the T-27 engine pipeline.

Summary of Research

This research addresses the management of Brazilian Air Force (BAF) reparable assets. Chapter One describes the background information, specific problem, research questions, investigative questions, limitations, research objectives, and expected results of the study.

In Chapter Two, the meaning of the term reparable is discussed briefly. Also a quick review of the United States Air Force (USAF) background, the maintenance levels and transportation modes of the Brazilian Air Force (BAF).

Chapter Three describes the procedures followed in this study. It has been found that an exploratory study is most appropriate. It has also been found that a qualitative approach is required.

In Chapter Four the findings of this research were presented, and each one of the five investigative questions were addressed. The subsystems which constitute the T-27 engine pipeline were presented and described, also the processes that take place in each major subsystem of the pipeline, identified which are major bottlenecks of the system and their location. Other findings are introduced, and the Conceptual BAF T-27 Engine Pipeline is given pictorially.

In Chapter Five the suggested solutions are presented. The study suggests three possible solutions. First, proceed managerial changes, changes on the processes, with low costs of implementation. Second, technological changes to improve the visibility of the pipeline, particularly in the transportation segment, through the use of Bar Code

Readers, Radio Frequency Tags, and Electronic Data Interchange, easing the control of the assets. Third, it could be a reassessment and improvement of current regulations associated with an acquisition of identification and tracking devices. Use a combination of the managerial and technological approaches.

Appendix A. List of Acronyms and Abbreviations

AATF	Airworthiness Assurance Task Force
ABC	Activity-Based Costing
acft	aircraft
AD	Airworthiness Directive
AFB	Air Force Base
AFIT	Air Force Institute of Technology
AIA	Aerospace Industries Association of America
AOG	Aircraft On Ground
ASC	Aeronautical Systems Center
ATA	Air Transport Association
BA	British Aerospace
BAF	Brazilian Air Force
CAIV	Cost as Independent Variable
CBS	Cost Breakdown Structure
CD-ROM	Compact Disc - Read-Only Memory
CELMA	Companhia Eletro-Mecânica Aeronáutica
CER	Cost Estimating Relationship
Cont.	Continued
CORE	Cost-Oriented Resource Estimating
Develop.	Development
DoD	Department of Defense
DTC	Design-to-Cost
EOH	Engine Overhaul
FAA	Federal Aviation Administration
GAFB	Galeão Air Force Base
GAMD	Galeão Aeronautical Materiel Depot
GSE	Ground Support Equipment
hr	hour
ILA	Instituto de Logística da Aeronáutica
kg	kilogram
l	liter

LCC	Life Cycle Cost, Life Cycle Costing
M	manpower
m	meter
Maint.	Maintenance
Mainten.	Maintenance
O&S	Operation and Support
OPAC	Online Public Access Catalog
PAMAAF	Parque de Material Aeronáutico dos Afonsos
PAMABE	Parque de Material Aeronáutico de Belém
PAMAGL	Parque de Material Aeronáutico do Galeão
PAMALS	Parque de Material Aeronáutico de Lagoa Santa
PAMARF	Parque de Material Aeronáutico de Recife
PCS	Permanent Change of Station
PDS	Personnel Distribution Chart
POL	Petroleum, Oil, and Lubricants
R&D	Research and Development
SB	Service Bulletin
SMP	Structural Mandatory Program
SMS	Supply and Maintenance Squadron
SSID	Supplemental Structural Inspection Document
SWG	Structures Working Group
TQM	Total Quality Management
VARIG	Viação Aérea Rio-Grandense
yr	year

Appendix B. Questionnaire

- A. Is there any official publication in the BAF that regulates the reparable transportation? If any, please identify them.
- B. Which organizations of BAF have importance in the reparable transportation process?
- C. Please list all the possible problems that delay the reparable movement throughout the pipeline. For each listed problem, assign a frequency index:
- 1 - very rare 2 - rare 3 - sometimes
4 - most of the times 5- all the times
- D. Please explain the current criteria used by your organization to evaluate the transportation effectiveness
- E. What is the T-27 engine failure rate at your unit?
- F. What is the capacity of the engine shop at your organization?
- G. What would you do to improve the performance of the T-27 repair process?
- H. How is transportation between your organization and the Depot is performed?
- I. How long does this transportation take?
- J. How does your transportation sector coordinate the movement of assets?
- K. How does your organization control the movement of assets?
- L. Are there any contractors? If so, what are their repair capabilities?
- M. How frequently are the assets moved to and from your organization?
- N. How does your unit keep track of the in-transit reposables?

Appendix C. List of Sample Engines

Serial Number	Date of Removal
26003	16-Nov-94
26005	09-Jan-95
26007	15-Jul-92
26013	14-Nov-95
26017	29-Jun-90
26018	12-Feb-93
26025	30-May-96
26030	23-Jul-96
26031	19-Apr-94
26048	23-Sep-93
26054	30-Apr-97
26063	22-Apr-96
26064	28-Nov-90
26076	30-Nov-93
26082	14-Nov-93
26086	16-Oct-91
26088	16-Nov-94
26094	29-Jul-92
26095	28-Sep-95
26096	24-Nov-94
26096	24-Nov-94
26097	13-Jul-88
26097	10-Jun-94
26102	01-Jul-92
26102	09-Apr-96
26103	18-Nov-91
26105	13-Jan-88
26110	21-Dec-92
26113	19-Dec-93
26118	02-Feb-93
26120	17-May-95
26122	03-Aug-95
26123	27-Mar-95
26130	09-Oct-96
26132	15-Jun-97
26144	06-Feb-96
26147	31-May-95
26267	26-Sep-95
26271	04-Mar-96
26278	21-Feb-94
26278	18-Sep-96
26279	06-Apr-94

Appendix D. U.S. Army Memorandum

DEPARTMENT OF THE ARMY
HEADQUARTERS, EIGHTH UNITED STATES ARMY
UNIT #15236
APO AP 96205-0009

REPLY TO

ATTENTION OF: EAGD-MS-LP

17 July 1997

MEMORANDUM FOR SEE DISTRIBUTION

**SUBJECT: Policy for Retrograde and Accountability of
Radio Frequency (RF) Tags**

1. This memorandum establishes procedures and responsibilities for Supply Support Activities (SSA) that receive shipments with RF tags. Commanders and accountable officers will account for and emphasize expeditious return procedures of RF tags.
2. Currently, Class IX repair parts shipped to Korea via Federal Express from Defense Distribution Region West (DDRW) have RF tags affixed to the pallets. As the RF tag/In-transit Visibility (ITV) technology matures, other types of cargo coming into theater will also use RF tags.
3. RF tags are expendable, recoverable and reusable property and do not require property book accounting. However, each tag costs the Government approximately \$200, and the logistics system is utilizing a fixed quantity of these tags. Receiving SSAs must initiate a responsible collection and retrograde program to ensure the proper distribution of RF tags back into the logistics system for reuse.
4. There are two categories of RF tags. Each requires a different collection and retrograde procedure.
 - a. RF tags affixed to commercial shipping containers, 463L air pallets, commercial vans, or on a box, crate, or other container are considered as separate items and will be removed, deactivated, collected, and retrograded.
 - b. RF tags affixed to military vehicles, milvans, and internal slingable units (ISU) are part of that equipment and will not be removed.
5. SSAs will take the following actions when the RF tags reach their point of destination:

a. Remove the RF tag from the container (unless paragraph 4b applies). Open the back cover and invert the lithium battery. This deactivates the tag and will extend the life of the battery. Close the cover.

b. Collect the RF tags in a shipping crate or package. Retrograde the RF tags on a monthly basis to the theater collection point at Materiel Support Center-Korea. A completed DA Form 200, Transmittal Record, must accompany each shipment in order for MSC-K to maintain a supply and transportation audit trail.

c. Ship the RF tags to Commander, MSC-K, Unit #15384, ATTN: EANC-MSY, APO AP 96260-0286. Place the statement,

"This package contains non-regulated lithium batteries.",

on the outside of all RF tag packages.

d. Do not retrograde the RF tags in their active mode. Ensure all RF tags are nonoperational by inverting their lithium batteries.

6. MSC-K will receive RF tags from all EUSA activities and periodically return them to Sharpe Depot (DDRW).

a. Mailing address:

Transportation Office, Sharpe Site
DDJC-THSF, Bldg 330
ATTN: Marlene Jetton
P.O. Box 960001
Stockton, CA 95296-0112

b. Freight Address:

Defense Distribution Region West
DDJC-THSF-Bldg 330, ATTN-Marlene Jetton
Lathrop, CA 95330-0103

c. Department of Defense Activity Code: SW3224

7. Point of contact for this supply policy is CPT Deidre R. Chung, EAGD-MS-LP

(DSN 723- 4438; fax DSN 723-7195; and e-mail chungd@usfk.korea.army.mil).
POC for RF tag/ITV is CPT Brian M. Clark, EAGD-T-ITV (DSN 725-8437; fax DSN 724-7184; and e-mail fkj4-t-pe@emh6.korea.army.mil).

BARRY D. BATES
BG, USA
Assistant Chief of Staff, G4

DISTRIBUTION:

CDR, 2nd INF DIV, ATTN: EAID-GL, APO AP 96224-0368
CDR, 19th TAACOM, ATTN: EANC-GM, APO AP 96218-0171
CDR, 175th FINCOM, ATTN: EAFCLP, APO AP 906205-0073
CDR, 8th PERSCOM, ATTN: EAPC-S4, APO AP 96205-0089
CDR, 17th AVN BDE, ATTN: EAAV-SM, APO AP 96205-0043
CDR, 501st MI BDE, ATTN: IABDK-L, APO AP 96205-0055
CDR, 18th MEDCOM, ATTN: EAMC-H-L, APO AP 96205-0054
CDR, 8th MP BDE, ATTN: EAPB-L, APO AP 96205-0050
CDR, 1st SIG BDE, ATTN: ASQK-LS (DLOG), APO AP 96205-0044
CDR, 6th CAV BDE, ATTN: EABH-S4, Unit # 15711, APO AP 96271-0711

Bibliography

1. Blanchard, Benjamin S. Logistics Engineering and Management, Fourth Edition, Prentice-Hall Inc., 1991.
2. Blanchard, Benjamin S. System Engineering Management, First Edition, John Wiley & Sons, 1990.
3. Blanchard, Benjamin S. and Wolter J. Fabrycky, System Engineering And Analysis, Second Edition, Prentice-Hall international series in industrial and systems engineering, 1990.
4. Blanchard, Benjamin S. and Wolter J. Fabrycky, Life-Cycle Cost and Economic Analysis, First Edition, Prentice-Hall international series in industrial and systems engineering, 1991.
5. Bond, Craig A. and Marvin E. Ruth, A Conceptual Model of the Air Force Logistics Pipeline, MS Thesis, AFIT/GLM/LSM/89S2. School of Systems and Logistics, Air Force Institute of Technology (AU), Wright-Patterson AFB OH, September 1989 (AD-A216158).
6. Cooper, Donald R. and William C. Emory, Business Research Methods, Fifth Edition, Richard D. Irwin Inc., 1995.
7. Foxtton, P. D. Powering War: Modern Land Force Logistics, First Edition, Brassey's, London, United Kingdom, 1994.
8. Glaskowsky, Nicholas A., Donald R. Hudson, and Robert M. Ivie, Business Logistics, Third Edition, Harcourt Brace Jovanovich Inc., 1992
9. Gordon, Judith R. and Steven R. Gordon, Information Systems: A Management Approach, First Edition, Harcourt Brace & Company, 1996

10. Gray, Edmund R. and Larry R. Smeltzer, Management: The Competitive Edge, First Edition, Macmillan Publishing Company, New York NY, 1989
11. Gunselman, John H., "Documentary on Desert Shield/Storm Supply Support", Air Force Journal of Logistics, page 11-16 (Fall 1991).
12. Kettner, Bradley M., William M. Wheatley, and David K. Peterson, "Redefining Before Refining: The USAF Reparable Item Pipeline", Air Force Journal of Logistics, 16: 5-11 (Fall 1992).
13. Lambert, Douglas M. and James R. Stock, Strategic Logistics Management, Third Edition, Richard D. Irwin Inc., 1992.
14. Langford, John W. Logistics Principles and Applications, First Edition, McGraw-Hill, Inc., 1995
15. Lieb, Robert C. Transportation, Fourth Edition, Dame Publications. Inc., 1994
16. Ministério Da Aeronáutica. Manutenção Nivel Organico e Base. NSMA 65-2, Rio de Janeiro - Brazil: DIRMA, 15 March 1994.
17. Ministério Da Aeronáutica. Manutenção Nivel Parque. NSMA 65-3, Rio de Janeiro - Brazil: DIRMA, 15 March 1994.
18. Ministério Da Aeronáutica. Códigos de Categoria do Material Aeronáutico. IMA 65-16, Rio de Janeiro - Brazil: DIRMA, 29 August 1994.
19. Ministério Da Aeronáutica. Controle de Motores de Aeronaves. IMA 65-22, Rio de Janeiro - Brazil: DIRMA, 04 October 1989.
20. Ministério Da Aeronáutica. Programa de Manutenção de Reparáveis. IMA 65-17, Rio de Janeiro - Brazil: DIRMA, 15 March 1994.

21. Ministério Da Aeronáutica. Coleta de Dados De Manutenção e Defeito Nível Orgânico e Base. IMA 66-3, Rio de Janeiro - Brazil: DIRMA, 22 August 1994.
22. Ministério Da Aeronáutica. Planejamento de Material em Manutenções Programadas. IMA 66-19, Rio de Janeiro - Brazil: DIRMA, 15 December 1995.
23. Ministério Da Aeronáutica. Requisição, Análise e Aquisição de Material Aeronáutico. IMA 67-5, Rio de Janeiro - Brazil: DIRMA, 11 March 1991.
24. Ministério Da Aeronáutica. Guia de Movimentação de Material. IMA 67-21, Rio de Janeiro - Brazil: DIRMA, 23 February 1994.
25. Silver, Bradley and others. "Reduction of the Recoverable Pipeline", Air Force Journal of Logistics, 15: 18-20 (Summer 1991).
26. Silver, Edward A. Decision Systems For Inventory Management and Production Planning, Second Edition, John Wiley & Sons, 1985.

Vita

Major Jorge Barros Santos was born on 31 July 1958 in Belo Horizonte, MG, Brazil. He graduated from Escola Preparatória de Cadetes do Ar (EPCAR) High School in 1977 and entered undergraduate studies at the Air Force Academy (AFA) in Pirassununga, SP, in 1978. He received his commission on 10 December 1981, and graduated with a Bachelor of Science degree in Science of Aviation on the same date. He was then assigned to the "Centro de Aplicações Táticas e Recompimento de Equipagens (CATRE)" in Natal, RN, where he completed his flight training. In 1983 he was assigned to the Fifth Air Transportation Squadron, in Canoas, RS, where he worked as a Crew-Member of a C-95 Bandeirante. Since then, he has been assigned to many Brazilian Air Force Flight Units, having flown approximately 5,000 hours on C-95 Bandeirante, VC-97 Brasília, U-7 Sêneca, T-27 Tucano, and VU-35 Lear Jet. In March 1996 he entered the Graduate School of Logistics and Acquisition Management, Air Force Institute of Technology, and will move on to the Brazilian Air Force Institute of Logistics (ILA) at São Paulo AFB, SP, Brazil, upon graduation in June 1998.

Forwarding Address: Av. Monteiro Lobato, 4455 - Cumbica
CEP 07184-000 Guarulhos - SP
Brazil

REPORT DOCUMENTATION PAGE

Form Approved
OMB No. 074-0188

Public reporting burden for this collection of information is estimated to average 1 hour per response, including the time for reviewing instructions, searching existing data sources, gathering and maintaining the data needed, and completing and reviewing the collection of information. Send comments regarding this burden estimate or any other aspect of the collection of information, including suggestions for reducing this burden to Washington Headquarters Services, Directorate for Information Operations and Reports, 1215 Jefferson Davis Highway, Suite 1204, Arlington, VA 22202-4302, and to the Office of Management and Budget, Paperwork Reduction Project (0704-0188), Washington, DC 20503

1. AGENCY USE ONLY (Leave blank)		2. REPORT DATE June 1998	3. REPORT TYPE AND DATES COVERED Master's Thesis	
4. TITLE AND SUBTITLE THE T-27 "TUCANO" ENGINE PIPELINE OF THE BRAZILIAN AIR FORCE: A MANAGERIAL APPROACH			5. FUNDING NUMBERS	
6. AUTHOR(S) Jorge Barros Santos, Major, Brazilian Air Force				
7. PERFORMING ORGANIZATION NAMES(S) AND ADDRESS(S) Air Force Institute of Technology 2750 P Street WPAFB, OH 45433-7765			8. PERFORMING ORGANIZATION REPORT NUMBER AFIT/GLM/LAL/98J-2	
9. SPONSORING / MONITORING AGENCY NAME(S) AND ADDRESS(ES) N / A			10. SPONSORING / MONITORING AGENCY REPORT NUMBER	
11. SUPPLEMENTARY NOTES				
12a. DISTRIBUTION / AVAILABILITY STATEMENT Approved for public release; distribution unlimited.			12b. DISTRIBUTION CODE	
13. ABSTRACT (Maximum 200 Words) The T-27 is a Brazilian-made aircraft, manufactured by "Empresa Brasileira de Aeronáutica - EMBRAER". The purpose of this study is to describe the processes that take place in the logistic pipeline of the T-27 Engine. With the objective of identifying any existent bottlenecks and suggests managerial approaches to improve the overall system performance.				
14. SUBJECT TERMS Aircraft Maintenance, Logistics Pipeline, Reparables, Repairable Management, Repair Cycle, Logistics Management, Maintenance Management			15. NUMBER OF PAGES 95	
			16. PRICE CODE	
17. SECURITY CLASSIFICATION OF REPORT UNCLASSIFIED	18. SECURITY CLASSIFICATION OF THIS PAGE UNCLASSIFIED	19. SECURITY CLASSIFICATION OF ABSTRACT UNCLASSIFIED	20. LIMITATION OF ABSTRACT UL	

