



**THE POTENTIAL INFLUENCE OF  
ADVANCED LOGISTICS  
ON DEFENSE AIR TRANSPORTATION**

Graduate Research Paper

Paul J. Judge, Major, USAF

AFIT/GMO/LAL/98J-10

19981009 049

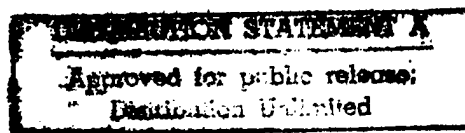

**DTIC QUALITY INSPECTED &**

**DEPARTMENT OF THE AIR FORCE  
AIR UNIVERSITY  
AIR FORCE INSTITUTE OF TECHNOLOGY**

**Wright-Patterson Air Force Base, Ohio**

AFIT/GMO/LAL/98J-10

**THE POTENTIAL INFLUENCE OF  
ADVANCED LOGISTICS  
ON DEFENSE AIR TRANSPORTATION**

Graduate Research Paper

Paul J. Judge, Major, USAF

AFIT/GMO/LAL/98J-10

Approved for public release; distribution unlimited

The views expressed in this graduate research paper are those of the author and do not reflect the official policy or position of the Department of Defense or the U.S. Government.

AFIT/GMO/LAL/98J-10

**THE POTENTIAL INFLUENCE OF  
ADVANCED LOGISTICS  
ON DEFENSE AIR TRANSPORTATION**

GRADUATE RESEARCH PAPER

Presented to the Faculty of the Graduate School of

Logistics and Acquisition Management of the

Air Force Institute of Technology

Air University

Air Education and Training Command

In Partial Fulfillment of the

Requirements for the Degree of

Master of Air Mobility

Paul J. Judge, Major, USAF

June 1998

Approved for public release; distribution unlimited

## Acknowledgments

### **Family First**

There is not enough room on this page nor are there sufficiently eloquent words to describe the dedication and commitment of my wife Teresa. Her self-sacrifice has gone far beyond what should be considered reasonable and I shall forever be indebted. For my daughter Sawyer to spend her first year of life hoping to have just a little bit more time with Dad is so much to ask. Yet, it was her smiles, laughs, and hugs that always made everything seem all right. I thank them both for continuous love and support.

### **Professional Assistance**

Many people contributed to this research and have my sincere thanks for taking time out of their busy schedules. In particular, I would like to thank Lt Col James F. Jamison at USTRANSCOM for helping to get the ball rolling and then seeing it through whenever needed. Mr. Raymond Pyles of Rand Corporation for always responding with keen insight to all my e-mail and telephone questions. Thanks to Mr. Todd Carrico and the Advanced Logistics Program team at DARPA for extensive information. At the Air Force Institute of Technology, thanks to the faculty, staff, and my advisor, Dr. Craig Brandt, for all their help and constructive criticisms. Also, a special thanks to MSgt Yocasta Garcia and the Air Mobility Warfare Center staff for excellent support along the way. I hope the result satisfies all their expectations.

Paul J. Judge

## Table of Contents

	Page
Acknowledgments.....	ii
List of Tables .....	v
List of Figures.....	vi
Abstract.....	vii
Motivation.....	viii
I. Introduction .....	1
Theme .....	1
Scope.....	5
II. Literature Review .....	6
Background.....	6
General Issue.....	8
(Allen, 1997:111).....	10
Logistics Strategy.....	11
Still Room for DoD Improvement .....	15
III. Logistics Programs.....	17
Outsourcing.....	17
Information Management.....	24
IV. Real Time Information .....	28
Advanced Logistics Program Overview .....	28
The Four Grand Challenges .....	31
The Technology That Makes It Happen .....	42
V. Time Definite Transportation.....	52
General.....	52
Organic.....	53
CRAF .....	55
Other Issues.....	56

	Page
VI. Timeline Convergence.....	58
General.....	58
DLA at Work .....	60
VII. Conclusion and Recommendations .....	62
Conclusion .....	62
Recommendations.....	64
Bibliography .....	66
Vita.....	71

**List of Tables**

	Page
1. Davis and Drumm's Logistics Costs as a Percentage of Total Revenues.....	10
2. Fiscal Year 1997 Unified Supply Distribution System (DLA Depots) .....	20

## List of Figures

	Page
1. Planned Logistics Support Depiction.....	3
2. Prime Vendor Distribution Depiction.....	19
3. Baseline Repair Cycle Time .....	24
4. ALP End-to-End System View .....	29
5. ALP Goals.....	30
6. ALP Automated Logistics Plan .....	33
7. ALP Real Time Logistics Situation Assessment .....	33
8. ALP End-to-End Movement Control.....	37
9. ALP Implicit Plan Versus Desert Shield Deployment.....	38
10. ALP End-to-End Rapid Supply .....	40
11. Object Oriented Concepts .....	44
12. The ALP Cluster .....	46
13. ALP Cluster Elements.....	47
14. Design Use Cases.....	50
15. Transportation for the 3 <sup>rd</sup> ID from POD to TAA.....	50
16. Desert Storm Airlift Planning Factors Versus Actual Payloads .....	54
17. ALP Roadmap.....	59

**Abstract**

The Department of Defense (DoD) is entering a period of rapidly evolving logistic business practices and information management technologies. These rapid changes are largely the result of mandated inventory reductions set forth by Congress. Replacing DoD inventory with logistics process improvement and information systems is now a requirement rather than just a good idea. These efforts are well underway across DoD and are especially apparent at the Defense Logistics Agency (DLA) where programs like Prime Vendor, Direct Vendor Delivery, and Premium Service are turning just-in-case inventory into just-in-time inventory. However, the Advanced Logistics Program (ALP) headed by the Defense Advanced Research Projects Agency (DARPA) stands out among DoD logistics efforts as having the most potential to alter the supply chain in times of war and peace. Specifically, ALP is designed to establish real-time information connectivity across all logistics functions without rendering legacy systems obsolete. When the project is completed in 2002, ALP will rapidly generate courses of action that decision-makers can employ to ensure tailored logistics effectively supports fluid operations. This advanced logistics environment requires fast and dependable transportation. Therefore, DoD should examine the influence that ALP will have on the defense air transportation system. The full advantage of automated logistics information will not be realized unless air transportation is correctly structured.

## **Motivation**

“If we do not build a transportation system that can meet our needs tomorrow,  
then it won’t matter much what kind of force we have  
because we won’t be able to get it there.”

**General John M. Shalikashvili**  
**Chairman of the Joint Chiefs of Staff**  
**(USTRANSCOM HANDBOOK 24-2: 1997:21)**

“USTRANSCOM’s Vision: Providing timely, customer-focused global mobility  
in peace and war through efficient, effective, and integrated transportation  
from origin to destination.”

**(USTRANSCOM HANDBOOK 24-2: 1997:21)**

**THE POTENTIAL INFLUENCE OF  
ADVANCED LOGISTICS  
ON DEFENSE AIR TRANSPORTATION**

**I. Introduction**

**Theme**

Today, there are converging joint strategies on the conduct of mobility that will generate new methods of conducting business. The primary strategy is outlined in the Chairman of the Joint Chiefs of Staff's (CJCS) Joint Vision 2010 and is reflected in the Defense Planning Guidance. "At the heart of the Joint Vision 2010 are four emerging operational concepts: dominant maneuver, precision engagement, full dimensional protection, and focused logistics" (Fogleman, 1996). This fourth concept will afford DoD enormous efficiencies while maintaining the worldwide global engagement and logistical sustainment critical to future operations. The objective of this study is to review forthcoming DoD logistic practices and then select and examine one program with the greatest potential to change or influence the conduct of air mobility operations.

There are a vast number of projects and programs underway in DoD to overcome the varied logistics problems so prevalent in Desert Shield/Desert Storm (Figure 1). The over shipment of goods to the Gulf, the complete lack of visibility over the assets and the expansive amounts of expensive inventory stateside highlighted a need for change. In its high risk series of investigations, the GAO complemented the DoD on reductions in inventory but stated that unless more aggressive action was taken, the inventory

management problems would continue into the next century (Peters, 1997:43). If this forecast turns out to be true, the expense would likely be applied to the DoD budget and possibly jeopardize full funding of weapons modernization, infrastructure improvements, and personnel issues. Congress is keenly aware of these inefficiencies and has purposefully reduced DoD budgets accordingly (Mattern, 1997:8). "Between 1989 and 1996, the Congress reduced DoD's procurement and operations and maintenance budgets by about \$7.5 billion to prevent the acquisition of unneeded inventory and to encourage DoD to improve its inventory management practices" (GAO-HR-97-5, 1997:n. pag). "In the seven years between 1996 and 2003, the Air Force is supposed to reduce its inventory value by another \$11 billion. By 2003, ... the value of the Air Force inventory is supposed to be half of what it was in 1992" (Mattern, 1997:8). However, the AF is finding it difficult to achieve these mandated reduction objectives. In short, without significant strides in focused logistics, the Air Force may not achieve its reduction targets and, thus, fail to fully develop the first three operational concepts.

One important lesson learned from inventory reduction efforts is that process variation must be identified, controlled, and usually reduced. In other words, in order to replace inventory effectively with just-in-time business practices, statistical process control must be implemented to overcome special and common causes of variation. In simple terms, special causes of variation relate to problems induced by an uncontrolled process and common causes of variation involve the capability limitations of equipment. Thus, a more aggressive action plan that responds to inventory reduction requirements can occur on two levels. First, DoD could dedicate professionals to continually improve current inventory management processes to eliminate any special causes of variation.

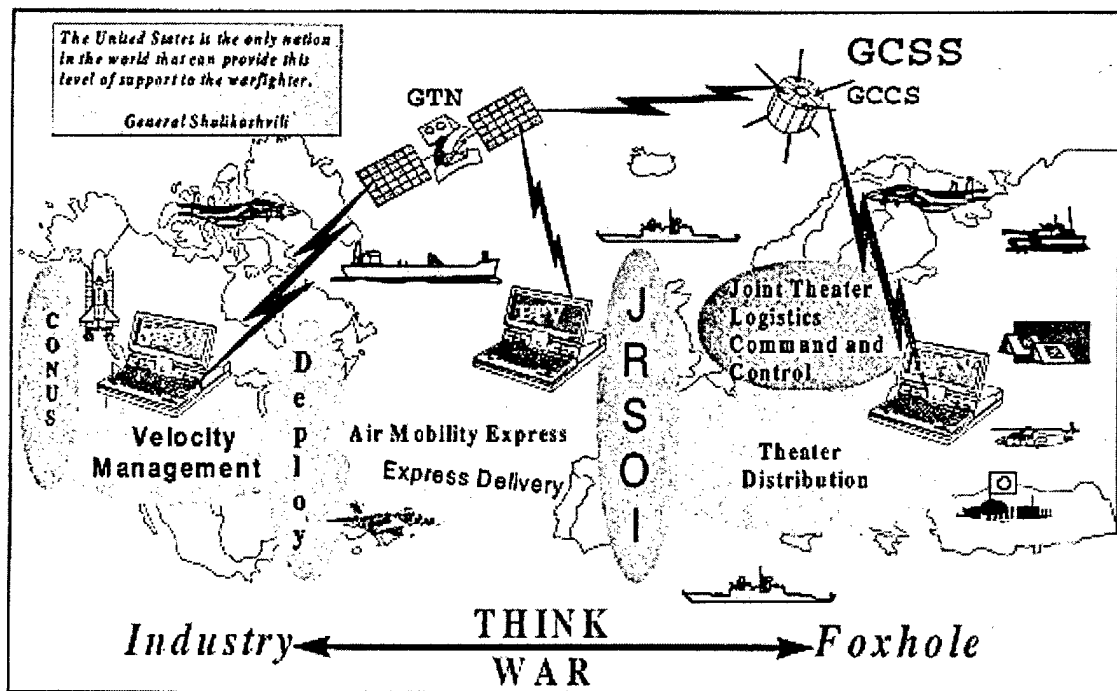

Figure 1. Planned Logistics Support Depiction (Cusick, 1997:27)

Training and communication lines are already cutting across services and the personnel are in-place to gain higher levels of control over logistic functions. “We know we can work more efficiently, and most importantly, we have the opportunity and high-caliber people to make a genuinely evolutionary change in how we do business” (Cusick, 1997:26). Second, DoD could insert new or existing technologies that will reduce common causes of variation. Although sometimes expensive and risky, new automation techniques (such as information management) have proven themselves invaluable in both public and private sector operations. Failure to correctly achieve this second objective may very well restrict DoD from accomplishing necessary logistic efficiencies in a timely manner.

Without improved automation of logistics information, a shift in appropriations from inventory management toward weapon system modernization would be undermined. Fortunately, the needed technology exists today. "The major limits on exploiting long-available technologies are not inadequate research and development and procurement, but rigid and parochial organizational systems within and among the military services" (Odom, 1997:57). Indeed, the full integration of DoD automated logistics systems to provide a central clearing-house for end-to-end planning, execution, and sustainment is available. Getting it to the field is more critical in this fiscally constrained environment than ever before. If a joint, DoD-wide, single system solution exists, it should be endorsed by all participating agencies.

The impact of a single information system on the transportation function of logistics is predictably significant. Tighter control over inventory means fewer assets are needed on hand and in the pipeline to satisfy demand. However, a higher frequency of smaller, faster shipments is required to leverage the full potential of real-time information. DoD continues to expand its use of commercial carriers to resolve efficiency issues between transportation modes and the requirements of just-in-time business practices. However, a rapid expansion in logistics information technology may catch transportation managers off guard. In other words, the future transportation force structure should be ready to properly interface with advanced logistic information capabilities. For example, advanced logistics will seek to minimize asset in-transit time to save on overall inventory requirements. Thus, efficiently matching airlift resources (organic or commercial) with smaller and more frequent CONUS cargo loads may be increasingly essential in meeting the demands of many customers. Although the ultimate

goal is to strike a complementary balance between logistics and operations, DoD is entering a period where rapidly emerging logistic technologies and business methods may drive a reorientation of defense air operations.

This study will examine the potential influence that the Advanced Logistics Program (ALP) could have on air transportation. In an effort to understand the general business direction of DoD logistics, a few key inventory management programs will be reviewed. From this point, ALP will be examined in depth in order to validate its potential to enhance logistics control and impact air movements. Finally, some suggestions as to how and when the air transportation component of the DTS can expect change will be offered.

### **Scope**

The scope of this study entails the review of some leading DoD logistics programs and strategies designed to reduce inventory and resolve logistic inefficiencies. This research is tailored to understand if possible influences on the conduct of future air transportation exist.

## II. Literature Review

### **Background**

The defense build-up of the 1980's marked the peak of Cold War escalation and culminated in the failure of the USSR. One unwieldy consequence of this rapid shift in world balance of power was a massive DoD inventory that was, for intents and purposes, unneeded. In addition, the US deficit was enormous and took center stage on the political front. There was very little disagreement that the military could be downsized and multi-layer inventories brought under control. However, before any significant progress could be made, Iraq had invaded Kuwait and America was at war.

The logistical accomplishments during the Gulf War were record setting. "By the sixth week the total ton miles flown surpassed that of the 65-week-long Berlin Airlift" (Matthews, 1996:12). Secretary of Defense Cheney termed the deployment "a logistics marvel" and General Schwarzkopf called the results "spectacular" (Matthews, 1996:12). Although this strategic movement may never be duplicated, some serious logistics problems that have far reaching implications were identified. "One of USTRANSCOM's most intractable and high-visibility problems during Desert Shield/Desert Storm was a backlog of sustainment cargo at aerial ports of embarkation, primarily in the United States" (Matthews, 1996:84). Besides the large volume of cargo and frequent changes to movement priorities, computer-processing capabilities also inhibited shipment flow. "Automated databases processors and procedures often could not reliably keep up with frequent changes made to the requirements" (Lund, 1993:74). The process was broken at destination points as well. Users could not easily find their supplies because of the

excessive amounts arriving and the overall lack of traceability. “Half of the 40,000 bulk containers shipped into the theater had to be opened in order to identify their contents, and most of it failed to contribute in any way to our success on the battlefield” (Muczyk, 1997:89). In essence, a claim of superior logistics achievement based on the tonnage of cargo delivered over a given time period is misleading. Compensating a lack of logistics management and control with oversupply of assets is a more difficult and expensive way of doing business. These occurrences altered the way DoD viewed its logistics processes.

For many Americans, the end of the Cold War and success in the Gulf finally meant that a “peace dividend” could be realized and applied toward the deficit or many ignored domestic issues. Government downsizing policies and regulatory guidance set the tone for all agencies. For example, the Government Performance and Results Act (GPRA) of 1993 required “federal agencies, including DoD as a total entity, to develop strategic plans no later than September 30, 1997” (GAO-97-28, 1996:n. pag). However, lessons learned from Desert Shield and the US response to Bosnia motivated new ideas and methods of supporting operations ahead of the GPRA schedule. “In fiscal year 1994, DoD developed a logistics strategic plan, which it has updated annually, to provide an integrated logistics roadmap to support its warfighting strategy” (GAO-97-28, 1996:n. pag). Some of the specifics of the plan reveal important trends that will require future commanders to approach deployment and sustainment differently than their predecessors. “Its current plan states that DoD is striving to cut secondary inventories from the current \$70 billion to \$53 billion by October 2001, or about 24 percent, and occupied storage space from 631 million cubic feet to 375 million cubic feet or less, or about 40 percent” (GAO-97-28, 1996:n. pag). The plan also includes objectives to reduce logistics

response times, develop a seamless logistics system, and achieve a lean logistics infrastructure (GAO-97-28, 1996:n. pag). While the plan is broad in scope, one particular principle cuts across all efforts and is essential to enabling reduction goals. The “need for real-time information on material and logistics support capabilities” (GAO-97-28, 1996:n. pag) is the key process element that can tie all other functions together so that reductions in inventory and infrastructure do not threaten a commander’s readiness.

Recent studies concerning modern defense logistics all reveal or support a few fundamental truths. First, a unified Department of Defense (DoD) logistics strategy that is reflected in joint and service doctrine is required immediately. Second, to effectively manage and reduce inventory, a near real-time information system that cuts across all logistic functional areas and is not excessively dependent on manual entry for raw information is a necessity. Third, transportation modes must reduce in-transit time and achieve reliable, time-definite delivery capability. While the first and third of these truths are largely process improvement efforts, the real-time logistics information system demands technology insertion. Assessing the feasibility of acquiring such a system should assist DoD in forecasting future transportation requirements and estimating changes in organizational doctrine.

### **General Issue**

One of the classic tradeoffs in logistics is between transportation and warehousing. On the surface, the financial exchange seems quite simple. Moving large quantities of inventory (per shipment) that are unconstrained by time usually yields a less

expensive per unit transportation cost. Therefore, a company can build warehoused inventory until a point where transportation costs are minimized. Of course, this approach isolates the decision from the many interlocked facets of logistics. For example, customer service may suffer if the suppliers transportation profile requires large orders and, thus, additional storage requirements at destination. If customers are dissatisfied, sales may decrease. Today, it is generally accepted that a more systematic approach toward logistics costs is needed. "The logistics costs of a typical firm entail transportation, inventory carrying, customer service, order processing, warehousing, package, information or data costs associated with the foregoing, and administration of the logistics function" (Allen, 1997:110). As depicted in Table 1, "the total of warehousing and inventory carrying costs is slightly more than transportation cost" (Allen, 1997:111). Calculating that a tradeoff is beneficial without full consideration of the entire logistics system normally sub-optimizes costs. This has been airlift's position all along. "Since no one would choose air on the basis of its transport rates alone, air had to argue that, from a total cost perspective, it was cheaper than alternative modes" (Allen, 1997:113). That is, although faster transportation is more expensive, the ability to diminish warehousing costs, carrying costs, and in-transit times improved overall costs. "A survey of purchasing managers showed that 20 percent had made changes in their patterns of buying the transportation needed to move inbound products. Some moved from rail to truck or from truck to air – in many cases to meet the speedier delivery needs of just-in-time inventories" (Wood, 1996:346). Premium transportation continues to expand its role as a cost-effective substitute for inventory.

**Table 1**  
**Davis and Drumm's Logistics Costs as a Percentage of Total Revenues**  
 (Allen, 1997:111)

Logistics Component	Percentage
Transportation	3.53
Warehousing	2.10
Carrying Cost	1.70
Customer Service or Order Processing	0.44
Administration	0.39
Total Distribution Cost	7.94

Note: Percentages do not add to total because not all surveyed firms responded.

As more and more organizations have embraced logistics as a complete system and subsequently moved toward faster transportation, other inventory substitutes have emerged with significant potential. "There is a large opportunity for improving logistics response times in the department (DoD) today. We need to think in terms of substituting fast transportation and real-time information for layered inventory as a strategy for improving logistics response times" (Kaminski, 1996:2). "For the past 50 years, the information and technology part was looked at as an adjunct to the transportation process. In the next 50 years, and it has started already, the information flow will be as significant a product of the transportation process as the transportation itself" (Drucker, 1994:28). Real-time asset information has been instrumental in reducing inventory for the private sector. In conjunction with other best business practices, such as limited partnerships and reduced cycle times, real-time information enabled Schneider Logistics to trim one customer's inventory by 33 percent in just 15 months (Sur, 1995:32). For DoD, establishing a real-time information system that is fully interactive down to the unit level is occurring in a three-step manner. First, there is Intransit Visibility (ITV) which gains control over the pipeline from when assets begin to move until they reach a designated

destination and stop moving. The second step is Total Asset Visibility (TAV). “If you add your knowledge of what is in the transportation pipeline information on what is in storage at the vendor or at DoD warehouses, and information on things while they are in use, including maintenance, then you have Total Asset Visibility” (McHugh, 1994:30). Finally, the third step is to fully integrate all defense logistics information systems into one system to overcome incompatibilities and the parochial nature of legacy systems. The need is for a real-time logistics management system that is interactive with decision-makers concerning the end-to-end movement and availability of assets. Although a daunting task, DoD inventory and logistics programs are already moving in a direction that will require such capability.

### **Logistics Strategy**

Doctrine and strategy are fundamental in understanding the course that military logisticians are planning and the eventual capability that will influence methods of operations. “Military doctrine describes how a job should be done to accomplish military goals; strategy defines how it will be done to accomplish national political objectives” (AFDD-1, 1997:4). The multiple layers of strategy range from National Security Strategy, National Military Strategy and Defense Planning Guidance to unit level plans. Today’s emerging service logistic strategies are rooted in the DoD Logistics Strategic Plan (DLSP) and Joint Vision (JV) 2010. The seamless logistics strategy in the DLSP emphasizes information flow resulting from integrated logistics information systems (Zorich, 1996:3). JV 2010’s Focused Logistics concept “requires a combination of information and logistics technologies that ensures required supplies arrive at the right

time at the right place every time, no matter the level of conflict” (AFDD-1, 1997:38). These guiding plans are supported by initiatives in each military service. “Through Army’s Velocity Management, Navy’s Expeditionary Logistics, Air Force’s Lean Logistics, and the Marine Corp’s Precision Logistics, efforts are underway throughout the department to reduce cycle times and improve responsiveness to user requirements” (Emahiser, 1997:2). At least one common theme exists within current defense logistics strategies. That is, reduce excessive inventories and deployment requirements by consistently delivering commodity and repairable support to customers in times of war or peace. Furthermore, use automated information exchange technology and relational databases to enable these strategies. Constant control of assets in the dynamic environments of military engagement or peacetime operations is a central requirement in post-Cold War defense doctrine and strategy.

As expected, the Air Force’s leading strategy espouses the same fundamentals as national and joint strategy. For example, one of the Air Force core competencies is Agile Combat Support. Among other elements, Agile Combat Support requires time-definite deliveries and advanced information technology in order to be successful (Global, 1998:n. pag). “Time-definite deliveries will form the basis for all resupply in the theater, thus reducing total lift requirement” (Global, 1998:n. pag). In addition, “information technology must be leveraged” if logistics support efficiencies are to be realized (Global, 1998:n. pag). An important concept of Agile Combat Support that accounts for reduced inventory initiatives and decreasing defense infrastructure around the world is the “reach-back” approach. “When combat commanders require an item, the system will reach back to the continental United States and deliver it where and when it is needed” (Global,

1998:n. pag). Of course, increasing continental United States (CONUS) based supply also increases the pressure on fast transportation modes to deliver over greater distances. Simply reducing the maximum acceptable in-transit times may not adequately support the war-fighter. Practical matters such as manufacturing lead times, transshipment node reduction, and continuous asset visibility must be addressed first. In other words, a superior information system controlling assets and the efficient movement of materials through a shortened overall supply pipeline is essential. It is a deeper integration of Agile Combat Support and its core competency brother, Rapid Global Mobility, by using technology insertion and process improvement that will produce financial savings. This basic strategy has been converted into operational programs under Lean Logistics.

Air Force Lean Logistics strategy and initiative is Agile Combat Support in the making. "The goal of the Lean Logistics program is to change the supply system from relying on more parts to relying on speed of response" (Mattern, 1997:8). More specifically, the "goals are (1) to reduce logistics response time, (2) develop seamless logistics systems and (3) streamline the logistics infrastructure" (Zorich, 1996:2). The success of Lean Logistics is dependent on a wide range of efforts such as depot repair enhancement program (DREP), door-to-door distribution (D3), and cargo movement operations systems (CMOS). However, the entire strategy will ultimately require comprehensive information control as reflected in the Lean Logistics Master Plan and Road Map.

The key support concept for Total Asset Visibility (TAV) is to have it for all organizational levels within the Air Force. Together with a functioning information management/Log C3 system, decision makers can evaluate asset status (near) real time and redirect assets as required to support operation units. HQ AFMC has developed a TAV concept of operations

along with the other services and DoD. Final decisions about that structure have not yet been made. (LLMP, 1996:9)

Delivering an end-to-end TAV system that operates real time is a difficult challenge especially with so many individually developed sub-systems that are unlikely to function together. TAV may not go far enough to support Lean Logistics. If it results in a tracking system only and does not provide interactive problem solving tools, then planned efficiencies may not be realized. Some studies point to potential degraded performance of logistics support as inventories are reduced in expectation of improved process control under Lean Logistics (O'Malley, 1996:1). While these type studies may be correct in the short run, they tend to overlook potential technological insertions and significantly improved asset control. As has been shown in the private sector, converting just-in-case inventory to just-in-time inventory is heavily dependent on automated asset control systems. This conversion also requires time-definite distribution and, appropriately, the Lean Logistics Master Plan emphasizes the need for "reducing variability in the pipeline in-transit times" (LLMP, 1996:10).

In contrast to traditional defense transportation systems that depend on node-intensive, intermodal means of moving commodities, lean, just-in-time delivery of critical assets requires door-to-door delivery to minimize handling and transfers between different operating and information systems. A key strategy to successful logistics operations is simplifying the system through node reduction and process reengineering. Premium transportation services provide that seamless flow from shipper directly to the end user. (LLMP, 1996:10)

The USAF Baseline Lean Logistics Master Plan and Road Map outlines many simultaneous efforts and programs that are needed to maximize the effectiveness and efficiency of DoD support. Real-time information and time-definite delivery stand out as

the two critical variables necessary for maintaining unit readiness while achieving significant inventory reduction goals.

### **Still Room for DoD Improvement**

Air Force Lean Logistics operationalizes Agile Combat Support which directly supports the vision of JV 2010 and the objectives of the DLSP. The approximately 100 initiatives associated with the 1994 initiation of Lean Logistics have established a firm foundation for the program (Brunkow, 1996:186). However, there is still much room for improvement. “The average 36 days that it takes to fulfill a customer order is simply not good enough in a world of overnight, need-it-now logistics” (Privratsky, 1997:15). If one day CONUS delivery and three day OCONUS delivery are DoD goals (Pyles, 1998a), then aggressive measures are needed to reduce in-transit times ahead of scheduled inventory reductions. “An average of 11 days for in-transit in the continental United States, given an industry average of three days, is unacceptable now and will become even less tolerable in (the) future” (Privratsky, 1997:15). In addition, decreasing in-transit time represents a large portion of potential savings that can be used to modernize the force. “Each day we take out of the transportation portion of the pipeline will save us about \$22 million in inventory” (Saunders, 1997:15). A superior logistics system with interactive solution capability is what will enable any gain in effectiveness or efficiency. The need for real-time logistics is supported by the “Logistics 2025” research team. The Battlespace Responsive Agile Integrated Network (BRAIN) concept proposes the extensive connectivity of computer logistics systems to support just-in-time strategies

(Edgell, 1996:13). Of course, due to budget pressures, commanders cannot wait 27 years. They need results near-term.

Occurrences of reduced inventory efforts proceeding viable information control and fast transportation substitution exist today. These situations can compromise military operations. For example, the Air Force reduced aircraft spare parts inventories based upon requirements developed with respect to projected process improvements under lean logistics. In fiscal year 1997 “the Air Force was expected to improve its average retrograde and pipeline speed from 63 to 52 days...just to stay even with funding for spare parts stock level policies” (Air, 1998). These savings have not completely been achieved and Air Mobility Command’s aircraft mission capable rates have decreased (Air, 1998). By fiscal year 1999, the spare parts pipeline must decrease to 36 days in order to offset budget reductions (Air, 1998). While a large part of the current problem stems from under funded depot repair capabilities, it is premature inventory reductions that are the root cause. Fiscal year 1997 repair parts funding (includes both purchase and maintenance costs) was only 81% of the requirement (Air, 1998). In short, savings were taken too soon. Although DoD has embarked upon a course to avoid this type of shortfall in the future as reflected in logistics strategy such as lean logistics, the implementation is lagging. Putting the information management and time-definite delivery strategy into operation at a rate that is commensurate with reductions in inventory are key factors in maintaining defense readiness. This can only be fully accomplished by merging existing information systems into a single control mechanism and adjusting premium transportation to move small loads directly and more frequently. This effort seems achievable over the next few years.

### III. Logistics Programs

#### **Outsourcing**

The DoD is implementing a multitude of programs aimed at reducing inventories as necessitated by budgetary constraints. In the near-term, independent units, divisions, and services are finding ample cost reduction opportunities to pursue. However, long-run planning calls for unification of commercial and government logistic systems across the entire life-cycle of goods. "The cornerstone of this blueprint consists of a seamless logistics system that blurs the distinctions between civilian and military specifications, practices, and responsibilities; between domestic and foreign goods and services; and between active duty and reserve or national guard" (Muczyk, 1997:11). Potential financial benefits from operations that support the focused logistics strategy are enormous. On its own, "the Air Force is expecting a \$4 billion savings from lean logistics" (Muczyk, 1997:10). Service efforts will provide the greatest level of return if conducted in a manner that incorporates programmatic trends of the Defense Logistics Agency (DLA). "DLA has adopted best business practices to reduce delivery time, save money and tailor our support to individual needs" (Privratsky, 1997:15). This is critical because DLA purchases and supplies "89 percent of the total number of items used by the Defense Department" (Distribution, 1998:n. pag). In addition, wholesale management of most consumable items is being transferred to DLA (GAO-NSIAD-96-70, 1996:n. pag). Three DLA examples leading the revolution in DoD logistics management are Prime Vendor, Direct Vendor Delivery, and the Premium Service Program. These initiatives

represent important third party outsourcing process changes that logistic planners must account for if future savings and readiness goals are to be achieved.

The fastest way for DoD to leverage the best inventory business practices is to transfer management of many commodities to the commercial sector. While studies and opinions have warned about potential escalating costs associated with poorly planned outsourcing, the projected benefits normally outweigh future costs. "Prime Vendor eliminates the layering of supplies at multiple echelons and shifts inventory, inventory management, transportation, and personnel costs from the government to commercial firms" (Velocity, 1998:4). The advantages of Prime Vendor have been made possible by evolving technologies. "The 1994 Federal Acquisition Streamlining Act established a 1997 deadline for implementing the use of electronic commerce government-wide" (Velocity, 1998:4). Electronic data interchange (EDI) operations have integrated government and commercial computer systems in order to reduce inventory nodes and, simultaneously, improve service to the customer. Consolidating a DoD warehouse and a retail warehouse into one prime vendor operation is the fundamental event that reduces various logistics costs (Figure 2). The value of integration with commercial procurement is significant and has further room for growth. According to Robert L. Molino, Executive Director of Procurement at DLA, DoD will have world-wide access to inventory information when Virtual Prime Vendor is fielded (DLA, 1997). Virtual Prime Vendor is total logistics support including anticipatory inventory control that enables suppliers to properly schedule manufacturing lead times. DLA reengineering efforts are also developing electronic catalogs, corporate catalogs, and electronic malls on the internet.

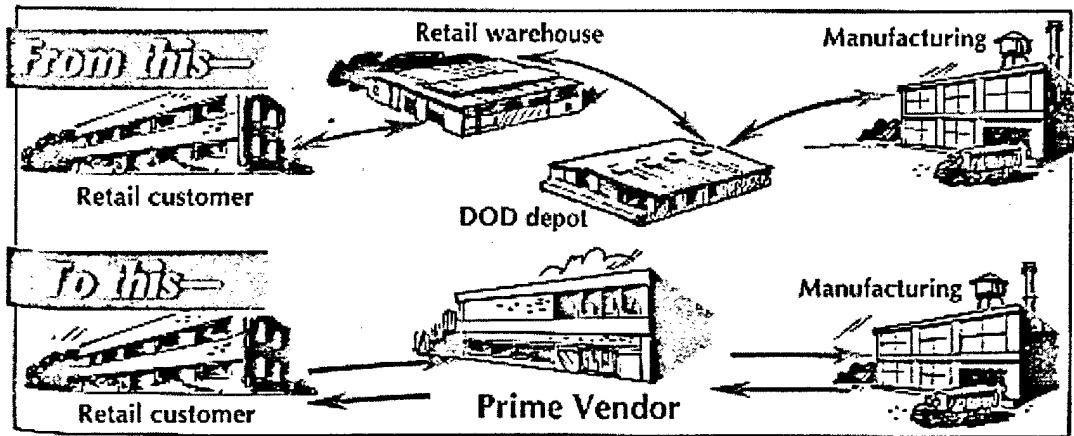

Under DLA's Prime Vendor program, a contractor assumes the role of Defense depots and Army warehouses in supply distribution. The inventory, inventory management, personnel, and transportation costs previously borne by the Government also shift to the contractor.

**Figure 2. Prime Vendor Distribution Depiction (Velocity, 1998:5)**

In short, the Prime Vendor Program accomplishes three important steps in supporting defense logistics strategies. First, it decreases inventory management redundancies by combining government and commercial business opportunities. Second, Prime Vendor leverages government buying power by grouping similar commodities across all services. Third, the program enlarges electronic information exchange capabilities that can further increase inventory efficiencies and asset visibility. Once Prime Vendor obtains process control over some select commodities, these methods of unit support can be expanded for more savings. Inevitably, Prime Vendor will develop completely into Virtual Prime Vendor where process management and electronic information can combine for greater inventory efficiencies.

Direct Vendor Delivery (DVD) takes inventory node reduction another step further. While many commodities and parts are efficiently controlled by prime vendors, intermediate control points, and DoD depots, "certain items lend themselves to delivery directly from the vendor to the customer" (Distribution, 1998:n. pag). For example, DoD

uses a direct vendor delivery program for medical commodities that bypasses the government warehousing and distribution system. Incredibly, DoD can achieve savings of 25% if the direct vendor delivery program expands to all commodities (Phillips J., 1996: 13). “DLA is maximizing direct vendor delivery wherever commercial sector inventories are sufficiently robust to support both peacetime and wartime surge requirements” (Distribution, 1998:n. pag). Based on the inventory maintained by DLA depots under the unified distribution system (Table 2), designating assets as DVD products still has enormous room for growth.

**Table 2**  
**Fiscal Year 1997 Unified Supply Distribution System (DLA Depots)**  
(Distribution, 1998:n. pag)

<b>Category</b>	<b>Amount</b>
People	13.500
Assets/Items	5 million
Inventory Value	\$101.9 billion
Transactions	27.3 million

One example outside the medical commodity realm is taking place in the Army’s Tank-automotive and Armaments Command (TACOM). “For its first application of Direct Vendor Delivery, TACOM chose the high mobility, multipurpose, wheeled vehicle’s bias-ply tire. Immediate payoffs came in the form of less paperwork, shorter administrative lead times, and reduced personnel costs associated with processing each requisition” (Velocity, 1998:6). DVD is a simple contract between a supplier and customer that specifies expected usage rates, delivery criteria, and other particulars needed to by-pass government intermediate processes altogether. TACOM now has bias-ply tires being delivered direct to field units when needed. Government overhead, inventory management costs, and transshipment delays are all reduced.

The Defense Supply Center-Richmond (DSCR) has statistically recorded the positive results of DVD. "By using Direct Vendor Delivery, from fiscal years 1993 to 1996 DSCR was able to improve demand satisfaction from a cumulative rate of 85.4 percent to 90 percent and reduce inventories by 15 percent, procurement lead times by 30 percent, and backordered lines by over 20 percent" (Velocity, 1998:6). However, DoD has only scratched the surface of converting on-hand inventory into DVD inventory. In 1997 these initiatives represented only "3 percent of the items for which this concept could be used" (GAO-HR-97-5, 1997:n. pag). Moreover, a sizable portion of the inventory reductions could be attributable to force level reductions that, in turn, reduced overall demands on DoD logistics (GAO-HR-97-5, 1997:n. pag). Nevertheless, DVD has demonstrated significant results in specific cases and can be applied to many more DoD resources. Of course, similar to Prime Vendor, DVD depends heavily on automated information systems for success. Accurate asset demand projections, instantaneous requisitions, paperless invoicing, and best cost transportation selection must all be possible. Continuing to use technology insertion to develop a user-friendly DVD program and increase customer confidence in a reduced inventory environment should defeat any lingering institutional resistance.

The Premium Service Program (PSP) also takes advantage of commercial capabilities and economies of scale. "Premium Service is a Defense Logistics Agency program that provides time-definite delivery by using a third-party logistics vendor" (Express, 1998:n. pag). Conceptually, the PSP aligns a DoD inventory facility with a commercial express air-carrier's hub and releases operations management to a contractor (usually the logistics branch of the air-carrier). In so doing, the government leverages the

expertise and business practices of a third-party logistics firm and significantly improves order and ship times. "Premium Service provides customers with guaranteed direct door-to-door delivery to a specific location within 24 hours within CONUS and 48 hours to most OCONUS locations after receipt of the order. The program gives the customer faster response times than usually provided by other DoD distribution systems" (Express, 1998:n. pag). PSP is a relatively recent initiative that is operating on a small scale in relation to the total DoD logistics requirement. The program focuses on consumables and reparableables that weigh less than 150 pounds and constitute a large percentage of overall DoD package traffic. However, when measured in terms of volume, these packages normally constitute less than 50% of movement requirements (Pyles, 1998b). PSP could expand its volume throughput. The 88,000 square foot facility in Memphis, Tennessee is operated by FEDEX Logistics Service and has the capacity to handle cargo up to 1500 pounds (Express, 1998:n. pag). Early PSP operations have contributed positively in reducing order and ship times and shrinking the overall logistics pipeline. Moving inventory at high speeds to the customer reduces assets in the pipeline and, thus, the overall inventory requirement.

However, investment in PSP may not have long term viability. An effective direct vendor delivery process combined with end-to-end air express service may achieve comparable cycle times and, therefore, eliminate a need for PSP facilities. DLA will have to address these issues as EDI enhancements change business practices and solidify partnerships with commercial vendors. Reducing inventory control points (depots and warehouses) is already in the DoD Logistics Strategic Plan. "In addition to significantly reducing its inventory since 1989, DoD has eliminated 38 distribution facilities, reduced

storage capacity by 42 percent and reduced depot personnel by 35 percent” (Emahiser, 1997:4). The Air Force will reduce its inventory control points from five to three in 2001 (Emahiser, 1997:4). Ultimately, PSP will probably work best for some supplies and DVD will work better for others. Manufacturing methods, inventory capabilities, and geographic locations will result in a wide-range of contracts to support US forces.

Prime Vendor, Direct Vendor Delivery, and Premium Service are all designed to support the DoD Logistics Strategic Plan. While each of the armed services also have logistics plans that support DoD goals, it has been recognized that these plans do not always mesh well with DLA programs. For instance, in a review of DoD logistics planning, the General Accounting Office (GAO) recommended that the Deputy Under Secretary of Defense Logistics “issue specific guidance to the Secretaries of the Army, the Navy, and the Air Force and the Director of DLA instructing the services and DLA on how to link their goals and budgets to the DoD logistics strategic plan’s overall goals and strategies” (GAO-NSIAD-97-28, 1997:n. pag). Tying prioritized goals and objectives to the appropriations and budgeting system is a traditional DoD problem. Too many departments have extensive plans competing for scarce resources and depend on DoD’s Planning, Programming and Budgeting System to provide the best funding solution. The Deputy Under Secretary of Defense Logistics response to GAO pointed to this very issue. John F. Phillips “explained that while his office is responsible for creating the streamlining plan, he doesn’t oversee its budgeting” (Traffic, 1997:32). In light of budget constraints, the probable course of action is to continue consolidating logistics planning, asset management, and life-cycle control within DLA. This is likely needed if the Air Force is going to achieve the 12 day baseline repair cycle time outlined

in the lean logistics master plan (Figure 3). The distribution goals embedded within this cycle time call for one day CONUS and up to three days OCONUS delivery capability, depending on distance (Pyles, 1998a). In the end, however, successful logistics outsourcing and management depends on a single integrated information system.

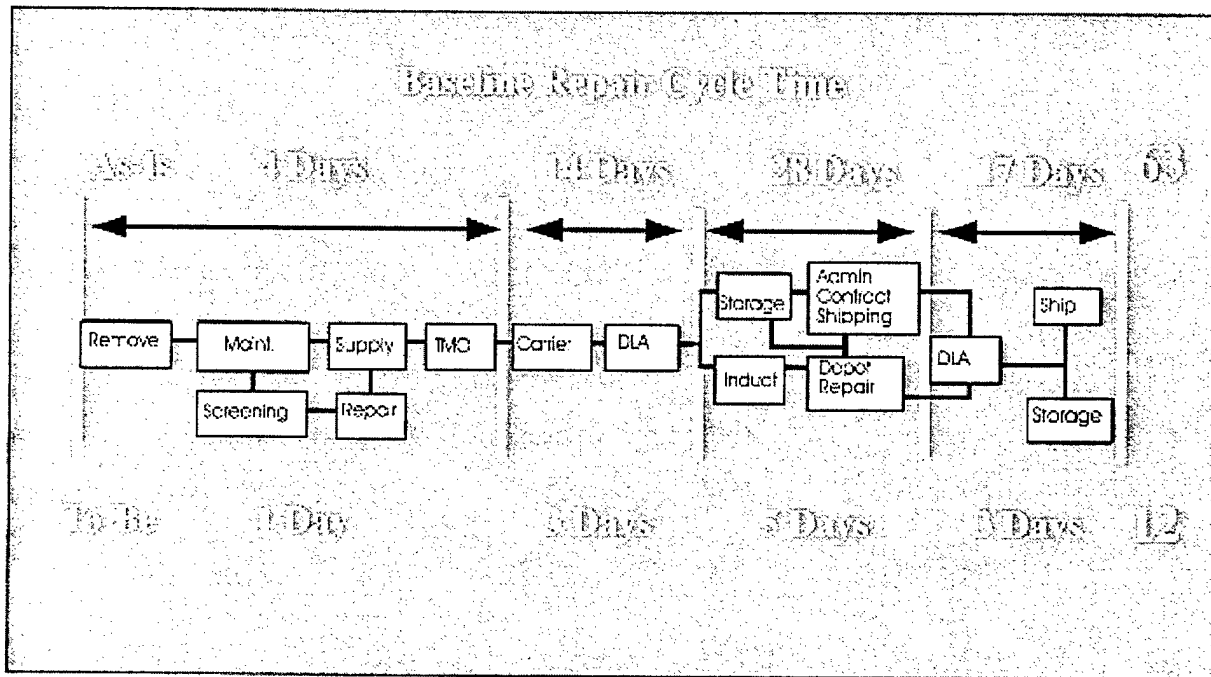

Figure 3. Baseline Repair Cycle Time (Hicks, 1996:7)

### Information Management

There is little disagreement that a single, standardized, and automated logistics information system is required in order to accomplish the other facets of logistics re-engineering. "A prerequisite to the achievement of the lean logistics environment required to support today's mission is the modernization of our current logistics information systems" (Kaminski, 1995:6). When it comes to Joint Vision 2010, a "judicious application of technological innovation and information superiority are billed

as critical enablers of the process” (Cusick, 1997:26). Of course, this is much simpler said than done. Units, commands, and services are using and developing systems that are not interoperable and DoD continues to struggle with implementing an overarching program. The single system concept is fairly clear but progress cannot keep pace with DLA’s outsourcing initiatives, separate service programs, and congressional timelines for inventory cost reductions. This disconnect is important because the warfighting commander demands visibility of assets and requires confidence in rapid availability. Without direct knowledge that commodities and reparable are available and capable of supply in a specified time period, the field commander is forced to stock-pile anticipatory requirements. To avoid overstated needs, there are a few major efforts underway aimed at establishing information management as a substitute for declining inventories.

As depicted in figure 1, the interaction of a hand-full of automated information systems can provide asset visibility. The goal of the Joint Total Asset Visibility (JTAV) system is to capture data on assets whether originating from manufacturing, a vendor, or a DoD facility and link that information to the end users. For oversight while an asset is in-transit, the Global Transportation Network (GTN) is being developed to track progress and estimate port arrival time. “Supporting the entire network from source of supply to point of need will be the Global Command Support System (GCSS). GCSS is designed to do for the logistician what the Global Command and Control System (GCCS) does for the operator. GCSS will facilitate access to critical resource data anytime, anywhere, throughout the world, and not require a specific hardware suite to make it all happen” (Cusick, 1997:26). Unfortunately, like many information systems, JTAV and the in-transit visibility (ITV) provided by GTN are “ultimately dependent on CIM (corporate

information management) migration systems to help it provide timely, accurate information on the location and movement of personnel, equipment, and supplies” (GAO-NSIAD-97-28, 1997:n. pag). “According to DoD’s plan, CIM’s milestones have been extended an additional 5 years because of operational difficulties” (GAO-NSIAD-97-28, 1997:n. pag). For example, decreasing GTN’s network of systems from over 100 to approximately 23 is moving slowly relative to DoD inventory reduction schedules. In addition, “the elements of Joint Reception, Staging, Onward Movement, and Integration (JROSI), Theater Distribution, and Joint Theater Logistics Command and Control have yet to be finalized...” (Cusick, 1997:26). Meanwhile, fragmented efforts continue in support of the total asset visibility goal.

To enhance Total Asset Visibility, the Defense Distribution Standard System (DSS) has been implemented at 11 wholesale distribution depots. DSS provides enhanced tools for improving asset accuracy and control, improves the operating efficiency of depots, supports in-transit Total Asset Visibility by allowing use of automated information technology devices, from bar codes to radio frequency tags and optical memory cards, to continuously update the Joint Total Asset Visibility database. By September 1998, DSS will be deployed in all wholesale distribution depots. (Emahiser, 1997:3)

The number of programs seems infinite and eventually they must all conform to a standard such as Milstamp or EDI standard data. The Air Force Lean Logistics Master Plan alone requires automation linkage for the Cargo Movement Operations System (CMOS), Automatic Induction System, Air Mobility Express (AMX) service, and several shop-level tracking systems (LLMP, 1996:11). “Much of the pipeline data is collected from the Advanced Traceability and Control for Air Force (ATAC-AF) system” (LLMP, 1996:15). Automating logistics within DoD is still a story of redundancy between services and agencies which results in prohibitions to integration and interoperability.

The complex task of obtaining real-time information is enormous. Achieving interim, fragmented progress is commendable because this is the traditional path that awkwardly leads to unified advancement. However, budget constraints, inventory reduction, and the implementation of commercial business practices will not allow the luxury of slow and separate progress. Aggressive action must be taken. Unless a single system capable of delivering the necessary communication links and user friendly decision support tools is put into place over the next few years, true focused logistics will not come to fruition. Without true focused logistics, weapon system modernization and warfighter readiness are seriously jeopardized.

#### **IV. Real Time Information**

##### **Advanced Logistics Program Overview**

Achieving DoD-wide control over the entire logistics pipeline (manufacturing to disposition) using one common automation tool is becoming more and more essential in terms of military preparedness and financial responsibility. The US military is moving from a forward based, just-in-case, big footprint, type of infrastructure to a CONUS based, just-in-time, reduced footprint, defense force. "To facilitate this shift in requirements, the Defense Advanced Research Projects Agency (DARPA) is developing new technologies to better manage material needed to move and supply troops and keep operations running smoothly" (Peters, 1997:42). In other words, the inefficiencies levied upon DoD by automated logistics systems that are developed independently and are not interoperable can no longer be tolerated. This is not to imply that current systems need replacement. Instead, the progress of logistics information systems developed along service and command lines needs to be captured and integrated into a single overarching system.

DARPA's Advanced Logistics Program is not a new DoD inventory tracking system written in its own code as a substitute to standing systems. Rather, ALP is designed as an overlay logistics information system that ties together existing and planned systems, databases, procedures, policies, and assessments to support real-time logistics decision making. ALP is designed as an end-to-end system that links operations and logistics (Figure 4).

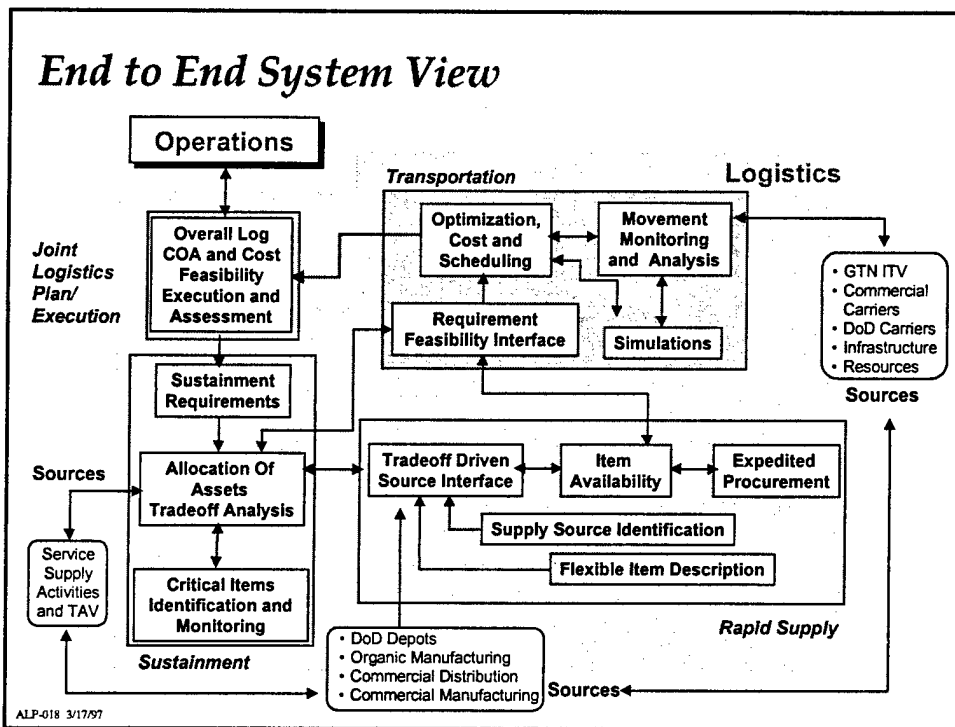

Figure 4. ALP End-to-End System View (ALP Overview, 1997)

ALP – a multiphase program – will culminate in the demonstration of a complete, end-to-end, factory-to-foxhole, multiechelon, prototype system across all functional areas. These areas include force generation, sustainment, transportation and rapid supply to support continuous planning, execution monitoring and rapid replanning of a major deployment from the continental United States to an in-theater final destination. (Defense, 1997)

The effort represented by ALP, if successful, will establish the asset management mechanism required in the reduced inventory future that is mandated by Congress. “The program addresses shortcomings of existing logistics support systems and seeks full development of significantly improved capability” (Advanced, 1998:n. pag). For example, ALP targets the limitations inherent in the Time Phased Force Deployment Data (TPFDD) process. The TPFDD is not flexible in circumstances consisting of continuous change in movement requirements and does not provide decision-makers with viable courses of action in those situations. This is often identified as a leading cause of inefficient use of airlift assets and improper support to warfighting units. As experienced

during the Gulf War, incorrect or excess inventories were delivered to staging points or into the theater because the TPFDD plan could not adjust to “real-time” requirements. Beyond deployment, ALP’s real-time information also manages sustainment. Gone are the days when a unit can reorder a commodity or reparable because the location of the originally ordered item is unknown. Commanders must know where needed assets are in the supply system and when they will arrive. Otherwise, redundant requisitions and excess orders will occur. This is critical because DoD is quickly becoming resource limited (downsizing and inventory reduction) and will continue to be airlift limited. In addition, “defense logistics material management methods, procedures, and supporting automated systems have not kept pace with advances in information management technology” (Advanced, 1998:n. pag). The installation of a logistics information system that provides extensive connectivity between existing systems is now fundamental to DoD effectiveness.

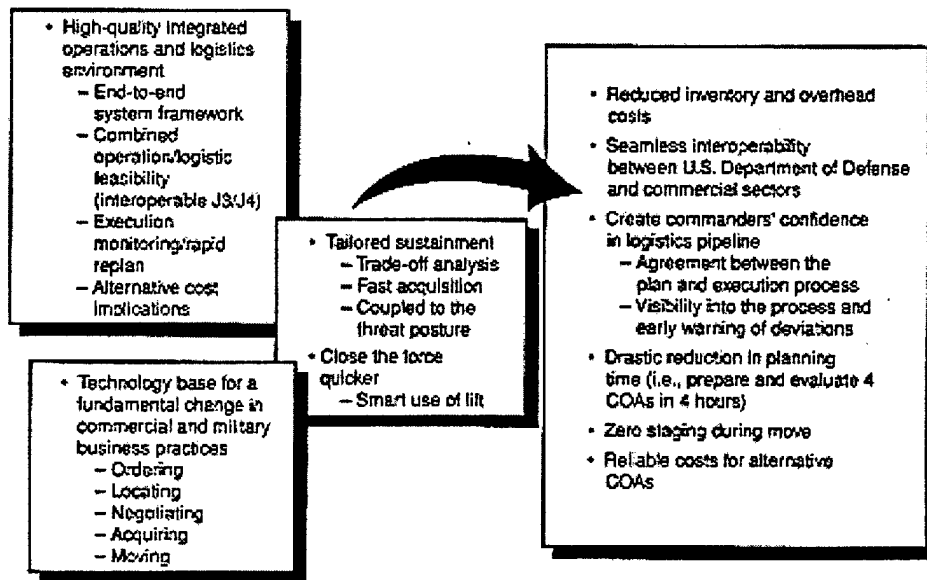

Figure 5. ALP Goals (Lynn, 1996:21)

In response, the DARPA-led ALP concept and related technology is being matured through the Joint Logistics Advanced Concept Technology Demonstration (JL-ACTD) effort and is endorsed by USTC and DLA (Jamison, 1997). The goals of ALP are fairly aggressive but necessary for successful operations in the new millennium (Figure 5). Further insight into ALP is available through the project's four grand challenges.

### **The Four Grand Challenges**

In order to implement the comprehensive logistics system envisioned by the DARPA and required by national military strategy, the ALP team has undertaken four grand challenges. These challenges are automated logistics plan generation, real-time situation assessment, end-to-end movement control, and end-to-end rapid supply (Defense, 1997:n. pag). Automated logistics planning evaluates logistics tradeoffs introduced by changes in requirements and updates the plan to a best feasible solution within minutes (up to one hour per course of action, COA). Meanwhile, commanders and movement personnel have a user friendly, information rich (five levels of detail) visualization of the pipeline through real-time situational assessment. End-to-end movement control tools continually monitor equipment and personnel to assure efficient use of transportation assets and avoid improper sequencing of demanded supplies. End-to-end rapid supply describes interoperability technology that links DoD agencies, commercial vendors, suppliers, and manufacturers so that inventories and cycle times can be reduced. Combining these four automated processes within one logistics system will provide a cost-effective substitute for government owned inventory and inadequate

logistics support to the warfighter. What this all means is that ALP's real-time information is an integration of existing automation technologies and defense computer systems to multiply the effectiveness of inventory reduction programs like Prime Vendor. In practical terms, ALP refines both deployment and sustainment flows so that operations are successfully supported with just-in-time inventory. Subsequently, savings from these modern inventory management practices can be applied to weapons modernization.

Today's TPFDD gives war planners a method of ensuring that expected unit movement requirements can be accomplished by available lift capacity and assists in determining closure. Unfortunately, the TPFDD does not handle dynamic environments well and is not designed to make COA recommendations to crisis action planning teams. Current operations seldom fit neatly into preplanned design and are often undefined in terms of logistics support until just hours before transportation arrives to move a deploying unit or sustainment goods. Determining movement requirements at this point is too late for current information systems to use transportation assets efficiently. Problems are just as pronounced after deployment. Units begin ordering just-in-case sustainment assets because they do not have visibility over the logistics support system. During Desert Storm "the actual material shipped grew in size without anyone's knowledge and certainly without any tools to predict the eventual impact. This caused a considerable waste of shipping resources and led to delays that rippled throughout the deployment" (Lynn, 1997:15).

The logistics planning function of ALP will automatically receive inputs from databases that are currently operating independently. These databases may include user procedures and policies, as well as requirements. This is not a one time electronic



information facilitates accurate and rapid decision making that is necessary for achieving high efficiency levels. A continually updating logistics plan makes better use of lift assets, avoids over saturation of ports, and establishes a critical baseline for leadership to reference before deciding upon a military action. The many DoD force closure and planning analytic models available today have no real-time functionality and are usually summarized estimates. This is not to suggest that ALP is an optimization tool. ALP achieves a best feasible solution by managing penalty constraints and then continually computing answers closer to absolute optimal (ALP Overview, 1997:n. pag). Hard constraints and task precedence rules are used sparingly to avoid mitigating a feasible solution that is based on penalty tradeoffs. "For example, scheduling transport for M1 tanks on C-130's is physically impossible" (ALP Design, 1997:n. pag). Therefore, it must be entered into ALP as a hard constraint. In addition, scheduling any asset movement on a C-130 that has departed would violate precedence. Overall, the automated logistics planner captures asset and transportation requirement data from a highly distributed web of databases using a common language. ALP selects the best alternative from a set of feasible solutions even if some continuous penalty constraints are violated. Managers are notified of penalties associated with each COA. In this manner, the plan continually keeps the logistics support plan linked to operational need in a timely and more efficient manner.

The second grand challenge is real-time situation assessment. "This product will provide users at all echelons with the ability to assess the logistics situation by converting logistics data into information-rich visualizations that can be used to understand the current situation and project future states" (ALP Overview, 1997:n. pag). As depicted in

figure 7, underlying object-oriented technology is displayed in three-dimensional graphics. A user can obtain detailed information down to the fifth level by simply clicking on the object in question. In addition, a sliding time bar is available to select past and projected logistical states. The real-time situation assessment changes logistics data gathered across the full spectrum of the support pipeline into a user friendly inquiry model. Providing a continuous feedback mechanism to theater staffs and warfighting units is the only method of maintaining confidence among leadership and, thus, avoiding excessive inventories (just-in-case) from creeping into mission requirements.

Not only can a user determine where resources are located but also ascertain details on ownership as prioritization decisions are made in theater. As operations change, real-time logistic adjustments can be made based on operational need and follow-up replacement items immediately ordered. In this sense, many common use items can be requisitioned based upon forecasted theater need and diverted to actual requirements as late as possible during movement phases. This activity offsets lead times and overcomes incidents of misplaced or incorrectly delivered inventory. For example, assume a chemical attack occurs in one part of a contingency area. ALP automation evaluates intelligence and weather inputs and predicts requisitions of chemical defense gear. A decision-maker can take action on an ALP recommended COA or wait for additional information. As warfighters update specific needs, ALP cross-levels in theater supply, directs resupply from other theaters, formats resupply from the CONUS, and updates COAs without overreacting. ALP connectivity and advanced technologies allow rapid and efficient support even if it means the commodity must come from a manufacturer. ALP design identifies deviations to the logistics plan within fifteen

minutes of any data change and updates any related course of action within ten minutes (ALP Overview, 1997:n. pag). Commanders dealing with the chemical invasion can view the position of chemical gear and the predicted time of delivery in order to make tactical adjustments. Of course, time of delivery must meet one day CONUS and three day OCONUS objectives for most assets even in time of surge. As long as field units can depend on time-definite delivery of goods, forward-deployed units will have a reduced footprint (no extra supply). This decreases airlift volume requirements overall, especially during the initial build-up, while simultaneously increasing ground force mobility. Real-time logistics situation assessment tools are fundamental for any future automated system because it satisfies the customers "need to know" and effectively allows information to replace otherwise excessive requisitions and expensive safety stocks.

The third grand challenge is end-to-end movement control (Figure 8). There is no way to fulfill what is advertised in the real-time situation assessment without an automated interface with transportation. Similar to automated logistics planning and real-time situation assessment, the key to true end-to-end movement control is the extent to which transportation databases are linked or networked. The lift capabilities of each modal alternative combined with continuous automated scheduling form the basis of effective movement. Of course, inputs to ALP must include both organic and commercial transportation assets and the associated business rules used in the conduct of operations.

Along with the developing Joint Total Asset Visibility (JTAV) program, the Global Transportation Network (GTN) is an important example of the in-transit visibility that will be embedded in ALP. From this fully automated platform of data, ALP's end-

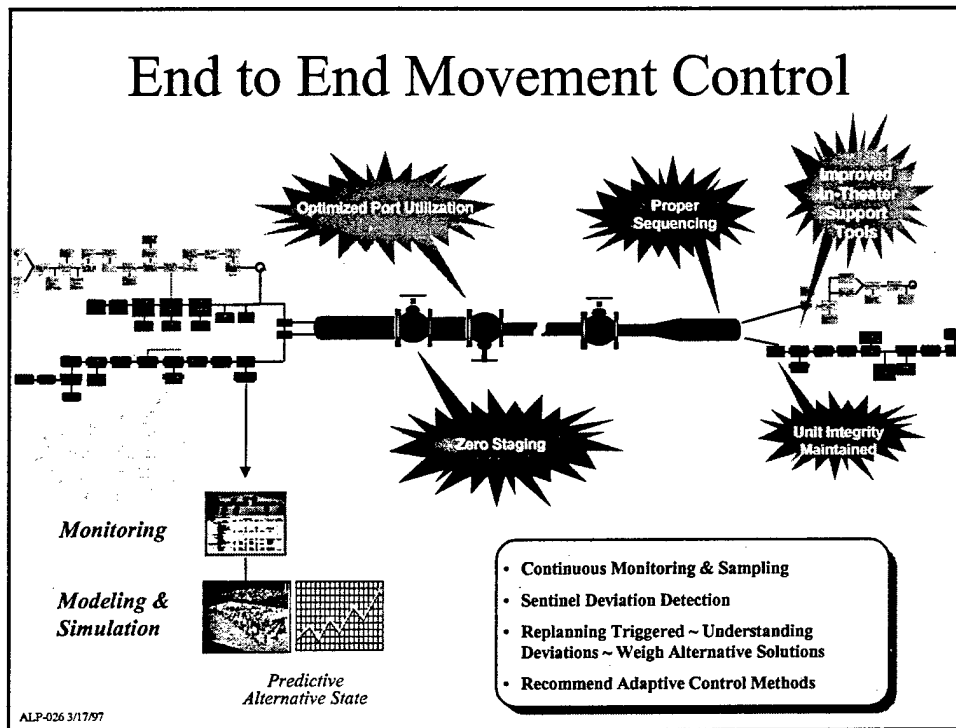

**Figure 8. ALP End-to-End Movement Control (ALP Overview, 1997)**

to-end movement can streamline flow and make recommendations to avoid bottlenecks (ALP Overview, 1997:n. pag). Mobilizing units are continually monitored for size and closure data in order to automate load planning and predict conflicts further down the pipeline. Complete automated in-transit visibility using bar code and RF tag technologies to feed the JTAV is well underway in DoD. This level of automation and consolidated information is necessary to achieve zero staging and optimized port utilization as well as proper sequencing to final destination. One lesson learned during Desert Shield and Desert Storm was that uncontrolled sequencing of units and supplies resulted in extensive support problems and wasteful uses of inventory and transportation. After examining Desert Storm logistics (Figure 9), DARPA concluded that one of the two most

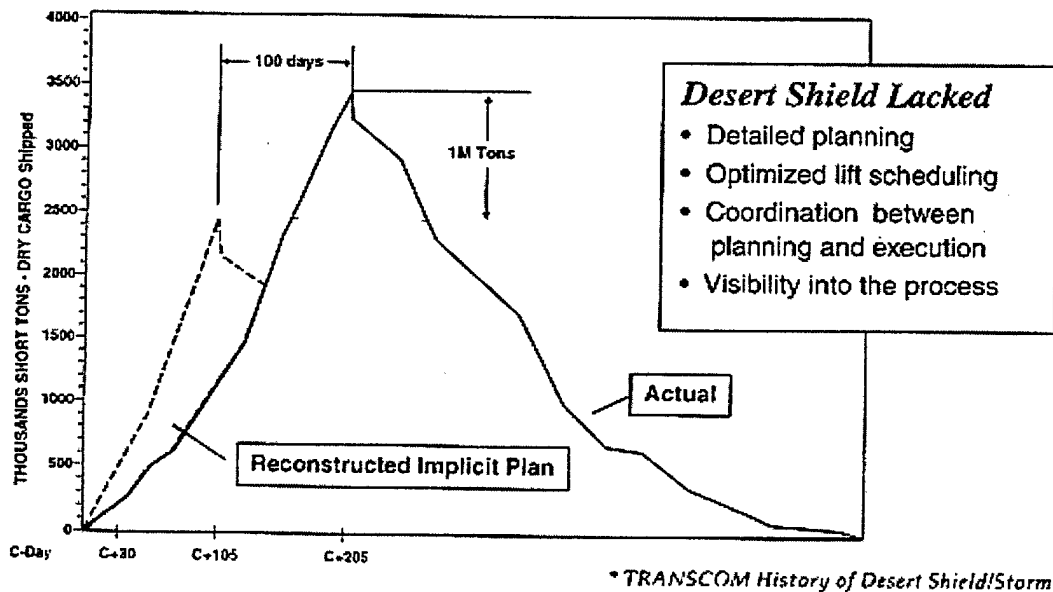

- Facts \***
- Improper sequencing caused 30-day slip.
  - In November 1990 actual unit footprints (ft<sup>2</sup>) doubled from gross plan.
  - At one point actual ammunition increased 1500% from gross plan.
  - Frenetic resupply environment for critical items.

**Figure 9. ALP Implicit Plan Versus Desert Shield Deployment (Lynn, 1996:17)**

noteworthy findings was that “overall sequencing of unit moves was not orchestrated” and this resulted in closure log jams and general confusion throughout the support structure (Lynn, 1997:15). Not only does end-to-end movement control have a significant impact on the just-in-case inventory issue, it supports effective tailored force operations by delivering the right asset to the right place at the right time.

ALP uses “plan sentinel” technology at key nodes or links in the logistics pipeline to trigger any deviation from original assumptions and expectations contained in the automated logistics plan (Lynn, 1996:17). Logistics managers are notified by ALP of the deviation, expected impact, and possible alternative solutions. “Plan sentinels will provide the necessary closed loop feedback to maintain control of the logistics system”

(Lynn, 1996:17) and overcome the widening gap (between operations and logistics) that has been experienced during previous campaigns.

End-to-end movement control takes ongoing efforts like GTN and JTAV to the next level and it is only one of four challenges set-forth by ALP managers. It serves as the vital bridge between the automated logistics planning function and the real-time situation assessment that provides confidence to operational commanders. The outcome of true movement control (time-definite delivery) is reduced inventory and associated storage, decreased demand on transportation in terms of metric tons, and less throughput infrastructure requirements.

End-to-end rapid supply describes the fourth grand challenge and is the technology insertion needed to leverage the advantages of DLA programs like Prime Vendor and Direct Vendor Delivery (Figure 10). “This product is devoted to the development of methods to establish interoperable connectivity and access between the DoD and commercial vendors, suppliers and manufacturers to increase material readiness, decrease cycle times for satisfying material requirements while reducing DoD inventory and overhead costs” (ALP Overview, 1997:n. pag). Automating the administrative process burden associated with requisition, transportation coordination, and throughput prioritization assists in reducing order and ship cycle times. DoD should only distribute inventory back to manufacturers and vendors when cycle times meet or exceed objectives. This depends on having a reliable logistics information system in place. Commercial product information is networked into ALP and suppliers have real-time visibility over actual usage at the point of consumption (ALP Overview, 1997:n. pag). Manufacturers can accurately implement process control over stock levels based on

automated anticipatory demand computations and, in turn, minimize the costs passed on to the customer.

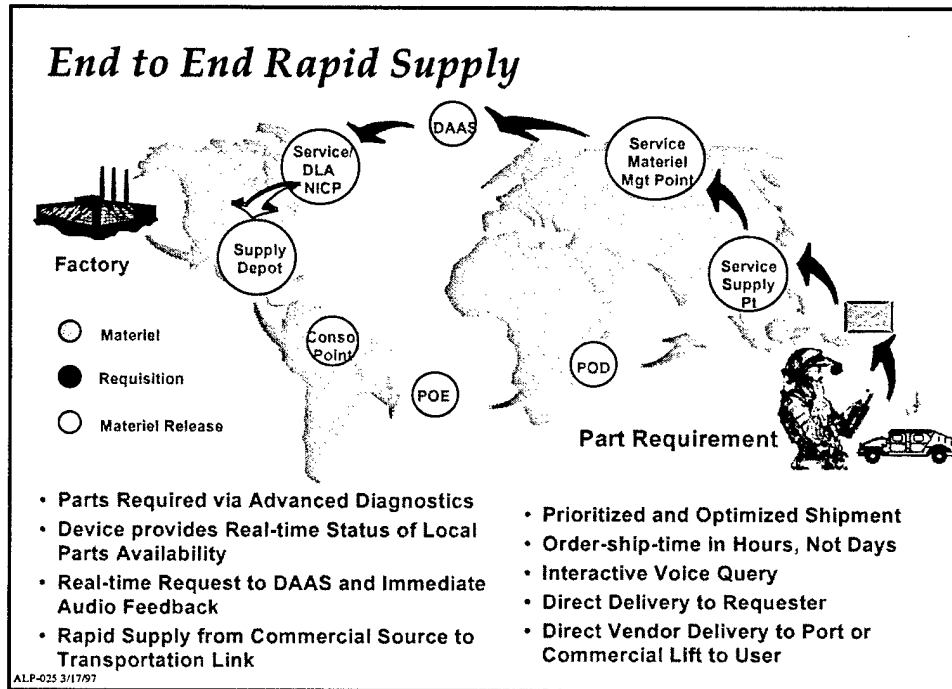

**Figure 10. ALP End-to-End Rapid Supply (ALP Overview, 1997)**

If a military surge requirement occurs, ALP can analyze system wide resource availability to meet increased consumption rates and communicate to manufactures the expected production requirements to sustain the force. Instead of traditional inventory protection between units in the field, an open exchange of assets can occur because users can rapidly know when their back-fill will occur. Elimination of redundant inventory in the field and a majority of expensive stockpiling at home for worst case scenarios are the power of an ALP system. Each specific asset will have to be inventoried according to its own expected demand and manufacturing lead-time. End-to-end rapid supply is the direct information leverage needed to achieve mandated inventory reduction goals and

make available funds for weapons modernization. As DoD outsources more logistics functions and responsibilities and DLA expands direct vendor delivery beyond medical supplies, the more critical rapid supply technology becomes.

In addition, the information that ALP captures provides monetary savings beyond those associated with simple inventory reduction. For example, the GAO reviewed inventory requirements for 22 F-100 engine consumable parts. Inaccuracies in the inventory requirements and related asset information caused the 1995 Air Force budget "to be understated by about \$2 million on some items and overstated by about \$10 million on others" (GAO-NSIAD-96-70, 1996:n. pag). When fully implemented, advanced logistics will assist inventory managers to compute requirements with accuracy that exceeds current heuristic approaches. ALP not only integrates operations and logistics continually but also the planning and execution of the supply chain.

The four grand challenges combine to capture comprehensive logistics information and convert it into a continually improving support solution. Operational adjustments by field commanders are made constantly to keep pace with fluid environments and the automatic logistics plan tool can modify the support course of action thoroughly within one hour. In order to keep operational footprints small and theater demand accurate, commanders must have complete confidence that consumable and repairable supplies are available in specified time-definite objectives. The real time logistics situation assessment establishes this confidence but it falls upon time-definite delivery to carry it forward. To ensure the right asset is delivered to the right soldier at the right time without just-in-case inventory means end-to-end movement control. The power of this information eliminates excessive waste involved in inventory staging and

improper sequencing. Finally, to enable the first three challenges and to push large DoD inventories back to the vendor requires end-to-end rapid supply. Establishing broad-based interoperable connectivity between commercial and DoD logistics managers is the very backbone of any serious endeavor to reduce government warehousing, inventory, and pipeline costs. Practical end-to-end rapid supply depends upon information technology that provides real-time visibility beyond movements, leverages the talent of commercial managers, and improves demand forecasting by using the continuous flow of information from operations. The technology insertions suggested by ALP is what focused logistics must have to achieve the efficiency necessary for operations with drastically reduced inventories.

### **The Technology That Makes It Happen**

ALP seeks to build a framework that does not ignore the contributions of any existing logistics management system. The costs and risks associated with developing a stand alone system and forcing units with unique requirements to use it are unnecessary given today's technological capabilities. "The ALP system design is being built and documented in the Unified Modeling Language (UML) using the Rational Rose tool. Using this tool, developers define objects and the interfaces among objects in the ALP system" (ALP Design, 1997:n. pag). Digital code is automatically generated to facilitate communications between unlike computers but legacy languages used for computations can remain in place. Rational Rose will use UML to generate Java and C++ object oriented communications and Windows NT will be the preferred (not required) operating system (ALP Design, 1997:n. pag). ALP design does not preclude low tech units from

being connected. Low bandwidth communications will allow inquiries from cellular phones and digital pagers (Carrico, 1997). Strategically, the effect of programs supporting focused logistics are greatly multiplied by tying individually developed logistics software packages together digitally through object oriented interfaces.

A major system integration effort is needed to implement this logistics concept. It is my sense that most of the enabling technologies required for development have been developed. Some of the information technologies that could immediately be brought to support this endeavor include bar code tagging technology, RF (radio frequency) smart response tags, relational data base systems, miniature global positioning system receivers and position reporting transmitters, satellite and fiber command and control communications links, and predictive campaign planning tools. (Kaminski, 1995:2)

The first step toward true logistics control is to capture logistics information quickly and accurately. The second step is to make it flow unobstructed between all agencies. Attempts at this second step over the past few years have fallen well short of expectations (Blazer, 1996) and therefore logistics streamlining teams are finding it difficult to keep pace with inventory reduction objectives. ALP brings to bear progressive technologies in a combined (DARPA, DLA, USTC) effort to flow logistics information in a useful manner.

Among these technologies are: the interconnection of models, simulations, and applications leading to real-time logistics control; scheduling and optimization; shared operations and logistics command and control schema; adaptive workflow; distributed multiechelon environments; interactive workgroups and decision support; object based information representation with drill down capability; plan element dependency analysis; plan sentinels based upon known or forecasted logistics capabilities that identify plan deficiencies; execution sentinels which detect when an action is not being executed according to plan; and automatic replanning options. (Advanced, 1998: n. pag)

Central to ALP design for the purposes of exploiting these technologies is its cluster orientation. The fundamental structure of a cluster begins with an object based information representation (Figure 11). An object is a software program represented by “attributes (data) and methods (operations performed on the object)” (ALP Design, 1997:n. pag). Method formats are used to transmit or receive requests but the internal workings of each system remains independent. This feature is known as encapsulation and allows units to develop and maintain the automated workings of their own systems without effecting ALP information gathering and analysis.

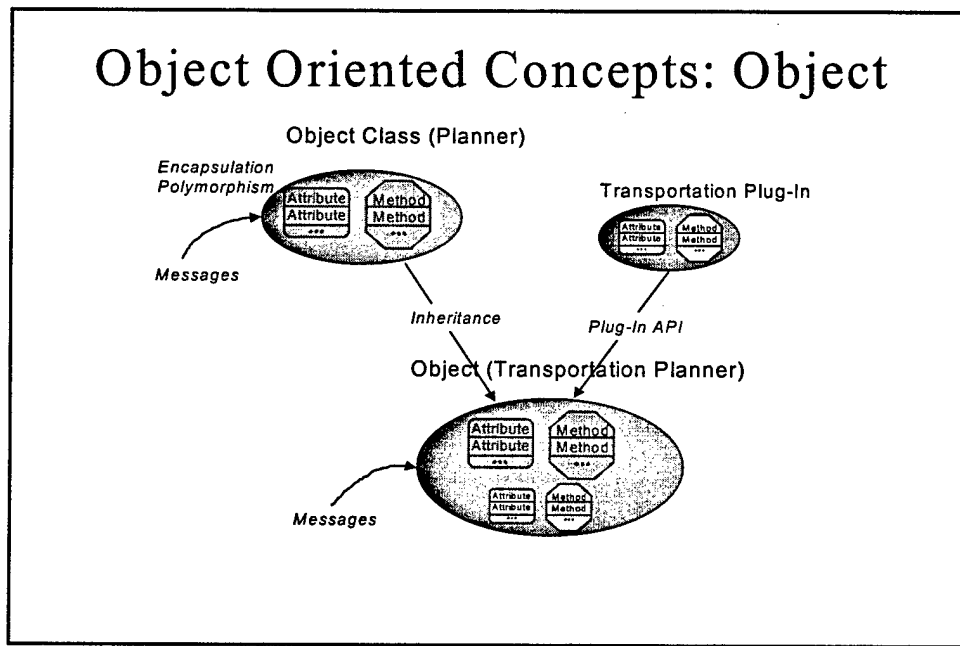

**Figure 11. Object Oriented Concepts (ALP Design, 1997)**

“Polymorphism means that the sender of a request does not need to know the specific type of object receiving the request” (ALP Design, 1997:n. pag). A unit simply states its requirements and selects the generalized method to communicate the needed support. Objects interface directly or combine into higher level objects until an overall system is working toward the best use of available assets across all functions. Higher

level objects may inherit analyzed and computed information (e.g., planning tools) and have an ALP facilitated plug-in capability for visibility over related assets (e.g., transportation). Plug-ins are functionally oriented at any of the echelon levels to support the task expander, allocator, or assessor as needed. The resultant transportation planner is networked with other defined object based systems such as inventory control points until a single logistics course of action and its limitations is generated. Object oriented design methodologies are a proven technology for building complex systems (ALP Design, 1997:n. pag) and are the basis for ALP's cluster strategy.

“The ALP cluster is the basic building block of the ALP system” (ALP Design, 1997:n. pag) and consists of both active and passive components (Figure 12 and 13). A cluster may represent one unit or a cross section of organizations unified by a mission. The task expander, allocator, and assessor are the active parts that are continuously revising the logistics plan to support operational changes within the boundaries of the data contained in the cluster's passive components.

From this starting point, ALP managers and engineers can replicate the cluster to represent all DoD units and its commercial partners until a society of clusters is formed. “Because of the distributed nature of the ALP cluster society – a society built of simple (generic) elements – military and commercial data sources can be integrated within a single logistics system in a consistent and scalable fashion. To this end, use of an Information Systems Office (ISO) compliant development environment is planned...and user access will be web-based” (ALP Design, 1997:n. pag). Externally generated directives are combined with internal cluster based directives to communicate the parameters of the logistics task at hand. “Clusters interact through messages called

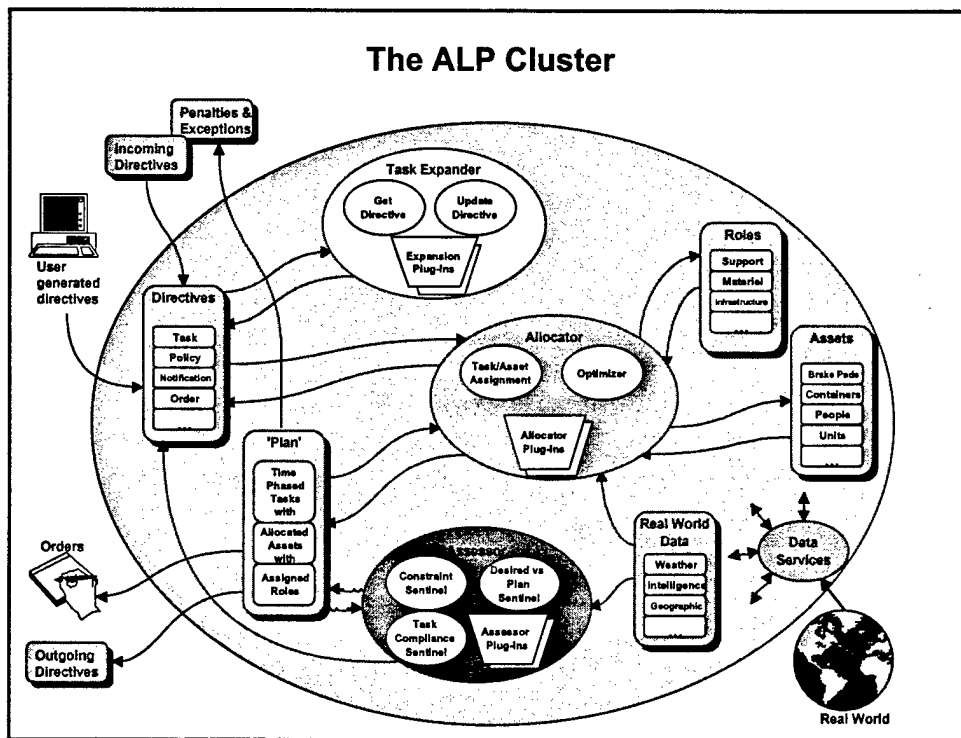

Figure 12. The ALP Cluster (ALP Design, 1997)

directives. These directives communicate requirements or tasks to other clusters and provide feedback as to the progress and cost (penalty) of satisfying these requests” (ALP Design, 1997:n. pag). These directives will usually come from a J3 component and be expanded into specific elements for subsequent allocation. “The allocator continuously processes (allocates) all the expanded tasks and populates the LogPlan with the results of the allocation” (ALP Design, 1997:n. pag). Assets are assigned to tasks or the burden is shared through directives to other clusters until a continually updating feasible solution is identified. Through the application of plan, constraint, and compliance sentinels, “the assessor continually monitors the dynamic LogPlan and the associated penalties of each scheduled event” (ALP Design, 1997:n. pag). Penalties are measured against

# ALP Cluster Elements

## Active

- Task Expander
  - implied and support task generator
- Allocator
  - demand allocation
  - resource scheduling
  - asset assignment
- Assessor
  - exception generation
  - planning factor sentinel
  - task compliance sentinel

## Passive

- Directives
  - task container
  - policy container
- Assets & Roles
  - current & planned states
  - scheduled availability
- Dynamic LogPlan
  - task-action pairs
  - task sequencing
- Real World Data
  - weather
  - intel

Figure 13. ALP Cluster Elements (ALP Design, 1997)

predetermined thresholds so that violations can be made known to ALP managers. Automated replanning over the complete spectrum of logistic support to minimize penalties is the strength of ALP. Integrating simple object based formats in a building block fashion (clusters) is extremely powerful because users retain the majority of software design freedom and benefit from the decision making and plug-in features of ALP. “Large-scale logistics solutions emerge from the interactions of a society of simpler, smaller functional pieces. Clusters can be added and removed from the society to match evolving real-world logistics demands” (ALP Design, 1997:n. pag). In essence,

the four grand challenges of ALP are resolved through this distributed network of flowing information.

Although all this seems like “techno-talk”, the bottom-line is that object oriented communication connects legacy logistics and operations computer systems. Basic ALP cluster technology has been demonstrated and can rapidly resolve logistic problems where other information systems have failed. ALP’s approach is simple and effective and the likelihood of putting the system in-place across DoD should be considered high. The successful completion of the first phase of ALP development validates its potential. Illustrating ALP’s automated information flow is rather straightforward when reviewing the program’s baseline “use cases” (Figure 14). Use cases are logistic scenarios that exercise ALP through development and maturation. For example, the transportation support for the 3<sup>rd</sup> Infantry Division (ID) from a port of debarkation to a newly assigned tactical assembly area (TAA) may require hundreds of man hours just to prioritize, coordinate and schedule the movement. Still, vital transportation and inventories are often misused. In today’s environment, staging days at a port of debarkation (POD) while “things” are worked out would not be unusual. Using a common interface to communicate between unlike logistic data sources, ALP plans the movement of the 3<sup>rd</sup> ID in less than an hour (Figure 15). First, ALP is constantly receiving input on the 3<sup>rd</sup> ID’s strategic leg (CONUS to POD) from GTN. ALP also recognizes that all portions of the 3<sup>rd</sup> are needed at the TAA because CENTCOM J3 (Central Command operations staff) and the service components have built the “above the line” combat force requirements into the automatic logistics planning function. From this point, ALP determines the “below the line” support forces to accomplish the movement above the self contained

capability of the 3<sup>rd</sup> ID. For example, the 3<sup>rd</sup> ID needs heavy equipment transportation (HET) support for tanks and artillery. The HET companies assigned to the theater are rescheduled based upon CENTCOM priorities. ALP expands the task “move the 3<sup>rd</sup> to the TAA” into a time-phased schedule that includes loading, transport, unloading, and return of support units. In addition, the use of the HET generates additional implied tasks such as fuel servicing, driver limitations, and equipment reliability. CENTCOM policy directives are combined with 3<sup>rd</sup> ID mobility directives as ALP begins allocating resources and evaluates alternative feasible solutions. The ALP assessor interfaces with real-world information sources (weather, threat analysis) and uses sentinel penalty measurements (feasible solution versus updated logistics plan) to recommend a course of action. If CENTCOM decision makers accept the recommendations with the highlighted impacts to the remainder of theater operations, then updated unit schedules are sent forward. The combat unit cluster (3<sup>rd</sup> ID) is matched with service provider clusters including the theater HET companies before the 3<sup>rd</sup> hits the ground at the POD. Even if the HET is not in theater, relative tasks will be sequenced accordingly and formulated into a new comprehensive logistics plan. Of course, the information flow is much more intense than this example illustrates but the message is clear. Advanced automation that continuously links operational priorities with support functions multiplies combat effectiveness and allows deployed forces to be efficiently tailored.

While the 3<sup>rd</sup> ID example categorized as a deployment use case, it emphasizes the distinct advantage of rapidly building a properly sequenced logistics plan to respond to unforeseen circumstances. The same concept is applicable in terms of inventory

# Design Use Cases

Missions	Tasks	Deploy		Sustainment	
	Environment	Home	Theater	Home	Theater
Peace		A. NTC training: [Infantry BDE to NTC & return]		B. Dual Optimization: [Allocation of Supplies & Transportation]	
Operational Requirements Shift			C. Reconstitute & Redeploy 82 <sup>nd</sup> Airborne		D. New Threat [Chem Suits Critical]
Crisis		F. 3 <sup>rd</sup> ID Predeployment [Demand Surge]	H. Transportation for 3 <sup>rd</sup> ID in theater [POD to TAA]	I. Disaster relief [Hurricane]	J. Support [Fuel]
		G. II MEF Falls in on MPSRON #2	E. Ground Force Support [Task Expansion]		

Figure 14. Design Use Cases (ALP Design, 1997)

## Transportation for 3<sup>rd</sup> ID from POD to TAA

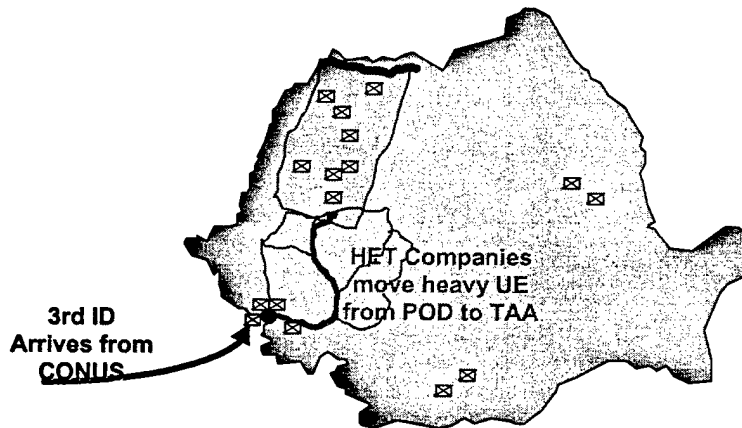

Figure 15. Transportation for the 3<sup>rd</sup> ID from POD to TAA (ALP Design, 1997)

management and sustainment. Determining the least costly method of requisitioning and transporting a demanded supply on time and in proper sequence can all be accomplished using ALP. The advantage of consolidating all this information in one computer system is that overall costs are minimized rather than purchase cost or transportation cost as an individual component of logistics. ALP's Dual Optimization use case deconflicts all these traditional logistics tradeoffs to optimize inventory decisions and operate in a just-in-time format. This type of planning and execution is vital in meeting future inventory reduction mandates.

The technology insertion that ALP represents has little to do with modifying legacy logistics systems and everything to do with networking them using common object based computer languages. Building the network from the unit level up and in the cluster format allows command directives to reach the working units as soon as a course of action is selected. "Optimization of the logistics system is based on an aggregation of continuous real-time, detailed assessments of exceptions and penalties provided by each cluster" (ALP Design, 1997:n. pag). Real-time information and anticipatory logistics replaces slow coordination/scheduling processes and just-in-case stockpiling. While ALP moves forward in establishing this desperately needed logistics control, transportation managers must consider how current capabilities support the strategy. In particular, DoD airlift must adjust its business practices to support one-day CONUS and three-day OCONUS movement objectives that will assist in reducing inventory. The confidence of the warfighting commanders in advanced logistical practices hinges on time-definite transportation.

## V. Time Definite Transportation

### **General**

Keeping deployed forces and their support to a minimum in a theater of operations not only requires automated logistics information but fast and frequent transportation of consumables and reparable. Large scale staging at bases close to the area of responsibility and significant regional prepositioned assets tend to defeat the leverage of an ALP system. Suboptimization occurs when any portion of the logistics pipeline is lengthened and additional inventory is required to ensure customer satisfaction. This phenomenon can become insidious in the transportation segment when excessive transshipment times occur in an effort to gain efficiencies through consolidation of materials. “When an asset is moved fast, it experiences little or no queue time. It doesn’t wait for a cart or pallet or truck or whatever to fill up before it’s moved to the next step in the process – as the engineers say, stuff is moved in ‘transfer batch’ sizes of one. This is the most important piece of fast transportation, however, fast also means move the asset in the quickest way practical. For most items this means next day air, or dedicated truck” (Moore, 1997). Moving items the quickest way practical includes node reduction as well. Transshipment of goods from one airlift mode to another can drive increased inventory requirements and undermine the one-day/three-day delivery response goals. In summary, small shipments (batch sizes) on fast vehicles (air transportation) with little to no transshipment time is what advanced logistics information aims toward. When considering the future of logistics information technology, the rapid transportation system will need to be more flexible in direct delivery of small shipments.

## **Organic**

Direct airlift shipments in an era of advanced logistical control highlights some important issues for force planners today. The first consideration is the use of forecasted organic airlift aircraft. Even aggressive acquisition reform will not reduce military aircraft development and production timelines below ten years. Therefore, the planned force structure should be expected unless additional funding becomes available for additional buys of existing planes or new commercial-off-the-shelf airlift aircraft. The savings generated by information substitution in logistics management will likely be spread among many modernization efforts and not solely dedicated toward the transportation slice of overall logistic disciplines. In ten years or less the DoD will have limited organic aircraft to perform strategic lift (C-5, C-17). While ALP reduces footprints and, thus, overall cargo throughput requirements, it will demand rapid and frequent movement. ALP solutions may not be able to efficiently utilize aircraft designed for oversized cargo and heavy payloads because penalties for late delivery should be larger than those for underutilized aircraft cargo space. If the payloads in Desert Storm were below planning factors (Figure 16) then efficiency expectations should not be high in a future ALP connected operation.

Although the direct delivery capability design of the C-17 saves valuable hours in transshipment because it by-passes intermediate staging points, the number required to fulfill fast intertheater and unique intratheater airlift may be excessive. "In-theater operation of this aircraft is a preferred role, especially if priority is placed on the

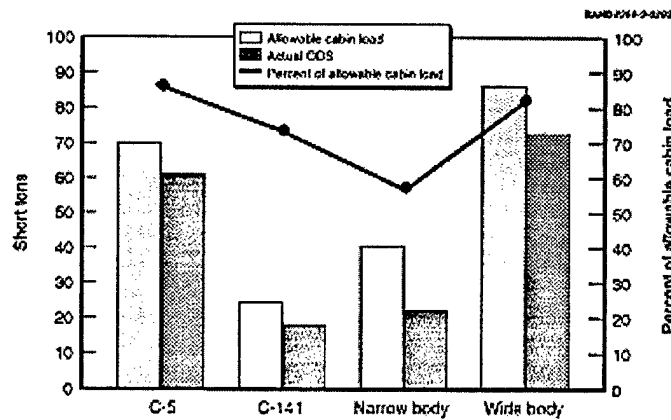

Payload: Actual Versus Planning Factors

**Figure 16. Desert Storm Airlift Planning Factors Versus Actual Payloads (Lund, 1993:21)**

in-theater movement requirements” (Killingsworth, 1997:xi). These issues have not gone completely unrecognized. For example, the initiation of Air Mobility Express (AMX) is a first step in developing a channel airlift format that integrates commercial and organic aircraft to move sustainment items on time (Wilson, 1998). AMX plans for one departure and arrival per day (surge to two) from a commercial aerial port and extracts the aircraft from the theater CINC’s allocations (Wilson, 1998). Unfortunately, AMX will only be activated for contingencies and is dependent on real-time information to meet its time-definite delivery objectives. Another example is the Air Force Door-to-Door Distribution (D3) program that uses commercial express capabilities to accomplish time-definite delivery. However, “D3 can further increase shipment velocity if cargo is moved directly from the point of issue to point of receipt” (LLMP, 1995:61). ALP can be expected to demand many more daily missions with lighter loads that are time constrained. Organic

air transportation may have to employ smaller aircraft (possibly C-130s that are usually committed to theater operations) that do not delay inventory movement to a user or aerial port of embarkation. In the CONUS alone, moving assets direct from widely separated vendors to user or transshipment destinations will probably be required to meet one day delivery objectives and three day movements overseas. This also means more assets moving in smaller amounts at high speeds. The organic fleet that had efficiency problems in Desert Storm may be worse off in future operations. Commercial airlift limitations in an advanced logistics era are just as pronounced as in the organic fleet.

#### **CRAF**

The Civil Reserve Airlift Fleet (CRAF) is activated in a series of three stages. "Stage I is composed of long range assets and when activated, carriers are given a maximum of 24 hours after mission assignment to respond to the initial mission onload location" (United, 1997b:2). Stages II and III consist of varying levels of long range, medium range, and aeromedical support aircraft. Although the emphasis up front is for wide body international capability to move a majority of passengers and a significant level of cargo, this presents two problems in an advanced logistics setting. First, CRAF international assets generally require long runways and are not prepared to operate in hostile theaters of operation. Financially insuring these expensive aircraft in a contingency area is still an unresolved issue and unionized aircrews are not required to participate. What this probably means is unavoidable transshipment times at aerial PODs. If trucks and rail cannot deliver goods to a final destination within the three-day time-definite window, then organic aircraft (C-130, C-17) will have to be committed.

ALP will sequence and schedule material movement so that staging is minimized and aircraft are used as effectively as possible but the need for in-theater CINC aircraft will eventually conflict with AMX strategy (aircraft used count against CINC).

The second problem for fast transportation is closely connected to the first. If stage I (large wide body aircraft) is activated and DoD time-definite demand has increased, CRAF carriers may be inefficiently used (due to small cargo loads) and also find it difficult to meet the needs of their commercial customers. In addition, the number of vendors (prime vendor and direct vendor delivery) requiring fast transportation to support US forces will be extensive. In short, CONUS based delivery times to APOEs may have to be reduced below twenty-four hours in order to achieve the three-day to destination objective. Further integrating organic airlift into the commercial flow or allowing increased landing rights for commercial aircraft at APOEs may improve the process. Overall, advanced logistics will impact the defense transportation system (DTS) business practices.

### **Other Issues**

The issues facing time-definite transportation in an ALP environment cannot be dismissed. Efficient use of limited organic aircraft and restricted CRAF capabilities only scratch the surface of factors that DTS managers must review. For example, Title 49 USC section 40118 requires DoD to use US flag air carriers and section 41106 mandates that DoD air transportation contracts over 30 days be awarded to a CRAF carrier (United, 1997b:6). The Express Delivery Reinvention Laboratory is one example of a defense organization that is beginning to address these types of issues with sponsored studies

such as the AMX sizing follow-up (Express, 1998:n. pag). DTS should not expect commuter airlines to look the same in a few years either. Congress only extended the subsidy payments to the commuter air program called Essential Air Service through 1998 (Wood, 1996:220). The point here is that the air transportation business is restricted in some respects and evolving in others. The direction it is taking may not be suitable for superior operations in an information rich future. While some agencies study the specific air mobility problems, the needed lead time to adjust air transportation in light of advanced logistics may be lost.

Ground transportation has farther to go also. The Military Traffic Management Command's (MTMC) new contract to support the Army's largest base recipient of materials (Ft Hood) allows in-transit delivery times up to five days (Schott, 1997:15). In essence, the DTS will have to evolve under many constraints and ensure a time-definite capability if ALP managers are to meet the governments inventory reduction goals. After all, "this reduction in transportation time is the main thrust that reduces asset requirements in the overall system" (Hill, 1994:5). "The cost of a transportation service failure to deliver a critical item when and where required may be significant in terms of weapon system downtime, customer dissatisfaction, and unnecessary expenditures for stock and storage" (LLMP, 1995:35). ALP strategy is only effective if commanders can expect consistent time-definite deliveries of commodities and reparable.

## VI. Timeline Convergence

### **General**

There exists a large array of revolutionary logistics programs in DoD that need to be interlocked through information exchange. ALP is constructed in three phases and is programmed to deliver a real-time focused logistics information system to support all services, agencies, and CINCs by 2002 (Williams, 1997). A small society of clusters has been built for testing and the ability to visualize their interaction through directives has already been demonstrated (Carrico, 1997). Figure 17 depicts the ALP system technology roadmap that ultimately delivers the automated logistics information capability that so many other programs will depend upon for efficient operations. Of course, the entire ALP concept capitalizes on the hard work of many other efforts. The timely deployment of GTN is a good example. "While GTN will be fully deployed in 1999, it's operational today and enables USTRANSCOM to screen transportation requirements and provide all DoD with the intransit visibility for ongoing movements" (United, 1997a:15). Of course, the GTN effort has its own set of problems. Business processes always require review and modification when new technology is adopted. In other words, GTN managers must support methods of reducing user-input errors while ensuring codependent systems are fielded. For example "the transportation coordinators automated information for movements system (TC-AIMS) II is the system that provides the information to GTN on deploying and redeploying units. TC-AIMS II, with the

# Capabilities Roadmap

	FY 97	FY 98	FY 99	FY 00 / 01
<b>Cluster/ Architecture</b>	<ul style="list-style-type: none"> <li>• Small Society (12 clusters)</li> <li>• Prototype Plug-in</li> </ul>	<ul style="list-style-type: none"> <li>• Full Cluster Implementation</li> <li>• Penalty-based allocation</li> </ul>	<ul style="list-style-type: none"> <li>• Seamless transition from projection to execution</li> <li>• Multiple simultaneous LogPlans</li> </ul>	<ul style="list-style-type: none"> <li>• Network recovery and synchronization</li> <li>• Dynamic Society management and deployment</li> </ul>
<b>Auto Log Plan</b>	<ul style="list-style-type: none"> <li>• Simple Data Mediation</li> <li>• Initial Plan Visualization</li> </ul>	<ul style="list-style-type: none"> <li>• Initial Auto LogPlan Generation</li> <li>• Simple Plan Sentinels</li> </ul>	<ul style="list-style-type: none"> <li>• Auto Log Plan in 3 hours</li> <li>• Integrated Ops/Log Warplan Object</li> </ul>	<ul style="list-style-type: none"> <li>• Advanced Log Plan Visualization &amp; Drilldown</li> <li>• Advanced Plan Sentinels</li> </ul>
<b>End-to-End Movement Control</b>	<ul style="list-style-type: none"> <li>• Coarse grained scheduling</li> <li>• Weigh-in-Motion</li> </ul>	<ul style="list-style-type: none"> <li>• Automated Mode Selection</li> <li>• Optimized Lift Schedules</li> </ul>	<ul style="list-style-type: none"> <li>• Movement projection and visualization</li> <li>• In theater scheduling</li> </ul>	<ul style="list-style-type: none"> <li>• Continuous vehicle tracking</li> <li>• Installation to TAA scheduling</li> </ul>
<b>Rapid Supply</b>	<ul style="list-style-type: none"> <li>• Web based parts ordering</li> <li>• Voice recognition status reporting</li> </ul>	<ul style="list-style-type: none"> <li>• Automated supplier selection</li> <li>• Visibility of commercial inventory</li> </ul>	<ul style="list-style-type: none"> <li>• Supply policy support</li> <li>• Automated critical item planning</li> </ul>	<ul style="list-style-type: none"> <li>• Integrated supply and trans asset optimization</li> <li>• Forecasted demand scheduling</li> </ul>
<b>Execution Monitoring</b>	<ul style="list-style-type: none"> <li>• Geographic display of forces</li> <li>• Monitoring critical item list</li> </ul>	<ul style="list-style-type: none"> <li>• Visually monitor log plan execution</li> <li>• View planned resource allocations</li> </ul>	<ul style="list-style-type: none"> <li>• Project and detect plan failure</li> <li>• Collaboration for users to manage exceptions</li> </ul>	<ul style="list-style-type: none"> <li>• Detailed LSA for selected weapon systems</li> <li>• Weather impact on plan projections</li> </ul>

Figure 17. ALP Roadmap (ALP Overview, 1997)

Army as the executive agent is not yet fielded and needs continued funding” (United, 1997a:18). In addition to in-transit visibility from GTN, the JTAV program is on an important timeline similar to ALP. “According to DoD’s current plan, the total asset visibility initiative will not be completely implemented until 2001” (GAO-HR-97-5, 1997:n. pag). One final example that is ahead of many other logistics automation efforts but is vital as part of the overarching ALP system is DSS. As mentioned in section III, the DSS will be deployed in 1998. Successful reductions in DOD inventory and footprints are reliant on the development and eventual merger of these programs. While many related defense programs have not been included in this study, the principle is the

same. In less than five years, redundant logistics automation should be eliminated and those remaining captured under one integrated network.

### **DLA at Work**

Driving this technology insertion timeline is highlighted by infrastructure adjustments at DLA. For example, the consolidation of inventory control points (ICPs) offers such significant savings that it will be pushed forward without comprehensive impact studies. The efforts “projected cost savings of \$2.2 billion to \$3.8 billion cover a 13-year period, fiscal years 1998 – 2010” (GAO-NSIAD-97-157, 1997:n. pag). What this means is additional pressure on DLA and the services to place more products into direct vendor delivery format, thus, requiring exceptional automation of logistics information to manage the entire logistics support mechanism. The current 16 ICPs will be reduced to 11 by 2003 (GAO-NSIAD-97-157, 1997:n. pag). General inventory and storage space reduction policies are a fundamental justification for research and development of automated logistics control and are worth reemphasizing. DoD’s strategic plan is designed to cut “redundant or secondary inventories from \$70 billion to \$53 billion or less by October 2001, or 24 percent, and to shrink the amount of occupied storage space from 631 million cubic feet to 375 million cubic feet or less” (Traffic, 1997:32). Other sources see inventory funding going even lower. DoD reduced inventory by 37 percent between 1989 and 1996 (\$107 to \$67 billion) and projects “a further reduction to \$48 billion” (Emahiser, 1998:5). Many of DLA’s strategic objectives respond to these charters and are directly related to ALP operational capability. For example, DLA intends to deploy web technologies and interfaces on systems and

databases by 2002 and reduce overall infrastructure (square footage) by 40% from a FY1996 baseline by the end of FY2005 (Our, 1998:n. pag). DLA's Direct Vendor Delivery program has already had great success with many medical commodities and the Virtual Prime Vendor pilot site is established at Robins Air Force Base (Emahiser, 1998:4). In short, the outsourcing, downsizing, and reengineering trends at DLA require a powerful logistics information tool if operational units are to stand ready and have reliable support when deployed.

## VII. Conclusion and Recommendations

### **Conclusion**

The systematic approach to logistics improvement relies on a single core principle. No matter how far one discipline of logistics is improved, the system is only as good as the weakest aspect. As new logistics business practices are put on DoD's fast track, air transportation must anticipate the associated influence this has on operations. A fully automated logistics information system that overcomes traditional interoperability problems will set the tone for future operations support. ALP is an aggressive measure that has the potential to finally join fluid operations with critical logistical support. Real-time information can shorten the logistics pipeline and reduce expensive inventories. However, the full benefit of ALP will only be realized if fast transportation is correctly designed to operate in a just-in-time network. For example, if aircraft availability is very sensitive to order and ship times of repairables (Gaddis, 1995:91), then inventory reduced repairable items must move quickly and accurately to keep aircraft flying. ALP enables this to occur.

Of course, transportation planners must also realize that large assets are not normally considered express cargo and constitute nearly 50 percent of DoD volume (Pyles, 1998b). Therefore, a balance must be struck between small, fast moving transportation and large aircraft capable of moving oversized or outsized cargo. Ensuring the airlift infrastructure is prepared to meet its halting phase obligations and then deliver critical supplies and general commodities in an efficient and time-definite manner is vital in an era of advanced logistics and fiscal constraint. As is correctly pointed out in logistics research for the Air Force 2025 project, "transportation will always be a critical

constraint” (Edgell, 1996:26). The DTS 2010 strategy must be closely linked to the thrust of those programs supporting focused logistics and advanced information flow. Airlift strategy will likely be quite different when a real-time information logistics system is in place.

Currently, DoD uses several analytical and heuristic models to plan mobility operations that support various scenarios around the world. None of these models has a complete end-to-end movement planning capability in and of itself and very few are of any use during an actual contingency execution. The ineffectiveness of the TPFDD and the Joint Operations Planning and Execution System (JOPES) were highlighted early in Operation Desert Storm (Lund, 1993:24). In addition, well intended efforts to rectify this shortcoming in mobility operations and logistics support has experienced complex integration issues resulting in slow progress. The DARPA led advanced logistics program could suffer the same fate except for four main points. First, ALP is fundamentally based upon proven object-oriented technologies that can establish interoperability between legacy systems. Second, ALP is cosponsored by DLA and USMC and is fully funded through its final phase. Third, unlike the CIM effort (GAO-HR-97-5, 1997:n. pag), ALP is testing its system thoroughly during each phase. Fourth, the continuing rapid reduction in DoD held inventory necessitates the substitution of logistics information now more than ever before. Future military operations will mandate early planning and immediate and accurate decisions. “As battlefield commanders become confident that they know the range of their material requirements, the location of the material that they need at all times, and the amount of time it will take to acquire it, the need to own and hold stock will be dramatically reduced” (Muczyk, 1997:5). This

can be accomplished using the cluster strategy, drill down capability, and visual rich display of ALP.

## **Recommendations**

Effective and efficient support for tomorrow's warfighter is not a simple matter of replacing large inventories with information technology. Human input error, parochial barriers, and broken process control has long been the nemesis of a smooth flowing logistics pipeline. Nonetheless, current object oriented technology combined with the exponential rate of overall technological advancement can create a new era of defense logistics methods that counter many traditional problems. In addition, fast transportation will continue to increase its market share in asset movement as system wide accounting methods are refined. Therefore, DoD should initiate a feasibility study to specifically examine air operations in the forecasted advanced logistics environment. For example, an evaluation of those aircraft in stage one of the CRAF may reveal needed adjustments. While AMX is moving war critical assets direct from a commercial hub to an APOD, CONUS range aircraft activated in stage one could deliver assets direct from commercial locations to APOEs on a more frequent basis. Federal Express has just begun to acquire medium range cargo aircraft (Phillips E., 1996:34) that could reduce CONUS transshipment delays during contingencies. Keeping the transportation segment of logistics on pace and properly aligned with the enabling power of information is a key challenge for mobility leaders.

DoD has made impressive reductions in owned inventory since Operation Desert Storm. The consolidation of a large portion of goods from the services to DLA has

eliminated redundancy and permitted single agency process control. DoD should require each service to develop ALP-dependent timelines for the transfer of all remaining inventories to DLA. DLA will assume the responsibility of ensuring that operations, support, and maintenance commanders have complete visibility over mission essential parts through ALP. The federal budget and deficit goals, weapons modernization costs, and defense readiness mandate that every benefit of advanced logistics information is leveraged. DLA must carefully expand its leading programs (virtual prime vendor, direct vendor delivery, premium service) so that obtaining supplies at the unit level is a user friendly, information rich process. In this respect, each armed service and their pertinent units should understand the ALP concept and timeline. Automated support systems can continue to be developed and legacy systems maintained because of the interface design of ALP. In turn, if any unit in DoD views ALP as a solution that replaces similar ongoing programs then cost savings may be realized near term.

Finally, it is critical to keep ALP on track and fully funded through 2002. Even if the program should somehow fail to deliver the advertised connectivity, the current progress and high probability of successes ahead (due to existent technology usage) make the endeavor recommendable. Further, a highly automated logistics system specifically designed for the unique needs of military operations is a logical requirement given the DoD inventory reduction objectives. ALP is an aggressive strategy with realistic technological expectations. Where possible, other logistics information programs that will ultimately feed the network should favor timelines that coincide with ALP. This would add to what seems to be a natural convergence of various logistics efforts out in the four to five year window.

## Bibliography

- Advanced Logistic Program (ALP) Joint Logistics Advanced Concept Technology Demonstration (JL ACTD). Excerpt from unpublished Board Agency Announcement (BAA) 97-32, n. pag. WWWeb, <http://www.darpa.mil/baa/BAA97-32.txt>, 17 April 1998.
- AFDD-1, Department of the Air Force. Air Force Basic Doctrine. Air Force Doctrine Document 1 (AFDD-1). Washington: HQ USAF September 1997.
- Air Mobility Command Logistics Directorate. Excerpt from untitled, unpublished briefing slides received by e-mail, n.pag. 4 June 1998.
- Allen, W. Bruce. "The Logistics Revolution and Transportation," Annals of American Academy of Political & Social Science: 106-116 (September 1997).
- ALP Overview briefing. Extracted from unpublished Advanced Logistics Program (ALP) briefing slides with text, n.pag. WWWeb, <https://www.iso.darpa.mil>. 17 April 1997.
- ALP Design briefing. Extracted from unpublished Advanced Logistics Program (ALP) briefing slides with text, n.pag. WWWeb, <https://www.iso.darpa.mil>. 17 April 1997.
- Blazer, Doug. "Future Vision for the Air Force Logistics System," Logistics Management Institute. McLean VA. (LMI-IR503MRI) July 1996.
- Brunkow, Dr. Robert D. "Lean Logistics," 1996 Air Mobility Command History, 1: 186-188. 1 January 1996 to 31 December 1996.
- Carrico, Todd M. Advanced Logistics Program Manager. "Advanced Logistics Program." Briefing to Gen Kross, USTC. DARPA, Washington DC, 5 December 1997.
- Cusick, Lt Gen John J. and Lt Col Donald C. Pipp. "In Search of Focused Logistics," Air Force Journal of Logistics: 26-28 (Winter 1997).
- Defense Advanced Research Projects Agency and the Defense Logistics Agency. Advanced Logistics Program. Agency Pamphlet. Washington: Defense Advanced Research Projects Agency, 1998.
- "Distribution Support," Extracted from unpublished Defense Logistics Agency document, n.pag. WWWeb, <http://www.dla.mil/public%5Finfo/distrib.htm>. 17 April 1997.

DLA Re-engineering Government. Defense Logistics Agency Video Production.  
Ft Belvoir VA. 11 March 1997.

Drucker, Ronald W. Chairman, NDTA Technology Committee. "Role of Information Technology in Transportation and Asset Management," Defense Transportation Journal: 30-31 (November/December 1994).

Edgell, Jaydee, CDR S.K. Spangler, Maj G.F. Dragoo, and Maj L.W. Jackson. Logistics in 2025: Consider It Done. A Research Paper Presented to Air Force 2025. Washington: HQ USAF, August 1996. Full document found at WWWeb, <http://tuvok.au.af.mil/au/database/research/ay1996/acsc/96-025af.htm>

Emahiser, James B. "Inventory Management Crucial to Mission Success," Defense Issues 12: Number 23, 20 March 1997.

Express Delivery Reinvention Laboratory (EDRL) Studies. Excerpts from unpublished document, n.pag. WWWeb, <http://www.il.hq.af.mil/ilt>. 21 January 1998.

Fogleman, Gen Ronald R. "Vision 2010 defines Air Force future". Air Force Times, 9 September 1996:27.

Gaddis, Craig S. and David A. Haase. A Performance Analysis of the Air Force "War Time" Lean Logistics. MS Thesis, AFIT/GIM/LAL/95S-2. School of Logistics and Acquisition Management, Air Force Institute of Technology (AU), Wright-Patterson AFB OH, September 1995 (AD-A300450).

GAO-HR-97-5, General Accounting Office. Defense Inventory Management. Washington: GPO, 1997. As extracted from <http://www.access.gpo.gov>.

GAO-NSIAD-97-28, General Accounting Office. Logistics Planning: Opportunities for Enhancing DoD's Logistics Strategic Plan. Washington: GPO, 1996. As extracted from <http://www.access.gpo.gov>.

GAO-NSIAD-96-70, General Accounting Office. Defense Logistics: Requirement Determinations for Aviation Spare Parts Need to Be Improved. Washington: GPO, 1996. As extracted from <http://www.access.gpo.gov>.

GAO, NSIAD-97-157, General Accounting Office. Defense Infrastructure: Inventory Control Point Consolidation Savings Would Be Substantial. Washington: GPO, 1997. As extracted from <http://www.access.gpo.gov>.

"Global Engagement: A Vision for the 21<sup>st</sup> Century," USAF Core Competencies. Excerpt from government document, n.pag. WWWeb, <http://www.xp.hq.af.mil/xpx/21/core/agile.htm>. 31 March 1998.

- Hicks, Heston and Phil Nicolai. "An Interview With Colonel Guy R. Vanderman, Chief, Lean Logistics Program Management Office," Logistics for the 21<sup>st</sup> Century, A Special Report by the Supportability Investment Decision Analysis Center (SIDAC): 2-3. Wright-Patterson AFB OH (1996).
- Hill, Tracey L. and William N. Walker. An Analysis of the Effects of Lean Logistics on the Current Air Force Repairable Pipeline: A Simulation Study. MS Thesis, AFIT/GLM/LAL/94S-22. School of Logistics and Acquisition Management, Air Force Institute of Technology (AU), Wright-Patterson AFB OH, September 1994 (AD-A285298).
- Jamison, Lt Col James F. USTC-J5-SC, Scott AFB IL. Staff Summary Sheet. 17 October 1997.
- Kaminski, Paul G. Undersecretary of Defense for Acquisition and Technology. "Lean Logistics: Better, Faster, Cheaper," Defense Issues, 11: Number 99 (24 October 1996).
- Kaminski, Paul G. Undersecretary of Defense for Acquisition and Technology. "The Revolution in Defense Logistics," Defense Issues, 10: Number 107 (31 October 1995).
- Killingsworth, Paul S. and Laura Melody. Should C-17s Be Used to Carry In-Theater Cargo During Major Deployments?. Santa Monica CA: RAND, 1997.
- LLMP, Department of the Air Force. USAF Baseline Lean Logistics Master Plan and Road Map, Version 4.0. Washington: HQ USAF/LGM-2, 31 January 1996.
- Lund, John, Ruth Berg and Corinne Replogle. An Assessment of Strategic Airlift Operational Efficiency. Santa Monica CA: RAND, July 1993 (R4269/4-AF).
- Lynn, Larry. "DARPA's Advanced Logistics Program," National Conference on Setting an Intermodal Transportation Research Framework, Conference Proceeding 12:13-22. (4-5 March 1996). Washington: National Academy Press, 1997.
- Mattern, Virginia A. "Inventory Reduction: When is Enough Enough?," Air Force Journal of Logistics: 8-12 (Spring 1997).
- Matthews, James K. and Cora J. Holt. So Many, So Much, So Far, So Fast. Washington: GPO, 1996.
- McHugh, Mary Lou, Asst Deputy Undersecretary of Defense Transportation Policy. "Role of Information Technology in Transportation and Asset Management," Defense Transportation Journal: 30-31 (November/December 1994).

- Moore, Kevin R. Class Handout, LOGM 568, Logistics Management, School of Logistics and Acquisition Management, Air Force Institute of Technology, Wright-Patterson AFB OH, 1997.
- Muczyk, Dr. Jan P. "The Changing Nature of External Threats, Economic and Political Imperatives, and Seamless Logistics," Airpower Journal: 81-92 (Summer 1997).
- Odom, William E. "Transforming the Military," Foreign Affairs, 76: 54-64 (July/August 1997).
- O'Malley, T. J. Lean Logistics and Its Impact on the USAF Spares Requirement, Final Report. McLean VA: Logistics Management Institute, August 1996 (LMI-AF603RD1).
- "Our Strategic Goals," Excerpt from unpublished Defense Logistics Agency document, n.pag. WWWeb, [http://www-dla-mil/strategic\\_plan/goals.htm](http://www-dla-mil/strategic_plan/goals.htm). 2 April 1998.
- Peters, Katherine McIntire. "Supply Siders," Government Executive: 39-43 (September 1997).
- Phillips, Edward H. "FedEx to Launch Multimission, Single Propeller Aircraft". Aviation Week & Space Technology, 16 December 1996:33-34.
- Phillips, John and Lou Chaker. "The future of defense logistics: Making it happen," Logistics Spectrum:11-13 (November 1996).
- Privratsky, Brig Gen Kenneth L. "The Customer is Always Right, Right? (Defense Logistics Agency Section)," Translog: 15 (Fall 1997).
- Pyles, Raymond. RAND Corporation, Washington DC. Personal E-mail. 6 April 1998a.
- Pyles, Raymond. RAND Corporation, Washington DC. Personal E-mail. 22 January 1998b.
- Saunders, Col Mary L. "The Customer is Always Right, Right? (Air Force Section)," Translog: 14 (Fall 1997).
- Schott, Jeffery R. "Transportation Planning," Army Logistician: 14-16 (March/April 1997).
- Sur, Larry. President, Schneider Logistics, Inc. "DoD Transportation System Business Reengineering," Defense Transportation Journal: 31-32 (December 1995).
- Traffic World Staff. "DoD Revamping Logistics Pipeline," TrafficWorld: 32 (6 January 1997) 1997:32.

United States Transportation Command (USTC). Draft Posture Statement for the 105<sup>th</sup> Congress: 1-22. Scott AFB IL, 3 January 1997a.

United States Transportation Command (USTC). Understanding the Defense Transportation System. Handbook 24-2. Scott AFB IL. 1 April 1997b.

Velocity Management Team at the Army Combined Arms Support Command. "Prime Vendor: Velocity Management at DLA," Army Logistician: 4-6 (January-February 1998).

Williams, Capt J.A. HQ AMC/LGXI, Point Paper on Logistics Joint Decision Support Tools (JDST) Requirements. 18 September 1997.

Wilson, Major M. HQ AMC DOZC, Point Paper on Air Mobility Express. 7 January 1998.

Wood, Donald F. and James C. Johnson. Contemporary Transportation. New Jersey: Prentice Hall, 1996.

Zorich, Col David R. "Lean Logistics: Logistics of Tomorrow Today," Logistics for the 21<sup>st</sup> Century. A Special Report by the Supportability Investment Decision Analysis Center (SIDAC): 2-3. Wright-Patterson AFB OH (1996).

## Vita

### **Major Paul J. Judge**

Home Town: Webster, NY

Undergraduate: BA, Mathematics, University of Miami, FL

Graduate: MSA, University of Central Michigan  
Advanced Study of Air Mobility, AFIT

Air Force Assignments: Undergraduate Navigator Training, Mather AFB, CA  
C-130, 345 TAS, Yokota AB, JA  
Undergraduate Pilot Training, Columbus AFB, MS  
C-141, 30 MAS, McGuire AFB, NJ  
HQ Air Mobility Command, Scott AFB, IL  
Air Mobility Warfare Center, Fort Dix, NJ

Follow-on Assignment: TBD

**REPORT DOCUMENTATION PAGE**Form Approved  
OMB No. 074-0188

Public reporting burden for this collection of information is estimated to average 1 hour per response, including the time for reviewing instructions, searching existing data sources, gathering and maintaining the data needed, and completing and reviewing the collection of information. Send comments regarding this burden estimate or any other aspect of the collection of information, including suggestions for reducing this burden to Washington Headquarters Services, Directorate for Information Operations and Reports, 1215 Jefferson Davis Highway, Suite 1204, Arlington, VA 22202-4302, and to the Office of Management and Budget, Paperwork Reduction Project (0704-0188), Washington, DC 20503

1. AGENCY USE ONLY (Leave blank)		2. REPORT DATE June 1998	3. REPORT TYPE AND DATES COVERED Graduate Research Paper	
4. TITLE AND SUBTITLE  THE POTENTIAL INFLUENCE OF ADVANCED LOGISTICS ON DEFENSE AIR TRANSPORTATION			5. FUNDING NUMBERS	
6. AUTHOR(S) Judge, Paul J., Major, USAF				
7. PERFORMING ORGANIZATION NAMES(S) AND ADDRESS(S)  Air Force Institute of Technology 2750 P Street WPAFB OH 45433-7765			8. PERFORMING ORGANIZATION REPORT NUMBER  AFIT/GMO/LAL/98J-10	
9. SPONSORING / MONITORING AGENCY NAME(S) AND ADDRESS(ES)  HQ AMWC/WCDA Ft Dix NJ 08640			10. SPONSORING / MONITORING AGENCY REPORT NUMBER	
11. SUPPLEMENTARY NOTES				
12a. DISTRIBUTION / AVAILABILITY STATEMENT Approved for public release; distribution unlimited.			12b. DISTRIBUTION CODE	
13. ABSTRACT ( <i>Maximum 200 Words</i> ) The Department of Defense (DoD) is entering a period of rapidly evolving logistic business practices and information management technologies. This is largely the result of mandated inventory reductions set forth by Congress. Replacing DoD inventory with logistics process improvement and information systems is now a requirement rather than just a good idea. These efforts are well underway across DoD and are especially apparent at the Defense Logistics Agency (DLA) where programs like Prime Vendor, Direct Vendor Delivery, and Premium Service are turning just-in-case inventory into just-in-time inventory. However, the Advanced Logistics Program (ALP) headed by the Defense Advanced Research Projects Agency (DARPA) stands out among DoD logistics efforts as having the most potential to alter the supply chain in times of war and peace. Specifically, ALP is designed to establish real-time information connectivity across all logistics functions without rendering legacy systems obsolete. When the project is completed in 2002, ALP will rapidly generate courses of actions that decision-makers can employ to ensure tailored logistics effectively supports fluid operations. This advanced logistics environment requires fast and dependable transportation. Therefore, DoD should examine the influence that ALP will have on the defense air transportation system. The full advantage of automated logistics information will not be realized unless air transportation is correctly structured.				
14. SUBJECT TERMS Advanced Logistics Program, Prime Vendor, Direct Vendor Delivery, Premium Service, Air Mobility Express, Civil Reserve Air Fleet, Time Definite Delivery, Inventory Management, Inventory reduction, Automated Logistics Information, Transportation, Airlift, DoD, DLA, USTC, DARPA, AMC, ALP, DLSP, JV2010.			15. NUMBER OF PAGES  71	
			16. PRICE CODE	
17. SECURITY CLASSIFICATION OF REPORT UNCLASSIFIED	18. SECURITY CLASSIFICATION OF THIS PAGE UNCLASSIFIED	19. SECURITY CLASSIFICATION OF ABSTRACT UNCLASSIFIED	20. LIMITATION OF ABSTRACT  UL	

