

203105

JPRS 83101

21 March 1983

19981013 085

# Japan Report

No. 168

MARITIME OBSERVATION SATELLITE PROPOSAL

DTIC QUALITY INFO

DISTRIBUTION STATEMENT A  
Approved for public release;  
Distribution Unlimited

**FBIS**

FOREIGN BROADCAST INFORMATION SERVICE

REPRODUCED BY  
NATIONAL TECHNICAL  
INFORMATION SERVICE  
U.S. DEPARTMENT OF COMMERCE  
SPRINGFIELD, VA 22161

7  
62  
A04

#### NOTE

JPRS publications contain information primarily from foreign newspapers, periodicals and books, but also from news agency transmissions and broadcasts. Materials from foreign-language sources are translated; those from English-language sources are transcribed or reprinted, with the original phrasing and other characteristics retained.

Headlines, editorial reports, and material enclosed in brackets [] are supplied by JPRS. Processing indicators such as [Text] or [Excerpt] in the first line of each item, or following the last line of a brief, indicate how the original information was processed. Where no processing indicator is given, the information was summarized or extracted.

Unfamiliar names rendered phonetically or transliterated are enclosed in parentheses. Words or names preceded by a question mark and enclosed in parentheses were not clear in the original but have been supplied as appropriate in context. Other unattributed parenthetical notes within the body of an item originate with the source. Times within items are as given by source.

The contents of this publication in no way represent the policies, views or attitudes of the U.S. Government.

#### PROCUREMENT OF PUBLICATIONS

JPRS publications may be ordered from the National Technical Information Service, Springfield, Virginia 22161. In ordering, it is recommended that the JPRS number, title, date and author, if applicable, of publication be cited.

Current JPRS publications are announced in Government Reports Announcements issued semi-monthly by the National Technical Information Service, and are listed in the Monthly Catalog of U.S. Government Publications issued by the Superintendent of Documents, U.S. Government Printing Office, Washington, D.C. 20402.

Correspondence pertaining to matters other than procurement may be addressed to Joint Publications Research Service, 1000 North Glebe Road, Arlington, Virginia 22201.

21 March 1983

## JAPAN REPORT

No. 168

### MARITIME OBSERVATION SATELLITE PROPOSAL

Tokyo NEC MOS-1 in Japanese Oct 79 pp 2-27

[Text] This booklet contains the outline of a proposal by Nippon Electric Company [NEC] on the Maritime Observation Satellite No 1 (MOS-1), which was planned by the National Space Development Agency.

The main features of our proposal are listed below.

- We have adopted the bias momentum method, which is based on our past achievement, is reliable, and works very well.
- We propose module construction, which is expandable for future work and easy to integrate.
- Our development work will be based on independent, domestic technology that has grown from local fabrication of many satellites.

MOS-1 will be the first Japanese satellite for observation of the earth. It will serve as a part of the development of the earth observation system, which will contribute to the effective use of our resources and the preservation of our environment. In order to observe maritime phenomena and to establish technology that is common to earth observation satellites, MOS-1 is intended to fulfill the following missions:

- To observe the chromaticity and temperatures of ocean surfaces by a radiometer for visible and near infrared radiation (MESSR), a radiometer for visible and thermal infrared radiation (VTIR), and a microwave radiometer (MSR).
- To learn operating techniques for solar synchronous satellites.
- To learn operating techniques for earth observation satellites.
- To carry out basic experiments in position determination by using a data collection system.
- To establish technology for domestic production of three-axes satellites.

Based on our achievements and experience as the integrator of many domestically produced satellites, NEC has been accumulating technology for three-axes satellites from our own research and development. We have also been developing the MESSR, which is an instrument for the major mission of MOS-1. The development of MOS-1 will be based on these achievements and it will follow the basic policies listed below:

- To utilize locally developed technology based on our achievements and experience as the integrator of more than 10 domestically produced satellites.
- To provide flexible on-board equipment to carry out the satellite's mission, and to assure expanded applications for future satellites.
- To obtain technical support from foreign partners in order to assure the completion of the mission and to minimize risks in development.

Contents	[Original page number]
MOS-1 comprehensive system.....	4
Mission.....	5
Satellite configuration and major data.....	6
Attitude orbit control system.....	10
Power supply and solar cell paddle systems.....	12
Airframe system.....	14
Thermal control system.....	16
Communication and antenna systems.....	18
Telemetry and command systems.....	20
Gas jet system.....	21
Equipment for carrying out the mission.....	22
Launching and operations.....	24

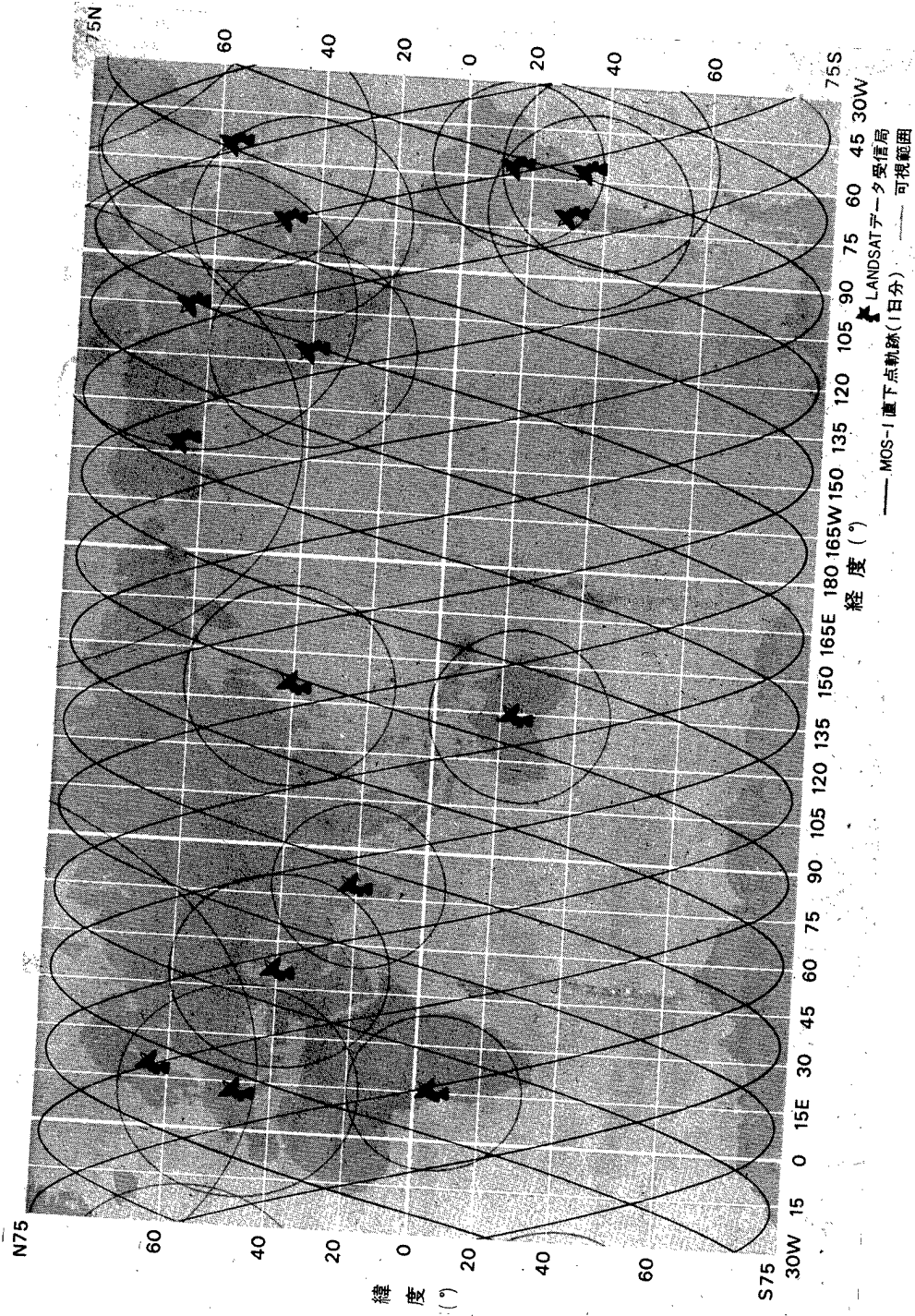

(1)

(4)  
(5)

(2) (3)

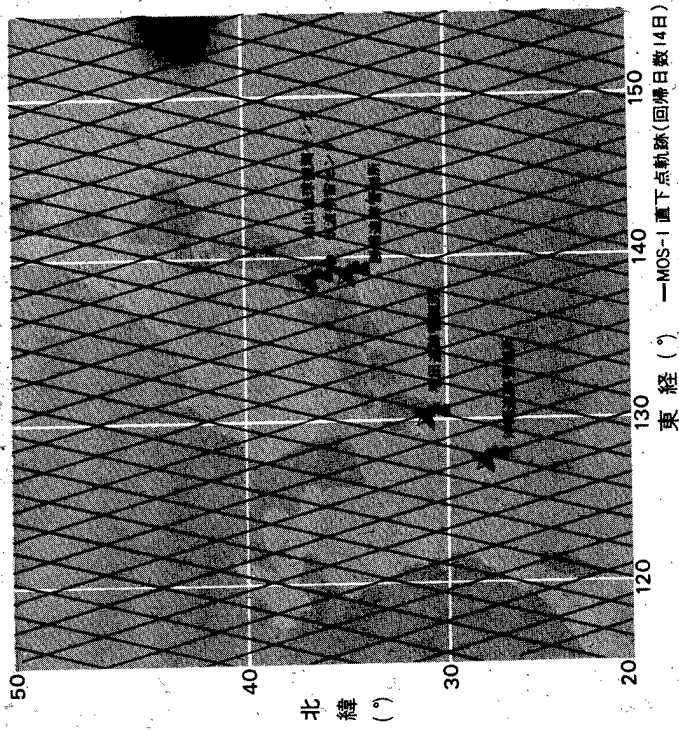

(6)

The MOS-1 comprehensive system consists of the MOS-1 satellite, which circles on a quasi-recurring, solar synchronous orbit at an altitude of 913 km, data receiving stations that receive and utilize observation data, and tracking and control stations that launch, track, and control the satellite. The data transmitted from MOS-1 can be received not only by Japan but also by foreign data receiving stations.

- (9)
- (10)
- (11)
- (12)
- (13)

(7) (8)

Key:

- (1) Latitude
- (2) Longitude
- (3) Terrestrial projection of MOS-1 orbit (one day)
- (4) Landsat data receiving stations
- (5) Visible range
- (6) Northern latitude
- (7) Eastern longitude
- (8) Terrestrial projection of MOS-1 orbit recurs every 14 days
- (9) Hatoyama earth observation center
- (10) Tsukuba earth observation center
- (11) Katsuura tracking control center
- (12) Masuda
- (13) Okinawa

## Satellite Mission

- Oceanic observation by equipment → on board.
- The data observed by MESSR and VTIR are sent to the ground by an 8.4 GHz transmitter. The instruments will be used mainly to observe pollution of the ocean surface, ocean color, sea ice, plant distribution, temperature distribution in the ocean surface, and the distribution of cloud and water vapor.
- The data observed by MSR will be transmitted by USB and telemetry data. The data will be used to observe the distribution of water vapor in the atmosphere and sea and drifting ice.

- To learn how to operate a solar → synchronous satellite.  
The satellite's attitude is arrested immediately after it is separated from its launcher by checking the initial conditions of the satellite. These controls and commands to extend the solar cell paddle will be handled by the Tsukuba Space Center through down range stations in South America. The maintenance of the solar synchronous orbit (the calculation of errors in orbit and attitude and their correction operations) and the operation of the satellite (surveillance of satellite conditions and control manipulations) will also be carried out by the Tsukuba Space Center through tracking and control stations in Okinawa, Katsuura and Masuda.

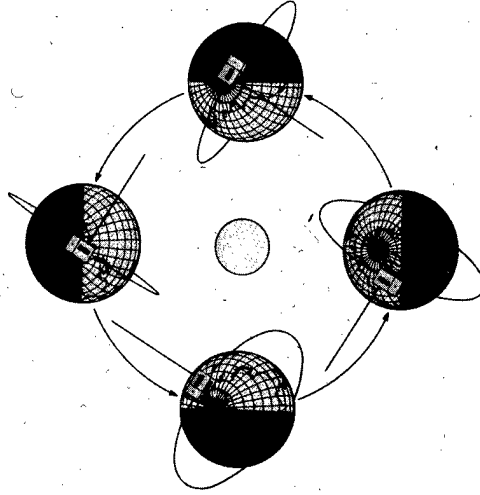
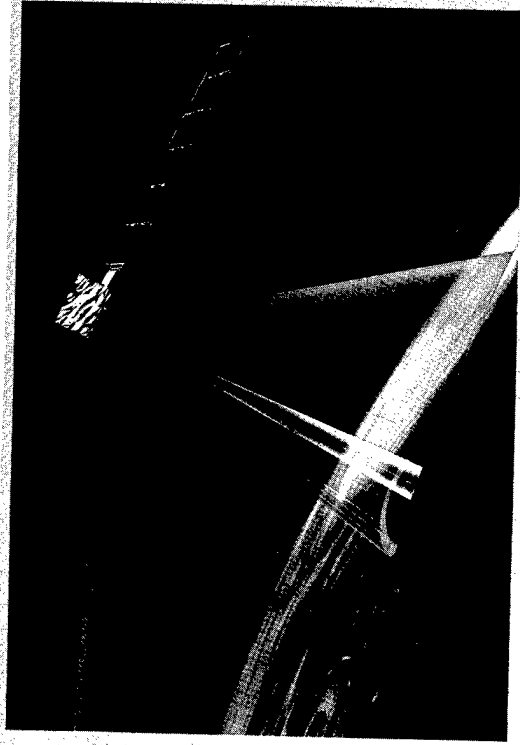

- To learn how to operate an earth observation satellite. →

The observation data will be received mainly by the Earth Observation Center and some overseas data receiving stations. The Earth Observation Center will operate the instruments on board by exchanging information with the Tsukuba Space Center.

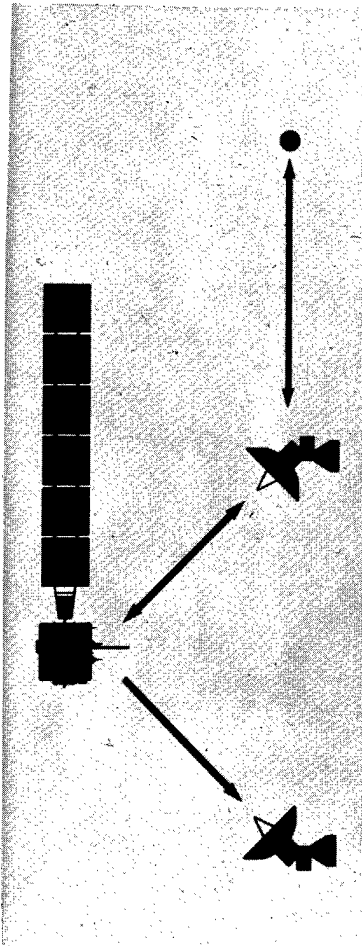

- To carry out basic experiments, such as position determination, using DCS. →

By using relays for the data collection system (DCS), basic experiments in position determination for research and rescue operations will be carried out.

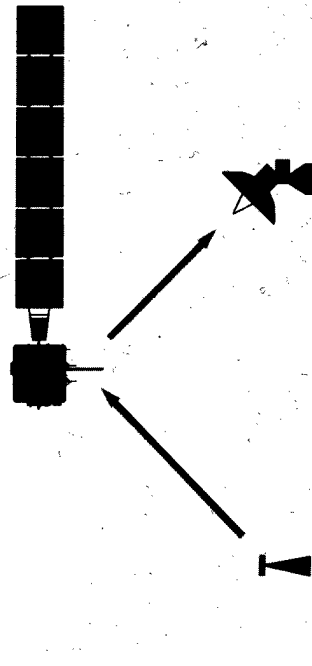

## Satellite Configuration and Major Data

To carry out maritime observation, MOS-1 will be launched in the winter of 1984 from the Tanegashima Space Center by an N-II rocket launcher. The satellite will be put into a solar synchronous orbit of altitude 913 km and inclination 99.1°. The weight of the satellite when it is launched will be about 730 kg.

In this satellite, we have adopted a module construction that has high integration efficiency and can be easily expanded to other tasks. The satellite consists of two rectangular parallelepiped modules, i.e., a bus module and a mission module. Observational instruments and communication antennae are located on the side with the largest area with sufficient fields of vision.

The interface adaptor of the rocket is located at the bottom of the bus module, and the scan wheel assembly is attached on one side. Important instruments such as the attitude orbit control system, the gas jet system, the power supply system, and the telemetry/command system are mounted inside this module.

MESSR, the high speed data transmission section, VTIR, MSR, and the antenna system are mounted on the mission module. The solar cell paddle is also mounted on this module, and it is arranged to optimize the generated power according to the tasks to be performed. The generating capacity of MOS-1 toward the end of its useful life will be 590 watts.

### Special features

- The solar cell paddle is built to form one sheet in order to secure the greatest field of vision for the instruments on board.
- By using the module construction, integration has been made easy and instruments can be expanded for other tasks.
- The bias momentum method has been adopted to improve its reliability and usefulness.
- Thermal control has been made safe by using both passive and active thermal control methods.
- The existing facilities are used effectively by using the same telemetry/command method as the one that is used for ETS-III [satellite]. Stored command and stored data methods are also used, and the satellite can be operated from Japan alone.
- The adopted configuration has sufficient spare electric power, and observed data can be sent to foreign data receiving stations.

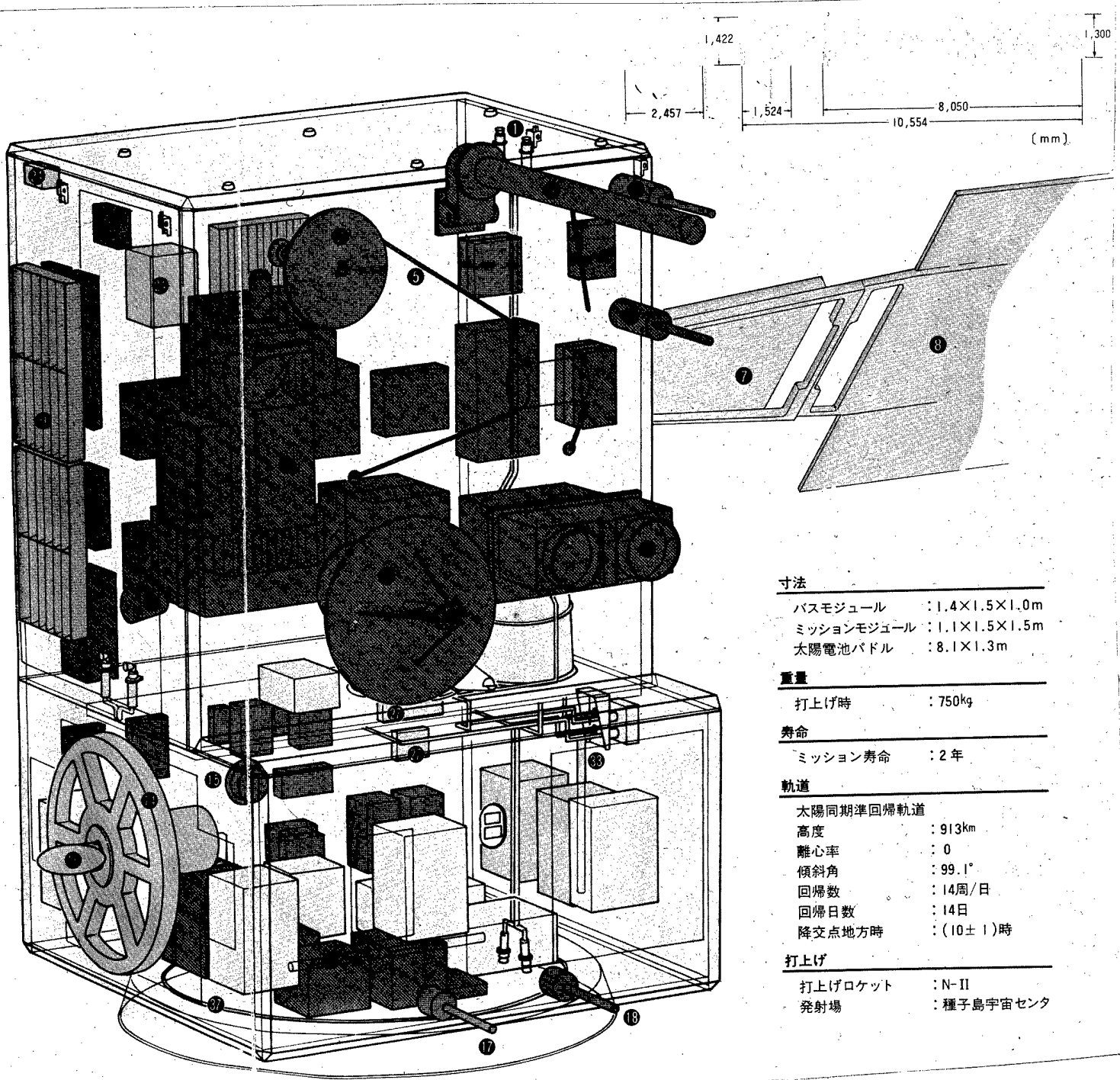

**寸法**

- バスモジュール : 1.4×1.5×1.0m
- ミッションモジュール : 1.1×1.5×1.5m
- 太陽電池パドル : 8.1×1.3m

**重量**

- 打上げ時 : 750kg

**寿命**

- ミッション寿命 : 2年

**軌道**

- 太陽同期準回帰軌道
- 高度 : 913km
- 離心率 : 0
- 傾斜角 : 99.1°
- 回帰数 : 14周/日
- 回帰日数 : 14日
- 降交点地方時 : (10±1)時

**打上げ**

- 打上げロケット : N-II
- 発射場 : 種子島宇宙センタ

# Arrangement of Equipment

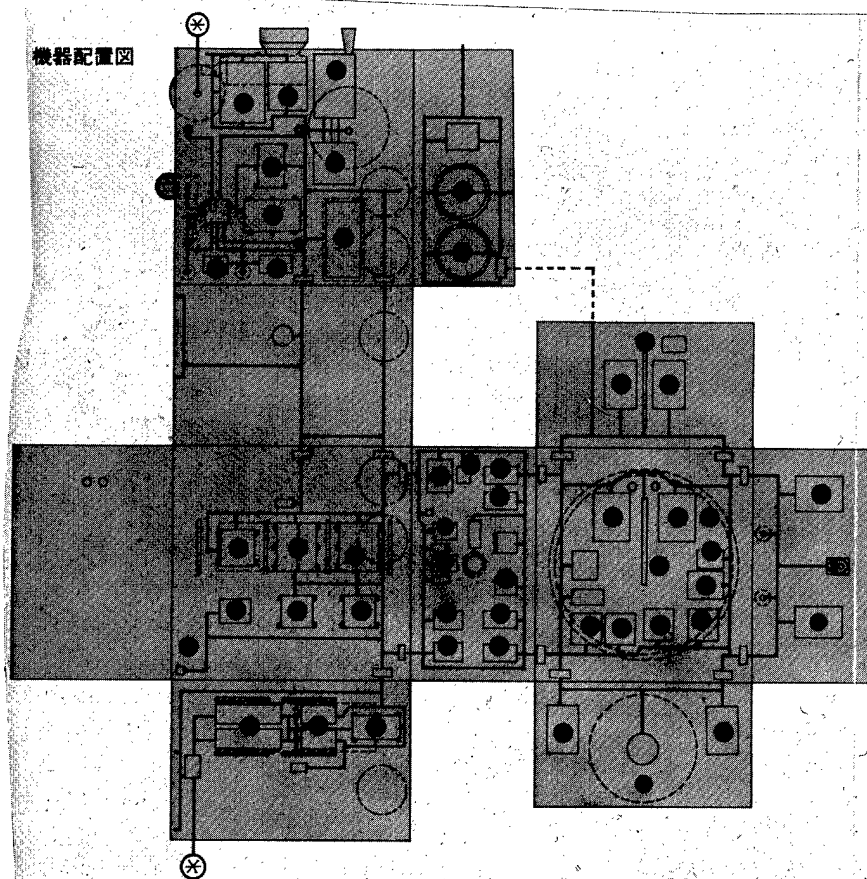

## Key:

- |   |   |
|---|---|
| 1. Thrusters                                    | 24. Terrestrial magnetism sensor and electronic equipment to process the data |
| 2. X-band antenna                               | 25. MESSR signal processing section   |
| 3. DCS/SAR up-link antenna                      | 26. High speed data transmission section                                      |
| 4. USB antenna                                  | 27. Sun sensors and electronic equipment to process the data                  |
| 5. VHF antenna                                  | 28. VHF receivers   |
| 6. DCS/SAR down-link antenna                    | 29. VHF transmitters  |
| 7. Shunt dissipater                             | 30. S-band receivers  |
| 8. Solar cell panel                             | 31. Signal synthesizing circuit   |
| 9. Thermal louver                               | 32. S-band transmitters   |
| 10. Visible, thermal infrared radiometer (VTIR) | 33. Magnetic momentum control coil  |
| 11. Sky horn                                    | 34. Electronic equipment for attitude orbit control                           |
| 12. Microwave radiometer (MSR)                  | 35. Magnetic attitude control coil  |
| 13. Visible, near infrared radiometer (MESSR)   | 36. Boost converters  |
| 14. Momentum wheel                              | 37. Nutation damper   |
| 15. S-band transition antenna                   | 38. Data recorders  |
| 16. Earth sensor                                | 39. Telemetry encoders  |
| 17. S-band up-link antenna                      | 40. Command decoders  |
| 18. S-band down-link antenna                    | 41. Power supply control unit   |
| 19. MSR signal processing and driving sections  | 42. Batteries   |
| 20. MESSR and its controllers                   |   |
| 21. Propellant tanks                            |   |
| 22. DCS/SAR relays                              |   |
| 23. VTIR signal processing section              |   |

Size

Bus module 1.4 x 1.5 x 1.0 m  
Mission module 1.1 x 1.5 x 1.5 m  
Solar cell paddle 8.1 x 1.3 m

Weight

Launch weight 750 kg

Lifetime

Mission lifetime 2 years

Orbit

Solar synchronous, quasirecurring orbit  
Altitude 913 km  
Eccentricity 0  
Inclination 99.1°  
Number of revolutions 14 revolutions/day  
Recurrency period 14 days  
Local time at the descending node 10±1 o'clock

Launching

Launcher N-II  
Launch site Tanegashima Space Center

Attitude orbit control system

Three-axes control method Bias momentum  
Attitude control precision Pitch/roll ±0.2°  
Yaw ±0.7°  
Drift rate Pitch/roll ±0.01°/second  
Yaw ±0.02°/second  
Momentum wheel 100 Nms  
Magnetic attitude control coil 50 ATm<sup>2</sup>  
Magnetic momentum control coil 20 ATm<sup>2</sup>  
Passive nutation damper  
Sensors Conical scanning earth sensor  
Sun sensor  
Terrestrial magnetism sensor

Gas jet system

Orbit control thrusts	1 newton x 6
Propellant	Hydrazine 19.6 kg
Number of tanks	2

Power supply system/solar cell paddle system

Solar cell paddle

Panel driving method	One-axis clock control method
Panel area	10 m <sup>2</sup>
Solar cells	(2 cm x 2 cm) 21,996 cells
Glass cover	0.3 mm thick
Power generation	BOL 670 W; EOL 590 W

Charge regulator type power supply

Bus voltage	29V
Batteries	NiCd 15 AH x 3

Satellite power consumption

	519 W (148 W for bus equipment, 371 W for mission equipment)
--	---

Airframe System

Modular bus mission equipment  
Single sheet panel (folded six times)

Size

Bus module	1.4 x 1.5 x 1.0 m
Mission module	1.1 x 1.5 x 1.5 m
Solar cell panels	8.1 x 1.3 m

Weight

Total	About 750 kg
Bus equipment	470 kg
Mission equipment	212 kg
Propellant	20 kg
Margin	49 kg

Thermal control system

Active thermal control	Thermal louvers, heaters, bimetals
Passive thermal control	Radiators, thermal blankets, condensers

Communication system/antenna system

VHF	Telemetry Command	136 MHz 148 MHz	} Monopole antenna x 4	
UHF	DCS/SAR up	406 MHz		
L-band	DCS/SAR down	1543 MHz	Quadrifilar helical antenna x 1	
S-band	Telemetry R & RR	1.7 GHz	} {Quadrifilar helical antenna x 2 Spiral antenna (for transition)x1	
	Command R & RR			2.1 GHz
	R & RR			2.1 GHz
USB	Telemetry MSR	2.2 GHz	Quadrifilar helical antenna x 1	
X-band	MESSR, VTIR	8.4 GHz	Turnstyle antenna x 1	

Telemetry/command system

Data stored during the invisible period and high speed playback during the visible period

Stored commands

Telemetry encoder

Bit rate	1,024 bps
Number of entry	About 480

Command decoder

Bit rate	128 bps
Number of entry	Maximum 252 (real time) Maximum 16 (stored)

Data recorder

Input channel	1 channel (2 tracks)
Bit rate	1,024 bps (recording) 26,624 (playback)
Playback/record ratio	26/1
Recording time	Minimum 105 minutes
Playback time	Minimum 4 minutes

Mission equipment

MESSR

Band 1 0.5 - 0.6  $\mu\text{m}$   
2 0.6 - 0.7  $\mu\text{m}$   
3 0.7 - 0.8  $\mu\text{m}$   
4 0.8 - 1.1  $\mu\text{m}$

VTIR

Band 1 0.5 - 0.7  $\mu\text{m}$   
2 6.0 - 7.0  $\mu\text{m}$   
3 10.5 - 11.5  $\mu\text{m}$   
4 11.5 - 12.5  $\mu\text{m}$

MSR

Band 1 23 GHz  
2 31 GHz

DCS/SAR relay (DCS/SAR)

Up 406 MHz  
Down 1,543 MHz

# System functions

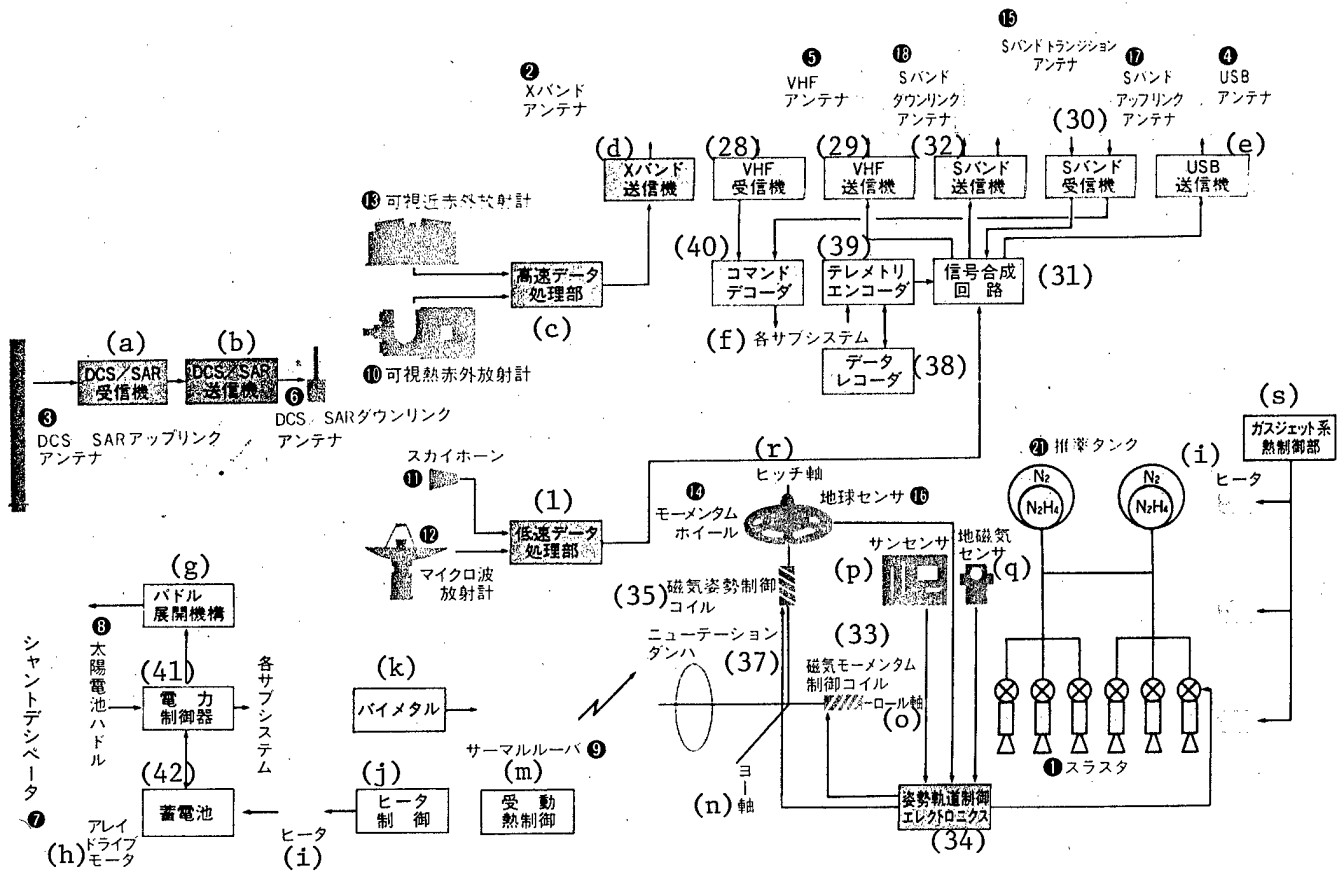

- Key:
- (a) DCS/SAR receiver
  - (b) DCS/SAR transmitter
  - (c) High speed data processing section
  - (d) X-band transmitter
  - (e) USB transmitter
  - (f) Each subsystem
  - (g) Paddle extension mechanism
  - (h) Array drive motor
  - (i) Heater
  - (j) Heater control
  - (k) Bimetal
  - (l) Low speed data processing section
  - (m) Passive thermal control
  - (n) Yaw axis
  - (o) Roll axis
  - (p) Sun sensor
  - (q) Terrestrial magnetism sensor
  - (r) Pitch axis
  - (s) Gas jet system, thermal control section

[key continued]

[continuation of key]

1. Thrusters
2. X-band antenna
3. DCS/SAR up-link antenna
4. USB antenna
5. VHF antenna
6. DCS/SAR down-link antenna
7. Shunt dissipater
8. Solar cell panel
9. Thermal louver
10. Visible, thermal infrared radiometer (VTIR)
11. Sky horn
12. Microwave radiometer (MSR)
13. Visible, near infrared radiometer (MESSR)
14. Momentum wheel
15. S-band transition antenna
16. Earth sensor
17. S-band up-link antenna
18. S-band down-link antenna
19. MSR signal processing and driving sections
20. MESSR and its controllers
21. Propellant tanks
22. DCS/SAR relays
23. VTIR signal processing section
24. Terrestrial magnetism sensor and electronic equipment to process the data
25. MESSR signal processing section
26. High speed data transmission section
27. Sun sensors and electronic equipment to process the data
28. VHF receivers
29. VHF transmitters
30. S-band receivers
31. Signal synthesizing circuit
32. S-band transmitters
33. Magnetic momentum control coil
34. Electronic equipment for attitude orbit control
35. Magnetic attitude control coil
36. Boost converters
37. Nutation damper
38. Data recorders
39. Telemetry encoders
40. Command decoders
41. Power supply control unit
42. Batteries

Table. Allocation of Weight, Electric Power and Reliability

	Weight allocation (kg)	Electric power allocation (watt)	Reliability allocation
Attitude orbit control system	50.7	14.3*1	0.8971
Telemetry/command system	32.0	32.1	0.9725*8
Communication system	20.1	30.6*2	0.9725
Antenna system	10.7	--	0.9938
Power supply system	94.8*3	20.0*4	0.9545
Solar cell paddle system	57.4*5	13.0	0.9399
Gas jet system	18.9	16.0*6	0.9516
Airframe system	120.0	--	0.9877
Thermal control system	20.0	22.0*7	0.9846
Mechanical and electrical instrumentation	45.0	--	(Included in the frame)
Bus instruments	469.6	148.0	0.700*8
MESSR	134.6	200.2	
VTIR	20.0	35.0	
MSR	54.0	120.0	
DCS/SAR relay	3.3	16.0	
Mission instruments	211.9	371.2	0.794
Satellite dry weight	681.5	371.2	
Propellant	19.6	--	
Margin	48.9	--	
Satellite total	750.0	519.2	0.5*8

\*1: Increases by 1.0 watt during roll/yaw control, and by 1.3 watts during unloading.

\*2: Increases by 6 watts when VHF TX is turned on.

\*3: Includes the weight of solar cells.

\*4: Increases by a maximum of 83.8 watts when the boost converter is used.

\*5: Does not include the weight of solar cells.

\*6: Increases by 6 watts when a heater is used, and by 9.8 watts when a thruster is blasting.

\*7: When a heater is on for orbit [control] only, while mission instruments are turned off.

\*8: Excludes the data recorder (allocation 0.9).

## Attitude Orbit Control System

The bias momentum method is used for the attitude orbit control system. The roll/yaw attitude and pitch control are maintained by a momentum wheel. The unloading and the roll/yaw control of the momentum wheel are controlled by a magnetic control method. Nutation of the satellite after its separation [from the launcher] is removed by a passive nutation damper, and nutation during the orbital operation is removed by an active nutation control. All attitude controls are carried out on board [i.e., not by command from the ground].

- Notable design characteristics
- Reliability and operability are secured by using the bias momentum method.
- Reliability and durability are secured by using a magnetic torquer.
- Long frequency nutation is removed by an active nutation damper.
- Operations are simplified through on-board processing.

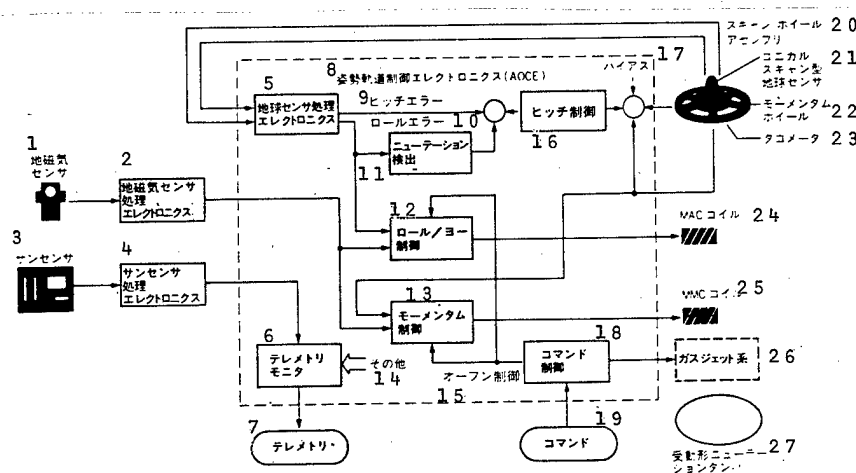

### Key:

- |   |   |
|---|---|
| 1. Terrestrial magnetism sensor   | 13. Momentum control                          |
| 2. Electronic equipment for processing the terrestrial magnetism sensor | 14. Others                                    |
| 3. Sun sensors  | 15. Often [transliteration uncertain] control |
| 4. Electronic equipment for processing sun sensors                      | 16. Pitch control                             |
| 5. Electronic equipment for processing the earth sensor                 | 17. Bias                                      |
| 6. Telemetry monitor  | 18. Command control                           |
| 7. Telemetry  | 19. Command                                   |
| 8. Attitude orbit control electronic equipment (AOCE)                   | 20. Scan wheel assembly                       |
| 9. Pitch error  | 21. Conical scan type earth sensor            |
| 10. Roll error  | 22. Momentum wheel                            |
| 11. Detection of nutation   | 23. Tachometer                                |
| 12. Roll/yaw control  | 24. MAC coil                                  |
|   | 25. MMC coil                                  |
|   | 26. Gas jet system                            |
|   | 27. Passive nutation damper                   |

Major Performance Data for the Attitude Orbit Control System

Attitude control precision Pitch/roll  $\pm 0.2^\circ$ , yaw  $\pm 0.7^\circ$   
 Attitude drift rate Pitch/roll  $\pm 0.01^\circ/\text{sec}$ , yaw  $\pm 0.02^\circ/\text{sec}$   
 Orbit maintenance precision Altitude  $913 \text{ km} \pm 390 \text{ m}$   
 Orbit control capability Velocity correction to correct [orbit]  
 Insertion errors:  
     In-plane control 14.2 m/sec  
     Out-of-plane control 12.9 m/sec  
     Velocity correction to maintain  
     fundamental orbit:  
         In-plane control 10.2 m/sec

Sun sensors  
 Type : Digital  
 Resolution : 1/256°  
 Precision : 1'  
 Field of vision :  $64^\circ \times 64^\circ$

Terrestrial magnetism sensor

Type : Flux gate  
 Measurement range :  $\pm 50,000\gamma$  (all three gates)  
 Precision : Less than  $\pm 500\gamma$

Momentum wheel

Moment : 100 Nms  
 Control torque : 0.66 Nms  
 Rotation rate : 750 rpm  $\pm 10$  percent  
 Friction torque : 0.06 Nm

Earth sensor

Type : Conical scan (mounted on the momentum wheel)  
 Revolution rate : 750 rpm  $\pm 10$  percent  
 Precision : Pitch  $\pm 0.14^\circ$ , roll  $\pm 0.09^\circ$   
 Measurement wavelength : 14 - 16  $\mu\text{m}$

Passive nutation damper

Inner diameter of tube : 30 mm $\phi$   
 Center diameter of tube : 1,100 mm $\phi$   
 Sealed liquid : Silicon oil (cst)  
 Nutation damping time constant : 2.3 hours

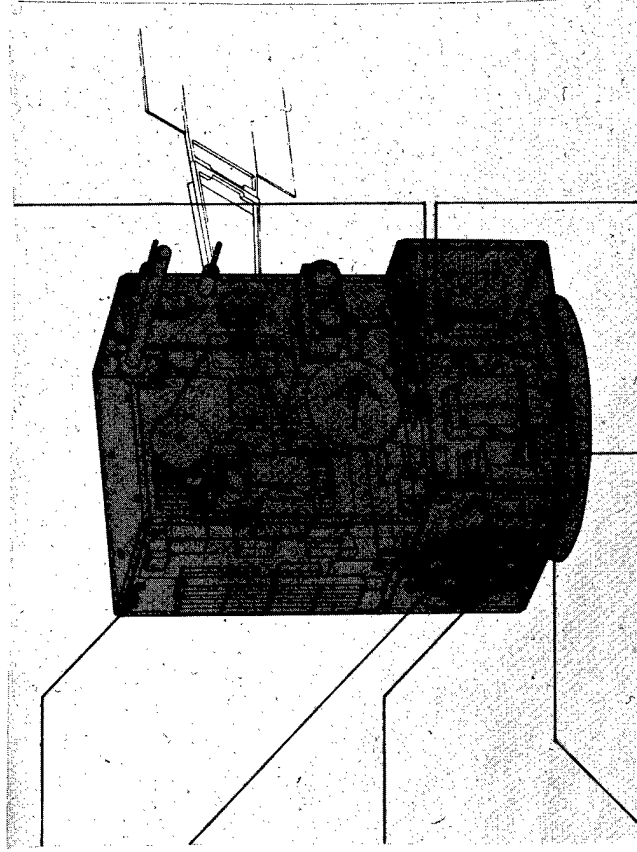

Magnetic attitude control coil  
 Maximum rated magnetic moment: 50 ATm<sup>2</sup>  
 Shape : 64cmx2.6cm $\phi$   
 (constant-current drive, duplex winding coil with core)

Magnetic momentum control coil  
 Maximum rated magnetic moment: 20 ATm<sup>2</sup>  
 Shape : 49cmx1.9cm $\phi$   
 (constant-current drive, duplex winding coil with core)

[Attitude Orbit Control System]

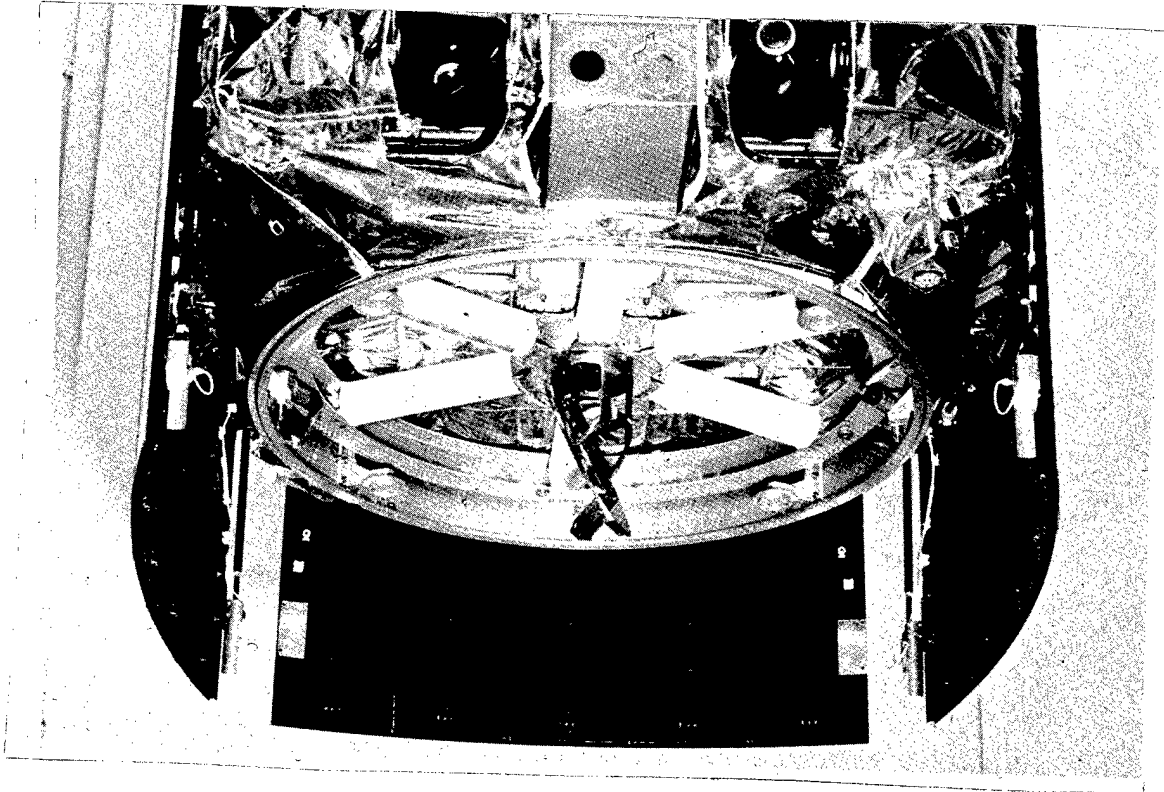

ITOS scan wheel assembly

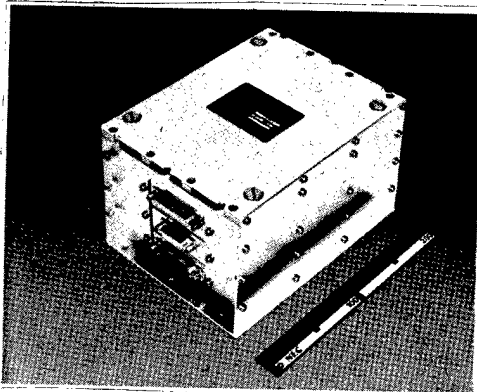

Electronic equipment to process [the data from] the terrestrial magnetism sensor

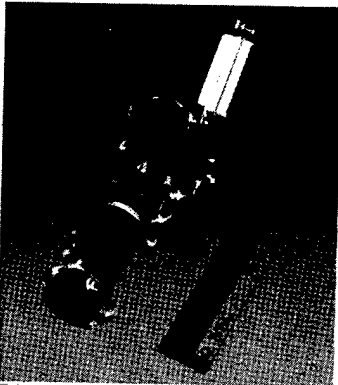

Terrestrial magnetism sensor

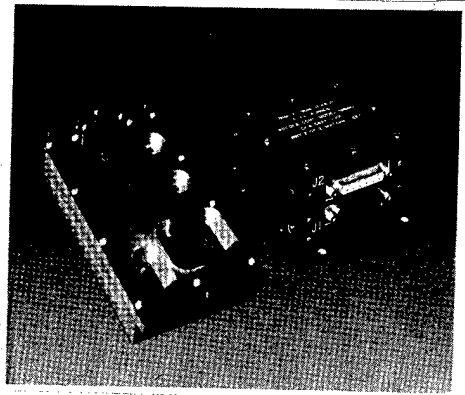

Sun sensor

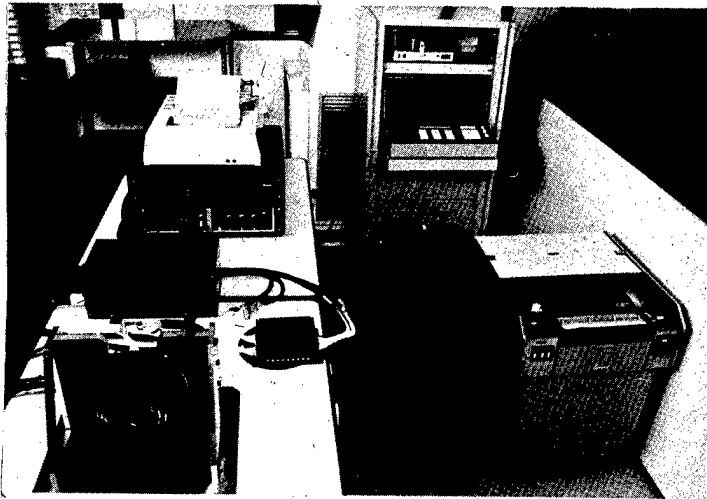
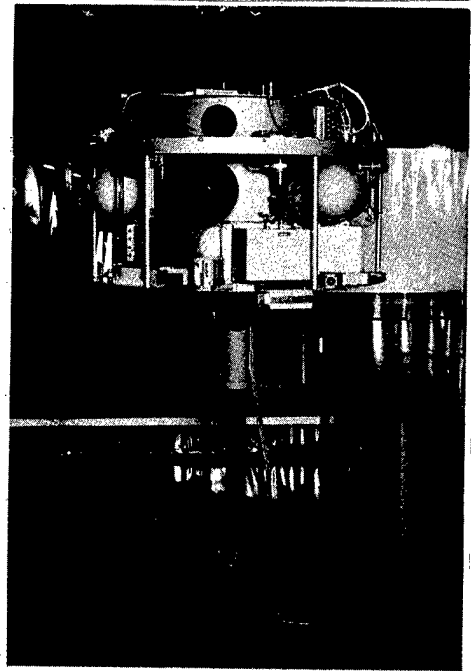
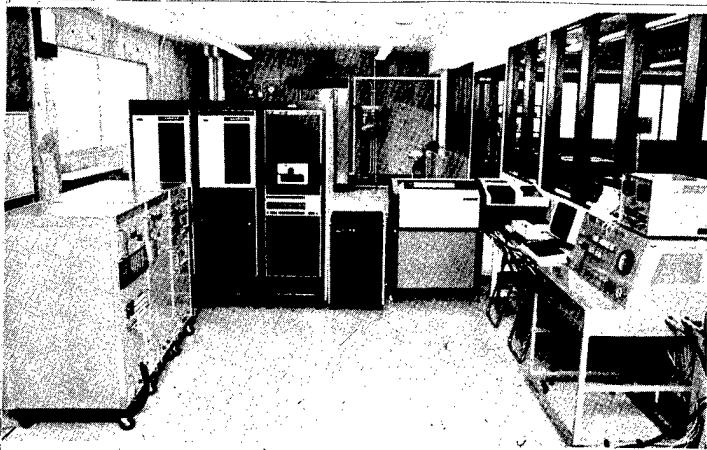

Upper left : Dynamic simulator (computer section)  
Lower left : Dynamic simulator (air bearing section)  
Right : MS-T4 momentum wheel and its testing apparatus

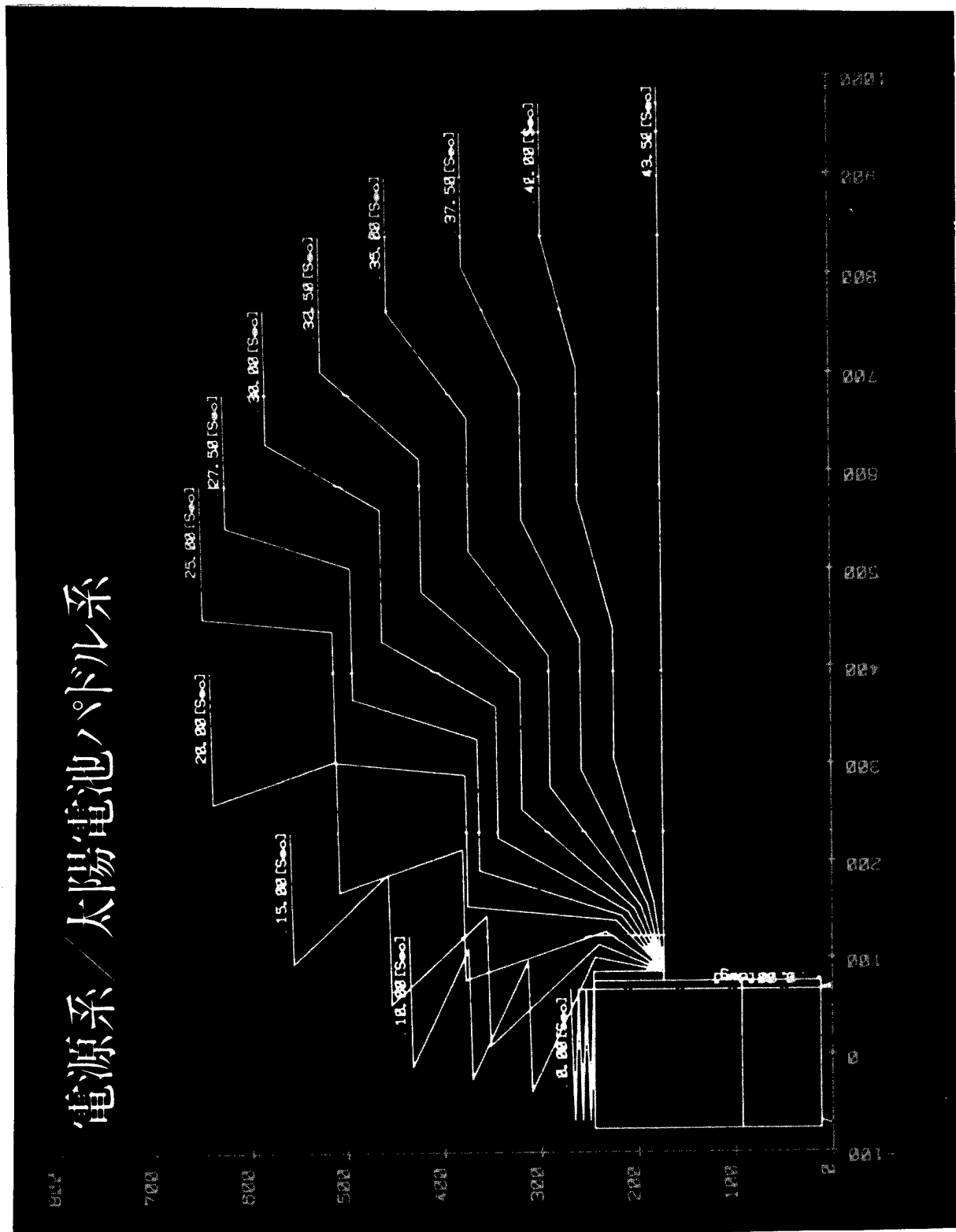

The power supply system provides uninterrupted electric power needed by the mission and bus equipment for 2 years during which the satellite performs its tasks. The electric power is generated by using the solar cells, and batteries are used when the satellite is in shadow.

To adapt to a solar synchronous orbit and to secure a field of vision for the mission equipment, the solar cell paddle has a single-sheet paddle configuration. The batteries consist of a 3-system parallel configuration. They are controlled by the charge regulator method, which has good electric power efficiency and bus voltage stability. For the shunt method, a sequence controlled through the partial shunt method, which enables a reduction of equivalent heat generation, is used. To decrease the number of power slip rings, the shunt dissipator was mounted on the paddle side, and the shunt resistance was mounted on the back side of the paddle to achieve better heat dissipation.

Power supply system data

Solar cell	2 cm x 2 cm N/P silicon solar battery cell, a total of 94 x 234 = 21,996 sheets. 0.3 mm glass cover Generated power: BOL 670 watts, EOL 590 watts
Battery	Square, sealed Ni-Cd secondary batteries 15 AH x 17 in series x 3 systems Maximum discharge depth: at launch 34 percent, during operation 16 percent
Power controller	Charge mode/discharge mode/shunt mode: automatic switching Stabilized voltage 29V ± 2 percent
Shunt dissipator	Partial shunt method 24 circuits sequential control Maximum shunt processing capability: about 700 watts
Boost converter	More than 400 watts
Ordinance control circuit	Current with extended paddle 30 A (20 ms)

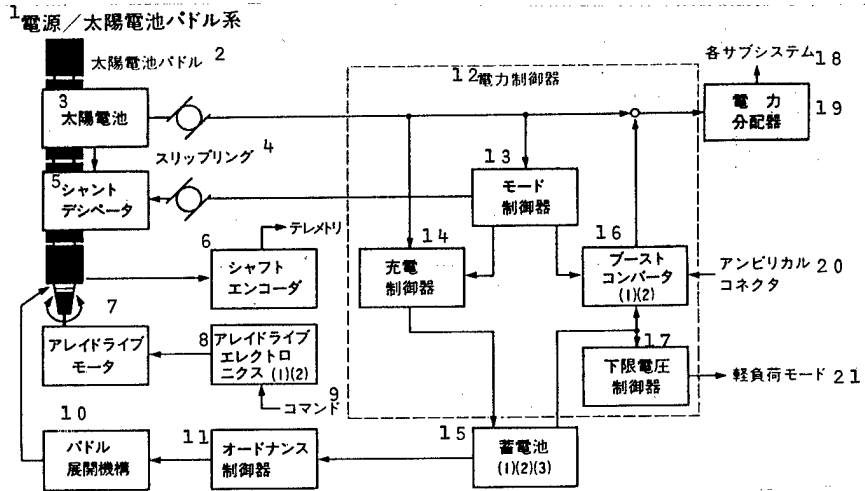

Key:

- |  |                                    |
|--|------------------------------------|
| 1. Power supply/solar cell paddle system | 11. Ordnance controller            |
| 2. Solar cell paddle                     | 12. Power controller               |
| 3. Solar cell                            | 13. Mode controller                |
| 4. Slip rings                            | 14. Charge controller              |
| 5. Shunt dissipator                      | 15. Batteries (1) (2) (3)          |
| 6. Shaft encoder                         | 16. Boost converters (1) (2)       |
| 7. Array drive motor                     | 17. Lower limit voltage controller |
| 8. Array drive electronics (1) (2)       | 18. Each subsystem                 |
| 9. Command                               | 19. Power distributor              |
| 10. Paddle extension mechanism           | 20. Umbilical connector            |
|  | 21. Light load mode                |
|  | 22. Telemetry                      |

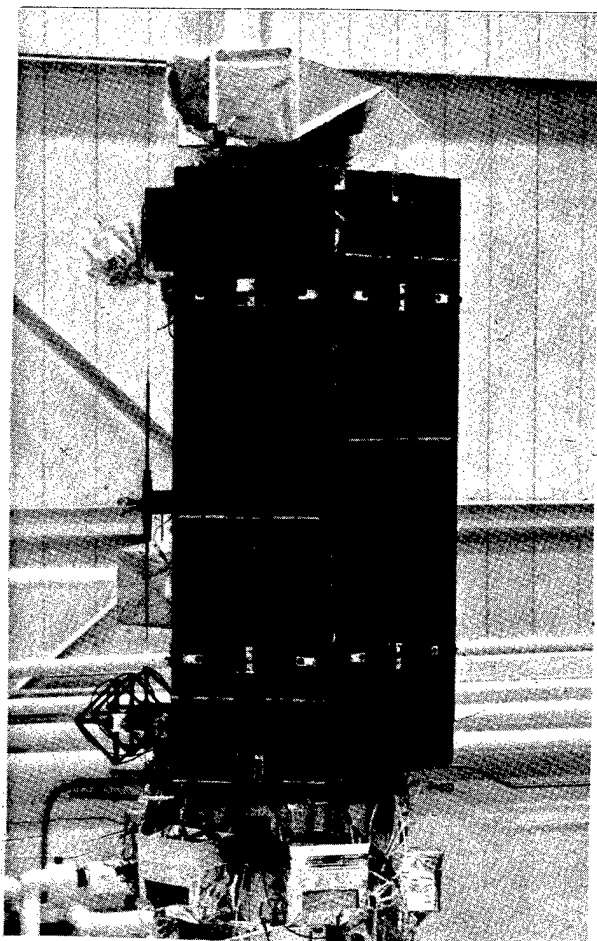

TIROS-N solar cell paddle

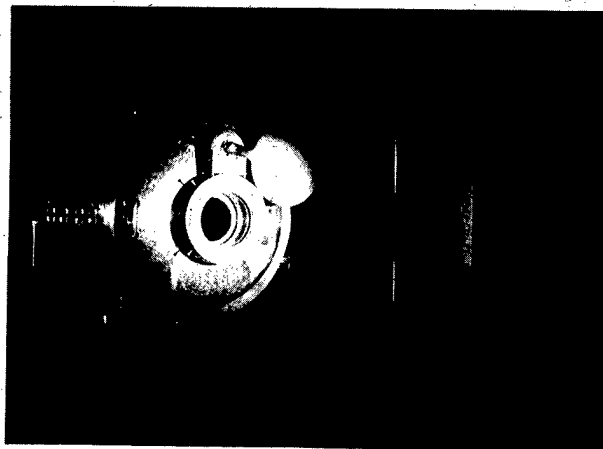
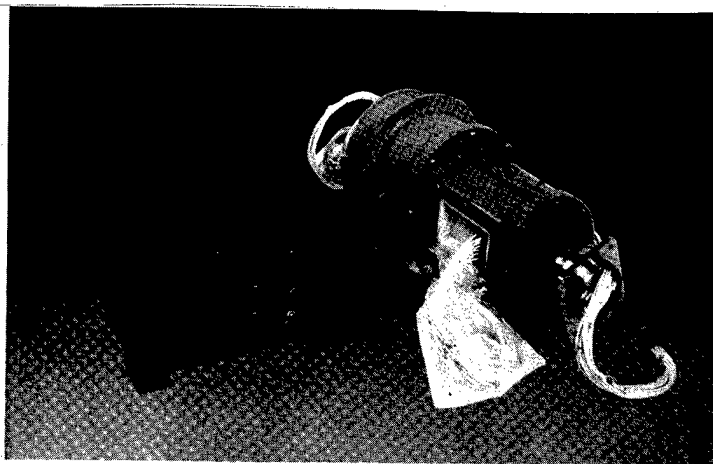

Upper: Array drive motor and electronics  
Lower: Solar simulator

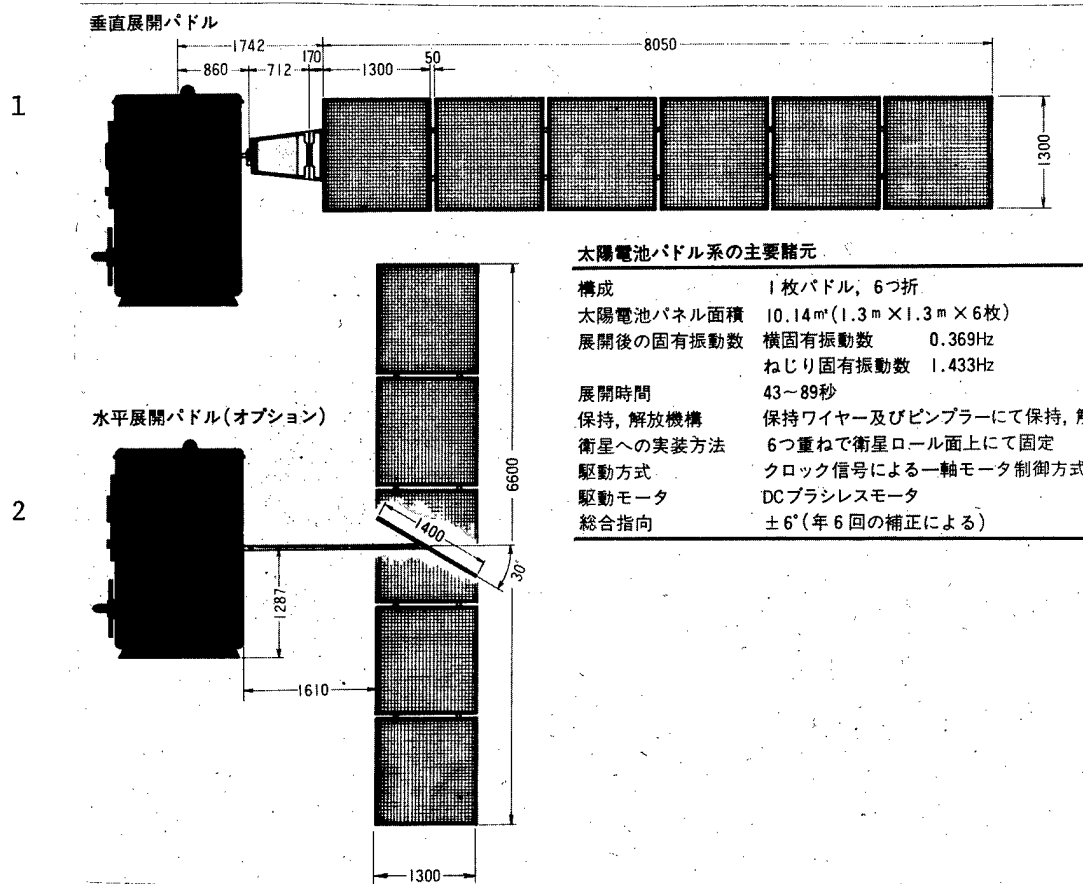

Key: 1. Vertically extended paddle

2. Horizontally extended paddle (optional)

#### Major data for the solar cell paddle system

Configuration	Single sheet paddle, folded six times
Area of the solar cell panel	10.14 m <sup>2</sup> (1.3 m x 1.3 m x 6 sheets)
Characteristic frequency after the paddle is extended	Lateral proper frequency 0.369 Hz Twist proper frequency 1.433 Hz
Time required for extension	43-89 seconds
Retention and release mechanisms	Retention wire and pimpler are used for retention and release
Mounting method on the satellite	Folded six times and mounted on the satellite's roll side
Drive method	Single axis motor control by clock signals
Drive motor	DC brushless motor
Combined directionality	±6° (through 6 adjustments per year)

Airframe System



Space environment laboratory in which integration and testing of MOS-1 are carried out.

The airframe consists of a mission module, which houses mission equipment, and a bus module, which contains shared equipment. Each module uses an outer shell structure method that does not have a main frame.

- Design characteristics
- The frame was designed to make integration easier by dividing it into the mission and bus modules.
- Future expandability is guaranteed by adopting the module structure.
- The outer shell structure facilitates instrumentation and checkout and efficiently uses the space that is available for mounting [the instruments].

#### Satellite structure, major dimensions, and weight

Dimensions	1.4m (length) x 1.5m (width) x 2.5m (height)
Mission module	1.1m (length) x 1.5m (width) x 1.5m (height)
Bus module	1.4m (length) x 1.5m (width) x 1.0m (height)
Weight	
Mission module	65.7 kg
Bus module	<u>54.3 kg</u>
	120.0 kg

#### Major structural materials

##### Mission module panel

30/40mm honeycomb sandwich structure  
Surface panel made of high strength aluminum alloy  
Core made of corrosion resistant aluminum alloy

##### Bus module panel

30/40mm honeycomb sandwich structure  
Surface panel made of high strength aluminum alloy  
Core made of corrosion resistant aluminum alloy

##### Adaptor ring

Machine processed  
High strength, forged aluminum alloy

#### Results of structural analysis

##### Proper frequency (at launch)

Thrust axis direction, primary 61 Hz  
Lateral, primary 16 Hz

Proper frequency (in orbit) 0.37 Hz

##### Safety tolerance rate of major structural materials

Mission module earth panel 2.6  
Mission module panel 3.4  
Bus module base panel 1.7  
Bus module panel 1.4  
Adaptor ring 1.6

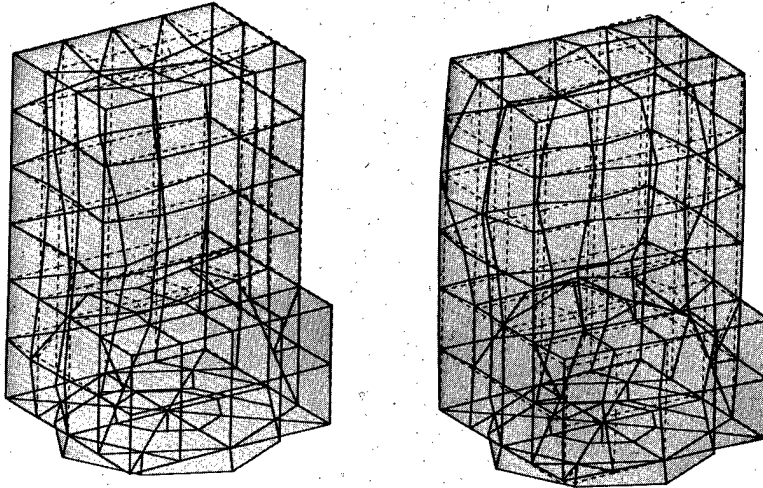

Key: [to page 29 diagram]

1. Composition of airframe system
2. Base panel
3. Adaptor ring
4. Sun panel
5. Space panel
6. Anti-earth panel
7. Earth panel
8. Tank panel
9. Velocity panel
10. Upper panel
11. Solar cell paddle

1  
2  
3  
4  
5  
6  
7  
8

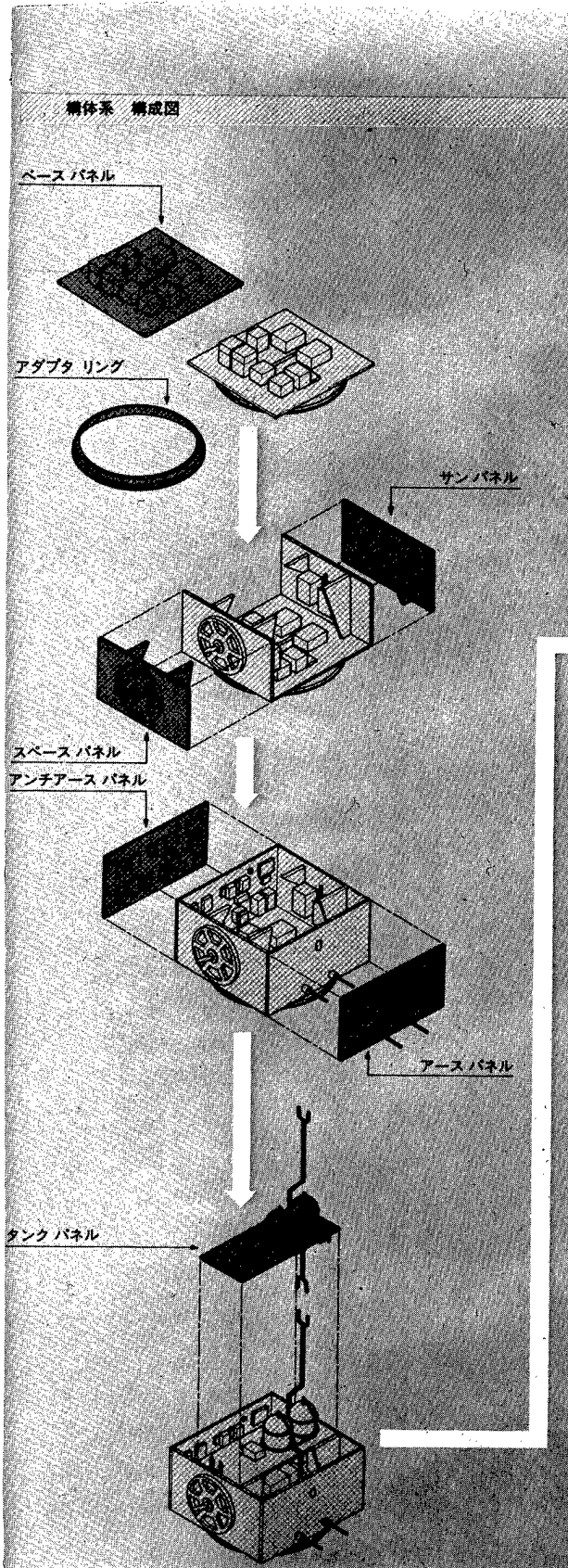

9  
4  
5  
7  
6  
10  
11

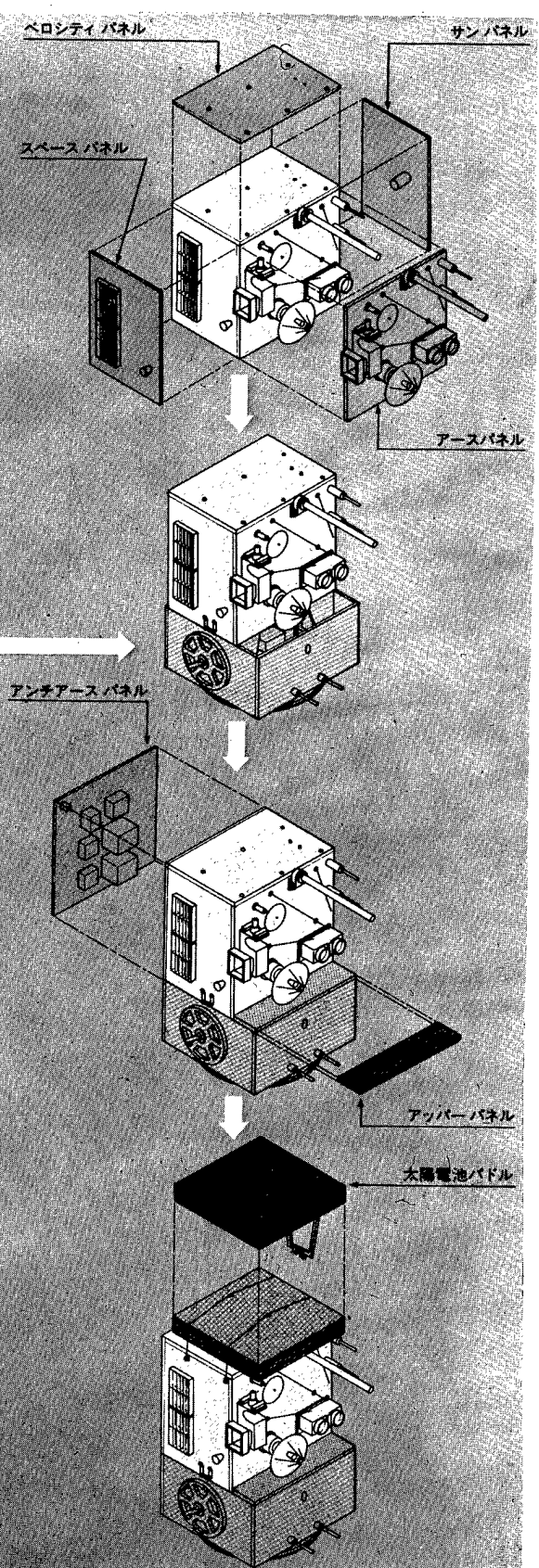

## Thermal Control System

The thermal control system is based on a passive method, but it uses some active modes (thermal louver and heater) as well. The satellite surface consists of two panels. One panel actively controls thermal conditions by making its surface dissipate heat efficiently, while the other panel restricts heat exchange with the outside by insulating its surface with thermal blankets. The main part of the thermal control panel is the pitch side, and the auxiliary parts are the yaw side and roll side.

The equipment in the bus system is mostly installed on the heat dissipation side of the thermal control panel, and the apparatus in the mission system that generates much heat is equipped with thermal louvers. The interior of the satellite is painted black to make the inside temperature of the satellite uniform. The gas jet system is equipped with a heater in order to prevent chilling. The temperature of the batteries is also controlled by a heater.

- Design characteristics
- Design is based on the passive type, which our company has much experience with, while the active type is also used to create an environment with safe temperatures.
- Operation is made much simpler by using thermal control elements which are driven and controlled on board.

### Thermal control system data

#### Electric power for heaters

Battery 22 watts

Gas jet system

(excluding the catalytic heater) 15 watts

#### Thermal louvers

0.25m x 0.3m 10 units

0.2 m x 0.22m 1 unit

0.4 m x 0.22m 1 unit

#### Passive heat dissipation surface

Total area About 13.7m<sup>2</sup>,  $\epsilon = 0.67$

#### Design temperatures

##### Margins for operating temperatures

Critical apparatus 0°C (Required: 0°C or higher)

Other apparatus 15°C (Required: 15°C or higher)

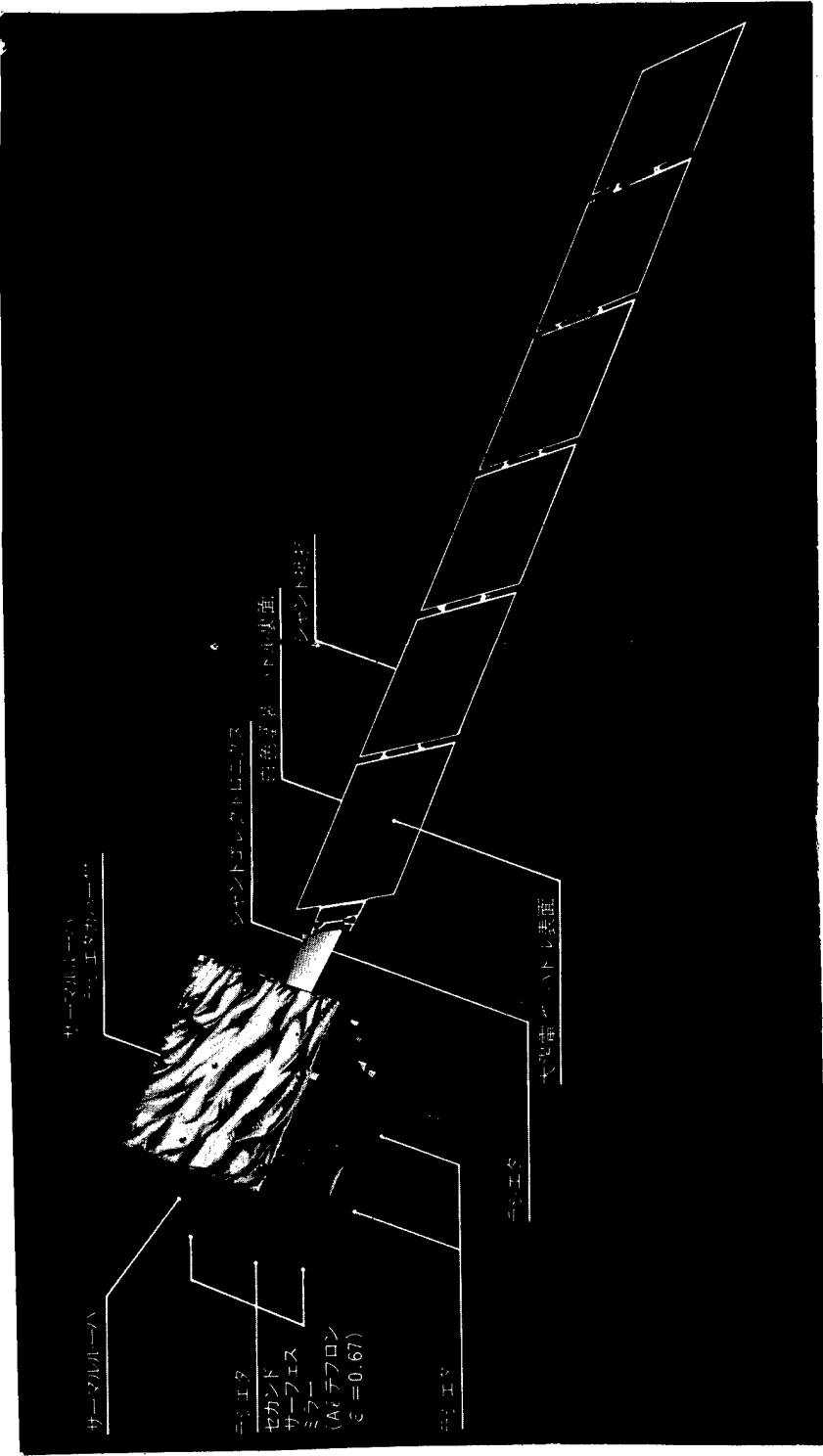

- 1
- 2
- 3
- 2
- 2
- 9
- 4

Sketch of the Thermal Control System

- Key:
- 1. Thermal louver
  - 2. Radiator
  - 3. Second surface mirror ( $A\lambda$  teflon,  $\epsilon = 0.67$ )
  - 4. Direction of the earth
  - 5. Thermal louver (with a radiator cover)
  - 6. Shunt electronics
  - 7. Painted white (back side of the paddle)
  - 8. Shunt resistance
  - 9. Solar cells (paddle surface)

熱制御系 構成

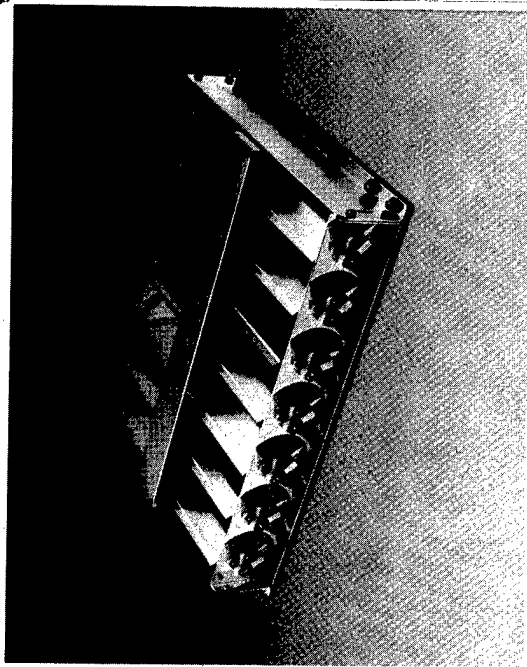
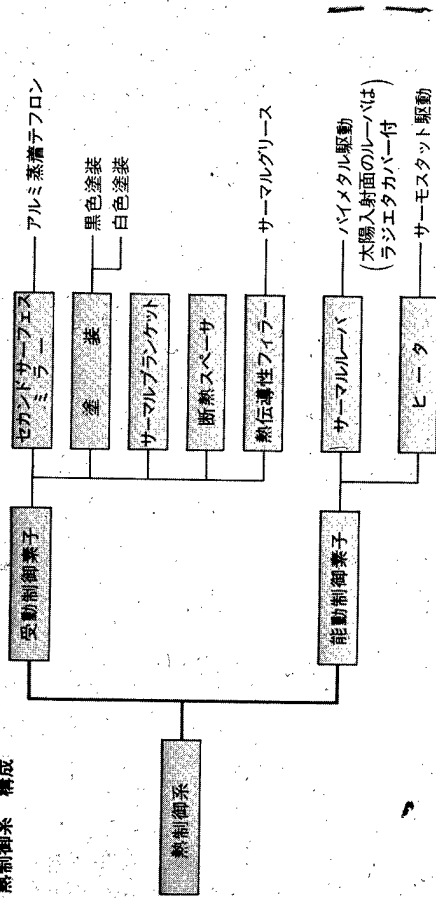

Test sample of a thermal louver

12-17

Key: 1. Composition of the thermal control system

- 2. Thermal control system
- 3. Passive control elements
- 4. Active control elements
- 5. Second surface mirror
- 6. Painting
- 7. Thermal blanket
- 8. Insulation spacer
- 9. Heat conductive filler

10. Thermal louvers

- 11. Heaters
- 12. Aluminum evaporated teflon
- 13. Painted black
- 14. Painted white
- 15. Thermal grease
- 16. Driven by bimetal  
(the louver that faces the sun has a radiator cover)
- 17. Driven by thermostats

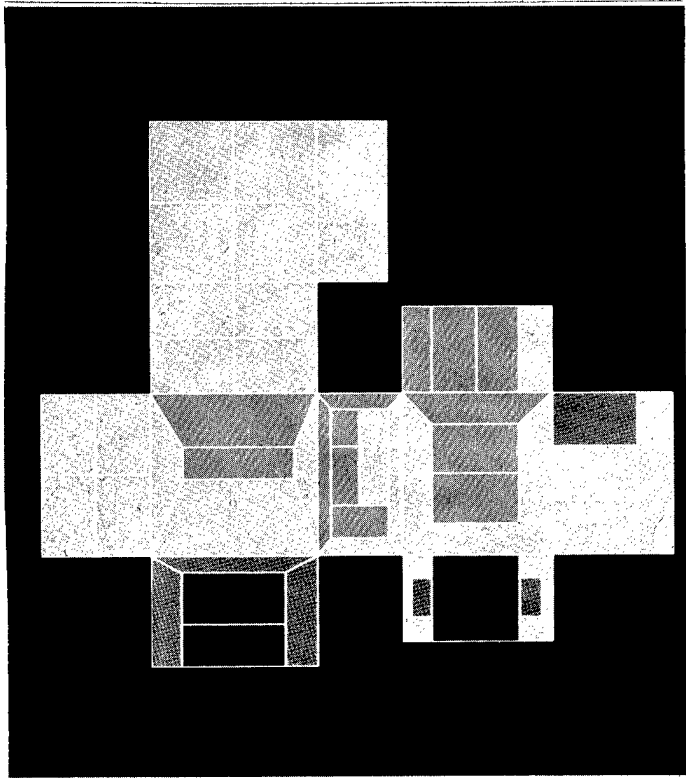

Anticipated  
temperatures  
(upper limit)

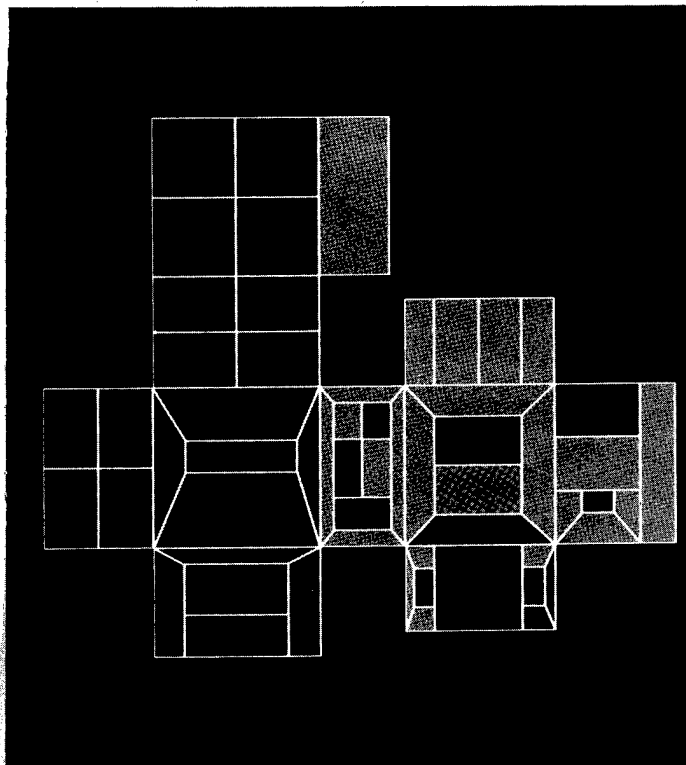

Anticipated  
temperatures  
(lower limit)

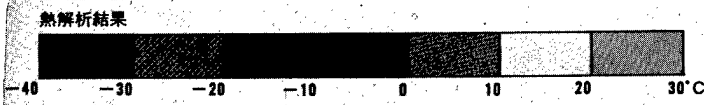

Color chart for the  
thermal analysis results

# Communication System/Antenna System

The communication subsystem consists of telemetry, a command system, an observation data transmission system, and a data collection system/search and rescue experimental system.

- Design characteristics
- TT&C system used methods that were also used on the ETS-III satellite as much as possible.
- The S-band range finding can be carried out by two stations simultaneously.
- The USB and X-band are used for the transmission of observed data to allow reception by existing foreign stations.
- A remodulation type has been adopted for DCS/SAR relay in consideration of future on-board data processing.
- Mutual interference between many frequencies are minimized.

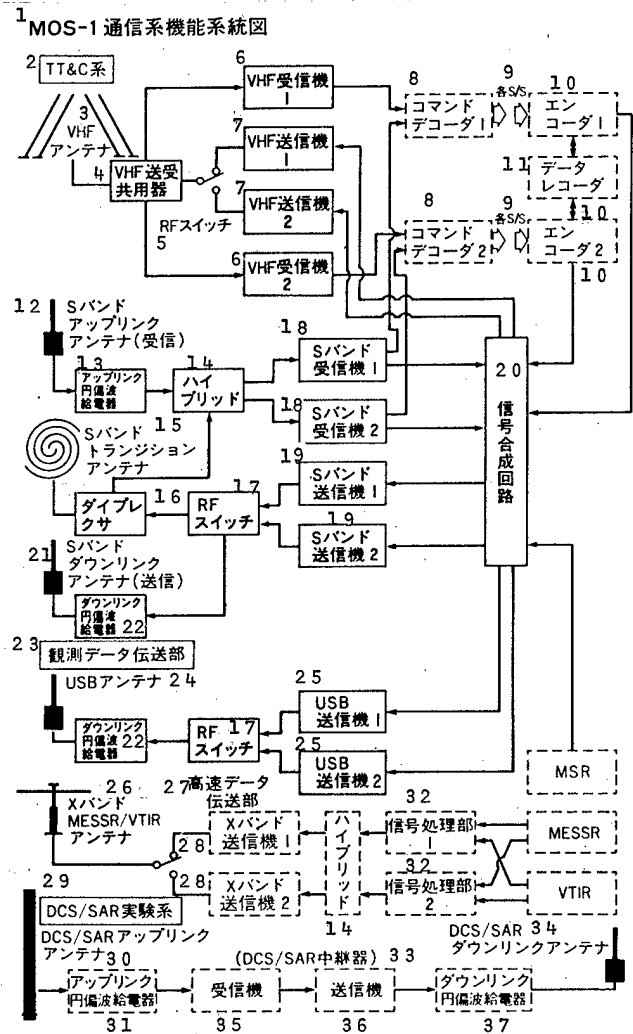

[key on next page]

Key: [to page 34 diagram]

1. MOS-1 communication system function chart
2. TT&C system
3. VHF antenna
4. Shared equipment for VHF transmitter and receiver
5. RF switch
6. VHF receiver
7. VHF transmitter
8. Command decoder
9. Each S/S
10. Encoder
11. Data recorder
12. S-band up-link antenna (for reception)
13. Up-link, circularly polarized wave feeder
14. Hybrid
15. S-band transition antenna
16. Diplexer
17. RF switch
18. S-band receiver
19. S-band transmitter
20. Signal synthesizing circuit
21. S-band down-link antenna (for transmission)
22. Down-link, circularly polarized wave feeder
23. Observation data transmission section
24. USB antenna
25. USB transmitter
26. X-band MESSR/VTIR antenna
27. High speed data transmission section
28. X-band transmitter
29. DCS/SAR experimental system
30. DCS/SAR up-link antenna
31. Up-link, circularly polarized wave feeder
32. Signal processing section
33. DCS/SAR relay
34. DCS/SAR down-link antenna
35. Receiver
36. Transmitter
37. Down-link, circularly polarized wave feeder

Major Data for the Antenna System

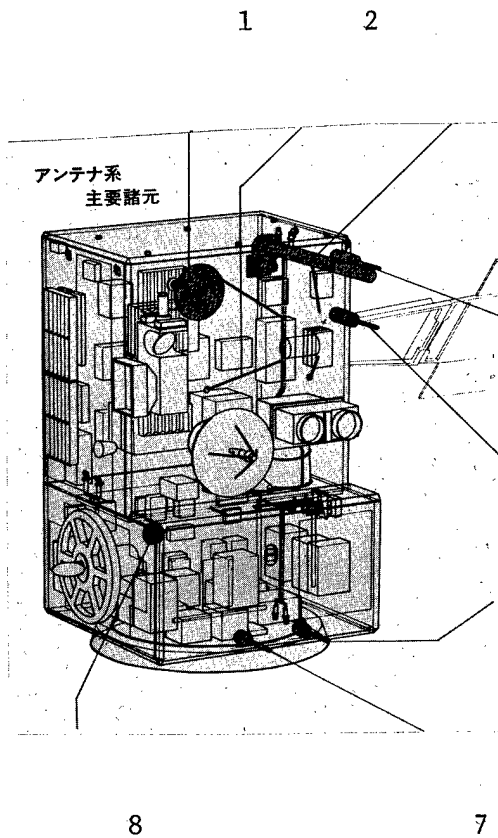

Key:

1. X-band antenna

Type Turnstyle  
 Frequency 8.4 GHz band  
 Polarization Right circularly polarized wave

4 2. VHF antenna

Type Monopole  
 Frequency 136 MHz band (down link)  
 148 MHz band (up link)  
 Polarization Right and left circularly polarized waves

6 3. UHF antenna for DCS/SAR up-link

Type Quadrifilar helical  
 Frequency 406 MHz band  
 Polarization Right circularly polarized wave

4. USB antenna

Type Quadrifilar helical  
 Frequency 2.2 GHz  
 Polarization Right circularly polarized wave

5. L-band antenna for DCS/SAR down-link

Type Quadrifilar helical  
 Frequency 1,543 MHz  
 Polarization Right circularly polarized wave

6. S-band down-link antenna

Type Quadrifilar helical  
 Frequency 1.7 GHz band  
 Polarization Right circularly polarized wave

7. S-band up-link antenna

Type Quadrifilar helical  
 Frequency 2.1 GHz band  
 Polarization Right circularly polarized wave

8. S-band transition antenna

Type Spiral  
 Frequency 1.7 GHz (down-link); 2.1 GHz (up-link)  
 Polarization Right circularly polarized wave

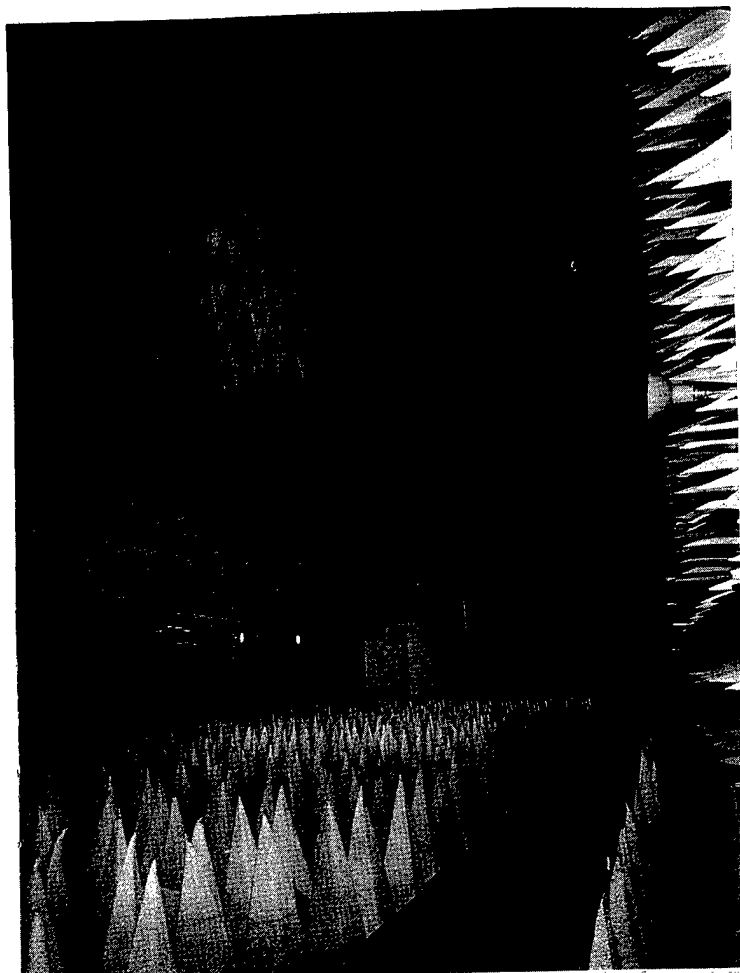

Radio wave dark room

USB transmitter

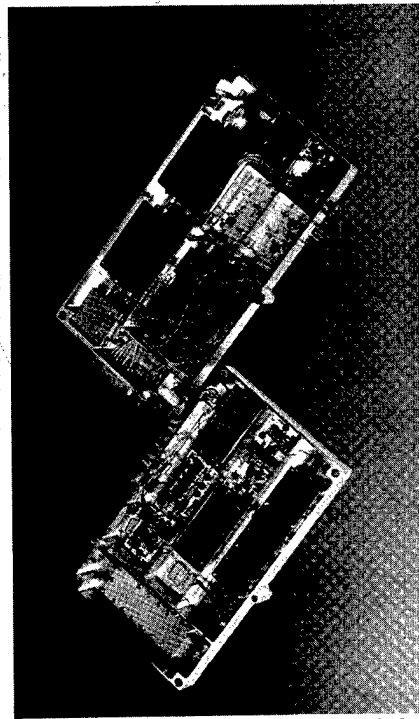

S-band receiver

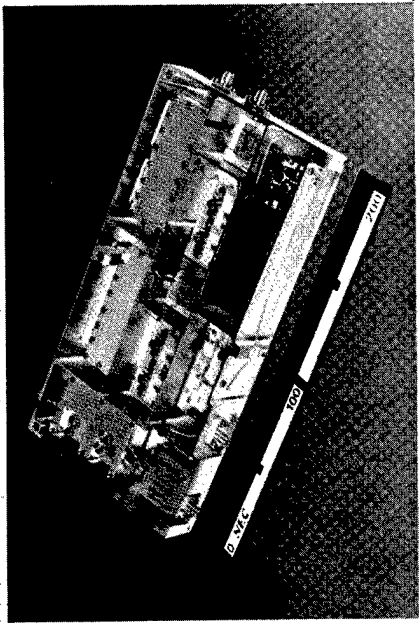

S-band transmitter, receiver and diplexer

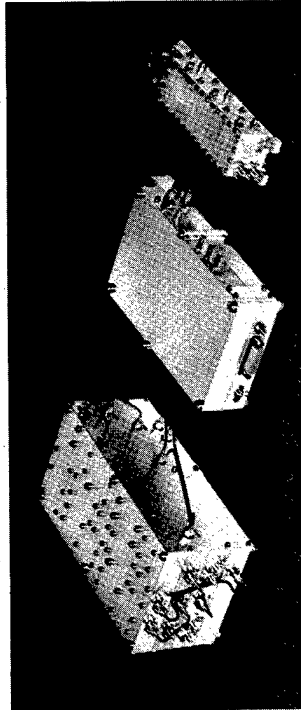

Quadrifilar helical antenna

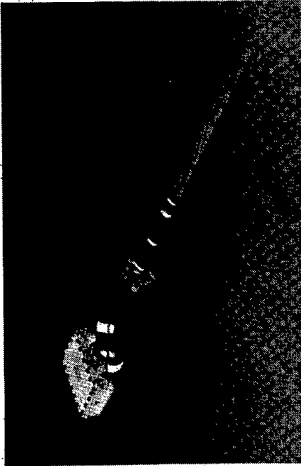

Data for Communication System

TT&C system

Telemetry

	VHF	S-band	USB
Modulation method	PCM-PM	PCM-FM-PM PCM-PM*	PCM-FM-PM
Carrier wave frequency	136.11 MHz	1705.0 MHz	2280.0 MHz
Modulation index	1.0 radian	0.35 radian 0.7 radian	0.5 radian
Transmission output	1.0 W	0.3 W	0.1 W
Bit rate	1,024 bps (real time), 26.624k bps (replay)		
Code type	Split phase level		
Subcarrier frequency	87.5 KHz		
Command	*(replay)		

	VHF	S-band
Modulation method	PCM-FSK/AM-PM	PCM-FSK/AM-PM
Carrier wave frequency	148.27 MHz	2115.6 MHz
Modulation index	0.9 radian	0.4 radian
Noise index	8.0 dB	3.0 dB
Bit rate	128 bps	
FSK frequency	"1" 8600 Hz, "0" 7400 Hz	
AM Modulation index	50 percent	

Ranging

	Up-link	Down-link
R&RR method	PN code ranging tone (distance) Two-way doppler (rate of change in distance) Simultaneous measurement from two different stations is possible	
Modulation method	PRN-PSK-PM	PRN-PSK-PM-PM
Carrier wave frequency	2115.6 MHz, 2117.8MHz	1705.0 MHz
Modulation index	1.0 radian	0.35 radian/CH
Subcarrier frequency	--	1.4 MHz, 3.6 MHz
PN code bit rate	125 kbps	
PSK frequency	500 KHz	

Observation data transmission system

MSR/MESSR/VTIR

	USB(MSR)	X-band (MESSR/VTIR)
Modulation method	PCM-PM	PCM-MSK
Carrier wave frequency	2286.0 MHz	8400 MHz
Modulation index	0.7 radian	--
Transmission output	0.1 W	4.0 W
Bit rate	2000 bps	8.78M bps
Code type	BIφ-L serial	NRZ-M

[continued]

DCS/SAR experiment system

DCS/SAR relay

	Up-link	Down-link
Relay method	Remodulation type	
Modulation method	PCM-PM	PCM-PM-PM
Carrier wave frequency	406.0 MHz	1543.0 MHz
Modulation index	1.2 radian	1.0 radian
Subcarrier frequency	--	200 KHz
Bit rate	128 bps	
Code type	Biphase level	

## Telemetry/Command System

The telemetry/command system consists of a telemetry encoder, a remote telemetry unit, a command decoder, and a data recorder. We used the same methods as those used on EST-III as much as possible. The data recorder is on board in order to receive telemetry data [collected] in invisible regions. For commands, we use discrete magnitude and stored commands. It is possible to operate the satellite through a single station in Japan.

Major functions of the telemetry and command system are listed below.

- Functions of the telemetry system
- Telemetry signals are encoded and transmitted through the S-band, USB, or VHF band.
- To monitor the operation of the satellite in the regions which cannot be observed [from Japan] directly, telemetry signals are stored in a data recorder, and then they are replayed at high speed when the satellite is visible from the ground station.
- Functions of the command system
- Switching and control of satellite operations are carried out by receiving command signals through the S-band and VHF band.
- The command operations can provide real time control and delayed control through timers.

### Major data for telemetry/encoder system

#### Data format

1 minor frame	128 words (per second)
1 major frame	8 minor frames
1 word length	8 bits
Frame cycle	24 bits
Bit rate	1,024 bps

#### Input

Analog input	279 CH 0-5 V {254 CH (1/8), 25 CH (1/1)}
Serial digital input	30 CH {2 CH (1/8), 28 CH (1/1)} "1" 5 V, "0" 0V
Bilevel digital input	165 CH "1" 5 V "0" 0V

### Major data for the data recorder

Data input channel	1 channel (2 tracks)
Recording time	105 minutes Min [minimum?] (105 minutes/2/track)
Replay time	4 minutes Min (2 minutes/track)
Replay/record ratio	26/1
Recording data	1,024 bps Bi $\phi$ -L
Replaying data	26,624 bps Bi $\phi$ -L

Major data for the command system

Bit rate 1 channel (2 track)  
 Command format Type I Discrete commands  
 Type II Discrete commands (without verification)  
 Type III Magnitude commands  
 Type IV Magnitude commands (without verification)  
 Type V Stored commands

Word configuration  
 Command word length 8 bits  
 Magnitude word length 14 bits  
 Synchronous word length 19 bits  
 Satellite address 7 bits

Real time commands  
 Discrete commands 254 (MAX) <All "0", excluding "1" code>  
 Magnitude commands 32 (MAX)

Stored commands  
 Discrete commands 16 (MAX)  
 Maximum delay time in command execution 18.2 hours

1 テレメトリ/コマンド系サブシステム系統図

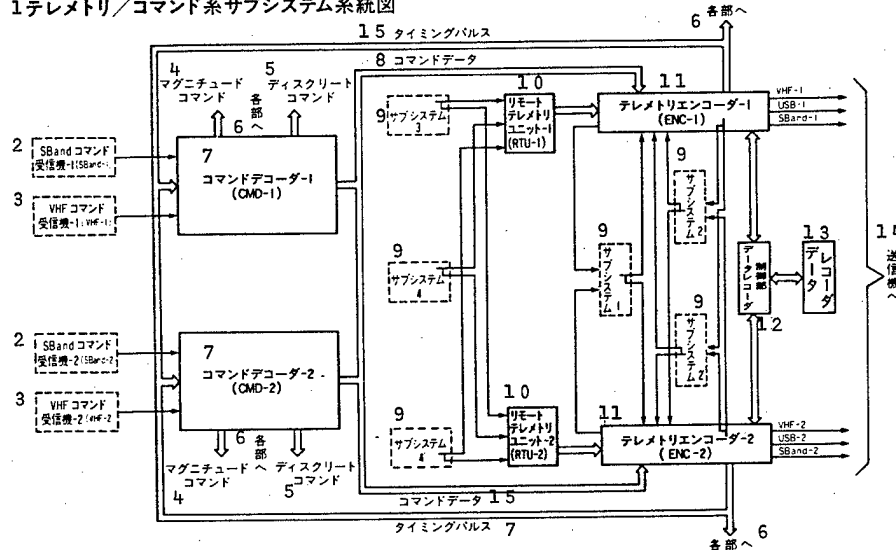

Key:

- |  |                                   |
|--|-----------------------------------|
| 1. Telemetry/command system subsystems chart | 8. Command data                   |
| 2. S-band command receiver                   | 9. Subsystem                      |
| 3. VHF command receiver                      | 10. Remote telemetry unit         |
| 4. Magnitude command                         | 11. Telemetry encoder             |
| 5. Discrete command                          | 12. Data recorder control section |
| 6. To various sections                       | 13. Data recorder                 |
| 7. Command decoder                           | 14. To transmitter                |
|  | 15. Timing pulse                  |

## Gas Jet System

The gas jet system consists of two propellant tanks, six thrusters, four filling and draining valves, two filters, four shutoff valves, and piping. This system performs the following functions.

- Orbital correction to achieve solar synchronous orbit after the satellite has been inserted into its initial orbit.
- Maintenance of the solar synchronous orbit during the mission period.

In order to facilitate the installation and integration of the gas jet system to the satellite, major equipment in the system has been concentrated on the bus equipment side and has been formed into modular subsystems. Also, to minimize shifting of the center of gravity as the propellant is spent, the fuel tank is installed over the center of gravity. The thrusters are arranged to remove plume impingement and sensor contamination. Furthermore, to avoid external disturbance to the satellite's attitude, the thrust axis of each thruster passes through the center of gravity of the satellite.

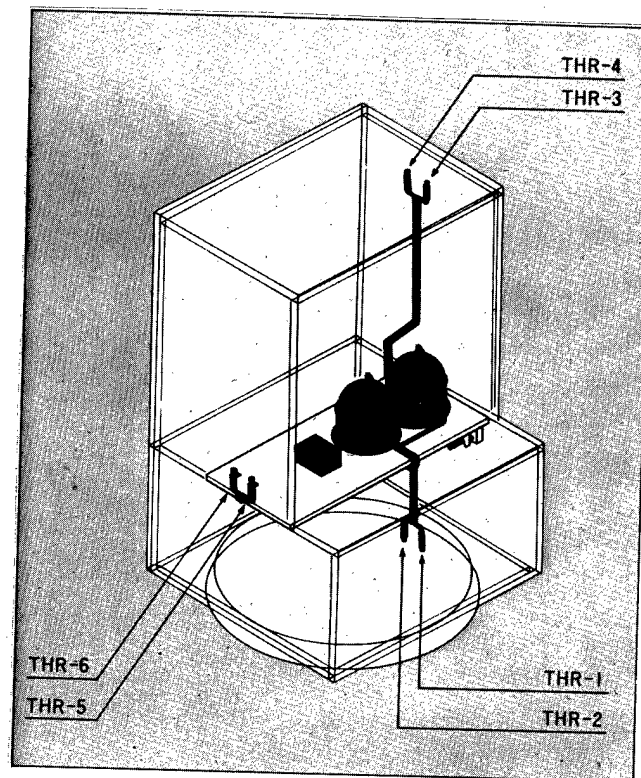

Major data for the gas jet system

Orbit control

Control inside the orbital plane

± roll direction 2N

THR - (1,2);(3,4)

Control outside the orbital plane

- pitch direction 2N

THR - (5,6)

Propellant tanks

Type

Titanium alloy, spherical, all welded,  
contains bladder, polar mount type

Capacity

9.8 kg

Number

Two tanks

Thruster

Type

IN thruster, unit coupled with propellant

Catalysis

Shell 405

Number

Six units

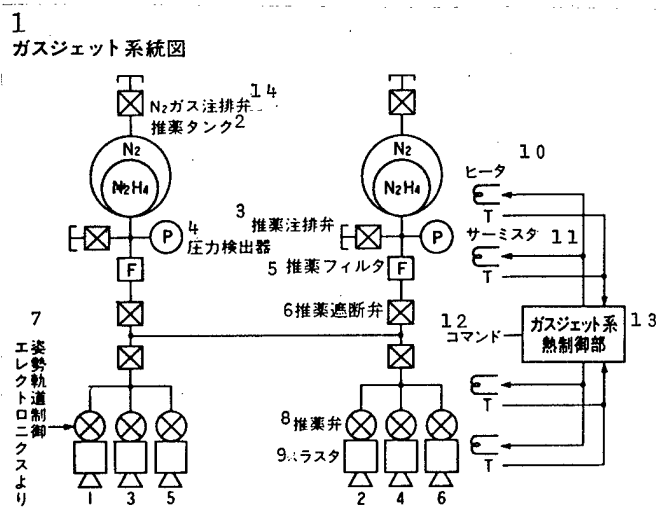

Key:

- |  |   |
|--|---|
| 1. Gas jet system chart                                      | 8. Propellant valves                              |
| 2. Propellant tank   | 9. Thrusters                                      |
| 3. Propellant filling and draining valve                     | 10. Heater  |
| 4. Pressure detector   | 11. Thermister                                    |
| 5. Propellant filter valve                                   | 12. Command                                       |
| 6. Propellant shutoff valve                                  | 13. Gas jet system heat control section           |
| 7. Attitude orbit control signals from electronic [circuits] | 14. N <sub>2</sub> gas filling and draining valve |

N<sub>2</sub> gas filling and  
draining valve

N<sub>2</sub>H<sub>4</sub> propellant filling and  
draining valve

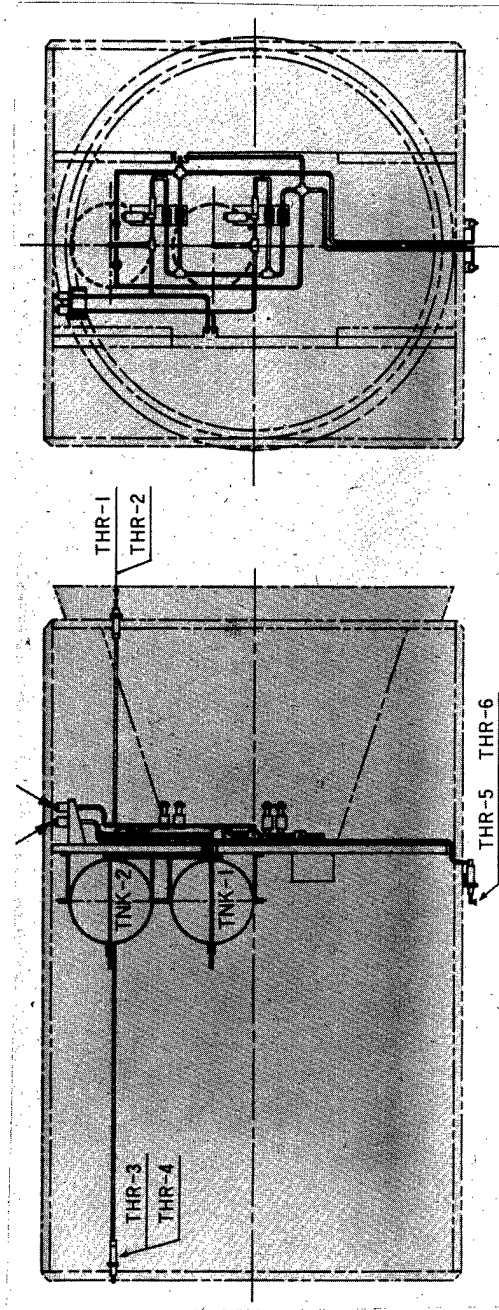

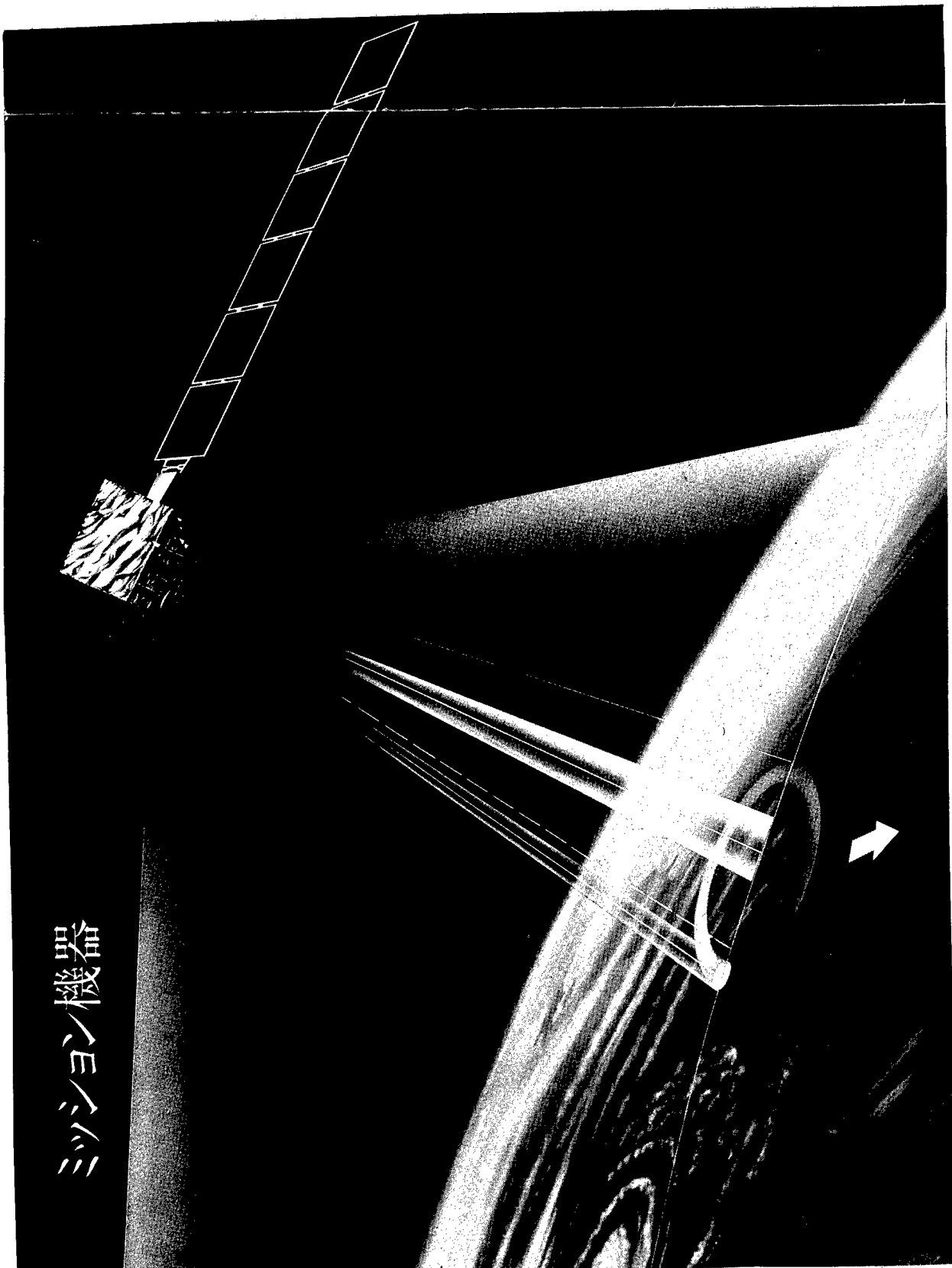



Data for VTIR

Scanning method	Mechanical rotation scanning method
Instantaneous field of vision	1 m rad (Visible [wavelength]) 3 m rad (Thermal [infrared wavelength])
Scanning width	1,500 km
Scanning time	0.137 sec (one rotation)
Observation wavelength ( $\mu\text{m}$ )	0.5-0.7 6.0-7.0 10.5-11.5 11.5-12.5

• Microwave radiometer

The microwave radiometer (MSR) maps images of land and sea with microwave band to acquire data on the amount of water vapor on the ocean surface and in the atmosphere, the amount of water, and sea ice. MSR uses two microwave bands for this purpose, and rotates an antenna by the mechanical rotation scanning method.

Data for the microwave radiometer

Scanning method	Mechanical rotation scanning method
Beam width	2.4° Lower than [the indicated angles] (23 GHz) 1.8° Lower than [the indicated angles] (31 GHz)
Scanning width	320 km
Scanning time	3.2 sec (one rotation)
Observation frequency	23.8 GHz 31.4 GHz
Temperature resolution	1°K (23 GHz) 3°K (31 GHz) (Estimated values)

• DCS/SAR relay

The DCS/SAR relay receives UHF band signals from a ground station and reemits them in the L band. Basic experiments, such as determining the location of an object on the ground using the Doppler effect, are carried out using this relay.

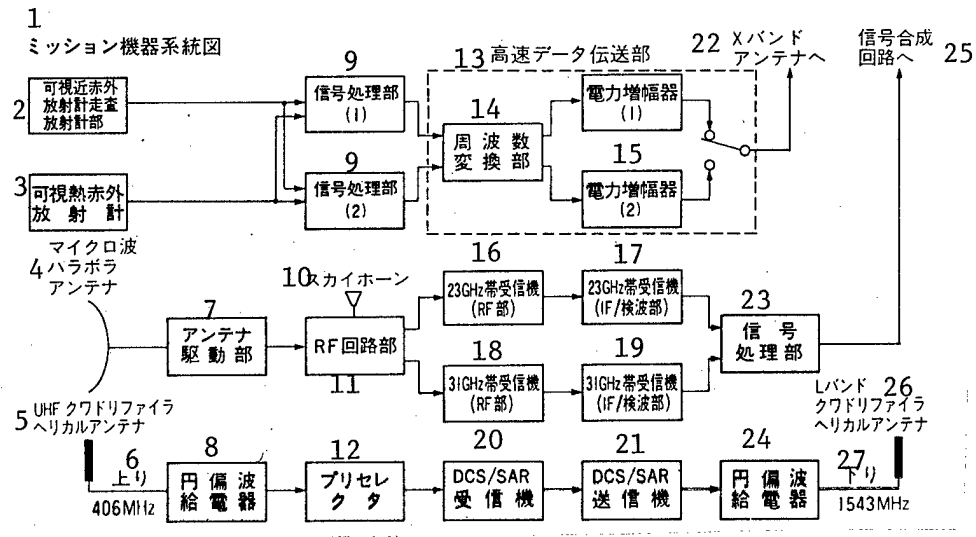

Key:

1. Mission equipment charge
2. Visible near-infrared radiometer scanning radiometer section
3. Visible thermal infrared radiometer
4. Microwave parabola antenna
5. UHF quadrifilar helical antenna
6. Up[-link]
7. Antenna driver section
8. Circularly polarized wave feeder
9. Signal processing section
10. Sky horn
11. RF circuit section
12. Preselector
13. High speed data transmission section
14. Frequency converter section
15. Power amplifiers
16. 23 GHz band receiver (RF section)
17. 23 GHz band receiver (IF/detector section)
18. 31 GHz band receiver (RF section)
19. 31 GHz band receiver (IF/detector section)
20. DCS/SAR receiver
21. DCS/SAR transmitter
22. To X-band antenna
23. Signal processing section
24. Circularly polarized wave feeder
25. To signal synthesizer circuit
26. L-band quadrifilar helical antenna
27. Down[-link]

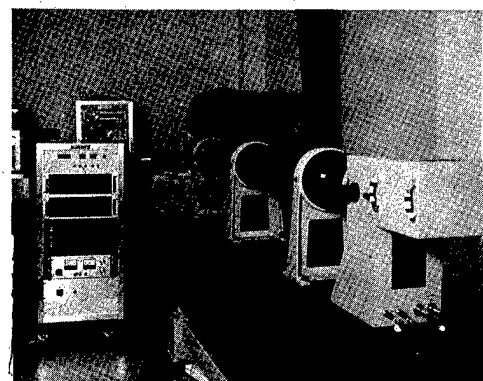
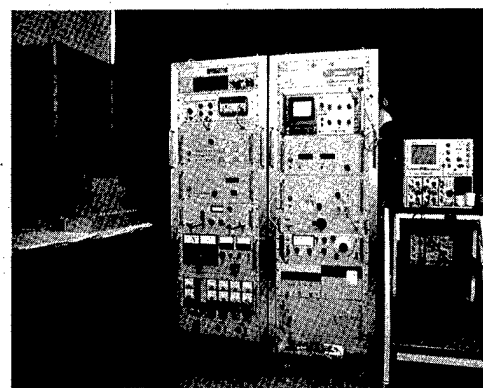
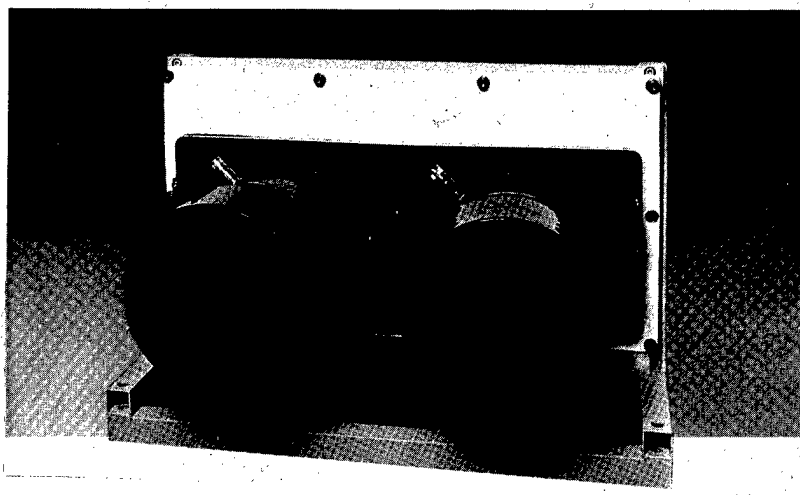
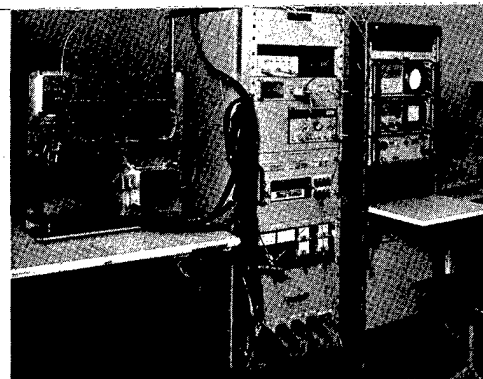
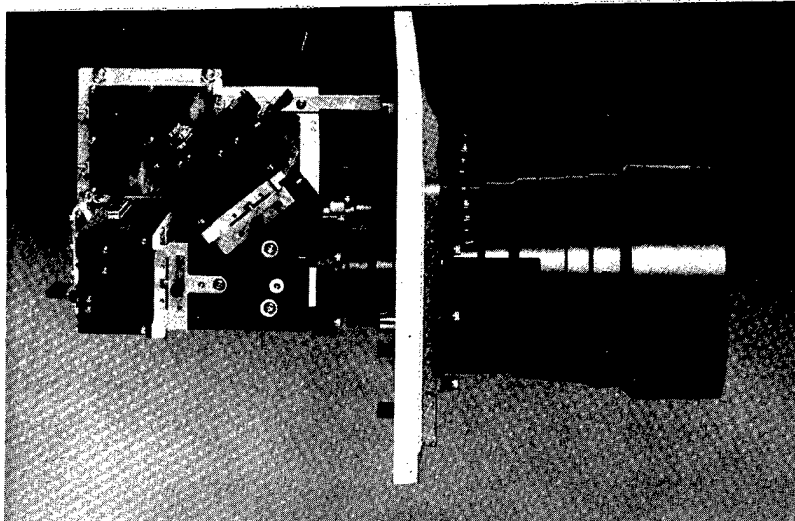

- Upper, lower left: MESSR scanning radiometer section  
Upper right: MESSR high speed data transmission section and the apparatus for performance evaluation  
Middle right: MESSR signal processing section and the apparatus for performance evaluation  
Lower right: Apparatus for a performance evaluation of the MESSR

## Launch/Operation

MOS-1 will be launched by the N-II launcher from the Tanegashima Space Center. When the satellite reaches an altitude of 913 km, its second stage points the attitude of the satellite for insertion into the planned orbit. The satellite will be separated from the launcher over South America, and it will be inserted into a solar synchronous, semi-recursive orbit. After damping the nutation, which may occur after separation, is confirmed, the solar cell paddle will be extended, the satellite's pitching axis will be arrested, the sun will be traced by the solar cell paddle, and then the satellite will begin to track the sun. Orbital insertion errors will be corrected by the gas jet system within a week. During launching and the initial stages, the Tsukuba Space Center will serve as the central tracking and control station. Tracking and control of the satellite will be carried out by the Masuda tracking and control station, which will serve as the main station, with the help of Katsuura, Okinawa, and a down-range station (in the Caroline Islands, on a ship, or in South America).

The attitude of a satellite in orbit is disturbed by solar radiation pressure, gravitational inclination, and residual magnetism. Maintenance of the attitude against external disturbances and unleading are all processed on board without interference from the ground stations. The external disturbances that affect the satellite's orbit are the gravitational forces of the moon and the sun, solar radiation pressure, and atmospheric resistance. The altitude is maintained within  $\pm 390\text{m}$ , and orbital corrections are carried out approximately every 300 days.

In stationary stages, housekeeping and stationkeeping are carried out by the Tsukuba Space Center through Masuda and Katsuura tracking stations and the Okinawa tracking and control station, which will serve as the main tracking station. Housekeeping data, which are collected during the time zones that cannot be observed directly from the Japanese stations, are recorded on the data recorder and then replayed in the visible time zone. The operation of mission equipment is controlled by the Earth Observation Center. Observed and telemetry data will be provided to overseas data receiving stations by using stored commands.

### An example of the launch sequence

Elapsed time (seconds)	Events
0	Lift-off
282 (4 minutes 42 seconds)	Separation of the first and second stage
288 (4 minutes 48 seconds)	The first ignition of the second stage engine
297 (4 minutes 57 seconds)	Fairing separation
679 (11 minutes 19 seconds)	The first burning of the second stage engine completed (SECO 1)
3412 (56 minutes 52 seconds)	The second ignition of the second stage engine
3421 (57 minutes 1 second)	The second burning of the second stage engine stopped (SECO 2)
3481 (58 minutes 1 second)	Satellite separation
3577 (59 minutes 37 seconds)	Start extending the solar cell paddle
3697 (61 minutes 37 seconds)	Arrest pitching
5137 (85 minutes 37 seconds)	Start rotating the solar cell paddle
5737 (95 minutes 37 seconds)	Start corrections for the solar cell paddle
6037 (100 minutes 37 seconds)	Complete corrections for the solar cell paddle

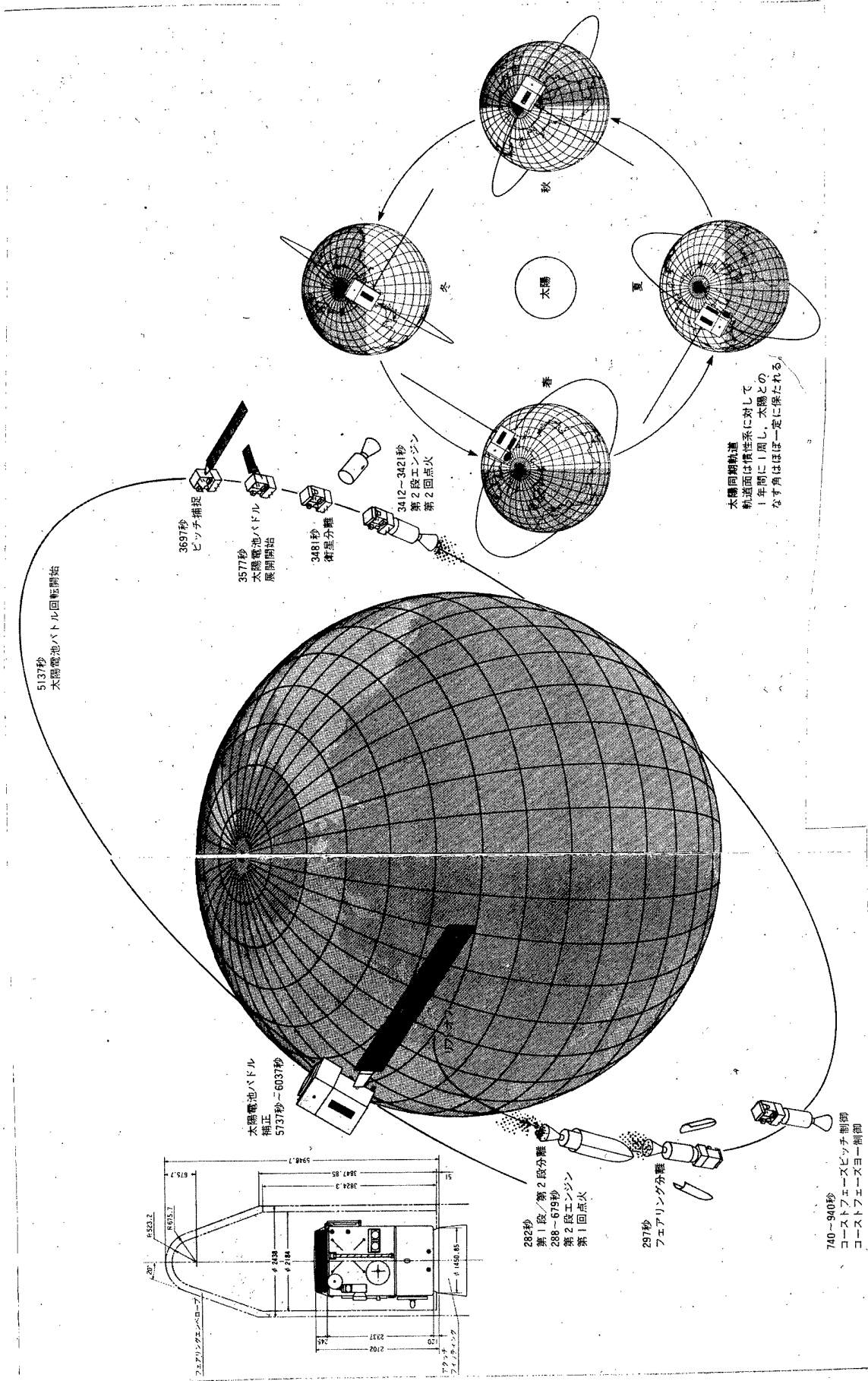

Key: [to page 52 figures]

[Figure in upper left corner]

1. Fairing envelope
2. Attach fitting

[Large globe figure in center--  
starting in center of globe and moving  
counterclockwise with line]

1. Lift-off
2. 282 seconds; the first and second stage separate; 288-679 seconds; the second stage engine is ignited for the first time
3. 297 seconds; fairing separates
4. 740-940 seconds; control pitching during the coast phase; control yawing during the coast phase
5. 3412-3421 seconds; the second stage engine is ignited for the second time
6. 3481 seconds; the satellite separates
7. 3577 seconds; extension of the solar cell paddle starts
8. 3697 seconds; pitching is arrested
9. 5137 seconds; the solar cell paddle begins to rotate
10. 5737-6037 seconds; corrections for the solar cell paddle are applied

[Global system on right]

Solar synchronous orbit; the orbital plane rotates once a year with respect to an inertial system, and the angle between the sun and the orbital plane is kept almost constant.

[center circle]	The sun
[north globe]	Winter
[east globe]	Fall
[south globe]	Summer
[west globe]	Spring

1 MOS-1 システム運用モード表

2 サブシステム	3 モード	4 打上げモード	5 初期捕捉モード	7 不可視モード	6 軌道上モード										
					8 日照モード						9 日陰モード				
					MESSR + VTIR + MSR	MESSR + VTIR	MESSR + MSR	VTIR + MSR	MESSR	VTIR	MSR	VTIR	MSR		
10 ミッション機器	可視近赤外放射計(MESSR)	11				●	●	●		●					
	可視熱赤外放射計(VTIR)	12				●	●		●			●			
	マイクロ波放射計(MSR)	13				●		●				●		●	
	DCS/SAR 中継器	14			●	●	●	●	●	●	●	●	●	●	
15 バス機器	通信系/アンテナ系	16													
	VHF 送信機	17	●	●											
	VHF 受信機   UHF アンテナ	18	●	●	●	●	●	●	●	●	●	●	●	●	
	Sバンド送信機   Sバンドダウンリンクアンテナ	19	●	●	●	●	●	●	●	●	●	●	●	●	
	Sバンド受信機   Sバンドアップリンクアンテナ	20	●	●	●	●	●	●	●	●	●	●	●	●	
	Sバンドトランジションアンテナ	21	●*	●*	●	●	●	●	●	●	●	●	●	●	
	USB 送信機   USB アンテナ	22			●	●	●	●	●	●	●	●	●	●	
	太陽電池パドル系	23		●	●	●	●	●	●	●	●	●	●	●	●
	ガス ジェット系	24		●											
	姿勢軌道制御系   テレメトリ/コマンド系   電源系   熱制御系	25	●	●	●	●	●	●	●	●	●	●	●	●	●
						軌道補正のため1年に数回使用 26									

●: 使用するサブシステムあるいは機器 27  
 \*: 送・受信用(他は受信用として用いる) 28

Key:

1. Table of system operating modes for MOS-1
2. Subsystem
3. Mode
4. Launch mode
5. Early arrest mode
6. In-orbit mode
7. Invisible mode
8. In-the-sun mode
9. In-the-shade mode
10. Mission equipment
11. Visible near-infrared radiometer (MESSR)
12. Visible thermal infrared radiometer (VTIR)
13. Microwave radiometer (MSR)
14. DCS/SAR relay
15. Bus equipment
16. Communication and antenna systems
17. VHF transmitter
18. VHF receiver; UHF antenna
19. S-band transmitter; S-band down-link antenna
20. S-band receiver; S-band up-link antenna
21. S-band transition antenna
22. USB transmitter; USB antenna
23. Solar cell paddle system
24. Gas jet system
25. Attitude orbit control system; telemetry/command system; power supply system; thermal control system
26. Used several times a year to correct the orbit
27. ●: Subsystem or equipment used
28. \*: For both transmitting and receiving (others are for receiving only)

1 世界の人工衛星における NEC の実績

2 ●国内

3	試験衛星	我が国初の人工衛星 L-4S-5 おおすみ	MS-T1 たんせい1号		MS-T2 たんせい2号	JETS-I きく	
4	科学衛星		我が国初の科学衛星 MS-F2 しんせい	REXS でんぱ		SRATS たいよう	CORSA (打上げ失敗)
5	実用衛星						ISS うめ

8 10 11 12 15 17

32-34

37 38

39 40

32 41

29 ●海外 (NEC 参加分のみ)

4	科学衛星		火星探査 マリナ8号 マリナ9号 (打上げ失敗)	木星探査 パイオニア10号	木星、土星探査 パイオニア11号		火星探査 パイキングA/B
5	実用衛星						
30	気象衛星						
31	通信衛星		初の本格的 商用通信衛星 インテルサット IV F2		F7	F8	インテルサット WA F1 F2 F6 (打上げ失敗) マリサット F1 F2 F3

35 36 16 42 43

## Key:

1. Worldwide achievements of NEC in artificial satellites
2. Domestic
3. Experimental satellites
4. Scientific satellites
5. Satellites for practical applications
6. First artificial satellite of Japan
7. Osumi
8. (Launch failed)
9. Tansei No 1
10. First Japanese scientific satellite
11. Shinsei
12. Dempa
13. Tansei No 2

14. Kiku
15. Taiyo
16. (Launch failed)
17. Ume
18. Kiku No 2
19. Tansei No 3
20. Himawari
21. Sakura
22. Kyokko
23. Jikiken
24. Yuri
25. Ume No 2
26. Ayame (launch failed)
27. Hakucho
28. Momentum wheel installed onboard
29. Overseas (only those in which NEC participated)

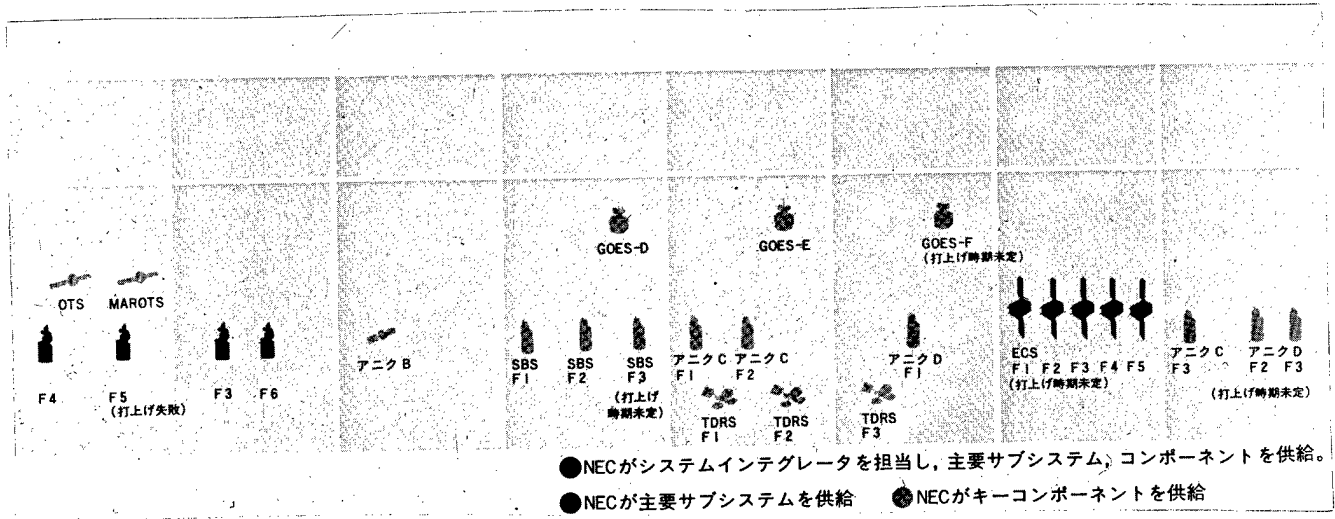
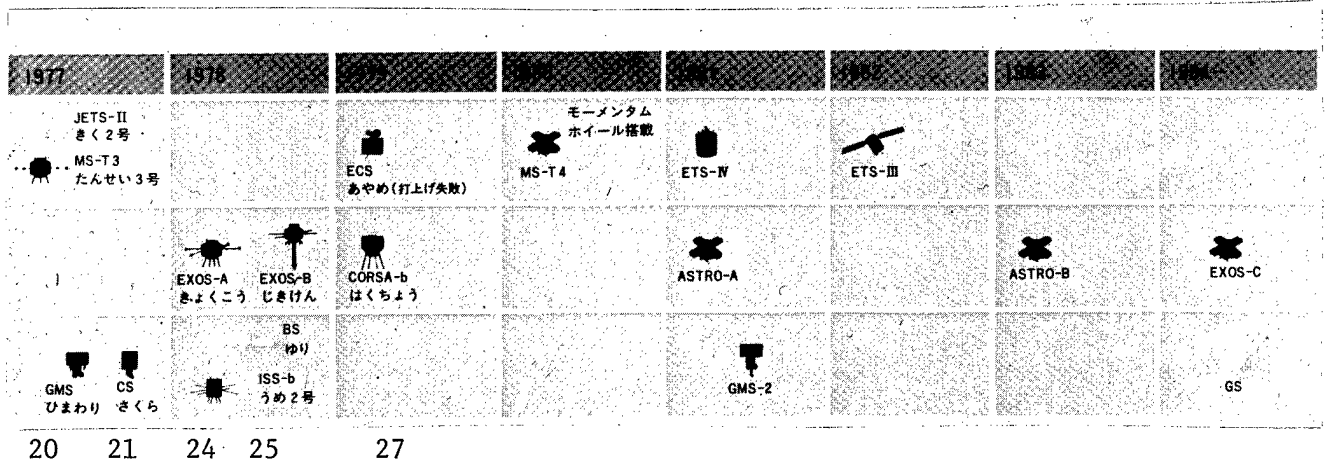

● NECがシステムインテグレータを担当し、主要サブシステム、コンポーネントを供給。  
 ● NECが主要サブシステムを供給 ● NECがキーコンポーネントを供給

- 30. Meteorological satellites
- 31. Communications satellites
- 32. Mars exploration
- 33. Mariner No 8 (launch failed)
- 34. Mariner No 9
- 35. First full-scale commercial communications satellite
- 36. Intelsat IV
- 37. Jupiter exploration
- 38. Pioneer No 10
- 39. Jupiter and Saturn exploration

- 40. Pioneer No 11
- 41. Viking A/B
- 42. Intelsat IV A
- 43. Marisat
- 44. Anik
- 45. (Launch date undecided)

- NEC took the role of a system integrator, and provided major subsystems and components
- NEC supplied major subsystems
- NEC provided key components

1 2 3 4 5 6 7 8 9 10 11 12 13 14 15 16 17

5574  
 5575  
 5576  
 5577  
 5578  
 5579  
 5580  
 5581  
 5582  
 5583  
 5584  
 5585  
 5586  
 5587  
 5588  
 5589  
 5590  
 5591  
 5592  
 5593  
 5594  
 5595  
 5596  
 5597  
 5598  
 5599  
 5600  
 5601  
 5602  
 5603  
 5604  
 5605  
 5606  
 5607  
 5608  
 5609  
 5610  
 5611  
 5612  
 5613  
 5614  
 5615  
 5616  
 5617  
 5618  
 5619  
 5620  
 5621  
 5622  
 5623  
 5624  
 5625  
 5626  
 5627  
 5628  
 5629  
 5630  
 5631  
 5632  
 5633  
 5634  
 5635  
 5636  
 5637  
 5638  
 5639  
 5640  
 5641  
 5642  
 5643  
 5644  
 5645  
 5646  
 5647  
 5648  
 5649  
 5650  
 5651  
 5652  
 5653  
 5654  
 5655  
 5656  
 5657  
 5658  
 5659  
 5660  
 5661  
 5662  
 5663  
 5664  
 5665  
 5666  
 5667  
 5668  
 5669  
 5670  
 5671  
 5672  
 5673  
 5674  
 5675  
 5676  
 5677  
 5678  
 5679  
 5680  
 5681  
 5682  
 5683  
 5684  
 5685  
 5686  
 5687  
 5688  
 5689  
 5690  
 5691  
 5692  
 5693  
 5694  
 5695  
 5696  
 5697  
 5698  
 5699  
 5700  
 5701  
 5702  
 5703  
 5704  
 5705  
 5706  
 5707  
 5708  
 5709  
 5710  
 5711  
 5712  
 5713  
 5714  
 5715  
 5716  
 5717  
 5718  
 5719  
 5720  
 5721  
 5722  
 5723  
 5724  
 5725  
 5726  
 5727  
 5728  
 5729  
 5730  
 5731  
 5732  
 5733  
 5734  
 5735  
 5736  
 5737  
 5738  
 5739  
 5740  
 5741  
 5742  
 5743  
 5744  
 5745  
 5746  
 5747  
 5748  
 5749  
 5750  
 5751  
 5752  
 5753  
 5754  
 5755  
 5756  
 5757  
 5758  
 5759  
 5760  
 5761  
 5762  
 5763  
 5764  
 5765  
 5766  
 5767  
 5768  
 5769  
 5770  
 5771  
 5772  
 5773  
 5774  
 5775  
 5776  
 5777  
 5778  
 5779  
 5780  
 5781  
 5782  
 5783  
 5784  
 5785  
 5786  
 5787  
 5788  
 5789  
 5790  
 5791  
 5792  
 5793  
 5794  
 5795  
 5796  
 5797  
 5798  
 5799  
 5800  
 5801  
 5802  
 5803  
 5804  
 5805  
 5806  
 5807  
 5808  
 5809  
 5810  
 5811  
 5812  
 5813  
 5814  
 5815  
 5816  
 5817  
 5818  
 5819  
 5820  
 5821  
 5822  
 5823  
 5824  
 5825  
 5826  
 5827  
 5828  
 5829  
 5830  
 5831  
 5832  
 5833  
 5834  
 5835  
 5836  
 5837  
 5838  
 5839  
 5840  
 5841  
 5842  
 5843  
 5844  
 5845  
 5846  
 5847  
 5848  
 5849  
 5850  
 5851  
 5852  
 5853  
 5854  
 5855  
 5856  
 5857  
 5858  
 5859  
 5860  
 5861  
 5862  
 5863  
 5864  
 5865  
 5866  
 5867  
 5868  
 5869  
 5870  
 5871  
 5872  
 5873  
 5874  
 5875  
 5876  
 5877  
 5878  
 5879  
 5880  
 5881  
 5882  
 5883  
 5884  
 5885  
 5886  
 5887  
 5888  
 5889  
 5890  
 5891  
 5892  
 5893  
 5894  
 5895  
 5896  
 5897  
 5898  
 5899  
 5900  
 5901  
 5902  
 5903  
 5904  
 5905  
 5906  
 5907  
 5908  
 5909  
 5910  
 5911  
 5912  
 5913  
 5914  
 5915  
 5916  
 5917  
 5918  
 5919  
 5920  
 5921  
 5922  
 5923  
 5924  
 5925  
 5926  
 5927  
 5928  
 5929  
 5930  
 5931  
 5932  
 5933  
 5934  
 5935  
 5936  
 5937  
 5938  
 5939  
 5940  
 5941  
 5942  
 5943  
 5944  
 5945  
 5946  
 5947  
 5948  
 5949  
 5950  
 5951  
 5952  
 5953  
 5954  
 5955  
 5956  
 5957  
 5958  
 5959  
 5960  
 5961  
 5962  
 5963  
 5964  
 5965  
 5966  
 5967  
 5968  
 5969  
 5970  
 5971  
 5972  
 5973  
 5974  
 5975  
 5976  
 5977  
 5978  
 5979  
 5980  
 5981  
 5982  
 5983  
 5984  
 5985  
 5986  
 5987  
 5988  
 5989  
 5990  
 5991  
 5992  
 5993  
 5994  
 5995  
 5996  
 5997  
 5998  
 5999  
 6000

	1	2	3	4	5	6	7	8	9	10	11	12	13	14	15	16	17
システム技術	プロ	グ	ラ	ム	管	理											
	シ	ス	テ	ム	設	計											
	システムインテグレーション試験																
共通サブシステム技術	インテグレーションハードウェア																
	構造系ハードウェア																
	熱制御系ハードウェア																
	通信系ハードウェア																
	電源系ハードウェア																
	姿勢軌道制御系ハードウェア																
	オンボードプロセッサ																
ミッション系ハードウェア	ミッション系ハードウェア																
通信/データ処理系ハードウェア	通信/データ処理系ハードウェア																
支援技術	地上支援装置																
	地上施設/設備																
	打上げ支援作業																
	運用支援作業																
	解析/評価作業																

○：自主 △：外国と協力

1.8 1.9 2.0 2.1 2.2 2.3 2.4 2.5 2.6 2.7 2.8 2.9 3.0 3.1 3.2 3.3 3.4 3.5 3.6 3.7 3.8

39 40

Key:

- |     |                       |     |   |
|-----|-----------------------|-----|---|
| 1.  | Osumi                 | 21. | System integration testing                    |
| 2.  | Tansei                | 22. | Common subsystems engineering                 |
| 3.  | Intelsat IV F2, F6-Fi | 23. | Integration hardware                          |
| 4.  | Shinsei               | 24. | Airframe system hardware                      |
| 5.  | Dempa                 | 25. | Thermal control system hardware               |
| 6.  | Tansei No 2           | 26. | Communications system hardware                |
| 7.  | Taiyo                 | 27. | Power supply system hardware                  |
| 8.  | Kiku                  | 28. | Attitude orbit control system hardware        |
| 9.  | Ume                   | 29. | Onboard processor                             |
| 10. | Tansei No 3           | 30. | Mission system subsystem engineering          |
| 11. | Himawari              | 31. | Mission system hardware                       |
| 12. | Sakura                | 32. | Communication/data processing system hardware |
| 13. | Kyokko                | 33. | Support engineering                           |
| 14. | Ume No 2              | 34. | Ground support apparatus                      |
| 15. | Jikiken               | 35. | Ground facilities/installations               |
| 16. | Hakucho               | 36. | Launch support operations                     |
| 17. | Ayame                 | 37. | Operation support tasks                       |
| 18. | Systems engineering   | 38. | Analysis/evaluation operations                |
| 19. | Program management    | 39. | By ourselves                                  |
| 20. | System design         | 40. | In cooperation with foreign firms             |

[Back cover]

NEC: Nippon Electric Company, Ltd.

Main office

33-1 Shiba 5-chome, Minato-ku, Tokyo, (Headquarters building of NEC)

Telephone: Tokyo (03) 454-1111 (key number) Postal code: 108

Space Development Project, Yokohama Establishment

4035 Ikebe-cho, Midori-ku, Yokohama, Kanagawa Prefecture

Telephone: Yokohama (045) 932-1111 (key number) Postal code: 226

October 1979

9829

CSO: 8129/0238

- END -