

332130

JPRS 84527

13 October 1983

19981013 082

USSR Report

LIFE SCIENCES

EFFECTS OF NONIONIZING ELECTROMAGNETIC RADIATION

No. 12

DISTRIBUTION STATEMENT A

Approved for public release
Distribution Unlimited

DTIC QUALITY INSPECTED 4

FBIS

FOREIGN BROADCAST INFORMATION SERVICE

REPRODUCED BY
NATIONAL TECHNICAL
INFORMATION SERVICE
U.S. DEPARTMENT OF COMMERCE
SPRINGFIELD, VA. 22161

5
27
A03

NOTE

JPRS publications contain information primarily from foreign newspapers, periodicals and books, but also from news agency transmissions and broadcasts. Materials from foreign-language sources are translated; those from English-language sources are transcribed or reprinted, with the original phrasing and other characteristics retained.

Headlines, editorial reports, and material enclosed in brackets [] are supplied by JPRS. Processing indicators such as [Text] or [Excerpt] in the first line of each item, or following the last line of a brief, indicate how the original information was processed. Where no processing indicator is given, the information was summarized or extracted.

Unfamiliar names rendered phonetically or transliterated are enclosed in parentheses. Words or names preceded by a question mark and enclosed in parentheses were not clear in the original but have been supplied as appropriate in context. Other unattributed parenthetical notes within the body of an item originate with the source. Times within items are as given by source.

The contents of this publication in no way represent the policies, views or attitudes of the U.S. Government.

PROCUREMENT OF PUBLICATIONS

JPRS publications may be ordered from the National Technical Information Service (NTIS), Springfield, Virginia 22161. In ordering, it is recommended that the JPRS number, title, date and author, if applicable, of publication be cited.

Current JPRS publications are announced in Government Reports Announcements issued semimonthly by the NTIS, and are listed in the Monthly Catalog of U.S. Government Publications issued by the Superintendent of Documents, U.S. Government Printing Office, Washington, D.C. 20402.

Correspondence pertaining to matters other than procurement may be addressed to Joint Publications Research Service, 1000 North Glebe Road, Arlington, Virginia 22201.

Soviet books and journal articles displaying a copyright notice are reproduced and sold by NTIS with permission of the copyright agency of the Soviet Union. Permission for further reproduction must be obtained from copyright owner.

JPRS REPORTS

Japan Report
Korean Affairs Report
Southeast Asia Report
Mongolia Report

Near East/South Asia Report
Sub-Saharan Africa Report
West Europe Report
West Europe Report: Science and Technology
Latin America Report

USSR

Political and Sociological Affairs
Problems of the Far East
Science and Technology Policy
Sociological Studies
Translations from KOMMUNIST
USA: Economics, Politics, Ideology
World Economy and International Relations
Agriculture
Construction and Related Industries
Consumer Goods and Domestic Trade
Economic Affairs
Energy
Human Resources
International Economic Relations
Transportation

Physics and Mathematics
Space
Space Biology and Aerospace Medicine
Military Affairs
Chemistry
Cybernetics, Computers and Automation Technology
Earth Sciences
Electronics and Electrical Engineering
Engineering and Equipment
Machine Tools and Metal-Working Equipment
Life Sciences: Biomedical and Behavioral Sciences
Life Sciences: Effects of Nonionizing Electromagnetic
Radiation
Materials Science and Metallurgy
Meteorology and Hydrology

EASTERN EUROPE

Political, Sociological and Military Affairs
Scientific Affairs

Economic and Industrial Affairs

CHINA

Political, Sociological and Military Affairs
Economic Affairs
Science and Technology

RED FLAG
Agriculture
Plant and Installation Data

WORLDWIDE

Telecommunications Policy; Research and
Development
Nuclear Development and Proliferation

Epidemiology

FBIS DAILY REPORT

China
Soviet Union
South Asia
Asia and Pacific

Eastern Europe
Western Europe
Latin America
Middle East and Africa

To order, see inside front cover

13 October 1983

USSR REPORT
LIFE SCIENCES
EFFECTS OF NONIONIZING ELECTROMAGNETIC RADIATION

No. 12

CONTENTS

Effect of a Constant Magnetic Field on Blood Clotting Indicators (IZVESTIYA AKADEMII NAUK LATVIYSKOY SSR, Jan 83).....	1
Use of a Permanent Magnetic Field to Treat Dystrophic Diseases of the Limbs (V. M. Lirtsman, et al.; SOVETSKAYA MEDITSINA, Oct 82).....	11
Effect of Electromagnetic Energy on Generative Function of Animals (A. M. Serdyuk, L. G. Andriyenko; DOKLADY AKADEMII NAUK UKRAINSKOY SSR. SERIYA B. GEOLOGICHESKIYE, KHIMICHESKIYE I BIOLOGICHESKIYE NAUKI, Jun 83).....	16
Immunobiologic Effects of Decimeter Band Electromagnetic Field on the Thyroid (S. B. Pershin, et al.; ZHURNAL MIKROBIOLOGII EPIDEMIOLOGII I IMMUNOBIOLOGII, Apr 83).....	21
Calculation of Optimum Parameters for SHF Treatment of Fish Stuffing (S. V. Simov'yan, V. A. Potapov; PISHCHEVAYA TEKHNLOGIYA, May-Jun 83).....	22
Labor Hygiene in Technical Testing of Magnetic Materials (Yu. P. Syromyanikov, V. A. Roshchin; GIGIYENA TRUDA I PROFESSIONAL'NYE ZABOLEVANIYE, May 83).....	22
Effect of Microwave Treatment on Enzyme Activity (I. A. Popadich, et al.; PISHCHEVAYA TEKHNLOGIYA, May-Jun 83).....	23

EFFECT OF A CONSTANT MAGNETIC FIELD ON BLOOD CLOTTING INDICATORS

Riga IZVESTIYA AKADEMII NAUK LATVIYSKOY SSR in Russian No 1, Jan 83
(manuscript received 1 Apr 82) pp 84-91

[Text] Recently, physical factors, including magnetic fields, are being used more and more along with pharmacological means in the treatment of neuro-angiological conditions.

There has been systematic expansion in the research on the possibilities for using magnetic fields in the treatment of various syndromes of vascular diseases, including those affecting the brain. This is accompanied by the discovery of new therapeutic effects of magnetic fields, the simplicity, accessibility, and economy of their application, and the possibility of controlling the direction and dose of this factor's action.

It has been established that the effect of a magnetic field can alter the blood's clotting properties, but the results of these experimental and clinical studies are not uniform and are contradictory, since the authors used different parameters for the magnetic fields and varying exposures to the fields. Thus in an experiment on rats using a magnetic field with an intensity of 200 millitons with a 4-hour exposure repeated over 7 days, there was an acceleration in the beginning and end of blood coagulation and activation of the fibrinolytic system [10]. According to the data from another group of authors, with the application of a constant magnetic field with an intensity of 100-250 millitons for 10-30 min, there was a tendency among the patients for a decrease in the number of thrombocytes, but the blood clotting time did not change significantly [8].

In a study of blood clotting indicators in people working at an aluminum plant and subjected to a regular effect of a constant magnetic field with an intensity of approximately 5 millitons, a clear tendency toward hypocoagulation was observed, which in the author's opinion was caused by changes in the activity of the majority of plasma factors that are involved in all phases of blood clotting [6].

A therapeutic anticoagulant effect was obtained by applying a constant magnetic field (10-30 millitons) using the contact method (with small magnets) [14]. In an experiment on rabbits, a hypocoagulation effect was also observed with the application of a constant magnetic field with a 20 milliton intensity [11]. In

another instance, however, in an experiment on rabbits under the influence of a magnetic field, there was an increase in aggregation and adhesion of erythrocytes and thrombocytes, and an increase in the coagulation properties of the blood and formation of intravascular conglomerates [5]. In this case the author applied a magnetic field with an intensity from 60 to 100 millitons and the entire body of the animal was exposed to the magnetic field. I. A. Kirchenko [7] conducted research on patients with ischemic heart disease and hypertension and demonstrated a favorable effect on the dynamic functions of thrombocytes with the application of a constant magnetic field with an intensity of 15 millitons.

Therefore, according to preliminary data, it has been determined that the methods used in the application of a magnetic field play a decisive role in the adequate correction of blood clotting properties. Additional, comprehensive research on hemostatic indicators was required in order to confirm this effect. This was the goal of the present study.

On the basis of the results of our previous research [13,15], to obtain an anticoagulant effect we selected small cylindrical magnets made of an SmCO_5 alloy, 10-30 mm in diameter and 6-10 mm long, with induction at the pole of 280-400 millitons. The magnets were relatively light and convenient to apply, and were distinguished by a high degree of stability in the parameters of the magnetic field.

With the aim of obtaining preventive and therapeutic anticoagulant effects, we used magnets with inductions equal to 10, 20, 30, and 50 millitons within the blood vessels. The magnets were fixed to the skin on the lower third of the forearm in the area of the radial artery. The exposure time depended on the force of the magnetic field and ranged from 1-7 days.

When selecting the parameters and exposure time for the magnetic fields to obtain the desired therapeutic hypocoagulation effect, we also took into account research [3] which showed that the basis for treating various diseases with magnetic fields is the nature of the body's adaptation responses to external irritation, which corresponds to the mobilization of its resistance with the least energy expenditures. The authors of that study established that the responses of training and activation create in the body the optimal internal environment, and mobilize the body's defense functions. However, if the chosen irritant is too strong, then a stress response occurs in the body which can develop into a pathological condition with extended activity of the body's defense mechanisms. Research done by these authors has shown that one of the signs of the stress response is the hypocoagulation effect; the training response is characterized by marked hypocoagulation; and the activation effect is characterized by stabilization of the clotting system and the blood's anticoagulation action.

Our previous research has shown that contact-distant or local effects from small magnets made of an SMCO_5 alloy create in the body conditions for the development of stable, prolonged hypocoagulation effects and the blood's clotting properties return to normal only 1-2 weeks or more after the action of the magnetic field has ended. In our opinion, these two phases in the status of the blood clotting system correspond to the training and activation responses [3].

The basis for our selection of the contact method of applying constant magnetic fields with small magnets, oriented toward an arterial vessel, is explained in the model shown in Figure 1.

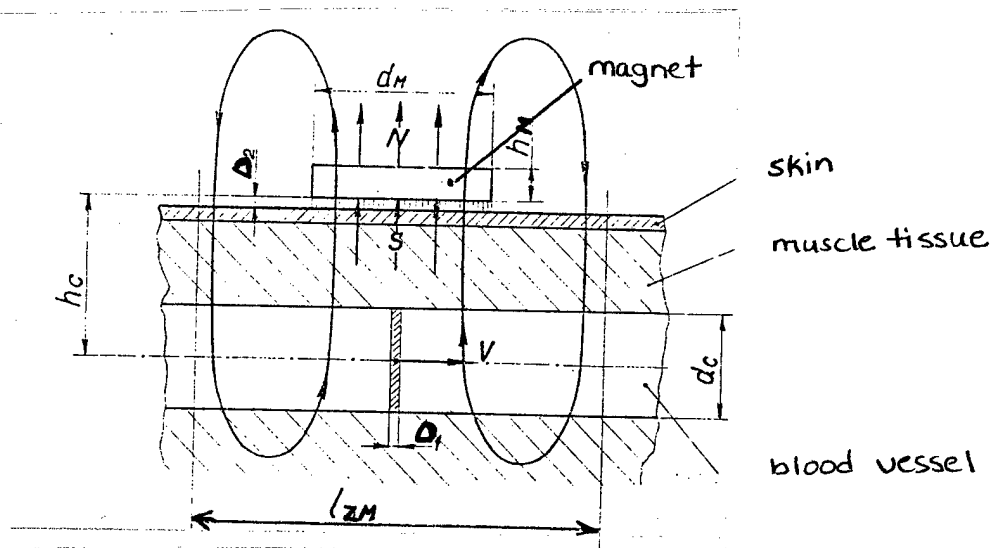

Figure 1. Model of contact action of a constant magnetic field on an arterial vessel. Abbreviations: d_c - diameter of the vessel; h_c - distance from magnet to axis of vessel; V - velocity of blood flow through vessel; D_1 - thickness of a single layer of formed elements in blood; d_m - diameter of magnet; h_m - height of magnet; N, S - poles of magnet; D_2 - thickness of pad between magnet and skin; l_{zm} - zone of action of constant magnetic field.

The parameters of the magnet and the zone of action of the constant magnetic field shown in the model are: $d_m = 15.30$ mm; $h_m = 10.12$ mm; the magnetic induction at the base of the magnet is $I_m = 280.400$ millitons; the magnetic induction at a distance 5 mm from the base of the magnet's pole is $I_m = 10.50$ millitons; the length of the zone of action of the magnetic field is $l_{zm} = 3d_m = 3(15.30)$ mm; $D_2 = 0.3$ mm.

The parameters of the blood vessel are $d_c = 3.6$ mm; $h_c = 1.56$ mm; $V = 20$ cm/sec; the thickness of one layer of formed elements is $D_1 = 2$ microns. The exposure to the magnetic field lasted 5-7 days. When the calculations were made, it was assumed that the volume of blood passing through the vessel was approximately 4 liters.

Using the model that has been described, it was possible to make an approximate calculation of the total time of magnetization for one layer of formed elements in the blood over 7 days (the maximum duration of one magnetization session in our study).

If we take the diameter of the vessel d_c to be 4 mm, its cross-section is

$$S_c = \frac{\pi d_c^2}{4} = \frac{3.14 \cdot 4^2}{4} = 12.52 \text{ mm}^2.$$

In 1 hour, a volume of blood equal to $V_{lc} = S \cdot V = 0.125 \cdot 20 = 2.5$ ml/sec passes through the zone of action of the constant magnetic field; the zone of action of the constant magnetic field with $d = 20$ mm is $l = 3 \cdot 20 = 60$ mm. A single layer of formed elements in the blood with a thickness of $D_1 = 2$ microns passes through the zone of action of the constant magnetic field in $t_{D_1} = l/V = 60/20 = 0.3$ sec. The same single layer of formed elements will pass through the zone of action of the constant magnetic field a second time after 4 liters of blood have flowed through, that is, all the blood located outside of the depot. In this case, the period of magnetization of a single layer of formed elements will be equal on the average to the ratio between the total volume of blood V to the volume of blood that passes in 1 sec at V_{lc} , that is,

$$T = \frac{V}{V_{lc}} = \frac{4 \cdot 10^3}{2.5} = 1.6 \cdot 10^3 \text{ sec} \approx 27 \text{ min.}$$

The calculations show that a single layer of formed elements in the blood is exposed to the magnetic action for only 0.3 sec, with a 27 min interval between repeated exposures. Thus, during the exposure time t_{ex} , the total time of action of the magnetic field on a single layer of formed elements is

$$t_{mag} = \frac{t_{ex}}{T_{D_1}} t_{D_1} = \frac{24 \cdot 60}{27 \cdot 60} \cdot 0.3 = 1.8 \text{ min.}$$

Thus what seems to be prolonged magnetization is actually magnetization in a series of impulses, as shown in Figure 2. The number of cycles of magnetization

$$N = \frac{t_{mag}}{T_{D_1}} = \frac{108}{0.3} = 360.$$

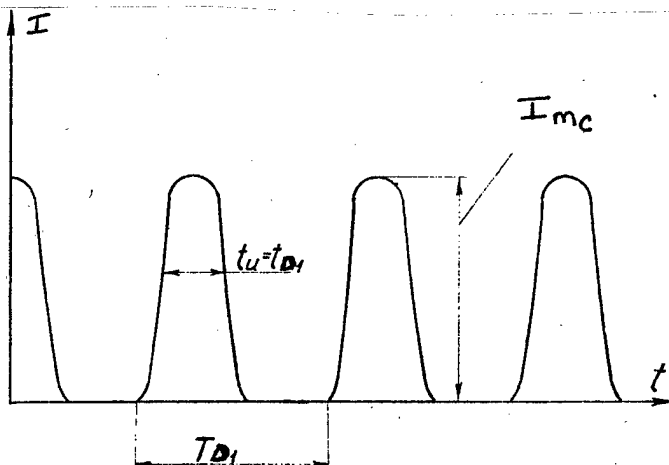

Figure 2. Diagram of the action of a constant magnetic field on a single layer of formed elements in the blood. Abbreviations: I - Size of magnetic induction; I_{mc} - maximum magnetic induction acting on the vessel; T_{D_1} - duration of movement through magnetization of single layer; $t_u = t_{D_1}$ - length of an impulse of the constant magnetic field acting on the single layer of formed elements.

Thus by choosing the geometrical measurements (diameter, height) of the magnet and the size of magnetic induction, and knowing the parameters of the vessel and the velocity of blood flow through the vessel, one can change the length of the magnetization impulse on a single layer of formed elements and the duration of movement through the impulses; and by changing h_c , the size of the magnetic induction I_{mc} on the vessel can be changed.

On the basis of theoretical substantiation and experimental research, we studied under clinical conditions the effect of this method of magnetization on various indicators of blood clotting properties.

The research was done on 52 patients with initial signs of incomplete blood circulation in the brain, caused by atherosclerosis of blood vessels supplying the brain. All those with contraindications for anticoagulation therapy were excluded from the study. Varying degrees of a marked tendency toward hypercoagulation were observed among the patients in the initial stage.

Analyses of the blood were done immediately prior to application of the magnet, 1-3 times during magnetization, and on the first and fifth days after the magnet was removed.

We monitored the dynamics of whole blood clotting time using Birker's method; we counted the number of thrombocytes using a Goryayev chamber and phase-contrast microscopy; also taken into account were indicators from a thromboelastogram (TEG), p, k, t, T, and MA; an autocoagulation test was performed according to Besard's method (1965) with subsequent analysis of the T_1 , T_2 , A, MA, IIT indicators. Aggregation properties of thrombocytes were determined according to J. R. O'Brien's method (1962) with a modification by N. I. Tarasova (1974), taking into account the small, medium, and large aggregates formed in the second minute of aggregation. The intensity of the process of disaggregation was determined from the number of large aggregates remaining 10 minutes after the onset of the aggregation process. The hematocrit was also determined.

The constant magnetic field applied according to our method caused a hypocoagulation effect among the patients; the degree of the effect depended primarily on the size of the magnetic induction and the exposure time.

As Figure 3 shows, the effect of 7-days' exposure to a constant magnetic field with an induction of 10 millitons was a clear increase in the clotting time for whole blood within the vessel; the average increase was 32.1 percent ($t > t_{0.05}$; $3.21 > 3.05$). When a magnetic field was applied with an intensity of 20 millitons over a 5-day period, there was an average increase in blood clotting time of 63.2 percent ($t > t_{0.05}$; $4.18 > 2.26$). The most pronounced increase in clotting time was obtained when we used a magnet with an intensity of 30 millitons for only 2 days; there was a 163 percent increase in clotting time ($t > t_{0.05}$; $9.64 > 2.13$). A magnetic field within the limits of 30 millitons in this case turned out to be the optimal for the most rapid and most pronounced increase in clotting time. With a greater increase in the intensity of the constant magnetic field, the degree of change in whole blood clotting time decreased. For example, with an induction of 50 millitons, clotting time increased by only 39.4 percent (see Figure 3).

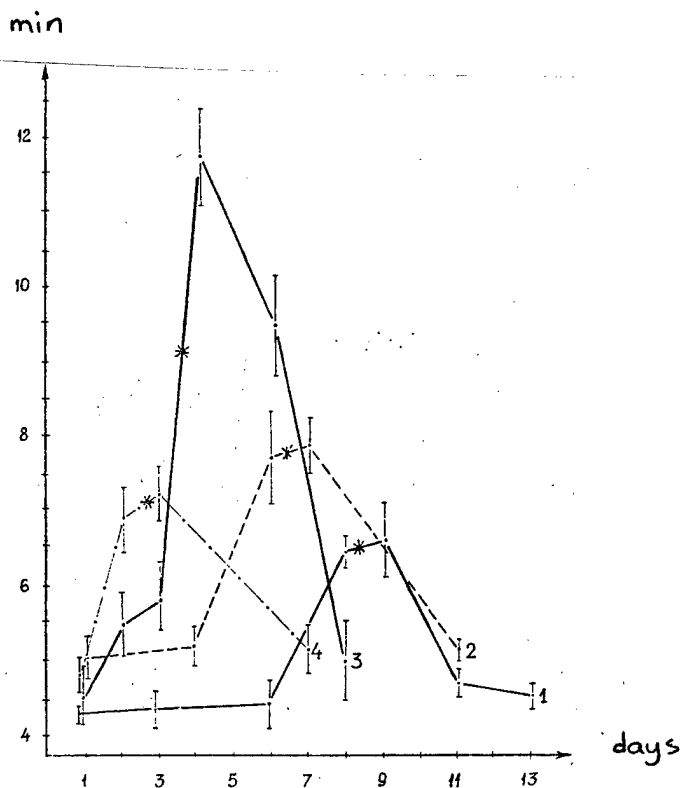

Figure 3. Changes in average indicators of whole blood clotting time (in min) under the influence of a constant magnetic field of 10 millitons (1), 20 millitons (2), 30 millitons (3), and 50 millitons (4). The symbol * indicates termination of the constant magnetic field activity.

There was a decrease in the activity of thromboplastin and thrombin that was parallel to the increase in blood clotting time resulting from exposure to a constant magnetic field with a given intensity. This is shown in the reduction in the indicators A and MA, and the increase in T_1 , T_2 , and the autocoagulation test. From the application of a constant magnetic field with an induction of 30 millitons, the indicator A declined from an initial 52.4 ± 9.2 percent to 32.2 ± 7.7 percent on the third day of exposure to the magnetic field ($t < t_{\alpha, \gamma}$; $1.59 < 2.13$). The indicator MA showed a less significant decrease (from 105 ± 0.9 percent to 100.2 ± 0.7 percent). The time segment T_1 increased from the initial 1.94 ± 0.34 min to 3.31 ± 0.33 min on the third day of magnetization ($t > t_{\alpha, \gamma}$; $2.74 > 2.13$). In addition to the shifts in the indicators already noted, there was an increase in the time required to reach maximum clotting activity T_2 --from a baseline average of 7.10 ± 0.20 min to an average of 8.50 ± 0.90 min at the time magnetization was terminated ($t < t_{\alpha, \gamma}$; $1.43 < 2.13$).

We compared the changes in the autocoagulation test indicators to the dynamics of the data from the thromboelastograms; on the third day of magnetization there was an increase in the time segments on the thromboelastograms: p increased from 10.5 ± 0.9 min to 12.5 ± 0.8 min; k increased from 5.8 ± 0.6 to 6.9 ± 1.0 min; and T increased from 31.8 ± 1.3 to 48.1 ± 4.8 min.

Thus, we see that the initial phases (I and II) in the blood clotting process were more sensitive to the effects of constant magnetic fields with the given induction.

It must be emphasized that the changes in the blood coagulation system were not identical; and in addition to the changes already mentioned, we observed some compensation responses in the opposite direction that helped maintain an overall balance in the complex process of blood clotting. There was a decrease in the value of the IIT in the autocoagulation test. After 2 days of magnetization by a constant magnetic field with an induction of 30 millitons, the value of the IIT in the autocoagulation test decreased from 1.79 ± 0.11 to 1.44 ± 0.11 ($t > t_{\alpha, \nu}$; $2.16 > 2.13$) after the magnet was removed; this indicates a decrease in the activity of slow-acting antithrombins (primarily antithrombin III) and a decrease in the process of fibrinolysis.

After the exposure to constant magnetic fields, there was an increase in the maximum amplitude of the curve (MA) on the thromboelastogram; that is, there was an increase in the quantity and quality of the fibrin.

In all the cases that we observed, there was an increase in the number of circulating thrombocytes in the blood in connection with the effect of the constant magnetic fields applied according to our method. This was also clearly a compensation response. With the increase in the number of thrombocytes, there was a greater concentration of thrombocytic clotting factors. With the application of constant magnetic fields with intensities of 10, 20, and 30 millitons, the number of circulating thrombocytes increased on the day the magnetization was terminated from $225,000 \pm 18,000$ to $267,000 \pm 15,000$; from $260,000 \pm 25,000$ to $295,000 \pm 23,000$; and from $235,000 \pm 26,000$ to $333,000 \pm 22,000$, respectively.

Under the influence of constant magnetic fields, the aggregation properties of thrombocytes changed in different directions depending on the intensity of the induction of the fields, as Figure 4 shows. In the majority of cases these changes were statistically insignificant and appeared in the form of a more pronounced tendency.

A tendency toward hypoaggregation was observed as an effect of constant magnetic fields with inductions of 10 and 20 millitons; and when the magnet was removed there was an increase in the number of free thrombocytes and small aggregates, and a decrease in the number of large aggregates. On the sixth day after magnetization with 20 millitons, the number of free thrombocytes increased by an average of 10.8 percent ($t < t_{\alpha, \nu}$; $0.43 < 2.26$); the number of small aggregates increased by 3.3 percent ($t < t_{\alpha, \nu}$; $0.26 < 2.26$); the number of medium aggregates increased by 1.8 percent ($t < t_{\alpha, \nu}$; $0.09 < 2.26$); the number of large aggregates decreased by an average of 11.6 percent ($t < t_{\alpha, \nu}$; $0.72 < 2.26$). This indicates a relative reduction in the intensity of the process of thrombocyte aggregation. Thus, under the influence of constant magnetic fields, there was not only an increase in the number of free thrombocytes, but also an increase in the number of small and medium aggregates, which is clearly tied to the decrease in the number of large aggregates.

Under the influence of a constant magnetic field with an intensity of 30 millitons, on the second day there was a significant (39 percent) increase in the number of free thrombocytes over the initial level ($t > t_{\alpha, \nu}$; $3.40 > 2.13$); there was an increase in the number of small and medium aggregates (an average of 4.8 percent); and a 2.0 percent decrease in the number of large aggregates. On the third day, however, the opposite effect was observed: the number of free thrombocytes decreased and the deviation from the initial level did not exceed 4.8 percent; the number of small aggregates increased by 18.5 percent; the number of large aggregates increased by an average of 58.3 percent ($t > t_{\alpha, \nu}$; $2.18 > 2.13$). This is evidence of the increase in the thrombocytes' aggregation properties.

The tendency toward hyperaggregation of thrombocytes was observed with the application of a constant magnetic field with induction equal to 50 millitons; there was a decrease (1.4 percent) in the number of free thrombocytes; a decrease (7.7) in the number of small aggregates; and increase in the number of medium and large aggregates (7.5 percent and 13.0 percent, respectively), but these shifts turned out to be insignificant.

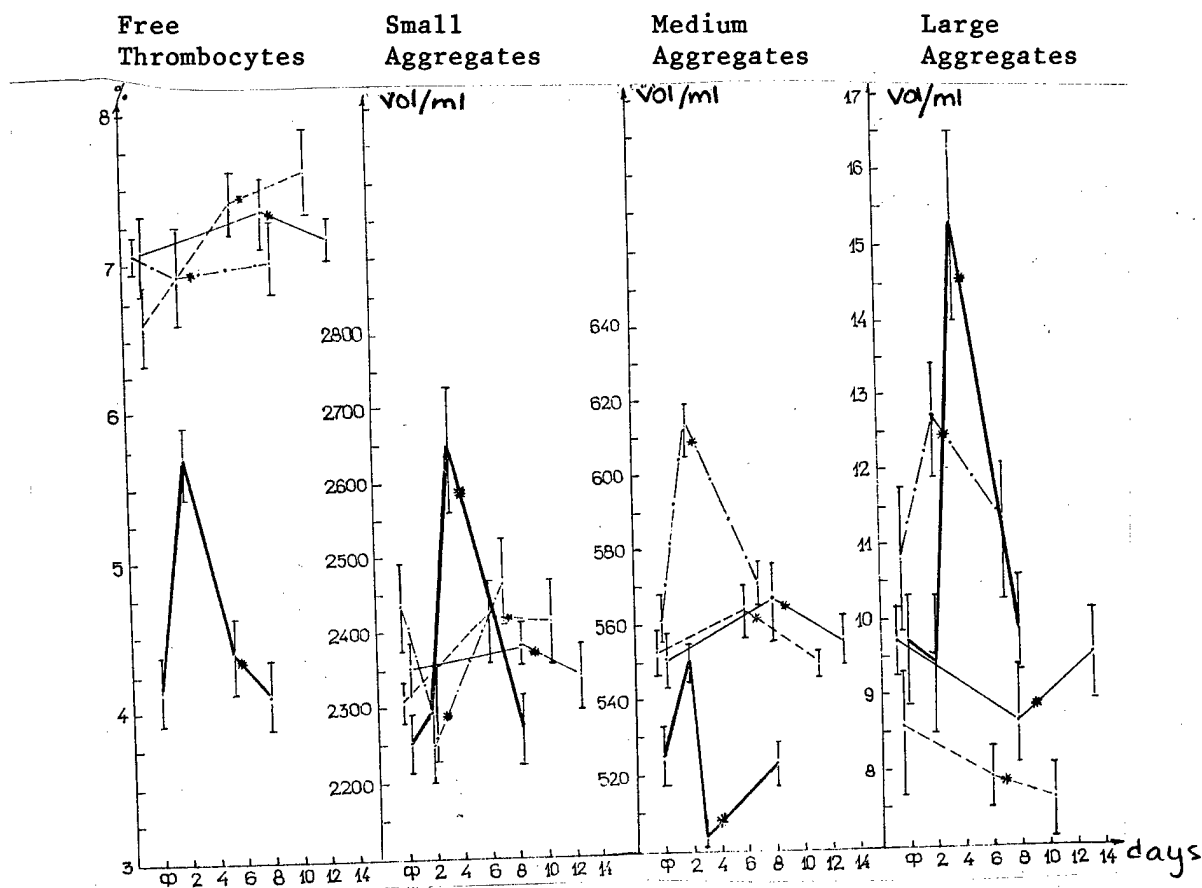

Figure 4. Changes in the aggregation properties of thrombocytes under the influence of constant magnetic fields with inductions of 10, 20, 30, and 50 millitons. Abbreviations are the same as in Figure 3. ϕ is the initial level of the thrombocytes' aggregation properties.

Thus, a constant magnetic field applied to a blood vessel using the contact method, with inductions from 10 to 30 millitons, caused hypocoagulation and hypoaggregation tied to a slowing down of the initial phases in the blood clotting process. The most uniform anticoagulation effect was obtained with 10-20 millitons, which makes it possible to recommend therapeutic application of constant magnetic fields in the treatment of hypercoagulation and hyperaggregation conditions. Constant magnetic fields, with inductions of 30 millitons, can be used to obtain a more rapid and more pronounced hypocoagulation effect; however, the time periods for application of a field with this intensity are limited, since a hypercoagulation response may be elicited. Contact application of constant magnetic fields with induction over 30 millitons on vessels for therapeutic and preventive correction of blood clotting properties is not recommended.

BIBLIOGRAPHY

1. Baluda, V. P. and Barkagan, Z. S., "Laboratornyye metody issledovaniya sistemy gemostaza" [Laboratory Methods for Studying the Hemostatic System], Tomsk, 1980
2. Barkagan, L. Z., "Methods and Tactics for Recognizing Problems in Blood Clotting", LAB. DELO, No 4, 1980, pp 195-199.
3. Garkavi, L. Kh., Kvakina, Ye. B., and Ukolova, M. A., "Adaptatsionnyye reaktsii i rezistentnost' organizma" [Adaptation Responses and the Body's Resistance], Rostov, 1979.
4. Gilinskaya, N. Yu. and Olesov, G. V., "Perspectives in the Application of Magnetic Fields in Vascular Diseases of the Brain", in "Tezisy dokladov Kuybyshev Oblast Konferentsii 'Primeneniye magnitnykh poley v klinike'" [Paper Abstracts from the Kuybyshev Oblast Conference "The Clinical Applications of Magnetic Fields"], Kuybyshev, 1976, pp 32-34.
5. Demetskiy, A. M., "The Response of the Cardiovascular System and the Blood to the Action of Artificial Magnetic Fields", in "Magnitobiologii i magnitoterapiya v meditsine. Tezisy dokladov Vsesoyuznoy naucho-prakticheskoy konferentsii" [Magnetobiology and Magnetotherapy in Medicine. Paper Abstracts from the All-Union Scientific and Practical Conference], Vitebsk, 1980, pp 37-39.
6. Zabrodina, L. V., "On the Effect of Magnetic Fields on the Blood Clotting System in Workers at an Aluminum Plant Electrolysis Shop", in "Magnitnoye pole v meditsine" [The Magnetic Field in Medicine], Frunze, 1974, pp 61-64.
7. Kirchenko, I. A., "Dynamic Functions of Thrombocytes in Patients with Ischemic Heart Disease and Hypertension with Magnetic Field Treatment of 15 and 25 milliton Intensity", in "Aktual'nyye voprosy magnitobiologii i magnitoterapii" [Current Issues in Magnetobiology and Magnetotherapy], Izhevsk, 1981, pp 149-151.

8. Liyepa, I. E., Slutskiy, L. I., Kikut, R. P, et al., "The Effect of a Constant Magnetic Field on Several Peripheral Blood Indicators under Clinical Conditions", in "Magnitnoye pole v meditsine", op. cit., pp 15-18.
9. Miller,, L. A. and Detlav, I. E., "The Application of Magnetotherapy in Patients with Sequelae of Disrupted Blood Circulation to the Brain", in Tez. Dokl. nauchno-prakticheskoy konf., op. cit., pp 148-149.
10. Prizhevoyt, G. N. and Abdullina, Z. M., "The Effect of a Magnetic Field on the Blood Clotting and Fibrinolytic Systems in Tumor Patients", in "Magnitnoye pole v meditsine", op. cit., pp 70-73.
11. Sosnovik, G. I., Bazenko, N. P., and Pyshenko, M. V., "On the Mechanism of Action of Magnetic Fields on the Blood Clotting System", in "Magnitobiologii i magnitoterapii...", op. cit., pp 55-58.
12. Troshin, V. D., Semenova, Ye. P., Starikova, N. V., et al., "The Application of Variable Low-Frequency Electromagnetic Fields in the Treatment of Vascular Diseases of the Brain", in "Aktual'nyye voprosy...", op. cit., pp 167-168.
13. Chernyakov, V. A. and Eninya, G. I., "On Selecting the Size of Magnetic Induction in the Treatment of Diseases of the Vascular System", in "Magnitobiologii i magnitoterapii...", op. cit., pp 121-128.
14. Eninya, G. I., Chernyakkov, V. A., Dagile, I. A., and Maykov, V. G., "A Method for Treating Thrombosis", USSR Patent No 891099, OTKRYTIYA. IZOBRETENIYA. PROMYSHLENNYYE OBRAZTSY. TOVARNYYE ZNAKI., No 47, 1981, pp 15-18.
15. Eninya, G. I., Chernyakov, V. A., Ayde, Kh. B., et al., "Mechanisms and Methods for the Application of Constant Magnetic Fields in the Treatment of Cerebrovascular Occlusions", in "Aktual'nyye voprosy...", op. cit., pp 87-89.

COPYRIGHT: Izdatel'stvo "Nauka", "Izvestiya Akademii nauk Latvviyskoy SSR, 1983

9967

GSO: 1840/603

USE OF A PERMANENT MAGNETIC FIELD TO TREAT DYSTROPHIC DISEASES OF THE LIMBS

Moscow SOVETSKAYA MEDITSINA in Russian No 10, Oct 82 (manuscript received 16 Jun 81) pp 115-117

[Article by V. M. Lirtsman, A. S. Imamaliyev and B. I. Yakubovich, Traumatology and Orthopedics Clinic, Central Scientific Research Institute of Traumatology and Orthopedics, Moscow City Clinical Hospital No 59]

[Text] Both permanent and alternating magnetic fields have been used extensively in recent years to treat injuries and diseases of the locomotor-bearing apparatus. Numerous studies by researchers have shown that a magnetic field, which is a biologically active agent, does have a pain-relieving and antiinflammatory action, it increases tissue permeability, and it accelerates reparative regeneration of injured soft tissues and bones.

A significant number of patients seeking aid in polyclinic orthopedic offices are persons with diseases of the locomotor-bearing apparatus based on degenerative-dystrophic processes in tendons, ligaments and other formations encountered around joints.

Such diseases include humeroscapular periarthrititis, epicondylitis, styloiditis and aseptic inflammation (bursitis) of synovial bursae in the vicinity of the knee joint. In young and middle-aged patients these diseases are the consequences of microtraumas, while in old and senile patients they often arise on the background of age-related changes in the locomotor-bearing apparatus. Trauma, strain or chilling are often the trigger mechanisms of these diseases.

The unique features of these disease include a pronounced pain syndrome, restricted movement in the joint, and a prolonged and persistent course coupled with impairment of general and job-related performance.

The therapeutic resources include physiotherapeutic treatments (electrophoresis, phonophoresis, microwave therapy), which are often combined with analgesics, butadione, reopirin and brufen. However, the effectiveness of physiotherapy cannot be said to be sufficiently high; moreover many patients exhibit contraindications to physiotherapeutic methods of treatment (pathology on the part of the cardiovascular system, oncological diseases and so on).

Acupuncture is effective against humeroscapular peri-arthritis, epicondylitis and styloiditis, on the condition that patients tolerate such treatment well and that the entire prescribed course of treatment is carried out.

X-ray therapy in antiinflammatory doses is used in especially serious cases. This method is rather effective, but if no response occurs, physiotherapeutic treatments cannot be prescribed for a rather long time after x-ray therapy.

Injection of hydrocortisone emulsion into the joint area at the pain point has enjoyed widespread acceptance in daily treatment practice. Essentially a pathogenic treatment method, it causes stable pain relief and restoration of articular mobility in most patients. However, this method is contraindicated in relation to acute and chronic inflammatory processes, diabetes and osteoporosis, and it requires the strictest possible compliance with the rules of asepsis in view of the danger of suppurative complications.

In 1977 V. V. Kuz'menko, V. M. Nadgireyev and Ye. P. Gorbacheva reported successful use of a permanent magnetic field to treat humeroscapular peri-arthritis, subcalcanal bursitis and deformative arthrosis of the knee joint. The pathological focus was exposed to the action of elastic magnets (magneto-phores)--permanent magnets in the form of specially developed rubber plates that were placed directly on the skin along the axis of the limb and secured with a bandage. The dimensions of the elastic magnets varied; according to the authors the magnetic field intensity varied from 250 to 360 Oe; exposure time was 16-18 hours per day for 5-10 days.

Pain intensity usually decreased in 1 or 2 days. A stable positive result coupled with complete disappearance of the pain syndrome was observed on the 3rd through 10th days. Investigation of the remote consequences of treatment from 2 months to 1.5 years after treatment showed that recurrence of disease was not observed in most patients, while periodically arising pain in the rest of the patients was of much lesser intensity than prior to magnetotherapy.

Despite the fact that the mechanism of action of a permanent magnetic field has not yet been fully studied, the dependence of therapeutic effect on field intensity and time of exposure has been established experimentally and clinically. In our opinion the orientation of the magnetic flux lines and the shape of the magnetic field created by multipolar magnets (see Figure) may have certain significance.

This communication describes the first attempt to use a permanent magnetic field created by multipolar magnets to treat some degenerative-dystrophic diseases of the locomotor-bearing apparatus. Multipolar magnets used in the clinic are round metallic rods with a diameter of 2mm; their length is 40mm for pentapolar magnets and 20mm for tripolar magnets. Magnetic field intensity varies from 300 to 400 Oe.

Penta- and tripolar magnets were applied to the area of maximum pain, as determined by palpation. They were isolated from the skin by a cotton gauze lining and secured to the skin by strips of adhesive tape and a tubular bandage. Exposure time was 10 hours per day for 10 days.

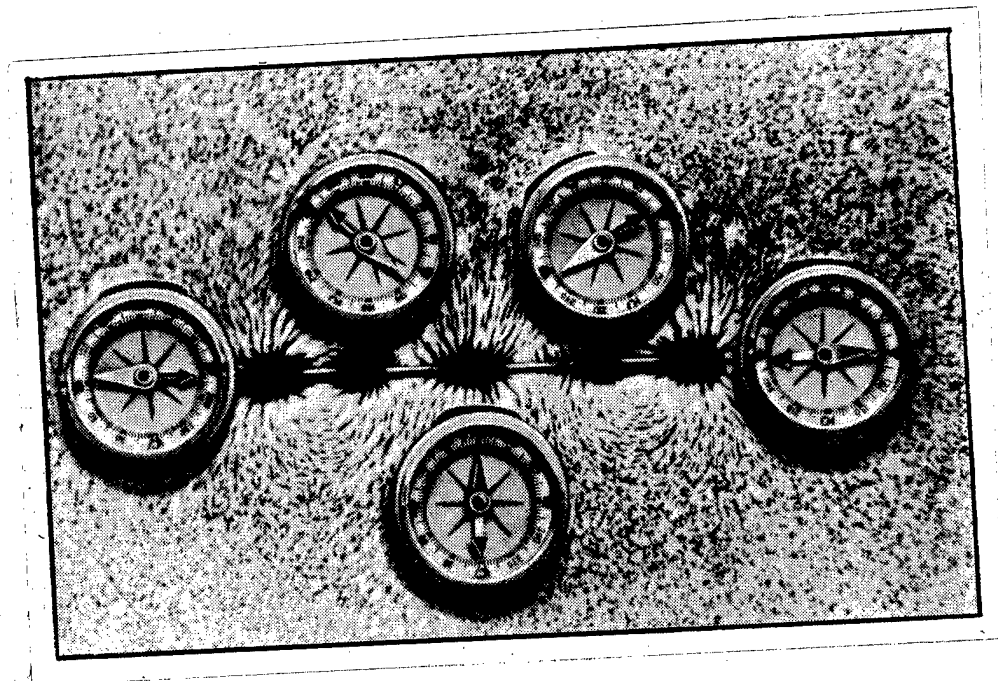

Orientation of Magnetic Flux Lines and
Shape of Magnetic Field of Pentapolar Magnet

From the text

When the treatment results were positive, pain usually decreased significantly after 3 days, and a sensation of pleasant warmth appeared in the area to which the magnet was applied. In some patients, pain increased slightly on the 4th-5th days, after which it disappeared and did not return.

The patients (50) were divided into three groups depending on the results of using the permanent magnetic field, observed in a period from 6 months to 1 year (see Table). Patients of group 1 did not experience noticeable relief from magnetotherapy; pain decreased somewhat only during the time of application or for a short period following it. Patients in group 2 first experienced a significant decrease in pain or its total disappearance, but following the course of treatment the pain gradually resumed and soon attained its previous intensity. Patients in group 3 exhibited complete and stable disappearance of the pain and recovery of mobility in the joint without recurrence of disease for not less than 6 months.

Following the course of magnetotherapy, therapeutic gymnastics, massage, water treatment and mechanotherapy, which led to complete recovery of movements in the shoulder joint, were prescribed to patients with severe contractures of the shoulder joint, often observed in the presence of humeroscapular peri-arthritis.

Effectiveness of Magnetotherapy in Relation to Some
Diseases of the Locomotor-Bearing Apparatus

<u>Disease</u>	<u>Number of Patients</u>	<u>Treatment Result</u>		
		<u>No Effect Short-Term Effect (Group 1)</u>	<u>Unstable Effect (Group 2)</u>	<u>Recovery (Group 3)</u>
Humeroscapular Periarthritis	10	-	-	10
Epicondylitis	18	8	2	8
Styloiditis	12	8	-	4
Bursitis of Knee Joint	10	2	2	6
Total	50	18	4	28

Investigation of remote results showed that pain disappeared completely and did not recur in the entire period of observation in 28 out of 50 patients. In four patients magnetotherapy provided only temporary relief, and in 18 it had no effect. These patients were subjected to a course of hydrocortisone injections into the pain point, which led to stable elimination of the pathological process.

A permanent magnetic field created by multipolar magnets can be used successfully in addition to elastic magnets to treat some diseases of the locomotor-bearing apparatus.

BIBLIOGRAPHY

1. Zulkarneyev, R. A., "Oshibki i oslozhneniya pri lechenii mestnymi in'yektsiyami glyukokortikoidov. Metod. rekomendatsii" [Mistakes and Complications Associated with Treatment by Local Glucocorticoid Injections. Methodological Recommendations], Kazan, 1973.
2. Kaptelin, A. F., Berglezov, M. A., Pavlova, G. A. et al., in "Aktual'nyye voprosy travmatologii i ortopedii" ["Pressing Problems of Traumatology and Orthopedics"], Moscow, Issue 21, 1980, pp 87-91.
3. Kuz'menko, V. V., Nadgireyev, V. M. and Gorbacheva, Ye. P., in "Klinicheskoye primeneniye magnitnykh poley" ["Clinical Use of Magnetic Fields"], Izhevsk, 1977, pp 53-54.

4. Mitbreyt, I. M., Adzhimolayev, T. A., Dormidontov, G. V. et al., Ibid., pp 57-58.
5. Nikitenko, I. K. and Zhil'nikov, V. M., Ibid., pp 51-52.
6. Nikol'skiy, M. A. and Alekseyev, A. P., Ibid., pp 61-62.
7. Savel'yev, V. N. and Ivanov, V. G., Ibid., pp 49-50.
8. Khabirova, G. F., Ibid., pp 62-64.

COPYRIGHT: "Sovetskaya meditsina", 1982

11004

CSO: 1840/521

EFFECT OF ELECTROMAGNETIC ENERGY ON GENERATIVE FUNCTION OF ANIMALS

Kiev DOKLADY AKADEMII NAUK UKRAINSKOY SSR. SERIYA B. GEOLOGICHESKIYE, KHIMICHESKIYE I BIOLOGICHESKIYE NAUKI in Russian No 6, Jun 83 (manuscript received 16 Nov 82) pp 76-79

[Article by A. M. Serdyuk and L. G. Andriyenko (presented by F. N. Serkov, academician of the Ukrainian SSR Academy of Sciences), Kiev Scientific Research Institute of General and Communal Hygiene]

[Text] In the last few years the development of communication and energy transfer systems has led to an exponential increase in the levels of anthropogenic electromagnetic fields. It has been demonstrated that electromagnetic radio-frequency fields have an unfavorable effect on some organs, systems and organisms as a whole.

There are contradictory reports on the damaging effect of electromagnetic fields on the functional state of the sexual system in man [1-5] and on the reproductive system in animals [6-9]. However, the effect of low-intensity electromagnetic fields on the fertility of animals and on the intrauterine and postnatal development of their offspring has not been studied up till now.

We investigated the generative function of animals (rats) under the effect of a low-intensity electromagnetic industrial- and super-high-frequency field, established the nature and changes and determined the possible remote consequences of the effect of the electromagnetic field on the organism.

The experiments were conducted on nonpedigree white rats weighing 120 to 140 grams (665 females and 337 males). A total of 728 fetuses were analyzed and 1,726 young rats of the first generation were examined.

The experimental animals were under the effect of electromagnetic industrial-frequency fields for 22 out of 24 hours during 165 days (135--experiment and 30--period of aftereffect). The conditions of the field's effect are as follows: group I, exposition; II, 1 and III, 0.5 kV/m.

The indicators of the state of the generative function were as follows: capacity for fertilization (determined according to the time from the day of mating until delivery), fertility (average number of young rats in a litter, their weight at birth and the number of stillborns), number of parturient females, which died during or after delivery, as well as anomalies in the development of offspring and the postnatal death of young rats.

The microstructure of gonads was studied. The following morphological and functional indices of spermatozoa were determined in males: concentration of spermatozoa in a cellular suspension prepared from testes with appendices; number of living and nonliving spermatozoa; correlation of normal atypical forms; functional activity of the mitochondria of testes (state of oxidative phosphorylation).

The state of spermatogenesis was evaluated according to the index of spermatogenesis, the average number of spermatogonia in a tubule and the number of tubules with a cast-off epithelium.

In addition to the enumerated general indices of the state of the reproductive function, the function of ovaries in females was studied by means of the vaginal test. The average length of a cycle and the number of normal and abnormal cycles per female in a month were determined.

The embryonal development of the offspring of experimental animals was investigated on the 20th and 21st day of pregnancy. The number of yellow bodies in ovaries and of the places of implantation and the general embryonal mortality were calculated during an autopsy. The macroanatomical method was used to detect the pathology of internal organs /10/.

Since the state of offspring is the determining index in the evaluation of the sexual function, in addition to an analysis of the embryonal material, the postnatal development of young rats of the first generation born from experimental animals was studied. The number of stillborn rats in every litter, their postnatal death up to the 21st day of development, line and mass parameters on the day of birth and on the 5th, 15th and 21st day of development and the time of unstucking of ears, sighting and hairing were recorded.

As the results of this investigation have shown, a prolonged systematic effect of an electromagnetic industrial-frequency field of an intensity of 1 to 5 kV/m has an unfavorable effect on the processes of reproduction of animals. The damaging effect is determined by the magnitude of intensity of the electromagnetic field and by the length of effect and depends on the sex of experimental animals. The effect of an electromagnetic field of an intensity of 0.5 kV/m does not significantly change the state of the generative function. An electromagnetic industrial-frequency field of an intensity of 1.5 kV/m disturbs the functional state of gonads and embryonesis, as well as the postnatal development of the offspring of experimental animals. As a rule, the capacity for reproduction is retained (cases of sterility of animals were not observed), which is not a convincing basis for a conclusion on the lack of effect on processes of reproduction /11/.

The following were common changes in the reproductive function for males and females: increase in the time from the mating of males and females up to delivery, small fetuses of offspring, increase in the number of stillborn rats and rats dying before the 21st day of life and cases of anomalies in development (individual defects in extremities, hematomas in newborn rats and retardation in the development of the hair cover).

Disturbances in the function of ovaries were established in females. The total length of the estrual cycle increased, the number of cycles per month was lowered, the number of normal cycles decreased sharply and the length of the stage of rest rose. Plethora (sometimes sharp) of the uterus and ovaries was noted during a morphological investigation. The dystrophy of epithelium cells of secondary follicles, induration of the stroma and detachment of the cells of the granular layer from the basal membrane detected in ovaries during a comparison with the disturbance in cycling point to the dysfunction of ovaries.

The inhibition of the reproductive function of males can be explained by the change in the functional indices of sexual glands. A decrease in the total number of spermatozoids and an increase in nonliving spermatozoa and in their atypical forms were observed. Hyperemia disorders and dystrophic and destructive changes developed against their background, which brought about a drop in the morphological indices of the spermatogenic epithelium, were noted during an investigation of the microstructure of gonads. The index of spermatogenesis was lowered, processes of desquamation of the generative epithelium in testes intensified and the number of immature forms of spermatozoa increased.

Since functional shifts in the sexual system of experimental animals did not reach the degree of sterility (in all cases offspring were obtained and the number of young rats in one litter in experiment and control was comparable) and defects in development and the functional inferiority of the growing organism are often detected after birth, we studied the postnatal development of young rats born as a result of cross mating. Differences in the development of the offspring of experimental females crossed with intact males, as compared with the offspring of intact females and experimental males, were established. An increase in general embryonal and postnatal mortality and a decrease in weight on the 1st, 5th, 15th and 21st day were observed in the offspring of experimental females, which points to a more severe damage of the generative function of females by the electromagnetic field.

The reproductive function of females (120 rats) under a 4-month effect of a super-high frequency 10-cm range field (energy flux density, 2,500, 500 and 100 $\mu\text{W}/\text{cm}^2$) was studied. A change in the generative function was established and the damaging effect was determined by the energy level. An increase in the time from the day of mating of females with males until delivery and in the number of young rats per litter was disclosed in the first group (energy flux density, 2,500 $\mu\text{W}/\text{cm}^2$).

It is well known that damaging factors can have not only a cytotoxic effect or disturb the structure of gonads of animals, but also produce changes leading either to the death of the zygote during fertilization or manifested later during the period of embryogenesis and development of offspring. Damaged sex cells are fertilizable. However, offspring can be nonviable.

We detected the following deviations during the postnatal period: decrease in the weight and length of the body of young rats in experimental females of the three groups on the 3rd, 5th, 15th and 21st day of the first month of life; increase in the periods of development of the hair cover and opening of eyes. These changes led to a decrease in the viability of offspring, which

was manifested under the conditions of effect of a physical load. The time of swimming of young rats, as compared with control, was sharply reduced in the three experimental groups. At the same time, during an investigation of embryonal development significant changes were not detected. Only an increase in the number of yellow bodies and places of implantation was noted. An increase in embryonal mortality was not observed. The damaging effect of this factor was manifested in offspring later--endurance for a physical load was lowered.

Thus, the results of this investigation have shown that reproductive organs are most sensitive to the effect of an electromagnetic field. At the same time, the generative function of females is damaged to a greater extent. The time from the mating of females with males until delivery, mass indices of offspring during the first month of life, periods of development of the hair cover and opening of eyes and tolerance for a physical load are especially significant.

BIBLIOGRAPHY

1. Minecki, L., "Ocena dzialania biologicznego pol electromagnetycznych willekx czegtotliwocei jako zawodowego czynnyke szkodliwego," MED. PRACY, 1963, 1, pp 75-84.
2. Artamonova, V. G., Kalyada, T. V., Khaymovich, M. L. et al., "Clinico-Hygienic Aspects of the Effect of a Low-Intensity Super-High Frequency Field on Workers," in the book "Voprosy gigiyeny truda i radioelektronnoy promyshlennosti" /Problems of Labor Hygiene and of the Radio Electronic Industry/, Moscow, 1979, pp 71-76.
3. Zotova, A. B. and Mambetaliyev, B. S., "Hygienic Evaluation of the Intensity of the Electromagnetic Field at a Hydroelectric Power Station," ZDRAVOOKHRANENIYE KIRGIZII, 1981, No 5, pp 3-7.
4. Gamberale, F., Knave, B., Bergstrom, S. et al., "Exposition for elektriska failt--En epidemiologisk halsundersokning av laugvarigt exponerade stalverkarbetare," Stockholm, Arbete och halsa--Vetenskaplig skriftseries, 1978, 10, 48 s.
5. Bridges, Jack B. and Preache, Maurline, "Biological Influences of Power Frequency Electric Fields--A Tutorial Review From a Physical and Experimental Viewpoint," PROC. IEEE, 1981, 69, N 9, pp 1092-1120.
6. Shutenko, O. I., "Gigiyenicheskaya kharakteristika elektromagnitnogo polya SVCh v usloviyakh naselennykh mest" /Hygienic Evaluation of an Industrial Frequency Electromagnetic Field According to Data of Investigation of the Generative Function/, author's abstract of his dissertation for the degree of candidate of biological sciences, Kiev, 1980, 23 pages.
8. Reznikov, A. G. and Tarasenko, L. V., "Effect of an Industrial-Frequency Electromagnetic Field on the Androgenic Function of Testes of Rats," FI-ZIOL. ZHURN., 1981, 27, No 1, pp 121-124.

9. Zaret, Milton M., "Nonionizing Radiational Injury of Humans," in "Eff. Biol. Rayoun. Non. Ionis. Utilis et Risques Associes. 9 eme Congr. Int.," Nainvilleges Roches, 1978, st. Denis, 1978, pp 337-355.
10. Dyban, A. P., "Basic Methodological Approaches to the Testing of the Tera-togenic Activity of Chemical Substances," ARKHIV ANAT., GISTOL. I EMBRIOL., 1970, 10, pp 89-100.
11. Sanotskiy, I. V., "Problems of Hygienic Standardization of Substances Af-fecting the Generative Function," in the book "Voprosy gigiyeny normiro-vaniya pri izuchenii ot-del'nykh posledstviy vozdeystviya promyshlennykh veshchestv" /Problems of Standardization Hygiene in the Study of Individ-ual Consequences of the Effect of Industrial Substances/, Moscow, 1972, p 78.

COPYRIGHT: Izdatel'stvo "Naukova dumka", "Doklady Akademii nauk Ukrainskoy SSR". Seriya B, 1983

11,439

CSO: 1840/573

IMMUNOBIOLOGIC EFFECTS OF DECIMETER BAND ELECTROMAGNETIC FIELD ON THE THYROID

Moscow ZHURNAL MIKROBIOLOGII EPIDEMIOLOGII I IMMUNOBIOLOGII in Russian No 4, Apr 83 (manuscript received 25 May 82) pp 76-79

PERSHIN, S. B., BOGOLYUBOV, V. M., KUZ'MAN, S. N., KOZLOVA, N. N., GALENCHIK, A. I., FRENKEL', I. D. and PONOMAREV, Yu. T., Central Scientific Research Institute of Health Resort Science and Physical Therapy, USSR Ministry of Health, Moscow; Moscow Scientific Research Institute of Vaccines and Sera imeni I. I. Mechnikov

[Abstract] A study was made of the immunologic potential of the organism, judged from the capability to develop primary and secondary immune responses, in connection with a change in certain endocrine functions upon exposure of the thyroid area to decimeter-band electromagnetic waves. Studies were performed on 97 male rabbits immunized i/v with thymus-dependent antigen at $2 \cdot 10^9$ cells to produce the primary immune response. The secondary response was induced by repeated injection of the antigen in the same dose after 30 days. Decimeter waves were applied by means of a contact ceramic radiator 0.04 m in diameter, flux density 120 mW/cm^2 each day for 6 minutes for 10 days. The decimeter waves produced both immunostimulating and immunodepressing effects depending on the relationship of decimeter wave exposure to the period of immunogenesis. The synthesis of nonspecific immunoglobulins is more resistant to the depressive effect of decimeter waves than the synthesis of specific immunoglobulins. Activation of the thyroid by decimeter waves occurs earlier than the immunostimulating effect. References 10: 4 Russian, 6 Western.

[720-6508]

CALCULATION OF OPTIMUM PARAMETERS FOR SHF TREATMENT OF FISH STUFFING

Krasnodar PISHCHEVAYA TEKHOLOGIYA in Russian Vol 154, No 3, May-Jun 83
(manuscript received 7 Jul 82) pp 78-81

SIMOV'YAN, S. V. and POTAPOV, V. A., Chair of Equipment for General Food Industry, Kharkov Institute of Public Nutrition

[Abstract] Mathematical considerations are presented for calculating the optimum conditions for SHF irradiation of oceanic-species fish-stuffing products. Particular attention is given to the low fat content and high moisture content of such products which are irradiated in glass tubes, and the selection of an appropriate resonator to assure homogenous heating. References 3 (Russian).
[631-12172]

UDC 613.647:621.318.1

LABOR HYGIENE IN TECHNICAL TESTING OF MAGNETIC MATERIALS

Moscow GIGIYENA TRUDA I PROFESSIONAL'NYYE ZABOLEVANIYE in Russian No 5, May 83
(manuscript received 4 Nov 82) pp 12-15

SYROMYANIKOV, Yu. P. and ROSHCHIN, V. A., Institute of Hygiene imeni F. F. Erisman, Moscow

[Abstract] A study was made of the conditions of labor and a number of indices of the state of health of workers in the quality assurance departments of enterprises producing permanent magnets. During measurement of the coercive force of magnets, one hand of the tester is placed in a homogeneous magnetic field in a coercimeter. Forty-four quality assurance testers (34 females, 10 males) were examined, including 29 under 40 years of age. Twenty had ten years or more in service, 8 had 5 to 9 years, 16--1 to 4 years. The studies showed that the workers had predominantly inert-type thermoregulation, a pathognostic indication of peripheral angiodystonic syndrome. A tendency toward capillary spasm was observed in many of the workers. Latent forms of peripheral angiodystonic disorders were revealed by the use of the cold test. The studies show that some magnetic materials testers exposed to local permanent and alternating magnetic fields had functional disorders of a number of physiological functions (inert type thermoregulation, capillary angiopathy, altered skin sensitivity). The preventive system should include creation of safe equipment and means for individual protection, preparation of hygienic recommendations and sanitary rules for working with magnetic materials. Figure 1; references 5 (Russian).
[718-6508]

EFFECT OF MICROWAVE TREATMENT ON ENZYME ACTIVITY

Krasnodar PISHCHEVAYA TEKHNOLOGIYA in Russian Vol 154, No 3, May-Jun 83
(manuscript received 3 Feb 82) pp 72-74

POPADICH, I. A., TRAUBENBERG, S. Ye., KULIKOVA, L. S. and MATISON, V. O.,
Chair of Analytical Chemistry, Order of the Red Banner of Labor Technological
Institute of the Food Industry, Moscow

[Abstract] Studies were conducted on the effects of microwave treatment of amylolytic enzyme preparations (Amylosubtilin G10kh and Gluconigrin G20kh) on their activities. Under the conditions employed (magnetron M-81 with an output of 2.5 kW at 2450 MHz), heating to temperatures above 60°C resulted in loss of enzyme activity, while at lower temperatures activities increased by 30-50% during short-term exposures. Addition of galactose, glucose, or mannose resulted in a 40-65% increase in enzyme activity of microwave-exposed Gluconigrin G20kh. Addition of Zn^{++} or Mn^{++} to Amylosubtilin G10kh resulted in 20-25% increase in enzyme activity following irradiation, while the effect on addition of Cd^{++} was on the order of 35%. Changes in activities were generally retained for 3 h. References 4 (Russian).
[631-12172]

- END -