

180146

JPRS-UMA-84-033

27 April 1984

19981016 095

# USSR Report

MILITARY AFFAIRS

DISTRIBUTION STATEMENT A  
Approved for public release;  
Distribution Unlimited

DTIC QUALITY INSPECTED

**FBIS**

FOREIGN BROADCAST INFORMATION SERVICE

REPRODUCED BY  
NATIONAL TECHNICAL  
INFORMATION SERVICE  
U.S. DEPARTMENT OF COMMERCE  
SPRINGFIELD, VA. 22161

6  
49  
A03

## NOTE

JPRS publications contain information primarily from foreign newspapers, periodicals and books, but also from news agency transmissions and broadcasts. Materials from foreign-language sources are translated; those from English-language sources are transcribed or reprinted, with the original phrasing and other characteristics retained.

Headlines, editorial reports, and material enclosed in brackets [ ] are supplied by JPRS. Processing indicators such as [Text] or [Excerpt] in the first line of each item, or following the last line of a brief, indicate how the original information was processed. Where no processing indicator is given, the information was summarized or extracted.

Unfamiliar names rendered phonetically or transliterated are enclosed in parentheses. Words or names preceded by a question mark and enclosed in parentheses were not clear in the original but have been supplied as appropriate in context. Other unattributed parenthetical notes within the body of an item originate with the source. Times within items are as given by source.

The contents of this publication in no way represent the policies, views or attitudes of the U.S. Government.

## PROCUREMENT OF PUBLICATIONS

JPRS publications may be ordered from the National Technical Information Service (NTIS), Springfield, Virginia 22161. In ordering, it is recommended that the JPRS number, title, date and author, if applicable, of publication be cited.

Current JPRS publications are announced in Government Reports Announcements issued semimonthly by the NTIS, and are listed in the Monthly Catalog of U.S. Government Publications issued by the Superintendent of Documents, U.S. Government Printing Office, Washington, D.C. 20402.

Correspondence pertaining to matters other than procurement may be addressed to Joint Publications Research Service, 1000 North Glebe Road, Arlington, Virginia 22201.

Soviet books and journal articles displaying a copyright notice are reproduced and sold by NTIS with permission of the copyright agency of the Soviet Union. Permission for further reproduction must be obtained from copyright owner.

27 April 1984

USSR REPORT  
MILITARY AFFAIRS

CONTENTS

ARMED FORCES

Effective Troop Control, Leadership Discussed  
(V. Ryabchuk; SOVIET MILITARY REVIEW, No 3, Mar 84)..... 1

Terms 'Flank,' 'Gap,' 'Limiting Point' Explained  
(SOVIET MILITARY REVIEW, No 2, Feb 84)..... 5

P-15 Radar Station Operation Described  
(V. Dedov; SOVIET MILITARY REVIEW, No 2, Feb 84)..... 7

Military Medical Support Services Defended  
(F. I. Komarov Interview; SOVETSKIY PATRIOT,  
26 Mar 84)..... 10

Role of Sergeants and Warrant Officers Cited  
(Editorial; KRASNAYA ZVEZDA, 20 Mar 84)..... 13

GROUND FORCES

March Possibilities Discussed  
(SOVIET MILITARY REVIEW, No 3, Mar 84)..... 16

Design, Operation Tank-Engine Clutch Discussed  
(M. Starostin; SOVIET MILITARY REVIEW, No 2, Feb 84)..... 18

Amphibious Tank Training Exercises Examined  
(A. Kondrashov; SOVIET MILITARY REVIEW, No 2, Feb 84)..... 21

AIR/AIR DEFENSE FORCES

Deputy Regimental Commander for Political Affairs Profiled  
(Yu. Nikitin; SOVIET MILITARY REVIEW, No 3, Mar 84)..... 24

Poor Performance Explained  
(S. Solarev; KRASNAYA ZVEZDA, 10 Mar 84)..... 28

SPECIAL TROOPS

Railroad Troop Commander Profiled  
(KRASNAYA ZVEZDA, 20 Mar 84)..... 30

Training for Railroad Troops Described  
(V. Ol'shevskiy; SOVETSKIY PATRIOT, 11 Mar 84)..... 32

DOSA AF

Results of DOSAAF Central Committee Plenum Summarized  
(Editorial; SOVETSKIY PATRIOT, 18 Mar 84)..... 35

Role of Women in DOSAAF Organizations  
(M. Alekseyev; SOVETSKIY PATRIOT, 3 Mar 84)..... 39

Improved Military-Patriotic Education of Kazakh Youth Stressed  
(S. Abdrakhmanov; KRYL'YA RODINY, No 11, Nov 83)..... 41

EFFECTIVE TROOP CONTROL, LEADERSHIP DISCUSSED

Moscow SOVIET MILITARY REVIEW in English No 3, Mar 84 pp 29-31

[Article by Major General V. Ryabchuk]

[Text]

**E**FFECTIVE troop control and leadership are among the most urgent and perhaps most complex problems facing the commanders and staffs in the Soviet Armed Forces today. "Effective control and leadership of troops," writes Marshal D. F. Ustinov, Defence Minister of the USSR in his book "Serving the Motherland and the Cause of Communism," "implies assured attainment of the objectives assigned and rational use of the combat capabilities of units and formations of the armed forces."

The present stage of development of military science and practice is often called "the stage of control and leadership." Indeed, there is every reason to do so. Radical changes in the military field have been brought about by new weapons, above all by the nuclear and thermonuclear ammunition. Further changes followed with the development of the nuclear delivery means, especially with the advances made in rocketry. The combat capabilities of troops radically increased, as they were equipped with a

variety of modern weapons systems.

Control and leadership of troops in battle has become especially significant in this situation, which is only too natural, since the more powerful the weapons at hand, the greater are the dangers of their improper use, and this imposes a tremendous responsibility on the commanders and staffs. So the present-day criterion of effectiveness of troop control primarily lies in the optimal coordination and employment of the available combat capabilities.

The factor of time has presently become more essential than ever for effective troop control and leadership. Yet reduction of the time of reaction, however drastic it may be, can no longer ensure effectiveness of control. Even a 10-fold acceleration of the control procedures may prove inadequate if the intended action is too late or too early. Effective control implies execution of control procedures and the combat operation proper within a shorter period of time than it takes the enemy to frustrate it or to minimise its effect.

Another material factor demanding better control and leadership is the present-day flood of operational information which the commanders and staffs face on the battlefield. The vast amount and complexity of the operational information are due to the increased scope and dynamic nature of the modern military operations, to the greater variety of the arms and services participating in the actions, and require greater efficiency in processing this information to take sound decisions.

Yet there is one more consideration which immensely increases control and leadership responsibilities on the modern battlefield. Now that nuclear warheads, as well as their delivery means are practically unlimited in yield, distance or accuracy, new limitations of fundamental significance are imposed on their use: ethical, humane, ecological possibility, political and military necessity of the use of superpowerful weapons, etc.

The essence of troop control and leadership consists in purposeful actions of commanders, staffs, political and other agencies to maintain constant combat readiness of troops, to organise and conduct the troops' all-round training for combat and to direct their efforts to accomplish the missions assigned. The main objective of control and leadership is to defeat the enemy through efficient use of the troops' capabilities, weapons and equipment.

The efficient use of weapons and the effects of their employment, just as destruction of such weapons available to the enemy and protection of friendly troops from enemy mass destruction weapons, in their turn require superior skill on the part of

the control and command agencies.

The problem of effective control is exceedingly complex. The major solutions can be found in further modifying the organisational structure of troops, command and control agencies, in seeking better forms and methods of activities of commanders and staffs, in developing and introducing automatic control systems, new signal communication equipment and other efficiency increasing means, as well as in upgrading the education and training of army officers, etc.

Let us review some of these aspects. The first is automation of troop control, for this is the main road to higher efficiency and reliability of troop control.

Automatic control is a logical and an objective trend in the military field. Indeed, the existence of highly efficient electronic computers capable of processing information tens and thousands times as quickly as the human mind and memorising and presenting it in any convenient form can hardly be overlooked by enemy military specialists and will surely be used at control and communications facilities. Hence it is crucial for all commanders and staffs to learn to handle the automatic equipment to the best advantage of troop control and leadership.

Further progress in troop command and control activities will greatly depend on the degree of comprehension of the objective need, purpose and conditions of automation, combat, economic and other criteria of the effectiveness of electronic equipment, as well as its relationship with the individual in combat and the effect of the automation on the preparation and conduct of military operations.

Automated troop control has been rightfully associated with present-day technological progress. But progress in technology is not enough, as it only opens up new opportunities for automation. The motive force for creating an automatic troop command and control system lies in the organic laws governing the development of the military practice and science and is generated by the intrinsic need for more optimal and efficient troop control.

Of no less importance are the problems of the purpose and priorities of putting the automatic equipment into service. Such essential aspects as the volume and operational speed of a system, the degree to which it can relieve physical and psychological strain and reduce staffs are all important but not equal, for some of them are primary and others secondary. So, automation of troop control should be based on a clear understanding of its primary and secondary purposes. The major purpose stays as always—to build up the combat capabilities of troops and raise their efficiency in defeating the enemy.

Also of primary importance is the fact that war demands not so much muscular and mental effort as conscientious and purposeful work. The commander's work is first and foremost creative activity. A soldier at war acts as a social being and a defender of a definite class interest which determines the nature of the war. Equipment, however advanced it may be, cannot obtain victory, it is the man that remains the decisive force on the battlefield. The major superiority of the Soviet soldier has always been in his devotion to and conscientious pur-

suit of the communist ideals and in his socialist patriotism.

A profound comprehension of all these factors, both technological and social, gives a clue to a proper understanding of the essence and prospects of development of automatic troop control. Opening up new and far-reaching opportunities for tackling present-day problems of troop control and leadership automation alone cannot accomplish this task unless it is properly coordinated with the organization of human activities in war. It is therefore essential to encourage initiative, creative effort and responsibility of commanders and staffs, to do everything possible to upgrade the educational and training standards of officers in troop command and control activities.

This aspect is generally given much attention to in the Soviet Armed Forces. However, there seem to be enormous untapped reserves in this field. Commanders learn how to drive tanks and other combat vehicles, how to handle or operate various weapons, and this is indeed important. But on the real battlefield a commander is not likely to often do such work: it will generally be done by the personnel; his primary task — to command — cannot be performed by anybody but himself. The commander bears exceptional personal responsibility for commanding his unit in the mission assigned, for leading it to victory over the enemy.

Commanders learn the fundamentals of troop control and leadership at military schools and academies. Along with that great demands are put on the practical handling of the modern command and

control equipment, including automatic and semiautomatic devices, as well as on the use of the advanced methods of situation analysis and prediction, e. g. mathematical modelling of the combat operations and the like. Especially important in this respect is properly organised, war-time oriented officer training in units and the conduct of command-post and field training exercises.

A new approach is also required to building the material base of officer training. The training base should include a system of tactical trainers, which could realistically simulate the dynamic nature of modern battle and provide proper conditions for practical troop control activities of commanders and staffs.

In short, the solution of the existing problems in raising the efficiency of troop control and leadership can only be found through a comprehensive approach in research and development coordinated with the vigorous practical activities of all commanders and staffs of the armed forces.

COPYRIGHT: "Soviet Military Review", 1984

CSO: 1812/158

## ARMED FORCES

### TERMS 'FLANK,' 'GAP,' 'LIMITING POINT' EXPLAINED

Moscow SOVIET MILITARY REVIEW in English No 2, Feb 84 p 19

[Article in "Modern Battle: Questions and Answers" column: "How Are Flank, Limiting Point and Gap Protected?"]

[Text]

A flank is a right (left) extremity of dispositions of a subunit or unit battle or route formation. When carrying out combat actions flanks are weaker parts of battle formation compared to the front and therefore more vulnerable.

A gap is a sector of the ground between the flanks of the adjacent subunits, units and formations in a single battle order.

A limiting point is a place of contact of flanks or a gap (interval) between the flanks of the adjacent formations, units and subunits having a boundary in their battle formation. Limiting points are the most vulnerable places for enemy blows. Therefore, when organising and carrying out combat actions it is very important to foresee and take measures to protect them.

The cover of flanks, gaps and limiting points rules out surprise enemy blows during the fulfilment of a combat mission. The necessity of protecting flanks and limiting points is engendered by their vulnerability due to the unusually low density of manpower and equipment and availability of gaps between adjacent units. For the purpose of protecting flanks and limiting points cooperation of the neighbouring subunits, units and formations is organised, constant on-the-spot reconnaissance is carried out, the necessary manpower and equipment, mainly the second echelons and reserves, are detailed and maintained in constant readiness for manoeuvre for flanks and limiting points, the blows of the rocket forces, aviation, artillery and other weapons are also planned, and installation of engineer obstacles is foreseen. The protection of flanks and limiting points is also envisaged in the commander's decision for battle and reflected in combat documents.

Measures to protect the flanks have been carried out in all wars. Originally the most wide-spread method of protecting the flanks was the use of the difficult ground for

the troops (rivers, mountains, lakes, etc.). Early in the 20th century a new notion, namely "protection of limiting points," was born in military art. Instructions on the necessity of their protection appeared in manuals of many armies after WWI. In the Soviet Armed Forces this demand was reflected in the Temporary Field Manual of the Workers' and Peasants' Red Army adopted in 1925 and later, in other field manuals.

The theory and practice of protecting flanks and limiting points was considerably developed during the Great Patriotic War. Organisation and execution of these measures had become an independent class of security. This enhanced the responsibility of commanders and staffs for the security of flanks and limiting points. A whole system of measures was worked out directly providing protection of flanks in the offensive, carrying out of continuous reconnaissance, detailing of mobile forces for actions on open flanks, sending out strong covering detachments in the event of enemy strikes, particularly in the course of encircling his groupings, advancement of the combined arms and special reserves, manoeuvre with artillery fire, delivery of air strikes, etc.

For the purpose of protecting flanks, gaps and limiting points on the defensive continuous observation was organised, antitank and antipersonnel obstacles were installed, the fire of small arms, artillery and aviation was planned and the execution of counterattacks against the enemy penetrated through the limiting point was foreseen. The organisation of gaps and limiting points was shaped in statements which were drawn up by headquarters of the neighbouring units with the participation of the representatives of the superior commander.

During the postwar period home and foreign literature and some official hand-books note that in a war involving modern weapons of destruction, combat operations in many cases will develop along specified directions and be based on centres of resistance and therefore open flanks will be commonplace. Limiting points between units and formations may represent considerable gaps not occupied by the forces. Therefore the system of measures for reliable protection of limiting points and flanks on the defensive will also include patrolling, setting up listening points and ambushes, thorough camouflage of limiting points and flanks and also building various decoy weapon emplacements.

On the offensive the commanders must carefully assess their neighbours so as to organise cooperation with them aimed at defeating the enemy on the flanks and using accessible directions for carrying out manoeuvre. The latter is of particular importance since in modern combat the situation may frequently arise when the only possibility for manoeuvring for a flank or a rear attack of the enemy strong point will be the use of neighbour's positions. Under these conditions the importance of measures concerning protection of flanks, gaps and limiting points is increasing still more, and their practical realisation will become part and parcel of the troops' combat actions.

ARMED FORCES

P-15 RADAR STATION OPERATION DESCRIBED

Moscow SOVIET MILITARY REVIEW in English No 2, Feb 84 pp 22-23

[Article by Colonel Engineer V. Dedov]

[Text]

Tension at the post was mounting. The operators fixed their attention on radar scopes, closely following the air situation. The advanced observation posts had already reported the appearance of "enemy" aircraft approaching at an extremely low altitude. It is very difficult to pinpoint a target blip on the radar scope amidst dense ground clutters. Knowing this, the "enemy" intended to secretly approach the assigned target.

But the operators managed to "catch" the target and were now plotting its route. This task is far from being easy. But the experience and high skill of the operators coupled with high technical capabilities of the P-15 radar station kept the command post continuously supplied with the required information.

Let us familiarise ourselves with the P-15 radar station. First of all we should note its high mobility (the entire station equipment and power supply are accommodated in one truck). The radar double-level antenna is mounted in the forward part of the truck

body. It is connected to the station's internal equipment through a turning drive and a waveguide transmission line. The antenna comprises two reflectors (upper and lower) and provides circular scanning of the space both in azimuth and elevation.

We ascend a metal ladder and open the cabin door. As soon as the eyes get accustomed to semi-darkness, we begin to discern unit lamps of various colours and the rotating sweep on the indicator screen. The silence in the cabin is disturbed only by the noise of cooling fans and the crackling of dischargers.

We shall start our examination of the cabin from the door, in a clockwise direction. On the left there is a bulky cabinet housing a transmitter. Its main components are high-voltage units designed to generate a DC voltage of about 10 kV and a high-frequency oscillator generating oscillations with a pulse power of up to 900 kW. Let us consider in brief the

principles of their operation.

A 220-V 400-Hz three-phase voltage applied to the transmitter input is stepped up several dozen times and is then converted by a rectifier into DC voltage. This voltage is used to produce a high-frequency high-power electromagnetic pulse.

The energy generated by the transmitter passes through an antenna changeover switch and is fed through a special cable to the feeds of the antenna upper and lower reflectors. Owing to the properly selected distribution of energy coming from the reflectors to the antenna, such a directional pattern is constructed that the bulk of energy radiated into space is spread along the earth's surface, thus ensuring the handling by the station of low-flying targets. At the same time such a redistribution of radiated energy (closer to the ground) reduces the ceiling of the P-15 radar scanning area and necessitates its use in combination with other radars which can cover medium and extreme high altitudes.

When the high-frequency energy radiated by the P-15 radar antenna into space meets an obstacle (a plane, a cloud, etc.) in its path, it is reflected from it in different directions. A small part of the reflected energy (echo signals) returns to the station antenna. It is necessary to pick it up, amplify it many times and discriminate the required information. This job is done by two important devices: the receiver and the indicator.

We should note that the P-15 radar station uses one and the same high-frequency channel to transmit both high-frequency energy from the transmitter to the antenna and target echo signals from the

antenna to the receiver. The antenna changeover switch serves to separate radiated high-power oscillations from low-power echo signals.

Low-power echo signals received by the antenna are fed through the high-frequency channel to the receiver input, then to the high-frequency amplifier and, after a number of subsequent conversions, to the station indicator.

The indicator's luminiscent circular screen displays a scale grid in the form of concentric circles (to read the range) and radial lines coming from the centre (to read the azimuth). Echo signals from the target also come ultimately to the screen and are represented there in the form of bright blips resembling small arcs.

Sometimes the P-15 radar is subjected to active or passive jamming. Active jamming is effected by a special transmitter installed aboard an enemy aircraft. The frequency of electromagnetic oscillations radiated by such a transmitter is equal to the station frequency. In that case the radar will receive direct rather than reflected signals. These signals are observed on the screen as bright closely located radial lines which "absorb" target blips. To avoid active jamming, the P-15 radar incorporates a special system which allows switching over to reserve frequencies. As soon as such lines appear on the indicator screen, the operator quickly changes over to another frequency by depressing the frequency switch button (the switch-over takes several seconds), after which the blips from the enemy jammer disappear.

The enemy can also use passive jamming by ejecting, with the use of a special dispenser, metallised strips from the aircraft. The length of these strips equals that of the electromagnetic wave radiated by the radar or half (sometimes a quarter) of its length. When striking these strips, the electromagnetic energy is reflected back to the radar producing bright blips on the screen (the same as when active jamming is used but of a different form). To reject passive jamming the operator switches on a passive jamming protection system available in the P-15 radar station.

The range at which low-flying targets can be detected depends on the height of the radar antenna. Therefore, the P-15 radar is usually deployed on hills or man-made hills. Besides, the antenna itself is mounted on masts several dozen metres high.

...The radar antenna is rotating smoothly. Every instant new and new pulses of high-frequency energy are sent

into infinite space at preset intervals. Having encountered a target on their way they are reflected from it and return to the station, carrying, in any weather conditions and in spite of any electronic countermeasures used by the enemy, the required information about the enemy aircraft.

A continuous stream of information is flowing from P-15 operators and operators of other stations to the command post. Because of this the command always has a complete set of data on the air "enemy" and at any moment can order fighters to take off to intercept "enemy" aircraft or to launch a missile capable of destroying any aerial target.

COPYRIGHT: "Soviet Military Review", 1984

CSO: 1812/157

ARMED FORCES

MILITARY MEDICAL SUPPORT SERVICES DEFENDED

Moscow SOVETSKIY PATRIOT in Russian 26 Mar 84 p 3

[Interview with Chief of Central Military Medical Directorate, USSR Ministry of Defense, Colonel General of Medical Service F. I. Komarov, conducted by V. Voronetskiy: "Concern for Soldiers' Health"]

[Text] Dear Editor. Six of my sons are serving in the Soviet Army. Things are going well with them and the lads don't complain about their health. But recently there have been rumors that things are not right with the medical support to our Armed Forces. Could your paper explain how it is organized?

Z. Semenova, city of Tambov

The editor asked the Chief of the USSR Ministry of Defense Central Military Medical Directorate, Colonel General of Medical Service F. I. Komarov, to answer our reader's questions. His conversation with our correspondent is published here.

[Question] Fedor Ivanovich, what do you think provoked these rumors the letter's author is writing about?

[Answer] These rumors are being leaked from abroad. Recently bourgeois propagandists have initiated an unprecedented campaign hoping to discredit the Soviet Armed Forces in the eyes of America and the world community. The USA administration headed by R. Reagan is setting the tone of this campaign. And medical support for Soviet soldiers has not missed their "attention." Not long ago a certain A. Cockburn maintained in the American magazine HARPERS that soldiers and sergeants in the USSR are not receiving medical care. He said that many illnesses have spread among them. Numerous Western "radio voices" are also making a fuss about this.

Clearly these statements are false. Everything, as they say, was made up. The USSR's successes in the area of health care are known worldwide. The Communist Party and the Soviet government consider care for the health of our people one of its most important social tasks. Favorable conditions for military medical support have also been developed in the army and navy.

[Question] Please give us more details on medical care for servicemen.

[Answer] Physically hardened, healthy young people join the army and navy and medical boards carefully examine every young person before call-up. To maintain the health of servicemen and to treat them in case of illness, we have an effective system of medical support. The unit or ship aid station is the center of this system in the forces. Medical personnel do everything to keep servicemen healthy. If a soldier or sailor is sick or injured, he is given timely and qualified medical aid where he is located, be it in a remote garrison, a state of operational readiness or on a sea cruise. And if more experienced specialists are needed, the patient is sent to a medical battalion, a hospital, to one of the central military hospitals or to a clinic of the military medical academy. After recovery, the serviceman can be placed into a military sanitarium if necessary.

Concern for improving the quality of medical support for the force is now gaining special significance. In the last 10 years our Armed Forces have changed radically. Military work and personnel combat activity have become more complicated. This requires servicemen to be in excellent health and have considerable physical strength, great psychological and emotional stability and the ability to act confidently in a tense situation.

The health of servicemen thus becomes a major element of troops fighting ability and combat readiness. We take all this into consideration when we organize medical support for servicemen.

[Question] Where is this work leading?

[Answer] There is also work and living condition sanitation. And sanitary inspections of the billeting, feeding, and watering of troops, their bathing and wash house accommodations. We are also developing scientifically founded hygienic norms which regulate combat training and military work.

We are placing a lot of attention on a comprehensive study of servicemen's health and are observing its dynamics. This gives us the ability to detect diseases as early as possible and to take the necessary medical-sanitary measures in a timely fashion. A dispensary system is widely used.

The latest methods for diagnosing and treating diseases are being implemented. Modern apparatus, equipment and instruments are being mastered. Highly effective drugs with either a wide spectrum of use or a required applicability are being applied.

Finally, measures for providing sanitary-hygienic and epidemiological well-being of troops and locations for their distribution are being systematically set up. This gives us the capability of preventing or significantly lowering the infectious sick rate.

[Question] As is evident from what you have said, a lot is being done. What results has this work produced?

[Answer] The results are totally satisfying. In the past 5 years the total morbidity rate for personnel in the Armed Forces has dropped 17.5 percent and the work time loss is down 7 percent. Discharges for sickness have dropped significantly and a reduction in the morbidity rate has occurred in all basic illness groups. The present health indicators for personnel are the highest in the whole post-war period.

New perspectives in the development of Soviet health care were determined by the adoption of the CPSU Central Committee and USSR Soviet of Ministers resolution on "Additional Measures for Improving the Health Protection of the Population." A long-term, complex program for maintaining and improving the health of army and navy personnel has been developed in the Armed Forces founded on the basic principles of this document.

12511

CSO: 1801/275

## ARMED FORCES

### ROLE OF SERGEANTS AND WARRANT OFFICERS CITED

Moscow KRASNAYA ZVEZDA in Russian 20 Mar 84 p 1

[Editorial: "Thoughtfully Teaching Sergeants and Sergeants Major"]

[Text] Sergeants and sergeants major, the largest section of the command structure in the army and navy, have an important role in resolving Armed Forces missions. They are active aides for officers and army and navy warrant officers in training and indoctrinating subordinates, in organizing socialist competition and in the struggle for strict military discipline and regulatory order. They have a large role in modern battle. The results of military training and the state of affairs in subunits, units and on ships depend a lot on how confidently they command squads, crews and combat posts.

In order to complete the duties entrusted to them, sergeants and sergeants major must have all the qualities of a commander-indoctrinator, including high ideological-political tempering, the necessary methodological skills, excellent professional training, the ability to correctly build the inter-relationship with subordinates and to get them to absolutely adhere to the requirements of the military oath and regulations. Firm junior commander authority, their personal example in completing their military duty and their observance of moral-ethical norms of conduct have great significance.

It goes without saying that all this doesn't happen by itself and it doesn't come with the duty assignment. Many years of experience and life itself convinces one that the art of training and indoctrinating subordinates must be purposefully taught to sergeants and sergeants major on a daily basis. They must also have thoughtful help and support. At the same time commanders and political workers must keep firm control over their service activities. In those units where this is done and where there are good conditions for training and improving their command, methodological and professional skills, where officers don't watch over them unnecessarily and do not substitute for sergeants and sergeants major, they have significant success in training and indoctrinating subordinates.

For example, we will refer to the experience of the excellent SAM unit commanded by Colonel Yu. Orlov. This unit is actively and completely using all forms and methods of training and political, military, moral and legal indoctrination for junior commanders that are warranted. Sergeants' days,

instructor-methodological and show exercises are being conducted at a high level, well organized and instructively. Commanders and political workers are constantly watching sergeants' theoretical preparation and practical activity, and are analyzing their work in training and indoctrinating soldiers, their disciplinary practice and are advising them on how best to conduct lessons and maintain the spirit of competition in them. They are very concerned about the authority of junior commanders.

The foundation of sergeants' and sergeants' major command knowledge and skills is developed in the training subunits and units designated to train and indoctrinate future junior commanders in the areas of the modern development of military affairs and the increased demands made on their training. However, facts, including letters to KRASNAYA ZVEZDA, testify that matters are not like this everywhere. In some training subunits the effects of the training-indoctrination process are still minimal. Captain I. Kolodka writes the editor that "quite a number of young sergeants arriving in units turn out to be poorly prepared in training and indoctrinating soldiers." "Having poor methodological skills and without the rudiments of individual work with subordinates, they are lost in simple service situations and cannot find a reliable level of mutual relations with soldiers. Some sergeants lack exactingness and are influenced by disciplinary violators. All of this greatly lowers the training-indoctrination process."

Such facts are completely intolerable. We must reach the level where every training subunit organizes the training-indoctrination process in a model manner and is a real school for training skillful, fully knowledgeable junior commanders who demand high standards from themselves and their subordinates.

The most complicated, responsible period in a sergeant's or sergeant's major service activity is their development in units or ships. Here the advice and support of commanders and political workers is especially valuable. Now as winter military training is in full swing, there are good possibilities for improving field, air and sea training for sergeants and sergeants major and for improving their skills in leading subordinates in the complex conditions of the modern battlefield. It is worth giving their initiative and independence free rein.

Unfortunately, all sergeants and sergeants major are not enjoying the necessary attention of officers and army and navy warrant officers. Some commanders and political workers don't have the time to talk with a sergeant or a sergeant major, take an interest in how he is meeting difficulties and see what help he needs. Often these officers and warrant officers give soldiers orders and bypass their immediate supervisors. At times junior commanders are rebuked in front of a formation or in the presence of their subordinates and are severely judged for a slight error caused by inexperience or poor service knowledge. Such an attitude in no way enhances the development of sergeant and sergeant major authority and damages their overall development.

High ideological conviction and communist consciousness are an important foundation for successful sergeant and sergeant major activity. It is the

duty of commanders, political workers, party and Komsomol organizations to constantly improve ideological-indoctrination work with sergeants and sergeants major, to develop high political, moral and psychological qualities in them and to arm them with a thorough knowledge of decisions by the 26th CPSU Congress and subsequent CPSU Central Committee Plenums, Communist Party domestic and foreign policy, and missions of the Armed Forces, units and ships. Party and Komsomol organizations must set a personal example for sergeants and sergeants major in completing military duty and in reaching a point where every one of them actively participated in the social life of the military collective.

The daily training and indoctrination of junior commanders is an important contribution to the struggle for effectively organizing the training and indoctrination process, totally fulfilling social obligations and providing high combat readiness in units and ships.

12511

CSO: 1801/259

## GROUND FORCES

### MARCH POSSIBILITIES DISCUSSED

Moscow SOVIET MILITARY REVIEW in English No 3, Mar 84 pp 42-43

[Text]

March possibilities are taken to mean the ability of subunits to move by their own transport means from one area to the other at the fixed time while maintaining combat readiness. They depend on the manoeuvring, operational and combat qualities of vehicles, their technical condition, drivers' physical capabilities and training level, march training of subunits and the ability of the commanders to control columns on the march.

The main indices of the march possibilities are the average speed, the day's march distance and the overall length of the march.

The average speed of movement is the main index of making the timing for the march. It is determined for the day's march by dividing the quantity of the day's march by the planned time of movement, excluding the time allotted for halts.

The speed of movement on the march depends on the assigned mission, march training standard of subunits, condition of vehicles, quality of a route, weather, time of the year and the day and also on the organisation and security

of the march. The speed of movement on IFVs (APCs) and tanks, on vehicles moving in a separate column, on foot and on skis may vary substantially.

In mountains, deserts, northern regions, in marshy and wooded country and under other unfavourable conditions an average speed of movement can considerably slow down.

When subunits fulfil independent missions the speed of movement, as a rule, is higher.

In any case a march must be carried out at the maximum possible speed under the given conditions.

The day's march distance is the distance covered by a unit, subunit during a day. The day's march distance is defined by average speeds and by the duration of time of column's movement.

The overall length of the march is a distance in kilometres from the initial line (point) to the remotest point of a new area (line). It is defined on the map with a curvimeter or a measuring instrument with per cent correction of a route profile of the

march. Depending on the relief of a map and its scale this correction may come to 5-25 per cent.

In practice, when measuring a distance on the map the indicated corrections should be taken into consideration for each kilometre. It is wrong to add a total correction to the overall distance measured with the aid of the map's scale.

The calculation of the march begins during specification of a mission and is then carried out during the process of evaluating the situation and taking a decision. When timing a march the following data are defined: the overall length of the march, the time required for it, the average speed of movement and speeds on separate sections of the route, the time of passing the initial point, traffic control points and points of reaching the indicated area or line of the march security elements, place, time and duration of halts for march security elements and also for the column of the main forces if that was not indicated for them by the superior commander.

The total time of carrying out a march, including short halts, is the time difference between the end and the beginning of a march. The beginning of a march is the time of passing the initial line (point) while the end is the time of arrival in the appointed area or to the assigned line.

On separate sections the speed of movement may be lower or higher depending on the accidents of the terrain, quality of roads, weather conditions, etc. However, in any event it must reach the

average speed of movement on the march. Under all circumstances the time of passing the traffic control points defined by the superior commander must be strictly observed.

The total length of the march, the average time for carrying it out and speeds of movement are defined when sizing up the mission and specified when estimating the terrain.

The time of passing the initial point, the traffic control points and reaching the appointed area or assigned line by the elements of the security on the march is determined by the commander depending on the time established for the column of the main forces and also proceeding from the remoteness of the elements of the security on the march and the planned average speed of movement.

The places of halts are selected so that they would provide a reliable camouflage for the subunits, while the time of halts conform to the average speed of movement and the requirements of field manuals. If places and the time of halts for a subunit are indicated by a superior commander, then the subunit commander defines them only for the security on the march, taking into consideration its remoteness from the column of the main forces.

The time of passing different points and reaching the assigned area or appointed line, places and duration of halts are defined when the commander evaluates the situation and takes a decision.

## GROUND FORCES

### DESIGN, OPERATION TANK-ENGINE CLUTCH DISCUSSED

Moscow SOVIET MILITARY REVIEW in English No 2, Feb 84 pp 26-27

[Article by Colonel Engineer M. Starostin]

[Text]

The engine clutch, the tank's major unit, is intended to disengage the gearbox from the engine when starting the latter and changing gears, and to ensure the vehicle's smooth takeoff. For the engine clutch to work reliably, one must be well familiar with the peculiarities of its operation, maintenance and repair.

Friction disks employing the principle of dry friction between metal surfaces are the main components of the engine clutch. With the engine idling, the speed of the driving members of the disks is constant, and that of the driven members is equal to zero. When the clutch control pedal is depressed, the clearance between the friction disks is taken up, the latter come into contact, and the vehicle is set in motion. As this takes place, the speed of the driving members increases, that of the driven members is reduced, the disks slip for a few moments, and their speeds are gradually equalised. The shorter the slipping time, the less the disks are worn out. The minimum slipping time, however, is limited by impact loads on the transmission, arising in the event of quick cohesion between the revolving and stationary parts. Practice has shown that the optimum slipping time is 0.5 to 1.5 seconds. In severe road

conditions, it is practicable to start from a stationary position with the steering levers placed in first position.

When the vehicle is on the move, the engine clutch is used for gear shifting 5 or 6 times per kilometre of run on the average. This, naturally, is conducive to wear-out of the disk with the resultant malfunctioning of the clutch, e.g. frequent slipping of the latter with the control pedal fully depressed.

Drivers are well aware of the fact that the most characteristic sign of engine clutch slipping is a discrepancy between the tank's road speed and engine rpm on difficult sectors of the terrain, where the engine torque is at its highest. Engine clutch slippage may also be caused by worn-out friction disks, which results in a reduced thickness of the constituent plates and, consequently, in a smaller clearance in the clutch release mechanism. With heavily worn-out disks, the above clearance is non-existent altogether. Releasing the pedal in this case does not allow the effort of the clutch springs to be fully utilised, owing to which the maximum torque transmittable by the clutch is decreased.

To avoid this, drivers should perform periodic checkups of and restore the clearance in the clutch release mechanism to the normal value, i.e., 1.8-2.1 mm.

The clearance in the clutch release mechanism allows free travel of the clutch control linkage, this travel being proportional to the clearance. Therefore, an increase or decrease in the free travel can be achieved by lengthening or shortening the clutch control rod. The normal free travel of the longitudinal rod is 7-9 mm, and its minimum and maximum values, 3 and 11 mm respectively.

When measuring the free travel of the longitudinal rod, it should be borne in mind that its value depends on the clearances in the clutch release mechanism and the control linkage joints. A heavily worn-out linkage is likely to bring about an error in assessing the clutch's condition. Therefore, checkups of the clearance on tanks which have run 3,000 km is performed by measuring the play of the clutch release yoke, with access gained through the port under the engine clutch in the tank bottom.

Slippage of the engine clutch may also be attributable to oil getting onto the friction disks. If so, the latter should be washed with gasoline. Another negative factor affecting engine clutch service life is incomplete disengagement of its driving and driven members with the clutch pedal fully pressed down. This trouble is likely to result in a failure of the gearbox synchronising units.

There are several reasons for incomplete disengagement of the engine clutch, e.g. decreased travel of the pressure plate; warped, broken or contaminated disks; foreign objects under the rod; or maladjusted servosprings.

The travel of the pressure plate is measured with the aid of a ruler, which is thrust through the hole in the engine clutch flange. The rated value should be 7 to 8 mm. If this value falls beyond the rated one, the travel of the clutch pedal is increased by turning out its lower thrust bolt.

If disks are warped, only individual portions thereof contact each other, which leads to metal over-

heat and further change in the disk shape. To avoid warpage, the disks should be protected from overheating. If this proves impossible, the engine clutch should be disassembled, friction disks cleaned and washed, and unserviceable disks replaced.

Insufficient tensioning of the servospring will make depressing the clutch pedal very difficult. An overtightened spring may cause incomplete engagement of the engine clutch or otherwise affect the normal functioning of its control linkage. To check tensioning of the servospring, the engine clutch control linkage return spring should be detached and the pedal depressed until the adjusting bolt thrusts against the bow armoured plate. A correctly adjusted servospring will return the released pedal to the initial position (till the upper adjusting bolt thrusts against the armour) easily and without a bump.

If the pedal fails to return to the initial position, or its return is accompanied by a bump, tensioning of the servospring should be properly adjusted. In doing so, the driver depresses the engine clutch pedal until the lower bolt thrusts against the armour, and tightens the servospring in such a way that the pedal remains depressed after his foot has been removed from it. He then slackens the spring until the pedal returns to the initial position properly. This done, he checks the clutch control linkage for correct functioning by alternately engaging and disengaging the engine clutch two or three times.

Also, the engine clutch control linkage should be systematically checked for serviceability and adjusted, if need be. To this end, the driver depresses the clutch control pedal until the lower bolt thrusts against the armour plate, and measures the clearance between the stop and the electric button cap, which should be 0.5-1 mm. If the clearance falls beyond the indicated value, it should be adjusted by displacing

the stop. After this, operation of the electropneumatic valve should be checked with the pedal depressed.

Observing the above recommendations will help prevent typical failures of the engine clutch, one of the most heavily loaded units of the tank.

**Measuring the longitudinal rod free travel**

1. Initial position
2. One-way free travel

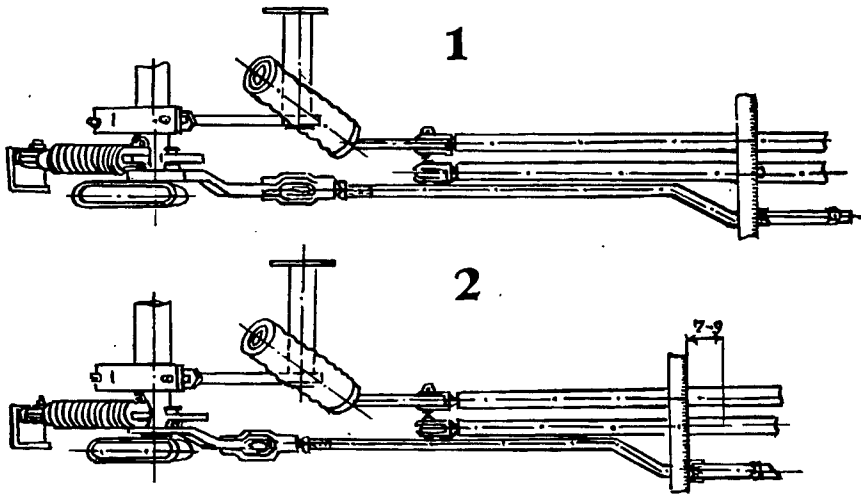

COPYRIGHT: "Soviet Military Review", 1984

CSO: 1812/157

## GROUND FORCES

### AMPHIBIOUS TANK TRAINING EXERCISES EXAMINED

Moscow SOVIET MILITARY REVIEW in English No 2, Feb 84 pp 28-30

[Article by Captain A. Kondrashov: "Thus Comes Fearlessness"]

[Text]

Once during an exercise the marines were ordered to capture a beachhead. Though the mission was quite typical for them, it had to be executed in unusual conditions. To take the "enemy" unawares, it was decided to land the force in stormy weather.

The men looked at the turbulent waves with apprehension. The drivers of amphibious tanks were particularly troubled, for they never had had to operate in such a storm.

Senior Seaman Nikolai Katsuba, the most experienced driver in the subunit, realised better than anybody else that they would have it tough during the landing.

"Let me go first," he asked the commander. Permission was granted.

"Go, men!" came the command at last.

The huge gates slid apart heavily. Nikolai Katsuba's tank was the first to roll down the ramp and plunge into the stormy sea. He was followed by other vehicles.

Driving the PT-76 tank on land is a real pleasure. But it is not so easy on the high seas. Nevertheless, the vehicle driven by Katsuba made for the shore steadily, its crew conducting a well-aimed fire on the move.

The combat training mission was fulfilled.

For courageous actions during the exercise many marines were commended by the command.

Taking an interest in these gallant men, I visited the battalion where Nikolai Katsuba served. I familiarised myself with the various aspects of the marines' combat training and the system of psychological steeling.

It is no easy job to develop a habit for courageous and gallant actions. The whole process of instruction and all forms of educational work are focussed on this task. Realising that ideological convictions are the basis for lofty moral and political qualities, the subunit's command pay a great deal of attention to political education.

A marine must act with equal skill both on land and at sea. This skill is developed by daily training, which includes special exercises and methods of psychological steeling. Let us touch upon some of them.

**Rolling into a tweendeck.** At first sight this exercise seems rather easy to do. But for a young driver it is quite a problem: he has to drive the tank across a flap of a collapsible metal bridge and position it at a

strictly predetermined location. This requires not only skill, but also poise and courage — qualities Nikolai Katsuba lacked at the beginning of his soldiering.

He still remembers an embarkation which took place in those distant days. Praporshchik M. Martynenko was the first to drive his APC across the bridge and on into the tweendeck. Nikolai Katsuba's tank, which was following him, decelerated sharply and came to a standstill. The other vehicles had to stop too.

Nikolai stuck his head out of the tank:

"I can't handle it. I'll bump the ship."

Realising that the young driver would not surmount the psychological barrier on his first try, Praporshchik Martynenko took his place at the controls, and fulfilled the assignment himself. After the exercise he stayed behind with the novice. The two measured the bridge width and the tweendeck height, and compared the measurements with the overall dimensions of the tank. It turned out that there still remained a gap between the tank and the ship.

However, it took Katsuba some time to overcome his constraint. He had additional training on a special mockup, representing a model of a landing ship. Again and again he worked up the technique of driving the tank into the tweendeck. Finally he made it, gaining confidence in his abilities. During a subsequent embarkation he performed on a level with the unit's best specialists.

**Leaving a submerged tank.** A tank is placed in a basin, and the crew take their action stations. Water is then turned on to fill the basin and flood the vehicle. The tankmen put on isolating gas masks, and stay at their places. They are to remain under water for a certain time, and then to leave the flooded vehicle on the commander's order.

Nikolai Katsuba's crew was fulfilling the exercise. The tankmen stayed under water, patiently waiting for the next order. All of a sudden a young sailor dashed for the manhole and came to the surface in an instant. That was Alexander Dudin, the loader. He said he was suffocating down in the tank, that something was wrong with his gas mask.

Senior Seaman Katsuba understood at once that the gas mask was not to blame. The novice had to overcome fear and gain confidence. Nikolai suggested that they exchange gas masks. The crew again took their places in the tank. This time Dudin was more sure of himself.

**Fire course.** On the face of it, it is an ordinary obstacle course with a 3-m deep ditch, a labyrinth, a high fence, a mockup of a semi-destroyed building, a wire entanglement, and an assault bridge. But when the course is enveloped in smoke and flames, it takes some doing to get over it. More than once did Nikolai Katsuba and his comrades — Seamen Anatoly Blyznyuk, Oleg Pakut and other marines — wash burnt eyelashes and treat bruises with iodine after a fall. However, there has never been a single case of serious injury on the course, as safety measures in the subunit are strictly observed.

**Storm ladder.** The marines borrowed this exercise from the sailing fleet. In olden times sailors had to climb rope ladders to dizzying heights, thereby developing fearlessness and adroitness. Soviet marines today use the storm ladder to develop the same qualities.

Nikolai Katsuba told me that it took his breath away when he climbed a swinging rope ladder for the first time. That time he was helped

out by experienced servicemen Viktor Khomchenko and Vladimir Stankevich. They showed him how to "break in" the "dancing" rungs, where to look and how to regrasp.

Nikolai has climbed kilometres of storm ladders since then, and now he himself helps novices do this exercise.

"Rock of courage." It takes a real man to hook one's waistbelt to a wire rope and jump into the sea from a high rock. Just like before a parachute jump, even the most daring men cannot help feeling a little nervous. Nikolai Katsuba and his comrades are not afraid of jumping, for they have had a lot of intensive and purposeful training.

The system of psychological steeling for marines includes numerous elements of paratroopers' training. Like paratroopers, they can jump from an aircraft, for instance. In Katsuba's battalion each sailor has ten or more parachute jumps to his credit. As to the officers, they have many more of them. Thus, Major N. Anzigitov has made 200-odd

jumps, and Senior Lieutenant Yu. Alexandrov, 250.

The marines' psychological steeling also includes exercises and techniques taken from the motorised infantry training system, e.g. grenade throwing, "rolling over" by tanks, and attacks following a barrage of fire, which also helps develop courage, gallantry and fearlessness.

COPYRIGHT: "Soviet Military Review", 1984

CSO: 1812/157

AIR/AIR DEFENSE FORCES

DEPUTY REGIMENTAL COMMANDER FOR POLITICAL AFFAIRS PROFILED

Moscow SOVIET MILITARY REVIEW in English No 3, Mar 84 pp 46-47

[Article by Colonel Yu. Nikitin: "On the Ground and in the Air"]

[Text] The tactical air exercises started late at night. The crews at the command post were extremely busy. Lieutenant-Colonel V. Sazonov, deputy regimental commander for political affairs, Major V. Dosyukov, secretary of the Party committee, and Senior Lieutenant of Technical Service G. Rabetsky, secretary of the YCL committee, quickly distributed the assignments.

Lieutenant-Colonel V. Sazonov told the regimental commander:

"I shall tour the stations of the subunits together with them."

The regimental commanding officer gave his approval, saying:

"While I am briefing the flyers, it would be good to conduct a short talk with the men and mobilise them."

The silvery covering of the bombers had a dim gleam. The men were invisible in the dark. Only the beams from the flashlights showed that the ground crews were servicing the fighting aircraft. The engines of the fuel trucks were humming. Other special vehicles were also doing their work. The vari-coloured lights on the runway were like a garland on the ground. After many years of service in the Air Force Vladimir Sazonov was familiar with the picture. It had purpose and meaning, it invariably evoked excitement in all Air Force servicemen.

He developed a love for the air at secondary school. Lev Borodin, deputy director of the school, was a former squadron leader. He frequently told the boys and girls about the noble and courageous profession of flying. The reserve officer did not confine himself to talks. He entertained the idea of organising a parachute jumping team at the local air sports club. The city Party committee supported his initiative. After a series of lectures and lessons on theory Vladimir and his classmates each performed three jumps. Many of the graduates, including Vladimir Sazonov, went to study at military flying schools to become professional flyers.

The years of study were now a thing of the past. Lieutenant-Colonel V. Sazonov now recalls with gratitude Lev Borodin and also flying instructors Captain P. Konichenko and Lieutenant A. Karev, who made a competent flyer out of him.

Vladimir Sazonov was a flight instructor himself for several years. This period enabled him to improve both his knowledge and skills. He became proficient in military pedagogy and psychology, which were essential for training flyers.

Captain V. Sizov, deputy squadron leader for political affairs, reported to Lieutenant-Colonel Sazonov, as soon as he appeared at the squadron station.

"Is everything all right?" the senior officer asked.

"All procedures are being carried out according to plan. There are Party activists in every technical crew. I am certain the proficiency requirements will be met."

When the ground crews prepare the bombers for a mission, they cannot afford to waste a single minute. In these circumstances Lieutenant-Colonel Sazonov finds various ways to boost the men's morale. If necessary, he will give a piece of friendly advice, say a word of approval to the most efficient men or reproach those showing poor performance. Seeing that everything here was under control, the deputy regimental commander proceeded to the station of another squadron. Everything was in good order there too, so he returned to the command post.

The regimental commanding officer was still briefing the officers. He said:

"The orders are to deliver an attack on an 'enemy' airfield. Your mission is..."

Vladimir was all ears now, because he was to lead the group. It was a formidable mission. It was necessary to make the approach at a low altitude and to force their way to the target through a strong anti-aircraft defence system to accomplish the bombing mission. After that the pilots were to execute a difficult air manoeuvre.

The entire mission was modelled in very little time. The experience the crews had accumulated and their complete understanding were very helpful here. The calculations having been carried out and documents put in order, Lieutenant-Colonel V. Sazonov reported to the commanding officer on the readiness of his group.

In a short while the bombers soared into the dawning sky. The leader confidently piloted the heavy machine, the navigator reporting on the changing flying conditions. The wingman held his position well. Suddenly the radio-operator gunner reported:

"'Enemy' fighters approaching for an attack from the starboard quarter."

"Beat them off," Sazonov said putting the bomber into a right turn.

The "enemy's" attempt was foiled, but the leader had to be on the alert. He issued a warning to the crews:

"Be on the alert."

"'Enemy' attacking from port quarter," the radio-operator gunner reported.

The bomber executed another manoeuvre and then another. The bombers were winning a difficult engagement. Finally, the fighters abandoned pursuit. They were apparently short of fuel. Lieutenant-Colonel V. Sazonov changed the course till the next turn. During this lap he altered his speed, height and direction several times. The purpose was to mislead the "enemy." After that he performed an ascent to put the machine into the combat course.

The "enemy" was taken by surprise. His antiaircraft weapons failed to offer stiff opposition to the attackers.

The target--a fuel depot--was hit during the first approach. The forward crews destroyed the "enemy" aircraft on the ground and badly damaged the runway. The airfield was put out of action for some time. Having executed the final manoeuvre, Sazonov proceeded to his base.

When Sazonov reported to the regimental CO on the accomplishment of the mission, the latter gave him a hearty handshake and congratulated him. He said:

"Well done, commissar. The report from the bombing range says you scored excellent hits on the targets. The other groups have accomplished their missions too."

Sazonov lost no time in finding Major V. Dosyukov, secretary of the Party committee, and Senior Lieutenant G. Rabetsky, secretary of the YCL committee. He instructed the former to get the crew commanders, navigators and flight engineers who distinguished themselves to address the flyers. At the same time Sazonov told the latter to see that the combat leaflets were put out in time. The deputy commander himself decided to check fulfillment of the plans for Party-political work in the squadrons.

Ten years before the senior officers saw that Vladimir Sazonov, then a young officer, had the gift of leadership and organisation. They observed that he was willing to work with the men and could inspire them. Vladimir Sazonov was then appointed deputy squadron leader for political affairs.

He accepted the new appointment with enthusiasm. The then deputy regimental commander, Lieutenant-Colonel Stantsenko, helped him with timely advice. Without unnecessary tutelage the senior officer taught Vladimir to plan his

work, to concentrate his efforts on the main element and to see that the plans were fulfilled.

Other senior comrades also helped the young officer. Colonel G. Azbukin, deputy chief of the political department, had regular talks with him, too. Once he suggested to Sazonov that he enter the Lenin Military Political Academy. Vladimir decided to enter the correspondence department.

Studies called for additional effort. In the daytime Sazonov was at the airfield or headquarters and in the evening he was pounding the books. When Sazonov was in his second year at the Academy, he learnt that he was being promoted. He was afraid he would not be able to cope with the new job. When he spoke to the regimental commander about his doubts, the latter said:

"We have a good collective, and you are strong. We will help you. I shall see to it myself."

"We have been working with the commanding officer hand in hand for five years now," Lieutenant-Colonel V. Sazonov says.

Speaking about him, the Chief of the Political Department of the Military District Air Force said:

"Sazonov is an expert planner. When he goes to a subunit he knows in advance what he is going to do. And he has taught his officers to work in the same fashion."

The unit has not had any air accidents for quite a long time. It has retained the title of excellent unit for five years. In the last few years there have been many improvements in the living and working conditions of the officers and men. The cantonment has been rebuilt. One of Sazonov's personal achievements is that he has accomplished the programme of military pilot 1st class. Despite this, Sazonov is concentrating his effort on problems that yet have to be solved. That's the way he's made. He is never satisfied with what he has achieved.

One of his distinguishing traits is that he will always establish the root cause of a phenomenon and will organise help for others.

It is impossible to state all the responsibilities and problems this deputy regimental commander for political affairs has to cope with every day. He is both a pilot and educator. He has made a sizable contribution to the success of the military collective he serves in. Vladimir Sazonov, political worker, has been awarded the Order "For Service of the Motherland in the USSR Armed Forces, 3rd Class."

COPYRIGHT: "Soviet Military Review", 1984

CSO: 1812/158

## AIR/AIR DEFENSE FORCES

### POOR PERFORMANCE EXPLAINED

Moscow KRASNAYA ZVEZDA in Russian 10 Mar 84 p 2

[Guards Lieutenant Colonel S. Solarev: "Hoping for a Work Detail"]

[Text] The third month of winter training is over. All this time the third squadron has been the regimental leader in competition under the slogan "Be always on the alert and ever ready to defend socialism's achievements." It is heartening that the outstanding collective goes confidently toward its designated goals. And last place, once again taken by the squadron commanded by Guards Major A. Kuz'kin, saddens one. Such "constancy" of the subunit causes one to reflect.

One remembers the end of the last training year. It brought no satisfaction to Guards Major A. Kuz'kin's subordinates. They did not meet their responsibilities and the squadron was not rated outstanding. And the goal was realistic.

Sharp criticism was leveled at squadron communists during the regimental communist electoral meeting. Specifically, they noted that the squadron did not strictly demand that communists fulfill their party and service duty and that the party buro didn't always evaluate each violation of rules for servicing aviation equipment. The squadron was ordered to help organize competition and aircraft servicing. In short, a lot was done so that the aviators could correct the situation and return the collective's good name in the new training year.

It seemed that this would happen. At the summer training period squadron personnel took high responsibilities. Many pilots and technicians promised to take noticeable steps in military improvement and to increase their professional preparedness, class qualification and to eliminate potentially dangerous conditions in flight activity. But as is known, high standards in competition do not come about by themselves. To conquer them one must work intensely every day. Unfortunately, as facts show, the squadron forgot about this truism.

Not long ago regimental staff inspected the state of aviation equipment in subunits. Frankly speaking, the picture that the inspectors saw wasn't very pleasant. Deficiencies were uncovered in pre-flight inspection and aircraft

preparation sections. These were the responsibilities primarily of Guards Senior Lieutenants of Technical Service A. Vavshik and N. Astashev. And on the sides of the combat machines serviced by them was painted the slogan "outstanding airplane."

Certainly this fact alone is unpleasant. And not only because squadron personnel accepted high socialist obligations and had still hardly taken the necessary steps toward meeting these obligations. The strange attitude of the squadron commander and secretary of the party buro Guards Senior Lieutenant V. Vorob'yev and other communists towards this is surprising. True, talk about improving the quality of aviation equipment servicing and the necessity of expanding technician and mechanic knowledge has been heard at many party gatherings and buro meetings. But things have not progressed beyond conversation. It is apparent that they have forgotten the reasons for their earlier failures.

The squadron is not properly analyzing the experience of using and servicing aviation equipment and personnel are guilty of not critically evaluating each incident of potentially dangerous flight activity. And the squadron commander's assistant for engineer-aviation services, Guards Captain of Technical Service V. Kozadoyev, has no small part of the guilt in this. He controls the flow and quality of aircraft preparation poorly and is not always concerned about disseminating the latest experiences of the best technicians and mechanics. And there are many such good specialists in the subunit. For example, take aircraft technician Guards Senior Lieutenant of Technical Service V. Romanenko. This officer always conscientiously completes his duties and there have been no instances of equipment failure or potential problem areas for flight activity that have been his fault. And it is no accident that the plane which Romanenko services has been rated outstanding for several years. The officer's work record undoubtedly deserves attention. But Guards Captain of Technical Service Kozadoyev doesn't care about summarizing and disseminating it. Yet members of the party buro have not helped him on this project either. And working right along side Romanenko on aircraft stands are Guards Senior Lieutenant of Technical Services V. Shvedov and other technicians who allow mistakes and errors in servicing equipment.

After the aviation unit inspection, the squadron commander's political unit assistant, Major V. Chuyev, was heard to optimistically say the following. "We have time to correct matters. The end of the winter training period is still a long time away and we have enough time to eliminate the shortfalls."

Is there ever enough time? Will the results of the last training year be repeated? It will be difficult to make up at the end of winter training the things which are allowed to slip by now. And no all-hands work detail will help at the end. They ought to pull in the slack immediately.

12511

CSO: 1801/266

## SPECIAL TROOPS

### RAILROAD TROOP COMMANDER PROFILED

Moscow KRASNAYA ZVEZDA in Russian 20 Mar 84 p 1

[Senior Lieutenant A. Vorob'yev, part-time KRASNAYA ZVEZDA correspondent, Eastern Baikal-Amur Magistral Section: "Devotion to Duty"]

[Text] An officer's service in railroad troops is very unique. Combined in this service and closely interwoven are the features both of an experienced military and a transportation construction worker. The commander of railroad troops not only trains and indoctrinates soldiers. He also manages production. And he must solve these missions under circumstances when, as a rule, he has to start from scratch in inhospitable locations without roads and good living conditions. This requires a special dedication to duty, ideological maturity, human durability, initiative and selflessness in work.

And for almost 10 years already, Colonel I. Roman'kov has been serving where the route of the eastern portion of BAM [Baikal-Amur Main Line] is being built. In February 1975 a mechanization battalion which he commanded arrived at the foot of the Dusse-Alin' Range as part of the first railroad troop subunits. Here among the rocky knolls they were faced with building part of the main line and the Nal'da station.

And specialists, after learning how fast the battalion commanded by officer I. Roman'kov completed the task, are still surprised by the commander's daring engineering solutions and the persistence of his subordinates. The soldiers-railroad troopers contrived to lift bulldozers and excavators to 700 meter elevations to speed up the development of the notches cut in the folds.

The precise calculations and skills of the battalion commander in inspiring troops and leading them in what seemed back-breaking work led to success. He relied on the support of communist and Komsomol members in this. And everyone will remember that he himself directed the first cut in the rocks which on Roman'kov's suggestion was done with controlled explosions.

In the years that followed, under the leadership of Ivan Ivanovich Roman'kov the railroad soldiers-troopers reached many labor victories and built many kilometers of main line. They laid it through fog, swamp and rock. The scale and volume of tasks which Colonel I. Roman'kov now solves have increased

immeasurably. He generously shares his experiences with young officers. His subordinate majors A. Sivak and M. Morozov have become skilled battalion commanders and not long ago both were awarded the order "For Service to the Motherland in the Armed Forces" 3rd class. The battalions they command have almost fully mechanized road work.

Not long ago, while discussing the way for resolving missions assigned by the party, fulfilling labor productivity 1 percent above and beyond the plan and additionally reducing construction costs 0.5 percent, communists of the travel battalion commanded by Major G. Gurskiy adopted their own counterplan. They undertook to build additional lines to the Tangomen, Kamnega, Tungala and Miroshnichenko stations. These obligations, which were accepted in addition to the strenuous plan, are also to some degree a result of the single-minded work done by Colonel I. Roman'kov in developing modern economic thinking in each officer.

The railroad soldiers-troopers who are building the eastern portion of BAM are working under harsh conditions. And this demands especially great efforts from the commander in organizing normative work and living conditions for servicemen, their families, workers and employees of the Soviet Army. At the suggestion of Colonel I. Roman'kov and through his persistence each unit now has warm-up cubicles for equipment repair right at the tracks and field cantonments. According to Ivan Ivanovich the problems of life style on BAM are primarily political. He spares neither time or effort in resolving them. And people go to him for advice and help not only in his capacity as commander and senior comrade. He is also deputy of the local soviet of people's deputies. People know that they will always find support and understanding from this man.

Very little time remains until the rails meet in the eastern portion of the main line. On 9 May at the Miroshnichenko Station the final "golden" link will be laid. Colonel Roman'kov awaits this day with special excitement. Colonel I. Roman'kov, one of BAM's first trailblazers and holder of the order "For Service to the Motherland in the Armed Forces of the USSR" 3rd class has selflessly labored for 10 years for this day, overcoming all difficulties.

12511

CSO: 1801/266

## SPECIAL TROOPS

### TRAINING FOR RAILROAD TROOPS DESCRIBED

Moscow SOVETSKIY PATRIOT in Russian 11 Mar 84 p 3

[Article by Sr Sgt V. Ol'shevskiy, Frunze scholarship holder: "The Steel Lines Are Calling"]

[Text] I was frequently asked the question why I decided to become a military railroad worker--at the rayon military commissariat, then before the entrance examinations and finally at the credentials committee before they announced that I had been enrolled as a student of the Leningrad Order of Lenin Higher School of Railroad Troops and Military Communications imeni M. V. Frunze. I answered without hesitation. Back in the 8th grade I had firmly decided to go to a military school. True, then I had not yet determined exactly to which one.

In school I gave much attention to algebra and geometry, physics and history. I took an interest in initial military training, was involved in sports and worked actively in the DOSAAF primary organization. I knew that all this was simply necessary since I had decided to become an officer.

One day I read a notice in KRASNAYA ZVEZDA concerning enrollment into the School of Railroad Troops and Military Communications. Before this I did not even know that such a school existed. I had heard nothing at all about the railroad troops, although you could say that ours was a railroad family. My father worked as a foreman on the railroad and my sister attended the Leningrad Institute of Railroad Transportation Engineers.

My hometown Baranovichi is the major railway junction in Belorussia and, of course, conversations on the subject of railroads occurred quite frequently in our family. "I shall become an officer in the railroad troops," I decided. My father approved of my choice.

Only later, when I was already in the school, did I truly find out about the glorious traditions and important tasks of the railroad troops in the war and during peacetime. These troops are intended for restoration, construction, operation, obstruction and technical protection of railroads used for military traffic.

Our school's history and its combat traditions are remarkable. It dates back to the Great October Revolution. In 66 years it has covered a glorious and

industrious path and has trained thousands of officers for the railroad troops and military communications agencies of the Soviet Armed Forces. Students of the school took part in suppressing the counterrevolutionary Kronstadt revolt. The school was awarded the Honorable Revolutionary Red Banner of the All-Russian Central Executive Committee.

Students exhibited genuine heroism in August 1941 by containing the enemy at Luzhskiy line after he had broken through to Leningrad. After the defeat of the Hitlerites at Moscow, the students restored the railroads at Volokolamsk, Mozhaysk, Maloyaroslavets and Tula.

After the breakthrough of the blockade in 1941, locomotive crews manned by our students transported the wounded from Leningrad along a narrow corridor under bombings and concentrated artillery fire and supplied the besieged city with food, ammunition....

Now the officer-alumni of the school are laboring on some of the key construction projects of the Motherland, above all on the Baykal-Amur Trunk Line. Here 16 officers became Leninist Komsomol prize laureates and Lieutenant Colonels S. Pal'chik and V. Kupriyanov were awarded the title of Hero of Socialist Labor. And we are being compared to them.

...Now my dream has come true. I received excellent marks on the entrance examinations, passed the physical training and met a strict medical board. I began studying the bridge specialty, a complex and very essential specialty for the railroad troops.

It was not easy to get used to military discipline, to learn to walk at attention under the mercilessly broiling sun or in the rain, to fire an automatic weapon accurately, to throw a grenade at a target and to run out to physical exercises during any weather.

Then came the oath of allegiance to the Motherland and the training days began.... At first there were failures and there were joys also. Several months passed and I could no longer imagine how I lived before without a firm daily routine.

Time flies.... The first three years of study passed unnoticeably. You look now and again at your classmates and catch yourself thinking: we have learned much during this period, grew up and became more serious. Now we are capable of solving engineering problems and commanding a platoon.

I have many good friends. Sr Sgt Sergey Voronov--course master sergeant, Sgt Aleksandr Nechaev--member of the Komsomol Buro, Sr Sgt Dmitriy Sumin--deputy platoon commander and Sgt Sergey Klochenko, whose platoon has been excellent for 3 years, have been studying excellently for 3 and 1/2 years and participating actively in public work.

Looking back, I recall with warmth in my heart that day the Komsomol members of the course showed their trust in me and elected me as delegate to the 29th Komsomol Congress. In the third year I was elected secretary of the Komsomol Buro and people's assessor of the garrison's military tribunal.

Indelible in my memory are the happy and unforgettable moments when I was accepted as a candidate member of the CPSU and later as a party member.

I recall the day when I was designated squad commander of the training group and the first timid commands before the formation. Later came the confidence, reasonableness and thinking, characteristic of a commander. But it is one thing to command one's own comrades and another matter to command soldiers in the troops, to train and educate them and be responsible for them. We, the fourth-year students, have yet to experience that in the practical training with the troops. There we will also have to show our engineering knowledge.

This will be our first test of officer maturity. Our senior comrades and instructors tell us about the difficult, but honorable profession of a railroad troops' officer. Each of them has covered the difficult path of a commander himself. There is Colonel (Ret) docent A. Savko, instructor of the artificial structure construction department. He is a veteran of the Great Patriotic War. More than one railroad bridge was erected under his leadership. For many years now, Savko has been passing on to us, the youth, his knowledge and ability to think logically, as an engineer, and to lead a subunit (podrazdeleniye) efficiently in construction work.

Before coming to the school, Colonel N. Yegorov served in Siberia. He commanded a bridge battalion and a mechanization subunit. Now Yegorov is teaching us how to organize work in restoring and obstruction of railroads during wartime.

Our school has an excellent training material base, modern equipment and training grounds where the students improve their practical knowledge. Many of my friends participate in the work of the students' military research group and are engaged in invention and innovation.

The school is situated in the center of Leningrad. We often go to museums, theaters and concert halls and visit places of revolutionary, labor and combat glory of the hero-city.

My advice to youths who would want to enter our school is: above all, they must have a strong desire to become officers of the tank troops and agencies of military communications. Secondly, do not sit by and wait for something, but prepare themselves for an officer career starting with their schooldays. It is very important to strengthen oneself physically. I advise them to pay special attention to the exact sciences. Then, I am confident, the dreams will come true.

12567

CSO: 1801/270

DOSAAF

RESULTS OF DOSAAF CENTRAL COMMITTEE PLENUM SUMMARIZED

Moscow SOVETSKIY PATRIOT in Russian 18 Mar 84 p 1

[Editorial: "Increase the Effectiveness of Mass-Defense Work"]

[Text] The 3rd USSR DOSAAF Central Committee Plenum discussed the results of the February CPSU Central Committee Plenum and the tasks of the DOSAAF organizations stemming from the speech of CPSU Central Committee General Secretary comrade K. U. Chernenko at the Plenum.

Having analyzed the results achieved during 1983, the plenum noted that tasks which faced the Defense Society on the whole had been carried out.

Defense organizations had done much in improving education of DOSAAF members in the spirit of Soviet patriotism and socialist internationalism, selfless devotion to the Communist Party and constant readiness to defend the socialist Motherland.

The majority of DOSAAF committees are skillfully combining military and patriotic indoctrination of young people with practical instruction of their fundamentals of military affairs. The plan of training specialists for the Army and Navy has been successfully implemented. Graduates of DOSAAF schools and flying clubs, in most cases, receive the necessary knowledge and skills for service in the Armed Forces of the USSR.

The 1983 plan for training personnel of mass technical professions for the economy was fulfilled by 101.9 percent and 2,101,000 specialists were trained.

Defense Society committees, jointly with trade unions, the Komsomol and sports organizations, continued work on implementing the resolution of the CPSU Central Committee and the USSR Council of Ministers "On the Further Rise in the Mass Nature of Physical Culture and Sports" and involving workers and especially young people in regular sports activities. There is a continuous process ongoing for strengthening and further improving the material and technical base and developing the financial and economic activities.

Furthermore, it was noted at the plenum that the DOSAAF organizations still have many unsettled questions and unrealized possibilities. Indicative of the formal approach of a number of DOSAAF committees to ideological work is the

fact that the number of resolutions adopted by them for military and patriotic indoctrination increased, but the situation essentially has not improved.

By far not all of the collectives are achieving a unity of patriotic and international indoctrination of DOSAAF members and teaching them the fundamentals of military affairs. In many of the rayon and city DOSAAF organizations of Tajikistan only from 4 to 7 percent of the DOSAAF members are involved in technical circles. In the Ivanovo, Kaluga and certain other oblasts there are DOSAAF committees which make poor use in military and patriotic indoctrination of the Society's newspapers and magazines, book and descriptive products of the USSR DOSAAF Publishing House and films produced at the order of the USSR DOSAAF Central Committee.

Shortcomings in training specialists for the Army and Navy were also exposed at the plenum. Individual committees and administrators of DOSAAF educational organizations are not showing the proper persistence in fulfilling the planned goals and improving the quality of training specialists for the USSR Armed Forces.

As before, the level of development of technical and military related sports does not fully correspond to today's requirements, the Defense Society's capabilities and the needs of young people. There are serious shortcomings in this work in the DOSAAF organizations of the Kazakh and Turkmen SSR's, the Moscow, Orenburg and Tambov Oblasts and the Yakutsk and Dagestan ASSR's.

Individual committees have not mastered the modern methods of leadership. A common shortcoming of many of them is poor monitoring of implementation of their own decisions and also directives and recommendations of higher bodies. Due to the lack of proper monitoring, in a number of committees there continue to take place such negative phenomena as waste and abuse, losses and misappropriation of physical and monetary assets. Specifically, serious shortcomings were disclosed in the DOSAAF committees and organizations of the Murmansk and Orenburg Oblasts.

Certain flaws in the selection, placement and education of personnel also account for the neglect. Still, the party's requirement for combining experienced and young personnel and for the more active advancement of women to work in the management bodies of DOSAAF is slowly being implemented.

Many committees and their administrators are still not concerned enough with increasing the level of managing the work of primary organizations and turning them into centers of mass defense work and are not giving them the proper assistance, especially the rural and remote organizations.

Based on the requirements of the party, the USSR DOSAAF Central Committee Plenum specified measures for further improving the management of activities of the Defense Society organizations, strengthening organization, order and discipline and fostering in every worker and every activist a high sense of responsibility for carrying out the tasks facing the Defense Society.

Under the direction of party and soviet organs and in close cooperation with trade unions, the Komsomol, organizations of the All-Union Society "Znaniye", political organs of the Army and Navy and military commissariats, the DOSAAF committees should organize an explanation and thorough study of the materials of the February (1984) CPSU Central Committee Plenum and the speeches of the General Secretary of the CPSU Central Committee comrade K. U. Chernenko at the plenum and at the meeting of the voters of the Kuybyshev election district of Moscow.

For these purposes, it is recommended that lectures and reports, thematic evenings, meetings and interviews be conducted on press materials. It is the responsibility of the administrators of DOSAAF committees and organizations to contribute personally to this work. Based on the directives of the February CPSU Central Committee Plenum that to build a new world means to be tirelessly concerned with forming the man of the new world and with his ideological and moral growth. DOSAAF organizations must continually intensify their efforts in the military and patriotic indoctrination of workers and young people. They must clearly and convincingly explain the Leninist legacy and point to the leading role of the party in building a communist society and to its tireless concern for the good of the people and for strengthening the country's defensive capability.

It further follows to denounce emphatically the policy of American imperialism and the aggressive nature of the NATO bloc and to wage a relentless struggle against bourgeois ideology.

It is necessary everyday to improve the style and methods of the committees' administrative activities and to raise the level of their organizational work and the effectiveness of work verification. In managing all aspects of the Society's activities and all of its links, it is necessary to show efficiency, specificity and purposefulness, achieving high practical results.

In the future, as it is written in the plenum's resolution, it is important to implement strictly the personnel policy drawn up by the 26th Party Congress and subsequent CPSU Central Committee Plenums and on this basis continually improve the qualitative composition of administrators of committees, educational organizations and production enterprises and of all Defense Society staff members. In so doing, be guided by the direction of comrade K. U. Chernenko that the Leninist style in all its diversity and richness must become a necessity of the soul and an indispensable tool of every administrator.

It is suggested that the committees of the Society put into practice the party's requirements on increasing the role of socialist competition in achieving high results and in educating workers.

The resolution of the plenum pointed out that the successful fulfillment of the tasks placed before the Defense Society by the Communist Party and the Soviet government is directly dependent on the further improvement of aggressiveness, quality and effectiveness of work of primary DOSAAF organizations which in practice must become the centers of mass defense work.

Armed with the statements of CPSU Central Committee General Secretary comrade K. U. Chernenko that henceforth the party will show concern for strengthening our country's defensive capability, DOSAAF committees and educational organizations are called upon to improve the quality of training young people for service in the Army and Navy in every possible way. The plenum further made it incumbent upon the administrators of DOSAAF educational organizations to implement instruction of students in strict compliance with the requirements of governing documents, to use modern methods of instruction and education and to raise the quality and effectiveness of political-education work unremittingly.

It is also important that the DOSAAF central committees of the union republics, the kraykom's and obkom's of DOSAAF and the sports federations further increase the role of technical and military related sports in forming harmoniously developed people, ready for labor and the defense of the country.

It is necessary to ensure a rise in the mass nature and mastery of sportsmen. Work on the introduction of such widely accessible types of sports as rifle shooting, military related all around combined tournaments, carting, motor vehicle, radio, maritime and motorcycle tournaments, modelling and other types of sports are taking on special significance in DOSAAF educational and primary organizations, especially in general-education schools, vocational and technical schools, technikums and VUZes, at enterprises, kolkhozes and sovkhoses and in the domiciles of young people.

Success in carrying out the tasks facing the Defense Society depends largely on how purposefully the expansion of the material and technical base is accomplished, meeting the present scope of mass defense, military-patriotic, educational and sports work and ensuring its high quality. Therefore, the DOSAAF committees should make optimum use of local capabilities and resources for building school buildings and the most simple sports installations and take decisive measures for full development of allocated capital investments.

A matter of extreme importance is the daily persistent work on further improving financial and economic activities and increasing their effectiveness and profitability. Intensifying the monitoring and auditing work and increasing the role of DOSAAF auditing commissions must play a large role in this.

Based on the requirements of the February (1984) CPSU Central Committee Plenum, the resolution of the USSR DOSAAF Central Committee Plenum specifies specific tasks of increasing the effectiveness of military-patriotic indoctrination and mass defense, educational and sports work. It is the duty of the DOSAAF central committees, the kraykoms and obkoms to organize the study of the materials of the plenum by the staff members and activists and to ensure a business-like discussion at committee plenums and seminars of the administrators of primary, educational and sports organizations. All this work should help achieve new successes in fulfilling the planned goals and socialist obligations.

12567

CSO: 1801/274

DOSAAF

## ROLE OF WOMEN IN DOSAAF ORGANIZATIONS

Moscow SOVETSKIY PATRIOT in Russian 3 Mar 84 p 3

[Article by M. Alekseyev: "Women in the Ranks of DOSAAF Justify the Confidence of the Motherland"]

[Excerpts] The country is proud of the valiant labor of Soviet women in the national economy, in the field of state and public work, and praises their maternal feat. This was emphasized with new strength in the Address of the CPSU Central Committee to All Voters and Citizens of the Union of Soviet Socialist Republics.

Today, on the eve of the famous holiday International Women's Day, it is appropriate to remember also what a great role the heroic daughters of our nation have played and are playing in strengthening the country's defensive capability, in developing mass-defensive work and in the safeguarding socialist achievements.

There are now over 40 million women in the Defense Society. Today, the paths to the sky, motor race tracks, firing points and competition in radio sports are also calling brave and active girls. Currently about 7,400,000 women are involved in technical and military-related sports. In the union republics alone, not counting the RSFSR, in the course of the 8th Summer Games of the Peoples of the USSR, 92,000 female participants went to the starting line in radio sports, 20,000 in motor sports and 3,000 in parachuting. High results were achieved by the Games' champions S. Uspenskaya and Ye. Oktyabr'skaya in high-speed underwater swimming, V. Fesenko-Konovalova in track motor racing, G. Petrochka in sport radio direction finding and I. Adabash in aircraft sports.

Women play a large role in the management of DOSAAF organizations. Mariya Geogiyevna Getalo has successfully headed the Chita DOSAAF Central Raykom for over 10 years now. She was a gunner-radio operator on a dive-bomber and has been given many government awards. Recently she was given the title of Honored Culture Worker of the RSFSR.

It was noted at the 9th All-Union DOSAAF Congress that the number of women among the permanent staff members and activists has doubled. They head more than 40,000 primary organizations and over 150,000 auditing commissions. Women are also widely represented in other levels of the Defense Society, in

particular as rayon and city committee instructors. Many of them display high activity and creative initiative.

The Defense Society faces great and important tasks in light of the decisions of the 26th Party Congress and the subsequent CPSU Central Committee Plenums. New demands are being placed upon them by the decisions of the special February (1984) Central Committee Plenum. The million-strong detachment of women-members of the Order of Lenin and the Order of the Red Banner All-Union DOSAAF will make a worthy contribution in carrying out these tasks.

12567

CSO: 1801/270

DOSAAF

IMPROVED MILITARY-PATRIOTIC EDUCATION OF KAZAKH YOUTH STRESSED

Moscow KRYL'YA RODINY in Russian No 11, Nov 83 (signed to press 13 Oct 83 )  
pp 6-7

/Article by S. Abdrakhmanov, First secretary Kazakh Komsomol Central Committee:  
"We Must Continue"/

/Text/ On the eve of the 66th anniversary of the October Revolution and the 65th anniversary of the Komsomol, the Central Committee of the Kazakh SSR Komsomol organized an agitation cruise on Lake Balkhash. The participants in the cruise--propagandists, lecturers, art workers, writers, party and labor veterans and veterans of the Great Patriotic War--visited enterprises and construction projects in the Balkhash area, sovkhoses, kolkhoses and fishermen. Meeting with workers, field laborers and youth, they spoke of the republic achievements and achievements of the entire country in building developed socialism. They also discussed how the plans of the 11th Five-Year Plan and the historical resolutions of the November (1982) and June (1983) Central Committee Party Plenums are being realized and put into practice.

Talgat Yakubovich Begel'dinov, former ground attack pilot and twice Hero of the Soviet Union, reminisced about his friends in combat, similar in age to today's Komsomol members, about how in the war's fiery skies they annihilated the German fascist invaders and accomplished great feats for freedom and independence of the Motherland. They listened to the famous aerial warrior with great interest and attention.

During these meetings, the young people spoke of their own labor achievements--and they were impressive! Kazakhstan is an area of powerful industry and agriculture. Every year in the republic, dozens of new, large enterprises are modernized and put into operation and boundless virgin lands are transformed. Over 300 projects in the current 5-year period have been called vital Komsomol-youth construction projects, and 2,311 youth collectives bear the honorary title of collectives of communist labor. They earned this title through exemplary labor, strict discipline and good organization. Many young workers and kolkhoz farmers have been awarded high state awards and the names of the winners of socialist competition are entered on the rayon, oblast and republic Boards of Honor.

During the cruise, a Komsomol Central Committee team of agitators conducted a number of mass-defense and military-patriotic activities. Lectures were read on military-patriotic topics, thematic evenings were held, meetings were organized with military-age youths who were getting ready for service in the Armed Forces and films were shown about the Great Patriotic War and the training days of today's Army, Air Force and Navy.

At the June (1983) CPSU Central Committee Plenum, a new strong emphasis was placed on one of the main and crucial tasks of the Komsomol, which is to help the party in further improving the military-patriotic education of young people. We are striving to fulfill the party's goal as thoroughly and perfectly as possible.

We devote daily attention to military-patriotic education, regarding it as an integral part of the ideological training of youth. Jointly with Defense Society organizations, we organize and conduct Lenin readings, parties for pre-military age youth, meetings with party and labor veterans and with soldiers from local garrisons, under the supervision of party agencies. The network of defense-sport centers, various technical clubs, circles and sections is growing continually. The military-sporting games "Zarnitsa" and "Orlenok," which involve many thousands of young republic boys and girls, are being improved.

Presently in Kazakhstan there are over 2,000 various youth military-patriotic schools and associations operating, such as "Yunyy Letchik" /Young Airman/, "Yunyy Kosmonavt" /Young Cosmonaut/, "Yunyy Moryak" /Young Sailor/, "Yunyy Radist" /Young Radio Operator/ and others. In cities, in large enterprises, and at sovkhoses and kolkhozes, there are 307 universities of military studies and military-patriotic education, most of them set up on the initiative of Komsomol and defense organizations. The work in the universities and youth associations is being done by experienced instructors, reserve officers and participants in the past war.

Interesting experience has been accumulated in the Aktyubinsk Young Airmen's School imeni V. I. Patsayev. Propaganda about the combat traditions of Soviet aviation is presented well at the school. Participants in past battles, veterans of the USSR Air Force and civil aviation pilots speak before the young fliers. The children do a lot of corresponding with museums and veterans' councils. Lectures are read in the school about the heroic actions of Soviet fliers in the battle of Moscow, in the skies over Stalingrad, at the Orel-Kursk Bulge and over the Dnieper and Kiev. The students of the young airmen school master a basic knowledge of military affairs, are introduced to aviation professions and are trained by experienced instructors in firing weapons. A good shooting range and sports village have been built at the school.

We have similar schools in other cities as well. In Semipalatinsk, for example, the so-called "Little Air Academy" has been already operating successfully for nearly 20 years. The initiators of its opening were the city Komsomol Committee, communists and Komsomol members of the local aviation enterprise of civil aviation. The city party committee approved the undertaking and helped select experienced instructors and educators. And the youth came one after another to their "Academy." Over a 2-year period here, they study radio communication,

navigation and the fundamentals of aerodynamics. In the parachute classroom they master the principles of parachute training and in a special simulator obtain elementary skills in air navigation.

So, step by step in the evening hours and on their days off, the Semipalatinsk youth join in the flying profession. The young people literally "stick" to the skies for 2 years. Suffice it to say that 80 percent of the youth graduates of the "Academy" later enroll in military and civil aviation institutions and VUZ's training engineering personnel for industry. S. Sarbayev, I. Podol'skiy and G. Yevstratov became pilots and R. Ayseitov heads one of the subunits /podrazdeleniye/ of the aviation enterprise of the Kazakh Civil Air Fleet Administration. S. Krivobokov, having graduated from an institute, is successfully working as an engineer at the Tashkent Aircraft Plant imeni V. P. Chkalov.

Just as everywhere in the country, the enthusiasm of Kazakh youth for aviation became widespread during the legendary years of the first 5-year plans. The slogan of the Ninth Komsomol Congress--"Komsomol member, to the airplane"--called hundreds and thousands of young patriots into the flying clubs of the Society for Assistance to the Defense, Aviation and Chemical Construction of the USSR and into its schools for pilots, navigators, aircraft technicians and mechanics. It was from their ranks that aerial aces grew up, such as twice Heroes of the Soviet Union S. Luganskiy, L. Beda, T. Begel'dinov, I. Pavlov and Heroes of the Soviet Union N. Abdirov and P. Zheleznyakov. Thousands of young patriots are being brought up following their example.

The traditions laid by the heroes of past battles are being piously upheld and repeated. DOSAAF plays a large role here. The flying clubs and flying sport clubs of Kazakhstan are doing much work in training aircraft sport-pilots, parachutists and glider-pilots. A relatively new sport is becoming increasingly popular--hang gliding. Hundreds of model airplane circles and sections are active in middle schools and Young Pioneer Palaces.

The republic's leading aviation training organization is the Alma-Ata Flying Club. Here a whole galaxy of talented aviation sportsmen grew up--dozens of masters and candidate-masters in sports and hundreds of sportsmen with official standings. A. Ol'khovskiy, R. Nazmutdinov, V. Gusev and P. Pavlenko were master pilots of sport aircraft. They repeatedly gained the victory and placed in the prizes at republic and national contests. Others became first-class pilots and fly the high-speed jet and turbojet passenger airliners over the airways. T. Pavlenko, for example, set several world records as part of a female crew on a nonstop flight from Sofia to Vladivostok.

Komsomol member Gul'dzhan Abdulbakiyeva joined the flying club as a schoolgirl. After 2 years of persistent work under the guidance of experienced instructors, Gul'dzhan became a master of sports of the USSR. At the All-Union Aerobatics Competition in 1977 she achieved high results and rose to the highest level of the honor pedestal, having become the absolute national women's champion. Now, she gladly shares her knowledge and skill with young aviation sportsmen.

Sport-pilots V. Obrevko, V. Zakablukovskiy, G. Timonina and L. Andreyeva from Alma-Ata and G. Lyatkin, V. Chekh, I. Roshchupkin and V. Zhuravlev from Karaganda

are known well in the republic. Master of sport Vladimir Zhuravlev has mastered to perfection the technique of piloting jet aircraft. He has won prizes in All-Union contests more than once and in 1980 attained the title of absolute champion of the USSR in this sport.

The ranks of aviation sportsmen are continually replenished by upperclass students of middle schools, vocational and technical schools and tekhnikums, VUZ students and workers. Among the aviation sportsmen of the Alma-Ata Flying Club are Komsomol members and pupils Ye. Kulikova and M. Sagyntayeva, student Yu. Bodop'yanov and vocational and technical school student D. Lameko. They are all parachutists. They have taken a keen interest in this sport only quite recently, but they already have sport titles and each of them has dozens of jumps to their credit. Going out for sports helps them study better, disciplines them and develops purposeful and strong-willed qualities.

Twice a year we see military-age youths off to serve in the army. We receive word from units /chasti/ and subunits /podrazdeleniya/ about how they are serving. A number of the Komsomol-soldiers have been awarded high state awards and given incentives by the command for exemplary performance of international duty. Among them are soldier-parachutists who passed initial parachute training in the flying clubs of the Defense Society: Komsomol members A. Betts, A. Markelov, Ye. Ryazanov, K. Krivosheyev, A. Gerasimenko and others. It is noteworthy that, having returned to their native areas, all of them continue to be actively involved in their favorite sport and are teaching young parachutists.

At the same time, we understand that in this work we have much untapped potential, especially in the development of technical and military-applied types of sports, including aviation. The Komsomol organization of the Guryev, North Kazakhstan, Turgay and Dzhekazgan Oblasts are still not manifesting sufficient care in developing them. Here they sometimes complain about the shortage of qualified sports and technical personnel, coaches, instructors and judges. Of course, we are experiencing some difficulties in this area, but they are not the main thing. In the Ural Oblast, for example, they have their own flying club in which there are instructors as well as trained sportsmen. The Komsomol obkom, jointly with the city and oblast defense organizations, must in our opinion show a little more effort and persistence and the problem can be solved locally, without waiting for someone to send them instructors, coaches and judges.

Some Komsomol organizations are conducting many defense-mass and military-patriotic activities, but their effectiveness at times remains low, since they are held "for the sake of filling a square," formally, with low attendance of Komsomol members. In a number of places, the military-patriotic work is shifted completely to the shoulders of minor officials. By way of illustration, when a meeting with participants in the Great Patriotic War or veterans of the Armed Forces is organized, why couldn't the secretary of the rayon, city or oblast Komsomol committee head such a meeting? But these are not isolated facts, when responsible workers do not even consider their own presence at such activities as mandatory.

I would like to point out something else. One of the most popular forms of aircraft sport is modeling. In school circles, laboratories of Young Pioneer

Palaces and at young technician stations, the children are enthusiastically building, making or designing something. They go to the stores for missing parts and search for all kinds of kits at the counters. Frequently they come away disappointed. The stores do not have the "goods" they need. There are no high-quality parts or complete kits for airplane or ship model activities and no ordinary kits so they can assemble a radio receiver, radio set, ship, airplane or helicopter with their own hands. And not simply to assemble, but so they would "talk," "fly" and "float."

Yet, some enterprises, in their rush for consumer goods output volume, supply the shops with toys that are complicated, incomprehensible and practically useless for the children. They are expensive and their use is extremely limited. It is necessary to furnish children well with that which would help develop their inquisitiveness and, above all, give them access to technical and military-applied types of sports.

You see, as indicated by experience, sports activities, including technical sports, must begin in the youthful years so that the qualities necessary for the future defense of our great socialist Motherland are developed in every young person, no matter where he lives--in the city or in the most remote hamlet. We are solving this problem and in the future will do so with still greater perseverance and purposefulness, in the spirit of the present-day requirements of the party.

COPYRIGHT: "Kryl'ya Rodiny," 1983

12567

CSO: 1801/194

END