

338165

JPRS-CST-86-041

1 OCTOBER 1986

# China Report

SCIENCE AND TECHNOLOGY

HUMAN, ANIMAL EXPERIMENTS DETERMINE  
LASER INJURY THRESHOLDS

BTIC QUALITY IMPROVED

DEPARTMENT OF COMMERCE  
Approved for public release;  
rights are unlimited

19981019 059



FOREIGN BROADCAST INFORMATION SERVICE

REPRODUCED BY  
U.S. DEPARTMENT OF COMMERCE  
NATIONAL TECHNICAL  
INFORMATION SERVICE  
SPRINGFIELD, VA. 22161

1  
133  
A47

#### NOTE

JPRS publications contain information primarily from foreign newspapers, periodicals and books, but also from news agency transmissions and broadcasts. Materials from foreign-language sources are translated; those from English-language sources are transcribed or reprinted, with the original phrasing and other characteristics retained.

Headlines, editorial reports, and material enclosed in brackets [ ] are supplied by JPRS. Processing indicators such as [Text] or [Excerpt] in the first line of each item, or following the last line of a brief, indicate how the original information was processed. Where no processing indicator is given, the information was summarized or extracted.

Unfamiliar names rendered phonetically or transliterated are enclosed in parentheses. Words or names preceded by a question mark and enclosed in parentheses were not clear in the original but have been supplied as appropriate in context. Other unattributed parenthetical notes within the body of an item originate with the source. Times within items are as given by source.

The contents of this publication in no way represent the policies, views or attitudes of the U.S. Government.

#### PROCUREMENT OF PUBLICATIONS

JPRS publications may be ordered from the National Technical Information Service, Springfield, Virginia 22161. In ordering, it is recommended that the JPRS number, title, date and author, if applicable, of publication be cited.

Current JPRS publications are announced in Government Reports Announcements issued semi-monthly by the National Technical Information Service, and are listed in the Monthly Catalog of U.S. Government Publications issued by the Superintendent of Documents, U.S. Government Printing Office, Washington, D.C. 20402.

Correspondence pertaining to matters other than procurement may be addressed to Joint Publications Research Service, 1000 North Glebe Road, Arlington, Virginia 22201.

CHINA REPORT  
SCIENCE AND TECHNOLOGY  
HUMAN, ANIMAL EXPERIMENTS DETERMINE  
LASER INJURY THRESHOLDS

- Shanghai ZHONGGUO JIGUANG in Chinese Vol 12 No 10, 20 Oct 85 pp 577-640  
Shanghai ZHONGGUO JIGUANG in Chinese Vol 12 No 12, 20 Dec 85 pp 735-738  
Shanghai YINGYONG JIGUANG in Chinese Vol 6 No 3, Jun 86 pp 141-144

CONTENTS

ZHONGGUO JIGUANG No 10, 20 Oct 85

Editor's Note.....	1
Measurement of Erythematous Reaction by Argon Laser Light for Skin of Yellow Race (pp 577-581) (Li Jishi, et al.).....	2
Study of Injury Threshold of CW Nd:YAG Laser Light for Human Skin (pp 582-585) (Ma Baozhang, et al.).....	11
Injury Threshold of Ruby Laser Irradiation on Human Skin (pp 586-588) (Chen Ji, et al.).....	17
Acute Injury Threshold Level of CO <sub>2</sub> Laser Light for Skin of Yellow Race (pp 589-591, 588) (Shi Hongmin, et al.).....	22
Study of Injury Threshold of Skin Irradiated With 265 nm Pulsed Laser Light (pp 592-596) (Li Zhaozhang, et al.).....	28
Investigation of Laser Injury Threshold of Skin (pp 597-599, 596) (Wu Qingzhen, et al.).....	35

Injury Threshold of Retina Irradiated by Argon Laser Light (pp 600-602) (Wang Kangsun, et al.).....	42
Experimental Study on Injury Threshold of Animal Retinas by 488 nm Laser Irradiation (pp 603-605) (Zhao Tongzhen, et al.).....	47
Research on Injury Threshold of Rabbit Cornea by CO <sub>2</sub> Laser (pp 606-608, 605) (Wang Kangsun, et al.).....	53
Research on Injury Threshold of Gray Rabbit's Retina by Q-Switched, Frequency Doubled Nd <sup>3+</sup> :YAG Laser (pp 609-611) (Wang Kangsun, et al.).....	58
Retinal Injury Threshold by CW Nd <sup>3+</sup> :YAG Laser Light (pp 612-614) (Xu Jiemin, et al.).....	63
Injury Threshold of Human Eye by Pulsed YAG Laser Beams, Pathological Observation (pp 615-617) (Chen Rongjia, et al.).....	68
Study of Retinal Injury Threshold for Nd:YAG Frequency-Doubled Laser Light (pp 618-620) (Xu Jiemin, et al.).....	72
Retinal Injury Threshold of Long Pulse Ruby Laser Light (pp 621-622) (Xu Jiemin, et al.).....	77
A Study of Single Mode He-Ne Laser Injury Threshold of Rabbit Eye (pp 623-625, 585) (Ding Weiling, et al.).....	81
Research on Injury Threshold of Chinese Yellow Skin by CW Nd:YAG Laser Beam Irradiation (pp 626-628) (Wu Tingbi, et al.).....	87
Research on Injury Threshold of Chinese Yellow Skin Irradiated With 300 μs Pulsed Neodymium Glass Laser Light (pp 628-630) (Wu Tingbi, et al.).....	92
Injury Threshold of Ruby Laser Irradiation on Pig Skin (pp 631-632) (Wang Jun, et al.).....	96
Morphological Analysis of Retinal Injury in Rabbits Arising From Argon Laser Irradiation (pp 633-634) (Zhang Xiaoru, et al.).....	101
Retinal Injury Threshold of Rabbits, Monkeys Irradiated by CW or Pulsed YAG Laser Beams (pp 634-635) (Chu Renyuan, et al.).....	104

Experimental Study on Retinal Injury Threshold of Animal by  
694.3 nm Laser Irradiation (pp 636-637)  
(Zhao Tongzhen, et al.)..... 108

Measurement of Laser Spot Diameter on Retina, Cornea (pp 637-638)  
(Dang Zhiping, et al.)..... 112

Measurement of Transmissivity of Argon Laser Light Through  
Rabbit's Eyes (pp 638-639)  
(Li Yujun, et al.)..... 114

ZHONGGUO JIGUANG No 12, 20 Dec 85

Injury Threshold of Skin Irradiated With 308 nm Excimer Laser  
Light Studied (pp 735-738)  
(Li Zhaozhang, et al.)..... 117

YINGYONG JIGUANG No 3, Jun 86

Laser Safety, Protection Standards Reviewed (pp 141-144)  
(Li Zhaozhang)..... 123

Editor's Note:

[Text] In the development of laser technology and application, laser safety and protection are becoming increasingly important. The State Science and Technology Commission of the People's Republic of China has given laser safety a high priority and ordered a study of "Laser Safety and Protection Standards--Measurement of the Laser Damage Threshold on Eyes and Skin." After 3 years of intensive research, the research units have accomplished their goals and a symposium was held in Guangzhou in March 1985 to summarize and exchange the results. This issue of ZHONGGUO JIGUANG is devoted to the reports of research results on the laser safety.

Limited by space, 23 papers are published in this issue and other articles will be published subsequently. Most of the papers report experimental results. Since a number of the experimental studies used basically the same method, the editors have abridged and revised some of the papers to avoid repetition and appreciate the understanding of the authors.

MEASUREMENT OF ERYTHEMATOUS REACTION BY ARGON LASER LIGHT FOR SKIN OF YELLOW RACE

Shanghai ZHONGGUO JIGUANG [CHINESE JOURNAL OF LASERS] in Chinese Vol 12, No 10, 20 Oct 85 pp 577-581

[Article by Li Jishi [2621 3444 2514], Shi Hongyu [0670 1347 3022], Tan Yankang [6223 1693 1660], Luo Panxiang [5012 3140 4382], and Chen Zhongben [7115 0112 2609] of the Department of Physics, Zhongshan Medical College, and Yuan Yuehuan [5913 1878 2970] of Zhongshan Medical College, Guangzhou]

[Text] Abstract: This paper describes an Ar<sup>+</sup> laser used for measuring the MRD<sub>50</sub> value of the skin of the yellow race. The skin erythematous reaction threshold levels for two groups of volunteers are found to be at 488.0 nm and 514.5 nm. The skin of the volunteers is exposed to laser radiation at these two wavelengths and histological examination finds the capillaries expanded and filled with erythrocytes and light edema, but there is no significant change of the cuticle.

In addition to hazards to the human eye and the central nervous system, lasers can also cause various levels of skin damage.<sup>1</sup> As the radiation level increases, the skin may show erythema, erythema with white specks, whitening of the skin, blisters, burns, and vaporization.<sup>2</sup> The erythema is caused by capillary congestion and tissue reddening.<sup>3</sup> In research on laser safety, visual observation of the erythema is often used.<sup>4</sup> For a fixed exposure time, the minimum radiation level that causes 50 percent of erythema retention probability--the erythematous reaction threshold--is known as the MRD<sub>50</sub> value.<sup>5</sup>

The MRD<sub>50</sub> value depends on the wavelength, the radiation level, and the skin pigment. Measurement of the MRD<sub>50</sub> of the skin of the white and black races using an Ar<sup>+</sup> laser with a wavelength in the 488-514 nm range has been reported.<sup>5</sup> In this work we measure the MRD<sub>50</sub> of the skin of the yellow race using 488.0 nm and 514.5 nm Ar<sup>+</sup> lasers with a spot diameter of 0.5 cm for a duration of 1 second. The study is aimed at providing a data base for the establishment of a laser safety standard in China.

## I. Experimental Setup and Conditions

Figure 1 shows the experimental setup. The CW Ar<sup>+</sup> laser operated in the fundamental transverse mode and produces a single spectral line. The output power is continuously tunable and the maximum output is 2.5 W.

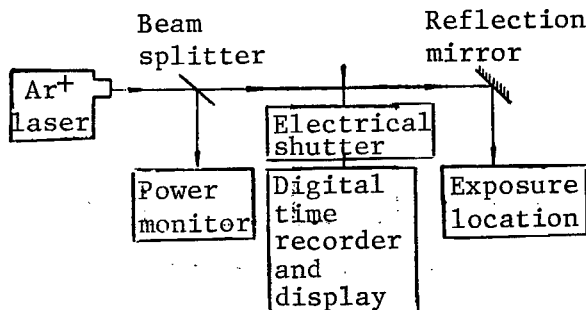

Figure 1. Experimental setup

The beam from the Ar<sup>+</sup> laser passes through a beam splitter, an electrically controlled shutter, and is reflected by a mirror. The beam then illuminates the skin at normal incidence. The Gaussian distribution amplitude of the laser power is measured by moving an orifice (less than 1/10 of the beam diameter) across the beam at the illumination location. The light spot diameter<sup>2-4</sup> is the distance between the two 1/e<sup>2</sup> points. In our experiment the spot diameter is 0.5 cm.

A power monitor device is used in the experiment. The monitor consists of a silicon photocell (or a silicon photodiode) and a sensitive galvanometer. The stability of the photoelectric current is a measure of the light power stability. All experiments are made with the light power stabilized to within 5 percent.

For a fixed light power and spot size, the radiation of the skin depends on the illumination time. The time is controlled by an electrical shutter in the optical path. The irradiation time is 1 second with an error less than 5 percent. All measurements are made at room temperature ( $20 \pm 5^\circ\text{C}$ ) and under a relative humidity less than 80 percent.

Each group of volunteers consists of half males and half females in the 20-22-year-old age range. The volunteers are all of the yellow race but with varying skin complexion. There is no damage on the skin of the side of the right forearm before the laser irradiation. After cleaning, the target location is marked with the lattice pattern in Figure 2. The center-to-center distance of the lattice is 2 cm, the numbers 1, 2, 3, 4, and 5 indicate the locations for five different radiation levels. No anaesthesia was applied. Observation and erythema counting were made 5 minutes after each irradiation.

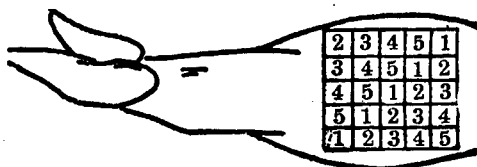

Figure 2. Arrangement of the irradiation spots on the side of the forearm

## II. Experimental Method and Data

Using the setup described above, preliminary tests are made on several volunteers using Ar<sup>+</sup> lasers (488.0 nm and 514.5 nm). The minimum radiation level for producing erythema that vanishes within 5 minutes is estimated. The maximum radiation level for retaining erythema after 5 minutes but without causing whitening is also estimated. The formal measurements are based on the estimated maximum and minimum radiation level. The energy densities at 488.0 nm for the five spots numbered 1 through 5 are respectively 6.67, 6.07, 5.52, 5.03, and 4.58 J/cm<sup>2</sup>. For the 514.5 nm Ar<sup>+</sup> laser, the energy densities are 8.85, 8.06, 7.33, 6.67, and 6.07 J/cm<sup>2</sup>. The ratio of adjacent levels is 1:0.91.

In the formal tests, the six volunteers in the same group are subjected to 1-second exposures at the five different radiation levels of the same wavelength according to the pattern in Figure 2. Each volunteer is subjected to five radiation levels at five spots and n is equal to 30 for the whole group. Five minutes after the exposure, the erythema is examined by two observers under the same lighting conditions to determine the erythema retention number r and the probability r/n. The data are listed in Tables 1 and 2.

Table 1. Erythema Retention Number at 5 Minutes After a 1-Second Exposure of a 488.0 nm Ar<sup>+</sup> Laser

<u>Number</u>	<u>Radiation level (J/cm<sup>2</sup>)</u>	<u>Number of shots n</u>	<u>Erythema retention r</u>	<u>Probability P</u>
1	6.67	30	28	0.93
2	6.07	30	21	0.70
3	5.52	30	14	0.47
4	5.03	30	6	0.21
5	4.58	30	0	0

Table 2. Erythema Retention Number at 5 Minutes After a 1-Second Exposure of a 514.5 nm Ar<sup>+</sup> Laser

Number	Radiation level (J/cm <sup>2</sup> )	Number of shots n	Erythema retention r	Probability P
1	8.85	30	29	0.97
2	8.06	30	25	0.83
3	7.33	30	21	0.70
4	6.67	30	12	0.40
5	6.07	30	0	0

### III. Data Processing and Results

Using the data in Tables 1 and 2, the linear regression equation of the unit retention probability y [out of 10] versus the logarithmic radiation level x, the MRD<sub>50</sub> value and the confidence level are found by a statistical regression method.<sup>6,7</sup>

(1) MRD<sub>50</sub> of 488.0 nm Ar<sup>+</sup> radiation

The linear regression equation for the 488.0 nm Ar<sup>+</sup> laser on the skin of the yellow race is found to be

$$y = 20.430x - 10.342$$

Figure 3 shows the regression straight line. As can be seen, four experimental points fall on the straight line and the first experimental point deviates slightly from the straight line.

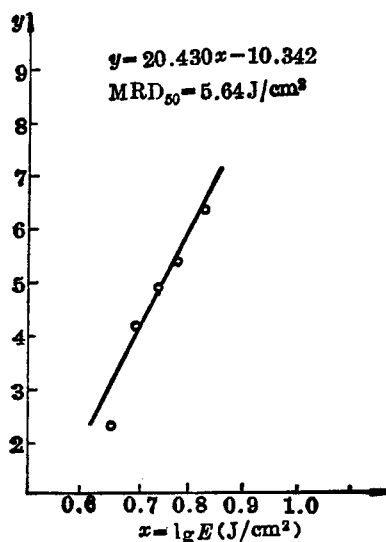

Figure 3. Regression straight line of the erythematous reaction due to 488.0 nm Ar<sup>+</sup> laser. The open circles are the experimental points.

Using the regression equation of Figure 3, the logarithmic radiation level  $x = m$  corresponding to  $y = 5$  (i.e., 50 percent probability for erythema retention) can be found and  $MRD_{50} = 1g^{-1} m$ . Calculations show that

$$MRD_{50} = 5.64 \text{ J/cm}^2$$

and the 95 percent confidence range for  $MRD_{50}$  is

$$5.47 \text{ J/cm}^2 \sim 5.81 \text{ J/cm}^2.$$

(2)  $MRD_{50}$  of 514.5 nm  $Ar^+$  radiation

Calculations show that the linear regression equation for the 514.5 nm  $Ar^+$  laser is

$$y = 19.990 x - 11.958$$

Figure 4 shows the regression straight line. Again, all except one point fall on the straight line. The calculated  $MRD_{50}$  is

$$MRD_{50} = 7.05 \text{ J/cm}^2$$

and the 95 percent confidence range for  $MRD_{50}$  is

$$6.76 \text{ J/cm}^2 \sim 7.28 \text{ J/cm}^2$$

The  $MRD_{50}$  results for the  $Ar^+$  laser at the two wavelengths of 488.0 nm and 514.5 nm on the skin of the yellow race are summarized in Table 3.

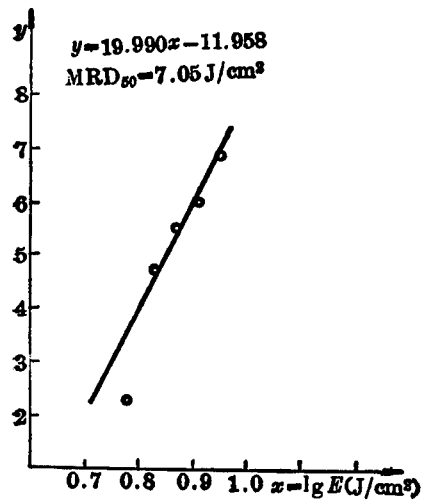

Figure 4. Regression straight line of the erythematous reaction due to 514.5 nm  $Ar^+$  laser. The open circles are the experimental points.

Table 3. MRD<sub>50</sub> of 488.0 nm and 514.5 nm Ar<sup>+</sup> Laser on the Skin of the Yellow Race

Ar <sup>+</sup> laser wavelength (nm)	MRD <sub>50</sub> (J/cm <sup>2</sup> )	MRD <sub>50</sub> 95 percent confidence range (J/cm <sup>2</sup> )
488.0	5.64	5.47 ~ 5.81
514.5	7.05	6.76 ~ 7.28

#### IV. Histological Examination

The normal skin on the side of the forearms of four volunteers of the yellow race in the 21-28 age range is irradiated with the MRD<sub>50</sub> level of 5.6 J/cm<sup>2</sup> at 488.0 nm and with the MRD<sub>50</sub> level of 7.1 J/cm<sup>2</sup> at 514.5 nm for 1 second. Histological and pathological examinations are then performed with an optical microscope for skin samples taken at the erythematous locations at 5 minutes and 30 minutes after the irradiation. On the samples taken 5 minutes after the irradiation, capillary expansion is found in the papillary layer and the shallow layer of the dermis. Most of the capillaries are filled with erythrocytes, the shallow layer of the dermis shows slight edema, the blood vessels in the deep layer of the dermis are also found to be expanded and congested, but the cuticle shows no obvious changes, as shown in Figures 5(a), 5(b), and 6(a). On the samples taken 30 minutes after the irradiation, capillary expansion is found, the congestion is slight, and no edema is observed, as shown in Figures 5(c), 5(d), and 6(b).

The histological examination results show that the effects of the MRD<sub>50</sub> radiation on the skin are the congestion of the capillaries and slight edema of the shallow layer of the dermis. No serious histological damage is found. As the erythema recedes, so do the histological and pathological changes. The erythematous reaction is therefore a reversible reaction.

#### V. Discussion

Table 3 shows that the MRD<sub>50</sub> of the 514.5 nm Ar<sup>+</sup> laser radiation is greater than that of the 488.0 nm radiation. For skin of the same color, the reflectivity of the skin for the Ar<sup>+</sup> laser light increases as the wavelength increases.<sup>3-5</sup> For the same radiation level, the absorption of the longer wavelength laser light is actually less. The radiation level leading to erythema is therefore greater for the longer wavelength.

In the multispectral output of a low power Ar<sup>+</sup> laser, the power of the 488.0 nm spectral line dominates. As the output power increases, the power of the 514.5 nm line becomes dominant. The MRD<sub>50</sub> of a multispectral Ar<sup>+</sup> laser for the skin of the yellow race is therefore probably in the 5.6 to 7.1 range and further experimental confirmation is required.

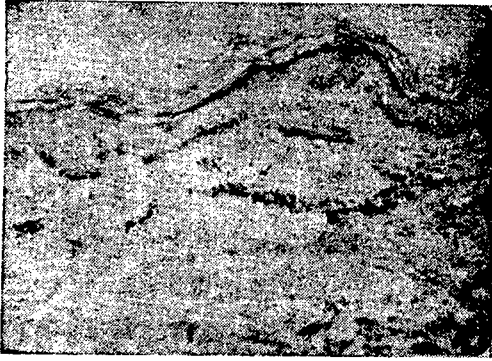

(a) After 5 minutes, capillary expansion in the papillary layer and shallow layer of the dermis, slight edema of the shallow layer of the dermis

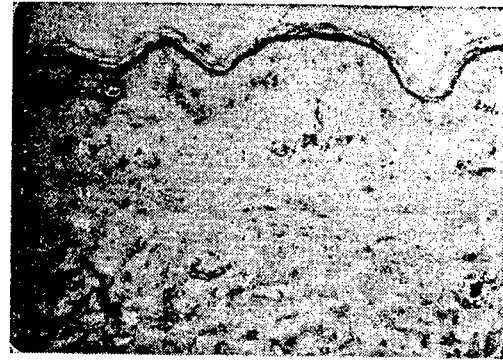

(b) After 5 minutes, capillary expansion in the deep layer of the dermis



(c) After 30 minutes, capillary still expanded, congestion decreases, edema vanishes

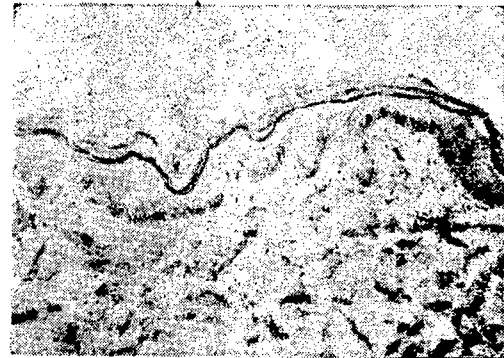

(d) After 30 minutes, capillary still expanded, congestion decreases

Figure 5. Histological and pathological changes of the skin illuminated by 488.0 nm Ar<sup>+</sup> laser at 5.6 J/cm<sup>2</sup> for 1 second (magnified 120 times)



(a) Five minutes after irradiation, blood vessels in the papillary layer of the dermis are expanded and congested

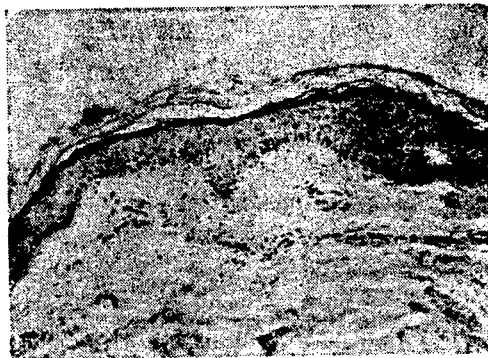

(b) Thirty minutes after the irradiation, congestion of the capillaries decreases

Figure 6. Histological and pathological changes of the skin irradiated at a 514.5 nm Ar<sup>+</sup> laser at 7.1 J/cm<sup>2</sup> for 1 second (magnified 120 times)

In 1974 Rockwell and Goldman<sup>5</sup> in the United States measured the Ar<sup>+</sup> laser MRD<sub>50</sub> for the skin of the white race to be 4.0-8.2 J/cm<sup>2</sup>. For the skin of the blacks the MRD<sub>50</sub> range is 4.5-6.0 J/cm<sup>2</sup>. The MRD<sub>50</sub> in this work falls between the results for the white race and the black race. The reflectivity of the Ar<sup>+</sup> laser light by the white skin is greater than that by the black skin.<sup>3</sup> Generally speaking, the number of black pigments of the yellow skin is greater than that of the white skin but smaller than that of the black skin. The reflectivity of the yellow skin should therefore be less than that of the white skin and greater than that of the black skin. For the same erythematous reaction, the yellow skin requires a radiation level lower than that of the white skin but higher than that of the black skin. In this sense the results of this experiment are reasonable.

In the observation results of this experiment, zero percent erythema retention probability has been observed. This will lead to some error in the calculation and will not affect the results to any appreciable level.

#### REFERENCES

1. Liu Puhe [0491 2528 0735], "Guide to Laser Safety," Scientific Publishing Co., 1982.
2. A.N. Takata, "Development of Criteria for Skin Burns," AEROSP. MED., June 1974.
3. A. Mallow, L. Chabot, "Laser Safety Handbook," 1978.
4. D. Sliney, M. Wolbarsht, "Safety With Laser and Other Optical Sources," 1980, New York.

5. R.J. Rockwell, et al., "Research on Human Skin Laser Damage Threshold, Final Report," June 1974.
6. Zhou Haijun [0719 3189 6874], et al., "Statistical Method in Biological Evaluation," People's Hygiene Publishing Co., 1983.
7. Sun Ruiyuan [1327 3843 0337], "Quantitative Pharmacology," 1963.

9698/6091

CSO: 8111/1099

## STUDY OF INJURY THRESHOLD OF CW Nd:YAG LASER LIGHT FOR HUMAN SKIN

Shanghai ZHONGGUO JIGUANG [CHINESE JOURNAL OF LASERS] in Chinese Vol 12,  
No 10, 20 Oct 85 pp 582-585

[Article by Ma Baozhang [7456 1405 4545] and Xia Weiya [1115 0251 0068] of the Ninth People's Hospital, Shanghai No 2 Medical University and Zhuo Ruipeng [0587 3843 7720], Jiang Lanying [3068 5695 5391], Hu Qingshen [5170 1987 3088], Li Zhaozhang [2621 0340 3864], and Wu Jianu [0702 1367 1166] of the Laser Laboratory, Shanghai No 2 Medical University]

[Text] Abstract: Based on the experimental results on animals and human subjects, the injury threshold MRD<sub>50</sub> of CW Nd:YAG laser for Chinese is 65.519 J/cm<sup>2</sup> for light complexion skin, 60.989 J/cm<sup>2</sup> for yellow skin, and 52.321 J/cm<sup>2</sup> for dark complexion skin. The experiments also show a close correlation between the absorption of the Nd:YAG laser light and the pigment content of the skin.

China has been engaged in laser development for 20 years but still has not established systematic laser protection measures, partly due to the lack of damage threshold data on the Chinese people. In this work we study the skin damage threshold of CW Nd:YAG laser in order to provide some data for establishing China's laser protection standard.

This experiment consists of two parts: animal tests and tests on human skin. The Nd:YAG laser used (shown in Figure 1) was developed jointly by the Shanghai Navigation Equipment Plant and the Shanghai No 2 Medical University.

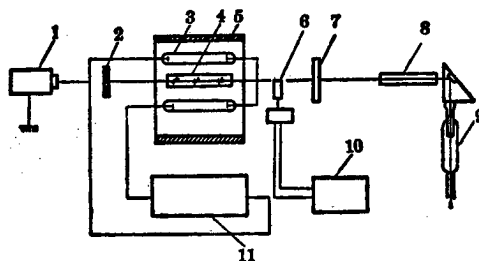

Figure 1. Schematic diagram of the Nd<sup>3+</sup>:YAG laser

1--Energy monitor; 2--Total reflection film; 3--Krypton lamp; 4--YAG rod;  
5--Focusing cavity (dual lamp); 6--Optical path control relay; 7--Transmission film; 8--Light guide system; 9--Power density control; 10--Timing control;  
11--Power system

## I. Animal Tests

### 1. Method

Three white-haired pigs weighing 6-7 kilograms were selected as test subjects, 2 cc/kg of 2.5 percent sodium isobarbiturate was injected into the subject's abdominal cavity. The test animals were anaesthetized and shaven, and 2 cm<sup>2</sup> grids were painted on the two sides of the abdomen. The tests were conducted at 15.5°C and 61 percent humidity.

Table 1. Experimental Parameters of the Laser Tests

<u>Output wavelength</u> ( $\mu\text{m}$ )	<u>Output power</u> (W)	<u>Divergence angle</u> (mrad)	<u>Spot size</u> (mm)	<u>Mode of illumination</u>	<u>Exposure time</u> (min)	<u>Error in energy</u> (%)
1.06 CW	50 stable to 5%	5	5	open shutter pulse mode	1 $\pm$ 0.7%	$\pm$ 3

Five doses were used in the preliminary test, 30 shots were made at each dosage, 10 points on each animal, and the shots were made both on the abdomen and on the back. After each shot observations were made to determine the time for the erythema to appear, the size of the erythema, and the time for the erythema to disappear. For each dosage pathological observations were made on one of the animals during the erythema and after the erythema disappeared.

### 2. Results

The criterion for erythematous reaction is for the erythema to last at least 3 minutes. The results are shown in Table 2.

Table 2. Erythematous Results

<u>Group</u>	<u>Power density</u> (W/cm <sup>2</sup> )	<u>Number of shots</u>	<u>Erythematous rate (%)</u>
1	43.82	30	3
2	49.43	30	17
3	57.58	29	38
4	65.73	29	69
5	73.89	30	93

The results were analyzed using a weighted linear regression method.

The regression equation was:

$$y = -9.644 + 13.788x$$

MRD<sub>50</sub>: 59.385 J/cm<sup>2</sup>

The 95 percent confidence level was:

$$56.950 \sim 61.923 \text{ J/cm}^2$$

The Chi square test showed  $P < 0.05$  (see Figure 2). The histological biopsy showed normal reaction in most cases and a few cases of slight blood vessel dilation (see Figure 3).

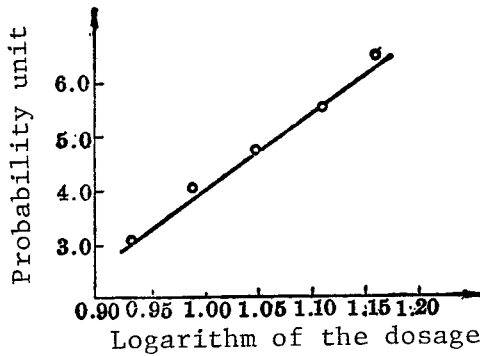

Figure 2. Regression line for animal test results



Figure 3. No obvious changes

## II. Human Skin Tests

### 1. Method

Ten volunteers were chosen, five males and five females, from the 35-53 age group. All subjects had healthy skin, three had light complexions, two had dark complexions, and five had the usual yellow skin of the Chinese. The skin temperature before testing was measured to be 24-28.5°C. After washing the skin of the two forearms, 15 squares were drawn on the skin, with a total of 30 marked locations on each subject. Six shots each were made at 3-5 dosages, 3 on the left arm and 3 on the right arm.

Observations were made after each shot to determine the appearance time, size and retention time of the erythema. Histological observations were made on one skin sample at a dosage close to the MRD<sub>50</sub> value. The tests were made at an ambient temperature of 11.5°C and a humidity of 77 percent.

### 2. Results

Because the skin complexions of the volunteers varied, the reactions to the laser illumination also varied. Statistical analysis was made according to skin complexion and the results are shown in Table 3.

Each group of data was subjected to a Chi square test and  $P$  is less than 0.05. The correlations are therefore significant.

Table 3. Erythema on Test Subjects of Three Skin Complexions

	Number of volunteers	Dosage	Power density (W/cm <sup>2</sup> )	Number of shots	Erythema occurrence (%)	Weighted regression results
Light complexion	3	1	49.68	18	6	Regression formula $y = -14.487 + 17.570x$ MRD <sub>50</sub> : 65.519 J/cm <sup>2</sup> Confidence level 95%: 61.295 ~ 70.173 J/cm <sup>2</sup> (Fig. 4)
		2	57.58	18	11	
		3	64.71	18	33	
		4	73.89	18	89	
Yellow skin	5	1	49.68	30	3	Regression formula $y = -14.664 + 18.249x$ MRD <sub>50</sub> : 60.989 J/cm <sup>2</sup> Confidence level 95%: 58.867 ~ 63.188 J/cm <sup>2</sup> (Fig. 5)
		2	57.58	30	37	
		3	64.71	30	63	
		4	73.89	30	93	
Dark complexion	2	1	49.68	12	25	Regression formula $y = -23.137 + 27.744x$ MRD <sub>50</sub> : 52.321 J/cm <sup>2</sup> Confidence level 95%: 46.112 ~ 59.367 J/cm <sup>2</sup> (Fig. 6)
		2	54.88	12	67	
		3	57.58	12	100	

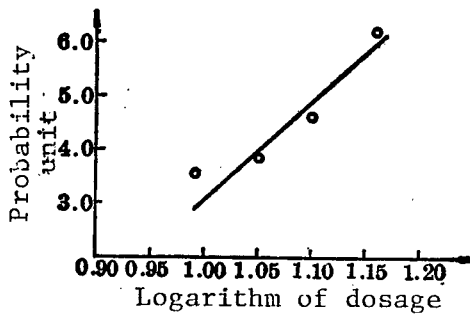

Figure 4. Regression straight line for data from light skin

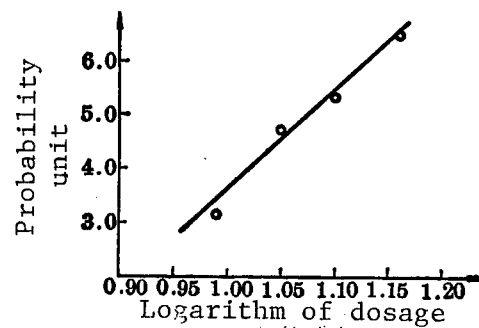

Figure 5. Regression straight line for data from yellow skin

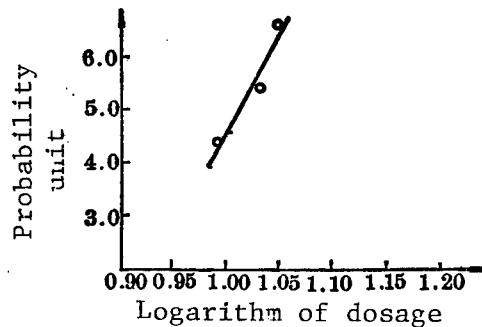

Figure 6. Regression straight line for data from dark skin

### 3. Histological biopsy

No obvious changes were noticed in histological examinations (see Figures 7 and 8).



Figure 7. No obvious changes



Figure 8. No obvious changes

### III. Discussion

#### 1. Comparison with foreign data

For the first time we have experimentally determined the laser damage threshold of the skin of the yellow race. The value falls between those of the white race and those of the black race. The results agreed with a priori expectation and served as useful data for establishing a Chinese standard for laser safety.

2. Both the animal tests and the human tests showed that the content of skin pigment had a definite effect on the damage threshold of laser at 1.06  $\mu\text{m}$  wavelength. At a higher pigment level more laser energy was absorbed and the damage threshold occurred at a lower power density. Dark skin therefore had a lower damage threshold and light skin had a higher damage threshold. The results are shown in Figures 9, 10, and 11.



Figure 9. No obvious changes

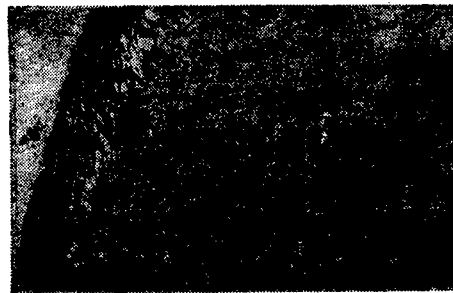

Figure 10. The cytosol of the scaly epithelial cells became foamy, cell nuclei shrank, and capillaries showed slight dilation and edema



Figure 11. Blood vessels showed slight dilation and red blood cells roam outside the cavity

3. For the young white pigs, the value of MRD<sub>50</sub> was 59.385 J/cm<sup>2</sup>, the 95 percent confidence level was 59.950-61.923 J/cm<sup>2</sup>. For the human subjects, the MRD<sub>50</sub> was 52.321-65.519 J/cm<sup>2</sup> and the 95 percent confidence level was 46.112-70.173 J/cm<sup>2</sup>. The animal results are quite close to that of the human and young white pigs are suitable experimental animals for this purpose.

#### 4. Factors affecting the experimental results

##### (1) Level of anaesthesia

For the pigs the skin often displayed congestion before deep anaesthesia and while recovering from anaesthesia. During periods the absorption of the 1.06 μm laser light was greater and erythema were more likely to occur. In deep anaesthesia, the skin turned white and erythema were less likely to occur and easier to fade away quickly. Attention should therefore be given to the level of anaesthesia in order to obtain consistent results.

##### (2) Subjective assessment of erythema

The occurrence and growth of erythema by visual observation can generally be agreed upon but the recession of erythema depends on the observer. The retention time of the erythema is therefore less than objective.

##### (3) Ambient temperature

The observation of erythema may be affected by too high or too low ambient temperatures. The temperature of the laboratory should be controlled to ensure the reliability of the data.

Table 4. Comparison of Experimental Results from This Group and Foreign Materials

表4 本组实验结果与国外资料对比

Group	组别	MRD <sub>50</sub> (J/cm <sup>2</sup> )	95% 可信限 (J/cm <sup>2</sup> )	Confidence Range
Caucasian	高加索人	48~78		
Chinese(lt)	中国人(偏白)	65.519	61.295~70.173	
" (av)	中国人(黄白)	60.989	58.867~68.188	
" (dark)	中国人(偏黑)	52.321	46.112~59.867	
Black	黑人	46~60		

9698/6091

CSO: 8111/1099

## INJURY THRESHOLD OF RUBY LASER IRRADIATION ON HUMAN SKIN

Shanghai ZHONGGUO JIGUANG [CHINESE JOURNAL OF LASERS] in Chinese Vol 12,  
No 10, 20 Oct 85 pp 586-588

[Article by Chen Ji [7115 6619], Wang Jun [3769 6511], Lu Shanfen [4151 0810 5358], Xu Guidao [1776 6311 6670], Shi Liangshun [2457 5328 7311], Qian Huanwen [6929 3562 2429], and Wang Denglong [3769 6260 7893] of the Institute of Radiation Medicine, Academy of Military Medical Sciences]

[Text] Abstract: This paper reports experimental results of human skin exposed to ruby laser light. Statistical analysis of the erythema produced with 24 hours post-exposure showed that ED<sub>50</sub> was about 4.7 J/cm<sup>2</sup>.

Damage thresholds for human skin by ruby laser radiation has been reported in foreign journals.<sup>1-4</sup> However, all the studies were made on the skin of Caucasians or blacks, where the differences were great and not all the results were applicable to the case of the yellow race.

In this study we have extended the experimental investigation on pig skin with a ruby laser to the case of human skin. Observations of the occurrence of erythema and statistical analysis of the data produced a value for the 50 percent erythema reaction dosage.

### I. Experiment

The ruby laser emits a multimode pulse with a pulse width of 0.32 ms, a divergence angle of 28-29 mrad, a maximum output of 18J, and a diaphragm diameter of 0.5 cm. The output energy was stable to within 5 percent and was monitored in real time with a model JNK-1 carbon laser energy meter and a gold-plated inverted cone energy meter. Both devices were calibrated.

The average ambient temperature was  $30.1 \pm 1.4^\circ\text{C}$  and the average relative humidity was  $74.7 \pm 8.6$  percent.

The 15 volunteers were male workers of the laboratory. They were all ethnic Han and their age range was  $39.5 \pm 8.9$ . Physical examinations and electrocardiograms were made before and after the tests and no abnormal changes were detected. The first illumination spot was 3 cm below the centerline of the fossa cubitale, and the spots were below the first spot and separated

by 2 cm from each other. Five shots were made on each forearm and at different dosages (average 0.52-2.8 J). A total of 10 shots were made on the two forearms. Subjects with different skin complexion were distributed among the five dosage groups in order to obtain the collective 50 percent erythema dosage (ED50). Observations were made immediately after the illumination for skin reaction and erythema. Subsequent observations were made at 2, 12, 24, and 48 hours respectively after the illumination.

## II. Results

### 1. Occurrence of erythema

In this study 152 spots were illuminated at five different dosage levels. Each dosage group had 29-33 sample spots, as shown in Table 1. As can be seen, the erythema occurrence rate decreased with decreasing dosage. The occurrence time of the erythema depended on the dosage level, as shown in Table 2. At a high dosage level, the erythema occurs very quickly and at a low dosage level the occurrence rate was lower. The data show that as the radiation dosage decreased the time for erythema occurrence was delayed.

Table 1. Skin Erythema Occurrence Rate Under Ruby Laser Illumination

Group	Ave. dosage $\pm S_x$ (J/cm <sup>2</sup> )	Ave. absorption $\pm S_x$ (J/cm <sup>2</sup> )	No. of shots	Erythema occur- rence rate (%)
1	14.01 $\pm$ 0.72	8.63 $\pm$ 0.61	29	100
2	7.01 $\pm$ 0.56	4.32 $\pm$ 0.30	30	90
3	5.45 $\pm$ 0.25	3.37 $\pm$ 0.24	33	57.6
4	3.92 $\pm$ 0.31	2.43 $\pm$ 0.24	30	36.7
5	2.63 $\pm$ 0.08	1.62 $\pm$ 0.11	30	6.7

Table 2. Forearm Skin Erythema Occurrence Rate and Subsiding Rate

Group	Occurrence rate (%)		Subsiding rate (%)		
	< 5 min	6 min~1 hr	2~12 hrs	13~48 hrs	> 3 days
1	96.6	3.4	10.3	20.7	69.0
2	66.7	33.3	18.5	48.1	33.4
3	36.8	63.2	47.4	52.6	—
4	27.3	72.7	63.6	18.2	18.2
5	50.0	50.0	100	—	—

### 2. Subsidence of the erythema

For a given length of the observation time after the illumination, the subsiding rate of the erythema depended on the dosage (see Table 2). At a high dosage the retention time was long; for a low dosage, the retention time was short.

### 3. Follow-up observation

The skin reaction was observed after different elapsed times following irradiation. (1) Severe erythematous reaction (20.7 percent of the cases): The skin was raised above the normal surface level and small papules formed. The skin became irritated or blistered. Scabs formed 1-2 days following the irradiation and sloughed off after 6-7 days. In some cases no blisters formed but the skin formed scabs. (2) Less severe erythema: The skin remained flat and no blisters or papules formed. The erythema was initially red in color and became dark red and then purple. The boundaries were clear and the retention time was long. The erythema generally subsided in 4-5 days. (3) Medium reaction: The skin became reddish, the outline was clear, the skin was not raised and no papules formed. The erythema was initially faintly visible and gradually became clear. In the No 2 dosage group only volunteer No 8 showed slight scabbing after 3 days and all the other erythematous reactions were light to very light. No papules or blisters were observed and the skin remained even. The color was initially pink and later turned red. The outline may or may not be clear. For the No 3 and No 4 dosage groups the reactions were light to very light. The erythema was pink in color, often circular in shape with a clear boundary. Two cases of erythema were found in the No 5 dosage group. One occurred within 5 minutes and the other occurred after 30 minutes. Both erythematous reactions were very mild and subsided on the second day, with slight traces of pigment precipitation. In the preliminary tests no erythema was found at a dosage level below  $2.5 \text{ J/cm}^2$  (e.g.,  $2.4 \text{ J/cm}^2$ ). The lower limit in the experiment is therefore chosen to be  $2.6 \text{ J/cm}^2$ .

Calculation of the 50 percent erythema dosage (ED<sub>50</sub>): The experimental data were processed statistically. The Bliss method of weighted regression was used in finding the equation, the ED<sub>50</sub> value and the 95 percent confidence level.

$$\hat{Y} = -0.95293 + 6.05599x$$
$$ED_{50} \approx 4.7 \text{ J/cm}^2$$

The 95 percent confidence level is  $4.217-5.146 \text{ J/cm}^2$ . The chi square test gives  $\chi^2 = 1.8683$ ,  $\chi^2_{0.05} = 7.8045$ , and  $P > 0.05$ . The calculation model and the actually measured values were consistent and the results acceptable (see Figure 1).

### III. Discussion

At the same dosage the absorption of the laser energy and the resulting erythematous reaction varied because the skin reflectivity varied from man to man. In our experiment the forearm skin of the volunteers had a maximum reflectivity of  $43.8 \pm 1.9$  percent for the ruby laser light. The lowest reflectivity was  $32.5 \pm 1.8$  percent and the average was  $38.8 \pm 3.6$  percent. At the highest dosage used the skin with lower reflectivity absorbed more laser energy and showed a more severe reaction in the erythema whereas the skin with a high reflectivity does not. In addition, the darkness of the skin complexion and the reflectivity play an important role in the erythematous reaction.

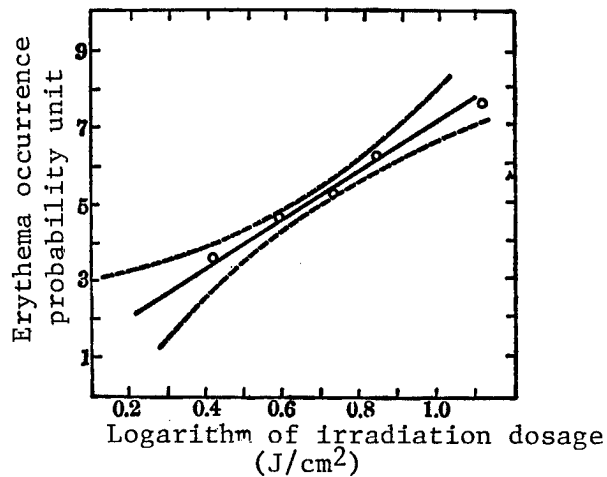

Figure 1. Rate of occurrence and dosage relationship for erythema of human skin irradiated by a ruby laser

Statistical analysis of the experimental data using the Bliss weighted regression method yielded a value of 4.7 J/cm<sup>2</sup> for ED<sub>50</sub>. This differed from the Caucasian ED<sub>50</sub> by a factor of 2.3-4.3 and from the black ED<sub>50</sub> by a factor of 0.5-1.5, as shown in Table 3. This indicates that the skin color of the Chinese is closer to that of blacks and the effective dosage 1.4 J is the same as that of blacks.

Table 3. Comparison of Injury Thresholds of Human Skin Irradiated by Ruby Laser Light

	<u>This work</u>	<u>Blacks</u>	<u>Caucasians</u>
Number of volunteers	15	2	4
Number of shots	152	105	100
Dosage (J/cm <sup>2</sup> )	2.6-14.0	0.5-8.0	5.0-30.0
Skin reflectivity (%)	32-44	30-41	52-62
Erythema occurrence rate (%)	57.9	32.4	72
ED <sub>50</sub> (J/cm <sup>2</sup> )	4.7	2.2-6.9	11-20

The ANSI regulation states that the maximum permissible energy density (MPE) of the skin for visible light radiation is 150 mJ/cm<sup>2</sup>. The ED<sub>50</sub> obtained in this experiment was 31 times the MPE value. The skin damage threshold of the Chinese is therefore close to the MPE value. This should be considered in establishing laser safety protection.

The authors acknowledge the contribution of Tang Zhongming [3282 0112 2494] in the statistical analysis of the data.

#### REFERENCES

1. J.G. Kuhn, et al., "Laser Injury in Skin," Lab. Invest., 1967, 17, No 1, 1-13.

2. L. Goldman, "The Skin," ARCH. ENVIRON. HEALTH., 1968, 18, 434.
3. W.H. Parr, "Skin Lesion Threshold Values for Laser Radiation as Compared With Safety Standards," U.S. Army Medical Research Laboratory Report, 1964, Feb. 24, 813.
4. J.P.G. Williams, et al., "Final Report of Investigations of Laser Skin Hazards," AD-735794 (p 8161), 1971.
5. R.J. Rockwell, et al., "Research on Human Skin Laser Damage Thresholds," AD A-012703 (p 8947), 1974.
6. Wang Jun [3769 6511], et al., "Injury Threshold of Ruby Laser Irradiation on Pig Skin," this issue, p 631.

9698/6091

CSO: 8111/1099

## ACUTE INJURY THRESHOLD LEVEL OF CO<sub>2</sub> LASER LIGHT FOR SKIN OF YELLOW RACE

Shanghai ZHONGGUO JIGUANG [CHINESE JOURNAL OF LASERS] in Chinese Vol 12, No 10, 20 Oct 85 pp 589-591, 588

[Article by Shi Hongmin [0670 1347 2404], Li Jishi [2621 3444 2514], Tan Yankang [6223 1693 1660], Luo Panxiang [5012 3140 4382], Chen Zhongben [7115 0112 2609], Xie Xingbing [6200 2622 0393], and Yuan Yuehuan [5913 1878 2970] of Zhongshan Medical University, Guangzhou]

[Text] Abstract: Acute injury threshold level MRD<sub>50</sub> of CO<sub>2</sub> laser light for the skin of eight white piglets was measured. On the basis of the animal experiments, the same measurement for the skin of six yellow people was made. MRD<sub>50</sub> was found to be 2.3 J/cm<sup>2</sup>. The skin of five volunteers was exposed to the above energy densities, and histological examination found that capillaries were expanded and filled with erythrocytes and light edema, but there was no significant change of cuticle. This indicates that the MRD<sub>50</sub> erythematous reaction is minimal and reversible.

By studying the erythematous reaction of the skin of young pigs and human subjects irradiated by normally incident CO<sub>2</sub> laser light, we have determined the injury threshold level MRD<sub>50</sub> (i.e., the radiation level for 50 percent reaction) and provided experimental data for establishing a laser safety standard.

### I. Experimental Setup

A CW CO<sub>2</sub> laser (10.6 μm) with a fundamental mode output was used in the irradiation of the skin of 5 kg young pigs and the yellow race skin and the erythematous reactions were observed. The experimental setup is shown in Figure 1.

The output power of the CW CO<sub>2</sub> laser was 15-30 W and stable to within 4 percent. The beam was introduced into the optical path by the gold-plated reflection mirror #1 and the power monitored. The beam was reflected by the total reflection mirror #2, passed through the closed optical path consisting of the germanium lens (with antireflection coating) and the diaphragm and impinged on the animal or human skin. In order to control the radiation flux, the power at the exit of the diaphragm was calibrated for each laser output power and diaphragm to lens distance before the experiment. Before

the irradiation of the animal or human skin, the power was again measured with a high-speed power meter in order to avoid the effects of other factors. Exposure time was controlled by an electric shutter and monitored by a photodiode and recorded by a digital time recorder to assure repeatability of the measurement.

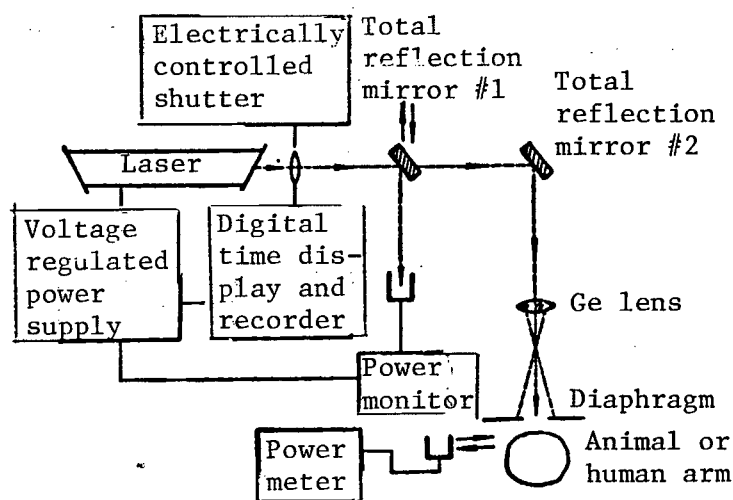

Figure 1. Experimental setup

## II. Experimental Conditions and Data

The measurements were made at an ambient temperature of  $20 \pm 5^\circ\text{C}$  and a relative humidity not higher than 80 percent.

Based on the results obtained from young pigs, the injury threshold of the yellow race skin for  $\text{CO}_2$  laser was determined under the same experimental conditions. Using the modified Kou method, the  $\text{MRD}_{50}$  value of each volunteer was first determined. The exposure time was 1 second, the light spot diameter was 0.5 cm, and the erythema observation time was 5 minutes. Five exposure levels in geometric ratio were then selected. The minimum level  $D_n$  was chosen so that erythema appeared on all subjects but disappeared after 5 minutes. The maximum level  $D_m$  was chosen so that most of the erythema remain after 5 minutes and visual observation showed no edema and no skin abnormalities remain after the disappearance of the erythema.

In this study measurements were made on six volunteers--three females and three males--in the 20-21 age group. The irradiation location was the side of the forearm, as shown in Figure 2. The lattice spacing was 2 cm and the skin outside the marked lattice was used for preliminary tests. The numbers 1-5 inside the lattice represent five different exposure levels, and the layout of the dosage was based on symmetry and balance requirements. For each dosage 30 shots were made. After the exposure, careful observations were made to determine the appearance and disappearance time of the erythema. The number of remaining erythema was recorded after 5 minutes and the results are shown in Table 1.

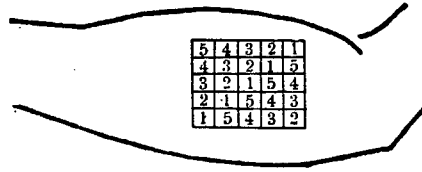

Figure 2. Exposure spots on the side of the forearm

Table 1. Erythema Reaction Number  $r$  at Different Dosages

Volunteer No.	Dosage level ( $J/cm^2$ )				
	2.48	2.33	2.19	2.06	1.94
2 (M)	5	4	2	0	0
3 (F)	5	4	2	1	0
4 (M)	5	3	2	1	0
5 (M)	5	3	3	2	0
6 (F)	4	3	1	0	0
7 (F)	5	4	2	1	0
$\Sigma$	29	21	12	5	0

Using a weighted regression method,<sup>1</sup> the relationship between the probability unit  $y$  and the logarithmic dosage  $x = \log D$  was found:

$$y - \bar{y} + b(x - \bar{x}) = 40.733x - 9.318$$

This relationship is shown graphically in Figure 3. The significance index of the slope  $b$  is  $g = 0.074 < 0.1$ , and

$$MRD_{50} = 2.3 J/cm^2$$

The 95 percent confidence level is 2.2-2.3  $J/cm^2$ .

Under identical conditions, the skin on the side of the forearms of five volunteers (21-46 years old) was irradiated at a dosage level of  $MRD_{50} = 2.3 J/cm^2$ . Samples were taken 5 and 30 minutes after the  $CO_2$  laser exposure for histological examinations. The results (see Figure 4) showed capillary dilation in the papillary layer of the corium, a few capillaries were filled with erythrocyte, and blood vessels close to the shallow layer of the corium and close to the sweat gland were also dilated. The cuticle showed no obvious changes. In individual biopsies, slight prickle cell edema and basal-cell liquidation (bubble formation) were observed. For the specimens taken 30 minutes after the laser exposure, most cases showed slight blood vessel dilation, lessening of congestion, and a few lingering prickle cell and basal-cell edema. Histological studies showed that the injuries at this dosage are reversible threshold damages.

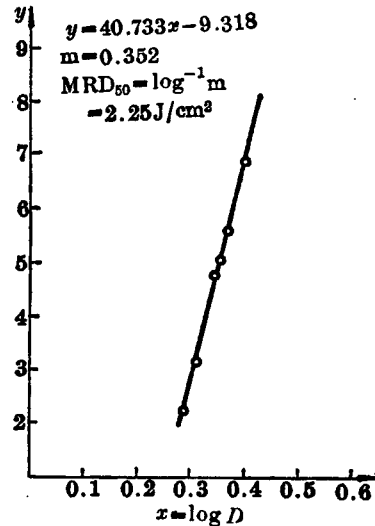

Figure 3. Relationship between the probability and the logarithmic dosage

### III. Results and Discussion

The result of this study is that the acute injury threshold of CO<sub>2</sub> laser for the skin of the yellow race is determined to be MRD<sub>50</sub> = 2.3 J/cm<sup>2</sup>. This is slightly lower than the MRD<sub>50</sub> of 2.8 J/cm<sup>2</sup> obtained by Rockwell and Goldman for the white and black races. The main cause for this discrepancy is that in our experiment the standard time for erythema observation is 5 minutes whereas Goldman used 60 minutes. Our animal tests data showed that MRD<sub>50</sub> increases somewhat when the observation time is prolonged. We have tested a 45-year-old male volunteer using 30 minutes as the standard time for erythema observation and obtained MRD<sub>50</sub> = 3.1 J/cm<sup>2</sup> with the modified Kuo method. This value is even larger than 2.8 J/cm<sup>2</sup>. This is because our spot area is 0.196 cm<sup>2</sup> and that of Goldman is 0.865 cm<sup>2</sup>. In general a small spot area is associated with more heat loss and therefore a higher MRD<sub>50</sub> value.

We measured MRD<sub>50</sub> = 3.7 J/cm<sup>2</sup> ( $\phi = 0.5$  cm, 1 sec) for the eight young pigs. This is greater than the MRD<sub>50</sub> of human skin because the transmissivity for the CO<sub>2</sub> laser light of the young pig skin is greater than that of human skin<sup>3</sup> and the reflectivities fall within 5 percent of each other. The pig skin therefore absorbs less light energy than the human skin and has a greater threshold value. The difference is less than a factor of 2.

In terms of accuracy, Rockwell et al. obtained their MRD<sub>50</sub> graphically using two data points on a normal log paper. In this work, three dosage levels were chosen between the maximum and the minimum dosage and the dosages were in the order of a geometric series. There were five points on the graph and the reliability was therefore better. The results obtained are sensible and can be used as reference data in establishing a laser safety standard.



(a) Sample taken 5 minutes after exposure. Shallow layer capillaries and capillaries in papilla corium are dilated and congested.

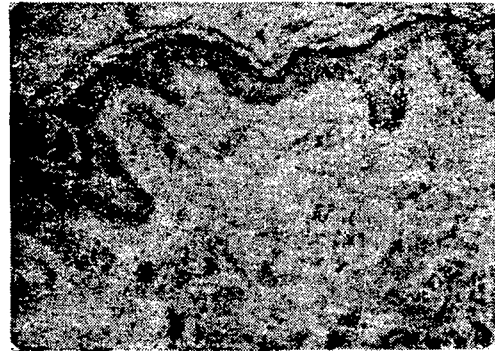

(b) Sample taken 5 minutes after exposure. More obvious capillary dilation and congestion.

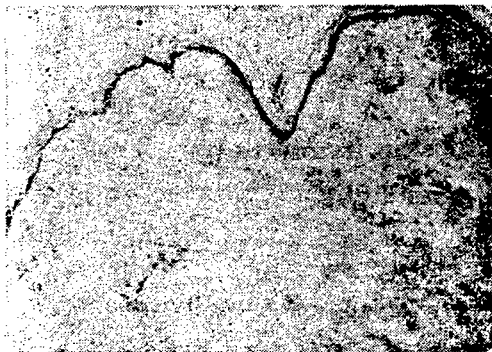

(c) Sample taken 5 minutes after exposure. Capillary dilation and congestion, prickle cell edema.



(d) Sample taken 30 minutes after exposure. Lessening of capillary dilation and congestion.

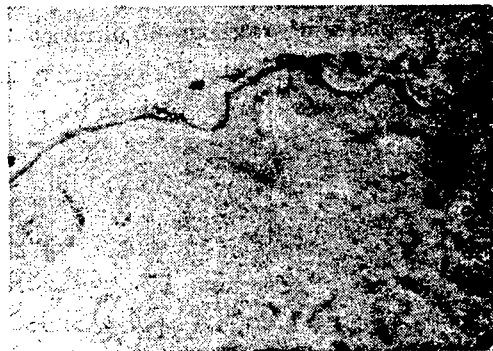

(e) Sample taken 30 minutes after exposure. Lessening of capillary dilation and congestion.

Figure 4. Physiodermatological changes after exposure to CO<sub>2</sub> laser irradiation (12x10 magnification)

#### REFERENCES

1. Zhou Haijun, et al., "Methods of Biological Testing Statistics," People's Sanitation Publishing Company, 1983.
2. Sun Ruiyuan, "Quantitative Pharmacology," 1963.
3. L. Goldman and J.R. Rockwell, Jr., "Laser in Medicine," New York, Gordon Press, 1971.

9698/6091

CSO: 8111/1099

STUDY OF INJURY THRESHOLD OF SKIN IRRADIATED WITH 265 nm PULSED LASER LIGHT

Shanghai ZHONGGUO JIGUANG [CHINESE JOURNAL OF LASERS] in Chinese Vol 12, No 10, 20 Oct 85 pp 592-596

[Article by Li Zhaozhang [2621 0340 3864], Wu Jianu [0702 1367 1166], and Gai Baokang [5556 1405 1660] of the Laser Research Laboratory, Shanghai No 2 Medical University, and Zhou Yan [0719 5888] of Jiaotong University]

[Text] Abstract: An investigation of erythema of the skin irradiated with 265 nm pulsed laser is presented. Two phases of reactions of ultraviolet erythema--immediate and delayed--were clearly observed in our experiment. The probability statistical analysis indicated that the minimal dose of 50 percent perceptible redness occurrence rate of the pig skin is 22.0 mJ/cm<sup>2</sup>.

In general, ultraviolet radiation may be divided into three wavelength ranges: UVA (315-400 nm), UVB (280-315 nm), and UVC (200-280 nm). Since photons in these three ranges have different energy, they induce different biological reactions. Photons in UVC have a greater energy and can easily cause photochemical reactions. In the early part of this century researchers studied the effects of UVC on the skin. Later, Rottier (1953) and Magnus (1964) measured the minimum redness dosage (MRD) of ultraviolet of various parts of the human body. Their results (see Table 1) showed that UVC was more likely to cause redness than UVB. In order to investigate the effects of UV laser on the skin, we used a Nd:YAG quadruple frequency laser as the source and white pigs as a control animal to measure the injury threshold of 265 nm laser. Similar experiments have not been reported here or abroad. The test results may be used as a preliminary data base for establishing China's laser safety standard on the maximum permissible dosage (MPE) of UV laser on the skin.

Table 1. Ultraviolet Laser MRD of Human Skin

Investigator and date	Location	Area	Number of subjects	Observa- tion time	UVC (nm)	UVB (nm)
					MRD	MRD
Rottier (1953)	Arm	0.5x8 mm <sup>2</sup>	7	6-14 hrs after exposure	257 nm	297 nm
					1130	1697
					mW/sterad	mW/sterad
Magnus (1964)	Back	3x10 mm <sup>2</sup>	13	3-8 hrs after exposure	260 nm	300 nm
					25.12	50.12
					mJ/cm <sup>2</sup>	mJ/cm <sup>2</sup>

## I. Experimental Setup and Method

A Q-switched Nd:YAG laser was used as the light source. The wavelength of the quadrupled frequency was 265 nm, the pulse width was 9 ns, the maximum single pulse energy was 20 mJ, the output stability was within  $\pm 5$  percent, and the divergence angle of the beam was 0.36 mrad.

The optical path and the setup is shown in Figure 1. Two energy monitors were used: a model NJ-NI and a RJ7200 (made in USA). The dosages were computed based on a beam splitting ratio of  $K = 0.27 \pm 0.019$  and the energy measured in real time.

The laboratory conditions were  $11.2 \pm 0.8^\circ\text{C}$  and  $72.3 \pm 8.1$  percent relative humidity.

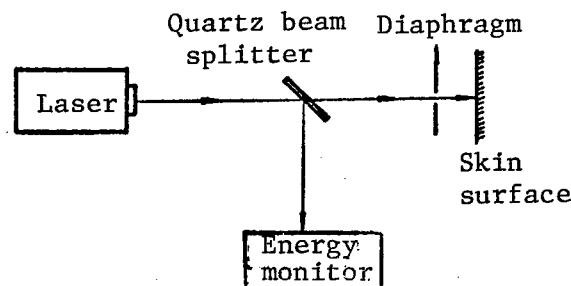

Figure 1. Schematic diagram of the experimental setup

The test animals were three 4.5 kg Shanghai white pigs. The animals were anaesthetized 2 hours before the test. Forty 2cm x 2cm squares were painted on shaven skin 2cm from the spine. Each square received one laser shot at normal incidence.

The observation of the erythema was made visually, according to the criteria in Table 2. Each irradiation group was followed by the conventional (H.E. Stain) histological test. Some electron-microscopy studies were also made for the MRD group.

Table 2. Criteria for Erythema

Grade	Visual observation	Histological examination
0	No reaction	Normal
±	Very light redness, no obvious boundary	Cuticle normal, hypodermal capillary dilation and congestion
+	Light redness, visible boundary	Normal cuticle, hypodermal capillary dilation and congestion, exudation of red blood cells
++	Medium redness, obvious boundary, edema	Hypodermal capillary dilation and congestion, edema of cuticular cells, some shrinkage of nuclei
+++	Redness, boundary may be accompanied by edema	Same as ++ grade; in addition, the collagen fibers in the corium thickens and the cuticle becomes puffy

## II. Experimental Results and Analysis

A total of 224 shots were made, 21 points were examined histologically, and 203 points at 6 dosages were analyzed statistically. Tables 3 and 4 show the erythematous reaction to 265 nm laser pulses.

Table 3. Transient Erythematous Reaction of Pig Skin to 265 nm Laser Irradiation

Group	Ave. dosage (mJ/cm <sup>2</sup> ) ± std. dev.	No of shots	Transient erythema			
			Occur- rence %	Time of occurrence (sec)	Duration (min,sec)	Grade
1	13.66 ± 0.13	31	-	-	-	-
2	16.61 ± 0.64	31	19.35	15" ~ 23"	30" ~ 5'	±-
3	20.21 ± 0.33	33	39.39	12" ~ 18"	2' ~ 10'	±
4	24.23 ± 0.70	34	67.64	6" ~ 14"	2' ~ 12'	±+
5	29.04 ± 1.22	34	88.23	4" ~ 12"	2' ~ 15'	+-
6	39.44 ± 2.03	40	100	0 ~ 10"	5' ~ 20'	+-

Table 4. Retaining Erythematous Reaction of Pig Skin to 265 nm Laser Irradiation

Group	Ave. dosage (mJ/cm <sup>2</sup> ) ± std. dev.	No of shots	No of erythema after 24 hrs	Delayed erythema occurrence rate after 24 hrs (%)	Highest grade reached in 24 hours
1	13.66 ± 0.13	31	4	12.90	±
2	16.61 ± 0.64	31	8	25.81	±
3	21.21 ± 0.33	33	14	42.42	+
4	24.23 ± 0.70	34	20	58.82	±+
5	29.04 ± 1.22	34	25	73.53	++
6	39.44 ± 2.03	40	36	90.00	+++

The transient erythema produced by the 265 nm laser pulses had a maximum persistence time of 20 minutes and may expand to a diameter of 5-8 mm. Delayed erythema occurred at different time for different dosage groups and the redness grade also vary. Figure 2 shows the variation of the erythematous reaction with time. After 48 hours the erythema in groups 1-4 had all disappeared and pigment deposits were not pronounced. In groups 5 and 6 some shots had light brown pigment deposits lasting 1-2 days. Group 6 had blisters on about 25 percent of the shots.

Based on histological examinations under an optical microscope, the skin of the first group remained basically normal after irradiation. Skin in the second, third, and fourth dosage groups showed various degrees of dilation and congestion of the hypodermal capillaries. In group 4, a few cuticular cells showed light edema and the prickle cells showed ambiguous boundaries. In group 5 after 24 hours, there were also signs of cuticle deterioration, edema within cuticle cells, and nuclei shrinkage. The reaction in group 6

was the most severe. Cavities formed in cuticle cells, basal cell arrangement became locally randomized, and collagen fibers of deep layer corium cells thickened. The histological examinations made 2 hours after irradiation revealed basically the same results except the indications of cell nuclei shrinkage, edema within the cells, and collagen fiber thickening were less obvious. Electron microscope examinations of the groups 3 and 4 skin 24 hours after irradiation showed that some of the chondriosome ridges of the basal cell had become blurred or disappeared, some of the chondriosome had enlarged, and the spacing between the cells had increased. Electron microscope examinations made 2 hours after the shots revealed no abnormality (see Figure 3).

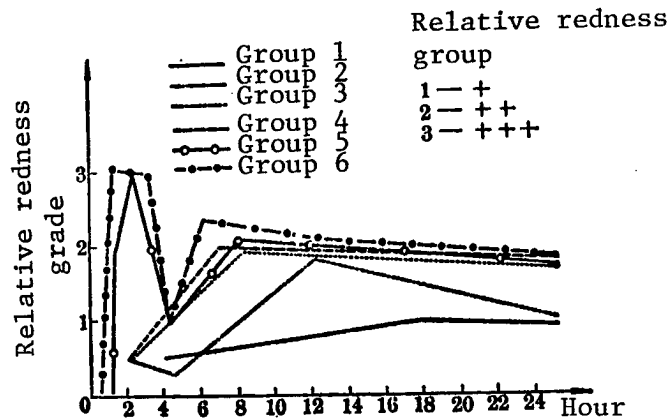
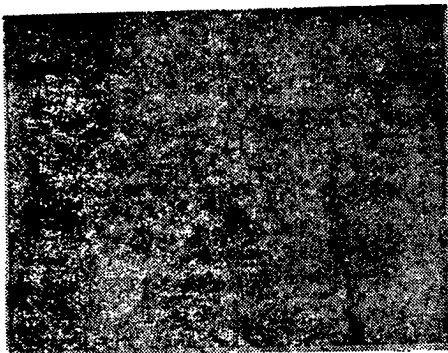
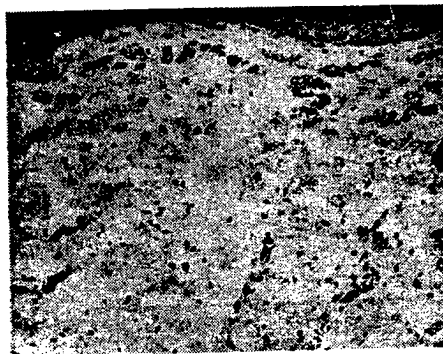

Figure 2. Erythematous reaction as a function of time at various radiation dosages



(a) Histological study of group 4 at 2 hours after irradiation. Dermal capillaries dilated and congested.



(b) Histological study of group 5 at 2 hours after irradiation. Dermal capillaries dilated and congested.

[Figure 3 continued on following page]

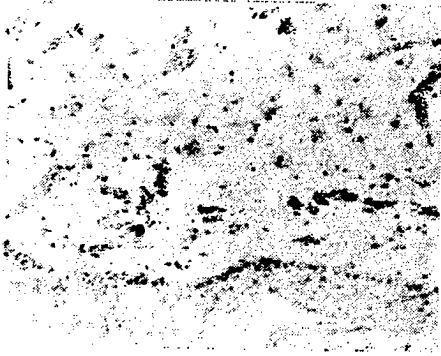

(c) Histological study of group 3 at 24 hours after irradiation. Dermal capillaries dilated and congested.

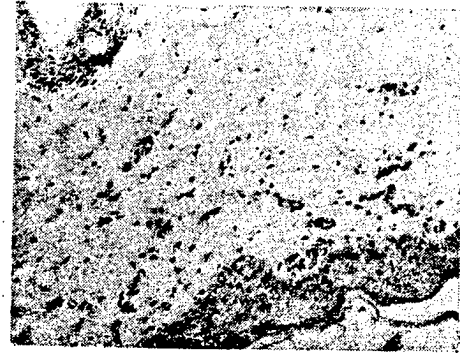

(d) Histological examination of group 4 at 24 hours after irradiation. Blood vessels dilated and congested. Some basal cells showed slight edema.

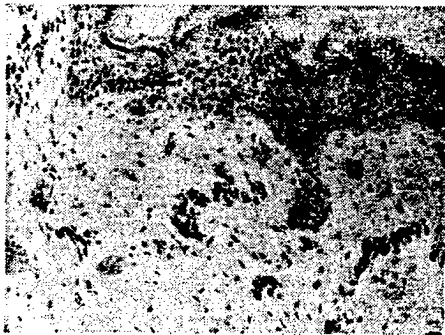

(e) Histological examination of group 5 at 24 hours after irradiation. Dermal capillaries dilated and congested, edema within cuticle cells and some cell nuclei showed shrinkage. Cuticle became puffy.

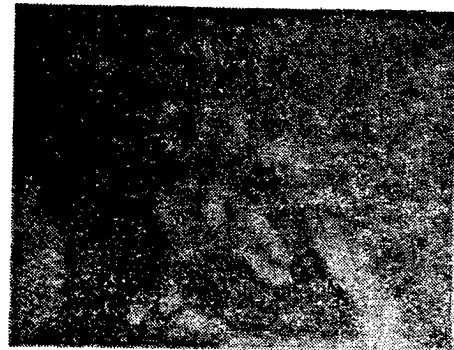

(f) Histological examination of group 6 at 24 hours after irradiation. Bubbles in cuticle cells, collagen fibers in deep dermal layer thickened.



(g) Electron microscopic examination of group 4 after 2 hours. Cuticle cells remained normal.

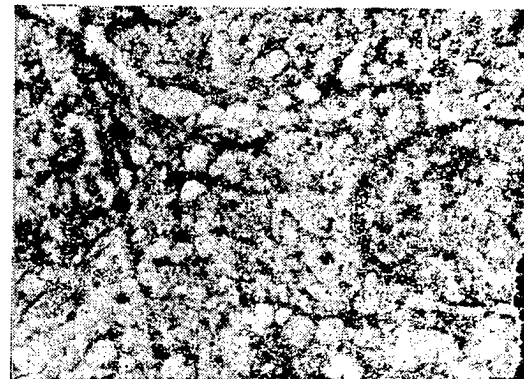

(h) Electron microscope examination of group 4 after 24 hours. Prickle cell spacing increased, bridge point blurred, chondriosome ridge blurred or disappeared.

Figure 3

Table 5 and Figure 4 show the MRD<sub>50</sub> and the 95 percent confidence limit of the pig skin irradiated by 265 nm laser pulse as obtained by the visual method and by the weighted regression method. The equation obtained by the weighted regression method was tested for  $\chi^2$  and the  $\chi^2$  value of 0.0836 was much less than the value of  $\chi^2(3)0.05$ . The equation is therefore acceptable.

Table 5. Injury Threshold Statistics of White Pig Skin Irradiated by 265 nm Laser Pulses

	<u>Visual method</u>	<u>Weighted regression method</u>
Regression equation		$y = 5.2066x - 1.9892$
MRD <sub>50</sub> (mJ/cm <sup>2</sup> )	22.13	22.00
95% confidence limit (mJ/cm <sup>2</sup> )	19.79 ~ 24.75	20.20 ~ 23.94

Note:  $x$  is the logarithm of the dosage,  $y$  is the erythema occurrence probability

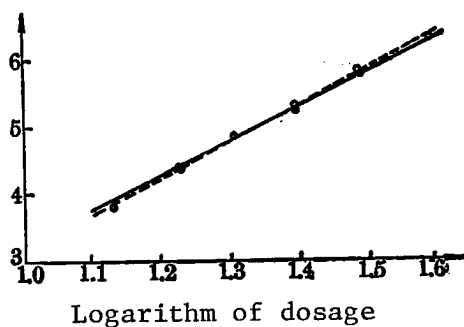

Figure 4. Relationship between erythema occurrence probability and logarithm of the dosage  
Solid line by visual method; dashed line by weighted regression;  
open circles are experimental points; solid dots are computed values

### III. Discussion

#### 1. Comparison of UVC and UVB

Both UVC (200-280 nm) and UVB (280-315 nm) cause transient and delayed erythematous reactions in pig skin. When we used 265 nm pulsed laser and 308 nm excimer laser in irradiating the pig skin, the erythematous reactions were very obvious and the behaviors were not the same. The transient erythema caused by the 265 nm laser pulse lasted a longer time than that produced by 308 nm laser pulse. Both required a certain period of time to induce delayed erythema, characteristic of photochemical reactions. The delayed erythema generated by the 265 nm laser occurred 0.5-4.5 hours after the irradiation, while that produced by the 308 nm laser occurred 5-18 hours after the

irradiation. Possibly this had something to do with the higher photon energy of the 265 nm laser, a greater photon energy causes a faster photochemical reaction. Moreover, the observed behavior of the delayed erythema as a function of time seemed to imply that several photochemical materials were coming into play at different stages of the reaction. This agrees with the viewpoint reported in foreign journals.

Ultraviolet erythema is the result of photochemical reactions. The heat generated in the skin is less than that produced by a thermal effect but heat is nonetheless generated. We considered the heat effect and measured the skin temperature with a model 7151 semiconductor thermometer made by the Shanghai Medical Equipment Plant. We found that, as the radiation dosage increased, the temperature of the erythematous skin was higher than the unaffected skin 1 hour after the shot was 29.1°C whereas the temperature of the unaffected skin was 27.8°C. This also shows that the laboratory temperature should be kept constant during such experiments.

## 2. Safety standard of UV laser

According to the UV radiation health standard issued by the World Health Organization in 1979 and the laser safety standards issued recently by ANSI and IEC, the maximum permissible exposure of the skin for 260-270 nm ultraviolet radiation is 3 mJ/cm<sup>2</sup>. The MPE for 308 nm UV with a pulse width of 15 ns is 6.2 mJ/cm<sup>2</sup>. Based on our experimental results, the injury thresholds (MRD<sub>50</sub>) are 22.0 mJ/cm<sup>2</sup> for 265 nm, and 53.84 mJ/cm<sup>2</sup> for 308 nm. The computed MRD<sub>50</sub>/MPE ratios are 7 and 9 for 265 nm and 308 nm respectively. These data show that the MPE safety factor based on animal experiment should be at least 10. Since the UV section of the spectrum has significant biological effects, more animal tests should be made using short UV laser pulses in order to assume the reliability of the laser safety standard.

9698/6091

CSO: 8111/1099

## INVESTIGATION OF LASER INJURY THRESHOLD OF SKIN

Shanghai ZHONGGUO JIGUANG [CHINESE JOURNAL OF LASERS] in Chinese Vol 12,  
No 10, 20 Oct 85 pp 597-599, 596

[Article by Wu Qingzhen [0702 1987 6297] and Dong Peiyong [6772 0160 5391] of the Department of Dermatology, Ruijin Hospital, Shanghai No 2 Medical University and Zhuo Ruipong [0587 3843 7720], Hu Qingshen [5170 1987 3088], Li Zhaozhang [2621 0340 3864], Gai Baokang [5556 1405 1660], Jiang Lanying [3068 5695 5391], and Wu Jianu [0702 1367 1166] of the Laser Research Laboratory, Shanghai No 2 Medical University]

[Text] Abstract: This paper reports the research results on laser injury threshold of skin irradiated by 200  $\mu$ s pulsed Nd glass laser, CO<sub>2</sub> laser and 488 nm Ar ion laser light.

The study of laser injury threshold of the skin has been reported since 1969, when Rockwell and Goldman of Cincinnati University first reported the minimum reaction dosage of five kinds of laser radiation for skin of Caucasians. In 1974 they reported more detailed injury threshold results of the skin of Caucasians and blacks by six different lasers. The injury thresholds were given in terms of the dosage corresponding to a 50 percent probability for producing a minimum injury (erythema) reaction, or, MRD<sub>50</sub>. In this paper we report the research results on laser injury thresholds of the skin of young pigs and of humans by Nd:glass laser, CO<sub>2</sub> laser and argon ion laser.

### I. 200 $\mu$ s Pulsed Nd:glass Lasers

Figure 1 shows the experimental light path for the pulsed Nd:glass laser. The maximum energy output of the laser is 7 J, the stability is better than  $\pm 5$  percent, the pulse width is 200  $\mu$ s, and the repetition rate is one shot in every 5 minutes.

#### 1. Animal Experiment

The test animals were young Shanghai pigs and hybrid colored pigs. A grid of 2 cm<sup>2</sup> lattice was painted on the skin of the chest and abdomen 2 cm from the spine, as shown in Figure 2.

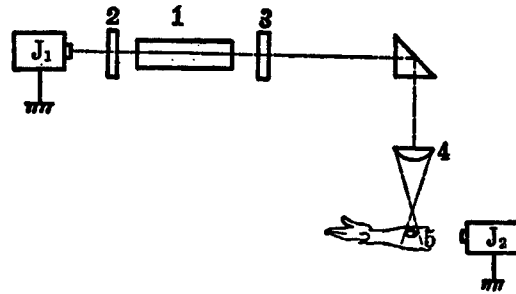

Figure 1  
 1--Nd glass; 2,3--Reflection mirrors; 4--Focusing lens (f/45);  
 5--Skin to be irradiated; J<sub>1</sub>--Real time energy monitor; J<sub>2</sub>--  
 Energy meter for output beam

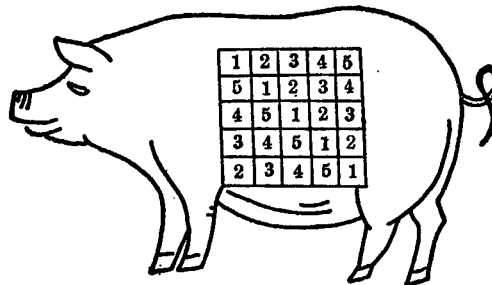

Figure 2. Fifty squares are marked on the skin of each pig

The energy density was determined in some preliminary test shots. For the hybrid pigs the energy density used was 2.753-11.562 J/cm<sup>2</sup>. Tests were made at five energy density levels and the results are shown in Table 1. The MRD<sub>50</sub> value was based on local erythema without edema or blister and persistent for more than 5 minutes.

Table 1. Results of Hybrid Pigs Irradiated by Nd:glass Laser

<u>Group</u>	<u>Energy density</u>	<u>No of shots</u>	<u>No of erythema</u>	<u>Pathological examination</u>
1	2.45 J/cm <sup>2</sup>	30	4	(-)
2	4.267 J/cm <sup>2</sup>	30	13	(-)
3	5.891 J/cm <sup>2</sup>	30	20	(-)
4	9.415 J/cm <sup>2</sup>	30	26	20%(+)
5	11.755 J/cm <sup>2</sup>	30	30	70%(+)

In Table 1, a "-" sign in the pathological examination column means no pathological changes, a "+" sign means the pathological changes are confined to the cuticular layer. The data were processed using a weighted linear regression method:

Regression equation:  $y = 2.121 + 4.326 x$   
 MRD<sub>50</sub>: 4.628 J/cm<sup>2</sup>  
 95 percent confidence level: 4.071 - 5.261 J/cm<sup>2</sup>  
 $\chi^2$  test:  $P < 0.05$

## 2. Injury threshold of human skin

The irradiation scheme is shown in Figure 3. The inner surface skin of the two forearms 5 cm above the wrist to the elbow was used, 30 2x2.5 cm<sup>2</sup> grids were marked on the skin surface. Each volunteer was irradiated at a dosage level close to the MRD<sub>50</sub> value. Skin specimens were taken for erythema that persisted more than 5 minutes after the laser shots and pathological examinations were made using H.E. staining. The results are shown in Table 2.

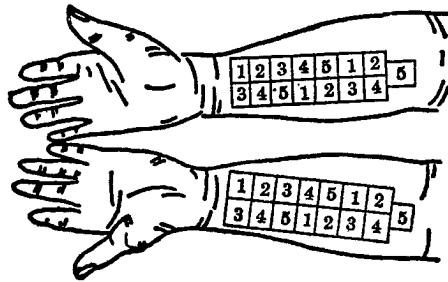

Figure 3

Table 2. Statistics of Erythema Occurrence With 5 Minutes or Longer Persistence

Group	Energy density	No of shots	No of erythema	Pathological examination
1	3.422 J/cm <sup>2</sup>	60	1	
2	5.891 J/cm <sup>2</sup>	60	7	3 cases of (-)
3	9.751 J/cm <sup>2</sup>	60	24	6 cases of (-)
4	12.284 J/cm <sup>2</sup>	60	41	3 cases of (-)
5	15.263 J/cm <sup>2</sup>	60	51	
6	17.435 J/cm <sup>2</sup>	60	59	

The data were analyzed using a weighted linear regression method:

Regression equation:  $y = -0.686 + 5.705 x$   
 MRD<sub>50</sub>: 9.921 J/cm<sup>2</sup>  
 95 percent confidence level: 9.269 - 10.618 J/cm<sup>2</sup>  
 $\chi^2$  test:  $P < 0.05$ , acceptable

## II. Injury Threshold of CO<sub>2</sub> Laser\*

Figure 4 shows the experimental setup. The maximum output power of the laser was 20 W, the divergence angle was less than 3 mrad, the power stability was  $\pm 2$  percent, and the laser was operated in its fundamental mode.

\*Xiao Yurui of the burn ward, Ruijin Hospital, Shanghai No 2 Medical University participated in this experiment.

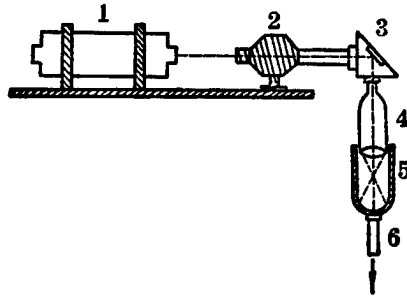

Figure 4

1--CO<sub>2</sub> laser tube; 2--Fixture; 3--Light guide articulation arm;  
4--Germanium lens f/35; 5--Telescope tubing; 6--Irradiation  
aperture 5 mm diameter

### 1. Animal experiment

Table 3 shows the CO<sub>2</sub> laser test results on animals. The value of MRD<sub>50</sub> was obtained from the occurrence rate of the erythema that persisted 5 minutes.

Table 3. CO<sub>2</sub> Laser Test Results of Young White Pigs

<u>Group</u>	<u>Power density</u>	<u>No of shots</u>	<u>No of erythema</u>	<u>Pathological changes</u>
1	1.281 W/cm <sup>2</sup>	100	2	(-)
2	1.734 W/cm <sup>2</sup>	100	17	(-)
3	2.218 W/cm <sup>2</sup>	100	42	(-)
4	2.877 W/cm <sup>2</sup>	100	66	20%(+)
5	3.593 W/cm <sup>2</sup>	100	95	60%(+)

Note: "-" indicates no abnormalities or light edema of shallow hypodermal layer.

"+" indicates changes limited to the cuticle.

The data were analyzed using a weighted linear regression method:

$$\text{Regression equation: } y = 2.173 + 7.464 x$$

$$\text{MRD}_{50}: 2.391 \text{ W/cm}^2$$

$$95 \text{ percent confidence level: } 2.290 - 2.496 \text{ W/cm}^2$$

$$x^2 \text{ test: } P < 0.05, \text{ acceptable}$$

### 2. Human skin injury threshold for CO<sub>2</sub> laser

Ten volunteers were tested at dosages close to their MRD<sub>50</sub> level. Using the data shown in Table 4, a linear regression analysis yielded a MRD<sub>50</sub> of 2.4-2.9 W/cm<sup>2</sup>. Skin samples were taken from five volunteers exposed at 2.467 W/cm<sup>2</sup> and interavital microscopy were performed on five volunteers exposed at 2.757 W/cm<sup>2</sup>. Seven-tenths of the slides showed shallow hypodermal capillary dilation and congestion and no other abnormalities were observed.

Table 4. CO<sub>2</sub> Laser Injury Results

Group	Power density	No of shots	No of erythema	Pathological changes
1	2.176 W/cm <sup>2</sup>	60	3	
2	2.467 W/cm <sup>2</sup>	60	17	5 cases of (-)
3	2.757 W/cm <sup>2</sup>	60	35	5 cases of (-)
4	3.047 W/cm <sup>2</sup>	60	49	
5	3.337 W/cm <sup>2</sup>	60	59	

Weighted linear regression of the data yielded:

Regression equation:  $y = -2.861 + 18.446 x$   
 MRD<sub>50</sub>: 2.668 W/cm<sup>2</sup>  
 95 percent confidence level: 2.607 - 2.730 W/cm<sup>2</sup>  
 $\chi^2$  test:  $P < 0.05$ , acceptable

### III. Skin Injury Threshold of Ar Ion Laser

Figure 5 shows the experimental setup. The output power (at 488 nm and 514.5 nm) was 5-6 W, the power at 488 nm was 1.5 W [sic], the stability was better than 3.5 percent and the beam divergence angle was 2.5 mrad.

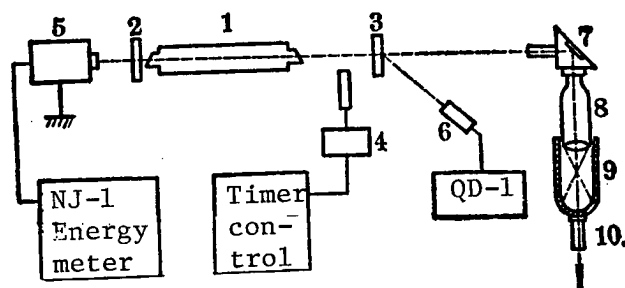

Figure 5

1--Argon laser tube; 2,3--Reflecting mirrors; 4--Time control relay; 5--Model NJ-1 energy meter; 6--Photosensitive element; 7--Light guiding articulation arm; 8--f/45 lens; 9--Lens tube (with movable outer sleeve); 10--5 mm diameter irradiation diaphragm

#### 1. Animal experiment

In the dosage range of 3.918-9.86 W/cm<sup>2</sup>, only pink spots were observed on the skin and the redness lasted less than 2 minutes. The hybrid pigs were exposed to 3.337-8.27 W/cm<sup>2</sup> and uniform erythematous reactions were observed after the shots. The redness lasted 5 minutes and the results are listed in Table 6.

Table 6. Argon Laser Test Results on Hybrid Pigs

<u>Group</u>	<u>Power density</u>	<u>No of shots</u>	<u>No of erythema</u>	<u>Pathological examination</u>
1	3.337 W/cm <sup>2</sup>	30	0	
2	3.918 W/cm <sup>2</sup>	30	3	(-)
3	4.788 W/cm <sup>2</sup>	30	12	(-)
4	5.659 W/cm <sup>2</sup>	30	20	Cuticle (+)
5	6.82 W/cm <sup>2</sup>	30	26	Cuticle (+)
6	8.27 W/cm <sup>2</sup>	30	30	

Note: "-" indicates no abnormalities or slight edema of shallow hypodermis. Cuticle "+" indicates changes of some cuticular cells (network changes of prickle cells) and liquification of basal cells.

The data in Table 6 were analyzed by a weighted linear regression method and the results are:

Regression equation:  $y = -2.380 + 10.352 x$   
 MRD<sub>50</sub>: 5.179 W/cm<sup>2</sup>  
 95 percent confidence level: 4.917 - 5.455 W/cm<sup>2</sup>  
 x<sup>2</sup> test: P < 0.05, acceptable

## 2. Human skin injury threshold

Each volunteer was exposed to a dosage level close to his MRD<sub>50</sub> to generate erythema that lasted 5 minutes skin samples were then taken for examination. Three volunteers with dark complexions were exposed to 4.933 W/cm<sup>2</sup>. Two showed no obvious pathological changes and one showed cuticular cell edema, some basal cell liquification, and hypodermal capillary dilation and congestion. Seven volunteers with an average complexion were exposed to 5.804 W/cm<sup>2</sup>. Six showed no changes, one showed slight pathological changes within the cuticular layer. Two volunteers with lighter complexions were exposed to 6.674 W/cm<sup>2</sup> and showed no pathological changes. The results are shown in Table 7.

Weighted linear regression of the data yielded:

Regression equation:  $y = -7.388 + 16.550 x$   
 MRD<sub>50</sub>: 5.603 W/cm<sup>2</sup>  
 95 percent confidence level: 5.490 - 5.719 W/cm<sup>2</sup>  
 x<sup>2</sup> test: P < 0.05, acceptable

Table 7. Human Skin Injury Caused by 488 nm Argon Ion Laser

<u>Group</u>	<u>Power density</u>	<u>No of shots</u>	<u>No of erythema</u>	<u>Pathological changes</u>
1	3.337 W/cm <sup>2</sup>	60	0	
2	3.918 W/cm <sup>2</sup>	60	2	
3	4.933 W/cm <sup>2</sup>	60	10	Three with darker complexion two (-), one (+)
4	5.369 W/cm <sup>2</sup>	60	18	
5	5.804 W/cm <sup>2</sup>	60	36	Seven with ave. complexion six (-), one (+)
6	6.239 W/cm <sup>2</sup>	60	48	
7	6.674 W/cm <sup>2</sup>	60	53	Two with lighter complexion both (-)
8	6.96 W/cm <sup>2</sup>	60	57	
9	7.25 W/cm <sup>2</sup>	60	60	

9698/6091

CSO: 8111/1099

## INJURY THRESHOLD OF RETINA IRRADIATED BY ARGON LASER LIGHT

Shanghai ZHONGGUO JIGUANG [CHINESE JOURNAL OF LASERS] in Chinese Vol 12, No 10, 20 Oct 85 pp 600-602

[Article by Wang Kangsun [3769 1660 1327], Wang Ling [3769 3781], Zhang Mingheng [1728 2494 3801], Shi Xianghe [2457 7449 5440], and Chen Gangqiang [7115 0474 1730] of the Department of Ophthalmology, Ruijin Hospital, Shanghai No 2 Medical University, and Hu Qingsheng [5170 1987 3088], Zhuo Ruipeng [0587 3843 7720], Jiang Lanying [3068 5695 5391], and Wu Jianu [0702 1367 1166] of the Laser Research Laboratory, Shanghai No 2 Medical University]

[Text] Abstract: The material, method, results and discussion of the research on the injury threshold of the retina of rabbits, monkeys, and human beings irradiated by argon laser light are introduced. When exposure time is 0.1 s, the retinal injury threshold (ED<sub>50</sub>) is 0.506 W/cm<sup>2</sup> for rabbits, 0.834 W/cm<sup>2</sup> for monkeys, and 1.757 W/cm<sup>2</sup> for human beings. When exposure time is 1 s, the retinal injury threshold is 0.428 W/cm<sup>2</sup> for rabbits.

Argon lasers are frequently used for medical purposes because their wavelengths--4880 Å and 5145 Å--correspond to a high absorption coefficient by the pigment in the retina and the choroid and by the hemoglobin. Since the argon laser has a unique focusing ability, it is particularly harmful to the eyes. In order to reduce and avoid eye injuries, a safety standard for the argon laser light is much needed. Here we report the retinal injury threshold of rabbits, rhesus monkeys, and humans.

### I. Experimental Setup

The light source used in the experiment was a 4880 Å argon ion laser. The setup consisted of the laser, the optical system, and the work bench, as shown in Figure 1. The output power of the laser was 1.2 W, the mode was close to a single mode, the divergence angle was 1.4 mrad, the power was stable to within 2 percent and the energy output was stable to within 3 percent. Irradiation times were 0.1 sec and 1 sec with an error of 0.004 sec. The spot size at the cornea was 2.76 mm. The optical system consisted of a time monitor, an energy monitor, an aiming system and an observation system.

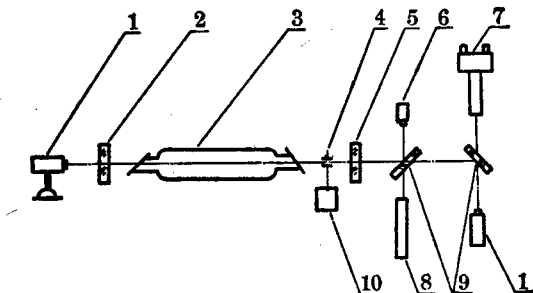

Figure 1. Optical system used in the experiment

- 1--Laser energy meter; 2--Total reflection mirror of cavity;  
 3--Argon ion laser tube; 4--Electronic shutter; 5--Half reflecting  
 mirror of cavity; 6--Time monitor probe; 7--Intraocular camera;  
 8--He-Ne laser; 9--Beam splitter; 10--Timer control

**Time monitor:** To facilitate the experiment and the monitoring, two 45° coated beam splitters were placed in the optical path to steer the laser beam. The irradiation time was controlled by a high-precision electronic shutter installed in the cavity. The time was controlled to 0.01 sec.

**Energy monitor:** A model NJ-1 laser energy meter was used to measure and monitor the energy. Extensive tests were made before the animal experiments and the calibrated energy differed very little from the actual value. The energy stability was better than 3 percent.

**Aiming and observation:** The irradiation was controlled by the shutter. A He-Ne laser was used at the aiming beam. By using a beam splitter, the red He-Ne beam was made to coincide with the blue 4880 Å argon laser beam for accurate aiming. The laser light was directed to the bottom of the eye. On the other side of the beam splitter, a Nikon intraocular camera was installed for real time observation and for photography.

## II. Experimental Results

The damage assessments were based on pigment spots on the retina or small light gray coagulation points that appeared within 1 hour after irradiation.

### 1. Intraocular camera indications

Damages near the threshold consisted of minute pigment isolation or light gray small coagulation spots, sometimes the size of a pinhead. No hemorrhage or bubbles were observed and damage indications often appear a few minutes after the laser shot. As the laser energy was increased, the coagulation spots became bigger, the color became lighter, and the boundary became clearer. No retina hemorrhage observed even for laser energies near the ED<sub>100</sub> level.

## 2. Optical microscope indications

(1) The retina of rabbits was irradiated with 5.6-6.0 mJ for 0.1 seconds and samples taken 30 minutes after irradiation. Optical microscopy showed that the fibrous layer of the retina had expanded, the number of dendrites decreased, and the core layer became cystic. The retina blood cells showed noticeable dilation but no hemorrhage.

(2) The retina was irradiated with 4.1-4.5 mJ for 0.1 second and the specimens were taken 24 hours after the irradiation. Optical microscopic observation revealed one surface bulge on the retina with local cell inflammation and exudation of spherical hemachromatin. The fibrous layer showed no noticeable injury but the chorioidea vessels were congested.

(3) Samples taken 48 hours after 0.1 sec irradiation at 4.4-4.9 mJ were examined. No abnormalities were observed except some congestion of the chorioidea blood vessels.

## 3. Electron microscope indications

Rabbit retinal specimens taken 30 minutes after irradiation at 5.6-6.0 mJ for 0.1 second were examined under an electron microscope. Some blister-like structures filled with medium electron density material were observed on the pigment epithelium, as shown in Figure 2. Cells showed myelin sheath-like structure and the chordriosome was damaged. The plate-like structure of the outer sector of visual cells had local cavities. The membrane had dissolved and high electron density material appeared between membrane structures, as shown in Figure 3. The inner section showed extensive chordriosome swelling, crest breakage, and local cavities (see Figure 4). The cytoplasm was not dissolved but the nuclear membrane showed shrinkage (see Figure 5).



Figure 2

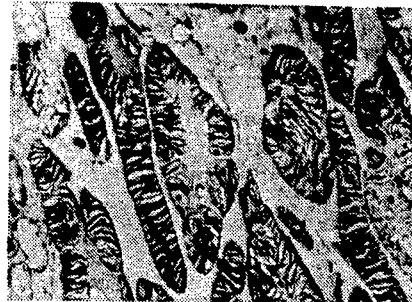

Figure 3

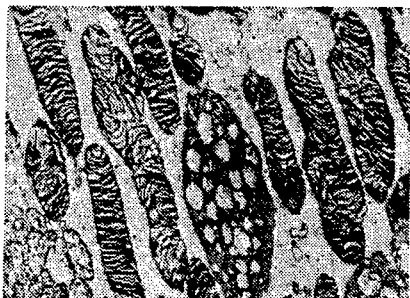

Figure 4

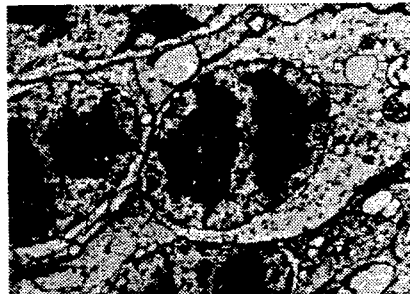

Figure 5

4. Statistics of experimental results (see Tables 1-4)

Table 1. Injury Threshold of Rabbit Retina by 0.1 Sec Exposure to Argon Laser

<u>Group</u>	<u>Average energy (mJ)</u>	<u>Average power density (W/cm<sup>2</sup>)</u>	<u>No of shots</u>	<u>No of positive reactions</u>	<u>Percent of positive reaction</u>
1	1.40	0.234	20	0	0
2	1.80	0.301	86	15	17.44
3	2.39	0.399	68	28	41.18
4	3.06	0.512	21	9	42.86
5	4.00	0.669	36	22	61.11
6	4.50	0.752	42	30	71.43
7	5.53	0.925	23	21	91.30

ED<sub>50</sub> energy = 3.03 mJ (front of cornea), 95 percent confidence limit = 2.74-3.34 mJ; ED<sub>50</sub> power density = 0.506 W/cm<sup>2</sup> (front of cornea), 95 percent confidence limit = 0.458-0.558 W/cm<sup>2</sup>.

Table 2. Injury Threshold of Monkey Retina by 0.1 Sec Exposure to Argon Laser

<u>Group</u>	<u>Average energy (mJ)</u>	<u>Average power density (W/cm<sup>2</sup>)</u>	<u>No of shots</u>	<u>No of positive reactions</u>	<u>Percent of positive reaction</u>
1	3.55	0.593	20	3	15.00
2	3.85	0.643	40	8	20.00
3	4.25	0.710	20	5	25.00
4	4.55	0.760	39	13	33.33
5	5.05	0.844	24	11	45.83
6	5.55	0.928	10	8	80.00
7	6.90	1.153	10	9	90.00

ED<sub>50</sub> energy = 4.985 mJ (front of cornea), 95 percent confidence limit = 4.533-5.482 mJ; ED<sub>50</sub> power density = 0.834 W/cm<sup>2</sup> (front of cornea), 95 percent confidence limit = 0.757-0.916 W/cm<sup>2</sup>.

Table 3. Injury Threshold of Human Retina by 0.1 Sec Exposure to Argon Laser

<u>Group</u>	<u>Average energy (mJ)</u>	<u>Average power density (W/cm<sup>2</sup>)</u>	<u>No of shots</u>	<u>No of positive reactions</u>	<u>Percent of positive reaction</u>
1	6.4	1.07	6	0	0
2	8.27	1.382	16	3	18.75
3	10.13	1.694	13	5	38.46
4	12.15	2.031	15	10	66.67
5	13.73	2.295	12	10	83.33

ED<sub>50</sub> energy = 10.51 mJ (front of cornea), 95 percent confidence limit = 9.43-11.71 mJ; ED<sub>50</sub> density = 1.757 W/cm<sup>2</sup> (front of cornea), 95 percent confidence limit = 1.576-1.958 W/cm<sup>2</sup>.

Table 4. Injury Threshold of Rabbit Retina by 1 Sec Exposure to Argon Laser

<u>Group</u>	<u>Average energy (mJ)</u>	<u>Average power density (W/cm<sup>2</sup>)</u>	<u>No of shots</u>	<u>No of positive reactions</u>	<u>Percent of positive reaction</u>
1	18.72	0.313	16	2	12.50
2	21.36	0.357	28	5	17.86
3	23.28	0.389	42	18	42.85
4	26.40	0.441	17	9	52.94
5	28.56	0.477	53	31	58.49
6	30.72	0.513	20	14	70.00
7	32.88	0.549	20	18	90.00

ED<sub>50</sub> energy = 25.64 mJ, 95 percent confidence limit = 24.14-27.23 mJ; ED<sub>50</sub> power density = 0.428 W/cm<sup>2</sup>, 95 percent confidence limit = 0.403-0.455 W/cm<sup>2</sup>.

From the 0.1 sec exposure experiments, the ED<sub>50</sub> power density is 0.506 W/cm<sup>2</sup> for the rabbit retina, 0.834 W/cm<sup>2</sup> for the monkey retina, and 1.757 W/cm<sup>2</sup> for the human retina. The ratios are rabbit:monkey:human = 1:1.65:3.47. Bringruber<sup>1</sup> has measured the injury threshold of monkey and rabbit retinae by 1 sec exposure of ruby laser and found that the threshold of the monkey retina was 50 percent higher than that of the rabbit retina.

#### REFERENCES

1. B. Bringruber, Health Physics, 44, 519 (1983).

9698/6091

CSO: 8111/1099

EXPERIMENTAL STUDY ON INJURY THRESHOLD OF ANIMAL RETINAS BY 488 nm LASER IRRADIATION

Shanghai ZHONGGUO JIGUANG [CHINESE JOURNAL OF LASERS] in Chinese Vol 12, No 10, 20 Oct 85 pp 603-605

[Article by Zhao Tongzhen [6392 2717 4176], Dang Zhiping [7825 3112 1627], An Xiaoyue [1344 2556 1471], Zhang Xiaoru [1728 1321 0320], and Guo Wenqi [6753 2429 3823] of the First Affiliated Hospital, Xi'an Medical University]

[Text] Abstract: The experimental results on retinal injury of animals arising from the 488 nm laser irradiation are reported. The ED<sub>50</sub> of the retinal injury in rabbits and monkeys were obtained for a parallel laser beam and for a beam passing through a convergent lens. The spot diameter at the cornea and the retina was also measured for the two illumination conditions.

#### I. Experimental Conditions

Light source: Model 360 argon ion laser, continuous wave output, TEM<sub>00</sub>-TEM<sub>01</sub> mode, maximum power output of 6 W, 0.5 mrad divergence, stability better than 4 percent.

Optical path: The laser light was expanded into a 6 mm diameter parallel beam by an inverted telescopic system. An electromagnetic shutter controlled the exposure time. The beam then passed through a 3 mm diameter diaphragm and a compensating concave lens. The light spot was positioned on the rabbit eye with the rabbit held on a platform with five degrees of freedom.

#### Monitor system:

1. The output power stability and the drift of the light spot entering the 3 mm diaphragm were monitored with a model GG-3 high-speed power meter and a model Rj 7200 energy meter respectively.
2. The exposure time was controlled by a model SDK-4 timer control. The actual time when the shutter was open was recorded by a model QD-1 digital timer. The error in time control was less than 0.001 percent.

Measurement equipment:

The measurement errors of the model LW-1 power meter and the model SD2490 high-speed digital power meter were less than  $\pm 2$  percent.

A microscope eyepiece reticule was used to obtain the light spot diameters on the cornea and on the retina. They were respectively  $833 \mu\text{m}$  and  $62 \mu\text{m}$ . The spot diameter on the retina when the 3 mm diameter parallel beam was incident on the cornea was  $900 \mu\text{m}$ . The ambient temperature was  $17\text{--}22^\circ\text{C}$  and the relative humidity was 75-80 percent.

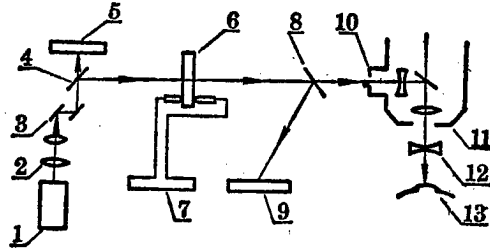

Figure 1. Optical path for retina irradiation by 488 nm argon ion laser

- 1--Argon ion laser; 2--Inverted telescope as beam expander;
- 3--Light guide arm; 4--Beam splitter; 5--Power monitor;
- 6--Electromagnetic shutter; 7--Time monitor; 8--Beam splitter;
- 9--Energy meter; 10--3 mm beam defining diaphragm; 11--Slit lamp;
- 12--Compensating concave lens; 13--Eyeball

II. Experiment

1. Grouping of the dosage level: Based on test-run results (Table 1), the dosage was divided into seven groups in the ratio of a geometric series (Table 2).

Table 1. Test-Run Results

Dosage ( $\text{W}/\text{cm}^2$ )	Exposure time (s)	
	1	0.145
Max. dosage	6.54	11.28
Min. dosage	3.77	4.16
Measurement device	LW-1 power meter and SD2490 power meter	

Table 2

Dosage (W/cm <sup>2</sup> )	Exposure time (s)	
	1	0.145
1	6.54	11.28
2	5.967	9.56
3	5.444	8.09
4	4.967	6.85
5	4.532	5.90
6	4.143	4.92
7	3.77	4.16

2. Selection and grouping of animals: Gray rabbits weighing 2 kg or so were selected. Animals with large pigment discrepancies were rejected. A total of 56 rabbits were used and 718 laser shots were made, 231 injury spots were examined and 3590 data points were collected.

In addition 11 rhesus monkeys weighing 4-5 kg were also used. Due to the small number of monkeys, they were not grouped. The monkey retinas were irradiated using the rabbit eye ED50 dosage and the reactions were examined visually and with microscope. The results are shown in Table 3.

Table 3

<u>Rabbit group</u>	<u>1(s)</u>	<u>0.145(s)</u>
No. of group	7	7
No. of rabbits/group	7	4
Sampling points/eye	6	7-8
Total sampling points	248	470

3. Experimental method: After pupil dilation and anaesthesia, the animal was held on a five-degree-of-freedom platform. The slit lamp was held fixed and the platform adjusted so that the laser beam was perpendicular to the cornea. Two horizontal rows of shots were made at 1/4 to 1 visual disk diameters below the visual disk (in the case of the monkeys; between the papilla and the yellow spot). There were three shots in each row with a spacing equal to two spot diameters. For the convenience of observation and locating the injury spots in the low dosage groups, one shot was made at a higher dosage to produce a level II reaction spot as a marker.

4. Observation and recording: Immediate reactions were assessed right after the exposure. The criterion for a positive reaction was a barely discernible injury spot observed in an ophthalmoscope 1 hour after the exposure. The size of the injury spot was far smaller than the smallest level I reaction spot in clinical laser coagulation. The diameter was less than 1 radian and the spot appeared as a light gray circle.

### III. Experimental Results

The experimental results on the rabbits and the monkeys are shown in Tables 4-7.

Table 4. Reaction of Rabbit Retina 1 Hour After a 1 Sec Exposure of 488 nm Argon Ion Laser (with compensating lens)

<u>Group</u>	<u>Dosage (W/cm<sup>2</sup>)</u>	<u>No of shots</u>	<u>Reaction spots</u>	<u>Reaction rate (%)</u>
1	6.54	48	48	100
2	5.967	48	41	85
3	5.444	48	33	69
4	4.967	48	26	54
5	4.532	48	17	35
6	4.134	48	9	19
7	3.77	48	0	0

Table 5. Reaction of Rabbit Retina 1 Hour After a 0.145 Sec Exposure of 488 nm Argon Ion Laser (with compensating lens)

<u>Group</u>	<u>Dosage (W/cm<sup>2</sup>)</u>	<u>No of shots</u>	<u>Reaction spots</u>	<u>Reaction rate (%)</u>
1	11.28	64	64	100
2	9.56	64	53	82.81
3	8.09	64	44	68.75
4	6.85	56	31	55.35
5	5.80	64	23	35.94
6	4.92	64	16	25.00
7	4.16	64	0	0

Table 6. Reaction of Monkey Retina 1 Hour After a 0.145 Sec Exposure to 488 nm Argon Ion Laser (with compensating lens)

<u>Group</u>	<u>Dosage (W/cm<sup>2</sup>)</u>	<u>No of shots</u>	<u>Reaction spots</u>
1	6.54x0.5	12	0
2	6.54x1	12	2
3	6.54x1.5	18	3
4	6.54x2	10	5

Table 7. Reaction of Monkey Retina 1 Hour After a 0.145 Sec Exposure to a Parallel Beam of 488 nm Argon Ion Laser

<u>Group</u>	<u>Dosage (W/cm<sup>2</sup>)</u>	<u>No of shots</u>	<u>Reaction spots</u>	<u>Reaction rate (%)</u>
1	6.54x2	20	4	20
2	6.54x3.5	20	9	45
3	6.54x4	20	11	55
4	6.54x5	13	9	69
5	6.54x5.5	12	10	83
6	6.54x5.8	11	11	100

Note: 6.54 W/cm<sup>2</sup> is the ED<sub>50</sub> value for rabbits.

Using the same procedure, 50 shots were also made on human retinas at multiples of the rabbit ED<sub>50</sub> dosage. The dosage for a 50 percent reaction rate was about 2.7 times the rabbit ED<sub>50</sub> dosage. The overall results showed a positive correlation between the injury rate and the irradiation dosage. For a fixed laser wavelength, a high dosage was required to produce the same injury when the exposure time was shortened.

#### IV. Data Processing

The data were processed using a weighted regression method. The ED<sub>50</sub> results of corneas are shown in Table 8 and the ED<sub>50</sub> results are shown in Table 9.

Table 8

<u>Expt. subject</u>	<u>Exposure time (sec)</u>	<u>Mode of exposure</u>	<u>Spot diameter (mm)</u>	<u>ED<sub>50</sub> (W/cm<sup>2</sup>)</u>
Rabbit	1	With compensating lens	0.833	4.827
		Parallel light	3	0.396
	0.145	With compensating lens	0.833	6.54
		Parallel light	3	0.504
Monkey	0.145	With compensating lens	0.833	13.08
		Parallel light	3	1.8
Human	0.145	With compensating lens	0.833	17.65

Table 9

<u>Expt. subject</u>	<u>Exposure time (sec)</u>	<u>Mode of exposure</u>	<u>Spot diameter (mm)</u>	<u>ED<sub>50</sub> (W/cm<sup>2</sup>)</u>
Rabbit	1	With compensating lens	0.062	510.09
	0.145	With compensating lens	0.062	629.27
	0.145	Parallel light	0.9	3.08

Note: Corrections were made for compensating lens and eye medium losses.

## V. Histological Examination

Two rabbit eyes were irradiated in the same manner using the computed ED50 dosage. For the 0.145 sec exposure time, two dosage increments were used above and below the threshold, one eyeball was exposed to each dosage with a total of six eyeballs. Samples were taken 1 hour after the exposure. HE staining observations were made on 30-90 sections of paraffin imbedded samples, the results are published elsewhere.

Participants of the experiments were: Zhang Dexiu [1728 1795 4423], Geng Lide [5105 4539 1795], Ai Hong [5337 4767], Li Yujun [2621 3768 0193], Jiang Beisheng [1203 0554 3932], Wu Tingbi [0702 1694 1084], Yan Wenhui [1693 2429 1920], Zhang Hong [1728 4767], and Ma Shuxian [7456 3219 1288].

9698/6091

CSO: 8111/1099

## RESEARCH ON INJURY THRESHOLD OF RABBIT CORNEA BY CO<sub>2</sub> LASER

Shanghai ZHONGGUO JIGUANG [CHINESE JOURNAL OF LASERS] in Chinese Vol 12, No 10, 20 Oct 85 pp 606-608, 605

[Article by Wang Kangsun [3769 1660 1327], Wang Ling [3769 3781], Zhang Mingheng [1728 2494 3801], Shi Xianghe [2457 7449 5440], Chen Gangqiang [7115 0474 1730], and Shi Haiyun [4258 3189 0061] of the Department of Ophthalmology, Ruijin Hospital, Shanghai No 2 Medical University, and Zhuo Ruipeng [0587 3843 7720], Hu Qingsheng [5170 1987 3088], Jiang Lanying [3068 5695 5391], Wang Yuejin [3769 6460 6651], and Gai Baokang [5556 1405 1660] of the Laser Research Laboratory, Shanghai No 2 Medical University]

[Text] Abstract: The material, methods, and results of research on the injury threshold of rabbit cornea caused by CW CO<sub>2</sub> laser light are introduced. The dose for causing ED<sub>50</sub> varies with the time of exposure: they are 3.62 W/cm<sup>2</sup> and 4.01 W/cm<sup>2</sup> for 1 sec and 125 ms irradiation respectively.

CO<sub>2</sub> lasers are finding broad clinical applications as well as laboratory and industrial uses. Since its wavelength 10.6 μm falls in the invisible far infrared regime, it may cause injuries if not used carefully. The eye injury by the CO<sub>2</sub> laser light occurs primarily in the cornea and not in the interior of the eyeball. In this paper we report an injury threshold study of the rabbit cornea by CO<sub>2</sub> laser. It is intended to provide some basis for establishing China's laser safety standard.

### I. Experimental Setup

The CO<sub>2</sub> laser used in the experiment had an output power of 20 W, a divergence angle of less than 3 mrad, and the beam mode was close to the fundamental. The fluctuation of the output power was controlled to within 3 percent. In order to maintain a stable power output, the thermal equilibrium of the cavity was carefully guarded. The beam was first focused with a germanium lens (f/35 mm), and was then diverged. The power density at the target tissue was varied by adjusting the outer sleeve of the lens tube and by attaching extensions of different length. The spot diameter on the cornea was 1 mm and the exposure was made through a thin stainless tube, as shown in Figure 1.

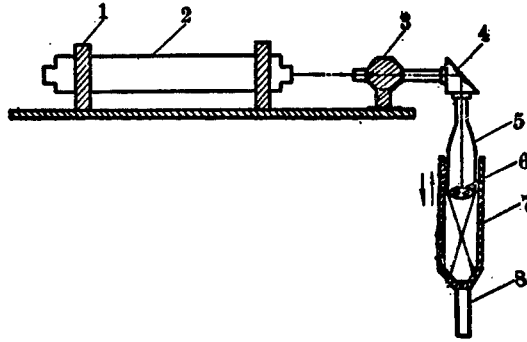

Figure 1. Optical transmission system

1--Hold-down ring for laser tube; 2--CO<sub>2</sub> laser tube; 3--Holder for light transmission system; 4--Light guide arm (one section); 5--Germanium lens tube (inner tube); 6--f/35 germanium lens; 7--Movable outer sleeve; 8--Variable length extension (set of five)

## II. Experimental Method

The experimental animals were 2-3 kg gray rabbits with similar eye color. Animals with cornea disease such as cloudiness, white spots, and cornea epithelium detachment were rejected. The rabbits were anesthetized with 2.5 percent isobarbituric sodium 25 mg/kg intravenous solution without dilating the pupils. The 10.6  $\mu\text{m}$  CW CO<sub>2</sub> laser light was directed onto the cornea perpendicularly through the 1 mm diameter extension with the cornea 5 mm from the exit of the extension tube. The laser beam irradiated the cornea in the pupil region at five points: the center of the pupil and four peripheral points in the 1:30, 4:30, 7:30, and 10:30 directions. The spacing between two shots was at least two spot diameters (see Figure 2). One group was exposed for 1 second and the other group exposed for 125 ms. Each group of rabbits was further divided into 6-7 dosage levels. A minimum of 30 eyeballs were exposed at each dosage level and a total of 402 eyeballs of 202 rabbits [sic] were irradiated. A 10-minute observation period followed the laser shots and small white spots on the cornea found in this period were considered a positive reaction. The observations were conducted by two experimental ophthalmologists.

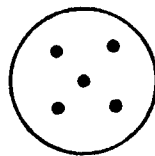

Figure 2. Irradiation positions on the cornea by CO<sub>2</sub> laser

### III. Experimental Results

#### 1. Cornea examination

For the 1 second exposure group the cornea showed larger spots, 0.1-0.3 mm in diameter, light gray in color, usually circular in shape, and very few strip-like or crescent in shape. This may depend on whether the laser beam is perpendicular to the cornea. All spots disappeared within 24-48 hours.

The 125 ms exposure group showed much smaller spots on the cornea, all of them the size of a pinhead, white in color and disappeared within 24 hours.

#### 2. SEM examination

(1) The corneas of gray rabbits were irradiated at an energy level close to the ED<sub>50</sub> dosage (32 mW) for a second and specimens were taken 30 minutes after the shots. SEM examination showed rupture of the epithelium cells and a reduction of the number of microfibril on the nucleus (as shown in Figure 3). The epithelium cells recovered after 48 hours, as shown in Figure 4.

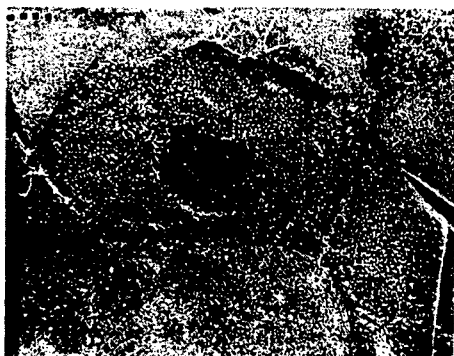

Figure 3. 2100 X magnification

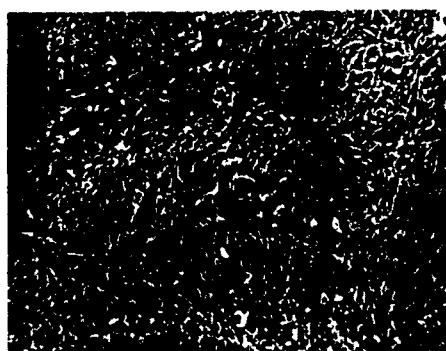

Figure 4. 5620 X magnification

(2) The gray rabbit corneas were also irradiated at a dosage level exceeding the ED<sub>100</sub> dose (60 mW) for 1 second and specimens were taken 30 minutes after the shots. SEM examination showed a decrease of microfibril of some epithelium cells and necrosis of nucleus (see Figure 5). Some cell membrane detachments were observed, showing the underlying microfibril (Figure 6). After 48 hours, some epithelium cells still showed sparse microfibril and the cells showed lattice-like changes (Figure 7).

#### 3. Statistical analysis of data

The results of the six groups exposed for 1 sec and the seven groups exposed for 125 ms are listed in Tables 1 and 2. Both sets of data were analyzed with a weighted linear regression method to find ED<sub>50</sub>. The results are:

1 second exposure groups:

$$ED_{50} = 3.62 \text{ W/cm}^2$$

$$95 \text{ percent confidence limit} = 3.56\text{--}3.68 \text{ W/cm}^2$$

125 ms exposure groups:

$$ED_{50} = 4.01 \text{ W/cm}^2$$

$$95 \text{ percent confidence limit} = 3.97\text{--}4.03 \text{ W/cm}^2$$



Figure 5. 1060 X magnification



Figure 6. 2100 X magnification



Figure 7. 1060 X magnification

Table 1. 1 Sec Exposure Results

Group	Ave. energy (mJ)	Ave. power density (W/cm <sup>2</sup> )	No of shots	No of reactions	Positive reaction rate (%)
1	21.61	2.75	150	4	2.67
2	23.16	2.95	155	14	9.03
3	27.24	3.47	150	68	45.33
4	30.35	3.86	150	90	60.00
5	34.60	4.40	155	136	87.74
6	37.01	4.71	150	148	98.67

Table 2. 125 ms Exposure Results

Group	Ave. energy (mJ)	Ave. power density (W/cm <sup>2</sup> )	No of shots	No of reactions	Positive reaction rate (%)
1	3.13	3.19	160	1	0.62
2	3.40	3.47	340	11	3.24
3	3.67	3.74	155	50	32.26
4	3.98	4.05	155	92	59.35
5	4.26	4.34	155	112	72.26
6	4.55	4.63	150	139	92.67
7	4.83	4.92	150	148	98.67

#### IV. Discussion

Judging from our experimental results, cornea injuries occurred in 1 sec exposures at 3.62 W/cm<sup>2</sup> and 125 ms exposures at 4.01 W/cm<sup>2</sup>. Of course the injuries near the threshold were light and reversible, and limited to the epithelium of the cornea. Slit lamp cornea microscope and SEM observations showed that the injuries were repaired within 24-48 hours without remnants. The absorption of the visible light depended on the amount of pigment whereas the absorption of the far infrared laser light depended on the water content; most of the far infrared energy was absorbed by the water. The water content of the cornea is greater than 75 percent. The absorption curve of the cornea is greater than 75 percent. The absorption curve of the cornea is similar to that of water,<sup>1</sup> the majority of the energy of the CO<sub>2</sub> laser is therefore absorbed by the water-rich cornea tissue and the generated heat produces the damage. An increased power or exposure time leads to an increase of the cornea temperature and results in thermal injury and protein coagulation.<sup>1</sup> The injuries at doses above the threshold are much more complex. Campbell found that an exposure to a CO<sub>2</sub> laser at 100 mW for 3 seconds caused shrinkage of the shallow layer of the cornea. At 500 mW the injury extended to the deep layer of the cornea, accompanied by the formation of new blood vessels. Such injuries may heal but the scarred tissue affected the transparency of the cornea. At a dose above 1000 mW, cornea puncture and crystal injury may occur.<sup>2</sup>

As CO<sub>2</sub> lasers find increasingly wide uses in laboratories, hospitals, and in industries, and the power levels are generally higher (at least several tens of watts), cornea injuries may be caused by CO<sub>2</sub> laser beams reflected from tools, surgical instruments and mirrors. The results are of course disastrous if one inadvertently looks directly into the beam. Since infrared lights are invisible, the danger is higher.

#### REFERENCES

1. H.M. Leibowitz, et al., ARCH. OPHTHALMOL., 1969, 81, 713.
2. C.J. Campbell, et al., AM. J. OPHTHALMOL., 1968, 66, 604.

9698/6091  
CSO: 8111/1099

RESEARCH ON INJURY THRESHOLD OF GRAY RABBIT'S RETINA BY Q-SWITCHED, FREQUENCY DOUBLED Nd<sup>3+</sup>:YAG LASER

Shanghai ZHONGGUO JIGUANG [CHINESE JOURNAL OF LASERS] in Chinese Vol 12, No 10, 20 Oct 85 pp 609-611

[Article by Wang Kangsun [3769 1660 1327], Wang Ling [3769 3781], Zhang Minheng [1728 2494 3801], Shi Xianghe [2457 7449 5440], Chen Gangqiang [7115 0474 1730], and Shi Haiyun [4258 3189 0061] of the Department of Ophthalmology, Ruijin Hospital, Shanghai No 2 Medical University, and Jiang Lanying [3068 5695 5391], Zhuo Ruipeng [0587 3843 7720], Hu Qingsheng [5170 1987 3088], and Wu Jianu [0702 1367 1166] of the Laser Research Laboratory, Shanghai No 2 Medical University]

[Text] Abstract: The material, methods, and results of the research on the injury threshold of gray rabbit's retina caused by Q-switched and frequency doubled Nd<sup>3+</sup>:YAG laser light are introduced. When exposure time is 8 ns, ED<sub>50</sub> is 232.05 μJ/cm<sup>2</sup> (precornea).

Frequency doubled Nd<sup>3+</sup>:YAG laser emits a green light of a wavelength 5300 Å. The wavelength corresponds to a high transmissivity in the vitreous humor and a high absorptivity by the retina and choroid. It is also near an absorption peak of the hemoglobin and can cause more injury to the eye than other wavelengths. This is especially true for large pulses. In this work we studied the retinal injury threshold of gray rabbits by the Nd<sup>3+</sup>:YAG laser and collected data for establishing a laser safety standard.

#### I. Experimental Setup

The laser used in our experiment was a Q-switched YAG pulse laser built by the Shanghai Jiaotong University. The maximum energy output was 20 mJ, the divergence angle was 4.5 mrad, the pulse width was 8 ns, the laser may be operated to produce a single pulse or be pulsed once every second, and the output was multimode.

The optical system consisted of a He-Ne laser, a beam splitter, a filter, an attenuation and an ophthalmoscopic camera, shown in Figure 1.

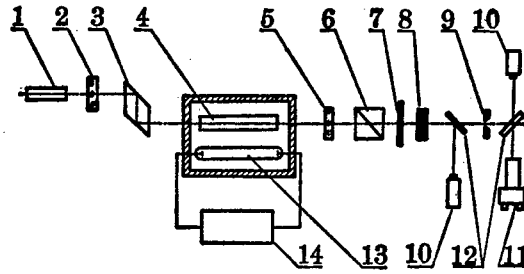

Figure 1. Q-switched frequency doubled YAG laser setup

1--He-Ne laser; 2--Total reflection mirror; 3--LN Q-switch crystal; 4--YAG rod; 5--Half-reflecting mirror; 6--KDP frequency doubling crystal; 7--Filter; 8--Attenuator; 9--Diaphragm; 10--Energy meter; 11--Ophthalmoscopic camera; 12--Beam splitter; 13--Pulsed xenon lamp; 14--Power supply

The He-Ne laser followed the same optical path as the 5300 Å green laser light and served as an alignment and aiming beam. The beam splitter with a ratio of 1:1 was used to measure the laser energy.

The filter eliminated the infrared component and the attenuator controlled the intensity of the 5300 Å output. Since the laser had a multimode output, the homogeneity of the spot was poor. A 2.5 mm diameter diaphragm was therefore placed in front of the eyeball to limit the spot size and shape and to improve the homogeneity. The beam diameter at the cornea was 4.0 mm. A Nikon ophthalmoscopic camera was used to observe and photograph the bottom of the eyeball. The laser passed through the cornea directly without any compensating lens or contact lens.

The pulse width of the Q-switched laser was very narrow. A Tektronics 466 storage oscilloscope with a sweep time of 20 ns/div was used to capture the optical signal. Real time monitoring was used to assure accuracy. The model RJP-700 laser light energy meter was equipped with two probes and the measured energies and their ratio were stored in the unit. The two probes were placed behind the two beam splitters for real time monitoring. Extensive tests showed that the error was less than 5 percent.

## II. Experimental Method

Gray rabbits weighing 2-3 kg without eye diseases were selected for the experiment. The animal was anesthetized and placed in the cage with multiple degrees of freedom. The He-Ne laser was aimed at the region below the papilla of the rabbit. The eye was first examined with the Nikon ophthalmoscopic camera and the Q-switched YAG laser was then used for the irradiation. Ten to 20 shots were made in each eyeball with a spacing equal to at least two spot diameters. A total of 691 shots were made on 64 eyeballs on 32 rabbits. Ophthalmoscopic photos were taken after the shots. Some eyeballs were removed for optical and electron microscope specimen preparation. The ambient temperature was 25-28°C and the humidity was 62-82 percent.

### III. Experimental Results

Two experimental ophthalmologists made the observations after the irradiation. A positive reaction was recorded if pigment spots, coagulation spots or hemorrhage were observed on the retina within 1 hour.

1. Ophthalmoscopic camera indications: Depending on the laser energy, the reaction of the rabbit retina to the Q-switched YAG laser irradiation may be divided into six cases: 1) Pigment spreading like soap bubbles; 2) small coagulation spots with small pigment spots at the center; 3) coagulation spot surrounded by pigment rings; 4) cauliflower-like hemorrhage pattern with central coagulation spot; 5) circular hemorrhage in the deep layer with central coagulation spot. The hemorrhage may occur with or without delay; and 6) extensive hemorrhage of the retina and flowing into the vitreous humor. For a dosage level up to ED<sub>100</sub>, the retina reactions were generally pigment spreading, small coagulation spots, and sometimes hemorrhage spots. The injuries were very minor and difficult to detect under an ophthalmoscope.

2. Optical microscope indications: The retina was irradiated with 330.41  $\mu\text{J}/\text{cm}^2$  (ED<sub>100</sub> dose) and the specimens were taken 30 minutes after the laser shot. Optical microscopic examinations failed to show any obvious injuries of the retina pigment epithelium or the visual cell layer. Slight congestion of the choroid blood vessels and hemorrhage were observed.

3. SEM indications: After an exposure at a dosage level of 330.41  $\mu\text{J}/\text{cm}^2$  (ED<sub>100</sub> dose), blisters were observed at local sites on the pigment epithelium and they were filled with a material of medium electron density. Medullary sinus-like structures appeared in the cells, the chondriosome swelled and the crest was broken (shown in Figure 2). The disk structures on the outer section of the optic cells showed local voids, the membrane structure dissolved and high electron density particulates showed up between the membrane structures, as shown in Figure 3. Extensive inner section chondriosome swelling, crest breaking, and cavitation (Figure 4) were observed. The cytoplasm of the outer particulate layer had dissolved and the nucleus showed no obvious changes (Figure 5).

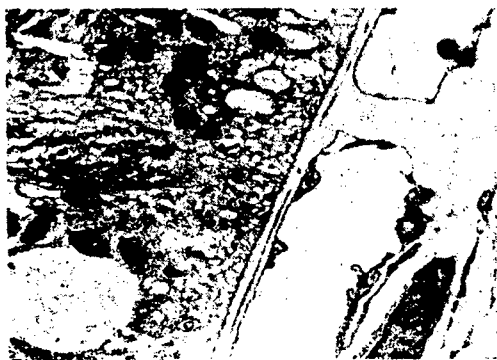

Figure 2. 9250 X magnification

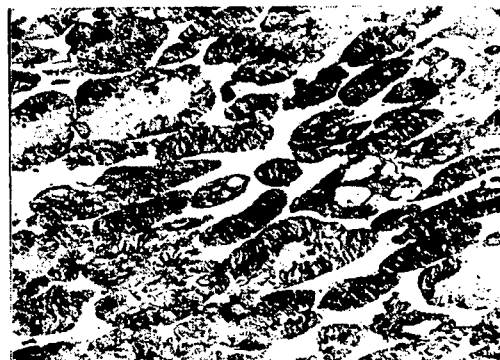

Figure 3. 5550 X magnification

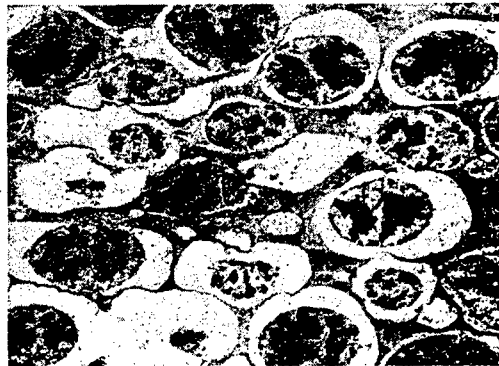

Figure 4. 7600 X magnification

Figure 5. 5700 X magnification

#### 4. Statistical analysis of data

A weighted linear regression method was used in analyzing the positive reaction of 691 laser shots on 64 pairs of rabbit eyeballs. The results are listed in Table 1.

Table 1. Retinal Reaction of Rabbits Irradiated by Q-Switched Frequency Doubled YAG Laser

Group	Average energy ( $\mu\text{J}$ )	Energy density ( $\mu\text{J}/\text{cm}^2$ )	No of shots	No of reactions	Positive reaction rate (%)
1	21.5	171.18	79	7	8.86
2	25.5	203.03	97	32	32.99
3	29.5	234.87	98	55	56.12
4	33.5	266.72	100	72	72.00
5	37.5	298.57	90	71	78.89
6	41.5	330.41	84	77	91.67

Note:  $\text{ED}_{50} = 232.05 \mu\text{J}/\text{cm}^2$  (before cornea)  
 95 percent confidence limit =  $224.87-239.45 \mu\text{J}/\text{cm}^2$

#### IV. Discussion

Since the Q-switched frequency doubled YAG laser has a wavelength of  $5300 \text{ \AA}$ , the absorption by the retina, choroid, and hemoglobin is high. Since the laser pulse is short (of the order of nanoseconds), retinal hemorrhage is likely. The energy causing hemorrhage is close to the threshold dosage. The  $\text{ED}_{50}$  energy is  $29.14 \mu\text{J}$ . At  $40 \mu\text{J}$ , about one-third of the reaction points showed hemorrhage. The study of the injury threshold of Q-switched YAG laser is therefore very important for laser safety standards.

In terms of the reaction at the back of the eye, optical and electron microscopic observations show that short duration large energy pulses at  $5300 \text{ \AA}$  have both a thermal effect and a shock wave effect on the retina

and the choroid. The thermal effect led to coagulation spots. SEM showed local blisters of the pigment epithelium filled with medium electron density material. The inner and outer sections of the optic cell had suffered various degrees of damage such as the dissolving of the disk structure, the swelling of the chondriosome, and the dissolving of the cytoplasm. The shock wave effect led to hemorrhage of the back of the eye. Optical microscope showed hemorrhage of the choroid but only slight congestion.

9698/6091

CSO: 8111/1099

## RETINAL INJURY THRESHOLD BY CW Nd<sup>3+</sup>:YAG LASER LIGHT

Shanghai ZHONGGUO JIGUANG [CHINESE JOURNAL OF LASERS] in Chinese Vol 12, No 10, 20 Oct 85 pp 612-614

[Article by Xu Jiemin [1776 4309 2404], Hu Fugen [5170 1381 2704], Zhou Shuying [0719 3219 5391], Cao Weiqun [2580 4850 5028], Xu Guidao [1776 6311 6670], Qian Huanwen [6929 3562 2429], Shi Liangshun [2457 5328 7311], and Wang Denglong [3769 6260 7893] of the Institute of Radiation Medicine, Academy of Military Medical Sciences]

[Text] Abstract: One hundred rabbit eyes were exposed to CW Nd<sup>3+</sup>:YAG laser light. Using ophthalmoscopic criteria for retinal injury, the intraocular injury points (ED<sub>50</sub>) were 2.52 W/cm<sup>2</sup> and 5.42 W/cm<sup>2</sup> for exposure time of 1.02 s and 0.12 s, respectively.

The purpose of this investigation is to study the injury threshold of the eye by CW Nd<sup>3+</sup>:YAG laser and to provide biological data for the establishment of a laser safety standard.

### I. Experimental Setup and Method

The experimental setup consisted of a model JQY-1 CW Nd<sup>3+</sup>:YAG laser, a time monitor, an electronic shutter, an He-Ne laser, and a beam defining jaw. The maximum output power of the laser was about 9.5 W. The beam divergence angle after a 3x collimating telescope and a 510 mm focal length lens were respectively 16 mrad and 3 mrad. The stability of the output power was better than  $\pm 5$  percent. The diameter of the beam defining jaw was 5 mm. The setup and the optical path are shown in Figures 1 and 2.

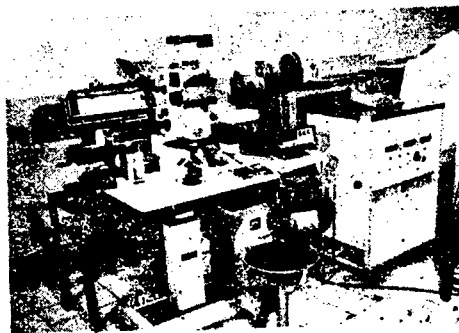

Figure 1. Irradiation setup using CW Nd<sup>3+</sup>:YAG laser

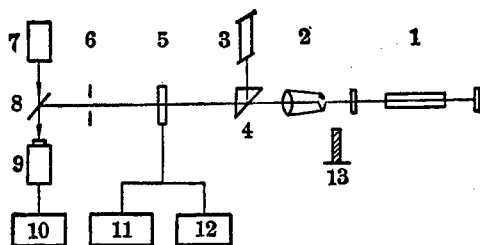

Figure 2. Optical path for CW Nd<sup>3+</sup>:YAG laser output power measurement

1--CW Nd<sup>3+</sup>:YAG laser; 2--Telescope; 3--He-Ne laser; 4--Right-angle prism; 5--Shutter; 6--Diaphragm; 7--TOPCON ophthalmoscopic camera; 8--Reflecting mirror; 9--RKP-545 probe; 10--RK-5200 laser power rate meter; 11--Timer control; 12--Time monitor; 13--Shielding plate

The experimental animals were 2-3 kg gray rabbits. Examinations were made of the back of the eye before laser irradiation. The hyperopia was less than 2.25 D, the myopia was less than 1.00 D, and no corrections were made.

The irradiation was confined to the central visual zone of the back of the eye and 10 shots were made for each eye. Ophthalmoscopic observations were made 1 hour and 24 hours after irradiation and the observations were made by two people. Some of the rabbits were killed and the eyeballs removed for pathological and histological examinations.

## II. Experimental Results

The dosage range was 2.02-9.09 W/cm<sup>2</sup> for cornea incidence. The average irradiation times were 1.02 sec and 0.12 sec, with five dosage levels for each irradiation time. A total of 1000 shots was made on 100 rabbit eyes.

### 1. Retinal injuries

For the dosage used in this study, the retinal injuries were light. Ophthalmoscopic examinations made 1 hour after the shots showed small circular or elliptical light gray spots with sparse dark pigment particles at the center and the perimeter. Some spots were surrounded by a light gray edema ring. The more severe injuries showed a small black burn spot at the center. Some spots showed small hemorrhage at the center.

Observations made after 24 hours showed a spreading of the damage and a noticeable increase of black pigments at the perimeter. The edema receded after 3-5 days and the damage shrank toward their center after 5-10 days and became light gray pigment deposits.

The retinal injuries caused by the CW Nd<sup>3+</sup>:YAG laser are shown in Figure 3.



Figure 3. Light gray injury spots of the rabbit retina caused by 0.1 sec irradiation of CW Nd<sup>3+</sup>:YAG laser light at 5.09 W/cm<sup>2</sup>

## 2. Retinal injury rate as a function of dosage and time

Irradiation was conducted at 10 dosage levels. For the first five groups the average exposure time was 1.02 sec. For the second five groups the average exposure time was 0.12 sec. Table 1 lists the dosage, exposure time, and injury rate. As can be seen, the rate of retinal injury increased with the incident power density and the incident power density for a given injury decreased with an increase in exposure time. The injury occurrence rate was 11-92 percent for an exposure time of 1.02 sec and an average incident power density of 2.02-3.21 W/cm<sup>2</sup> at the cornea. The injury occurrence rate was 13-91 percent for an exposure time of 0.12 sec and an average incident power density of 3.56-9.09 W/cm<sup>2</sup> at the cornea.

Table 1. Irradiation Dosage, Exposure Time, and Retinal Injury Rate of Rabbit Eyes Irradiated by a CW Nd<sup>3+</sup>:YAG Laser

Group	Ave. exposure time (s)	Ave. incident dose		Injury rate	
		(W)	(W/cm <sup>2</sup> )	Injury/ No of shots	%
1	1.019	6.30x10 <sup>-1</sup>	3.21	92/100	92
2	1.022	5.62x10 <sup>-1</sup>	2.87	73/100	73
3	1.023	4.99x10 <sup>-1</sup>	2.55	53/100	53
4	1.019	4.50x10 <sup>-1</sup>	2.30	33/100	33
5	1.020	3.96x10 <sup>-1</sup>	2.02	11/100	11
6	0.116	1.78	9.09	91/100	91
7	0.117	1.27	6.47	67/100	67
8	0.118	9.98x10 <sup>-1</sup>	5.09	44/100	44
9	0.119	8.37x10 <sup>-1</sup>	4.27	28/100	28
10	0.118	6.97x10 <sup>-1</sup>	3.56	13/100	13

## 3. Calculation of the injury threshold of a CW Nd<sup>3+</sup>:YAG laser

The experimental data were analyzed using a Bliss probability unit, weight regression method to find the regression equation for the CW Nd<sup>3+</sup>:YAG laser. For the 1.02 sec exposure time, the regression equation was

$$\hat{Y} = 12.45X + 0.0065$$

where  $X$  is the logarithm of the dosage and  $\hat{Y}$  is the probability unit for rabbit retinal injury. Also computed was

$$ED_{50} \approx 2.52 \text{ W/cm}^2$$

(95 percent confidence limit = 2.46-2.58 W/cm<sup>2</sup>)

For the average exposure time of 0.12 sec, the regression equation was found to be

$$\hat{Y} = 5.950X + 0.6335$$

$$ED_{50} \approx 5.42 \text{ W/cm}^2$$

(95 percent confidence limit = 5.16-5.69 W/cm<sup>2</sup>)

The regression line was checked for  $X^2$ . The  $X^2$  values for the 1.02 sec and 0.12 sec exposure time groups were respectively 1.0401 and 0.1695, much less than the  $X^2_{0.05}$  value of 7.8045 in both cases ( $P > 0.05$ ). This showed that for both exposure conditions the linear relationship held. Figures 4(a) and (b) show the regression curves.

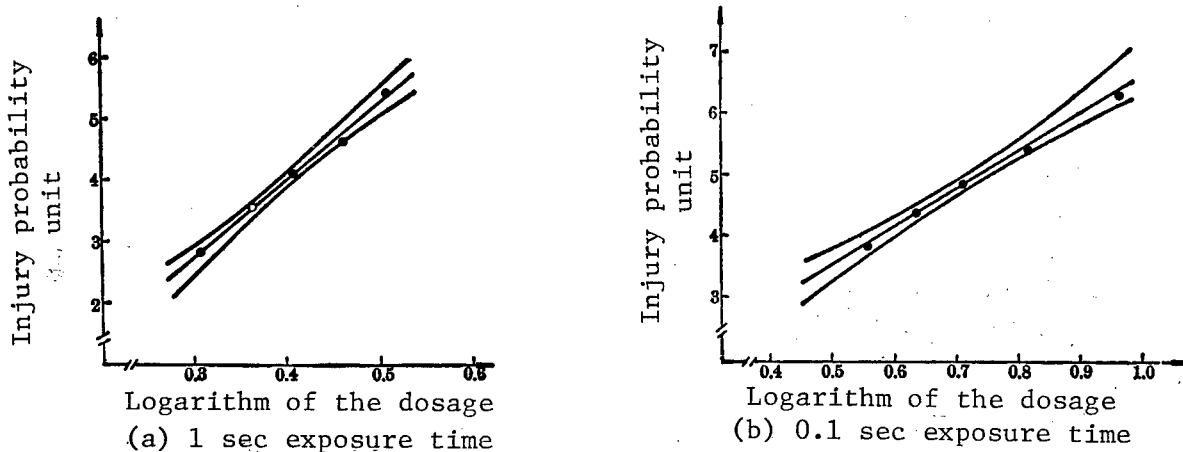

Figure 4. Regression lines of rabbit retinal injury by a CW YAG laser

#### 4. Pathological indications of retinal injury by CW YAG laser

Using dosage close to the injury threshold, irradiations were made at an average incidence power density of 2.55-3.21 W/cm<sup>2</sup> for 1.02 sec and at 5.09 W/cm<sup>2</sup> for 0.12 sec. The retinal injuries showed the following pathological changes:

Particle-like exudates and vaporized regions were present under the retina, causing a slight bulge in the retina. The vaporized regions were located between the liquid exudate and the particles and spread outward in a circular pattern. Detachment of dead cells was visible in the vaporized region.

Some pigment epithalium cells showed severe swelling and even rupture. Black pigment was dispersed or piled into pigment bands. Damaged optic cells showed broken outer sections. Typical damages were 200-300  $\mu\text{m}$  long (see Figure 5).



(a) Exudation and vaporization under the retina (exposed for 1 sec at  $2.55 \text{ W/cm}^2$ )

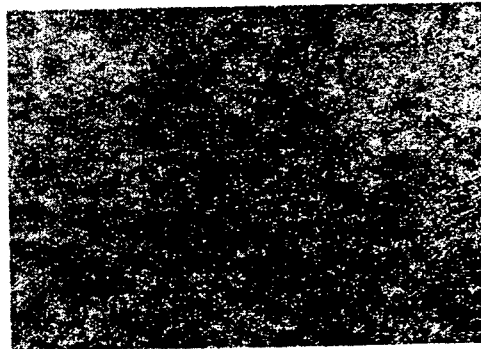

(b) Exudation under the retina, pigment segregation, and vaporized region ruptured the inner and outer granular layer (exposed for 1 sec at  $5.09 \text{ W/cm}^2$ )

Figure 5. Retinal injury caused by CW Nd:YAG laser (x63 magnification)

For dosage greater than the injury threshold shrinkage of the cell nucleus in the inner and outer granular layer, swelling or detachment of the ganglia nucleus were observed in the vaporized region.

### III. Conclusions

We made 1000 shots on 100 gray chinchilla rabbit eyes with a model JQY-1 CW Nd:YAG laser. The data were analyzed with a Bliss weighted regression method to find the retinal injury threshold for 1.02 sec and 0.12 sec exposure. The values of ED50 were respectively  $2.52 \text{ W/cm}^2$  and  $5.42 \text{ W/cm}^2$ . The injury indications and pathological changes were described.

The authors thank Tang Zhongming [3282 0112 2494] for computer analysis of the data.

9698/6091  
CSO: 8111/1099

## INJURY THRESHOLD OF HUMAN EYE BY PULSED YAG LASER BEAMS, PATHOLOGICAL OBSERVATION

Shanghai ZHONGGUO JIGUANG [CHINESE JOURNAL OF LASERS] in Chinese Vol 12, No 10, 20 Oct 85 pp 615-617

[Article by Chen Rongjia [7115 2837 1367], Chu Renyuan [5969 0088 6678], Li Mengchang [2621 5492 2490], Li Ling [2621 1515], Lu Jiahua [0712 0857 5478], and Fu Tiansheng [0265 1131 3932] of the Ophthalmic Research Institute of Shanghai Medical University and Cui Jixiu [1508 1323 4423], Zhu Baoqian [2612 1405 6870], and Lu Zhenzhen [0712 3791 3791] of the Shanghai Institute of Optics and Fine Mechanics, Chinese Academy of Sciences]

[Text] Abstract: The injury threshold of human retina by 150  $\mu$ s pulsed YAG laser beam irradiation is reported. Pathological phenomena of injured retina were observed directly using optical microscope and electron microscope.

Based on the animal test results, we have obtained some retinal injury data of the human eye by 150  $\mu$ s wide YAG laser pulses at a wavelength of 1.06  $\mu$ m. We also gained preliminary understanding of the retinal damage of human eyes by laser by comparing the pathology of retinal injuries in animals and in humans.

### I. Measurement of the Injury Threshold of Human Eyes

150  $\mu$ s YAG laser pulse irradiations were performed on five human eyeballs in five patients with malignant eye socket tumor and scheduled for eye removal. The cornea, lens, vitreous humor and the back of the eye of these eyeballs were all normal. Several tens of shots were made in each eyeball and observations were made immediately after the shots and after 1 hour and 24 hours.

In order to obtain accurate data, the pupil was enlarged and detailed examinations were made to check vision, the cornea, the vitreous humor and the back of the eye. Eyes with cornea diseases and with cloudy vitreous humor were rejected. A total of 426 shots were made on five eyeballs. Figures 1 and 2 show the back of one eye before irradiation and 1 hour after irradiation. The retinal injury threshold ED<sub>50</sub> was obtained by analyzing the data with a weighted linear regression method. The results are

$$ED_{50} = 1.55 \text{ mJ}$$

and the 95 percent confidence limit of ED<sub>50</sub> was

$$\Delta ED_{50} = (1.80 \text{ mJ}, 1.86 \text{ mJ})$$

The spot area of the laser entering the eye was  $\Delta S = 2.41 \text{ mm}^2$ . When the energy level reached the injury threshold, the incident laser power density was

$$P = 429 \text{ W/cm}^2$$

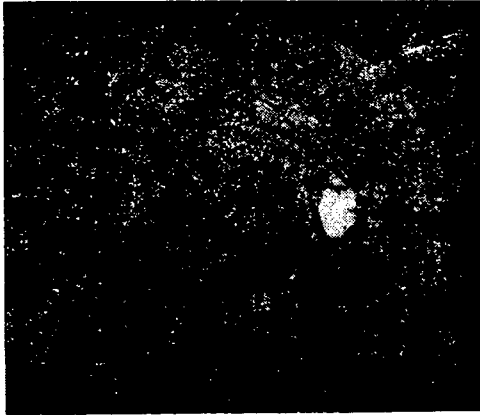

Figure 1. The right eye of a patient before laser irradiation

Figure 2. The back of the right eye 1 hour after the laser irradiation (the white spot is the laser damage)

By comparing the injury threshold of the human eye with that of rabbits and monkeys, we have

$$E_{\text{rabbit}}:E_{\text{monkey}}:E_{\text{human}} = 1.0:3.4:6.0$$

## II. Pathological Observation of Laser Retinal Damages in Rabbits, Monkeys, and Humans

Optical and electron microscope examinations were made on irradiated rabbit, monkey, and human eyes. The specimen preparation methods are as follows:

TEM specimen preparation: Specimens were taken within 4 minutes after the eyeball was removed from the body. It was first fixed in a 2.5 percent pentaldehyde and then fixed again in 1 percent osmic acid, followed by TEM observation.

Optical microscope specimen preparation: The removed eyeball was placed in an eyeball fixing solution for 24 hours. After being removed from the solution the eyeball was imbedded in collodion and then sectioned, HE stained, and examined under an optical microscope.

Observation results:

Figures 3 and 4 show the histological changes of the retina of a gray rabbit exposed to a CW YAG laser at 207 mJ for 137 ms as observed by a TEM. The magnification for Figure 3 is 1700 times. The figure shows local disarrangement of the retina pigment epithelium, swelling of the chondriosome, and cavities. The magnification of Figure 4 is 1500 times and the figure shows swelling of the endoplasmic reticulum and wrinkling of the membrane structure to become lace-like.

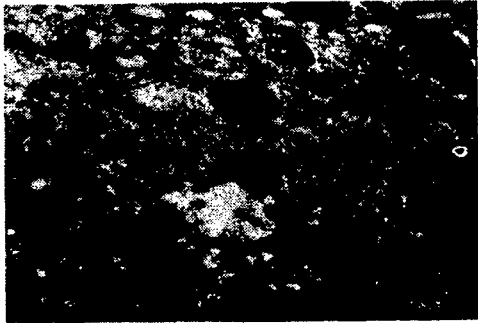

Figure 3

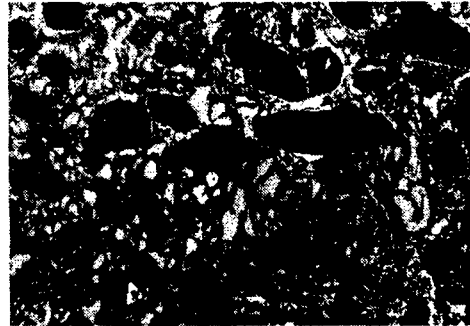

Figure 4

Figure 5 shows the retinal injury of a monkey eye observed under an optical microscope at a magnification of 200 times. The irradiation energy was 0.66 mJ. As can be seen, the structure of the retinal nerve fiber layer was disarranged. The endoplasmic reticular layer at the irradiated spot showed slight swelling and exudation. The inner membrane was intact and the inner granular layer showed noticeable changes. The number of nuclei decreased and the inner reticular layer collapsed toward the other reticular layer.

Figure 6 shows the retinal damages of a monkey eye exposed to 1.21 mJ of laser light. The inner membrane and the nerve fiber layer had suffered traumatic damages and extensive exudation. The inner granular layer showed a decrease in the number of nuclei and an indentation.

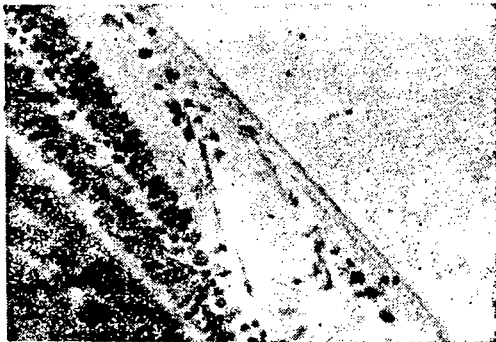

Figure 5

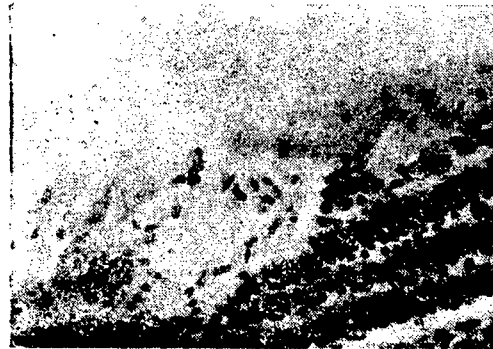

Figure 6

Figure 7 shows the retinal damages by 0.91 mJ of laser irradiation. The inner membrane was fused to the nerve fiber layer and concaved downward. The inner granular layer showed a decrease of number of cells and indentation. The outer granular layer and membrane remained normal.

Figure 8 shows the retinal injury caused by 2.17 mJ of laser irradiation. The inner membrane ruptured and the nerve fiber layer suffered severe damage. The lymph cells were infiltrated and the ganglia cells showed noticeable swelling and fragmentation. The inner granular layer was also affected somewhat.

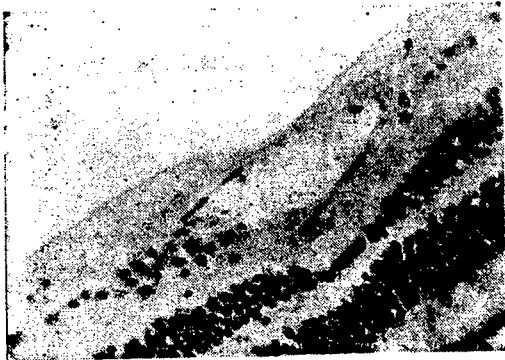

Figure 7



Figure 8

### III. Discussion of Results

Any disruption of the metabolism of the retina may lead to irreversible results. Optical microscope observations showed that lower energy laser irradiation led to local injury of the retinal nerve fiber layer. We have made consecutive sectioning and examination of the retinal damage and found that the surrounding tissues were nearly normal and unaffected. At lower energy the laser may damage the nerve fiber layer while leaving the inner membrane intact. This is because that the fiber layer tends to absorb more light energy at  $1.06 \mu\text{m}$ . As the energy increased the degree of damage increased and the number of the layers and the area damaged also increased. This showed that the physical inhibition reaction of the thermal burning caused damage in the surrounding tissue. This physical damage was directly proportional to the energy of the laser light.

The damage observed under the electron microscope was mostly pathological changes due to burn injury. The cell morphology of the retinal pigment epithelium suffered changes, the chondriosome showed irregular swelling and voids were formed. According to Kuwabara (1979), the swelling of the chondriosome and the voids may be compensated by the surrounding tissue within a few days. For severe cases this may last for several months. The endoplasmic reticulum showed swelling and the membrane structure showed wrinkles and lace-like structural changes. Even though the surrounding histocytes may play a compensating role, considerable histological disarrangement may lead to functional changes of the cells and necrosis at large energy levels. The damaged cells accumulating at the injury site can interfere with the metabolism of the light sensitive cells and disrupt the vision of the damaged region.

9698/6091

CSO: 8111/1099

STUDY OF RETINAL INJURY THRESHOLD FOR Nd:YAG FREQUENCY-DOUBLED LASER LIGHT

Shanghai ZHONGGUO JIGUANG [CHINESE JOURNAL OF LASERS] in Chinese Vol 12, No 10, 20 Oct 85 pp 618-620

[Article by Xu Jiemin [1776 4309 2404], Zhou Shuying [0719 3219 5391], Hu Fugen [5170 1381 2704], Cao Weiqun [2580 4850 5028], Chen Zongli [7115 1350 4409], Zhang Guisu [1728 2710 4790], Wang Denglong [3769 6260 7893], Qian Huanwen [6929 3562 2429], and Xu Guidao [1776 6695 6670] of the Institute of Radiation Medicine, Academy of Military Medical Sciences]

[Text] Abstract: When the eyes of rabbits and rhesus monkeys were exposed to a laser pulse with a wavelength of 0.53  $\mu\text{m}$ , the ED50 values were found to be 39.2  $\mu\text{J}/\text{cm}^2$  and 187  $\mu\text{J}/\text{cm}^2$  for rabbits and monkeys respectively. The experimental results showed that the monkey fundus is considerably less sensitive than the rabbit fundus.

This is an investigation of the retinal injury threshold in rabbits and monkeys by a Nd<sup>3+</sup>:YAG frequency doubled laser and the goal is to provide reference data for establishing a laser safety standard.

#### I. Irradiation Setup and Experimental Method

A Nd<sup>3+</sup>:YAG laser with KD\*P Q-switching and first order oscillation at 1.06  $\mu\text{m}$  wavelength was used. The output was frequency-doubled with a KDP crystal to produce 0.53  $\mu\text{m}$  green light. The pulse width was 5 ns, the beam divergence was less than 0.5 mrad, and the output was a transverse mode.

Figures 1 and 2 show the irradiation setup and the optical path. 1.06  $\mu\text{m}$  and 0.53  $\mu\text{m}$  attenuator plates were installed respectively before and after the frequency doubler and the beam splitter. The desired irradiation dosage was obtained by adjusting the charging voltage and the attenuators.

The laser dosage is given in terms of the incidence energy at the cornea. The dosage was monitored by beam splitting in real time. The dosage levels of 1,382 shots in 13 groups were measured. 496 data points in 45 groups were analyzed and the measurement errors were in the 1.7-4.8 percent range. The accuracy was adequate for the biological experiments.

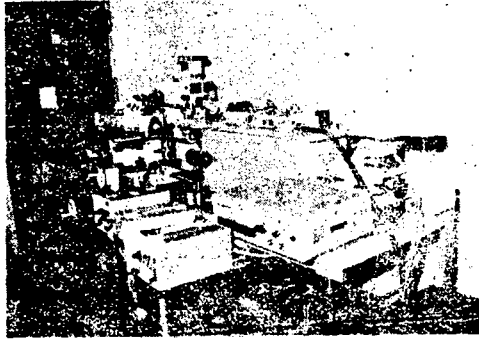

Figure 1. Irradiation setup for measuring retinal injury by  $\text{Nd}^{3+}$ :YAG frequency doubled laser

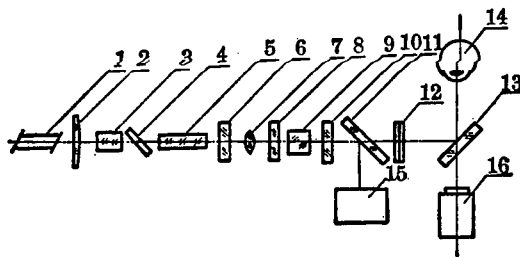

Figure 2. Optical path of the experimental setup

1--He-Ne laser; 2-7--Plano-convex unstable laser cavity; 8,12--Attenuators; 9--Frequency doubling crystal; 10--1.06  $\mu\text{m}$  filter; 11--Beam splitter; 13--Reflecting mirror; 14--Animal eyeball; 15--Energy monitor; 16--TOPCON ophthalmoscopic camera

The animals were gray rabbits weighing 2-3 kg and rhesus monkeys weighing 2-7 kg with normal eyes. Ophthalmoscopic examinations were performed 1 hour and 24 hours after the irradiation by at least two persons. A total of 530 shots was made on 70 rabbit eyes and 220 shots on 10 monkey eyes.

## II. Experimental Results

### 1. Rabbit retinal injury threshold

The average incident energy density for rabbit eyes ranged from 14.4 to 70.1  $\mu\text{J}/\text{cm}^2$  and the average incident energy ranged from 2.83 to 13.7  $\mu\text{J}$ . The lightest retinal injury indicators were small pigment rings or aggregates that disappeared mostly after 24 hours. Light injuries showed round light gray coagulating edema with some pigment precipitation at the center and an ill-defined boundary, as shown in Figure 3 [sic]. Some of the injuries disappeared after 24 hours and most formed pigment spots in 72 hours. As the dosage was increased, a small number of circular or chrysanthemum-shaped hemorrhage spots were observed.

The injury rate increased with increasing incident energy density at the cornea. Table 1 shows the dosage dependence of the retinal injury rate for 1 hour after the shots. Using a Bliss probabilistic weighted regression method, the regression equation in terms of dosage (X) and injury rate ( $\hat{Y}$ ) and the injury threshold ED50 were obtained:

$$\hat{Y} = 3.838X - 1.116$$

$$ED_{50} \approx 39.2 \mu\text{J}/\text{cm}^2$$

(95 percent confidence limit 36.5 ~ 42.1  $\mu\text{J}/\text{cm}^2$ )

The regression curves were shown in Figure 3.

Table 1. Rabbit Retinal Injury Rate and Dosage of Nd<sup>3+</sup>:YAG Frequency Doubled Laser

Group	Ave. incident dosage at the cornea		Injury rate	
	(J)	(J/cm <sup>2</sup> )	No of injuries/ No of shots	%
1	2.83x10 <sup>-6</sup>	1.44x10 <sup>-5</sup>	0/22	0
2	3.61x10 <sup>-6</sup>	1.84x10 <sup>-5</sup>	7/44	15.9
3	4.44x10 <sup>-6</sup>	2.27x10 <sup>-5</sup>	7/48	14.6
4	5.54x10 <sup>-6</sup>	2.83x10 <sup>-5</sup>	20/58	34.5
5	7.04x10 <sup>-6</sup>	3.59x10 <sup>-5</sup>	37/91	40.7
6	8.64x10 <sup>-6</sup>	4.41x10 <sup>-5</sup>	47/80	58.8
7	1.09x10 <sup>-5</sup>	5.55x10 <sup>-5</sup>	74/107	69.2
8	1.37x10 <sup>-5</sup>	7.01x10 <sup>-5</sup>	69/80	86.2

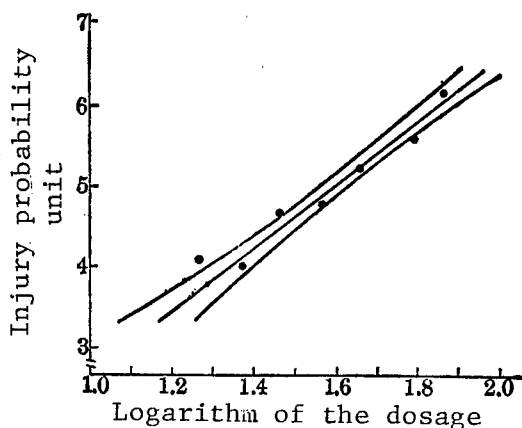

Figure 3. Rabbit retinal injury rate as a function of the irradiation dosage of a frequency doubled Nd<sup>3+</sup>:YAG laser

## 2. Monkey retinal injury threshold

The average incident energy density at the cornea of the monkey eye was 210-327  $\mu\text{J}/\text{cm}^2$  and the energy ranged from 412 to 642  $\mu\text{J}$ . Under such dosage levels, the injuries were slight and showed up as small circular light gray coagulation spots with well defined boundaries. A total of 220 shots were made and 52 coagulation injuries appeared within 1 hour. After 24 hours some of the injuries had disappeared but 13 new injury spots showed up.

Table 2 lists monkey retinal injuries occurring within 1 hour after irradiation by 0.53  $\mu\text{m}$  laser light. Using the Bliss weighted regression method, we obtained the regression equation relating the retinal coagulation injury probability ( $\hat{Y}$ ) and the logarithm of the dosage ( $x$ ). The regression curve is shown in Figure 4.

$$\hat{Y} = 2.804x - 1.373$$

$$ED_{50} \approx 187 \mu\text{J}/\text{cm}^2$$

(95 percent confidence limit = 156 ~ 238  $\mu\text{J}/\text{cm}^2$ )

Table 2. Monkey Retinal Injury Rate and Frequency Doubled  $\text{Nd}^{3+}$ :YAG Laser Dosage

Group	Ave. incident dosage at the cornea		Injury rate	
	(J)	( $\text{J}/\text{cm}^2$ )	No of injuries/ No of shots	%
1	$4.12 \times 10^{-6}$	$2.10 \times 10^{-5}$	1/59	1.69
2	$9.13 \times 10^{-6}$	$4.66 \times 10^{-5}$	2/54	3.70
3	$1.78 \times 10^{-5}$	$9.08 \times 10^{-5}$	4/31	12.9
4	$3.42 \times 10^{-5}$	$17.5 \times 10^{-5}$	27/54	50.0
5	$6.42 \times 10^{-5}$	$32.7 \times 10^{-5}$	18/22	81.8

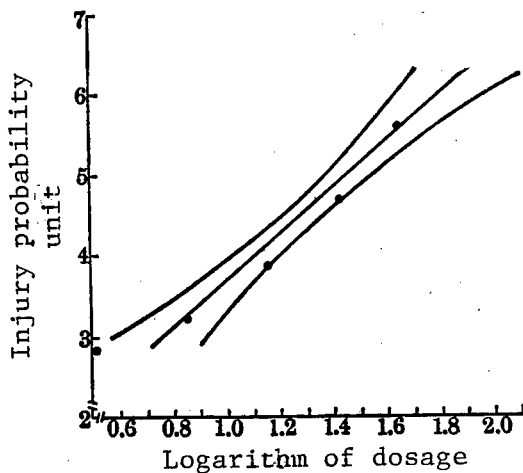

Figure 4. Monkey retinal injury rate versus logarithm of the dosage of frequency doubled  $\text{Nd}^{3+}$ :YAG laser

### 3. Pathological examination of retinal injuries

Typical indications of [rabbit] retinal injury caused by threshold dosage irradiation are exudation under the retina, swelling of the pigment epithelial cells, segregation of black pigment particles, breakage of outer section, break up of outer granular layer by edema exudation and gasification, pyenotic nucleus in inner and outer granular layers, and light bulging of the injured area. Blood vessel dilation was observed in the choroid, as shown in Figure 5. Typical injuries of the monkey retina are coagulation, edema exudation, liquid exudation under the retina, bulging of the outer granular layer, pyenotic nucleus in the outer granular layer, and a volcano mouth-shaped injury with an indented and coagulated center (see Figure 6). No obvious changes were found in the choroid.

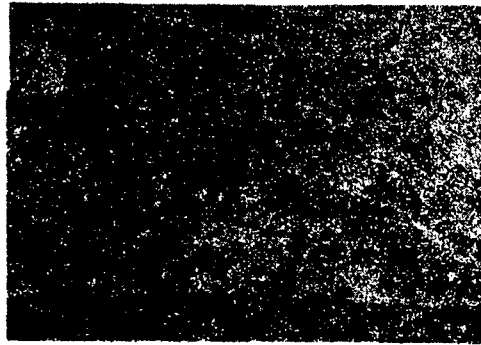

Figure 5. Injury of the rabbit retina caused by a frequency doubled Nd<sup>3+</sup>:YAG laser (x126) (Exudation under the retina, pigment segregation, gasified region, 7.28  $\mu$ J incident energy at the cornea)



Figure 6. Injury of the monkey retina caused by a frequency doubled Nd<sup>3+</sup>:YAG laser (x63) (Exudation under the retina, inner layer coagulation and indentation)

9698/6091

CSO: 8111/1099

## RETINAL INJURY THRESHOLD OF LONG PULSE RUBY LASER LIGHT

Shanghai ZHONGGUO JIGUANG [CHINESE JOURNAL OF LASERS] in Chinese Vol 12,  
No 10, 20 Oct 85 pp 621-622

[Article by Xu Jiemin [1776 4309 2404], Hu Fugen [5170 1381 2704], Zhou Shuying [0719 3219 5391], Cao Weiqun [2480 4850 5028], Qian Huanwen [6929 3562 2429], Zhang Guisu [1728 2710 4790], and Wang Denglong [3769 6260 7893] of the Institute of Radiation Medicine, Academy of Military Medical Sciences]

[Text] Abstract: Threshold of observable retinal injury was determined for rabbits exposed to long pulse ruby laser light irradiation. The threshold, ED<sub>50</sub> was 14.9 mJ/cm<sup>2</sup> and its 95 percent confidence limit was 13.6~16.5 mJ/cm<sup>2</sup> for intraocular energy density.

The wavelength of a ruby laser is 6943 Å and the damage to the eye by a ruby laser is mainly on the retina. In this work we study the rabbit retinal injury threshold by a long ruby laser pulse for the establishment of a safety standard.

### I. Experimental Setup and Method

The setup consisted of a ruby laser, a laser irradiation locating device, a copper sulfate attenuation solution, a quartz comparator, an output energy monitor system, a beam spread suppression lens, and a diaphragm (see Figures 1 and 2).

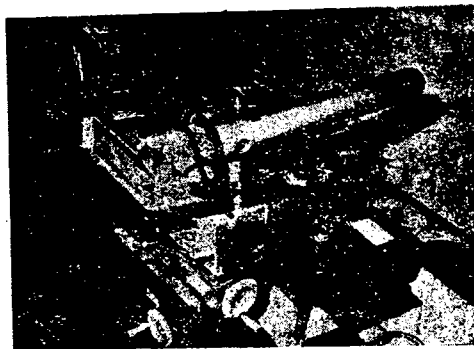

Figure 1. Ruby laser irradiation setup

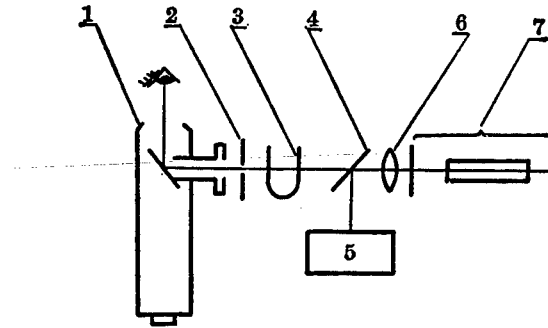

Figure 2. Schematic diagram of the optical path

1--Laser irradiation locating device; 2--Diaphragm; 3--Attenuator cup; 4--Beam splitter; 5--Monitor system; 6--Compression lens; 7--Ruby laser

The output energy of the laser was 0.1-1.8 J per pulse, the pulse width was 0.6 ms, the output was stable to within  $\pm 6.6$  percent, the divergence angle was 4.5 mrad and the beam diameter was 5 mm.

The laser irradiation locating device was used to observe the back of the eye and to select the location for the irradiation. The device consisted of an observation system, an image inversion system, and an illumination system. The magnification was 1.44 times, the field of the view angle was  $64^\circ$  and the resolution was 0.5 mm.

The laser energy was measured with a model NJ-J<sub>1</sub> thermal energy meter with a 10 mm diameter receptor, a wavelength response range from ultraviolet to infrared and a repeatability better than 0.5 percent. Within the dosage range used, the response was linear. The system was monitored with an integration sphere energy meter. The dosage of 240 shots in 5 groups were measured. Statistical analysis of 115 data points in 23 groups showed that the error in the beam splitting ratio was less than 3 percent and the measurements were reliable.

The animals were gray rabbits weighing 2-2.9 kg with normal eye examination results. No corrections were made for hyperopia (less than 2.25 D) or myopia (less than 1.0 D). Ophthalmoscopic examinations were made after 1 hour and 24 hours by at least two persons. Some of the eyeballs were removed for pathological and histological examinations. A total of 240 shots were made on 77 rabbit eyes.

## II. Experimental Results

The irradiation dosage was 11.7-25.0 mJ/cm<sup>2</sup> for the average cornea incidence and was divided into five groups.

1. Retinal injury indications: Under the ophthalmoscope, light gray or grayish white circular injury spots were visible. The boundaries had scattered black pigment particles and sometimes edema rings. A few injury

spots had a small black dot of burn spot at the center. The injury spots slightly increased their size after 24 hours, followed by recession of the edema. After 3-5 days most of the injury spots had only residual pigment deposits or formed a small white circular scar.

2. Relationship between irradiation dosage and retinal injury rate: Table 1 shows the retinal coagulation injury rate after 1 hour and the corresponding dosages. As can be seen, the retinal injury rate increased with the average incident energy density at the retina. Ophthalmoscopic examinations made 1 hour after the shots showed an injury rate of 138/240 (57.5 percent). After 24 hours the injury rate was 80.6 percent.

Table 1. Rabbit Retinal Injury Rate and Corresponding Ruby Laser Irradiation Dosages

Group	Ave. incident dosage at the cornea		Injury rate	
	(J)	(J/cm <sup>2</sup> )	No of injuries/ No of shots	%
1	4.91x10 <sup>-3</sup>	2.50x10 <sup>-2</sup>	42/48	87.5
2	3.65x10 <sup>-3</sup>	1.86x10 <sup>-2</sup>	35/54	64.8
3	3.25x10 <sup>-3</sup>	1.66x10 <sup>-2</sup>	26/52	50.0
4	2.74x10 <sup>-3</sup>	1.40x10 <sup>-2</sup>	18/42	42.9
5	2.30x10 <sup>-3</sup>	1.17x10 <sup>-2</sup>	17/44	38.6

3. Calculation of the retinal injury threshold: The injury threshold (also known as ED<sub>50</sub>) often refers to the irradiation dosage corresponding to 50 percent probability for the smallest observable injury in ophthalmoscopic examinations made 1 hour after the shot. A Bliss probability weighted regression method was used to analyze the data and the regression equation for the logarithm of the long pulse ruby laser irradiation dosage (X) and the coagulation injury probability of the rabbit retina was found:

$$\hat{P} = 4.392X - 0.0937$$

$$ED_{50} \approx 14.9 \text{ mJ/cm}^2$$

(95 percent confidence limit was 13.6~16.5 mJ/cm<sup>2</sup>)

4. Pathological changes of the injuries: The pathological changes of the injuries caused by threshold dosage irradiations were mostly on the outer layer of the retina. Edema and exudation under the retina caused slight bulging. There were swelling or rupture of the pigment epithelium cells, segregation of black pigment particles, and some local "vaporized zone." Some pyenotic nuclei occurred in the outer granular layer and in the vaporized zones. Some swelling or necrosis of the nuclei of ganglia cells and void formation in the cytoplasm were observed. Most of the outer membranes were intact and the choroid and the sclera showed no noticeable changes. Figure 3 shows a typical case.



Figure 3. Retinal injury of the rabbit eye by a ruby laser (x126) (Exudation behind the retina, pigment cell swelling and separation) (Average incidence energy density at the cornea =  $16.6 \text{ mJ/cm}^2$ )

A modified J LX ruby laser slit light microscope was used to irradiate 240 spots in 76 eyes of gray rabbits. The coagulation injury threshold for a long ruby laser pulse was found to be  $ED_{50} = 14.9 \text{ mJ/cm}^2$  with a 95 percent confidence limit of  $13.6 \sim 16.5 \text{ mJ/cm}^2$ . Injury indications and pathological changes were described.

Tang Zhongming helped with the computer statistical analysis of the data.

9698/6091

CSO: 8111/1099

## A STUDY OF SINGLE MODE He-Ne LASER INJURY THRESHOLD OF RABBIT EYE

Shanghai ZHONGGUO JIGUANG [CHINESE JOURNAL OF LASERS] in Chinese Vol 12, No 10, 20 Oct 85 pp 623-625, 585

[Article by Ding Weiling [0002 4850 3781], Zhao Tianji [6392 1131 0679], and Qiang Ruling [1730 5423 3781] of the Tianjin Institute of Laser Technology, Wu Guifang [2976 2710 5364] of the Tianjin Ophthalmic Hospital, and Liu Changting [0491 2512 1656] and Mu Ruidong [4476 3843 2639] of the Tianjin Institute of Industrial Hygiene and Occupational Diseases]

[Text] Abstract: In this study, gray rabbits were exposed to He-Ne laser light at six and five different dosages respectively. The exposure time was 1 second and 1/8 second. Thirty points were exposed for every dosage. The probability of injury to the retina at a rate of 50 percent (ED<sub>50</sub>) was obtained.

Helium-Neon lasers are most widely used today. Since the output power is generally less than 100 mW, people often overlook the danger of physical injury and eye damage by such low-power lasers. Due to the focusing effect of the eye, the power density at the retina<sup>1</sup> is increased by a factor of 10<sub>5</sub> [sic] and can cause eye injuries. After studying multimode lasers,<sup>2</sup> we now study the injury threshold of rabbit eyes by single mode He-Ne lasers as a function of exposure time.

### I. Experimental Setup and Animals

#### 1. Experimental setup

Figure 1 is a schematic diagram of the experimental setup. It consists of an illumination system, an aiming system, and an observation system.

The illumination system consists of a HN-T<sub>4</sub> He-Ne laser with a single transverse mode output power greater than 50 mW and a divergence angle less than 1 mrad, a shutter and an attenuator. The exposure time is controlled automatically by a model PKM-4 electronic shutter. The exposure time used in this experiment was 1 sec and 1/8 sec. Our fixed point illumination device consists of an alignment illumination system, an observation system, and reflection mirror #1. The aiming system makes use of a low power He-Ne laser. The aiming laser light is reflected from the semi-reflecting mirror

and follows the path of the irradiation laser and enters the pupil after bouncing off reflection mirrors #1 and #2. The experimenter may select an ideal target spot through the observation system and observe the ocular condition and injury spots. The power of the irradiation is controlled by the attenuator.

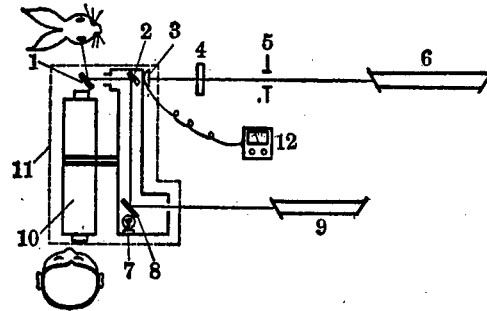

Figure 1. Schematic diagram of the experimental setup

- 1--Reflection mirror #1; 2--Reflection mirror #2; 3--Power meter probe; 4--Attenuation; 5--Electronic shutter; 6--HN-T<sub>4</sub> He-Ne laser; 7--Lamp; 8--Semi-reflecting mirror; 9--Alignment He-Ne laser; 10--Observation system; 11--Fixed point illumination setup; 12--Power meter

The measurement of the laser power is made with our own miniature photoelectric power meter with an error of  $\pm 5$  percent. The probe of the power meter is mounted on the fixed point irradiation setup and real time monitoring is realized. The laser power entering the cornea may be obtained from the measured power and a correction factor.

The light beam for irradiation is the original beam of the laser, as shown in Figure 2. The light intensity has a Gaussian distribution in the radial direction. The diameter of the light spot is taken as the distance between the two  $1/e^2$  points of the maximum power. The diameter of the light spot at the cornea is computed to be 4.30 mm and the area of the spot is 0.145 cm<sup>2</sup>.

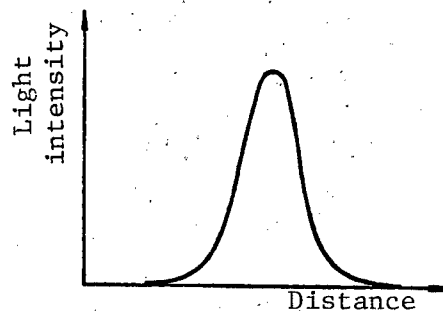

Figure 2. Light intensity distribution of the cross-section of the beam

## 2. Experimental animals

Small gray chinchilla rabbits bred at the Shanghai Breeding Facility were carefully selected to meet the following requirements: 1) weight is in the 2-2.5 kg range; 2) ocular pigments are similar, free from cornea, lens, and vitreous abnormalities or ocular diseases; 3) diopter in the +15 to +30 range and axis length in the 15-17 cm range.

## II. Experimental Method and Procedures

Before exposure the irradiation laser and the aiming laser are aligned. The animal is first put under total anesthesia, the pupil sufficiently enlarged and then held on the platform with five degrees of freedom. The experimenter then chooses the ocular spot for exposure by adjusting the platform position. The exposure is controlled by an electronic shutter, as shown in Figure 3. Three observations are made of the rabbit eye immediately after the exposure and 30 and 60 minutes after the exposure. A positive reaction is recorded when two ophthalmologists observe the presence of a small light gray injury spot.

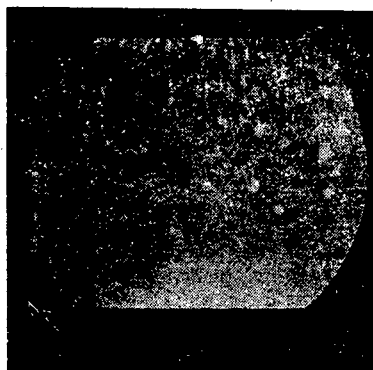

Figure 3. Retinal injury of the rabbit eye

The pathological specimens are taken using a modified retinal opening location method. The experiment first aims the ophthalmoscopic beam at the center of the injury spot and then observes the light spots going through the sclera. The spot is marked with gentian violet and sutures are made with a cornea needle at this location. After the localization, the animal is put to death by an intravenous injection of air and the eyeball removed after the blood has coagulated. The eyeball is fixed with a 10 percent formalin solution, embedded in paraffin and the injured location is sectioned and stained with H-E.

## III. Experimental Results

### 1. 1 second exposures

A total of 30 eyeballs from 15 rabbits are exposed to the laser radiation at six dosage levels. The rabbits are divided randomly into three groups of five.

Each eye is exposed to two different dosages at three spots. The distance between the spots are greater than the diameter of the injury spots by at least a factor of 2. A total of 30 shots are made at each dosage level. The results are listed in Table 1.

Table 1. Acute Retinal Injury of Rabbit Eyes by He-Ne Laser

<u>Laser power (mW)</u>	<u>Power density (mW/cm<sup>2</sup>)</u>	<u>No of shots</u>	<u>No of injuries</u>	<u>Positive reaction (%)</u>
38.0	262	30	28	93.3
30.0	207	30	21	70.0
27.0	186	30	18	60.0
24.0	166	30	14	46.7
20.0	138	30	3	10.0
15.0	103	30	0	0

The results in Table 1 show that the injury rate versus the irradiation dosage is an S-shaped curve. No cornea, lens, or vitreous damages were observed after the irradiation. The 6328 Å radiation only causes retinal injury.<sup>3</sup> A weighted linear regression analysis of the data on the micro-computer yielded a regression equation of  $\hat{y} = -8.19 + 9.32 x$ , an ED<sub>50</sub> value of 26.0 mW (or 179 mW/cm<sup>2</sup>) and a confidence limit of 24.5~27.5 mW (or 169~190 mW/cm<sup>2</sup>). The correlation coefficient of the regression straight line is  $r = 0.988$ , indicating that the results are reliable.

## 2. 1/8 sec shots

Thirty eyes of 15 gray chinchilla rabbits are exposed to five different dosage levels for 1/8 sec in the same manner as the 1 sec exposures. The results are listed in Table 2.

Table 2. Acute Retinal Injury of Rabbit Eyes Exposed to He-Ne Laser for 1/8 Sec

<u>Laser power (mW)</u>	<u>Power density (mW/cm<sup>2</sup>)</u>	<u>No of shots</u>	<u>No of injuries</u>	<u>Positive reaction (%)</u>
43.0	297	30	30	100
38.0	262	30	24	80.0
33.0	228	30	20	66.7
28.0	193	30	10	33.3
23.0	159	30	0	0

The results of Table 2 show that, like the 1 sec exposure results, the injury versus the irradiation dosage is again an S-shaped curve. The linear regression equation is  $\hat{y} = -15.8 + 14.0 x$ , the ED<sub>50</sub> value is 31.2 mW (or 215 mW/cm<sup>2</sup>), and the confidence limit is 29.8~32.6 mW (or 206~225 mW/cm<sup>2</sup>).

### 3. Pathological changes observed ophthalmoscopically

Based on the ED<sub>50</sub> confidence limit of the 1 second exposures, three dosages of 27, 25, and 23 mW are chosen. The retinal injuries at these dosages are:

27 mW--Retinal injuries are observable under a low power microscope. The choroid and the sclera are fused together and the epithelium is ruptured. Under a high power microscope, edema of the nerve fiber layer and disarrangement of the outer granular layer are also observed.

25 mW--Injuries observed at the irradiated location include retinal bulging, edema, hemorrhage under the retina, local retinal detachment, separation of the outer granular layer, growth of the collagen cells, local pleiomorphic nuclear infiltration of the choroid, and changes of the ganglia cells.

23 mW--Light edema of the retina, epithelium rupture, and local pleiomorphic nuclear infiltration of the choroid.

The results show that pathological changes are observed under the light microscope at retinal injuries found under the ophthalmoscope. In addition, retinal edema, hemorrhage and pleiomorphic nuclear infiltration of the choroid are observed. Due to the limited number of pathological specimens, no correlation between pathological changes and laser power is observed.

### IV. Discussion

1. In our study of the retinal injury threshold of rabbit eyes due to He-Ne laser irradiation, we found that the injury not only depends on the laser power, the divergence angle, the ocular pigment, but also depends on the laser mode, the irradiation location, and the exposure time.

2. In the pathological observation we found that specimen preparation was crucial. Our procedures were laser irradiation, exposing the sclera surface, localization, killing the animal, and removing the eyeball. The advantages of this method are: 1) accurate localization, 2) short time duration, and 3) making use of the favorable conditions of the rabbit eye.

3. Based on extensive data from animal experiments and based on the fact that the eye is one of the most important organs of the human body, we believe that the safety level should be 100 times lower than the lower limit of the 95 percent confidence range of the minimum injury threshold (ED<sub>1</sub>). We therefore recommend that the maximum allowable irradiation dosage of He-Ne laser in China should be  $8.76 \times 10^{-4}$  W/cm<sup>2</sup> for 1 second exposure and  $13.0 \times 10^{-4}$  W/cm<sup>2</sup> for 1/8 second exposure. This standard is slightly more stringent than the U.S. standard.

### REFERENCES

1. M.L. Wolbarsht, "Laser Applications in Medicine and Biology," 1971.

2. Liu Changting, et al., "Occupational Hygiene and Environmental Medicine," No 1, 1 (1983).
3. A. Kohtiao, et al., Amer. J. Ophthal., 1966, 62, 524-527.
4. W.P. Hansen, et al., Appl. Opt., 1976, 6, 1973-1975.

9698/6091

CSO: 8111/1099

RESEARCH ON INJURY THRESHOLD OF CHINESE YELLOW SKIN BY CW Nd:YAG LASER BEAM IRRADIATION

Shanghai ZHONGGUO JIGUANG [CHINESE JOURNAL OF LASERS] in Chinese Vol 12, No 10, 20 Oct 85 pp 626-628

[Article by Wu Tingbi [0702 1694 1084], Li Yujun [2621 3768 0193], Dang Zhiping [7825 3112 1627], An Xiaoyue [1344 2556 1471], Guo Wenqi [6753 2429 3823] of the Xi'an Medical University Hospital No 1, Medical Laser Research Laboratory, and Wang Kejin [3769 0344 3866] of the Dermatology Group, Liang Luanxian [2733 7762 0103], Wang Peng [3769 7720], and Chen Mingxia [7115 2492 7209] of the Electron Microscope Laboratory, Xi'an Medical University, Xu Linmiao [1776 2651 5379] of the Xi'an Fifth Ministry of Machine Building, and Lu Zhiguo [7120 3112 0948] of the Laser Laboratory, Physics Department, Northwest University]

[Text] Abstract: This paper deals with laser injury threshold for Chinese yellow skin by exposure to 1 sec CW Nd:YAG laser beam. The results of the experiment are: MRD equals to  $71.37 \text{ W/cm}^2$ , and its 95 percent confidence limit is  $67.47 \sim 75.49 \text{ W/cm}^2$ .

I. Experiment

1. CW YAG laser

Single lamp cavity, 100 mm long by 6 mm diameter, output power  $\sim 30 \text{ W}$ , lower order modes, stability better than  $\pm 1$  percent with feedback control.

2. Optical path

(1) CW YAG laser, (2) electromagnetic shutter for exposure time control, digital millisecond counter for exposure time monitor, (3) 5 mm diameter diaphragm, (4) two beam splitters in the optical path to direct lights into the power monitor and the feedback system (see Figure 1).

3. There were 10 volunteers, five males and five females, 19-57 years old, half the volunteers had a light complexion and the other half had a dark complexion. The inner surface of the right arm was divided into three rows with eight zones in each row. Each volunteer was exposed for 24 shots. Each power dosage group had 30 shots and a total of 240 shots were made.

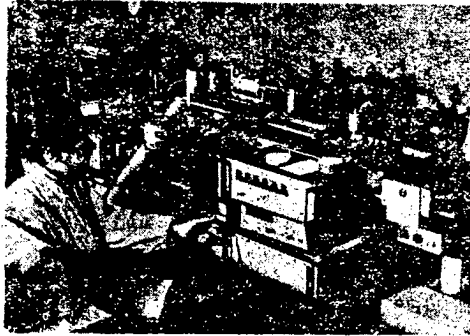

Figure 1

4. Observation time: Each irradiation location was observed 22 times-- immediately after the exposure (1 observation), 6 observations within the first minute, 9 observations within the first hour, and 6 observations within the first day.

5. Injury classification: Ambiguous ( $\pm 1$ ), erythema (+), blister (++) , and ulcer (+++).

6. Ambient conditions: Ventilation, dust guard,  $20^{\circ}\text{C} \pm 1.0^{\circ}\text{C}$ , 60-64 percent relative humidity.

## II. Experimental Observation Results

Table 1 lists the experimental observation results. (See next page).

## III. Statistical Analysis of Data

A weighted regression method yielded  $\text{MRD}_{50}$  of  $71.37 \text{ W/cm}^2$  and a 95 percent confidence limit of  $67.47 \sim 75.49 \text{ W/cm}^2$ .

## IV. Measurement of the Skin Reflectivity

Listed in Table 2 are the skin reflectivity measured on the forearms of volunteers using a CW YAG laser.

Table 2

<u>Location</u>	<u>Outer row</u>	<u>Middle row</u>	<u>Inner row</u>
Average value	41.1%	41.7%	40.8%

Note: The laser power absorbed by the skin = measured power - (measured power x reflectivity)

Table 1. Human Skin Injury Threshold by 1 Sec Exposure of a CW YAG Laser

Power W/ φ5mm	Power density W/ cm <sup>2</sup>	No. of shots	Temporal distribution for erythema occurrence																								Max. No. of reactions	Reaction rate		
			Minute												Hour														Day	
			Inst	5	10	15	20	25	30	~59	1	2	3	4	5	6	12	18	~24	1	2	3	4	5	6					
19.00	96.77	30	23	26	24	20	18	18	18	18	18	18	18	18	18	18	18	18	18	18	18	18	18	18	18	18	26	86.7		
17.21	87.65	30	19	23	23	21	22	20	17	16	16	16	16	16	16	16	16	16	16	16	16	16	16	16	16	16	25	83.3		
15.58	79.85	30	19	19	19	19	18	18	19	16	13	11	10	9	11	10	9	9	8	8	9	8	8	8	8	8	19	63.3		
14.11	71.86	30	11	12	13	13	11	9	9	9	8	6	6	6	6	6	6	6	6	6	6	6	6	6	6	6	15	50.0		
12.78	65.09	30	10	11	11	12	12	11	10	11	6	5	5	5	5	5	5	5	4	4	4	4	4	4	4	4	13	43.3		
11.57	58.93	30	2	2	3	3	4	2	2	2	2	1	0	0	0	0	0	0	0	0	0	0	0	0	0	5	16.1			
10.48	53.37	30	1	2	2	2	1	1	1	1	0	0	0	0	0	0	0	0	1	1	1	1	1	1	1	4	13.3			
9.49	48.33	30	2	2	2	3	3	3	3	3	2	2	2	2	2	2	2	2	2	2	2	2	2	2	2	3	10.0			
Total No. of reactions		87	97	97	98	89	82	79	73	65	58	57	55	57	50	48	46	45	43	46	45	45	45	41	42					
Reaction rate		36.2	40.4	40.4	39	37	34.1	33	30	27.1	24.2	23.8	22.9	23.8	20.8	20.0	19.1	18.8	17.9	19.1	18.8	18.8	17.1	17.5						

## V. Pathological Changes of Erythema Near Threshold

### (1) Optical microscope observations

Halos around the nuclei of basal cells and prickle cells. Slight edema between the cells, dilation and congestion of papillary vessels, and occasionally blood vessel congestion under the papillary corii.

### (2) Electron microscope observation

Small bubbles were observed in the cytoplasm of the prickle cells. The link node of some prickle cells showed noticeable damage (Figures 2-266, 2-270) and most basal cells showed bubbles in the cytoplasm. The gap between some basal cells had widened and rarefied. Portions or most of the link node structures were damaged (Figures 2-620, 2-624).



Figure 2-266. Three bubbles observed in the prickle cell. No obvious changes between the cells were observed. (5000x)

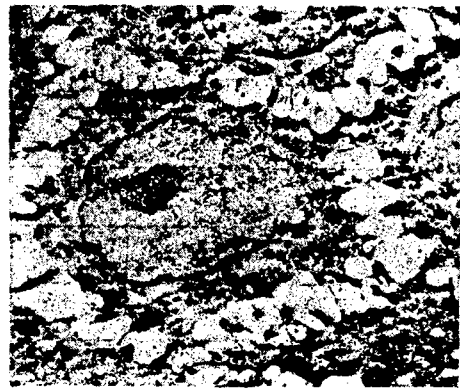

Figure 2-270. Most of the connecting structures between prickle cells were damaged

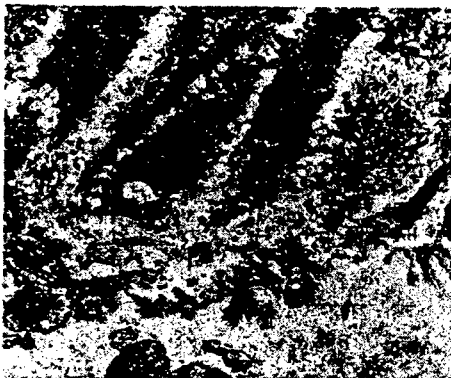

Figure 2-620. Slight shrinkage of the basal cells and bubbles in the cytoplasm were observed. Connecting structures between basal cells were rarefied. (3000x)

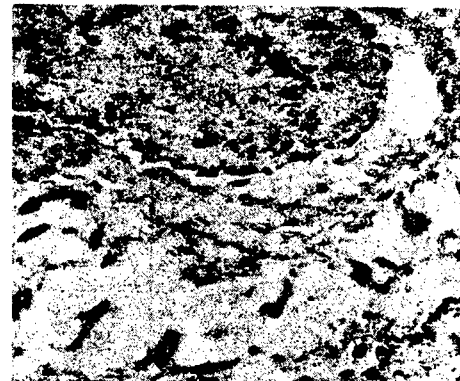

Figure 2-624. Three bubbles were seen in the basal cell cytoplasm. Connecting structures between cells were destroyed. (10000x)

In 1974 Rockwell and Goldman reported a study of the skin injury threshold by 1 sec exposure of CW YAG lasers. They showed that the threshold was 48-78 W/cm<sup>2</sup> for Caucasians and 46-60 W/cm<sup>2</sup> for blacks. We obtained a MRD threshold of 67.47-75.49 W/cm<sup>2</sup> for the Chinese and the value falls between those of the blacks and the Caucasians and close to the Caucasians. The result seemed reasonable.

The authors acknowledge the collaboration of the Northwest University, Institute No 205 of the Ministry of Ordnance Industry, the Northwest Military Communication Engineering College, the Shaanxi Teacher's University, and the Xi'an Dongfeng Meter Plant.

9698/6091

CSO: 8111/1099

RESEARCH ON INJURY THRESHOLD OF CHINESE YELLOW SKIN IRRADIATED WITH 300  $\mu$ s  
PULSED NEODYMIUM GLASS LASER LIGHT

Shanghai ZHONGGUO JIGUANG [CHINESE JOURNAL OF LASERS] in Chinese Vol 12,  
No 10, 20 Oct 85 pp 628-630

[Article by Wu Tingbi [0702 1694 1084], Li Yujun [2621 3768 0193], Dang Zhiping [7825 3112 1627], and Guo Wenqi [6753 2429 3823] of the Medical Laser Research Laboratory, Xi'an Medical University Hospital No 1, Liang Luanxian [2733 7762 0103], Wang Xinhui [3769 2450 2585], and Wang Peng [3769 7720] of the Electron Microscope Laboratory, Xi'an Medical University, Wang Kejin [3769 0344 3866] of the Dermatology Laboratory, Xi'an Medical University Hospital No 1, Liu Shikai [0491 1102 2818] of Institute 213, Xi'an Ministry of Ordnance Industry, and Lian Rulin [1670 3067 2651] of Institute 205, Xi'an Ministry of Ordnance Industry]

[Text] Abstract: This paper studies laser injury threshold of 300  $\mu$ s pulsed neodymium glass laser. The experimental results are: MRD equals to 20.27 J/cm<sup>2</sup>, and its 95 percent confidence limit is 19.49~21.08 J/cm<sup>2</sup>.

Pulsed Nd:glass lasers have a large output energy and a strong penetrating power and can cause severe damage. They are therefore important lasers to consider from a safety point of view. The skin injury threshold depends on the exposure time and the dosage. The injury threshold is often taken as the dosage causing 50 percent erythema reactions. The maximum allowable dosage is obtained by first finding the ED<sub>50</sub> or MRD<sub>50</sub> and then multiplying this dosage by a safety factor.

#### I. Experimental Conditions

1. Pulsed Nd:glass laser: Pulse width 300  $\mu$ s, output energy ~35 J, stability better than 2.5 percent, and repetition rate one shot in every 5 minutes.
2. Optical path: (1) The irradiation light source was a Nd:glass laser and the indicating light source was a He-Ne laser. (2) Beam splitters were used to tap off the monitor beam. (3) A focusing lens was added. (4) A 5 mm diameter limiting aperture was used. (5) A three-degrees-of-freedom platform was used for accurate positioning.

3. Eight volunteers, five males and three females, 19-57 years old participated in the experiments. Half of the volunteers had a dark complexion and the other half a light complexion. The inner surface of the left forearm was chosen for the irradiation. The area was divided into three rows with eight zones per row. Each volunteer was exposed to 24 shots. Together with the six shots for determining the upper limit, a total of 198 shots was made. Four standby volunteers were subjected to 12 shots each. The observations were made by dermatologists and supplemented by the experimenters.

4. Observation time: Each shot was observed 22 times immediately after the shot, six observations within the first minute, nine observations within the first hour, and six observations in the first day.

5. Injury classifications: Questionable ( $\pm 1$ ), erythema (+), blister (++), and ulcer (+++).

6. Experimental conditions: The room temperature was kept between 12°C and 22°C, and the relative humidity was 67-72 percent.

## II. Experimental Observation and Results

Table 1 lists the experimental results of delayed erythema injuries.

## III. Histological and Pathological Changes

1. Light microscope observations: In the erythema specimens caused by threshold level dosages, extremely small bubbles were observed in the cytoplasm of the prickle cells in the lower portion of the cuticle. Noticeable deformation of cells in the granular layer was observed. Spare fissures and capillary congestion were seen at the top of the papilla corii.

2. Electron microscope observations: A number of bubbles (recessional changes) were observed in the cytoplasm of the generating cells. At locations the links between the generating cells and the basal cells had rarefied. The connecting structure suffered light damage and voids appeared in the cytoplasm of fibrous cells in the dermis.

## IV. Results and Discussion

1. Statistical analysis of the data yielded the results in Table 2.

The ED<sub>50</sub> of 19.032~21.48 J/cm<sup>2</sup> obtained in this work is quite close to the international standard.

2. The Nd:glass laser produces a near infrared light of 1.06  $\mu\text{m}$  wavelength. Some researchers believe that, like a YAG laser, the biological effect of the Nd:glass laser is in causing persistent delayed erythema. The erythema usually appear 10 minutes after the irradiation and last about 1 day. The erythema that appear 1-2 minutes after the laser shot are extremely weak, about half of them disappear within 10 minutes and all of them vanish



after 25 minutes. Such temporary reversible weak erythema may be due to a heating effect of the blood vessels. Since no pathological changes can be seen, it is debatable whether they can be considered an erythema associated with the injury threshold.

Table 2

<u>Laser type</u>	<u>Exposure method and skin type</u>	<u>Wavelength (μm)</u>	<u>Exposure time (sec)</u>	<u>ED50 or MRD50 (J/cm<sup>2</sup>)</u>
Nd:glass	Ordinary pulse, yellow skin	1.06	3x10 <sup>-4</sup>	ED50 20.27 19.49~21.08 MRD50 13.28 11.86~14.86

9698/6091

CSO: 8111/1099

## INJURY THRESHOLD OF RUBY LASER IRRADIATION ON PIG SKIN

Shanghai ZHONGGUO JIGUANG [CHINESE JOURNAL OF LASERS] in Chinese Vol 12, No 10, 20 Oct 85 pp 631-632

[Article by Wang Jun [3769 6511], Chen Ji [7115 6619], Lu Shanfen [4151 0810 5358], Xu Yidao [1776 6695 6670], Shi Liangshun [2457 5328 7311], Qian Huanwen [6929 3562 2429], and Wang Denglong [3769 6260 7893] of the Institute of Radiation Medicine, Military Medical Science University]

[Text] Abstract: This paper reports the experimental results of pig skin exposed to ruby laser light. By statistical analysis of the erythema produced within 24 hours post-exposures, ED<sub>50</sub> about 53.3 J/cm<sup>2</sup> was obtained. The microscopic and scanning electron microscopic examinations showed nothing but the blood vessels dilation of derma after a near threshold-dose irradiation on skin.

The wavelength of the ruby laser is 694.3 nm. Upon incidence on the skin surface, 99 percent of the energy are absorbed in a shallow layer 3.6 mm thick. The main characteristics of the skin effect include darkening of the pigment, precipitation of the pigment, photo-allergic reactions and burns.<sup>1</sup> In this experiment we observed the skin reaction of the white pig irradiated by a ruby laser and obtained the 50 percent erythema dose (ED<sub>50</sub>).

### I. Experiment

1. Laser: Ruby laser, working medium dimension = 530 mm x 21.5 mm diameter, Xenon pump, multi-mode output. Pulse width = 0.32 ms, spot diameter = 0.5 cm, output stability better than ±5 percent.
2. Animals: Eight young white pigs of the Changbai species, both males and females, weighing 4.6 ± 0.8 kg. Three more pigs for histological specimens only. The animals were put under total anesthesia by injecting 3 percent penta-sodium barbiturate solution (45 mg/kg). The skin was shaven, cleaned and painted with a square lattice of 2.5 cm spacing. A total of 64 grids were painted on the two sides of the body. A total of 210 shots in five dosage groups were made along the diagonal direction.

## II. Results

Macroscopic observations made immediately after the irradiation produced the results in Table 1.

Table 1. Erythema Occurrence Rate of the Pig Skin Irradiated With a Ruby Laser

<u>Group</u>	<u>Ave. dosage <math>\pm S_x</math> (J/cm<sup>2</sup>)</u>	<u>Ave. absorption <math>\pm S_x</math> (J/cm<sup>2</sup>)</u>	<u>No of shots</u>	<u>Occurrence rate (%)</u>
1	66.2 $\pm$ 1.4	35.3 $\pm$ 0.8	41	87.8
2	59.6 $\pm$ 2.0	31.8 $\pm$ 1.1	40	60.0
3	51.4 $\pm$ 1.3	27.4 $\pm$ 0.7	43	48.8
4	45.7 $\pm$ 1.3	24.4 $\pm$ 0.7	42	31.0
5	41.0 $\pm$ 2.0	21.9 $\pm$ 1.1	44	4.54

The erythema occurrence rate at the minimum dosage (41.0 J/cm<sup>2</sup>) was 4.54 percent. The erythema were uniform and pink in color with a diameter of 5 mm. Individual dark red spots had a diameter of about 2 mm. This group of erythema lasted for a relatively short time, generally 8-31 hours.

Irradiations at the maximum dosage (66.2 J/cm<sup>2</sup>) produced red patches about 7x8 mm with irregular shapes. As time went on the redness became smaller and darker in color. It shrank to a size of 2x2 mm after 10 minutes. The boundary became clear and the color darkened, sometimes to cherry red. Some of the irradiated spots bulged up and the skin at the center of the bulge appeared almost transparent. The erythema rate at the highest dosage was 87.8 percent. The redness persisted longer, generally 24-72 hours and sometimes 4-5 days.

Erythema produced by the intermediate dosage (51.4 J/cm<sup>2</sup>) were red or light red in color, 5 mm in diameter, up to 8 mm, the occurrence rate was 48.8 percent, and the redness persisted for 9 hours up to 4 days.

Histological observations were made on specimens taken immediately after the irradiation and 1-2 hours and 24 hours after the irradiation.

### (1) Optical microscopic examination

Group 1 (66.2 J/cm<sup>2</sup>): Basal cells became more rounded and flattened. The number of bubbles in the basal cells increased and pyenotic nuclei were observed. Hypodermic blood vessels showed noticeable dilation and extravasation. Infected cells surrounded the vessel cavity. Some connective structure cells became stained. The region of blood vessel dilation had a clear boundary and no edema of the papilla corii were observed.

Group 2 (59.6 J/cm<sup>2</sup>): The surface skin became somewhat thinner. The number of bubbles (voids) in the cell increased. The hypodermic blood vessels showed dilation, extravasation, and aggregation of infectious cells.

Group 3 (51.4 J/cm<sup>2</sup>): Very few bubbles in the basal cells. Blood vessel dilation remained visible in the dermis but infectious reactions became less obvious (see Figure 1).



Figure 1. Ten minutes after irradiation at 50.8 J/cm<sup>2</sup>. Hypodermic blood vessel dilation and extravasated blood were clearly visible. Infectious cell reaction not obvious.

Groups 4 and 5 (45.7 and 41.0 J/cm<sup>2</sup>): No obvious changes on the surface. Hypodermic blood vessel dilation and extravasation were obvious. Very few infectious cells were observed.

(2) SEM examinations: The erythema of group 1 and group 3 were examined using an SEM.

Group 1 (66.2 J/cm<sup>2</sup>): The irradiated skin swelled up and the surface became rough or honeycomb-like. The skin hair became sparse and the remaining hair became curly, and the sheaths became detached.

Group 3 (51.4 J/cm<sup>2</sup>): Skin surface swelled slightly. The center of the irradiated region showed slight indentation. The hair sheaths remained intact and hair loss was insignificant (see Figure 2).



Figure 2. SEM photo of a specimen taken immediately after 52.4 J/cm<sup>2</sup> irradiation. The skin surface swelled, the texture became ill-defined, the center of the irradiated region showed a slight indentation, the hair loss was insignificant, and the sheaths remained intact.

### III. Discussion

Over the years very little had been reported on the injury threshold of the pig skin by ruby laser light. The reports are either pure destructive damage at high power levels<sup>2</sup> of 64-318 J/cm<sup>2</sup> or multiple pulse irradiation.<sup>3</sup> Such data cannot be used in the evaluation of the minimum erythema dosage. By visual observation, Kuhn<sup>4</sup> found that the dosage for light injury was 42-190 J/cm<sup>2</sup>. Kuhn also found that the dosage was 50-100 J/cm<sup>2</sup> by microscopic observation. Our dosage is essentially the lower limit of Kuhn's dosage for light injury.

The factors affecting the occurrence rate of erythema are:

(1) Erythema retention time: We used the recommendation made by the 1983 national conference on laser safety that the erythema retention time must be at least 1 hour. In fact we found some erythema that disappeared within 1 hour or even 10 minutes. If such short retention erythema are also counted, the value of ED<sub>50</sub> will be reduced to 41.0 J/cm<sup>2</sup>. The mechanism of the short retention erythema calls for further study.

(2) Irradiation location: At the same dosage level, the occurrence rate varied greatly with irradiation location. Erythema occurred more in bony regions with an occurrence rate as high as 60-100 percent. In regions of soft tissue, the erythema occurrence rate is only 0 to 25 percent. An even distribution of the irradiation locations should therefore be used in the experiment.

As far as the dosage calculation, we used the experimental data on pigs as a transition to that of humans. Although the thickness, optical and thermal properties of the pig skin are similar to those of the human skin, there are significant differences in the hair, the density of the collagen fibers under the skin, and the blood vessel distribution.<sup>5</sup> One must therefore exercise caution in extrapolating the data of a pig model to the human. We have measured the reflectivity for all the animals used in our tests. The average reflectivity of the pig skin is 46.7 percent whereas that of the human is 38.8 percent. Since the pig skin and the human skin have histological differences and the reflectivity of the former is higher than the latter, we used the minimum dosage of the pig as the upper limit dosage for the humans. Our data show that when the minimum absorption dosage of the pig (21.3 J/cm<sup>2</sup>, Table 1) is multiplied by the absorptivity of the human skin, the result 13.3 J/cm<sup>2</sup> is quite close to the upper limit dosage 14.0 J/cm<sup>2</sup> of the human skin.<sup>7</sup>

In addition, an analysis of the existing threshold data shows that when the human skin is subjected to a radiation dosage of 2.6-14.0 J/cm<sup>2</sup>, it is 4-5 times lower than the dosage for a white pig skin and the thresholds differ by a factor of 11.3. The threshold of the white pig differs from that of the Caucasian skin by a factor<sup>8</sup> of 2.7-4.8, and from that of the black skin by a factor<sup>8</sup> of 7.6-24.2. The ED<sub>50</sub> of a white pig is therefore very close to the ED<sub>50</sub> of a Caucasian but differs somewhat more from the ED<sub>50</sub> of yellow and black skin. More experimental data are needed to aid the proper selection of animals and the conversion of animal data to that for the human.

#### REFERENCES

1. J.S. Michael, "Nonionizing Radiation Protection," 1982, 39.
2. E.B. Helwig, et al., "Anatomic and Histochemical Changes in Skin After Laser-Irradiation," Fed. Proc. (Suppl. 14), 1965, 24, s-83.
3. A.N. Takata, et al., "Laser-Induced Thermal Damage of Skin," AD A054 612, 1977.
4. J.G. Kuhn, et al., "Laser Injury in Skin," Lab. Invest., 1967, 17 (1), 1.
5. W. Iliam Montagna, "The Skin of the Domestic Pig," J. Invest. Dermatology, 1964, 43, 11.
6. W. Blum, "Histology," translated by Wang Qiyuan, Scientific Publishing Company, 1984.
7. Chen Ji, et al., Ibid., p 596.
8. R.J. Rochwell, et al., "Research on Human Skin Laser Damage Thresholds," ADA-012703 (p 8947), 1974.

9698/6091

CSO: 8111/1099

MORPHOLOGICAL ANALYSIS OF RETINAL INJURY IN RABBITS ARISING FROM ARGON LASER IRRADIATION

Shanghai ZHONGGUO JIGUANG [CHINESE JOURNAL OF LASERS] in Chinese Vol 12, No 10, 20 Oct 85 pp 633-634

[Article by Zhang Xiaoru [1728 1321 0320], Zhao Tongzhen [6392 2717 4176], and Guo Wenqi [6753 2429 3823] of Xi'an Medical University Hospital No 1]

[Text] Abstract: The pathological changes of retinal injury arising from argon laser irradiation with various laser densities and exposure time, and the characteristics of retinal biological effect arising from the irradiation are reported.

Lasers can cause retinal damages in humans, as proven by some of the eye injuries suffered by laser workers.<sup>1,2</sup> It is therefore important to explore the pathological changes of injury spots visible (and visible) under an ophthalmoscope. The study of the retinal changes caused by low level laser radiation are also important for laser safety and retinal injury treatment.

### I. Experimental Results

According to the medium through which the laser passes, the experiments are divided into two groups.

#### Group A: with pre-lens

Eight rabbit eyes were irradiated with different exposure time and dosage. The cornea injury thresholds were  $6.54 \text{ W/cm}^2$  for 0.145 sec and  $4.827 \text{ W/cm}^2$  for 1 sec. Table 1 shows that the length of the retinal injury is proportional to the laser dosage. The degree of injury depends on the threshold value. The injuries are more severe when the dosage is greater than the threshold, and vice versa. Injuries caused by adjacent dosages above and below the threshold (cases 1 and 2, and 5 and 6) are similar. At the same dosage, the injury becomes more severe (cases 7 and 8) when the exposure time is increased. In addition to the retinal injury, the choroid blood vessels also show significant dilation and extravasation.

Table 1. Retinal Injuries in Rabbits 1 Hour After an Argon Laser Irradiation Through a Slit Lamp and a Pre-Lens

<u>Case</u>	<u>Dosage (W/cm<sup>2</sup>)</u>	<u>Exposure time (sec)</u>	<u>Length of damage (μm)</u>	<u>Damage level</u>	<u>Exudation</u>
1	8.09	0.145	300	II	-
2	6.85	0.145	230	II	-
3	6.54	0.145	130	I	-
4	6.54	0.145	50	I	-
5	5.8	0.145	120	I	-
6	4.92	0.145	100	I	-
7	4.827	1	170	III	-
8	4.827	1	300	III	-

Group B: with contact lens

Four rabbit eyes were irradiated for 1 second with the laser passing through a contact lens. Ophthalmoscopic observations showed that the retinal injury threshold is 28.3 W/cm<sup>2</sup>. The results are summarized in Table 2. Even though the dosages are different, there are certain common features of the injuries caused by the laser passing through a pre-lens and a contact lens. Within a certain dosage range, adjacent dosage levels cause similar injuries.

Table 2. Retinal Injuries in Rabbits 24 Hours After an Argon Laser Irradiation Through a Slit Lamp and a Contact Lens

<u>Case</u>	<u>Dosage (W/cm<sup>2</sup>)</u>	<u>Exposure time (sec)</u>	<u>Length of injury (μm)</u>	<u>Damage level</u>	<u>Exudation</u>
1	26	1	250	I	-
2	26	1	200	I~II	-
3	28.3	1	250	III	-
4	30.4	1	120	III	-

Notes: Based on the classification of laser coagulation spots of Lu and Noyori,<sup>2</sup> we made some slight modification and divided the injuries into four classes:

Class I: Epithelial cell changes, pigment diffusion, swelling of the rod and cone layer, loss of fibrous structure.

Class II: In addition to symptoms of class I, formation of gas bubbles in the rod and cone layer, pyenotic changes or fragmentation of outer nuclei.

Class III: In addition to symptoms of class II, partial rupture of the retina, significant nuclear pyenotosis.

Class IV: Rupture of the entire retina, hemorrhage.

## II. Discussion

1. There is generally a positive correlation<sup>4</sup> between the laser dosage and the degree of retinal injury. Based on retinal injuries observed ophthalmoscopically, the threshold dosage is a dividing line for the degree of injuries. For dosages within a certain range above or below the threshold, the injuries are similar, as shown in Tables 1 and 2. Therefore, from a pathological point of view, the threshold should not be a point but a range. Irradiations made within this range are similar. In addition, the degree of injury depends on the exposure time. In this work irradiations in Group A were made below the threshold but the exposure time was increased from 0.145 sec to 1 sec. For 0.145 sec, the injury was class I, but the injury for 1 sec was class III. Even at dosage levels well below the threshold, serious injuries can still be induced with a sufficiently long exposure time.

2. Morphological studies showed that retinal injuries at 1 hour after the irradiation had the following characteristics:

(1) Retinal injuries undergo a qualitative change from slight changes to obvious necrosis. Table 1 shows that the changes are mainly qualitative below the threshold and necrosis above the threshold. The threshold that we established on the basis of the ophthalmoscopic observations is therefore pathologically significant. Below the threshold the changes are reversible whereas retinal changes caused by above threshold radiation are irreversible.

(2) In general, after histological injuries caused by physical or chemical forces, white cell infiltration occurs as soon as 5 to 10 minutes afterwards. However, even 1 hour after the retina was irradiated by a laser, almost no material exudation was observable except occasional liquid exudation and choroid blood vessel dilation. This is true even for class III injuries. This suggests that the injuries to the retina and the blood vessel wall by the laser dosages used in our experiments are lighter than the usual physical, chemical or biological injuries. This makes the laser special in terms of retinal disease treatment. The same phenomenon has also been observed in hepatectomy and splenectomy operations using lasers.

Due to the limited number of observation cases in our study, some of the conclusions must be verified with more extensive experimental work in the future.

## REFERENCES

1. J. Jacobson, Arch. Ophthal., 1965, 74, 882.
2. J. Curtin, Amer. J. Ophthal., 1968, 65, 188.
3. Lu Xinyin, "Laser Ophthalmology," First edition, People's Hygiene Publishing Co., 1981, p 88.
4. G. Bresnich, Inryest. Ophthal., 1970, 9, 901.

9698/6091

CSO: 8111/1099

## RETINAL INJURY THRESHOLD OF RABBITS, MONKEYS IRRADIATED BY CW OR PULSED YAG LASER BEAMS

Shanghai ZHONGGUO JIGUANG [CHINESE JOURNAL OF LASERS] in Chinese Vol 12, No 10, 20 Oct 85 pp 634-635

[Article by Chu Renyuan [5969 0088 6678], Li Mengchang [2621 5492 2490], Li Leng [2621 1515], Lu Jiajua [0712 0857 5478], Fu Tiansheng [0265 1131 3932], Chen Rongjia [2621 2837 1367], and Jiang Yongming [3068 3057 2494] of the Ophthalmology Institute, Shanghai Medical University, Zhu Baoqian [2612 1405 6870], Cui Jixiu [1508 1323 4423], and Lu Zhenzhen [0712 3791 3791] of the Shanghai Institute of Optics and Fine Mechanics]

[Text] Abstract: The injury thresholds of rabbit retina by CW and pulsed YAG laser (1.06  $\mu\text{m}$ ) have been determined. The injury thresholds of monkey retina have also been studied using 150  $\mu\text{s}$  pulsed YAG laser beams. The experimental method and the results are described in this paper.

In order to obtain the retinal injury threshold of the human eye by YAG lasers with a wavelength of 1.06  $\mu\text{m}$ , we made the study reported here. The injury threshold is taken as the laser energy that causes 50 percent retinal injury. To determine the maximum allowable dosage of the YAG laser on the human eye, we first irradiated the eyes of gray rabbits and rhesus monkeys with CW and pulsed YAG laser. Using a weighted linear regression method we analyzed the data and calculated the YAG laser injury thresholds of rabbit eyes and monkey eyes and the laser energy for a 50 percent injury rate.

### I. Experimental Setup and Method

Both the CW and the pulsed YAG lasers had a single mode output. The output energy was controlled to within 5 percent. The optical path is shown in Figure 1. The laser beam passed through a beam spreader, a slit lamp, a pre-lens, and reached the eye. In designing the optical path, the established diopters of the rabbit eye and the monkey eye were used. The beam spreader and the pre-lens were chosen to focus the laser beam accurately on the retina.

The laser energy was monitored in real time. To assure a stable beam splitting ratio, we used a polarization compensation method. The accuracy of the measurement was improved by reducing the energy level variation due to polarization changes upon reflection and transmission.

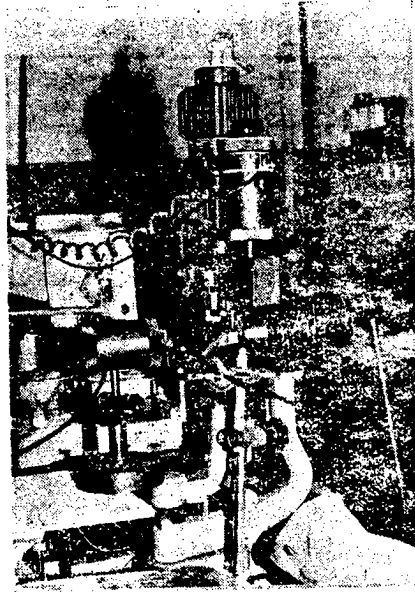
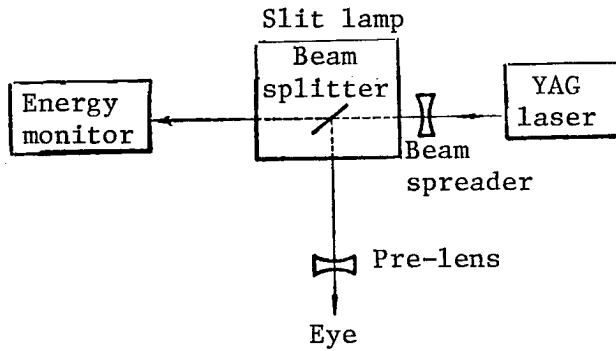

Figure 1

The light spot area was measured with a video camera and the light spot displayed on a television screen was photographed. The actual spot area was then computed from the magnification. The exposure time  $\Delta t$  was controlled by a step motor.

The transmissivity of the YAG laser light through the rabbit eye was first measured in order to calculate the actual energy level reaching the retina. To measure the transmissivity, the eyeball was removed from the rabbit and a 5 mm diameter opening was immediately cut at the rear apex of the eye. A piece of cellophane with a known transmissivity was used to cover the opening and prevent the vitreous liquid from flowing out. The incident laser energy  $E$  and the transmitted laser energy  $E'$  were then measured and the transmissivity is then equal to  $T = E/E'$ . The average measured transmissivity of the rabbit eye was 36 percent.

In measuring the retinal injury threshold for gray rabbits, three exposure times were used: 1 sec, 137 ms, and 150  $\mu$ s. Before the irradiation the pupil of the rabbit eye was dilated for 3 days with an atropine ointment.

The muscles of the rabbit were anesthetized with sodium phenobarbital. Six shots were made on each eye. The retina injuries occurred in the region below the papillary. Three observations were made after the shots: immediately after the irradiation, and 1 hour and 24 hours afterwards. The injury statistics were based on the observation made 1 hour after the irradiation and injuries appeared afterwards were not counted. Figure 2 shows the retina damage of the rabbit eye.

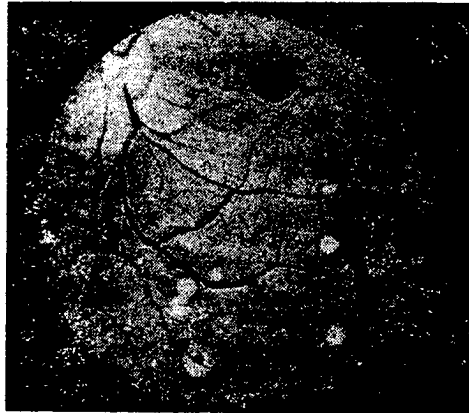

Figure 2. Ocular photograph of a laser-damaged rabbit eye

To measure the retinal injury threshold in rhesus monkeys, we used 150  $\mu$ s YAG laser pulses. The pupil was dilated with atropine and the muscles were anesthetized with copper chloramine. The irradiation spots were distributed in different quadrants. Each eye was used for several tens of days. Like the rabbit eyes, the monkey eyes were also examined three times after the irradiation.

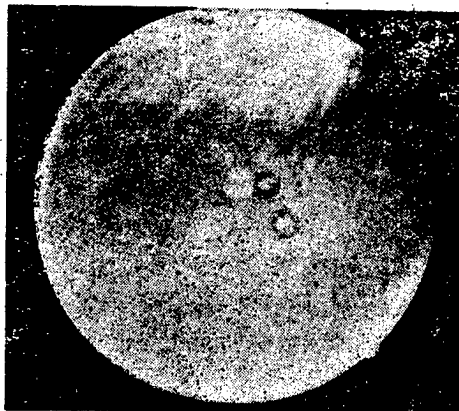

Figure 3. Ocular photograph of a laser-damaged monkey eye

## II. Experimental Results

The laser injury thresholds of the rabbit eye and the monkey eye were obtained from the statistical analysis of irradiation data in a number of animal groups at various laser energies. Different injury rates were obtained at different laser dosages. When the retina showed a 50 percent injury rate, the laser energy was taken to be the injury threshold or ED<sub>50</sub>.

A weighted linear regression calculation yielded the results listed in the following table:

Animal	Exposure time $\Delta t$	Spot area $\Delta s$ (mm <sup>2</sup> )	No of eyes	Total No of shots	Injury threshold ED <sub>50</sub> (mJ)	Energy reaching retina $E_R = E \cdot T$ (mJ)	95 percent confidence limit (mJ)	Power density $P = \frac{ED_{50}}{\Delta t \Delta s}$ (W/cm <sup>2</sup> )
Rabbit	1s	2.27	64	384	396.3	142.7	379.3~416.9	17.5
Rabbit	137 ms	2.27	86	516	208.9	75.2	174.4~250.3	67.2
Rabbit	150 $\mu$ s	1.77	40	240	0.259	0.093	0.197~0.339	97.6
Monkey	150 $\mu$ s	1.77	4	254	0.885		0.883~0.887	333.3

The trend shown by the above results is that, as the exposure time decreases, the higher the laser power, the lower the injury threshold. Under the same irradiation conditions (exposure time, laser output), the threshold of the monkey eye is greater than that of the rabbit eye and the ratio is  $E_{\text{rabbit}}:E_{\text{monkey}} = 1:3.4$ .

9698/6091

CSO: 8111/1099

## EXPERIMENTAL STUDY ON RETINAL INJURY THRESHOLD OF ANIMAL BY 694.3 nm LASER IRRADIATION

Shanghai ZHONGGUO JIGUANG [CHINESE JOURNAL OF LASERS] in Chinese Vol 12, No 10, 20 Oct 85 pp 636-637

[Article by Zhao Tongzhen [6392 2717 4176], An Xiaoyue [1344 2556 1471], Dang Zhiping [7825 3112 1627], Zhang Xiaoru [1728 1321 0320], and Guo Wenqi [6753 2429 3823] of the Xi'an Medical University Hospital No 1]

[Text] Abstract: This paper reports experimental results on retinal injury of animals by 694.3 nm irradiation. The ED<sub>50</sub> of retinal injury was obtained. The pathological characteristics of retina was observed and experimental techniques are presented.

### I. Experimental Conditions

Irradiation source: A model HJY-3 ruby laser ophthalmology unit. The pulse width was 0.7 ms, the divergence was 3 mrad, the multimode output energy was 2.5 J, and the stability was better than 3 percent.

Optical path: The optical path is shown in Figure 1. The ruby laser beam passed through a 5 mm diameter beam defining diaphragm and entered a modified slit lamp system. The beam divergence angle was 4.09 mrad. The beam was then attenuated in passing through a cup of copper sulfate solution and entered the rabbit eye. Simulation runs were made with a low power argon laser to adjust the optical path and the irradiation spot.

Real time monitoring: The stability of the beam energy was monitored by a model R<sub>j</sub> 7200 energy meter via a beam splitter. The energy entering the rabbit eye was monitored by another R<sub>j</sub> 7200 unit. The measurement errors were less than ±2 percent. The ambient temperature was 17-22°C and the relative humidity was 75-80 percent.

### II. Experiments

#### 1. Irradiation dosage and grouping

In the preliminary tests the dosage received by 100 percent and zero percent of the cornea surface are respectively 67.53 mJ/cm<sup>2</sup> and 5.23 mJ/cm<sup>2</sup>. Using the ratios of a geometric series the dosages are divided into 7 groups: 67.53, 43.31, 27.96, 17.42, 12.10, 7.64, and 5.23 mJ/cm<sup>2</sup>.

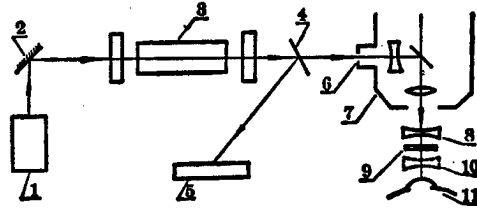

Figure 1. Optical path of the 694.3 ruby laser

1--Argon ion laser; 2--Total reflection mirror; 3--Ruby laser; 4--Beam splitter; 5--R<sub>j</sub> 7200 energy meter; 6--5 mm diameter beam defining diaphragm; 7--Slit lamp; 8--Compensating concave lens; 9--Copper sulfate solution cup; 10--Contact lens (for observation); 11--Eyeball

## 2. Animal selection and grouping

Gray chinchilla rabbits weighing 2 kg or so were examined visually and, if necessary, ophthalmoscopically. Animals with significantly different pigments were excluded. A total of 35 rabbits were used, 420 shots were made, 217 injury spots were examined, producing 1680 data points. Five rhesus monkeys were used. Due to the limited number, no grouping was made. Instead, the irradiation of the monkey retina was made using the rabbit ED<sub>50</sub> or its multiples. The reactions were examined visually and ophthalmoscopically.

## 3. Results

Immediate reactions were assessed right after the shots. Observations under an ophthalmoscope after 1 hour ranked barely visible injury spots as a positive reaction. The morphological indications of such injuries were considerably weaker than a class I coagulation spot in the treatment of laser injury. The diameter was smaller than 1 radian, the color was light gray, and the injuries were caused by pigment accumulation and uneven distribution.

## III. Experimental Results (see Tables 1 and 2)

The results on rabbits showed that the positive reaction rate increased with increasing dosage. The results on the monkeys were essentially similar.

### Data analysis:

Using a weighted regression method, we obtained the following ED<sub>50</sub> values:

For rabbit retina: ED<sub>50</sub> = 16.61 mJ/cm<sup>2</sup>, 95 percent confidence limit = 19.97-13.81 mJ/cm<sup>2</sup>.

For monkey retina: ED<sub>50</sub> = 42.53 mJ/cm<sup>2</sup>, 95 percent confidence limit = 61.17-29.56 mJ/cm<sup>2</sup>.

Table 1. Reaction of Rabbit Retina 1 Hour After 694.3 nm Ruby Laser Irradiation (parallel light)

<u>Group</u>	<u>Dose (mJ/cm<sup>2</sup>)</u>	<u>No of shots</u>	<u>No of reactions</u>	<u>Reaction rate (%)</u>
1	67.5	60	60	100
2	43.31	60	48	80
3	27.69	60	38	63.3
4	17.42	60	31	51.6
5	12.10	60	24	40
6	7.64	60	16	26.6
7	5.23	60	0	0

Table 2. Reaction of Monkey Retina 1 Hour After 694.3 nm Ruby Laser Irradiation (parallel light)

<u>Dosage (mJ/cm<sup>2</sup>)</u>	<u>No of shots</u>	<u>No of reactions</u>
16.61	6	0
16.61x1.5	6	2
16.61x2	12	5
16.61x2.5	12	6
16.61x3	12	5
16.61x3.5	6	5
16.61x4	6	6

Note: 16.61 mJ/cm<sup>2</sup> is the ED<sub>50</sub> for rabbits

#### IV. Histological and Pathological Data

After the completion of all the measurements, two rabbit eyes were irradiated with the ED<sub>50</sub> dosage for rabbits and two monkey eyes were irradiated with respectively 2 times and 2.5 times the ED<sub>50</sub> dosage for rabbits. Each eye was irradiated at six points and the usual paraffin slicing procedures were followed. Under an optical microscope the following pathological changes were found:

1. The long axis of the rabbit retina injury caused by the ED<sub>50</sub> dosage of 16.61 mJ/cm<sup>2</sup> ranged from 120 μm to 1100 μm, mostly around 500 μm. The injured retina showed bulges and edema and thickening of the rod and cone layers. Some pigment diffusion had occurred and sometimes voids had formed between the pigment layer and the rod and cone layer. The voids were filled with exudants and some detached nuclei. The pigment layer showed a reduction or diffusion of the pigments. The choroid showed neutral white cell infiltration and sometimes congestion and pigment increase.

2. For the monkey retina irradiated at 16.61 mJ/cm<sup>2</sup>, the injury length was in the 200-500 μm range and located at 1200 μm from the disk. The inner membrane bulged out, with light pink exudation at the lower part.

3. The monkey retina irradiated at a dose of twice the rabbit ED<sub>50</sub> showed considerable pyenotic nucleus, edema and thickening of the rod and cone layer, and pigment diffusion into the rod layer.

4. The monkey retina irradiated at a dosage of 2.5 times the rabbit ED<sub>50</sub> showed local pointed protrusions. The laser beam penetrated the retina and caused retinal rupture, hemorrhage, and loss of cells.

9698/6091

CSO: 8111/1099

## MEASUREMENT OF LASER SPOT DIAMETER ON RETINA, CORNEA

Shanghai ZHONGGUO JIGUANG [CHINESE JOURNAL OF LASERS] in Chinese Vol 12, No 10, 20 Oct 85 pp 637-638

[Article by Dang Zhiping [7825 3112 1627], An Xiaoyue [1344 2556 1471], and Li Yujun [2621 3768 0193] of the Laser Medicine Laboratory, Xi'an Medical University Hospital No 1, Chen Kuanlin [7115 1401 2651], Huang Xianqin [7806 6272 2953], and Zhang Hong [1728 4767] of the Xi'an No 1001 Plant]

[Text] Abstract: A method for measuring the laser spot diameter on the retina and cornea is described. The method is simple, fast, accurate, and harmless to the eye. It is an important development for basic research and clinical treatment.

After studying techniques reported in foreign journals, we have developed a "microscope eyepiece reticule method" using ordinary slit lamp.

### 1. Measurement of light spot diameter on the retina

(1) Application: When the ocular crosshair is sharply focused through the slit lamp and the contact lens, the laser beam is introduced into the eye through the slit lamp and the contact lens to measure the light spot diameter (or injury dimension) on the retina.

### (2) Procedure

a. A glass reticule plate with known graduation is placed in the eyepiece housing at the image plane of the compound objective.

b. Introduce the laser beam through the slit lamp and the contact lens into the eye.

c. Through the slit lamp objective, read the number of divisions occupied by the light spot on the reticule. Multiply by the value of one division to obtain the diameter of the magnified spot.

d. Divide the size of the magnified spot by the magnification of the objective to obtain the diameter of the light spot on the retina.

(3) Example

A 3 mm diameter 488 nm argon ion laser beam was introduced into a rabbit eye through a slit lamp and a contact lens. Looking through the eyepiece, the magnified image of the light spot occupied A divisions (A = 2) on the reticule. The length of one division B was known to be 50  $\mu\text{m}$  and the magnification of the objective was 1.6. Hence, the light spot diameter is

$$d = \frac{A \times B}{K_{\text{obj}}} = \frac{2 \times 50}{1.6} \approx 62 (\mu\text{m})$$

2. Measurement of the light spot diameter on the cornea

(1) A glass reticule with a graduation size B of 41  $\mu\text{m}$  was placed at the image plane of the compound objective.

(2) A vernier scale was placed at the original cornea location (13.58 mm from the pre-lens). The magnified image of a 1 mm object occupied A divisions on the reticule (A = 30). The magnified image of 1 mm was therefore  $30 \times 41 = 1230 \mu\text{m}$ .

(3) The objective has a magnification of

$$K_{\text{obj}} = \frac{1230}{1000} = 1.23$$

(4) The 3 mm diameter 488 nm argon ion laser beam was introduced onto the vernier scale through the slit lamp and the pre-lens. Through the eyepiece, the magnified image of the light spot occupied 25 divisions. The magnified image was therefore  $25 \times 41 = 1025 \mu\text{m}$ .

(5) The light spot diameter on the cornea is therefore

$$d = \frac{A \times B}{K_{\text{obj}}} = \frac{25 \times 41}{1.23} = 833 \mu\text{m}$$

9698/6091

CSO: 8111/1099

## MEASUREMENT OF TRANSMISSIVITY OF ARGON LASER LIGHT THROUGH RABBIT'S EYES

Shanghai ZHONGGUO JIGUANG [CHINESE JOURNAL OF LASERS] in Chinese Vol 12, No 10, 20 Oct 85 pp 638-639

[Article by Li Yujun [2621 3768], Dang Zhiping [7825 3112 1627], and Zhao Tongzhen [6392 2717 4176] of the Laser Laboratory, Xi'an Medical University Hospital No 1]

[Text] Abstract: The measurement of transmissivity of 488 nm argon laser light through refractive system of the rabbit's eyes in vitro is reported.

In order to measure the retinal injury threshold (ED<sub>50</sub>) of an argon laser, we measured the transmissivity of a rabbit eye to 488 nm argon laser light by introducing an opening on the sclera of a rabbit eye in vitro. The ED<sub>50</sub> value was then computed from the transmissivity and the light spot diameter on the retina.

The transmissivity of the human eye is similar to that of other mammals (rabbits, cats, monkeys, and cows). The measured transmissivity of the rabbit eye is therefore useful in research and in clinical treatment of eye diseases.

### I. Measurement Method

The 488 nm laser beam from an argon laser passes through a slit lamp and the measurements are made after the slit lamp, see Figure 1.

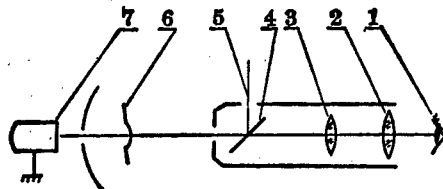

Figure 1. Optical path used in measuring the transmissivity of the rabbit eye

1--Observer's eye; 2--Eyepiece; 3--Objective; 4--45° reflection mirror; 5--Laser beam; 6--Rabbit eye; 7--Laser power meter (2, 3 and 4 constitute the slit lamp system)

The laser output was stable to within 2 percent. Using an alternation method, we repeatedly measured the laser power before the eyeball and after the eyeball. At least three measurements were made on a given eyeball at different energy levels and the average was then taken. A total of four eyeballs were used.

In order for the entire laser beam to enter the eyeball, pass through the medium and detected by the power meter, the pupil was sufficiently dilated. After the eyeball was removed from the body, a 3 mm diameter small hole was opened immediately on the sclera so that the laser may exit freely.

## II. Results and Analysis

For a hole opened below the disk the transmissivity is 90.1 percent. For a hole opened at the disk the transmissivity is 94.1 percent. The table below lists the measurement data.

Table 1. Measurement Data

Eye-ball No.	Sclera location	Laser power (mW)	Laser power after passing through the eyeball (mW)	Transmissivity (%)	Ave. transmissivity (%)	
1	On the retina, below the disk	16.4	14.8	90.4	90.2	90.1
		21.6	19.5	90.5		
		33.0	29.1	88.3		
		38.2	34.9	91.4		
2	"	18.5	16.3	88.3	88.6	
		28.2	25.2	89.5		
		38.1	33.3	87.3		
3	"	16.5	15.1	91.8	91.5	
		24.0	22.0	91.8		
		40.0	36.4	91.0		
4	At the disk	17.0	15.9	93.6	94.1	
		25.5	21.4	94.5		
		40.5	38.1	94.1		

The results in the table show that:

1. For a given eyeball, the transmissivity obtained with different laser energy varied slightly. These are measurement errors.
2. For the same laser energy, the transmissivity of different eyeballs varied slightly. These are due to differences in the eyeballs and due to misalignment of the axis.
3. The transmissivity is more sensitive to the location where the laser passes through the eye. The transmissivity is higher when the laser passes

through the visual disk. This can be attributed to two reasons: First, variations of the sclera opening and the axis lead to different optical paths in the eye and hence a different transmissivity. Second, the opening of the hole caused some loss of the vitreous liquid and hence affected the transmissivity.

It has been reported that the medium of a rabbit eye absorbs 10 percent of the argon laser energy, that is, the transmissivity of the rabbit eye to the argon laser is 90 percent. Our results are in agreement with this and can be trusted.

9698/6091

CSO: 8111/1099

INJURY THRESHOLD OF SKIN IRRADIATED WITH 308 nm EXCIMER LASER LIGHT STUDIED

Shanghai ZHONGGUO JIGUANG [CHINESE JOURNAL OF LASERS] in Chinese Vol 12, No 12, 20 Dec 85 pp 735-738

[Article by Li Zhaozhang [2621 0340 3864], Wu Jianu [0702 1367 1166], and Gai Baokang [5556 1405 1660] of the Laser Medicine Laboratory, Shanghai No. 2 Medical University, and Zhou Zhengzhuo [0719 2398 0587] of the Shanghai Institute of Laser Technology]

[Text] Abstract: The paper reports the preliminary results of ultraviolet erythema on the skin irradiated with 308 nm excimer laser light. Using white pigs as an animal model, we obtained injury threshold data of the skin. The 95 percent confidence limit of MRD<sub>50</sub>, an energy density that results in 50 percent perceptible redness occurrence rate for all points irradiated ranges from 45.97 to 63.05 mJ/cm<sup>2</sup>.

The biological study of irradiating the skin with ultraviolet light began at the turn of the century. The Danish physicist Niels Finsen first treated lupus with an artificial UV source. Hausser and Vahle of West Germany investigated the effect UV of various wavelengths on the human skin using a low pressure mercury lamp and a double quartz prism monochromatic light source and found that irradiation at 300 nm tended to cause erythema. In the 1930's Coblentz et al measured the UV induced erythema and found that wavelengths from 200-280 nm could cause noticeable transient erythema and wavelengths of 254 nm and 197 nm were most likely to produce retaining erythema. In 1965 Everett and coworkers measured the erythema curve of the human skin with a Xenon arc monochromatic source equipped with a grating. They found that, as the UV wavelengths increased, the energy required to produce minimum erythema also increased. For wavelengths longer than 300 nm, the erythema effect was considerably reduced. In the 1970's Parrish irradiated the Caucasian skin with a nitrogen laser and found that the minimum dosage of a multipulse N<sub>2</sub> laser for producing lasting erythema was 2.6±4.8 J/cm<sup>2</sup>. Aufmuth reported in 1979 the effects of a dye laser (tunable from 260 to 345 nm) on the human skin and found that the MRD (minimum redness dosage) of a 300 nm UV laser was 5 mJ/cm<sup>2</sup>. In recent years Anderson and Parrish studied the effects of short pulse UV lasers on the human skin and found that the photochemical reaction played an important role.

The skin injury threshold by a 308 nm excimer laser has not been reported in China or abroad. Work in this area is really needed in order to establish a laser protection standard in China.

## I. Experimental Material and Method

An XeCl excimer laser was used as the irradiation source. The wavelength was 308 nm, the pulse width was 15 ns, the maximum output energy per pulse was 100 mJ, the divergence angle was 12.8 mrad along the major axis direction and 7.1 mrad along the minor axis.

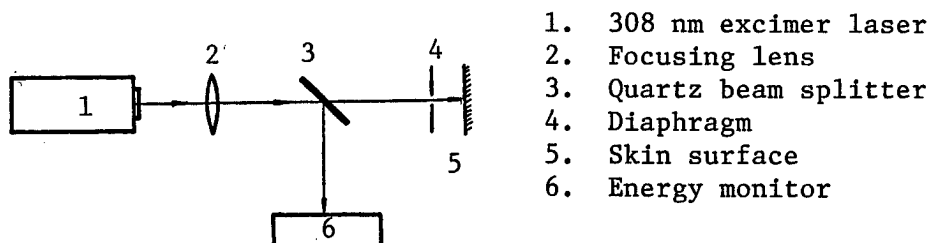

Fig. 1. Schematic diagram of the experimental setup

Figure 1 shows the experimental setup. The dosage was determined by monitoring the energy and the beam splitting ratio ( $K = 2.1 \pm 0.087$ ). The calibration of the energy meter used can be traced to the State Institute of Measurement. The ambient conditions were  $25^\circ\text{C} \pm 1.1^\circ\text{C}$  and  $79.3 \pm 8.4$  percent humidity.

The experimental animals were three 5.5 kg Shanghai White pig. Two hours before the irradiation, the animals were put under anaesthesia by injecting 1 ml per kilogram of body weight of 2.5 percent sodium isobarbiturate. The pig was then washed with warm water and soap. The back and abdomen of the animal were shaved clean. From the two sides of the spine to the abdomen, 40 2cm x 2cm grids were painted on the skin. The laser beam was then trained to the center of the squares after passing through a 5 mm diameter diaphragm.

The observation of the erythema was done mainly with the unaided eyes. The criteria for judging the erythema will not be discussed here. The injury threshold in this experiment was based on the "+" grade erythema. The dosage for 50 percent "+" erythema occurrence within 24 hours after the irradiation was measured. Optical microscopic examinations were made at different time intervals after the irradiation of the 7 groups. Electron microscopic inspections were also made for the near threshold runs.

A total of 230 shots were made in the course of the experiment, 18 of them were examined histologically. The 212 data points in the 7 irradiation dosage groups were subjected to statistical analysis. Using a weighted regression method (performed on a PDP11-23 computer), the  $\text{MRD}_{50}$  value and the 95 percent confidence level for the white pig skin irradiated by a 308 nm excimer laser were obtained.

Table 1. Transient erythema reaction of the pig skin irradiated by a 308 nm excimer laser

Group	Ave. dose ± std. dev. (mJ/cm <sup>2</sup> )	No. of shots	Transient erythema			Redness indica- tion
			Rate %	Occurrence time (sec. after the shot)	Lasting time (min, sec)	
1	22.28±2.26	32	—	—	—	—
2	29.44±1.80	32	—	—	—	—
3	39.76±3.85	30	33.33	9"~18"	49"~2'17"	±
4	53.56±5.19	31	41.94	7"~12"	1'28"~2'26"	±
5	69.14±4.51	27	70.37	4"~13"	1'54"~5'	+
6	91.27±1.96	30	83.33	5"~15"	45"~8'42"	+
7	106.17±3.18	30	100.00	instant- ly to 15"	39"~10'	++-

Table 2. Delayed erythema reaction of the pig skin irradiated by a 308 nm excimer laser

Group	Ave. dose ± std. dev. (mJ/cm <sup>2</sup> )	No. of shots	No. of red spots after 24 hours	Delayed ery- thema occur- rence rate(%)	Redness indication
1	22.38±2.26	32	5	15.63	±
2	29.44±1.80	32	9	28.13	±
3	39.76±3.85	30	11	36.67	±+
4	53.56±5.19	31	14	45.16	+
5	69.14±4.51	27	15	55.56	++-
6	91.27±1.96	30	22	73.33	++
7	106.17±3.18	30	25	83.33	+++

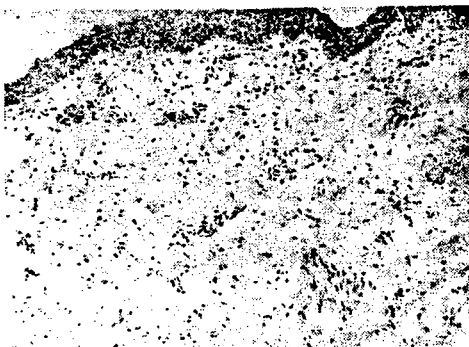

(a) Histological examination of Group 4 with H.E. stain made 24 hours after the laser shot showing dilation and congestion of the blood capillaries in the dermis.

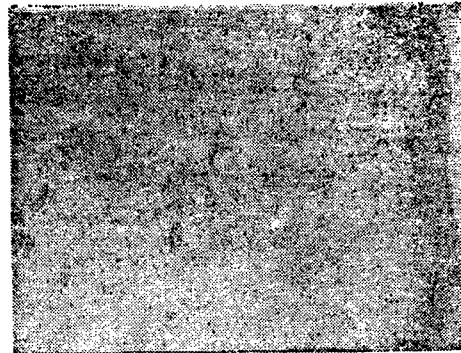

(b) Histological examination of Group 5 with H.E. stain made 24 hours after the laser shot showing dilation and congestion of the blood capillaries in the dermis.

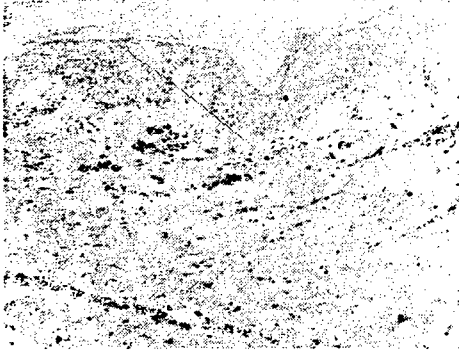

(c) Histological examination of Group 6 with H.E. stain made 24 hours after the laser shot showing dilation and congestion of the blood capillaries in the dermis and edema of the cuticular cells

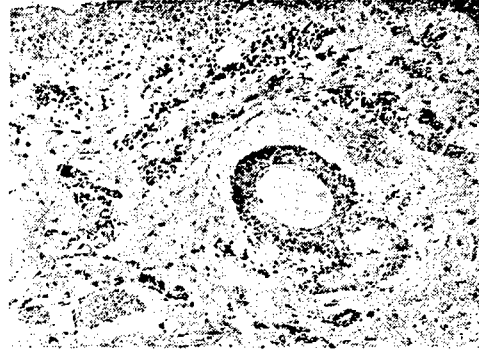

(d) Histological examination of Group 7 with H.E. stain made 24 hours after the laser shot showing dilation and congestion of the blood capillaries in the dermis, accumulation of infectious cells, and edema of the cuticular cells



(e) Specimen taken 5 minutes after the laser shot at a dosage of  $53.56 \pm 5.19 \text{ mJ/cm}^2$  showing an increased prickle cell spacing. (x11,200 by electron microscope)



(f) Specimen taken 5 minutes after the laser shot at a dosage of  $69.14 \pm 4.51 \text{ mJ/cm}^2$  showing an increased prickle cell spacing. (x11,200 by electron microscope)

## II. Experimental Results and Analysis

Table 1 and Table 2 show the transient and delayed erythema reaction of the pig skin irradiated with 308 nm laser light. Delayed erythema usually appeared 8-9 hours after the shots, although in Groups 6 and 7 the erythema appeared after only 5 hours. The number of erythema in all groups reached a maximum at 24 hours and the color also became the darkest. The redness usually lasted for 2-3 days. The delayed erythema in Group 6 had all become pigment precipitates after 48 hours delayed erythema in Group 7 formed scabs.

Histological examinations made after 24 hours of the skin irradiated at different dosage were: Group 1 showed no observable reactions, Groups 2 through 4 showed various degrees of capillary dilation and congestion in the dermis together with some red blood cell exudation, Group 5 showed the same reactions as Groups 2-4 and also the appearance of lymphocytes around the blood vessels, Group 6 showed groups of infectious cells in the dermis, and Group 7 showed basal cell edema accompanied by some cavities and rarification of the cells. Photomicrographs a-d show the detailed changed. Optical and electron micrographs (e,f) showed basically normal structure of the transient erythema skin in Groups 3-5.

The MRD<sub>50</sub> value and the 95 percent confidence limit of the irradiated pig skin by the 308 nm laser light were obtained from visual observation and weighted regression. The results are shown in Table 3 and Fig. 2. Here x is the logarithm of the laser dosage, y is the delayed erythema occurrence probability, and a  $\chi^2$  test of the regression formula showed satisfactory results.

Table 3. Probability analysis of the pig skin injury threshold by 308 nm laser radiation

	Visual observation	Weighted regression
Regression equation		$y=0.4759 + 2.6134x$
MRD <sub>50</sub> (mJ/cm <sup>2</sup> )	53.09	53.84
95% confidence limit (mJ/cm <sup>2</sup> )	43.36-65.00	45.97-63.05

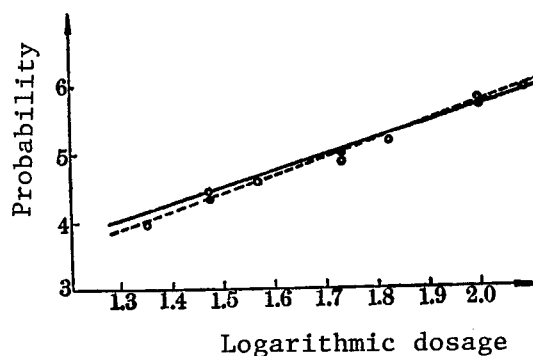

Fig. 2. Erythema occurrence probability as a function of the logarithmic dosage. Solid line -- visual observation, dashed line -- weighted regression. o -- experimental value, ● -- computed by weighted regression.

### III. Discussion

#### 1. Two-phase erythema reaction caused by short ultraviolet laser pulse

The two phases of the skin erythema reaction caused by ultraviolet radiation--transient and delayed--were clearly observed in our experiments. The transient erythema caused by the 308 nm laser radiation occurred quickly and disappeared quickly--lasting no more than 15 minutes. This phenomenon may be due to the pressure effect of the short ultraviolet laser. When the pressure reached a certain critical value, the transport of the blood cell was changed and resulted in transient erythema. Delayed erythema occurred after a delay period, characteristic of photochemical reactions. It was reported in foreign journals that photochemical reactions may produce histamine, 5-hydroxylamin, activated peptide, and prostaglandin E, F, and G, which in turn caused the delayed reaction. Biochemical studies are needed to further understand the generation mechanism of skin erythema by ultraviolet radiation.

#### 2. Minimum redness dosage (MRD) and laser protection standard

In our experiments we used pigs as an animal model and obtained  $53.84 \text{ mJ/cm}^2$  as the injury threshold  $\text{MRD}_{50}$  for the short ultraviolet laser pulses. At this dosage, 50 percent of the irradiated points showed barely visible redness. Similarly, the 10 percent dosage ( $\text{MRD}_{10}$ ) was obtained from the regression equation to be  $6.91 \text{ mJ/cm}^2$ . Compared to current international laser safety standards (IEC, ANSI, WHO environmental health standard 23, etc), the ratio of the maximum permissible dosage  $6.19 \text{ mJ/cm}^2$  for a 308 nm short laser pulse on the skin and the MPE value is only 1.1. This means that the boundary between safety and possible injury is not clearout. One must therefore take proper precaution in consulting the existing maximum permissible dosage when ultrashort ultraviolet laser pulses are used.

9698/7358

CSO: 8111/1421

LASER SAFETY, PROTECTION STANDARDS REVIEWED

Shanghai YINGYONG JIGUANG [APPLIED LASER] in Chinese, Vol 6, No 3, Jun 86  
pp 141-144

[Article by Li Zhaozhang [2621 0340 3864] of the Shanghai Second Medical University, Division of Laser Medicine: "Review of the Studies on Laser Safety and Production Standards"]

[Text] Abstract: The recent development of laser safety studies in China is reviewed. Based on the analysis and comparison of the biological data in China and abroad, and in terms of international advanced laser safety standards, some essential factors are briefly discussed for setting the Chinese Safety Standard of Laser Radiation.

Laser technology has found increasingly wide uses in China's industry, agriculture, medicine, technology and defense and the number of people involved in the use of lasers is increasing rapidly. The laser safety and protection issue has been placed on the agenda to carry out the preventive policy of protecting the environment and the welfare of the people.

Based on technical information from abroad, all developed nations have organized special efforts to research and formulate laser safety and protection standards. Such standards have also been revised repeatedly as laser technology development and research progress. Today, the U.S., the U.K., West Germany, the U.S.S.R., Canada, Sweden, France, Denmark, and Austria have established the respective national standards and regulations. In addition, we have learned that Japan is also working hard on laser safety research. China is one of the first countries engaged in laser applications and, as a major nation, cannot do without its own laser safety standards that are applicable to the physiological characteristics of the yellow race.

From 1982 to 1985 the Chinese State Science and Technology Commission organized a national laser protection standard research group and conducted experiments for 3 years. Based on the experience of laser safety research conducted abroad and surveys of laser usage in China, the group conducted eye and skin damage threshold experiments using eight commonly used laser at eleven wavelengths.

Probability statistical analysis methods are used internally in the evaluation of laser damages. The damage threshold is usually defined as the laser radiation dosage corresponding to a 50 percent probability for detecting the minimum damage visually. The damage threshold for the eye and the skin are respectively denoted as ED<sub>50</sub> and MRD<sub>50</sub>. Since the measurement of the laser damage thresholds is a delicate quantitative endeavor, the various units in the research group have set stringent criteria on experimental apparatus including lasers and optical systems and on the measurement of dosages, data processing, and biological observations to insure reliability of the results. The criteria are:

- (1) Laser source--Continuous outputs are desired from single mode lasers, pulsed outputs must have a stability better than  $\pm 5$  percent.
- (2) The equipments used for dosage measurements must be periodically calibrated by the State Measurement Institute.
- (3) All biological reactions must be examined histologically with optical or electron microscopes.
- (4) Weighted regression analysis should be used in data processing so that the results may be compared with those from abroad.
- (5) Experiments for each wavelength should be conducted by at least two units to ensure accuracy.

For the damage threshold of the eye, the research group used rabbits and monkeys, whose eyes closely resemble those of humans, as animal models and irradiation was conducted at eight different laser wavelengths. The E<sub>50</sub> data obtained are listed in Table 1.

For the study of the skin damage threshold, small white pigs were used as the animal model. Eight laser wavelengths were used for irradiation of various time durations. Table 2 shows the MRD<sub>50</sub> value obtained for the skin.

The research results listed above served as the biological data base for establishing China's laser safety and protection standards. One hundred twenty volunteers of the yellow race participated in the skin damage threshold tests conducted at five laser wavelengths. The number of human subjects exceeded that of similar research in foreign countries. The damage threshold of the eye by 222 nm and 308 nm ultraviolet lasers and the skin damage threshold by 265 nm (quadruple frequency YAG laser) and 308 nm ultraviolet laser are original results not previously reported in China or abroad. Such data have helped the formulation of safety standards for ultraviolet lasers.

Table 1. ED<sub>50</sub> of laser damage of the eye

Wavelength (nm)	Subject*	Irradiation time(s)	Spot dia. cornea (mm)	Incident energy or power density (J/cm <sup>2</sup> or w/cm <sup>2</sup> )	Remarks
222	1	8 × 10 <sup>-9</sup>	1	54.4 × 10 <sup>-3</sup> J/cm <sup>2</sup>	Cornea damage
308	1	8—10 × 10 <sup>-9</sup>	1	0.83 J/cm <sup>2</sup>	
488	1	1 × 10 <sup>-1</sup>	2.76	0.51 w/cm <sup>2</sup>	Retina damage threshold
488	1	1.45 × 10 <sup>-1</sup>	3	0.50 w/cm <sup>2</sup>	
488	1	1	2.76	0.43 w/cm <sup>2</sup>	
488	1	1	3	0.40 w/cm <sup>2</sup>	
488	2	1 × 10 <sup>-1</sup>	2.76	0.834 w/cm <sup>2</sup>	
488	2	1.45 × 10 <sup>-1</sup>	3	1.8 w/cm <sup>2</sup>	
488	3	1 × 10 <sup>-1</sup>	2.76	1.76 w/cm <sup>2</sup>	
488	3	1.45 × 10 <sup>-1</sup>	0.833	17.65 w/cm <sup>2</sup>	
530	1	5 × 10 <sup>-9</sup>	5	39.2 × 10 <sup>-6</sup> J/cm <sup>2</sup>	
530	1	8 × 10 <sup>-9</sup>	4	232.1 × 10 <sup>-6</sup> J/cm <sup>2</sup>	
530	2	5 × 10 <sup>-9</sup>	5	187 × 10 <sup>-6</sup> J/cm <sup>2</sup>	
632.8	1	1	4.3	178 × 10 <sup>-3</sup> w/cm <sup>2</sup>	
632.8	1	1.25 × 10 <sup>-1</sup>	4.3	215 × 10 <sup>-3</sup> w/cm <sup>2</sup>	
694.3	1	6 × 10 <sup>-4</sup>	5	14.9 × 10 <sup>-3</sup> J/cm <sup>2</sup>	
694.3	1	7 × 10 <sup>-4</sup>	5	16.6 × 10 <sup>-3</sup> J/cm <sup>2</sup>	
694.3	2	7 × 10 <sup>-4</sup>	5	42.5 × 10 <sup>-3</sup> J/cm <sup>2</sup>	
1060	1	5 × 10 <sup>-9</sup>	5	1.2 × 10 <sup>-3</sup> J/cm <sup>2</sup>	
1060	1	1.5 × 10 <sup>-4</sup>	1.5	97.6 w/cm <sup>2</sup>	
1060	1	1.2 × 10 <sup>-1</sup>	5	5.4 w/cm <sup>2</sup>	
1060	1	1.37 × 10 <sup>-1</sup>	1.7	67.2 w/cm <sup>2</sup>	
1060	1	1	1.7	17.5 w/cm <sup>2</sup>	
1060	1	1.02	5	2.5 w/cm <sup>2</sup>	
1060	2	1.5 × 10 <sup>-4</sup>	1.5	333.3 w/cm <sup>2</sup>	
1060	2	5 × 10 <sup>-9</sup>	5	4.3 × 10 <sup>-3</sup> J/cm <sup>2</sup>	
1060	3	1.5 × 10 <sup>-4</sup>	1.75	429 w/cm <sup>2</sup>	
10600	1	1.2 × 10 <sup>-1</sup>	1	10.7 w/cm <sup>2</sup>	Cornea damage
10600	1	1.25 × 10 <sup>-1</sup>	1	4.0 w/cm <sup>2</sup>	
10600	1	1	1	3.6 w/cm <sup>2</sup>	
10600	1	1.03	1	5.7 w/cm <sup>2</sup>	

\* 1. Rabbit      2. Monkey      3. Eye of yellow race

Table 2. MRD<sub>50</sub> for laser damage of the skin

Laser wavelength λ (nm)	Subject	Exposure time (s)	MRD <sub>50</sub> (J/cm <sup>2</sup> )	λ (nm)	Subject	Exposure time (s)	MRD <sub>50</sub> (J/cm <sup>2</sup> )
10600	white pig	1	3.7	694.3	white pig	3.2×10 <sup>-4</sup>	53.3
10600	white pig	1	2.4	694.3	human, yellow race	3.2×10 <sup>-4</sup>	4.7
10600	human, yellow race	1	2.7	514.5	human, yellow race	1	7.1
10600	human, yellow race	1	2.3	488	grey pig	1	5.2
1060	white pig	1	59.4	488	human, yellow race	1	5.6
1060	white pig	2×10 <sup>-4</sup>	4.6	488	human, yellow race	1	5.6
1060	human, yellow race	1	60.6	37.1	white pig	4.5×10 <sup>-9</sup>	8.3
1060	human, yellow race	1	71.4	308	white pig	15×10 <sup>-9</sup>	53.8×10 <sup>-3</sup>
1060	human, yellow race	2×10 <sup>-4</sup>	9.9	308	white pig	50-70×10 <sup>-9</sup>	73.0×10 <sup>-3</sup>
1060	human, yellow race	3×10 <sup>-4</sup>	20.3	265	white pig	9×10 <sup>-9</sup>	22.0×10 <sup>-3</sup>

The eye and skin damage thresholds are criteria for evaluating safe laser dosages. The national laser safety standard research group has carefully studied the entire results. Based on health statistics procedures and using probability equations, the values of ED<sub>10</sub> and MRD<sub>10</sub> (10 percent probability for minimum damages) have been computed and compared to ED<sub>50</sub> and MRD<sub>50</sub>.

$$ED_{50} : ED_{10} = 1.2-2.2 : 1$$

$$MRD_{50} : MRD_{10} = 1.23-3.1 : 1$$

Both ratios are greater than unity. Therefore, a safety factor of 5-20 may be used in computing the maximum permissible exposure (MPE) or exposure limit (EL) from ED<sub>50</sub> or MRD<sub>50</sub>. Since most of experimental data are obtained from animal tests, the safety factor should be on the high side when MPE is computed from ED<sub>50</sub>.

In comparison with similar studies made abroad, the MRD<sub>50</sub> for the Chinese falls between that for Caucasians and blacks, see Table 3. The ED<sub>50</sub> for rabbit and monkey eyes in the Chinese studies is somewhat higher, but their dependence on the exposure time is consistent with the foreign data. We can therefore use the laser safety standards of advanced nations as references in formulate China's own standards.

Table 3. Comparing the MRD<sub>50</sub> for Chinese with foreign study results

Laser	$\lambda$ (nm)	Exposure time (s)	Subject	MRD <sub>50</sub> (J/cm <sup>2</sup> )	EL(J/cm <sup>2</sup> )	MRD <sub>50</sub> (min)/EL	
Ruby laser	694.3	$2.5 \times 10^{-3}$ $0.32 \times 10^{-3}$	White	11-20	0.25	44	
			Black	2.2-6.9		9	
			Chinese	4.2-5.1		0.147	28
Nd:glass laser	1060	$75 \times 10^{-9}$ $2 \times 10^{-4}$ $3 \times 10^{-4}$	White	4.2-5.7	0.1	42	
			Black	2.5-3.0		25	
			Chinese	9.3-10.6		0.65	14
			Chinese	19.0-21.9		0.72	26
CO <sub>2</sub>	10600	1.0	White	2.8	0.56	5	
			Black	2.8		5	
			Chinese	2.3-2.7		4	
Nd:YAG	1060	1.0	White	48-78	5.5	9	
			Black	46-60		8	
			Chinese	60-71		11	
Ar <sup>+</sup>	488.0	1.0	White	4.0-8.2	1.1	4	
			Black	4.5-6.0		4	
			Chinese	5.6-5.64		5	

In order to establish China's laser safety and protection standards, the national research group has not only completed the biological tests described above, but have also collected extensive data in China and from abroad and translated and compiled important international laser safety standards including the IEC standard on laser product specification, the World Health Organization environmental health standard 23, and the ANSI standard Z136-1 1980 on the safe use of lasers. The group has also interviewed laser workers in Beijing, Shanghai, Tianjin, Xi'an, Henan, and in northeastern China to assess the causes for laser accidents and the physical examination of laser workers. By combining the experimental research results, the international data, and the survey results, the national laser safety and protection research group consulted dozens of laser production and research units and formulated the proposal on laser standards after several modifications.

Today there are more than 300 laser research and production units in China and many laser medical units. The number of workers involved with the usage of lasers exceeds 10,000. The establishment of the laser safety and protection standards is therefore very important to the safety of the workers.

#### REFERENCES

1. D.H. Sliney et al; Safety with Lasers and Other Sources, a Comprehensive Handbook, 1980 Plenum Press.
2. A. Mallow et al; Laser Safety Handbook, 1978.
3. American National Standard for the Safe Use of Lasers. ANSI Z 136.1, 1980.
4. Lasers and Optical Radiation from WHO 1982, Environmental Health Criteria 23
5. R.J. Rockwell et al; AD A 012/703, 1974
6. Radiation Safety of Laser Products Equipment Classification, Requirements, and User's Guide. International Electrotechnique Commission, April 1980
7. ZHONGGUO JIGUANG [CHINESE JOURNAL OF LASERS], Vol 12, No 10, 1985; Vol 12, No 12, pp 732-741, 1985.

9698/7358

CSO: 4008/88

END