

254082

JPRS-CST-86-029

24 JULY 1986

# China Report

SCIENCE AND TECHNOLOGY

19981021 117

DUPLICATE DESTROYED

DISTRIBUTION STATEMENT B

Approved for public release;  
Distribution Unlimited

**FBIS**

**FOREIGN BROADCAST INFORMATION SERVICE**

REPRODUCED BY  
NATIONAL TECHNICAL  
INFORMATION SERVICE  
U.S. DEPARTMENT OF COMMERCE  
SPRINGFIELD, VA. 22161

37  
102  
A06

#### NOTE

JPRS publications contain information primarily from foreign newspapers, periodicals and books, but also from news agency transmissions and broadcasts. Materials from foreign-language sources are translated; those from English-language sources are transcribed or reprinted, with the original phrasing and other characteristics retained.

Headlines, editorial reports, and material enclosed in brackets [] are supplied by JPRS. Processing indicators such as [Text] or [Excerpt] in the first line of each item, or following the last line of a brief, indicate how the original information was processed. Where no processing indicator is given, the information was summarized or extracted.

Unfamiliar names rendered phonetically or transliterated are enclosed in parentheses. Words or names preceded by a question mark and enclosed in parentheses were not clear in the original but have been supplied as appropriate in context. Other unattributed parenthetical notes within the body of an item originate with the source. Times within items are as given by source.

The contents of this publication in no way represent the policies, views or attitudes of the U.S. Government.

#### PROCUREMENT OF PUBLICATIONS

JPRS publications may be ordered from the National Technical Information Service, Springfield, Virginia 22161. In ordering, it is recommended that the JPRS number, title, date and author, if applicable, of publication be cited.

Current JPRS publications are announced in Government Reports Announcements issued semi-monthly by the National Technical Information Service, and are listed in the Monthly Catalog of U.S. Government Publications issued by the Superintendent of Documents, U.S. Government Printing Office, Washington, D.C. 20402.

Correspondence pertaining to matters other than procurement may be addressed to Joint Publications Research Service, 1000 North Glebe Road, Arlington, Virginia 22201.

24 JULY 1986

CHINA REPORT  
SCIENCE AND TECHNOLOGY

CONTENTS

PEOPLE'S REPUBLIC OF CHINA

NATIONAL DEVELOPMENTS

Trends in S&T Technology Imports Detailed (Yan Huimin; GUOJI SHANGBAO, 24 Apr 86) .....	1
Fujian Imports Optical Fiber Equipment From Italy (Chen Huibo; FUJIAN RIBAO, 26 May 86) .....	3
Chemical Industry Needs Imported Technology (XINHUA, 1 Jun 86) .....	4
Shanghai Urged To Stress Production for Export (XINHUA, 22 Jun 86) .....	5
Electronics Industry Minister Views Developments (Liu Sa; GUANGMING RIBAO, 24 Jan 86) .....	7
China's First Robot Research Center Being Built in Shenyang (XINHUA, 31 Jan 86) .....	10
UN Space Committee Reaches Consensus on Remote Sensing Accord (XINHUA, 14 Jun 86) .....	12
Defense Industry Modernization Progress Discussed (RENMIN RIBAO OVERSEAS EDITION, 11 May 86) .....	14
Beijing Plays Host to Aerodynamics Conference (XINHUA, 23 Jun 86) .....	16

Municipal Regulations on Radiation Protection Becomes Effective (Beijing City Service, 23 Apr 86) .....	17
Chinese, Japanese Scientists To Study 'Kuroshio' Current (XINHUA, 21 May 86) .....	18
Computer Use, Technology on Rise in PRC Projects (Nie Lisheng; CHINA DAILY, 4 Jun 86) .....	19
Inventors Donate Multi-Language Computer Systems (XINHUA, 23 Jun 86) .....	21
Computerization Planned for Enterprises (XINHUA, 24 Jun 86; CHINA DAILY, 25 Jun 86) .....	22
Two Industries To Test Plan	22
Official Discusses Strategy, by Nie Lisheng	23
Technology Contract Law Discussed (Wang Kejian; KEXUEXUE YU KEXUE JISHU GUANLI, No 10, 12 Oct 85) .....	24
Shanghai Advances in Technological Development (Shen Shiwei, Wu Mingfei; XINHUA Domestic Service, 17 Jun 86) .....	27
Dow Transfers Technology to Yanshan Plant (XINHUA, 18 Jun 86) .....	28
Foreign S&T Cooperation, Legal Protections Discussed (Yang Peilin; KEXUEXUE YU KEXUE JISHU GUANLI, No 10, 12 Oct 85) .....	29
Seminar on Medical Imaging Technology Opens (XINHUA, 18 Jun 86) .....	32
Public Health Vice-Minister on Traditional Medicine (XINHUA, 14 May 86) .....	33
Number of Private Doctors, Dentists Increases (CHINA DAILY, 11 Jun 86) .....	34
Development Strategy for Tianjin's Colleges Discussed (Zeng Di; KEXUEXUE YU KEXUE JISHU GUANLI, No 10, 12 Oct 85)	35
<b>Briefs</b>	
Guizhou Organic Geochemistry Workshop	41
Control-System Software Package Developed	41
State Council Limits Integrated Circuit Imports	42
Journalists Establish Environmental Forum	42
Largest Radio Telescope	42
Yueli Chairman of Pharmacopoeia Committee	42

ABSTRACTS

APPLIED ACOUSTICS

YINGYONG SHENGXUE [APPLIED ACOUSTICS], No 2, Apr 86 ..... 43

APPLIED LASERS

YINGYONG JIGUANG [APPLIED LASER], No 2, Apr 86 ..... 47

ASTRONOMY

TIANWEN XUEBAO [ACTA ASTRONOMICA SINICA], No 1, Mar 86 ..... 52

CHEMISTRY

HUAXUE XUEBAO [ACTA CHIMICA SINICA], No 12, Dec 85 ..... 54

ELECTRONICS

DIANZI XUEBAO [ACTA ELECTRONICA SINICA], No 6, Nov 85 ..... 57

OPTICS

GUANGXUE XUEBAO [ACTA OPTICA SINICA], No 4, Apr 86 ..... 65

PHYSICS

WULI [PHYSICS], No 1, Jan 86 ..... 72

WULI [PHYSICS], No 2, Feb 86 ..... 74

WULI XUEBAO [ACTA PHYSICA SINICA], No 3, Mar 86 ..... 77

WULI XUEBAO [ACTA PHYSICS SINICA], No 4, Apr 86 ..... 84

GAONENG WULI YU HE WULI [PHYSICA ENERGIAE FORTIS ET PHYSICA  
NUCLEARIS], No 3, May 86 ..... 91

/7310

NATIONAL DEVELOPMENTS

TRENDS IN S&T TECHNOLOGY IMPORTS DETAILED

Beijing GUOJI SHANGBAO in Chinese 24 April 86 p 1

[Report by Yan Huimin [7346 1979 3046]: "Four New Changes in China's Technology Imports"]

[Text] There has been great development in China's importation of technology over the past few years. According to preliminary statistics, during the period of the "Sixth 5-Year Plan," \$9.2 billion in foreign currency was used to import technology, a 61.4 percent increase over the period of the "Fifth 5-Year Plan," and a large number of technology import projects were completed and put into production, which played an important role in our economic construction and in improving the standard of living for the people. During the "Seventh 5-Year Plan," relevant sectors will focus on exploring new forms and new methods for the importation of technology, which will allow the importation of technology to be greatly improved in the area of quality.

During the period of the "Sixth 5-Year Plan," the scale of our importation of technology continued to expand, and there were new changes in what was imported and the means by which it was done. For the most part, those changes were evidenced by:

1. The focus of technology importation progressively shifted from primarily importing large scale sets of equipment to build new factories to importing new technology and key equipment for the technological transformation of existing enterprises. Target areas developed in the direction of the small scale and toward the highly technology intensive, and toward a high regard for economic results and in improving product quality and expanding commodity exports.
2. The formats of technology importation developed toward the more diverse. Among the various technology importation contracts signed with foreign interests, 60 percent were contracts for trade licensing, cooperative production, advising and consulting, and technical service. In the second phase of the Baogang project in Shanghai, the majority of items made use of the formats of cooperative design and cooperative manufacture and the proportion of manufacturing for the Chinese side was expanded, which both saved expenditures of foreign exchange for this country, and also enhanced our own capacity for manufacturing equipment.

3. The professions for which technology has been imported developed toward even broader fields. The 20 sectors that include machinery, electronics, chemical engineering, light industry, petroleum, coal, building materials, metallurgy, vehicles, hydroelectricity, and textiles were all involved. For the machinery and electronics industries, importation of matched parts, components, and basic parts for production techniques and for manufacturing technology have developed most quickly.

4. The list of countries from which technology is imported has become more varied. In the past, the sources of technology imports have primarily concentrated on a few countries. Last year, in addition to Japan, West Germany, and the United States, the sources for much imported technology were France, Italy, England, Switzerland, Sweden, Denmark, Austria, and Eastern European countries. Some countries have also taken appropriate steps to relax the restrictions on exports from our country.

12586  
CSO: 4008/2112

NATIONAL DEVELOPMENTS

FUJIAN IMPORTS OPTICAL FIBER EQUIPMENT FROM ITALY

OW080259 Fuzhou FUJIAN RIBAO in Chinese 26 May 86 p 1

[By FUJIAN RIBAO reporter Chen Huibo]

[Text] A contract was signed at the restaurant of Fuzhou's foreign trade center on 25 May between the Fujian Administration of Posts and Telecommunications and Italy's (Taletera-Pirelli) Company on the import of equipment need for the completion of the first-stage Xiamen-Nanping optical fiber telecommunications project.

The first-stage Xiamen-Nanping optical fiber telecommunications project (Nanping--Yongan Sector) calls for the import of 1,920 circuits x 2 optical fiber cable and the equipment for the relative photo cell converter system. The provincial administration of posts and telecommunications finally decided to import the equipment from the (Taletera-Pirelli) Company under Italy's Fiat Group.

Attending the contract-signing ceremony were You Dexin, vice governor of Fujian; and Lin Jinquan, head of the provincial administration of posts and telecommunications; as well as Italian Ambassador to China Marras, and (Kasoli), manager of the International Department of Italy's Fiat Group.

Before the ceremony began, Xiangnan, you Dexin, and He Minxue met with Ambassador Marras and Mr (Kasoli). (Kasoli) and the other Italian guests also discussed issues of cooperation with the comrades from the provincial Economic Commission and the provincial Commission for Foreign Economic Relations and Trade.

The set of optical fiber telecommunications equipment from Italy is expected to arrive after September 1986. It will be installed, and put into operation in August 1987.

/8918  
CSO: 4008/1081

NATIONAL DEVELOPMENTS

CHEMICAL INDUSTRY NEEDS IMPORTED TECHNOLOGY

OW010620 Beijing XINHUA in English 0610 GMT 1 Jun 86

[Text] Beijing, 1 Jun (XINHUA)--Importing advanced technology for producing urgently needed chemicals is one of the priorities of the 7th five-year plan that starts from this year, said an official of the China National Chemical Engineering Corporation (CNCEC).

An Yuzong, general manager of CNEC said China expects to import equipment for extracting chemical deposits and for manufacturing compound fertilizer, basic chemical materials and refined chemicals.

Deals may be conducted in technical transfers, cooperative production, joint ventures, technical services and consultation and compensation trade, An said.

Last year, the corporation imported 108 projects and signed 248 contracts with overseas firms. Imports in this field have been shifted from complete sets of equipment to single key components, from importing whole factories to only the technology needed for updating old enterprises and from using single form of cooperation to using a variety of forms.

An said that China's export of chemical technology has also increased and he expects further growth in China's chemicals exports in the next five years.

/7051

CSO: 4010/1046

NATIONAL DEVELOPMENTS

SHANGHAI URGED TO STRESS PRODUCTION FOR EXPORT

OW221436 Beijing XINHUA in English 1412 GMT 22 Jun 86

[Text] Shanghai, 22 Jun (XINHUA)--Economists suggested Shanghai should build export-oriented production systems to promote its exports which had come to standstill for four years from 1982 according to a meeting here.

More than 100 experts from the State Council and Shanghai attended the three-day meeting which closed Saturday. It focused on Shanghai's implementation of the opening policy and development.

Experts said that Shanghai should first set up an export-oriented textile system as one third of textile enterprises there produce goods for export at present. "Textiles earn 1.8 billion U.S. dollars a year now, about a half of Shanghai's foreign exchange", the meeting was told.

"Textile enterprises are now preparing to organize enterprise groups and then set up a system integrating production with foreign trade," said Mei Shouchun, director of the Municipal Textile Bureau.

Experts estimated that the system will help increase Shanghai's textile exports from 1.8 billion to 2.5 billion U.S. dollars by 1990.

Though machinery only yields 300 million U.S. dollars a year, the industry which takes up one-third of the city's total industrial output value has a great potential for export.

During the 1986-90 period, Shanghai should streamline 100 major plants to increase exports or power generating equipment, machine-tools, tractors, medical apparatus, textile machines, bicycles, wrist watches and cameras. Those products are expected to earn 600 million U.S. dollars by 1990, doubling the current figure, according to the meeting sources.

Experts also suggested to expand export-oriented farm produce centers which will triple the current export quantity worth nearly 100 million U.S. dollars.

When discussing high-technology product centers for export, the meeting was told that by the end of the seventh five-year plan period (1986-90), micro-electronics, optical-fibre communications, new materials, laser and bio-engineering industries will produce an annual output value of three billion yuan and become foreign exchange earners by the end of the century.

"Establishment of the export-oriented system will help reform the current foreign trade management," said Uan Zengwei, an expert from the Shanghai economic research center.

Under the old management system, manufacturers learned less information on international market and requirements of importers and their products, thus, are less competitive due to the separation between industrial enterprises and trade businesses.

In recent years, about 1,000 enterprises have integrated production with foreign trade.

Ju Chongwei, an official from a research center of the State Council, stressed that establishment of export-oriented production systems is a "strategic measure" of China for expanding exports.

"Only through expansion of exports, Shanghai will be able to import more equipment, technology and use more foreign funds," vice-mayor Li Zhaoji said.

Shanghai produces one-ninth of China's manufactured goods and one-sixth of China's exports. During the 1980-85 period, Shanghai's export volume were standstill for four years, though it earned total foreign exchange of 18 billion U.S. dollars during that period, a 20 percent growth over the previous five-year period.

According to the seventh five-year plan, Shanghai's exports will grow 8.6 percent a year, amounting to 4.3 billion U.S. dollars by 1990, the meeting was told.

/7051

CSO: 4010/1046

NATIONAL DEVELOPMENTS

ELECTRONICS INDUSTRY MINISTER VIEWS DEVELOPMENTS

HK031231 Beijing GUANGMING RIBAO in Chinese 24 Jan 86 p 2

[Report by Liu Sa [0491 7366]: "AP Interview With the Minister of Electronics Industry"]

[Text] At the recent meeting of leading cadres in charge of the electronics industry, this reporter interviewed Li Tieying, minister of electronics industry on the question of how to invigorate our electronics industry by means of technological progress. He answered the following questions put by this reporter.

Question: How do you appraise the present situation in China's electronics industry?

Answer: Like China's economic situation as a whole, the present situation in its electronics industry is the best since the founding of the republic. Important signs of the situation are: 1) We have overfulfilled the "Sixth 5-Year Plan" in advance, in an all-round way. 2) We have achieved good results in scientific research and improved the quality of a number of electronics products. 3) Major successes have been achieved in capital construction, technological transformation and technological imports. 4) Through readjustments in the structure of production and the orientation of service, a bright future for an upward trend in the electronics industry has emerged. 5) There has been a good beginning in improving major relations in the development of electronics industry and raising the level of operations and management. 6) Through tremendous efforts to reform the economic structure and the systems of scientific and technological work and education, our electronics industry has embarked on a path of professional management. 7) Our further efforts in enterprise consolidation have strengthened the leading bodies of enterprises and enhanced the quality of cadres and workers. All this has laid a sound foundation for the development of electronics industry during the "Seventh 5-Year Plan." Meanwhile, the increasing needs of customers at home and abroad for electronics products will prompt enterprises to bring about better economic results and social benefit by giving full play to the existing capacity in scientific research and production. The present good situation in our country strengthens our confidence in promoting the development of the electronics industry.

Question: What are the targets set for the electronics industry in the "Seventh 5-Year Plan"?

Answer: To sum up, the tasks set in the "Seventh 5-Year Plan" are: One is to carry out reforms and the other is to promote development. The general goal for the development of the electronics industry is build it into a base for providing technological equipment for the national economy and national defence and improving the people's material and cultural lives. By 1990, it is expected that the total output value of our electronics industry will make up 3 to 4 percent of the country's industrial and agricultural gross output value, increasing at an annual average rate of about 16 percent. The taxes and profits delivered to the state will increase by 95 percent over 1985 and all-member labor productivity and foreign exchange earnings through exploration will be doubled. We will strive to raise the technical level and quality of our products to that of foreign products by the end of the 1970's and early 1980's. We have also set tasks and targets for reform of the economic structure in electronics industry.

Question: In the development of our electronics industry, are there any difficulties and problems for technological progress?

Answer: As a newly-emerged industry, our electronics industry has the following major problems: 1) We lag behind in microelectronics and computers, which are the most advanced technologies in the contemporary electronics industry. Meanwhile our electronics products are not so competitive because there is still a big gap between the quality of our products and that of foreign products. 2) The proportion of electronics products used for technological transformation in the national economy is small and electronics technology is not fully and extensively used in the national economy. 3) Our ability to absorb foreign advanced technology and independently develop the industry is limited. 4) The development of intellectual resources, and both the quantity and quality of trained people, cannot meet the needs of the development of the electronics industry. Furthermore we are short of funds for technological transformation and scientific research. All these are difficulties and problems which we have to overcome for the technological progress of our electronics industry.

Question: How does the Ministry of Electronics Industry plan to invigorate China's electronics industry by means of technological progress?

Answer: To develop new electronics technology, we will concentrate trained people and funds on establishing a number of modern scientific research centres and experimental units so as to promote the scientific and technological achievements to be used in production. Priority will be given to five major technologies--computers, integrated semiconductors, electronics for telecommunications and industry, and modern military electronics. Efforts will be made to narrow the gap between our level of major technologies and the world level. We will also readjust and reorganize the existing research institutes and build them into more concentrated scientific research organizations with multi-levels. We will select some good research institutes to engage specifically in the advanced scientific research of microelectronics,

computer, software, telecommunications, industrial electronics and military electronics in an effort to develop new technologies and new products and popularize their achievements. We will also intensify our work on quality checks of electronics products by applying international stands during the "Seventh 5-Year Plan." Ten quality-check centres will be built so that the reliability of our electronics products can be ensured and their quality can be improved. Meanwhile, we will pay attention to promoting the best products first, introducing the system of standarizing the technical equipment of enterprises and promoting rationalization of production. We will attach great importance to the development of intellectual resources, hugely increase investment in education and give full play to the enthusiasm of different sectors in training personnel for the electronics industry. Furthermore, we will also promote international exchanges and send more scientific and technological personnel abroad to pursue advanced studies. Finally, one point must be made clear. The technological advance of the electronic industry should earn vigorous support from other fraternal departments, and particularly from departments supplying industrial raw materials.

/8918

CSO: 4008/1081

NATIONAL DEVELOPMENTS

CHINA'S FIRST ROBOT RESEARCH CENTER BEING BUILT IN SHENYANG

OW311150 Beijing XINHUA in English 1132 GMT 31 Jan 86

[Text] Beijing, 31 Jan (XINHUA)--China's robot research and development center is now under construction at the Shenyang Institute of Automation attached to the Chinese Academy of Sciences.

Jiang Xinsong, director of the automation institute, told XINHUA here today that his institute in 1985 developed China's first underwater robot which can work at a depth of 200 meters.

Jiang is attending a working meeting of the science academy in Beijing.

He said China began research on robots in the 1970s and now has some 1,000 industrial manipulators and a few industrial robots, used in the fields of casting and forging, punching and heat treatment.

A graduate of Jiaotong University in Shanghai in 1956, Jiang has been engaged in research on automation, industrial control, artificial intelligence and robots for nearly 30 years.

He said robots can do some work unable to be done by man under high-temperature, poisonous and dangerous conditions.

So it is imperative to develop robots in China, he said, but the application of robots does not mainly aim at saving manpower.

China lags behind other countries such as Japan and the United States in developing robots. Jiang's view is that in research and development, China must take a road suited to its own conditions.

First of all, Jiang said, China should develop low-priced simple robots (manipulators) for raising working efficiency and reducing labor intensity. Secondly, it should develop special-purpose robots, including movable robots to work in poisonous environments, handle accidents and inspect equipment, and remote-control robots for underwater, and rescue operations and coal mining.

He expressed the view that, while introducing technology for first-generation robots from abroad, China should develop sensor equipped second-generation robots so as to reduce the gap with the advanced countries in the field.

Robot research and development has been listed as one of the country's major scientific research projects for the seventh five-year plan period (1986-1990), mainly focusing on the manufacture of industrial robots for paint-spraying, point and arc welding, and cargo-carrying.

Jiang said the production of robots involves machine-building, microscopics, control, information processing, bionic and dynamic technology. So the state must concentrate necessary funds and technical forces and take related measures to support the development of the robot industry.

The state-invested center will cover an area of eight hectares and has a floor space of 40,000 square meters, including factory buildings with numerical-control equipment and computer-aided design systems, a robot performance laboratory and a pool, 25 meters long, 25 meters wide and 12 meters deep.

Jiang said the center's main task is to develop technology for special-purpose robots. In the next five years, the center will develop underwater robots in series which can dive to depths from 300 to 600 meters, and movable remote-control robot prototypes.

By 1990, the number of researchers and scientists at the center will be 400, as against 100 at present, including 100 Chinese and foreign non-resident researchers.

He also stressed the basic research conducted at the center, with a view to preparing technological reserves for developing non-cable underwater robots able to operate at depths of 2,000 meters, and remote-control robots for coal mining in the 1990s.

He said China should expand exchanges and cooperation with foreign scientists in robot research and development. So far, the Shenyang Institute of Automation has imported underwater robot manufacturing technology from Perry Offshore Inc. of the United States, and is now discussing cooperation in the field with the National Research Center of France.

/7051

CSO: 4010/1048

NATIONAL DEVELOPMENTS

UN SPACE COMMITTEE REACHES CONSENSUS ON REMOTE SENSING ACCORD

OW140314 Beijing XINHUA in English 0005 GMT 14 Jun 86

[Text] United Nations, 13 Jun (XINHUA)--The Outer Space Committee of the United Nations today adopted with a consensus the draft principles relating to remote sensing of the earth from outer space, a great achievement after 12 years' efforts made by the committee.

The term "remote sensing" means that satellite, by making use of the property of electromagnetic waves reflected by sensed objects, senses the earth's surface from outer space, for the purpose of improving natural resources management, land use and protection of the environment.

Since 1974, the legal sub-committee of the Outer Space Committee of the United Nations began to discuss the principles relating to remote sensing of the earth from outer space in an attempt to provide common rules governing remote sensing activities in outer space to be observed by all states, to promote the development of remote sensing technology and activities by satellite, and to develop international cooperation in this field.

The draft principles adopted today stressed that "remote sensing activities shall be carried out for the benefit and in the interests of all countries, irrespective of their degree of economic, social or scientific and technological development, and taking into particular consideration the needs of the developing countries."

The document stipulates that states carrying out remote sensing activities shall promote international cooperation in the field, making available to other states opportunities for participation therein based on "equitable and mutually acceptable terms."

It says that "remote sensing shall promote the protection of the earth's natural environment." States possessing information that is capable of averting any phenomenon harmful to the earth's natural environment shall disclose such information to states concerned.

The document states that "remote sensing shall promote the protection of mankind from natural disasters." States possessing data and information that may be useful to states affected by natural disasters, or likely to be affected by impending natural disasters, shall transmit such data and information to states concerned as promptly as possible.

It stipulates that "as soon as the primary data and the processed data concerning the territory under its jurisdiction are produced, the sensed state shall have access to them on a non-discriminatory basis and on reasonable cost terms."

The document declares that "any dispute resulting from the application of these principles shall be resolved through the established procedures for the peaceful settlement of disputes."

Commenting on the draft principles, Chinese delegate He Qizhi said at the committee that the document "is a product of compromise of relevant parties," but "on the whole, the draft text is a rather practicable one, taking into account the interests of relevant sides. It is also a better result which could be reached at present." [sentence as received]

/9604

CSO: 4010/61

NATIONAL DEVELOPMENTS

DEFENSE INDUSTRY MODERNIZATION PROGRESS DISCUSSED

Beijing RENMIN RIBAO OVERSEAS EDITION in Chinese 11 May 86 p 2

[Article extracted from the JINGJI RIBAO: "New Areas for National Defense Industries to Serve Modernization"]

[Text] After adjustments and reforms during the "Sixth 5-Year Plan," China's national defense industries and enterprises have taken a very important step on the road to integration of the military with the civilian. And there were remarkable changes in commodity structures, this situation shows that under the influence of the restructuring, invigoration, and open-door policies, the series of measures taken by the state to enliven enterprises has already motivated the enthusiasm of cadre and staff in the national defense industries that have been stagnant for a long time. This sort of enormous potential that was dormant for so long will develop even more to become a new production force.

But we must also notice that production of civilian goods by the national defense industry has after all just begun, there are still many problems, primary among which are: industrial structures, commodity structures, production capacity structures, and enterprise organization structures are not yet completely rational; the technological foundation for civilian goods that are self-developed and use highly intensive manufacturing technologies is still rather weak; intellectual development and personnel training still cannot meet the needs for guaranteeing military tasks while shifting to civilian production; product quality has not sufficiently stabilized, consumption of resources and raw materials is high, and economic results have been rather slow in improving. These problems all require earnest resolution in actual practice.

For the military industry and enterprises to develop production of civilian goods, the "four services" must be achieved, i.e., serving primary projects that develop the national economy, serving invigoration of local economies, serving the lives of the people, and serving trade exports. To this end, we must adopt development strategies that are adapted to the requirements of the international marketplace and yet suit our national situation in the areas of export commodity structures, exploitation of the international marketplace, and construction of an export commodity base, and we must greatly enhance the development of export commodities. If we are to evolve from "sell whatever we

have" to "arrange for the manufacture and production of whatever the marketplace needs," there must be new products, good quality, reasonable pricing, and timely delivery of goods.

In the situation in which there is a daily reduction in production tasking for military goods and in prescriptive planning, the military industrial system must realize the full enthusiasm in the tasking just described of both sectors and local areas, and must work toward lateral economic relations. On the one hand, responsible departments must create an excellent production and operations environment for externally strengthening enterprise vitality; in another sense, existing military industries and enterprises should all be like civilian enterprises in implementing factory director responsibility systems, in intensifying comprehensive reforms within enterprises, in implementing hierarchical and specialized management, in making accounting units smaller, establishing economic responsibility systems at different levels, making full use of the advantages of national defense industries in "changing tracks and altering forms," and coming up with more outstanding results during the period of the "Seventh 5-Year Plan."

12586

CSO: 4008/2112

NATIONAL DEVELOPMENTS

BEIJING PLAYS HOST TO AERODYNAMICS CONFERENCE

OW230930 Beijing XINHUA in English 0738 GMT 23 Jun 86

[Text] Beijing, 23 Jun (XINHUA)--More than 200 Chinese and foreign experts gathered today at the Beijing Science Hall to compare notes on the latest research about the fluid dynamics of high-speed missiles, rockets, planes, and satellites.

The 10th international conference on numerical methods in fluid dynamics, sponsored by the Chinese Aerodynamics Research Society, is the first of its kind held in Asia.

Research on numerical methods includes flow fields around missiles, rockets, planes and satellites, shock wave movement of nuclear explosion, atmospheric movement, transsonic flow, and turbulence flow.

During the 5-day conference, the participants from 18 countries and regions including Britain, France, Italy, Japan, the United States, the Soviet Union and China will present 132 papers dealing with numerical simulation of flows around the flying bodies, numerical methods in fluid dynamics, accuracy of numerical solutions, boundary layer flows and vortex flows.

Zhuang Fenggan, president of the Chinese Aerodynamics Research Society, told XINHUA that China began its aerodynamics theoretical and experimental research in the 1960s. Chinese scientists have applied their research findings into such fields as aviation, astronautics, weather forecasting, textiles, nuclear science, shipbuilding, marine engineering and water conservancy.

/9604  
CSO: 4010/61

NATIONAL DEVELOPMENTS

MUNICIPAL REGULATIONS ON RADIATION PROTECTION BECOMES EFFECTIVE

SK090349 Beijing City Service in Mandarin 1000 GMT 23 Apr 86

[Text] The Beijing municipal provisional regulations radiation protection and control, jointly drawn up by the Municipal Public Health Bureau, the Municipal Public Security Bureau, and the Municipal Scientific Technological Commission, will be put into effect on 1 May.

A responsible comrade of a department concerned stressed: Those units in Beijing which engage in production, application, and marketing of radioisotope, radiant, and other radioactive materials should handle affairs in strict accordance with regulations and actually grasp the safety control work.

Over the past few years, owing to the poor management and systems, the municipality has experienced the loss of radioactive elements [Die Shi Fang She Yuan] and the accident in which radiation operators were irradiated unusually. Therefore, it is necessary to protect and control radiation with the legal system, rather than with general administrative measures.

At the municipal meeting on radiation protection held on 23 April, a responsible comrade of the Municipal Public Health Bureau called on various pertinent units to strictly control radiation in line with the Beijing municipal provisional regulations on radiation protection and control, and to conscientiously follow the license and registration systems. The radiation workers must receive physical check-ups before their employment and must receive regular physical check-ups after they are employed. At the same time, we should attend to the treatment of accidents. Those units which have created disturbances and those who are responsible for accidents should be called to account.

/8918  
CSO: 4008/1081

NATIONAL DEVELOPMENTS

CHINESE, JAPANESE SCIENTISTS TO STUDY 'KUROSHIO' CURRENT

OW210208 Beijing XINHUA in English 0153 GMT 21 May 86

["Sino-Japanese Joint Operation To Survey Black Current"--XINHUA headline]

[Text] Shanghai, 21 May (XINHUA)--Chinese and Japanese scientists have begun a 6 to 7 years-long joint survey of "Kuroshio" or black current, according to China's State Oceanic Administration today.

Chinese marine research vessels, Shijian and Xiangyanghong No 9, set off separately from Shanghai and Qingdao yesterday for the 10,000-nautical-mile survey that will cover the East China Sea and western part of the Pacific off the Japanese archipelago.

Japanese vessels were also reported to set off the same day.

Kuroshio is one of the two strongest and most spectacular ocean currents in the world. The other is the Mexican Gulf Stream. Both are known for their warm, highly saline water. The Kuroshio originates east of the Philippines, flows northward between Taiwan and the Ryukyu Islands into the East China Sea and then splits just off the Pacific coast of Japan.

According to scientists, this strong, narrow current has direct impact on the depositing and formation of the sea near China's east coast and Japan's south coast. It also influences the climate, fish resources, fishing grounds, the roving of sewage and sea routes.

The survey would be divided into four stages. During the first stage, 20 items will be conducted in the fields of hydrology, climate, chemistry and biology.

The cooperative research program was arranged by the Chinese and Japanese Government in March last year.

/9604  
CSO: 4010/61

NATIONAL DEVELOPMENTS

COMPUTER USE, TECHNOLOGY ON RISE IN PRC PROJECTS

HK040442 Beijing CHINA DAILY in English 4 Jun 86 p 1

[Article by staff reporter Nie Lishing]

[Text] Computers are no longer confined to scientific research, national defense or other State key engineering projects, but have entered almost every sector of the economy.

Cultural, medical, athletic, meteorological and public security fields are also enjoying their benefits.

More than 20,000 research and exploration projects are now using computers, compared with only several hundred five years ago, according to Li Xianglin, office director of Electronic Development Leading Group under the State Council.

He told a press conference in Beijing yesterday that the number of people working in the computer industry -- had jumped four times since 1980 to more than 100,000, not including some 5,000 teachers giving computer classes at primary and secondary schools.

Quite a number of computers can be operated in both English and Chinese, and 10 ethnic minority languages including Tibetan and Mongolian can be processed on computers. But much more headway has been made with the technology of Chinese information, Li said.

Li said that China had spent some \$200 million on importing computers, especially microcomputers. He also admitted that the country had a small stockpile of computers because it had not trained enough people to operate them. The country now has 7,000 computers and 130,000 microcomputers.

Li was briefing reporters on the national computer exhibition in Beijing which opens on Friday and runs until June 30 in celebration of the 30th anniversary of the founding of China's computer industry in 1936.

With computers being used in 19 major trades or professions, Li said, the exhibition would demonstrate China's success to raise product quality and cut production costs through computerization.

In the metallurgical industry for instance, China has transformed 120 industrial furnaces with the introduction of microcomputers and cut energy use by 15 percent, saving 36 million yuan.

The machine-building industry has developed 50 types of computer-controlled machine tools, while China National Petrochemical Corporation saved 260 million yuan in 1985 when it computerized production and management.

Computers have also been used to process data with similar success. The Ministry of Oil Industry has thus cut the cost of verifying 100 million tons of oil reserves from 790 million yuan in 1981 to 320 million in 1984.

/7051  
CSO: 4010/1046

NATIONAL DEVELOPMENTS

INVENTORS DONATE MULTI-LANGUAGE COMPUTER SYSTEMS

OW120312 Beijing XINHUA in English 0238 GMT 23 Jun 86

[Text] Beijing, 12 Jun (XINHUA)--The co-inventors of a Chinese-character computer coding method donated two multi-language computer systems to the Tianjin Scientific and Technical Association on Tuesday.

The Li brothers, Li Jinkai and Li Yimin, are teachers at Beijing Teachers University. They have also donated eight computer systems worth 300,000 yuan to the General Office of the State Council, the Everbright Industrial Company, the State Patent Bureau and three other units.

In addition, they have also donated five computer systems worth 100,000 yuan for the development of Chinese-character computer information.

They invented the stroke-coding method for computer processing of Chinese characters after a decade-long effort. With help of the Chinese State Patent Bureau, they obtained the patent right in January 1985 from a British patent bureau.

They earned more than 500,000 yuan through transfer of the patent to three computer companies in Hongkong.

Another of Li Jinkai's inventions for multi-language computer processing won a patent right from the State Patent Bureau.

The 50-year-old inventor told XINHUA that he would use the income from his patent to promote the new process.

/7051  
CSO: 4010/1046

NATIONAL DEVELOPMENTS

COMPUTERIZATION PLANNED FOR ENTERPRISES

Two Industries To Test Plan

OW241401 Beijing XINHUA in English 1332 GMT 24 Jun 86

[Text] Beijing, 24 Jun (XINHUA)--The Machinery and Electronics Industries have been selected for the trial use of computerization in Chinese industry, a national meeting was told here today.

In the machinery industry, part of the management work in more than 1,000 enterprises will be micro-computerized in 1986-90, said Lu Dong, deputy head of a leading group under the State Council for boosting the country's electronics industry.

An auxiliary computerized design system will be established for 24 product series in the machinery sector, he added.

Partially computerized information systems will be established in selected key enterprises in the electronics industry, said Lu Dong, who is also minister in charge of the state economic commission.

Another computerized system will be set up for the design of integrated circuits and other major electronic components, he added.

In 1986-90, work will start on computerizing 11 service trades such as posts and telecommunications, state economic information, banking, monitoring and control of power grids, railway transport, weather forecasting, civil aviation and the retrieval of scientific and technical information.

In the next five years, Lu Dong said, computers should be used mainly for transforming China's traditional industries and for the development of high-technology industries.

Speaking of the policy measures for promoting the country's electronics industry, Lu Dong said that the import of items which may be manufactured in China must be strictly controlled. However, he added, imports are permissible for urgently needed items and those which the country cannot produce at present.

Official Discusses Strategy

HK250226 Beijing CHINA DAILY in English 25 Jun 86 p 1

[Article by staff reporter Nie Lisheng]

[Text] China is hoping to witness a computer revolution in the next five years, as the country upgrades industry through the wide application of information technology, especially more adaptable microcomputers and their software.

Special efforts will be made to develop complete computerized management information systems at key large and medium-sized enterprises chosen for trial management modernization or major technical transformation during the Seventh Five-year Plan period, said Lu Dong, head of the State Economic Commission, yesterday.

He told a national conference on computer application that all enterprises in the machine-building and electronic industries were required to experiment with computer-assisted production and management from 1986 to 1990. Both industries are importantly committed to supply equipment to other industries.

The machine-building industry is to partially introduce microcomputers into management at more than 1,000 enterprises, and complete a computer-assisted design system for 24 major electrical machinery products. The total output value of such products is planned to reach 6 billion yuan by 1990.

A total of 29 key electronics plant are aiming to completely modernize their management by setting up computerized information and design systems for such major electronic products as integrated circuits. Some production processes will also be brought under computer control in the next five years.

Lu Dong, who is also vice director of the Electronic Development Leading Group under the State Council, said the State had also worked out plans for large computerized information systems for posts and telecommunications, State economic administration, banking transactions, power network monitoring, the Beijing-Shanghai Railway, weather forecasting and civil aviation.

To promote computer application, Lu said, the construction of all new enterprises in the next five years must include an allocation of funds for computer facilities. In existing enterprises, computers should also have priority in the use of renovation funds. Some 3 to 5 percent of their technical transformation funds should be set aside for computer application.

Preferential arrangements have been made to reduce costs and tax payments for enterprises which are active in the programme.

To support the development of domestically-produced computers, Lu said, those models that can be made in China will not be imported, while those which cannot be produced domestically may be imported only with official approval.

"Through wide application of computers, we intend to provide a market for China's own electronic products," he added.

## NATIONAL DEVELOPMENTS

### TECHNOLOGY CONTRACT LAW DISCUSSED

Tianjin KEXUEXUE YU KEXUE JISHU GUANLI [SCIENCE OF SCIENCE AND MANAGEMENT OF S&T] in Chinese No 10, 12 Oct 85 p 1

[Edited by Wang Kejian [3769 0344 0313]: "Legislation Is a Guarantee for the Reform of Science and Technology"]

[Text] Not long ago, China held a seminar on the work of science and technology laws. This meeting was convened jointly by the National Science and Technology Commission and the education, science, culture and public health committee of the National People's Congress. (See the article by Yu Desheng [0060 1795 0524] in GUOJIA KEWEI Neibu taolun 45 (1958).) The conference discussed ways to strengthen the construction of legal systems for science and technology and preliminary proposals for a legislative plan for science and technology and discussed and revised "The People's Republic of China Technology Contract Law" (draft). The work of science and technology legislation is an urgent matter. Only by straightening out legislation for the area of science and technology can the proper rights and interests of science and technology personnel as well as the smooth undertaking of reform of the institutions of science and technology be guaranteed.

I. Presently there are more than a few contradictions in the work of science and technology but because there is no law to use as a basis, we are powerless in our desire to resolve them. Manifestations of these contradictions are:

1. The entire concept of the social legal system is hazy and the idea that this law should apply to science and technology enterprises is even more hazy. For this reason, leaders at various levels very seldom consider going through legal channels to resolve various large and collective problems in the activities of science and technology.

2. Presently science and technology law is imperfect. The major manifestations of this shortcoming are: 1) the presence of a large number of legal blank spots. A great number of scientific organizations (such as scientific associations, various scientific meetings, etc.) have no corresponding laws to stipulate their legal status, rights, and obligations and the processes and conditions for obtaining government recognition. There is also a lack of legal stipulations on questions of the nature, responsibilities, rights, duties, legal status, hierarchy, and creation or elimination of research

entities of various types at various levels, such as the Research Institutes of the Chinese Academy of Sciences. The bases of scientific research such as the social mission, status, scholarly freedom, and guarantees of intellectual property rights of scientists as well as the fundamental questions of basic regulations, security measures, registration of results, insurance, methods for the transfer of results, information, publications, instrumentation, and laboratory installation in science and technology research all must have laws to provide regulation. 2) Many laws and statutes promulgated earlier have failed partially or totally due to a change of circumstances with the passage of time. That these laws have not been put in order for a long time now has led to the presence of a great number of ineffective laws mixed into the current law code, creating confusion and weakening the peoples' conception that the law must be obeyed. 3) The present system of science and technology law is not sufficient. For example, China has successively promulgated "Regulations for Recognition Awards in the Natural Sciences," "Regulations for Discovery Recognition Awards," and "Regulations for Recognition Awards for the Advancement of Science and technology." The concerns of these three sets of regulations are largely the same, yet there are not a few differences in the range of recognition awards and other areas. The entire set could well be replaced by a comprehensive set of new regulations.

3. The lack of laws directed at institutional reforms. In the reforms the complaint is often heard: "It is reasonable but not legal." Some people even go to an extreme, believing that so long as something is reasonable it does not matter if it is legal or not. They just go ahead and do it and talk about it later. This illustrates that some laws presently in force have become fetters on reform and that laws need to be established which open the way to reform.

II. In the development of science and technology, like any other enterprise, it is not enough to rely on policies and administrative measures. Such development necessarily depends on legal means. Henceforth the work of making laws for science and technology should begin with these points:

1. There must be specialized structures and working bodies to organize and control the work. First the problems of science and technology legislation must be studied on the basis of the "Resolutions of the Central Committee of the Communist Party of China on Reform of the Science and Technology System" so as to cement the results of systematic reform in science and technology in legal form. Science and technology legislation touches on work units and systems on various fronts and the laws enacted must be separately subordinate to different administrative levels.

2. Work to study this legislation must be encouraged. Science and technology are extremely complex social phenomena. They are also mutually connected with culture, education, and economics and so require comprehensive research. At the same time foreign experience must be drawn upon to engage in comparative study of the totality or of individual questions.

3. We must achieve an overall design and make formulations in turn according to the plan. Because the holes in our science and technology laws and plans are excessive, full reconstruction can easily bring about an approach where the treatment is specific to the ailment and ignores the place of each law in the overall structure. In addition, legislation is extremely practical. For this reason the legal system we design ought not to be purely a logically inferred, conceptual product but rather should largely be a response to real problems.

4. The coordination and harmonization of science and technology legislation with other law should be noted. It is not yet a settled question in scholarly circles whether or not science and technology laws or science laws ought to be drawn up alone as a single branch of legislation. But objectively science and technology definitely possess a set of social relations and so should be regulated by a systematized set of legislation. Some relations in the activities of science and technology are also found in several other areas. To use a single law to regulate relationships with a similar nature and content across many areas is frequently very reasonable.

5. All non-legal documents presently in force should be cleaned up to make them legal. Presently, with regard to a large quantity of documents, reports, and addresses, the implementation has been "to do as one pleases" and for "each to take what he needs." This is a major fear in the establishment of law. These sorts of documents and addresses should be cleaned up and have their reasonable parts incorporated into legal documents so as to legalize them.

12966/12795  
CSO: 4008/2033

## NATIONAL DEVELOPMENTS

### SHANGHAI ADVANCES IN TECHNOLOGICAL DEVELOPMENT

OW182013 Beijing XINHUA Domestic Service in Chinese 2330 GMT 17 Jun 86

[By reporters Shen Shiwei and Wu Mingfei]

[Excerpts] Shanghai, 18 Jun (XINHUA)--Shanghai, the largest central city of China, is making full use of its favorable conditions of a sound technological foundation and large numbers of technicians to catch up with the advanced world technological level and to speed up the application of new technologies to production. Now a variety of new technologies, such as microelectronics, bioengineering, optical fiber communications, and marine engineering, have been applied to various production fields.

A computer-controlled 256-line automatic telegram transmission system developed by the Shanghai Long Distance Telecommunications Bureau in collaboration with other units has reduced the time required for transmitting a telegram from an average of 37 minutes to less than 3 minutes with a considerably smaller chance of errors. This automatic telegram transmission system has been put to use in Shanghai. Since last March, efforts have also been made to introduce it to other cities in the country. In the meantime, thanks to the joint efforts of scientists and technicians from various quarters, good news about Shanghai's achievement in developing integrated circuits has poured in, unfolding a broad prospect for the development of microelectronics.

During the past few years, six institutions of high learning and scientific research organizations, including the Shanghai Silicate Chemistry Technology Institute of the Chinese Academy of Sciences and the No 23 institute of the Ministry of Electronics Industry, have formed "pairs" with some factories and have thus put to use the major research results they have achieved in the field of optical fiber communications. Work has started to produce various kinds of terminal equipment and photoelectric equipment and parts. Some optical fiber communications systems have been put to use in the city's telephone, electric power, radio and television, public security, and transportation departments. These systems have also been supplied to Tianjin, Nanjing, and other cities.

The municipal government has recently decided to build a high technology Industrial Zone--known as the Caohejing High Technology Industrial Zone--and to develop the production of computers, large-scale integrated circuits, optical fiber communications equipment, and laser equipment. Now construction of a large-scale integrated circuit production project using technology introduced from abroad has already started.

NATIONAL DEVELOPMENTS

DOW TRANSFERS TECHNOLOGY TO YANSHAN PLANT

OW181652 Beijing XINHUA in English 1441 GMT 18 Jun 86

[Text] Hong Kong, 18 Jun (XINHUA)--The U.S.-based Dow Chemical Company has signed a technology-licensing agreement with China for the start-up of a polystyrene plant near Beijing in 1989.

Under the agreement, Dow will provide technology, and help in the design, engineering, and procurement of equipment for the plant, Colin D. Goodchild, president of Dow Chemical Pacific Ltd. said here today.

Located at Yanshan on the outskirts of Beijing, the plant will have an annual capacity of 50,000 metric tons.

The agreement, the second of its kind between Dow and China, was signed here 12 June. The first contract was signed in 1984 for the manufacture of cable shielding tape at a wire and cable plant in Chengdu, southwest China.

The Yanshan plant will use styrene monomer and other raw materials produced in China. Some of the plant technicians and engineers will be trained at Dow's Tsing Yi Polystyrene Plant in Hong Kong.

"The increased polystyrene capacity will greatly benefit China's plastic industry," said Goodchild. "We at Dow view the technology-licensing agreement as an important step in further strengthening our commercial ties with the People's Republic of China."

/7051  
CSO: 4010/1048

NATIONAL DEVELOPMENTS

FOREIGN S&T COOPERATION, LEGAL PROTECTIONS DISCUSSED

Tianjin KEXUE XUE YU KEXUE JISHU GUANLI [SCIENCE OF SCIENCE AND MANAGEMENT OF S&T] in Chinese No 10, 12 Oct 85 pp 7-8

[Article by Yang Peilin [2799 0160 3829] of the Shanghai Family Planning Institute: "Foreign S&T Cooperation Must Have the Protection of Law"]

[Text] Since the 3d Plenum of the 11th National Party Congress, the number of cooperative science and technology projects with foreign countries with which China has agreements with has reached 2,700. The rapid development of the situation not only illustrates the profound public support for the policy of opening to the outside, it also signifies that legal questions concerning science and technology cooperation cannot be regarded as unimportant.

Cooperation is basically a kind of scholarly research activity. With the emergence of an industrial property rights system, the results of cooperative research of an international nature not only comes under the category of technology but also impinges on questions of law. This indicates that the rights and responsibilities stipulated in agreements of cooperation by both sides must attain legal confirmation before they can be implemented and carried out smoothly. Now, with the joint-research regulations of the United Nations World Health Organization as an example, the central components of an international agreement are considered to be:

1. Technological information, exclusive patents, and research results (biology and chemistry ought to be samples of comparable quantity) as well as technological innovations communicated orally which are obtained from research projects subsidized by this agreement must all be freely provided to the World Health Organization or agencies designated by this organization.
2. If research results can be converted into products, technologies, or information which is sold, with an economic gain, this organization has the right to a share of the income in proportion to its contribution based on the agreement.
3. In the event of a dispute over cooperative research, if the two sides are unable to come to an understanding on their own, they must submit to the mediation of a third party which both sides have accepted. If the mediation fails, then the arbitration regulations of the World Chamber of Commerce will resolve the issue.

What counter measures do we have in response to these provisions? This is regrettable because our science and technology legislation is still a blank spot. Many units with 4 or 5 years of international cooperation can only follow general science and technology policies in guiding the implementation of particular cooperation agreements. The Zhang kuan li dai cooperative work is only carried out by improvisation. Some departments have fixed a certain number of regulations on their own but are suffering from inconsistency in the requirements and a lack of authoritativeness and a scientific nature. This has gotten to the point that with the development of joint research and the consequent production of a large set of questions such as patents and proportion of profit from results there is even less of a call for unification. Frequently it is a case of withdrawing from talks before they begin and the absence of any consensus. Some people say: "We can't refuse to talk, but we can't talk about everything." Others say: "The important things don't get talked about." And not a few hold the opinion that in a joint project secrecy questions do not exist. In fact these conditions, where there is no law to rely on, have bred various sorts of dangerous factors which are no help to the smooth implementation of the cooperative projects. One unit which had already signed the above agreement with an international company found itself in the situation where it had difficulty completely making known its participation in national research because of the limits of various regulations. At this point the foreign partner asked: "United Nations joint projects are precisely for the purpose of giving full play to the function of your unit within China. Yet you haven't undertaken even a single national project. How are people to make sense of this?" There was a pharmaceutical cooperative task where due to restrictions by various factors on our side, we were not able to deliver the samples and make headway according to the stipulated time table. The result was that the foreign side reduced its \$150,000 subsidy to \$60,000. Not only this, the foreign partner in a report also said that the leadership of this cooperative task was ineffective, which truly put the cooperating unit in a dilemma. To manage things according to the agreement violated regulations and not to manage them according to the agreement meant that there would be no way to continue the cooperation.

In theory, equal mutual benefits are the motive and goal of joint cooperation. Everyone invests capital and expends labor and no one will be courteous to the point of being unconcerned with patents or not asking about results. Illustrated in practice, many foreign organizations and structures have far richer experience and learning in the area of cooperative research than does China. In the development of cooperation and the administration of various programs they more heavily stress doing things according to the agreements and take the contract regulations as the norm. In this situation, to have people continue to ignore the stipulations in agreements concerning the sharing of results or to cling to the idea of counteracting the past by trusting luck, just discussing superficialities and not discussing substance, is extremely naive. Similarly, they way of doing things where scruples are lost as soon as cooperation is mentioned and where the various units compete to demonstrate their "research strength" to foreign countries also will not do.

In the final analysis, so long as there are only agreements without legal guarantees, some cooperative programs will have a hard time avoiding difficulties in execution or working blindly.

In recent years, China has established "Laws for Economic Cooperation Between the People's Republic of China and Foreign Countries," "Laws for Investment," etc., which have effectively promoted foreign economic cooperation. In the area of science and technology cooperation the various departments also are not without models of accomplishment and methods of efficiency. The problem is how to unify experience and methods according to the spirit of reform and openness and to formulate procedures for serious science and technology cooperation which are in accord with China's situation. This will allow the various kinds of cooperative agreements to cast off restrictive constraints of very different sorts and replace them with signed contracts, implementing them under guarantees with the force of law. According to this approach, all the programs that China carries on independently need not come within the scope of cooperation and all those programs that are cooperative, to the level of entire units (like the Joint Capital Research Institute) will have any contradictions over patents and sharing of results resolved in the spirit of the agreement. What has been learned from 5 years of practice indicates that this is one key to guaranteeing the development of Chinese-foreign science and technology cooperation.

12966/12795  
CSO: 4008/2033

NATIONAL DEVELOPMENTS

SEMINAR ON MEDICAL IMAGING TECHNOLOGY OPENS

OW181310 Beijing XINHUA in English 1204 GMT 18 Jun 86

[Text] Beijing, 18 Jun (XINHUA)--Major hospitals and medical colleges in China's various provinces, municipalities and autonomous regions are now equipped with x-ray computerized tomography machines, thus greatly improving their clinical diagnostic level.

This was disclosed at a seminar on medical imaging technology, sponsored by the Chinese association of medical imaging technology, which opened here today.

Computerized tomography has enabled doctors to obtain accurate diagnostic images of human organs and tissues including the brain, heart, liver and pancreas.

In recent years Chinese scientists have developed a number of items of medical imaging equipment. The Shanghai Medical Electronic Equipment Plant has produced a line-array electronic-scan diagnostic system for examining the brain, liver, gland, gallbladder and other human organs. Beijing's Qinghua University and the Shanghai Medical Meter Factory have jointly developed a duplex ultrasound diagnostic system with a digital-scan converter. The system can produce clearer images of the cardiovascular system, and the speed and direction of blood flow.

During the three-day seminar more than 500 scientists and doctors from across the country will share their experiences related to computerized tomography, ultrasound tomography, nuclear medical imaging technology, medical image processing and medical electronic microscopy.

At today's opening ceremony, vice-president of the Chinese Association of Medical Imaging Technology, Xie Nanzhu, gave a lecture entitled, "New progress in modern medical imaging technology."

/7051  
CSO: 4010/1047

NATIONAL DEVELOPMENTS

PUBLIC HEALTH VICE-MINISTER ON TRADITIONAL MEDICINE

OW140054 Beijing XINHUA in English 0046 GMT 14 May 86

[Text] Beijing, 14 May (XINHUA)--China plans to train 60,000 more doctors and pharmacists of traditional Chinese medicine in the 1986-90 period, about three times the total over the past three decades, said Hu Ximing, Vice-Minister of public health.

In an interview with XINHUA, the Vice-Minister said traditional Chinese medicine has particular advantages and is popular among Chinese people, especially the 800 million peasants.

Many developed countries are also trying to develop natural medicines and non-drug therapy as the harmful effects of chemical drugs and chronic and difficult cases that Western medicine can not effectively control become more apparent.

More than 1,000 doctors from 120 countries have come to China to receive training in acupuncture and moxibustion, and other traditional Chinese therapies since the 1970s.

Hu, former doctor of traditional medicine, showed concern about shortage of personnel and medicinal herbs, inadequate facilities and poor management in this field due to negligence in the past.

Chinese leaders Deng Xiaoping and Zhao Ziyang have stressed development of Chinese medicine repeatedly in recent years.

In January this year, the State Council decided to set up a State Administration of Traditional Chinese Medicine.

"This is a milestone in the development of traditional Chinese medicine," Hu said.

In the development of traditional medicine, the Vice-Minister stressed scientific research.

It is necessary to enrich and develop the teaching of and research into traditional medicine with advanced technology and scientific methods," he said.

/7051  
CSO: 4010-1048

NATIONAL DEVELOPMENTS

NUMBER OF PRIVATE DOCTORS, DENTISTS INCREASES

HK110328 Beijing CHINA DAILY in English 11 Jun 86 p 3

[Text] The number of private doctors, dentists and nurses has risen to 116,000, the national HEALTH NEWS newspaper said this week.

The paper said the boom of private practitioners in China has eased the pressure on State-run hospitals and clinics which are usually crowded. It has also made medical services more convenient for the people.

Most of the private doctors are in retirement and they specialize in dentistry, orthopaedics, and traditional Chinese medicine. Such clinics are in great demand and they are made within easy reach by the private doctors, the paper said.

The paper called for more flexible policies to encourage more medical veterans to engage in private practicing.

China started to allow retired doctors to open their own businesses in 1980. By 1984, there were 80,000 private doctors across the country. Doctors and nurses in active services were allowed to offer services in their spare time and earnings from such services went entirely to the providers themselves, but deductions were made when public medical apparatus were used.

The HEALTH NEWS said despite the obvious benefits brought about by the private doctors, many government departments in charge of the country's medical system still hold the steadfast belief that it is not necessary to have private doctors since the State-run hospitals and clinics can provide basically every kind of service.

According to experts, the need to allow doctors to practise privately lies in the fact that there is only an average of 2.07 State hospital beds and 1.35 doctors for every 1,000 people in China. This puts heavy pressure on the existing State-run facilities.

Urged by the Ministry of Public Health, big and small cities are simplifying the procedures for private doctors to register. In Shanghai, for example, the city authorities have announced that medical professionals retired from State-owned hospitals would continue to enjoy their retirement benefits after they start private practices.

However, the paper said, the examination of the qualification of the private doctors should be strict in order to protect the interests of the people.

NATIONAL DEVELOPMENTS

DEVELOPMENT STRATEGY FOR TIANJIN'S COLLEGES DISCUSSED

Tianjin KEXUEXUE YU KEXUE JISHU GUANLI [SCIENCE OF SCIENCE AND MANAGEMENT OF S&T]  
in Chinese No 10, 12 Oct 85 pp 16-18

[Article by Zeng Di [2582 3321] of Nankai University: "A Model for the Year 2000"]

[Text] The level of education is a major index of the economic strength and the standard of science and technology of contemporary nations and regions. In 1977 in the United States for every 10,000 persons there were 523 college students. In 1982 in Tianjin for every 10,000 persons there were 50 college students. The United States had about 10.2 times as many students as Tianjin. Average per-capita income in the United States is \$13,000. For Tianjin average per-capita income is \$1,800. Per-capita income in the United States is about 7.2 times higher than in Tianjin. This illustrates that if the labor productivity of Tianjin is to be raised to the level of the United States, secondary occupational education (including senior middle school) must be increased by at least a factor of three and higher education must be increased at least tenfold. Thus the educational strategy of Tianjin ought to take the present educational levels of the United States as a reference system, striving within this century to attain the average standard of the United States in the early 1980's. This historic mission will be completed in two steps.

I. The first step began in 1984 and will increase annually by 15 percent in 1990. Based on an increase of 16.5 percent in enrollment in general higher education between 1983 and 1984, it seems that the ability of the local administration of Tianjin to sustain this over the coming years is sufficient to accomplish the goal.

This step will require the resolution of several related questions.

The first problem is the question of speed and quality. The quality of Tianjin's local higher educational institutions is rather thin and weak, so there are difficulties with supporting a rate of development that is higher than economic growth. But there exists here also the conditions and possibilities to resolve the problem. The first of these is that there is a higher education teaching corps of 10,000. Second, there are over 200 research institutes, a portion of whose strength can be used to expand higher education. Third, Tianjin is a more developed port city and has broad connections both

abroad and at home. Moreover, Tianjin has the capital, Beijing, very close at hand and there are various sorts of good information channels. The reason that the possibility for rapid development exists is that presently education is emphasized in the strategy for the socialist modernization plan and has received widespread emphasis. The function of science and technology is extremely prominent in its role as corrective remodeler for productive strength in industrial construction and concentration of technologies. This situation makes the expansion of the quantity and the increase in the quality of higher education into objective pressing needs for social and economic development.

The second problem is the educational structure and the question of proportions. The educational structure in Tianjin, viewed from the macroscopic level, has a severe imbalance between the natural and social sciences. Social and economic sciences in particular have been ignored for a long period. The goal of Tianjin's economic strategy is to participate in international competition in finance, trade, technology, and commerce.

The construction of the various disciplines within the natural sciences also requires adjustment. The number of health technicians in Tianjin is the highest in the world. At 0.54 percent of the population this is more than twice as much as in countries with relatively high standards of medical treatment. Higher educational institutional health education is at 9.4 percent, also by proportion the highest region, and is even 25 percent higher than in the Soviet Union where medical education is stressed more than anywhere else. Medical personnel in the Soviet Union constitute 0.32 percent of the population. For this reason, the areas of medical treatment and health education in Tianjin ought to be reduced to appropriate proportions and the standards of higher education in these fields should be raised.

The direction of structural reform in education must serve the strategy of economic development. The total economic strategy of Tianjin is to use completely and energetically the superiority of the city opened by the port to expand the comprehensive processing of imported and exported first-level products. In the chemical, food, electronics, textile, construction, and information industries as well as the service trades, rapid and high-quality increases are sought to bring about an economic structure with commerce, finance, and trade as its principal components. In this, the emphasis naturally will be on the development of the enumerated industries and the disciplines in the areas of commerce, finance, and trade.

The third problem is the question of investing and fund raising. Because the proportionate educational investment in China is pitifully small, at the very low end of over 100 countries, it would be extremely difficult to rely only on domestic investment to close this gap. For this reason, we must raise capital from various areas to set up new universities. In the constitution, higher education is not compulsory, so it is appropriate that students pay tuition. This is also a means through which funds may be supplemented. In the present stage where state, collective, and individual economic sectors coexist, higher education need not be managed entirely by the government alone.

There is no harm in having multiple forms of fund raising to operate schools. The government can provide guidance only on the basis of law and would not intervene in the authority of the school in the rational use and distribution of people, finances, and material. With this problem resolved then the financial avenues for managing education would be broadly opened. Moreover, the widely recruitment of talent to manage education can be done and intelligent investment and the opening up of intellect can begin.

To what proportion should educational investment in Tianjin be revised. This depends at what level the strategic goals of Tianjin's social and economic development are set. If Tianjin wants to attain an advanced level taking the lead in developing the nation in areas of society, economy, and science and technology, then by the beginning of the 1990's we must reach a level of educational investment between 4 and 5 percent of the GNP.

The fourth problem is the question of undergraduate versus professional education. In a highly developed society like the United States, the ratio of undergraduates to professional students is 2 to 1, whereas in a lagging economy such as our own nearly all higher education is undergraduate, which is an unwise policy. The cost of a single 2-year professional graduate is about one-third that of educating a 4-year undergraduate and there is hardly any difference when they get to basic enterprises and engage in technological service for productiveness. This is so because for work in production technologies everyone requires training and the systematic theoretical knowledge possessed by undergraduates is not that useful. Within the next 5 years, Tianjin will at least adjust the ratio of undergraduate to professional students to 3 to 1 or 4 to 1. To complete this task is not at all difficult. It can be done simply by insuring that the present number of undergraduates does not increase while at the same time energetically working out professional study programs. This will foster the potential of the older faculty but without putting excessive added pressure on the schools. As a rule, professional students in the city are day students. In the next few years the major difficulty facing educational expansion will be to keep pace with the basic plan but this method will expand the quantity of graduates, satisfy the urgent needs of industry, and at the same time give consideration to the schools' ability to support the growth.

The fifth problem is the question of the ratio between teaching and administrative staff and students. In Tianjin the ratio of higher education faculty to students is 1 to 3.9 while in most of developed countries it is 1 to 16, with some reaching 1 to 20. Obviously, the burden of Tianjin's teachers is only one-fourth that of these countries. Only by improving the living conditions of teachers can the ability of these teachers to support more students be increased. This implies that to complete the first-step goal it is not necessary to increase the number of teachers but we must implement necessary replacements, including turning teaching assistantship work over to graduate students. There is also the effective method of reducing the staff and worker corps, which would be to socialize a school's logistical service work. Otherwise, increased educational funding could be eaten up by constantly expanding the staff and worker corps so that there could not be more expansion.

The sixth problem is the question of standard versus non-standard education. In China there has been a rapid development of occupational education in recent years. This is an important part of higher education and is a sure course to speed the "intellectualization" of cadres. At present it also is a major supplement to higher education to correct the unreasonable situation of higher education's vertical structure. By the 1990's and after, when secondary education is universal and after higher education has taken a large step forward, occupational education will enter a high-level stage of expansion. Entering into the information age, new knowledge, new technology, and new industries will double in 5 or 6 years and education will always be the foundation although increasingly it will be unable to satisfy the needs of an expanding society and economy. Since the standard of Tianjin's occupational education is uneven and its quality is difficult to test and guarantee, we propose to establish a unified testing committee and repository of test questions. Study can be done broadly but one must pass the test subjects stipulated by the testing committee before receiving a diploma. If there is to be broadly developed occupational education there must also be strict regulation of student status. This is a complementary aspect of a single question. If we are firmly to block the phenomenon of possessing diplomas to "win promotion" then diplomas ought to possess legal seriousness and scientific authority.

II. For the goal of the second step we would do well to select three expansion speeds (i.e., rates of annual increase in students at higher educational institutions from 1990 to 2000 of 10 percent, 15 percent, and 20 percent to see the conditions of the realization of the first step and to implement a "rolling" plan (goals).

We project that by the year 2000, the population of Tianjin will be at least 10 million. If educational development follows the first rate, Tianjin will attain the levels of higher education Japan, West Germany, France, and the East European countries had in the late Nineteen Seventies. If development is according to the third rate the level of higher education in the United States at the end of the 1970's will be attained, and if the expansion follows the second rate, Tianjin could overtake or approach the levels of Japan, West Germany, France, and the various East European countries because the rates of increase of these countries since the 1980's has been lower. The United States has already reached a state of saturation where it has passed the period of increasing quantity and is in the stage of improving quality and expanding scientific research.

The goal of Tianjin's economic strategy is to increase the total output value from 20 billion yuan in 1980 to 100 billion yuan by the year 2000, a fivefold increase. If the expansion of higher education is to proceed in the same proportion, then the 30,000 students of 1980 should increase to 150,000 by the year 2000. The annual rate of growth to achieve this speed of expansion is 8.5 percent. If, for the next 15 years, Tianjin can insure a rate of increase in educational funds of 16 percent, then to attain the general level of higher education the United States had in the late 1970's is entirely possible. This is because the attendance rate of 6 years of elementary

education in Tianjin has already reached 99 percent and for 9 years of primary education it is 76 percent. With a period of 3 or 5 more years, 9 years of primary education can become universal. In order to achieve this aspect of educational growth we must improve school conditions and raise the quality of instruction. The major task of the next 5 years is to expand secondary school attendance (senior middle school) and various kinds of vocational and technical education, to go from the present level of 27 percent to 80 percent to provide the intellectual preparation for a large expansion in universal higher education and vocational higher education in the next decade. For the first 5 years a larger part of the increases in educational funds will be used for expanding secondary education but for the 10 years after that the part for expanding higher education will be the greater share. Because the fundamental thing for education is the future, higher education must do the preparatory work of opening minds and fostering talent for future social and economic expansion. Whether this preparatory work is complete or not will determine the speed and quality of future development. How well-off the Chinese economy will be at the end of this century and whether it surpasses the economic level of industrially developed countries in the 21st century will be determined by the degree of development of education in the next dozen or so years. The history of various countries in the world in the last few decades has shown that the average level of education in a country is in direct proportion to the economic strength of that country. The educational development in various areas in China is uneven but is also in direct proportion to the economic strength of a given area. Presently the level of higher education in Tianjin is 2.7 times the national average and Tianjin's labor productivity is 2.5 times the national average. If Tianjin is to maintain its economic position as the third largest city it can only firmly grasp the two stages outlined above for educational expansion in the next 15 years. Along with implementing the plan for the second stage, in addition to continuing to complete the reform of the six problems of the first stage, the following three problems must also be resolved:

First, Tianjin is a central city open both internally and to the outside. In addition to opening up the intellectual resources of the city itself, attracting outside intellectual resources ought also to be encouraged, especially those from the interior. Intellectual resources differ from material resources in that they become more fruitful the more they are exploited. The development of China's various areas has been uneven. As the relatively advanced coastal cities attract and open up to intellectual resources from the interior, this will speed the development of the coastal cities and can also assist in the exploitation of intellectual resources in the interior. Opening up education will be of limitless benefit to Tianjin.

Second, this stage will serve as preparation for the urgent situation in the expansion of the world economy and in science and technology. The first stage mostly will modify the tendencies and horizontal structure of higher education for the needs of Tianjin itself to insure the various types of talent needed for Tianjin's development. But the point of emphasis for this stage ought to be to foster competitive talent which can participate in the world market economy.

Third, research on the intellectual development and individual guidance of only children must in particular be stressed. This is a great problem related to the success or failure of second-stage education. Moreover, it is a question specific to China in the next few decades. Sociologists, psychologists, and educators must work together diligently to study the educational problems of only children. If it is not done right, it could become a serious obstacle to intellectual development.

12966/12795  
CSO: 4008/2033

NATIONAL DEVELOPMENTS

BRIEFS

GUIZHOU ORGANIC GEOCHEMISTRY WORKSHOP--Guiyang, 13 June (XINHUA)--Chinese Organic Geochemistry is at an advanced level, according to a leading European scientist. P.A. Schenck, chairman of the European Society for Organic Geochemistry, has been attending a seven-day workshop which closed today in this capital of southwest China's Guizhou Province. Schenck said that he and other foreign scientists were all impressed by the work of their Chinese colleagues. An example Schenck cited was that the Chinese scientists had been able to analyze and appraise two kinds of compounds--steranoid and terpanoid---which have complicated structures. The workshop was organized by the U.N. Development Program (UNDP), UNESCO and the Geochemistry Institute of the Chinese Academy of Sciences based in Guizhou Province. During the workshop, five foreign scientists and more than 100 Chinese scholars exchanged their latest findings in the area of biomarkers and kerogens, which are of significance for oil prospecting. Altogether, 37 academic papers, including 17 by foreign experts, were read at the workshop. The five foreign scientists and 13 Chinese experts gave lectures. [Text] [Beijing XINHUA IN English 1740 GMT 13 Jun 86 OW] /7051

CONTROL-SYSTEM SOFTWARE PACKAGE DEVELOPED --Beijing, 20 June (XINHUA)--A control system software, the China control systems computer-aided design package, the largest ever achieved in China, has passed state certification test. Developed by more than 100 experts from 17 specialized research institutions and colleges, the package will help to upgrade the analysis and design of the control system and raise its calculating efficiency. Consisting of 19 sub-packages and two base banks, the software package can well function in system identification, mathematical modelling, analysis, design, forecast of the control system. Trial use of some of the sub-packages in the process of the research work has shown satisfying results. A Beijing chemical plant, for example, by using the control system software package, can now calculate the model parameter of the synthetic ethylene acetic acid in a few or dozens of minutes instead of several days previously. Calling it important to the development of the computer industry and control systems, experts said that the newly-developed software package has filled the gap in China's automatic control system calculation and computer-aided software. [Text] [Beijing XINHUA in English 0111 GMT 20 Jun 86 OW] /7051

STATE COUNCIL LIMITS INTEGRATED CIRCUIT IMPORTS--Beijing, 24 Jun (XINHUA)--Today's economic news in brief (2): Imports of integrated circuit limited. The Chinese State Council has decided to limit imports of integrated circuits in a bid to develop China's own products, and the Ministry of Electronics Industry will work out detailed regulations to govern the imports. [Excerpts] [Beijing XINHUA in English 1411 GMT 24 Jun 86 OW] /7051

JOURNALISTS ESTABLISH ENVIRONMENTAL FORUM --A China Environmental Journalists' Forum has been set up in Beijing to organize mass media workers in their effort for environmental protection through publicity. Representing 37 newspapers, periodicals and press agencies, the association will also promote professional cooperation and coordination among media institutions both at home and abroad. It will mobilize government departments and the whole of society to support journalists in their work for environmental protection for the benefit of all mankind. Early last week, the association received a delegation of environmental journalists from the Asia-Pacific Economic and Social Council and exchanged experiences about the media work for environmental protection. [Text] [Beijing CHINA DAILY in English 12 Jun 86 p 3 HK] /7051

LARGEST RADIO TELESCOPE--Beijing, 15 Jun (XINHUA)--China has begun to build a radio astronomical observatory at the Sheshan Station in Shanghai, "Science News" reports. A 25-meter radio telescope, the largest ever in China, will be installed there. The paper disclosed that China will cooperate with Japan, Federal Germany and other countries in using the radio telescope to carry out joint experiments. The 25-meter radio telescope was developed by the Shanghai Observatory and an institute of the Ministry of Electronics Industry. It is used in measuring base line parameters, revolution of the earth, movement of earth plates, seismological studies and in the study of the position and fine structure of radio sources. It has been used to observe the continuous radio spectrum and the OH line of Halley's Comet earlier this year. [Text] [Beijing XINHUA in English 0615 GMT 15 Jun 86 OW] /7051

YUELI CHAIRMAN OF PHARMACOPOEIA COMMITTEE--The Fifth National Pharmacopoeia Committee was inaugurated today in Beijing. The committee is composed of some 150 experts, professors, and engineers from the fields of traditional Chinese and Western medicine, biology, botany, and chemistry. Cui Yueli, minister of public health, was named its chairman. Vice Public Health Minister Chen Minzhang said today that the compilation of the pharmacopoeia will create important conditions for the implementation of the "PRC Pharmaceuticals Control Law." He expressed the wish that the committee members will do their utmost to strengthen the standardization of pharmaceuticals in China and for the implementation of the Pharmaceuticals Control Law. [Excerpts] [Beijing XINHUA Domestic Service in Chinese 1324 GMT 5 May 86 OW] /8918

CSO: 4008/1081

Applied Acoustics

ACOUSTIC LEVITATION TECHNIQUE AND ITS APPLICATIONS

Beijing YINGYONG SHENGXUE [APPLIED ACOUSTICS] in Chinese Vol 5 No 2, Apr 86  
pp 1-6

[Article by Zhu Zhemin [2612 0772 3046], Institute of Acoustics, Nanjing  
University]

[Abstract] The acoustic levitation technique is a new, effective experiment means involving steadily levitating a small object within an acoustic field using the acoustic method in order to study mechanical properties related to acoustic waves. In the acoustic levitation technique, this kind of levitation force is mainly provided by the second-order acoustic radiation pressure, non-time-varying. The paper briefly introduces the theoretical fundamentals, experimental setup, and typical and potential applications of the acoustic levitation technique based on the author's work and his related contacts in the United States. One table lists the data of theoretical and experimental values (for sake of comparison) of fundamental frequency. Five figures show an acoustic levitation setup with and without corpuscles, a circuit layout in the modulating radiation pressure method, a fundamental frequency mode with symmetric acoustic axis, and pictures of mode showing an oil droplet. The paper was compiled from a report at the Third All China Applied Acoustics Symposium in November 1984.

REFERENCES:

1. Apfel, R. E., NATURE PHYSICAL SCIENCE, 233-41 (1971), 119.
2. Apfel, R. E., J. ACOUST. SOC. AM., 59-2 (1976), 339.
3. Apfel, R. E. and Harbison, J. P., J. ACOUST. SOC. AM., 57-6 (1975), 1371.
4. Varanasi, U. et al., CHEMISTRY AND PHYSICS OF LIQUIDS, 19 (1977), 179.
5. Apfel, R. E. et al., J. ACOUST. SOC. AM., 62 (1977) Supp., S55.
6. Apfel, R. E., NAVAL RESEARCH REVIEWS, 8 (1978), 30.
7. Trinh, E. and Wang, T. G., J. ACOUST. SOC. AM., 68 (1980), (Si) S45.
8. Lierke, E. G., J. ACOUST. SOC. AM., 60 (1976), S21.
9. Wang, T. G., IEEE Ultrasonic Symposium 1983, 1124.
10. Goosby, S. G. and Marston, P. L., J. ACOUST. SOC. AM., 68 (1980), S30.
11. Beyer, R. T., "Nonlinear Acoustics" Naval Ship Systems Command, Washington, D.C., 1974.
12. Yosioka, K. and Kawasima, Y., ACOUSTICA, 5 (1955), 167.
13. Marston, P. L., J. ACOUST. SOC. AM., 67-1 (1980), 15.
14. Marston, P. L. and Apfel, R. E., J. ACOUST. SOC. AM., 74 (1983), S27.
15. Zhu Zheming and Apfel, R. E., J. ACOUST. SOC. AM., 74 (1983), S27.

ACOUSTICAL MULTITARGET SYSTEM FOR SYNTHETIC MEASUREMENT OF EXTERIOR TRAJECTORIES

Beijing YINGYONG SHENGXUE [APPLIED ACOUSTICS] in Chinese Vol 5 No 2, Apr 86  
pp 15-18

[Article by Yan Zhengxian [0917 2973 6343], Institute of Acoustics, Chinese Academy of Sciences]

[Abstract] This paper reports on a comprehensive test system for exterior trajectories, utilizing the positioning principle of an acoustical target. In the man-machine dialogue, mode testing can be done with a multi-target system or with one of the targets. This is a new, comprehensive analysis system for the exterior-trajectory-performance of light-weapon bullets, providing a new means for exterior trajectory study with the test functions of a single bullet, but with multiple parameters. A group of bullets (generally 20 in number) can be tested for almost all parameters including the center of mass of the bullet involved. The curves thus recorded have a coincidence degree of more than 0.99. The system performance and automation are unsurpassed by any other target trajectory testing systems. One table shows the test accuracy. Four figures show shock waves in the air during the bullets' flight, acoustical positioning, output waveform and signal transformation of transducers with two-bullet fixed firing, and measurement of time differences.

COMPUTER COMPILATION OF TABLES FOR DESIGNING ULTRASONIC VELOCITY TRANSFORMERS  
(III)--SIMPLE TORSIONAL TRANSFORMERS

Beijing YINGYONG SHENGXUE [APPLIED ACOUSTICS] in Chinese Vol 5 No 2, Apr 86  
pp 22-28, 31

[Article by Yuan Shixun [7086 0013 8113], Guangxi University]

[Abstract] The article discusses torsional transformers: index, quasi-cone, quasi-catenary and step (composed of two sections of equal-length cylinders) types. Also described are theoretical calculation formulas on the main parameters, as well as three computer-compiled (data) design tables with diameter ratios of 1.01 through 7.00, and design equations listed in the fourth table. Two figures show comparative curves of parameters and the variable cross-sectional areas of a torsional circular-variable amplitude rod. From these data, the index and quasi-catenary types have better comprehensive features while the step type has quite a large amplification coefficient and thus is easily machined. The general contents of the article were reported at the 1983 All China Supersonic Power Symposium. The author is grateful to associate professor Wang Jihao [3769 1142 3185] and computer room colleagues for their support. The article was received for publication on 27 February 1984.

70 MHz SURFACE ACOUSTIC WAVE 63 CHIP BY-PHASE CODED DELAY LINE OF M<sub>32</sub> SEQUENCE

Beijing YINGYONG SHENGXUE [APPLIED ACOUSTICS] in Chinese Vol 5 No 2, Apr 86  
pp 29-30

[Article by Lu Zhongnan [7120 6945 2809]. Yu Jiong [6735 3518] and Li Youzhi [2621 2589 1807] of Laboratory No 2, Institute of Acoustics, Nanjing University]

[Abstract] The article details the successful development of a surface acoustic wave, 63 chip bi-phase coded delay line with center frequency of 70 MHz, a coding rate of 5 M bits/sec, and a coding length of 12.6 ms. The coding contents from the 33rd to 63rd chip is a repetition of the coding sequence from the first to the 31st chip, thus composing an equivalent translation M<sub>32</sub> sequence. This coding delay line is developed for a certain signal processing format in realizing fast, precise synchronization of a time clock in a time division multiplex frequency-expansion communication system. Built on an ST quartz substrate, the device exhibits good temperature stability. Furthermore, to sufficiently exploit a series of advantages of the surface acoustic wave (SAW) device, different tuning-matching inductances were used in design while still allowing the insertion loss of the device to have an acceptable magnitude, in practice. As indicated in testing, the main performance indexes (the autocorrelation peak value and side lobe) are relatively close to the theoretical values. Good results were obtained in operations. The synchronization error is up to the 10 ns value while the signal amplitude of the expanded frequency has a variation of 4 dB in closed circuit tests with a coding rate of 5 M bits/sec and the secondary carrier wave of 70 MHz, thus satisfying the requirements in precise ranging. Four figures show the pulse response (of the device), its expanded waveform of reverse-phase point, and correlation waveforms of the first and intermediate code digits. The article was received for publication on 3 December 1984.

10424/12795  
CSO: 4009/74

Applied Lasers

OPTICAL MIXING AND ITS APPLICATION BASED ON SPIN-FLIP TRANSITIONS

Shanghai YINGYONG JIGUANG [APPLIED LASER] in Chinese Vol 6 No 2, Apr 86  
pp 53-58

[English abstract of article by Wang Weili [3769 1218 4409] of Beijing  
University]

[Text] Using a 5.3  $\mu\text{m}$  CO laser pump, a stimulated spin-flip Raman effect in the semiconductor InSb has been observed. Based on this effect, a tunable four-wave mixing process has been developed. Upon measurement of the spin-level splitting  $g^*$  factor, the value for  $x$  can be calculated in  $\text{Cd}_x\text{Hg}_{1-x}\text{Te}$  or other alloy semiconductors.

TAKING HIGH-SPEED PHOTOGRAPHY FOR REAL EXHAUST PLUMES OF ROCKET ENGINE WITH LASER TRANSIENT F-P INTERFEROMETER

Shanghai YINGYONG JIGUANG [APPLIED LASER] in Chinese Vol 6 No 2, Apr 86  
pp 59-62

[English abstract of article by He Anzhi [6320 1344 0037], et al., of the Physics Department, East China Institute of Technology]

[Text] This paper discusses the operational principles of a large aperture laser transient F-P interferometer. When using it to take high-speed photography for exhaust plumes of rocket engines, clear interferograms of the near-field structure of the rocket engine's real exhaust plume are obtained. The authors have obtained the mach disk location, boundary value and accident shock of the near-field structure in the exhaust plume from the interferograms. When compared with theoretical values, real experimental data is provided for the design of rocket engines and launchers.

PULSE-WIDTH-MODULATED GAS LASER POWER SUPPLY WITHOUT 50 HZ TRANSFORMER

Shanghai YINGYONG JIGUANG [APPLIED LASER] in Chinese Vol 6 No 2, Apr 86  
pp 69-72

[English abstract of article by Zhou Zhengyi [0719 2973 6146], et al., of  
Shanghai Institute of Laser Technology]

[Text] The author has made a constant current pulse-width-modulated gas laser power supply without a 50 Hz transformer which can attain the high current stability accuracy of 0.3 percent (full range). It has the advantages of good adaptability, multi-purpose use, small volume, light weight and is portable.

TUNABLE SINGLE MODE SEMICONDUCTOR LASER WITH EXTERNAL DISPERSIVE CAVITY

Shanghai YINGYONG JIGUANG [APPLIED LASER] in Chinese Vol 6 No 2, Apr 86  
pp 73-77

[English abstract of article by Zhou Binkun [0719 3521 3824], et al., of the  
Department of Radio Electronics, Qinghua University]

[Text] It has been reported that a tunable single mode semiconductor laser with an external dispersive cavity has been made based on experimental projects. Its linewidth is less than 50 MHz. The stable time of the single mode is more than 20 min. The output power is more than 1 mW (influenced by the structure of the heat sink of the solitary diode) and the tunable range is more than 200 Å.

STUDIES OF PHOTOCONDUCTIVITY AND SWITCH PROPERTIES OF AMORPHOUS SILICON  
USING NS PULSE LASER

Shanghai YINGYONG JIGUANG [APPLIED LASER] in Chinese Vol 6 No 2, Apr 86  
pp 78-80

[English abstract of article by Ma Yurong [7456 3768 5554], et al., of the  
Department of Physics, University of Science and Technology of China]

[Text] The steady state and transient photoconductivity has been investigated by using an He-Ne laser and a ns pulse laser as excitation sources. The switching effect of amorphous silicon has also been studied for the first step. It has been found that the steady state photoconductivity varies with excitation intensity, showing an exponential law. The rise and decay time of transient photoconductivity is of the order of magnitude of  $\mu\text{s}$  and decreases with an increase in excitation intensity, but is independent of the electric field applied.

9717  
CSO: 4009/79

Astronomy

ON THE PROBLEM OF CRITICAL INCLINATION AND COMMENSURABILITY IN THE MOTION OF ARTIFICIAL SATELLITES

Beijing TIANWEN XUEBAO [ACTA ASTRONOMICA SINICA] in Chinese Vol 27 No 1, Mar 86 pp 1-8

[English abstract of article by Liu Lin [0491 2651] of the Department of Astronomy, Nanjing University; and K.A. Innanen of the Physics Department, York University, Toronto, Ontario, Canada]

[Text] The resonant problem resulting from the critical inclination and commensurability in the motion of an artificial satellite is discussed. Considering the non-spherical perturbation of the earth for the averaged model, the quality of the equilibrium solution and the corresponding libration region are given. Finally, we compare this solution with the actual motion of an artificial satellite. We find that the resonance plays a stabilizing role in the motion and that the luni-solar perturbations have a significant effect on the orbital resonance of 24-h synchronous satellites.

IMPROVEMENT OF IMAGE QUALITY OF SPHERICAL LENS CORRECTOR FOR CASSEGRAIN TELESCOPE

Beijing TIANWEN XUEBAO [ACTA ASTRONOMICA SINICA] in Chinese Vol 27 No 1, Mar 86 pp 80-84

[English abstract of article by Yi Meiliang [5056 5019 5328], et al., of Nanjing Astronomical Instrument Factory, Chinese Academy of Sciences]

[Text] In a previous work excellent results were obtained by using a spherical lens corrector for the Cassegrain telescope. In the optimization processes, the thicknesses of the lenses and the secondary mirror position were taken as constants.

We think that usable results with much better image quality can be obtained if the thicknesses of the lenses and the secondary mirror position are taken as variables optimizing with other parameters. In this paper an example is given to demonstrate this idea. A spherical 2-lens corrector made of fused quartz for the Ritchey-Chretien (R-C) telescope is selected for comparison. By adding the above-mentioned two type variables, we re-optimize this system, obtaining the expected results. It is obvious that the improvement of the image quality is greater, especially the chromatic difference of the image. We think that this idea (even adding the changing of the tertiary mirror position if it exists in the telescope) may apply to any corrector for various types of telescopes.

For convenience and utility possibilities, two other configurations are enumerated in the tables. The image quality, lens thickness and secondary mirror position are studied.

9717  
CSO: 4009/82

Chemistry

GENERAL DATA PROCESSING OF SPECTROPHOTOMETRIC METHOD FOR COORDINATION  
NUCLEOPHILIC SYSTEM IN SOLUTION OF MONONUCLEAR COMPLEX

Shanghai HUAXUE XUEBAO [ACTA CHIMICA SINICA] in Chinese Vol 43 No 12, Dec 85  
pp 1145-1150

[English abstract of article by Han Weiping [7281 4850 1456] of Northeast  
Petrochemical Institute, Harbin; and Sun Xuezhong [1327 1331 1813], et al.,  
of Daqing Petroleum Institute, Daqing]

[Text] An improved data processing method for the coordination nucleophilic  
substitution reaction between two kinds of ligands of mononuclear complexes  
by spectrophotometric method is proposed. This processing method can be  
applied to the visible and ultraviolet regions of  $MZ_i$  and  $ML_j$ .

Experimental data measured by the UV spectrophotometric method for the  
competing system are as follows:

$ZnY^{2-}$	$\beta_1 = 1.63 \times 10^7$	$\epsilon_1 = 2.21 \times 10^5$ (212 nm)
$FeC_2O_4^+$	$\beta_1 = 2 \times 10^3$	$\epsilon_1 = 2.5 \times 10^4$ (216 nm)
$Fe(C_2O_4)_2^-$	$\beta_2 = 4.5 \times 10^7$	$\epsilon_2 = 5.4 \times 10^4$ (216 nm)

(Paper received 3 October 1984.)

REFERENCES

- [1] Якимирский, К. Е., *Ж. неорг. хим.*, 1956, 1, 2306; 何钟林, 刘祁涛, *化学学报*, 1963, 29, 58.
- [2] 韩维屏, *科学通报*, 1964, 3, 242.
- [3] 韩维屏, *科学通报*, 1966, 1, 28.
- [4] Poulsen, K. G.; Bjerrum, J.; Poulsen, J., *Acta Chem. Scand.*, 1954, 8, 921.
- [5] Sillen, L. G.; Martell, A., "*Stability Constants of Metal-Ion Complexes*", 2ed, The Chemical Society, London, 1964; Supplement (1), 1971.
- [6] 孙羊忠, 姜公和, 鲁怀虎, 汪颖军, 韩维屏, *化学通报*, 1985 (1), 15.

## <sup>15</sup>N NMR STUDY OF SILATRANES

Shanghai HUAXUE XUEBAO [ACTA CHIMICA SINICA] in Chinese Vol 43 No 12, Dec 85 pp 1151-1154

[English abstract of article by Zhu Jinchang [2612 2516 2490], et al., of the Institute of Photographic Chemistry, Chinese Academy of Sciences; and Chen Bangqin [7115 6721 2953], et al., of the Institute of Chemistry, Chinese Academy of Sciences]

[Text] Various silatrane compounds were studied by means of <sup>15</sup>N NMR spectroscopy. The quantum chemical calculations of some of the compounds were carried out using CNDO/2 method. The following correlations were obtained: <sup>15</sup>N chemical shifts vary linearly with Taft's polar substituent constants  $\sigma^*(s)$  of the substituents R on the silicon atoms, and also with the net electronic densities on the nitrogen atoms. From both experimental and theoretical results it can be concluded that the Si-N dative bonds in a series of silatrane compounds actually exist. (Paper received 15 October 1984.)

### REFERENCES

- [1] Воронков. М. Г.; Дьяков. В. М., "Силатраны", Издательство Наука, Москва, 1978.
- [2] Voronkov. M. G., *Pure Appl. Chem.*, 1986, 13, 35.
- [3] Parkanyi. L.; Simon. K.; Nagy. J., *Acta Crystallogr. sect B*, 1974, 30, 2328.
- [4] Parkanyi. L.; Bihatsi. L.; Hencsei. P., *Cryst. Struct. Commun.*, 1978, 7, 485.
- [5] Кемме. А. А.; Блейделис. Я. Я.; Дьяков. В. М.; Воронков. М. Г., *Журнал структурной химии*, 1975, 16, 914.
- [6] Кемме. А. А.; Блейделис. Я. Я.; Пестунович. В. А.; Барышок. В. П.; Воронков. М. Г., *Доклады Академии Наук СССР* 1978, 243, 688.
- [7] 王守道, 胡宁海, *中国科学(B)*, 1983, 7, 595.
- [8] 滕脉坤, 吴治新, 吴观丽, *结构化学*, 1983, 2, 281.
- [9] 王守道, 胡建国, *科学通报*, 1981, 26, 603.
- [10] Harris. B. K.; Jones. J.; Ng. S., *J. Magn. Reson.*, 1978, 30, 521.
- [11] 徐广智, 李二成, 鲁开娟, 吴治新, 吴观丽, 陈星綵, *科学通报*, 1985, 30, 40.
- [12] 方一革, 胡淑蔚, 吴观丽, 徐梦山, *化学学报*, 1983, 41, 630.
- [13] 王殿勋, 张大仁, 鲁开娟, 吴治新, 吴观丽, *中国科学(B)*, 1982, 26, 875.
- [14] Tacke. R.; Wannagat. U., *Topics in Current Chemistry*, 1979, 34, 16.
- [15] Zhu J. -C.; Wu H. -J.; Jiang L. -J.; Martin. G. J.; Chen B. -Q.; Wu G. -L.; Lai Z. -G., *J. Chim. Phys.*, 1984, 81, 407.
- [16] 朱晋昌, 孙贤育, 伍华菊, 蒋丽金, 陈邦钦, 鲁开娟, 吴观丽, *中国科学(B)*, (待发表).
- [17] Pople. J. A.; Beveridge. D. L., "Approximate Molecular Orbital Theory", McGraw-Hill, London, 1970.
- [18] Newman. M. S. (Ed.), "Steric Effect in Organic Chemistry", Chapt. 18, John Wiley & Sons, Inc., New York, 1956.

STUDIES OF ORGANOSILICON COMPOUNDS WITH BIOLOGICAL ACTIVITY. IV. ON THE 2,2-DISUBSTITUTED-3-ALKYL-1-OXA-3-AZA-2-SILACYCLOHEXEN-4-ONE

Shanghai HUAXUE XUEBAO [ACTA CHIMICA SINICA] in Chinese Vol 43 No 12, Dec 85 pp 1207-1211

[English abstract of article by Wang Minde [3769 2494 1795], et al., of the Institute of Elemento-organic Chemistry, Nankai University, Tianjin]

[Text] A series of organosilicon compounds, 2,2-disubstituted-3-alkyl-1-oxa-3-aza-2-sila-cyclohexen-4-one, has been synthesized from the reaction of N-alkyl salicylic amide with  $R^1R^2SiCl_2$  or  $R^1R^2Si(OEt)_2$ . According to the spectroscopic evidence, these compounds exist in keto-form in agreement with our previous findings. (Paper received 22 November 1984.)

REFERENCES

- [1] 谢庆兰, 张增佑, 有机化学, 1984, 187.
- [2] Coates, L. V.; Drain, D. J.; Kerridge, K. A.; Macrae, F. J.; Tattersall, K., *J. Pharm. Pharmacol.*, 1957, 9, 855.
- [3] Kralt, T.; Moed, H. D.; Ariens, E. J.; Hendriksen, T. W. J., *Rec. Trav. Chim.*, 1959, 78, 207.
- [4] Tanner, D. W.; Bruice, T. C., *J. Am. Chem. Soc.*, 1967, 89, 6954.
- [5] Morris, L. B., U. S. 3 780 080, 1973.
- [6] Ismail, B., M.; Bessler, E., *J. Organomet. Chem.*, 1968, 13, 253.
- [7] 杨石先, 陈其杰, 王明德, 吴仲, 董贻诚, 中国科学 B 辑, 1984, 6, 496.
- [8] 王明德, 谢庆兰, 张增佑, 廖仁安, 化学学报, 1985, 43, (10)
- [9] Clinton, B. O.; Laskowski, S. C., *J. Am. Chem. Soc.*, 1948, 70, 3135.
- [10] Sheinmann, F., *An Introduction to Spectroscopic Methods for the Identification of Organic Compounds* Vol. 2, Pergamon Press, New York, 1974, p. 47.
- [11] Chamberlain, N. F., *The Practice of NMR Spectroscopy with Spectra-Structure Correlations for Hydrogen-1* Plenum Press, New York, 1974, p. 125.
- [12] 蒋尚信, 沈美霞, 陈美华, 尚若莹, 金瑚珍, 徐光漪, 化学学报, 1984, 42, 929.

9717

CSO: 4009/1048

Electronics

STUDY OF POLYGONAL MICROSTRIP ANTENNAS

Beijing DIANZI XUEBAO [ACTA ELECTRONICA SINICA] in Chinese Vol 13 No 6,  
Nov 85 pp 1-4

[English abstract of article by Cai Juliang [2580 5468 5328], et al., of Shanghai Jiaotong University; and Li Wenxiang [2621 2429 4382] of Shanghai 1051 Research Institute]

[Text] A solution to the characteristic parameters of polygonal microstrip antennas is investigated by the conformal outermapping method. The outside area parameters of a polygonal microstrip antenna are transformed into the corresponding ones of a circular microstrip antenna first, then transformed inversely into the boundary values of a polygonal antenna. Thus the solution of polygonal microstrip antennas is obtained. The theoretical and experimental results are in agreement. (Paper received in October 1984; finalized in May 1985.)

REFERENCES

- [1] K. R. Carver; and E. L. Coffey: Theoretical Investigation of the Microstrip Antenna, PT-00929, Physical Science Laboratory, New Mexico State Univ., Jan. 1979.
- [2] H. D. Weinschel: A Cylindrical array of circularly polarized microstrip antennas, IEEE AP-S Int. Symp. Digest, 1975, pp.177-180.
- [3] Cao Ju-Liang (曹菊良): Radiation field of tapered slotline antenna, IEEE AP-S Int. Symp. Digest, 1984, pp.90-93.
- [4] N. G. Alexopoulos et al: Radiation by microstrip patches, IEEE AP-S Int. Symp. Digest, 1979.
- [5] R. E. Collin, F. J. Zucker: Antenna Theory, Part 1, McGraw Hill Book Co., N. Y., 1969.
- [6] K. R. Carver, J. W. Mink: Microstrip antenna technology, IEEE Trans., Vol. AP-29, pp.2-24, 1981.
- [7] P. K. Agrawal, M. C. Bailey: An analysis technique for microstrip antenna, IEEE Trans., Vol. AP-25, pp.756-759, 1977.
- [8] S. A. Long et al.: Theory of the circular-disk printed-circuit antenna, Proc. IEE, Vol. 125, pp.925-928, 1978.
- [9] A. G. Derneryd: Analysis of the microstrip disk antenna element, IEEE Trans., Vol. AP-27, pp.660-664, 1979.
- [10] K. C. Gupta, et al.: Microstrip Lines and Slotline, Dedham, Mass. Artech House, 1979, Chapter 2.
- [11] T. C. Edwards, R. P. Owens: 2-18GHz dispersion measurements on 10-100 Ohm microstrip line on sap-phire, IEEE Trans, Vol. MTT-24, pp.506-513, 1976.
- [12] E. H. Newman, P. Tulyathan: Analysis of microstrip antenna using moment methods, IEEE Trans., Vol. AP-29, pp.47-53, 1981.

## H-ALGORITHM AND ITS VALIDITY

Beijing DIANZI XUEBAO [ACTA ELECTRONICA SINICA] in Chinese Vol 13 No 6, Nov 85  
pp 5-12

[English abstract of article by Ruan Genhong [7086 2704 7703], et al., of  
Fudan University, Shanghai]

[Text] The H-algorithm for test generation of asynchronous circuits is discussed and its validity is proved. A program HALG based on the H-algorithm is developed on a PDP-11/23 computer, and test sequences are generated for some circuits. The results are consistent with the theoretical analysis. (Paper received in March 1984; finalized in May 1985.)

### REFERENCES

- [1] 阮根鸿, 异步时序电路测试生成法——H算法, 电子学报, No.1, pp.40—57, 1983.
- [2] 阮根鸿, 六值模拟, 电子学报, No.2, pp.24—31, 1981.
- [3] J. S. Jephson et al.: Three-value computer design verification system. IBM system Journal, Vol.8, No.3, pp.179—189, 1969.
- [4] C. W. Cha et al.: g-V algorithm for test pattern generation of combinational digital circuits, IEEE Trans., Vol. C-27, pp.193—200, 1978.

## FAST DIAGNOSIS ALGORITHM FOR MULTIPLE FAULTS IN PARITY CHECK CIRCUITS

Beijing DIANZI XUEBAO [ACTA ELECTRONICA SINICA] in Chinese Vol 13 No 6, Nov 85  
pp 19-25

[English abstract of article by Xu Xingning [1776 2502 1337] of the Beijing  
Institute of Posts and Telecommunications]

[Text] A simple and efficient algorithm for locating multiple faults in parity check circuits is presented. It is based on a new concept called "Minority Bit," and the fault location test set so obtained is optimal. The length of the test sequence is equal to the number of primary inputs plus one. The implementation of automatically generating the optimal test set and quickly locating all the faults is also discussed. (Paper received in October 1984; finalized in February 1985.)

### REFERENCES

- [1] 王尔乾: 中大规模集成电路, 国防工业出版社, 1981.
- [2] D. C. Bossen, D. L. Ostapko and A. M. Patel: Optimum Test Patterns for Parity Networks, Proc. Fall Joint Comput. Conf., 1970.
- [3] Se June Hong and D. L. Ostapko: A Simple Procedure to Generate Optimum Test Patterns for Parity Logic Networks, IEEE Trans., Vol. C-30, No.5, May, 1981.
- [4] Xingning Xu and E. J. McCluskey: Test Generation and Fault Diagnosis for Multiple Faults in Combinational Circuits, Digest, FTCS-13, Milano, Italy, June, 1983.

## ACTIVE FILTER USING OPERATIONAL AMPLIFIER POLE

Beijing DIANZI XUEBAO [ACTA ELECTRONICA SINICA] in Chinese Vol 13 No 6, Nov 85  
pp 26-30

[English abstract of article by Peng Shuizhen [1756 3055 6297] of Chengdu  
Institute of Radio Engineering, Sichuan]

[Text] A new active filter circuit with one operational amplifier, one capacitor and several resistors is presented. The operational amplifier pole is utilized. The circuit can fulfill the second-order lowpass, highpass, bandpass, band-stop and allpass functions. As a band-stop filter, not only can the  $\omega_0$  and Q be adjusted independently, but the band-stop attenuation can also be adjusted. Design examples and experimental results are given. (Paper received in June 1984; finalized in November 1984.)

### REFERENCES

- [1] A.M. Soliman, M. Fawzy: Some partially active R filter circuits, The Radio and Electronic Engineer, Vol. 49, No. 11, pp. 587-590, Nov. 1979.
- [2] 彭水贞: 有源R带阻滤波器, 电子学报, Vol-10, No. 1, pp. 84-88. 1982.
- [3] M.S. Ghauri, K.R. Laker: Modern Filter Design: Active RC and Switched Capacitor, Prentice-Hall, Inc., p.264, 1981.

## LIFETIME LIMITATION OF FRONT-ILLUMINATED EBS-CCD

Beijing DIANZI XUEBAO [ACTA ELECTRONICA SINICA] in Chinese Vol 13 No 6, Nov 85  
pp 54-57

[English abstract of article by Chen Zhongmou [7115 6988 6180], et al., of  
Zhongshan Institute of Electronics, Nanjing]

[Text] Based on fundamental research into the electron irradiation degradation mechanism of the front-illuminated EBS-CCD, different factors affecting its lifetime limitations are analyzed. Several practical ways to increase the lifetime are given. Experimental results are in good agreement with theoretical predictions. (Paper received in February 1984; finalized in September 1984.)

### REFERENCES

- [1] J. Cheng et al.: AD AO82603.
- [2] 陈钟谋, 张吉登: 电子科学, No. 3, p. 45, 1982.
- [3] J. M. Aitken, D. R. Young: J. Appl. Phys., Vol. 47, No. 3-4, p. 1196, 1976.
- [4] C. W. Gwyn: J. Appl. Phys., Vol. 40, No. 12, p. 4886, 1969.
- [5] 江丕桓等: 场效应晶体管及其集成电路, 国防工业出版社, 1974年。
- [6] C. P. Chang: IEEE Trans., Vol. NS-23, p. 1639, 1976.
- [7] C. P. Chang: IEEE Trans., Vol. NS-24, p. 2190, 1977.
- [8] M. S. Cohen, J. S. Moore: J. Appl. Phys., Vol. 45, No. 12, 1 p. 5335, 1974.
- [9] R. L. Gordan: Appl. Optics, Vol. 15, No. 8, p. 1909, 1976.

## COMPUTER SIMULATION FOR PROBLEM OF FREQUENCY STABILITY IN MODERN ELECTRONIC SYSTEMS

Beijing DIANZI XUEBAO [ACTA ELECTRONICA SINICA] in Chinese Vol 13 No 6, Nov 85  
pp 58-64

[English abstract of article by Guo Yanying [6753 5888 3853] of Beijing  
Institute of Radio Metrology and Measurements]

[Text] The Monte-Carlo computer simulation is presented in solving the problem of frequency stability in modern electronic systems. Its first key procedure is generating a high quality random sequence simulating the oscillator phase noise, followed by calculation of the response of the system (mathematical model) with this random sequence on the computer. After that, the required statistical estimation can be obtained. The method for designing random sequences is discussed in detail. Finally, two examples--synthetic aperture radar and Doppler velocity measuring system--are given to clarify the realization of computer simulation and illustrate its versatility. (Paper received in June 1984; finalized in November 1984.)

### REFERENCES

- [1] 郭衍莹, 宇航学报, 1981年第4期, 第11页。
- [2] 郭衍莹等, 空间跟踪和通信用地面发射机系统设计, 第一章, 国防工业出版社(即将出版)。
- [3] D. E. Knuth: The Art of Computer Programming, Vol. 2, p. 78, McGraw-Hill, New York, 1974.
- [4] 冯康, 数值计算方法, 国防工业出版社, 1978年。
- [5] 刘宜伦等, 网络综合理论, 人民邮电出版社, 1962年。
- [6] E. S. Kuh: Principles of Circuit Synthesis, McGraw-Hill, New York, 1950.
- [7] C. A. Green: IRE Trans., Vol. MIL-6, p. 130, April, 1962.

## ADJOINT-NETWORK METHOD FOR INCREMENTAL ANALYSIS

Beijing DIANZI XUEBAO [ACTA ELECTRONICA SINICA] in Chinese Vol 13 No 6, Nov 85  
pp 72-79

[English abstract of article by Ling Xieting [0407 3610 0080] of Fudan  
University, Shanghai]

[Text] The circuit tolerance design and fault analysis usually demand the knowledge of circuit properties while the elements are getting incremental changes. The adjoint-network method may give differential sensitivities efficiently, but it cannot be used in incremental situations and nonlinear circuits directly. The extension of this method is discussed. (Paper received in May 1984; finalized in January 1985.)

### REFERENCES

- [1] H. W. Bode: Network Analysis and Feedback Amplifier Design, D. Van Nostrand Co. Inc., Princeton, N. J., 1945.
- [2] B. J. Karafin: BSTJ, Vol. 50, p. 1225, 1971.
- [3] S. W. Director, G. D. Hachtel: IEEE Trans., Vol. CAS-24, No. 7, p. 383, 1977.
- [4] 凌燮亭, 潘明德, 电路最优化中心设计的一个新算法, 复旦大学学报(自然科学版), 第21卷, 第3期, 第307页, 1982年。
- [5] S. Skelboe: IEEE Trans., Vol. CAS-26, p. 874, 1979.
- [6] T. N. Trick, C. J. Alajajian: Fault analysis of analog circuits, Proc. 20th Midwest Symposium on Circuits and Systems, p. 211, 1977.
- [7] Z. F. Huang, C. S. Lin, R. Lin: Node-fault diagnosis and design of testability, 20th IEEE Conference on Decision and Control, p. 1037, 1981.
- [8] R. Lin: Analog fault diagnosis: A new circuit theory, Proc. 1983 IEEE Int. Symp. on Circuits and Systems, p.931.
- [9] 凌燮亭, 非线性电路的故障分析, 电子学报, No.1, p. 70, 1981.
- [10] L. O. Chua, P. M. Lin: Computer Aided Analysis of Electronic Circuits, Pentice-Hall.
- [11] G. C. Temes: Efficient methods of fault simulation, Proc. 20th Midwest Symp. on Circuits and Systems, part I, p.191, 1977.
- [12] S. R. Parker: Sensitivity, old questions, some new answer, IEEE Trans., Vol. CT-18, p.27, 1971.
- [13] 凌燮亭, 模拟电路中有限故障数的预测-判定分析方法, 电子学报, No.3, p.37, 1982.
- [14] T. N. Trick, Y. Li: Proc. 1983 IEEE Int. Symp. on Circuit and Systems, p. 1098.

DISTRIBUTION FUNCTION OF SIGNAL-TO-NOISE RATIOS FOR NON-EQUAL MEDIAN SIGNAL  
PREDETECTION OPTIMUM DIVERSITY COMBINING

Beijing DIANZI XUEBAO [ACTA ELECTRONICA SINICA] in Chinese Vol 13 No 6, Nov 85  
pp 91-99

[English abstract of article by Luo Zhengbin [7482 2973 1755] of the  
Shijiazhuang Communication Laboratories, Hebei]

[Text] The expressions of probability density and distribution functions of  
signal-to-noise ratios for non-equal median signal predetection optimum  
diversity combining are given and some computing results are also presented.  
(paper received in June 1984; finalized in December 1984.)

REFERENCES

- [1] D. G. Brennan: Linear diversity combining techniques, PIRE, No. 6, pp. 1075~1102, 1959.
- [2] W. B. Davenport, Jr. and W. L. Root: Introduction to Random Signals and Noise, McGraw-Hill, New York, 1958.
- [3] André Angot. 陆志刚等译校, 电工电信工程师数学(上册), 人民邮电出版社, 1979年。

9717

CSO: 4009/1051

## Optics

## SURFACE-ENHANCED RAMAN SPECTRA OF O-PHENANTHROLINE, 2, 2'-BIPYRIDINE AND THEIR COMPLEX IONS ADSORBED ON SILVER COLLOID

Shanghai GUANGXUE XUEBAO [ACTA OPTICA SINICA] in Chinese Vol 6 No 4, Apr 86  
pp 298-306

[English abstract of article by Zhang Chunping [1728 2504 1627], et al., of  
the Department of Physics, Nankai University, Tianjin]

[Text] SERS from O-phenanthroline, 2, 2'-bipyridine and their complex ions adsorbed on colloidal silver particles have been observed for the first time. The results provide experimental evidence for the opinion that the  $200\text{ cm}^{-1}$  band is related to the N-Ag bond vibration. Comparisons between Raman spectra of the molecules and those of their complexes are made, and some new phenomena are found. Combined with other experimental results (electron microscope photograph, transmission spectra), analyses and explanations are given for these phenomena.

SPECTROSCOPIC PARAMETERS OF  $\text{Er}^{3+}$  CRYSTALS CALCULATED BY JUDD-OFELT THEORY

Shanghai GUANGXUE XUEBAO [ACTA OPTICA SINICA] in Chinese Vol 6 No 4, Apr 86  
pp 307-313

[English abstract of article by Wang Qingyuan [3769 1987 0337], et al., of  
Changchun Institute of Applied Chemistry, Chinese Academy of Sciences]

[Text] In this paper we report the results of spectroscopic intensity parameters of  $\text{Er}^{3+}$  in  $\text{YAG}:\text{Er}^{3+}$  single crystals. By using absorption spectra and Judd-Ofelt theory the experimental and theoretical oscillator strengths have been calculated. The rms deviation is only  $1.9 \times 10^{-7}$ . Based on a least-square fit between the experimental and theoretical oscillator strengths, the intensity parameters have been determined. The results are  $\Omega_2 = 0.19 \times 10^{-20} \text{ cm}^2$ ;  $\Omega_4 = 1.68 \times 10^{-20} \text{ cm}^2$ ;  $\Omega_6 = 0.62 \times 10^{-20} \text{ cm}^2$ . We then calculated the probabilities of the induced electric and magnetic dipole spontaneous radiative transitions radiative lifetimes, high oscillator strengths and branching ratios. The fluorescence spectra of  $\text{Er}^{3+}$  in  $\text{YAG}:\text{Er}^{3+}$  crystals were shown to be in the  $0.3 \mu\text{m} \sim 2.0 \mu\text{m}$  wave length range.

MODULATED PHOTOELECTRIC SPONTANEOUS MAGNETIC FIELD IN A LASER PLASMA

Shanghai GUANGXUE XUEBAO [ACTA OPTICA SINICA] in Chinese Vol 6 No 4, Apr 86  
pp 314-319

[English abstract of article by Zhu Shitong [2612 5535 6639] of Shanghai  
Institute of Optics and Fine Mechanics, Chinese Academy of Sciences; SHEN Wenda  
[3088 2429 6671] of the Department of Physics, Shanghai University of Science  
and Technology]

[Text] The spontaneous magnetic field associated with photoelectric effects  
in a laser plasma is studied. The analytic solution for the spontaneous  
magnetic field temporarily and spatially modulated under the oblique  
incidence of s-polarized light into a static isothermal plasma is obtained.

STUDY OF A RING DYE LASER WITH COLLIDING PULSE MODE-LOCKING

Shanghai GUANGXUE XUEBAO [ACTA OPTICA SINICA] in Chinese Vol 6 No 4, Apr 86  
pp 320-325

[English abstract of article by Wang Qingyue [3769 3237 2588], et al., of  
the Department of Precision Instrument Engineering, Tianjin University]

[Text] This paper presents results of a study of a ring dye laser which is  
colliding pulse mode-locked. The relationship between the concentration of  
DODCI, pumping power and pulse width is summarized here. A nearly transform-  
limit pulse width of 90 fs has been obtained.

ANALYSIS OF A QUASI-CW PUMPED INTRACAVITY FREQUENCY DOUBLING YAG LASER AND ITS THERMAL EFFECT

Shanghai GUANGXUE XUEBAO [ACTA OPTICA SINICA] in Chinese Vol 6 No 4, Apr 86 pp 326-331

[English abstract of article by Yao Jianquan [1202 1696 6898], et al., of the Department of Precision Instrument Engineering, Tianjin University]

[Text] From the theory of SHG of Gaussian-like beams, we come to the conclusion that the power of the second-harmonic wave is approximately proportional to the square of the fundamental wave power for frequency doubling of Gaussian-like beams with high conversion efficiencies. Based on this, a new intracavity frequency doubling scheme of a mixing-mode beam, i.e., quasi-CW pumping, is proposed. By using such a scheme, the output power can be increased by a factor of two, a fact that has been proven by theory and experiments. From the thermal conduction equation, it has been found that the beam propagation parameter through a YAG rod under quasi-CW pumping is 22 percent lower than that under CW pumping. If other factors are taken into account, the decrease will become 30 percent. By experimental measurements, we find that the thermal focal length is increased and the divergence angle is decreased, as predicted by theory.

SINGLE LONGITUDINAL MODE CHARACTERISTICS OF SHORT-COUPLED-CAVITY (SCC)  
SEMICONDUCTOR LASERS

Shanghai GUANGXUE XUEBAO [ACTA OPTICA SINICA] in Chinese Vol 6 No 4, Apr 86  
pp 332-338

[English abstract of article by Zhou Bingkun [0719 3521 3824], et al., of  
the Department of Radio Electronics, Qinghua University, Beijing]

[Text] By introducing an additional loss parameter for the description of SCC and developing a model of modified multimode rate equations, the mode selection mechanism and characteristics of SCC semiconductor lasers have been investigated theoretically. It is found that an antireflection coating on the end facet of a laser diode is necessary for high-quality single longitudinal mode operation. Based on the theoretical results, a new type of miniature SCC laser has been constructed and demonstrated. Single mode outputs with 35~40 dB side mode suppression ratios have been obtained under CW and 150 MHz modulation conditions.

THEORY OF LASER BEAM DISPLACEMENT IN TURBULENT ATMOSPHERE

Shanghai GUANGXUE XUEBAO [ACTA OPTICA SINICA] in Chinese Vol 6 No 4, Apr 86  
pp 373-380

[English abstract of article by Zhang Yixin [1728 6654 2450], et al., of  
Anhui Institute of Optics and Fine Mechanics, Chinese Academy of Sciences,  
Hefei]

[Text] The displacement of a spatially partial coherent light beam propagating  
through the turbulent atmosphere has been studied by assuming Gaussian  
distribution of the wave complex amplitude. The formula for the beam dis-  
placement was obtained, and it agrees with experimental data in both weak and  
strong intensity fluctuation regions.

9717

CSO: 4009/78

Physics

HEAVY-FERMION SYSTEM AND ITS SUPERCONDUCTIVITY

Beijing WULI [PHYSICS] in Chinese Vol 15 No 1, Jan 86 pp 7-9, 60

[Article by Zhang Liyuan [4545 4539 3293], Department of Physics, Beijing University]

[Abstract] Since the discovery of superconductivity in the heavy-fermion system  $\text{CeCu}_2\text{SiO}_2$  in 1979 by F. Steglich et al. (West Germany), up to now three of the eight discovered heavy-fermion systems have been shown to exhibit superconductivity characteristics. Experimental physicists in a number of countries paid great interest to the heavy-fermion system and its superconductivity, as new research subjects are being proposed: why do electrons of the fermion system have such a large effective mass? Which superconductivity characteristics differ from those propounded in the BCS theory? Is there any new superconductivity mechanism? At present, there are two views as to the theory. One view holds that the fundamental regime of BCS superconductivity is still valid. Another view holds that the superconductivity feature of the heavy-fermion system is similar to the superfluid state of  $^3\text{He}$  in its A and B phases, since the electron pairing spin is in the triplet state with total spin equal to 1. Further intensive experiments and theoretical research are required. Two tables show the following parameters of heavy-fermion systems: interatomic distance, magnetic susceptibility and specific heat of electrons. Three figures show relationships between the functions of specific heat and temperature, as well as the apparent inconsistency between electron specific heat and the results of the BCS theory when  $\text{CeCu}_2\text{Si}_2$  and  $\text{UBe}_{13}$  are in the superconductivity state.

10424/9190  
CSO: 4009/61

## LIQUID CRYSTAL COLOR DISPLAY

Beijing WULI [PHYSICS] in Chinese Vol 15 No 1, Jan 86 pp 43-47, 19

[Article by Hong Xijun [3163 3356 0689], Shanghai Institute of Organic Chemistry, Chinese Academy of Sciences]

[Abstract] In the 1970's, LCD (liquid crystal displays) developed rapidly due to their unique operational features of low voltage and low power consumption; in particular, the TN field effect monochrome display has been widely commercialized. Like the monochrome display, the liquid color display employs variation of arrangement in liquid crystal molecules (after an electric field is imposed), thus changing the optical characteristics of the liquid crystal container. The GH type color display with the dichroic mode produces a unique, sharp color with high brightness and wide visual angle; thus, research on GH color displays is the most active. Some problems remain to be solved before its commercialization: positive display, matrix display and extended service life of these GH type devices. The article presents the operating principle and the related problems of liquid crystal color displays with emphasis on the dichroic mode. It is predicted that there will be faster development in applications of color LCD in automation instruments, motor vehicles, industrial equipment and consumer goods with the development of better liquid crystals and dyes as well as the use of new techniques. Liquid crystal television will be commercialized with a higher performance-to-price ratio, and in portable information systems. One table shows the operational mode and characteristics of the GH type in its electrooptical effect. Four figures show the absorption characteristics of positive and negative type dyes, the operating principle of the GH type color display, positive-type display GH container, and phase-change Gh type display.

10424/9190  
CSO; 4009/61

#### ION MIXING TO PRODUCE AMORPHOUS ALLOY THIN FILMS

Beijing WULI [PHYSICS] in Chinese Vol 15 No 2, Feb 86 pp 91-96

[Article by Liu Baixin [2692 4102 2450] and Ma En [7456 1869] of the Department of Engineering Physics, Qinghua University]

[Abstract] This article presents the ion beam method (blending of ion migration and ion beam) as a new, unique method, stressing the experimental results and rules reached in recent years by the authors and their research team on ion mixing synthesis of amorphous alloys. As proposed by the authors, an equilibrium phase diagram is used to predict rules and models for the formation of amorphous alloys by ion beam mixing. The article also comprehensively introduces and evaluates research results in other countries on this subject. Two tables list the binary (metal) systems studied and the amorphous alloys formed, including more than 10 binary metal systems studied by the authors and their research team. The measured crystallization temperatures are also given in one of the tables for some of the amorphous alloys produced. Three figures show a typical electron diffraction picture of Ni-Mo amorphous alloy, a formation diagram for certain amorphous alloys, and an alloy phase formation diagram during ion beam mixing corresponding to a typical equilibrium phase diagram. For the first time, the authors produced amorphous Mo-Ru superconducting thin films (with quite good superconductivity characteristics) in which third metals were not added. With their magneto-optical features, these amorphous films can be used in fabricating optical data storage media. Therefore, the authors selected magnetic materials as Gd, Fe, Co and Tb, among other metals, to be combined into binary or even multiple metals in order to gain the advantages of blending into small but controllable quantities of amorphous thin films with several constituents, after blending experiments.

#### A MEDIUM POWER NONHELIUM LONG LIFE-SPAN TEACO<sub>2</sub> LASER

Beijing WULI [PHYSICS] in Chinese Vol 15 No 2, Feb 86 pp 105-106

[Article by Lu Huibin [0712 1920 6333], Zhou Yueliang [0719 1471 0081], Cui Daju [1508 1129 1788], Guo Shuping [6753 2579 1627] and Hou Jianhua [0186 1696 5478] of the Institute of Physics, Chinese Academy of Sciences]

[Abstract] The TEACO<sub>2</sub> laser has important applications in laser chemistry, laser isolation of isotopes, laser physics and national defense, among other fields. The authors reported on the nonhelium long service-life repetition

frequency TEACO<sub>2</sub> laser. In a number of research areas, relatively high values of average power and repetition frequency are required in a laser; therefore, the authors developed the TEACO<sub>2</sub> laser with intermediate (average) power. In a single operating session, the laser output energy is 10 J, with an average power of more than 80 W. When the relative humidity is below 85 percent, the laser is capable of maintaining nonhelium continuous extended-service steady operation for a repetition frequency within the range between a single operation and 30 operations per second. The profile of the laser structure is as follows:

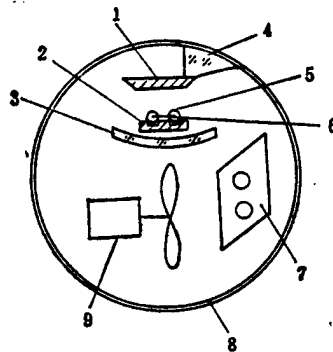

Key:

- |                       |                             |
|-----------------------|-----------------------------|
| 1. Anode              | 6. Pre-ionization electrode |
| 2. Cathode            | 7. Water cooler             |
| 3. Lower stream guide | 8. Outer shell              |
| 4. Upper stream guide | 9. Blower fan               |
| 5. Pressure plate     |                             |

Two other figures show the relationship between laser energy and voltage, and the waveform of laser pulses when CO<sub>2</sub>:N<sub>2</sub>=20:1.

#### DESIGN AND APPLICATION FOR FORCED-VIBRATION PENDULUM WITH WIDE FREQUENCY RANGE FOR INTERNAL FRICTION MEASUREMENT

Beijing WULI [PHYSICS] in Chinese Vol 15 No 2, Feb 86 pp 109-110

[Article by Wen Yiting [2429 0076 3060], Wang Litian [3769 0500 3944] and Du Jiaju [2629 1367 7467] of Institute of Solid Physics, Chinese Academy of Sciences]

[Abstract] For a long time, the low-frequency torsional pendulum has been extensively applied in internal friction studies. In this arrangement, the vibration amplitude and frequency of a vibration system (during free attenuation) are measured. This method has certain limitations: there will be a large error when the internal friction is high; and within the operating frequency range of the torsional pendulum, the temperature may rise to a high value in

some relaxation process--thus the configuration of the test specimen will undergo changes. As early as the 1940's, the forced-vibration torsional pendulum was further developed in the mid-1970's. This method directly measures the difference in phase angle in which strain lags behind the stress. The article presents a frequency forced-vibration pendulum capable of measuring the internal friction and the modulus of elasticity at the extremely low frequency of  $10^{-3}$  Hz with a relatively wide frequency range between  $10^{-3}$  and 5 Hz. Four figures show a model of a vibration system and its stress-strain curves, an experimental layout, photo-electric measurement of angular displacement, and temperature spectra of internal friction peaks of crystal boundary. The authors are grateful to the following individuals: professor Ge Tingsui [5514 0080 3606] for his advice; Xie Cunyi [6200 1317 3015] and Chen Hui [7115 2547] for taking part in some of the experiments; and Gu Chunhui [7537 2504 2547] and his colleagues at the internal friction research team for their assistance.

#### OPTICAL SOLITON AND FIBER COMMUNICATION

Beijing WULI [PHYSICS] in Chinese Vol 15 No 2, Feb 86 pp 111-116

[Article by Dong Xiaoyi [5516 1321 5030], Institute of Modern Optics, Nankai University]

[Abstract] Liberally interpreted, a soliton is a kind of wave whose energy is confined to a limited range while propagating at a certain velocity. The optical soliton can be interpreted as follows: when a coherent optical pulse passes through a medium, its front part acts and excites the medium while its rear part is acted upon by the excited medium with a gain. The energy loss in the front part is equal to the energy gain in the rear part. Thus, there is no energy loss for the optical pulse. This is the optical soliton phenomenon. The optical soliton makes possible a fantastic capacity in optical fiber communication, since Mollenauer et al. of the Bell Laboratories developed for the first time, in 1984, an optical soliton laser capable of more than 10 billion bits per second of transmission speed in a 75 km optical-fiber circuit. This transmission speed is higher by several magnitudes over the best, modern optical fiber communication. The article presents the propagation features of coherent optical pulses, nonlinear effect and automatic phase adjustment of optical fiber, operating equations of the optical soliton, and optical soliton laser shown in one of six figures. Five other figures show input and output pulses, widening or narrowing of chirp optical pulses while passing through a dispersive medium, characteristic curves of the best commercially available single-mode optical fiber, narrowing of optical pulses (with positive chirp) while passing through an optical fiber, and propagation of a pulse envelope outline with and without distortion.

10424/12859  
CSO: 4009/77

RENORMALIZED STRONG TURBULENCE THEORY FOR LOW-FREQUENCY MAGNETIC FIELD AND  
ION ACOUSTIC WAVE EXCITED BY HIGH-FREQUENCY WAVE

Beijing WULI XUEBAO [ACTA PHYSICA SINICA] in Chinese Vol 35 No 3, Mar 86  
pp 283-299

[English abstract of article by He Xiantu [6320 6343 0960] of the Institute  
of Applied Physics and Computational Mathematics, Beijing]

[Text] In this paper the renormalized turbulence theory for the low-frequency magnetic field and the ion acoustic wave in high temperature plasma is developed in order to improve the usual weak nonlinear approach. From Vlasov-Maxwell equations, the coupled renormalized equations of the high and low frequency propagator, with the "most divergence" and "secondary divergence" effects included, are derived in the Fourier representation. Thus, we obtain the coupled relation of the renormalized particle distribution function and a field for high and low frequency oscillation.

Under the "most divergence" renormalization approximation, the propagator equations for high and low frequency are solved. Expanding to the order of  $v_e$ , the ratio of the energy density of the high frequency turbulence field to the thermal energy density of the plasma particle, the approximate solutions for the propagator and the expressions for the renormalized dielectric function are obtained. Then, by performing a Fourier inverse transformation, the renormalized strong turbulence equations are derived in the space-time representation.

Finally, as an example showing the renormalized effects under one-dimensional and stationary approximations, the analytical form for the soliton is solved.

DENSITY PROFILE STEEPENING DUE TO LASER RADIATION IN MAGNETIZED INHOMOGENEOUS PLASMA

Beijing WULI XUEBAO [ACTA PHYSICA SINICA] in Chinese Vol 35 No 3, Mar 86  
pp 311-318

[English abstract of article by Xu Zhizhan [1776 5267 1455], et al., of  
Shanghai Institute of Optics and Fine Mechanics, Chinese Academy of Sciences]

[Text] The effects of a self-generated magnetic field on the density profile modification in laser-plasma interactions are studied by calculating the field structure, assuming that plane electromagnetic waves propagate into a one-dimensional inhomogeneous magnetized plasma. The results obtained by computation are in agreement not only with the laser-target experiments using Nd-glass laser, but also with those using a CO<sub>2</sub> laser. In addition, calculations show the density dip which has been observed in experiments.

STUDY OF THIN FILM WITH COMPLEX REFRACTION INDEX BY SPECTROSCOPIC ELLIPSOMETRY--  
OPTICAL CONSTANT DISPERSION AND GROWTH RATE OF ITO

Beijing WULI XUEBAO [ACTA PHYSICA SINICA] in Chinese Vol 35 No 3, Mar 86  
pp 319-328

[English abstract of article by Feng Hongan [7458 3163 1344], et al., of  
Zhongshan University]

[Text] In this paper we propose a method which makes it possible to investigate films with complex refraction index using spectroscopic ellipsometry. By introducing a new aiming function, the search parameter space can be reduced to four-dimensions, enabling us to calculate not only the optical constant and thickness of the films, but also the optical constant of the substrate simultaneously. Using this method we studied the optical constant dispersion and the growth rate of ITO films deposited on Si substrates by sputtering. At the same time we observed that the apparent optical constants of the Si substrates were changed.

STRUCTURAL AND MAGNETIC PROPERTIES OF  $\text{Nd}_2(\text{Fe}, \text{Si})_{17}$  ALLOYS

Beijing WULI XUEBAO [ACTA PHYSICA SINICA] in Chinese Vol 35 No 3, Mar 86  
pp 352-358

[English abstract of article by Hu Boping [5170 0130 1627], et al., of the  
Institute of Physics, Chinese Academy of Sciences]

[Text] In this paper, structural and magnetic studies are carried out on the alloys of the iron-rich Nd-Fe-B ternary system. The results show that for the iron-rich ( $\text{Fe} > 40$  at percent) alloys, a ternary compound  $\text{Nd}_2\text{Fe}_2\text{Si}_2$  is formed ( $\text{Si} > 20$  percent) as well as a pseudobinary compound  $\text{Nd}_2(\text{Fe}, \text{Si})_{17}$ , in which Si atoms are substituted for the iron atoms on 9d-sites instead of forming a new ternary compound such as  $\text{Nd}_2\text{Fe}_{14}\text{B}$ . Upon substitution of Si for Fe, both the cell volume and magnetization of the  $\text{Nd}_2(\text{Fe}, \text{Si})_{17}$  alloys decrease, but the Curie temperature  $T_C$  increases due to an enhancement of the ferromagnetic interaction in the Fe sublattice. The room temperature anisotropy fields decrease with increasing Si content as a result of the reduction of the plane anisotropy in the Fe sublattice.

CRYSTALLIZATION OF AMORPHOUS Ge IN Ge/Au, Ge/Ag BILAYER FILMS AND Ge-Au, Ge-Ag ALLOY FILMS

Beijing WULI XUEBAO [ACTA PHYSICA SINICA] in Chinese Vol 35 No 3, Mar 86  
pp 365-374

[English abstract of article by Zhang Renji [1728 0086 0165] of the Department of Mechanical Engineering, Qinghua University; Chu Shenglin [5969 5110 7792] of the Department of Physics, Beijing University; and Wu Ziqin [0702 5261 0530] of the Fundamental Physics Center, University of Science and Technology of China]

[Text] In this article, as-evaporated and annealed samples of Ge/Au, Ge/Ag bilayer films and Ge-Au, Ge-Ag alloy films were investigated by TEM. In situ observations of Ge/polycrystalline Au (p-Au) and Ge/p-Ag films during heating were also made by TEM. It was found that the crystallization temperature  $T_c$  of amorphous Ge (a-Ge) in a-Ge/p-Au was much lower than  $T_c$  of a-Ge/monocrystalline Au (m-Au). It is shown that the boundary triple points and other interface defects of p-Au films are the favorable nucleating positions for a-Ge crystallization in bilayer films.  $T_c$  of a-Ge in the condensation regions of Ge/p-Au films ( $\approx 100^\circ\text{C}$ ) is lower than  $T_c$  ( $\approx 150^\circ\text{C}$ ) in the noncondensation regions. There are some large Ge grains in the condensation regions because of the effect of favorable crystallization in local regions.  $T_c$  of a-Ge in a-Ge/p-Ag and a-Ge/m-Ag films is about  $280^\circ\text{C}$ .  $T_c$  of alloy films is higher than that of correlative bilayer films when the metallic content in the alloy film is low ( $C_{\text{Au}} < 17$  at percent,  $C_{\text{Ag}} < 18$  at percent).  $T_c$  of alloy films is lower than that of bilayer films when the metallic content is relatively high. This is because the supersaturation of the metallic ions reduces the crystallization potential barrier of a-Ge significantly.

TEMPERATURE EFFECTS OF OPTICAL PHONON FOR  $ZrH_{1.7}$  AND  $PdH_{0.7}$

Beijing WULI XUEBAO [ACTA PHYSICA SINICA] in Chinese Vol 35 No 3, Mar 86  
pp 389-392

[English abstract of article by Ruan Jinghui [7086 2529 6540], et al., of  
the Institute of Atomic Energy, Beijing]

[Text] The optical phonon spectra for  $ZrH_{1.7}$  (containing 0.2 percent C) and  $PdH_{0.7}$  are measured at room temperature and low temperature (97 K) with a beryllium filter detector spectrometer adjacent to the heavy water pile in the Institute of Atomic Energy. The results show that:

(1) the optical phonon energy level for  $ZrH_{1.7}$  is essentially equal spacing, the width of the energy level essentially does not change with T, i.e., the anharmonicity of the optical phonon is weak and it obeys Einstein's harmonic model.

(2) The second optical phonon energy level spacing for  $PdH_{0.7}$  is about 8 meV larger than that of the first spacing level, and the width of its optical phonon energy level changes from 38 meV at room temperature to 20 meV at 97 K. This means that the optical phonons which play important roles in the superconductivity of  $PdH_x$  exhibit significant anharmonicity.

THE  $2\Delta_0/(k_B T_c)$  AND PARAMETERS OF PHONON SPECTRUM FOR AMORPHOUS SUPERCONDUCTORS

Beijing WULI XUEBAO [ACTA PHYSICA SINICA] in Chinese Vol 35 No 3, Mar 86  
pp 397-402

[English abstract of article by Cao Xiaowen [2580 2400 2429] of the Institute of Plasma Physics, Chinese Academy of Sciences, Hefei]

[Text] In this paper we propose a formula

$$\frac{2\Delta_0}{k_B T_c} = 4.95 \left[ 1 - \frac{T_0 \langle \omega \rangle^{\frac{1}{2}}}{A} \left( \frac{1}{\lambda \omega_0} + \frac{1}{20\lambda \langle \omega \rangle} + \frac{1}{20 \langle \omega \rangle} \right) \right],$$

to describe the relationships between  $2\Delta_0/(k_B T_c)$  and the parameters of the phonon spectrum of disordered and amorphous superconductors for the non-transition metals and their alloys. Here  $T_0 = 0.66K$ ,  $A = \frac{1}{5} K^{\frac{1}{2}}$ ,  $\lambda$  is the electron-phonon coupling constant,  $\langle \omega \rangle$  is the average phonon frequency and  $\omega_0$  the high frequency cutoff of the effective phonon spectrum  $\alpha^2 F(\omega)$ . The values of  $2\Delta_0/(k_B T_c)$  of disordered and amorphous superconductors which have the known parameters of the phonon spectrum have been calculated. The agreement with the experimental data is within a few percentage points. We show that the amorphous superconductor of non-transition metals and alloys is either a strong coupling superconductor which has a  $2\Delta_0/(k_B T_c)$  value much larger than the BCS theory value or a weak coupling superconductor which has a considerably smaller value than the BCS theory one.

9717

CSO: 4009/76

Physics

TWO-WINDOW FOURIER TRANSFORM TECHNIQUE AND ITS APPLICATION IN SPECTRUM  
ANALYSIS OF QUANTUM OSCILLATIONS

Beijing WULI XUEBAO [ACTA PHYSICA SINICA] in Chinese Vol 35 No 4, Apr 86  
pp 443-450

[English abstract of article by He Yusheng [0149 6276 3932] of the Department  
of Physics, Qinghua University]

[Text] The conventional Fourier transform methods were found to give an inadequately accurate and complete spectrum of the quantum oscillation frequencies for some materials with complicated Fermi surfaces, such as IV-VI compounds in the distorted phase. Because of this problem, the early de Haas-van Alphen data of SnTe could not be interpreted properly. The "two window Fourier transform" technique was developed, and it solved this problem successfully in the Fermi surface measurements of  $Pb_{1-x}Sn_xTe$  and SnTe. In this technique, spectrum analysis is performed twice for each set of data by using two different windows, referred to as "strong window" and "weak window" respectively, so as to increase the signal to noise ratio and to detect components with weaker strength and resolve neighboring components of similar strength. Therefore, higher detectability and resolvability and better accuracy can be achieved. The results of analysis of the pseudo-SdH simulation signal, consisting of 10 components with different amplitudes, show that the error in frequency of the spectrum is less than 1 percent.

TEMPORAL AND SPECTRAL FEATURES OF  $3(\omega_0)/2$  SPATIALLY FINE STRUCTURES IN LASER IRRADIATED PLANAR TARGETS

Beijing WULI XUEBAO [ACTA PHYSICA SINICA] in Chinese Vol 35 No 4, Apr 86  
pp 459-466

[English abstract of article by Lin Zunqi [2651 1415 3825], et al., of Shanghai Institute of Optics and Fine Mechanics, Chinese Academy of Sciences]

[Text] Both temporally and spectrally resolved fine structures of  $90^\circ$  lateral  $3(\omega_0)/2$  harmonic emissions were experimentally observed. The existence of  $3(\omega_0)/2$  harmonic filaments is attributed to the  $3(\omega_0)/2$  harmonic radiation emitted from the neighborhood of the bottom of the moving filament, about  $n_c/4$  away from it. The double hump structure with an intense red hump of a laterally emitted  $3(\omega_0)/2$  spectrum can also be explained by Doppler correction in addition to the thermal correction due to the fast moving TPD process occurring in the unstable filaments. An estimate of both red and blue shifts using the authors' simple model is quite consistent with experimental results. Experiments showed that the  $3(\omega_0)/2$  emission was obviously suppressed using a broad band laser due to more uniform illumination on the target surface and the broad band effect. These may be promising for superhot electron suppression.

LOW-TEMPERATURE MAGNETIC PROPERTIES OF AMORPHOUS  $Nd_xT_{1-x}$  (T = Fe, Co, Ni)  
THIN FILMS

Beijing WULI XUEBAO [ACTA PHYSICA SINICA] in Chinese Vol 35 No 4, Apr 86  
pp 475-481

[English abstract of article by Dai Daosheng [2071 6670 3932], et al., of  
the Institute of Solid State Physics, Beijing University]

[Text] The magnetic structure and anomalous behavior of the temperature dependence of magnetization at low temperatures for amorphous  $Nd_xT_{1-x}$  (T = Fe, Co, Ni) thin films are discussed. It has been observed that the sudden drop of magnetization is at about 20 K, and the temperature corresponding to the sudden drop on the magnetization curves does not change with composition. We suggest that, as the neodymium component exceeds a certain amount, in the ground state the asperomagnetic and speromagnetic structures may coexist for these amorphous alloys. The sudden drop of magnetization at about 20 K may be explained by the phase transition between the speromagnetism and paramagnetism. The critical composition of the neodymium component for coexistence of these magnetic structures approximately corresponds to  $x \geq 0.45$ , 0.20 and 0.08 for Nd-Fe, Nd-Co and Ni-Ni amorphous thin films, respectively.

THEORY OF FTIR-Q SWITCH RESONATOR

Beijing WULI XUEBAO [ACTA PHYSICA SINICA] in Chinese Vol 35 No 4, Apr 86  
pp 523-528

[English abstract of article by Zhang Zhenxi [1728 6966 6007]; et al., of  
the Department of Physics, Northwest University, Xi'an]

[Text] The fundamental theory of the development of the FTIR-Q switch resonator is described. The resonator is composed of many optical elements and cannot be solved by the conventional method. Combining matrix optics with integral equations of diffractions of the optical resonator, we obtain a theoretical solution which produces many quantities, such as Fresnel number, diffraction losses, resonance frequency and its interval, etc., that can be compared with the results of the parallel plane resonator.

EXPERIMENTAL EVIDENCE OF N-S STATE OF NON-EQUILIBRIUM SUPERCONDUCTOR

Beijing WULI XUEBAO [ACTA PHYSICA SINICA] in Chinese Vol 35 No 4, Apr 86  
pp 540-544

[English abstract of article by Yang Qiansheng [2799 0051 5116], et al., of  
the Institute of Physics, Chinese Academy of Sciences]

[Text] Superconducting lead film is driven into the non-equilibrium state by tunnel injection of quasi-particles. There are two kinds of zero resistance states under the same injection level, depending upon the sample history. With the help of double tunnel injection, we found one of them in the homogeneous non-equilibrium superconducting state and the other in the N-S nonhomogeneous one.

RESISTIVE STATE OF NON-EQUILIBRIUM SUPERCONDUCTOR NEAR  $T_c$

Beijing WULI XUEBAO [ACTA PHYSICA SINICA] in Chinese Vol 35 No 4, Apr 86  
pp 545-548

[English abstract of article by Yang Qiansheng [2799 0051 5116], et al., of  
the Institute of Physics, Chinese Academy of Sciences]

[Text] Superconducting Sn films are driven into the non-equilibrium state by tunnel injection of quasi-particles. The voltage across the films starts to appear when injection current increases to a certain value. Near the transition temperature of the Sn films,  $T_c$ , the corresponding resistance increases rapidly with the increasing temperature. The behavior is similar to the resistance of the normal-superconductor interface. However, the observed effect is orders of magnitude larger than the N-S interface resistance and the value of resistance will decrease suddenly, even vanish, when the injection current increases to a higher threshold value  $I''_t$ .

THEORY OF CRITICAL TEMPERATURE FOR SUPERCONDUCTORS WITH SMALL  $\lambda$  (III)

Beijing WULI XUEBAO [ACTA PHYSICA SINICA] in Chinese Vol 35 No 4, Apr 86  
pp 549-552

[English abstract of article by Weng Zhengyu [5040 1767 1342], et al., of  
the Department of Physics, University of Science and Technology of China,  
Hefei]

[Text] The  $T_c$  formula, derived in previous papers of this series, is  
examined by comparing the  $T_c$  values calculated from it, either with the  
numerical solutions of the Eliashberg equation or with the experimental  
values of various superconductors. The agreement between them is  
satisfactory for superconductors with small  $\lambda$ .

9717

CSO: 4009/72

IN-FIELD CALIBRATION OF ALBEDO NEUTRON DOSIMETER

Beijing GAONENG WULI YU HE WULI [PHYSICA ENERGIAE FORTIS ET PHYSICA NUCLEARIS] in Chinese Vol 10 No 3, May 86 pp 265-270

[English abstract of article by Lei Zhuanheng [7191 0278 5683], et al., of the Institute of High Energy Physics, Chinese Academy of Sciences]

[Text] The Albedo neutron personnel dosimeter has been more and more widely used due to its small volume and ease in measurement. Attention should be paid to the calibration technique which finally determines the error of the measurement. In fact, there usually exists a certain difference between the energy spectrum of the radioactive source for calibration and that of the radiation field to be measured. In order to improve the accuracy of the measurement, the problem of the in-field calibration technique should be solved. In this paper, the in-field calibration method and the use of the so-called Bonner cylinder for the in-field calibration of the accelerator are described.

SU(9) GRAND UNIFICATION MODEL OF SUBQUARKS

Beijing GAONENG WULI YU HE WULI [PHYSICA ENERGIAE FORTIS ET PHYSICA NUCLEARIS] in Chinese Vol 10 No 3, May 86 pp 271-276

[English abstract of article by Zhang Xinmin [1728 2450 3046], et al., of Xinxiang Teacher's College]

[Text] An improved version of the grand unification composite model proposed earlier is suggested. Under the hypothesis of partly broken global chiral symmetry, we present a four-member family of Fermions at low energies to realize unification of the four-member family of Fermions. The neutrino may naturally acquire the Dirac mass. The proton lifetime and weak neutral current at low energy are consistent with experimental results.

A NEW CO-BOUNDARY OPERATOR AND ITS APPLICATIONS

Beijing GAONENG WULI YU HE WULI [PHYSICA ENERGIAE FORTIS ET PHYSICA NUCLEARIS] in Chinese Vol 10 No 3, May 86 pp 283-287

[English abstract of article by Zhou Guangzhao [0719 0342 0664], et al., of the Institute of Theoretical Physics, Chinese Academy of Sciences]

[Text] In this paper new co-boundary operators are defined in the product form. The associative composition law of the spatial translation group field is discussed using these new operators. The quantization condition of monopoles in SU(2) and SU(3) gauge theories follows easily from the new formalism.

STUDY OF DEEP INELASTIC COLLISION OF  $^{12}\text{C} + ^{27}\text{Al}$  AT ENERGY 61.8 MeV

Beijing GAONENG WULI YU HE WULI [PHYSICA ENERGIAE FORTIS ET PHYSICA NUCLEARIS] in Chinese Vol 10 No 3, May 86 pp 323-329

[English abstract of article by Feng Enpu [7458 1869 2528], et al., of the Institute of Modern Physics, Chinese Academy of Sciences]

[Text] By using a  $\Delta E$ -E telescope and the time of flight detector, the energy spectra of products between  $^6\text{Li}$  and  $^{16}\text{O}$  were measured for the reaction  $^{12}\text{C} + ^{27}\text{Al}$ , at 61.8 MeV. The contour plots of the differential cross section in the c.m. system and the angular distributions of emitted fragments were obtained. The calculated values of fully relaxed energies in deep inelastic collisions agree with the experimental values. The mean interaction time of the di-nuclear system was estimated to be from  $1 \times 10^{-21}$  s to  $1.4 \times 10^{-22}$  s.

MICROSCOPIC OPTICAL POTENTIAL CALCULATIONS OF FINITE NUCLEI WITH EXTENDED SKYRME FORCES

Beijing GAONENG WULI YU HE WULI [PHYSICA ENERGIAE FORTIS ET PHYSICA NUCLEARIS] in Chinese Vol 10 No 3, May 86 pp 335-342

[English abstract of article by Yuan Haiji [5913 3189 7535], et al., of Hangzhou University; and Shen Qingbiao [3947 1987 1753] of the Institute of Atomic Energy, Chinese Academy of Sciences]

[Text] Microscopic optical potential calculations in the Hartree-Fock (HF) approximation with extended Skyrme forces are investigated. The HF equation is derived from the variation principle and the potential formula of spherical nuclei is obtained by two different methods. Then the calculations for symmetric nuclei  $^{16}\text{O}$ ,  $^{40}\text{Ca}$  and asymmetric nucleus  $^{90}\text{Zr}$  with eight sets of Skyrme force parameters are presented. Our results show that the potential form and varying tendency with incident energy are reasonable and there apparently appears a "wine-bottle-bottom" shape in the intermediate energy region. In addition, our calculations clearly reflect shell effects.

A NEW TRANSITION BRANCH OF THE 5.2 SEC ISOMER IN  $^{183}\text{W}$

Beijing GAONENG WULI YU HE WULI [PHYSICA ENERGIAE FORTIS ET PHYSICA NUCLEARIS] in Chinese Vol 10 No 3, May 86 pp 354-357

[English abstract of article by Gui Shouzao [2981 1108 6644], et al., of the Institute of Nuclear Research, Chinese Academy of Sciences]

[Text] During the bombardment of a 14.8 MeV neutron on natural wolfram samples, a  $\gamma$ -ray with energy of 291.7 keV and halflife of  $5.17 \pm 0.03$  sec is observed. From the experimental facts it is assumed that, in addition to the two well-known transition branches from the decay of the 5.2 sec isomer in  $^{183}\text{W}$ , there exists another  $11/2^+ 11/2[615] \rightarrow 5/2^- 3/2[512]$  isomeric (E3) transition. The hindrance factor of this new transition is calculated. It is quite consistent with the general empirical rule of the  $k^-$  forbidden isomeric transition.

OBSERVATION OF EXCITED STATES IN  $^{128}\text{Ba}$

Beijing GAONENG WULI YU HE WULI [PHYSICA ENERGIAE FORTIS ET PHYSICA NUCLEARIS] in Chinese Vol 10 No 3, May 86 pp 363-366

[English abstract of article by Zhao Zhizheng [6392 0037 2973], et al., of the Institute of Modern Physics, Chinese Academy of Sciences]

[Text] Excited states of  $^{128}\text{Ba}$  are investigated via the  $^{120}\text{Sn}(^{12}\text{C}, 4n\gamma)^{128}\text{Ba}$  reaction by means of in-beam gamma spectroscopy. A  $12^+$  state other than the previously reported one is observed according to the properties of the 935.0 keV  $\gamma$ -ray. It does not belong to the ground state band. Two new interband transitions, 224.8 keV and 632.7 keV, are observed and assigned to sidefeeding between the negative-parity band and ground state band.

9717

CSO: 4009/80

END