

UNIVERSITY OF TORONTO

**THE DURABILITY OF REINFORCED  
POLYMERS UNDER ADVERSE  
ENVIRONMENTS:  
INTERFACE EFFECTS**



DEPARTMENT OF CHEMICAL ENGINEERING  
AND APPLIED CHEMISTRY

19981020 093

**USAF0SR CONTRACT NO: F49620-95-1-0148**

**THE DURABILITY OF REINFORCED  
POLYMERS UNDER ADVERSE  
ENVIRONMENTS:  
INTERFACE EFFECTS**

**By:**

**M.R. PIGGOTT**

**Department of Chemical Engineering and Applied Chemistry  
University of Toronto,  
Toronto, Ontario M5S 3E5 Canada**

**FINAL REPORT**

**AUGUST 1998**

**DISTRIBUTION STATEMENT A**

**Approved for public release;  
Distribution Unlimited**

**DTIC QUALITY INSPECTED 4**

# REPORT DOCUMENTATION PAGE

AFRL-SR-BL-TR-98-

18

Public reporting burden for this collection of information is estimated to average 1 hour per response, including gathering and maintaining the data needed, and completing and reviewing the collection of information, including suggestions for reducing this burden, to Washington Headquarters, Suite 1204, Arlington, VA 22202-4302, and to the Office of Management and Budget, Paperwork Project, Washington, DC 20503.

data sources, aspect of this 1215 Jefferson

0669

1. AGENCY USE ONLY (Leave blank)		2. REPORT DATE August 1998		3. REPORT TYPE AND DATES COVERED FINAL REPORT Feb. 15, 1995 - Feb. 15, 1998	
4. TITLE AND SUBTITLE THE DURABILITY OF REINFORCED POLYMERS UNDER ADVERSE ENVIRONMENTS: Interface Effects				5. FUNDING NUMBERS F49620-95-1-01-84	
6. AUTHOR(S) M.R. PIGGOTT					
7. PERFORMING ORGANIZATION NAME(S) AND ADDRESS(ES) University of Toronto Toronto, Ontario M5S 3E5 Canada				8. PERFORMING ORGANIZATION REPORT NUMBER	
9. SPONSORING/MONITORING AGENCY NAME(S) AND ADDRESS(ES) AFOSR/NA 110 Duncan Avenue Suite B115 Bolling AFB, Washington, DC 20332-8050				10. SPONSORING/MONITORING AGENCY REPORT NUMBER	
11. SUPPLEMENTARY NOTES					
12a. DISTRIBUTION/AVAILABILITY STATEMENT Approved for public release; distribution unlimited.				12b. DISTRIBUTION CODE	
13. ABSTRACT (Maximum 200 words)  Three types of experiments have been carried out to determine interface properties: single fibre pull out, transverse tests on unidirectional composites and peel tests on single fibres. The pull out tests were shown to give misleading results: interfaces which pull out suggested were as strong or stronger than the matrix, yielded transverse strengths which were low, and transverse fracture surfaces which had abundant bare fibres on them. Transverse tests showed that composites are weakened by water, but did not clearly reveal whether a weakened interface was a contributory factor. Peel tests did show that some interfaces are weakened by water. Interfaces studied included glass, carbon and Kevlar with epoxy and carbon-PEEK. This last was very resistant to water, being virtually unaffected after 8000 h at 90°C.					
14. SUBJECT TERMS Reinforced Plastics, Fibre Composites, Environment Resistance Fibre-Polymer Interface				15. NUMBER OF PAGES 19	
				16. PRICE CODE	
17. SECURITY CLASSIFICATION OF REPORT		18. SECURITY CLASSIFICATION OF THIS PAGE		19. SECURITY CLASSIFICATION OF ABSTRACT	
				20. LIMITATION OF ABSTRACT	

## FINAL REPORT

# THE DURABILITY OF REINFORCED POLYMERS UNDER ADVERSE ENVIRONMENTS: Interface Effects

### EXECUTIVE SUMMARY

The interface between the fibres and the polymer is a major factor governing the integrity of a reinforced plastic. When glass fibres are used they have to be specially coated to prevent environmental agents such as water from weakening the interface and hence the composites. Carbon fibre surfaces are less susceptible, but carbon reinforced plastics are known to be weakened by heat and water. This research program was carried out to determine to what extent the interface was responsible for any weakening effect.

The first approach to the problem was to use one of the standard tests; i.e. single fibre pull out. It quickly became clear that the test was giving misleading results, so instead two different approaches were used.

One of these was the transverse test on a unidirectional composite. With carbon-epoxies it was shown that the test was sensitive to the interface strength but so far only qualitative data have been obtained. The weakening effect of water at high temperature on the composite was clearly shown, but this was mainly due to the weakening of the polymer itself. With carbon fibre reinforced PEEK the interface was very strong; actually stronger than the polymer itself. This composite was barely affected by water, even at 90°C. Both the interface and the matrix seemed to be highly resistant.

The other test used was the peel test on single fibres. This was difficult to carry out and gave somewhat scattered results. However, the effect of water at the carbon-epoxy interface was easily detected: a reduction of 80% was observed after only 100 h at 90°C. With glass the reduction was 95% after only 20 h at 90°C.

In view of the promising nature of the transverse strength results, an extension of the program has been agreed to. This will concentrate initially on quantifying the method, and the study will then be extended to include laminate structures with multidirectional fibres. In addition, the peel test will be used to examine other environments.

## 1. INTRODUCTION

The interface between the fibres and the polymer is a key element of a reinforced plastic. It transfers the stress between the components, and governs the integrity of the material. Properties dependent on a good bond include the compressive strength, the apparent shear strength, the transverse tensile strength, and the fatigue and environment resistance.

The strength of the bond is usually investigated using tests on single fibres, and the property which the standard tests (fragmentation, pull out, microtension and microcompression) attempt to measure is the shear strength of the bond.

The loss of adhesion between glass fibres and polymers due to environmental effects is well known [1] and although mitigated by the use of silane and other coupling agents, can be easily demonstrated by pull out experiments. Thus, for example, 13 kh immersion in 23°C water caused a loss of 20% in the apparent bond strength between silane coated glass and polyester, while 400 h immersion at 75°C caused an almost total loss. The 23°C effect was reversible: the strength recovered after 72h at 80°C in air. However, after the 75°C immersion, the strength did not recover [2].

Tests on the composites themselves have been more widely used to investigate environment effects. Thus the transverse strength of a 1975 vintage carbon-epoxy suffered some loss due to moisture [3]. This was not shown to be an interface effect. However, it is well known that Tg is reduced by moisture absorption [4], and the resin swells [5]. With PEEK however, moisture effects are very slight: for example, flexure tests on carbon-PEEK laminates indicated only an 8% loss in apparent shear strength after 24h in 95°C water [6].

There is some evidence, however that the carbon fibre interface can be weakened by water. Thus D<sub>2</sub>O has been shown to travel preferentially along the fibre tows in a carbon-epoxy, and the accompanying water ingress can cause early failure of joints [7].

Kevlar fibres absorb very significant amounts of water [8] and the apparent shear strength of a Kevlar-epoxy is reduced by 50% after 7 days in 100°C water [8]. Pull out tests indicate no loss in adhesion after 2.3 kh immersion in 23°C water when the fibres were untreated before being embedded. However, when treated with acetone or xylene before embedment there was a 50% loss after immersion [9].

When this research was proposed, it was considered that the standard tests were suitable for measuring interface strengths. Thus two of them (i.e. fibre fragmentation and pull out) formed a major part of the experimental program envisaged. However, it became

clear that anomalously high apparent interface shear strengths observed experimentally with these techniques [10, 11] indicated a major problem. So the debonding process of a glass fibre from a clear epoxy was observed under the microscope. This revealed that the process involved slow crack propagation until only about 3 fibre diameters along the interface were supporting the total load of about 1.5 N. At this stage, the mean shear stress in the polymer adjacent to the interface was 550 MPa, i.e. nearly ten times greater than the polymer tensile strength [12]. Final failure was too rapid to be observed.

Subsequent to this, the concept of shear failure in polymer matrices was critically investigated. This study showed that shear failure did not occur. Instead, the shears induced tensile failure, even in cases such as the punch test, which can exert shear strains as great as 80,000% before failure [13].

This has led to significant changes in this research program, in particular the gradual phasing out of single fibre tests and their replacement by transverse tests on unidirectional composites.

## **2. EXPERIMENTAL METHODS**

### **2.1 PULL OUT EXPERIMENTS**

PEEK, epoxies with various curing agents, and a polyimide were used for the pull out experiments. For the thermosets the fibres were embedded in polymer contained in capsules. These were made of steel for high temperature resin curing, and polyethylene microvials were used for lower temperature cures.

The stainless steel capsule is shown in fig. 1. It had a grub screw in the bottom. The polymer shrinks on cooling down after cure, and so clamps itself onto the screw, fig. 1a. The capsule was therefore coated with release agent to ensure that the resin did not adhere to it and create tensile stresses at the fibre-matrix interface. The release agent was baked on.

Thirty nine capsules were held in a carousel, and the fibres were held in glass capillaries above the liquid polymer; see fig. 2. One by one they were lowered into the polymer using a micrometer screw, while being observed through a binocular microscope. Once all 39 fibres were immersed to the appropriate depths, the carousel was removed from its base and put into an oven to cure the resin.

In the case of polyimide (LARC PETI5) very little resin was used because of the volatiles produced during cure: see fig. 1b.. A two stage curing process was used: 290°C for 2 hr to remove the solvent and 370°C for 1/2 hr to effect final cure.

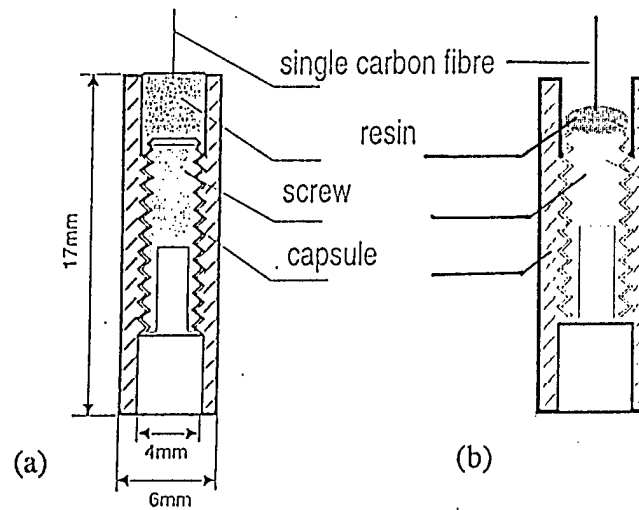

Fig. 1 Stainless steel capsule used for high temperature thermoplastics and thermosets (a) normal use (b) special arrangement for polyimide.

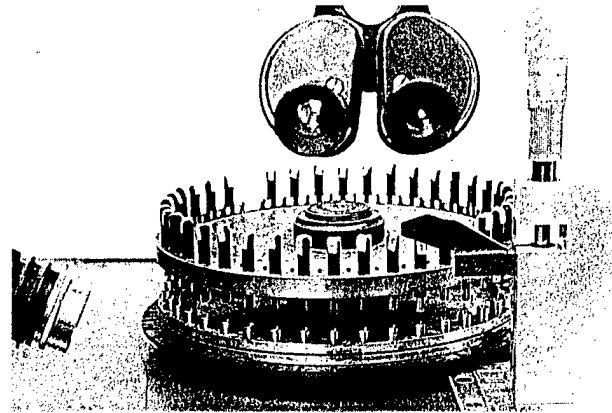

Fig. 2. Carousel arrangement used for fibre embedment into thermosets.

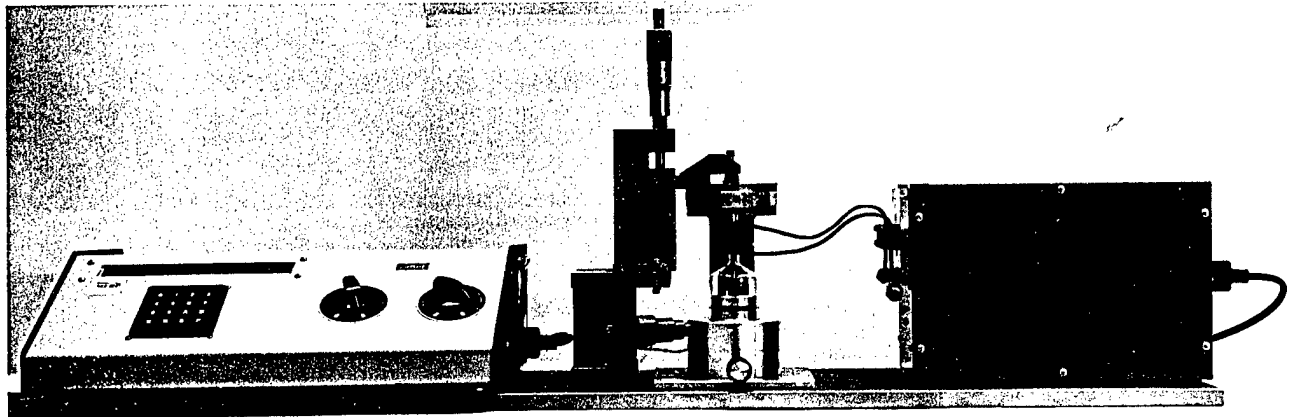

Fig. 3. Induction heater set-up for fibre embedment into PEEK.

A different process was used for the PEEK. The stainless steel capsules, containing powdered PEEK, were heated in a specially constructed microprocessor controlled by low power (200W) induction heater. After melting at 420°C, the PEEK was consolidated and the fibre advanced into it, as for the uncured epoxy. The capsule was surrounded by nitrogen to ensure that oxidation of the PEEK was minimized: see fig. 3. Cooling was carried out under microprocessor control at 3°Cs<sup>-1</sup>. Meanwhile, the fibre was advanced into the polymer to ensure it was not left high and dry as the polymer shrank.

The fibre pull out was carried out using a Table Model Instron. The capsule hung from the load cell with the fibre pointing down. A copper sheet was adjusted so that the fibre was just in contact with it over most of its non-embedded length. Krazy glue was then used to attach the fibre to the sheet. The free length of fibre,  $\lambda$ , was kept below 0.5 mm; see fig. 4. Pull out was carried out at 0.5 mm min<sup>-1</sup>.

## **2.2 TRANSVERSE TESTS**

Unidirectional composites were made by pultrusion and compression molding. They were about 3 mm thick. They were cut to a width of 18 mm for the epoxy and 25 mm for the carbon reinforced PEEK with a length of 150 mm. With the more brittle resins, the edges were carefully polished down to 0.5  $\mu$ m alumina to ensure that any cracks introduced by the cutting process were removed. The reinforced PEEK samples hereinafter referred to as APC2 were smoothed with abrasive down to 800 mesh rather than polished. The samples were then end tabbed.

Testing was carried out in a servohydraulic machine at a rate of 2 mm min<sup>-1</sup>. An extensometer was used in some tests to determine the transverse modulus.

## **2.3 PEEL EXPERIMENTS**

Fibres were carefully laid on partially cured epoxy resin held in a capsule; see fig. 5. They were allowed to sink to about half their diameter and the resin was then cured.

In early experiments the Table Model Instron was used to pull the fibres off obliquely. Since the forces were very small, especially at higher angles of peel, the testing was transferred to a Chan 1000 Automatic Balance.

## **2.4 ENVIRONMENTAL EXPOSURE**

Pull out and transverse test samples were immersed in distilled water at controlled temperatures for various lengths of time, using a water bath. Some samples were dried out after various durations of immersion and then tested.

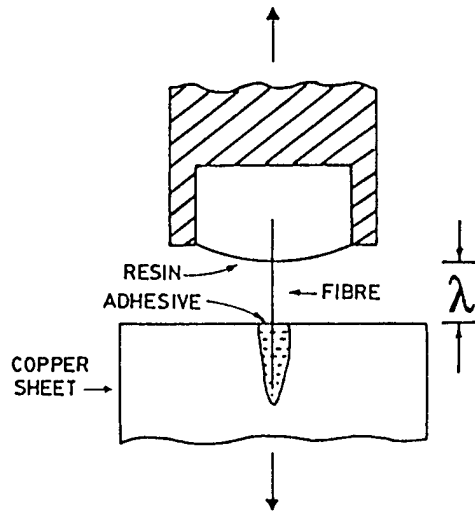

Fig. 4. Set-up used for single fibre pull out tests.

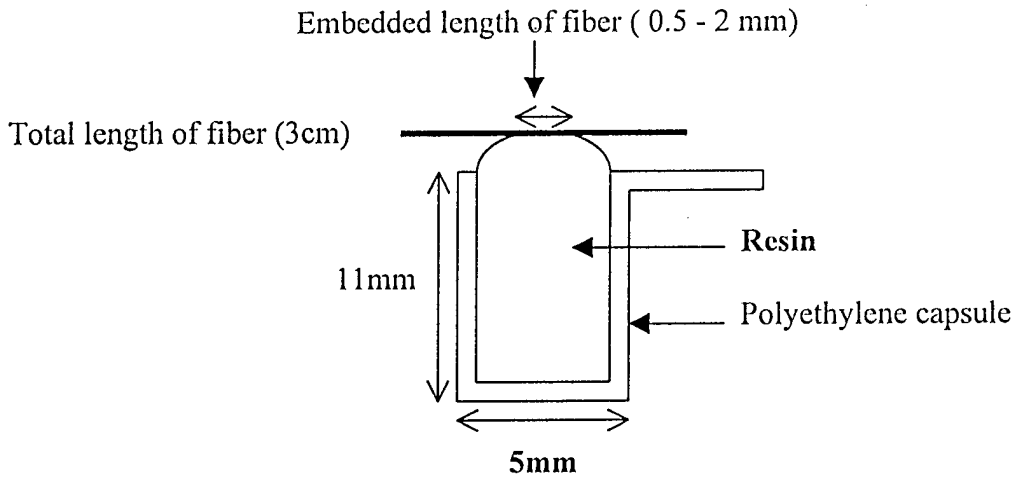

Fig. 5. Schematic drawing of peel specimen preparation process.

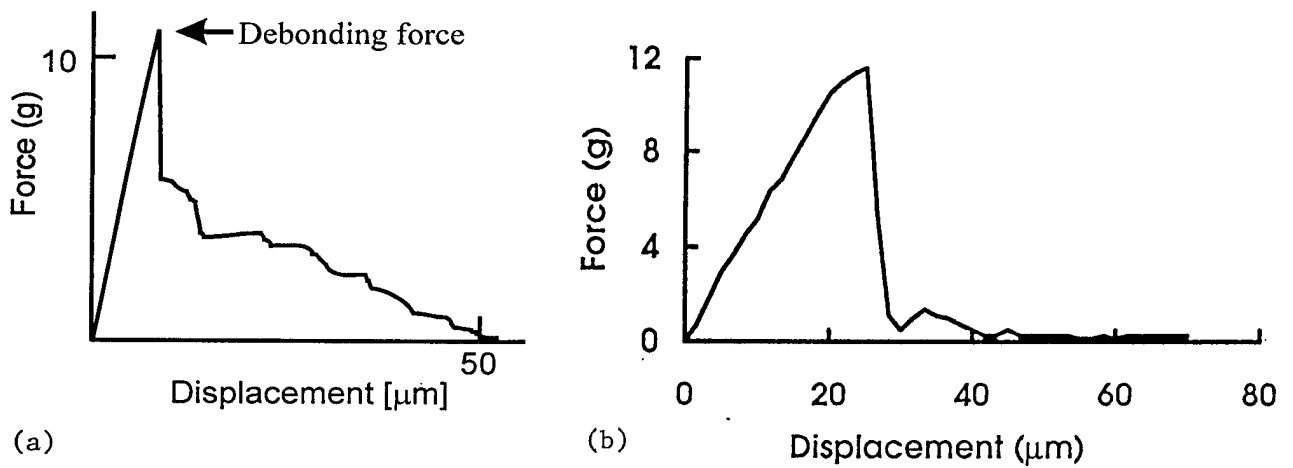

Fig. 6. Typical force-distance curves for carbon being pulled out of a) epoxy and b) PEEK.

The peel samples were also immersed in water at various temperatures for various lengths of time before being tested.

### 3. EXPERIMENTAL RESULTS

#### 3.1 PULL OUT

Typical force-distance curves for carbon fibres pulled out of epoxy and PEEK are shown in fig. 6. The initial monotonically increasing region was never quite straight and usually had one or two slope changes. Because the embedded lengths were smaller, the forces were smaller for the PEEK. This accounts for the rougher appearance of the pull out curve in this case. Although every effort was made to ensure that the fibre did not pierce a bubble in the PEEK, this was not always successful. These cases give anomalous pull out curves and these results were discarded.

The embedded length was less well controlled in the case of PEEK, so was checked both on the pull out curve (i.e. the distance pulled when the force fell to zero) and under the microscope. (The polymer remains adhering in the region of the fibre entry, so this point is readily identified.) As can be seen from fig.7, the agreement between the two measures is good.

Maximum force vs embedded length plots were different for different systems. Glass in epoxy had a linear region, then a plateau, fig. 8a, while when DC 20 coated it was more of a scatter diagram, with the maximum apparent mean shear strength ( $\tau_{max}$ ) an order of magnitude greater than the minimum, fig. 8b. AS4 carbon-epoxy gave higher apparent shear strengths than HMU carbon; see fig. 9. Table 1 lists values of the apparent mean shear strengths estimated from the maximum forces.

The pull out properties of carbon-PEEK were examined in more detail. Two slope changes were usually observed, designated as  $F_y$  and  $F_{ds}$ , in addition to the maximum force  $F_{dc}$ . These are plotted vs embedded length,  $L$ , in fig. 10., together with the frictional shear  $F_f$ , estimated from the mean slope after the force recovered from its fall from  $F_{dc}$ .

The pull out curves and plots of  $F_y$ ,  $F_{ds}$ ,  $F_{dc}$ ,  $F_f$  vs  $L$  showed most of the same features after water treatment, and after subsequent drying out. Table 2 shows the data obtained from the plots. The approximate equivalent mean shear stresses  $\tau_y$ ,  $\tau_{ds}$ ,  $\tau_{dc}$  and  $\tau_f$  were estimated for each individual result. For example

$$\tau_y = my/\pi d \quad (1)$$

where

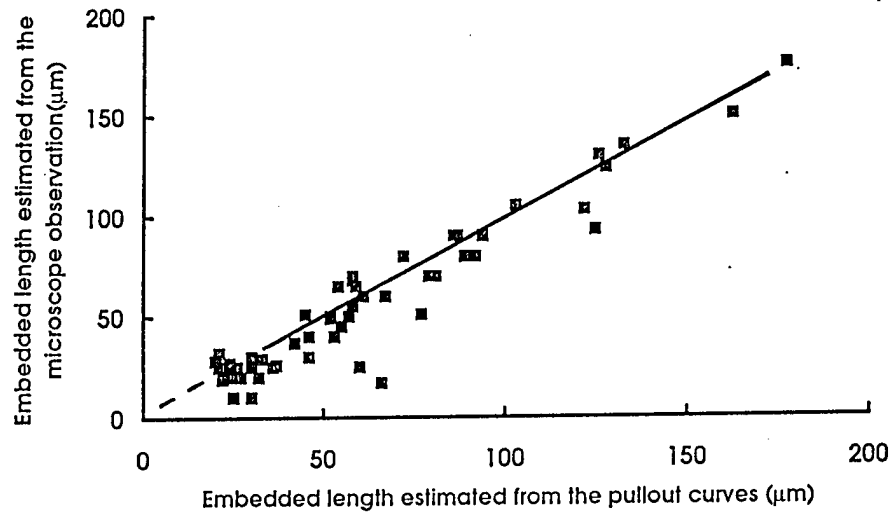

Fig. 7. Fibre embedded length estimated using the microscope vs that estimated from the force-distance curve.

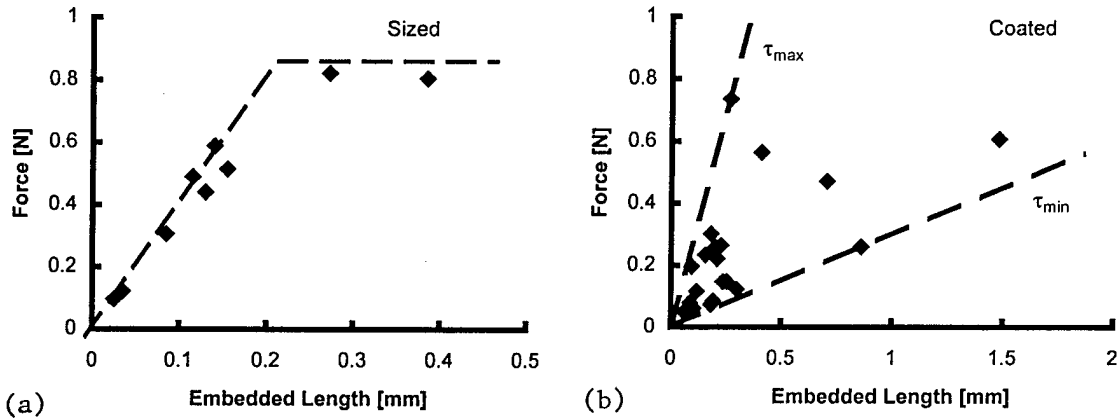

Fig. 8 Debonding force vs embedded length for pull out experiments with a) sized E-glass and b) DC. 20 release agent coated E-glass in epoxy.

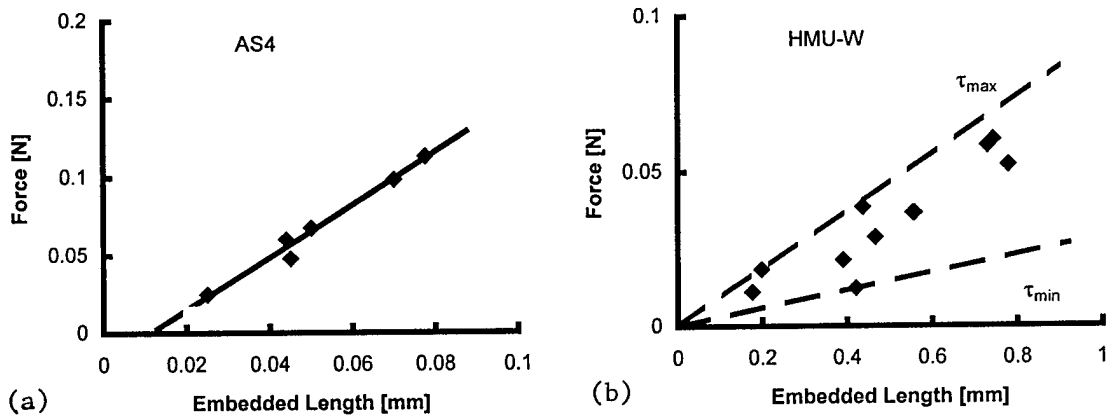

Fig. 9 Debonding force vs embedded length for pull out experiments with a) AS4 carbon and b) HMU carbon in epoxy.

TABLE 1.  
RESULTS FROM SINGLE FIBRE PULL OUT EXPERIMENTS ON  
THERMOSETS

Fibre	Matrix	AISS* (MPa)
E-glass	Epoxy <sup>1</sup>	55 ± 11
E-glass DC 20	Epoxy <sup>1</sup>	14 ± 8
AS1 carbon	Epoxy <sup>1</sup>	71 ± 9
AS1 <sup>a</sup> carbon	Epoxy <sup>1</sup>	44 ± 8
AS1 carbon	Epoxy <sup>4</sup>	52 ± 8
AS1 <sup>b</sup> carbon	Epoxy <sup>4</sup>	39 ± 6
AS4 carbon	Epoxy <sup>1</sup>	51 ± 8
AU4 carbon	Epoxy <sup>2</sup>	64 ± 21
HMU carbon	Epoxy <sup>3</sup>	3 ± 1
AS4 carbon	Polyimide	16 ± 3

## Notes:

Fibre coatings: a) Frekote 44-NC, b) DC 20

Curing Agents: 1) Anchor 1171, 2) Amicure 101, 3) Anchor 1040, 4) TETA

\* AISS = mean apparent interfacial shear strength

TABLE 2.  
RESULTS FROM SINGLE FIBRE PULL OUT EXPERIMENTS WITH  
CARBON PEEK

treatment			shear stresses				plateau value on each graph		
water temperature (°C)	immersion time (hours)	desiccation time (hours)	$\tau_y$ (Mpa)	$\tau_{ds}$ (Mpa)	$\tau_{dc}$ (Mpa)	$\tau_i$ (Mpa)	Fy (mN)	Fds (mN)	Fdc (mN)
	no treatment	history	65±25	82±27	85±29	11±8	118±39	162±31	176±46
60	1		67±27	68±27	76±31	13±7	127±22	145±28	148±32
	10		72±22	68±22	74±25	11±6	98±33	130±28	156±46
	100		63±29	74±26	75±31	11±7	134±35	148±48	152±34
	1000		44±22	56±16	61±19	6±5	120±26	149±40	162±47
90	1		52±23	62±22	69±26	7±4	90±13	129±18	145±41
	10		46±18	63±14	66±21	5±4	111±10	148±13	160±15
	100		58±20	64±27	69±24	7±5	102±16	158±15	166±53
	1000				56±12	13±11	76±31	98±32	115±48
	3000		29±13	52±15	57±19	8±5			
90	1000	360	46±17	57±17	62±19	6±4			

$$m_y = \frac{1}{n} \sum_{i=1}^n F_{y_i} / L_i \quad (2)$$

$n$  is the number of results, and  $F_{y_i}$  is the value of  $F_y$  for an embedded length  $L_i < L_c$ . ( $L_c$  is the intersection of the horizontal dashed line, drawn at the "plateau" value and the solid line through the origin.)

The  $\tau_{ds}$ ,  $\tau_{dc}$  and  $\tau_f$  were estimated in a similar fashion, although for  $F_f$  no plateau was observed, so all the results could be used. It should be emphasized that these were all pull out results. If the fibre broke instead of pulling out, the result was not used.

The lump of polymer still stuck to the pulled out fibre was in the form of a  $\sim 45^\circ$  cone in the case of carbon-epoxy; see fig. 11. In the case of PEEK, however, the long meniscus region gave the fibre entry point a completely different appearance, also shown in fig. 15. The fibres normally came out without any significant amount of polymer visible on the failed interface.

### **3.2 TRANSVERSE TESTS**

Typical force-distance plots for AS4 carbon-epoxy and APC2 are shown in fig. 12. The epoxy extended less than the PEEK at failure and the plots curved downwards continuously. The water immersion had no consistent effect on the extension to failure.

Transverse strengths were reduced as fibre volume fraction was increased, both for AS4 carbon-epoxy and HMU carbon-epoxy; see fig. 13. Water also reduced the strength of AS4 carbon-epoxy at  $60^\circ\text{C}$ ; see fig. 14, the effect being very serious at  $90^\circ\text{C}$ ; after about 100 h the specimens disintegrated. However, the effect of water on APC2 at  $90^\circ\text{C}$ ; was very small, as shown in fig. 14.

The transverse strength of the HMU laminate was very low, i.e.  $17 \pm 2$  MPa at  $V_f = 0.2$  and  $12 \pm 2$  MPa at  $V_f = 0.4$ .

The transverse moduli of the APC2 composites were hardly affected at all by water. Data on moduli for some of the systems tested are given in table 3.

### **3.3 PEEL TESTS**

Typical force-distance plots from peel tests are shown in fig. 15. Unsuccessful tests, involving fibre failure before peeling had started, gave the type of plot shown in fig. 15a. Successful tests gave plots shown in fig. 15b. Partly successful tests, with fibre failure occurring after a few peels and arrests, are illustrated in fig. 15c.

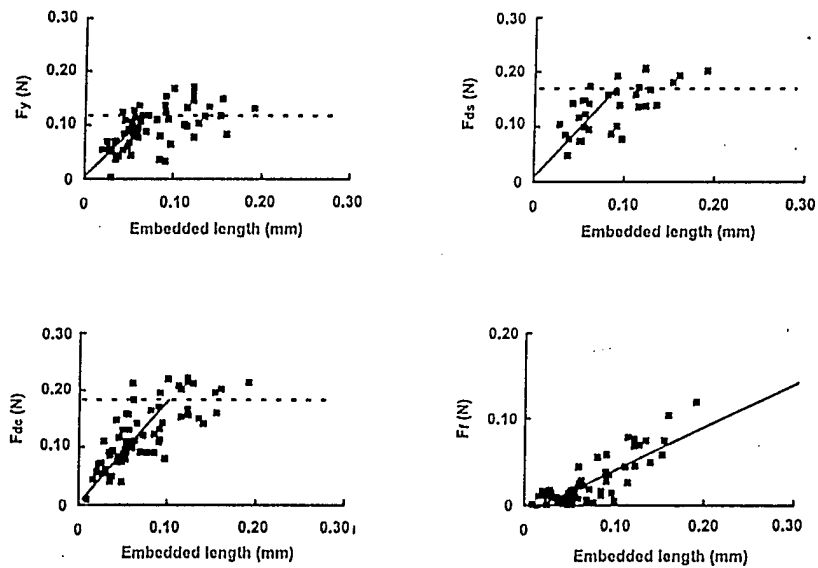

Fig. 10 Forces for first slope change,  $F_y$ , second slope change,  $F_{ds}$ , maximum force,  $F_{dc}$ , together with maximum post-debonding frictional force  $F_f$ , all vs fibre embedded length,  $L$ . Specimens not water treated.

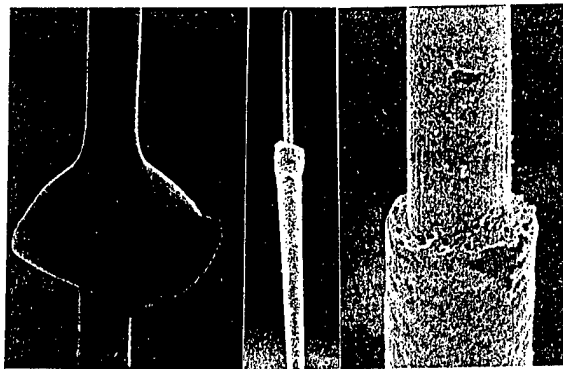

Fig. 11. AS4 carbon pulled out fibres: at left from epoxy; centre from PEEK, showing long meniscus region; at right, detail of pull out. All fibres  $8.0 \mu\text{m}$  diameter.

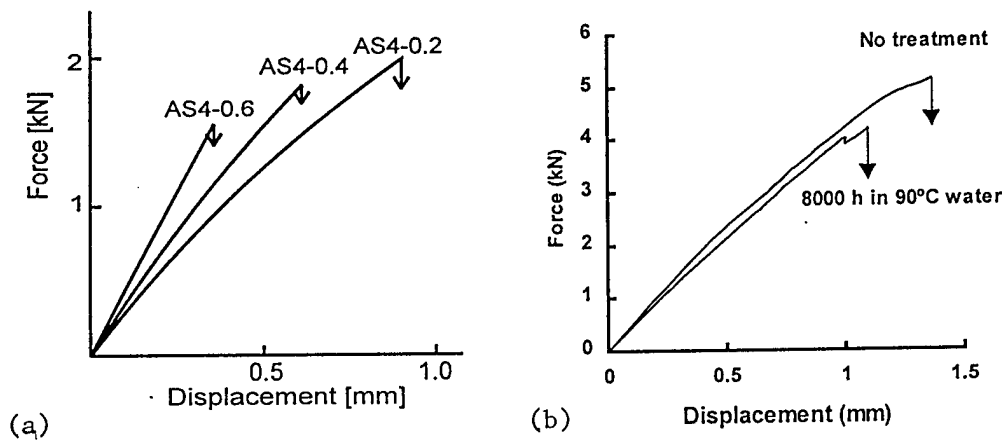

Fig. 12. Typical force-distance plots for transverse tests (a) AS4 carbon-epoxy with volume fractions of 0.2, 0.4, and 0.6 and (b) APC2 untreated and after 8000h immersion in  $90^\circ\text{C}$  water.

TABLE 3.

## RESULTS FROM TEST ON POLYMERS AND TRANSVERSE TESTS ON COMPOSITES

Matrix modulus ( $E_m$ ) and Strength ( $\sigma_{mu}$ ), Volume Fraction of Composites ( $V_f$ ) together with Composite Modulus ( $E_c$ ), Strength ( $\sigma_{2u}$ ) and Breaking Strain ( $\epsilon_{2u}$ )

Fibre-Matrix	$E_m$	$\sigma_{mu}$	$V_f$	$E_c$ (GPa)	$\sigma_{2u}$ (MPa)	$\epsilon_{2u}$ (%)
E-glass-epoxy <sup>1</sup>	2.8 ± 0.1	49 ± 3	0.40	7.0 ± 0.4	34 ± 4	0.7 ± 0.1
E-glass <sup>a</sup> -epoxy <sup>1</sup>	2.8 ± 0.1	49 ± 3	0.40	-	10 ± 1	-
Carbon <sup>b</sup> -epoxy <sup>1</sup>	2.8 ± 0.1	49 ± 3	0.40	6.4 ± 0.6	27 ± 5	0.6 ± 0.1
Carbon <sup>c</sup> -epoxy <sup>1</sup>	2.8 ± 0.1	49 ± 3	0.40	-	7 ± 1	-
Carbon <sup>b</sup> -epoxy <sup>2</sup>	3.0 ± 0.1	61 ± 5	0.40	-	30 ± 7	-
Carbon <sup>d</sup> -epoxy <sup>2</sup>	3.0 ± 0.1	61 ± 5	0.41	-	6.3 ± 0.7	-
Carbon <sup>e</sup> -epoxy <sup>1</sup>	2.8 ± 0.1	49 ± 3	0.20	4.4 ± 0.2	32 ± 6	1.1 ± 0.2
Carbon <sup>e</sup> -epoxy <sup>1</sup>	2.8 ± 0.1	49 ± 3	0.30	5.1 ± 0.2	29 ± 7	1.0 ± 0.2
Carbon <sup>e</sup> -epoxy <sup>1</sup>	2.8 ± 0.1	49 ± 3	0.40	5.6 ± 0.3	29 ± 7	0.7 ± 0.2
Carbon <sup>e</sup> -epoxy <sup>1</sup>	2.8 ± 0.1	49 ± 3	0.60	7.8 ± 0.2	26 ± 3	0.4 ± 0.1
Carbon <sup>f</sup> -epoxy <sup>1</sup>	2.8 ± 0.1	49 ± 3	0.20	3.9 ± 0.3	13 ± 2	0.4 ± 0.1
Carbon <sup>f</sup> -epoxy <sup>1</sup>	2.8 ± 0.1	49 ± 3	0.40	5.4 ± 0.2	12 ± 2	0.26 ± 0.03
Carbon <sup>e</sup> -PEEK	3.9 ± 0.1	90 ± 1	0.67	9.4 ± 0.5	89 ± 3	1.13 ± 0.07
Carbon <sup>e</sup> -PEEK	3.9 ± 0.3 <sup>3</sup>	90 ± 2 <sup>3</sup>	0.67	9.9 ± 0.7 <sup>4</sup>	91 ± 2 <sup>4</sup>	0.92 ± 0.06

## Notes

Fibres: a) glass coated with DC 20, b) AS1, c) AS1 coated with DC 20, d) AS1 coated with Frekote 44-NC, e) AS4 and f) HMU  
 Curing Agent: 1) Anchor 1171, 2) TETA  
 Immersion in 90°C water: 3) 3000 h, 4) 8000 h

TABLE 4.

## 90° PEEL STRENGTHS FOR SINGLE FIBRES ON EPOXY

Fibre	Diameter	Peel Strength (mN)
Glass	22	6 ± 2
Kevlar	12	6 ± 1
Carbon	8	1.0 ± 0.3

TABLE 5.

## INTERFACE RESULTS COMPARED WITH OFF-AXIS TEST RESULTS FOR AS1 CARBON-EPOXY

Curing Agent	Uncoated Fibres				Release Agent Coated Fibres		
	$\sigma_{mu}^1$ (MPa)	$\sigma_{2u}^2$ (MPa)	$V_m^3$	$\tau_{iu}^5$ (MPa)	$\sigma_{2u}^2$ (MPa)	$V_m^3$	$\tau_{iu}^5$ (MPa)
TETA <sup>6</sup>	61 ± 5	30 ± 7	0.60	52 ± 8	6.3 ± 0.7	0.59	39 ± 6
Anchor 1171 <sup>7</sup>	49 ± 3	23 ± 3	0.60	71 ± 9	7 ± 1	0.60	44 ± 8

## Notes:

1. Polymer matrix tensile strength (EPON 815; see 6 & 7 below for curing details)
2. Strength of pulltrusion normal to the fibres.
3. Volume fraction of polymer.
4. Area fraction of polymer in fracture surface produced by off-axis tensile.
5. Debonding force/embedded area of fibre in pull out test.
6. Cured at 120°C for 4 h; 22 phr of curing agent used. Release agent coating was undiluted Frekote 44-NC.
7. Cured at 50°C for 2 h, then 150°C for 2 h with 5 phr curing agent; release agent was Dow Corning DC 20 from a 10% solution in toluene 10 parts and alcohol 80 parts.

The peaks in fig. 15 were assumed to give the force to initiate peeling; thus 15 values could be obtained from fig. 15b, but only four from fig. 15c.

For both carbon and glass the peel force fell steeply with peel angle. For glass the force was about three times that for carbon; see fig. 16. Each value plotted is the result of tests on at least ten fibres.  $90^\circ$  peel strengths are given in table 4.

Immersion of the glass samples in water caused a very rapid decline in peel strength. The effect on carbon was less marked; see fig. 17.

## 4. DISCUSSION

### 4.1 REASONS FOR PHASING OUT THE PULL OUT TEST

The single fibre pull out test can give misleading results. Table 5 compares the matrix strength, the transverse strength of a unidirectional composite, and the apparent mean shear failure stress in a pull out test for the same fibre-matrix combination as in the composite. The pull out test can give an apparent mean shear failure stress which is greater than the polymer strength when the transverse strength is less than the polymer strength (table 5). Furthermore, the transverse failures were accompanied by much bare fibre at the fracture surfaces (fig. 18a) What is seen in the photomicrograph, therefore, strongly suggests that the interface must be weaker than the polymer, while the pull out test indicated that it is stronger. This should be contrasted with the case of PEEK, fig. 18b, where  $\sigma_{2u} \cong \sigma_{mu}$  and there is no bare fibre, indicating that the interface really is stronger than the polymer.

This suggests that the pull out test can produce misleading values for the interface strength and should therefore be phased out.

These results were foreshadowed by work already mentioned in the Introduction. Details were given of apparent interface strengths which were too high. Furthermore, a study of shear induced failure showed that the actual failure process for most polymers is tensile. These considerations stimulated a review of all centrosymmetric tests used for interface evaluation. It was recommended[14] that these tests should all be phased out because they were all designed to induce a non-existent failure process. (Reference 14 is a paper which was written, and appeared in print, during the course of this investigation.)

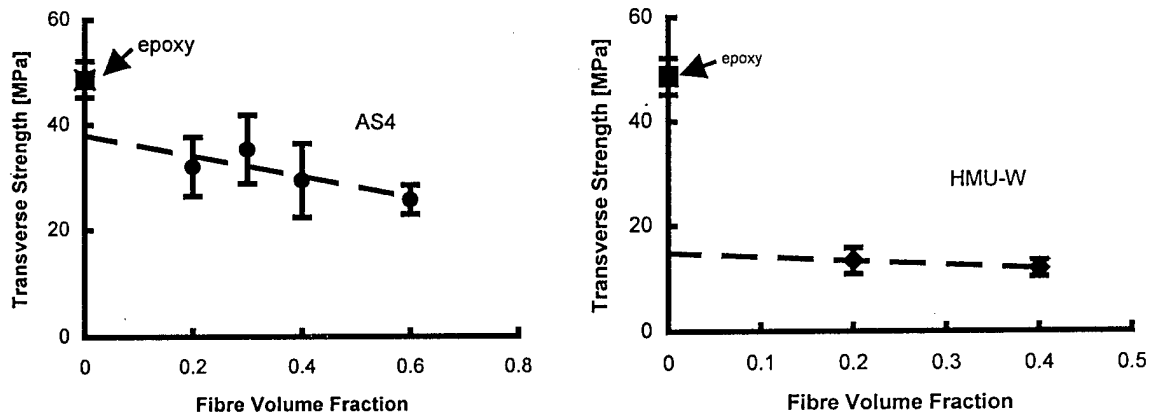

Fig. 13. Transverse strength vs fibre volume fraction for AS4 carbon-epoxy and HMU carbon-epoxy.

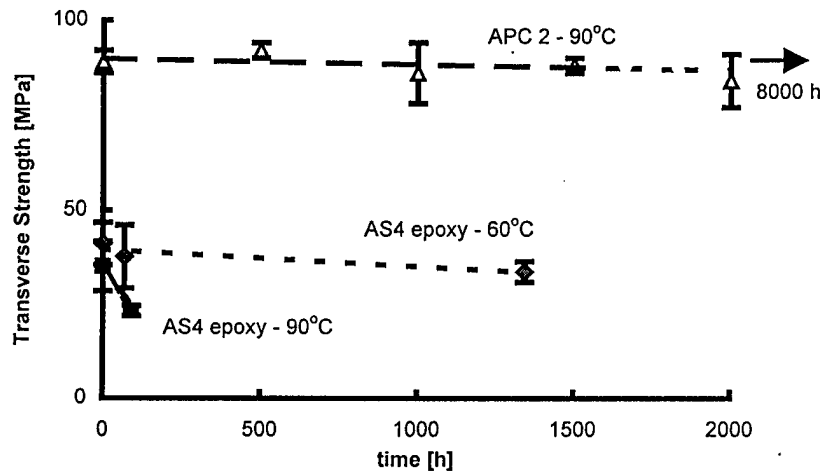

Fig. 14 Effect on transverse strength of immersion in hot water: AS4 carbon-epoxy and APC2.

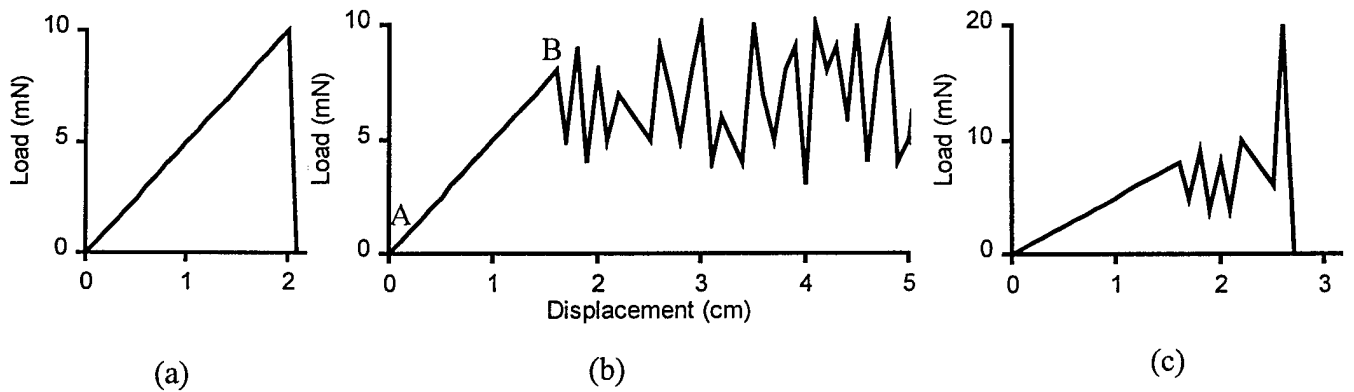

Fig. 15. Typical force-distance plots for peel tests (a) fibre broke without peeling (b) no fibre break (c) fibre broke after some peeling.

Transverse strength tests avoid these problems, but introduce a new one, i.e. to obtain an interface strength we need to allow for the contribution of the matrix. This is further complicated by the stress concentrations in the matrix arising from the presence of the fibres.

The results presented here clearly show that transverse tests can distinguish good fibre-matrix adhesion (APC2) from moderate adhesion (AS4 carbon-epoxy) and poor adhesion. (Release agent coated fibres and HMU carbon-epoxy). Numerical values, however, cannot yet be deduced.

This still represents a significant step forward. Pull out tests give highly scattered results (table 3) as well as being misleading. Furthermore, the centrosymmetric test results are rendered doubtful because of stress concentrations [15], friction during debonding [16], brittle fracture [17] and mixed modality of failure (Modes I & II).

The peel tests appear to give straightforward results. However, the method is difficult to put into effect, and again the results are rather scattered; see fig. 16. Nevertheless it clearly and rapidly reveals the environment effect; see fig. 17.

#### **4.2 ENVIRONMENT EFFECTS**

The glass-epoxy interface is very susceptible to weakening by water; fig. 17a and the AS4 carbon-epoxy interface less so; fig. 17b. For APC2 the transverse tests strongly suggest that this interface is not significantly affected by water. The evidence from transverse tests is less clear in the case of carbon-epoxy because it was difficult to distinguish matrix and interface effects.

The peel test confirms that the interface strength can be reduced in the case of carbon adhering to an epoxy in the presence of water at 90°C.

### **CONCLUSIONS**

Centrosymmetric tests for the evaluation of interface or interphase properties should be phased out. These include fibre pull out, fibre fragmentation, microtension and microcompression.

Transverse tests give a useful guide to the strength of the fibre-matrix bond, especially if coupled with fractography. However, care is needed in the preparation of specimens with the more brittle matrices to ensure that notch effects are minimized.

Peel tests are difficult to carry out but are very sensitive, especially to environment effects.

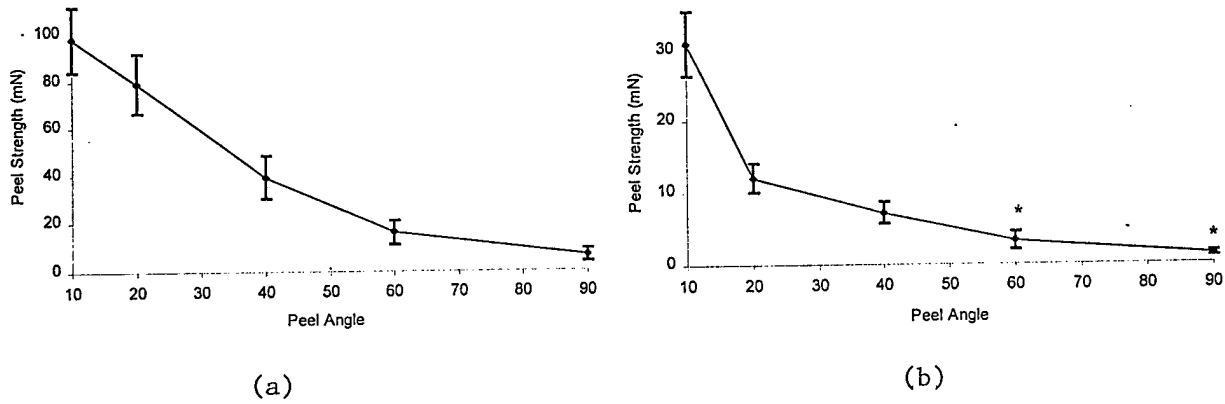

Fig. 16 Peel force vs peel angle (a) glass and (b) carbon

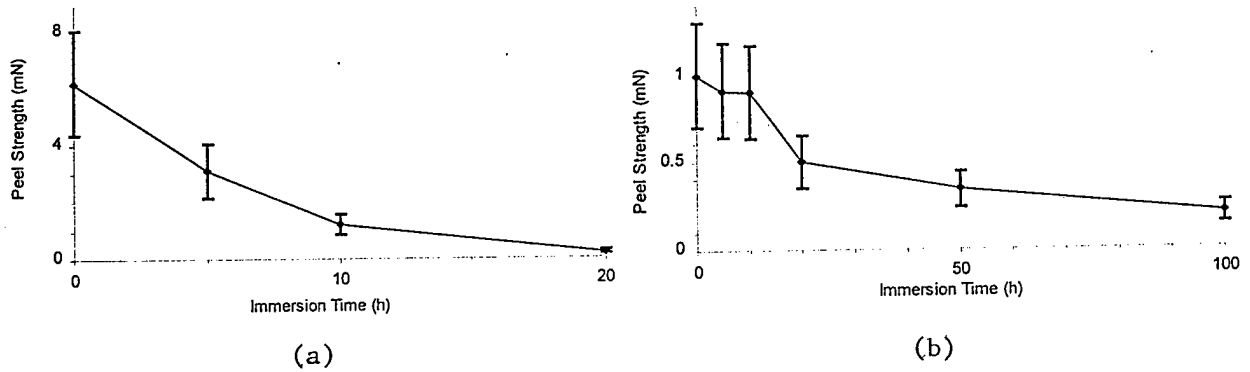

Fig. 17 90° peel strength vs immersion time in water at 90°C (a) glass and (b) carbon

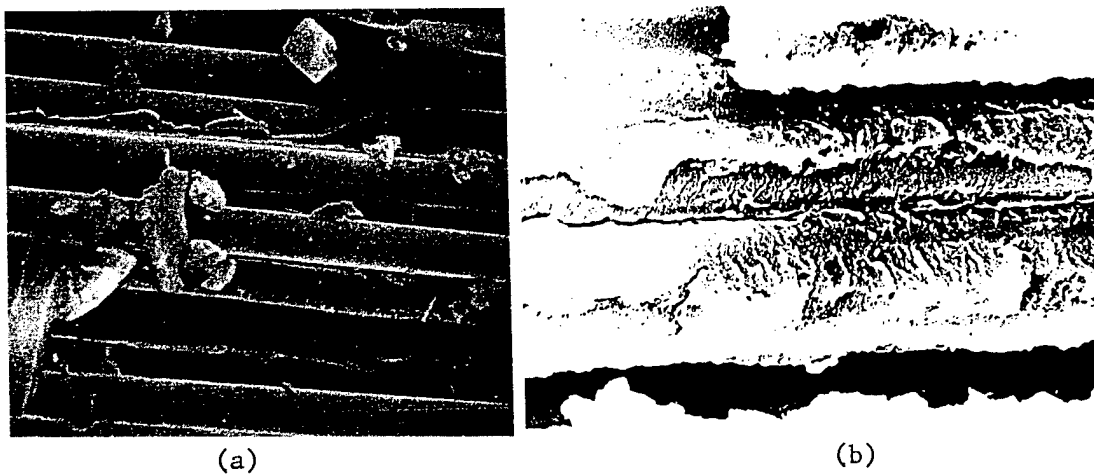

Fig. 18 Fracture surfaces of (a) carbon-epoxy and (b) APC2. The fibres are 8  $\mu$ m diameter.

Water reduces the bond strength of glass-epoxy and AS4 carbon-epoxy, but has very little effect on APC2.

### ACKNOWLEDGMENTS

The writer is greatly indebted to Col. George Haritos for introducing him to the AFOSR Program, and retaining a lively interest since. Also to Dr. Walter Jones who initiated this program and has for many years taken a great deal of interest in the writer's researches in this and other areas. Finally, to Dr. Ozden Ochoa who has guided these researches during the last year, has successfully promoted interactions with other researchers, and has made sure the writer got it mostly right.

### REFERENCES

1. E.P. Plueddemann, Silane Coupling Agents, (Plenman Press, N.Y., 1982), p. 8.
2. P.S. Chua and M.R. Piggott, J. Mat. Sci. 27, (1992), 919-24.
3. C.H. Shen and G. S. Springer, J. Comp. Mater. 11, (1971), 2-16.
4. R. De Iasi and J.B. Whiteside, ASTM STP 658, (1978), 2-20.
5. H.T. Hahn and R.Y. Kim, ASTM STP 658, (1978), 98-120.
6. F.N. Cogswell and M. Hopprich, Composites 14, (1983), 251-3.
7. J.B. Whiteside, R.J. De Iasi and R.L. Schutte, Comp. Sci. Tech 24, (1985), 123-45.
8. D.C. Phillips, J.M. Scott and N. Buckley, Proc. ICCM2, (1978), 1544.
9. M. M. Reboredo, and M.R. Piggott, Comp. Interfaces 2, (1995), 457-72.
10. A.N. Netravali, P. Schwartz, and S.L. Phoenix, Polymer composites, 10, (1989), 226-41.
11. M.R. Piggott and Z.N. Wang, Proc. Am. Soc. Comp., (1991), 725-31.
12. M.R. Piggott and Y. Xiong, Comp. Sci. Tech 52, (1994), 535-40.
13. K. Liu and M.R. Piggott, Polym. Eng. Sci. 38, (1998), 60-68 and 69-78.
14. M.R. Piggott, Comp. Sci. Tech, 57, (1997), 965-74.
15. C. Marotzke, Composite Interfaces, 1, (1993), 153-66.
16. M.R. Piggott, Comp. Sci. Tech. 42, (1991), 57-76.
17. L.S. Penn and S.M. Lee, Comp. Tech. Res., 11, (1989), 23-30.

**APPENDIX**  
**PUBLICATIONS BASED ON THIS WORK**

**1. Theses Completed**

Ms Ping Chen, (M.A.Sc) *"Interfacial Degradation of Carbon Fibre Reinforced PEEK"*, Department of Chemical Engineering and Applied Chemistry, University of Toronto, 1997.

**2. Theses Currently Being Written Up**

Ms. Mimi Chan, (M.A.Sc.), *"Transverse Tests vs Pull Out Tests For Interface Evaluation"*, Department of Chemical Engineering & Applied Chemistry, University of Toronto, 1998

Mr. Li (Alex) Zhang, (M.A.Sc.), *"The Environmental Degradation of the Interface in APC2 as revealed by Transverse Tests"*, Department of Chemical Engineering & Applied Chemistry, University of Toronto, 1998.

Mr. Muhammad Alimuddin, (M.A.Sc.), *"PEEL Tests for the Evaluation of Environment Effects on Fibre-Polymer Interfaces"*, Department of Chemical Engineering & Applied Chemistry, University of Toronto, 1998.

**3. Papers Appearing in Journals**

M.R. Piggott, *"Why Interface Testing Using Single Fibre Method Can Be Misleading"*, Comp. Sci. Tech. 57, (1997), 965-74.

P. Chen and M.R. Piggott, *"Reduction of Fibre Pull Out Stress due to Hot Water Immersion: Carbon PEEK"*, J. Thermoplastic Comp. Mater., accepted 1997.

**4. Journal Papers in Preparation**

M. Chan and M.R. Piggott, *"Transverse Tests For Fibre-Polymer Adhesion Evaluation"*

L. (Alex) Zhang, and M.R. Piggott, *"The Resistance of the Carbon Fibre PEEK Interface to Impairment by Water"*.

M. Alimuddin and M.R. Piggott, *"The Environmental Resistance of Fibre Polymer Interfaces as Revealed by Single Fibre Peel Tests"*.

**5. Papers in Conference Proceedings**

M.R. Piggott, *"The Need for Good Experiments to Establish Basic Mechanics of Fibre Composites"*, Midwestern Mechanics Conference, South Dakota, Sept. 21-24, 1997.

M. Alimuddin, M. Chan, A. Zhang and M.R. Piggott, *"Normal to the Fibre Tests in Unidirectional Composites: Usefulness for Fibre Matrix Interface Strength"*, Amer. Soc. For Comp., Dearborn, MI, Oct. 8, 1997, 1160-66

M.R. Piggott, *"Mechanics of Long-Term Behaviour of High Temperature PMCs-Interface Effects"*, AFOSR Mechanics & Materials Program Review, Dallas Texas, Oct. 27, 1997, 7-11.