

338147

JPRS-CST-86-038

18 SEPTEMBER 1986

# China Report

SCIENCE AND TECHNOLOGY

19981021 108

DTIC QUALITY INSPECTED 4

DISTRIBUTION STATEMENT A

Approved for public release;  
Distribution Unlimited

**FBIS**

FOREIGN BROADCAST INFORMATION SERVICE

REPRODUCED BY  
U.S. DEPARTMENT OF COMMERCE  
NATIONAL TECHNICAL  
INFORMATION SERVICE  
SPRINGFIELD, VA. 22161

2  
109  
AΦ6

## NOTE

JPRS publications contain information primarily from foreign newspapers, periodicals and books, but also from news agency transmissions and broadcasts. Materials from foreign-language sources are translated; those from English-language sources are transcribed or reprinted, with the original phrasing and other characteristics retained.

Headlines, editorial reports, and material enclosed in brackets [ ] are supplied by JPRS. Processing indicators such as [Text] or [Excerpt] in the first line of each item, or following the last line of a brief, indicate how the original information was processed. Where no processing indicator is given, the information was summarized or extracted.

Unfamiliar names rendered phonetically or transliterated are enclosed in parentheses. Words or names preceded by a question mark and enclosed in parentheses were not clear in the original but have been supplied as appropriate in context. Other unattributed parenthetical notes within the body of an item originate with the source. Times within items are as given by source.

The contents of this publication in no way represent the policies, views or attitudes of the U.S. Government.

## PROCUREMENT OF PUBLICATIONS

JPRS publications may be ordered from the National Technical Information Service, Springfield, Virginia 22161. In ordering, it is recommended that the JPRS number, title, date and author, if applicable, of publication be cited.

Current JPRS publications are announced in Government Reports Announcements issued semi-monthly by the National Technical Information Service, and are listed in the Monthly Catalog of U.S. Government Publications issued by the Superintendent of Documents, U.S. Government Printing Office, Washington, D.C. 20402.

Correspondence pertaining to matters other than procurement may be addressed to Joint Publications Research Service, 1000 North Glebe Road, Arlington, Virginia 22201.

18 SEPTEMBER 1986

CHINA REPORT  
SCIENCE AND TECHNOLOGY

CONTENTS

PEOPLE'S REPUBLIC OF CHINA

NATIONAL DEVELOPMENTS

Present Status, Future Outlook for Technology Imports (Cao Jiarui; LIAOWANG OVERSEAS EDITION, No 19, 12 May 86)	1
Nation's Major Chemical Bases Described (Zhou Shikuan; DILI ZHISHI, No 5, 7 May 86) .....	5
Petrochemical Complex East of Daqing Established (Kang Weizhong, Wei Guozhi; LIAOWANG, No 24, 16 Jun 86) ...	13
30 Years of National Space Endeavors Reviewed (HANGTIAN, Nos 2, 3, 27 Mar, 27 May 86) .....	19

PHYSICAL SCIENCES

A Comparison of Sea Surface Temperature Patterns by Remote Sensing Satellite With That by Ship Measurements in the Huanghai Sea and the Bohai Sea (Peng Chengji, R. L. Bernstein; HAIYANG YU HUZAO, No 5, Sep 85) .....	28
Improvements and Tests on HT-1 Sea-Surface Temperature-Humidity- Wind Gradient Buoy (Zhang Qingrong, et al.; NANHAI HAIYANG KEXUE JIKAN, No 4, May 83) .....	37
Deep-Water Moored Buoy System Tested (Chen Fupei; NANHAI HAIYANG KEXUE JIKAN, No 4, May 83) ....	52

APPLIED SCIENCES

Heavy Ion Accelerator Being Built in Lanzhou (Dai Yaping; ZHONGGUO XINWEN SHE, 15 Aug 86) .....	58
--	----

Use of Holographic Technology Developed (Yang Xiaopiong; CHINA DAILY, 2 Jul 86) .....	59
Deep-Water Rescue Vessel Completes Major Mission Tests (RENMIN RIBAO OVERSEAS EDITION, 28 Jun 86) .....	61
Progress in Seismological Studies Reported (XINHUA, 17 Jul 86) .....	62
Seismographer Analyzes Nation's Earthquake Vulnerability (XINHUA, 26 Jul 86) .....	64
Briefs World-Class Gyroscopes .....	65

ENVIRONMENTAL QUALITY

TIBL and SO <sub>2</sub> Concentration on Coast of Dalian (Liu <sup>2</sup> WanJun, Gong Fujiu; HUANJING KEXUE, No 3, 30 Jun 86)	66
---	----

ABSTRACTS

ANALYTICAL CHEMISTRY

YAOXUE XUEBAO [ACTA PHARMACEUTICA SINICA], No 11, 29 Nov 85 .....	73
YAOXUE XUEBAO [ACTA PHARMACEUTICA SINICA], No 12, 29 Dec 85 .....	74

APPLIED MATHEMATICS

YINGYONG SHUXUE HE LIXUE [APPLIED MATHEMATICS AND MECHANICS], No 8, Aug 85 .....	76
YINGYONG SHUXUE HE LIXUE [APPLIED MATHEMATICS AND MECHANICS], No 9, Sep 85 .....	78
YINGYONG SHUXUE HE LIXUE [APPLIED MATHEMATICS AND MECHANICS], No 11, Nov 85 .....	79

COMPUTER SCIENCE

JISUANJI YANJIU YU FAZHAN [COMPUTER RESEARCH AND DEVELOPMENT], No 5, 1986 .....	80
--	----

LASERS

ZHONGGUO JIGUANG [CHINESE JOURNAL OF LASERS], No 7, 20 Jul 86 ....	81
--	----

PHARMACOLOGY AND TOXICOLOGY

YAOXUE XUEBAO [ACTA PHARMACEUTICA SINICA], No 2, 28 Feb 86 .....	89
--	----

YAOXUE XUEBAO [ACTA PHARMACEUTICA SINICA], No 3, 29 Mar 86 ..... 91

PHYSIOLOGY

SHENGLI XUEBAO [ACTA PHYSIOLOGICA SINICA], No 1, Feb 86 ..... 95

SURGERY

ZHONGHUA WAIKE ZAZHI [CHINESE JOURNAL OF SURGERY], No 5, 22 May 86 100

/9986

## NATIONAL DEVELOPMENTS

### PRESENT STATUS, FUTURE OUTLOOK FOR TECHNOLOGY IMPORTS

Hong Kong LIAOWANG OVERSEAS EDITION in Chinese No 19, 12 May 86 pp 18-19

[Article by Cao Jiarui [2580 1367 3843]: "The Present Situation and Problems in China's Technology Imports (Part Two)"]

[Text] Achievement of China's long-term goals for development of the national economy depends on establishing the necessary "extensive" construction as well as on universal "inherent" transformation. Technical transformation now being carried out in some enterprises is of major significance and has a large role in development of China's national economy, something that is becoming more widely acknowledged each day. If an enterprise is unable to sustain technical progress through innovation of regular technologies so that it consistently can use small inputs to obtain possibly greater output and so that its products satisfy social demand to the greatest possible extent not only in terms of quantity but in quality as well, then the value of its existence is brought into question and it can be faced with a crisis of existence. Technical innovation, therefore, is the lifeline of enterprises.

Importing foreign technologies is not the only means of technical innovation, but it is one of the most important ones. When done well, it can even bring an enterprise back to life. A collectively-owned factory in a certain city that had been producing aluminum dielectric capacitors for a long period had products that could not be sold because of poor quality and high costs arising from backward techniques and outdated equipment. They operated at a loss for years and were faced with closing down. In a situation of no grants from administrative departments in higher levels of government, the leaders of the factory decided to take out a bank loan and use a reverse product sales pattern to import new technologies from foreign countries. The new imported equipment was used to transform the factory. Loans are not the same as grants. They must be paid and the interest must be paid, too. Overall, importing via reverse sales involves low-value imports and high-value exports. The leaders at the factory turned pressure into motive force and mobilized all employees in the plant for rapid and high quality completion of technical digestion and absorption and equipment installation and testing work. In less than a year, new life returned to their production and products. Not only did they stop operating at a deficit and begin making a profit but there also was a linear increase in profits and they paid off the loan and interest in a short period of time. If this measure had not been used well, however, it would have led to waste or even a burden on the state society.

During the mid-1970's, state plans made arrangements for importing a type of engine technology that concerned a large number of projects. The technology and the equipment were imported and several tens of "prototypes" also were brought in. Several hundred million dollars were spent but the engines actually could not be used and a solution to the problem did not arise a long time. Of course, imported technologies and equipment do not become completely useless junk, since they can be put to other uses, but the original goal that was envisioned was never attained and the time passed. The large amount of capital invested did not serve its purpose, so it can only be said that this project was unsuccessful.

There are many similar examples. The strangest thing is that technology import projects arranged by state plans often progress in fits and starts, with chaotic management and serious waste. A chemical fiber project during the middle 1970's spent several thousand dollars outside of the contract merely to invite a foreign specialist. An investigative report states that an analysis of more than 30 primary equipment projects during the 1970's indicated that only one-third of the projects had attained the three basic standards of completion and start-up on schedule, operation at full capacity and good operational results. Another investigative report regarding large and medium sized import projects between 1980 and 1982 indicates that six of the nine foreign import projects had rather poor economic results.

## II. What Is the Impetus Behind Technology Imports?

Discovering the causes for these problems may be quite complex. The problems, however, are not unique or accidental, so they force one to ask: what is the motive force behind China's technology imports?

Technology imports are only one means of achieving technical innovation, so we first of all should study the impetus for technical innovation.

Information from the World Bank states that a survey of the sources of technical innovation in the United States between 1953 and 1973 indicates that 80 percent of the new ideas in technical innovations came from within enterprises, and that three-fourths of these came from production departments within these enterprises. Less than 5 percent came from universities or governmental research organs. The same information states that a survey in Europe showed that more than 70 percent of technical innovations came from within enterprises and that the success rate for new ideas that came from commercial personnel was much higher than that for ideas from technical personnel, the figures being 55 percent for the former and 26 percent for the latter. As a result, the conclusion of this information from the World Bank was that market feedback was the most important source of new ideas for technical innovation.

The conclusions in the World Bank information came from the market economy experiences of the developed capitalist nations. China, on the other hand, is a socialist developing nation with a planned economy. Why are we unable to use planned arrangements to replace market feedback so as to promote and encourage technical innovation?

It must be acknowledged that given certain conditions and ranges, focusing on key technical topics and relying on planned arrangements to centralize forces and make key breakthroughs is extremely effective. The nuclear power industry, satellites and other things China has developed without foreign assistance are excellent proof of this. It must be noted, however, that the real situation in China is one in which rapid progress in certain prominent technical breakthroughs has been accompanied by large numbers of examples like Jiefang [Liberation] brand trucks, which have not changed in 20 years. A survey report states that only 20 percent of current industrial technology in China (most from the early 1980's) approximates 1960's and 1970's standards, that 20 to 25 percent is backward but still usable, and that 55 to 60 percent should be discarded and replaced. Many of the research achievements of China's many research academies and institutes are extremely good ones, but only 10 to 30 percent actually can be applied in industrial production. Technical innovation of China's industries occurs extremely slowly. It is obvious that reliance only upon planned arrangements cannot effectively motivate and promote the popularization of technical innovations. The reasons arise from the following aspects:

### III. Planned Arrangements Cannot Promote Universal Technical Innovation

1. The vast majority of production enterprises in China actually are not oriented directly toward the market. The reason may be unified distribution and allocation of their products by materials departments or unified purchasing by commercial departments.
2. The fact that supplies of many products cannot meet demand has led to poor quality and high cost, but they still can be "sold."
3. Certain departments and areas have adopted administrative measures to protect backward enterprises and products in their departments or areas.
4. Production enterprises do not dare risk failing to fulfill plans to carry out technical innovation.
5. The rights of enterprises to control and spend their funds are extremely limited, so it is hard for them to make their own decisions concerning capital for technical innovation.

Although reforms in economic systems have begun, many problems like those outlined above persist.

For this reason, strictly speaking, it would be very difficult given China's current economic system to require that enterprises truly have the impetus for innovation and it also would be quite hard to require enterprises to have the motive force for technical imports. Lacking an impetus for technical imports is different from having no interest or desire for technical imports. In reality, if higher-level administrative and government departments can make the arrangements, assign the tasks, provide the capital and supply the foreign exchange, enterprises usually are happy to or may even compete to accept and take on technical importing tasks with the exception of causes

4 and 5 listed above. The scale of technical imports has grown continually over the past few years and this has occurred in exactly this situation. The problem, however, is the persistence of causes 1 and 2 above. Generally speaking, therefore, if we say that China's enormous technical imports at present reflect real and latent market demand, this is not the same as saying that they reflect the wishes of higher-level governmental and administrative departments or senior officials. The reason is that higher-level governmental departments and senior officials hold the right to examine and approve projects and capital and they control the amount of foreign exchange. The enterprises lack market feedback, while higher-level governmental and administrative departments and senior officials often appear to be even more detached from markets. This is the root of the problem. The systemic separations between departments and regions, the tendency in guiding ideologies toward the establishment of self-sufficient full-function systems, the excessive centralization of authority in governmental departments at all levels, the lack of market feedback mechanisms, and the lack of scientific market research and forecasting methods all are the basic reasons for the lack of strategic deployments and the chaos and mistakes in technical importing in China at the present time. The most obvious and acute expression is so-called redundant importing and decentralized dealing with foreign countries.

Redundant imports of electric refrigerators, washing machines, color televisions and other "hot items" and the dangers involved have been noted by everyone now and the government is adopting measures to control it. This is especially true of several industrial departments at the top level in the central government, which now are playing their real roles and adopting the method of comparing and selecting the best projects to prevent and correct past practices of redundant importing and preliminary results have been seen. I believe that these measures and methods will serve their purpose. The problem, however, is that the departments having jurisdiction can effectively and forcefully focus on evaluation and selection of the best items for certain types of products, but they cannot effectively and energetically focus on evaluation and selection of the best items for every type of technical import product. This may be the only feasible method at present, but it is not a long-term basic solution to the problem.

There are manifest laws in economic development, and there are objective laws to technical innovation and technology imports. The key to planned and focused procedural development with strategic deployments is the need to conform to these objective laws. Taking back authority, more governmental interference and stricter control and guidance is not the correct direction. The correct direction is a need for closer integration with reforms in economic systems and the gradual establishment of macro-level management on the basis of micro-level invigoration. This will be the main topic of the next article. (To be continued)

12539/12947  
CSO: 4008/82

## NATIONAL DEVELOPMENTS

### NATION'S MAJOR CHEMICAL BASES DESCRIBED

Beijing DILI ZHISHI [GEOGRAPHICAL KNOWLEDGE] in Chinese No 5, 7 May 86  
pp 2-4, 6

[Article by Zhou Shikuan [0719 0013 1401]]

[Text] Chemical industry is an important sector of the national economy. It produces tens of thousands products including basic industrial chemicals, new materials, chemical fertilizers, pesticides, synthetic fiber monomers, plastics, and synthetic rubbers, and plays an important role in agricultural and industrial productions, defense constructions, and meeting the needs of people's livelihood. It has a significant impact whether it is stimulating agricultural production, promoting light textile industry, flourishing regional economies or raising the level of production technology. After liberation, China's chemical industry has become strong and big. Numerous well developed, highly specialized, and comprehensive chemical complex that have significant impact at the state or provincial and regional level in terms of production, technology and economy have emerged throughout the country. The outputs of these chemical bases account for over 60 percent of the gross annual national chemical production. They are the integral part of chemical production.

#### Tremendous Development of the Chemical Industry

The degree of maturity of chemical industry is one of the important yardsticks for evaluating the industrial technology level of a country. China has abundant chemical resources, which is especially favorable for developing chemical industry. However, her chemical industry was originally very weak. Before the founding of the Republic, there were only eight larger chemical plants and a few manual workshops in the coastal cities of Shanghai, Tianjin and Dalian as well as Nanjing and Taiyuan. They produced mainly acids and bases together with small volumes of chemical fertilizer and rubber products. They produced only about 100 varieties altogether and the highest yearly production of such major products as sulfuric acid, soda ash, caustic soda and ammonia sulfide (the only fertilizer) were 180,000, 103,000, 15,000, and 230,000 tons, respectively. The organic chemical industry was basically non-existent and a large number of chemical products had to be imported.

After liberation, along with the overall development of the socialist economic construction, the chemical industry has taken the broad road of vigorous growth. In the 1950's, emphasis was placed on the large-scale renovations and expansions of the old complex and old enterprises along the coast. At the same time, 18 large or medium-sized enterprises were established, which included the new complex inland. The large consolidated chemical enterprises at Jilin, Taiyuan, and Lanzhou were among the 158 items of key constructions during the first 5-Year Plan. The production structure of this period was based on chemical fertilizer and acid and base industries. The synthetic organic industry was in its infancy. In the 1960's, the chemical industry turned toward developing depth. Development of coal-based chemical industry was stressed, mainly for using coal tar and calcium carbide as feedstocks to produce fertilizers, organic chemicals and synthetic materials. Throughout the country, over 20 medium-sized fertilizer plants were built near coal production areas, transportation centers, and the major cotton and food production areas such as Huainan, southern Shandong, Kaifeng, Liuzhou, and Jianjiang. A number of key enterprises for the production of organic chemicals and synthetic materials were established in Beijing, Shanghai, Tianjin, and Changchun. Along with the discovery and development of oilfields such as Daqing, the renovation, expansion and construction of many large refineries were carried out at the Northeast, Beijing, Nanjing, Daqing, and Zibo to pave the way for the development of petrochemicals. In the late 1960's, the petrochemical industry was first developed at Fushun, Beijing, and Shanghai by using the gases and liquid hydrocarbons produced by the refineries. From the 1970's to the present is the period of great growth for China's chemical industry, and the petrochemical production, which symbolizes the level of development of modern chemical industry, has entered a new developmental stage. Since 1972, the constructions of 13 large ammonia plants that used equipment imported from abroad and natural gas, oilfield gas and light oil as feedstocks have been carried out in Sichuan, Liaoning, Heilongjiang, Jiangsu, and Hebei provinces. Meanwhile, large consolidated petrochemical facilities are being built in Yanshan of Beijing, Jinshanwei of Shanghai, the large port cities of Liaoyang and Tianjin, and Jilin. Thus, the productions of existing chemical bases are further strengthened and new bases are being opened up. The capacity of acetylene production, which symbolizes the level of development of petrochemical industry, will reach 1.4 million tons. The current actual output has already exceeded 500,000 tons.

The tremendous development in the past 30 years enables the chemical industry to attain splendid achievements. In 1983 the proportion of chemical industry output climbed to over 12 percent of the gross industrial sectors. It covers more than 20 lines of business such as chemical fertilizer, pesticide, and organic chemicals. There are over 5,000 public-owned chemical enterprises, among them over 300 are key enterprises. They produce over 30,000 products, some of them are catching up or exceed the advanced world levels and take up significant market shares. In terms of their importance, fertilizer and sulfuric acid are in third place, caustic soda fifth and chemical fibers sixth. From the distribution point of view, it has evolved from concentrating at the coastal regions to spreading throughout the country, especially that more than 10 important chemical

bases have been established in major cities and resources-rich regions. These bases are mainly focused on organic chemical industry, particularly the petrochemical industry, but each retains its own uniqueness.

#### Chemical Bases in Major Cities

Major cities have developed economy, excellent geographical locations, are important transport (oil pipeline) centers and the production centers for the greater areas surrounding them. With their rich industrial bases, favorable environments for coordinated production, strong technical forces and large market sizes, major cities have good conditions to become chemical bases. At present, the chemical bases established in the major cities include the following:

**Shanghai Base.** Shanghai is the birthplace of China's modern chemical industry and the most important comprehensive chemical base with a high concentration of large chemical enterprises. Its chemical output accounts for 12.8 percent of the national total, first place in the nation. Many products such as synthetic fibers, caustic soda, and tires are important to the nation.

Shanghai's chemical industry has grown most rapidly due to its better structure and coordination. In the past 30 years, it has grown at a rate of 16.4 percent, higher than national average and Shanghai's industrial average of 11.2 percent. Its distribution has gradually shifted from urban to suburban areas. In the early years after liberation, the chemical industry developed on the existing basis was scattered and formed a ring around the outskirts of the old city. In the 1950's, the Beixinjing and Taopu chemical industrial zones were developed, mainly to manufacture dyes, paints, pharmaceuticals and basic industrial chemicals. In the 1960's, the Gaoqiao and Wujing chemical industrial zones were opened to manufacture mainly petrochemicals and coal-based chemicals. The products included plastics, chlorine and soda ash, sulfuric acid and chemical fertilizers. In the 1970's, it spread toward the suburbs and the nationally renowned Jinshanwei petrochemical zone was established to manufacture mainly synthetic fibers and plastics.

There is a high concentration of large enterprises. Shanghai has the highest concentration of large chemical enterprises, about 12 percent of the national total. There are over 10 major enterprises including the Wujing and Gaoqiao chemical plants. They account for over 40 percent of the city's total chemical output. Due to its centralized production and matured organic chemical industry, its fine chemicals and others are distributed nationwide and it is an important export base for major chemical products.

Shanghai's chemical productions generate high economic benefits. The profits generated from each 100-yuan output and the labor productivity are both highest in the nation. It is mainly attributed to its high degree of modernized production, extensive acquisitions of new technologies and equipment, and rapid product renewal so that large output can be

realized and profitable products quickly developed. Its high quality dyes are well-known nationwide.

Beijing Base. Based on petrochemicals and the chemistry of coal-tar-derived acetylene, it is a base that produces mainly organic industrial chemicals and synthetic materials. Its chemical output account for 7.1 percent of the national total, third in the nation. Its ethylene, plastics and synthetic rubber productions are 1/2 to 1/3 of the gross national output.

Its petrochemical industry is represented by the Yanshan Petrochemical Co, the largest comprehensive consolidated enterprise of petrochemicals in the nation. Its crude refining capacity is 7 million tons per year and ethylene cracking capacity 300,000 tons per year. The major products are plastics and industrial chemicals. These bulk feedstocks and intermediate products are further processed into various types of plastic and rubber products at Beijing and other locations.

This base is unique in its unbalanced production structure. Among 16 production categories, the largest share goes to organic industrial chemicals, 58 percent of the city's chemical output. Oil refining and reagents are next, 27 percent. Basic chemicals, pesticides, and chemical fertilizers are 7 percent and so are rubber products. Therefore, there are insufficient extensive processing and precision processing.

As to the size composition, it mainly depends on large and medium-sized enterprises, which are relatively concentrated. There are 19 large and medium-sized enterprises that account for 76.8 percent of the output. The productions are mainly in Yanshan area, 60 percent of the city's chemical output. Next are the eastern and southern suburbs that are coal-based chemical industries, 38 percent. Within the city, there are only about 10 small plants that produce rubber products and paints.

Its production technology and equipment are better than other bases. In the 1950's, whole sets of coking equipment and advanced chemical technologies were imported. Polyethylene alcohol facility and the whole installation of polyvinyl alcohol fiber plant were acquired in the 1960's. The entire assembly of large-scale ethylene production and acrylic paint production equipment were imported in the 1970's. At present, those industries with modern advanced production capability account for over 50 percent of the industrial output.

Tianjin Base. Tianjin has a long-standing chemical industry that produces well balanced varieties. It is an important base of marine chemicals, fine chemicals and rubber processing. Its output accounts for 5.2 percent of the national total, sixth in the nation. Major products are soda ash, pesticides, dyes and paints.

Its marine chemical industry is well developed with a long production history. The major products are the two kinds of soda, manufactured by the three key enterprises. One of the four largest soda plants, the Tianjin

Soda Plant is located on the northern bank of the Haihe at Tanggu. It produces 27 percent of the nation's soda ash. One of the eight largest chlorine and soda plants, the Tianjin Chemical Plant is located at Weilu along the Hanguji canal. Its caustic soda capacity is 110,000 tons. The products are distributed to northern China, the south and some are for export. Also a key chlorine and soda plant, the Dagu Chemical Plant is located on the southern bank of the Haihe at Tanggu. Its products are mainly for the consumption of the nearby Tianjin area.

Fine chemicals and rubber products are important, each accounts for 37 and 28 percent, respectively, of the city's total chemical output, mainly in the forms of light textiles and agricultural services. But Tianjin lacks the basic industrial chemicals (trienes, triphenyls, ethylene glycols and synthetic rubbers) and the growth of these enterprises are greatly limited.

It consists mainly of small and medium-sized enterprises that are scattered. In 1983, there were 427 chemical enterprises, 99 percent of them are small and medium-sized enterprises, which account for 80 percent of the output. There were only four large enterprises. Fifty-five percent of the enterprises, are scattered within the city. The major products are dyes, rubber products, and chemical engineering machineries. Thirty-seven percent of the enterprises are distributed on the northern suburbs. The remainders are located in the Tanggu, Hangu areas and the Dagang area that specializes in petrochemical-based synthetic fibers.

Nanjing Base. It is located along both sides of the Changjiang at the northern suburb of Nanjing. It is a base of basic chemicals, chemical fertilizers and the newly-developed petrochemicals. At present, the important products are alkylbenzenes, sulfuric acids, and phosphate fertilizers.

The Yongliniu Plant, the then largest chemical fertilizer plant, was here before liberation. In the 1950's, the new nitrogen fertilizer plant, sulfuric acid plant and phosphate fertilizer plant were added in the Dachang township on the northern bank of the Changjiang to form a comprehensive chemical complex. Meanwhile, facilities for the production of chlorine and soda such as the Nanjing Chemical Plant were built on the southern bank of the Changjiang at Yanziji-Qixiashan area. Such key enterprises as the refinery and the Changjiang Petrochemical Plant were added in the 1960's and large enterprises such as the Qixiashan Chemical Fertilizer Plant and the Nanjing Alkylbenzene Plant were built in the 1970's. Thus, the Jinling petrochemical complex was completed. The construction of a 300,000-ton-per-year ethylene facility to manufacture mainly plastics, synthetic rubbers, industrial chemicals, and asphalts began in the 1980's. After its completion, it will supply over 600,000 tons per year of light oil rich in aromatic hydrocarbons to the Yizhen Chemical Fiber Plant.

Lanzhou Base. It is located along the banks of the Huanghe, the principal part being in the Xigu Industrial Zone at the western suburb. It is the first petrochemical base built after the liberation. It was started in the

early 1950's when equipment were imported for the construction of Lanzhou refinery as well as the production facilities for chemical fertilizers and butadiene styrene rubbers. The only medium-sized ethylene cracking facility was built in the 1960's. Through several large-scale expansions, now it includes such large key enterprises as synthetic rubber plant, petrochemical plant, chemical fiber plant, organic chemical plant, and chemical fertilizer plant. The major products include basic industrial organic chemicals such as synthetic alcohols and acrylonitriles as well as synthetic materials such as synthetic rubbers, plastics, and chemical fibers.

#### Chemical Bases at the Raw Material Production Sites

To build the chemical industries that consume lots of raw materials and energy at the raw material production sites is one way to guarantee the rapid development of the chemical industries. China's Daqing has the most abundant oil reserve and by-product gas, especially the source of condensate. The Sichuan Basin has the most abundant sources of natural gas and well salt. Southern Liaoning region has abundant sea salt, oil, natural gas, limestones and boron minerals. There are abundant coking coals and high-quality anthracites, pyrites and gypsums at Taiyuan, Shanxi and abundant lignites, anthracites, limestones, oil and water resources at Jilin. These areas rich in chemical reserves and energy resources provide sufficient raw materials and other favorable conditions for the active development of chemical industry. Therefore, chemical bases, each with its own unique features, are constructed.

Jilin Base. It is located in the Jilin municipality with the main body in the northern bank of the Songhuajiang. It is the first modern large-scale chemical base built after the liberation and is nationally renowned for the "three big chemicals"--dyes, chemical fertilizers and calcium carbide.

The Jilin Dye Plant is a comprehensive chemical producer that manufactures high-quality dyes and is the largest of its kind in the nation. Its annual output accounts for 1/10 of the national gross. The chemical fertilizer plant uses low grade coals as feedstock to produce synthetic ammonia and ammonium nitrate. In the late 1960's, it was fitted to use also heavy oil. The total capacity for synthetic ammonia is over 330,000 ton per year. The calcium carbide plant produces 1/10 of the national total. It also has a chlorine and soda production facility in the comprehensive organic chemical plant.

In order to develop chemical productions on the existing basis, the State built a large-scale refinery, an organic chemical plant and 11 facilities here including those for ethylene and butadiene styrene rubber production. It has become an important base that integrates the coal- and petroleum-based chemical industries to manufacture synthetic materials, dyes, fertilizers, calcium carbide, acetic acid, and rubber.

Taiyuan Base. Located at the southwestern suburb of Taiyuan, it is a chemical base developed earlier that uses coal as feedstock to produce

organic chemicals, basic chemicals, and chemical fertilizers. Its important products are sulfuric acid, calcium carbide, chemical fertilizer and phenol.

As early as 1936, the Xibei Industrial Co built an electrochemical plant (Shanxi Chemical Plant) at Taiyuan to produce caustic soda and chlorine. During the First 5-Year Plan period after the liberation, large enterprises such as the Taiyuan Chemical Plant, Chemical Fertilizer Plant, and Phosphate Fertilizer Plant were first established. Over 10 key enterprises including calcium carbide plant, pesticide plant, phenolic plastics plant, and dye plant have been constructed since the 1960's. And a chemical production system, based on calcium carbide and coal tar and covering chemical fertilizer, basic chemicals, mining for chemicals, pesticides, household chemicals, synthetic rubbers, and plastics, has been developed. The system of the industry is built around the subsidiary and affiliated enterprises of the Taiyuan Chemical Co, which are concentrated in the Hexi Chemical Industry Zone. There are also 13 enterprises scattered within the city.

Liaonan Base. Located along the Hada railroad line on the east coast of the Gulf of Liaodong, it is an older base of coal-base chemicals, petrochemicals and marine chemicals. The productions of soda ash, distilled naphthalene, boron mineral, and hydrochloric acid are the largest in the nation. There are eight large refineries here. Its crude processing capacity is over 1/4 of the national total, coking capacity is 1/3. Hence, it is able to supply sufficient feedstocks for petrochemicals and coal-based chemicals. In terms of distribution, the industry is most concentrated in Dalian. The Dalian Chemical Co is the largest soda ash producer, and its sulfuric acid plant, potassium perchlorate plant, paint plant, and dye plant are all rank high among their peers in terms of size. The Dalian Rubber Plastics and Machinery Plant and the Jinzhou Chemical and Machinery Plant are the key chemical and machinery plants. The Angang Coking Plant at Anshan and Yingkou Boron Mineral Plant are also key enterprises of the nation. Along with the development of the Liaohe oilfield and the laying of the Daqing oil pipelines, large facilities like the Liaoyang Petrochemical Fiber Plant were built in the 1970's. The Liaohe plant mainly produces chemical fibers, the annual output of synthetic fibers being 130,000 tons and plastics 70,000 tons.

Sichuan Basin Base. Along the Chengyu railroad and Changjiang, this is the largest comprehensive base that uses natural gas as feedstock. The major products are synthetic ammonia, vinylon, nitric acid, chloroprene rubber, dichloromethane, and carbon black.

Along with the development of natural gas and the construction of transport pipelines, a series of large and medium-sized chemical enterprises have been built at the major producing sites in the north, east and central part of the basin. Located at Naxi township on the southern bank of Changjiang, Luzhou natural-gas-based chemical fertilizer plant is the first large fertilizer plant built in the early 1960's that used natural gas as feedstock. In the 1970's, a large 300,000-ton-per-year synthetic ammonia facility was added. That makes it a key fertilizer manufacturer. The Sichuan Chemical Plant is located at Jintang on the bank of the Qingbiajiang

of the Chengdu Plain and is a large chemical fertilizer manufacturer. It has switched from coal to natural gas as feedstock since the 1970's. In addition, the Chisui Chemical Fertilizer Plant of Guizhou and the Anbian Chemical Fertilizer Plant of Yunnan have been built. As a consequence, here has the highest concentration of large chemical fertilizer plants that have significant impact on the development of agriculture. The Honghe Chemical Plant of Zigong mainly manufactures soda ash, caustic soda, and halomethanes. Furthermore, Sichuan Vinylon Plant and Changshou Chemical Plant are the key manufacturers of vinylon, methanol, and chloroprene rubber.

Daqing Base. It is located in Youfeng and Wolitun section of Daqing along the Binzhou railroad. Along with the massive development of oil, key enterprises such as Daqing Petrochemical Plant and Wolitun Chemical fertilizer Plant of Daqing were built on the foundation of the existing large refineries in the 1960's. They mainly manufacture petroleum products, acrylic fiber and chemical fertilizer. In the 1980's the construction has been carried out for Daqing ethylene complex, which includes 11 facilities with 300,000-ton ethylene, 140,000-ton polyethylene and 70,000-ton acetic acid capacity. It will become a large complex that produces 265,000 tons of plastics, 250,000 tons of industrial chemicals, and 50,000 tons of chemical fibers per year. It is becoming a new petrochemical base of the country.

China's chemical industry is growing stronger every day and the production bases are increasing in number. Besides those mentioned, there are the growing Zibo petrochemical base and Yueyang petrochemical base that mainly manufactures chemical fertilizer, synthetic rubber, and synthetic fiber.

12922/9190  
CSO: 4008/1086

## NATIONAL DEVELOPMENTS

### PETROCHEMICAL COMPLEX EAST OF DAQING ESTABLISHED

Beijing LIAOWANG [OUTLOOK] in Chinese No 24, 16 Jun 86 pp 27-28

[Article by Kang Weizhong [1660 0251 0022] and Wei Guozhi [7614 0948 1807]]

[Text] On the northern border of China east of Daqing oilfield, a modern petrochemical complex occupying nearly 10 square kilometers of land is taking shape. Its unique structures standing tall on an open wasteland, this is the 300,000-ton large-scale ethylene facility of Daqing with a total investment of 4.2 billion yuans. At present, the phase one project of putting in place five sets of large petrochemical installations is basically completed and is at the preparation stage for test-run. It will become the first key national project to be put into production during the Seventh Five-Year Plan period.

Entering this petrochemical complex and looking around, one finds a strange world consisting of towers, pipes and tanks, a quite different vista from large modern facilities with rows of plants. Three layers of suspending and densely-packed pipelines stretch afar like a stream. Three towers reaching into the sky overlook the complex like giants and coordinate with some 130 towers of various installations from afar. After going into operation, they will send hundreds of thousands tons of plastic pellets in a steady flow to all over the country.

When the whole construction is completed, it will provide about 560,000 tons of industrial organic chemicals, plastic pellets and acrylic fibers and will have a significant impact on developing China's chemical, textile and plastic industries, changing China's industrial structure, and enhancing the development of the national economy. Take the revitalization of Heilongjiang's economy as an example. The feedstocks supplied by the Daqing ethylene complex have made possible the continuing constructions and expansions of tens of small and medium-sized chemical, plastic and textile plants in the province. They process part of the feedstocks locally to provide the local markets with a variety of textile, plastic and chemical products as well as membranes for agricultural uses, medicines, pesticides, and new construction materials. These will have a significant impact on revitalizing the petrochemical businesses of the country, improving the economic structure of Heilongjiang, stimulating the growth of light textile industry, and serving the material and cultural needs of people better. Now, this huge project, like a healthy baby kicking impatiently inside its mother for some time, is born full of vigor and vitality.

## Its Mother: the Daqing Oilfield

The 300,000-ton ethylene facility at Daqing is the first huge consolidated petrochemical plant in China using the crude oils from oilfield and the light hydrocarbons isolated from natural gas. Therefore, one can say that Daqing oilfield is its mother. However, the breeding process takes a long period of time.

Since 1960, when the Daqing oilfield was being opened up in the great battle for oil, it has been discovered that more and more gas are produced along with the pumping of crude oils. This byproduct gas is a gas rich in organic materials. It would be a waste to use it simply as an industrial or household fuel. In addition, the gas production was so huge that the surplus not consumed by the vast compound of the Daqing oilfield was fed into a torch and burned away. In the meantime, the light oil from the crude was evaporated because of inability to recover. Under the circumstances, the provincial government of Heilongjiang and the former Ministry of Petrochemical Industry sent a report to the State Council advocating the rational tapping of the oil and gas resources of Daqing so that they can be fully utilized. For this reason, the State Council proposed, as early as in 1970 in its meeting minute No 10, the construction of a large petrochemical plant in the Daqing oilfield.

However, how much and how long can the Daqing oilfield supply oil and gas for a large modern petrochemical plant are the questions that have to be addressed first. After nearly 4 years of investigation, it was confirmed that Daqing oilfield has an abundant reserve of natural gas, the total annual output being over 2 billion cubic meters. Together with the light hydrocarbons isolated from the crude, they can completely provide the ethylene plant a stable, long-term supply of sufficient feedstocks.

Besides the supply of feedstocks, the problem of water supply also had to be solved. Although Daqing oilfield is located in the central part of the Songliao Plain, there is no river nearby so ground water is in short supply. Without water supply, it is impossible to build a large-scale petrochemical plant. The provincial government of Heilongjian mobilized tens of thousands of laborers and through several years of hard work to complete the huge diversion project, which diverts the Nenjiang water several hundred li away at the western part of Songnen Plain to the Daqing oilfield. Thus the water supply problem is solved.

To build a large-scale ethylene plant in Daqing, it would be necessary to handle from hundreds of thousands to over a million tons of materials and chemical products each year. The transportation problem is extremely critical. In the past, the only single-track railroad passing through the Daqing oilfield was not sufficient to take on such a heavy load. Through the active cooperation of the railroad department, it was converted into a multiple-track line. Thus, the transportation problem is solved.

On the aspect of technical manpower, a large-scale synthetic ammonia fertilizer plant and China's first small 500-ton petrochemical plant have

been constructed successively in Daqing oilfield since 1970 and hence a technical force has been assembled, trained and management and foreign affair experience attained in preparation for the construction of large-scale petrochemical plants.

After 7 years of preparation, the external conditions were ripe for the construction of a 300,000-ton ethylene plant. During this period, the goal of constructing the ethylene plant remained unchanged even though there was a drastic change in political situation. On 2 September 1977, the State Council formally approved the project. In 1978, talks with foreign businesses to import equipment began. In 1979, the headquarters for the ethylene project were established. In the same year, construction teams moved into the construction site and started laying underground pipes. In November 1980, the State decided to postpone the Daqing ethylene project as the needs of national economy changed. In April 1981, it formally decided to halt the construction. During this period, experts from national organizations carried out two technical assessments on the 300,000-ton ethylene project at Daqing and concluded that the project would be beneficial. In September of the same year, the State Council reversed its decision. In April 1982, the ethylene project resumed and was being carried out in full swing.

#### Cause for Construction Workers, Authority of Supervisors

Since the construction of the Daqing 300,000-ton ethylene project was resumed in 1982, 39 construction teams from all over the country, totaling 50,000 strong, have arrived at the site. They said with pride: "We are doing the national key project. We are here not only to finish the job, but also for the cause of the modernization of socialism." They put national interests first and were highly cooperative. They were closely coordinated throughout the construction and have overcome many difficulties and fought one after another those difficult yet triumphant battles to finally put up the "giant".

At the construction site, the project headquarters have won the admiration of the leaders and workers of construction units from all over the country. They all accept the leadership of the headquarters willingly. They said: "The headquarters have the authority." Where did the authority come from? At a meeting of the leading cadres from all construction units, one supervisor said: "According to the contract, we are equal partners. But we represent the State here, and we say what we have to say." The supervisors at the ethylene project headquarters put national interests first and exercised solid control over individual construction unit in a highly responsible manner and each construction unit expressed its firm commitment to follow this strong leadership, thus enabling the over 30 construction teams to be pulled together and to act in one mind like twisting threads into a rope.

Authority came from reasonable leadership. The supervisors believed that a large-scale staggered construction like the 300,000-ton ethylene project required a systematic, comprehensive planning and logical execution of the construction. Based on the requirements of the general deployment and overall network planning, they focused on the principal contradiction,

decided the control points and set forth the campaign strategy. They also broke up the major control targets for each task into smaller control targets and concentrated forces to overpower them one by one and accomplished a total success. At that time, many did not believe that the ethylene auxiliary boiler could become operational within such a short period of time. Amid the surprise and excitement when the auxiliary boiler was successfully ignited, people realized the great power of guiding the construction logically.

The authority of the supervisors also came from their presence at the site. Throughout the construction, each important task was headed by a supervisor, who ate and slept at the location and directed from the construction site. Deputy supervisor Wang Ying [3769 5391] of the project headquarters commented: "We feel extremely proud and honored to be able to participate in such a big project in our life time. For the project, we dare to shoulder all heavy burdens."

#### Even Foreign Experts "Shaped Up"

The first five sets of chemical engineering installations came from Japan, Federal Republic of Germany, England and the United States. In order to install properly these higher-level modern chemical engineering equipment, 297 foreign experts came to assist in the installations as called for in the agreements.

In order to bring into play the initiative of the foreign experts so that they could better help us install and test various equipment, the project headquarters had actively involved in creating favorable working conditions for them, taking care of their daily life and treated them sincerely like brothers. Our friendship with a Japanese expert, Mr Tsukahara, flourished because of his deeper understanding of Chinese people. There was the case of a large quantity of firebricks imported was stored over an extended period of time and should not be used according to the specifications. Mr Tsukahara understood our being thrifty in spending foreign exchanges. He spent lots of time and actively cooperated with us to test the various kinds of firebrick stored at different locations. After examining all the data, he reached the conclusion that a majority of the bricks could still be used, which saved us a substantial amount of foreign exchange. An old expert from Germany, Mr Gothes, was so moved by our sincerity and friendliness that he wore the working clothes everyday and often was soiled all over with grease. During the installations, he would solve problems personally be it as large as various technical problems or as small as a screw. In the pressurization test of an equipment last year, he ignored the danger and supervised in person at the site to ensure the smooth conclusion of the test.

Because we made friends with these foreign experts and treated them sincerely, a majority of them had actively tried to solve problems encountered. When information was incomplete, they actively tried to get them. When parts were damaged, they actively contacted the manufacturers at home to make new shipments. Some even carried the urgently needed parts personally from

abroad. One supervisor from the project headquarters remarked that these foreign experts played an irreplaceable role in the construction.

### The Wish Is Becoming Reality

The Party Central Committee and the State Council have been very concerned with the construction of the 300,000-ton ethylene project. When the project was approved in 1977, Comrade Li Xiannian instructed that it should be done quickly and properly. During his visit in September 1978 to the Daqing oilfield, which was at that time a barren plain dotted with a few simple camps as the site of construction, Comrade Deng Xiaoping said wishfully: "I will come again when the construction of ethylene project is completed." When the ethylene project was put on hold in 1980, Premier Zhao Ziyang visited the site and commented: "The project is under favorable terms, the construction shall be continued." In August 1982, Comrade Hu Yaobang visited the construction site of ethylene project and suggested that "the 300,000-ton ethylene project at Daqing must be completed on schedule without compromising the specifications and quality."

Now, the wishes of the leaders at the Party Central Committee and of the State are gradually becoming reality.

At present, the Daqing ethylene project formally enters the preparation stage for trial runs and soon will reach the stage of test production.

We warmly congratulate the birth of the Daqing 300,000-ton ethylene consolidated facility.

A view of the phase I construction of the Daqing ethylene project.



The central control room of the Daqing ethylene project.



12922/9835  
CSO: 4008/1089

## NATIONAL DEVELOPMENTS

### 30 YEARS OF NATIONAL SPACE ENDEAVORS REVIEWED

Beijing HANGTIAN [SPACE FLIGHT] in Chinese No 2, 27 Mar 86; No 3, 27 May 86

[27 Mar 86 pp 2-3]

[Text] Decision To Develop Rocket Technology

In the 1950's, many of the major nations in the world had entered the so-called "atomic age" and "jet age." The Chinese Government, realizing that it was impossible to support our national defense by relying on weapons purchased from other countries, decided to dedicate the nation's top priority to defense modernization.

At that time, with China's backward economy and very weak industrial base and technical capabilities, we could only devote our limited human and material resources and funds to the most important and most urgent projects; therefore, the Communist Party and the state decided to give first priority to the high-technology issues of guided missiles and atomic energy. To carry out this task, Chairman Mao Zedong, Premier Zhou Enlai and other high officials conducted their own investigations and research by soliciting the opinions of many well-known Chinese scientists. For example, in April 1956, Premier Zhou Enlai held a meeting of the Central Military Commission, where he invited the recently returned rocket expert Qian Xuesen to outline his plan for developing China's missile technology. The decision by the state to develop missile technology provided an important impetus for the defense community and had significant strategic implications for China's defense construction and technology development.

In order to provide organizational leadership in carrying out the plan of rocket and jet engine development, the Commission on Aviation Industry (CAI) headed by Nie Ronzhen was established in April 1956. In May, Zhou Enlai held another Central Military Commission meeting during which a report presented by Nie Ronzhen, "Preliminary Concept of China's Missile Research," was discussed. The Commission authorized CAI to establish the Missile Management Bureau and the Missile Research Institute for the Ministry of National Defense. The two organizations housed in two old clinics and an old hospital, and 30 technical experts and over 100 graduating college students were recruited. This small team of technical staff was the backbone of China's first missile development force.

On 8 October 1956, China's first missile research organization--the No 5 Research Institute of the Ministry of National Defense was officially established. To minimize the levels of bureaucracy, in 1957 the Central Military Commission decided to merge the Missile Management Bureau into the No 5 Institute of the Ministry of Defense.

In December 1957, based on the needs of missile research, the No 5 Institute combined its 10 research offices into two divisions, which were respectively charged with the responsibilities of conducting research in missile body, propulsion and guidance and control system. In February 1958, the Office of Electronic Research, which was a part of the Department of Military Communications, was also assigned to the No 5 Institute. During this period, Premier Zhou Enlai appointed Qian Xuesen to be the director of the No 5 Institute.

#### Developing the First Modern Rocket

In September 1960, as a test of the engineering facilities of China's first missile launch site, we successfully launched the Soviet-made P-2 missile using Chinese-produced rocket fuel and Chinese operational personnel. On 5 November 1960, China successfully launched the first short-range missile. In December of the same year, we conducted two successful tests of the Chinese-made P-2 missiles.

The success in building a copy of the P-2 missile indicated that a significant stride had been made by China in missile technology. Since that time, China possessed its own short-range missile.

As the copied P-2 missile was about to be released, a request was made by Vice Premier Nie Rongzhen to the No 5 Institute to develop a missile of our own design. This was quite a challenge for this young research team.

But the entire staff of the No 5 Institute accepted the challenge with great enthusiasm; they were determined to overcome the difficulties resulting from lack of experience and foreign sanctions by dedicated hard work and by learning on the job. Answering the call of the motherland, everyone worked day and night in manufacturing, production, testing as well as in the design of various subsystems and prototypes. Within a period of little over a year, the first batch of test rockets had been built.

On 21 March 1962, the first Chinese-designed rocket was scheduled for its first flight test. Unfortunately, because of a malfunction in the control system and fire in the engine, the rocket was destroyed near the launch pad. Naturally, everyone was deeply disappointed.

However, they soon recovered, and having learned a lesson from this failure, they were ready to start over again. By carefully studying the problem areas revealed by this test, they modified the overall design and conducted extensive research on each of the subsystems. The modified rocket was subject to 17 major ground tests until all technical problems had been solved, and the technical staff were fully confident about the upcoming test.

On 29 June 1964, the first Chinese-made intermediate-range missile was launched, and the test was a success. This test marked a new page in the history of China's missile and rocket development. Subsequently, between July and October of that year, we repeated the launch test a number of times, and every test was a success.

#### Nationwide Cooperation

As early as 1959, Vice Premier Nie Ronzhen had predicted that in order to develop high technologies in this country, we must first develop our own capabilities in new raw materials, electronic components, instruments and gauges, precision machineries, large-structure facilities, and testing and measurement techniques. For this reason, he made the suggestion of organizing a nationwide cooperative effort to develop new materials, new components and new facilities; this suggestion was approved and supported by the Central Committee and Chairman Mao Zedong. Then, a unified plan across the nation was established to meet the requirements of missile and rocket development, and various research and development tasks were assigned: the task of developing new rocket fuels and sealing materials was assigned to the chemical engineering department; the task of developing high-temperature materials, light metal alloys, electronic components, and electric vacuum devices was assigned to the metallurgical department, the Chinese Academy of Sciences and the electronic engineering department; the task of developing precision bearings, precision machineries, special-purpose vehicles and launch facilities was assigned to the mechanical engineering department; and the task of developing non-metallic special materials was assigned to the construction material department. Thus, the development of high technologies in the defense industry also stimulated efforts in the basic research of new materials and new techniques, and raised the technical standards of those departments which contributed to the overall economic growth of this country. The development of China's materials industry, electronic industry and precision machinery and instrument industry not only filled the void in many of China's scientific fields but also contributed to the establishment of a cooperative network to support the development of high technologies and to provide the material and technical basis for developing China's own capability in missile and space technology.

At the time when China was ready to design its own liquid-propellant rocket, there was a movement emphasizing the importance of basic research, and many basic research projects were planned. During the early 1960's, in order to meet the needs of developing intermediate-range missiles, intensive research activities were initiated in such areas as liquid-propellant rocket engines, rocket structures, on-board computers, inertial devices, servo mechanisms, remote-sensing technologies, ground equipment aerodynamics, environmental testing, materials technology, test measurement, and electronic components; the important breakthroughs in many key technology areas led to a solid foundation for new missile development. To carry out the large number of of research programs described above, the No 5 Institute was joined by the Chinese Academy of Sciences, the various engineering departments, the higher institutions and the local research organizations.

## Establishment of the Seventh Ministry of Machinebuilding

In December 1964, a resolution was passed during the first meeting of the Third People's Congress to establish the Seventh Ministry of Machinebuilding. This new ministry was formed by using the No 5 Institute of the Ministry of Defense as a core, and by consolidating several factories and offices from the Third, Fourth and Fifth Ministries of Machinebuilding as well as from other departments and provincial and municipal governments. It was charged with the responsibility of managing the research, design manufacturing, production and basic development of the missile and rocket industry. In January 1965, Chairman Liu Shaoqi appointed Wang Bingzhang to be the director of the Seventh Ministry of Machinebuilding.

With the establishment of the Seventh Ministry of Machinebuilding, the development of China's missile and rocket technology entered a new era where major changes in organizational systems took place, the scope of development was expanded, and the conditions for research and development were improved. The expanded research and development activities included: multiple missile models, full-scale development of both strategic and tactical missiles, solid-propellant rockets as well as liquid-propellant rockets, and medium-range, intermediate-range and inter-continental rockets. The basic research projects initiated during the early 1960's began to bear fruit in terms of enhanced technical capabilities for developing new missile models. In addition, the design experience and organization and management experience acquired in developing short- and medium-range missiles created favorable conditions for accelerated development of missile and rocket technology.

Under these circumstances, the well-known scientists Qian Xuesen and Zhao Jiuzhang who had proposed the development of artificial satellites each submitted a written statement to the Central Government suggesting that development of China's space technology should be accelerated. In May 1966, an agreement was reached between officials of the Defense Technology Commission, the Chinese Academy of Sciences and the Seventh Ministry of Machinebuilding to develop China's first artificial satellite which will be named "East Is Red 1"; the carrier rocket will be named "Long March 1." They planned to launch the first satellite in 1970.

For historical reasons, the development tasks of China's first satellite were scattered among the Chinese Academy of Sciences and the Seventh Ministry of Machinebuilding, thus creating a very difficult problem in organization and coordination. To rectify this situation, the Chinese Space Technology Research Institute was established on 22 February 1968; its charter was to participate in the planning of China's space development, to verify the technical performance of spacecraft, and to carry out the research, design, production and testing of spacecraft, as well as to coordinate the operations of carrier rockets, launch facilities and ground command and control. In July 1973, it was officially merged into the Seventh Ministry of Machinebuilding.

[27 May 86 pp 2-3]

[Text] Sounding Rocket

The primitive launch facility for the T-7M rocket was located on an open field 2 km east of Lao Gang Village in Nan Hui County, Shanghai. The power plant was a straw hut covered with a sheet of oil cloth; its 50-kw generator was borrowed from someone else. The power plant was only 100 m from the launch pad and the "Command Post," but they were separated by a small river. With no telephones, no walkie-talkies, no loud speakers, the commander had to issue commands by shouting or by using hand signals. With no pumping equipment, a bicycle pump was used as a pressure source for filling the propellant. With no automatically steered antennas, a manually-operated antenna was used to track the rocket.

On 19 February 1960, a T-7M rocket stood straight on a 20-m tall launcher. With a loud roar of the engine and a burst of white-hot flame, the rocket lifted upward along the guide rail, and headed straight toward the sky. This marked the first successful launch of China's liquid-propellant sounding rocket. Then, in September 1960, the first liquid-propellant weather rocket, the T-7 was also launched. Today, a variety of different types and models of sounding rockets have been developed. They include the T-7, the T-7A (first generation), the Peace No 2 (second generation), the Peace No 6 and four different types of 761 (third generation) weather rockets which are under development, two biological test rockets, the T-7A(S<sub>1</sub>) and Ta-7A(S<sub>2</sub>), and three different types of space technology experimental rockets the T-7A(YS).

The Peace No 6 is a single-stage solid-propellant weather rocket; its maximum diameter is 0.1615 m. The composite model weighs approximately 60.8 kg, and is capable of carrying 2.8 kg of instruments to an altitude of 60-80 km. The drop-ball model weighs approximately 58 kg, and is capable of carrying 2 kg of instruments to an altitude of 70-90 km. It is used to measure atmospheric temperature, pressure, density as well as wind speed and wind direction.

The T-7A(S<sub>2</sub>) biological test rocket has a maximum diameter of 0.6 m and a lift-off weight of 1,346 kg; the 170 kg payload can accommodate 1 dog, 4 white mice and 12 test tubes containing fungi, ray fungi, and mycetome. On 15 and 28 July 1966, two dogs named "Xia Bao" and "Shan Shan" were launched by the T-7A(S<sub>2</sub>) rocket to a high altitude and safely returned to ground.

The T-7A(YS) high-altitude-ignition experimental rocket was successfully launched on 8 August 1968. It had a lift-off weight of 1,378 kg and can reach a maximum altitude of 311 km.

#### Liquid Propellant Rockets

China's carrier rockets were developed as part of the ballistic missile development program. Over the years we have developed four different carrier rockets: the Long March-1, the Long March-2, the Storm-1 [Fengbao] and the Long March-3.

In September 1971, the first successful test of an inter-continental rocket was conducted at the Jiu Quan launch site. In 1977, China decided to launch a long-range rocket toward the Pacific Ocean region in 1980. Contributors to this test included more than 30 departments, committees, and bureaus of the State Council, the Chinese Academy of Sciences and selected higher institutions, the headquarters, the Navy, the Air Force, and the second artillery unit of the People's Liberation Army, as well as different offices of the 27 provinces, cities and autonomous regions. Several tens of thousands of engineers, technicians and military commanders from more than 1,000 factories, research offices were determined to complete all the preparation work before the target date: 24 hours, 31 December 1979.

It was a spring morning in 1980, the launch field was flooded with lights; a huge milk-white rocket embraced by the launch tower stood silently in the Gobi Desert. The operating personnel, like sentinals ready for an attack, waited patiently for the arrival of the launch time.

Then the ignition command was given. The huge rocket emitted a deafening roar that shook the earth, and lifted straight up. In a few minutes, it traveled across the sky and headed toward the southeast.

At the impact region in the Pacific Ocean, a few patches of white clouds floated across the unlimited sky. On the calm ocean surface, several receiving ships and recovery boats flying the 5-star flag stood ready. On the ship decks and at the control platforms, people were anxiously awaiting the rocket to arrive from the mainland.

Suddenly someone shouted "the target is detected," and everyone turned their heads toward the northwest. They saw a bright spot emerging from the clouds. Then, with a flash, it turned into a fireball. Shortly afterwards, the fireball dispersed into many bright spots; one of the bright spots became larger and larger, and began to develop a bright tail trailing behind. With a big bang, the recovery module was ejected, and a parachute opened. Finally, it splattered into the ocean, creating a column of water 100 m high. A helicopter approached the impact area, and while hovering 30 m above the water, diver Liu Zhiyu descended the rope-ladder and jumped into the ocean; he quickly grabbed the recovery module, and like holding a new-born baby, climbed back into the helicopter. A total of 14 minutes had elapsed since detection of the target; and the recovery process only took 5 minutes.

#### Solid Propellant Rockets

China devoted 10 years of exploratory work to develop its own solid-propellant rocket technology. Since the late 1960's, a number of solid rocket engines designed for tactical missiles and space vehicles had been developed; they include the 3d-stage engine of the Long March-1 carrier rocket, the retro engine for retrievable satellites, and the apogee engine used on an experimental communications satellite.

In the early days, the secrets of solid rocket technology were closely guarded by other countries. The ingredients of solid propellant were only known to contain a solid oxidizer and a bonding agent which was used as fuel. The oxidizer was considered to be potassium perchlorate and ammonium perchlorate; but there was no information on the bonding agent. In this country, knowledge about the key ingredients was practically non-existent. Only through the efforts of a team of young pioneers digging through foreign literature and piecing the puzzle together that a general concept of building a solid-propellant rocket gradually took shape.

The research work began with the raw materials. But due to the lack of experience, ignorance about the danger of composite propellants, and poor working conditions, many pioneers sacrificed their lives during the exploratory work. On 6 December 1962, while filling propellant into a 300-mm engine, the fuel mixture ignited and exploded, killing Chen Sumei, Han Yuying instantly, and critically injuring Wang Zhenkao, Liu Enke, who later also lost their lives.

In 1967, an order was issued by high officials to develop a large solid rocket engine. During the process of developing a prototype engine, many technical difficulties were encountered, including the problem of bonding separation between the fuel and the shell structure, the sealing problem, and the problem of structural strength. Thus, developing a reliable rocket engine was in the critical path of solid rocket development. On 16 March 1974, director of the Propellant Accessories Factory, Wang Lin, returned to the shop after work to try out a very dangerous mixing procedure. While operating the horizontal mixing machine, the propellant exploded, demolishing the steel-reinforced protective wall and killing comrade Wang Lin.

The Mohaupt fusing cable used for stage separation was also a key element in rocket testing. Because of inadequate assembly and test facilities, a batch of fusing cables were manufactured by hand, and the first full-scale stage separation test carried out by hanging the test article on a large tree in an open field. The development of the Mohaupt fusing cable was a technical breakthrough in stage separation of China's multi-stage rockets.

#### The Long March-3 Carrier Rocket

The Long March-3 is a multi-purpose 3-stage carrier rocket. It is 43.25 m long, and has maximum diameter of 3.35 m; its lift-off weight is approximately 202 tons and its lift-off thrust is 280 tons. The third stage is a high-energy, low-temperature, liquid-oxygen and liquid-hydrogen engine.

Liquid hydrogen has a boiling point of 253°C below zero; it also has a low density and a low heat conduction coefficient, small surface tension, and low coefficient of viscosity. Its leakage rate is 50 times as high as that of water. Under standard atmospheric pressure, a tiny spark will ignite a mixture containing as little as 4 percent hydrogen and result in an explosion.

The hydrogen-oxygen engine was introduced in the 1960's; while its performance is superior, there are many difficult technical problems associated with it. For example, if the liquid hydrogen tank is not adequately insulated, the liquid hydrogen will evaporate rapidly, causing the tank pressure to rise which may lead to an explosion. If a small amount of air exists in the fueling tube, the nitrogen and oxygen in the air will solidify as the temperature drops sharply; then any vibration during the engine operation will produce sparks due to friction between the solid particles and create a strong explosion. There are also numerous other technical problems.

Thanks to a nationwide cooperative effort, the Long March-3 carrier rocket was born in 1984.

#### Swift Action

The Long March-3 rocket was flight tested for the first time on 29 January 1984, where a satellite was launched into a 6,000-km elliptic orbit. Although this flight test was a success, it also revealed a number of weak links of the design. In order to launch an experimental communications satellite into a geosynchronous orbit, these weak links must be carefully reviewed and the problems must be resolved before launch.

The weather in April is nice and calm in the great southwest, but after April the weather begins to change rapidly. Therefore, if one misses the "launch window" during April, the launch must be postponed by 1 year. Faced with this time-critical task, this team of 20-year veteran rockets builders accepted the challenge.

On 30 January, both the launch site and the research base organized special teams to analyze the weak links and to suggest methods of solution. The data collected by the receiving ships were sent via the highest priority route to the hands of the key personnel, who performed analyses, computations and experiments around the clock in order to determine the cause of the problem. Then, a group of designers gathered to pool their wisdom together to arrive at an improved design; production of the test parts was started immediately and tests were scheduled. Two months of work was completed in 15 days.

By 1 March, two different measures of improvement had been introduced, but the chief designer of the communications satellite program, Ren Xinmin, still felt uncomfortable; he preferred to have a third measure of improvement implemented. But time was running out. After careful consideration, it was decided to go ahead with the improvement. To race against time, two teams were organized; each team worked day and night and completed the design, production, and testing in only 4 days and 3 nights.

On 22 March, the redesigned parts were shipped to the launch site; on 23 March they were installed on the rocket which was already standing on the launch pad. The installation was difficult because the engine compartment was

filled with delicate parts and conduits; the three technicians could only work in a crouched position, nevertheless, they completed the work in 4 days.

On 8 April 1984, the Long March-3 rocket successfully launched a 1,430-kg experimental communications satellite into a geosynchronous orbit, which proved that China was now one of the advanced nations in the world in terms of carrier rocket technology.

3012/6662

CSO: 4008/84

PHYSICAL SCIENCES

A COMPARISON OF SEA SURFACE TEMPERATURE PATTERNS BY REMOTE SENSING SATELLITE WITH THAT BY SHIP MEASUREMENTS IN THE HUANGHAI SEA AND THE BOHAI SEA

Beijing HAIYANG YU HUZAO [OCEANOLOGICA ET LIMNOLOGIA SINICA] in Chinese Vol 16 No 5, Sep 85 pp 347-353

[Article by Peng Chengji [1756 2110 1015] of the Shandong College of Oceanology, Qingdao and R.L. Bernstein of the Scripps Institution of Oceanography, U.S.A.: "A Study Comparing Sea Surface Temperature Patterns From Satellite with that From Ship Data in the Huanghai and Bohai Seas"\*]

[Text] English abstract: The Huanghai Sea (Yellow Sea) and the Bohai Sea are very shallow waters and partly enclosed by continent. In this area variations in water temperature, especially surface temperature, are so complicated that the isotherms of surface temperature from ship data are not synoptic.

In this paper the SST patterns from AVHRR are compared with that from ship data, and it is found that generally in the periods of rather stable surface temperature, like in February and March, and possibly August and September, the isotherms from ship data are reliable practically, otherwise will be distorted, especially when surface temperature rises up or falls down rapidly.

A feasible method of combining satellite with buoy or ship is proposed to obtain real synoptic SST patterns. [End of abstract]

Conventional sea temperature measurements are carried out on board ship. The precision of temperature measurements made from a ship is comparatively high, but due to the limitation of the ship speed, complete measurements in one region of ocean requires up to 10 days or more. The measurements from each of the measurement sites are obviously not simultaneous. Drawing the isotherm distribution with these non-simultaneous measurements, is it possible to represent the true situation of the ocean region? Especially when considering those more complicated ocean regions with changing water temperatures, the problem takes on greater significance.

---

\*This work received the support of the head of the Scripps Institution of Oceanography, Dr W.A. Nierenberg. When collecting the ship measurement data, we received the help of comrades Qiu Daoli [6726 6670 4539], Gao Yanchang [7559 6056 2490], Zhou Shilai [0719 6108 6326], and others of the Huanghai sea products research office, Aquatic Products Science Research Institute. For this, we express our gratitude.

Paper received on 3 March 1984

The Yellow Sea and the Bohai Sea areas in the western periphery of the Pacific Ocean, bounded on three sides by land, taken as typical of a shallow sea continental shelf, have much runoff entering the water. The water temperature is strongly influenced by the mainland climate and groundwater characteristics which cause complicated changes. Especially the surface layer water temperatures can be changed by temporary factors (for example, storms), aside from the large daily and weekly variations. In 1 day, the maximum variation in the surface layer water temperature could be as much as  $11.9^{\circ}\text{C}$ [1]. In this kind of ocean area, a few ships with just site by site measurements have drawn surface layer isotherms and their representivity is open to doubt. As an example, there is the famous "double ship" experiment[1]. Figures 1A and 1B show totally nonconforming sea surface temperature maps the features of which were obtained by two ships in the same ocean area, simultaneously following opposite navigational routes.

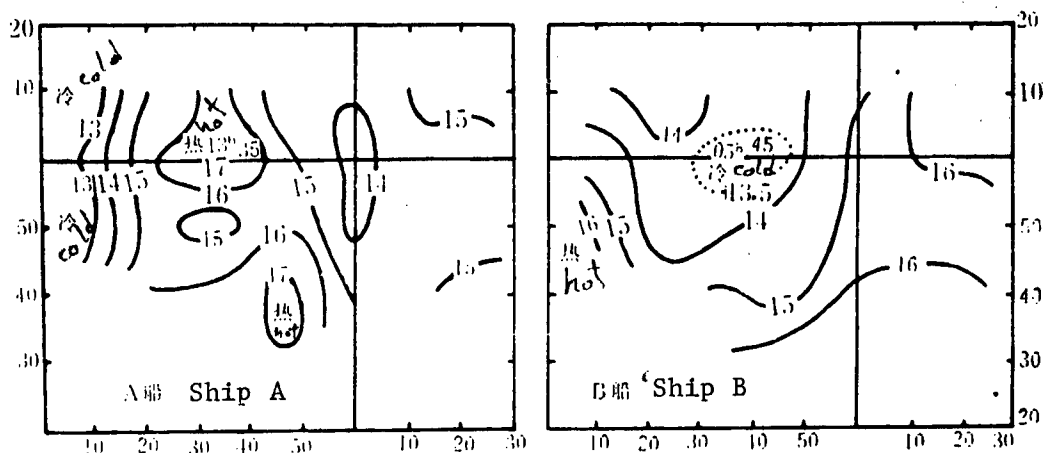

Figure 1: Comparison of the distribution of surface layer water temperatures from two ships (taken from reference [1])

Although ship measured isotherms can be subject to varying degrees of distortion, the difficulty is that, within the limits of a large area, if you cannot carry out true "simultaneous" measurements, then you cannot obtain a distortion-free temperature model. As a result, there is no way to determine the degree of distortion in ship measured isotherms.

Remote sensing satellite technology has the capability for "simultaneous" or "quasi-simultaneous" (in nearly the entire measurement stage, changes in the object of measurement can be neglected as immeasurable) measurements of sea surface temperatures over a large area of ocean. The sea surface temperatures referred to here are actually the radiation determined temperatures of an ocean surface "skin layer" of approximately a few tens of microns in thickness. Although this temperature and the usually referred to ship measured temperatures are not the same thing, the difference between the two cannot be very large. Some references now report that the difference is within  $0.5^{\circ}$ [3]. Moreover, due to the synchronous properties of measurements by remote sensing, they can supply a closer and more accurate sea surface temperature pattern of an entire ocean region. This work compares the pattern of sea surface temperatures (SST) obtained via the TIROS-N and NOAA-6 satellites with simultaneous

ship measured isotherms. This not only clarifies the reliability of the results of satellite infrared remote sensing surveys, but also demonstrates the limitations of ship measured isotherm diagrams. Finally, we propose a type of satellite-buoy (or ship) combined method to solve the problem of daily measurements for sea surface temperature maps.

### Ship Measurement Data

We first selected a period from March to May when the monsoons were changing from north to south and water temperatures range from stable to sharply rising to carry out our research.

Ship measurement data originated from a total of 90 measurement sites from south 35°N to east 124.5°E. Figures 2 and 3 differentiate between 1979 and 1980 ship measured sea surface temperature maps. We further distinguish among the three selected test sites (A,B and C) which are the northern, middle and southern sections of the Huanghai Sea. Based on the data of these three test sites, we sought a generalized understanding of the characteristics of sea water temperature changes in the Huanghai Sea and the Bohai Sea.

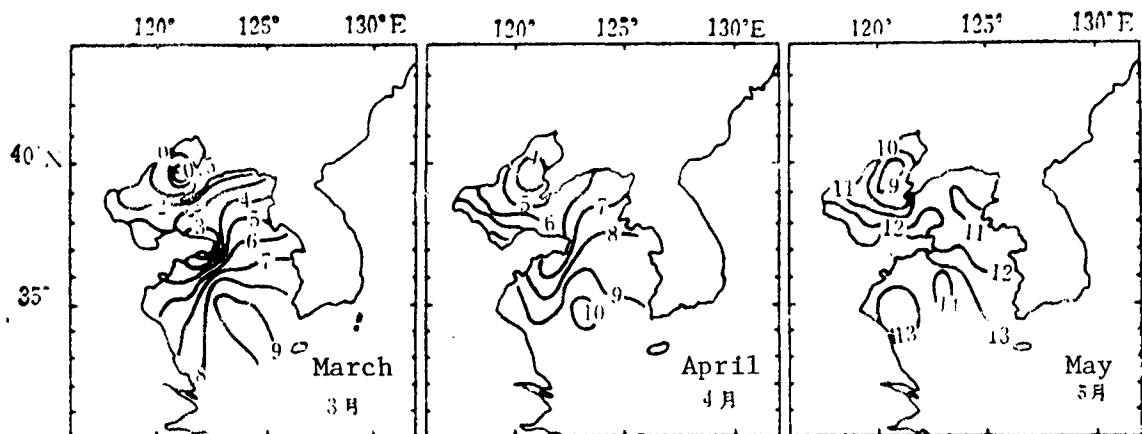

Figure 2: 1979 ship measured sea surface isotherm map

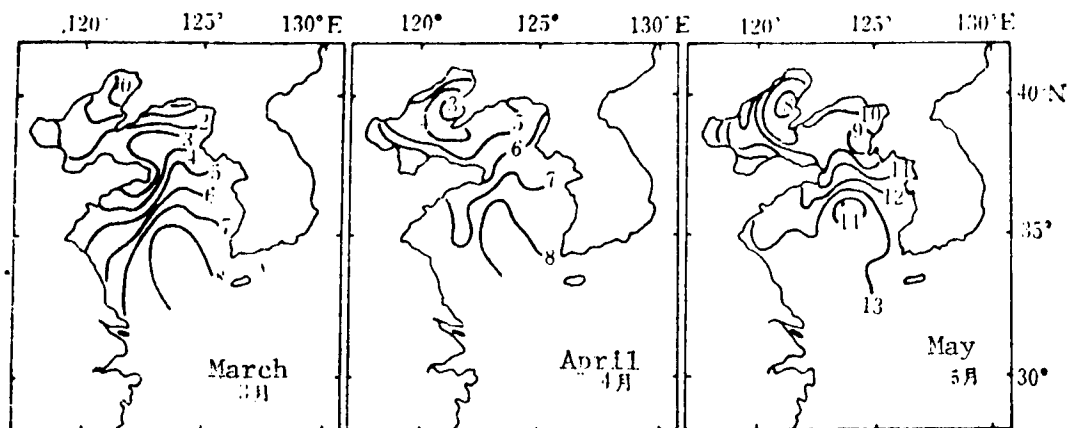

Figure 3: 1980 ship measured sea surface isotherm map

Figure 4: Temperature changes with depth at 3 measurement sites

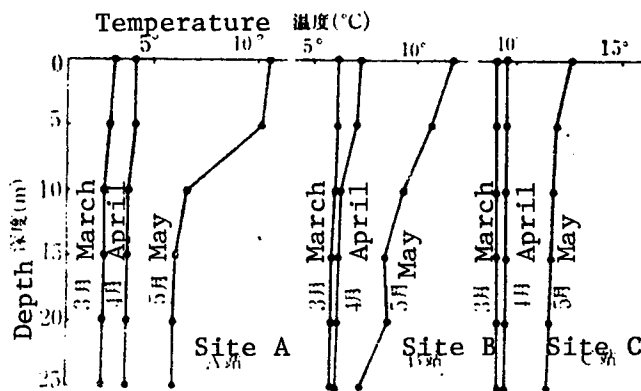
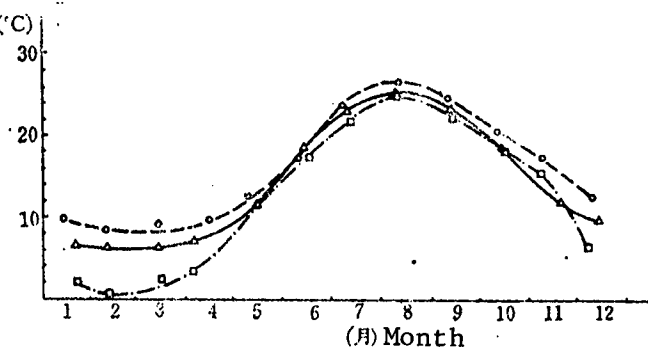

Figure 4 shows the change in temperature with depth at the three test sites. In March and April, the sub-surface temperatures were evenly distributed. In May, the surface water temperatures appear to rise; moreover, as you go north (where the water becomes more shallow), the difference in water temperature between the surface layer and the deeper layers gets greater.

Figure 5 shows the annual temperature changes in the three test sites. During February and March the water temperatures are quite stable. A rather rapid rise begins in April. During June and July the rise is the fastest. In August and September, it is again stable. This agrees with the curve of average annual surface water temperature changes in the Dalian-Chengshanjiao area from 1928 to 1937[1].

Figure 5: Annual changes in surface layer temperature at the three test sites



He Chongben [6378 1504 2609] et al. consider that during periods of rising temperature there will also be large daily and weekly changes in surface layer water temperature. Due to this it can be seen that from March to May, the day changes in the surface layer water temperature gradually increase. It can be said that this is a common characteristic of the surface layer water temperature variation of the entire Huanghai Sea and Bohai Sea areas. Thus, from March to May, the distortion in the sea surface isotherms from ship measurements also gradually increases.

Ship measurements were carried out once per month. The time required for each varied from 1 to 2 weeks. In order to lessen the effects of day to day water temperature variation at the time the isotherms were being drawn, for all data a linear extrapolation method was used to convert the ship measured data of the day when it was most plentiful to the rest of the month. Isotherms were

drawn by computer. The final pass on the image was handled by convergence by comparison with the AVHRR temperature map.

AVHRR [1] [Advance Very High Resolution Radiometer] remote sensed data

The AVHRR digital imagery data differentiation was obtained from the TIROS-N (1979) and NOAA-6 (1980) solar synchronous, near polar orbit satellites. TIROS-N passed over the Huanghai Sea at approximately 0100 hours and 1300 hours Beijing time; NOAA-6 passed over at approximately 0700 hours and 1900 hours. Orbital altitude was 800 km. For details, see Reference [8].

AVHRR is a scanning imagery radiometer consisting of 4 spectral regions (5 spectral regions starting with NOAA-7). Its resolving power is 1.1 km by 1.1 km (beneath the satellite). Each region's wavelength range is as follows (units:  $\mu\text{m}$ ):

	TIROS-N	NOAA-6
spectral region 1	0.55 - 0.9	0.58 - 0.68
spectral region 2	0.725 - 1.1	0.725 - 1.1
spectral region 3	3.55 - 3.93	3.55 - 3.93
spectral region 4	10.5 - 11.5	10.5 - 11.5

Spectral regions 1 and 2 are set to detect the near infrared wavelengths. In measurements of sunlight reflectance, at 100 percent indication, the precision is about 0.1 percent. The calibration of the sensor was performed experimentally before launching. The strongest reflection from the cloud top could amount to more than 40 percent. But with no clouds, the reflectance from the sea surface is just about 1 to 2 percent. Therefore, measurement results from spectral regions 1 and 2 can be used to identify "cloudiness" (limited to daytime). Spectral regions 3 and 4 are set in the far infrared region, mostly in the vicinity of the atmospheric window. The work of a number of experiments (2-4,6,7) clearly indicates that if spectral regions 3 and 4 are used in combination, one can take advantage of the difference in the water vapor transmissivity of the two spectral regions and can just about eliminate the influence of atmospheric water vapor making for more precise determinations of sea surface temperatures.

Calibration of the sensor of spectral regions 3 and 4 was carried out real time on the satellite. Before each scan of the earth's surface, the sensor first samples the darkness of space (radiation temperature is absolute zero) and the zero point of the sensor is set. At the conclusion of each scan of the earth's surface, the sensor sweeps an on-board black body target of an insulated and constant temperature (288°K) and from this, the slope of the sensor is set (5). According to this, the results of a scan of the earth's surface (radiation energy) can be converted to radiation temperature (the emissivity of the sea surface in the wavelengths 10 to 12  $\mu\text{m}$  is approximately 0.99, so it can be considered as an absolute black body). Results of all four spectral region measurements (including temperature calibration data) were digitized as 10 bit (1024 step) recordings and were passed through HRPT(5)<sup>2</sup>

2. High Resolution Picture Transmission, mid-frequency 1698.0 MHz

to the ground receiving station. The data used in this work was all provided by the U.S. National Climatic Center, World Weather Building, Washington, D.C., on GAC digital imaging magnetic tape. Geographic location corrections of images were performed according to the daily satellite orbit parameters provided by the U.S. Naval Space Surveillance System. Corrected precision was to approximately 1,000 meters.

When using spectral regions 3 and 4 to measure sea surface temperatures, the sensor noise distortion to temperature was  $0.12^{\circ} \text{K}$ (5). Among important errors involved with measuring sea surface temperatures are: 1) those caused by varying contents of atmospheric water vapor, and 2) clouds of small area (thus, difficult to identify). For the former, one can take advantage of the combination of spectral regions 3 and 4 to partially eliminate this problem. Regarding the latter problem, there is presently no effective solution. As for sea surfaces with cloud cover, due to sea surface information being entirely drowned out, it can only be abandoned.

We studied the total picture of the Huanghai Sea and the Bohai Sea areas with TIROS-N from March to May, 1979, and with NOAA-6 from March to May, 1980. Besides the fundamental differences in the calibration parameters of the original pictures by which we transformed the sun's reflectance (spectral regions 1 and 2) and sea surface temperature pictures (spectral regions 3 and 4), while carrying out geometrical corrections of geographical position, the following important matters were also dealt with.

Utilizing the fact that clouds have high reflectance and low radiation temperature characteristics, by using images from spectral regions 2 and 4, we categorized the differences between sea surfaces with and without cloud cover. Only sea surfaces in the absence of cloud cover can give correct results by remote sensing. Using known transit angles of the sea coast to make better geometric corrections of images, while at the same time by means of the land in the image and an outline of the islands, we expanded its dynamic range when dealing with individual cloudless ocean surfaces. Regarding changes to stronger and pseudo-multicolor imaging of cloudless ocean areas, we finally achieved the use of different colors to indicate different temperatures on a sea surface temperature map; the common boundary of two colors is an isotherm. According to isotherm diagrams drawn from ship measured data using image processing technology, we carried out repetitive comparisons on the AVHRR-generated sea surface temperature maps to simultaneously demarcate lines of transit angles.

What needs to be made clear is that due to the strong noise interference in the spectral region 3 image contained in the GAC image (possibly generated while stored on the satellite or during transmission) there was therefore no way to use the method of combining spectral regions 3 and 4 to eliminate atmospheric effects. Even if the images we show here haven't undergone all atmospheric corrections, it can be said that they are the original images of AVHRR (speaking directly of temperature surveys). This can also remove from the results whatever doubt that may be due to artificial "processing" of the images.

## Analysis of Results and Discussion

Plates IA and IB show the differences between the AVHRR spectral region 4 multicolor temperature images from TIROS-N on 16 March 1979 and from NOAA-6 on 17 March 1980. Sea surface temperature can be read from the colors in the plate by comparison with the multicolored reference chart below the plate. The common boundary between two dissimilar colors are the sea surface isotherms. The black curves in the diagram are the ship measured isotherms from the middle 10 days of March of the same year. The temperature value ( $^{\circ}\text{C}$ ) can be seen from the digital temperature indication on the curve. The agreement between the AVHRR sea surface temperature map and the ship measured isotherms is very good (except near Korea, because the ship measured data just covered to  $124.5^{\circ}\text{E}$ ). Note especially in Plate I: in IA, the difference between the AVHRR temperature values and ship measured values is about  $0.5^{\circ}\text{C}$ . This could be the best sea surface temperature results obtained by satellite telemetry(3). Plate IB similarly shows the best agreement in appearance between AVHRR isotherms and ship measured isotherms. But, in terms of the number value of the temperature, the two have a comparatively large discrepancy of about  $1.5^{\circ}\text{C}$ . This is because NOAA-6 and TIROS-N are not the same. At about 7 o'clock in the morning, Beijing time, as it flies over the Huanghai Sea, there may be fog on the sea surface (its temperature may be lower than the water temperature by about  $1^{\circ}\text{C}$ ). Upon detailed examination of the image one gets from spectral regions 1 and 2, it is discovered that there is an overall slight increase in sea surface reflectance. This can be from the reflectance of the mist over the entire ocean area.

In the successive years of 1979 and 1980, the month of March portion of the AVHRR temperature map and ship measured results are in very good agreement; this is not coincidental. This indicates that these two sets of reflectance corrected sea surface temperatures represent the actual situation. Attention must be paid to the stable water temperature in March in the Huanghai Sea and the Bohai Sea; thus, the temporary surface temperature variation due to daily changes, weekly changes, and the mixing due to storms is least during this period. The previously discussed results, on one hand, indicate that during this time period ship measured isotherms are all reliable; on the other hand, they also prove that AVHRR sea surface temperature images are correct.

The situation in April and May is not the same. Figure 6 shows a comparison of the isotherms drawn from the 16 April 1980 AVHRR temperature images and the isotherms from ship measurements during the middle 10 days of April (indicated by the dotted line). Figure 7 shows a comparison of the isotherms drawn from the 22 May 1979 AVHRR temperature images and the isotherms from ship measurements during the middle 10 days of May (dotted line).

As Figure 6 shows, although there are large differences in the two groups of isotherms, the basic characteristics are the same. Figure 7 shows the two groups to be totally dissimilar. Regarding satellite remote sensing, there were no basic differences in April, May, and March. But, the situation with the ship measurements was not the same. From April on, ship measured isotherms suffered more and more distortion until, in May, the ship measured isotherms are already totally unable to reflect the actual temperature pattern.

The above discussed results make clear that February and March (probably August and September as well), are periods of relatively stable surface layer water temperatures. During these times, ship measured sea surface isotherms are reliable. At other periods during the year, ship measured sea surface isotherms are subject to varying degrees of distortion and at critical times can totally lose their reference values. This brings about a problem: in shallow water areas, how does one make exact determinations of sea surface temperatures? Simply relying on satellite remote sensing also has definite problems. Except in unusually good weather, atmospheric corrections are necessary. For even better corrections, one type of feasible method is satellite remote sensing technology in combination with actual measurements at specific sites. In the ocean region in which we are interested, buoys were arranged in certain specific areas and we can also use a few measurement ships to carry out surveys and take advantage of these actual measurement values to carry out atmospheric corrections. One can then proceed with satellite remote sensing results to find the sea surface temperature distribution of these ocean areas.

The above discussion has been confined to sea surface temperatures. Sub-surface temperatures are also a similar, current problem, but, at present, we are not yet able to apply remote sensing to sub-surface sea temperature surveys. There is still a need for further research and inquiry.

Figure 6. Comparison of ship measured isotherms (dotted line) and the isotherms drawn from AVHRR temperature images of 16 April 1980 (solid line).

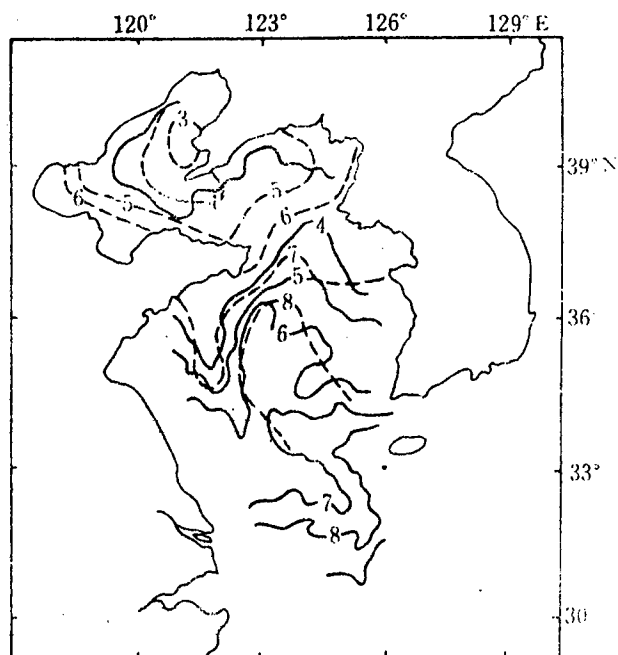
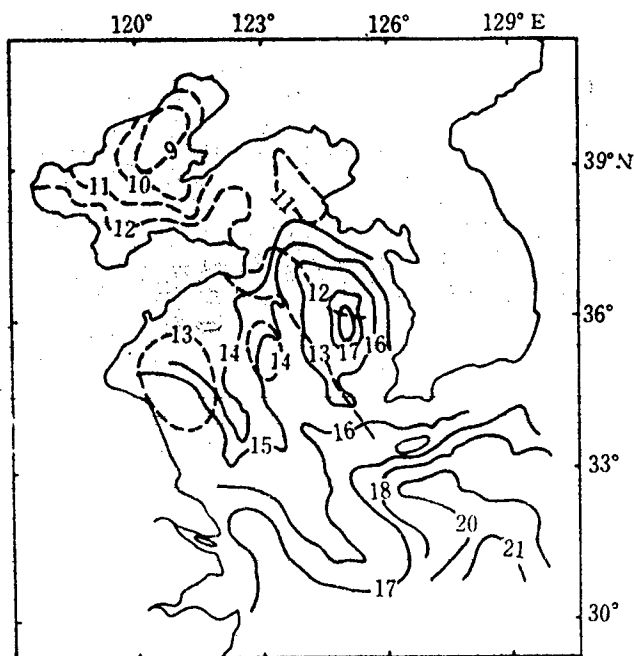

Figure 7. Comparison of ship measured isotherms (dotted line) and the isotherms drawn from AVHRR temperature images of 22 May 1979 (solid line).

## REFERENCES

1. He Chongben and Ren Yunwu, [0117 0336 2976] 1959. Investigation of a few shallow water problems. *Oceanologia et Limnologia Sinica* 2(1): 1-10.
2. Anding, D. and R. Kauth, 1970. Estimation of sea surface temperature from space. *REMOTE SENS. ENVIRON.* 1: 217-220.
3. Bernstein, R.L., 1982. Sea surface temperature estimation using the NOAA-6 satellite Advanced Very High Resolution Radiometer. *J. GEOPHYS. RES.* 87(C12): 9455-9465.
4. Deschamps, P.Y. and T. Phulphim, 1980. Atmospheric correction of infrared measurements of sea surface temperature using channels at 3.7, 11, and 12  $\mu\text{m}$ . *BOUNDARY LAYER METEOROL.* 18: 131-143.
5. Lauritson, L. and G.J. Nelson, 1979. Data Extraction and Calibration of TIROS-N/NOAA radiometers, NOAA Tech. Memo. NESS 107, U.S. Dep. of Commerce, Washington, D.C., pp 40-46.
6. McClain, E.P., 1981. Multiple atmospheric-window techniques for satellite sea surface temperature. In *Oceanography From Space* (edited by J.L.R. Gower Plenum), New York, pp 73-85.
7. Prabhakara, C., G. Dalu and V.G. Kundu, 1974. Estimation of sea surface temperature from remote sensing in the 11-13  $\mu\text{m}$  window. *J. GEOPHYS. RES.* 79: 5039-5044.
8. Schwalb, A., 1978. The TIROS-N/NOAA A-G Satellite Series. NOAA Tech. Memo. NESS 95, U.S. Dep. of Commerce, Washington, D.C., pp 1-20.

13226/8918  
CSO: 4008/1070

PHYSICAL SCIENCES

IMPROVEMENTS AND TESTS ON HT-1 SEA-SURFACE TEMPERATURE-HUMIDITY-WIND GRADIENT BUOY

Beijing NANHAI HAIYANG KEXUE JIKAN [NANHAI STUDIA MARINA SINICA] in Chinese No 4, May 83 pp 175-184

[Article by Zhang Qingrong [1728 1987 2837], Wang Dingxiang [3769 7844 4382], Wu Weihua [0702 0251 5478], Wang Guanyang [3769 7070 7402], Lin Xigui [2651 6932 6311], and Cai Qinbing [5591 6024 3521], South China Sea Institute of Oceanology, Chinese Academy of Sciences: "The Improvement and Experiment of Sea-Surface Temperature-Humidity-Wind Gradient Buoy Type HT-1"<sup>1</sup>]

[Text] English Abstract: This instrument is an improvement of Sea-Surface Temperature-Humidity-Wind Gradient Buoy Type HT-1 made by Shandong College of Oceanology. In this paper, the principle and the structure as well as the improved parts of the instrument are described. The results of trial measurements in sea have been roughly analyzed, thereby the accuracy and the stability of the instrument have been confirmed. A design has been made as to the existing problems for further improvement.

The sea-air interface movement, heat and water-vapor exchange are important parts of research on sea-air interaction. Observation of temperature, humidity, and wind gradient near the sea surface is an important method of determining the volume of these exchanges. Such observation of temperature, humidity, and wind gradient near the sea surface are generally carried out by a specialized buoy<sup>1</sup>.

Using the type HT-1 sea surface temperature-humidity-wind gradient meter developed by the Shandong College of Oceanology as a base, we developed an improved sea surface temperature-humidity-wind gradient meter. The instrument is divided into three parts: wind measurement, temperature measurement, and the buoy. The buoy can float about 120 meters from the ship and make

---

<sup>1</sup>Comrades Deng Hanzeng [6772 3352 1073] and Liao Xingshi [1675 5281 2160] of this institute participated in some work on the buoy. In the research and development process, Professor Liu Lianji [0491 6647 0679], of the Shandong College of Oceanology, gave enthusiastic direction, Comrade Deng Jiuzi [6772 0046 0098] of our institute provided valuable opinions and assistance, the photographs in this paper were taken by Comrade Huang Huawen [7806 5478 2429] and here we thank them! This paper was written by Zhang Qingrong.

observations at water depths >10 below the sea surface, it can observe 5 temperature, humidity and wind factors at any height within a range of 6.5 meters above the sea surface and the sea water surface temperature.

The important improvements are: the wind measurement transducer, the wind measurement stable voltage power supply, temperature and humidity measurement constant-current source, temperature and humidity measurement conversion device, and the temperature measurement small motor device.

Laboratory appraisal and use in test observation at sea prove that the measurement range and precision are as in Table 1.

Table 1 Range and Precision

Category		
Item	Range	Precision
Wind velocity	0.5-20.0 m/sec	±0.1 m/sec
Wet/dry hygrometer	10.0-32.0°C	≤±0.05°C

## I. Principles and Structure of the Instrument

### A. Wind velocity part

1. Structure and wind measurement principle of the wind velocity transducer: uses a three-cup wind velocity transducer (Figure 1), this transducer uses a bearing as the spin axis, and thus has the advantage of durability. The factory-set starting wind velocity is less than 0.7 m/sec, and after verification by the Central Meteorological Bureau, the actual starting wind velocity was about 0.5 m/sec. The factory-set turning parameter is 0.952 turns/m·sec, the appraisal results are given in Table 2. It can be seen that there is a <0.01 error between these values and the standard values. To eliminate the impact of these errors on wind measurement precision, each wind velocity transducer uses its own verification curve.

Wind velocity measurement is carried out according to the principle that the number of wind cup rotations forms a linear relationship with wind velocity. A photoelectric emitter follower circuit is installed in the wind velocity transducer (Figure 2). On each wind cup bearing there is a light screen with 9 slits in it. The light screen turns as the wind cups rotation and each time the light of a small bulb shines through the slits on a photoelectric diode, the emitter-follower produces a 5-6V pulse signal which is relayed through an electric cable to the wind velocity indicator count and is displayed.

2. Wind velocity display principle: The pulse signal produced by the wind velocity transducer installed on the small buoy is sent to the shipboard wind velocity indicator count display through a 200 meter cable. (Figure 2)

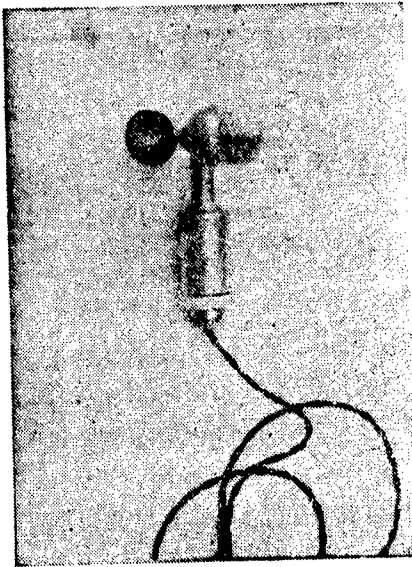

Figure 1 Three cup Transducer

The pulse signal is first sent to a shaping amplification circuit to make the leading and following edges and the amplitude of the pulse signal satisfy the demands of the MOS circuit, so that the frequency division, counting, decoding and display components of the MOS circuit operate normally.

The shaping amplified signal then goes through the controlled gates (the gates are made up of JAG-4HC), switches, timing circuits, and control bistable circuits, to 10 or 100 frequency input terminals, and finally enters the three place-counter and is displayed<sup>2</sup>.

In the timing circuits, we used a parallel-type 4KC crystal oscillating circuit, which is comparatively stable.

Table 2 Wind Transducer Parameters

Item	Number 2	3	4	8	10
Starting wind velocity (m/sec)	0.58	0.71	0.58	--	0.59
Rotation parameter	0.957	0.960	0.958	0.945	0.943

<sup>2</sup>Shandong College of Oceanology, Ocean Department, Temperature-Humidity-Wind Gradient Meter Development Group, 1977, HT-1 XING HAIMIAN WEN, SHI, FENG YANGJI JI QI SHIYAN [HT-1 type Sea Surface Temperature-Humidity-Wind Prototype and its Tests] HAIYANG YIQI, No 3, pp 18-34.

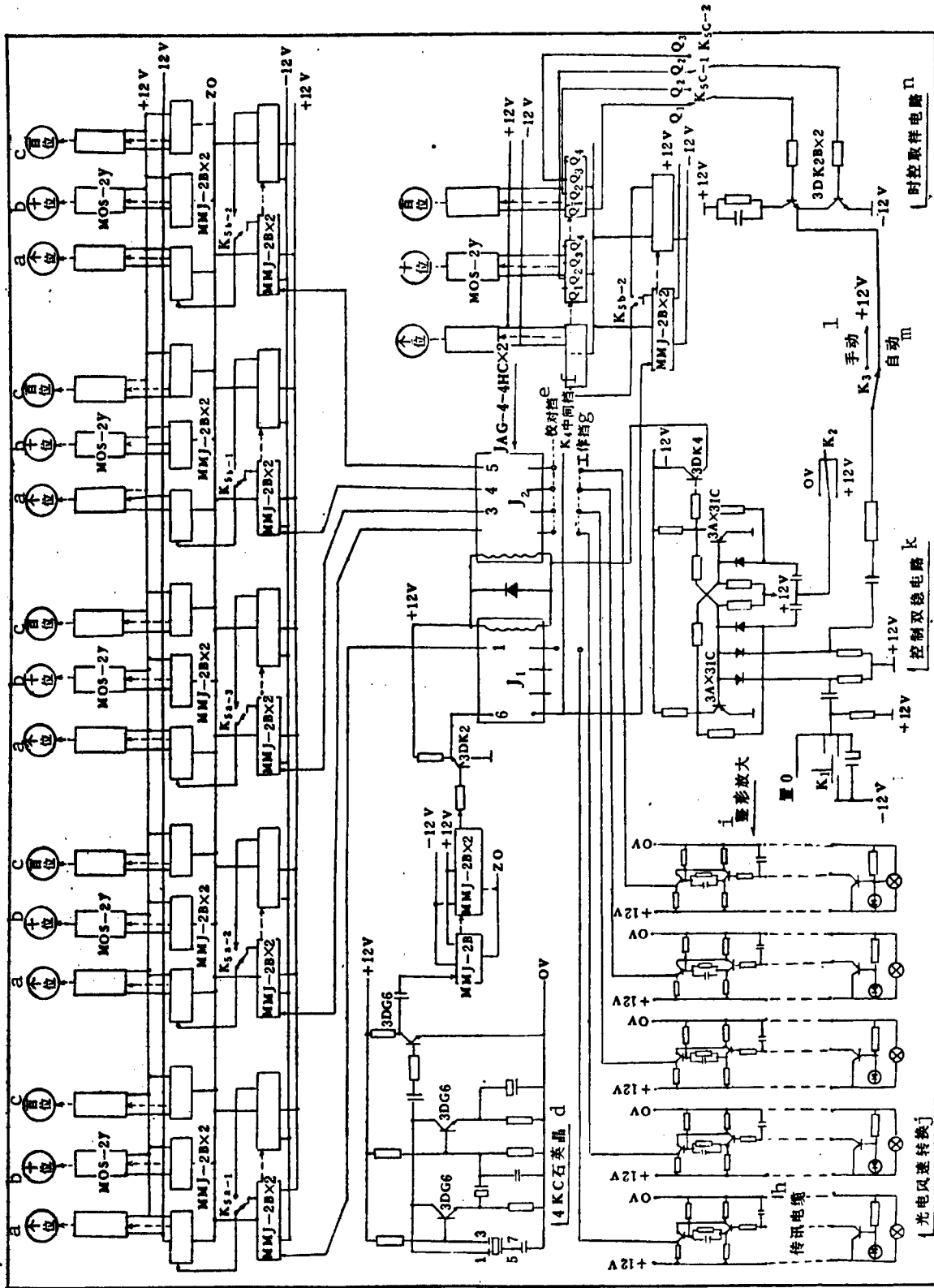

Figure 2 Diagram of Wind Measurement Circuitry

- Key:
- a. Units place
  - b. Decimal place
  - c. Hundred's place
  - d. Quartz crystal
  - e. Verifier shield
  - f. K4 intermediate shield
  - g. Work shield
  - h. Transmission cable
  - i. Shaping amplification
  - j. Photoelectric wind velocity conversion
  - k. Bistable control circuit
  - l. Manual
  - m. Automatic
  - n. Time control sampling circuit

In addition, what the wind velocity display required was +12V and -12V DC power supply, so we changed to a stable voltage power supply made up WB724 integrated blocks (Figure 3).

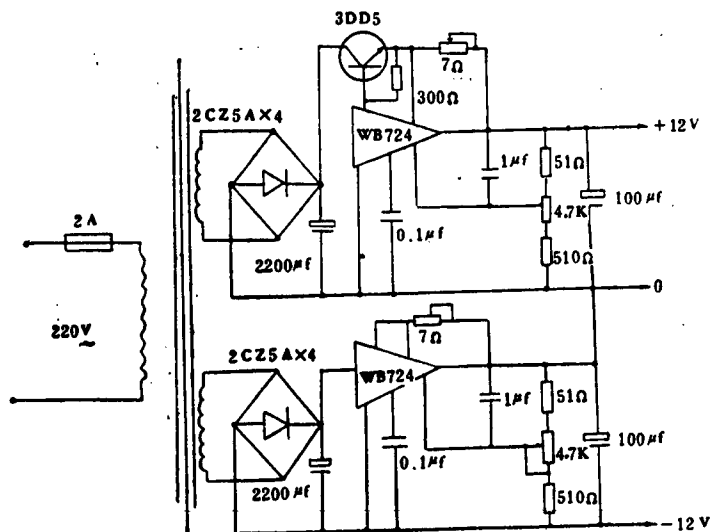

Figure 3 Diagram of Wind Measuring Power Supply Principle

This instrument could measure an average wind velocity of 12 seconds, and within this time frame, the number of pulse signals read out was about the same as the actual wind velocity, thus a wind velocity value could be roughly read directly, and there were average wind velocity values of 60 seconds and 600 seconds. Of them, the 12-second signal was taken from the second and third places of the three place time count. When the second place's MMJ-2 (8421 code) was 2 and the third-place MMJ-2 was 1,  $CM_2$  and  $CM_1$  simultaneously changed from low potential to high potential. These two high potentials simultaneously provided the time control sampling circuit so that the time control circuit had a negative jump output used to trigger the control bistable flip-flop and automatically close gates 1-6.

By the same principles, the 60 second and 600 second signals are taken from the third place  $CM_2$  and  $CM_3$ .

Their switches are:

- $K_1$ -"set zero" button switch;
- $K_2$ -"start-stop" button switch;
- $K_3$ -"manual-automatic" switch;
- $K_4$ -"operate-compare" switch;
- $K_5$ -"time control select" switch;
- $K_6$ -"power supply" switch

It should be pointed out that When  $K_3$  is set to manual, the average wind velocity of any time interval can be measured, and when set to automatic, the average wind velocity of the above three time intervals can be measured. However, before the fact the verification curve of the relationship between the average wind velocity of that time interval and frequency should be made.

## B. Temperature and Humidity Measurement Section

1. Basic principles: a bulb hygrometer measures dryness and humidity by means of the vent humidity-meter principle. Measurements are carried out using the general purpose three-wire compensation and unbalanced bridge circuit method. See Figure 4 for the circuitry. The constant current source was rebuilt with WB724 integrated blocks. The output current of point A is 2.05MA, the voltage across AB is 5.63V. The average bridge's fixed arm  $R_7$  and  $R_8$  are  $R_{x70-0.25}$  type  $500\Omega$  precise resistors and  $R_{x70-0.25}$  type  $510\Omega$  precise resistors wound several times with manganese copper wire are used for fandang [0433 2346] resistors  $R_9-R_{19}$  to buqi [5943 7871 supplement?] the resistor values.  $R_{f1}-R_{f11}$  are platinum resistors of about  $500\Omega$  used for temperature sensing elements;  $R_{f1}-R_{f5}$  for dry bulb temperature;  $R_{f6}-R_{f10}$  for wet bulb temperature;  $R_{f11}$  for seawater surface temperature. The unbalanced bridge is made up of fixed arm resistors  $R_7$  and  $R_8$ , fandang resistors  $R_9-R_{19}$ , and temperature sensing resistors  $R_{f1}-R_{f11}$ . As the temperature changes, the reading of the potential difference produced at the two points C and D on the platinum resistor is read by an XWX-104 electronic potential difference meter.

The platinum resistor is a glass rod 6 cm long and 0.5 cm thick which is wound with 0.025 mm platinum wire. Its temperature characteristic relationship equation is  $R_f=R_0(1+\alpha t)$ , in which  $R_0$  is the resistance of the platinum resistor at  $0^\circ\text{C}$ ,  $\alpha$  is the resistor's temperature coefficient, which is 3.94 per thousand, thus it can be seen that  $R_f$  forms a linear relationship with temperature  $t$ . In transistor  $R_t$ , as the temperature changes, the bridge becomes unbalanced, and the output voltage  $\Delta V$  also changes with temperature  $t$ . Calculations and actual tests prove that when the temperature changes  $1^\circ\text{C}$ , there is a 0.98 mV changes in the voltage of the platinum resistor's unbalanced bridge.

The stable voltage circuit of the vent small motor was changed and made up with WB724.

2. Temperature transducer support structure: Figure 5 is the temperature transducer support which basically used the form of the Shandong College of Oceanography's, whereby the platinum resistor is installed inside the twin-layered chromium casing on the bottom part of the three-way body. The wet bulb temperature gauze is wound on the platinum resistor, and the other end is placed in a water storage tube on its lower part. The upper part is the vent motor support, in the middle is the chromium tube that connects the vent motor and the three-way body. Practice proves that this support performs well in resisting radiation and heat conductivity, and through verification, the wind velocity of the small fans moved by the vent motor  $>2.1$  m/sec.

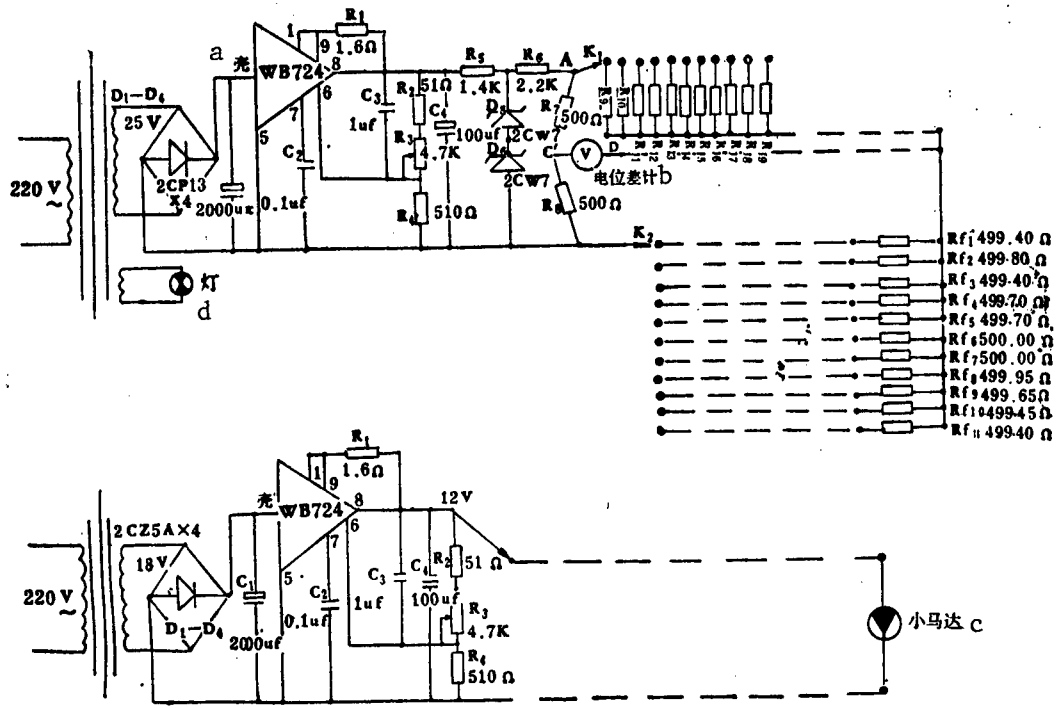

Figure 4 Diagram of Temperature Measurement Part Principles

- Key:
- a. light
  - b. potential difference meter
  - c. small motor
  - d. lamp

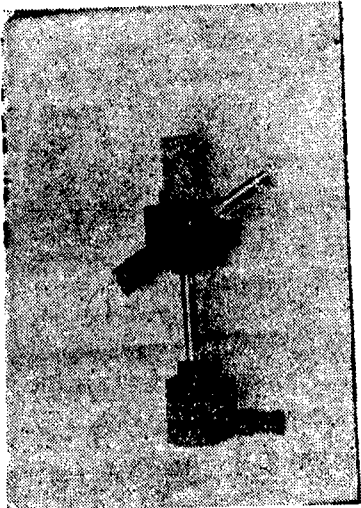

Figure 5 Temperature Transducer Support

The seawater surface temperature transducer is installed on the buoy. Its induction part is placed about 0.5 m underwater. See Figure 6 for an illustration of its structure. The platinum resistor is installed inside the copper tube.

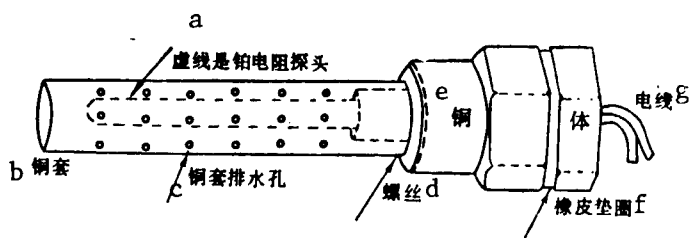

Figure 6 Seawater surface temperature transducer

Key:

- a. Dotted line is the platinum resistor probe
- b. Copper tube
- c. Copper tube water escape holes
- d. Screw threads
- e. Copper body
- f. Rubber gasket
- g. Electric cable

3. Converter box: The converter box is installed on the buoy's mast. The wires from the 11 temperature measuring platinum resistors and 5 layers of wind velocity transducers are all concentrated in the converter box and connected to the shipboard cable so that the signals can be relayed from the buoy to the various recorders on shipboard. For conversion of the 11 temperature measurement transducers we switched to 11 individual knife switch switchovers (Figure 4), thus reducing temperature measurement errors created by contact.

#### C. Buoy Part

The buoy support upper ellipse has a long axis of 1.4 m and short axis of 1.2 m, the lower ellipse has a long axis of 0.9 m and a short axis of 0.25 m, the support is 1.55 m high. The upper mast is 6.55 m long and the lower mast is 5.8 m long, three heavy blocks weighing 45 kg are placed at the lower end of the lower mast, the 10 cross-bars on which are installed the temperature, humidity, and wind transducers are placed at heights of 0.5, 1.0, 2.0, 4.0, and 6.0 meters above the water. Between the cross-bars are fixed adjustable kahuan [0595 3883] and the cross-bar height can be adjusted at will. Total weight is 400 kg but the buoyancy of the small floats inside the buoy is 485 kg, thus the excess buoyance is 85 kg.

## II. Preliminary Analysis of the Tests and the Results

Figure 7 is a photograph of a small buoy in operation at sea. This is the first time that such trial measurements have been taken in the South Sea in China and we have not seen reports of them from abroad. Some of the results of trial measurement of temperature, humidity, and wind from November, 1979, are graphed in Figures 8, 9, and 10. From the graphs we know:

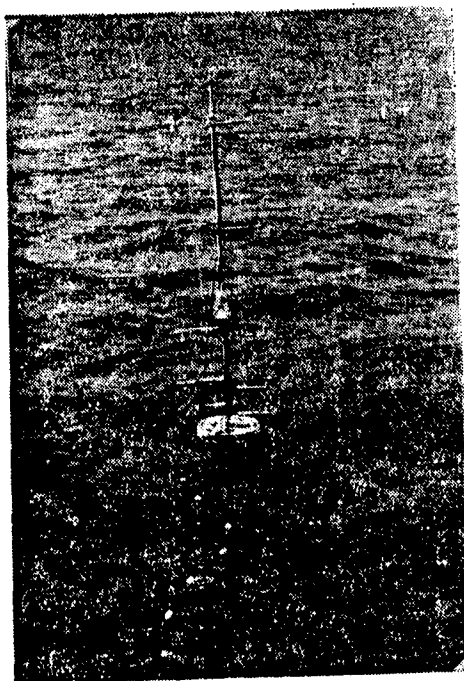

Figure 7 Small Buoy in Operation at Sea

1. The dry and wet bulb temperature outline contours are very similar. Above a height of 0.5 meters there is a turning point of a lower temperature, but there were some exceptions in the wet bulb temperature outline for the 14th and the 15th which was created by the influence of cold air.
2. From the 4 graphs of dry and wet bulb temperature outlines it can be seen that at the cold air transition point, after the cold air passes, and the weather becomes warm again and the cold air arrives, there are slight differences in the outline contour, which means that the outline contour has been influenced by weather conditions.
3. The dry and wet bulb temperature outline contours are very different from the wind velocity outline contours.
4. Due to the influence of daily changes, i.e., the influence of changes in intensity of the turbulent flow in the air layer near the water's surface within a single day, after noon, the intensity of the turbulence is great and becomes smaller by degrees.

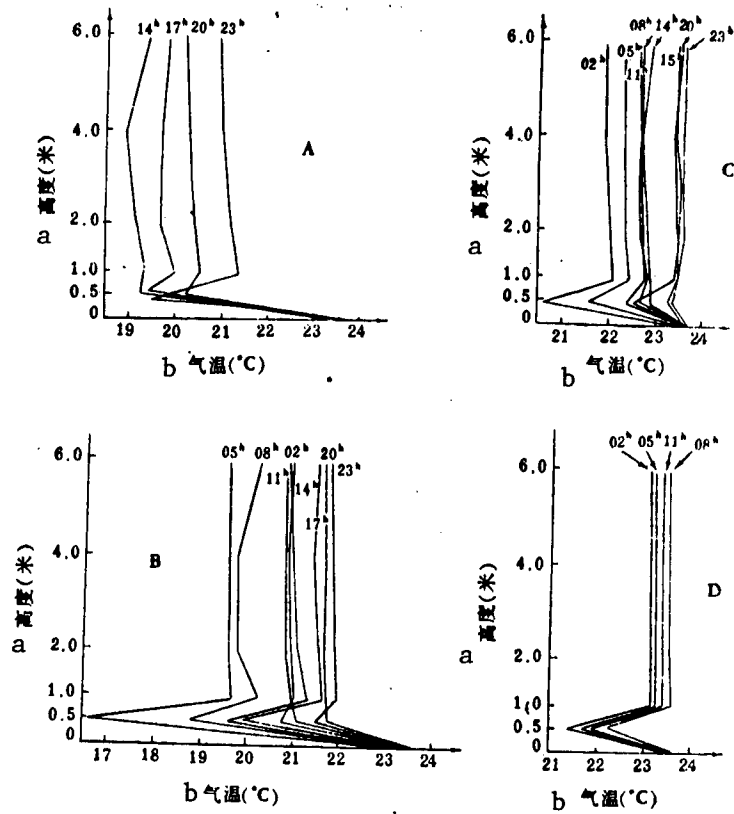

Figure 8 Outlines of Air Temperature Near the Water Surface

- A. Cold air process on the 14th
- B. After the cold air process
- C. Weather returns to warm on the 16th
- D. Cold air suddenly arrives on the 17th

Key:

- a. Height (m)
- b. Air temperature (°C)

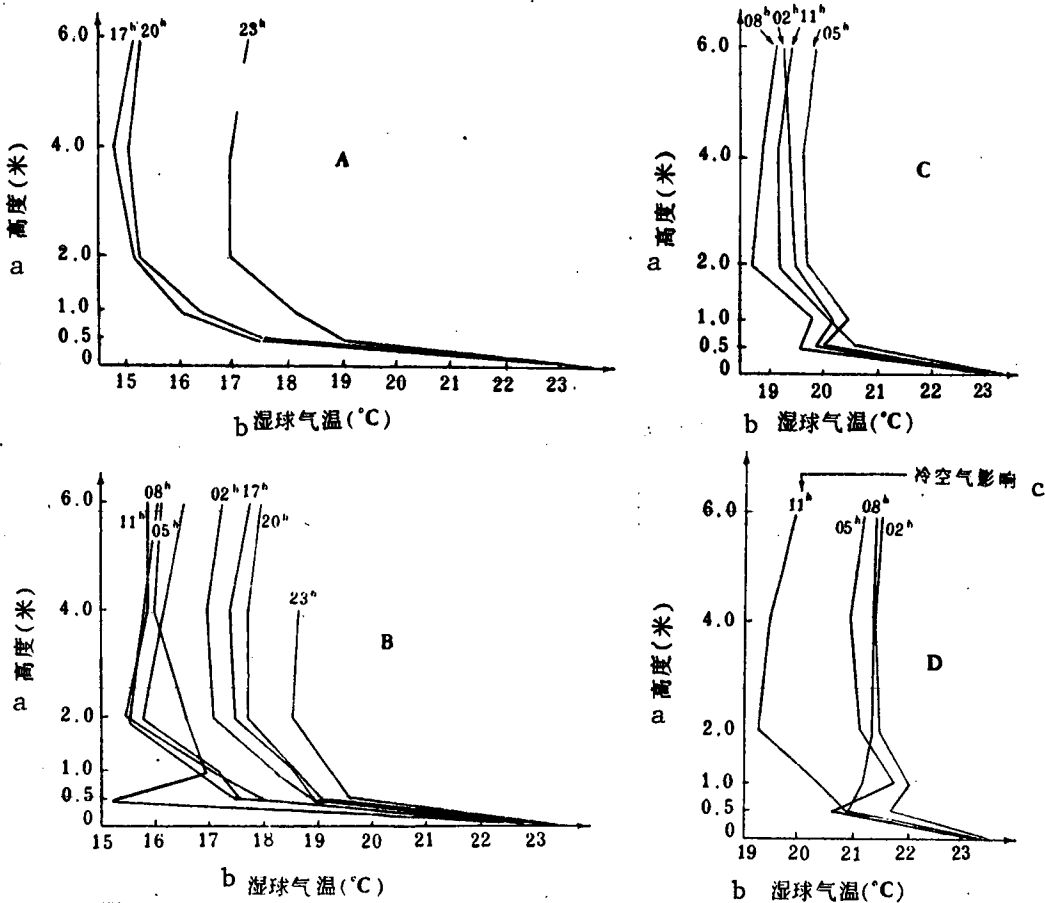

Figure 9 Outlines of Wet Bulb Temperature of Air Near the Water Surface

- A. Cold air process on the 14th
- B. After the cold air process
- C. Weather returns to warm on the 16th
- D. Cold air suddenly arrives on the 17th

Key:

- a. Height (m)
- b. Wet bulb temperature (°C)
- c. Influence of cold air

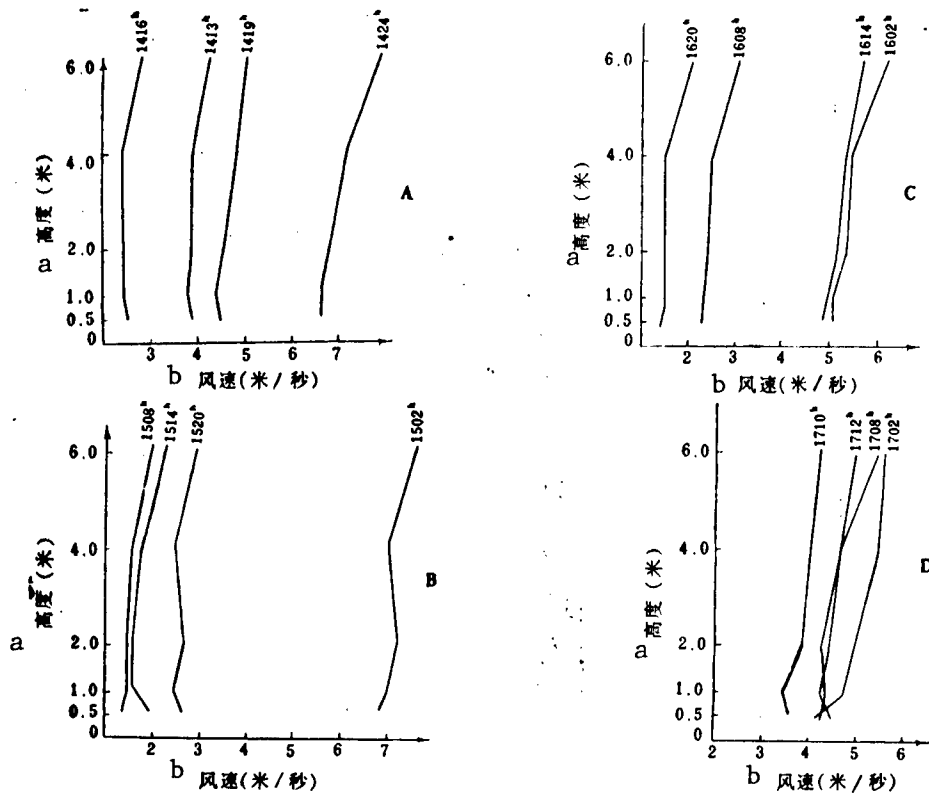

Figure 10 Graph of Wind Velocity Outline Near the Water Surface

- A. Cold air process on the 14th
- B. After the cold air process
- C. Weather returns to warm on the 16th
- D. Cold air suddenly arrives on the 17th

Key:

- a. Height (m)
- b. Wind velocity (m/sec)

In summary, changes in the outlines are regular, here we can only describe them briefly in a few sentences, but to prove the reliability of the instrument detailed analytical researches will be reported in another paper.

### III. The Instrument's Precision and Its Stability

#### A. Results of Verification in the Test Laboratory

1. Wind velocity part: It has already been pointed out above that through verification in the Central Meteorological Bureau's wind tunnel, the starting wind velocity was generally about 0.5 m/sec. In addition, from the verification curve it can be seen that the average error within 1 minute was  $<0.1$  m/sec.

2. Dry, wet bulb temperature part: Verification of the dry/wet bulb temperature and sea surface temperature transducers was carried out according to the procedures for meteorological instrument verification. The results of verification are reorganized in Table 3.

Table 3 Table of Accumulated Error Statistics

Error range	$<\pm 0.00$	$<\pm 0.02$	$<\pm 0.03$	$<\pm 0.04$	$<\pm 0.05$
Percent	57%	73%	89%	97%	99%

From the table it can be seen that the 99 percent which makes up the error range  $<\pm 0.05$  and the 1 percent that make up  $\geq 0.05$  may be due to verification reading error.

#### B. Results of Contrasting Measurements at Sea

"Determination of an instrument's precision can only be obtained in the laboratory after verification according to procedural demands."<sup>3</sup> To better prove the precision of the instrument and its stability, during the trial observations we also carried out synchronous observations using the sea water surface temperature transducer of a gradient instrument and a closed-end reversible thermometer hanging on the ship's side. The sea water surface temperatures measured are plotted in Figure 11. The reversible thermometer's measurements are lacking in several time segments, so we have interrupted the dotted line. From the graphs we can see that (1) Changes in the two tend to fit very well, which means that the gradient instrument's measurements of dry and wet bulb temperature is fairly stable; (2) the water temperature measured by the closed-end reversible thermometer are mostly higher than the sea water surface temperatures measured by the gradient instrument, because the closed-end reversible thermometer was hanging on the ship's side and this was created by the influence of the ship's hull; (3) there are also several points where the differences are greater, and that is due to accidental error of the gradient instrument and errors reading the reversible thermometer.

<sup>3</sup>Haiyang Yiqi Yanjiuso Ershi Wenduzu [Oceanology Instrument Research Institute, No 2 Laboratory, Temperature Group], 1978, REMIN DIANZU WENDUJI YU DIANDAO WENDUBIAO BUZE WENTIDE TANTAO [DISCUSSION OF THE PROBLEM OF COMPARATIVE READINGS OF THERMO-SENSITIVE RESISTOR TEMPERATURE METERS AND REVERSING THERMOMETERS], Haiyang Yiqi No 3, pp 37-43.

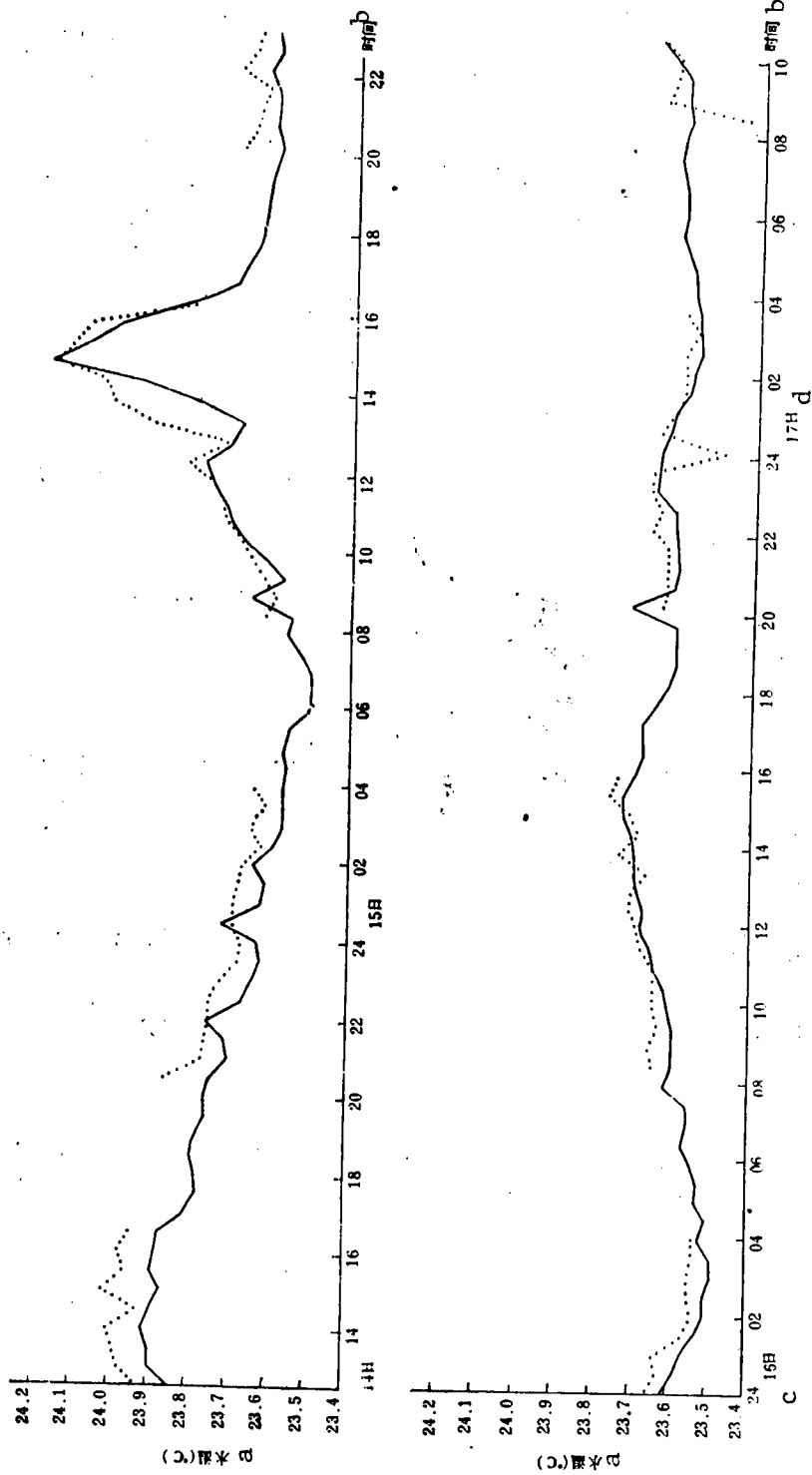

Figure 11 Comparative Curves of Seawater Surface Temperature Measured by Gradient Instrument and Closed-end Reversible Thermometer

----- Gradient instrument water temperature  
 ..... Reversible thermometer water temperature

Key: a. Water temperature (°C)      c. 15th  
 b. Time                                      d. 17th

The precision of the reversible thermometer's temperature measurement was: the random limiting error was  $\pm 0.05^{\circ}\text{C}$ <sup>4</sup>. Thus, combining those from the lab and at sea we feel that a gradient instrument measured dry/wet bulb temperature and sea water surface temperature error of  $\pm 0.05^{\circ}\text{C}$  is completely believable.

What must be said is: since the laboratory verification temperature measurement system was carried out during the summertime, a water trough temperature of  $0^{\circ}\text{C}$ - $10^{\circ}\text{C}$  was difficult to control, therefore we did not obtain verification results within this range, and these will have to be carried out after the water trough temperature control has been improved so that the expanded dry/wet bulb temperature and sea water surface temperature measurement range can be  $0^{\circ}\text{C}$ - $35^{\circ}\text{C}$ .

#### IV. Views on Current Problems and Further Improvements

1) Synchronous observation of measuring dry and wet bulb temperatures has not yet been realized, i.e., the time required for 11 temperature measurement transducers is about 5 minutes, and if the difference between the lowest temperature at 5:00 in the morning to the highest temperature at 14:00 in the afternoon is  $10^{\circ}\text{C}$ , i.e., a change of about  $1^{\circ}\text{C}$  each hour, then each minute it changes  $0.016^{\circ}\text{C}$ , then in 5 minutes it changes  $0.08^{\circ}\text{C}$ , and that change is very observable, therefore synchronous observations must be improved, i.e., complete the conversion of 11 temperature measurement transducers within a few minutes.

2) We should improve digitization of temperature measurement true readings and digital print out, i.e., the numbers printed out are the dry and wet bulb temperatures and the sea water surface temperature, and not use verification curves any longer.

3) On the basis of the current 3 window time intervals, i.e., 12, 60 and 600 seconds, to the wind measurement section should be added to the 600 second time interval range an average wind velocity readout every 2 minutes so that in within 600 seconds 5 such average wind velocities would be output.

4. Other aspects still require improvement.

---

<sup>4</sup>Qin Siren [4440 0843 0088], 1978, BIDUAN DIANDAO WENDUBIAODE "JINGDU" DAODI SHI DUOSHAO? [JUST WHAT IS THE "PRECISION" OF THE CLOSED-END REVERSIBLE THERMOMETER?] Haiyang Yiqi, No 3.

(Paper received 26 April 1980)

#### REFERENCE

1. Bortokovskii, R.S., 1974, PROTSSESSY PERENOSA BVLIZI POVERKHNOSTI RAZDELA OKEAN-ATMOSFERA [PROCESSES OF TRANSFERRING OCEAN-ATMOSPHERE NEAR THE SURFACE], Gidrometeoizdat, pp 8-10.

8226/7358

CSO: 4008/1066

## PHYSICAL SCIENCES

### DEEP-WATER MOORED BUOY SYSTEM TESTED

Beijing NANHAI HAIYANG KEXUE JIKAN [NANHAI STUDIA MARINA SINICA] in Chinese  
No 4, May 83 pp 185-189

[Article by Chen Fupei [7115 4395 1014], South China Sea Institute of Oceanology, Chinese Academy of Sciences: "The Test for a Deep-water Moored Buoy System," Paper received on 5 February 1980. This test was discussed and carried out by personnel of this institute's Hydrometeorology Research Laboratory's Sea Current Group and the R/V "Shiyan"]

[Text] English Abstract: the test for a deep-water moored buoy system was made successfully in the South China Sea by our R/V "Shiyan" from 3-8 June 1978. The buoy was deployed at 110°41'E, 15°48'N nearby the West of Zhongjian I., Xisha Islands, at a depth of about 745 meters.

The currents were measured with recording currentmeters attached to the moorings at the various layers depth of 10 m, 100 m, 200 m, and 300 m simultaneously and the rather satisfying records were obtained. On the whole, the design of the buoy system has met with requirements. It can be used above the deeper water temporarily at the normal sea-conditions, but it may be taken further tests at the bad sea-conditions.

In this paper, the structure of the buoy system and the connections of its components are described, as well as a practicable method for deployment and retrieving of the buoy system is given.

#### I. Natural Environment in the Vicinity of the Buoy Station

The buoy station is located approximately 20 nautical miles west of Zhongjiandao in the Xisha Archipelago (110°41'E; 15°48'N) at a depth of 745 meters. It was released on 3 June 1978 and recovered on 8 June, an elapsed time of 5 1/2 days.

The changes in water depth in the vicinity of the buoy station are not great, the sea bottom surface is gentle, the bottom is mostly soft mud, and the anchorage is excellent.

In the first 10 days of June, at the buoy station and its surrounding sea the prevailing winds were seasonal southwest winds, with wind speeds generally of 6-8 m/sec, with the maximum near 11 m/sec. The sea conditions were stage 3-4

with the maximum at stage 5. Wave heights were mostly above 1 m, but the maximum could reach 3.5 m. Wave direction was mostly due south, the average period being about 5 seconds, with a maximum of 7.5 seconds.

The measured sea current velocity at the buoy station's 10 meter level was generally above 1 knot, with the maximum reaching 1.8 knots. The average yuliu [0151 3177] current velocity was about 0.7 knots, flowing from SSE to NNW. The tidal current and yuliu corresponded, with the average tidal current velocity being stronger, at about 0.7 knots. However, no clear shifting was observed to have occurred at the buoy station.

## II. Buoy Station Structure

The buoy station's structure was designed on the basis of the water depth, number of current layers to measure, sea conditions and ease of operation, and was composed of the buoy itself, auxiliary equipment, main cable, the attachment linkage part, anchor, and anchor marker (See illustration).

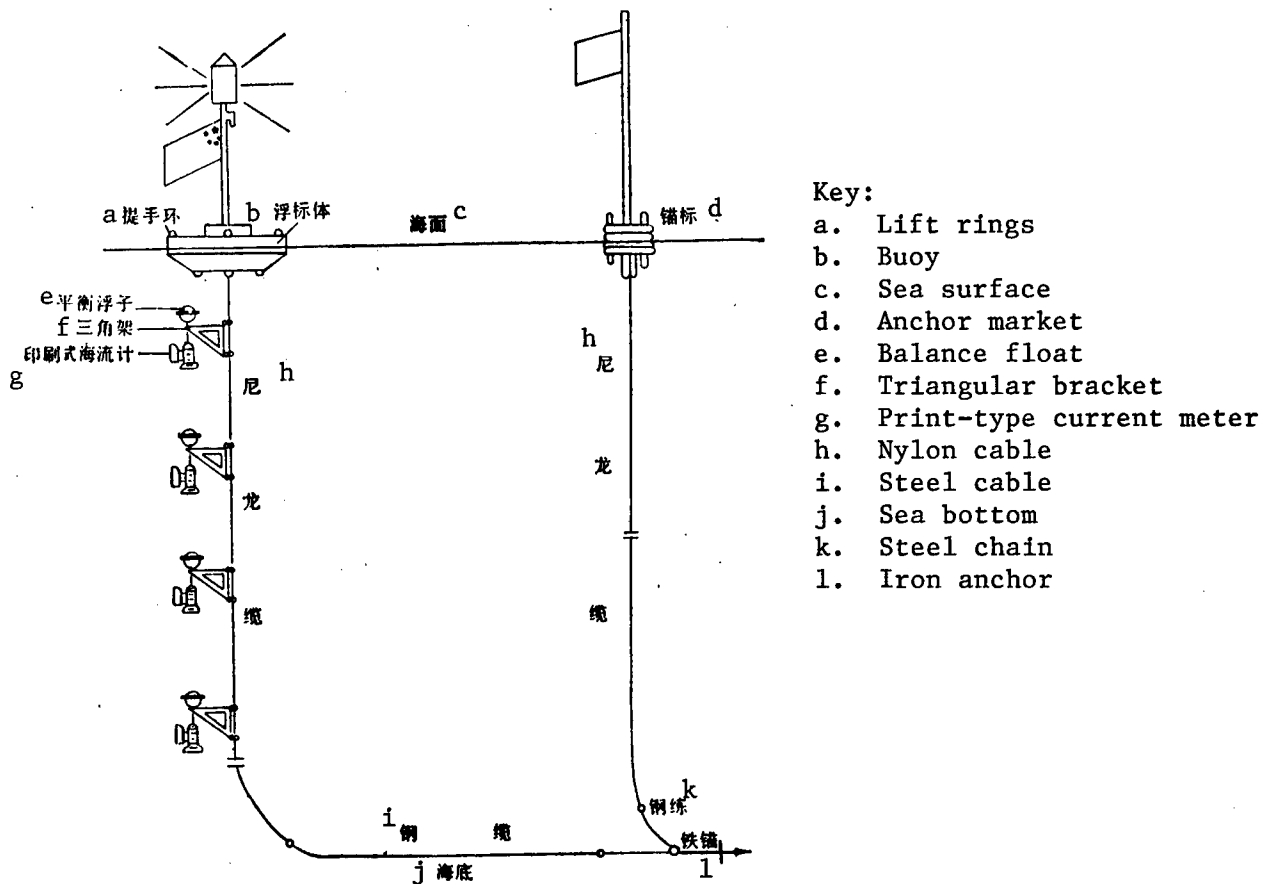

Figure 1 Diagram of Buoy Station Structure and Deployment

(1) The buoy and its auxiliary equipment: The buoy was a disk-shaped steel structure 40 cm high and 2 m in diameter, with the beacon pole it was 185 cm in height overall and at the upper end of the beacon pole hung a small Chinese flag. The auxiliary equipment included the hanging chain, float rope, and carrying cable. The hanging chain was two sections of steel chain 6 mm in diameter and 5 m long linked to the beacon pole and the buoy's lift rings; the float rope was a nylon rope 15 m long which carried a number of plastic floats, one end fastened to the lift rings, and the rest floating on the water surface; the carrying cable was a steel cable 11 mm in diameter and 12 m long one end of which was attached to the lift rings on the buoy and the other end linked to the main cable at the end of a steel chain 9 m below the buoy. The object of fixing the above mentioned auxiliary cable was to facilitate recovery hoisting.

(2) Main cable: The main cable was made by linking many sections of nylon cable, steel cable, and steel chain of 32, 11, and 12 mm diameters respectively. The nylon cable was 3 sections of 100 m, and 2 sections of 300 m in length for a total of 700 m; the steel cable had a total of 3 sections, 37, 47 and 450 m in length, respectively. The steel chain was in two sections, 9 m and 10 m in length, respectively. To keep the attachment linkage part from rubbing through the nylon cable, a 1 m section of chain was placed at the nylon cable linkage. The linkage sequence of the sections of the main cable are as illustrated. The main cable from the buoy to the anchor was a total 1,260 m.

(3) The attachment linkage part was made up of four print-type currentmeters with triangular brackets. A plastic float was suspended from one end of the triangular bracket to balance the weight of the current meter in the water.

(4) Iron anchor: The iron anchor was an ordinary iron anchor commonly used by small boats and weighed 12 kg.

(5) Anchor market: The anchor market was a wooden framework with enough floats to give it good flotation stability. On top of it were two 4 m-high rods to carry the anchor ball and a red flag. At the bottom end of the anchor market was a nylon cable 20 mm in diameter and 1,000 m long connected to a section of chain and the iron anchor. The function of the anchor market was to extend the search buoy stations, and if the buoy sank due to an accident, the anchor market could be fished out and the buoy station recovered. Naturally, under ordinary circumstances, the buoy station could also be recovered from the anchor market. Whether or not anchor markers were deployed depended on the reliability of the buoy's performance, and it was best avoided.

(6) Overall weight of the buoy system was about 912 kg (see Table 1 for details).

The water displacement of the buoy was about 1.2 tons, and with the buoyancy of the auxiliary plastic floats, the overall buoyancy could reach over 1.30 tons. Thus, the net buoyancy of the buoy station still was about 360 kg. In fact, after the buoy station's anchor was released, and the iron anchor and the 10 m of chain connected to it and the corresponding portions of the 450 m of steel cable were lying on the bottom, the net buoyancy of the buoy station should have been greater than 360 kg, and the actual draft of the buoy station was about 30 cm.

Table 1 Weight of Buoy System Components

<u>Name</u>	<u>Scale (mm)</u>	<u>Unit weight (kg)</u>	<u>Number</u>	<u>Gross weight (kg)</u>	<u>Notes</u>
Buoy	φ2000		1	358.0	
Beacon and battery			1 set	10.0	
Steel chain	φ11	0.42	552 m	213.84	
	φ12	1.8	22 m	39.6	
Steel chain	φ 6	1.0	15 m	15.0	
	φ12	0.6	26	15.6	
Retaining rings	φ20	1.2	15	18.0	
	φ22	1.5	4	6.0	
Zhuan [6567] rings	φ17	1.5	9	13.5	
Anchor			1	12.0	
Print-type current meters	HLJ1-1	30.0	4	120.0	
Triangular brackets		18.0	4	72.0	
Total weight				911.54	

The buoy was manufactured in a geometric form two-thirds smaller than the main body of the remote-sensing buoy developed by this institute. Simulation tests of the remote-sensing buoy were made by the Shanghai Jiaotong University and the Shandong College of Oceanology<sup>1</sup>, and the results of use also indicated that the buoy's stability and wave following were very good. The main cable used by the buoy was tested and found to have a breaking strength above 7 tons, and each retaining ring and link in the linkage part could bear greater pull. Facts show that the performance of each part of the buoy basically conformed to demands.

### III. Release and Recovery of Buoy Station

Before the release of the buoy station, the sections of the main cable were installed, then connected in sequence at the time of release. The measuring instruments could be attached at will to the linkage part by the retaining rings and could be separated at will from the retaining rings at both ends of the steel chain between the sections of the main cable (i.e., the method of attachment). This facilitated operations, avoided confusion, reduced as much as possible the deck area occupied, and ensured the safety of the measuring equipment and the operating personnel. Before the buoy's release and recovery all preparatory work must be done carefully.

The buoy release and recovery procedure is as follows:

(1) The research vessel should have crane equipment which can lift more than 2 tons to a height of more than 6 meters.

(2) After the research vessel reaches the target, intensive depth measurement and positioning are carried out within a 1 nautical mile range to determine that the terrain is flat and that the position is accurate. When the buoy has been released, another precise position fix is taken and the hydrometeorological factors observed.

(3) During operation, the vessel is in a drifting state (not anchored), with the bow forming an angle of  $30^{\circ}$  to  $45^{\circ}$  with the wind direction to keep from being at right angles. At the same time, during operations, the buoy's rope and the instruments should be prevented from blowing under the vessel or getting tangled in the screw, they all operate slightly on the windward side, and pay attention to constant slow speed and adjusting the direction of the ship's bow.

(4) The buoy is released by the method of linking sections in sequence and releasing them in sequence. First the buoy is hoisted to the water surface, and at the same time the 10 m layer currentmeter is placed in the water. At this time, the end of the float rope on the buoy is fastened to the ship's side so that the buoy will not get too far away. After the 100 m layer currentmeter enters the water, the float rope can be released letting the buoy float away from the research vessel, at the same time, the main cable is constantly enter the water. When instruments are being attached, some caution should be exercised. Finally, the 450 m long section of steel cable is released connecting the iron anchor and the end of the steel cable (with a section of steel chain), at the same time, the nylon cable from the anchor market is connected by a section of steel chain to the iron anchor. Then the remainder of the 450 m steel cable and the iron anchor are slowly put into the sea. Finally, the anchor marker's 1,000 m nylon rope is gradually released into the water and when 200 m remain the anchor market is hoisted to the water surface, but not allowed to float away from the vessel's side. When the last 200 m of nylon rope has been released, the anchor market is allowed to float free of the vessel. The buoy is released in this fashion. The entire process takes 3 1/2 hours.

(5) When the buoy is recovered, because the positioning is precise, it is not hard to find the buoy. After the buoy has been found, the research vessel slowly sails close to the buoy and quickly hooks it, hoists it out of the water and fastens it to the ship's side with rope, then attaches one end of a steel chain which has been made ready to the carrying cable connected to the main cable below the 10 m layer sea current meter, and ties the other end to the winch, and reels in the cable, then recovers the 10 m layer sea current meter and hoists up the buoy and places it in a suitable place on the deck. Finally, the winch is started and each section of the main cable can be recovered, and each meter removed in order until the anchor marker has moved to the ship's side and is hoisted in.

The buoy release and recovery operation is carried out on a limited area on the deck, in a special environment: the objects are large and heavy, there are many long ropes, the control tasks are well-knit, there are many operating personnel, thus it is necessary to make full preparations. Only when the on-site organization and direction are coordinated can the release and recovery tasks be completed smoothly, otherwise, accidents can easily occur.

#### IV. Conclusion

The currentmeters used by the buoy are Chinese-made HLJ1-1 print-type currentmeters, suspended at 10, 100, 200, and 300 meter layers, respectively, and which all obtained excellent measurement data. It should be pointed out that the maximum use depth for these instruments stipulated in the instructions was 250 m, but they still operated normally at 300 m, and no water leakage occurred.

The successful release and recovery of the buoy indicates that the design of this system basically achieved the anticipated goals, the buoy's performance was excellent, and it could be used in deeper sea regions for short periods. However, whether or not this system could be used for long term observations, or could withstand the impact of heavy seas, still awaits further testing. In November 1978, this system was also used again at a similar place, and the results obtained were similarly satisfying, but this time we eliminated the anchor marker, which made it simpler, and the release and recovery only took 1 1/2 hours and a little over 3 hours respectively.

Clearly, deep-water moored sea current observation buoys have some shortcomings and need further improvement so that they become simple, reliable and automated.

#### REFERENCE

1. Zhongguo Kexueyuan Nanhai Haiyang Yanjiuso Xinjishu Yanjiushi [New Science and Technology Laboratory of the Nanhai Institute of Oceanography, Chinese Academy of Sciences], 1982, "NANFU YIHAO" HAIYANG ZIDONG FUBIAO GUANCE XITONG ["NANFU 1" AUTOMATED MARINE BUOY OBSERVATION SYSTEM], Nanhai Haiyang Kexu Jikan [NANHAI STUDIA MARINA SINICA], No 4.

8226/7358  
CSO: 4008/1066

APPLIED SCIENCES

HEAVY ION ACCELERATOR BEING BUILT IN LANZHOU

HK170850 Hong Kong ZHONGGUO XINWEN SHE in Chinese 1108 GMT 15 Aug 86

[Report by Dai Yaping [2071 0068 1627]: "China Is Building Its First Large Heavy Ion Accelerator"]

[Excerpts] Lanzhou, 15 August (ZHONGGUO XINWEN SHE)--China's first large heavy ion accelerator, which is attracting the attention of both Chinese and foreign physicists, is being built in Lanzhou. The building to house the main body of the accelerator was completed before August this year. Its injector has been assembled and adjustment has begun. The main body of the accelerator is being assembled and its components are being tested one by one.

Since the 1960's, with the development of heavy ion acceleration technology, a new area in nuclear physics--the area of heavy ion physics--has been developing rapidly. Increasingly significant prospects for the application of heavy ion beams in nuclear physics, molecular physics, solid-state physics, and materials science have been observed.

This large heavy ion accelerator, which is being built at the Academy of Sciences' Institute of Modern Physics in Lanzhou, will have an energy capacity of between 5 and 100 electron-megavolts per nucleon and will be as good as similar large accelerators in France, Japan, and other countries. With this accelerator, China will become an advanced country in the field of heavy ion physics and in producing cyclotrons.

This large heavy ion accelerator, which is referred to as Project "7611," was designed and developed by Chinese scientists and technicians. It has an injector, a main body, eight experiment terminals, and a forward-backward beam transmission line. Its main accelerator is a large separated sector cyclotron with an energy constant of 450. Each of the four large magnets in the main accelerator weighs 500 tons.

The Academy of Sciences' Institute of Modern Physics is China's most important institute conducting research in heavy ion physics. After its completion, this accelerator will be able to accelerate the light and heavy ions of more than 50 elements ranging from hydrogen to xenon and will become an important tool for experimentation in heavy ion physics research and application. It is estimated that the accelerator will be completed in 1988. After its completion, the project will be opened to both Chinese and foreign scientists as a state laboratory.

APPLIED SCIENCES

USE OF HOLOGRAPHIC TECHNOLOGY DEVELOPED

HK020316 Beijing CHINA DAILY in English 2 Jul 86 p 5

[By staff reporter Yang Xiaopiong]

[Text] People may scarcely notice that a new optical technique called holography has entered their daily lives when they visit art galleries or shop in supermarkets. But actually holography is everywhere today.

A special photographic technique making use of laser beams produces holograms which are used to scan credit cards or price codes on products in supermarkets, on stickers that children play with, and on book covers for special effect.

Holography in short has become a subject of such vital importance around the world so rapidly that conferences are constantly being held among the experts to exchange views.

The latest of these sessions will open in Beijing today--a three-day international conference at which experts will exchange views on recent developments in the field and discuss problems in holographic application. The conference will be attended by some 250 scientists and engineers and other holographic experts from 13 countries. Meanwhile an exhibition will be held in Beijing Institute of Posts and Telecommunications from this evening through to 9 July.

Theoretical research on holography was started by Hungarian scientist Dennis Gabor in 1947. But the technique did not become practical until the 1960's when lasers were introduced to the world.

Two American scientists, Emmett Leith and Juris Upatnieks, made great contributions to holographic development. They succeeded in recording holograms that could produce highly realistic three-dimensional images with laser beams in the 1960's. Since then, the technique has developed rapidly.

"China started research on holography a little later than some foreign countries," Xu Caxiong, professor of optics from the Beijing Institute of Posts and Telecommunications, told CHINA DAILY recently. "But now we are making efforts to catch up."

Pointing to a hologram of micrometer and two gears he and his colleagues had produced in an optical lab in the institute, Professor Xu explained that a hologram had to be produced in two steps: Recording and reconstruction.

"It's just like recording a tape. First you have to record all the sound information, then you play it. Hologram making involves recording the light waves of objects," he said.

Holograms are distinguished from ordinary photos because of the three-dimensional images produced by laser beams. Dr John Caulfield of the University of Alabama in the U.S. once described looking at a hologram as "viewing a three-dimensional scene through a window: By moving to different parts of the window, we see the scene from new angles."

"Holography began as an art form. But with new development, the technique is penetrating into various areas in industry, archaeology and medicine," Xu said.

Holography and optical fibre transmission, two new optical techniques, have become closely related. In China, the holographic optical element has been used as coupler in optical fibre transmission. "And sometimes, optical fibres serve holography," Xu said, adding: "When we want to record a hologram inside a machine where laser beams cannot reach, we can use optical fibres to transmit the laser into the interior."

In the Shanghai Museum, scientists used a technique known as holographic interferometry to study ancient Chinese relics. Through the use of holograms, the scientists detected tiny cracks on ancient pottery and porcelain that the human eye could not see.

The age of an ancient water basin with a fish-shaped spout called Yuxi was discovered through the use of holograms. The basin was found to have been made in the Ming Dynasty (1368-1644).

In the same way, by using holograms, scientists studied the vibrations of a set of ancient bells, Bianzhong, which was made during the Warring States Period (475-221BC).

Supermicrofiche holographic storage is another wonder of holographic application. The technique was developed by the Tianjin Computer Institute. In the lab of Beijing Institute of Posts and Telecommunications, researchers showed how a full page of PEOPLE'S DAILY would be reduced on film to a small dot measuring two millimetres in diameter. A glass plate, no larger than an ordinary book, could be used to store three volumes of magazines, Professor Xu explained.

In his article published in NATIONAL GEOGRAPHIC magazine in March, 1984, Dr Caulfield said: "For all the progress in holography today, its future looks brighter still. By the year 2000, we will enjoy three-dimensional movies and television."

Holography has important applications in medicine, particularly in the field of X-rays which Dr Caulfield says will "offer us undreamed of detail about objects as small as viruses."

As one example, dentists from the Western China University of Medical Sciences, in cooperation with the researchers from the Institute of Radio Engineering in Chengdu, developed double-exposure holograms of a rotating tooth to provide vital information for dental diagnosis.

APPLIED SCIENCES

DEEP-WATER RESCUE VESSEL COMPLETES MAJOR MISSION TESTS

HK020245 Beijing RENMIN RIBAO OVERSEAS EDITION in Chinese 28 Jun 86 p 4

[Report: "China's First Deep-Water Rescue Vessel Completes Tests"]

[Text] China's first deep-water rescue vessel developed by China itself has completed its three major mission tests in China's sea area. They include simulated wet rescue, deep diving, and actual dry rescue from one vessel to another. Successful completion of these tests has filled gaps in our deep-water rescue technology so that China has joined the front ranks of the world in many key technological areas of manufacturing deep-water rescue vessels.

These vessels are advanced equipment that can be effectively used to rescue the crew of a submarine involved in an accident at sea. They are of great military and economic value in deep-water rescue, seabed salvaging, marine surveys and studies, and construction of various underwater projects, thus drawing the widespread attention of numerous countries in the world.

Small in size, complicated in technology, and high in construction cost, this kind of vessel can be developed and used only by a handful of industrially developed countries.

According to a JIEFANGJUN BAO report, the deep-water rescue vessel which was jointly developed by the navy, the subordinate units of the China State Shipbuilding Corporation, and the relevant institutions of higher education, was a key scientific research project of the state. The marine tests have proved that the vessel has not only topped by a big margin the previous deep-diving records set by China's manned submarines, but also succeeded in exploring a deep-water rescue plan of highly practical significance. It can not only spot, on the color screen under certain conditions, the site of a disabled submarine to enable a "dry rescue" but also, under certain specified conditions enable rescuers to go out of the vessel to guide the crew of the abandoned submarine in entering the vessel thus successfully conducting a "wet rescue." Moreover, the vessel has caught up with or approached advanced world levels in the technological performance of some equipment, such as power and depth controls.

/12913

CSO: 4008/93

## APPLIED SCIENCES

### PROGRESS IN SEISMOLOGICAL STUDIES REPORTED

OW171116 Beijing XINHUA in English 1042 GMT 17 Jul 86

[Text] Beijing, 17 July (XINHUA)--China has achieved remarkable progress in its seismological studies since the 1976 Tangshan earthquake which took a toll of 240,000 lives, Chen Yong, deputy director of the State Seismological Bureau, told XINHUA today.

China suffers from frequent continental earthquakes. It was the first country to make a successful prediction of a major tremor when it predicted a 7.3 magnitude quake which occurred in Haicheng, Liaoning province, in early February of 1975, Chen said. However, he admitted that the Chinese seismic workers failed to forecast the 7.8 magnitude 1976 Tangshan quake. "The quake gave us an unforgettable lesson. It also inspired us to work harder," Chen said.

Over the decade, he said, China has set up a large number of earthquake observation and monitoring stations to carry out studies on a variety of topics including seismic geology and crust exploration. These stations have accumulated rich data, compiled a map of the country's earthquake zones and successfully predicted a number of quakes above the intermediate level, he said. At the same time, Chen added, these stations have made or are making earthquake forecasts for large and medium-sized cities as well as zones opened to foreign investment. Remarkable social and economic results have been achieved in urban and economic construction by providing short-term predictions and other data.

So far, China has established 460 quake observation stations, employing more than 15,000 professional workers. Stations have also been set up in 446 prefectures, cities and counties manned by more than 3,100 people. In addition, there are more than 10,000 amateur observers throughout the country.

By the end of 1985, Chen said, China had invested more than 40 million yuan for the building of six large telemetric seismological networks. The Beijing network, made up of over 40 observation stations, covers an area of more than 30,000 square kilometers, he added. At the same time, 12 smaller networks have also been set up in the country which can basically monitor seismic activities in areas where quakes take place quite often.

Chen revealed that nine advanced numerical observation stations will be put into trial operation within this year, and the Beijing-Tianjin-Tangshan network, funded by the United Nations Development Program, will go into operation next year.

Over the past three years, he said, his bureau has carried out 145 research programs for large and medium-sized construction projects including the Qinshan nuclear power plant in Zhejiang province and the Ertan power station in Sichuan province.

/12913

CSO: 4010/73

APPLIED SCIENCES

SEISMOGRAPHER ANALYZES NATION'S EARTHQUAKE VULNERABILITY

OW261130 Beijing XINHUA in English 0748 GMT 26 Jul 86

[Text] Beijing, 26 July (XINHUA)--Large seismic regions, the concentration of cities in these regions and shallow quake focus constitute the three main factors that have made China the biggest earthquake victim in the world, a seismographer with some years of experience said here today.

Chen Shouliang, who is deputy chief of the office in charge of precautions against earthquakes under the ministry of urban and rural construction and environmental protection, noted that almost one third of China's entire space, or an area of 3.12 million square kilometers, belongs to seismic regions of or above seven intensity degrees.

The earthquake intensity, he explained, indicates the damage a quake causes to the ground, and its measuring differs slightly from country to country. China adopts a system of dividing it into from 1 to 12 degrees.

Chen referred the concentration of cities in seismic regions as a second factor. Half of over 300 cities in China and about 70 percent of the 20 big cities, each with a population of over one million, are located in the regions of above seven intensity degrees.

Moreover, most of the quakes occurred in China belong to those of "shallow focus" only 20 to 30 kilometers deep from the surface, which cause exceptionally great damages.

To comply with these circumstances, China is reinforcing the existing civil and industrial buildings, and stipulates that new building projects have to be installed with anti-quake facilities.

Meanwhile, plans are being drawn up to raise the capabilities of the cities for comprehensive protection against possible earthquakes, so as to reduce the damages to the minimum in case of the occurrence of quakes.

/12913

CSO: 4010/73

APPLIED SCIENCES

BRIEFS

WORLD-CLASS GYROSCOPES--Harbin 9 August (XINHUA)--High-precision equipment for testing gyroscopes passed state checks today in this capital city of northeast China's Heilongjiang Province. Gyroscopes are used in missiles, rockets, long-range aircraft guidance systems and ship's navigation systems. The newly-developed equipment, controlled by a microcomputer, can measure the moving speed of a gyroscope's central axis which results in directional error. The device was made by research workers at Harbin Engineering University after seven year's efforts. Experts say that the device is a major step toward the world advanced level in this field. [Text] [Beijing XINHUA in English 1431 GMT 9 Aug 86 OW] /12913

CSO: 4010/73

## ENVIRONMENTAL QUALITY

### TIBL AND SO<sub>2</sub> CONCENTRATION ON COAST OF DALIAN

Beijing HUANJING KEXUE [JOURNAL OF ENVIRONMENTAL SCIENCE] in Chinese Vol 6,  
No 3, 30 Jun 85 pp 19-22

[Article by Liu Wanjun [0491 5502 6511] and Gong Fujiu [1362 4395 0036],  
Liaoning Institute of Meteorology]

#### [Text] I. Introduction

In the region of medium latitude near the coast, due to the different properties of the thermodynamic and kinetic principles between land and sea, there exists a systematic pattern of air blowing inland, i.e., ocean winds which could generate a thermal internal boundary layer (TIBL) near the coastal region. The phenomenon is most pronounced in spring-summer and early autumn. The occurrence of TIBL has a significant effect on the diffusion of smoke in the coastal region that cannot be overlooked.

In the autumn of 1981, we proceeded on the observation of TIBL along the coast of Dalian, using various meteorological parameters to measure the height of TIBL and compared with the calculated values of SO<sub>2</sub> concentration using the equation of Lyons et al and the results are relatively agreeable.

#### II. Observation of TIBL

The northwestern coast of Dalian basin is an industrial region and most of the factories are concentrated in the relatively flat coastal area. When the weather system is weak, localized wind is quite noticeable due to the day/night temperature differences between the land and the ocean. We defined the wind blowing in an E-S direction as the ocean wind. In the direction vertical to the coastline, two separate observation points at a distance of 2.5 and 6 kilometers were established and the temperature and the wind direction respectively were measured with low atmosphere airometer and transit instrument. At the same time, six SO<sub>2</sub> concentration measurement points were established and a surface wind measurement point at a distance of 50 meters from the coast was set up (Figure 1).

Figure 1.

The map of the location of observation points

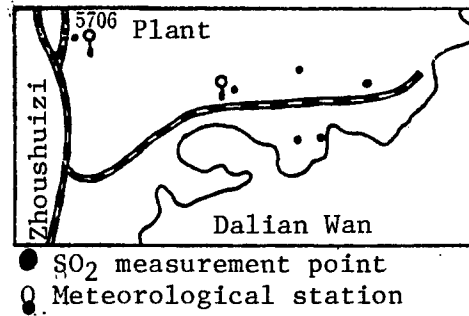

According to the analysis of the data obtained from the observation of a total of 25 days during September and October, the ocean wind changed direction at an average height of 450 meters; this generally occurred at 0800-0900 and changed to an inland breeze at 1900-2--- preceding a period of calm.

When the cold air current from the sea surface blows inland, the inland air mass begins to change, the temperature of the air layer near the land increases rapidly and the air from lower to upper layers changes to super absolute heating state or absolute heating state. As the distance from the coast increases, the air layer becomes thicker through the influence of increasing heat from land, forming the so-called TIBL. The temperature of the layers formed above and below the peak of TIBL is apparently different; the upper layer maintains the characteristic of the stable sea surface layer with the level of temperature gradient of  $\partial\theta/\partial Z > 0$ , lower layer is  $\partial\theta/\partial Z = 0$ , but the layer near the land surface is  $\partial\theta/\partial Z < 0$  which exists as super absolute heating state. TIBL would create some sort of mixed layer affecting the diffusion of the smoke.

With the occurrence of TIBL, there often associates with three kinds, A.B.,C., of stability. As long as there is air current blowing toward inland, this kind of TIBL would be maintained during daytime. Using the data obtained with low atmosphere airometer from two observation points and defined the height of  $\partial T/\partial Z > -1^\circ\text{C}/100$  as the height of TIBL, the results are given in Table 1.

Mo.	Day	Wind dir.	Wind vel.	$L(X_1)$	$L(X_2)$
9	19	E	2	250m	
9	20	S	2	300m	400m
9	21	SSE	3	220m	280m
9	22	E	3	280m	
9	23	SE	1	220m	350m
9	24	E	1	200m	400m
10	3	SSE	2	380m	500m
10	5	S	1	230m	400m
10	7	S	2		400m
10	12	S	2	200m	

Table 1.

The height of TIBL during the period of sea breeze.

The comparison is made between the actual measured height of TIBL and heights calculated using the following equation:

$$L(X) = \frac{U_*}{U} \left[ \frac{(T_A - T_w)X}{\beta_i} \right]^{1/2} \quad (1)$$

In which  $L(X)$  is the height of TIBL;  $U_*$  is the frictional velocity;  $U$  is the sea breeze's wind velocity;  $T_A$  is inland air temperature;  $T_W$  is sea surface air temperature;  $B_1$  is the vertical degressive constant of the sea surface stable air temperature level;  $X$  is the distance from the coast. Among them, the value of  $U_*$  is the result from sundown.

If 2 m/s is used as the average wind velocity of the sea breeze during the experimental period, the average temperature differences between sea surface and inland at 0800-1900 is 30°C,  $B_1$  value is 0.005°C/m, and the results of the calculation using equation (1) are shown in Figure 2. At the same time, when the measured values of average height obtained from two observation points are shown on the same figure, it can be seen that the calculated height and the measured average height are quite agreeable. This illustrates that the calculated height of TIBL using the above equation is acceptable.

Figure 2.

Comparison between actually measured and calculated height of TIBL

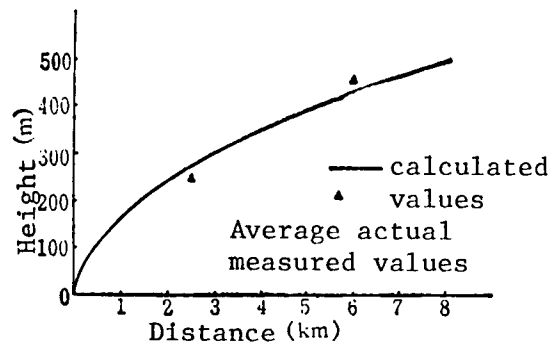

### III. Calculation of $SO_2$ Concentration

Data on the sources of origin are provided by Dalian Municipal Environmental Observation Station, meteorological data are taken from Zhou Shui Zi (0719 3055 1311) Air Port and sea temperature data are taken from Dalian Sea Information Station. Stability is classified according to the method of Pasquill-Turner. Up-grading method is used for diffusion parameters (DP). That is to raise Pasquill-Gifford's horizontal DP  $\sigma_Z$  toward the unstable direction half a scale and two scale, respectively using an extended external distance greater than 1000 meter (m). The industrial region west of Dalian coast is divided into 156 blocks each with an area of 1 Km square, and the concentration descending to the ground is estimated separately from the surface source and elevated point sources, and added them up randomly. By using wind direction, wind velocity and combined stability frequency distribution diagram, one can estimate the distribution of average seasonal and annual concentration.

If Turner's method is used to estimate the surface source and assumed that the smoke is lower than TIBL, then the smoke under this cover layer would diffuse according to the classified stability. With the smoke higher than TIBL, coming from Dalian No 2 electrical power station and No 7 petroleum refinery at elevated point sources, a special treatment is carried out and its estimate of diffusion is proceeded as shown in Figure 3.

Figure 3.

Diagram illustrating smoke diffusion

Key:

1. Profile of vertical diffusion of smoke
2. Profile of horizontal diffusion of smoke

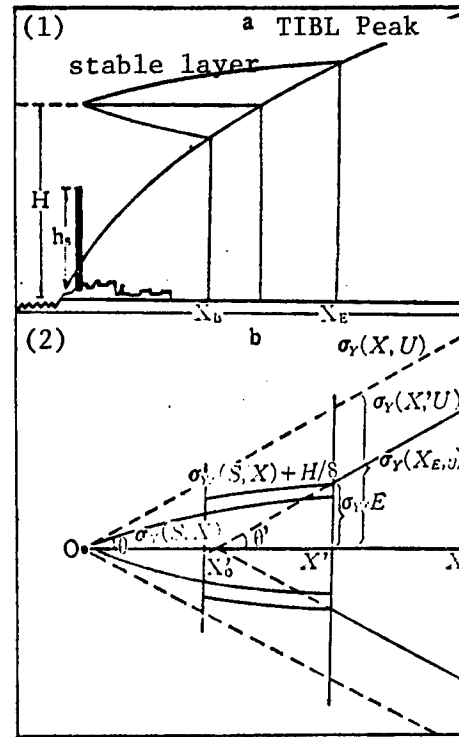

When the smoke emitting sources are higher than TIBL, the diffusion of smoke can be divided into three steps:

The first step: If the smoke has not yet entered the TIBL, i.e. before reaching  $X_B$  point, it is moving from inside stable air layer above the sea through mass flow and diffusion. Because this layer has maintained the specific characteristic of the air layer above the sea surface, it is defined as F class stability. The concentration is calculated using following equations:

$$\begin{aligned}
 \chi(X, Y, 0:H) &= \frac{Q}{\pi \bar{U} \sigma_y(X, S) \sigma_z(X, S)} \\
 &\times \exp \left[ -\frac{1}{2} \left( \frac{Y}{\sigma_y(X, S)} \right)^2 \right] \\
 &\times \exp \left[ -\frac{1}{2} \left( \frac{H}{\sigma_z(X, S)} \right)^2 \right] \quad (2)
 \end{aligned}$$

In the above equation,  $\chi$  is the concentration of pollutant,  $X$  is the downward wind distance,  $Y$  is crossward wind distance,  $0$  is the ground,  $H$  is the height of smoke,  $Q$  is the original source strength,  $\Pi$  is a constant,  $U$  is wind velocity of sea breeze,  $\sigma_y(X, S)$  is the horizontal diffusion parameter,  $S$  represents stable air layer and  $\sigma_z(X, S)$  is vertical diffusion parameter.

The second step: That is when the smoke reaches  $X_B \leq X \leq X_E$  a part of the smoke has enter the TIBL and part of it not yet. The crossing point between the upper and lower layers of smoke and TIBL is defined using the following equation:

$$\begin{aligned} L(X_E) &= H + 2.15\sigma_z(X, S) \\ L(X_B) &= H - 2.15\sigma_z(X, S) \end{aligned} \quad (3)$$

$L(X_E)$ ,  $L(X_B)$  are height of the downward wind respectively at the distance  $X_E$ ,  $X_B$  in TIBL. According to the effective height of the smoke, the positions of  $X_B$  and  $X_E$  can be determined respectively. Within the distance between  $X_B$  and  $X_E$ , the smoke diffuses according to the following equations:

$$\begin{aligned} x(X, Y, 0:H) &= \frac{Q}{\sqrt{2\pi}\sigma_{yf}(X, S)UL(X)} \\ &\times \left[ \int_{-\infty}^p (2\pi)^{-1/2} \exp\left(-\frac{p^2}{2}\right) dp \right] \\ &\times \exp\left[-\frac{1}{2}\left(\frac{Y}{\sigma_{yf}(X, S)}\right)^2\right] \end{aligned} \quad (4)$$

Among them

$$p = [L(X) - H] / [\sigma_z(X, S)] \quad (5)$$

$$\sigma_{yf}(X, S) = \sigma_y(X, S) + H/8 \quad (6)$$

$\sigma_{yf}(X, S)$  is the DP of the smoke within  $X_B \leq X \leq X_E$ , which equals to the DP of the stable air layer formed plus one eighth of the effective height of the smoke.

The third step: From  $X_E$  thereafter, all the smoke has entered the TIBL. The vertical concentration is assumed to approach uniformity. The main question here is how to reasonably select the horizontal DP. If the horizontal DP,  $\sigma_y(X, U)$  in the unstable air layer is selected based on the distance of elevated sources, it is apparently unreasonable because the unstable state would begin to affect the smoke only in between  $X_B$  and  $X_E$ . Thus it would over estimate the crossward diffusion. If there were a hypothetical point source located between  $X_B$  and  $X_E$ , and  $X'$  is the downward wind distance of this assumed point source. It is reasonable to determine  $\sigma_y(X', U)$  based on  $X'$ , and to determine the location of the hypothetical point source using geometric diagram (Figure 3b). Within the unstable air layer, there are two smoke boundary lines which are  $\sigma_y(X, U)$  and  $\sigma_y(X', U)$ , the former originated from the real source, and the latter originated from the hypothetical source  $X'_0$ .

With reference to  $X \leq X_E$ , if it is assumed that these two lines are parallel, and a simple trigonometry is used to determine  $X'_0$ , then the downward wind distance can be derived from the following equation:

$$X' = X - [X_E - (X_E - X'_0)] \quad (7)$$

Among them,  $X'_0$  can be derived from similar trigonometry:

$$\begin{aligned} \tan \theta' &= \sigma_y(X_E, U) / X_E \\ &= \sigma_{yf}(X_E, S) / (X_E - X'_0) \end{aligned} \quad (8)$$

$\theta'$  is the angle between the  $\sigma_y(X', U)$  line and the central axis of the smoke, thus:

$$X'_0 = X_E - \left[ \frac{\sigma_{yf}(X_E, S)}{\sigma_y(X_E, U)} \right] X_E \quad (9)$$

And estimates of concentrations in the third step can be made using the following equation:

$$\begin{aligned} x(X', Y, 0:H) &= \frac{Q}{\sqrt{2\pi} \sigma_y(U, X') L(X) U} \\ &\times \exp \left[ -\frac{1}{2} \left( \frac{Y}{\sigma_y(X', U)} \right)^2 \right] \end{aligned} \quad (10)$$

#### IV. Conclusion

In the non-plucking warm season during the period of mild wind, even in the day time during autumn, there exists the TIBL in the coastal region, and the descending smoke and fume had polluted the air in the coastal industrial area. This type of maximum concentration generated from continuous elevated point sources would descend to the ground positions depending on the varying height of the smoke and TIBL. With reference to No 7 petroleum refinery and No 2 electrical power station, the positions of the maximum descending  $SO_2$  concentration are 6 Km and 4 Km respectively in the downward wind direction.

Since there are multiple sources in the western coastal region of Dalian, it is impossible to proceed the observation only from a single elevated source, and thus the descending concentration from multiple sources has to be observed. The comparison between the actual measured and calculated values of daily concentration taken from four observation points in 10 days is shown in Figure 4 which has a correlation coefficient of 0.76.

Figure 4.

Comparison between calculated and actually measured values

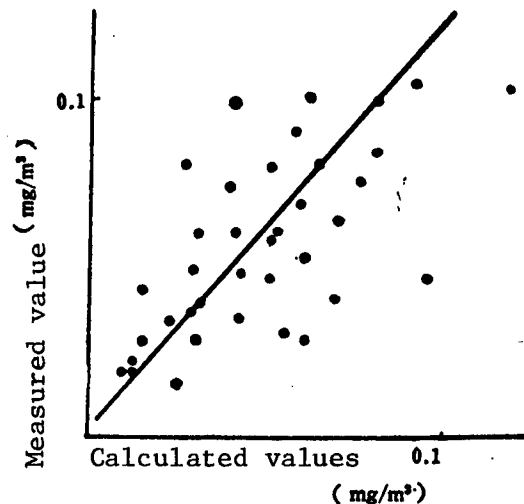

It is a fact that TIBL does exist. Under this covered layer, the problem of diffusion, transportation and transformation of the pollutants in the coastal atmospheric diffusion is one of the problems must be resolved. Our work is only a preliminary trial.

#### REFERENCES

1. W.A. Lyons and H.S. Cole, J. Appl. Meteo., 3(12), (1973).
2. Misra, Atmos. Environ., 4(14), (1980).
3. Liu Wanjun, Environ. Sci., 4(4), 20, (1983).

---

\*Han Xishan (7281 3886 1472), Wang Jingan (3769 2529 0049), Fu Guozhen (6384 0948 3791) and a number of comrades from the Dalian Municipal Environmental Protection Station participated in this work.

12865/8918  
CSO: 4008/35

SEPARATION OF CATECHOLAMINES BY MICRO HIGH-PERFORMANCE LIQUID CHROMATOGRAPHY WITH ELECTROCHEMICAL DETECTION

Beijing YAOXUE XUEBAO [ACTA PHARMACEUTICA SINICA] in Chinese Vol 20, No 11, 29 Nov 85 pp 870-873

[English abstract of article by Zou Gongwei [6760 0361 0251], et al., of Department of Chemistry, Nanjing University, Nanjing]

[Text] The separation of catecholamines has been performed by reversed-phase ion pair chromatography on a micro separation column filled with phenyl chemically-bonded stationary phase with electrochemical detector. A micro YWG C<sub>6</sub>H<sub>5</sub> column (160×0.5 mm i d, PTFE tube) was used for separation of catecholamines, the mobile phase was 50 mM KH<sub>2</sub>PO<sub>4</sub> solution of pH 4.2 containing 1.5 mM solution of 1-heptanesulphonate and 0.1 mM EDTA, at a flow rate of 5.9 μl/min and a potential of the working electrode of +0.75 V (vs Ag/AgCl), four catecholamines (noradrenaline, adrenaline, l-dopa and dopamine) were separated in 22 minutes. Both matrix and trace component can be determined simultaneously by means of a two-pen recorder connected to the detector at different sensitivity for the determination of each component. The trace of noradrenaline could still be determined when the ratio of adrenaline to noradrenaline changed from 10:1 to 100:1. (Paper received 25 Feb 85.)

REFERENCES

1. Kissinger PT, et al. An electrochemical detector for liquid chromatography with picogram sensitivity. *Anal Lett* 1973;6:465.
2. Riffin RM, et al. Determination of phenolic sympathetic stimulants in pharmaceuticals by liquid chromatography with electrochemical detection. *Ibid* 1974;7:791.
3. Goto M, et al. Electrochemical detector for micro high-performance liquid chromatography and its application to the determination of aminophenol isomers. *J Chromatogr* 1981;208:261.
4. Goto M, et al. Determination of catecholamines in human serum by micro high-performance liquid chromatographic system with micro precolumn and dual electrochemical detection. *Ibid* 1983;275:271.
5. British pharmacopoeia 1980:16~17.

/7358

CSO: 4009/1087

# STUDIES ON A NEW TYPE ACID DYE--XYLENE CYANOL FOR THE DETERMINATION OF AMINES

Beijing YAOXUE XUEBAO [ACTA PHARMACEUTICA SINICA] in Chinese Vol 20, No 12, 29 Dec 85 pp 923-930

[English abstract of article by Yu Yongxiang [0205 3057 4382] and Guo Qingdong [6753 1987 2639] of Academy of Military Medical Sciences, Beijing]

[Text] In order to increase the sensitivity of the acid dye determination method, we have tested 70 kinds of acid dyes which possess sulfonic acid or carboxylic acid radical. These dyes, including sulfonphthaleins, azo dyes, triarylmethanes, nitrophenylamines, etc., have not yet been reported in the literature for the determination of amines. It is observed that only the dyes which possess sulfonic acid radical are useful in this method. Among these dyes, 10 kinds were selected for further examination, the result shows that xylene cyanol (XC) is one of two best dyes. The limits of identification of this dye for benethtropine [1, 1-diphenyl-2 (3-tropanyl) ethene] and benactyzine (benzyllic acid 2-diethylamino-ethyl ester) are 17 ng/ml and 36 nb/ml respectively. The extinction coefficients ( $E_{1\text{cm}}^{1\%}$ ) of these dye-amine complexes are 4.2~6.2 times as high as those of bromothymol blue (BTB), but for more hydrophilic amines,  $E_{1\text{cm}}^{1\%}$  are lower than those obtained from BTB. Chloroform extract of the complex shows greenish blue color,  $\lambda_{\text{max}}$  628.5 nm. For the determination of amines, the suitable concentration of XC is  $4 \times 10^{-3}$  M. The calibration curve is a straight line in the range of 0~10  $\mu\text{g/ml}$ . With XC concentration of  $4 \times 10^{-3}$  M, the mole ratio of dye-amine complex in the chloroform extract for benactyzine is XC: Benactyzine=2.1, and with concentration of  $4 \times 10^{-4}$  M=1:1. But, in the case of benethtropine, the mole ratio with different due concentration ( $4 \times 10^{-3}$  M~ $4 \times 10^{-4}$  M) remains 2.7:1 (XC:amine). The coefficient of variance for the determination of 0.2  $\mu\text{g/ml}$  benethtropine or benactyzine is within  $\pm 5\%$  and  $\pm 1\sim 2\%$  for 2.5  $\mu\text{g/ml}$  and 5.0  $\mu\text{g/ml}$ . This dye is a new type acid dye for the determination of amines, and the following portion is considered to be the fundamental structure:

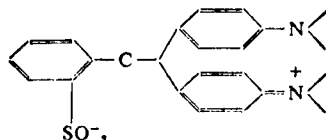

(Paper received 8 Apr 85.)

## REFERENCES

1. Modin R. Quantitative determination by ion pair extraction. Part 7. Extraction of ionizable organic compounds with ion-pairing and adduct-forming agent. *Acta Pharm Suec* 1971, 8:509.
2. 酒井忠雄. 酸性染料とキニンを用いるベルベリンの抽出光度定量. *ぶんせき* 1982, (7):493.
3. Sakai T. Spectrophotometric determination of trace amounts of quaternary ammonium salts in drugs by ion pair extraction with bromophenol blue and quinine. *Analyst* 1983, 108:608.
4. Sakai T. Extraction-spectrophotometric determination of benzethonium and benzalkonium salts with bromocresol green and quinine. *Anal Chim Acta* 1983, 147:331.

5. 俞永祥等. 酸性色素萃取法测定胺类的研究. *药物分析杂志* 1984, 4:333.
6. Gupta VD. Selection of a dye and an organic solvent for the analysis of amines. *Can J Pharm Sci* 1970, 5:44.
7. Gupta VD. Acid dye method for the analysis of amines and quaternary ammonium compounds. *Indian J Pharm* 1973, 35:77.
8. 俞永祥、郭庆东. 新类型酸性色素定量胺类化合物的研究——羊毛罂粟蓝测定胺类化合物. 待发表.
9. 俞永祥等. 溶剂抽提法分离胺类药物的研究. *药学学报* 1981, 16:594.
10. 刘纪琳、郑永章. 关于原子吸收光谱法的灵敏度、检出限和测量下限. *化学通报* 1982, (6):382.
11. 森本昌宏, 平古場朗. チオセミカルバゾドによる水中の銅 (II) の吸光光度定量. *分析化学 (日)* 1965, 14:1058.
12. Farsam H, et al. Spectrophotometric determination of codeine in pharmaceutical preparations. *Int J Pharm* 1981, 7:343.

/7358

CSO: 4009/1088

INTERLAMINAR STRESSES OF A LAMINATED COMPOSITE BAR UNDER BENDING(II)

Chongqing YINGYONG SHUXUE HE LIXUE [APPLIED MATHEMATICS AND MECHANICS] in Chinese Vol 6, No 8, Aug 85 pp 699-710

[English abstract of article by Zhang Fuzan [1728 4395 5400] of Qinghua University, Beijing]

[Text] A laminated composite bar of rectangular cross section consists of a middle portion of one material as well as upper and lower identical cover plates of another material. Couples formed by linear bending stresses act at the ends of the middle portion of the bar to cause bending. Interlaminar stresses are to be found showing how the forces are transmitted through the glued surfaces to the cover plates. [Editor's note: (I) was published in JPRS-CST-85-04 (24 Dec 85)] (Paper received 29 Sep 84.)

REFERENCES

- [ 1 ] Goland, M. and E. Reissner, The stresses in cemented joints, *Journal of Applied Mechanics, ASME*, 1 (1944).
- [ 2 ] Timoshenko, S., *The Approximate Solution of Two Dimensional Problems in Elasticity*, Collected Papers (1953).
- [ 3 ] 张福范, 拉伸杆的贴片所传递的应力, *上海力学*, 3 (1983).
- [ 4 ] 张福范, 双金属条整温器的接触热应力, *应用数学和力学*, 4, 3 (1983).

ELASTIC-PLASTIC ANALYSIS OF CYLINDRICALLY ORTHOTROPIC COMPOSITE LAMINA WITH A CIRCULAR HOLE UNDER UNIFORM PRESSURE

Chongqing YINGYONG SHUXUE HE LIXUE [APPLIED MATHEMATICS AND MECHANICS] in Chinese Vol 6, No 8, Aug 85 pp 745-753

[English abstract of article by Zhou Ciqing [0719 2945 7230] of Department of Mathematics and Mechanics, South China Institute of Technology, Guangzhou]

[Text] This paper presents the standard parametric representation of the Tsai-Hill Yield Criterion in a state of plane stress and the equation governing the stress distribution in a cylindrically orthotropic composite lamina with a circular hole under uniform pressure for the three cases: (a) elastic state, (b) limit state and (c) elastic-plastic state. The formulas for the yield pressure and the limit pressure have been obtained. (Paper received 6 Jun 83.)

REFERENCES

- [ 1 ] Nadai, A., *Theory of Flow and Fracture of Solids*, Vol. 1, McGraw Hill (1950).
- [ 2 ] Kachanov, L. M., *Foundations of the Theory of Plasticity*, North-Holland Publication Company-Amsterdam, London (1971).
- [ 3 ] Jones, R. M., *Mechanics of Composite Materials*, Scripta Book, Co., Washington, D. C., McGraw Hill, New York (1975).

/7358

CSO: 4009/1100

## THE FINITE ELEMENT ANALYSIS OF THE FLEXIBLE BEAMS AND PLATES

Chongqing YINGYONG SHUXUE HE LIXUE [APPLIED MATHEMATICS AND MECHANICS] in Chinese Vol 6, No 9, Sep 85 pp 833-844

[English abstract of article by Liu Zhenxing [0491 2973 5281], et al. of Shanghai Jiao Tong University, Shanghai, and Feng Taihua [7458 1132 5478] of Nanjing Aeronautical Institute, Nanjing]

[Text] This paper studies large deflection problem of beams and plates by the finite element method. The elongation of the middle surface caused by its rotation is considered in strain-displacement relations. The higher order terms will be reserved when strain energy is calculated. The elastic stiffness matrix, linear and nonlinear initial stress stiffness matrices are derived by the principle of minimum potential energy. Examples show that precision will be properly raised although the total storage amount and calculating time are not increased. The iterative method with comoving coordinate must be adopted to avoid parasitic rigid body motion. (Paper received 24 Apr 82.)

### REFERENCES

- [1] Przemieniecki, J.S., *Theory of Matrix Structure Analysis*, McGraw Hill Book Company (1968), 70-82.
- [2] Kabaila, A.P., Bifurcation of space frame, AFFDL-TR-70-36.
- [3] Zienkiewicz, O.C., *The Finite Element Method*, McGraw-Hill Book Company (1977), 331-337.
- [4] Timoshenko, S. and S. Winosky-Krieger, *Theory of Plate and Shells* (second edition), McGraw-Hill Book Company (1958), 113-124.
- [5] Holand, I and K. Bell, *Finite Element Method in Stress Analysis*, Technical University of Norway (1972), 475-485.
- [6] Cook, R., *Concepts and Applications of Finite Element Analysis*, John Wiley (1974), 264-266.
- [7] 华东水利学院, 《弹性力学问题的有限元法》, 水利电力出版社, (1978), 95-100.
- [8] B.B 诺沃日洛夫, 《非线性弹性力学基础》, 科学出版社 (1958).
- [9] Murray, D.W., Large deflection analysis of plate, Ph. D. Dissertation, University of Colifornia, Berkeley (1967), U. S. A.
- [10] 钱伟长, 《变分法及有限元》, 科学出版社, (1980), 490-493.
- [11] Horneisster, L.D., G.A. Greenbaum and D.A. Evenson, Large strain, elastic-plastic finite element analysis, *AIAA*, 9, 7 (1971).
- [12] 刘正兴、冯太华、李定夏, 用有限元法解加筋板壳的几何非线性问题, 南京航空学院学报, 5 (1979年).
- [13] Frisch-Fay, R., *Flexible Bars*, London Butter worch (1962).
- [14] Timoshenko, S. and J. Gere, *Mechanics of Materials*, Van Nostrand Reinhold Company (1972).
- [15] A.C. 沃耳密耳, 《柔韧板与柔韧壳》, 科学出版社, (1959).
- [16] 钱伟长、叶开沅, 《圆板的大挠度问题》, 物理学报, 10, 3 (1954).

/7358

CSO: 4009/1101

## THE MIXED MODE BRITTLE FRACTURE CRITERIA IN SLIDING MODE FRACTURE

Chongqing YINGYONG SHUXUE HE LIXUE [APPLIED MATHEMATICS AND MECHANICS] in Chinese Vol 6, No 11, Nov 85 pp 977-983

[English abstract of article by Lin Baisong [2651 2157 2646] of Central-South Institute Polytechnic University, Changsha]

[Text] It is well known that the present mixed mode brittle fracture criteria are all the opening mode fracture criteria. We consider that mixed mode brittle fracture of sliding mode fracture exists, too. Hence we propose three criteria of mixed mode brittle fracture of sliding mode fracture the radial shearing stress criterion, the maximum shearing stress criterion and the distortional strain-energy-density criterion. Thus, we can completely explain the phenomena of brittle fracture in the structural elements with cracks. (Paper received 10 Sep 82.)

### REFERENCES

- [ 1 ] Liebowitz, H., J. Eftis, and D. L. Jones, Some recent theoretical and experimental developments in fracture mechanics, *Fracture* (1977), ICF4, Waterloo, Canada, 1, 695-723.
- [ 2 ] Chisholm, D. B., D. SC. Dissertation, The George Washington University, Washington, D. C. (1975).
- [ 3 ] Sih, G. C., Strain-energy-density factor applied to mixed mode crack problems, *Int. Journ. of Fracture*, 10(1974), 305.
- [ 4 ] 林拜松, 复合型脆断的周向应力应变乘积判据, *应用数学和力学*, 5, 6(1984), 849-854.

/7358  
CSO: 4009/1102

HIGH-SPEED COMPUTATION AND DATA FLOW ARRAY OF FINE GRANULARITY

Beijing JISUANJI YANJIU YU FAZHAN [COMPUTER RESEARCH AND DEVELOPMENT] in Chinese Vol 23, No 5, 1986 pp 7-14

[English abstract of article by He Guo [0149 0948] of Wuhan Institute of Numerical Engineering]

[Text] Systolic-like arrays compose of a large number of heterogeneous processors which perform only computation tasks of fine granularity. Such arrays can produce very high throughput due to the high degree of concurrent processing. However, they generally suffer from poor versatility and limited I/O constraints. In this paper we present a methodology to improve the utility of such arrays and show two designs of typical applications as illustration. These designs, in addition to being able to keep the advantages of the usual arrays, reveal much more versatility and better practicality.) (Paper received Jun 85.)

REFERENCES

- [1] H. T. Kang, "Why Systolic Architecture" Computer, Vol. 15, No. 1, Jan. 1982, pp. 37-46.
- [2] Sun-yuan Kung, "On Supercomputing with Systolic/Wavefront Array Processors", Proceedings of the IEEE, Vol. 72, No. 7, July 1984, pp. 867-884.
- [3] K. Hwang and Y. H. Cheng, "Partitioned Matrix Algorithm for VLSI Arithmetic System". IEEE Trans. on Comp., Vol. C-31, No. 12, Dec. 1982, pp. 1215-1224.
- [4] K.Hwang and S. P. Su, "VLSI Architecture of Feature Extraction and Pattern Classification", Computer Vision, Graphics, and Image Processing, Vol. 24, Academic Press, New York, Nov. 1983 a, pp. 215-228.
- [5] Guo He and Henry Chuang, "A Practical Systolic (VLSI) Array System for Sorting & Data Base Operation", Technical Report 83-7. University of Pittsburgh, Computer Science Department, Oct. 1983. The final version is submitted to IEEE Trans. on Computer.
- [6] Henry Y. H. Chuang and Guo He, "A Versatile Systolic Array for Matrix Computations". To appear in the 12th International Symposium on Computer Architecture.
- [7] D. K. Faddeev and V. N. Faddeeva, pp. 150-158 in Computational Method of Linear Algebra. W. H. Freeman and Company (1963).
- [8] Henry Y. H. Chuang and Guo He, "Design of Problem-Size Independent Systolic Array Systems", Proceedings of ICCD'84, IEEE, Oct. 1984, pp. 152-157.

/7358

CSO: 4009/1099

LIGHT-ACTIVATED GaAs/GaAlAs HETEROSTRUCTURE NEGATIVE RESISTANCE LASERS

Shanghai ZHONGGUO JIGUANG [CHINESE JOURNAL OF LASERS] in Chinese Vol 13, No 7,  
20 Jul 86 pp 401-405

[English abstract of article by Zhang Quansheng [1728 2938 3932], et al., of  
Institute of Semiconductors, Academia Sinica]

[Text] A light-activated GaAs/GaAlAs heterostructure negative resistance laser  
has been made by horizontal liquid-phase epitaxial growth. The operation prin-  
ciple and some of the characteristics of the device are described.

## A TUNABLE ALEXANDRITE LASER

Shanghai ZHONGGUO JIGUANG [CHINESE JOURNAL OF LASERS] in Chinese Vol 13, No 7,  
20 Jul 86 pp 406-408

[English abstract of article by Zhang Guifen [1728 6311 5358], et al., of  
Shanghai Institute of Optics and Fine Mechanics, Academia Sinica]

[Text] Continuously tunable laser output at 60.4 nm in the range of 735.7 nm to 796.1 nm has been obtained in an alexandrite laser with a three-element quartz birefringent filter. The laser linewidth is about 0.001 nm when a LiF crystal as passive Q-switch is used for single pulse operation. The output energy does not decrease obviously while the oscillating threshold increases by only 5 percent.

GENERATION OF HIGH-POWER TUNABLE PICOSECOND PULSES BY SYNCHRONOUSLY PUMPED DYE LASER

Shanghai ZHONGGUO JIGUANG [CHINESE JOURNAL OF LASERS] in Chinese Vol 13, No 7, 20 Jul 86 pp 410-413

[English abstract of article by Lin Jingu [2651 6855 6253] of Institute of Physics, Academia Sinica, and Li Ran [2621 3544], et al., of Beijing University of Polytechnology]

[Text] The paper reports the study of synchronous mode-locking of dye laser which has a hemispherical resonator with a diffraction grating of R-2M radius of curvature and is pumped by the second-harmonic pulse train from an actively passively mode-locked repetitive pulsed Nd: YAG laser. A broadly tunable, high-power mode-locked dye laser source has been achieved. Real-time experimental investigation was made of some relationship governing the output characteristics of the dye laser with a BWS-5K high resolution streak camera. Brief analysis and discussion are given concerning the experimental results.

DYE LASER SYNCHRONOUSLY PUMPED BY REPETITIVE PULSE YAG LASER WITH AN AVERAGE POWER OF 1.4 mW

Shanghai ZHONGGUO JIGUANG [CHINESE JOURNAL OF LASERS] in Chinese Vol 13, No 7, 20 Jul 86 pp 414-416

[English abstract of article by Zhao Qingchun [6392 1987 2504], et al., of Shanghai Institute of Optics and Fine Mechanics, Academia Sinica]

[Text] Frequency-doubled light from a repetitive pulse and mode-locked YAG laser of thermally stable cavity was used to synchronously pump a R-6G dye laser. Experimental results obtained are as follows: average power 14 mW, peak power of single pulse over 5 MW, single pulse width 28 ps, repetition rate of pulse train 20 pps, tunable range from 555.0 nm to 586.5 nm, spectral linewidth 0.1 nm, conversion efficiency 11 percent; when the linewidth is 0.04 nm, the conversion efficiency is 8 percent.

EXPERIMENTAL INVESTIGATION OF GOLD VAPOUR LASER

Shanghai ZHONGGUO JIGUANG [CHINESE JOURNAL OF LASERS] in Chinese Vol 13, No 7,  
20 Jul 86 pp 417-420

[English abstract of article by Shan Huanyan [0830 3562 3508], et al., of  
Institute of Electronics, Academia Sinica]

[Text] A gold vapour laser has been designed and constructed. The maximum average output power obtained was 5 watts. The influences of various buffer gases (neon, helium, argon and nitrogen) and pulse repetition frequency on the output power at 627.8 nm have been studied experimentally.

ELECTRO-OPTICAL SWITCHES WITH FERRITE LINES

Shanghai ZHONGGUO JIGUANG [CHINESE JOURNAL OF LASERS] in Chinese Vol 13, No 7,  
20 Jul 86 pp 421-423

[English abstract of article by Zhu Xinming [2612 9515 6900], et al., of  
Shanghai Institute of Optics and Fine Mechanis, Academia Sinica, and Gong Jian  
[7895 0256] of Zhejiang University]

[Text] The electrical pulse sharpening effect in ferrite transmission lines  
and the dependence of transmission speed of voltage wavefront on the bias  
magnetization current have been observed in detail. Combining two sharpened  
pulses with different sign and a certain relative delay time ns, 8k V pulse  
with continously variable width have been obtained. A Pockels cell was driven  
by the pulse to slice Q-switched laser pulses.

EFFECTS OF FOCUSING PARAMETERS ON CONVERSION EFFICIENCY OF STIMULATED RAMAN SCATTERING

Shanghai ZHONGGUO JIGUANG [CHINESE JOURNAL OF LASERS] in Chinese Vol 13, No 7, 20 Jul 86 pp 428-431

[English abstract of article by Yuan Yifeng [5913 0001 7364], et al., of Shanghai Institute of Optics and Fine Mechanics, Academia Sinica]

[Text] The expression for conversion efficiency of the stimulated Raman scattering pumped by a focusing laser beam is deduced in this paper. The effects of focusing parameters on the conversion efficiency are analyzed, the calculated result shows that the optimum focusing parameters were related to the pumping power intensity. Our recent experimental results are in agreement with the above analyses.

GROWTH OF  $\text{KTiOPO}_4$  CRYSTAL FOR HIGH EFFICIENCY SHG DEVICES AND ITS MAIN PROPERTIES

Shanghai ZHONGGUO JIGUANG [CHINESE JOURNAL OF LASERS] in Chinese Vol 13, No 7, 20 Jul 86 pp 438-441

[English abstract of article by Liu Yuegang [0491 6460 1511], et al., of Institute of Crystal Materials, Shandong University]

[Text] The process of flux growth of  $\text{KTiOPO}_4$ (KTP) crystals is briefly described. The largest crystal grown is 42.5 x 42.0 x 13.6mm. With the devices made by KTP crystals in the Nd:YAG mode-locked laser, frequency-doubling conversion efficiency of the extracavity device obtained is 65.1 percent; while in quasic-W Nd:YAG laser, the average green light output obtained is 8.7W.

/7358

CSO: 4009/108

THE SANDWICH ELISA FOR THE THROMBIN-LIKE ENZYME OF AGKISTRODON ACUTUS VENOM

Beijing YAOXUE XUEBAO [ACTA PHARMACEUTICA SINICA] in Chinese Vol 21, No 2, 28 Feb 86 pp 81-85

[English abstract of article by Zhu Longxiang [2812 7893 4382], et al., of Department of Pharmacology, Fujian Medical College, Fuzhou]

[Text] Horseradish peroxidase (HRP) was used as the market and polystyrene micro-haemagglutination plates were used as the solid carrier. The EIA for thrombin-like enzyme (TLE) partially purified from the Agkistrodon acutus venom was studied with the sandwich ELISA. The sandwich ELISA for TLE was a sensitive and specific method. The minimum concentration of TLE that could be detected was as low as 1~5ng.ml<sup>-1</sup> with reproducibility. The "s"-type logarithm dose reaction curve of TLE in rat plasma was fitted on FO-3 micro-computer using the logarithm model with four parameters and BASIC program based on nonlinear least square satisfactorily. (Paper received 25 Feb 85.)

REFERENCES

1. 王晴川, 刘广芬. 蛇毒. 黄美华等主编. 五步蛇. 第1版. 北京: 科学出版社, 1983: 66~102.
2. Stocker K. Defibrinogenation with thrombin-like snake venoms. In: Markwardt. F ed *Fibrinolytics and antifibrinolytics*. Springer-Verlag, 1978: 451~484.
3. Alister V. Heterogeneous enzyme immunoassays and their applications. In: Edward T M ed. *Enzyme Immunoassay*. Florida: CRC Press Inc. 1980: 181~196.
4. 刘广芬等. 福建产尖吻蝮 (*Agkistrodon acutus*) 蛇毒的柱层析分离及酶活力和某些生理效应的测定. *动物学研究* 1980, 1: 107.
5. 云南动物研究所第四研究室. 蛇毒的研究和利用(1). 我国几种常见毒蛇的蛇毒酶活力的测定. *生物化学和生物物理学报* 1976; 8: 151.
6. Yang CC, et al. Purification of anticobrotoxin antibody by affinity chromatography. *Toxicon* 1977; 15: 51.
7. Lowry OH, et al Protein measurement with the Folin phenol reagent. *J Biol Chem* 1951; 193: 265.
8. Wilson MB and Nakema PK. Recent developments in the periodate method of conjugating Horseradish Peroxidase (HRPo) to antibodies. In: Knapp W, et al ed. *Immunofluorescence and Related Staining Techniques*. Else-Vier/North-Holland Amsterdam: 1978: 215~224.
9. Rodbard D. Automated computer analysis for enzyme-multiplied immunological techniques. *Clin Chem* 1977; 23: 112.
10. 刘广芬等. 尖吻蝮蛇毒凝血酶样酶的生化药理研究. 中国药理学会主编. 中国药理通讯 1984; 315~316.
11. Land J. Enzymeimmunoassay: techniques and uses. *Nature* 1977; 268: 483.
12. Brian RC and Eva Engvall. Enzyme-linked immunosorbent assay (ELISA): theoretical and practical aspects. In: Edward TM ed. *Enzyme Immunoassay*. Florida: CRC Press Inc. 1980: 181~196.
13. Theakston RDG. The application of immunoassay techniques, including enzyme-linked immunosorbent assay (ELISA), to snake venom research. *Toxicon* 1983 21: 341.

STUDIES ON URANIUM MOBILIZATION AGENTS. II. SYNTHESIS OF POLYAMINOPOLYCARBOXYLIC ACID AMIDES WITH CATECHOL MOIETIES

Beijing YAOXUE XUEBAO [ACTA PHARMACEUTICA SINICA] in Chinese Vol 21, No 2, 28 Feb 86 pp 148-151

[English abstract of article by Xu Meizhong [1776 5019 1813] and Xie Yuyuan [6200 3022 0337] of Shanghai Institute of Materia Medica. Academia Sinica, Shanghai]

[Text] In searching for drugs against uranium intoxication a series of 2,3-dihydroxy-N, N'-dicarboxymethyl N, N'-di (substituted phenylcarbamoylmethyl)-1,4-benzenedimethanamine (VI) was synthesized starting with 2,3-dihydroxy-1,4-benzenedimethanamine tetraacetic acid. Their ability to enhance the elimination of uranyl nitrate from animal bodies was tested and three of them (VIc, VIe and VIf) were found to be more effective than the reported uranium chelating agents, Tiron and phosphicine. (Paper received 20 Mar 85.)

REFERENCES

1. 陈文致等. 铀促排药物研究. 两种新型膦酸类螯合剂的合成. 药化学报 1984;19:865.
2. Basinger MA, et al. Tiron as an antidote for acute uranium intoxication in mice. *Res Commun Chem Patho Pharmacol* 1981;34:351.
3. Durbin PW, et al. Specific sequestering agents for the actinides 4. Removal of  $^{238}\text{Pu}$  (IV) from mice by sulfonated tetrameric catechoyl amides. *Radiation Res* 1980;81:170.
4. Ivannikov A T: Effectiveness of using aminoalkylphosphonic acids to remove uranium from an organism. *Gig Tr Prof Zabol* 1975; (5):45; *CA* 83:128235 n

/7358

CSO: 4009/1089

STUDIES ON THE ANTIBACTERIAL CONSTITUENTS IN THE FRUIT OF LAPPULA ECHINATA GILIB

Beijing YAOXUE XUEBAO [ACTA PHARMACEUTICA SINICA] in Chinese Vol 21, No 3, 29 Mar 86 pp 183-186

[English abstract of article by Wang Xiuchun [3769 4423 4783], et al., of Shenyang College of Pharmacy, Shenyang]

[Text] Sixteen constituents (I-XVI) were isolated from the fruit of *Lappula echinata* Gilib.. Eight of them were identified as palmitic acid(I), allantoin (III), adenine (VI), adenosine(VII), L-leucine(X), L-valine(XI), L-tyrosine (XII), and succinic acid(XV).(-)-Viridifloric acid (XIII) was found from natural resource for the first time. All of them were first reported to occur in the *Lappula* genus. A new compound, 1-(p-coumaroyl)- $\alpha$ -L-rhamnopyranose(XVI), was elucidated on the basis of spectral data and chemical evidence. Antibacterial experiment showed that compounds I, VI, XIII, XV and XVI were all active. Structure determination of the other compounds is still underway. (Paper received 4 Mar 85.)

REFERENCES

1. 江苏新医学院. 中药大辞典. 第一版. 上海人民出版社, 1977:2629.
2. Crowley H C, et al. The alkaloids of *Heliotropium supinum* L., with observations on viridifloric acid. *Aust J Chem* 1959; 12:694.
3. Dry Leonard J, et al. The senecio alkaloids. part IX. the synthesis and resolution of 3, 4-dihydroxy-2-methylpentane-3-carboxylic acids: viridifloric and trachelantic acid. *J Chem Soc* 1952; (5):3445.
4. 林启寿. 中草药成分化学. 第一版. 北京: 科学出版社, 1977:691~692.
5. D'silva JB and Notari RE. Kinetics and mechanisms of aqueous degradation of the anticancer agent, indicine N-oxide. *Int J Pharm* 1981; 8: 45
6. 林启寿. 中草药成分化学. 第一版. 北京: 科学出版社, 1977:126.

## A NEW COMPOUND, APIOPAEONOSIDE, ISOLATED FROM THE ROOT OF PAEONIA SUFFRUTICOSA

Beijing YAOXUE XUEBAO [ACTA PHARMACEUTICA SINICA] in Chinese Vol 21, No 3,  
29 Mar 86 pp 191-197

[English abstract of article by Yu Jin [0060 3160], et al., of Institute of Medicinal Plant Development and Institute of Materia Medica, Chinese Academy of Medical Sciences, Beijing]

[Text] Apiopaeonoside, a new compound, was isolated from the root of *Paeonia suffruticosa* Andr. Its structure was elucidated as paeonol-[D-apio- $\beta$ -D-furanosyl (1 $\rightarrow$ 6)- $\beta$ -D-glucopyranoside on the basis of spectral data, hydrolytic reaction and preparation of derivatives.

The other 5 compounds isolated were paeoniflorin, benzoylpaeoniflorin, paeonol, paeonoside and paeonolide. The physical constants and spectral data of paeonoside and paeonolide were also reported. (Paper received 8 Apr 85.)

### REFERENCES

1. 北川勲, 他. 牡丹皮の研究(第2報)牡丹皮の成分. 生薬学雑誌 1979; 33:171.
2. 刈米達夫, 他. 配糖体の研究(第7報)-牡丹皮の成分について, その1, その2. 薬学雑誌 1956; 76:917, 920.
3. Markham KR, et al. Carbon-13 NMR studies of flavonoids-III. Naturally occurring flavonoid glycosides and their acylated derivatives. *Tetrahedron* 1978; 34:1389.
4. Mahato SB, et al. Steroidal alkaloids from *Solanum khasianum*: application of  $^{13}\text{C}$  NMR spectroscopy to their structural elucidation. *Phytochemistry* 1980; 19:2017.
5. Gorin PAJ and Mazurek M. Further studies on the assignment of signal in  $^{13}\text{C}$  magnetic resonance spectra of and derived methyl glycosides. *Can J Chem* 1975; 53: 1212.
6. Watson RR and Orenstein NS. Chemistry and biochemistry of apiose. *Adv Carbohydr Chem Biochem* 1975; 31:135.
7. Bell DJ, et al. D(+)-Apiose from the monocotyledon, *Posidonia australis*. *J Chem Soc* 1951; 3702.
8. Hudson CS. Apiose and the glycosides of the Parsley plant. *Adv Carbohydr Chem* 1949; 4:57.
9. Angyal SJ, et al. Complexes of carbohydrates with metal cations IX. Synthesis of the methyl D-tagatósides, D-psicosides, D- apiosides and D-erythrosides. *Aust J Chem* 1977; 30:1259.
10. Copon B and Thacker D. The NMR spectra of some aldofuranosides and acyclic aldose acetals. *Proc Chem S* 1964; 369.
11. Ritchie RGS, et al. Carbon-13 chemical shifts of furanosides and cyclopentanols. Configurational and conformational influences. *Can J Chem* 1975; 53:1424.
12. Hulyalkar RK, et al. The chemistry of D-apiose. part II. The configuration of D-apiose in apiin. *Ibid* 1965; 43:2085.
13. Vyas DM, et al. Carbon-13 nuclear magnetic resonance spectra of some dendroketose and other furanose derivatives. *Ibid* 1975; 53:2748.
14. Angyal SJ. Complex formation between sugars and metal ions. *Pure Appl Chem* 1973; 35:131.
15. Lato M, et al. Bidimensional thin-layer chromatography of carbohydrates on silica gel impregnated with boric acid. *J Chromatog* 1968; 34:26.

## STUDIES ON THE STRUCTURE OF THE MAIN CONSTITUENT OF THE 'VANCOMYCIN' MADE IN CHINA

Beijing YAOXUE XUEBAO [ACTA PHARMACEUTICA SINICA] in Chinese Vol 21, No 3, 29 Mar 86 pp 208-212

[English abstract of article by Ling Dakui [0407 1129 1145], et al., of National Institute for the Control of Pharmaceutical and Biological Products, Beijing; North China Pharmaceutical Corporation, Shijiazhuang]

[Text] More than ten years have passed, since Chinese "vancomycin" was produced by North China Pharmaceutical Corporation. Comparing with typical vancomycin, however, Chinese "vancomycin" shows some differences in antibacterial activity and chromatographic behavior. Based on the data of nuclear magnetic resonance ( $^1\text{H}$ NMR and  $^{13}\text{C}$ NMR), fast atom bombardment mass spectrum and its methyl-leucine in the molecule of Chinese "vancomycin", but all of the other residues are the same as that of vancomycin. Consequently, Chinese "vancomycin" is actually N-demethylvancomycin. (Paper received 3 Sep 85.)

### REFERENCES

1. McCormick MH, et al. Vancomycin, a new antibiotic. I. Chemical and biologic Properties. *Antibiotics Annual 1955~1956*. New York: Medical Encyclopedia, 1956:606.
2. Williams DH, et al. Structure and mode of action studies on the antibiotic vancomycin. Evidence from 270-MHz proton magnetic resonance. *J Am Chem Soc* 1977; **99**:2768.
3. Sheldrick GM, et al. Structure of vancomycin and its complex with acetyl-D-alanyl-D-alanine. *Nature* 1978; **271**:223.
4. Convert O, et al. A  $^1\text{H}$  nuclear magnetic resonance study of the interactions of vancomycin with N-acetyl-D-alanyl-D-alanine and related peptides. *J Chem Soc Perkin 2* 1980; 1262.
5. Bongini A, et al. Assignment of the carbon-13 spectrum of vancomycin and its derivatives. *Ibid* 1981; 201.
6. Harris CM, et al. Vancomycin: Structure and transformation to CDP-I. *J Am Chem Soc* 1983; **105**: 6915.
7. 董村、张为申主编. 抗菌素研究 I. 上海科技出版社, 1962:85~91.
8. Marshall FJ, Structure studies on vancomycin. *J Med Chem* 1965; **8**:18.
9. Boeck LD, et al. N-demethylvancomycin, a novel antibiotic produced by a strain of *nocardia orientalis*, taxonomy and fermentation. *J Antibiotics* 1984; **37**:446.
10. Hunt AH, et al. A 1568A: N-demethylvancomycin. *Ibid* 1984; **37**:917.

## STUDIES ON PVC MEMBRANE THIOPENTAL SELECTIVE ELECTRODE

Beijing YAOXUE XUEBAO [ACTA PHARMACEUTICA SINICA] in Chinese Vol 21, No 3,  
29 Mar 86 pp 226-229

[English abstract of article by Shen Guoli [3088 0948 0536], et al., of Hunan University, Changsha]

[Text] PVC membrane electrodes were prepared with thiopental-hexadecyltriocetylammmonium iodide (HTOA) and thiopental-hexadecyltriphenylphosphonium iodide (HTPP) ion-pair associates as electroactive materials. The effects of the nature of associate counterion and its concentration in the membrane phase have been studied. The electrode based on thiopental-HTOA membrane shows Nernstian response range from  $1 \times 10^{-1}$  to  $1 \times 10^{-4}$ M, with an average slope of 56.0 mV/pC. The limit of detection is  $1.2 \times 10^{-5}$ M. The potentiometric selectivity coefficients of various common inorganic and organic ions including those which are similar to thiopental in structure were determined. The 0.01 M NaOH is selected as measuring medium for potentiometric measurements. The electrode was used for determining the thiopental sodium content in some injection preparations. The method is quicker and simpler than the pharmacopeia procedure. (Paper received 8 Jul 85.)

### REFERENCES

1. 中华人民共和国药典. 1977年版. 二部. 1978:319.
2. Cosofret VV, et al. Determination of some thiobarbiturates with ion-selective membrane electrodes. *Anal Lett* 1979; 12:617.
3. 沈国励等. 左旋咪唑选择性电极的研制和应用. *药物分析杂志* 1984; 4:200.
4. 沈国励等. 山莨菪碱选择性电极的研究. *药化学报* 1985; 20:151.

/7358

CSO: 4009/1089

## ANALGESIC EFFECT OF SEROTONIN AND MORPHINE IN SPINAL CORD OF THE RAT

Shanghai SHENGLI XUEBAO [ACTA PHYSIOLOGICA SINICA] in Chinese Vol 38, No 1, Feb 86 pp 19-25

[English abstract of article by Li Sijia [2621 1835 0857] and Han Jisheng [7281 3444 3932] of Department of Physiology, Beijing Medical University]

[Text] Serotonin (5-HT) and morphine were injected intrathecally to evaluate their effect on nociception as well as their possible interaction at spinal level of the rat. (1) Significant increase of the tail flick latency was observed after the intrathecal injection of 200  $\mu$ g of 5-HT or 10 $\mu$ g of morphine. These analgesic effects could be prevented by their corresponding receptor antagonists cinanserin or naloxone. (2) Cinanserin produced a dose-dependent hyperalgesic effect, suggesting the existence of a tonic activity of the descending 5-HT pathways. Intrathecal injection of naloxone had no significant effect on the tail flick latency. (3) 5-HT analgesia was not affected by large dose of naloxone (10mg/kg, sc), whereas morphine analgesia was dose-dependently attenuated by cinanserin. The latter effect might have been resulted from the hyperalgesic effect of cinanserin as could be shown when it was injected alone. The results indicate that both 5-HT and opioids are capable of producing antinociceptive effects independently via their own receptors. No evidence was obtained indicating a mutual interaction between these two neurochemical substrates at the spinal level of the rat. (Paper received 23 Apr 84, finalized 29 Nov 84.)

## REFERENCES

- [1] 韩济生、任民峰、汤健、范少光、周仲福(1980). 中枢神经介质概论. 第二版, 科学出版社, 北京.
- [2] Haber, S. and Fide, R. (1982). The distribution of enkephalin immunoreactive neuronal cell bodies in the monkey brain: preliminary observations. *Neurosci. Lett.*, **32**, 247—252.
- [3] Vogt, M. (1979). The effect of lowering the 5-hydroxytryptamine content of the rat spinal cord on analgesia produced by morphine. *Brain Res.*, **176**, 355—364.
- [4] Lee, R. L., Sewell, R. D. and Spencer, P. S. J. (1979). Antinociceptive activity of D-ala<sup>2</sup>-D-leu<sup>5</sup>-enkephalin (BW 180C) in the rat after modification of central 5-hydroxytryptamine function. *Neuropharmacology*, **18**, 711—717.
- [5] Sugrue, M. F. (1979). Effect of depletion of rat brain 5-HT on morphine induced antinociception. *J. Pharm. Pharmacol.*, **31**, 253.
- [6] Yaksh, T. H. and Rudy, T. A. (1976). Chronic catheterization of the spinal subarachnoid space. *Physiol. Behav.*, **17**, 1031—1036.
- [7] 任民峰、韩济生(1978). 一种改进的甩尾测试及其在针刺镇痛实验研究中的应用. *生理学报*, **30**, 204—208.
- [8] Schmans, C., Hammond, D. L., Ochi, J. W. and Yaksh, T. L. (1983). Pharmacological antagonism of the antinociceptive effects of serotonin in the rat spinal cord. *Eur. J. Pharmacol.*, **90**, 349—357.
- [9] Yaksh, T. L. and Rudy, T. A. (1976). Analgesia mediated by a direct spinal action of narcotics. *Science*, **192**, 1357—1358.
- [10] Carstens, E., Klumpp, D., Randic, M. and Zimmermann, M. (1981). Effect of iontophoretically applied 5-hydroxytryptamine on the excitability of single primary afferent C and A fibers in the cat spinal cord. *Brain Res.*, **220**, 151—158.
- [11] Davies, J. E. and Roberts, M. H. T. (1981). 5-Hydroxytryptamine reduced substance P response on dorsal horn interneurons: a possible interaction of neurotransmitters. *Brain Res.*, **217**, 399—404.
- [12] Botticelli, L. I., Cox, B. M. and Glostein, A. (1981). Immunoreactive dynorphin in mammalian spinal cord and dorsal root ganglia. *Proc. Natl. Acad. Sci. U. S. A.*, **78**, 7783—7786.

- [13] Hokfelt, T., Terenius, L., Kuyoc, H. G. M. and Dann, O. (1979). Evidence for enkephalin immunoreactive neurons in the medulla oblongata projecting to the spinal cord. *Neurosci. Lett.*, **14**, 55—60.
- [14] Sastry, B. R. (1979). Presynaptic effects of morphine and methionine-enkephalin in feline spinal cord. *Neuropharmacology*, **18**, 367—375.
- [15] Randic, M. and Miletic, V. (1978). Depressant actions of methionine-enkephalin and samostatine in cat dorsal horn neurons activated by noxious stimuli. *Brain Res.*, **152**, 196—202.
- [16] Jacob, J. J. C. and Ramabadran, K. (1977). Opioid antagonists, endogenous ligands and nociception. *Eur. J. Pharmacol.*, **46**, 393—394.
- [17] Goldstein, A., Fryor, G. T., Otis, L. S. and Larsen, F. (1976). On the role of endogenous opioid peptides: failure of naloxone to influence shock escape threshold in the rat. *Life Sci.*, **18**, 599—604.
- [18] Han, J. S., Xie, G. X. and Glodstein, A. (1984). The analgesic effect induced by intrathecal injection of dynorphin B in the rat. *Life Sci.*, **34**, 1573—1579.
- [19] Proudfit, H. K. (1981). Time course of alterations of morphine-induced analgesia and nociceptive threshold following medullary raphe lesions. *Neuroscience*, **6**, 945—951.
- [20] 董雨霖、周仲福、韩济生. 中枢上行性镇痛通路的研究. 科学通报, 待发表.

EFFECT OF HYPOTHALAMIC ARCUATE STIMULATION ON THE PAIN-EVOKED UNIT DISCHARGES OF THALAMIC PARAFASCICULAR NUCLEUS: A PRELIMINARY ANALYSIS

Shanghai SHENGLI XUEBAO [ACTA PHYSIOLOGICA SINICA] in Chinese Vol 38, No 1, Feb 86 pp 26-32

[English abstract of article by Chen Xiangyang [7115 0686 7122], et al., of Laboratory of Electrophysiology, Department of Physiology, Suzhou Medical College]

[Text] (1) Electrical stimulation of hypothalamic arcuate nucleus (ARC) of rats had a marked inhibitory effect on the pain discharges of cells evoked by peripheral noxious stimuli in parafascicular nucleus (PF) of thalamus, and this effect could be reversed by naloxone. (2) Transection of the dorsal half of the spinal cord did not abolish the inhibitory effect of ARC stimulation on the pain-evoked discharges of PF cells. (3) The inhibitory effect of ARC stimulation disappeared after intraperitoneal injection of PCPA (tryptophan hydroxylase inhibitor). (4) It is suggested that there exists an ascending pain modulation pathway from ARC to PF mediated by  $\beta$ -endorphinergic and serotonergic neurons. (Paper received 3 Aug 84, finalized 30 Nov 84.)

REFERENCES

- [1] Mayer, D. J., Wolfe, T. L., Akil, H., Cabder, B. and Liebeskind, J. c. (1971). Analgesia from electrical stimulation in the brainstem of the rat. *Science*, **174**, 1351—1354.
- [2] Hughes, J., Smith, T. W., Kosterlitz, H. W., Fothergill, L. A., Morgan, B. A. and Morris, H. R. (1975). Identification of two related pentapeptides from the brain with potent opiate agonist activity. *Nature*, **258**, 577—579.
- [3] Watkins, L. R. and Mayer, D. J. (1982). Organization of endogenous opiate and nonopiate pain control systems. *Science*, **216**, 1185—1192.
- [4] Bloom, F. E., Battenbery, E., Rossier, J., Ling, N. and Guillemin, R. (1978). Neurons containing  $\beta$ -endorphin in rat brain exist separately from those containing enkephalin: Immunocytochemical studies. *Proc. Natl. Acad. Sci. USA.*, **75**, 1591—1595.
- [5] Bloch, B., Bugnon, C., Fellmann, D., Lenys, D. and Gouget, A. (1979). Neurons of the rat hypothalamus reactive with antisera against endorphins, ACTH, MSH and  $\beta$ -LPH. *Cell Tissue Res.*, **204**, 1—15.
- [6] Dorsa, D. M. and Majumdar, L. A. (1983). Localization and identification of gamma-endorphin and beta-endorphin-like peptides in the hypothalamus and ventral forebrain of the rat. *Life Sci.*, **33**, 337—345.
- [7] 顾 飒、郭试瑜、龚 珊、殷伟平、印其章、张德琇、王孝媛、顾莹娣、王 刚、张建伟 (1984). 纳洛酮对刺激弓状核镇痛效应的影响. *科学通报*, **29**, 1207—1209.
- [8] 顾 飒、郭试瑜、龚 珊、殷伟平、印其章 (1986). 反复刺激下丘脑弓状核区引起耐受及其与吗啡镇痛的交叉耐受. *生理学报*, **38**, 91—95.
- [9] Basbaum, A. I., Clanton, C. H. and Fields, H. L. (1976). Opiate and stimulus-produced analgesia: functional anatomy of a medullospinal pathway. *Proc. Natl. Acad. Sci. USA.*, **73**, 4685—4688.
- [10] Belcher, G., Ryall, R. W. and Schaffner, R. (1978). The differential effects of 5-hydroxytryptamine, noradrenaline, and raphe stimulation on nociceptive and non-nociceptive dorsal horn interneurons in the cat. *Brain Res.*, **151**, 307—321.
- [11] Gerhart, K. D., Wilcox, T. K., Chung, J. M. and Willis, W. D. (1981). Inhibition of nociceptive and non-nociceptive responses of primate spinothalamic cells by stimulation in medial brain stem. *J. Neurophysiol.*, **45**, 121—136.
- [12] 张香桐 (1973). 针刺镇痛过程中丘脑的整合作用. *中国科学*, **1**, 28—52.
- [13] 罗苑荪、袁钧苏、杨善璐、端木肇夏、张香桐 (1978). 刺激丘脑中央中核对束旁核神经元痛放电的影响. *中国科学*, **4**, 456—464.
- [14] 孙明智、陈兰生、顾洪伦、成军、岳礼生 (1980). 针刺对大白鼠丘脑束旁核单位放电的影响. *生理学报*, **32**, 207—213.
- [15] 谢贻芳、乔健天 (1981). 刺激兔中脑导水管周围灰质对束旁核单位放电的影响. *生理学报*, **33**, 170—176

- [16] 张桂林、魏劲波、周玲宝、林耀民、罗政良、周兰仙、章祖陈(1979)。刺激中脑中缝核对丘脑束旁核痛敏细胞放电的影响及其在针刺镇痛中的意义。生理学报, 31, 209—218。
- [17] Andersen, E. and Dafny, N. (1983). An ascending serotonergic pain modulation pathway from the dorsal raphe nucleus to the parafascicularis nucleus of the thalamus. *Brain Res.*, 269, 57—67.
- [18] König, J. F. R. and Klippel, R. A. (1963). *The rat brain. A stereotaxic atlas of the forebrain and lower parts of the brain stem.* Williams and Wilkins Co., Baltimore.
- [19] Finley, J. C. W., Lindström, P. and Petrusz, S. (1981). Immunocytochemical localization of  $\beta$ -endorphin-containing neurons in the rat brain. *Neuroendocrinology*, 33, 28—42.
- [20] Rossier, J. P. and Bloom, F. E. (1982). Distribution of opioid peptides. In Malick, J. B. and Bell, R. M. S. (Ed), *Endorphins: chemistry, physiology, pharmacology and clinical relevance.* pp. 89—111. Marcel Dekker, New York.
- [21] Gebhart, G. F. (1982). Opiate and opioid peptide effects on brain stem neurons: relevance to nociceptive and antinociceptive mechanisms. *Pain*, 12, 93—140.
- [22] Carstens, E., Yokota, T. and Zimmermann, M. (1979). Inhibition of spinal neuronal responses to noxious skin heating by stimulation of mesencephalic periaqueductal gray in the cat. *J. Neurophysiol.*, 42, 558—568.
- [23] McClung, R. E. and Dafny, N. (1980). The parafascicular nucleus of the thalamus exhibits convergence input from the dorsal raphe and the spinal tract of the trigeminal nerve. *Brain Res.*, 197, 525—531.
- [24] Oliveras, J. L., Besson, J. M., Guilbaud, G. and Liebeskind, J. C. (1974). Behavioral and electrophysiological evidence of pain inhibition from midbrain stimulation in the cat. *Exp. Brain Res.*, 20, 32—44.
- [25] 陈向阳、顾 飒、郭试瑜、殷伟平、印其章(1984)。纳洛酮翻转刺激下丘脑弓状核对中缝背核单位活动的影响。生理学报, 36, 589—594。

TOLERANCE TO REPEATED HYPOTHALAMIC ARCUATE NUCLEUS (ARC) STIMULATION AND ITS  
CROSS TOLERANCE TO MORPHINE

Shanghai SHENGLI XUEBAO [ACTA PHYSIOLOGICA SINICA] in Chinese Vol 38, No 1,  
Feb 86 pp 91-95

[English abstract of article by Gu Feng [7357 8688], et al., of Laboratory of  
Electrophysiology, Suzhou Medical College, Suzhou]

[Text] Analgesia resulting from electrical stimulation of hypothalamic arcuate nucleus (ARC) of the rat showed tolerance with repeated exposures, this tolerance dissipated after a period of non-stimulation. The analgesic effect of morphine decreased along with the development of the ARC stimulation tolerance and then recovered along with the recovery of the ARC stimulation-induced analgesia. Tolerance to morphine reduced greatly the analgesic effect of ARC stimulation, and recovery of the ARC stimulation-induced analgesia was seen after discontinuing administration of morphine, which demonstrated cross-tolerance between morphine analgesia and the ARC stimulation-induced analgesia. These results suggest that morphine and ARC stimulation-induced analgesia might have some common mechanisms. The fact that tolerance occurred to repeated ARC stimulation indicates that ARC stimulation-induced analgesia might be mediated by release of endogenous opiate-like substances, probably  $\beta$ -endorphin. (Paper received 13 Aug 84, finalized 11 Dec 84.)

REFERENCES

- [1] 郭试瑜、殷伟平、张惠琴、印其章(1982). 大鼠下丘脑弓状核区在唇针镇痛中的作用. 生理学报, **34**, 71-77.
- [2] 顾汎、郭试瑜、龚珊、殷伟平、印其章、张德琇、王孝媛、顾董娣、王刚、张建伟(1984). 纳洛酮对刺激下丘脑弓状核镇痛效应的影响. 科学通报, **29**, 1207-1209.
- [3] 印其章、黄伟秋、钱曾年、臧玉英(1979). 麦角酰二乙胺(LSD)对唇针镇痛的影响. 生理学报, **31**, 365-369.
- [4] König, J. F. R. & Klippel, R. A., (1963). *The Rat Brain. A Stereotaxic Atlas of the Forebrain and Lower Parts of the Brain Stem.* Williams and Wilkins Co., Baltimore.
- [5] Mayer, D. J. & Hayes, R. L., (1975) Stimulation-produced analgesia: Development of tolerance and cross-tolerance to morphine. *Science*, **188**, 941-943.
- [6] 谢翠微、汤健、韩济生(1981). 持续电针引起耐受及其与吗啡镇痛的交叉耐受. 针刺研究, **6**, 270-273.
- [7] Bloom, F., Battenbery, E., Rossier, J., Ling, N. & Guillemin, R., (1978). Neurons containing  $\beta$ -endorphin in rat brain exist separately from those containing enkephalin: Immunocytochemical studies. *Proc. Natl. Acad. Sci. USA*, **75**, 1591-1595.
- [8] Loh, H. H., Tseng, L. F., Wei, E., Li, C. H. (1976).  $\beta$ -Endorphin is a potent analgesic agent. *Proc. Natl. Acad. Sci. USA*, **73**, 2895-2898.
- [9] Simantov, R., Kuhar, M. J., Uhl, G. R., Snyder, S. H. (1977). Opioid peptide enkephalin: Immunohistochemical mapping in rat central nervous system. *Proc. Natl. Acad. Sci. USA*, **74**, 2167-2171.

/7358

CSO: 4009/1094

## Surgery

### CIRCULATORY CRISIS AND ITS TREATMENT IN TOE TRANSPLANTATION

Beijing ZHONGHUA WAIKE ZAZHI [CHINESE JOURNAL OF SURGERY] in Chinese Vol 24, No 5, 22 May 86 pp 257-259, 315

[English abstract of article by Gu Yudong [7357 3768 2639], et al., of Research Unit of Microsurgery, Huashan Hospital, Shanghai Medical University, Shanghai]

[Text] Circulatory crisis in toe transplantation was reported. Based on the period of its occurrence, the condition was divided into three stages: during operation, postoperative period within 24 hours and after 48 hours. The pathologic features, the clinical investigation, the causes, the treatment and the prevention in each stage of the crisis were described.

### REFERENCES

1. Yang Dong-yue, Gu Yu-dong. Thumb reconstruction utilizing second toe transplantation by microvascular anastomosis report of 78 cases. Chinese Medical Journal 1979; 92:295~309.
2. Lister GD, et al. Reconstruction of the hand with free microvascular toe-to-hand transfer: Experience with 54 toes transfers. Plast Reconstr Surg. 1983; 71:372.

## ANALYSIS OF FAILURE IN REPLANTATION OF 34 SEVERED FINGERS

Beijing ZHONGHUA WAIKE ZAZHI [CHINESE JOURNAL OF SURGERY] in Chinese Vol 24, No 5, 22 May 86 pp 260-261, 315

[English abstract of article by Cheng Guoliang [4453 0948 5328] and Pan Dade of The 401 Hospital of People's Liberation Army]

[Text] 420 severed fingers were replanted into position in our hospital from Dec. 1978 to March 1985. Among them, 34 digits failed to survive, giving a failure rate of 8.0 percent. The causes of failure were: (1) Improper choice for replantation in 10 digits; (2) Inadequate debridement in 3 digits; (3) Poor quality of vascular anastomosis in 18 digits; and (4) Heavy smoking after operation in 2 digits. From above, it is clear that the technical faults (2, 3, in 21 digits) were the main causes of failure, constituting 61.7 percent.

On the basis of the analysis of failure, discussion was put forward in detail in every respects of causes of failure in order to improve the success rate.

NEUROVASCULAR PEDICLE LATISSIMUS DORSI FLAP TRANSFER TO SUBSTITUTE FOR PARALYZED DELTOID MUSCLE

Beijing ZHONGHUA WAIKE ZAZHI [CHINESE JOURNAL OF SURGERY] in Chinese Vol 24, No 5, 22 May 86 pp 265-266, 315

[English abstract of article by Shao Xuan [6730 1357] and Xie Wenlong[6200 2429 7893] of The 86 Hospital of the People's Liberation Army]

[Text] Two cases of paralyzed deltoid muscle caused by poliomyelitis were treated with neurovascular pedicle latissimus dorsi muscle flap transfer. The important points of this operation are: (1) The neurovascular bundle should be dissected as proximally as possible to near the axilla vasculars. (2) The latissimus dorsi muscle was transferred to the shoulder through the deep surface of the teres major muscle, making the neurovascular bundle to be located under deep surface of the teres major muscle. (3) the distal muscular part of the latissimus dorsi muscle flap was sutured to the deltoid muscle's origin from the spine of the scapula, clavicle and acromion and the tendinous insertion of the latissimus dorsi muscle was inserted and attached to the deltoid muscle insertion on the humerus. One case followed up over 7 months, has obtained excellent function of the shoulder: abduction being restored to 90 degrees, flexion to 90 degrees, elevation to 40 degrees and extension to 30 degrees.

REFERENCES

1. Hass SL. The treatment of permanent paralysis of the deltoid muscle. JAMA 1935; 104:19.
2. Saha AK. Surgery of the paralyzed and flail shoulder. Acta orthop scand Suppl 1957; 17:25.
3. Lai MF, et al. Shoulder defect cover with functional restoration using the latissimus dorsi myocutaneous flap: a case report. Brit J Plast Surg 1982; 35:140.

TRANSPOSITION OF VASCULAR PEDICLED SCAPULAR FLAPS FOR THE REPAIR OF DEFECTS OF THE PROXIMAL HUMERUS AND ARTHRODESIS OF THE SHOULDER JOINT

Beijing ZHONGHUA WAIKE ZAZHI [CHINESE JOURNAL OF SURGERY] in Chinese Vol 24, No 5, 22 May 86 pp 267-268, 315

[English abstract of article by Yang Limin [2799 4539 3046], et al., of The 175 Hospital of People's Liberation Army]

[Text] Vascular pedicled scapular flaps were used in the repair of three cases of defects of the proximal humerus and one case of arthrodesis of the shoulder joint. The results were all satisfactory. The vascular pedicled flap in the lateral border of the scapula was about 9 cm long and the bone graft from the scapula was about 12 cm in length. The anatomic feature of this graft was especially suitable for the transposition to the superior part of the humerus and to the shoulder joint.

REFERENCES

1. 杨立民, 等. 肩胛骨骨皮瓣吻合血管移植. 解放军医学杂志 1983; 8(4):253.
2. 杨立民, 等. 肩胛旁皮瓣的临床应用和解剖学研究. 解放军医学杂志 1983; 8(5):326.
3. 钟世镇, 等. 吻合血管肩胛骨移植的解剖学研究. 临床应用解剖学杂志 1983; 1(1):3.

FACTORS AFFECTING THE SURVIVAL RATE OF SEVERE BURN INJURY

Beijing ZHONGHUA WAIKE ZAZHI [CHINESE JOURNAL OF SURGERY] in Chinese Vol 24,  
No 5, 22 May 86 pp 305-307, 319

[English abstract of article by Yang Zongcheng [2799 1350 1004] and Li Ao[7812 7663]  
of Southwestern Hospital. Third Military Medical College]

[Text] Sixty-nine adult patients with TBSA over 80 percent and/or third degree burn over 50 percent were analyzed. It was found that the average total amounts of early fluid replacement in survival group (37 cases) and nonsurvival group (32 cases) were approximately the same. Escharectomies were performed in most patients. However as compared with the survival group, patients who did not survive sustained more extensive burn injury, higher incidences of shock, sepsis and organ failure, delayed fluid resuscitation, and unsatisfactory management of burn wound in most cases. In this group, organ failure occurred before operation in 13 patients, and 12 of them died during the operative day or one day after: skin grafts failed in 14 patients and myonecrosis was found in 10 patients. The predominant factor leading to early death was organ failure, and the primary cause of late death was sepsis. Inhalation injury and shock, especially those with inadequate fluid resuscitation, were two significant factors leading to organ failure. The organ failure was predisposed to late sepsis. Moreover, improper treatment of burn wound was also the cause of late sepsis.

/7358

CSO: 4009/1093

END