

191065

JPRS-CST-86-018

12 MAY 1986

China Report

SCIENCE AND TECHNOLOGY

19981021 080

EXEMPTION CATEGORY A
Approved for public release
Distribution Unlimited

DTIC QUALITY INSPECTED 3

FBIS FOREIGN BROADCAST INFORMATION SERVICE

Reproduced From
Best Available Copy

REPRODUCED BY
NATIONAL TECHNICAL
INFORMATION SERVICE
U.S. DEPARTMENT OF COMMERCE
SPRINGFIELD, VA. 22161

4
65
A04

NOTE

JPRS publications contain information primarily from foreign newspapers, periodicals and books, but also from news agency transmissions and broadcasts. Materials from foreign-language sources are translated; those from English-language sources are transcribed or reprinted, with the original phrasing and other characteristics retained.

Headlines, editorial reports, and material enclosed in brackets [] are supplied by JPRS. Processing indicators such as [Text] or [Excerpt] in the first line of each item, or following the last line of a brief, indicate how the original information was processed. Where no processing indicator is given, the information was summarized or extracted.

Unfamiliar names rendered phonetically or transliterated are enclosed in parentheses. Words or names preceded by a question mark and enclosed in parentheses were not clear in the original but have been supplied as appropriate in context. Other unattributed parenthetical notes within the body of an item originate with the source. Times within items are as given by source.

The contents of this publication in no way represent the policies, views or attitudes of the U.S. Government.

PROCUREMENT OF PUBLICATIONS

JPRS publications may be ordered from the National Technical Information Service, Springfield, Virginia 22161. In ordering, it is recommended that the JPRS number, title, date and author, if applicable, of publication be cited.

Current JPRS publications are announced in Government Reports Announcements issued semi-monthly by the National Technical Information Service, and are listed in the Monthly Catalog of U.S. Government Publications issued by the Superintendent of Documents, U.S. Government Printing Office, Washington, D.C. 20402.

Correspondence pertaining to matters other than procurement may be addressed to Joint Publications Research Service, 1000 North Glebe Road, Arlington, Virginia 22201.

12 MAY 1986

CHINA REPORT

SCIENCE AND TECHNOLOGY

CONTENTS

PEOPLE'S REPUBLIC OF CHINA

NATIONAL DEVELOPMENTS

Shanghai Endeavors To Develop High Technology (XINHUA, 17 Apr 86).....	1
Henan Holds Science, Technology Work Conference (Henan Provincial Service, 15 Apr 86).....	2
Reform of Chinese Computer Industry Urged as Inventory Grows (Hu Sigang; CHINA DAILY, 11 Jan 86).....	3
Pharmaceutical Industry To Receive Backing From Defense Industry (Zhu Ling; CHINA DAILY, 16 Apr 86).....	5
Exploitation of Guangdong Mountain Regions Urged (Guangdong Provincial Service, 11 Apr 86).....	7
PRC To Standardize Traditional Medicine (XINHUA, 15 Apr 86).....	8
Briefs	
Research Funding Applications Accepted	9

APPLIED SCIENCES

New Work in Microprogram Level Automated Design (Li Minghui; XIAOXING WEIXING JISUANJI XITONG, No 4, 8 Apr 8).....	10
Fault Diagnostic Techniques, Diagnostic Instrument (Qian Xianggen, Zhu Aiping; XIAOXING WEIXING JISUANJI XITONG, No 5, 8 May 85).....	24

ABSTRACTS

COMPUTER APPLICATIONS

JINSHU RECHULI [HEAT TREATMENT OF METALS] No 10, Oct 85..... 38

COMPUTER DEVELOPMENT, APPLICATION

NANJING GONGXUEYUAN XUEBAO [JOURNAL OF NANJING INSTITUTE OF
TECHNOLOGY] No 1, 20 Jan 86)..... 43

ELECTRONICS

NANJING GONGXUEYUAN XUEBAO [JOURNAL OF NANJING INSTITUTE OF
TECHNOLOGY] No 1, 20 Jan 86)..... 44

ENGINEERING

NANJING GONGXUEYUAN XUEBAO [JOURNAL OF NANJING INSTITUTE OF
TECHNOLOGY] No 1, 20 Jan 86)..... 45

MATHEMATICS

NANJING GONGXUEYUAN XUEBAO [JOURNAL OF NANJING INSTITUTE OF
TECHNOLOGY] No 1, 20 Jan 86)..... 47

BEIJING DAXUE XUEBAO (ZIRAN KEXUE BAN) [ACTA SCIENTIARUM
NATURALIUM UNIVERSITATIS PEKINENSIS] No 3, May 85)..... 50

PHYSICAL CHEMISTRY

BEIJING DAXUE XUEBAO (ZIRAN KEXUE BAN) [ACTA SCIENTIARUM
NATURALIUM UNIVERSITATIS PEKINENSIS] No 3, May 85)..... 52

PHYSICS

BEIJING DAXUE XUEBAO (ZIRAN KEXUE BAN) [ACTA SCIENTIARUM
NATURALIUM UNIVERSITATIS PEKINENSIS, No 3, May 85)..... 55

POLYMERS, POLYMERIZATION

GAOFENZI TONGXUN [POLYMER COMMUNICATIONS] No 6, Dec 85)..... 56

NATIONAL DEVELOPMENTS

SHANGHAI ENDEAVORS TO DEVELOP HIGH TECHNOLOGY

OW172304 Beijing XINHUA in English 1849 GMT 17 Apr 86

[Text] Shanghai, 17 April (XINHUA) -- Shanghai, the largest industrial city in China, is striving to develop its high-tech industry to keep its position as China's economic leader, a city official said here today.

So far, Shanghai is capable of turning out 10 million large-scale integrated circuits and more than 30,000 km of optic fiber cable.

One third of the national output of organic and inorganic materials such as composite, special macromolecule materials, artificial crystals and high-temperature ceramics are produced in Shanghai, according to the official.

Recently, the Shanghai Municipal Government announced a program to build its own "silicon valley." Construction for an imported large-scale integrated circuit assembly line is underway.

Meanwhile, Shanghai is also building a dozen laboratories for application of the available scientific and technological findings, the official said.

So far, more than 13,000 microcomputers are operating in the city's textile, communication, transport, chemistry, machine building and metallurgical enterprises.

Shanghai decided to develop its high-tech industry last year when many of its century-old famous-brand products were losing attraction in both the domestic and international markets.

A study by 1,600 scholars suggested giving priority to micro-electronics, new materials, bio-engineering, optic-fiber communication, lasers and marine engineering.

/12929
CSO: 4010/1039

NATIONAL DEVELOPMENTS

HENAN HOLDS SCIENCE, TECHNOLOGY WORK CONFERENCE

HK170312 Zhengzhou Henan Provincial Service in Mandarin 2300 GMT 15 Apr 86

[Text] At the provincial science and technology work conference which ended on 14 April, Provincial Vice Governor Qin Kecai pointed out that the province has set a clear target and made a plan for this year's science and technology work. The scientific and technological personnel in the province must enhance their vigor, work hard, and seriously carry out the plan.

The conference decided that this year, the province must persevere in science and technology reform, continue to open up technological markets, and implement the principle of lifting restrictions, enlivening science and technology work, and giving assistance and guidance. In the course of reform, we must further develop scientific research-production combinations; give full play to the technological superiority of central units located in Henan; and continue to organize, support, and encourage scientific research units, higher learning institutes, and defense industrial units to establish various extensive kinds of organizations combining scientific research and production with factories and enterprises, particularly medium-sized and small enterprises and township enterprises, so as to give play to strong points and avoid short ones, to complement each other, and to form new strong points.

Comrade Qin Kecai also called for a good job in promoting and applying scientific and technological achievements. He said: Not only must scientific and technological achievements of the province be promoted, but advanced technology of other provinces and foreign countries must also be promoted and applied selectively. It is necessary to bring science and technology to the rural areas, mountainous areas, old revolutionary base areas, and poor areas.

/12712

CSO: 4008/2097

NATIONAL DEVELOPMENTS

REFORM OF CHINESE COMPUTER INDUSTRY URGED AS INVENTORY GROWS

HK110458 Beijing CHINA DAILY in English 11 Jan 86 p 3

[By Hu Sigang]

[Text] As China's computer industry grows, a lack of co-ordination in research, production and management has led to stockpiling of computers and low usage.

According to official statistics, 32,000 microcomputers were produced last year in China, while 40,000 are stocked in warehouses owing to lack of trained personnel to operate them.

In Beijing, 3,000 microcomputers worth 80 million yuan (\$24 million) are waiting to find a market. As a result, some computer factories are operating at below capacity, according to Lu Shouqun, an electronics official of the Beijing municipal government.

There are 20,000 computers of various kinds in use in Beijing one-fifth of the country's total. Although Beijing's population is only one-hundredth of the nation's. Of the 20,000, microcomputers is only 26 percent. The national average is even lower, around 15 to 20 percent, Lu said.

The problem lies in a shortage of trained personnel and an irrational distribution of technicians and computer specialists, he explained.

Computers, big or small, sophisticated or simple, are being widely applied in many areas, including bookkeeping, stock inventory, production control, Chinese character word-processing, product design, medical diagnosis, traffic control and even match-making.

Many institutes are doing research on computers. But without exchange of information and experience, they all start from scratch, repeating what has already been done, according to Lu, who is head of the Beijing Office of Electronics Development.

"A lot of time, money and manpower have thus been wasted," he said.

Computer scientists have urged reform of the computer industry management and the development of new types of computers. The state is considering setting

up a center with people from five ministries to co-ordinate the industry's growth, according to Lu.

Beijing has 28,000 computer specialists, one-third of the country's total. Seven thousand of the country's 150,00 computer research projects are being undertaken by institutes in Beijing.

The computer industry has a bright future in China with a potentially huge market, Lu said. For instance, 230 high schools and elementary schools [word indistinct] offer computer courses, using 2,200 computers. The municipal government aims to open computer courses in all 850 high schools, Lu said. "We still have a lot to do."

An exhibition of computers will be held by the Beijing Office of Electronics Development from next Tuesday through Sunday. More than 50 organizations, including all ministries, army units research institutes and universities in Beijing, will participate and present their products, Lu said.

/12929

CSO: 4010/1039

NATIONAL DEVELOPMENT

PHARMACEUTICAL INDUSTRY TO RECEIVE BACKING FROM DEFENSE INDUSTRY

HK160842 Beijing CHINA DAILY in English 16 Apr 86 p 1

[By Staff Reporter Zhu Ling]

[Text] Shenzhen -- China's pharmaceutical industry is embarking on a major modernization campaign, with the country's defense industries backing the effort.

A giant inter-ministry and inter-regional corporation is to be launched next month in Beijing to coordinate the joint development of pharmaceutical production technology.

This signals the start of a drive to update the industry which is long overdue, said an official of the State Pharmaceutical Administration.

He told CHINA DAILY the new company would undertake scientific research, design and manufacture of pharmaceutical production lines and be sponsored by the State Pharmaceutical Administration and the ministries of astronautics and aviation industries.

The move to speed up the development of a wide range of pharmaceutical technology, currently a weak sector in the economy, would help reduce the country's reliance on expensive imports, which have cost China more than \$20 million over the past six years, the official said.

The imports have come from the United States, Federal Germany, Britain, Japan and Italy.

China now has 2,000 pharmaceutical factories, most of which are still of 1940's technical standards. Another 2,000 factories producing Chinese traditional medicines are even more backward. Most of their work is still done by hand, the official said.

The Ministries of Astronautics and Aviation Industries have chosen 14 of their top research institutes and factories to help with the modernization drive.

Most of these units have been involved in the development of such high-tech products as military aircraft, radar equipment and guided missiles.

"These military-oriented enterprises, which are unfamiliar with pharmaceutical technology, will cooperate with the factories that produce pharmaceutical equipment," said the official.

The first task, he said, was to digest the technology introduced from abroad.

The immediate focus will be on the development of production lines up to advanced world standards, he said.

"We also plan to boost our ability to turn out advanced pharmaceutical production equipment for export," he said.

The establishment of the corporation is part of the national trend of "horizontal cooperation" between different enterprises and regions, cutting through previous administrative barriers.

/12929

CSO: 4010/1039

NATIONAL DEVELOPMENTS

EXPLOITATION OF GUANGDONG MOUNTAIN REGIONS URGED

HK151252 Guangzhou Guangdong Provincial Service in Mandarin 1000 GMT 11 Apr 86

[Text] After conducting a survey for 2 years in mountainous areas in northern Guangdong, the fourth squad of the South China Mountainous Areas Scientific Research Team of the Chinese Academy of Sciences held a meeting in Shaoguang City from 8 to 11 April to report their findings. It recommended measures for exploiting natural resources in mountainous areas in northern Guangdong, and called for building Shaoguang City into one of the pioneers in exploiting mountainous areas in south China.

In accordance with the arrangements made by the State Planning Commission and the Chinese Academy of Sciences, in January 1983 the Guangzhou branch of the academy and the Guangdong Provincial Science Academy set up the fourth squad of the South China Mountainous Areas Scientific Research Team of the Chinese Academy of Sciences. Over the past 2 years or so, 70 scientific and technological personnel of 14 professional groups of the squad travelled mountains and rivers in northern Guangdong to conduct in-depth scientific research, achieving gratifying results.

At the report meeting they presented 18 research reports on special subjects, in which they provided a vast amount of new information about natural resources and social and economic conditions in northern Guangdong. The research indicates that mountainous areas in northern Guangdong have all the advantages of a mountainous area in south China and are well-known places affluent in nonferrous metals and are base areas for developing forestry. According to the findings of the research, the squad believed that in developing the economy, Shaoguang City should give full play to its advantages of a mountainous area, set up an economic system with various ecotypes with the stress on forestry, bring about more intensive industrial and agricultural production at a higher level, and be a pioneer in exploiting mountainous areas in south China.

/12712
CSO: 4008/2097

12 May 1986

NATIONAL DEVELOPMENTS

PRC TO STANDARDIZE TRADITIONAL MEDICINE

OW151421 Beijing XINHUA in English 0758 GMT 15 Apr 86

[Text] Beijing, 15 April (XINHUA) -- The Ministry of Public Health has decided to standardize the prescriptions and names of prepared traditional Chinese medicines, according to a spokesman for the Ministry.

The spokesman described the names and prescriptions of the over 6,000 kinds of prepared traditional medicines as "seriously confused."

For example, the antiphlogistic tablets of herbs and rographitis, a medicinal herb, have nine different names according to the different procedures.

As a result, doctors find it difficult to administer the drugs and patients are unsatisfied with the results after being prescribed the wrong type of medicine.

Pharmaceutical factories turn out 6,499 kinds of prepared herbal medicine, including pills, tablets, powders and injections.

Among them, "a considerable number" are irrational in prescription and their effects cannot be determined, while others lose their reputations because of the confusion. Only about 1,000 kinds are used frequently now.

The spokesman said that the Ministry plans to stipulate general standards by the end of this year, and provincial health departments should formulate long term standards of some varieties.

After unification of prescriptions and names, the drug control departments under the Ministry will re-issue licenses to pharmaceutical factories.

/12929

CSO: 4010/1039

NATIONAL DEVELOPMENTS

BRIEFS

RESEARCH FUNDING APPLICATIONS ACCEPTED--Beijing, 14 Apr (XINHUA)--A responsible person of the State Natural Science Funding Commission announced here today that the commission has begun accepting applications for 1986 state science grants. The establishment of the State Natural Sciences Funding Commission is an important reform in China's science funding system. Its money will be spent in support of basic natural science research and basic applied science research throughout the country. All departments, regions, and units may submit applications by observing regulations, and may receive funds if their research projects merit support and they themselves lack funds to conduct those projects. The responsible person said: This year, the funds for supporting basic research and basic applied science research will be double that of last year. [Excerpts] [Beijing XINHUA Domestic Service in Chinese 0849 GMT 14 Apr 86 OW] /12712

CSO: 4008/2079

APPLIED SCIENCES

NEW WORK IN MICROPROGRAM LEVEL AUTOMATED DESIGN

Shenyang XIAOXING WEIXING JISUANJI XITONG [MINI-MICRO SYSTEMS] in Chinese
No 4, 8 Apr 85 pp 34-43

[Article by Li Minghui [2621 2494 1979], Dalian Institute of Technology
"CADSMDS, a Computer-Aided Design System for Microprogrammed Digital Systems"]

[Text] Abstract: The purpose of the computer-aided design system for microprogrammed digital systems--CADSMDS--that we have developed and produced is for use in the computer-aided design and computer-aided teaching of the structure of digital systems (chiefly microprogrammed computers). It is currently made up of three major parts: general microcode generated systems--GMCGS¹; register transfer level hardware description language--RTLDL and its translator²; and the general microprogram level simulation system--GMSS. For the most part, this paper discusses the system structure and theory of CADSMDS, the composition and design methods of GMSS, and application examples of CADSMDS. The entire system has been implemented on a CROMEMCO-II.

I. Introduction

We have already done much research work on digital systems aided design, and here we will only discuss why we wanted to research and produce a computer-aided system for microprogrammed digital systems. Because of the development of LSI circuits (especially bit-slice devices), microprogramming is still one of the important methods of structuring digital systems controllers, and at present, computer-aided design tools for microprogram design chiefly use microprocessor assembly language exclusively, but can only produce microcode, and have no simulation or testing functions; hardware description languages can conveniently describe and simulate hardware structure and functions, but usually they cannot directly generate optimized microcode. In order to create a general purpose, effective computer-aided design tool at the microprogram level, we have dealt separately with the microinstruction format and microprogram design of digital systems and with hardware structure and functions. We use the GMCGS to describe the former, as well as to create microstructure data tables and micro object programs, and we use the RTLDL to describe the latter, as well as to create structure data tables and function simulation subroutines. These have both independence and the ability to be linked together through the GMSS for simulation of an entire digital system.

The chief characteristics and functions of CADSMDS are:

- (i) it is suitable for use in any microprogrammed digital system;
- (ii) by using GMC GS we can conveniently describe microinstruction formats and microprogram level algorithms, to automatically generate structure data tables and object code for microprograms;
- (iii) we use the RTL DL language to describe hardware structure and functions, and generate structure data tables and FORTRAN function simulation subroutines;
- (iv) we simulate the system through use of GMSS;
- (v) when microinstruction formats or digital systems structures change, all one needs to do is change the corresponding simulation in the source program, as there is no connection between the translator and the simulation system itself; the user can conveniently use CADSMDS for simulation, testing, verification, and revision of the designed system.

II. The System Structure and Principles of CADSMDS

In this section we discuss briefly the design philosophy, system structure, and operating principles of CADSMDS, where Figure 1 is the system structure flowchart of this system.

GMC GS is at the upper left corner of Figure 1, and it includes translation routines for the microinstruction format definition language. It translates the source program describing the microinstruction formats as written in the microinstruction format definition language into microstructure data table files. GMC GS also includes a general microassembler program, which translates microassembly programs into object microprogram files according to the microstructure data tables. At the upper right corner is the RTL DL language translator, which translates the RTL DL language source program describing the system hardware modules into FORTRAN IV source program files, at the same time generating digital system structure data table files. These files reject mutual relations between the digital system hardware modules. The RTL DL language translator also generates general variable table files. Below all this is a generating program for hardware mapping and scheduling routines, which automatically generates digital system hardware structure mapping based on the structure data table files and microstructure data table files that are input. It also produces system command interpretation routines and call statements for hardware module function routines, and what it produces is specification statements and subroutine call statements for FORTRAN routines; the system command translation routines are a fixed, unchanging part of the system and provided by the system; hardware module function routines are done through FORTRAN subroutines generated by the RTL DL translator. The GMSS is what compiles and links these three portions of FORTRAN routines to the generated object programs (for details, see below).

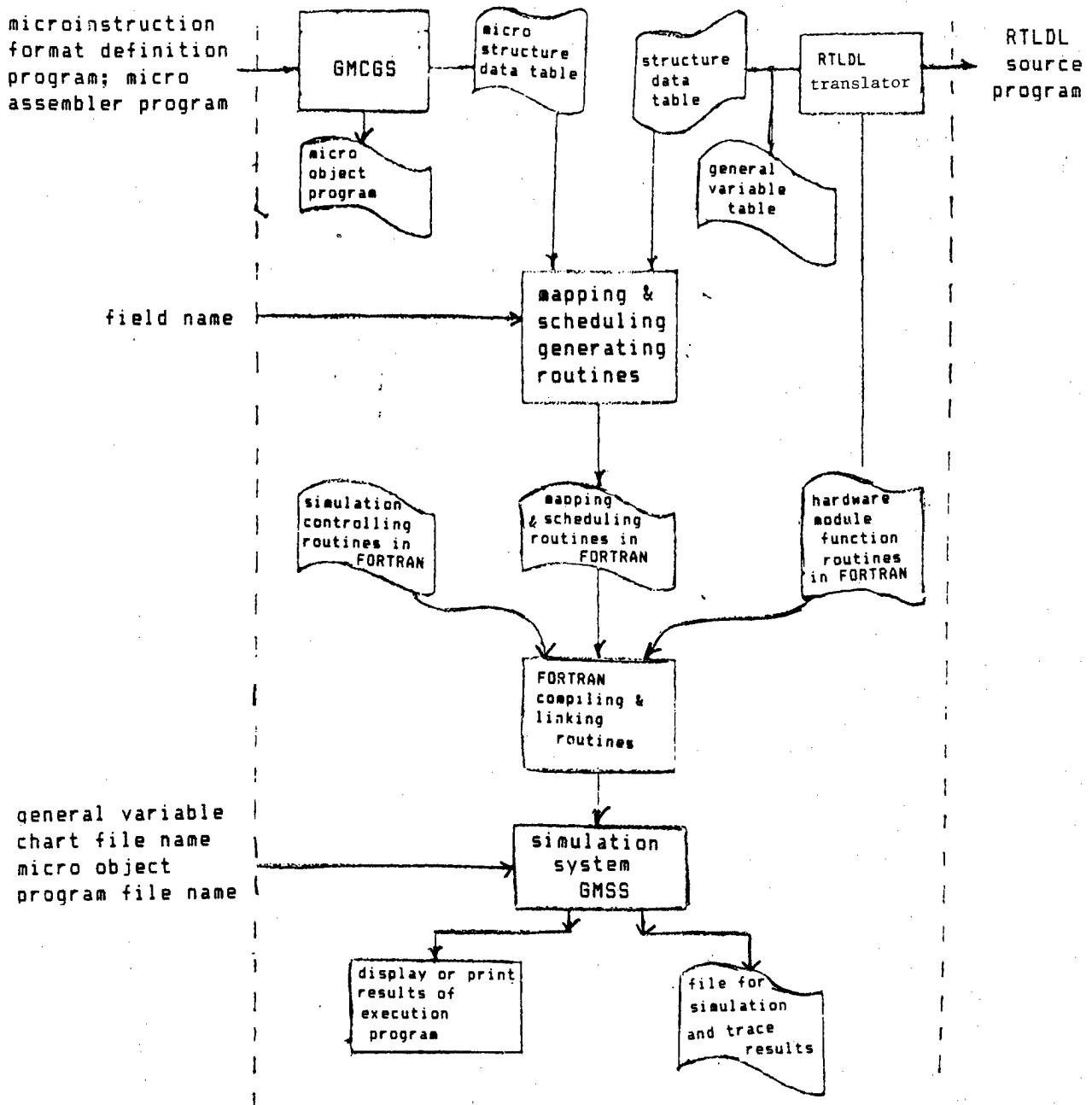

Figure 1. Flowchart for CADSMDS System Structure

GMSS has the function of generally simulating a system. If a general variable table filename and the object program filename of a microprogram are given as its input, it can translate, execute, and test the original microprogram code under the control of interactive commands, as well as generate a trace results file, all to aid the user in simulation, testing, and verification of hardware structures. This makes digital systems design more convenient, and is an effective tool for aiding the design of digital systems.

The portions outside the dotted lines in Figure 1 are for interactive use by the user and the system, while operations within the dotted line are done automatically by the program. With CADSMDS, the task of the systems designer is reduced to the following items:

(i) design hardware structure and microinstruction formats based on system design goals; (ii) use the microinstruction format description language in the GMCGS and the RTLDL language to describe and compile, respectively, microinstruction formats and hardware modules; (iii) automatically produce a GMSS system; (iv) use the general assembler language in the GMCGS to describe the various algorithms, as well as to translate into micro object programs, then simulate, test, and revise in the GMSS.

Also, if after all modules in LSI circuit series (like the Am2900 series) are described with the RTLDL language they then generate a FORTRAN program library, which can greatly reduce the amount of hardware descriptive work.

III. Structural Principles of the General Microprogram Level Simulation System--GMSS

3.1 The basic principles of GMSS

Besides the basic function of a dedicated simulator that a general simulation system must have, the key is in its having universality, that is, that it can automatically change along with changes in system hardware structure, and therefore, we can divide a general simulation system into three basic parts: a portion that is a man-machine interactive command interpreter, micro object program loader, and microinstruction interpreter. The function of this portion is the same, even for different hardware structures, only the object of processing (register unit) is different; the hardware function simulation routines generate FORTRAN routines through the RTLDL translator, which then transfer and process data in the register unit under control of the micro commands; by hardware mapping is meant units with register capabilities in the system, as for example registers, memory, and control memory. On the display of the simulation system it uses FORTRAN specification statements within GMSS, together with display, as shown in Figure 2. It can be seen from this that the first and second parts are indirectly connected to the system hardware structure, that they have a certain independence, and can be regarded as FORTRAN subroutine processors. Their relation to hardware structure can be realized through subroutine call statements in a combination of dummy and real modes. This then changes the problem of creating a general simulation system into a situation whereby existing data structures automatically generate hardware mapping and simulation system command subroutine call statements, and hardware module function subroutine call statements (that is, the central part of Figure 2), which are also FORTRAN routines. All three parts have both independence and interrelated routine systems that constitute module structures--GMSS.

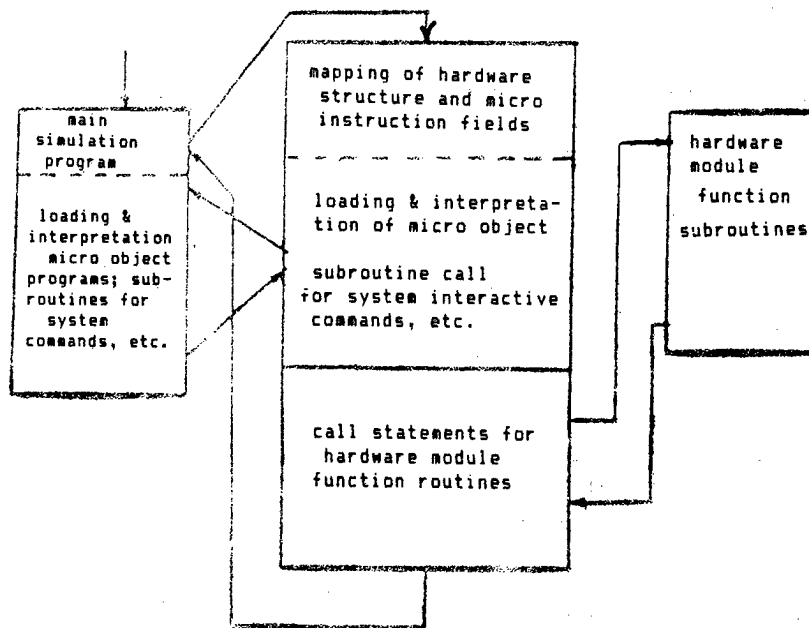

Figure 2. Flowchart for GMSS Structure

3.2 Automatic generation programs for hardware mapping and call statements

We discuss below the basic design philosophy by which the GMCGS generates microstructure data tables and the RTLDL translator generates structure data tables, which automatically generate hardware mapping and call statement routines.

It is defined in the RTLDL language syntax structure that the internal functions of hardware units (modules) and the connections between hardware units are described separately, and that connections between units reflect the structures of digital systems, so the RTLDL translator records the structural description portion of the RTLDL routines in the structure data tables. It divides the hardware parts of the RTLDL structural description and the structure data tables into two general categories, one being registers and memory, and the other being transfer units and switching units. These latter act as transient transmission paths in the digital system data transmission process, that is, as switches for use by data processing units. Their use is prescribed by function subroutines. Then, with the register and memory units, each time there is a register transfer this will elicit a change in their state, that is, each execution of a microinstruction will elicit a change in their state. Therefore, in the general simulation system we regard the registers and memory as the basis for hardware structure mapping, and use FORTRAN specification statements to define them as INTEGER variables or arrays. Their names and characteristic quantities are all recorded in the structure data table, and as long as the structure data table is searched, FORTRAN specification statements can be generated that correspond to the registers and memory. In addition, in microprogrammed digital systems, the

operation of hardware units is realized under control of microninstruction fields. In hardware unit function subroutines microninstruction fields appear as control variables (i.e., dummy units) for function subroutines, and therefore must define the microninstruction field names as integer variables in the specification statements of the simulation routines. The microninstruction field names and their characteristic quantities are clearly recorded in the microstructure data table, and by searching this microstructure data table and passing specification statements for microninstruction fields can be generated, which is the hardware mapping portion of Figure 2.

Only by combining the specification statement variables (hardware mapping) in the simulation routines with the simulation system command subroutines and hardware module function subroutines, can there be dynamic simulation of digital systems. The basic philosophy behind this implementation is based on a characteristic of routine modularization. Using a combination of both dummy and real, and establishing in the simulation routines call statements to the system command subroutines and call statements (or scheduling) to hardware central portion of Figure 2. It is automatically generated through mapping structure or the microninstruction format changes, all that needs to be done is to regenerate once. We explain a specific implementation method below through the use of an example.

Figure 3 is a flowchart of the ALU module, the RTLDL source code for which is as follows:

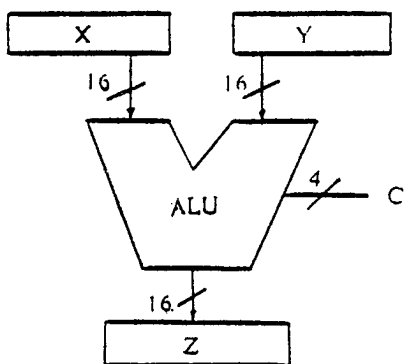

Figure 3. The Arithmetic and Logic Unit (ALU)

```

* RM X< 0: 15>;
* RM Y< 0: 15>;
* RM Z< 0: 15>;
ALU (X,Y: Z: C< 0: 3 >): =
  BEGIN
    DECODE C< 0: 3 >=>
      BEGIN
        0: = Z=X+Y, TERMINAT;
        1: = Z=Y-X, TERMINAT;
          :
        15: = Z=X, AND, Y;
      END
    END
  END

```

The structure data table as generated for this program by the RTLDL translator is shown in Figure 4, the data item ITYP in which being equal to 1 indicates registers and memory devices. Therefore, by looking for ITYP one can find the names of all registers and memories, as well as their word lengths (LWH2) and one-dimensional length (LWH1). When the word length is less than or equal to 16, it acts as an integer variable specification. Otherwise, it transforms to an array with declaration. And the control

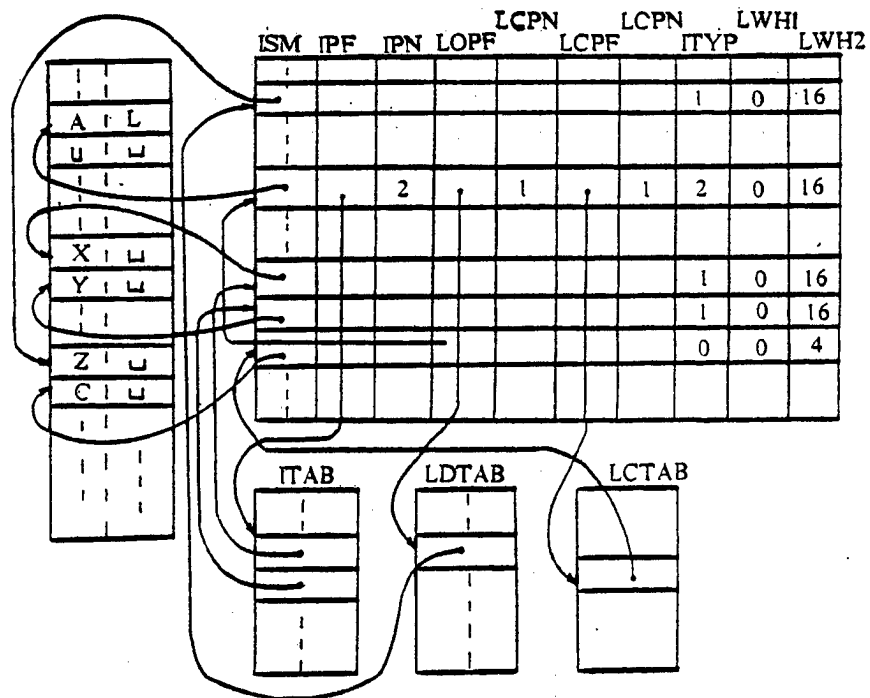

Figure 4. Structure of Data Table

System command subroutine call statements means those instructions that are related to register and memory variables, as for example when displaying and revising their contents the name of this kind of subroutine is determined, while each variable name and index values of the one-dimensional length and below act as real values in establishing a call statement. For example, in the example above, a call statement for a command subroutine corresponding to the display and revision of registers and memory would be:

```

0501      CALL OPENP (X,1,1,JQ,JR,1)
          GOTO 10
0502      CALL OPENP (Y,1,1,JQ,JR,2)
          GO TO
0503      CALL OPENP (Z,1,1,JQ,JR,3)
          GOTO 10

```

One can go on in this way to set up call statements for other system command subroutines.

By calling the OPENP subroutine, one can revise or initialize the values of the variables X, Y, and Z. This kind of command in the simulation system can change static values in a digital system. However, dynamic operations in a digital system are accomplished under control of the microprogram, and before a digital system begins dynamic operations it must call microinstruction interpretation routines:

In CALL INTERP (WCS, 0004, 0256, NEXA, 0064), WCS is the name of the control memory, 4 and 256 are one and two dimensional WCS lengths, NEXA is the control memory address, and 64 is the microfield length. One can obtain from this routine the microinstruction that has NEXA as its address and the values of the various fields, the expression format in the routine being:

$$C = \text{MCOD}(I)$$

where C is a predetermined field name, MCODE(N) is the array of field variables in memory N, and I indicates the ordinal field I of C.

Somewhat more complicated is setting up call statements for hardware module function subroutines, where one problem is in the horizontal microinstruction format, when a microinstruction includes several microcommands, but where within one microinstruction there is only one effective microcommand in a field. Therefore, the number of microcommands that can be executed within a microinstruction corresponds to the number of fields. However, within a microcycle, execution of a microcommand in each microinstruction has a fixed sequence. This sequence determines the sequence of function subroutine call statements, but that is connected with the microstructure. To resolve this problem, we reserved a field name input port in the generation routines for the user to enter the field names one by one based on the sequence in which each field is executed. In this way, he can set up corresponding subroutine call statements, the second problem is with the establishment of call statements, after field names have been input and the structure data tables are searched for data names. Using the example above, after the field name C has been input the structure table is checked (see Figure 4), which finds the data item LOPF for type C, and with LOPF the data item ISM as the name of the function subroutine. With that we can find the subroutine name ALU, and then with ALU data items IPF, IPN, LOPF, LOPN, LCPF, LCPN and their corresponding input variable, output variable, and control variable address tables ITAB, LOTAB, and LCTAB, we can then find these variable names. They are real elements of call statements, corresponding completely to subroutine dummy elements. The call statement we would get from the example above is:

```
CALL ALU (X, Y, Z, C)
```

Also, after each microinstruction executes, the trace table should be accessed to fill into the trace table the variable value that is recorded in the trace table, which makes for easier handling of trace routines.

What appear above are the basic principles and methodology behind our design of routines that automatically generate mapping of hardware structure and call statements, and by using them one can automatically generate GMSS portions that are directly related to hardware structure, which gives both a universality and a convenient structure to GMSS.

IV. CADSMDS Applications

We have used a simple modular CPU made up of Am2901's and an Am2010 as an example to show how to describe and simulate it using CADSMDS, the schematic for this machine appearing here as Figure 5. We constructed a 16 bit complement arithmetic data processor from Am2901's, the Am2010 is the sequential controller for the control memory WCS (i.e., the lower address generating circuit), the Am2922 is controlled by the microninstruction conditional test field TSCND, and it selects processor state conditions and generates control condition CC for the Am2910. The multiplex switch MUXD is used in selection of input data for the Am2910. Please see documents^{4,5} for relevant device functions and structures. There is a controlling signal on either side of each hardware module block in Figure 5, which correspond to microninstruction fields, and above and below these are input/output signals. The microninstruction format for this model computer are defined in Figure 6.

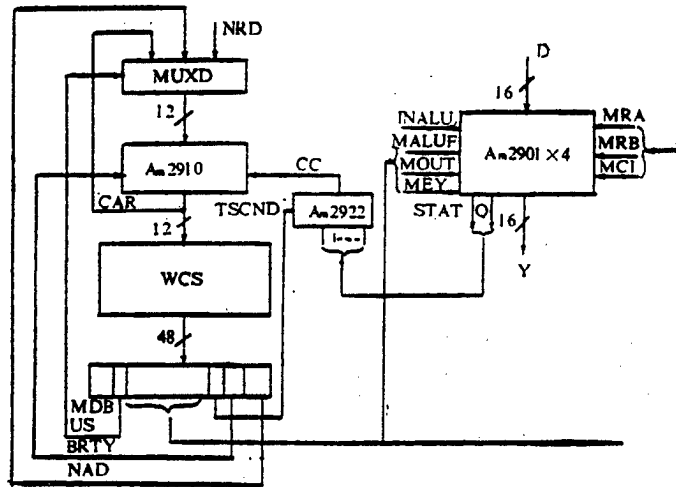

Figure 5. CPU Block Diagram of a Model Computer

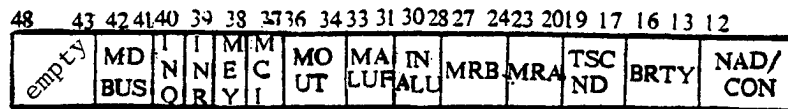

Figure 6. Microinstruction Format for a Model Computer

We have simulated and tested the basic functions of the model computer on the CADSMDS system, but only show the simulation process for a 16-bit integer multiplication microprogram as an example. The microassembler program for this program is shown in Figure 7. If the CADSMDS system for this system had already been provided, then the name of the source program in Figure 7 would first be the input of the microassembler translator program, by which could then be generated the corresponding micro object code file. Then recall the GMSS, the input for which is the name of this object file. It loads the micro object program into the controller memory WCS, after which

the simulation system begins its interactive state. Using the system commands, it then places the multiplier and the operand into registers Q and RAM1, respectively, before initializing the microprogram with the initializing command. The two numbers in registers Q and RAM1 are multiplied in the arithmetic unit Am2901 under control of the microprogram. The lower 16 bits of the product are in Q and the higher 16 bits are in RAM2, the specific process for which, please see Appendix 1. We provide in Appendix 2 a portion of source code and the hardware mapping and scheduling routines thus produced for reference.

```
* NAME MUL
* LOC 100
RB2 RSOB AND FBFY INC; ! R2 = 0
MNAD CLDCT 15
LOOP: MNAD QO CJS (MJP);
      RA1 RB2 RSAB ADD FBFY INC;
MJP:  RA2 RB2 RSAB OR SRFQ MNAD RPCT (LOOP);
      JZ;
* END
```

Figure 7. Microprogram for Integer Multiplication

V. Conclusions

We feel that with the development of LSI circuits research into exploiting register transfer level design automation for digital systems is very significant for both digital systems structure design and for teaching. Our work in these areas has been limited. This article briefly described the basic design theory and methodology of CADSMDS, a computer-aided design system for microprogrammed digital systems, as well as basic results that have been achieved. Due to limitations in our expertise, experience, and working conditions, if there are inaccuracies, please convey them to the author.

REFERENCES

1. Li Minghui, "GMC GS, a General Purpose Microcode Generation System," XIAOXING WEIXING JISUANJI XITONG [MINI-MICRO SYSTEMS], 1983.2.
2. Li Minghui, "The Definition of RTL DL, a Register Transfer Level Hardware Description Language, and its Translator," Proceedings of the Third National DA Conference, 1984.10.
3. Li Minghui, "Design and Implementation of a PDP-11/60 Microprogram Level Simulator," ZHONG XIAO XING JISUANJI [MEDIUM-, SMALL-SIZE COMPUTERS], 1981.4.

4. Meyers, G.J., "Digital System Design With LSI Bit-Slice Logic."
5. Li Minghui, "Microprogramming," Dalian Institute of Technology lectures.

Appendix 1. Execution Process of Multiplication Method in the Simulator

PLEASE INPUT FILE NAME OF GLOBAL TABLE

CC	1	0	1
DB	4	0	4
STAT	7	0	0
DBUS	12	0	12
STACK	17	5	12
CAR	23	0	12
Q	27	0	4
Y	29	0	4
CNTR	31	0	12
RAM	36	16	4
NEXA	40	0	12
WCS	45	256	64
STP	49	0	4

PLEASE INPUT FILE NAME OF MICROCODE

00000000	00000111	00011001	00000000	11100000	00000000	100
00000001	00000000	00000000	00000000	11000000	00001111	101
00000001	00000000	00000000	00000110	00010000	01101000	102
00000000	00000110	00001001	00001000	11100000	00000000	103
00000001	00001000	11001001	00010000	10010000	01100110	104
00000000	00000000	00000000	00000000	00000000	00000000	105

INPUT COMMAND

Q (1, 1) = 21644

Q (1, 1) = 32

INPUT COMMAND

RAM (1, 1) = 31426

RAM (1, 1) = 32

INPUT COMMAND

INPUT COMMAND

Q (1, 1) = 1024

INPUT COMMAND

RAM (1, 1) = 32

RAM (1, 1) = -11

INPUT COMMAND

INPUT COMMAND

Q (1, 1) = -11264

INPUT COMMAND

Note: $32 \times 32 = 1024$

Note: $1024 \times (-11) = -11264$

Appendix 2. Hardware Mapping and Scheduling Routines of the Simulator

```

SUBROUTINE SSIM
INTEGER CC, DB, STAT, DBUS, STACK (0005), CAR, W,Y, CNTR, RAM(0016),NEXA
* , WCS (0004, 0256), STP
INTEGER CON, NAD, BRTY, TSCND, MRA, MRB, INALU, MAKUF, MOUT, MCI,
* MEY, INR, INQ, MDBUS
COMMON /TR/NS(10), NA(10), NB(10), NV(10)/MC/MCOD(50)
CALL LOADM (WCS, 0004, 0256)
NEXA = 0
10 CALL DIAL (JC, IP, IQ, IR)
IF (JC.NE.79) GOTO 1
GOTO (0501, 0502, 0503, 0504, 0505, 0506, 0507, 0508, 0509, 0510, 0511, 0512, 0513), IP
0501 CALL OPENP (CC, 0001, 0001, IQ, IR, 0001)
GOTO 10
0502 CALL OPENP (DB, 0001, 0001, IQ, IR, 0002)
GOTO 10
0503 CALL OPENP (STAT, 0001, 0001, IQ, IR, 0003)
GOTO 10
0504 CALL OPENP (DBUS, 0001, 0001, IQ, IR, 0004)
GOTO 10
0505 CALL OPENP (STACK, 0001, 0005, IQ, IR, 0005)
GOTO 10
0506 CALL OPENP (CAR, 0001, 0001, IQ, IR, 0006)
GOTO 10
0507 CALL OPENP (Q, 0001, 0001, IQ, IR, 0007)
GOTO 10
0508 CALL OPENP (Y, 0001, 0001, IQ, IR, 0008)
GOTO 10
0509 CALL OPENP (CNTR, 0001, 0001, IQ, IR, 0009)
GOTO 10
0510 CALL OPENP (RAM, 0001, 0016, IQ, IR, 0010)
GOTO 10
0511 CALL OPENP (NEXA, 0001, 0001, IQ, IR, 0011)
GOTO 10
0512 CALL OPENP (WCS, 0004, 0256, IQ, IR, 0012)
GOTO 10
0513 CALLOPENP (STP, 0001, 0001, IQ, IR, 0013)
GOTO 10
1 IF (JC.NE.71.AND.JC.NE.83) GOTO 10
IF (NEXA.NE.0) GOTO 3
NEXA = IQ
3 KR = 1
99 CALL INTERP (WCS, 0004, 0256, NEXA, 0064)
CON = MCOD (0001)

```

```

NAD = MCOD (0002)
BRTY = MCOD (0003)
TSCND = MCOD (0004)
MRA = MCOD (0005)
MRB = MCOD (0006)
INALU = MCOD (0007)
MALUF = MCOD (0008)
MOUT = MCOD (0009)
MCI = MCOD (0010)
MEY = MCOD (0011)
INR = MCOD (0012)
INQ = MCOD (0013)
MDBUS = MCOD (0014)
CALL A2901 (DB, Y, Q, RAM, MRA, MRB, INALU, MALUF, MOUT, MEY)
CALL A2922 (Q, STAT, CC, TSCND)
CALL MUXD (CAR, NAD, NRD, DBUS, MDBUS)
CALL A2910 (DBUS, NEXA, CNTR, STACK, STP, CAR, BRTY, CC)
DO 201 K = 1, 10
IF (NS(K).EQ. - 1) GOTO 201
L = NS(K)
KA = NA(K)
KB = NB(K)
GOTO (0701, 0702, 0703, 0704, 0705, 0706, 0707, 0708, 0709, 0710, 0711, 0712, 0713), L
0701 NV(K) = CC
      GOTO 201
0702 NV(K) = DB
      GOTO 201
0703 NV(K) = STAT
      GOTO 201
0704 NV(K) = DBUS
      GOTO 201
0705 NV(K) = STACK(KA)
      GOTO 201
0706 NV(K) = CAR
      GOTO 201
0707 NV(K) = Q
      GOTO 201
0708 NV(K) = Y
      GOTO 201
0709 NV(K) = CNTR
      GOTO 201
0710 NV(K) = RAM(KA)
      GOTO 201
0711 NV(K) = NEXA
      GOTO 201

```

```
0712  NV(K) = WCS(KB,KA)
      GOTO 201
0713  NV(K) = STP
      GOTO 201
201   CONTINUE
      KR = KR + 1
      CALL TRACE(KR)
      CALL BREAK(NEXA, IT)
      IF(IT, EQ. 1) GOTO 10
      IF(NEXA, NE. 0, AND. JC, EQ. 71) GOTO 99
      IF(NEXA, NE. 0) GOTO 10
      RETURN
      END
```

12586/9365
CSO: 4008/1068

APPLIED SCIENCES

FAULT DIAGNOSTIC TECHNIQUES, DIAGNOSTIC INSTRUMENT

Shenyang XIAOXING WEIXING JISUANJI XITONG [MINI-MICRO SYSTEMS] in Chinese
No 5, 8 May 85 pp 28-35, 6

[Article by Qian Xianggen [6929 4382 2704] and Zhu Aiping [2612 1947 1627]: "A New Technique for Fault Diagnosis in Microcomputer Systems*": The Dynamic Simulation--Signature Analysis Technique]**]

[Text] Abstract: A new method is presented for use in fault diagnosis in microcomputer systems--the dynamic simulation method. This method is simple and easy to implement. This method is combined with the "signature analysis" method to realize registration of microcomputer system faults. Also introduced is a unique method used for checking information flow through circuit nodes, and a "hypothetical model for measured microcomputer information flow" and a method of calculation for fault trace registration are discussed. These techniques were used to develop a "portable tool for microcomputer system diagnosis," which is available for use.

I. Introduction

When a digital system is in operation, if the system exhibits capabilities that are not the same as its design provisions, this can lead to mistaken results, and people then say that the system is faulty. One must then test to discover the fault. Normally, there are two kinds of testing: one kind simply distinguishes between good and bad, which is called "detection." The other kind of test is called "diagnosis," which not only provides a determinate response regarding whether or not there are faults in the circuit, but goes further by determining the position of the faults. Obviously, the level of difficulty for the latter is much greater than that of the former.

Early digital systems relied chiefly upon manual fault searching, which made for a great dependence on the skill levels and experience of people in the profession. With the expansion in scale and increase of complexity of digital systems, manual diagnosis has gradually been replaced by machine diagnosis, which has given rise to diagnostic theory.

*By "fault," in this paper we refer to hardware faults.

**Xu Suluan [1776 4790 7762], Li Yan [2621 3508], and Zhong Yuechun [6988 1471 2504] all participated in this research.

To implement machine diagnosis we must first establish logical fault models. Actual practice has shown that the following logical fault models can be successful:

permanent faults (hardware faults)	fixed faults (stick-at-zero, stick-at-one) diode shorting faults in-line bridge faults pattern sensitive faults in RAM
intermittent faults (software faults)	these are largely caused by critical timing, noise, tolerances too close, and aging, and will only appear as fault characteristics under certain conditions. However, many faults among them will eventually become hardware faults.

Currently, fault diagnostic techniques for combinational logic circuits are rather mature. There are already channel sensitizing, the Boolean difference method, the star algorithm, and the D algorithm that can be used in actual diagnosis. What these methods study and resolve are the first three types of faults among the permanent faults above. Compared with combinational circuits, diagnostic theory and methods for sequential circuits are still immature.

The appearance of LSI, of which microprocessors are an example, has definitely brought with it many advantages, but it has also brought new and enormous difficulties for the fault analysis of digital systems. This is because on the one hand circuit structures for LSI and systems composed of LSI are so complicated and their fault modes are not easy to establish. On the other hand, there are a limited number of LSI leads, which greatly reduces the controllability and observability of faults. As for microcomputers composed of LSI, we can generally only test their checking capabilities to a certain degree. If we wanted to carry out complete logical testing, that just cannot be done with current technology. As Bitton¹ points out, complete testing of a microprocessor chip would require 10^{78} years. if we were to suitably check the question of pattern sensitivity, it would take 10^{23000} years.

Currently, and aside from a small number of companies that manufacture microcomputer systems in large quantities using complicated and expensive specialized advanced testing systems (for different measured systems or printed circuit boards different specialized hardware interfaces and support software must be designed) to diagnose faults, many manufacturing plants and companies, and users, make use of various function modules of self-checking programmed testing systems, so fault registration still relies upon manual inspection.

This paper discusses the theories of dynamic simulation techniques and signature analysis techniques, as well as a method for integrating the two to implement microcomputer system fault diagnosis. This paper also discusses the "hypothetical model for measured microcomputer information flow" that we have proposed, and a unique testing method for circuit node information flow--two different directions (indicating the direction toward the CPU and its

opposite) testing circuit node information flow, and fault tracing and registration algorithms that derive from this. As an example, we have also introduced a new instrument: a portable general use instrument for microcomputer system fault analysis. The cost of this instrument is twice that of ordinary single board computers, and it can itself be used as an ordinary computer. This instrument can be used to set up signature dictionaries and fault diagnostic techniques for measured microcomputer systems, and then go on to guide maintenance and debugging personnel to fault tracing and registration of the measured system. In the early stages of microcomputer system development, this instrument can be used as a simple simulator for hardware development, consequently allowing developers to escape the difficulty to debug and test system hardware prior to the production of monitor and other software.

II. Dynamic Simulation Diagnosis Techniques for Microprocessor Systems

As we said above, when investigating microcomputer system faults, self-checking is usually an effective method. However, there are two deficiencies when self-checking methods do fault checking on microcomputer systems. First, when there is a fault in the system "internal check" (see Figure 1) that leads to system paralysis, the self-check routines completely lose their effectiveness. Secondly, self-checking methods have difficulties in implementing fault registration. The dynamic simulation method can test for faults, whether the measured system "internal check" is right or not, and can combine as well with signature techniques to implement fault registration.

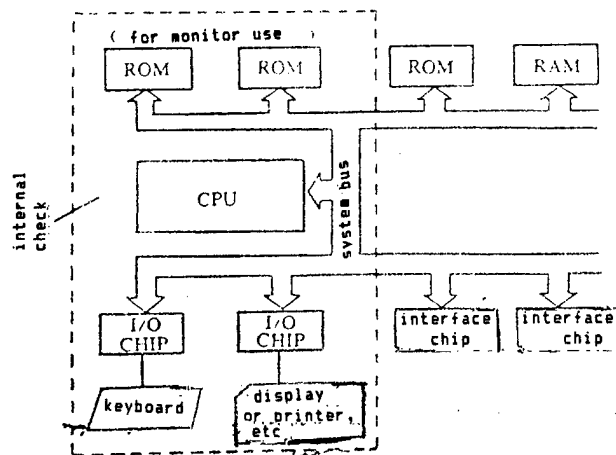

Figure 1. The Basic Structure of Microprocessor Systems

We first explain the principles of dynamic simulation techniques as follows:

We can divide any microcomputer system hardware into two parts, the CPU and non-CPU. [In this paper microcomputer systems are assumed to have single CPU's] Among those, the non-CPU portion includes all parts other than the CPU. Obviously, any fault in a microcomputer system can be summed up as

being in either one or both of the parts mentioned above. Then, to get rid of faults, all one needs to do is separately diagnose the measured system CPU chip and non-CPU parts. Take the CPU chip from the CPU socket in the measured system for testing by itself, or replace the original CPU with one you know is all right, by which you can solve problems in the diagnosis of the measured CPU. Elimination of faults in the non-CPU portion is much more complicated. That is because they are composed of ROM, RAM, buffers, I/O interface chips, as well as various control logic circuits, and therefore the sources of faults are difficult to find. We take the CPU of the measured microcomputer system out of its socket, and then connect this socket and another computer, COMPU, together (it can be another single board computer), then we can run the dynamic simulation program on the other computer for dynamically simulated fault diagnosis of the measured system. For measured systems where the CPU is soldered to the printed circuit board, we can set the three state logic pins of this CPU chip to a state of high resistance, while electrically cutting off the few remaining pins from the circuit (we can remove the preset jumpers). Then we can clamp a multipin clamp to the CPU chip leads to electrically connect COMPU and the measured system.

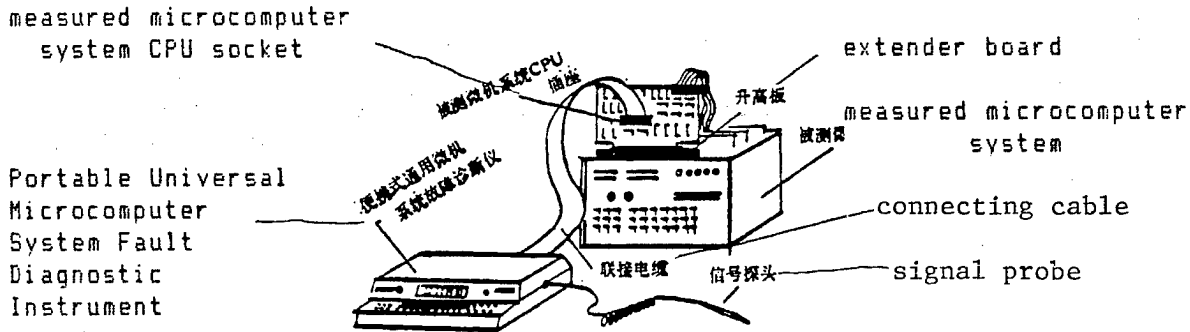

Figure 2. Connecting the Test Instrument to the Measured Micro-computer System When Dynamically Simulating Faults

The functions of the dynamic simulation programs simulate the various operations in the CPU to control the non-CPU part of the measured system, as well as to effect exchange of information between them. As long as you write various dynamic simulation routines, you can inspect the non-CPU part of the measured system as it carries out various operations (like, reading ROM, writing and reading RAM, keyboard scanning, writing to display, etc.) to see whether it produces a fault.

We have developed a dynamic simulation algorithm suitable for microcomputer systems with 8080 CPU's, and are providing the developed simulation software package with the portable microcomputer system fault diagnosis instrument.

We can provide a corresponding dynamic simulation software package for other model CPU's to make dynamic simulation diagnosis easier for the corresponding microcomputer systems.

Dynamic simulation techniques offer complete control of the non-CPU part of the measured system. This feature allows single beat mode of operation for the measured system (similar to that on minicomputers). We can use this function to make the measured system execute step by step various operations as determined by the relevant instructions, which conveniently checks various devices in the system and circuit functions and states to see if they are correct. When developing hardware for microcomputer systems or examining and repairing faults, one can first run the dynamic simulation routines to seek out faulty modules, then, single step through the smaller number of instructions to find the fault.

III. Signature Techniques

This is a data compression technique based on CRC principles. The signature concept was formed during repair of faulty digital systems.

People have done much research on the various characteristics of using PRBSG's (pseudo random binary sequence generator) implemented with linear feedback shift registers, and have come up with several beneficial results. One of the characteristics of PRBSG's that have drawn people's attention is the repeatability of its generation of PRBS, that is, it is a characteristic in which PRBS periodically appear in the PRBSG output sequences. We know that any linear feedback shift register corresponds to a characteristic polynomial. The longest nonrepeating series produced by an n order linear shift (i.e., the longest duration) is $2^n - 1$. At that time, the characteristic polynomial for that linear feedback shift register is certain to be the primitive polynomial.²

Figure 3 has an example of a PRBSG formed by a fourth order feedback shift register. The characteristic polynomial for this PRBSG is $X^4 + X^3 + 1$ (this is a primitive polynomial; the feedback polynomial is $X^4 + X + 1$). The length of the nonrepeating series produced by this PRBSG is $2^4 - 1$. Adding a binary data flow in peripheral output mode to the PRBSG, we can then link up the binary number series to the peripheral data flow (see Figure 4). This peripheral data flow disturbs the internal series of the PRBSG, producing a new binary number series.

After passing a binary data flow D of m bits through an m beat clock into a PRBSG, the remainder in the PRBSG is called the signature of D in the PRBSG. Now, to analyze the properties of the signature:

Let L be an n order linear feedback shift register with a longest duration of $2^n - 1$, then its characteristic polynomial is $F(X)$. Let X, Y be two random binary data flows of m bits, and $R(Y)$ and $R(Z)$, respectively, be the signatures when in L . Actually, $R(Y)$ and $R(Z)$, respectively, are the remainders obtained after dividing Y and Z by $F(X)$. It can be shown³ that when $R(Y) = R(Z)$, the probability of $Y = Z$ is

$$\text{Probability} = 1 - \frac{2^{m-n} - 1}{2^m - 1}$$

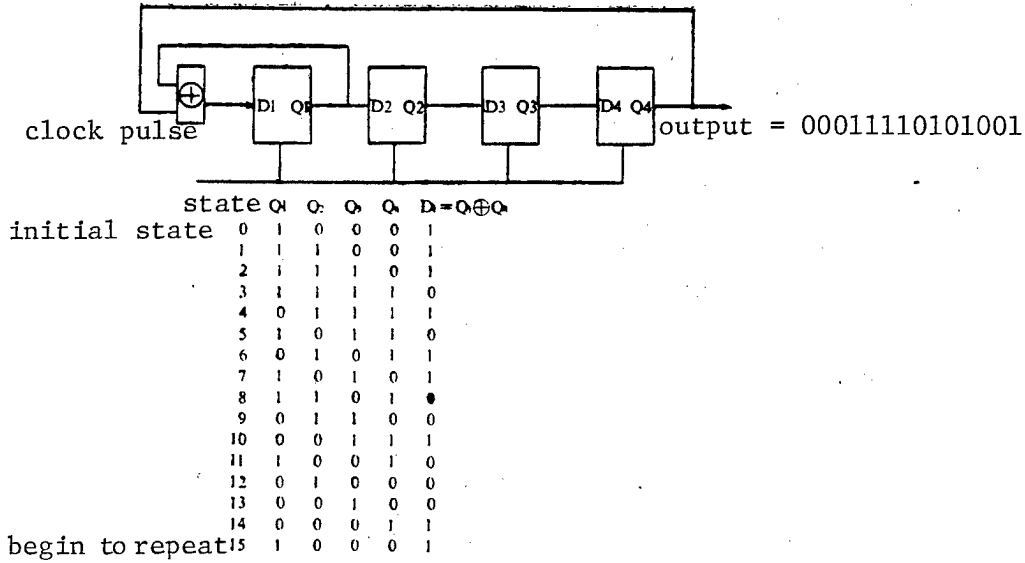

Figure 3. A PRBSG Composed of a Fourth Order Feedback Shift Register

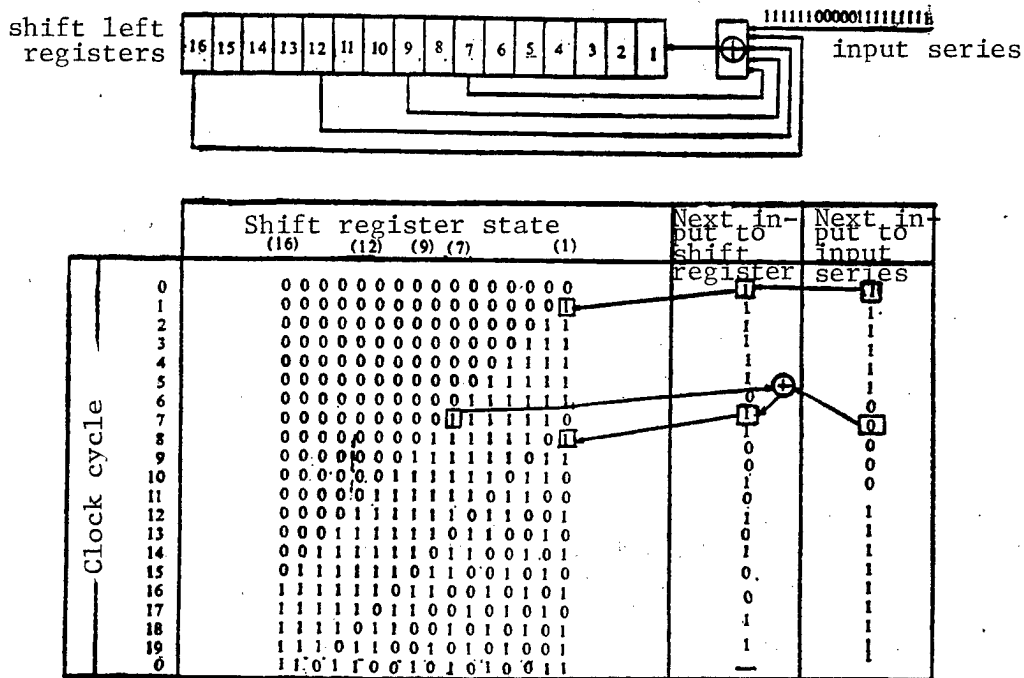

Figure 4. Chaining Peripheral Data Flow to a PRBS

When $m \gg n$, for example, when $m = 100$ and $n = 16$,

Probability $\approx 1 - 1/2^n \approx 99.998$ percent, that is the accuracy of using the signature to distinguish data flows is very high, and also, the probability of two different data flows having the same signature is very slight. This

property can be used in fault diagnosis of digital systems. We can first test for the signatures of several circuit nodes in a microcomputer system when operations are normal, establishing a signature dictionary. When this system experiences problems, if the signature of a node is different from its normal value, then it can be determined that the information flow through this node is abnormal. Of course, this certainly does not signify that there is a fault at this node. To find the location of the true fault, fault tracing and registration must be undertaken through previously designed fault diagnostic tree and previously tested signature dictionary.

IV. Principles and Composition of the PUFDI

The PUFDI (Portable Universal Microcomputer System Fault Diagnostic Instrument) is made up of two parts, the dynamic simulator and the signature analyzer. The former includes a microcomputer and interface circuits for the microcomputer systems to be measured. PUFDI is supported through a dynamic simulation package. In it, there are several simulation routines. The user can use these simulation routines to conveniently develop hardware or do dynamic simulation diagnosis of the measured microcomputer system.

For example, if you want to do a write, read data or check on the RAM cells of a system from the address abcd to the address efgh, you need only to run the following algorithm process on the dynamic simulator:

```
Procedure TESTRAM
  DATA ← qr
  for I = abcd to efgh do:
    call subroutine WRAM
  next I
  for I = abcd to efgh do:
    call subroutine RRAM
    if DATA ≠ qr then EXIT
  next I
end (of TESTRAM)
```

Therein, a,b,c,d,e,f,g,h,q, and r are all hexadecimal data; the function of the dynamic simulation subroutine WRAM is to write the contents of DATA into the I cell of the internal memory of the measured system. The function of the dynamic simulation subroutine RRAM is to read the contents of the I cell in system memory into DATA.

To test for the signature, the dynamic simulation software package provides a "time window" control signal and many necessary clock signals for the signature analyzer. These clock signals are used by the signature analyzer as CP pulses for the linear feedback shift register. Figure 5 shows the wave forms of the time window, the clock, and the measured signal, as well as the binary data flow collected (acting as peripheral input to the linear feedback shift register).

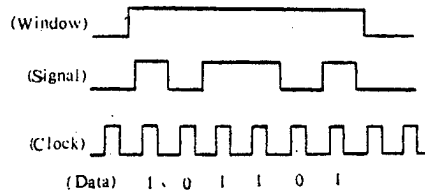

Figure 5. Signal Waveform Chart

We can see from Figure 5 that the signature tested from any circuit node opens a timed interval in the "time window" (a window is level 1), and then the signature of the binary data flow is sampled using the CLOCK signal.

See Figure 6 for the key diagram of the signature analyzer. In that, PRBSG is formed by a 16th order linear feedback shift register with a characteristic polynomial of $X^{16} + X^{12} + X^9 + X^7 + 1$. The feedback polynomial is $X^{16} + X^9 + X^7 + X^4 + 1$. This is the longest PRBS generator for a feedback bit interval to be uneven. To make the binary data series whose signatures are mistaken as far apart as possible, and also to take into consideration whether the microcomputer normally uses repeated patterns of four or eight bits when doing its checking, it then selects a linear feedback shift register from among the 2048 16th order linear shift registers that will possibly generate the longest PRBSG.

In Figure 6, the function of the unstable lamp is to indicate when there is an unstable operations fault at the measured circuit node.

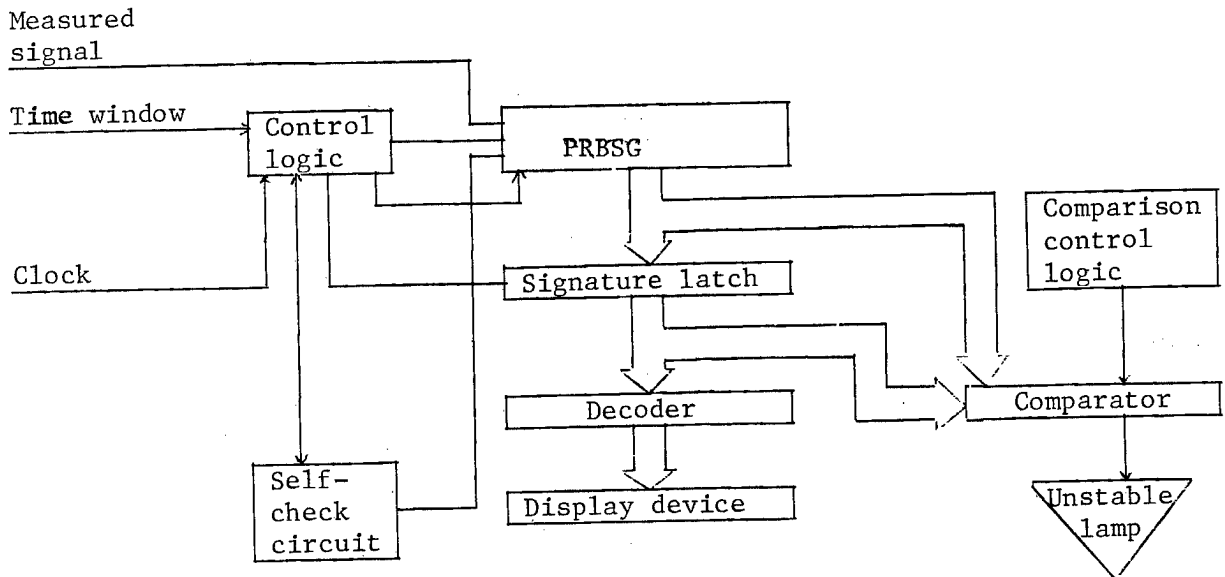

Figure 6. Key Diagram for the Signature Analyzer

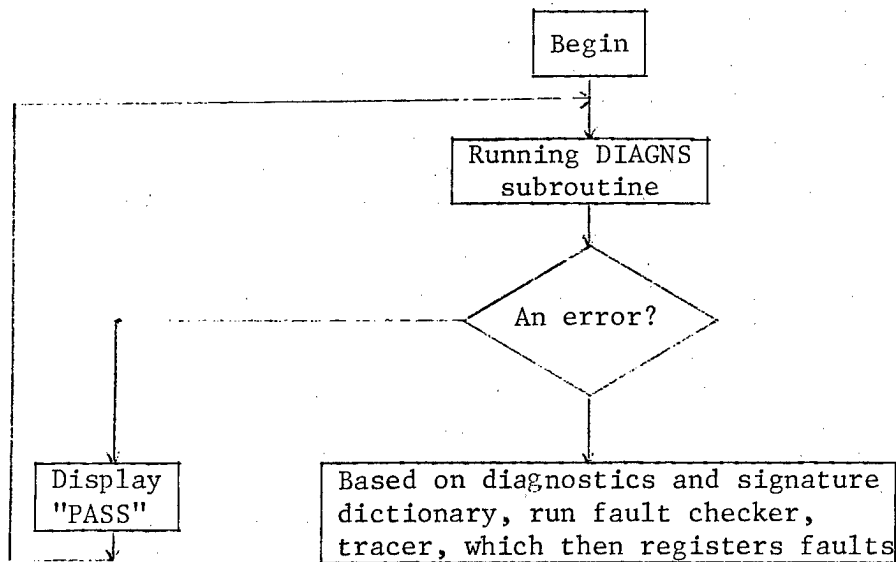

Figure 7. Flowchart for Diagnosing Faults on a Microcomputer System

In the figure, the structure of the diagnosis routine is as follows:

```

Procedure      DIAGNS
  repeat:      {call subroutine OPENWINDOW;
                {call procedure TEST
                {call subroutine CLOSEWINDOW

end      (of DIAGNS)
  
```

Here, procedure TEST is an algorithm procedure that uses dynamic simulation routines written to diagnose faults on the measured system. In the dynamic simulation subroutine we have already set up the necessary clock generation commands to test for the signature. This does not then need to be considered again when writing the algorithm procedures for dynamic simulation diagnosis.

The algorithm procedure DIAGNS runs in the endless loop mode, and is consequently able to repeatedly test any circuit node for the signature each time the time window is open.

All one needs to do to set up a signature dictionary for measured systems is to connect the PUFDI and the measured system during normal operation and run dynamic simulation diagnosis routines, and then gather several signatures from appropriate circuit nodes and record them.

Before discussing fault tracing algorithms, we first introduce the following two terms:

Input Data Flow--the data flow through any circuit node in a microcomputer system, where when the direction of this flow is into the CPU, this data flow is called the input data flow, or IDF for short.

Output Data Flow--a non-input data flow at any circuit node in a microcomputer system is called output data flow, or ODF for short. Obviously, the flow direction of ODF's in the majority of circuit nodes is going to be out of the CPU. As for those ODF's at circuit nodes with little relation to the CPU, we have determined that their flow direction is the actual flow direction of the data flow.

When doing fault testing by running self-testing routines on microcomputer systems, component or line faults in the system will not only affect the accurate execution of certain instructions themselves, but could also affect the instruction series. The average self-test program must execute tens of thousands of instructions, so we do not currently use self-testing routines as fault registration algorithms. On this point, the fault diagnosis method that we used combining dynamic simulation with signature analysis techniques has an obvious superiority. When we were designing the dynamic simulation routines, we resolved the following two points: (a) when dynamic simulation routines are running, program flow is not affected by the measured system. (b) We can use the signature analyzer to separately test for ODF and IDF in all circuit nodes in the measured system. This way, when we are using PUFDI for fault diagnosis on a particular module in the measured system, if that module has a fault to the extent that it leads to an abnormal ODF on certain circuit nodes, then this will naturally lead to a corresponding abnormal IDF between the ODF and certain circuit nodes on the IDF path of this module. However, the converse is not true. This characteristic allowed us to be able to develop the "fault tracing and registration algorithm."

To make it easier to describe the "fault tracing and registration algorithm," (also, the "fault diagnostic technique and signature dictionary generation algorithm"), we will first set up a measured microcomputer system data flow model as follows:

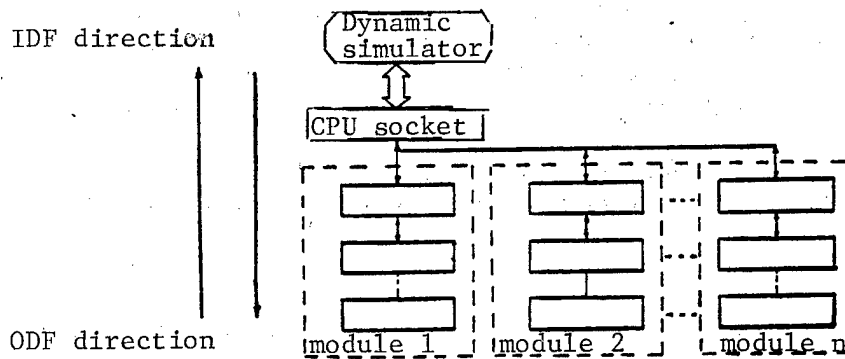

Figure 8. Hypothetical Model for Data Flow of Measured Computer System

In the figure, each solid line rectangle represents circuit components, each of which has two terminals. When running a certain dynamic simulation diagnostic routine P on a dynamic simulator, and testing a measured system without faults, the IDF and ODF are determined as they flow through any two

terminals of component E in the measured system (actually, what we mean by IDF and ODF here is the IDF and ODF when the time window in the diagnostic program is opened). We use f_{II}^E and f_{IO}^E , respectively, to represent the IDF flowing into and out of component E at this time; we use f_{OI}^E and f_{OO}^E , respectively, to represent the ODF.

When using the same routine P to retest the measured system above (or when testing another system of identical model), we add an asterisk to the upper left of the symbols above to represent the corresponding data flow through component E at this time. We have, then, the following standard of identification:

- (a) $*f_{IO}^E \neq f_{OO}^E$, if and only if $*f_{OI}^E \neq f_{IO}^E$, where component damage V is a short at node B in component E (see Figure 9).
- (b) $*f_{IO}^E \neq f_{IO}^E$, if and only if: $*f_{OI}^E \neq f_{IO}^E$ \vee $*f_{II}^E \neq f_{II}^E$, where component E's damage V is a short at node A of component E (see Figure 9).

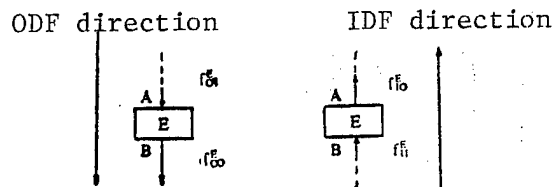

Figure 9.

Based on the standard of identification above, the "algorithm for fault tracing and registration" obtained is shown in Figure 10:

1. Begin
2. Use the determination routines in the dynamic simulation program to check all module functions in the system
3. Normal? — Exit if not
4. Select a component E in the faulty module
9. Beginning with component E, find another component E' next to and connected to E in the direction of ODF
16. Starting from E and going in the direction of the IDF, find a component E'' that is connected next to E

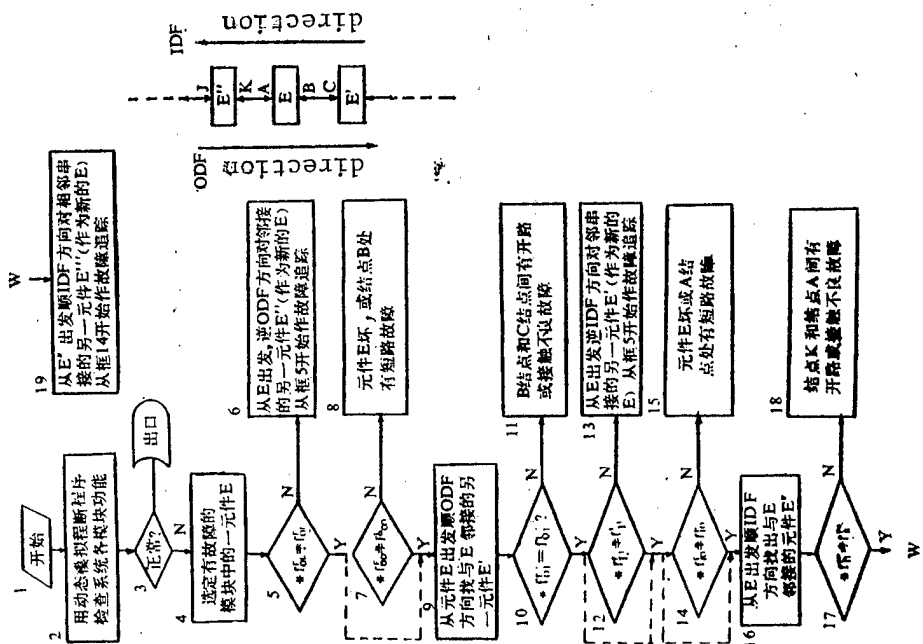

Figure 10. Algorithm for Fault Tracing and Registration

Note 1. The dotted lines with arrows in the flowchart represent: the execution flowchart when the operation in diamond block next to it is not necessary (for example, when a particular component has no OIF flow there is no need for block 7)

Note 2: The execution of blocks 5,7,10,12,14, and 17 is realized through checking the signature of the corresponding node.

19. Trace faults beginning with flowchart block 14 for another component E''', connected serially in a direction against the IDF, beginning with E
6. Beginning with E, trace faults beginning with block 5 on another component E'' next to the original (make it a new E) that is against the ODF direction
8. Component E is bad or there is a fault short at node B
11. Between nodes B and C there is a fault due to an open circuit or a poor contact
13. Trace faults beginning with flowchart block 5 for another component E' connected serially in a direction against the IDF, beginning with E
15. Component E is bad or node A has a short
18. Between node K and node A there is an open circuit or a poor circuit.

We have already expanded application of the algorithm above to actual microcomputer systems. Because of the length of our paper, we will not describe it further.

VI. Conclusion

This paper has discussed the principles and methodology of implementing microcomputer system fault diagnostics through a combination of dynamic simulation techniques and signature analysis techniques. Currently domestic and foreign microcomputer systems are developing enormously. In comparison with this, the development of microcomputer system fault diagnostic techniques and tools has been slower. Looking at this from our domestic situation, it is even more true. The PUFDI that we have discussed in this paper can be used for microcomputer system development and production, and for use by units as a tool for debugging, production, and maintenance. Now that we can use the PUFDI to write fault diagnostics and signature dictionaries for a particular microcomputer applications system, then, be it production factory or agent, or the user, the PUFDI has many advantages.

We used the PUFDI to make practical tests on a microcomputer applications system with an 8080 CPU. Dealing first with the hardware development stage of this system (the monitor, etc., had not been developed), we checked the hardware parts of the measured system using PUFDI, even eliminating a fault due to a damaged RAM chip, using the single step operation. Then, when the system was working normally we set up fault diagnostics and a signature dictionary, before asking the system designers to establish several permanent faults, after which we did fault tracing and registration operations strictly following the fault diagnostics and signature dictionary. The results were that each fault was accurately registered within a few minutes. This has preliminarily shown that the methods described in this paper will work.

Of course, because the dynamic simulation techniques that we use at present are implemented based upon a single board computer simulating the CPU of the measured system, that means that under dynamic simulation the operational speed of the measured system decreases. However, as Teradyne⁴ and Chen,⁵ et al. point out, the majority of faults in logic components in a microcomputer system will appear in a static state, and what is more, many intermittent faults will finally become permanent faults. Therefore, PUFDI is no less an effective tool for microcomputer system fault diagnosis.

Obviously, the techniques discussed in this paper are completely suitable in plans for dynamic simulators in fast computers, too. In this situation, one can do high speed dynamic simulation and fault diagnosis of measured microcomputer systems.

This research work has received the guidance and help of the Institute's senior engineers Shi Shiping [0670 0013 1627] and Zhu Shengyu [2612 5116 3768], and engineers Wei Weixiao [1414 4850 1321], Shou Fuming [1108 4395 2494], and Yu Jianhua [0151 1696 5478]. Professor Xie Xiren [6200 1585 0088] of the Academy of Communications Engineering read this paper, for which I also express my appreciation.

REFERENCES

1. Bitton, J.M., "A Survey of Self-Test and BITE Program Generation," EUROMICRO JOURNAL, 6 (1980) 168-174.
2. Lin Kexiang [2651 0668 4382] and Wang Yifei [3076 0001 7378], "The Theory and Application of Pseudo-random Codes," People's Posts and Telecommunications Publishing House, 1978.12, 1st edition.
3. Fronwerk, Robert A., "Signature Analysis. A New Digital Field Service Method," HP JOURNAL, May 1977.
4. Teradyne, Peter Hansen, "A Test Strategy for Microprocessor-Based LSI Boards," 1978, Semi. Test Conf.
5. Chen Tinghuai [7115 1694 2849] and Chen Guangxi [7115 0342 3556], "Diagnosis and Fault Tolerance in Digital Systems," National Defense Industry Publishing House, 1981.6, 1st edition.
6. Robach, C., Saucier, G., and Aleonard, C., "Microprocessor Systems Testing--A Review and Future Prospects," EUROMICRO JOURNAL, 5 (1979).
7. West, David G., "In-Circuit Emulation and Signature Analysis: Vehicles for Testing Microprocessor-Based Products," 1979, IEEE Test Conference.
8. Taschioglou, Kemon P., "An Overview of LSI Board Testing Today," 1978 Semi. Test Conf.
9. Coffron, James W., "Understanding and Trouble shooting the Micro-processor," 1980, by Prentice-Hall, Inc., Englewood Cliffs, N.J.
10. Buckroyd, Allen, "Production Testing of Microprocessor-Based Equipment," MICROPROCESSORS AND MICROSYSTEMS, Vol 5 No 7, September 1981.
11. Gordon, Gary and Nadig, Idans, "Hexadecimal Signatures Identify Troubleshoots in Microprocessor Systems" ELECTRONICS, 3 March 1977.

12586/9365
CSO: 4008/1067

MICROCOMPUTER APPLICATIONS IN HEAT TREATMENT FIELD

Beijing JINSHU RECHULI [HEAT TREATMENT OF METALS] in Chinese No 10, Oct 85
pp 3-9

[English abstract of article by Yan Chengpei [7051 2110 3099] of Beijing Electromechanical Institute, Ministry of Machine Building Industry]

[Text] A brief history of the development and major applications of micro-computers in the field of heat treatment is given. By means of a number of typical cases in China and abroad, the application and development of microcomputers are described. Included are computer-aided design (CAD) for calculations, data processing and predicting properties after heat treatment, controlling and monitoring of the heat treatment processes, the study of mathematical models, microcomputer-assisted calculations and management in the process of heat treatment, multiple controlled microcomputer systems and microcomputer digital simulation technology. Lastly, the application prospects and the current development of the microcomputer in the heat treatment field are discussed.

REFERENCES

- [1] 微电脑在热处理中应用概况, 上海交通大学内
部资料。
- [2] 《国外金属热处理》, 1984.6。
- [3] 童亿虎“热处理工艺过程的微机群控-“JKC-1”
过程控制器, 邮电部上海电话设备厂, 1983.5。
- [4] 胡明娟、潘健生等, 微型计算机可控渗氮, 上
海交通大学, 1985.1。
- [5] 通用功能微机控制系统在气体渗碳中的应
用, 内部资料, 1985。
- [6] 周熙等, 3ZC10-13三室式真空热处理炉采用一
位微处理机简况, 上海机械制造工艺研究所,
1984。
- [7] 《机械工业自动化》, 1985.2。
- [8] 顾百揆等, 控制气体渗碳过程的微处理机系
统, 机械部第三设计院, 1984.10。
- [9] 高小捷、邱大年, 真空离子渗碳试验和计算
机数字仿真, 北京工业大学, 1983.3.31。
- [10] 胡昌桂, 用微处理机热处理可控气氛试
验, 中国农业机械化研究院工艺材料研究所, 1984.3。
- [11] 微处理机控制的激光加工设备及其应
用 华中工学院激光所, 1982.10。
- [12] 吴光英, 采用微机的可控渗氮新设备及其
应用, 南京摄山电炉厂, 1985.4。
- [13] 诸葛维乐、杜荣芬, 微机在中频感应淬火
中的应用, 江苏常州客车厂, 1984。
- [14] 王重威, TP-801单板机对热处理温度的
控制, 浙江隧昌县动力设备厂, 1984。
- [15] 赵高扬、陈仁悟, 滴注式渗碳过程中碳
势与气氛组成的关系, 陕西机械学院1985.3。
- [16] 黄春雷, 热处理工艺的计算机过程控制
及其应用程序的编制, 上海交通大学, 1985.4。
- [17] T. ERICSSON. Computer in Materials
Technology, 1980。

MICROPROCESSOR SYSTEM CONTROLLING GAS CARBURIZING PROCESS

Beijing JINSHU RECHULI [HEAT TREATMENT OF METALS] in Chinese No 10, Oct 85
pp 9-18

[English abstract of article by Gu Baikui [7357 4102 2247], et al., of the
Third Design Research Institute, Ministry of Machine Building Industry]

[Text] A microcomputer system based on a [Cromemco] Z-80 single board computer for controlling the gas carburizing process is discussed. The system has 7 analog input and output ports, 24 switchable digital input ports and 12 switchable digital output ports, applicable for temperature, carbon potential, and mechanical movement control of a multi-purpose sealed furnace, or for multiple zone temperature, carbon potential, mechanical movement control of a continuous gas carburizing furnace, or distributed control of a pit type carburizing furnace. The set points of various control variables, such as treatment time, temperature, carbon potential of the carburizing period, carbon potential in the diffusion period, depth of the carburizing layer, and parameters (P, I, D), etc., are entered by keyboard and stored into memory, and actual values are displayed by digital tubes. Furthermore, with regard to failing thermocouple, failing oxygen probe, failing infrared CO₂ analyzer, carbon potential or temperature exceeding the setting value, as well as when the process begins, cancels or ends, these are either displayed or alarmed.

The system is based on a mathematical model with three variables, i.e., either CO₂, CO and temperature or O₂, CO₂ and temperature, so as to control the carbon potential. Temperature is regulated and controlled by the P I D mathematical model. This model is written in assembly language on 2716 EPROM memories.

The structure of hardware and the block diagrams are presented. The software design principles and operating instructions are explained. This system has been applied to a 12kW electrically heated tube furnace and to control of the carburization process of piston pins of diesel engines in a 35kW pit type gas carburizing furnace. The results are excellent.

REFERENCES

- [1] A. D. TULLETT. M. F. HESSEY "微型计算机控制热处理气氛" 《HEAT TREATMENT OF METALS》, 1979.2, 41~45
- [2] J. Pavlossoglou: 气体渗碳数学模型的建立及其应用, 《H. T. M》, 1977, 32
- [3] J. Robert: 《Microprocessor in Instruments and control》, 1977, by John Wiley & sons, Inc
- [4] 朱绍庐: 《微型计算机》, 1982.
- [5] Lance A: 《Z80汇编语言程序设计》, 1981.
- [6] William Barden, Jr: 《The Z-80 Microcomputer Handbook》, 1978, by Howard W. Sams & co, Inc

PLASMA CARBURIZING EXPERIMENTS AND COMPUTER DIGITAL SIMULATION

Beijing JINSHU RECHULI [HEAT TREATMENT OF METALS] in Chinese No 10, Oct 85
pp 18-25

[English abstract of article by Gao Xiaojie [7559 1420 2212], et al., of
Beijing Industrial University]

[Text] The dynamics of plasma carburizing and technology parameters are
discussed based on the results of experiments. A mathematical model for
predicting the carbon concentration profiles of plasma carburizing steel
is constructed and the digital simulation is carried out with a TP-803
microcomputer.

REFERENCES

- [1] 高见茂、増田行男、真空イオン浸炭法、《真空》, 19, 1974, 6, 188-193
- [2] 米田芳之、イオン浸炭装置、《铸鍛造と熱処理》, 1978, 9, 71~78
- [3] William L. Grube. Progress in Plasma Carburizing, 《J. Heat Treating》, 1980, 3, 40~49
- [4] P. Collignon, 《Traitement Thermique》, 1978, 121, 43~53
- [5] Italo Montecchi, 《第十八届国际材料热处理文集》, 1980,
- [6] J. Pavlossoglou, 《Härterei-Technische Mitteilungen》, 36, 1981, 3, 115-119
- [7] D. G. Teer, 《J. Adhesion》, Vol18, 1977, 289-300

MICROCOMPUTER CONTROLLED NITRIDING

Beijing JINSHU RECHULI [HEAT TREATMENT OF METALS] in Chinese No 10, Oct 85
pp 25-35

[English abstract of article by Hu Mingjuan [5170 2494 1227], et al., of
Shanghai Jiaotong University]

[Text] A mathematical model is suggested that provides a theoretical foundation for overcoming the technical disadvantages in controlled nitriding, which include slow nitriding rate, shallow effective hardness penetration and poor reproducibility. On this basis, CAD for the controlled nitriding process, the microcomputer system for nitrogen potential control, and the microcomputer controlled nitriding process have been developed. Experiments showed the superiority of controlled nitriding with a microcomputer using the mathematical model at optimum diffusion conditions. It is able to improve microstructures and properties of the nitriding layer and to hold a high nitriding rate. This process has reproducibility sufficient for industrial practice.

REFERENCES

- [1] L. S. Darken, R. W. Gurry: 《Physical Chemistry of Metals》, 1953
- [2] T. Bell et al 《Heat Treatment'73》, 51~58
- [3] B. Edenhofer, 《Heat Treatment'79》 The Metals society, Condon, 52~59
- [4] 潘健生等《可控氮化的数学模式及其应用》国际材料与热处理大会第三届年会宣读论文, 1983
- [5] 潘健生等: 《氮化热力学》上海交通大学85周年校庆报告论文
- [6] 笛木和雄, 《日本金属学会会报》, 14, 1975, 2, 125~133

RELATIONSHIP BETWEEN CARBON POTENTIAL AND COMPOSITION OF FURNACE ATMOSPHERE
IN DROP-FEEDING CARBURIZING PROCESS

Beijing JINSHU RECHULI [HEAT TREATMENT OF METALS] in Chinese No 10, Oct 85
pp 35-41

[English abstract of article by Zhao Gaoyang [6392 7559 2254], et al., of
Shaanxi Mechanical Institute]

[Text] Drop-feeding carburizing experiments were conducted with methanol-
acetone drop-feeding agent, and the composition of the furnace atmosphere was
comprehensively analyzed by a gas chromatograph. According to the experimental
results, the relationships between carbon potential and composition of the
furnace atmosphere and the relationships among composition of furnace
atmosphere were studied by the theory of mathematical statistics. A relation-
ship between carbon potential and composition of furnace atmosphere was
obtained and the assessment of methods for controlling carbon potential
was discussed.

REFERENCES

- | | |
|------------------------------------|--|
| [1] 周志渊等,《金属热处理》,1982,2 | [6] 王志,氧探头对井式炉渗碳碳势的控制 哈尔
滨科学技术大学科技情报资料室,1979.3 |
| [2] 梅志强:滴注式可控气氛渗碳,第二届全国热
处理年会论文 | [7] 热处理化学编写组编:《热处理化学》,下册
1977,5 |
| [3] 顾百揆:渗碳气氛碳势控制 第二届全国热处
理年会论文 | [8] 石川邦彦,易泓可译,《国外化学热处理》,
1983,4 |
| [4] 榎下忠义,《热处理》,15,1975,4 | [9] R. Collin et al,《Journal of the Iron
and Steel Institute》,210,1972,10 |
| [5] 铁道科学研究院金化所,《金属热处理》,
1980,10 | [10] 曾秋成编:《技术数据统计方法》,1982,7 |
| | [11] 上海师范大学数学系编:《回归分析及其试验
设计》,1978,2 |

9717

CSO: 4009/1028

FUNCTIONAL AND DECOMPOSITIONAL PROGRAMMING

Nanjing NANJING GONGXUEYUAN XUEBAO [JOURNAL OF NANJING INSTITUTE OF TECHNOLOGY]
in Chinese Vol 16 No 1, 20 Jan 86 pp 103-112

[English abstract of article by Cheng Zhengchao [4453 2973 3390] of the
Department of Computer Science and Engineering, Nanjing Institute of
Technology]

[Text] A functional and decompositional programming approach is presented in this paper. The structures of program modules and relationships between the modules can be formally described by this approach. The descriptions are formal enough for directly processing, generating the code with existing programming languages and automatically verifying the correctness of the descriptions by computers. For this reason, if it is used as an approach to describe the specifications in the software design stage, the productivity of software development can be improved and higher reliability of software products may be expected. (Paper received 24 November 1984.)

REFERENCES

- [1] Jackson, M. A.: Principles of Program Design, London, Academic Press, 1975.
- [2] Backus, J.: Can programming be liberated from the von neumann style? —A functional style and its algebra of programs, Comm, ACM, Vol. 21, No 8, 1978: 613-641.
- [3] Katayama, T.: HFP: A hierarchical and functional programming based on attribute grammar. Proc. 5th Int. Conf. on Software Engineering, 1981.

9717
CSO: 4009/1036

Electronics

A MICROSTRIP EQUALIZER FOR TWT AMPLIFIER

Nanjing NANJING GONGXUEYUAN XUEBAO [JOURNAL OF NANJING INSTITUTE OF TECHNOLOGY]
in Chinese Vol 16 No 1, 20 Jan 86 pp 71-77

[English abstract of article by Zhang Guoxing [1728 0948 5281], et al., of
the Research Institute of Electronics]

[Text] Results referring to research on a reflection-type equalizer are presented. It is used as an external element in a TWT amplifier and constructed by microstrip line. The theoretical and experimental study is focused on two kinds of configurations--one consists of a 90-degree hybrid coupler and a particular reflective circuit, while the other could be designed with a low-loss circular instead of the coupler.

After appropriate adjustment, the final figures are: stage balance 5 dB at bandwidth of 3.5-7.5 GHz, 10-15 dB for 7.0-11.0 GHz, insertion loss 0.5-1.0 dB. When it is connected with a TWT, the maximum gain variation in TWT could be reduced from 10 dB to 5 dB. As a small element it could also be used in microwave integrated circuits. (Paper received 28 December 1984.)

REFERENCES

- [1] Fulvio Ananasso:, Two-point method speeds equalizer design, Micro-Waves, November 1978, 108.
- [2] Edwards T. C.: Foundations for Microwave Circuit Design, John Willey & Sons, 1981.
- [3] Waugh, R. and Lacombe, D.,: Unfolding the lange coupler, IEEE Trans., MTT-20, Nov. 1972, 777-779.
- [4] Presser, A.: Interdigitated microstrip coupler design, IEEE Trans., MTT-26, No. 10, October, 1978, 801-805.

CSO: 4009/1036

Engineering

ANALYSIS OF GYROMOTOR VIBRATION BY FINITE ELEMENT METHOD

Nanjing NANJING GONGXUEYUAN XUEBAO [JOURNAL OF NANJING INSTITUTE OF TECHNOLOGY]
in Chinese Vol 16 No 1, 20 Jan 86 pp 1-9

[English abstract of article by Wan Dejun [8001 1795 6874], et al., of the
Department of Automatic Control]

[Text] In this paper the mechanical models of gyromotors are established by virtue of the finite element method, and the method for calculating their natural frequencies is presented which takes into account the effects of axial loads, elastic supports and shearing function. A diameter conversion method of step-section and a general program for calculating the natural frequencies of gyromotors with ball bearings and stationary shafts are provided. The calculated results for a practical example are consistent with the experimental data. (Paper received 7 May 1985.)

REFERENCES

- [1] 马格努特 K.: 《陀螺理论及其应用》, 国防工业出版社, 1983年。
- [2] Gasch R.: Vibration of large turbo-rotors in fluid-film bearing on an elastic foundation, J. Sound and Vibr., 47 (1), 1976: 53.
- [3] Murty A. V. K.: Finite element analysis of rotor, Mech. Mach. Theo., Vol. 12, 1977: 31.
- [4] Rao S. S.: Finite element method in engineering, Pergamon Press, 1982.
- [5] Prezemieniecki J. R.: 《矩阵结构分析理论》, 国防工业出版社, 1980年。

MICROPROCESSOR CONTROL SYSTEM FOR WOOLLEN SWEATER JACQUARD LOOM

Nanjing NANJING GONGXUEYUAN XUEBAO [JOURNAL OF NANJING INSTITUTE OF TECHNOLOGY]
in Chinese Vol 16 No 1, 20 Jan 86 pp 97-102

[English abstract of article by Chen Weinan [7115 4850 0589], et al., of the
Department of Automatic Control, Nanjing Institute of Technology]

[Text] We have developed a new microprocessor control system for the woollen
sweater jacquard loom. The principle, main features, enlarged interface and
program flow diagram of the control system are described in this paper. The
paper also gives a brief description of the performance and technological flow
of the automatic jacquard loom. (Paper received 14 December 1984.)

CSO: 4009/1036

Mathematics

HYBRID FINITE ELEMENT ANALYSIS FOR INCREMENTARY THERMAL ELASTIC-PLASTIC PROBLEM

Nanjing NANJING GONGXUEYUAN XUEBAO [JOURNAL OF NANJING INSTITUTE OF TECHNOLOGY] in Chinese Vol 16 No 1, 20 Jan 86 pp 78-86

[English abstract of article by Li Zhaoxia [2621 0340 7209], et al., of the Department of Mathematics and Mechanics]

[Text] On grounds of the modified incremental principle of complementary energy, the authors demonstrate the use of hybrid element techniques for solving thermal elastic-plastic problems, and give formulas for thermal elastic-plastic analysis based on the initial stress method.

The necessity of equilibrium imbalance correction using small load increments without iteration is investigated. The error analysis and numerical evaluations show that the hybrid finite element method for thermal elastic-plastic stress analysis has an advantage over the displacement method; and that the equilibrium imbalance correction for thermal elastic-plastic stress analysis is of particular convenience and efficiency. (Paper received 4 December 1984.)

REFERENCES

- [1] Spilker, R. L.: A study of elastic-plastic analysis by the assumed-stress hybrid finite-element models, with application to Thick shells revolution, MIT ASRL TR 175-1, 1974.
- [2] Luk, C. H.: Assumed stress hybrid finite-element method for fracture mechanics and elastic-plastic analysis, MIT ASRL TR 170-1, 1972.
- [3] Spilker, R. L. and Pian, T. H. H.: Hybrid stress models for elastic-plastic analysis by the initial stress approach, Int. J. Num. Meth. Engng. 14, 1979: 359-378.
- [4] Pian, T. H. H., Tong P., Luk, C. H. and Spilker, R. L.: Elastic-plastic analysis by assumed stress hybrid model, Proc. of the 1974 Int. Conf. on F. E. M. in Engng. ed. by Pulmano V. A. and Kabaila A. P., Aug. 1974: 419-434.
- [5] Pian, T. H. H.: Nonlinear analysis by assumed stress hybrid models, Proc. 24th Japan National Congress of Applied Mech., Tokyo, Nov. 1974: 1-10.
- [6] Pian, T. H. H.: Derivation of element stiffness matrices by assumed stress distributions, AIAA. J. 2(7), July 1964: 1333-1336.
- [7] Pian, T. H. H.: Element stiffness matrices for boundary compatibility and for prescribed boundary stress, Proc. Conf. on Matrix Methods in Structure Mech. AFFDL-TR-66-80, 1966: 457-477.
- [8] Pian, T. H. H.: Variational principles for incremental finite element methods, J. of the Franklin Institute Vol. 302, No. 5-6, 1976.

- [9] 王跃平:《固体力学学报》,1983年3月。
- [10] Pian, T. H. H. and Chen, D. P.: Alternative ways for formulation of hybrid stress elements, Int. J. Num. Meth. Engng., 18, 1982: 1679—1684.
- [11] Tian Zongzha and Pian T. H. H., Axisymmetrix solid elements by a rational hybrid stress method, Computers and Structures.

IDENTIFICATION OF VIBRATION PARAMETER BY MICROCOMPUTER

Nanjing NANJING GONGXUEYUAN XUEBAO [JOURNAL OF NANJING INSTITUTE OF TECHNOLOGY]
in Chinese Vol 16 No 1, 20 Jan 86 pp 87-96

[English abstract of article by Lin Xunhong [2651 1789 3126], et al., of the
Department of Mathematics and Mechanics]

[Text] The principle of utilizing experimental data of transfer functions to carry out transfer function fitting and measures taken to raise fitting accuracy are introduced. Results of transfer function fitting by the microcomputer are compared with those obtained by the graphic method. The results show that the transfer function fitting method gives relatively higher accuracy than does the graphic fitting method. (Paper received 21 December 1984.)

REFERENCES

- [1] 张令弥: 机械阻抗方法在振动分析中的应用,《机械强度》 1980年第 2 期。
- [2] 林循泓、潘得引: Apple II 微型机在振动参数识别中的应用,《南京工学院学报》 1984年第 3 期。
- [3] 黄敦朴: 试验模态分析技术及其在工作中的应用,《全国第一次振动技术培训和咨询会议资料》 1984年 8 月。
- [4] 张巨洪等:《BASIC语言程序库》,清华大学出版社,1983年。

CSO: 4009/1036

Beijing BEIJING DAXUE XUEBAO (ZIRAN KEXUE BAN) [ACTA SCIENTIARUM NATURALIUM UNIVERSITATIS PEKINENSIS] in Chinese No 3, May 85 pp 1-10

[English abstract of article by Wen Guochun [5113 0948 2797] of the Department of Mathematics, Beijing University]

[Text] In this paper we discuss the nonlinear uniformly elliptic system of first order (1.1) in an $(N+1)$ -connected domain D . Without loss of generality, we assume that D is a circular domain in the unit disc, and suppose the system (1.1) satisfies the condition C as stated in a previous paper. The nonlinear discontinuous boundary value problem A for system (1.1) may be formulated as follows: Find a solution $w(z)$ of the system (1.1) to satisfy $w(z) \in W_{p_0}^1(D_m)$ (D_m is any compact subset in $D \setminus \{c_1, \dots, c_n\}$, $2 < p_0 < p$) and the boundary condition except at the discontinuity points c_1, \dots, c_n ($0 \leq n < \infty$), where $|\lambda(z)| = 1$, $r(z, w) = r_0(z)r(z, w)$, $s(z) = s_0(z) \prod_{j=1}^n |z - c_j|^{-\beta_j}$ ($0 \leq \beta_j/\alpha < 1$) satisfy the given conditions.

By using a priori estimates of solutions of the corresponding boundary value problem for the analytic function, the continuity method and Schauder's fixed point theorem, we prove the following main result.

Theorem. Suppose that the elliptic system (1.1) satisfies the condition C and the constant ϵ is sufficiently small.

- (1) When $K = \frac{1}{\pi} \Delta_{\Gamma} \arg \lambda(t) \geq 2N - 1$, Problem A is solvable.
- (2) When $0 \leq K \leq 2N - 2$, the total of the solvability conditions for Problem A $\leq N - [(K+1)/2]$.
- (3) When $K < 0$, Problem A has $N - K - 1$ solvability conditions.

As an application of the above theorem, we derive an existence theorem of nonlinear quasiconformal mappings which maps the domain D onto a band domain with N slits.

Finally, the author would like to thank Professor Begehr for valuable suggestions. (Paper received 20 February 1984.)

REFERENCES

- [1] 闻国椿 (Wen Guo-chun), On compound boundary value problems with shift for nonlinear elliptic complex equations of first order, *Complex Variables: Theory and Application*, 1(1982), 39-59
- [2] 闻国椿, 平面上-一阶非线性椭圆型方程组的黎曼-希尔伯特边值问题, *数学学报*, 23(1980), 244-255.
- [3] Гахов Ф. Д., Краевые задачи, Москва, 1958.
- [4] Тюрников Е. В., Нелинейная краевая задача Римана-Гильберта для квазилинейных эллиптических систем, *ДАН СССР*, 247(1979), 1068-1072.
- [5] 闻国椿, 一阶复方程于多连通圆界区域上解的积分表示式及其性质, *河北师范大学学报(自然科学)*, 1981, 1-2: 130-145.
- [6] 闻国椿, 多连通区域上的格林函数与各种边值问题解的积分表示, *应用数学与计算数学*, 1982, 1: 55-60.
- [7] Векун И. Н., *广义解析函数*, 人民教育出版社, 1960.
- [8] 闻国椿, 一阶非线性椭圆型复方程解的表示定理、凝聚原理与存在定理, *河北化工学院学报*, 1980年数学专辑, 41-61.
- [9] Мусхелишвили Н. И., *奇异积分方程*, 上海科学技术出版社, 1966.
- [10] 闻国椿, 多个未知函数的一阶非线性椭圆型方程组于平面多连通区域上的某些非线性边值问题, *北京大学学报(自然科学)*, 1983, 4: 1-12.

COMPOSITE OC FUNCTION OF SWITCHING RULES UNDER ISO 3951 (81)

Beijing BEIJING DAXUE XUEBAO (ZIRAN KEXUE BAN) [ACTA SCIENTIARUM NATURALIUM UNIVERSITATIS PEKINENSIS] in Chinese No 3, May 85 pp 11-18

[English abstract of article by Wang Renguan [3076 0088 1351] of the Department of Mathematics, Beijing University; and Cheng Hansheng [4453 5060 3932] of the Chinese Association for Applied Statistics]

[Text] In this paper we analyze the switching rules of ISO 3951, and obtain its signal flow graph to deduce the generating functions of the sequence of the switching probabilities $F_{N \rightarrow T}(x)$, $F_{N \rightarrow R}(x)$, $F_{T \rightarrow N}(x)$, $F_{T \rightarrow D}(x)$, $F_{R \rightarrow N}(x)$. Finally, we obtain composite OC functions and dynamic characteristics of ISO 3951 from the above results. In particular, we discuss overall dynamic characteristics by expected proportions. (Paper received 23 April 1984.)

REFERENCES

- [1] 小山健, "MIL-STD-105D におけるキピシサ調整の動特性の解(I)——動特性の理論解析", 品質管理 21:7(1970)
- [2] T. Koyama, "Switching Characteristics under MIL-STD-105D", Technometrics, 21:1 Feb 1979
- [3] T. Koyama, "Switching Characteristics under the ISO/DIS 3951 Sampling Scheme". ICQC 78 Tokyo Proceedings, D3-41(1978)
- [4] 汪仁官, "带有中断检查的调整型抽样系统的复合 OC 函数". 应用数学学8:1(1985)
- [5] ISO 3951(81) Sampling Procedures and Charts for Inspection by Variables for Percent Defective, 1981

CSO: 4009/1030

Physical Chemistry

CRYSTAL STRUCTURE OF ADDITION COMPOUND OF DECAVANADIC ACID AND ETHYLENE
DIAMINE

Beijing BEIJING DAXUE XUEBAO (ZIRAN KEXUE BAN) [ACTA SCIENTIARUM NATURALIUM
UNIVERSITATIS PEKINENSIS] in Chinese No 3, May 85 pp 57-64

[English abstract of article by Shao Meicheng [6730 5019 2052], et al., of
the Institute of Physical Chemistry]

[Text] The title compound crystallizes in the space group $C_{2h}^6-C_{21}/c$, with
unit cell constants $a = 20.264\text{\AA}$, $B = 17.209\text{\AA}$, $c = 10.548\text{\AA}$, $\beta = 103.603^\circ$.
Intensities of 2358 independent reflections were collected with a four circle
diffractometer using $\text{MoK}\alpha$ radiation. After reduction for diffractometer
data, first we derived the position parameters of all the V atoms by a
direct method using the SHELXTL program. The coordinates of all the non-
hydrogen and hydrogen atoms were obtained from successive Fourier and
difference syntheses. The block-diagonal least-squares refinement for all
atoms gave a final discrepancy factor $R = 0.065$.

The result of structure analysis shows that all six protons of each
decavanadic acid are captured by six nitrogen atoms involved in three
ethylenediamine molecules. In crystal, the isopoly decavanadate anions,
cations and the crystal water are linked together by ionic forces and
hydrogen bonding and the chemical content within a unit cell has been
identified as $4[\text{V}_{10}\text{O}_{28}]^{6-} \cdot 12[\text{H}_3\text{NCH}_2\text{CH}_2\text{N}^+\text{H}_3] \cdot 24\text{H}_2\text{O}$. (Paper received
11 September 1983.)

REFERENCES

- [1] 邵美成, 王丽峰, 张泽莹, 唐有祺, “十钒酸与5,7-二甲基-2,3-双氢-1,4-二氮杂草加合物的晶体结构”, 中国科学, B辑, 10(1983)875.
- [2] 邵美成, 张泽莹, 唐有祺等, “十钒酸二钠与六次甲基四胺加合物的晶体结构”, 中国科学B辑待发表.
- [3] H. T. Evans, Inorg. Chem. 5(№ 6) (1966), 967.
- [4] A. G. Swallow, F. R. Ahmed and W. H. Barnes, Acta. Cryst. 21 (1966), 397.
- [5,6] J. M. Arrieta, P. Gili and J. M. Amigo, J. Appl. Cryst. 14(1981)209; J. Appl. Cryst. 14(1981)472.

THE CRYSTAL STRUCTURE OF $\text{Na}_2\text{H}_4\text{V}_{10}\text{O}_{28} \cdot 14\text{H}_2\text{O}$

Beijing BEIJING DAXUE XUEBAO (ZIRAN KEXUE BAN) [ACTA SCIENTIARUM NATURALIUM UNIVERSITATIS PEKINENSIS] in Chinese No 3, May 85 pp 65-72

[English abstract of article by Zhang Zeying [1728 3419 3853], et al., of the Institute of Physical Chemistry]

[Text] The crystal structure of $\text{Na}_2\text{H}_4\text{V}_{10}\text{O}_{28} \cdot 14\text{H}_2\text{O}$ has been determined from three-dimensional X-ray diffraction data collected by the four-circle diffractometer. The crystal is triclinic with space group $P\bar{1}$, $a = 8.509(2)\text{\AA}$, $b = 10.414(2)\text{\AA}$, $c = 11.298(3)\text{\AA}$, $\alpha = 68.56(2)^\circ$, $\beta = 87.36(2)^\circ$, $\gamma = 67.22(2)^\circ$ and $Z = 1$.

The positional parameters of five vanadium atoms are derived from the Patterson function. The parameters of the other atoms are found from successive Fourier and difference syntheses. The final R index is 0.0407 after being refined by block-matrix least-square techniques.

The results of structure analysis show that there are complex ions $(\text{V}_{10}\text{O}_{28})^{6-}$ in the crystal. Among the six protons of decavanadic acid there are two protons which are replaced by two sodium atoms, while the other four protons are captured by water molecules to form the cation H_3O^+ . The binuclear hydrated sodium ions consist of two sodium ions and 10 water molecules. Therefore, the structural formula of the crystal is finally defined as

$(4\text{H}_2\text{O} \cdot \text{Na}^+ \begin{array}{c} \text{H}_2\text{O} \\ \diagdown \quad \diagup \\ \text{Na}^+ \\ \diagup \quad \diagdown \\ \text{H}_2\text{O} \end{array} \cdot 4\text{H}_2\text{O}) (\text{V}_{10}\text{O}_{28})^{6-} \cdot 4\text{H}_3\text{O}^+$. The compound is an important

intermediate product in wet metallurgy of vanadium. (Paper received 5 August 1983.)

REFERENCES

- [1] 于淑秋, 孟祥胜, 陈家镛, 《中国科学》1982, B, 1, 11.
- [2] M. T. Pope and B. W. Date, Quart Rev. 1968, 22, 527
- [3] 邵美成, 王丽峰: “十钒酸与乙二胺加合物的晶体结构”待发表
- [4] 邵美成, 王丽峰, 张泽莹, 唐有祺, “十钒酸与5,7-二甲基-2,3 双氢-1,4二氮杂革加合物的晶体结构”, 《中国科学》, 1983, B, 10, 875
- [5] 邵美成, 张泽莹等 “十钒酸与六次甲基四胺加合物的晶体结构”。《中国科学》待发表。
- [6] T. E. Howard, Inorg. Chem. 5, (1966), 967.

LUMINESCENCE OF Eu^{3+} ION IN $(\text{La}_{1-x}\text{Gd}_x)_2\text{O}_2\text{S}$

Beijing BEIJING DAXUE XUEBAO (ZIRAN KEXUE BAN) [ACTA SCIENTIARUM NATURALIUM UNIVERSITATIS PEKINENSIS] in Chinese No 3, May 85 pp 73-83

[English abstract of article by Lian Xishan [6647 6932 1472] of the Department of Chemistry, Nei Monggol University; and Huang Zhupo [7806 4554 0980], et al., of the Department of Chemistry, Beijing University]

[Text] In order to determine efficient luminescent materials, we have synthesized Eu^{3+} -activated binary systems of $(\text{La}_{1-x}\text{Gd}_x)_2\text{O}_2\text{S}$ and investigated their luminescent properties under the excitation of ultraviolet light, cathode rays and X-rays.

The matrix composition-dependence of their emission spectra, luminous brightness, chromaticity coordinates, decay time as well as particle size distribution is studied and discussed. The luminescent properties of $(\text{La}_{0.9}\text{Gd}_{0.1})_2\text{O}_2\text{S}:\text{Eu}^{3+}$ as a function of europium concentration have also been investigated. (Paper received 21 September 1984.)

REFERENCES

- [1] 黄竹坡, 郭凤瑜, 候品成, 高等学校化学学报, 2(4), 461(1981)
- [2] 郭凤瑜, 黄竹坡, 北京大学学报(自然科学), № 5, 81(1982)
- [3] 慈云祥等, 分析化学, № 4, P232(1982)
- [4] 黄竹坡, 许庚望, 发光与显示 № 1, 46(1982)
- [5] 黄竹坡, 许庚望, 高等学校化学学报, 4(3), 283(1983)
- [6] R. E. Shrader, et al, J. Lumin., 1(2), 814(1970)
- [7] W. H. Fonger, C. W. Strack, J. Chem. Phys., 52, 6364(1970)
- [8] L. Ozawa, et al, J. Electrochem. Soc., 118(10), 1678(1971).

9717

CSO: 4009/1030

DOMAIN STRUCTURES OF $\text{Fe}_{40}\text{Ni}_{40}\text{Mo}_4\text{B}_{16}$ AMORPHOUS METALLOY RIBBON DURING MAGNETIZATION

Beijing BEIJING DAXUE XUEBAO (ZIRAN KEXUE BAN) [ACTA SCIENTIARUM NATURALIUM UNIVERSITATIS PEKINENSIS] in Chinese No 3, May 85 pp 52-56

[English abstract of article by Wang Qintang [3769 0530 1016], et al., of the Department of Physics, Beijing University]

[Text] Using the conventional Bitter technique, the authors observed magnetic domain powder patterns on the free face of the As quenching $\text{Fe}_{40}\text{Ni}_{40}\text{Mo}_4\text{B}_{16}$ amorphous metalloy thin ribbon and their variations under the applied magnetic field. A vibration sample magnetometer and impulsive current meter were used to measure the magnetization curve of the sheet sample and ring sample respectively. Based on these, a discussion is made of the contribution of the various domains to the technical magnetization procedure and their effect on magnetic properties. (Paper received 23 June 1982.)

REFERENCES

- [1] J. J. Becher, AIP. Conf. Proc. **29**, 204(1976)
- [2] E. M. Gyorgy et. al., AIP. Conf. Proc. **29**, 198(1976)
- [3] Y. OBi et. al., Japan J. Appl. Phys. **15**, 611(1976)
- [4] H. Kronmüller et. al. J. M. M. M. **13**, 53(1979)
- [5] 王勤堂 万玉珍, 金属材料研究 Vol. 8 № 4. 21(1982)

Polymers, Polymerization

STUDIES OF ULTRASONIC DEGRADATION AND BLOCK COPOLYMERIZATION OF HYDROXYETHYL CELLULOSE AND POLY(ETHYLENE OXIDE)

Beijing GAOFENZI TONGXUN [POLYMER COMMUNICATIONS] in Chinese No 6, Dec 85
pp 401-407

[English abstract of article by Chen Keqiang [7115 0344 1730], et al., of the Polymer Research Institute, Chengdu University of Science and Technology]

[Text] The ultrasonic degradation of hydroxyethyl cellulose (HEC) and poly(ethylene oxide) (PEO) in aqueous solution and copolymerization of HEC with PEO were studied respectively. The copolymer structure was identified by DTA, IR, MS, X-ray diffraction and polarizing microscope, and the copolymer prepared is mainly a block one. The copolymer, formed by irradiation 0.5 percent HEC/PEO aqueous solution for a period of 10 minutes at 25°C and 18.2 kHz with 2.5 A input current on a reversed main circuit, amounts to 55.07 percent. (Paper received 26 August 1983.)

REFERENCES

- [1] Tatsuo Sato and David E. Nalepa, *J. Appl. Polym. Sci.*, **1978**, *22*, 865—867.
- [2] Bailey, F. E. Jr. and Ko'eske, J. V., "*Poly (ethylene Oxide)*", *Academic Press*, New York, **1976**, 48pp.
- [3] 李文端, 徐僖, 高分子通讯, **1983**, (1), 31—38.
- [4] 中川和明, 川瀬進, 加倉井敏夫, 高分子論文集, **1976**, 33(7), 399~404.
- [5] Ovenall, D. W., *J. Polym. Sci.*, **1960**, *42*, 458.
- [6] Attia, Y. A. and Rubio, J., *Brit. Polym. J.*, **1975**, *7*, 135—138.

SYNTHESES OF MACRO-POROUS HUMIC ACID RESINS AND THEIR CHELATING PROPERTIES FOR HEAVY METAL IONS

Beijing GAOFENZI TONGXUN [POLYMER COMMUNICATIONS] in Chinese No 6, Dec 85 pp 408-415

[English abstract of article by Chen Yiyong [7115 5030 6978], et al., of the Department of Chemistry, Hangzhou University, Hangzhou; and Zheng Ping [6774 1627] of the Institute of Chemistry, Chinese Academy of Sciences, Beijing]

[Text] Macro-porous humic acid resins (HAR) bearing -N=N- bonds or ester and/or ether bonds were prepared with crosslinked polystyrene derivatives and humic acids. Azo type HAR (AHAR) prepared under HA/PSNH₂ 0.7-1.0 (wt. ratio) and coupling pH 13 conditions has the best adsorption properties for metal ions. The adsorption quantities for Cu²⁺ of ester and/or ether type HAR (EHAR) increase with increasing reaction time of EHAR formation. The HAR structures were examined by IR-spectra. Adsorption capacities of AHAR for Cd²⁺, Ni²⁺, Mn²⁺, Cu²⁺, Co³⁺, Zn²⁺ are 1.01, 0.60, 0.59, 0.56, 0.55, 0.53 mmol ion/g resin, respectively. The distribution coefficients of metal ions on AHAR are Cu²⁺(8.7 × 10³) > Cd²⁺(3.8 × 10²) > Zn²⁺(2.4 × 10²) > Ni²⁺(1.8 × 10²) > Mn²⁺(4.9 × 10), respectively. Cu²⁺, Cd²⁺, Ni²⁺, Mn²⁺ ions can be quantitatively adsorbed and eluted by 1N HNO₃ with AHAR. The resin can be regenerated and reused. The trace heavy metal ions in four kinds of natural water and tap water have been determined. (Paper received 30 August 1983.)

REFERENCES

- [1] Chen, Y., Senesi, N. and Schnitzer, M., *Geoderma*, 1978, 20(2), 87.
- [2] 刘康德、郑平, 燃料化学学报, 1980, 8(1), 1.
- [3] Flaig, W., Beutelspacher, H. and Rietz, E., *Soil Components*, 1975, 1, 1-211, Edited by Gieseking, John E., Springer, New York.
- [4] Van Dijk, H., *Geoderma*, 1971, 5(1), 53.
- [5] 中川雅直, 金属(日), 1973, 43(3), 66.
- [6] 巴音、王兰, 环境科学, 1979, (1), 44.
- [7] 太原燃料化学研究所 307 组, 环境科学, 1977, (4), 44.
- [8] 寺島一生、富田繁、松田芳人、安部桂司、石上直代, 工業用水(日), 1973, 180(9), 22; 寺島一生、富田繁、松田芳人、安部桂司、村山彰、三井雅夫、赤堀禎利, 工業用水(日), 1974, 194, 38.
- [9] U. S. S. R. 351, 864.
- [10] Таджиев, А. Т., Юнусова, Д. Р., *Узб. Хим. Ж.*, 1968, (3), 68.
- [11] 日本公開特許, 昭 49-96988; *Chem. Abstr.*, 82: 102867 Y.
- [12] Moschopedis, S. E., Wood, J. C., Fryer, J. F. and Elofson, R. M., *Fuel*, 1964, 43(4), 289.
- [13] Moschopedis, S. E., *Fuel*, 1962, 41, 425.
- [14] Han, Kyoungsuk and Kim, Wontaik, *Dachan Hwahak Hwojee*, 1972, 16(5), 320; *from Chem. Abstr.*, 78; 17590a
- [15] 何炳林、钱庭宝、彭长久、李淑莲、侯文同, 高分子通讯, 1965, 7(3), 185
- [16] Davies, R. V., Kennedy, J., Lane, E. S., and Willans J. L., *J. Appl. Chem.*, 1959, 9(7), 368.
- [17] 陈义鏞、顧振楫, 高分子通讯, 1982, (6), 443.
- [18] Chen Yiyong and Gu Zhenmei, *Polym. Communi. (English Edition)*, 1983, (2), 152.
- [19] 河淵計明、菅家惇、村岡竜秀、山内美和子, 分析化学(日), 1976, 25(4), 213.

STUDIES ON GRAFT POLYMERIZATION OF SULFOALKYL METHACRYLATE ONTO SEGMENTED POLYETHER URETHANE FILM .

Beijing GAOFENZI TONGXUN [POLYMER COMMUNICATIONS] in Chinese No 6, Dec 85 pp 416-421

[English abstract of article by Huang Zuxiu [7806 4371 3811] and Chen Huiying [7115 1979 5391], et al., of the Department of Chemistry, Beijing University]

[Text] Graft polymerization of sodium salt of 6-sulfohexyl methacrylate (SSHMA) or sodium salt of 8-sulfo-octyl methacrylate (SSOMA) onto segmented polyether urethane (SPEU) film has been investigated.

The graft reaction included two steps: first a hydroperoxide group was introduced onto the surface of SPEU through photo-oxidation in the presence of hydrogen peroxide, then it was reduced by ferrous ion to initiate sulfoalkyl methacrylate grafting on the SPEU surface. The effect of the concentration of sulfoalkyl methacrylate, the concentration of ferrous ion and the reaction temperature on the graft polymerization is discussed. The grafted films possess a higher percentage of water absorption and anticoagulant activity than does the ungrafted SPEU film. The salient micrographs on the grafted film surface were taken by a scanning electronic microscope. (Paper received 6 September 1983.)

REFERENCES

- [1] Bruck, S. D., *Chem. Tech.* 1979, 7, 240.
- [2] Chen, W. Y., Xu, B. Z. and Feng, X. D., *J. Polym. Sci., Polym. Chem.*, ed. 1982, 20, 547.
- [3] 孙燕慧、丘坤元、冯新德, *高分子通讯*, 1983, 2, 81.
- [4] Lyman, D. J., Hill, D. W., Strik, R. K., Adamson, C. and Mooney, B. R., *Trans. Am. Soc. Artif. Inter. Organs.*, 1972, 18, 19.
- [5] 黄祖琇、冯新德, *科学通报(英文版)*, 1983, 5, 632.
- [6] Mair, R. D. and Graupner, A. J., *Anal. Chem.*, 1964, 36, 194.

INVESTIGATIONS OF THE TEXTURE AND SURFACE CHEMICAL STRUCTURE OF HOLLOW
ACTIVATED CARBON FIBER SNACF

Beijing GAOFENZI TONGXUN [POLYMER COMMUNICATIONS] in Chinese No 6, Dec 85
pp 429-434

[English abstract of article by Zeng Hanmin [2580 3352 3046], et al., of the
Polymer Research Institute, Zhongshan University, Guangzhou]

[Text] The texture and surface chemical structure features of hollow activated
carbon fiber SNACF have been investigated using TEM, SEM, XPS, IR, X-ray
diffraction and chemical titration techniques, etc. The experimental results
show that the SNACF is an activated carbon fiber containing N and S, possessing
porosity and microcrystalline-carbon structure with basic functional groups
and acid functional groups -COOH phenolic-OH, etc., as well as high-oxidized
sulfur, such as sulphonic acid functional groups, on its surface. (Paper
received 10 September 1983.)

REFERENCES

- [1] 曾汉民,郭锡坤,中大科研情报, 1981(1), 1.
- [2] 曾汉民,丛广民,郭锡坤,简念保,杨二全,合成纤维工业, 1982(4), 35.
- [3] 曾汉民,郭锡坤,吴桂强,环境科学丛刊, 1984, 5(2), 11.
- [4] 曾汉民,郭锡坤,潘纯华,高分子通讯, 1985(6), 422.
- [5] 曾汉民,郭锡坤,合成纤维工业, 1984(3), 6.
- [6] 三机部六二一研究所编《用浸胶法测定高模量纤维拉伸性能试验方法》,内部资料.
- [7] 永田洋文,吉田正俊,化学经济, 1977(4), 44.
- [8] Lin, R. Y., Economy. J., *Appl. Polym. Symp.*, 1973, 21, 143.
- [9] Economy, J., Lin, R. Y., *Appl. Polym. Symp.*, 1976, 29, 199.
- [10] [日]染野 檀,安盛岩雄编,《表面分析》,科学出版社,1980年12月.
- [11] Ishitani, A., *Carbon*, 1981, 19(4), 269.

DISCUSSION OF 'ANCHIMERIC EFFECT' OF HYDROXYMETHYL EPOXY RESIN

Beijing GAOFENZI TONGXUN [POLYMER COMMUNICATIONS] in Chinese No 6, Dec 85
pp 440-444

[English abstract of article by Jin Shijiu [6855 1102 0046], et al., of the
Institute of Chemistry, Chinese Academy of Sciences, Beijing]

[Text] *o*- and *p*-Hydroxymethyl phenyl glycidyl ethers were synthesized as model compounds of hydroxymethyl diglycidyl ether bisphenol A type epoxy resin. It was reported to give more rapid cures at lower temperatures with amines for having a hydroxymethyl activating group. The reactions of these compounds with methylene dianiline (MDA) were investigated by means of DTA and IR for the discussion of "anchimeric effect" suggested by Schwarzer. (Paper received 16 September 1983.)

REFERENCES

- [1] Cupples, A. L., Lee, H. and Stoffey, D. G., in "Epoxy Resins" (Gould, R. E., Editor), American Chemical Society, 1970, p. 173.
- [2] Schwarzer, C. G., 25th Ann. Tech. Conf. Reinforced Plastics/Composites Division, SPI, 1970, 3-A.
- [3] 中国科学院化学研究所工作报告: "羟甲基环氧树脂的合成及在室温固化胶粘剂中的应用", 1971.
- [4] 晨光化学工业研究院工作报告: "速固化羟甲基环氧树脂-硫脲己二胺体系的合成及应用", 1974.
- [5] Shecter, L., Wynstra, J. and Kurkij, R. P., *Ind. Eng. Chem.*, 1956, 48(1), 94.
- [6] Smith, I. T., *Polymer*, 1961, 2, 95.
- [7] Tanaka, Y. and Mika, T. F., in "Epoxy Resins Chemistry and Technology" (May, C. A. and Tanaka, Y., Editors) Marcel Dekker, New York, 1973, p. 135.
- [8] Bowen, D. O. and Whiteside, R. C., in "Epoxy Resins" (Gould, R. F., Editor), American Chemical Society, 1970, p. 48.
- [9] 瀬戸正二, 堀内光, *工化*, 1954, 57, 689.
- [10] 金士九, 顾菊瑛, *高分子通讯*, 1981(3), 206.

ACTIVITIES OF BUTADIENE POLYMERIZATION USING PHENOXY NEODYMIUM DICHLORIDE
TETRAHYDROFURAN AND NEODYMIUM TRICHLORIDE PHENOL COMPLEXES COMBINED WITH
ALUMINUM ALKYL

Beijing GAOFENZI TONGXUN [POLYMER COMMUNICATIONS] in Chinese No 6, Dec 85
pp 452-456

[English abstract of article by Yu Guangqian [0060 1639 6197] and Chen Wenqi
[7115 2429 0796], et al., of Changchun Institute of Applied Chemistry,
Chinese Academy of Sciences]

[Text] $C_6H_5ONdCl_2 \cdot nTHF$ (THF=; $n = 0, 1, 2$) and $NdCl_3 \cdot HOAr$ (HOAr =

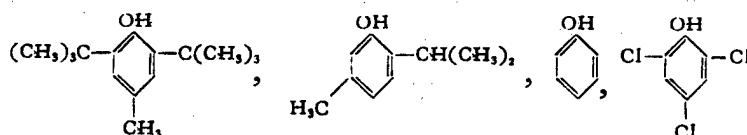

combined with aluminum alkyls are highly active for butadiene polymerization.

In $C_6H_5ONdCl_2 \cdot nTHF-AlR_3$ system the activities increase with an increase in
the coordination number of THF. In $NdCl_3 \cdot HOAr-AlR_3$ the polymerization
activities of various phenols are in the following order:

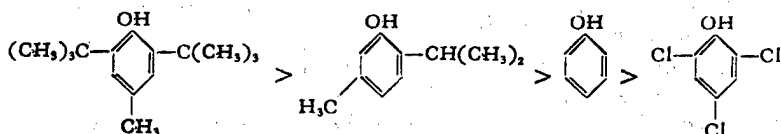

The polymerization rate is first order with respect to the monomer concentra-
tion in $C_6H_5ONdCl_2 \cdot 2THF-Al_i-Bu_2H$. The plot of the conversion vs polymeriza-
tion time is linear. The $[\eta]$ of the polymer decreases with an increase in
the butadiene conversion. (Paper received 7 September 1983.)

REFERENCES

- [1] 日本特許, 昭 54-40890(1979); 昭 55-12189(1980).
- [2] 单成基、李玉良、逢束芬、欧阳均, 化学学报, 1983 41(6), 490.
- [3] 中国科学院吉林应用化学研究所四室三组, 中国科学, 1974, (5), 486.
- [4] 陈文启、于广谦、包晓华、暴长赋, 化学学报, 1985, 43(1), 79.
- [5] 钱汉英、于广谦、陈文启, 高分子通讯, 1984, (3), 226.
- [6] 仲崇祺、杨继华、逢束芬、扈晶余、谢德民、欧阳均, "稀土催化合成橡胶文集", 科学出版社, 北京, 1980, 210.

9717
CSO: 4009/1032

END