

R
234042

JPRS-WST-85-018

20 June 1985

West Europe Report

SCIENCE AND TECHNOLOGY

19981022 029

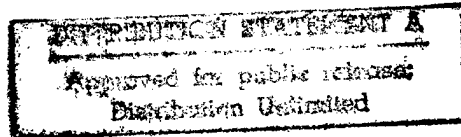

DTIC QUALITY INSPECTED

FBIS

FOREIGN BROADCAST INFORMATION SERVICE

REPRODUCED BY
NATIONAL TECHNICAL
INFORMATION SERVICE
U.S. DEPARTMENT OF COMMERCE
SPRINGFIELD, VA. 22161

6
71
A04

NOTE

JPRS publications contain information primarily from foreign newspapers, periodicals and books, but also from news agency transmissions and broadcasts. Materials from foreign-language sources are translated; those from English-language sources are transcribed or reprinted, with the original phrasing and other characteristics retained.

Headlines, editorial reports, and material enclosed in brackets [] are supplied by JPRS. Processing indicators such as [Text] or [Excerpt] in the first line of each item, or following the last line of a brief, indicate how the original information was processed. Where no processing indicator is given, the information was summarized or extracted.

Unfamiliar names rendered phonetically or transliterated are enclosed in parentheses. Words or names preceded by a question mark and enclosed in parentheses were not clear in the original but have been supplied as appropriate in context. Other unattributed parenthetical notes within the body of an item originate with the source. Times within items are as given by source.

The contents of this publication in no way represent the policies, views or attitudes of the U.S. Government.

PROCUREMENT OF PUBLICATIONS

JPRS publications may be ordered from the National Technical Information Service, Springfield, Virginia 22161. In ordering, it is recommended that the JPRS number, title, date and author, if applicable, of publication be cited.

Current JPRS publications are announced in Government Reports Announcements issued semi-monthly by the National Technical Information Service, and are listed in the Monthly Catalog of U.S. Government Publications issued by the Superintendent of Documents, U.S. Government Printing Office, Washington, D.C. 20402.

Correspondence pertaining to matters other than procurement may be addressed to Joint Publications Research Service, 1000 North Glebe Road, Arlington, Virginia 22201.

20 June 1985

WEST EUROPE REPORT SCIENCE AND TECHNOLOGY

CONTENTS

AEROSPACE

- Small-Scale Model of Ariane 4 in Testing
(Gilles Patri; REVUE AREOSPATIALE, May 85)..... 1

AUTOMOBILE INDUSTRY

- Application of Plastics in Production Model Automobiles
(Michel Meilleray; L'ARGUS DE L'AUTOMOBILE, 21 Feb 85).... 5
- New Casting Process at Citroen of France
(FRANKFURTER ZEITUNG/BLICK DURCH DIE WIRTSCHAFT,
1 Apr 85)..... 10
- Series Production of Antiskid System at FRG Firm
(FRANKFURTER ZEITUNG/BLICK DURCH DIE WIRTSCHAFT,
10 Apr 85)..... 11

BIOTECHNOLOGY

- Briefs
Biogen Consolidates Facilities 13

FACTORY AUTOMATION

- Swiss Lab Develops Sighted, Tactile Robots
(Bruno Rewyl; ELECTRONIQUE, Oct 84)..... 14
- Report Analyzes Weaknesses of FRG Machine Tool Industry
(INDUSTRIEMAGAZIN, Apr 85)..... 17

MICROELECTRONICS

- Research, Activities, Organization at France's LETI
(Eric Marshall; ZERO UN INFORMATIQUE HEBDO, 18 Feb 85).... 23

SCIENTIFIC AND INDUSTRIAL POLICY

- Olivetti Reports First Half, 1984 Results to Shareholders
(NOTIZIE OLIVETTI, Oct 84)..... 32
- Olivetti Acquires 49.3 Percent of British Acorn
(L'INFORMATICA, Feb 85)..... 39
- New Max-Planck Research Centers in FRG 1985 Budget
(TECHNISCHE RUNDSCHAU, 22 Jan 85)..... 40
- Ways to Improve FRG Venture Capital Climate Studied
(Walther Konhaeuser, Hubert Pratschke; ELEKTRONIKER,
Jan 85)..... 42
- Ciba-Geigy 1983, 1984 Earnings by Branch
(CHEMISCHE RUNDSCHAU, 18 Jan 85)..... 45
- Use of Loss Carryback in FRG Income Taxes
(Michale F. Raubal; INDUSTRIEMAGAZIN, Apr 85)..... 46
- EC To Promote High-Tech Research Cooperation With 'Brite'
(CHEMISCHE RUNDSCHAU, 18 Jan 85)..... 48
- FRG Government Measures to Further Civil R&D Detailed
(FRANKFURTER ZEITUNG/BLICK DURCH DIE WIRTSCHAFT,
8 Mar 85)..... 49
- Government To Encourage Foreigners to Conduct R & D in Italy
(INFORMATICA 70, Mar 85)..... 58
- Fiat's Agnelli Explains European Venture Capital Initiative
(IL TEMPO, 23 Mar 85)..... 60
- High-Tech Application, Support Policy Succeeds in FRG State
(Uwe Vorkoetter; DIE ZEIT, 5 Apr 85)..... 62
- Legal Status of FRG Research Institutes for Tax Purposes
(FRANKFURTER ZEITUNG/BLICK DURCH DIE WIRTSCHAFT,
11 Apr 85)..... 66

AEROSPACE

SMALL-SCALE MODEL OF ARIANE 4 IN TESTING

Paris REVUE AEROSPATIALE in French May 85 pp 4-7

[Article by Gilles Patri: "Ariane 4 Has Already 'Flown'... at ONERA, in Wind-Tunnels and on Mini-Launch Pads"]

[Text] Ariane is a launcher in constant evolution. Since model 1, whose first flight already dates back to 24 December 1979, there have been Ariane 2 and 3. Tomorrow, in 14 months from now, it will be the turn of Ariane 4 to take off from the new "ELA 2" launch pad of the Kourou CSG [Guiana Space Center].

Far more powerful with its four booster propulsion units, and taller than the older model, Ariane 4 will also be more economical since it will make it possible to lower by 60 percent the average cost per kilogram in orbit. A windfall for its clients. Wind-tunnel testing at the ONERA [National Office for Space Study and Research] progressed at a fast pace, even before construction of the launcher was completed. The ONERA has even already carried out tens of Ariane-4 "flights" at altitudes of up to 60 km... using models!

The "Ariane-4" launching campaigns are completed... in the ONERA wind-tunnels and on the ELA-2 mini-launch pad at Palaiseau near Paris. Indeed, since the creation of the launcher, the ONERA has been playing a dual role in the career of Ariane: technical assistance to the prime contractor, the CNES (National Center for Space Studies); and provider of services, in particular to the industrial architect (Aerospatiale) and the engine manufacturer (SEP [European Propulsion Company]).

Already for Ariane 1, the ONERA engineering and design departments and their resources as well as the engineers of the above-mentioned companies had been called upon to provide their services. A series of aerodynamic, thermal and acoustic tests was just completed on Ariane 4.

The Launcher Flight

"Before going off into space, Ariane must go through the atmosphere. Therefore, for the atmospheric flight leg, the aerodynamic characteristics of the launcher must be rated just as if it were an aircraft, and the overall forces exerted on the rocket as well as their distribution must be specified..."

Since this research cannot be carried out in full scale, these simulations are made on high-precision stainless steel models (at model scale, the protruding parts of the launcher can have dimensions on the order of millimeters).

"Several models have been used. The scale used is the largest possible scale compatible with the size of the wind-tunnels: 1/55th for the model tested at Modane, in wind-tunnels S2 and S3 where the complete launcher flight is simulated up to Mach 4; 1/100th models of the second and third stages in the (supersonic and hypersonic) wind-tunnels of Chalais Meudon."

During these tests, hundreds of sensors transmit the flight characteristics to computers. The results are then processed by the manufacturers, in particular by Aerospatiale.

On Ariane, the study of interactions between the aerodynamic flow and the elasticity of the structure is essential, especially around the transsonic stage, i.e. when the shock wave appears on the nosecone, creating large pressure fluctuations that can cause the structure to vibrate.

"Separation test have also been carried out on the booster propulsion units," Jean-Jacques Dordain continued, "to check that this maneuver will not risk damage to the rest of the launcher. For these tests, we are using an original computer-controlled device with six degrees of freedom, which can simulate the path of a booster propulsion unit according to the separation characteristics."

Real Motors

In addition to wind-tunnel tests, thermal and acoustic tests have also been carried out in the open, using two different models equipped with real motors that were accurate replicas of the Viking motors (except for the cooling system). The scales of the models used were 1/20th and 1/40th.

"These small-scale models have the same performance characteristics as the launcher, and the small motors are using the same propellant components, in this case UDMH [unsymmetrical dimethylhydrazine] and nitrogen peroxide. The gas temperature reaches 3000°C and the nozzle throats are made of tungsten. Of course, the side booster propulsion units are also represented. They are made in Bourges for the powder-propellant version (Ariane AR44P version) and at the ONERA for the liquid-propellant version (AR44L)."

The launch pad is also reconstituted as a model. Whereas the takeoff of Ariane 1 and 3 was simulated at Palaiseau on a launch-pad model identical to the ELA-1 launch pad, the takeoff of Ariane 4, on a scale of 1/20th, is

simulated at Le Fauga, on an "ELA-2" launch pad which is also an accurate replica of the Kourou launch pad in Guiana.

The tests are used to simulate various launcher altitudes (from 0 to 23 m in full scale, i.e. from 0 to 1.15 m on the mini-launch pad.

"During each test," Jean-Jacques Dordain explained, "the model is kept at a given altitude and its position is changed from one launch to the next. Each test lasts 1 second on the average. What we are measuring is the thermal flow on the launch pad and on the rear part of the launcher. Pressures are also measured at various points of the vehicle, and especially on the nosecone, since it is important to know what the acoustic environment around the payload will be. We don't want to risk damaging a satellite during takeoff..."

Although 1 second may seem a short time, it is long enough to enable the measurements made by the hundreds of sensors attached to the model to reach their stabilized values.

The thousands of data recorded are of course swallowed by computers and, at the rate of two launchings per week on the average, they are enough to fill hundreds of meters of computation pages which are processed and analyzed.

"These measurements are very useful. For instance, for Ariane 1 they enabled us to make changes on the launch pad. For Ariane 4, the results are still being processed..."

Thermal Environment

The last type of test carried out on Ariane 4, on a 1/40th-scale model (the 1/20th scale is too big) starts again in the wind tunnel.

"We are then interested in studying the thermal and mechanical environment," Jean-Jacques Dordain concluded, "by simulating the Mach numbers encountered at various altitudes, and therefore under various atmospheric pressures. We are still receiving some 100 measurements in real time during each motor test. In that case, too, a test lasts 1 second. This type of tests, up to Mach 3, is done in Modane. Then, additional testing is done under various degrees of vacuum, in our A75 cell at Palaiseau. There, we can no longer simulate speed, but what interests us then is the outer pressure. Obviously, it is decreasing and we are simulating, roughly, an altitude of 60 km..."

The results achieved by Ariane 4 in all these tests have already made it possible to quantify a number of points and validate specifications.

Already, it has nearly been declared "fit for service"...

PHOTO CAPTIONS

1. p 4 Study of acoustic and thermal phenomena by simulating the takeoff of Ariane 4, with powder-propellant booster propulsion units (A44P configuration), on the ONERA launching pad of the Le Fauga-Mauzac Center (model and launch pad scale: 1/20th).

2. p 5 Separation tests on a booster propulsion unit of Ariane 3 in the Modane S2 wind-tunnel, on 1/55th scale models. The computer controlled-device with six degrees of freedom used in this wind-tunnel makes it possible to reconstitute the initial path of the propulsion unit as a function of separation conditions.
3. p 5 Study of the interaction of the motor jets of the first stage of Ariane 4 and of the external flow, in the S2 wind-tunnel of the Modane-Avrieux Center (model scale: 1/40th).
4. p 5 Note the precision of the details of this Ariane 1. This model will be exhibited at the Paris Museum of Sciences and Technology.
5. p 6 Study of the interaction of the motor jets of the first stage of Ariane 4 and of the external flow, in the S2 wind-tunnel of the Modane-Avrieux Center (model scale: 1/40th).
6. p 6 S3 wind-tunnel (Modane-Avrieux Center): determination of the local aerodynamic coefficients of Ariane 4, clean version (model scale: 1/50th).
7. p 7 It flies... "tied down" for the study of acoustic and thermal phenomena through takeoff simulations, with liquid-propellant booster propulsion units (A44L configuration) at the launching pad of the Le Fauga-Mauzac Center (model and launch pad scale: 1/20th).

9294

CSO: 3698/449

AUTOMOBILE INDUSTRY

APPLICATION OF PLASTICS IN PRODUCTION MODEL AUTOMOBILES

Paris L'ARGUS DE L'AUTOMOBILE in French 21 Feb 85 pp 24-25

[Article by Michel Meilleray]

[Text] Current mass production applications are still rare and partial. However, Citroen with the BX (nearly 1000 cars per day), and on a smaller scale, Renault with the Alpine and GM with the Pontiac Fiero, are opening the way for plastic bodies. In these three cases, it is the improvement and development of new chemical conversion processes which have made it possible to use plastics to build car bodies. The die is cast, and the coming months will confirm the foresight of these pioneering manufacturers. Along with the builders, fabricators have played their role in this plastics breakthrough. In Italy, Comind, a plastics specialist in the Fiat group, is a good example of the many facets exhibited by a fabricator's activity. These concrete illustrations will make it possible to close for now this look at "plastics and automobiles."

As well demonstrated by the Renault Alpine, the old technique of reinforced polyester, fiberglass impregnated by hand, is no longer adequate for the production of plastic bodies, even in small batches. Two techniques are essentially used for the time being: SMC (sheet molding compound), which occurs in the form of sheets which are cemented together for thickness, and pressed into shape; and BMC (bulk molding compound) or ZMC-type derivatives (on the Citroen BX), which is found in the form of paste and is fabricated by injection molding. Briefly, flat and simple shapes are most often fabricated from SMC, a rapid and economical process. To improve surface conditions, it is possible to use the IMC (inmold coating) technique, which consists of opening the mold during pressing in order to deposit a surface layer that improves the final appearance. Lastly, complicated parts are presently reaction injection-molded (RIM) whenever they involve large numbers, since the machinery investment is still very high. This technique is undergoing evolution with the completion of current research in the simultaneous molding of several parts, including metal inserts. In addition, suppliers, fabricators, and manufacturers are presently working on the development of synthetic deformable structures, so as to build a quasi complete plastic car

in terms of safety standards (collision standards). Polyurethane resins fabricated by reaction injection, should produce deformable bumper inserts (soft nose) as a first stage, as demonstrated by the Porsche 928 or the Pontiac Fiero, which use this technology.

The Citroen BX is certainly the production model car which includes the largest number of plastic parts. This 11 percent integration is to be compared to the forecasts of the first part of this inquiry (ARGUS No 2920, 24 January 1985). Built in collaboration with Vetrotex Saint-Gobain and SMTP-Billion as suppliers, Stratiner (hood) or Inoplast (rear interior panels) as fabricators, and Manducher and Citroen for the rear hatch, plastic parts utilize several processing techniques depending on their end use. The BX experience, whose production costs can now be analyzed as a function of advantages and disadvantages, is an exemplary success.

SMC for the Hood

This involves hot tool compression molding during polymerization, with injection (IMC) during processing to improve the surface condition. The part is then deburred and punched to receive accessories. Installed on the car, the hood is painted at the same time as the rest of the car. Lighter (a gain of 5 kg over the same metal part), the plastic hood is only 10 percent more expensive than its metal equivalent. Given the weight gain, corrosion resistance, shock resistance, and ease of repair, the 10 percent increase in cost becomes negligible and compensated. For the time being, the production rate of this pressing technique is still inadequate, and the polymerization time (currently four minutes) will remain a difficult obstacle.

ZMC for the Rear Hatch

ZMC is the French name for generic BMC injection molding. This is a proprietary Vetrotex (Saint-Gobain group) formulation in the form of a bulk preimpregnated material. The raw material, contained in barrels in a temperature controlled building, is introduced into a heated hopper, then injected under pressure into a mold, in a cycle that takes one and one-half minutes. The process, which can be mechanized, is faster than compression molding of SMC sheets and remains open to many developments (metal inserts, multimolding, and so on). Given the number of functions, the cost of the BX rear hatch is equal to that of a steel one, which in any case could not be fabricated in an identical shape. Fabrication is integrated partly in the Rennes plant, and partly subcontracted to Manducher.

In addition to these major parts, the Citroen has other synthetic body parts, such as polyamide air vents or door latches, or the lateral roof edges replacing the traditional gutters (compression molded SMC fabricated by Grillo). The Citroen BX experience shows that some plastics are in a good position to advantageously replace steel sheet metal, even in terms of cost. This first mass production experience will undoubtedly be imitated by many other manufacturers.

ELEMENTS AMOVIBLES ET OUVRANTS CONSTITUANT LA CARROSSERIE

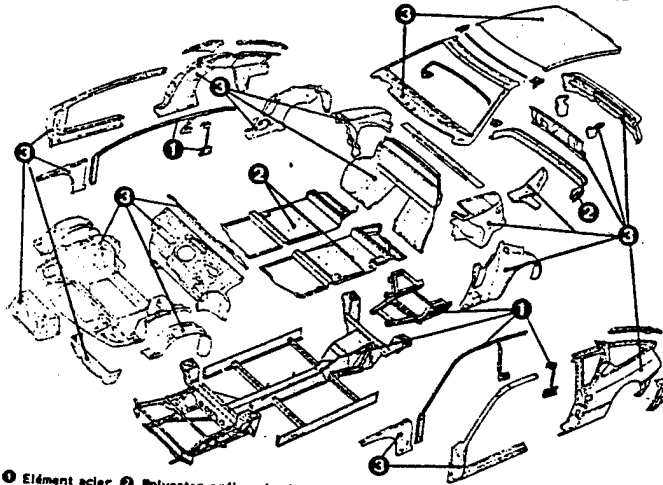

① Élément acier ② Polyester préimprégné haute pression ③ Polyester stratifié basse pression

Removable and opening parts composing the body

- Key:
1. Steel part
 2. High pressure preimpregnated polyester
 3. Low pressure stratified polyester

ECLATE DES PIECES CONSTITUANT LA COQUE NUE

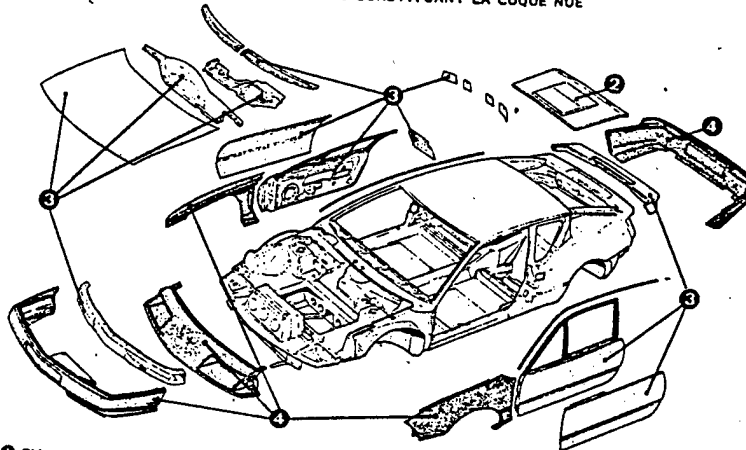

① Eléments acier ② Mousse de polyester armée de fibre de verre ③ Polyester stratifié basse pression ④ Polyuréthane

Exploded view of parts composing the bare shell

- Key:
1. Steel parts
 2. Polyester foam reinforced with glass fibers
 3. Low pressure stratified polyester
 4. Polyurethane

Small Batch: Renault Alpine

As for previous productions, the new Alpine is manufactured from a composite material, once commonly known as "stratified polyester." In Alpine's case, the major parts are fabricated from unsaturated polyester resins reinforced with fiberglass, while parts which have to withstand shock without permanent deformation (bumper inserts, front fenders, front grille, and so on), are made from polyurethane resins. While the type of material has varied little in name, in terms of actual materials and processes we are pretty removed from the conventional formulas used a few years ago.

Gain of 50 Hours!

All the Alpine bodies that combined two parts in one single piece (shell and floor), were manufactured by the conventional "cold contact" method. After the mold was painted with a gel coat (determining the surface condition), the fiberglass reinforcements placed in the mold were manually impregnated with liquid polyester resin. Additives (catalyst and accelerator) incorporated in the resin produced a polymerization chemical reaction to solidify the whole. Well understood, this fabrication method has the drawback of being very long (minimum of six hours' wait between impregnation and complete polymerization), and of requiring a great deal of care (wax finishing the mold, elimination of air bubbles, with surface condition being determined by the care used during manual impregnation).

The method is entirely different for the new Renault Alpine. The body is built from an assembly of parts cemented together, obtained by a process which results in more constant surface conditions and mechanical characteristics, while reducing the fabrication duration: pressure, low temperature molding, with the product being automatically metered and placed into two-section molds (coating for the polyester and injection for the polyurethane). The polymerization then takes place at 50 degrees C under a pressure of about 2 bars. The mold opens automatically after only a few minutes, to offer the finished part.

The parts are then cemented together and to the chassis on a special mechanized assembly line to assure the reliability of the joints (controlled duration of cement coating, clamping time, and temperature). The completely assembled body-chassis then moves to the painting line. The duration of fabrication is thus reduced from 120 to 70 hours, together with optimized quality and the possibility of increasing production volume.

Comind: Italian-Style Fabrication

In Italy, Comind SpA, wholly owned by Fiat, is part of the Italian company's Components activity, and the plastics division devotes itself almost exclusively to the automobile and heavy equipment sector.

Through its seven plants, of which one in France and one in Spain, in 1983 Comind produced 1.25 million dashboards, 1.1 million steering wheels, 1.5 million door panels and consoles, 400,000 bumpers and grilles, and more than 10 million square-meters of simulated leathers and calendered products. While Fiat absorbs 60 percent of the production, the remainder goes to European manufacturers of automobiles, heavy equipment, or agricultural machinery.

In addition to its affiliation to the Fiat group, which provides it with advantageous financial and technical connections, Comind is a good example of chemical conversion industry integration. The Stars unit in Turin produces essentially calendered products, interiors, and tanks (blown polyethylene extrusion technique), while the Politecna (Turin) and Comind Sud (Naples) specialize in body and exterior parts. A mold production unit (Tea and Montelli), one for interior heating (Riscaldatori), and two foreign plants (in France and Spain), assure Comind's complete technical autonomy in processing and raw material conversion. This autonomy is reflected in the investment plan, with 15 billion lire for product development costs in 1983, and 25 billion lire for technical investments. The latter point remains the key entry for the next several years, and the essential factor for the development of plastics in the automobile sector has become the competitiveness of production tooling.

In Conclusion

Michelotti and GM have greatly expanded the integration of synthetic materials into automobile bodies. Both of them have felt the need to use an internal rigid structure which is then "dressed" with plastic panels: it is a return to the good old chassis! It's somewhat true (but nothing prevents them from building a shell and then cladding it), but that is not where the stakes lie. GM is currently working on five-year model redesign cycles, and everything leads us to think that this time scale will decrease even further. In this "erector set" system with autonomous platform or chassis on one hand, and a cladding skin on the other, a change in body panels is all that is needed to inexpensively create a number of variations or a new model. Under this assumption, it is evident that plastics will play an important role. For cycles shorter than five years it would become impossible to amortize the cost of sheet metal tooling, and plastics would become particularly economical. For the time being, this is one possible scenario (among others), and the future will tell if it is the most realistic.

11,023
CSO: 3698/448

NEW CASTING PROCESS AT CITROEN OF FRANCE

Frankfurt/Main FRANKFURTER ZEITUNG/BLICK DURCH DIE WIRTSCHAFT in German
1 Apr 85 p 7

[Article: "New Casting Process at Citroen. The "Lost Foam Process Replaces the "Lost Form" Process"]

[Text] In the Citroen casting plant of Clichy the traditional "lost form" casting process has been revolutionized. No longer is the wax mold the basis, which upon heating up and liquification leaves prints in a ceramic mass true to dimensions; instead, polystyrol is used which dissolves like foam and eventually evaporates entirely.

Cast parts of an automobile are usually made of cast iron or aluminum. They account for four fifths of the total weight of the vehicle. Therefore, production progress in this area is of special significance. In the Chichy casting plant the Citroen specialists are testing a new casting process in a long series of tests, which can be called "lost foam" technology in contrast to the traditional "lost form" process.

In the conventional casting process molten metal was cast in sand molds under the impact of gravity and pressure; these molds were equipped with casting cores (for the cavities). The molten metal cooled and cured in the mold which was then taken off, releasing the desired cast item. Protruding burrs and uneven spots had to be carefully ground off in an additional process. This traditional casting method was replaced by a new process at the Citroen plant.

In a similar manner as with the "lost form" process, a basic mold is worked with, which, however, is no longer made of wax, but of polystyrol and is covered by a sand layer which is kept liquid. The sand layer is compressed, thus adhering to the casting mold like a second skin. Subsequently, molten metal is cast into the "baking dish," burns the polystyrol mold and causes its evaporation and then replaces it exactly. A renewed liquefication of the sand mold permits easy access to the new cast item.

The advantages of the process are manifold: The production of the tool is simple, and the costs are low. Grinding and final polishing are no longer necessary. The problematic release of the cast cores is eliminated.

Furthermore, the savings in time mean savings in money; and the new process permits a remarkable range of applications due to the versatility of the material used. For informational purposes, Citroen had an impressive video presentation made on the "lost foam" process.

AUTOMOBILE INDUSTRY

SERIES PRODUCTION OF ANTISKID SYSTEM AT FRG FIRM

Frankfurt/Main FRANKFURTER ZEITUNG/BLICK DURCH DIE WIRTSCHAFT in German 10 Apr 85 p 5

[Article: "ATE Improves Antiskid System/Ford Scorpio to Receive First Series Production/Dual Microprocessors"]

[Text] Only about three percent of all passenger cars registered in the Federal Republic are equipped with antiskid equipment (ABS). This is to change: Scientific tests of accidents with wheels locked by braking show that up to 7.5 percent of all accidents could be avoided if maneuverability in braking situations is maintained. The maneuverability of vehicles with brakes being fully applied is the decisive safety advantage of four-wheel controlled antiskid systems. Not only is overbraking of the rear axle and the resulting skidding hazard avoided, but drivers will be able to avoid an obstacle even if the full brake application alone does not suffice to avoid an accident.

Alfred Teves GmbH, Frankfurt, (ATE) started developing antiskid systems as early as 20 years ago. ATE is now introducing a system to the European automobile market that is a series-manufactured feature of the new Ford "Scorpio" car and has at least the performance of conventional antiskid systems. The ABS MK II by ATE is the first series-produced antiskid system optimized as to weight and space which incorporates the design and functioning of the braking action, the brake servo-unit cylinder and the hydraulic ABS control in a single compact unit.

The ABS by Teves can be mounted without additional hydraulic corrections at the firewall in the engine compartment of any passenger car like a regular brake servo-unit cylinder. No additional mounting expense is incurred, as is the case for conventional "add-on" systems (i.e., antiskid systems which are "added" to the brake servo-unit cylinder of a braking system) since the antiskid system by ATE includes the brake application/servo unit as an integral part. The components of the ATE system are the hydraulic unit, the electronic controller, and four inductive sensors.

An essential feature of the hydraulic unit is the dynamic admission port principle which was able to be achieved due to the overall design using a single hydraulics medium (brake fluid) at high pressure levels and an

independent power supply. With standard braking circuit distribution (front/rear axle), diagonal and three-circuit distribution, this dynamic admission port principle not only permits a weight advantage, but particularly a comfortable braking pedal feeling (no pulsation) and minimum response times during antiskid control. The respective wheel in danger of locking triggers the control via its own sensor (select-low principle).

During ABS pressure modulation, for instance, in a three-circuit braking system with one magnetic valve pair each, three phases are controlled per circuit, i.e., the pressure reduction phase, the pressure maintenance phase, and the pressure buildup phase. The hydraulic-mechanical system and the electromagnetically controlled ABS unit are balanced in such a manner that the control commands of the electronic controller always keep the pressure modulation in the range of optimum braking force transmission.

The electronic ABS controller processes the signals (frequency information) of the four wheel velocity sensors independently of one another and computes data which correspond to the vehicle's speed and the skidding wheel slip. The electronic controller converts these values into magnetic valve control signals for pressure modulation during control. The electronic ABS controller represents the first use of microprocessors in the modern development of passenger car antiskid systems. At a speed of 130 kilometers per hour, for example, almost 8,000 pieces of sensor information are processed each second. The control logic comprises two microprocessors whose program structures are identical.

9544
CSO: 3698/405

BIOTECHNOLOGY

BRIEFS

BIOGEN CONSOLIDATES FACILITIES--The Project--Biogen wants to gradually combine all its Geneva activities at a single location. For this vast project, it has selected the Meyrin-Satigny industrial zone, near Geneva. The work will proceed in three stages. The production laboratory, which will start its operations during the fall of 1985, is the preliminary stage of the project. It will cover an area of about 4000 square-meters and will employ 40-50 people (university personnel, technicians, workers, and specialists). This laboratory will produce gamma-interferon and interleukine-2 intended for clinical studies. Second and Third Stage--In addition to the production laboratory, by 1992, Meyrin's facilities will cover research and development, and medical research laboratories, as well as all the company's administrative departments, adding up to 300 persons. [Excerpt] [Aarau ELECTRONIQUE in French Nov 84 p 49] 11,023

CSO: 3698/445

FACTORY AUTOMATION

SWISS LAB DEVELOPS SIGHTED, TACTILE ROBOTS

Aarau ELECTRONIQUE in French October 84 pp 19-20

[Article by Bruno Rewyl]

[Text] Automobile plants abroad are not the only ones to use robots. In Switzerland as well, industry will find it increasingly difficult to operate without these skillful and speedy steel workers. Actually, the impressive automatic devices which weld bodies or assemble cars or machines, are too coarse for fine work, such as watchmaking. They are also too slow and not sufficiently precise. Another robot family is thus being born.

Specially designed for precision work, they will be miniaturized, will have visual and tactile "organs," and will work fast, faster than human workers, in performing routine tasks. The Microtechnology Institute of the Lausanne Federal Polytechnic School (EPFL) is actively participating in this new development.

A spot of red light produced by a zigzagging laser beam on the edge of a part. The spot stops. Some words immediately appear on a screen: "Part number 1." This is not an advanced electronic game of the future, but a very real test in the laboratory of the Microtechnology Laboratory at EPFL. The device is performing a difficult task: automatic shape recognition. "Unknown part," it declares without hesitation, when it is shown a part that does not exist in its electronic memory.

This device is a prototype for an industrial robot vision system. The objective is to identify and locate parts moving along a belt or laid out on a pallet. "It's student work," points out professor Christof W. Burckhardt, director of the institute. "The system will have to be improved before it can be used in industry; it will have to become more reliable and ten times faster. Right now, the identification process takes a whole second."

When one part partially covers another, the machine often "panics." The identification is successful as long as the visible outline is characteristic and sufficiently long. There is also the problem of pierced parts: the laser beam can become "trapped" by a hole punched in a part, following the edge of

the opening, turning around in a circle; it cannot identify the part because it cannot feel its outer edges, the "interesting" contour which is stored in its memory. Another problem is that the mirror galvanometers which deflect the laser beam are very expensive; a more economical solution will have to be found.

Groping Light Spot

Burckhardt however, believes that he is on the right path. To begin with, these faults can be remedied; it is a matter of time and money. But mainly, the method is a simple one. The use of a video camera for instance, is more laborious, because it requires analysis of an image composed of hundreds of thousand points. By comparison, the EPFL method needs less computer capacity and electronic memory since it takes into account only the part's contour. The laser beam sweeps the field of vision while a photocell measures the light intensity reflected by the part. When the beam moves beyond the edge, the intensity changes, causing a variation in the cell's output signal. The entire operation is computer controlled.

The laser beam proceeds in this manner, weaving on and off the part's border, a little like a drunk guiding himself along the edge of the sidewalk. The red light spot "gropes," tracing a shoestring trajectory. The computer records the position of each threshold point, thus determining the shape of the part, which it compares to contours stored in its memory. When a match does occur, the electronic system displays the result. In a complete robot, the computer will order the articulated arm to grab the part for the next operation.

Well Apportioned Strength

In order to perform certain tasks, such as polishing, spot welding, or assembly of small parts, a robot must be capable of carefully apportioning its strength. For instance, it must tighten a screw without weakness or excess force. The robot's articulated arm will therefore be equipped with a "sense of touch" in the form of a force sensor capable of determining up to six parameters at once: force components in the three directions, and torque components around three axes.

Researchers at the Microtechnology Institute have been working on this problem for several years, and have developed several prototypes. One of them is located in the wrist of the articulated arm. It consists of two rigid aluminum disks which move with the force, thus changing the current in electric coils. The system measures this current and determines the forces that have caused it. The sensor is not affected by pollution; it weighs only 340 grams and takes little space, since it is only 9 centimeters in diameter and 3.5 centimeters thick. It is however still too expensive for some applications.

That is why the Microtechnology Institute is now studying another technique, which uses electrodes instead of coils. In this instance, the system measures the electrical capacity between the electrodes, which behave like a condenser.

This solution is still not totally without problems. According to Burckhardt, "the difficulty is that the measurement circuit has its own capacitance effect, which combines with that of the electrodes and can mask it; but new miniaturized electronic circuits now make it possible to build very sensitive sensors."

Hydraulic Arm Without Tremors

The Microtechnology Institute does not develop only "organs" for future robots. It also builds Pegasse, a small steel slave which works at very high speed: it should achieve a rate of three parts per second in transfer tasks. The articulated arm will have to perform this back and forth motion without a tremor! This requires a particularly rigid structure. Burckhardt plans to use hydraulic actuators instead of electric motors. A pump brings oil under pressure to the arm's articulations. A computer controls the opening and closing of valves for the liquid so as to obtain different movements. The free end of the arm is equipped with a pneumatic head which picks up the parts by suction, and unloads them with a slight overpressure.

The hydraulic solution is not novel in itself; it has already been used for large robots. The Microtechnology Institute now intends to test it for small robots. A prototype already exists for simple operations, but has not yet reached the desired speed.

A Market Slot for Switzerland

About 40,000 robot are now installed in the world, with about 100 in Switzerland. But far from being a potential user of these perfected automatic devices, our country wants to take its place as producer, primarily in the area of small robots, a market slot which is not yet crowded.

In this respect, the Microtechnology Institute is not working in an ivory tower. On the contrary, it is striving to encourage our industry by training specialists and acting as consultant. This stimulus is largely responsible for the formation of two Neuchatel companies which have been manufacturing precision robots for a few years.

11,023
CSO: 3698/445

REPORT ANALYZES WEAKNESSES OF FRG MACHINE TOOL INDUSTRY

Munich INDUSTRIEMAGAZIN in German Apr 85 pp 102-110

Text Once again, orders are on the increase and machine tool manufacturers are breathing a sigh of relief. But the order boom has its hidden pitfalls; it hides dangerous structural weaknesses of the sector.

The banquet hall of the venerable Kempinski luxury hotel at Gravenbruch was filled to the last seat. About 250 managers and directors--all members of the Association of German Machine Tool Manufacturers (VDW) in neighboring Frankfurt--listened attentively as Roland Berger, the consultant from Munich, presented a strategic study of conditions in their sector.

The machine tool managers heard little encouraging news on the 16th of May of last year. The sector, according to Berger:

- had lost some market shares to the Japanese, worldwide;
- is badly positioned, especially in the U.S. growth market, and is only strong in shrinking markets;
- is in danger of losing out as well in flexible manufacturing systems, a small, but promising market segment, and
- must fear the third Japanese wave: the Asians, who until now concentrated on lathes and processing centers, are now getting into special machine tool construction, the German domain.

Altogether, the study of the Munich consultant, the summary of which consists of 322 pages, reveals a whole series of severe weaknesses regarding costs, market conditions and technology (see Table 1). Quite a few of his listeners in Gravenbruch learned the meaning of fear when Berger predicted that half of the about 380 domestic machine tool manufacturers would be out of business by the year 2000.

No Cause of Rejoicing

Today, many of those who met at Gravenbruch consider the prognosis as too pessimistic. Orders are now at an unprecedented high: in 1985, the German machine tool industry will increase its production for the first time in 4 years--by about 10 to 15 percent, according to estimates by VDW statistician

Dr Gutmann Habig (Production value of the sector in 1984: about DM9.7 billion). Even a company like Bielefeld's Gildemeister AG, which has been affected for years, is dreaming of a 20 percent sales increase.

But there is little cause for rejoicing. The optimistic reports of the German machine tool manufacturers "cannot obscure the dangerous structural weaknesses of the sector," warns Hans-Joachim Holstein, sales manager of Maho & Company, the successful Pfronten milling and drilling specialists.

During the past 10 years, their weak points have cost many medium-sized companies their existence or independence: nearly 70 of the formerly 450 companies were unable to keep up any longer with the fast technological changes--from individual numerical control machines via the manufacturing center to the flexible production cell. Such well-respected firms as Brose, Munich, and Lindner & Jung, Berlin (both have resumed their production in the meantime) for Abach in Aschaffenburg, gave up. Others fled under the wings of larger companies. Blohm in Hamburg and Schaudt in Stuttgart joined Hauni, the Mosbach Diedesheim GmbH went with Thyssen, and Burkhardt & Weber in Reutlingen became part of Georg Fischer (Switzerland).

High Entry Barriers

After 2 years of work, the Berger analysis, commissioned by the VDM for DM1 million, soberly pinpoints the ailments of the sector as follows:

--Most manufacturers have entered the NC field much too late and then only with hesitation. The high entry barriers into this market were--and remain--unsurmountable for many manufacturers working with small quantities. They lack the know-how, personnel and hardware to establish their own electronic development and an "efficient service, spare parts, advisory/training organization." For the small firms, also the NC control is too expensive. Those who can only buy in small numbers, have to pay more. Many control equipment suppliers only accept shipments above a certain minimum quantity. The result: NC machinery production is today in the hands of about 20 suppliers, who handle about 80 percent of the business.

--The sector suffers from excessive "complexity costs," i.e., the selection of parts is too large. Also, very small lot sizes tend to result in manufacturing costs that are too high. "The typical lot size" of almost 70 percent of all producers is "below 10."

--Willingness to cooperate is modest. Since many companies want to retain all manufacturing phases, the rise of production costs is disproportionately high. The chance to divide the work, which benefits everyone, is being wasted.

--As a rule, German machine tool manufacturers lack the courage to diversify. They timidly stay with their original product--maybe lathes or milling machines of all types--and are thus doubly susceptible to cyclical changes in their sector.

--The majority of companies keeps looking to the construction of special machines (such as for heavy machinery and plant construction), which is the traditional domain of German suppliers, to save them. But even this position is in jeopardy. Between 1980 and 1983, the Japanese tripled their production of specialized machinery, especially for the solution of problems in the automobile and in the semiconductor industries.

--And finally, many of the medium-sized German machine tool manufacturers--only 18 producers have more than 1,000 workers--lack the financial cushion to "withstand the everincreasing demands of international competition." Those who do not invest in modern and efficient manufacturing technologies are rarely able to compete, both in terms of technologies and prices.

Although, overall, the German machine tool industry continues to export more than any other nation equipments to all parts of the world, its lead is declining. While, in 1981, it supplied a good one-fourth of total world exports, today the percentage has decreased to only 22 percent. The Japanese, however, are catching up. Today, they are already providing 19 percent of all exports (1981: 16 percent).

Fragmented Sales Operations

A particularly bitter pill: companies like Okuma, Yamazaki (Masak), Ikegai or Mori Seiki are dominating the largest and most important import market of the world, the United States, primarily with mass-produced NC standard lathes and manufacturing centers. Their share of U.S. imports rose 10-fold during the past 10 years to about 45 percent, while the import share of German suppliers during the same period shrank from 40 percent to half of that amount.

At the same time, the domestic machine tool manufacturers are frequently careless in sacrificing their initial successes in newly industrializing and developing countries because they "are fragmenting" their sales activities without systematic planning. They make a forced effort to conquer such markets as Brazil or India, i.e., countries which already are working to attain self-sufficiency, rather than concentrate their efforts on countries with a high degree of imports, like Mexico or South Africa, which--according to the VDW study--demonstrate a good chance of achieving "general industrial development" (VDW study). The American competitors, primarily Bridgeport Machine Tools in Connecticut, are faster, with simpler, less expensive milling machines.

Only about 20 German suppliers, experts estimate, are maintaining or expanding their international market position. Among them are such top companies as Trumpf GmbH & Co Machinery Factory Stuttgart at Ditzingen, and Maho in Pfronten as well as Traub at Reichenbach and Scharmann in Moenchengladbach.

With great determination, the small circle of successful firms had focused from the start on the new numerical control technology. Their courage to take on risks, their willingness to innovate, in addition to a sound capital basis led this group to become leaders in their sector.

At Traub, for instance--as marketing manager Ernst Ehmann noted--80 percent of sales is manufactured by machines that are less than 4 years old. The Swabians expect to invest in 1985/86 about DM15 million in new manufacturing equipment. In addition, the company plans to spend 8 percent of its profits on production development (DM200 million planned for 1985).

Trumpf Director Berthold Leibinger is offering something unprecedented. He had a sheet-metal processing machine designed that "is programmable by the operator himself in dialog fashion" (CAD/CAM in the workplace).

However, not everyone of these 20 producers can be one of the top leaders in this still young, but vigorously expanding business of flexible manufacturing systems (FFS)--expected annual growth rates range between 20-30 percent; maybe half of them will succeed, an associate of Munich's consultant Berger estimates. The basic reason: here, the barriers to enter the market are even higher than in NC technology. (See also INDUSTRIEMAGAZIN November 1984: "Fertigungsautomation" /Manufacturing Automation/).

Japanese Have Advantage

Unlike the conventional machine tool business--with or without numerical control--, "the FFS business has the character of a system/equipment business, the Berger paper says. Thus the value-added structures in a plant are changing more and more in the direction of software development, planning know-how and engineering.

However, few German machine tool manufacturers have much experience in this area. Even among the innovative market leaders, few have so far "played the role of general entrepreneur"; most companies have remained "suppliers with little planning." Here, Japanese suppliers (e.g., Toyota) and some Americans (Kearny & Trecker, White Sundstrand) have an advantage in most instances. They usually operate under the umbrella of large concerns that are very experienced in planning.

Another danger for the small group of domestic FFS suppliers is that they take wrong market positions. So far, they have offered very adaptable and flexible systems that are able to process 100 and more different work pieces. However, the worldwide demand for such equipments is very small. The Japanese operate differently: according to the study, they have already, analyzes the study, adapted themselves with their products to the requirements of most potential customers. As a rule, their systems process "only" 10-40 different work pieces.

Thus, the machine tool makers--even the successful ones--face an abundance of problems. But Berger also has some encouraging words for the industry: Germany's continuing position as a market leader in Western Europe and the COMECON countries, its good reputation as a customer-oriented problem solver, the quality and reliability of the machine program, the broad spectrum of its products and, last but not least, the availability of top specialists, who are the envy of other nations--both skilled workers and designers--"offer an excellent starting basis" for the development of specific marketing and product strategies.

Clearly, Berger's study has caused some kind of uproar. The data bank that was set up on the basis of his findings has been "very well accepted" in Frankfurt, according to the VDW. Also, Berger himself has given about 40 presentations in industry and is developing concrete strategies for about 10 companies.

Those who do not move, fears Hans Joachim Holstein, marketing manager of Maho (the Pfronten company has no difficulties), "will soon disappear from the market place or will wind up on the sidelines." The new technologies are ruthlessly separating the chaff from the wheat.

Table 1: Lack of Courage and Strategies: Weak Points of the German Machine Tool Sector

Weaknesses in Market/ Competitive Position

German machine tool manufacturers rank first in retrogressive (COMECON countries) or stagnating markets (Western Europe and other OECD countries, except the United States and Canada).

Fragmentation of marketing activities in newly industrialized and developing countries (slowly increasing market), strategic concepts are scarce. Insufficient consideration of political market access barriers to exports. Brazilian attempts to attain autonomy in machine tool manufacturing.

Increasingly, middle-class structure of German machine tool industry (average of 250 workers) is inadequate to meet growing requirements of competition. Insufficient capitalization and financial weakness delay production modernization.

Loss of market share in growing U.S. market. Here, the Japanese are active with inexpensive standard lathes and work centers. Hence, access to U.S. electronic know-how (computers, peripherals, semiconductor production equipment) limited.

Cost Disadvantages

Wage disadvantages compared to almost all competitors (compared with Japan almost 30 percent).

Delayed utilization of modern, productivity-enhancing manufacturing technologies (NC, FFS) in machine tool production.

Traditional lack of willingness to cooperate. This leads to excessive costs in some manufacturing areas.

Compared with other countries, complexity costs excessive. Because diversity of parts is too large, lots are small, series sizes too small. Other cost disadvantages: suppliers of small orders are often forced to "attach" several control devices as required by users.

Technological Weaknesses

Systematic, market-oriented product development only in rare instances. Generally, weak research and development efforts (2.8 percent of 1983 sales).

Delayed entry into numerical control technology, endangering international competitive position (NC machine share of total production in 1984 about 28 percent, in Japan 60 percent).

Large new technology catchup required in machine tool production itself.

Deficit in power electronics. Market volume for NC controls in Japan twice that of United States and FRG combined.

Delays in production of flexible manufacturing system (FFS). In FRG, 20-30 FFS installed or being planned at this time, in Japan almost 100.

Insufficient courage to diversify (technologically). Thus susceptible to cyclical fluctuations.

Danger of being forced to accept smaller market share as result of developing products that are too complex. Inadequate attention to cost problems of users. Difficult entry into the systems business (FFS) because of widespread lack of planning and design know-how.

7994

CSO: 3698/422

MICROELECTRONICS

RESEARCH, ACTIVITIES, ORGANIZATION AT FRANCE'S LETI

Paris ZERO UN INFORMATIQUE HEBDO in French 18 Feb 85 pp XIV-XV

[Article by Eric Marshall: "Voyage to the Center of the LETI"]

[Text] This was a fine opportunity. On 20 February, the CUEFA [Adult Education and Training University Center] was opening its doors to the Sixth Grenoble Symposium on Microcomputers, and we thought it would be interesting to present one of the best performing research organizations in France, the LETI (Electronics and Data-Processing Technology Laboratory), most of whose activity involves microelectronics.

The LETI does not have the somewhat closed and aloof appearance which is usually said to be that of French research. The CEA (Atomic Energy Commission) laboratory does not want to do art for art's sake, but on the contrary to study anything that can lead to practical applications and result in industrial spin-offs.

The LETI was created as part of the CEA in 1967. Located at the Grenoble Nuclear Research Center (CENG), it now possesses 25,000 m², including 6,000 m² devoted to microelectronics alone, which have only just been inaugurated.

The LETI is searching, finding... and passing on the baton. In several ways: through the sale of licenses and technical dossiers resulting from specific research; in some cases through technical assistance to implement new technologies; through the installation of industrial teams; or again through its participation in setting up and running companies.

Forming part of the IRDI (Technological Research and Industrial Development Institute), the LETI is working 60 percent for manufacturers, its goal then being to develop a product that can be manufactured and marketed. It is therefore not engaged only in pure research. We should add that 15 percent of its resources are devoted to the service of the CEA and problems of a nuclear nature.

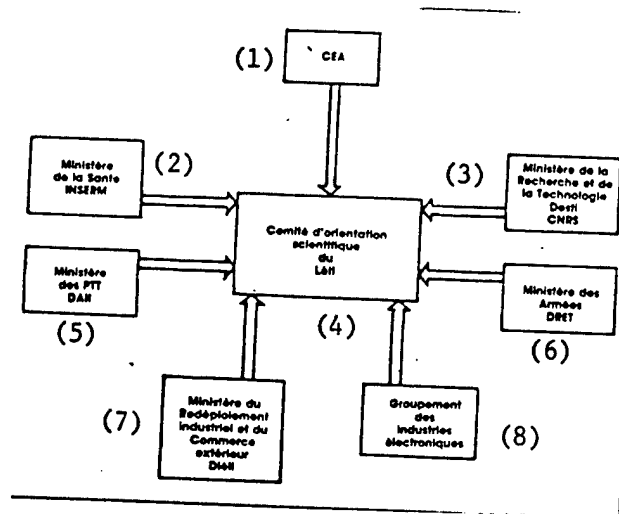

Key:

1. Atomic Energy Commission
2. Ministry of Health - INSERM [National Institute for Health and Medical Research]
3. Ministry of Research and Technology - DESTI [Directorate for Scientific and Technological Development and Innovation] - CNRS [National Center for Scientific Research]
4. Scientific Orientation Committee of the LETI
5. Ministry of Posts and Telecommunications - DAAI [Directorate of Industrial and International Affairs]
6. Ministry of Defense - DRET [Directorate of Research, Engineering and Technology]
7. Ministry of Industrial Redeployment and Foreign Trade - DIELI [Directorate of Electronics and Data-Processing Industry]
8. Electronic Industries Association

Three Branches

The 600 or so agents of the LETI are working in three [as published] main branches: materials (68 researchers); electronic components (211 people); instruments and systems (150 people); and the Infrared Laboratory (94 researchers). In addition to this population, there are the usual administrative services, making up a total of a little under 600 people.

- For the materials sector, there is a crystallography and research laboratory working on the development of materials for industrial uses: magnetic materials for bubble memories, microwaves, superconductors and magnetic-optic applications; dielectrics for piezoelectric devices; optical applications, sensors or again semiconductors for the whole microelectronics sector.

- The components sector includes two laboratories: input-output components and microelectronics. They work essentially on the development of basic processes in the context of certain advanced technologies: lithography and masking, ion implantation, heat treatment, annealing, thin-layer deposition, etc., and on the development of products such as silicon integrated circuits, bubble memories, infrared or guided-optic devices, or again devices derived from the Josephson effect.

- The sector of instruments and systems, finally, is subdivided into three major sections: an independent section for physics and metrology instruments; a section for geophysical applications and interventions in extreme media; and a measurement, control and electronic processing laboratory (general and nuclear electronics, signal processing, high-speed electronics).

This is where the most advanced research in robotics and vision systems is taking place.

Flat-Plane Liquid-Crystal Displays

You might be tempted to believe that, as far as displays are concerned, the Japanese would be about the only ones to be capable of carrying out a consistent research and development policy and the industrialization of the completed products, especially in the most difficult fields, like that of flat-panel displays. Well, it is not just quite like that.

At the LETI, there is a laboratory, that of input-output components, employing about 70 people and headed by G. Labrunie, which--even if it cannot boast of results as spectacular as those obtained by the Japanese Sharp or Epson--is demonstrating that it has acquired an evident knowhow and that it is in a position to transfer it to the industry (and has already done so in some cases).

All-Out for Liquid Crystals

For nearly 15 years, the LETI has been working on liquid crystals, the only technology in which it made an all-out investment to develop flat-panel displays (at the LETI, there is no mention of plasma or electroluminescent

displays). And it has done so in well-defined directions, corresponding to as many different processes:

- First, there is the so-called direct multiplexing display process using twisted nematic crystals. A field in which the Japanese unfortunately have a somewhat excessive lead. Witness the DG One portable micro-display of Data General: 25 lines of 80 characters with an excellent graphics resolution.

- Then, there is the electrically-controlled birefringence process (BCE), still in the direct multiplexing mode. A process which the LETI has known since 1973 and which it believes is well-suited to the applications considered, if only because of its high multiplexing rate (several hundreds of lines) and its remarkable electric-optical qualities.

At any rate, that is the method which the LETI used to develop its first "near" industrial product for the Planetel company, a joint subsidiary of SINTRA [Industrial Company for the New Radioelectrical Technologies and French Electronics]-Alcatel.

This product is a BCE flat-panel in the transmission mode (i.e. with built-in rear lighting) that can be connected to the Minitel network whose functional characteristics it emulates: 250 x 320 pixels in the graphics mode, or 25 lines of 40 characters in the text mode, over a useful area 87.5 x 112 mm². Images are displayed with 8 levels of grey, at the rate of 5-10 images per second. It is truly compatible with Minitel, but flat.

Still using the BCE method, and still at the request of Planetel, the LETI is now evaluating a transmissive trichrome display that would make it possible to present images and data in color. Latest form of the BCE display, derived from the transmissive mode: the reflective mode that does not require any large research investment. Its main advantage is that it requires only a very small energy consumption.

On an Integrated Control Matrix

Despite all their qualities, previous filters will eventually give way to a new technology, that of liquid crystals on an integrated control matrix. A new generation consisting in placing the display directly over the control circuits, which are organized according to a matrix and will act directly on each pixel, no recourse to multiplexing being necessary. This should soon improve the characteristics of displays: resolution, image rate, visual quality and, why not, colors.

Research at the LETI is directed to three specific fields:

- TMOS matrices integrated into monocrystalline silicon (matrix design, bringing production outputs up to an adequate level, development of associated processes);

- thin-layer transistor devices (TCM) integrated into amorphous silicon (research on the physics of the component, matrix design, reliability);

- the new dichroic liquid-crystal mixtures that will make it possible to obtain visual qualities compatible with the display of color TV images.

Once these basic problems are under control, there will remain the problem of peripheral control. Why, then, not solve it with the same thin-layer process? This, at least, is what G. Labrunie is contemplating.

The Lannion CNET [National Center for Telecommunications Studies] is working in the same field, but from an angle that is intended to complement that of the LETI. A good example of coordinated... and successful collaboration.

Microelectronics: Collaboration With Thomson Semiconductors

The microelectronics laboratory is probably the most prestigious of its kind. It is the largest by the number of researchers (140), who are working in three distinct entities: semiconductor microelectronics, magnetic microelectronics, and general resources.

The laboratory recently moved into 6,000 m² of premises, right in the heart of the Grenoble nuclear center.

Already in 1982, it was clear that the experience and knowhow acquired by the LETI in microelectronics could not fail to tempt the leading domestic manufacturers. There are two of them: Matra-Harris Semiconductors (MHS) and Thomson Semiconductors.

Eventually, in February 1984, Thomson signed a protocol under which it became the privileged industrial partner of the LETI (although MHS is still collaborating with the LETI on certain projects). The protocol contained several important provisions:

- The executive direction of the partnership was entrusted to the LETI which was responsible for putting together and stabilizing its processing lines in its "technological" workshop, before transferring them to the production lines of Thomson Semiconductors.
- A "prototype" workshop was created at the LETI to produce in small series the advanced-technology integrated circuits developed by processes still in the research and development stage.

To understand better this collaboration, refer to the diagram which shows the nature and level of the various parties involved. It all starts with what J.P. Lazzari calls the basic LETI workshops, i.e. the groups working on research, ion implantation, plasma etching, etc.

When a process reaches a first level and when possibilities of industrialization can be foreseen, the process is entrusted to one of the LETI "technological" workshops which gives it a pre-industrial form. The process is then transmitted simultaneously to the volume production poles of Thomson Semiconductors (responsible for providing as soon as possible feedback on the implementation experiment) and to a prototype workshop consisting of 100-percent Thomson Semiconductors personnel.

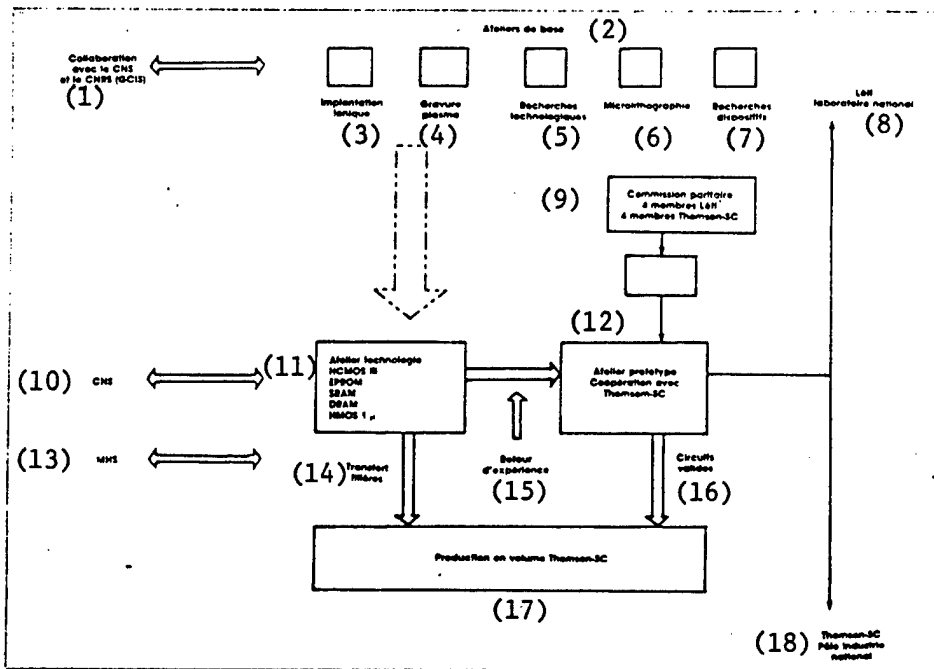

- Key:
1. Collaboration with the CNS [Norbert-Segard Center] and the CNRS [National Center for Scientific Research] (GCIS [expansion unknown]).
 2. Basic workshops
 3. Ion implantation
 4. Plasma etching
 5. Technological research
 6. Microlithography
 7. Research on devices
 8. LETI, national laboratory
 9. Joint commission: 4 membres from the LETI and 4 from Thomson Semiconductors
 10. CNS [Norbert-Segard Center]
 11. Technology workshop: HCMOS III, EPROM, SRAM, DRAM, 1-micron HMOS
 12. Prototype workshop - Cooperation with Thomson-Semiconductors
 13. MHS [Matra-Harris Semiconductors]
 14. Processing-line transfer
 15. Experience feedback
 16. Validated circuits
 17. Thomson Semiconductors' volume production

The prototype workshop is therefore the last stage prior to industrialization proper by Thomson (note, however, that Matra-Harris and CNS--the Norbert-Segard Center of the CNET--are not entirely excluded from the race... but maybe it only looks that way); from this organization, we should remember one essential point: the LETI, which retains its role as a research organization, is however not excluded from functional decisions.

Five Basic-Research Poles

The five basic workshops piloted by J.P. Lazzari are the launching ramps of all microelectronic activity at the LETI.

This is where it all begins. These five workshops cover homogeneously all the aspects of a circuit design and manufacturing:

- The ion implantation workshop has both a research and a service function. A research function because it is doing research on doping, diffusion, annealing and all phenomena associated to ion implantation. But also a service function, to the extent that it places itself at the disposal of the LETI as a whole, the CENG [Grenoble Nuclear Research Center] and even organizations outside the CEA.

Among the outstanding points of workshop research, we should note the solution found to the drain-source doping problem and for the realization of CMOS packages: implantation and furnace-annealing conditions (850°C, 30 minutes) were determined in order to obtain P/N junctions meeting the criteria of CMOS 1-micron circuits. Another successful trial was the evaluation of direct high-energy implantations.

- As for the plasma-etching technology workshop, it is working on the development of dry-etching processes applicable to the various materials used in VLSI (SiO₂, polycrystalline Si, silicides, aluminum and its compounds). This research has led to the development of industrial machines, which are then manufactured and marketed by CIT-Alcatel under the name GIR 200. An undeniable success, in France and in... Japan where many installations have been made.

Excellent results have been obtained with these materials:

- realization of trenches in massive silicon (5-6 micron wells in silicon, which are then filled with an insulator);
- pretreatment of the resin before plasma etching (because of the deterioration of the mask and the almost unavoidable loss of motives);
- etching on a double layer of niobium silicide/polycrystalline Si. Using an SF₆/C₁₂ mixture, it was possible to obtain a perfectly anisotropic etching and geometries smaller than one micron.
- improvement of etching-end detection sensitivity.

- The technological research workshop is very much production oriented. The fields covered involve oxidation (realization of oxides with increasingly small thickness grids); the material used, and in particular an original method to map the lifetime of minority carriers using an MOS capacitor (Si quality); the grid material, with research on NbSi₂ to obtain a low-resistivity material for a grid electrode; or again silicon on an insulator, with the application of laser-beam zone microfusion to a thin layer of silicon on oxide.

- The fourth workshop is devoted to microlithography, a field in which the LETI has obtained remarkable results (lines of 0.3 micron in the labo, using an optical process). The workshop is concentrating its efforts on optical masking (electronic masking being not considered as an end in itself, but rather as a research and development tool), the goal being the 0.6 micron barrier under industrial conditions.

Note in particular: research on masking resins (two-layer and three-layer resins), on the planarization of intermediate oxides, and on everything having to do with the quality of the industrial process (alignment, line quality, speed, proximity effects).

- Last workshop: the one called "research on devices." They are already talking about micron HMOS [high-performance MOS] and CMOS or submicron HMOS processes. This is where the processes of the future are taking shape: HCMOS III [high-capacity MOS] will be a 1.25-micron technology; it will use photorepetition on a wafer with multilayer resins, spacers in the middle of the grids and pseudo-planarization.

This was at the origin of HCMOS IV (0.8-1 micron), using sophisticated low temperature and optical processes. This is also where the HMOS and HCMOS 0.6-micron process (using new optical mixing and electron beam methods) and the SOI (silicon on insulator) process are being defined.

Magnetic Bubbles: Some Still Have Faith... The Josephson Effect and Data Processing: It's Over

Within the microelectronics laboratory of the LETI, a group of some 40 researchers headed by Mr Jouve is working in particular on magnetic microelectronics. In other words, on everything having to do with magnetic bubble memories, recording methods on electromechanical magnetic media, and on the Josephson effect.

A Trio for the Bubbles

In the field of bubble memories, the LETI is acting as a research laboratory for SAGEM [General Electricity and Mechanics Applications Company] for which it is implementing an already old plan of collaboration. We should note that the ground has already been well prepared upstream, for another sector of the LETI, that of materials (close to 100 people) is responsible precisely for the design and predevelopment of materials likely to be used later on in the bubble memory technology. These materials are manufactured by Crismatec, a joint subsidiary of Rhone-Poulenc System and the CEA.

There is no lack of examples: gadolinium gallate as a magnetic bubble memory substrate; substituted gadolinium gallate as a substrate for magnetic-optic films; thin epitaxial garnet layers (magnetic film for bubble memories), etc. Actually, the magnetic-bubble activity of the LETI must be considered as being part of a trio: the LETI for research, Crismatec for the production of materials, and SAGEM for their final integration into systems. The plan of collaboration with SAGEM provided roughly for two stages. The first, which is already a thing of the past, made it possible to make 1-Mbit and 4-Mbit 8-chip bubble memory packages in permalloy (traditional structure).

The second stage, i.e. the current stage, is characterized by a very different ion implantation process (the same process on which the U.S. Intel and the Japanese Hitachi are working). The first product should be completed in 1986 and would have a density of 4 Mbits per cm^2 . The second product will not appear before 1988/1989, but its density should be four times greater.

As far as electromechanical magnetic supports are concerned, the LETI is interested in a new recording technology, the so-called vertical technology as opposed to longitudinal recording (the magnetic dipoles created by the write head are placed perpendicularly to the surface of the support instead of being aligned along a track). This method offers many advantages: no demagnetization problems, prospects for very high linear and radial densities.

In this field, the LETI is a partner of Bull, one of the four French manufacturers interested in the subject (the others are SAGEM, Schlumberger for recorders, and Rhone-Poulenc Systems for floppy disks).

All this should yield industrial results in three to four years. At any rate, the 17 people working on it at the LETI "firmly believe" in it.

The Late Josephson Effect

In 1962, when the English engineer Josephson invented the effect that bears his name, augurs predicted that it would entirely alter the data-processing landscape. The LETI and... IBM were among them, dazzled as they were by its characteristics: switching energy of the order of the milliwatt, communication speeds of a few picoseconds. There was only one drawback: the circuit breaker had to be immersed in a liquid-helium bath... that's all. After that, it proved impossible to solve basic technological problems. IBM gave up and so did the LETI a little over one year ago, at least as far as pure data-processing applications are concerned. Otherwise, it still has faith in it, to make sensors.

9294
CSO: 3698/447

JPRS-WST-85-018
20 JUNE 1985

SCIENTIFIC AND INDUSTRIAL POLICY

OLIVETTI REPORTS FIRST HALF, 1984 RESULTS TO SHAREHOLDERS

Turin NOTIZIE OLIVETTI in Italian Oct 84 pp 3-6

[Text] On 14 September the Board of Directors of our Company met at Ivrea. During the meeting, the Company's semi-annual report to the CONSOB [National Commission for Companies and the Stock Exchange (Italian counterpart of the American Securities and Exchange Commission)] was discussed and approved, as was also the "letter" which the Board sends to the Company's shareholders and which we publish below.

During the first half of 1984, the Company and the Group achieved further growth with respect to the same period in 1983, both in terms of billings and orders and in terms of reinvestment. The subject period was further characterized by the introduction of important new products and market strategies, and especially by two capital increases that are significant to the growth of the Group and to an opening of a new type of relationship within the firm.

During this first half, the Company's billings totaled 999 billion lire, as compared with 860.9 billion lire during the same period of the preceding year, an increase of 138.1 billion lire (+16 percent). During the same period, consolidated billings for the Group totaled 1,879.9 billion lire, up 243.8 billion lire (+14.9 percent).

Orders received by the Company on the Italian market during the period amounted to 737.5 billion lire, up 120.1 billion lire (+19.4 percent) over the 617.4 billion total for the corresponding period of the preceding year. For the Group, orders totaled 2,113.5 billion lire (+19.5 percent).

The Company earned a gross profit of 444.7 billion lire in the first 6 months of 1984, as compared with 394.9 billion lire during the first half of 1983, for an increase of 49.8 billion lire (+12.6 percent). The Company's net worth as of 30 June 1984, excluding the results of the period, attained 1,601.7 billion lire, up 522.6 billion lire over that as of 31 December 1983.

Rise of Billings
(Billions of Lire - to 31 December 1983)

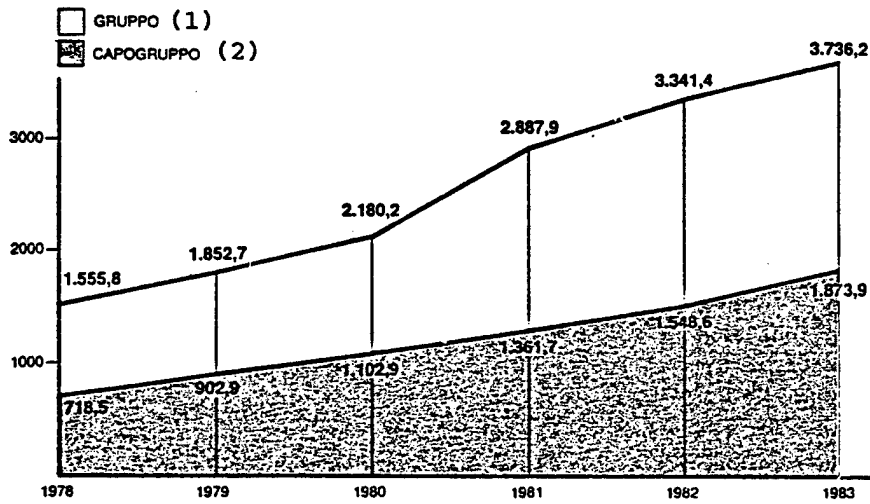

Key:

1. Group.
2. Group's Leading Company [Olivetti].

These results are particularly significant considering that the dismal world situation as regards the scarcity of electronic components may induce a critical shortfall of billings during the second half, owing to supply difficulties. Furthermore, the sharp rise in prices of components, which the market makes it impossible to recover in the prices of the finished prices, may make it extremely difficult, during the second half, to maintain the profit margins achieved to date.

The positive results in billings and orders during the first half reflect the growing valuation the market is placing on the products the Company is commercializing, on the new products it has announced, and on its planned market strategies.

Significant in this respect is the increase in orders for systems products (+31.5 percent on the Italian market). This is directly related to the announcements made at the Hannover Exposition and on other important occasions. The announcement of the new line of personal computers and 3B mini-computers--of A T & T origin--aroused great interest and represents the expression of the Company's strategic commitment to this market, which is characterized by a high degree of dynamism in the technologies and in the distributive structures.

Olivetti's new line of PC's includes the desk-top Model M24 and the portable Model M21 with built-in video. Its new products, featuring a high degree of systems flexibility, offer the user full compatibility with the standards on the market, enabling the user to take advantage of the vast library of applications programs that has been developed in recent years.

The marked interest aroused by the announcement of the M21 and M24 on the European market has translated not only into a substantial flow of orders but, above all, into an impressive number of distributors with a high marketing potential, who constitute the decisive element in the commercial strategy for this type of equipment. In this context, other events of considerable importance have been the conferences Olivetti has organized in France and Great Britain, at which the most recent developments in the L1 minicomputer line, and an overview of information-processing solutions being offered by the Company to the various categories of business users, have been presented to the press and to major-users in the various sectors.

The basic principle of the new strategy behind these offerings is that different work stations, such as personal computers, terminals, and electronic writing systems, are made capable of communicating with each other and with other systems, and of exchanging data, text and information, thus realizing multifunctional systems, able, that is, to perform other activities, including the accessing of data banks and telematics service, and to connect up with data processing centers.

This Olivetti supply strategy is articulated in diverse ways, depending on the size of the user, with characteristics peculiar to the big user on the one hand, and to the small- and medium-sized user on the other.

With regard to big users, the strategy is characterized by a new overall concept of integrated information systems, called the "Olivetti Integrated System Environment," consisting of products (hardware, software communications and integration systems) that are compatible, even insofar as concerns their future development, with international standards.

The offering is supplemented by the availability, alongside the basic workstation line, also of specialized products for specific categories of application, such as terminals for automation of points of sale, industrial terminals, bank terminals of various types, including self-service, and automated teller windows.

The offering for the small- and medium-sized business market, on the other hand, is characterized by the new concept of "multifunctionality," which seeks to provide an overall and integrated response to all the demands of the user, via the availability of the various models of computer of the L1 line, complete with the new M60, at the top of the line.

As for the often-stated developmental policy line, centered on its internal technological capabilities and those of the Olivetti market, as well as on external acquisitions by way of investments and major strategic alliances, Olivetti deems it has built the bases for a world-scale competitive capability, as demonstrated by the first half-year's results.

During the first half of 1984, the alliance pact signed with A T & T in December 1983 was implemented, with the entry of A T & T as an Olivetti shareholder. On 14 March 1984, the special shareholders meeting voted the issue of 100 million common shares to be reserved to A T & T at a price of 4,300 lire each, of which 3,300 lire represented a surcharge, for a total of 430 billion lire. A second capital increase consisted of an offering of 20 million nonconvertible savings shares to Olivetti employees at 1,500 lire per share, of which 500 lire represented a surcharge. This offering resulted in subscriptions to 10,879,800 shares by 10,697 employees, for a total of 16.3 billion lire, including the surcharge. The remaining shares will be offered to employees on terms that are in the process of being defined.

Pursuant to the payments into capital resulting from these operations, the Company's financial position as of 30 June 1984 amounted to a net balance of 61.4 billion lire in liquid assets versus a net indebtedness of 186.5 billion lire as of 31 December 1983 and 282.7 billion lire as of 30 June 1983. This situation, an unquestionably exceptional one for a European industrial group, enabled the elimination of financial charges, resulting instead in a net positive balance of 3.2 billion lire in cash receipts.

The increase in billings, the consequent increase in gross profits, and the savings obtained with regard to financial charges, despite the sharp rise in marketing, structural and research costs, resulted in a substantial increase in reinvestment. Roughly speaking, taxes on income rose from 144.2 billion lire for the first half of 1983 to 174.4 billion for the January-June period

Shareholdings in Group's Leading Company [Olivetti]
(as of 31 July 1984)

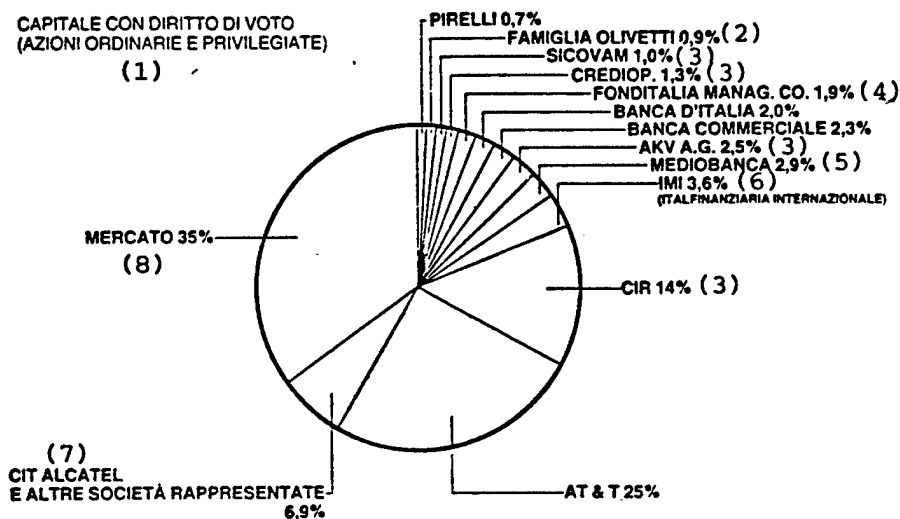

Key:

1. Capital Voting Shares (Common and Preferred Stock).
2. Olivetti Family.
3. [expansion unknown].
4. Fonditalia Management Company.
5. Financial Credit Bank.
6. Italian Credit Institute.
7. CIT-Alcatel [French] and other representative companies.
8. Open market.

of 1984 (+20.9 percent), with its ratio to billings rising from 16.8 percent for the first half of 1983 to 17.5 percent for the first half of 1984.

A more detailed analysis of the increase in the billings of the Group's leading company [Olivetti] shows that 639.1 billion lire of the total (+14.8 percent with respect to the first half of 1983) was accounted for by the Italian market and 359.9 billion lire (+18.3 percent) by foreign markets.

The European area accounted for 62 percent of our exports (as in the first half of 1983), Africa and Asia 15 percent (18 percent in 1983), North America 20 percent (17 percent in 1983) and Latin America 3 percent (as in 1983). The growth in exports to the United States is owing in part to the start of supplies to A T & T (20.2 billion lire as of the end of June), whereas the drop in exports to African and Asian areas is owing to the difficult economic and financial situation of those markets.

The mentioned sales to A T & T represent the initial and immediate result of our alliance with A T & T, and demonstrate the validity of the agreements and the opportunities thus immediately opened to Olivetti. They represent the first shipments under the multi-year agreement, which provides for Olivetti billings to A T & T, during the 9-month period April-December 1984, totaling \$250 million and involving a model of PC totally designed and produced in Olivetti establishments.

An agreement of this scope, which necessitated a significant and exceptional increase in the Company's productive capacity within an extremely short period of time, required a large-scale commitment in terms of investments in equipment and manpower. Such a commitment--which could not possibly have been justified within the limits of a one-time supply operation, considerable though it was--is in fact justified as but the first result of a joint Olivetti-A T & T strategy which both partners have decided must be developed over a period of time.

The first half of 1984 also saw the continuation of Olivetti's growing commitment to research, with an expenditure during the first half totaling 78.1 billion lire, up 15.3 billion lire (+24.4 percent) over the first 6 months of 1983.

The Company's management team is committed to the carrying out of advanced research programs, technological realizations and innovations such as are also eligible for funding under the research categories financed by the IMI [Italian Credit Institute] and under the programs of the FIT [Technological Innovation Fund]. Under the first of these two recourses, 20 billion lire were received in March in the form of easy-term loans for the financing of the Company's research program pertaining to the period 1981-1985.

With regard to employment, the total number of Company employees went from 17,351 as of the end of 1983 to 17,208 as of 30 June 1984. This reduction of 143 persons during the first half of 1984 represents the difference

between 341 terminations (203 of which were early retirements), 144 transfers to subsidiaries, and 342 new hirings.

The new personnel hirings were channeled mainly into research, marketing and technical assistance activities, in keeping with the Company's development programs.

Development of the Company's productive capacity, particularly as a consequence of its supply agreement with A T & T, produced growth also in its production-sector employment levels. In fact, Company employees temporarily laid off with benefits under the Wage Supplement Fund, totaling 487 as of the beginning of the year, totaled only 168 as of 30 June. In addition, a new hiring program is being implemented for the assembly areas, with respect to personnel, including blue-collar workers, with specializations in the electronics field, or with the required academic schooling and at least specific aptitudes [for training] in the new technologies.

9399

CSO: 3698/428

JPRS-WST-85-018
20 JUNE 1985

SCIENTIFIC AND INDUSTRIAL POLICY

OLIVETTI ACQUIRES 49.3 PERCENT OF BRITISH ACORN

Milan L'INFORMATICA in Italian Feb 85 p 4

[Text] Olivetti's acquisition and participation strategy has scored another "coup": The acquisition of 49.3 percent of the British Acorn Computer company, which specializes in systems for educational activities. As disclosed in a press release from Ivrea [location of Olivetti headquarters], the acquisition resulted "from a capital increase of 12.1 million pounds sterling, 10.39 million of which was reserved for Olivetti."

Hermann Hauser and Christopher Curry, the founders of Acorn, commented that "Olivetti, as a strong international partner, will be able to bring to Acorn a presence in world markets. The success we have already attained in the United Kingdom will enable us to carry out new initiatives in the education sector."

For Ivrea, this is quite an important acquisition from the technological standpoint, since Acorn has a research and development laboratory at Cambridge from which new products could emerge. From a commercial standpoint, it has interesting business possibilities, in that the British firm accounts for almost 80 percent of the PC's installed in British schools.

Elserino Piol commented that "Olivetti has always considered the education market to be an important pillar of its strategy, in that it conditions the development of the market in which the firm operates. The educational systems of sectors will more and more be tied to the use of the computer, whether it be for the acquisition of basic scholastic knowledge, or for the training of a bank employee or an assembly line worker.

Acorn's best-known product is the BBC computer, which it developed jointly with the British TV network of that name and which represents the educational standard in Great Britain.

To date, the Ivrea-based group has invested in some 30 companies, particularly American and Japanese, with positive results thus far in most cases.

9399

CSO: 3698/428

JPRS-WST-85-018
20 JUNE 1985

SCIENTIFIC AND INDUSTRIAL POLICY

R M

NEW MAX-PLANCK RESEARCH CENTERS IN FRG 1985 BUDGET

Bern TECHNISCHE RUNDSCHAU in German 22 Jan 85 pp 64-65

[Article: "Structural Change in German Research Policy"]

[Text] The Federal German Ministry for Research and Technology has a respectable billion DM budget for 1985. While it increased by only 2 percent compared to 1984, its total amount is almost DM 7.2 billion, unless changes are made as a result of future discussions in the budget committee. In accordance with this budget proposal, fundamental research receives the most funding. This budget item accounts for approximately DM 2.4 billion or about 33 percent of the overall budget. The Max-Planck research center will receive more than DM 407 million. The technically oriented Fraunhofer research center which is responsible for applied research can expect approximately DM 114 million.

Taking Minister Dr Heinz Riesenhuber's and the Bonn government's intentions into account, the budget is to reflect the desired gradual shift from formerly used direct project subsidies to a more general, indirect subsidy policy. When examining the recently presented budget proposals providing for subsidies allocated to specific working areas, however, this is difficult to see for outsiders. The budget for the Max-Planck research center, for example, includes the construction of two new research institutes: In the area of laser research, an institute for quantum optics, i.e., laser research, will be built in Garching near Munich, and an institute for polymer research will be established in Mainz. A remarkable DM 44 million were allocated to the Hadron-Elektron-Ring Facility (HERA) and the German Electron-Synchrotron (DESY) to be better able to defend the international reputation in fundamental physics research.

After extended hesitation the deep drilling program in the Federal Republic which was initially conceived in the 60s and 70s is to finally get under way. Almost DM 18 million have now been allocated to the geosciences for this purpose. In contrast thereto the resources research was cut by more than 50 percent to a figure just short of DM 50 million. The development edge gained in the areas of information science and microelectronics is gradually diminishing. However, over DM 500 million have yet to be provided.

Considerable sums have been budgeted for space research (DM 810 million) and for environmental research (some DM 137 million). In order to facilitate

research and development in smaller and medium-sized companies, DM 55 million have been allocated for staff subsidies.

The spectrum and scope of research and development thus funded have impressed Americans as well as Japanese. The European neighbors are even somewhat jealous of the Federal Republic, suspecting these support funds to be hidden subsidies to industry which would distort competition within the EEC.

9544

CSO: 3698/408

WAYS TO IMPROVE FRG VENTURE CAPITAL CLIMATE STUDIED

Aarau ELEKTRONIKER in German Jan 1985 pp 15, 17, 19

[Article by Dr Walther Konhaeuser and Dipl-Ing Hubert Pratschke: "Venture Capital to Finance Innovative High-Technology Companies"]

[Excerpts] The conversion of inventions into series-manufactured products and the application of new industrial technologies is very cost-intensive. For inventors and high-technology companies, venture capital is a new way of financing the expansion of existing or the establishment of new companies. Below you will find an explanation of the term venture capital financing and how venture capital financing can be implemented. The paper describes forms of venture capital financing available in the Federal Republic. It is geared to those readers who are contemplating establishing a business in the electrical engineering industry.

1. Introduction

The Federal Republic of Germany is one of the leading industrial nations worldwide. If this level is to be retained, new technologies, e.g., microelectronics, information and communication sciences, sensor technology, automation technology, laser technology, material technology and bioengineering have to be promoted as major targets and expanded. The direct subsidies initiated by the Federal German Ministry of Technology, e.g., the special subsidy program entitled "Application of Microelectronics" with a budget of DM 450 million, are first steps which must be followed up on by further activities and a broad basis.

In the FRG there is no lack of people having innovative technological ideas who are willing to assume entrepreneurial risks; there is a lack, however, of daring and competent investors so that many ideas and projects do not even reach a stage where economic utilization can be realized. The banks consider high-technology clients difficult to evaluate. On the one hand, banks cannot undertake major direct technology financing because nowadays the firms usually have less than 5 percent equity. On the other hand, the time involved bears no relationship to the prospective business volume.

The capital required by fledgling innovative high-technology firms to expand their activities is only scarcely available, thus bringing about the danger that the FRG might lose its position in high technology since most of the innovative inventions of the last decades were not made by established corporations. In order to deal with this problem effectively, actions are required which go far beyond the subsidies offered by the Federal German Ministry of Research and Technology.

The current venture capital situation, as is evident in the FRG today, can be best described using a diagram. Venture capital can be subdivided into direct and indirect investment. Direct investment by individuals or organizations does exist; however, it is economically insignificant. In the case of indirect investments, the investor and the borrower are linked by an institute. So far, venture capital investment in the FRG has been concentrated on project-oriented financing, which is more risky for the investor, however. But the risk decreases if the investor pays his money into a fund which makes several investments, thus spreading the risk. In the future, successful venture capital investment then will be in fund-oriented investment.

4. Summary and Outlook

In the FRG adequate opportunities exist for innovative investment; there is also a demand for investment opportunities. However, a climate has yet to be created successfully linking both partners, the investor and the high-technology firm. Above all, three major objectives should be pursued since they are the basis for successful implementation of venture capital financing:

- Ready-for-investment venture capital has to be activated.
- Qualified management completely knowledgeable in the venture capital business must be available for a successful implementation of venture capital financing (venture capital managers are presently scarce in the FRG).
- Via a functioning stock exchange the venture capital company must have a way out of the investment.

Additional improvements to be sought in order to nurture capital financing in the FRG are as follows:

- Continued direct governmental subsidies, particularly for small and medium-sized companies.
- Indirect activities, particularly tax benefits for the venture capital company, the investor, as well as for the innovative company.
- Decrease of laws and regulations standing in the way of establishing innovative companies. It is up to the legislature to make this easier.

Independent of that, the private sector can implement successful venture capital financing by establishing venture capital companies, investing in high-technology companies and establishing specialized investment banks

which will then encourage further venture capital activities. In conclusion, we would like to make one additional remark: Neither the demands of the trade unions to cut the working week nor the investments made by established corporations are suitable to create a sufficient number of new jobs on a long-term basis which will markedly improve the unemployment problem in the Federal Republic. A better solution, in our opinion, is the concentrated support of innovative technology which will create new jobs in small, successful companies.

9544

CSO: 3698/408

SCIENTIFIC AND INDUSTRIAL POLICY

CIBA-GEIGY 1983, 1984 EARNINGS BY BRANCH

Zurich CHEMISCHE RUNDSCHAU in German 18 Jan 85 p 1

[Article: "Ciba-Geigy: Increased Sales"]

[Text] eb. Ciba-Geigy announced the turnover figures for the past year: for the entire company sales amounting to Fr 17.48 billion were achieved which represents an increase of 19 percent compared with 1983.

According to data supplied by the company this almost entirely quantitative enhancement of sales also augurs a marked improvement in profits. As early as 1983 the company had achieved a profit increase of 24.8 percent, obtaining a companywide figure of Fr 776 million.

Sales by Divisions and Groups

<u>Divisions and Groups</u>	<u>In Billions of Francs</u>		<u>Increase in %</u>
	<u>1983</u>	<u>1984</u>	
Dyes and chemicals	2.20	2.41	+10
Pharmaceuticals	4.42	5.06	+14
Agricultural	3.58	4.59	+28
Plastics and additives	2.93	3.61	+23
Airwick	0.68	0.74	+ 9
Ilford	0.44	0.50	+12
Electronic equipment	<u>0.48</u>	<u>0.57</u>	<u>+18</u>
Company total	14.74	17.48	+19

According to the company all its divisions participated in the sales increases. With the exception of the American market, the dyes and chemicals division profited from the good competitive situation. The pharmaceuticals division was able to maintain its market share and its sales correspond to the growth by 14 percent in the worldwide pharmaceutical market. The lifting of restrictions on agriculture in the United States as well as the increased demand in various countries for insecticides and for seeds stimulated sales in the agricultural division. A 23-percent increase in sales was also achieved by the plastics and additives division. The Airwick group which was recently taken over by the British company Reckitt and Colman participated at a rate of 4 percent in the total sales of the Basel company.

8008

CSO: 3698/409

JPRS-WST-85-018
20 JUNE 1985

SCIENTIFIC AND INDUSTRIAL POLICY

USE OF LOSS CARRYBACK IN FRG INCOME TAXES

Munich INDUSTRIEMAGAZIN in German Apr 85 pp 186-87

Article by Michale F. Raubal, a partner of Doctors' Trust Administration, GmbH, of Berlin: "A Dodge for Top Earners"

Text Now as before, the provisions of para 10d of the Income Tax Code (EStG), and particularly the creative possibilities that a purposeful application yield, remain largely unknown or ignored, even among members of the tax-counseling professions. Hence, this particular paragraph is of especially great interest to all those higher earners who are burdened by progressive taxation.

Para 10d states that losses totalling up to DM5 million, which are not offset when computing the total amount of earnings, can be deducted as special expenses from the total amount of earnings in the second assessment period preceeding the assessment period. To the extent that a deduction cannot be made in this manner, the losses can be deducted as special expenses from the total amount of revenues in the first period preceeding the assessment period.

This sounds more complicated than it actually is. So, we will make it clearer with an example:

A entrepreneur expects to earn DM250,000 in 1985. He has just received his income tax bill for 1983. For 1983, his taxable income comes to DM225,000. And for 1984, he knows, his income will be roughly as high.

Our entrepreneur will have to make a considerable back payment for 1983, if he does not succeed in further legally reducing his income.

The solution: an investment with high paper losses in 1985. If, for example, he enters into a builder-owner company that builds publicly funded housing in Berlin and that realizes high paper losses with the high special depreciations specified in para 14a of the Berlin Assistance Act (Berlin-FG), then he can "carryback" any losses arising in 1985, as long as they exceed his income for 1985, to 1983. With expected earnings of DM250,000 in 1985 and paper losses of DM350,000 from his investment (assuming a Berlin investment of DM600,000), DM100,000 could be carried back to 1983 and his taxable income for 1983 would be reduced from DM225,000 to 125,000, which--according to the basic table--would result in a income tax savings of at least 56,000 marks for a single person.

If a paper loss of DM500,000 (from an investment of around DM850,000) in 1985 is indicated for this person, then the Tax Bureau would officially proceed as follows: DM250,000 in losses that could not be offset will be carried back to 1983, reducing the taxable income for 1983 (like that for 1985 already) to zero, so that 25,000 marks in losses that cannot be offset remain, which will then be deducted from the income for 1984.

If the losses that could not be offset were so high that they also exceeded the income for 1984, then they could be carried forward for the next 5 years.

Moreover, these possibilities can also be used by self-employed people and employees. Here, the desired effect can be increased by a sensibly directed structuring of income in 1985.

The entrepreneurial possibilities for the profits tax beyond the balance sheet are sufficiently well known. The self-employed have similar possibilities with the 1985 change in the method of reporting profits (from balance sheet to computing the surplus or vice versa), and even employees can, within certain limits, control their earnings from nonindependent work by arranging a somewhat later payment time for components related to sales and receipts.

One thing cannot be overlooked: The loss carryback means that in the years in which losses are higher than earnings more lightly taxed income brackets will be met and, moreover, the benefit of tax allowances will be lost in these years. For the really top incomes, however, which we can settle on here as starting at more than DM250,000 per year, this effect can be ignored, since the positive effects outweigh it by far.

The particular advantage in this, for one thing, is that taxes which have already been paid and for which there otherwise are definitely no possibilities of retrieval, can be transformed into assets. And, for another thing, that an improved liquidity is realized since payments to the company one has a share in to not have to be made until 1985 and, moreover, backflows from the previous years and possibly some prepayment sums from the current year that do not have to be paid will be at one's disposal.

A prerequisite, however, of using the loss carryback is that there must actually be a loss in 1985. Sums of the necessary size can be achieved in different ways: through investing in ships, investments in the area bordering the GDR and in Berlin, to name just the most important categories. Alternatively, participation in the builder-owner, building-contractor and purchaser models also comes under consideration, with all their long known advantages, but also with risks, such as the so-called restoration model in the real estate sector, where investments with special depreciations for landmark preservation deserve some attention.

12507

CSO: 3698/421

SCIENTIFIC AND INDUSTRIAL POLICY

EC TO PROMOTE HIGH-TECH RESEARCH COOPERATION WITH 'BRITE'

Zurich CHEMISCHE RUNDSCHAU in German 18 Jan 85 p 1

[Article: "Intensive Support by the Common Market: Basic Research"]

[Text] The European Common Market is intensifying the reorientation of its research and technology policy. It is planned that now frontier technological developments will be already promoted on the front lines of competition with the aid of strategic research programs. With this new strategy the Common Market Commission is putting to use positive results obtained in Japan. It has been shown that competing enterprises can cooperate very well in technological basic developments while later going their separate ways in the subsequent phase of competition. The EEC research programs link together national research facilities and are oriented toward economic-strategic goals. This is the aim in particular of the 4-year EEC program called BRITE (BRITE = Basic Research in Industrial Technologies for Europe) which is to start in mid-1985. The EEC Commission expects to provide DM 380 million in order to support pioneering cooperative projects on the front lines of competition. The commission will participate in 50 percent of the project costs. Since the first announcement of this project there have been around 3,000 expressions of interest.

In the preparatory phase hundreds of Common Market countries were asked what areas of industrial research and development they considered to be especially important. Approximately 700 proposals were submitted and on the basis of these 9 technological areas were selected as being of primary importance: reliability, wear and deterioration; laser technology and powder metallurgy; communications technology; new testing procedures (both on-line and computer-aided); CAD/CAM and mathematical modeling; polymers, bonding materials and new materials; membrane science and membrane technology; catalysis and particle technology and new production technologies for products made of flexible material.

The peculiarity of this EEC program consists in the fact that it does not make products but rather "preproducts" (technologies). These are created as new fundamental engineering solutions to some specific technical problem in order then to subsequently yield advantages in a product or process. However, this second phase of adaptation development is no further pursued in the program because it now lies on the competitive plane. Since new technical fundamental solutions, that is to say new technologies, are applicable to many similar problems and may be considered multifunctional the results which may be expected of this program have an inestimable breadth of usefulness.

FRG GOVERNMENT MEASURES TO FURTHER CIVIL R&D DETAILED

Frankfurt/Main FRANKFURTER ZEITUNG/BLICK DURCH DIE WIRTSCHAFT in German 8 Mar 85 p 4

[Article: "Increase Private Initiative in Research. Small and Medium-Sized Firms Also Said To Profit From Assistance"]

[Text] (DUS) Frankfurt--Research and innovation are indispensable for economic growth and employment in the FRG. Increased division of labor all over the world, which is additionally influenced by obligatory technology funding in various countries, requires that the FRG economy, in using new technologies, continue with even greater emphasis than before to develop a technically advanced, competitive supply of goods and to employ corresponding cost-effective production methods. The research, development and economic use of forward-looking technologies is an important prerequisite. The comparative competitive advantages arising out of such work improve export potential, growth and employment.

Federal assistance for research, development and innovation is decided upon by the federal government in accordance with a concept of "role distribution" which applies to both the private sector on the one hand and the state on the other in a socialist market economy. According to our economic order, industrial research, development and innovation originate with the enterprises. Therefore, all federal assistance for research, development and innovation supplied to trade and industry is in the form of subsidies. The primary objective is to strengthen private initiative in the enterprises and the driving forces within the market.

I. Federal Assistance for Research and Development in Trade and Industry. [in italics] In 1983 about DM 46.8 billion were spent for research and development in the FRG of which DM 31.6 billion, or 67 percent, went to trade and industry. Trade and industry itself financed 18 percent, or DM 25.6 billion, of its R&D expenditures. Taking into account that the DM 31.6 billion spent by trade and industry on R&D includes DM 1.4 billion for military R&D requested by the state alone, DM 30.2 billion were spent for civil R&D. The federal government financed R&D in trade and industry amounting to a total of about DM 5 billion.

Table 1 Federal Assistance of Civil Research and Development from 1982-1985 in Millions of DM

Type of Assistance	1982	1983	1984	1985 ¹⁾
1. Total assistance				
Trade and industry, not including SNR ²⁾ and THTR ³⁾	3.408 (100%)	3.275 (100%)	3.433 (100%)	3.700 (100%)
Categories:				
1.1 Indirect and indirect-specific assistance	790 (23%)	1.046 (32%)	1.233 (36%)	1.500 (41%)
1.2 Direct project assistance by BMFT (not including SNR and THTR). . .	2.116 (62%)	1.811 (55%)	1.700 (50%)	1.600 (43%)

- 1) estimated
- 2) boiling water low pressure reactor
- 3) thorium high-temperature reactor

The distribution of people employed in R&D corresponds to the distribution of funds for research. Of the total 370,000 people employed in research in 1981, 65 percent were in trade and industry. Of this total, on the other hand, not even one third are scientists; 30.1 percent are technical personnel and the rest are support personnel. The scope of federal research assistance is described below:

1. Federal Expenditures for R&D in Trade and Industry in the FRG. [in italics] Federal research grants to trade and industry in the FRG primarily involve:

- defense-related research amounting to approximately DM 1.4 billion in 1983, or 4.4 percent of the research money going to trade and industry
- assistance for civil R&D amounting to about 15 percent of total research funds going to trade and industry. Here again federal assistance primarily involves government programs. Contributions by the federal government and by sources outside the FRG (largely through international organizations) amount to 87 percent of federal research assistance.

We will concentrate below on federal assistance efforts in behalf of civil R&D because defense-related research is a special responsibility of the state, and within the past few years in particular a number of defense-related R&D assistance programs emphasizing consultation have been developed. Details concerning the activities of the FRG Laender can be found in Research Report VII released by the FRG government in 1984. Due to its predominance in terms of assistance for research and also in view of its legislative activities, particularly in the area of tax law, the federal government of the FRG is given top priority in the discussion which follows.

2. Federal Research Assistance. [in italics] In 1983, the approximately DM 31.6 billion in expenditures for research in trade and industry comprised:

- DM 25.6 billion in private financing by trade and industry
- DM 1.4 billion in federal funds for defense-related research
- DM 3.9 billion in federal funds for civil R&D
- DM 0.4 billion in assistance from the Laender
- DM 0.4 billion from other sources, in particular those outside the FRG

Federal support to trade and industry concentrates on tax incentives as well as on indirect assistance in which R&D activities in general are supported and in which the state is not involved according to the strict definition of the individual projects. Of the nearly DM 12 billion in federal R&D expenditures made in 1983, about 44 percent went to general trade and industry, including defense-related research. The federal government spent about DM 10 billion on civil R&D. Of this figure about 39 percent went to commercial enterprises.

There are currently two very important tax incentives which apply to R&D in trade and industry:

- the R&D allowance in accordance with Paragraph 4 of the Investment Allowance Act which results in tax revenue losses of approximately DM 350 million annually
- special depreciations for R&D which have been in force since 1983 and which are expected to result in about DM 400 million in reduced tax revenues in 1985.

Both of these tax measures have a so-called small-business component, i.e. small and medium-sized firms receive an additional benefit. Combining the two tax incentive measures clearly facilitates the making of research investments, particularly when they are spread out over several years. The tax laws regarding special depreciations and investment allowances are well coordinated and complement one another. In addition to these tax incentives for R&D activities, the direct goal of which is an increase in R&D results, there are some other tax incentives which serve to increase demand for technology-related products. These incentives include:

- the investment allowance in the field of energy production and distribution as per Paragraph 4 of the Investment Allowance Act
- increased deductions for products related to environmental protection as per Paragraph 7d of the Income Tax Act
- increased deductions for the production costs of systems which use regenerated energy and systems for more efficient energy consumption as per Paragraph 51 of the Income Tax Act in conjunction with Paragraph 82a of the Income Tax Implementing Ordinance.

Altogether, these tax incentives which stimulate demand for technology-related products led to reduced tax revenues amounting to about DM 700 million in 1984.

The following indirect assistance programs are financed by the federal government:

- the program of assistance for R&D personnel in trade and industry 1985-1988
- assistance for contract R&D, which was expanded in scope in 1984.

Both types of assistance are overseen by the Working Group of Industrial Research Associations (AIF) under contract to the federal government. Due to a directive issued by the EC Commission on February 21, 1985, this FRG government program has now been halted. The EC Commission has initiated proceedings in accordance with Paragraph 93 of the EEC Agreement to determine whether this assistance is in compliance with the code of fair competition of the Common Market. Therefore, no new applications of any kind are being accepted for this program at this time. The federal government expects the matter to be resolved by July 1985, however certain modifications to the programs will be made. In any case it can be assumed that assistance for increasing the number of R&D personnel will continue. Further details can be obtained from the AIF in Cologne.

The instrument of indirect-specific assistance for research has evolved within the past few years in particular as a result of criticism of federal support of projects in the civil sector. Indirect-specific assistance involves the promotion of research, development and innovation in a specific technological field using a procedure similar to the indirect assistance method. These programs include:

- the special microelectronics program involving assistance for special applications which concluded in 1984
- the production engineering program which began in 1984 and which will run to 1988
- assistance for microelectronics (sensors) which begins in 1985.

About DM 2.9 billion was spent by the federal government for direct assistance to civil R&D in commercial businesses in 1984, of which DM 2.4 billion came through the Federal Ministry for Research and Technology (BMFT). In 1982 these funds amounted to about DM 3.6 billion of which about 3.1 billion were from the BMFT. The BMFT thus administers about 85 percent of the state's research-related resources for project assistance. The other 15 percent is divided among various departments, of which the Economics Ministry has a large share. In the past BMFT assistance for these projects was criticized. However, the special circumstances involved in BMFT assistance to projects must be taken into account.

This has clearly resulted in a high concentration in the area of energy research for which about 60 percent of the funds are being used. In 1982 a high point was reached due to the supplementary budget which was necessary in order to ensure financing of the state-of-the-art SNR and THTR reactors. Otherwise,

[Table] BMFT assistance for projects in trade and industry is broken down as follows:

Sector	1982 millions of DM	1983 millions of DM
1. Energy research, not including nuclear reactors	908.7	802.8
2. SNR and THTR nuclear reactors	1027.0	669.8
3. Transport and traffic	249.6	217.0
4. Space research	206.2	166.0
5. Information technology	187.8	174.9
6. Procurement of raw materials	128.5	107.9
7. Humanizing the working world	67.9	56.1
8. Aeronautics research	68.5	63.4
9. Environmental research	60.9	43.5
10. Other	237.8	179.1
Total including reactors	3142.9	2479.5
Total not including reactors	2115.9	1810.7

however, project assistance by the BMFT in trade and industry is concentrated in precisely those areas which constitute national interests. For example:

- Transport and traffic
- Space research
- Procurement of raw materials
- Aeronautics research
- Environmental research

These are areas which as a rule cannot be covered by private initiative alone. The objective of research policy--particularly for the new federal government in power--is to concentrate assistance for projects in the civil sector on basic technologies. Broad applications of research in trade and industry are furthered by:

- tax incentives
- indirect assistance for research in which the state does not select the projects
- indirect-specific assistance in special areas of technology

Tax incentives, indirect and indirect-specific assistance for research, and project assistance are the essential instruments of state research assistance. For a summary of federal assistance for the period 1982/1983, see the large table.

A revision of research assistance policy was initiated by the Economics Ministry as early as the latter part of the 1970's. Since the fall of 1982 increased efforts in this regard have been continued at an increased pace by the new government. Table 1 shows federal assistance for civil research for the years 1982 to 1985.

Table 2. Assistance for Small and Medium-Sized Businesses From 1982-1985 in Millions of DM

Type of Assistance	1982	1983	1984	1985*
1. Total assistance to trade and industry not including tax incentives	4.152	3.454	3.433	3.600
1.1 Not including SNR and THTR	3.125	2.885	2.733	3.000
2. Small and medium-sized businesses . .	824	802	760	940
In percent	26.4	27.8	27.8	31.3

* estimated

The table shows the clear increase in direct and indirect-specific assistance which nearly doubled between 1982 and 1985. At the same time direct project assistance from the BMFT has declined by about DM 500 million. The trend is increasingly toward broadly applied indirect research assistance, primarily by means of:

- special depreciations for R&D
- increasing the personnel cost subsidy by the amount of the subsidy for R&D personnel as of 1985 (BMFT)
- increased assistance for contract R&D
- indirect-specific programs in production engineering and microperipherals

These measures have led to a decrease in the percentage of project assistance for civil R&D not including the reactors from 62 percent in 1982 to 50 percent in 1984, and is expected to be about 43 percent in 1985. On the other hand, the small and medium-sized businesses in particular have benefitted from broadly applied indirect assistance. As Table 2 shows, the amount of assistance to trade and industry which these businesses received increased to over 30 percent.

In summary it can be said that one of every two marks spent by the federal government for civil R&D in trade and industry is no longer applied as assistance for specific projects, but rather is in the form of indirect measures including tax incentives. In these calculations the resources for the large-scale SNR and THTR projects are not included because they can of course only be financed by means of project-related assistance. What is significant is the greater concentration on assistance for projects involving basic technologies in civil R&D and the increased importance of indirect research assistance.

Table: Instruments of R&D Assistance to Trade and Industry
 A Synopsis--Status: 10 Oct 1984

Instrument of assistance/features	Project funding as per BKFT 75	Production engineering-- indirect-specific measures (1 January 1984 - 31 December 1987)	Businesses involved in production engineering for either or
Authorized applicant	Company engaged in trade or industry		
Requirements for funding	Project can be classified under existing BMFT program; sufficient company capital on hand	Introduction of CAD/CAM	Development of industrial robots, manipulating systems or related intelligent peripherals
Technical appraisal by panel of experts	As a rule yes		no
Evaluation basis	A) Material and fixed costs B) R&D 3rd party services and fixed costs C) Wages, salaries and fixed costs D) Special expenses - special operating funds - special equipment - depreciation of special systems - computer expenses - travel expenses - other special expenses E) Accounting costs - interest - depreciation - business services F) Fixed adminis. costs G) Costs of unspecified R&D	Hardware and software - R&D 3rd party services - Technical consulting by 3rd parties - Employee training - Grad. engineers, etc. DM 11,000/man-month - Technicians, etc. DM 8500/man-month - Skilled workers DM 600/man month Ancillary costs and fixed costs covered by above flat amounts	Materials and purchased parts
Amount of assistance	As a rule, 50% of project-related costs		40%
Maximum limit	-	Max. DM 400,000/firm	Max. DM 800,000/firm
Special requirements	- Investment to be paid paid back pro rata - Reimbursement of remainder	- Investment to be paid back pro rata - No reimbursement of remainder	
Report required, publishing of R&D results required	yes yes		yes no
Rights of use and dissemination	yes		no
Administrating agency	BMFT or agency of BMFT	KfK Production engineering agency of BMFT	

Table (cont.)

Instrument of assistance/features	Contract research	Paragraph 4, Investment Allowance Act	Special depreciation of R&D investments (5/19/83 - 12/31/89)
Authorized applicant	Company engaged in trade or industry with sales up to DM 500 million/yr	Enterprises subject to taxes	income and corporate taxes
Requirements for funding	Outside contracts for obtaining new, improved technical products or procedures	(period of commitment 3 years)	R&D investments
Technical appraisal by panel of experts	no		no
Evaluation basis	-		-
	Outside R&D services	Procurement costs for intangible goods used in R&D	-
	-	-	-
	-	-	-
	-	-	-
	-	-	-
	-	-	-
	-	-	-
	-	-	-
	-	-	-
Amount of assistance	- 30% - 40% if sales are up to DM 50 million/year	- 20% based on max. DM 500,000 procurement & production costs/yr - 7.5% based on DM 500,000 procurement & production costs/yr	Special depreciation in year of procurement or production and in next 4 fiscal years up to - 40% for personalty - 10 or 15% for real property (1/3 to 2/3.use)
Maximum limit	Max. DM 120,000/year		-
Special requirements	Like personnel cost subsidy	- independent of other funding measures - cumulative claim possible	
Report required, publishing of R&D results required	yes no		no no
Rights of use and dissemination	no		no
Administrating agency	AIF under auspices of BMFT		Appropriate tax office

12552
CSO: 3698/366

SCIENTIFIC AND INDUSTRIAL POLICY

GOVERNMENT TO ENCOURAGE FOREIGNERS TO CONDUCT R & D IN ITALY

Milan INFORMATICA 70 in Italian Mar 85 p 18

[Text] The Government should not put juridical obstacles in the way of acquisitions of Italian firms by foreign capital--as has again been proposed recently--but should rather ask foreign firms intending to invest in Italy to maintain here or establish here not only a commercial and productive activity, but also a research and development activity designed to increase the country's know-how, especially in the advanced-technology sectors. This in substance is what Senator Luigi Granelli, minister of scientific and technical research, stated in his remarks at the Honeywell Information Systems Italia [ISI] Marketing Seminar in Rome. "Indeed," Granelli pointed out, "it is what is already occurring in firms like Honeywell ISI, which represents a major example of the possibility of a 'sound relationship' between multinationals and our domestic economy."

On the other hand, if the multinational firm fulfills this "reasonable condition," the minister said, there is no visible reason why the state should not intervene in support of the research being carried out by that firm in Italy, as it is doing (within the limitations of available means, of course) for our domestic firms, and particularly when the research concerns strategic sectors, or when the "high risk" involved prevents its inclusion in the firm's normal business plans.

Minister Granelli--who was received by the honorary president of Honeywell ISI, Ambassador Egidio Ortona; its president, Carlo Peretti; its managing director, Bruno Pavesi; and its general manager of marketing, Michele Cimino--addressed an audience of some 150 heads of the firm and members of its management staff. He expressed his pleasure at having been involved in this important event of business life, in that it is most appropriate that the minister of research have as interlocutors not only the scientific community but also the business firms.

"'Pure' research is unquestionably very important," said Granelli, "but it is no less true that the instrument that most directly contributes to a country's ability to compete on an international level is research applied to its productive activities."

Minister Granelli referred to the problem of research in Italy, where only 1.3 percent of the GNP [gross national product] (indeed, until a few years ago, this figure was less than 1 percent) is being allocated to this fundamental investment, versus the 2-2.5 percent of the other more highly industrialized European countries. The national budget provides for a total expenditure of 8,000 billion lire on research, but this total is distributed over no less than 150 budgetary line items pertaining to various ministries, and one might well question how much of this money actually gets used "productively," meaning for really innovative end-uses, and how much of it is squandered in widely scattered subsidies, often in support of obsolete and bureaucratized activities.

On the other hand, Law 46, which is the specific instrument for boosting the research and innovational effort among business firms, was not refinanced for 1984 and can only look forward to appropriations totaling not more than 1,800 billion lire for the period 1985-87--a truly meager sum when measured against the needs of an economy such as the Italian one, which, lacking adequate support of its research activities, risks falling permanently by the wayside with respect not only to the American and Japanese economies but also to those of the other European countries.

Turning to the European situation, and in response to a question voiced by Ambassador Ortona, Granelli pointed out that, in this respect, the EEC is no less lagging than Italy, in view of the fact that it devotes over 70 percent of its resources to farming problems, neglecting those of the industrial research sector. The minister emphasized, however, that it was nevertheless Italy--whose turn it is next to preside over the EEC--who requested that the bulk of the contributions the member countries are asked to make to the EC be put into the development of new industrial policies, and that it was Italy's intervention that finally carried the day for the startup of the Esprit project, the EEC's sole large-scale initiative in support of the data processing industry in Europe. And again it was Italy who, together with some countries but overcoming the opposition of others, put over the adoption of the criterion, for Esprit, that not only European firms would be eligible for funding, but rather any firm, provided it had a research activity situated in Europe. For--Granelli concluded--"inaccessibility" and protectionism are inadmissible even at the European level, and it is only through cooperation on a world scale that individual economies will be able to develop in the advanced sectors.

9399
CSO: 3698/428

SCIENTIFIC AND INDUSTRIAL POLICY

FIAT'S AGNELLI EXPLAINS EUROPEAN VENTURE CAPITAL INITIATIVE

Rome IL TEMPO in Italian 23 Mar 85 p 24

[Text] Fiat's Vice President Umberto Agnelli, took part in a seminar devoted to the study of venture capital initiatives in Europe, as a guest in Rome of the European Venture Capital Association.

After asserting in some detail the positive role venture capital initiatives can play in the European integration process, and emphasizing that "The enterprising spirit is not directly related to the size of a firm; the fact is that it is found in firms and organizations of all sizes," Agnelli dwelt at some length on an illustrative example of venture capital already in operation on a European scale: That of Euroventures B.N.

"This is a firm," Agnelli explained, "that was created with the participation of the principal member firms of the "European Enterprisers Roundtable." (Participating in this firm are: ASEA [expansion unknown], BSN [expansion unknown], Eternit, Fiat, Lafarge Coffee, Olivetti, Petrofina, Philips, Pirelli, Robert Bosch, Saint Gobain and Volvo).

"Roundtable," said Agnelli, "is a group that brings together the leaders of 22 big European firms, with the object of speeding up the integration of Europe and enhancing European industry's competitiveness. 'Euroventures' represents the first concrete initiative born of Roundtable."

Agnelli, who is also vice president of Roundtable, next explained the structure and operating mechanisms of Euroventures.

"Our Venture Capital initiative," he said, "consists of a 'mother' investment company and a number of 'satellite funds.' The "mother" company (called Euroventures B.N.) is a holding company formed in Holland, and participation in it is reserved solely to the member firms of Roundtable. The holding company, which is composed of 12 firms, has, as of today, a capital of 52 million ECU [European Counting Units), almost fully subscribed to by the participants."

The group's leading company will actively promote the Venture Capital initiative in Europe, operating either directly or through minority-ownership

investments via the "satellite funds" operating in different countries, and will coordinate the operation of the network of such funds that will gradually come into being. Three of these "satellite funds" are already being formed in the Benelux countries, Scandinavia and Italy. "The latter fund," Agnelli emphasized, "is the closest to the goal line." Concluding his remarks, the vice president of Fiat said: "The first steps being taken under this initiative are unquestionably encouraging, and I think the forming of the Italian satellite fund will contribute substantially to the development of the Venture Capital effort in our country."

9399

CSO: 3698/428

SCIENTIFIC AND INDUSTRIAL POLICY

HIGH-TECH APPLICATION, SUPPORT POLICY SUCCEEDS IN FRG STATE

Hamburg DIE ZEIT in German 5 Apr 85 pp 25,26

[Article by Uwe Vorkoetter: "Chip Chip Hurra: Technology Policy and Capitalism According to Spaeth"]

[Text] In Baden-Wuerttemberg, Lothar Spaeth is carrying out an innovative and aggressive economic policy which is worrying many a Northerner and at times irritating many a market economist. There is no lack of self-confidence: "We are going to market Aska in the face of strong world-wide American competition, and we are going to be successful," prophesied Peter Beyer, director of Ikoss GmbH in Stuttgart. "Aska" is a highly complicated computer program which is used to calculate the stability and resistance to vibration of technical designs high technology, made in Swabia.

The system, originally for the aerospace industry, was developed over the course of more than 10 years under the scientific direction of John Argyris, professor for mathematics at the University of Stuttgart. But after Aska proved to be as useful for the construction of the European Ariane rocket as well as for the Airbus and the Tornado, engineers in other fields are now also working with the program package: in the automobile industry, for example, in machine construction, and in the manufacturing of oil rigs.

Economic success is now supposed to follow on the heels of this technical success. Ikoss director Beyer intends to increase his sales from 40 to 100 million DM, and new jobs are waiting for hundreds of technicians, computer specialists, and merchants. "Marketing and distribution of the system would go far beyond the capabilities and responsibilities of the university," Chancellor Juergen Blum admitted frankly. Therefore the university has delegated these tasks to the Ikoss software company; the Swedish aviation company, Saab-Scania Aircraft, is also cooperating as an additional partner.

The Aska example is right in keeping with Lothar Spaeth's approach. In order to celebrate this "milestone in technology transfer" in an appropriate fashion, the minister-president arranged for the project to be announced to the public in his own state ministry. Aska symbolizes the microelectronic future, and Spaeth wants to make this attractive to the citizens and business people of this model little state - with great persuasive power and with a lot of money.

Whoever deals with chips, sensors, and glass fibers between Mannheim and Constance can count on the benevolence of the 'state's father.' "Baden-Wuerttemberg must become the focal point of technological research," Spaeth's minister for economics so proclaims the watchword of his master. And Johann Loehn, the state government's advisor for technology, promised "full speed ahead" in the integration of technological progress into the economy.

Existing conditions favor this development, since in recent years, the scientific infrastructure of Baden-Wuerttemberg has been steadily expanded. Stuttgart now has a new Institute for Microelectronics, Karlsruhe is home to a research center for computer science, and Heidelberg is becoming a center for biotechnology. In the new universities and the 24 technical colleges located in the state, in the large research facilities such as the Karlsruhe Center for Nuclear Research, and in 13 Fraunhofer societies and 14 Max Planck institutes, some 10,000 scientists are engaged in technological research.

These are balanced by a similar number of small-scale industrial firms, machine manufacturers and textile producers, electronic and precision engineering companies. Technological supply and demand are readily available. What is missing, in Spaeth's view, is above all the transfer of scientific knowledge to practical applications.

Even the Aska project, which was lauded as a model program, has its weak points in this regard. Although the American competition, a program called "Nastran" which was developed by the American space agency NASA, has, in the opinion of the mathematician Argyris, less to offer than does Aska and in addition was not ready for the market until 2 years after Aska, the Americans have by now a 5 years' lead on the world market. Argyris regretfully admits that they were quite simply better and faster in the application of the results of their research.

This is not the first time that the minister-president of Baden-Wuerttemberg has seen this happen. He believes that many areas in the electronics industry are lagging so far behind that it will be impossible for them to close the gap. Spaeth: "The important thing now is to keep the other sectors from making the same mistakes that were made in computer technology, i.e. to keep the period of time that elapses between research and marketable products as short as possible." In order to facilitate this, he has employed for a good 2 years now an advisor, Johann Loehn, professor, engineer, manager and multi-functionary, as a full-time "government advisor for technology transfer."

Loehn, who formerly lectured at the provincial technical college in Furtwangen, is always present when plans are being made for the transition from an industrial to an information society in the Southwest of Germany. It is taken for granted that Loehn always is one of the participants - whether at a meeting of the group of experts called "Foederungen, Kommunikation" [Grants, Communication], when state funds are distributed to young technological entrepreneurs, or when the future of the Swabian economy is on the agenda of the Cabinet. Lothar Spaeth's secret minister for technology directs investment, prepares the way for cooperation between companies, organizes technological factories, and, in his own description, carries out a "hard-

hitting" consulting service to business.

In the past 2 years, factory owners in Baden-Wuerttemberg have come to him for technological advice about 3,000 times, and in most cases he was able to help. He helped, for example, a machine tools manufacturer who had run into problems with a contract with the Soviet Union, because he had underestimated the difficulties arising from the electronic controls system of a milling machine. The technological advisor brought in experts who developed a software solution in cooperation with the company. Result: "The company was able to keep to the time frame that had been agreed upon." A small company that dries quartz sand by burning natural gas was also able to be helped. This energy-intensive, production process was measured, evaluated, and optimized. The annual cost saving is estimated at 67,000 DM, with additional investment expenditures of 137,000 DM.

Such success stories are possible because of the consistent involvement of scientific personnel in the state with economic planning. Government advisor Loehn works with 600 researchers at the universities and at institutes who provide professional guidance in the form of expert evaluations and commentary. At the heart of his advisory system are twelve - soon to be thirteen - 'transfer centers' that are scattered throughout the state, which look after the special needs of the regional economy. In Aalen, for example, there is an advisory office for automation technology, and in Heilbronn a transfer center for 'applied electronics.'

Within a few years, an additional technology network is to be in place throughout the southwestern state: start-up centers for young business people and scientists from high tech areas who wish to take the plunge into entrepreneurship. Work is already underway in two of these technology factories, in Karlsruhe and in Sankt Georgen in the Black Forest, another three are under construction, and the state government is holding talks with 16 other cities.

Lothar Spaeth's chip-chip-hurra strategy does not evoke pure admiration inside and outside of Baden-Wuerttemberg. In his own economics ministry, for example, Spaeth offended others by naming a technology adviser. High officials speak sourly of the "separation of governmental functions from governmental administration." And it is actually true that Spaeth very consciously placed his Loehn outside of his own administration. He is convinced that it is impossible to carry out an aggressive technology policy with a cameral financial system.

More serious misgivings concerning Spaeth's bold undertaking have to do with regulatory policies. Evidently, the clever little Swabian, as he is called by his North German CDU friends, feels that the future of the economy is too important to be left to the economy alone. He claims, "It is just too easy to cling to the slogan: 'Everything is controlled by the market.'" The futurist politician from Baden-Wuerttemberg has arranged a whole series of commitments to actions on the part of the state: the public sector and the private sector are together supposed to analyze world-wide development processes in Spaeth Capitalism, design world market scenarios, and from these develop national economic and political strategies - Japan is not far away from the Neckar.

In other federal states, the ideas of the Christian Democrat are regarded with a mixture of amazement and alarm. Especially in the North of the FRG some fear that only Bavaria at best will be in a position to meet the challenge that Spaeth has put to the other federal states. Whoever feels it necessary to help coal, steel or the shipyards to survive will not be able to invest hundreds of millions in the new technologies. But Spaeth can do just this. At times he steps up the relevant federal subsidy programs, with new state initiatives supplementing the catalogue of available grants. These range from basic help with the founding of a new company to 'Support for the Implementation of Modern Technologies in mid-scale Industry,' to 'Support for the Equipping of the Manufacture of New Products.'

How much money the Swabians have invested as a whole in the encouragement of technology remains their secret. The money is flowing from so many different sources that its sum is about as hard to calculate as that of the total amount of Soviet arms expenditures. The sum of 280 million DM annually has not been confirmed, but neither has it been denied.

In any case, the minister-president is convinced that the money has been wisely invested, and he can point to the opinion of prominent experts. The Organization for Economic Cooperation and Development (OECD) in Paris recently confirmed that his support for technology was 'the most highly developed' in the international arena. In the face of such praise, Lothar Spaeth has dismissed any last reservations concerning his subsidies for technology. Where his minister for economics still is speaking with some embarrassment of a "market economy tightrope-walk," the government head clearly affirms the support of the economy, as long as this takes place in keeping with the Baden-Wuerttemberg model. "In our industrial policy and in the area of subsidies we finally have to quit fighting yesterday's battles." Instead, the Southwest is arming for the struggle for shares of the world market of tomorrow.

12792

CSO: 3698/411

SCIENTIFIC AND INDUSTRIAL POLICY

LEGAL STATUS OF FRG RESEARCH INSTITUTES FOR TAX PURPOSES

Frankfurt/Main FRANKFURTER ZEITUNG/BLICK DURCH DIE WIRTSCHAFT in German
11 Apr 85 p 4

[Article by bs: "Imposition of Sales Tax Upon Research Societies and Associations"]

[Text] In a judgment handed down on 20 December 1984 (V R 25/76) the sales tax division of the German Federal Finance Courts essentially sustained the so-called sphere theory developed in a decree of the German federal minister of finance on 15 March 1971 (FEDERAL TAX GAZETTE, Part I, 1971, p 189). In accordance with this theory it is possible with regard to taxation for an enterprise to have simultaneously an entrepreneurial aspect and a nonentrepreneurial aspect. According to the judgment, this applies to all enterprises regardless of their legal or organizational form. In the case of an individual as an entrepreneur, besides the enterprise itself one presupposes the private existence of the entrepreneur with its own private sphere. The court held that a similar distinction applies to societies. In the view of the judges and also of the financial administration this sphere theory implies that the entrepreneur cannot justify a preliminary tax deduction in connection with income for services which he has assigned entirely to his nonentrepreneurial area. This question of the boundaries of entrepreneurial activity and proper preliminary tax deduction also arises in the case of associations, research facilities and similar institutions.

The litigation concerned sales tax imposed on a registered association which according to the terms of its constitution operates to promote aeronautics and astronautics and represents both internally and externally the interests of its members-- individuals and also company-linked enterprises. Preliminary tax deduction was under dispute in connection with specific activities of the association, regarding which there was a question as to whether these activities involved the promotion of the general interests of the association or whether the association was acting in the special interests of specific members. This concerned the production of conference reports, specialized studies, participation in specialist congresses and specialized expositions. If such activities are in the interest of the association and if the members are obliged to make additional membership contributions in the form of expense levies or if the members have voluntarily paid these without comment then according to the judgment in such a case one is not dealing with a taxable

service provided by the association to its members. Then also to that extent there will, of course, be no preliminary tax deduction.

In opposition to the view of the finance administration the senate decided that also those so-called auxiliary businesses which involve the "operation" of the nonentrepreneurial domain are to be treated as businesses of a nonentrepreneur and hence are nontaxable. The sale of used automobiles or used equipment would be an example of such auxiliary business. It would likewise be permissible for the nonentrepreneurial domain to make purchases as well as sales. From the point of view of profits taxation activities in this latter domain were judged to be irrelevant.

8008

CSO: 3698/409

END