

1998

The Integrated Navigation Capability for the Force XXI Land Warrior

Author

Richard B. Marth, Sr.
U.S. Army Topographic Engineering Center
7701 Telegraph Road
Alexandria, VA 22315-3864

Contributing Authors

Robert Levi
Dr. C. Thomas Judd
Point Research Corp
Santa Ana, CA

Dr. I. Newton Durboraw, III
Motorola
Scottsdale, AZ

Kenneth Beam
U.S. Army Communications and Electronics Command
Fort Monmouth, NJ

Abstract: For decades the dismounted soldier has navigated to his mission objective using maps, a compass, and his pace count as navigation tools. Recently, Global Positioning System (GPS) receivers were added as an additional aid to dismounted navigation. However, GPS is limited as a navigation aid by its inability to provide static heading and its lack of availability when used around obstructions (terrain or man-made), or in the presence of jamming. Therefore, maps, a compass, and a pace count are still needed to ensure successful navigation. Under the Force XXI Land Warrior (FXXI LW) program, a Government-Industry team is prototyping an integrated navigation system for the dismounted soldier. The integrated navigation system consists of GPS and a Dead Reckoning Module (DRM). The DRM makes use of state-of-the-art, small, low power electronic components in a single miniaturized package to replace the compass and the need for the soldier to count paces. The DRM design allows hands-free navigation. The DRM data and GPS information are used by a Kalman filter to form an integrated navigation solution by balancing the weaknesses of one sensor using the strengths of the other sensor. The integrated navigation design provides automatic selection of one navigation

data source when the data from the other position sensor is corrupted or not available. The design also provides for manual selection/deselection of a navigation source. Upon successful completion of testing, the integrated navigation technology will be transitioned to the Land Warrior (LW) system. This paper will discuss the DRM and the Integrated Navigation development, assessments performed to date, and future plans.

Introduction

The ability to navigate has been a military requirement since one tribe/nation decided to control the greener pastures or hunting grounds on the other side of the hill. Navigation tools and methods have been devised to meet this requirement. As technology has advanced so, have the navigation tools. Today most major weapon systems and target acquisition systems use navigation tools that include inertial navigation systems (INS), Global Positioning System (GPS) receivers, or an integration of INS and GPS as their navigation tools. These systems are too heavy, require too much power, and are too expensive for the dismounted soldier to use as navigation tools.

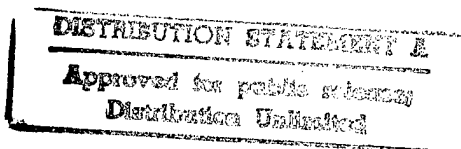

Force XXI Land Warrior Program

For the dismounted soldier, the navigation tools are the Precision Lightweight GPS Receiver (PLGR) and the same tools that have been used for more than 100 years: map, compass, and pace count. When the dismounted soldier plans a mission, the map is consulted to plan the route to the objective and the return route. A route that offers the best cover and concealment is chosen. Along the route, waypoints, waypoint coordinates, and the direction between waypoints are noted as well as the distance between waypoints. The distance and direction information allows the soldier to do dead reckoning navigation between waypoints. If a PLGR is available, the waypoints can be entered and when an accurate GPS position is available, PLGR provides the soldier bearing and distance to the next waypoint in the route.

Background

The U.S. Army Topographic Engineering Center (TEC) began to address the need for an advanced navigation capability for the dismounted soldier in the late 1980's. In 1991, the development of a digital compass had been completed by Precision Navigation, Inc., under a Small Business Innovative Research (SBIR) contract. The compass required little power, had +/- 45 degrees tilt compensation range, and had no moving parts. With the completion of the development of the digital compass, TEC proposed a Science and Technology Objective (STO), titled "Personal Navigation and Reporting System (PNRS)" in 1991. The STO would investigate the development of a distance measuring capability and its integration with the digital compass to form a dead reckoning navigation module (DRM). A PNRS concept model built with commercial parts (Figure 1), called PointMan™, was completed in 1995 by Point Research Corp., (PRC), under an award winning SBIR contract. The DRM was successfully demonstrated to the Dismounted Battlespace Battle Lab (DBBL), FXXI LW, and Motorola, Corp., (the FXXI LW contractor). Motorola recommended that the PRC DRM be selected as the system that would provide the integrated navigation capability for FXXI LW. FXXI LW and TEC funded a modification to the SBIR contract for the design and breadboard of a smaller DRM whose size and weight would meet the needs of LW. By developing a new digital compass with tilt-compensation, PRC was able to make the DRM smaller. In 1996, PRC and Motorola signed a contract for further development of the DRM for the FXXI LW with the goal of inserting the DRM into LW.

The FXXI LW Program has identified evolutionary technologies that have the potential for early insertion into the Land Warrior System, Integrated Navigation being one. FXXI LW is fostering the maturity of each capability to meet the size, weight and power requirements for a minimum impact when incorporated into LW. Each of the potential insertions is refined by going through assessments at the DBBL for feedback on performance and user acceptance. The Proof-of-Concept (POC) demonstrations are scheduled for March 1998, at which time a decision for insertion into prototype LW systems will be made. The POC's will be performed

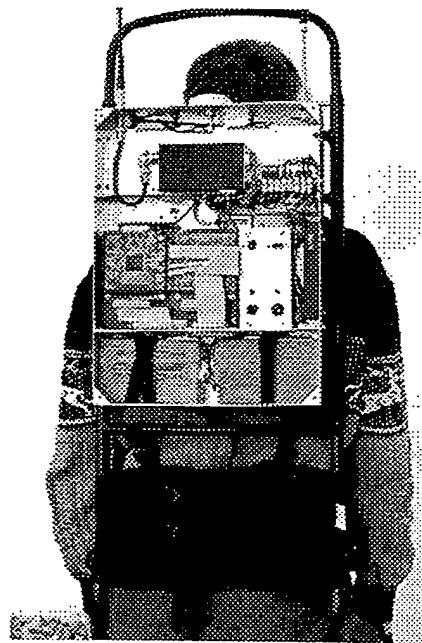

Figure 1

using surrogate LW hardware since LW systems are not available. Upon successful completion of POC, work on the final form for use in LW will be completed and integrated into Early User Test models of LW. As mentioned above, Integrated Navigation is one of these capabilities. The Integrated Navigation hardware, surrogate LW hardware, and the assessments performed to date are discussed below.

DRM Hardware

The DRM consists of two circuit boards that are sandwiched together to form a neat 1.9 X 2.9 X 0.6 inch, 1.4-ounce package (Figure 2). The DRM operates on 2 to 5 volts and has a power consumption of about 0.5 watts.

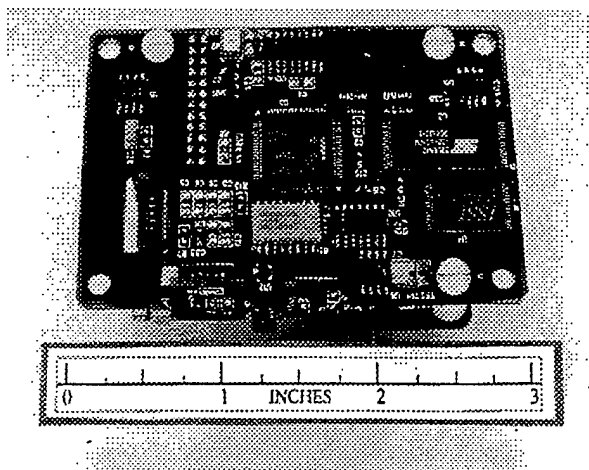

Figure 2

One of the two circuit boards is analog, and the other is digital. The analog board contains the tri-axial magnetometers, the tri-axial accelerometers, a temperature sensor and a barometric altimeter. The magnetometers measure the earth's magnetic field and provide a 3-D vector of the field relative to the DRM. The accelerometers perform two functions. One is to determine a horizontal plane, thus allows the DRM to look only at the horizontal component of the magnetic field. This is important since the vertical component of the magnetic field can be large, and if the vertical component were used for heading determination, a small 1 degree tilt error could result in almost 2 degrees of heading error.

The accelerometers are used to determine when a step is taken. Each time a step is taken the body has some vertical motion. This vertical motion is measured by the accelerometers, and by filtering the vertical acceleration, the steps taken by the person are counted. The step signal threshold is set to eliminate false detections from normal body movements while standing still.

The DRM has RS-232 serial interface ports for communication. The computer - DRM link allows the computer to control the DRM via defined message packets. As soon as the DRM is powered up, it starts sending position information. If the host computer does not provide a position, the position reported is the initial position plus update from when the DRM is turned on. If initial position coordinates are available from either GPS or from operator entry, the position reports are an estimate of the current coordinates of the soldier. When precise GPS positioning is available, it is used by the DRM to determine step size and the orientation of the

module on the individual, and is stored as calibration constants.

Surrogate LW Hardware

The LW system includes a computer with an embedded GPS card, a heads-up display, and an auxiliary display. The computer and embedded GPS card will be incorporated into the load-bearing backpack frame. The GPS antenna will be on the soldier's shoulder and heads-up display will be part of the LW headgear. The auxiliary display will be worn on the belt and tethered to the frame. For assessments and POC, a small, ruggedized 486 pen computer serves as the LW computer. The computer runs the Integrated Navigation software under Microsoft Pen Windows. The computer also serves as a data logger. The surrogate for the LW GPS receiver is the Precision Lightweight GPS Receiver (PLGR). Figure 3 shows the equipment configuration.

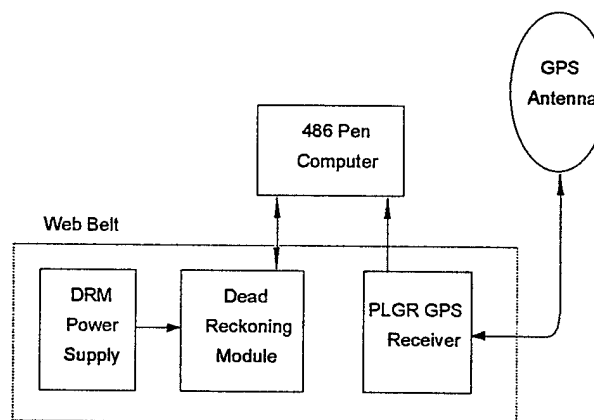

Figure 3

FXXI LW Modes of Operation

Integrated Navigation has four primary modes of operation: Integrated Mode, Self-Contained Mode, GPS Mode, and Power Down Stop Mode. The DRM supports the Integrated Mode and the Self-Contained Mode. Integrated Navigation is providing mode management that is transparent to the soldier. The LW System will automatically be placed in best navigation mode based on power consumption, status of navigation sensors, required position, and navigation accuracy and mission conditions.

The Integrated Mode: The Integrated Mode makes use of the benefits of both GPS and Dead Reckoning navigation through the use of a Kalman filter. The GPS provides an accurate estimate of position as the soldier walks. While the soldier is walking, the DRM is estimating position based on steps taken, an initial step size value, compass direction, and an initial body offset. The Kalman filter adjusts the step size and the body offset using the GPS information. Spurious jumps in GPS position can also be adjusted by the Kalman filter. Figure 4 shows an example of the Kalman filter at work adjusting the step size and body offset. In this mode, Integrated Navigation is required to give position data at least as accurate as GPS.

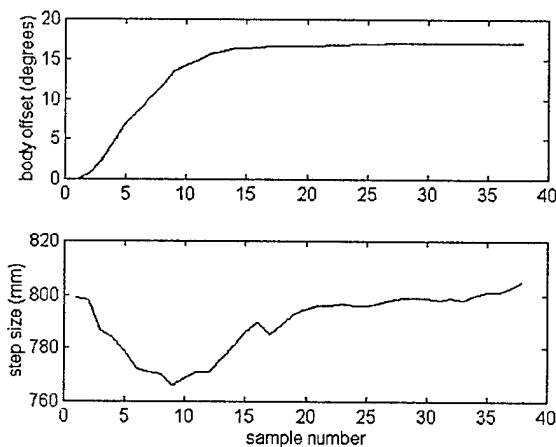

Figure 4

Self-Contained Mode: The Self-Contained Mode is used when GPS is degraded or when GPS signals are denied by either terrain (natural or man-made) features or by jamming. The soldier's position is determined by using step count from a starting point, step size and compass direction adjusted for body offset. The starting point position can be the last good GPS position, a manually entered map coordinate or survey point. The step size and body offset also can be manually entered by the soldier. In this mode, the required horizontal accuracy is 2 percent of distance traveled under benign conditions (level road surface where the calibrated stride can be maintained) and within 5 percent of distance traveled through rough terrain (more difficult to maintain consistent stride).

Assessments

Two user assessments have been conducted using the Integrated Navigation capability, the first in June 1997 and the second in December 1997. Both assessments were held at Fort Benning, GA with the support of DBBL

personnel. The varying terrain of DBBL's Griswold Range was used to evaluate Integrated Navigation for both assessments. Performance in urban terrain was evaluated at the McKenna Range's Military Operations Urban Terrain (MOUT) village. DBBL support included the use of their Griswold Range facility, military and ex-military personnel with land navigation experience, maps, and survey control points for performance measurements.

First Assessment

The first Integrated Navigation assessment was conducted 22 - 27 June 1997 at Fort Benning, GA. The objectives of the first assessment were the following:

- a. solicit user comments on the information displays
- b. solicit user comments on the operation and functionality of the Integrated Navigation
- c. collect data to check performance of the DRM and the Kalman filter
- d. solicit information on the current navigation techniques used by dismounted soldiers, and
- e. collect information about operation of the Integrated Navigation in the urban environment of the McKenna MOUT site.

Five DBBL employees and one active duty infantryman were the evaluators for the assessment. The DBBL employees were retired infantrymen with dismounted navigation experience. The evaluators were trained on the operation of the surrogate Integrated Navigation system. Since there were only three surrogate systems, two training sessions were held in the morning of the first 2 days of the assessment. In the afternoon of these 2 days, the trained users walked routes to gain more familiarity with the system.

Figures 5, 6, and 7 are examples of the tracks walked during the assessment. For the walk shown in Figure 5, the Integrated Mode was used. GPS and DRM outputs are plotted separately, and as the plot shows, the GPS and DRM position estimates agree quite well as expected. Figures 6 and 7 show walks taken at the same time by two evaluators. From point 6 to point 5 (450 meters), both units are in the Integrated Mode, and from point 5 to point 1 (960 meters) they are in Self-Contained Mode. The total distance as measured by the two DRMs differed by only 2 meters. The azimuth of one unit was off by 8 degrees. The exact cause of the azimuth error could not be determined. It could have been because one unit was found to have an intermittent magnetometer, or, it could have been the result of the DRM being shifted while the PLGR was turned off at point 5.

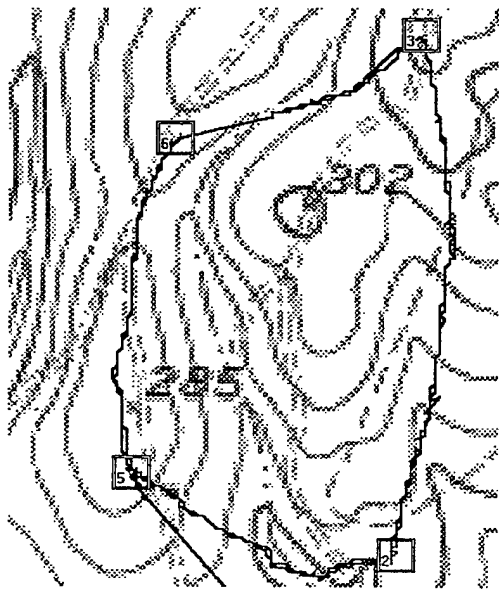

Figure 5

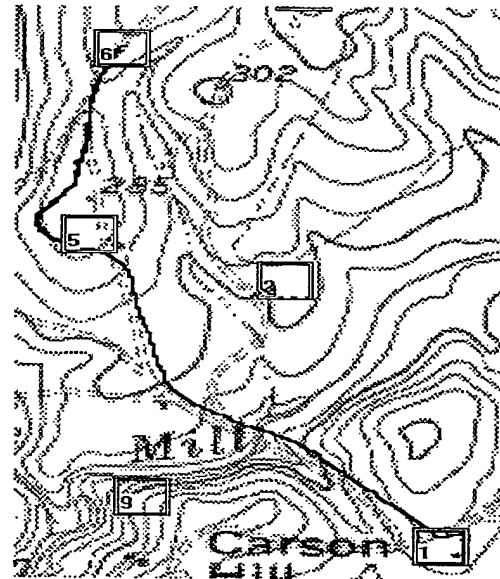

Figure 7

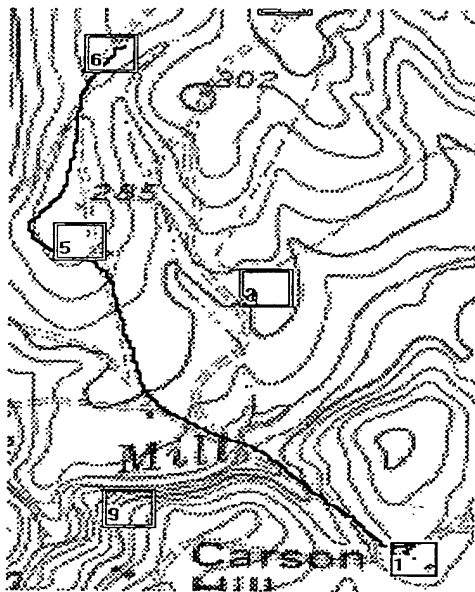

Figure 6

The McKenna MOU site was visited on the last day of the assessment. The evaluator walked along the streets of the MOU village and inside buildings (restricted to the ground floor). The MOU village also has tunnels which the evaluators entered. During the walk the structure of the buildings was observed and it was noted that the buildings are made of block and concrete with little metal. The tunnels are made of reinforced concrete. The compass was watched during the walk and it was noted

that the buildings did not introduce a direction error. However, the compass was affected during the walk in the tunnel because the evaluator had to bend at the waist to traverse the tunnel.

First Assessment Comments: The evaluators liked the system and made the following comments on its benefits:

- a. the automatic pace count allowed them to focus on the mission and the surrounding events
- b. the indicator of direction and distance to the next waypoint allowed them to go around obstacles without having to mentally adjust the pace count to the waypoint
- c. the map and information displays were liked, but needed some minor changes.

The evaluators and members of the Integrated Navigation team noted some changes to the Integrated Navigation design and operation that would be beneficial. These changes are shown below.

- a. any coordinates that are displayed should be shown in the Military Grid Reference System
- b. the software should be changed to allow the compass direction to be shown when the person is not walking
- c. when the Self-Contained Mode is in use, allow the person to adjust the pace size based on the terrain conditions just as they do now when navigating across country.

This assessment also pointed out the need for better data collection methods. To simulate the loss of GPS, the

PLGR had to be turned off. This action might have caused the belt, thus the DRM, to move from its calibrated position. This also meant that GPS could not be collected while in Self-Contained Mode, and be used as a benchmark.

Second Assessment

The second Integrated Navigation assessment was held 8 - 11 December 1997, again at Fort Benning, GA. The same six evaluators who performed the first assessment were used to conduct this assessment. The goals of this assessment were to:

- a. check the design changes made since the first assessment
- b. collect performance data for the modes of Integrated Navigation system
- c. collect performance data for different types of terrain
- d. solicit comments from the user on displays and operation.

As was done for the first evaluation, the six evaluators were divided into two sets of three. Training consisted of a review of the surrogate systems operation, training on the changes that were made after the first assessment, and a review of the routes to be walked and what modes were to be used on the legs of the routes.

Uniform Terrain Test: The uniform terrain tests were conducted on an asphalt road. Figure 8 shows the data collected for one of the evaluators. Integrated Mode was used between point 8 and point 9, and Self-Contained Mode was used between point 9 to point 10. The return walk was 10 - 9 - 8 with Self-Contained Mode used between point 9 and point 8. The Integrated Mode leg was used to obtain optimal calibration values for stride length and body offset. Table 1 shows the error for the Self-Contained legs based on survey position for 8, 9, and 10.

Woodland Terrain with Intermittent GPS Test: Figure 9 is a picture of the woodland terrain at Griswald Range. Figure 10 shows the 3 km route walked for this test. The evaluator walked from 1 to 11 to 2 in Integrated Mode. Between points 2 and 3, the Self-Contained Mode was used. For the remainder of the walk (3 - 4 - 6 - 7 - 11) GPS was cycled, on for 30 seconds, then off for 5 minutes. Figure 11 shows the position data collected relative to point 1. The circles indicated operation in the Integrated Mode; the lines show GPS and DRM positions. Table 2 shows the results of the test. The column

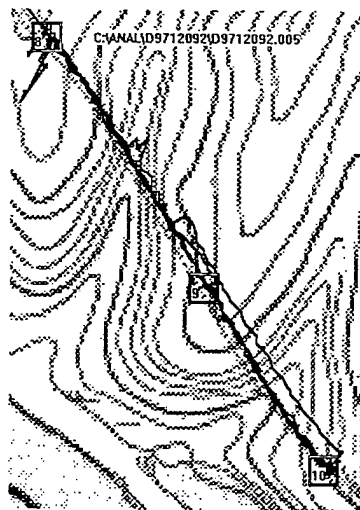

Figure 8

Table 1. Uniform Terrain Trial Results Based On Survey

Date	DRM Ser. No.	Percent Distance Traveled Error				Trial Avg.
		A	B	C	D	
Dec. 9	19	1.33	1.75	2.67	4.0	2.44
Dec. 9	21	4.3	0.5	1.33	2.0	2.00
Dec. 10	18	2.3	3.25	0.33	2.25	2.03
Dec. 10	19	2.67	1.75	5.0	4.5	3.48
Dec. 10	21	0.3	3.0	2.3	N/A	1.86
Overall Average						2.36



Figure 9

labeled "During Self-Contained" shows the error for data recorded between points 2 and 3; the column "During

Cycling" shows the error for data recorded for the rest of the walk.

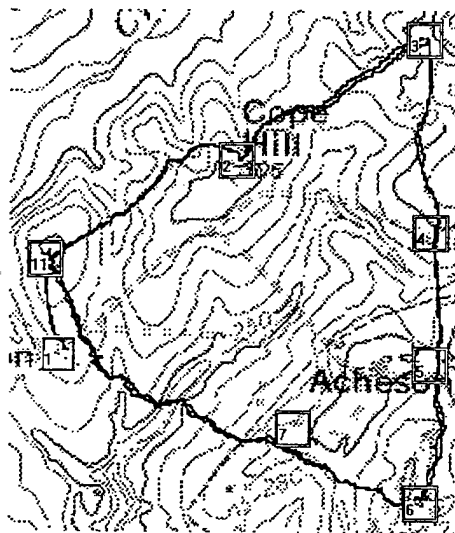

Figure 10

assessment was the need for the operator to have the ability to adjust the step size based on the terrain being traversed. This test was designed to check the benefit of having this capability in the Integrated Navigation System. Figures 12 and 13 show the walks of one of the evaluators. For both walks, the Integrated Mode was used on a dirt road between points 1 and 4. At point 4 the

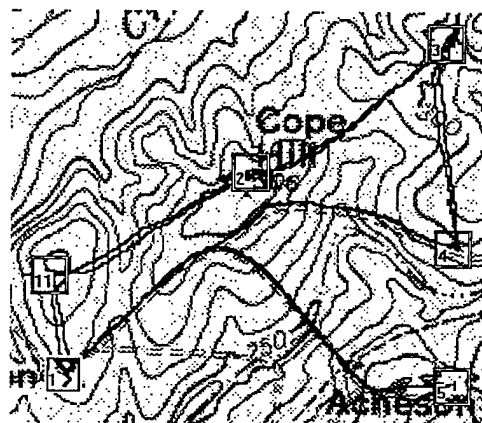

Figure 12

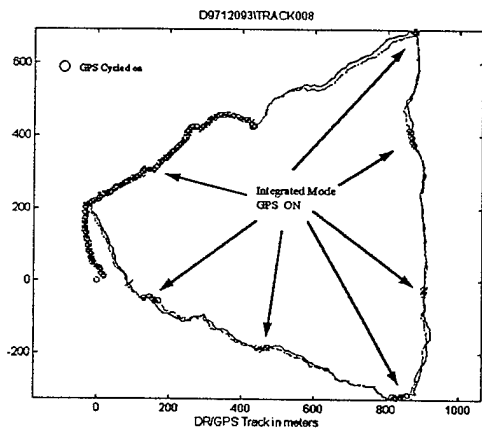

Figure 11

evaluators left the road and started across country over mixed terrain on the route 4 - 3 - 2 - 11 - 1. The Integrated Navigation System was in Self-Contained Mode for this portion of the walk with the stride length determined on the road, an intentional terrain calibration mismatch. The walk plotted in Figure 12 shows the route with no changes to the stride adjustment. The plot in Figure 13 shows the walk with the evaluator making stride adjustments between waypoints. Tables 4 and 5 contain the results of the two tests. Overall, the results show making the manual correction for stride may offer a slight improvement in performance. For several of the evaluators, there was a significant improvement. Since

Table 2: Woodland Terrain Error Summary

Date	DRM Ser. No	During Self-Contained	During Cycling
Dec. 9	19	3.9%	5.5%
Dec. 10	18	3.7%	3.7%
Dec. 10	19	1.7%	6.1%
Dec. 10	21	4.5%	4.5%
Overall Averages		3.4%	4.9%

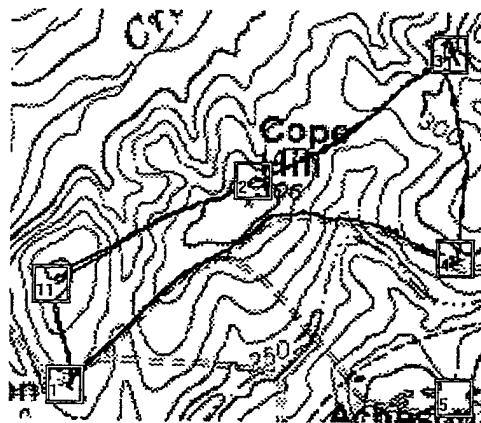

Figure 13

Mixed Terrain with and without Manual Stride Adjustment: One of the lessons learned in the first

the stride adjustment selected by the evaluator was subject to experience and judgment, more experience/training in different types of terrain may be beneficial.

Table 4. Mixed Terrain Route Errors During First, Uncorrected, Circuit

Date	DRM Ser.	4 → 3 422 m	3 → 2 516 m	2 → 11 505 m	Average
Dec. 9	21	5.1%	8.6%	11.8%	8.5%
Dec. 9	19	4.5%	2.9%	2.6%	3.3%
Dec. 9	18	12.0%	12.5%	11.4%	12.0%
Dec. 10	21	10.6%	7.9%	13.0%	10.5%
Dec. 10	19	3.3%	3.8%	6.0%	4.4%
Dec 10	18	5.2%	7.0%	7.1%	6.4%
Overall					7.5%

Table 5. Mixed Terrain Route Errors During Second Circuit With Corrections

DRM Ser. No.	4 → 3 422 m	3 → 2 516 m	2 → 11 505 m	Average
21	6.9%	9.8%	10.0%	8.9%
19	3.9%	5.4%	6.3%	5.2%
18	4.1%	1.5%	4.7%	3.4%
21	3.2%	7.0%	5.6%	5.3%
19	8.7%	2.4%	2.5%	4.5%
18	7.2%	2.9%	4.2%	4.8%
Overall				5.35%

MOUT Site: This portion of the assessment was a qualitative evaluation of the performance of the Integrated Navigation System in an urban environment. There was no survey data to compare positioning. Figure 14 shows the path of an evaluator walking in a simulation of a building clearing exercise. The evaluator stooped, crawled, and walked during the exercise. He entered building "I" and crawled through holes in interior walls. The figure shows that the DRM position (the black line) remained close to the the actual path walked. The GPS position had large variations (gray line). These large variations are thought to be cause by to multipath and the loss of GPS signal near the buildings and while in the building "I."

Conclusions

All the assessments and work done to date indicate that the Integrated Navigation System has benefits for the Land Warrior. Evaluators liked the system because they could concentrate on their surroundings rather than having to count strides. The system performed well and put the evaluators very close to the waypoint that they were looking for. This was another point that impressed them.

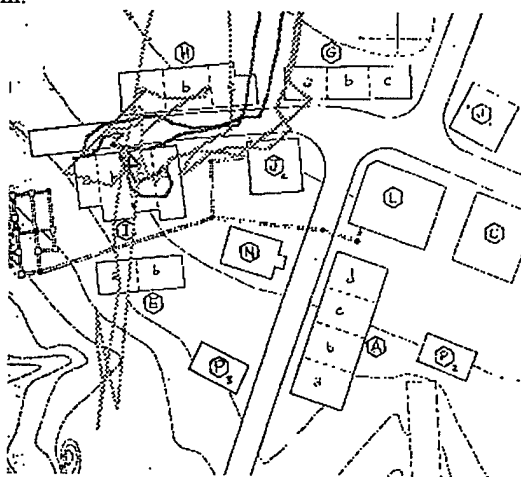

Figure 14

Preparations for the POC demonstration are underway and the POC will have been completed by the time this paper is presented. In POC, soldiers will use the Integrated Navigation System during a rendezvous mission and during a re-entry mission.

References:

1. Dr. T. Judd, "Integrated Navigation Assessment, Ft. Benning, 22-27 June 1997," Part Number 095-1007, Version 1.1, 14 July 1997, Point Research Corporation.
2. R. Marshall & Dr. T. Judd "Integrated Navigation Assessment, Ft. Benning, 8-11 December 1997," Part Number 095-1010, Version 1.1, 23 January 1998, Point Research Corporation.
3. Dr. T. Judd, "A Person Dead Reckoning Module," presented at Institute of Navigation's ION GPS '97, September 1997, Kansas City, MO.

Acknowledgments

The authors wish to thank the following Dismounted Battlespace Battle Lab personnel for their support and assistance: Chris Kerns, Tony Mason Mike Kennedy, CPT Paul Hurley, Ron Ackers, Andrew Fowles, Ruben Montiel, Don Purdy and Dave Cummings.