

365017

JPRS-ESA-85-030

7 October 1985

East Europe Report

SCIENCE AND TECHNOLOGY

DISTRIBUTION STATEMENT A
Approved for public release;
Distribution Unlimited

DTIC QUALITY INSPECTED

19981022 100

FBIS FOREIGN BROADCAST INFORMATION SERVICE

REPRODUCED BY
NATIONAL TECHNICAL
INFORMATION SERVICE
U.S. DEPARTMENT OF COMMERCE
SPRINGFIELD, VA. 22161

3
42
A03

NOTE

JPRS publications contain information primarily from foreign newspapers, periodicals and books, but also from news agency transmissions and broadcasts. Materials from foreign-language sources are translated; those from English-language sources are transcribed or reprinted, with the original phrasing and other characteristics retained.

Headlines, editorial reports, and material enclosed in brackets [] are supplied by JPRS. Processing indicators such as [Text] or [Excerpt] in the first line of each item, or following the last line of a brief, indicate how the original information was processed. Where no processing indicator is given, the information was summarized or extracted.

Unfamiliar names rendered phonetically or transliterated are enclosed in parentheses. Words or names preceded by a question mark and enclosed in parentheses were not clear in the original but have been supplied as appropriate in context. Other unattributed parenthetical notes within the body of an item originate with the source. Times within items are as given by source.

The contents of this publication in no way represent the policies, views or attitudes of the U.S. Government.

PROCUREMENT OF PUBLICATIONS

JPRS publications may be ordered from the National Technical Information Service, Springfield, Virginia 22161. In ordering, it is recommended that the JPRS number, title, date and author, if applicable, of publication be cited.

Current JPRS publications are announced in Government Reports Announcements issued semi-monthly by the National Technical Information Service, and are listed in the Monthly Catalog of U.S. Government Publications issued by the Superintendent of Documents, U.S. Government Printing Office, Washington, D.C. 20402.

Correspondence pertaining to matters other than procurement may be addressed to Joint Publications Research Service, 1000 North Glebe Road, Arlington, Virginia 22201.

7 October 1985

EAST EUROPE REPORT
SCIENCE AND TECHNOLOGY

CONTENTS

BULGARIA

Failure To Improve Air Traffic Control System Criticized
(Veselka Marinova; RABOTNICHESKO DELO, 28 Aug 85)..... 1

GERMAN DEMOCRATIC REPUBLIC

Image Processing Systems, Potential Reviewed
(A. Geschke, R. J. Vilser; NEUE TECHNIK IM BUERO, No 1
1985)..... 4

Graphics Module for Plotting Conductor Diagrams
(J. Reinaecker; NEUE TECHNIK IM BUERO, No 1, 1985)..... 7

Briefs
Titanium Microalloy Steel Tested 8

POLAND

'ZAMET' Line of Soaking Furnaces Profiled
(Andrzej Taranczewski; POLISH TECHNICAL REVIEW, No 1,
1985)..... 9

'ELTERMA' Line of Heat Treatment Furnaces
(Zdislaw Szarapanowski; POLISH TECHNICAL REVIEW, No 1,
1985)..... 17

Data on Laminar Air Flow Chamber
(POLISH TECHNICAL REVIEW, No 1, 1985)..... 21

Design Engineer on Development of Pulsed Heating Furnaces
(Kazimierz Suchon Interview; POLISH TECHNICAL REVIEW,
No 1, 1985)..... 22

New Products in Chemistry, Metalworking, Electronics, Other
Fields Reported
(POLISH TECHNICAL REVIEW, No 1, 1985)..... 27

Refractory Properties of Beta-Alumina Ceramics in Molten Sodium
(Grzegorz Rog; SZKLO I CERAMIKA, No 2, 1985)..... 35

BULGARIA

FAILURE TO IMPROVE AIR TRAFFIC CONTROL SYSTEM CRITICIZED

Sofia RABOTNICHESKO DELO in Bulgarian 28 Aug 85 pp 1, 3

[Article by Veselka Marinova: "A Staged Spectacle or Denial of Innovation?"]

[Text] On 3 July RABOTNICHESKO DELO published a page devoted to a meeting with participants in the national competition, Research and Implementation at World Standards. At this meeting, Rumen Nikov, of the Air Transport Institute of the Bulgarian Civil Aviation Economic Trust, spoke about the microprocessor system which has been developed for flight control. The collective's problem was that for 5 months it was not possible to find an organization which would finance the development work.

Instead of receiving help, up to the day of our check things were turned around 180 degrees. The technical-economic council at the Bulgarian Civil Aviation Economic Trust reacted very quickly to the critical comments in the newspaper. At its meeting on 9 July, the council adopted a resolution to . . . discard the innovative proposal.

After all, the technical-economic council is a legal organ, which can adopt or reject a proposal. Unfortunately, everything is in order only at first glance, because a closer look at the documents and at conversations with everyone who has any involvement in the development shows that there is a conflict between Rumen Nikov, the leader of the collective, on the one hand, and on the other, the leadership of the trust, headed by Viktor Nan'ov, the vice-general director for technology and material resources and the president of the technical-economic council.

What is this conflict about, against whom is it directed? In order to answer these questions, we have to go back a little. While working on his dissertation, Rumen Nikov came to conclusions, which were made together with specialists from the trust and the V. I. Lenin Higher Machine-Electrical Institute, to develop a microprocessor system for flight control. These conclusions could be briefly explained as follows: The presence of such a system would decrease the time a plane stands idle on the ground, as well as the waiting time for takeoffs and landings, which leads to a savings of fuel and flying time, thus using this system, the process of flight controllers' decision-making about air traffic control could be automated. According to the authors of the innovative proposal, these problems would be, if not totally overcome, then at least reduced to a minimum.

Logically, such a development would be given a high rating. And indeed, according to Protocol No 10 of 10 January 1985, the innovative proposal was adopted by the technical-economic council of the Air Traffic Leadership. Later a report was prepared for delivery to the Bulgarian Civil Aviation Economic Trust, about ensuring the means necessary for experimenting with the system.

However, what was the reaction? In response, the vice-general director for technology and material resources formulated a note which was examined on 9 July at a meeting of the technical-economic council at the trust. In it, he recommended that the technical-economic council accept the following: "Reject the innovative proposal. A flawed method of calculating the economic effect is used in it. The attention of the leadership of air traffic and its technical-economic councils drawn to the insufficient examination of the question of its competence. A recommendation is made to all presidents and members of technical-economic councils at all enterprises to refrain from participating in any way with the innovative proposals (including consultants at creative collectives for implementation), where the proposals would be voiced."

The technical-economic council at the Bulgarian Civil Aviation Economic Trust rejected the development and adopted all the recommendations of the report. A new approach was used. The collective decreased the economic effect by one half. But the case is just beginning, because at meetings with the trust and from many documents facts come out which cannot be passed over in silence.

Which innovator could guarantee with absolute precision the effectiveness of his idea? Why did not one listen closely to the statements by the person who had the most right to evaluate the necessity and the quality of such a system, Petur Rusev?

Why indeed? Was engineer Viktor Nan'ov that convincing in the position he defended during the time of the check? "This system is a mistake on Nikov's part. His opinion is radically different from that of the leadership. The method of calculating the economic effect is a documentary deceit. This system must not be implemented, and the proposal should not be examined a second time. It will lead to worsening the safety of the flights. There is no problem of coming up with 60,000 leva in hard currency, but we will not do it. The Bulgarian Civil Aviation Economic Trust has been working almost a decade on implementing an automated system for air traffic control, and this is a very petty aspect of it, which could be resolved in 99 other ways."

We will not comment on the contradictions in everything stated above, we will only note that now, in the newly created situation, Petur Rusev continues to affirm: "Perhaps the economic effect is arguable, but the social effect of the system alone is still necessary for us, because it helps the flight controllers to make decisions, and this increases safety."

Let us stop here with the facts and continue with the conclusions which result from this check. Does the director have the right to reckon that the innovators in his collective are led by profit motives? Who said, and when, that innovations must unfailingly be made only by leaders? If the system

ultimately becomes only a "petty aspect" of the whole automation system, why not help it to become a reality, since it is necessary? Is not this entire, unanimous rejection an angry and categorical reaction, provoked by a critical publication in a newspaper?

There are other facets of the position of the technical-economic council, which also cause dissatisfaction. How could the council not become acquainted with the developments? How can disinterested and unbiased people, who do not want to help with their knowledge and experience in the implementation on technical innovations, evaluate them?

The argument is not convincing, neither is the affirmation that the Air Transport Institute has been working for two decades on the problem, and now a "private" collective proposes at least a partial resolution. This should flatter the institute and the trust, for the innovations were made there, where the people want them to be.

Is it not a very obsolete notion that if the Sofia airport is not as heavily used as the largest ones in Europe, that we do not need more modern technology for flight control? If the Sofia airport is not overburdened, then why is construction of a new one needed? Perhaps it is an unnecessary luxury to have expensive radio location and radio navigational equipment, which the Air Traffic Leadership is now using for ensuring the safety of flights?

12334
CSO: 2202/22

GERMAN DEMOCRATIC REPUBLIC

IMAGE PROCESSING SYSTEMS, POTENTIAL REVIEWED

East Berlin NEUE TECHNIK IM BUERO in German Vol 29 No 1, 1985, pp 8-9

[Article by Drs. A. Geschke and R. J. Vilser--in English]

[Excerpt] Problems of Image Processing and Solutions

In the case of most image processing systems, image processing software is offered which consists of a command-controlled or menu-controlled program package or of a specific image processing program system (in most cases with a special programming language and limited fields of application). The IPU image processing program package developed by the Central Institute for Cybernetics and Information Processes of the Academy of Sciences of the DGR for the robotron A 6471 image processing system is command-controlled 2. Now that this conception has proved itself commercially viable in such fields as remote exploration data analysis, a wide variety of users, especially those working in fields other than remote exploration, are coming up with "special wishes."

The characteristic thing is that the expansion of such program packages must normally be done by system programmers. The AMBA programming system developed by the Humboldt University of Berlin for the robotron A 6471 image processing system for analysing microgrammes is an example of a programming system with a special language developed for a specific application.

The discrepancy mentioned earlier between the universality of microcomputers and their programming for special problems exists also in the field of image processing hardware, which is industrially manufactured in the GDR, available to all users engaged in the analysis of information in the form of images who wish to examine possibilities of using digital image analysis in their special lines of work at reasonable cost.

There is a myriad of such special fields of work. This also includes a future-oriented student training scheme and practice-oriented training of users of image processing technology, in order to teach them how to program simple tasks.

The yardstick of quality of a software system for image processing is not, as described in 3, whether it is command-controlled or compiler-controlled, but the flexibility with which any of a wide variety of tasks can be processed by the user. Criteria such as portability, processing time, etc., are of secondary importance.

A software package for image processing should consist of a command- or menu-controlled package of utility programs (standard image processing programs) and an interpreter- or compiler-aided easy-to-use programming system with integrated routines specifically designed for image processing. These two pillars of the software system for image processing operate with the same (standardized) data base in the form of digital matrix images.

The utility program package develops proved algorithms, which are suited for general tasks, easy to operate and economical in time, whereas programming systems are intended particularly for testing new or special problem-oriented algorithms by the user.

Tasks for new utility programs can arise from such freely programmable algorithms.

It is generally known that higher programming languages, such as BASIC and FORTRAN can be extended by routines written in assembler.

Proceeding from these considerations, BASIC, which is suited for specialists (as users, not as programmers), which is familiar throughout the world and which, on account of the vast number of home and personal computers, increasing numbers of people are becoming conversant with, has been enhanced by a number of routines, which make it possible to have unlimited access, at BASIC level, to the image processing units graphic display, trackball and Multibild, which has been standardized in the GDR, on an external storage.

This solution, realized initially on a 16-bit minicomputer, is currently being transferred onto an 8-bit microcomputer. This not only makes it possible to achieve better adaptation of image processing systems based on the robotron K 1630 microcomputer to specific tasks, but also enables users to formalize their specialized knowledge with the aid of a robotron A5120 office computer.

The possibility of formalizing specialized problems is a necessary condition for a smooth transition to using personal computers for image processing at the workplace. Personal computers with special peripherals (graphics display, trackball, etc.) supported by standard image processing programs and user-programmed algorithms, which make up the software package, are a feasible conception for user-oriented image processing in the years to come. In contrast with the common approach, problem solutions can be formalized by specialists without a programming background, and can then be incorporated into an overall system by programmers. In this way, solutions worked out independently by numerous specialists can be integrated into an expert system, which can then be used by a non-specialist for solving a problem. But in this connection we have to point out two additional problems, whose solution will have a substantial bearing on the effectiveness of image processing at the workplace.

The provision of cheap mass storage units, which can be produced in large quantities, will be a decisive factor determining the standard of performance of workplace computers. Moreover, workplace computers can be used effectively only if the primary data required for processing -- in our case images -- and all other necessary reference data are accessible. This means that the requisite computer networks and the associated software as well as data files

are not projects for the future, but something that has to be started on today. Only this way will it be possible to achieve a maximum benefit for the whole national economy by using workplace computers which will be in widespread use in the future.

CSO: 2020/226

GERMAN DEMOCRATIC REPUBLIC

GRAPHICS MODULE FOR PLOTTING CONDUCTOR DIAGRAMS

East Berlin NEUE TECHNIK IM BUERO in German Vol 29, No 1, 1985, pp 8-9
pp 8-9

[Article by J. Reinaecker: "MRES Robotron A 5601 With a Graphics Module For Plating Conductor Diagrams" --in English]

[Excerpt] A system for the digital processing of images was developed at the Central Institute of Cybernetics and Information Processes of the Academy of Sciences of the GDR (ZKI) and transferred to VEB Kombinat Robotron. Using modules of this system and of the robotron 5601 microcomputer development system, an equipment configuration and an effective program package were developed for representing, digitalizing and correcting conductor diagrams. A diagram manually sketched on grid paper is required for the automatic plotting of a new conductor diagram. When making changes, corrections have to be clearly entered in the sketch and the punched tape or the diskette recording of the last version of the conductor diagram is required.

The application was restricted to the basic land grid of 1.25 mm, conductor lines in the grid 0.05 mm or 0.0625 mm and output formats, line thicknesses and conductor paths which can be drawn on the Pracordi plotter. A characteristic coordinate is defined by four bytes:

- 13 bits for the x coordinates ($x_{max} = 400 \text{ mm}$ or 500 mm)
- 12 bits for the y coordinates ($y_{max} = 200 \text{ mm}$ or 250 mm)
- 7 bits for the side, for 15 land diameters or conductor widths, for bores and a maximum of nine special characters.

This compact representation makes it possible to load complete conductor images into the primary storage (38K bytes) and to keep them on diskettes.

Despite limitations with regard to contents, the graphics module is used by several institutions thanks to its high performance capacity.

CSO: 2020/226

GERMAN DEMOCRATIC REPUBLIC

BRIEFS

TITANIUM MICROALLOY STEEL TESTED--Controlled rolling of microalloyed construction (HSLA) steels was simulated by using a torsion plastometer. The influence of hot rolling parameters on the dynamic work softening was analyzed for a Ti-microalloyed HSLA steel as well as for an Al-killed mild steel. From the experimental results the mathematical formulation was deduced of the maximum flow stress, and the critical flow stress was deduced for the beginning of dynamic recrystallization in dependence on temperature and deformation rate. The activation energies of hot deformation and dynamic recrystallization were determined. For the Ti-microalloyed HSLA steel, static recrystallization kinetics was examined at three temperatures and at deformations corresponding to 32 per cent reduction by rolling. At 950 degrees centigrade, static recrystallization begins following static work softening of 50 per cent, which illustrates the strong retardation of recrystallization by microalloying elements. The results obtained with a Nb-V-microalloyed HSLA steel were very similar to those of the Ti-steel. [Excerpts][East Berlin NEUE HUETTE in English Vol 30 No 5, 1985 p 194]

CSO: 2020/237

POLAND

'ZAMET' LINE OF SOAKING FURNACES PROFILED

Warsaw POLISH TECHNICAL REVIEW in English No 1, 1985 pp 2-6

[Article by Andrzej Taranczewski]

[Text]

The Office for Design and Completion of Deliveries of Metallurgical Machinery and Equipment HUTMASZPROJEKT - HAPEKO, Katowice, has been specializing, among other things, in the design of furnaces. These furnaces are manufactured by the ZABRZE Steelworks, Zabrze, the MAŁAPANEW Steelworks, Ozimek near Opole, the ZAMET Mechanical Works, Tarnowskie Góry and the ZAM Metallurgical Equipment Works, Kęty. The present article gives a review of the reheaters now being manufactured.

The development of converter plants aimed at increasing the capacity of the converters has brought in its wake the need of building large-sized soaking furnaces. Until quite recently it was believed that when the furnace length exceeded 8 m, the ingots most distant from the burners tend to become insufficiently heated, owing to the fact that ingot sections coming into contact with the furnace hearth are heated up at a much slower rate.

The length and depth of these furnaces could be increased only after the application of burners with a high thermal power output (of the order of 12,000 kW) and variable flame length, and with high outlet velocities of the combustion processes. As a result of using such burners, the capacity of the furnaces could be increased up to some 200 tons. In recent years, Polish industrial works have manufactured many soaking furnaces, e.g. have equipped a large furnace shop with an annual production capacity of 4.5 million tons of

steel. Ingots weighing some 14 to 18 tons are used to charge the furnaces operating in that particular shop. The MAŁAPANEW Steelworks have provided the furnace shop at the HUTA KATOWICE Metallurgical Combine with 40 single-pass soaking furnaces with chamber dimensions 3.3 x 4.8 x 10 m and thermal power of 11,600 kW (installed load index of the burners ranges between 350...320 kW per 1 m² of hearth surface area; Fig. 1. A mixed gas with a calorific value of 7600 kJ/m³ is used at the HUTA KATOWICE Steelworks furnace shop (blast furnace gas with an admixture of nitrogen containing natural gas). This gas is burnt in burners operating at very high flue gas velocities both during the heating and reheating of the charge.

The burners flame length can be varied during both periods. Radiation / convection type metal pipe recuperators placed in the flue gas channel have been used for burning the gas. The temperature of flue gases before the recuperators is control-

iec automatically. The air to be used for combustion is heated up to some 620...670 K, while the gas is heated up to over 670 K. Heat processes in that furnace shop are controlled by means of Polish-made PNEFAL equipment (SIEMENS licence) adapted for being computer controlled. Similar single-pass soaking furnaces have been installed at the modernized furnace shop at the HUTA BOBREK Steelworks.

Technical data of the soaking furnaces: maximum output of the heating chamber for a hot charge (ca 1070 K) 30 tons/h maximum, maximum output of the heating chamber for a cold charge 12 tons/h, maximum dimensions of the heating chamber lengthxwidth-depth = 12 x 4 x 5 m, heating chamber capacity (charge weights of 30 t/200 tons), maximum charge heating temperature 1600 K, maximum heating temperatures of air in recuperators 770 K and of gas in recuperators 720 K, heat consumption

factor - cold charge 1670...2100 kJ/kg, hot charge 710...1050 kJ/kg, Fe losses as scale: cold charge 1.4%, hot charge 0.8% (approx), maximum production capacity of one chamber 135,000 tons/year.

Chamber furnaces with fixed and car-type bottoms

Chamber furnaces with fixed hearths are used commonly in forge shops and are equipped with flat-flame and vortex-type burners and, for heat treatment applications, with pulsed-type recirculating burners. All chamber furnaces are equipped with highly efficient pipe-type recuperators for preheating the air to be fed for combustion. The car-type furnaces are used both for preheating the charge prior to plastic working operations (mainly freely forged forgings) and high- and low-temperature heat treatment processes such as stress relief annealing, tempering and normalizing. These furnaces may be

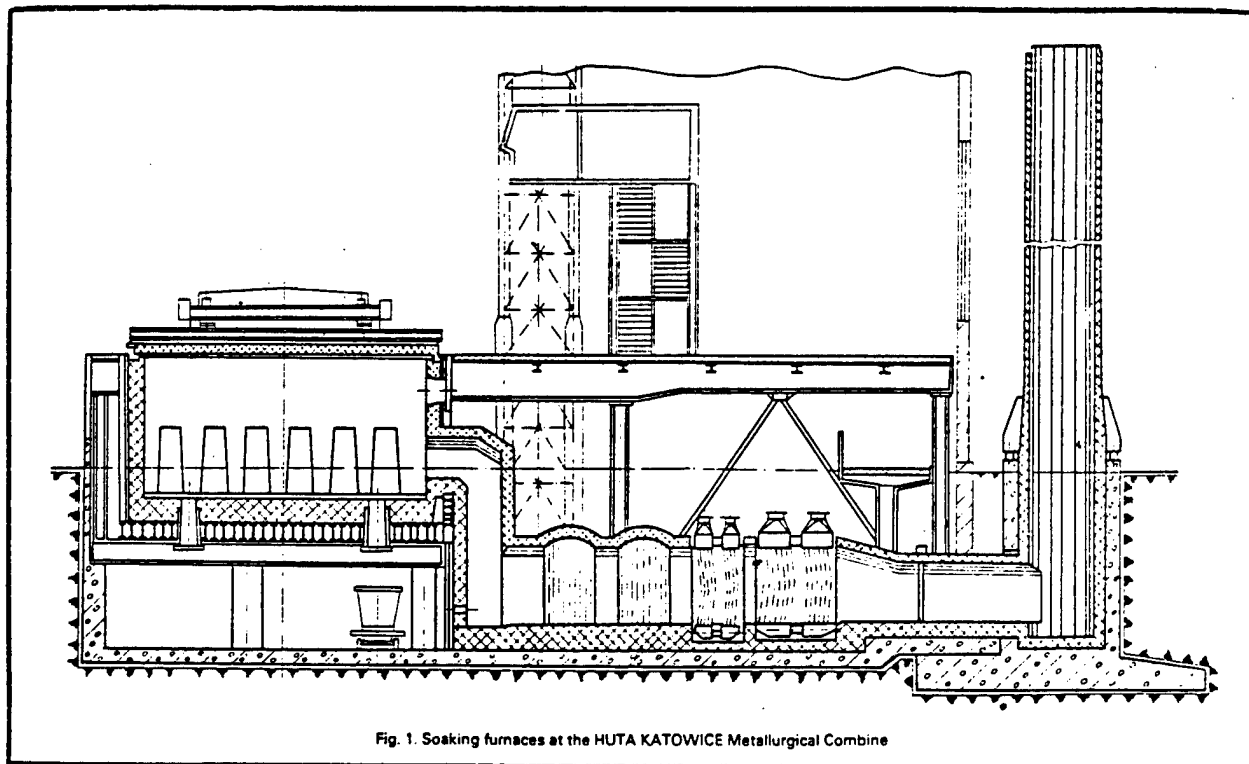

Fig. 1. Soaking furnaces at the HUTA KATOWICE Metallurgical Combine

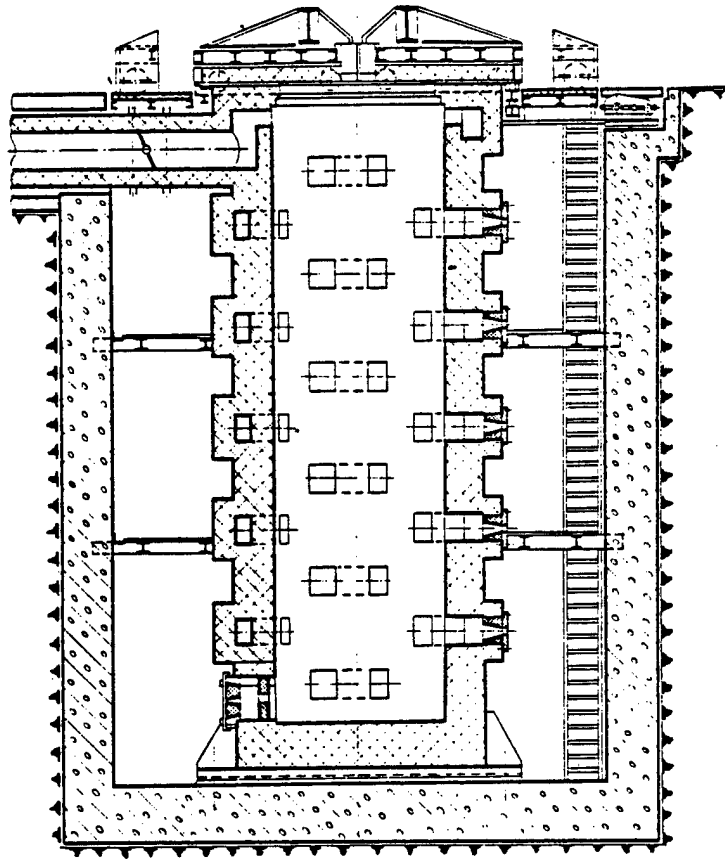

Fig 2. A shaft furnace for heat treatment processes, fitted with recirculation-type burners, at the NOWOTKO Steelworks

fitted with vortex-type, flat-flame, recirculating and pulsed-type burners. Chamber furnaces fitted with pulsed-type burners and combustion air recuperators, a novelty in that particular field, have been developed. These furnaces are lined on the inside with refractory fibrous mats with an increased Al_2O_3 content, and are outstanding for their very low heat accumulation, which makes possible the rapid heating up of the furnace together with the charge as well as its rapid cooling, both these processes proceeding with highly accurate temperature control. These furnaces are moreover provided with equipment for hydraulic pressing of the troughs sealing up the side and rear walls of the furnace against the hearth; for the hydraulic pressing of furnace doors and

maintaining them in a fixed position after opening the furnace and for mixing the gas and air before the igniter is started by means of an electric spark.

The igniters are provided with automatic flame monitoring devices; flame disappearance, occurring during the continuous switching off of the pulsed-type burners, makes possible a safe operation of the furnace.

In cooperation with the firm of EBNER, the ZAMET Mechanical Works have manufactured for the Leichtmetall-Werke, Nachterstedt (the German Democratic Republic) four chamber furnaces provided with charging and discharging equipment. These furnaces are used for the heat treatment (in a protective atmosphere) of aluminium and Al alloy strip in coils. The

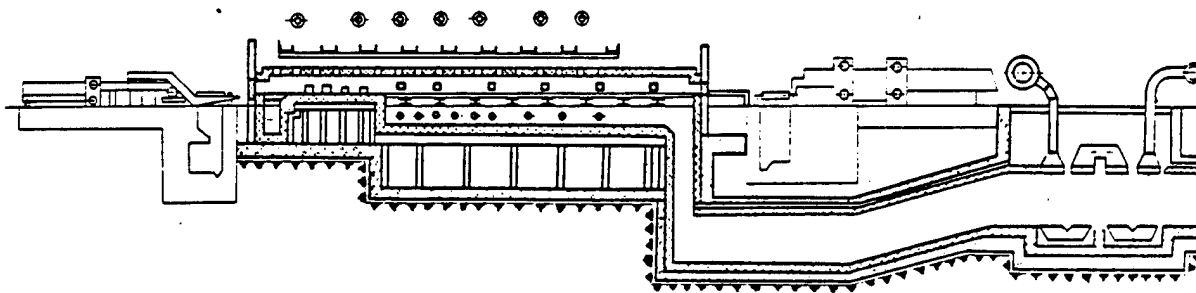

Fig. 3. A pusher furnace with flat flame-type burners installed at the BIERUT Steelworks

ZAMET Works have also manufactured chamber furnaces with a design similar to that of the furnaces installed in the GDR, for the Aluminium Works, Konin, and the Light Metals Works, Keřty.

Bell-type and shaft furnaces

In cooperation with the firm of EBNER, the ZAMET Mechanical Works have manufactured 16 electric-heated bell-type furnaces currently operating at non-ferrous metals works. These furnaces are used, e.g. by the ŁABEDY Metals Rolling Mill, the BĘDZIN Power Cables Factory, the WARSZAWA Metals Rolling Mill. They may be used for the annealing of coiled metal strip or rolled sections in coils, etc. The charge is annealed in a protective atmosphere.

The bell-type furnaces are utilized most economically when they are fitted with three furnace hearths with protective caps (bells), one heating bell and one cooling bell. In the case of such an arrangement, the charge is heated up on the first hearth, cooled down on the second, the charge being removed and charged in on the third furnace hearth.

The heating bell is taken over to the furnace hearth loaded up with the charge directly after the heating up cycle has been completed. This way of running the furnace results in a reduction of the heat losses of the heating bell.

The actual technique of furnace charging depends on the type of charge. The strip coils are placed directly on the furnace hearth, the individual coils being separated by means of supporting plates. Bars and wire in coils are placed on a rack in layers some 500...600 mm thick, separated by supporting grates.

The protective bell is placed over the loaded in charge and a vacuum pump is started to remove the air and obtain a vacuum of the order of 25...250 Pa, depending on the type of material charged and kind of protective gas employed.

The vacuum pump is switched off once the required level of vacuum has been reached, and the protective bell is filled up with a protective gas. The heating bell is then placed over the protective bell, and the furnace charge annealing process is initiated.

In addition to bell-type furnaces, many shaft furnaces (Fig. 2) with various shaft depths have been manufactured for the heat treatment of long objects. The latter furnaces are most frequently fitted with recirculation-type burners, which make it possible to obtain very uniform temperature distributions in the metal objects being subjected to heat treatment operations.

Technical data of the bell-type furnaces: charge (strip in coils) - coil outside diameter 1000 mm, maximum strip thickness 4 mm, maximum charge

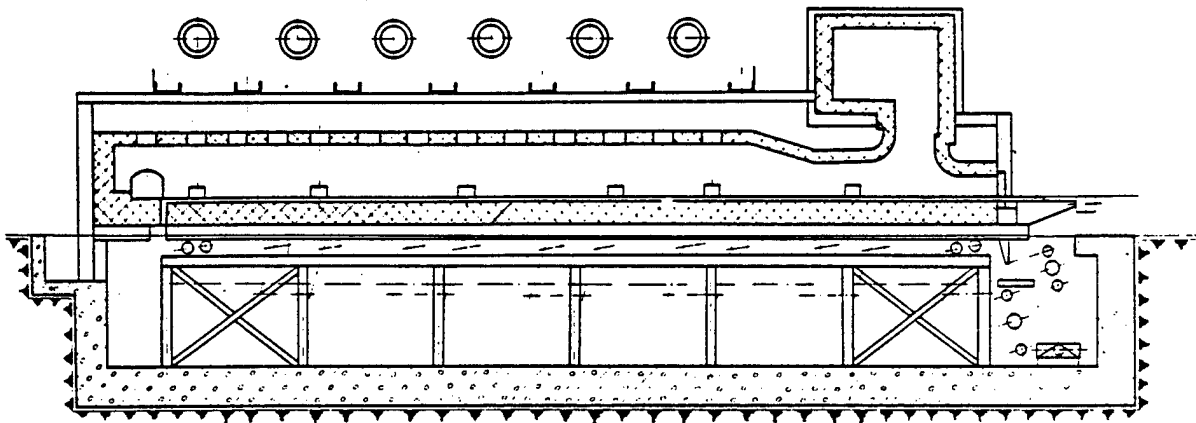

Fig. 4. A walking-beam furnace with flat-flame type burners and one-sided heating of the charge

heating up temperature 1030 K, maximum thermal power 2×180 kW, maximum installed load 500 kW.

Pusher furnaces

Pusher furnaces (Fig. 3) with outputs of up to 300 tons/h are used for the continuous heating of slabs and billets up to rolling temperatures of the order of 1380...1530 K. The maximum temperature attainable in the pusher furnaces is 1580 K. The following types of these furnaces are manufactured: pusher furnaces without heating the charge from the bottom, pusher furnaces with bottom heating of the charge and an equalizing bottom, and pusher furnaces without an equalizing bottom but with heating up of the charge from the bottom. Furnace type selection depends on the shape or on the dimensions of the charge being heated, and also on the required annealing conditions and targeted output. The length of pusher furnaces is limited by the length of skid rails (depending on the dimensions of the charge being heated), and therefore an increase of the output may be achieved exclusively by applying more intensive heating of the charge from the bottom.

The pusher furnaces with bottom heating exhibit rather large heat losses, as the skid rails along which the slabs travel are water cooled. The heat losses can be reduced using evaporator-type cooling of the skid rails. On the other hand, an advantage of these furnaces lies in the fact that their effective heating surface is considerably higher than that of furnaces that are top-heated only. A pusher furnace in which the charge is heated from the bottom, and which is not provided with an equalizing hearth, must be equipped with special skid tube covers, which prevents the formation of stains on insufficiently heated up surfaces of the charge. A significant feature of that particular furnace type is the reduction of the maximum temperature of discharging the furnace charge, down to about 1540 K.

There is a considerable demand for the heavy fuel oil-fired pusher furnaces which are used extensively in the bars and wires rolling mills in countries of the Middle East and Africa.

The HUTMASZPROJEKT - HAPEKO has built, for instance, a pusher furnace in the Arab Republic of Syria for heating charges in the form of billets with a cross-section of 100×6000 mm. This furnace has an output of some 25-30 tons/h, and its heat consumption index is very low and

equal to 1600...1800 kJ/kg.

Technical data of the pusher furnaces: maximum output 150 tons/h, maximum hearth dimensions: width 15 m, length 32 m, maximum charge thickness 420 mm, furnace-hearth loading index for cold charge 350...600 kg/m²·h.

Walking-beam furnaces

The ZAMET Mechanical Works have manufactured, in cooperation with the French firm of HEURTEY, a walking-beam furnace for heating copper billets (Fig. 4) for the Non-ferrous Metals Works SZOPIENICE. This furnace is fired with natural gas with a calorific value of 33.5 MJ/m³, and operates on a continuous basis. The charge, previously prepared on the charging table, is picked up successively by the walking hearth beams, and placed on the furnace fixed hearth either in two

rows or in a single row, depending on charge length. In case of the two-row charge arrangement, the hearth walking beams operate independently of each other and with a certain time lag between them. For the single row charge arrangement, the hearth walking beams are integrated and operate simultaneously. The charge reaches the required temperature in the temperature equalization zone situated at the end of the heating chamber. The heated up slabs are discharged one by one by means of a roller table through a hole in the furnace side wall. A uniform temperature distribution across the cross-section of the billets is attained thanks to the applied system of flat-flame burners situated in the roof and to the way of placing the billets on the hearth with a spacing of 150 mm from one another. Owing to the reheating technology employed, the heating chamber is divided into three zones: the heating up zone in

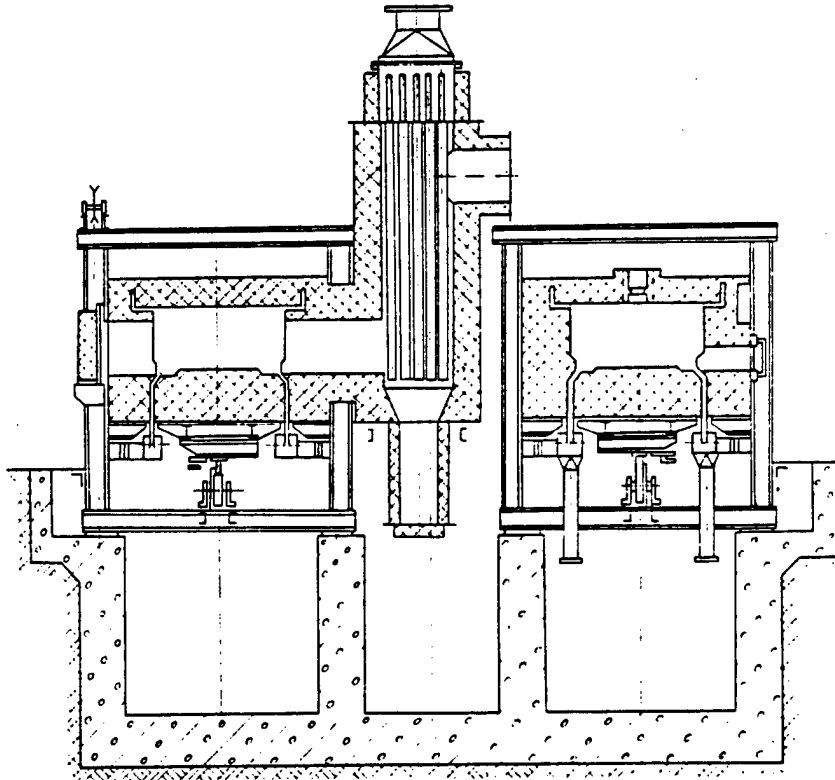

Fig. 5. A rotating hearth furnace at the forge of the SWIERCZEWSKI Steelworks

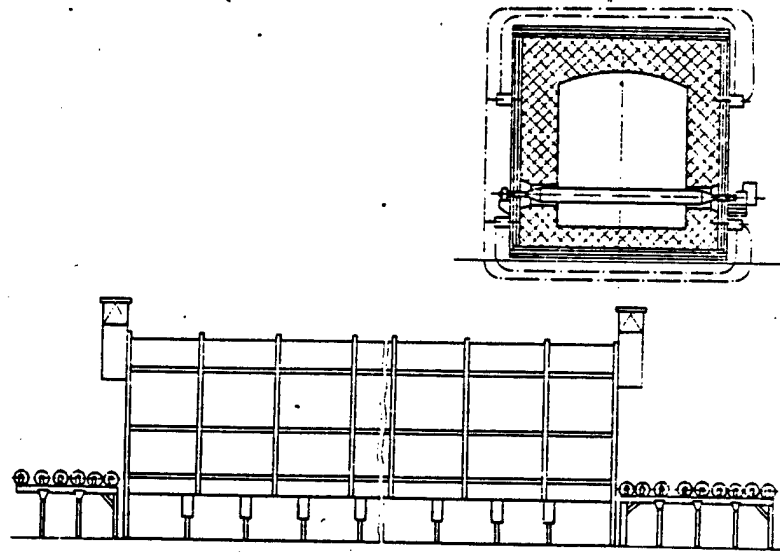

Fig. 6. A roller hearth furnace operating without a protective atmosphere.

which the charge is reheated by utilizing the heat of the outlet flue gases, the burners-equipped heating zone, and the temperature equalizing zone provided with burners (charge temperature equalization takes place in that zone).

The furnace heating system, i.e. the spacing and design of the burners, the transport of the charge, the efficient thermal insulation, and the implementation of all round heat economy and mechanical control systems, makes possible the economical running of the equipment and correct heating up of the charge, in agreement with the technological process requirements. Temperature differences obtained in the charge vary in the range of ± 5 K.

Technical data of the furnace installed at the SZOPIENICE Non-ferrous Metals Works: charge dimensions (copper billets) 110 x 110 x 1370 mm or 110 x 100 x 2900 mm, rated output 30 t/h, maximum operating temperature 1173 K, installed load 7000 kW, heat consumption 244 kW h/t, outlet flue gases temperature 673 K. The ZAMET Mechanical Works have manufactured also other walking-beam furnaces, and namely: in cooperation with BROCKMANN-BUNDT

(FRG) a walking-beam furnace for reheating brass ingots for the Metals Rolling Mill DZIEDZICE, Czechowice; and in cooperation with the French firm of STEIN-SURFACE, a walking-beam furnace for reheating steel charge to be worked into forgings (for the Lorry Factory, Lublin).

Rotating hearth furnaces

These furnaces (Fig. 5) are used for heat treatment purposes, the charge rotating round its axis during the reheating (i.e. for round cross-section charges). A dozen or so rotating hearth furnaces have been built with diameters ranging from 2 to 18 m and hearth widths of 1.5...4.5 m. Furnaces with diameters of 28.5 m and hearth width of 5.5 m have also been designed (output 90 tons/h). The unit heat consumption in the latter large furnaces ranges between 1300...1900 kJ/kg. Apart from its own design solutions, the ZAMET Mechanical Works, in cooperation with STEIN SURFACE have made furnaces with a rotating hearth for a drop forging plant in the motoring industry. The rotating hearth furnaces are equipped, like other types of furnaces, with various kinds of burners depending on heating process requirements.

Roller-hearth furnaces

According to designs developed by HUT-MASZPROJEKT - HAPEKO, and in cooperation with other firms, the ZAMET Mechanical Works have manufactured a large number of roller hearth furnaces (Fig. 6). In spite of the common name, which stems from the way in which the charge is transported by means of rolling table rolls, the furnaces belonging to that particular group do differ in their construction, which is in turn matched to individual requirements and, hence, to different technologies. The design solution of the furnace is determined by the following factors: type of charge, kind of heat treatment operation to be carried out, charge surface purity requirements after the completion of the heat treatment process, and the technique of heating the furnace. The following may be charged into the roller-hearth furnaces: tubes and bars in sections or coils, wire coils and coiled strip.

The charge is transported through the furnace continuously along the roller table. The tubes and bars in sections are placed in one or several layers, and are transported directly on roller table rolls. The charge which comes in coils is placed on pallets that are transported by the roller table.

The roller-hearth furnaces may be treated with natural gas, coke oven gas or electrically. When the gas heating system is used, and especially in the case of furnaces operating in a protective atmosphere, special burners (in the form of radially arranged pipes) are installed.

Thus, for instance, the ZAMET Works have manufactured for the M. BUCZEK Steelworks, Sosnowiec (in cooperation with the Austrian firm of EBNER) a gas-

-heated roller-hearth furnace for reheating steel tubes in a protective atmosphere.

That particular furnace has been equipped with straight, radially-arranged, jacketed tubes (double-pipe arrangement).

The charge, prepared on the charging roller table, travels at a velocity of 15 m/min to the vacuum chamber which is divided by means of two flaps; the outside one is on the charging side, while the inside one is on the side of the transition and heating chambers. The inside flap is closed when the charge is being loaded into the vacuum chamber. Immediately after the charge has been placed in position, the outside flap is also closed and the vacuum pump started in order to generate a vacuum of the order of 6 kPa. In this way the air introduced is evacuated and the remainder of emulsion and water are removed from the surface of the charge. After some 7 minutes of vacuum pump operation, the protective atmosphere enters the vacuum chamber. Equalization of the protective atmosphere pressure with that prevailing in the furnace marks the moment of stopping the vacuum pump and opening the inside flap in order to transport the charge into the intermediate chamber. The closure of the inside flap gives rise to a signal for opening the outside flap, whereupon the next cycle of loading a successive charge batch is started. The charge then passes from the transition chamber through the heating and cooling chambers at a rate of travel ensuring that the heat treatment proceeds according to the requirements of the technology applied.

The charge is removed from the furnace onto the discharging roller table at an increased rate, required to separate the

individual lots so as to facilitate the introduction of the charge into the collecting baskets.

In order to improve the tightness of the furnace, the new design solutions provide for special vacuum chambers or locks in the discharge end of the furnace.

Technical data of the roller hearth furnace: furnace dimensions - overall length 71,200 mm, heating chamber length 12,500 mm, working width 1900 mm, charging width 1750 mm, operating temperature 993...1193 K, charge travel rate through the furnace (infinitely variable control) 0.15...1.8 m/min, maximum natural gas consumption with a calorific value of 33.5 MJ/m³ - 90m³/h, protective gas consumption 80...120 m³/h. A roller hearth furnace for the annealing of copper and copper alloy wires in coils in a protective atmosphere was also built.

The latter furnace was built by ZAMET at the DZIEDZICE Metals Rolling Mill in cooperation with the firm of NASSHEUER (FRG).

Continuous and conveyor-type furnaces

The ZAMET Works have manufactured several continuous furnaces with chain conveyors, designed for the heat treatment of centrifugally cast tubes made of cast iron and for reheating the tubes prior to their being sized in tube mills.

The charge is introduced into the furnace by means of an internal roller-table and the tubes are transported through the furnace along a sloping hearth using an air and water cooled chain conveyor. The charge is unloaded from the furnace to the sizing machine by means of a roller table mounted inside the furnace.

POLAND

'ELTERMA' LINE OF HEAT TREATMENT FURNACES

Warsaw POLISH TECHNICAL REVIEW in English No 1, 1985 pp 7-10

[Article by Zdzislaw Szarapanowski]

[Text]

The ELTERMA Thermo-technical Works (LZT), Świebodzin, are a specialized maker of heat treatment equipment, and rank well up among world's largest manufacturers of that equipment. Heat treatment equipment manufactured by the ELTERMA Works is delivered to more than 25 different countries of the world, and chiefly for the motor, tool-making, aircraft, and mining machinery industries, and also for the agricultural sector. The equipment makes it possible to apply the latest heat and thermochemical treatment techniques both in controlled gas atmospheres and in vacuo. The main line of the production programme comprises equipment for the heat treatment of steel in controlled atmospheres and in vacuo. Heat and thermochemical treatment processes conducted in diffusion and protective gas atmospheres and in vacuo are finding a much wider scope of application than other heat treatment techniques used to date, owing to the good reproducibility of heat treatment results obtained in industrial conditions, simple process control and automation, and to the high surface smoothness obtained after the completion of heat treatment. The range of heat treatment equipment manufactured currently by ELTERMA is presented in this article.

Production lines equipped with the PEKAT chamber furnace

Two types of PEKAT batch-type chamber furnaces with a controlled-atmosphere are manufactured. These furnaces are electric-heated and comprise a heating chamber and an anteroom space provided with a two level lift making possible the slow cooling in a protective atmosphere and hardening in oil, with a simultaneous charging and discharging of the next charge. The furnace charge is

charged and discharged into baskets positioned on special trays, by means of a mechanical-powered chain-type pusher. Depending on technological requirements and production size, one or several furnaces are arranged in technological lines with furnaces for low- and high-temperature tempering, washing and drying equipment, and charge mechanical transport equipment.

Technological lines set up in that way may be used to carry out the following

processes: bright hardening, gas carburizing and slow cooling in a protective atmosphere, gas carburizing and hardening in oil, combined gas carburizing and nitriding followed by hardening in oil, bright annealing, coal regeneration, high-temperature tempering in the „exo“ protective atmosphere and at temperatures of up to 1080 K, low-temperature tempering in air and temperatures of up to 550 K, charge washing and drying prior to individual heat treatment processes and between operations. Furnaces for thermochemical treatment and high-temperature tempering are fed with various protective gas atmospheres produced by the atmosphere generators dealt with below.

Technical data of the PEKAT furnaces: maximum charge weight 280 kg or 560 kg (depending on type), furnace operating temperature 1225 K, cooling oil temperature: up to 350 or 450 K.

Technological lines equipped with the T-type chamber furnaces

The T-type, controlled atmosphere chamber furnaces are manufactured according to a licence supplied by the firm of IPSEN Industries Rockford (USA). The production range covers the TQF and TPFQ single-chamber continuous furnaces, the TPFQ-2 and TF-2 double-chamber continuous furnaces, and the RTPFQ single-chamber batch-type furnaces.

These furnaces are equipped with control systems and interlocks ensuring their safe operation. Their operation is fully automatic, and they may be used for conducting technological processes according to preset operating parameters. Electric- or gas-heated furnaces are available. In the case of continuous furnaces, the charge may be introduced both on the side of the heating chamber and that of the anteroom space. The TQFR furnaces (Fig. 1), a modification of the TQF furnace design, are equipped with an internal transport mechanism allowing the return of the charge from the anteroom space to the heating chamber. Similarly to the PEKAT furnaces, the T-type furnaces can be set up in a single system with the high- and low-tempera-

ture tempering furnaces, washing and drying equipment, and charge transport equipment, to give integrated technological lines.

The production lines based on the T-type furnaces ensure the realization of the same processes as those conducted in lines incorporating the PEKAT furnaces but, due to the large number of sizes and design versions available, the T-type furnaces make possible a better matching of their operating parameters to actual requirements of the users.

The TQFR furnaces can be used to conduct the pearlite reaction, an internal transport mechanism being utilized to this end.

Technical data of the T-type furnaces: charge weight 180...750 kg (depending on type), operating temperature 1273 K, cooling oil temperature 315...455 K.

Sets of the PEGat soaking furnaces

Soaking furnaces with a tight metal casing and forced circulation of protective atmosphere find application in such heat treatment processes as: gas carburizing, combined gas carburizing and nitriding, bright annealing, hardening. The ELTERMA Works manufacture 10 different sizes of PEGat soaking furnaces with a controlled atmosphere. Besides the PEGat furnace, the soaking furnaces set also comprises tempering furnaces operating at temperature of up to 973 K and with protective and natural atmospheres, water and oil-cooled quenching tanks (355 and 455 K), washing equipment, wells for the slow cooling of charge in a protective atmosphere. A typical soaking furnaces set is shown in Fig. 2.

The PEGat-700 tempering furnaces equipped additionally with a tight metal retort may be also used for conducting such processes as nitriding, oxy-nitriding, and sulfonitriding. These processes find a wide application for the heat treatment of elements which should exhibit a high wear resistance.

Technical data of the PEGat: charge weight 240...2700 kg, operating temperature 1223 K, working chamber diameter 480-1520 mm, working chamber height 690...3048 mm.

Equipment for the generation and control of diffusion and protective atmospheres

This group of equipment includes:

- the ENDO-type electric-heated endogas generators with gas outputs of 7...30 m³/h,
- electric or gas-heated generators with protective atmosphere outputs of 7...84 m³/h,
- the EGZO-type exogas generators with outputs of up to 10 and 30 m³/h,
- the US drying and UO purifying equipment for exogas, cooperating with the EGZO-type generators,
- dissociators for generating a dissociated ammonia atmosphere, with outputs of 6 and 15 m³/h,
- equipment for generating protective atmospheres from liquid organic compounds,
- dew point indicators,
- carbon dioxide controllers designed for the automatic control and recording of the carbon content.

The above enumerated pieces of equipment constitute complete protective atmosphere installations used for all types of chamber and soaking furnaces.

Car bottom furnaces

These furnaces are used for annealing, tempering, preheating and hardening of large-sized elements. The ELTERMA Works manufacture car bottom furnaces operating in a natural atmosphere. Operating temperatures vary from 1025 K to 1275 K (depending on furnace type and designation), charge weights ranging from 5 to 67 tons. The furnaces are electric- or gas-heated, with five furnace size being available for each of the above quoted operating temperatures.

Vacuum furnaces

The horizontal VFC vacuum furnaces are equipped with a single chamber, the charge being cooled in an inert gas. These furnaces are designed chiefly for hardening, annealing and hard soldering. Three furnace sizes are available, namely for charge weights of 150, 250 and 400 kg, and operating temperatures of 1500 K and working vacuum level of 1×10^{-4} Tr.

The VVFC vacuum soaking furnaces are designed for hardening, annealing and hard soldering. The available four sizes of those furnaces ensure the heat treatment of charges weighing from 180 to 1800 kg, an inert gas constituting the cooling medium.

The distinguishing feature of the VVFC (BL) vertical, elevator-type vacuum furnaces consists in the charge being loaded from the bottom onto a special mobile truck. The furnace design makes possible the hardening in a neutral gas, annealing, and hard soldering of elements that are both long and difficult to charge, with charge weights varying from 450 to 1800 kg. Operating temperature of the VVFC and VVFC/BL furnaces 1600 K.

The VDN-type horizontal, turbine-cooled vacuum furnaces are used chiefly for the hardening of tools made of high-speed steel (for cold and hot operation) and of stainless steel.

The charge may be cooled in a vacuum, by convection in a neutral gas or in a system with forced circulation of gas at pressures of up to 0.5 MPa.

Operating temperature is 1595 K, and charge weight ranges from 60 to 600 kg (depending on type).

The RVFOQ horizontal, oil-cooled vacuum furnaces are used for conducting heat treatment processes whose scope is roughly similar to that which may be achieved using the VDN-type furnaces, the only difference consisting in the hardening process being carried out in oil. The RVFOQ furnaces are of two-chamber design in which the heating chamber and the hardening anteroom space are separated by vacuum light doors. Charge weights are 150 and 400 kgs.

The VFCB horizontal, car bottom vacuum furnaces are designed for the heat treatment of heavy large-sized elements in the processes of hard soldering, annealing, hardening, vacuum degassing of metals and powder sintering.

Maximum outside dimensions of the heating chamber $b \times l \times h = 1520 \times 1820 \times 3960$ mm, charge weights ranging from 2430 to 6000 kg. These furnaces are equipped with a moving trolley facilitating the loading and unloading of the charge outside the furnace.

The 2VFC vacuum sintering furnaces operate in a „tandem“ arrangement with an integrated pumping system. The 2VFC furnaces are used for the dewaxing of die stampings and tungsten carbide sintering in the atmosphere of hydrogen. Furnace operating temperature is 1840 K, charge weights: 2 x 180 kg and 2 x 360 kg (depending on the type).

The VDFC vacuum tempering furnaces with a vacuum flushing system are designed for maintaining a bright, non-oxidized surface of elements heat treated in vacuum furnaces. In the VDFC furnaces the tempering process is carried out in an atmosphere of inert gas, e.g. nitrogen, after the air has been pumped out. The VDFC furnaces may be operated together with the basic furnaces of VFC, RV, VDN types. Operating temperature is 975 K and maximum charge weight is 400 kg.

All vacuum furnaces are equipped with automatic furnace operation control systems, which make possible the fully automatic carrying out of the heat treatment process. Furnace operation program is either preset manually using special

pre-selecting controllers, or is controlled entirely by a microprocessor-operated electric controller with a hard-wired memory making possible the programming of various heat treatment processes.

Pusher furnaces

For the purpose of big-lot and mass production, the ELTERMA Works design and deliver pusher furnace units (Fig. 4) specially adapted to match the kind of elements to be heat treated and also the actual volume of production. These furnace units operate automatically in complete heat treatment cycles and may be used for carburizing with supercooling, and heating up for hardening purposes, and also cyaniding and hardening.

These pusher furnaces may be also fitted with microprocessor-based electronic controllers.

As a result, the whole heat treatment cycle is performed automatically right up to the moment of unloading the heat-treated charge.

CSO: 2020/228

POLAND

DATA ON LAMINAR AIR FLOW CHAMBER

Warsaw POLISH TECHNICAL REVIEW in English No 1, 1985 p 17

[Text]

The KL-21 chamber with a laminar air flow manufactured by the POLON Research and Industrial Equipment Works, Poznań, makes it possible to obtain sterile air in the surrounding space, such air being indispensable in medicine, pharmacy, biological research, and also in industry during the manufacture of integrated circuits, miniaturized mechanisms or other products that cannot be contaminated with dust particles ordinarily present in air.

The KL-21 chamber incorporates a two-stage filtering system fitted with an initial filter and an absolute filter. The initial filter which is mounted in the base of the chamber catches about 75% of dust particles sucked in by the blower. The filter consists of a dismountable frame made of galvanized steel sheet in which a filter element constituted by a synthetic non-woven filter fabric is placed.

This non-woven fabric is reinforced with steel gauze and formed into regular folds increasing the effective filtering surface.

The filter is regenerated by replacing the filter element. The absolute filter is mounted in the upper section of the chamber. It can catch dust particles 0.5 μm small, its efficiency being as high as 99.97%. The

absolute filter constitutes a compact, integral unit consisting of a steel frame on which a special filter cartridge is mounted. The filter cartridge is made of a continuous filter paper strip arranged in folds separated by spacers made of suitably corrugated aluminium sheet. Thanks to the filter paper being folded, the filter itself has a very large effective filtering area in relation to its active surface. The de-dusting efficiency of this filter, as controlled by means of an electronic aerosol meter, meets the requirements of the US Federal Standard No 209 A in the 100 class.

The blowing system of the KL-21 chamber is equipped with a 0.55 kW electric motor and a drum-type blower. The rotational speed of the blower fan is adjustable, which ensures a wide range of air flow rates in the chamber working space (from 0.2 to 0.65 m/s).

The working space of the chamber is sterilized by means of a sterilamp and illuminated by a fluorescent lamp.

Technical data: direction of air flow through the working space - horizontal, power supply 220 V, 50 Hz, 0.6 kW, dimensions of chamber working space 1180 x 590 x 550 mm, overall dimensions of the KL-21 chamber 1270 x 1500 x 890 mm, weight 260 kg.

CSO: 2020/228

POLAND

DESIGN ENGINEER ON DEVELOPMENT OF PULSED HEATING FURNACES

Warsaw POLISH TECHNICAL REVIEW in English No 1, 1985 pp 26-28

[Interview with Kazimierz Suchon by Andrzej Taranczewski]

[Text]

Kazimierz Suchoń, born on March 4-th, 1923, got his engineering degree from the Silesian Technical University of Gliwice, specializing in the construction of heat furnaces. Since liberation, he has been working all the time in his discipline as an employee of, successively, the Enterprise for the Construction of Industrial Furnaces OSTOFEN, the Metallurgical Industry Design Office BIPROHUT, and, finally, of the HUTMASZPROJEKT-HAPEKO Design Office for the Completion of Deliveries of Metallurgical Industry Machinery and Equipment.

For his pioneering achievements in the design of heat furnaces, he has been awarded numerous prizes, including 3-rd degree State Team Prize in 1952, the Award of the Minister of Heavy Industry in 1963, the Award of the Chairman of the Committee for Science and Technology in 1970, the 2-nd degree Team Prize of the Chief Technical Organization in 1975.

Andrzej Taranczewski: Different design solutions of furnaces with pulsed-type heating systems have been already presented in various technical journals. Do you think that further progress is being made in that particular field?

Kazimierz Suchoń: Yes, of course, the technological progress is quite distinct today both in the design and production of furnaces of that type, and particularly of box-type furnaces fitted with fixed or

car bottoms, such furnaces being equipped with high flue gas outlet velocity burners controlled by on-off systems. Furnaces with the pulsed-type heating system are used for heating up the charge prior to its being subjected to plastic forming and also for heat treatment purposes due to the highly accurate temperature control and uniform temperature distribution obtained in them.

A.T. Such a prototype furnace was built in 1980 at the Racibórz Boiler Factory RAFAKO. That furnace is used for the heat treatment of elements measuring 4000 x 4000 x 1400 mm and weighing up to 300 tons, and finds application in power industry, including the nuclear power engineering sector. For 2 years now that furnace has been used for stress relief annealing (at about 870 K) and normalizing purposes (carried out at 1220 K). Would you like to comment on that.

K.S. We designed that prototype in such a way as to ensure the attainment of a wide range of heating possibilities. In order to achieve an optimum uniformity of the heating cycle, we decided to divide the furnace into four independent, automatically controlled heating zones. The pulsed-type burners were arranged in six groups round the circumference of the furnace chamber so that either right-hand or left-hand sided circulation of the flue gases may be obtained within the space being heated, by a suitable periodic switching on and off of individual groups of burners.

A.T. And what have the results of your operating experience with those furnaces indicated?

K.S. We found that it was possible to attain in the final heating phase a charge temperature distribution uniformity much better than ± 10 K. Such uniform temperature distribution was also achieved by having the top burners switched on, and also when the possibility of changing the direction of flue gases circulation (to the left or right) had not been made use of. Relevant tests indicated moreover that the furnace charge can be heated up according to a pre-determined heating curve, while maintaining the required temperature distribution uniformity, by varying the amount of the fuel gas and combustion air fed, i.e. without using the „on-off“ operation mode of the burners. These possibilities are due to the stability of the flame of the pulsed-type burners operating in the range of some 40...100% of their rated power.

A.T. What design solutions were introduced in the prototype furnace?

K.S. The following design solutions were incorporated in that furnace:

- car bottom and furnace door were additionally sealed in the closed position,
 - the pulsed-type burners were provided with tunnel-type tapered combustion chambers positioned outside the side walls of the furnace,
 - the pulsed-type burners were fitted with electric-ignited gas igniters equipped with a flame detecting device,
 - electrically operated valves were incorporated in the heating process automation system for controlling the on-off cycle of the pulsed-type burners and for the reverse-mode switching of the circulation of the flue gases inside the furnace chamber,
 - an intermittent flue gases exhaust system was applied in order to maintain an optimum, constant positive gauge pressure inside the chamber.
- Experience acquired during the construction, start-up, and day-to-day furnace operation was utilized in the development of designs of further furnace versions provided with the pulsed-type heating system. New types of car bottom furnaces were developed, chiefly for the heat treatment of chemical plant equipment

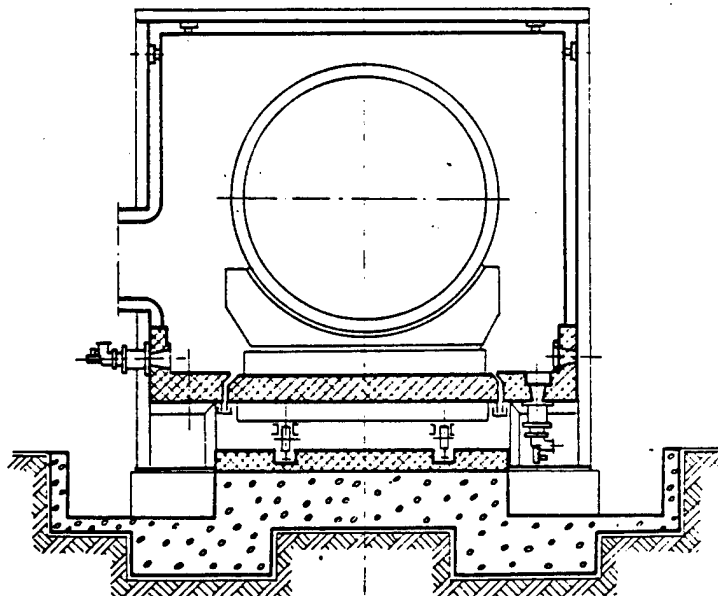

Fig. 1. Car bottom furnace for the heat treatment of chemical plant and power industry equipment

and power industry equipment, and also fixed or car bottom furnaces for heating and heat treatment purposes at forge and press shops. All these furnaces are guaranteed to achieve a uniform temperature distribution in the final heating phase ($\pm 5 \dots 10$ K uniformity), depending on actual technological requirements.

A.T. Would you like to describe in greater detail the car bottom furnaces used for the heat treatment of the various components of chemical plant and power industry equipment?

K.S. That particular group of furnaces is outstanding for its large chambers making it possible to conduct controlled heating and cooling of charges that are both very heavy and of large size. Our firm developed three such heat treatment

furnaces operating at temperatures in the temperature range of 850...1220 K. Charging space dimensions and charge weights of these furnaces are as follows: 4500 x 4500 x 11,600 mm, 150 tons; 4500 x 4500 x 16,000 mm, 150 tons; 6500 x 6500 x 20,000 mm, 300 tons.

The 4500 x 4500 x 11,600 mm furnace is also adapted for conducting solution heat-treatment (hyperquenching) operations at temperatures of up to 1470 K. Three such furnaces are currently being built at the METALCHEM Chemical Apparatus Works, Opole. These have been equipped with four groups of burners (Fig. 1), and do not feature the flue gases circulation direction changing option (i.e. to the right, or to the left). However, the number of automatic control zones has

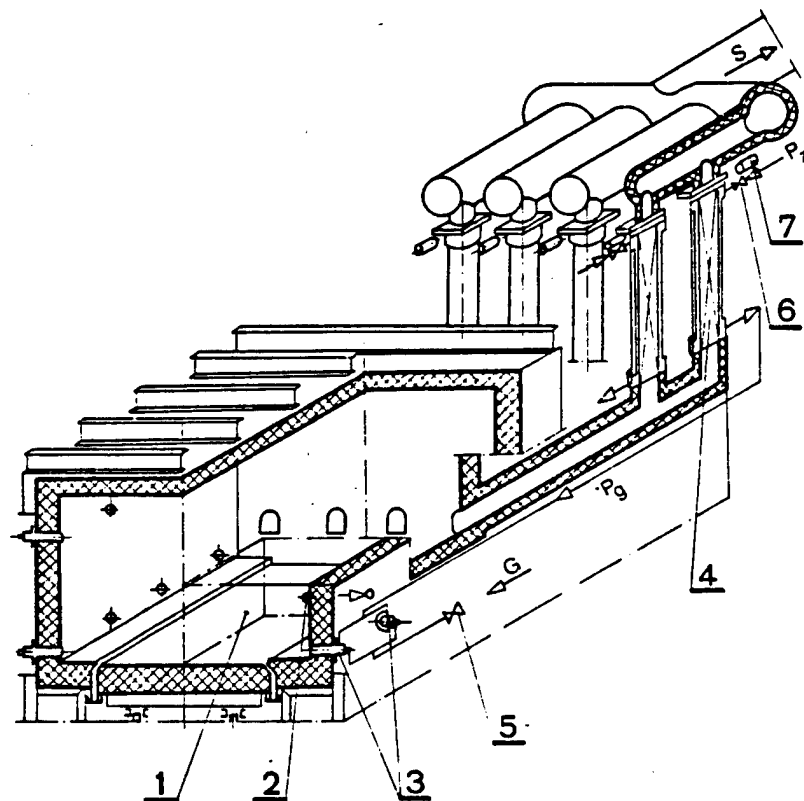

Fig. 2. Car bottom furnace for the heating and heat treatment operations carried out in forge and press shops: 1 - heating assembly, 2 - thermoelements, 3 - burners, 4 - recuperators, 5 - gas stream electrically operated valves, 6 - air stream electrically operated valves, 7 - equipment for the automatic switching on or cutting off the flow of flue gases through the recuperator.
G - fuel gas, Pz - cold air, Pg - hot air, S - flue gases.

been increased in order to attain a better temperature equalization effect in the system. Owing to the elimination of the top burners, it was necessary to introduce in that heating chamber section the air nozzles used during the heat treatment operations carried out with controlled furnace charge cooling. Moreover, in order to achieve an optimum temperature equalization in the heating zone, and particularly at different charge characteristics, it was decided to provide the possibility of switching on and off the horizontal and vertical burners by suitably modifying the temperature control systems of each heating zone. As a result, it is possible to achieve a heat distribution in the heating chamber that is particularly suited for any given application requirement.

The following design changes, providing an improvement over the previous solutions, were implemented:

- side walls, roof and doors were lined with fibrous, refractory materials in the form of mats; as a result - in comparison with the traditional furnace linings based on solid refractories - the lining thickness has been reduced nearly twice and its weight about tenfold, while the heat accumulation has risen some twenty times. In fact, the traditional refractory materials have been used only in the construction of the furnace bottom and lower sections of the side walls, accommodating the burners; the introduction of fibrous refractory mats has resulted in reducing the total weight of the furnaces by more than a half.
- furnace bottoms were sealed by means of special troughs filled with a loose refractory material, the troughs being raised and pressed hydraulically against elements of side walls and furnace bottom,
- in order to increase the tightness of furnace doors, the latter are moved and pressed home hydraulically in the closed position, and controlled hydraulically in the opened position, which prevents the doors from falling down should the door mounting collapse,
- the automatic heating process control system has been equipped with special electrically operated valves making possible the remote switching on and off of the individual pulsed-type burners,

- the heating process is controlled automatically using a dedicated programming device,

- simple installation with all measuring instruments and equipment installed in the fuel gas and combustion air pipelines improves greatly the control of heating power output of individual burners, while ensuring the correct gas to air ratio.

In this particular version of the pulsed-type heating system furnaces, recovery of the heat of flue gases is not envisaged. Relevant analyses indicated the unprofitability of providing those furnaces with recuperators in view of the fact that heat treatment operations are generally carried out with the cooling of the charge inside the furnace, and also due to the periodic operation of those furnaces.

A.T. Would you like to say a few words about the fixed or car bottom-type furnaces designed for heating up and heat treatment operations carried out at forge and press shops?

K.S. Our firm has designed and delivered several charge heating up and heat treatment centres to be used at the press shop of the METALCHEM Chemical Apparatus Works, Opole. The quenching and tempering centre is provided with two fixed bottom, box-type furnaces for hardening and tempering, and one tempering furnace. All these furnaces are charged by means of an overhead-type charger designed by our firm. Bottoms of all furnaces have the same dimensions: width 3000 mm; length 3000 mm. These furnaces are adapted for the heat treatment of drawpieces weighing up to 750 kgs at the temperature of 1200 ± 10 K. In the quenching and tempering furnaces the charge is charged and discharged both on the side of the stamping press (by means of a travelling manipulator) and also, by means of the overhead-type charger, on the hardening press side. The heating up and heat treatment centre is equipped with one car bottom furnace with the following dimensions: width 6000 mm, length 7800 mm; the permissible furnace bottom load being equal to some 35 tons. In this furnace it is possible to heat up the charge up to 1420 ± 10 K prior to its being subjected to plastic forming in a press, or to heat treatment conducted in the $870 \dots 1220 \pm 10$ K temperature range. Both in the

fixed bottom and the car bottom furnaces the charge is heated up on both sides in eight and twelve (in the case of the car bottom furnace) heating zones provided with automatic systems controlling the basic parameters of the process. Each heating zone constitutes an independent heating unit provided with high flue gas outlet velocity burners fitted with gas-type igniters, a heat recovery unit, electrically operated valves for the automatic switching of the burners on and off, and also equipment for the automatic cutting off the flow of the flue gases, should the gas supply be cut off. Uniform heating up of the furnace charge is ensured by the division of the furnace chambers into many heating zones, and also by the independent, automatic operation of all these zones.

A.T. I think our readers would be interested in a graphical presentation of the problems discussed.

K.S. A typical example is provided in this case by the car bottom furnace designed for the heating up and heat treatment operations carried out at forge and press shops.

The pulsed-type heating system installed in an eight-zone, car bottom furnace is depicted in Fig. 2. This furnace is equipped with a flue gases heat recovery unit, and each heating zone constitutes an independent, automatically controlled heating assembly 1 incorporating the thermoelement 2. In the heating zone proper there are mounted two high flue gas outlet velocity burners 3 adapted for gas combustion using hot air that has been heated up by the flue gases in the heat recovery unit (recuperator) 4. Each heating assembly incorporates electrically operated gas and air valves (5 and 6, respectively) for the automatic switching on and off of the burners as well as the special device 7 whose operation is synchronized with that of the valves in order to automatically switch on or cut off the passage of flue gases through the recuperator. The introduction of inter-

mittent removal of the flue gases from the individual heating zones of the furnace makes possible an optimum utilization of the heat content of the flue gases, while protecting the recuperators against being overheated when air flow is cut off.

The pulsed-type heating system is a novel design solution implemented in furnaces used in forge and press shops. In that system, the gas combustion process proceeds with the utilization of hot air, heated up to temperatures exceeding 770 K in the recuperators, which considerably enhances the thermal efficiency of the heat furnaces used in forge and press shops and, hence, results in significant fuel savings.

We have developed a large number of design versions of those furnaces so as to meet the requirements of different manufacturing conditions. While continuing our design work we are also engaged in modernizing furnaces equipped with high flue gas outlet velocity burners controlled in the „on-off” mode. Also well under way is our work on the application of a programmable digital control system for the automatic control of heating process.

It may be stated, on the basis of experience already acquired, that the economical and correct operation of the furnaces with the pulsed-type heating system depends chiefly on the following factors:

- optimum division of the heating space into independent heating zones,
- application of highly efficient burners with suitable ignition systems,
- highly reliable operation of measuring instruments and program-controlled equipment used for the monitoring of the heating process,
- optimum selection of refractory materials for the lining of heating chambers,
- type and arrangement of the recuperators whose installation should be determined on the basis of worthwhileness analysis.

A.T. Thank you for the interview.

POLAND

NEW PRODUCTS IN CHEMISTRY, METALWORKING, ELECTRONICS, OTHER FIELDS REPORTED

Warsaw POLISH TECHNICAL REVIEW in English No 1, 1985 Supplement pp I-VII

[Excerpts] Rigid Polyurethane Foams From Industrial Wastes

Polyols are the main components indispensable for the manufacture of rigid polyurethane (PU) foams. A most economical method of obtaining the polyols has been developed at the Institute of Polymers, Polish Academy of Sciences, Zabrze (Polish Patent No. 119480). The application of this technology yields aromatic-amino-aliphatic polyols starting from phenolic compounds constituting waste or by-products formed during the industrial process of phenol manufacture. These polyols make possible the production of rigid flame-retardant PU foams and polyurethanecyanurate foams. Their application results in a reduced consumption of expensive amine catalysts and fire retardants. Two types of polyols have been developed: Rokopol FF, obtained from crude o-phenylphenol, and Poliol KF derived from cumene-phenol tar. The polyhydroxyl tertiary amines present in those polyols make it possible to conduct the process of polyaddition with polyisocyanates in an autoclave, so that the amount of the amine catalyst indispensable for the manufacture of PU foams is very small indeed. The aromatic structural units present in those polyols ensure that PU foams manufactured using them exhibit an excellent heat resistance and good mechanical strength properties.

The Rokopol FF and Poliol KF are particularly useful when the PU foams are made by the spraying technique.

Technical data (respective values are quoted for the Rokopol FF and Poliol KF): hydroxyl number 500 ± 30 mg KOH/g; maximum water content 0.1% by weight,

viscosity at 298 K 7,000...15,000 and 10,000...15,000 mPa.s; density at 298 K 1.08 = 0.04 g/cm³

The compressive strengths of the PU foams manufactured using those polyols range from 215 to 290 kPa (in direction parallel to that of growth), and from 85 to 120 kPa (in direction perpendicular to that of growth), heat resistance after DIN 53424 443...453 K.

TECHNOLOGY
OF SULPHITE PULP MANUFACTURE

A new technology of producing sulphite pulp from sprucewood (Polish Patent No. 116192) has been developed at the Technical University of Łódź. This technology features a number of advantages, such as improving the yield of wood pulp and increasing its mechanical strength parameters while reducing the amount of unpulped wood (partially cooked chips) and producing a high degree of delignification. Pulping time has been also reduced significantly. Thanks to the application of this technology it is possible to reduce considerably the amount of plant equipment required in sorting and bleaching plants. Sprucewood chips some 0.5...5 m thick (optimum thickness - 1 mm) are pulped by means of a digesting liquor constituted by an aqueous solution of calcium, magnesium or sodium bisulfites with an excess of dissolved, free sulphur dioxide at an elevated temperature of about 310 K. The pulping process is conducted to reach a degree of delignification not smaller than 15, as expressed in terms of KAPP's number. The pulp thus obtained is washed, sorted and bleached.

Depending on the thickness of chips, the cooking at a maximum temperature lasts from 4 to 6 hours, the yield of fibers ranges from 44 to 48% and their whiteness degree from 40 to 71%, and the amount of partially cooked chips from 0 to 8% of the starting stock material.

Mechanical strength indices at 50° SR are as follows: self-tearing 8000...10070 m, relative burst 4.6...6.2 kPa·m²/g, relative tear resistance 9.9...11.7 mN·m²/g, number of double folds 920...1380.

MODIFICATION OF MINERAL FILLERS FOR THERMOPLASTIC POLYMERS

Mineral fillers are added in order to improve the useful properties and processability of thermoplastic polymers. However, the technologies employed so far for that purpose, make possible the improvement of the useful properties of those materials with a simultaneous deterioration of processability, or vice versa.

The technology of modifying the mineral fillers, developed at the Centre for Molecular and Macromolecular Studies, Polish Academy of Sciences, Łódź, has eliminated that drawback (Polish Patent No. 120692, US Patent No. 4 411 704). Prior to being mixed with the thermoplastic polymer, the mineral filler is coated with a thin layer of an oligomer of ethylene oxide. The mass thus obtained is dried at 320...470 K. When the polymer is processed at temperatures of up to 520 K, the ethylene oxide oligomer does not decompose and remains in a liquid state. It wets the polyethylene well and also a number of such fillers as: talcum, silica, chalk or kaolin. The liquid form of the ethylene oxide oligomer is particularly advantageous in view of the possibility of a reproduction of broken adhesive bonds. It is moreover possible to control the mechanical properties by changing the amount of the added oligomer. Polymeric materials manufactured using the mineral fillers modified in the way described, exhibit a lower modulus of elasticity, an unchanged tensile strength, an increased elongation at break, and also a higher impact strength. The low cost and accessibility of the ethylene oxide oligomer and finish are its additional advantages.

IMPROVEMENT OF CELLULOSE TEXTILE FABRICS

A technology of improving textile fabrics containing at least 20 per cent cellulose has been developed at the Technical University of Łódź (Polish Patent No. 122810). This technology makes it possible to obtain fabrics with a high wrinkle resistance both in a dry and a wet condition. These fabrics practically do not crumple in wear and do not have to be pressed after washing.

The cellulose-based textile fabrics are padded with aqueous solutions of N-methylol acrylamide or N-methylol methacrylamide, dried, and irradiated with an ionizing radiation dose equal to KGy, the padding process involving the use of a solution of a catalyst constituted by a strong acid or its salt at a concentration ensuring the attainment of a solution of pH value lower than 3. Drying and rinsing are the final operations. Two chemical reactions take place in the course of the technological process described, namely the polymerization of the vinyl groups of the monomer, initiated by cellulose macroradicals formed due to the action of the ionizing radiation applied, and the condensation of the methyl groups of the monomer grafted on the cellulose molecules with the hydroxyl groups of the neighbouring cellulose chains, which results in the formation of a crosslinked cellulose fabric with non-crumpling properties. Both reactions proceed at a fast rate, which makes it possible to conduct the process as a continuous one. It is also possible to introduce dyes as well as wetting and softening agents to the solution, in order to improve the secondary qualities of cellulose fabrics.

A PLASTIC MATERIAL FOR ROLLER CASINGS FOR TEXTILE INDUSTRY MACHINES

Technology of manufacturing a new plastic for the production of roller casings to be used in textile industry machines has been developed at the Technical University of Łódź (Polish Patent No. 117855). This new material is outstanding for its low compression set, small coefficient of friction, considerable swelling in water and lower electric specific and surface resistivities. Its properties are comparable

in all respects to similar materials manufactured by world's renowned firms.

The masterbatch is made either from rubber or a mixture of rubber with a plastomer, a filler, an inorganic pigment, a hydrophilic agent, an anti-static agent, a vulcanization activator and a condensation resin the whole being compounded at temperatures of 330...470 K for some 0.5 to 2 minutes.

A crosslinking agent, a vulcanization accelerator, an antioxidant and an inorganic pigment are added to the masterbatch. The whole is then mixed for some 2 or 4 minutes at temperatures ranging between 290...410 K to obtain a uniform stock subsequently cured in a press or an oven.

The presented technology of manufacturing this new material for roller casings is very simple and the production process may be carried out in standard chemical plant equipment for the compounding and mechanical processing of polymeric mixtures at elevated temperatures. This material has a hardness of 78 Sh, a compressive set of 5.6%, a static coefficient of friction on glass equal to 0.5, swelling in water at 298 K - 25%, surface specific resistivity of $10^{10} \Omega$ (at a relative humidity of the air equal to 75%). Production of that new plastic material has been started at the ELTECH Works at Bielsko-Biala, and the Experimental Plant of the Institute of the Rubber Industry STOMIL Łódź.

A MAGNETOMETER

A magnetometer making possible the measurement of magnetic moments of the order of 10^{-13} Wb.m has been developed at the Technical University of Kielce (Polish Patent No. 121361). This instrument is designed for measuring the extent of magnetization or the magnetic susceptibility of magnetic substances, and features a number of advantages, such as high sensitivity, small measuring error, a relatively low cost, stability of measurements and is also very simple to operate. This magnetometer may be used both in scientific research laboratories and in industry.

The principle of its operation consists in measuring the period of oscillation of a compound pendulum in which there is placed a sample of the substance being tested. That sample is situated either in

an external magnetic field with a constant value of the product of its intensity and z-component of its gradient ($H \cdot dH/dz = \text{const.}$), or that magnetic field is switched off. The physical pendulum made from a non-magnetic material is connected with a clock-type drive system and a gear computing the number of oscillations of the pendulum, the gear being connected to a pointer and a stop clock. The end of the pendulum housing the sample being tested is situated between pole pieces of an electromagnet. The pendulum is situated inside a cryostat, and the sample is provided with a heater, which makes it possible to carry out measurements over a very wide range of temperatures.

A portable version of this magnetometer, with a slightly lower sensitivity, has been also developed for the purpose of rapid and non-destructive determination of the content of magnetic metals in geological samples. The portable version of this magnetometer may be used for in-field geological and geophysical testing purposes.

A PROFILE MEASUREMENT GAUGE

The PM-03 profile measurement gauge developed at the Institute of Machining, Cracow, is designed for measuring the surface roughness parameter R_a on flat surfaces with a minimum length of 6 mm, and on outer and inner cylindrical surfaces with diameters greater than 10 mm. Owing to its high measuring accuracy, it may find application in both workshops and laboratories. The PM-03 instrument is of modular construction and is equipped with a measuring head which moves along the surface being tested, through the intermediary of a drive system. During the travel of the measuring head, the surface unevenness produces vertical motions of the mapping blade. The motions of the blade are transferred by means of a system of levers to the core of an inductive converter operating on two edges of its characteristic and supplied by a generator. The signal from the converter is amplified, fed to a band filter, amplified again and fed to a demodulator controlled synchronously via the generator by means of a rectangular signal. The demodulated signal is amplified again, filtered by a low-pass filter and, after being amplified again, is fed to an indicator of

levelling the measuring head and a system of cut-off filters, and finally, to the *Ra* surface roughness parameter counter. The measurement result is read off on an analogue basis.

Technical data: measuring ranges 0.05 : 0.1 : 0.25 : 0.5 : 1.0 : 2.4 : 5 : 10 and 25 μm , accuracy 10%, maximum travel distance of the measuring head 50 mm, radius of curvature of the diamond tip of the mapping blade 2.5 μm , cut-off filters 0.08 : 0.25 : 0.8 : 2.5 : and 8.0 mm, power supply 220 V, 50 Hz.

AN ASH-CONTENT METER

The ash content meter developed at the EMAG Scientific and Production Centre for Mining Industry Automation and Electrical Engineering, Katowice (Polish Patent No 121313) makes possible a rapid measurement of the ash content of coal by a radiometric method.

This instrument makes possible the testing of the whole mass of the sample by means of a narrow radiation beam. The measurement results are independent of the instantaneous surface density whose average value remains constant throughout the measuring cycle. Other advantages of that instrument include: a low measuring error due to the inhomogeneity of the material and the fact that there is no need of making the layer even prior to measurements.

Principle of operation of this instrument consists in measuring the nuclear radiation intensity attenuated by the sample of the material being tested. The sample is placed in a horizontal, cylindrical measuring vessel fitted with a vertical, axially mounted baffle. A collimator and a detector are placed perpendicularly to the axis of that vessel, both being in a fixed position with respect to each other. The measuring vessel executes a reverse screw motion a few times during the measurements. The instrument is calibrated prior to measurements, the calibration dependence being a relation between the number of detector pulses counted and the ash content of samples with a known composition. The Am-241 radioactive isotope with a quantum energy of 60 keV and an activity of 1.85 GBq is used as the source of radiation. The measuring vessel is made of thin organic glass and has a diameter of 100 mm and is 200 mm high. A scintillation probe with an NaJ/Tl crystal is the detector used. The ash content of between 0 and 30% may be determined using that instrument which has been

used successfully in a number of Polish coal mines for the rapid determination of the calorific value of a hard coal batch.

MEASUREMENT OF MATERIALS HYDROGEN CONTENT

The STANISŁAW STASZIC Academy of Mines and Metallurgy, Cracow, has developed an original piece of isotope equipment for measuring the content of pure hydrogen and hydrogen-containing compounds in materials of different chemical composition, irrespective of the physical state of the given material (Polish Patent No. 122980). It has found a wide application for determining the content of asphalt in bituminous masses used for road and airstrip construction purposes. It is also suitable for testing the ores of metals, and determining the moisture content of the soil, etc. Its advantage lies in an easy preparation of samples for measurements, owing to the fact that a relatively small mass of the sample is required, and that the geometrical shape of the sample is convenient for measuring purposes. The equipment does not present any hazard to its users, and makes it possible to determine very quickly and with sufficient accuracy the content of e.g. asphalt in hot bituminous masses, which in turn facilitates the control of the manufacturing process by which those masses are obtained.

Principle of operation of this equipment is based on the utilization of the phenomenon of the thermalization of neutrons taking place in the sample being tested. The equipment is fitted with a body made of TARNAMIDE „B”, a type Pu-Be source of fast neutrons with an efficiency of 5×10^8 neutrons/s being housed in the body. It is moreover fitted with a measuring probe connected with a feeding and recording circuit, the probe incorporating, among other things, a detector of thermal neutrons. Between the source of fast neutrons and the detector there is a measuring chamber into which the sample to be tested is introduced. In order to determine the amount of asphalt in the bituminous mass, the equipment has to be calibrated using reference samples with a known asphalt content.

MEASUREMENT OF HEAT EFFECTS IN THIN LAYERS

Differential thermal analysis (DTA) makes it possible to obtain a number of significant pieces of information in investigations of properties of thin metallic, dielectric and semi-conducting layers.

An original method of measuring heat effects in those layers has been developed at the Technical University of Warsaw (Polish Patent No. 118961). This method ensures a higher measuring sensitivity than the techniques applied so far. This technique has been used for studying thin layers of amorphous selenium samples and also those of germanium tellurides and selenides. A set of thin-layer type temperature measuring probes is deposited on a chemically inert base (a quartz plate) by coating it with metallic layers of different metals (e.g. bismuth and silver) constituting thermocouple junctions.

In order to limit the effect of the base and to achieve an adequate electric insulation, those junctions are coated with a layer of a neutral (inert) material (e.g. silica). Such temperature sensors exhibit a negligibly small thermal capacity. The layer to be studied is deposited on one of the junctions, the quartz plate material acting as reference. After the application of the layer to be tested, the whole is placed inside a furnace with a linearly increasing temperature gradient. A voltage proportional to the temperature difference between the thermocouple junctions is thus produced between the contact field of the plate. That voltage is recorded by means of a suitable recording device providing a thermogram representing very accurately the heat effect occurring in the layer being studied. The layer is kept inside the furnace for some 45 minutes.

A BATH FOR CATALYTIC NICKEL PLATING

The bath for catalytic nickel plating CHEMONIKIEL-95, developed at the Institute of Fine Mechanics, Warsaw, features a number of advantages unknown in the case of baths used so far. This bath ensures a very high nickel plating rate ranging from 2 to 6 $\mu\text{m}/\text{h}$, depending on the purity of raw materials and the extent of bath spending. This bath may be

regenerated many times over, and the nickel plating process may be conducted in tubs made of acid resistant steel, thanks to the addition of suitable inhibitors to it (traditional baths are used in tubs made of plastics, glass or ceramic materials). It may be moreover used for the direct nickel plating of aluminium and its alloys. The nickel plating process is conducted in equipment fitted with an automatic system for bath regeneration, which ensures the replenishment of bath components as they are being used up. Coatings obtained using the CHEMONIKIEL-95 are amorphous and constitute, from the physical point of view, a supercooled liquid. The amorphous structure of the coatings results in their exhibiting an increased corrosion resistance. The hardness of the coatings ranges between 500...550 HV, which corresponds to the lower hardness limit of a chromium coating, and their plasticity reaches 2% and may be increased up to 6% and more by suitable heat treatment. These coatings feature a good solderability and maintain it for a long period of time. They may be coated with other coatings, i.e. they may be silver, gold- and chromium-plated, etc.

The CHEMONIKIEL coating thickness is practically unlimited, but the application of coatings thicker than 120 μm is economically unsound. The smoothness and brightness of these coatings is the same as that of the base. This nickel plating bath has found application, for instance, in the manufacture of printers.

GOLD PLATING BATH

A number of technologies of manufacturing gold plating bath solutions used for depositing gold coatings for technical or decorative purposes have been developed at the Institute of Fine Mechanics, Warsaw (baths IMPEX-ZF, IMPEX-ZG, IMPEX-ZN, IMPEX-ZNA and IMPEX-ZNS). The IMPEX-ZF bath is used for preliminary gold plating and makes it possible to obtain a prime coat ensuring good adhesion to the main coat. Concentration of gold in that bath ranges from 1.0...3.0 g/l, cathode current density 0.5...1.5 A/dm², pH 3.5...4.5, bath temperature 323...328 K.

The IMPEX-ZG bath is used in the electrical and electronic industries for gold

plating contact elements, and also for decorative purposes. The obtained coatings have small own stress values, and their micro-hardness is of the order of 160...180 μ HV. Bath gold concentration is 8.0...12.0 g/l, cathode current density 0.5...1.5 A/dm², pH 3.5...4.5, temperature 293...333 K. The IMPEX-ZN bath has been developed specially for electronic industry applications for the gold plating of housings and seal wires. This bath is used to obtain gold coatings of any thickness, containing 99.99 Au and free from pores, flexible and readily solderable. High tightness of the gold coatings coupled with their small thickness makes possible their application as decorative coatings outside buildings. The IMPEX-ZN bath has been used, among other things, for the gold plating of both the interior and exterior of the Royal Castle in Warsaw. Concentration of gold in that bath ranges between 8.0...12.0 g/l, cathode current density 0.3...1.2 A/dm², pH 6.0...7.0, temperature 328...343 K. The IMPEX-ZNS bath is used for the gold plating of openwork for transistors and integrated circuits. Gold content of the latter bath is 99.99% Au. The coating is applied by spraying the openwork surface under pressure with hot electrolyte via platinum nozzles. The IMPEX-ZNS bath is outstanding for its high deposition rate (thanks to its being mixed vigorously) and considerable reduction of gold consumption. All the technologies presented here have been applied successfully in Polish industry.

A NUMERICALLY CONTROLLED TURNING AND BORING LATHE

The DEFUM Machine Tool Factory, Dąbrowa Górnicza, has started the production of a new type of single-column numerically controlled KNB 110/135 NC turning and boring lathes equipped with the Polish NUMS 322 control system. These machine tools are used for the multi-operational working of objects made of cast iron and steel.

The rotational speed of the table face plate is controlled by means of an automatic electrohydraulic system making possible the selection of optimum machining conditions for a given operation. The top slide of this lathe has been

fitted with a turret having five tool mountings. That turret is also controlled automatically, which facilitates the program-controlled selection of the tool suitable for a given operation.

The feed assemblies are provided with independent drives incorporating variable-speed D.C. motors which in turn makes possible the application of optimum values of working feeds and fast travel of the top slide both in horizontal and vertical directions.

The KNB 110/135 NC machine tool body is of a very rigid design ensuring the attainment of a high degree of machining accuracy during operation involving the utilization of full power of the motor driving the table face plate.

Technical data: table diameter 1100 mm, maximum turning diameter 1350 mm, maximum height of the workpiece 950 mm (optional 1300 mm), table rotational speed 8...250 r.p.m., table face plate driving motor rating 30 kW, infinitely variable slide feed (horizontal and vertical) 3...500 mm/min, vertical and horizontal slide travel 800 mm, machine tool weight 11 tons.

A BITUMINOUS ANTI-CORROSIVE PREPARATION FOR THE MINING INDUSTRY

The Technical University of Gdańsk, in cooperation with the Institute of Fine Mechanics, Warsaw, have developed the technology of manufacturing a new bituminous anti-corrosive preparation designed for use chiefly in the mining industry. This preparation protects against corrosion the steel structures and installations buried underground or those immersed in water or working in conditions of very high moisture content.

The preparation comes in the form of a black tixotropic mass. Its main constituents comprise bituminous substances, waxes, and hydrocarbon compounds with the addition of a corrosion inhibitor UNIKOR-60 (developed by the Technical University of Gdańsk and the Institute of Fine Mechanics), fillers, water repellents, penetrating substances and an organic solvent. It may be applied on wet and purified surfaces. Its tixotropic properties make possible its application by brush onto a vertical surface. The thickness of the layer applied is higher than 100 μ m. Temperature of dry coating dripping from a vertical surface (coating thickness of 200 μ m) exceeds 360 K. Tests have shown that the protective properties of this preparation applied on carbon steel

placed in an NaCl corrosion chamber are such that coatings with a thickness higher than 200 μm show first signs of corrosion after more than 1000 hours. Physico-chemical properties of the preparation: ignition temperature 290 K, apparent viscosity determined by the „Rheotest“ 2 rotation viscometer at 293 K 45.0 mPa·s, drying time 24 hrs.

A MULTI-ZONE VACUUM FURNACE WITH A COLD CHAMBER

The LAMINA Electronic Works, Piaseczno, has developed the construction of the TG22A multi-zone furnace with a cold chamber. The TG22A furnace ensures the generation of a uniform temperature field during the heating and annealing of the charge, and also lends itself for the application of high-vacuum technology of soldering silicon semi-conducting components. The interior of the heating chamber of the furnace has the shape of a cube whose side is 410 mm long. Pressure inside that chamber and the water cooled cooling system are controlled automatically. The heating elements placed on the walls of the heating chamber form three heating zones. The heating elements are connected in a star arrangement. The heating ducts are in the form of heating coils, each coil consisting of four molybdenum wires with a diameter of 2 mm. Thermal insulation is constituted by metal screens. Each wall of the chamber has four screens spaced 4 mm from one another. Screens of each wall are fastened together to form six identical cascades which can be assembled and disassembled independently from each other. The charge rests on cylindrical, molybdenum supports situated in the bottom part of the supporting jacket which constitutes the furnace body.

The furnace is equipped with a vacuum generating station ensuring a pumping of 700 l/s and a final pressure of 133×10^{-6} Pa, a power supply unit with a maximum power rating of 10 kV·A in each circuit, and a control unit ensuring automatic realization of the heating cycle.

Technical data of the furnace: rated operating temperature 1375 K, temperature field non-uniformity $\leq 1\%$, working space dimensions 0.3 x 0.3 x 0.3, permissible charge weight 60 kgs, furnace dimensions 3.5 x 1.9 x 1 m, weight 800 kgs approx.

COMPENSATION OF TEMPERATURE DRIFT IN D.C. MEASURING AMPLIFIERS

The Institute of Physics, Polish Academy of Sciences, Warsaw, has developed a method of compensating the temperature drift in direct current measuring amplifiers (Polish Patent No 123531) used in equipment in which it is necessary to amplify a low voltage signal. The basic advantage of that method lies in the possibility of hooking up a highly sensitive measuring amplifier while using output components of average quality. The amplifier design may be moreover simplified by eliminating the compensating components generally hooked up to operational amplifiers. The principle of this method consists in the connection of a test resistor between the supply voltage and, successively, to both terminals of the output stage. These terminals compensate the unbalanced, input voltage. This makes it possible to determine at which terminal there occurs an increase or decrease (in an algebraic sense) of the temperature drift of the operational amplifier. In the next step a resistor whose resistance is selected experimentally in such a way that the temperature drift of the unbalanced input voltage of the operational amplifier is connected between the supply voltage and one terminal of the operational amplifier. In case of a positive temperature drift value, that resistor is connected to the terminal corresponding to drift reduction, while in the case of a negative temperature drift value, the resistor is hooked up to the terminal corresponding to the increase of the drift.

This method has been applied, among other things, for the construction of an amplifier used in temperature controllers.

A RADIATION-CONVECTION DRYER

The SP-400 radiation-convection dryer, built at the Institute of Telecommunication and Radio Engineering, Warsaw, is designed for drying and hardening organic coatings on printed circuit boards. It may be also used for the encapsulation of electronic components, hardening of inscriptions, drying of pastes on hybrid circuits etc.

The SP-400 dryer incorporates halogen-containing quartz/tungsten radiators

outstanding for the high temperature of their filament (2400 K approx.) and its short-wave radiation spectrum (about 85 % of the spectrum is in the wavelength range of 0.76...2 μm). As a result, the heat radiation penetrates the whole volume of a coating and the entire depth of a laminate. These radiators moreover ensure the possibility of attaining a high density of radiation intensity (about 30 kW/m²) required for the rapid hardening of coatings on printed circuit boards and very short start up times (several minutes).

The printed circuit boards are transported by a net-type conveyor powered by a precision drive system with an infinitely variable speed control arrangement ensuring a high stability of conveyor travel rate (travel rate inaccuracy < 1%). The ventilation system, besides its basic function which consists in the removal of volatile constituents evolved from the coatings hardening agent, also produces warm air flow by convection, so that the PCBs being worked are heated up. After hardening, the PCBs are dried rapidly by an air cooling assembly with an output of about 800 m³/h. Technical data: maximum installed power 16.5 kW, maximum PCB width 400 mm, conveyor speed 0...3 m/min, power supply 3 x 380 V, 50 Hz, dimensions 2200 x 1140 x 800 mm.

CSO: 2020/229

POLAND

REFRACTORY PROPERTIES OF BETA-ALUMINA CERAMICS IN MOLTEN SODIUM

Warsaw SZKLO I CERAMIKA in English No 2, 1985 pp 41-43

[Article by Grzegorz Rog, Institute of Materials Engineering, Academy of Mining and Metallurgy, Krakow: "Reactivity of Beta-Alumina Ceramics in the Medium of Molten Sodium"]

[Text] [Abstract] On the basis of the free enthalpy of formation of both β and β'' -alumina, determined by the solid-state galvanic cell method, the thermodynamics of selected reactions with molten sodium was discussed. It was shown that the degradation processes usually occurring during a long-time contact of the β -alumina ceramics with molten sodium cannot be caused by chemical reactions.

Introduction

β -alumina is a general term that refers to a family of non-stoichiometric compounds of soda and alumina, $\text{Na}_2\text{O} \cdot x\text{Al}_2\text{O}_3$, where X falls in the range 5-11. There are two β -aluminas, termed β - Al_2O_3 and β'' - Al_2O_3 , the compositions of which in a limiting cases are $\text{NaAl}_{11}\text{O}_{17}$, NaAl_5O_8 respectively.¹ Their crystal structures are known to be layered, consisting of blocks of the spinel structure separated by loosely packed layers containing the sodium and oxygen ions. In the spinel blocks there are four layers of oxygen ions, cubic close-packed with aluminum ions occupying all the sites normally filled by both aluminum and magnesium ions in the spinel MgAl_2O_4 . The composition of the single β -alumina phase depends on the number and arrangement of the sodium and oxygen ions in the layers. The principal difference between the β and β'' structures is in the stacking sequence of the spinel blocks. The packing of the sodium ions is highly defective. That is the reason for the high ionic conductivity of β -aluminas. On account of it β -aluminas are ones of the most interesting materials for the technology of high-energy density battery systems. They serve there as ionic membranes.²

The knowledge of the reactivity of β -aluminas with molten sodium is of importance for their use in sodium-sulphur batteries. The β -alumina membranes are there in a constant with a corrosive medium of molten sodium. In order to estimate the reactivity of β -aluminas the consistent thermodynamic data are necessary. Literature data on thermodynamic properties of β -aluminas are

fragmentary and often contradictory.³⁻⁷ In the present work the free enthalpy of formation of both β - and β'' -alumina was determined. Then, the thermodynamics of selected reactions with molten sodium was discussed. The solid-state galvanic cell method was applied.⁸ The two following galvanic cells were built:

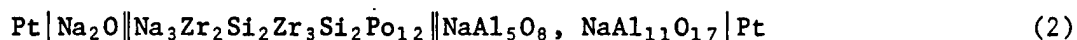
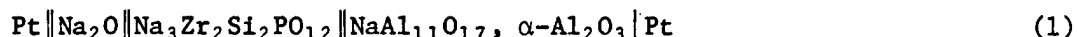

Sodium zirconium silico-phosphate, $\text{Na}_3\text{Zr}_2\text{Si}_2\text{PO}_{12}$, served as an auxiliary electrolyte. This compound, termed Nasicon, is one of the best fast sodium ions conductor. The left half-cell in both the cells included soda particles, dispersed in the Nasicon phase, so that Na_2O -activity could be assumed as equal to unity. The Na_2O -activity at the right half-cell was fixed by the two phase equilibrium of ($\beta\text{-Al}_2\text{O}_3 + \alpha\text{-Al}_2\text{O}_3$) or ($\beta''\text{-Al}_2\text{O}_3 + \beta\text{-Al}_2\text{O}_3$). The electromotive force (EMF) is a result of a difference in chemical potentials of Na_2O in both half-cells and it related to the free enthalpy change due to the chemical reactions which occur upon a virtual current flow across the cell.

Experimental

All the materials used were of reagent-grade purity. The samples of Nasicon were prepared in the following way: The mixture of Na_2CO_3 , ZrO_2 , $\text{NH}_4\text{H}_2\text{PO}_4$ and SiO_2 was calcined in two steps, at 570 K for 10 hr, and at 1370 K for 6 h. Then the mixture was milled. After adding ethylene glycol and drying, the powder was pressed into cylinders. A pressure of 600 MPa was applied. The green ceramic samples were sintered in a platinum crucible in air at 1500 K for 48 h. From the cylinders the pellets of 2 mm thick and 10 mm in diameter were cut and applied as electrolyte in the cells (1) and (2). The left half-cells were obtained the following way: The appropriate amount of powder of Nasicon was impregnated by a saturated aqueous solution of sodium carbonate. The powder was dried and calcined, preliminary at 470 K overnight, and at 1170 K for 4 h. Then it was milled and pressed into pellets. The x-ray analysis of the pellets indicated that a pure Na_2O -phase was present in the Nasicon-phase. The right half-cell pellet consisted of the mixture of $\beta\text{-Al}_2\text{O}_3$ and $\alpha\text{-Al}_2\text{O}_3$ in the cell (1), and of $\beta''\text{-Al}_2\text{O}_3$ and $\beta\text{-Al}_2\text{O}_3$ in the cell (2). Both two-phase mixtures were obtained by heating the appropriate amounts of $\alpha\text{-Al}_2\text{O}_3$ and Na_2CO_3 powders at 1370 K for 5 h. Each mixture was then pelletized and sintered in air at 1850 K for 3 h. The phase composition of each half-cell was then controlled by x-ray analysis. All half-cell pellets were of 2 mm thick and 10 mm in diameter.

The half-cell and electrolyte pellets were assembled in a simple spring-loaded alumina holder, according to the respective cell arrangement. Electrical contacts were made via a platinum wires connected with the platinized outer surfaces half-cell pellets. The cell was placed in the electrical resistance furnace and heated up to the measurement temperature. The EMF values were monitored with a digital voltmeter (Unitra 1321, internal resistance $10^{10}\Omega$). Five independent series of EMF measurements were performed in

the temperature range 970-1220 K/cell (1), and 780-1190 K/cell (2), respectively.

Results and Discussion

The overall-cell reactions which take place in the cells under study can be written as follows

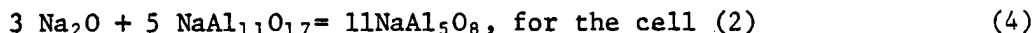
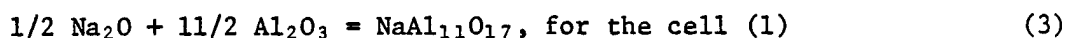

One electron in half-cell reactions in cell (1), and six electrons in cell (2) are exchanged. Thus, the EMF of the cell (1), E_I is related to the standard molar free enthalpy of β -alumina formation (from oxides), $\Delta G^\circ_f(\beta)$

$$\Delta G^\circ_f(\beta) = -FE_I \quad (5)$$

(F is the Faraday constant). However, the EMF of the cell (2), E_{II} is related to the standard free enthalpy change, ΔG°_r , accompanying the reaction given by equation (4)

$$\Delta G^\circ_r = -6 FE_{II} \quad (6)$$

Thus, the equation (5) renders possible to calculate the standard molar free enthalpy of β -alumina formation directly from the EMF values. However, the standard molar free enthalpy of β'' -alumina formation (from oxides), $\Delta G^\circ_f(\beta'')$, can be obtained from equations (3)-(6) using the principle of constant heat summation (Hess's law):

$$\Delta G^\circ_f(\beta'') = -F(E_I + E_{II}) \quad (7)$$

The EMF of both measured cells were observed to change linearly with the temperature

$$E_I = 1570 - 0.31 T, \pm 10 \text{ mV} \quad (8)$$

$$E_{II} = 52.9 - 0.029 T, \pm 1 \text{ mV} \quad (9)$$

The $\Delta G^\circ_f(\beta)$, $\Delta G^\circ_f(\beta'')$ and ΔG°_r were calculated substituting for E_I and E_{II} from equations (5)-(7)

$$\Delta G^\circ_f(\beta) = -151.48 + 0.0299 T, \pm 1.50 \text{ kJ} \quad (10)$$

$$\Delta G^\circ_f(\beta'') = -71.64 + 0.0151 T, \pm 0.67 \text{ kJ} \quad (11)$$

$$\Delta G^\circ_r = -30.62 + 0.0167 T, \pm 0.58 \text{ kJ} \quad (12)$$

The reactivity of β - and β'' -alumina with molten sodium was estimated by considering the following reactions

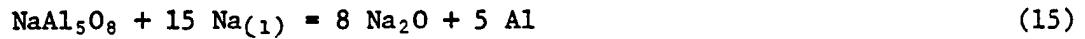
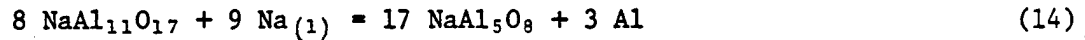
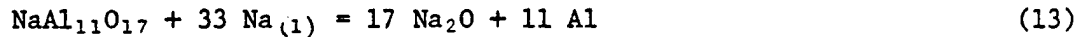

(Na₍₁₎ denotes here liquid sodium). The free enthalpy changes, related to the reactions result from Hess's law

$$\Delta G^\circ_{13} = 17/2 \Delta G^\circ_f(\text{Na}_2\text{O}) - 11/2 \Delta G^\circ_f(\text{Al}_2\text{O}_3) - \Delta G^\circ_f(\beta) \quad (16)$$

$$\Delta G^\circ_{14} = 9/2 \Delta G^\circ_f(\text{Na}_2\text{O}) - 3/2 \Delta G^\circ_f(\text{Al}_2\text{O}_3) + 17 \Delta G^\circ_f(\beta'') - 8 \Delta G^\circ_f(\beta) \quad (17)$$

$$\Delta G^\circ_{15} = 15/2 \Delta G^\circ_f(\text{Na}_2\text{O}) - 5/2 \Delta G^\circ_f(\text{Al}_2\text{O}_3) - \Delta G^\circ_f(\beta'') \quad (18)$$

$\Delta G^\circ_f(\text{Na}_2\text{O})$, $\Delta G^\circ_f(\text{Al}_2\text{O}_3)$ are the standard free enthalpy of formation of respective oxide from metal and oxygen, and can be found in literature. According to data being calculated from Reference [10]

$$\Delta G^\circ_f(\text{Na}_2\text{O}) = - 396.2 - 0.134 T, \text{ kJ} \quad (19)$$

$$\Delta G^\circ_f(\text{Al}_2\text{O}_3) = - 1636.6 - 0.143 T, \text{ kJ} \quad (20)$$

Introducing equations (19) and (20) to (16)-(18) we obtain

$$\Delta G^\circ_{13} = 5785 - 0.382 T, \text{ kJ} \quad (21)$$

$$\Delta G^\circ_{14} = 666 - 0.363 T, \text{ kJ} \quad (22)$$

$$\Delta G^\circ_{15} = 1192 - 0.663 T, \text{ kJ} \quad (23)$$

For β -alumina to be resistant to attack by molten sodium, ΔG°_{13} and ΔG°_{14} , must be positive; so ΔG°_{15} does for β'' -alumina. From the phase diagram, worked out by le Cars et al. β -alumina is known to be stable up to about 2270 K, and β'' -alumina up to about 1820 K. Furthermore, metallic sodium becomes gaseous at 1156 K [10]. ΔG°_{13} , ΔG°_{14} , ΔG°_{15} result from equations (21)-(23) to be positive in the whole temperature range up to the boiling point of metallic sodium. Thus, the important conclusion may be drawn: The changes, usually observed during a long-time contact of the β -alumina ceramics with molten sodium-sulphur batteries, cannot be caused by chemical reactions.

Acknowledgements

The author gratefully acknowledges financial support to the Research Project No 30.10 (Polish Academy of Sciences).

REFERENCES

1. They, J. and Briancon, D., REV. HAUTES TEMPER. REFRACT, Vol 1, 1964 p 221.
2. Weber, N., and Kummer, J.T., 21st Annual Power Sources, 1967 p 37.
3. Kummer, J.T., PROG. SOLID STATE CHEM., Vol 7, 1972 p 141.
4. Choudhury, N.S., J. ELECTROCHEM. SOC., Vol 120, 1973 p 1663.
5. Fray, D.J., Metall. Trans., 8B, 1977 p 153.
6. Elrefaie, P.A. and Smeltzer, W.W., J. ELECTROCHEM. SOC., Vol 128, 1981 p 1443.
7. Dubreuil, A., Malefant, M. and Pelton, A.D., J. ELECTROCHEM. SOC., Vol 128, 1981 p 1443.
8. Kiukkola, K. and Wagner, C., J. ELECTROCHEM. SOC., Vol 104, 1957 p 308.
9. Hong, H.Y.P., Kafalas, J.A. and Bayard, M.L., MAT. RES. BULL., Vol 13, 1978 p 757.
10. Barin, I. and Knacke, O., "Thermochemical Properties of Inorganic Substances," Ed. O. Kubashevski, Springer Verlag 1973.
11. Le Cars, Y., They, J., and Collongues, R., C.R. ACAD. SCI., Paris, Series C274, 1972 p 3.

CSO: 2020/227

END