

050063

JPRS-ESA-85-035

22 November 1985

# East Europe Report

SCIENCE AND TECHNOLOGY

19981022 087

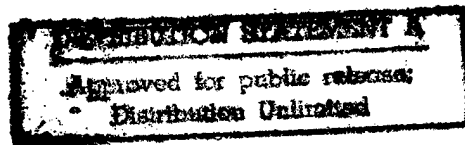

DTIC QUALITY INSPECTED 4

**FBIS**

FOREIGN BROADCAST INFORMATION SERVICE

REPRODUCED BY  
NATIONAL TECHNICAL  
INFORMATION SERVICE  
U.S. DEPARTMENT OF COMMERCE  
SPRINGFIELD, VA. 22161

58  
AD4

#### NOTE

JPRS publications contain information primarily from foreign newspapers, periodicals and books, but also from news agency transmissions and broadcasts. Materials from foreign-language sources are translated; those from English-language sources are transcribed or reprinted, with the original phrasing and other characteristics retained.

Headlines, editorial reports, and material enclosed in brackets [ ] are supplied by JPRS. Processing indicators such as [Text] or [Excerpt] in the first line of each item, or following the last line of a brief, indicate how the original information was processed. Where no processing indicator is given, the information was summarized or extracted.

Unfamiliar names rendered phonetically or transliterated are enclosed in parentheses. Words or names preceded by a question mark and enclosed in parentheses were not clear in the original but have been supplied as appropriate in context. Other unattributed parenthetical notes within the body of an item originate with the source. Times within items are as given by source.

The contents of this publication in no way represent the policies, views or attitudes of the U.S. Government.

#### PROCUREMENT OF PUBLICATIONS

JPRS publications may be ordered from the National Technical Information Service, Springfield, Virginia 22161. In ordering, it is recommended that the JPRS number, title, date and author, if applicable, of publication be cited.

Current JPRS publications are announced in Government Reports Announcements issued semi-monthly by the National Technical Information Service, and are listed in the Monthly Catalog of U.S. Government Publications issued by the Superintendent of Documents, U.S. Government Printing Office, Washington, D.C. 20402.

Correspondence pertaining to matters other than procurement may be addressed to Joint Publications Research Service, 1000 North Glebe Road, Arlington, Virginia 22201.

22 November 1985

# EAST EUROPE REPORT SCIENCE AND TECHNOLOGY

## CONTENTS

### BULGARIA

Bulgarian Academy of Sciences: 1984 Achievements, Future Tasks (SPISANIE NA BULGARSKATA AKADEMIYA NA NAUKITE, No 4, 1985).....	1
Statement on 1984 Report, by Blagovest Sendov	1
Discussion of Report	7
1985 Pledge of Academy of Sciences	27
Concluding Speech of Academician Balevski, by Angel Balevski	30
Prospecting for New Mineral Deposits Encouraged (Ivan Kostov; SPISANIE NA BULGARSKATA AKADEMIYA NA NAUKITE, No 4, 1985).....	35

### CZECHOSLOVAKIA

CSSR JSEP Computer EC 1027 Described (Zdenek Korvas; MECHANIZACE AUTOMATIZACE ADMINISTRATIVY, No 3, 1985).....	40
SMEP in Mass Data Processing Discussed (Jana Folprechtova, et. al.; MECHANIZACE AUTOMATIZACE ADMINISTRATIVY, No 3, 1985).....	46

BULGARIA

**BULGARIAN ACADEMY OF SCIENCES: 1984 ACHIEVEMENTS, FUTURE TASKS**

**Statement on 1984 Report**

Sofia SPISANIE NA BULGARSKATA AKADEMIYA NA NAUKITE in Bulgarian No 4, 1985  
pp 5-10

[Statement by Academician Blagovest Sendov on the Accountability Report of the Bulgarian Academy of Sciences on Its 1984 Activities; the materials published herein, with a certain abridgement, were presented at a report session of the General Assembly of the Bulgarian Academy of Sciences held on 10 April 1985]

[Text] The Bulgarian Academy of Sciences [BAN] is presently celebrating its 115th anniversary, loyal to the legacy of assisting the spiritual development and material enrichment of the Bulgarian people. Very noteworthy events have occurred in the life of our academy during these 115 years and they have shaped its appearance and content. The importance and role of each of these events have been determined by the degree of its consequences. For this reason it is only for history to judge and assess them.

It is natural for us to start with the last event in the life of our nation and which is indisputably of exceptional importance for the further development of the BAN and of science generally in Bulgaria. This was the February Plenum of the BCP Central Committee of this year. In the report, the introductory speech and concluding speech of Comrade T. Zhivkov at this plenum, assessments and formulations were found which are a joy to all scientists in our country. At the same time these documents establish the need for a new approach in scientific development and the application of scientific results for technical progress in Bulgaria. These oblige all our scientific community and specifically the BAN to look critically at their present activities and significantly reorganize their work in the future.

Let us recall the first law which was formulated by Comrade T. Zhivkov in his introductory speech at the February Plenum: "The scientific and technical revolution is developing both under socialism and under capitalism. But precisely socialism is the social system which creates conditions for its flourishing as an objective pattern in the interest of society and of man."

In order for this law to be manifested, of crucial significance are the development and strengthening of the forms for organizing scientific research

which are typical and specific of socialism. But it is well-known that the socialist type academies of sciences are a typical and specific form for organizing scientific research in the socialist countries. The world's strongest scientific organization, the USSR Academy of Sciences, serves as a model for this type of academy. It is a new type of academy inherent only to the socialist countries and is not a copy of anything created under capitalism. In turn, the academies of sciences in the socialist countries, due to their uniform principles of organization, are united in close and effective collaboration and this turns them into the scientific forefront in the socialist community. It is that scientific front which is of crucial significance for the manifesting of the first law about which Comrade T. Zhivkov spoke. For this reason the reorganization of our work in carrying out the decisions of the February Plenum must lead to a further strengthening of the BAN and to a reinforcing of its role as the largest, most comprehensive and most prestigious scientific organization in our country.

The report on the activities of the BAN in 1984 has been distributed ahead of time after its discussion in the Presidium. Everyone present has had an opportunity to become acquainted with its contents and these largely consist of the texts discussed and approved in reporting on the activities of the academy's individual units in 1984. Along with this a number of quantitative characteristics and other data have been given.

Our present task is not merely to report on the fulfillment of last year's plan but rather to assess the work accomplished by us from the viewpoint of the decisions of the February Plenum of the BCP Central Committee. This will give us an opportunity to better see the problems which confront us now in carrying out the decisions of this plenum.

The most important results from the activities of the unified centers and independent scientific elements in the BAN and the Sofia Kliment Okhridski University in carrying out the National Comprehensive Program "Fundamental Research" have been given in the report. An analysis of these results indicates that their spectrum is comparatively broad and their character is diverse. We will not even enumerate the most significant results for a whole number of the unified centers. We will merely take up certain typical examples which illustrate the nature of our work.

It is important to point out that the BAN and the Sofia Kliment Okhridski University in 1984 enriched science with newly discovered facts and patterns in abstract objects, in nature and in society. Let me give several examples from different scientific areas.

Compact spaces have been described in which virtually all optimization problems have a uniform solution; it has been established that the centers of a latent image in the primary photographic process do not influence each other both in their formation during the exposure time as well as during the growth of the development process; the complete and secondary structure of ribosomal RNA has been determined; it has been established that avian leukosis viruses cause tumors in the mucous membrane of the small intestine; the integrated social make-up and degree of social development in individual social groups,

of modern Bulgarian society and their basic strata and of the differences and contradictions between their needs and interests have been brought out.

Obviously, the mentioned and many other results of this nature contained in the report are fundamental scientific results. It is natural for us to immediately pose the question of using these fundamental results for applied research and introduction into social practice and production. In many instances the further links in the chain are apparent but this is not always the case. This is due not only to poor organization but also to objective factors. Simply the link between a fundamental result and application usually is constructed from many elements. An application is founded on numerous and diverse fundamental results while a fundamental result causes numerous and diverse applications.

Last year the leadership of the BAN worked out a proposal to set up specialized design production bases to ensure a greater percentage of fundamental results with the possibility of more rapid and more diverse application. We must have confidence that these proposals of the academy will be achieved in carrying out the decisions of the February Plenum.

Let us now examine the results described in the report from a different viewpoint.

The modeling method is a widely employed one for discovering new facts and patterns. It is the main technique in much of the research reflected in our report. Here are several examples:

New models have been created for quasidynamic or dynamic processes in plastically deforming bodies; a numerical model has been created for a unidimensional crystal on a heterogeneous base which shows the effect of so-called resonance mobility; a model has been created for the development of the Rosenskiy paleovolcano in the Sredna Gora Mountains; a spatial model has been constructed of the charge field of the enzyme lysozyme; a theoretical model has been constructed for the labor behavior of the Bulgarian people viewed as a social phenomenon in which position in life and aspirations of the individual play an important role; a National Model of the Food Complex in Bulgaria has been created and this is to be a part of a series of analogous models for other socialist countries.

One gains the impression of the great diversity of algorithms and corresponding programs created at the BAN, for example, new numerical models and algorithms have been created for solving the problems of linear algebra, mathematical physics as well as integer and non-linear optimization; algorithms and program packets have been developed for solving an entire range of problems in designing, managing and analyzing multirelated systems; algorithms and program products have been developed for structural and parametric analysis of control systems with increased intelligence, for computer graphics and the processing of operational information.

This list could be continued and encompass many different unified centers and institutes. All these results make a contribution and are of importance, but if viewed from the standpoint of the February Plenum, something else must also

impress us. Modeling, algorithmizing and program implementation can be viewed as integral technologies of scientific research. But in practice up to now they have had an emphatic "sectorial" nature according to the individual areas of science. The conversion of these technologies into truly integral ones will substantially increase the quality and results of the scientific research. The solution to this problem must be sought in realizing a higher level of information both within the academy itself as well as better ties between the individual collectives using the same technology in different areas. This question will be of important significance with the new organization of scientific activities through special-program collectives.

Now let us take up another aspect of the report. A significant portion of the obtained scientific results in the BAN and Sofia University last year was addressed to the Bulgarian people and the Bulgarian state and have a national character. Here we will mention just several characteristic examples.

New anthropological data have been obtained on elucidating the ethnogenesis of the Bulgarian people in the Rhodopia region; the basic parameters and trends in the development of the socioclass structure of modern Bulgarian society have been examined; the most essential problems of political economy and the socioeconomic development of Bulgaria have been examined; the social status of working women under the conditions of the developed socialist society in Bulgaria has been investigated and an analysis made of the state and measurements of the Bulgarian family under socialist conditions; the main stages and trends in the development of the Bulgarian legal system have been investigated; published or prepared for publishing are the "Rechnik na bulgarskiya ezik" [Dictionary of the Bulgarian Language], Vol 4, "Etimologichen rechnik na bulgarskiya ezik" [Etymological Dictionary of the Bulgarian Language], Vols XXIII and XXIV, "Kirilo-Metodieva entsiklopediya" [The Cyril and Methodius Encyclopedia], Vol I; completed is Vol VII "Osvobozhdeniye i razvitie na Bulgariya do 1903 g." [The Liberation and Development of Bulgaria Up to 1903] of the 14-volume "Istoriya na Bulgariya" [The History of Bulgaria]; a number of monographs has been published on Bulgarian history, on the history of Bulgarian art and so forth.

All these results are an important contribution of the BAN and Sofia University with a strong social effect. In this area our work must be improved, broadened and deepened because Bulgaristic research can develop in our nation and abroad only with a strong Bulgarian root.

In the context of this group of predominantly humanitarian research, we must state yet again the significant lag in technical support. Labor productivity will be greatly increased and quality improved in the compiling of dictionaries and the editing of multivolume publications if modern equipment for data processing and duplicating equipment are introduced. This is again a question of technology which was at the center of attention of the February Plenum.

The accountability report of the BAN concerning 1984 activities provides the most important results also in its applied scientific activities. These have been grouped according to strategic areas such as new materials, automation, electronization, biotechnology, power and results with a social, health and

ecological effect. It must be emphasized that the BAN has established the start of a new subsector in machine building and electronics with the development of the Bulgarian Pravets-82 and Pravets-83 personal computers.

The BAN is involved within the Coordination Council of the Academies of Sciences of the Socialist Countries on Computer Equipment and Informatics in developing a concept for new generations of computer equipment and its scientific support.

The activities of the BAN in scientific instrument building has been taken up as a separate point. What has been done in this area is substantial but far from satisfactory. The serious lag in the development of production facilities jeopardizes the fulfillment of the production program. In light of the decisions of the February Plenum, this is a very critical moment since scientific instrument building to a large degree determines the level of technologies for scientific research.

The BAN activities have been significant in the regional programs for Blagoevgrad, Burgas, Sofia, Varna, Plovdiv, Pleven, Rhodopia, Razgrad and Strandzha -- Sakar. All these programs are being discussed and considered separately and their effect is significant for the appropriate regions. But the increase in the number of regional programs and the stated desire of other okrugs to conclude new regional programs have required a review of academy policy toward these programs during the next 5-year plan. Probably the overall concept for the program organization and the program collectives will help us find a better solution.

The efforts of the leading bodies of the BAN in 1984 were focused on improving the forms and methods of management. In carrying out the decisions of the National Party Conference on Quality, under the leadership of the BAN Presidium and together with the party and other public organizations, a review was made and an integrated program adopted for improving the quality of work in the academy. At joint sessions with the party committee the Academy Union Committee and the Komsomol Committee, results were discussed from checks on the fulfillment of tasks stemming from the decisions of the National Party Conference, the state of public health, the fulfillment of the Youth Work Program and so forth.

As a rule, each session of the BAN Presidium discusses one or two major problems of the academy's scientific policy. These problems after discussion are usually incorporated in the appropriate problem or coordinating councils under the Presidium.

The activities of the BAN leadership bodies are closely tied with the Ideological Policy Section of the BCP Central Committee, with the BCP City Committee and Leninskiy Rayon Committee which have always shown understanding for our problems and have provided the required help.

The report gives detailed information on the state of personnel in the BAN. Here we will only mention the elections held in 1984 which elected 9 new academicians and 27 corresponding members. At present the BAN has 52 academicians and 80 corresponding members.

The BAN report on 1984 activities provides information and analyzes the international activities of the academy which are significant. Our international activities with the Soviet Union are the most extensive and beneficial. Of the total nearly 4,000 scientists sent abroad in 1984 on official trips, around 1,500 went to the USSR and the same number to all the remaining socialist countries. From a review of the results from the joint developments and the fulfillment of the bilateral and multilateral plans and measures, it can be seen that the effect from the international activities of the BAN is of substantial significance for the development of science in our country. However, it cannot be said that in this regard we have achieved the optimum, particularly taking into account the tasks which have been posed by the February Plenum for maximum up-to-date information and the rapid transfer and utilization of achievements in world science. For improving the effect from the international activities of the BAN, decisive measures are needed in organizational and resource terms. Good organization of international activities involves not only the scientific effect but also is of importance for the international prestige of our science and the Bulgarian state.

The BAN and Sofia University have successfully completed the tasks of the 1984 Scientific Research Plan. The academy's promise to realize an economic effect and contribution has been carried out. Of the promised 520 million leva over the 5-year plan, some 476 million leva have already been realized. This is actually a gain of several-fold in comparison with the previous 5-year plans. As was honestly said recently by our chairman, Academician Angel Balevski, this cannot be our primary concern during the following 5-year plan. The BAN and Sofia University must work for significant fundamental results which will be multiplied in industry, agriculture and social practice.

At present, we are confronted with the carrying out of new and responsible tasks which stem from the decisions of the remarkable February Plenum. We must restructure the scientific front and incorporate new approaches in the organization of our scientific research, establish special-program collectives and strengthen the social [volunteer] principle in the management of science. The BAN must be in the forefront of the scientific and technical revolution in our country. For this reason it itself must revise its activities in accord with the new tasks and demands. It is essential to improve planning techniques for scientific development in accord with the new strategy. We must also update certain of the organizational principles for scientific research activity. Our tenacity and concern for establishing the proper physical plant must be increased many-fold.

Highly skilled personnel and scientific schools are decisive for the development of society. The program-based organization of science will require high scientific, organizational and human qualities from the leaders of the special-program collectives. For this reason the BAN must make a constant effort for the scientific growth of the personnel.

In 1985, the large collective of the BAN must successfully fulfill the plan for the Eighth 5-Year Plan, overfulfill its promise for an economic contribution and economic effect, accelerate the introduction of scientific results into practice and raise the level of Bulgarian science. The posed tasks are within the capabilities of our collective and the leadership of the

BAN is confident that they will be carried out in honor of the Eighth BCP Congress.

#### Discussion of Report

Sofia SPISANIE NA BULGARSKATA AKADEMIYA NA NAUKITE in Bulgarian No 4, 1985  
pp 10-28

[Statements by academy members on the 1984 BAN report]

[Text] **Academician Milko Borisov:** It can be considered that the beginning to the development of physical sciences in the BAN was made precisely 40 years ago, after 14 January 1945. Georgi Nadzhakov was elected a regular member of the BAN. From the General Physics Institute Under the BAN established by him there have gradually arisen the units of today's Unified Physics Center as well as certain other BAN institutes which are outside the Unified Physics Center.

At present, in the 10 independent units of the Unified Physics Center there are around 1,800 persons employed of which one-third are scientific workers. In 1984, specialists from the center published 844 scientific articles in foreign and Bulgarian publications, they gave 350 scientific reports, 60 monographs and monographic collections were printed, and 405 quotations were spotted abroad from their earlier works. Some 52 inventions were recognized, and 230 exhibits were shown at 14 fairs and which received recognition.

The center's state budget amounts to 6,904,000 leva, with income received of 580,000 leva under extraplan contracts and an economic effect valued at 12 million leva was realized. In spite of these quantitative results from the activities of the units of the Unified Physics Center, in adding a certain quality evaluation, it can be said that labor productivity and effectiveness from the activities of the scientific workers in our area of physical sciences as well as generally in other sciences still remains very low in comparison with the most developed countries. The results obtained from the activities of the units in the unified center during the current year are also not sufficient from the viewpoint of the high demands which have been posed for our science by the February Plenum of the BCP Central Committee.

I would like to voice only certain of the considerations on three questions related both to the activities of the units in the Unified Physics Center during the previous year as well as concerning the future, questions which also apply to the BAN generally. These are scientific instrument building, optical electronics and laser equipment and the new posing of fundamental research in the report of Comrade Todor Zhivkov.

First, it can be said that scientific instrument building represents the most strategic area of modern scientific-technical progress. In the broad sense of the word it encompasses equipment for automation, various metering devices and a number of modern structural elements and materials for them. The very first meeting of representatives from the academies of the socialist countries recognized collaboration in the area of scientific instrument building between

the socialist countries as exceptionally important. This plays a major role also in the antiembargo policy of our countries. Scientific instrument building is the chief factor for solving the problem posed by the February Plenum of the BCP Central Committee concerning standardization and creating a modular principle for modern technologies.

The past year was very important for making a start to the development of scientific instrument building in the units of the Unified Physics Center and generally in the BAN. Our center produced scientific instruments for direct sale valued at 6.67 million leva. Of these exported abroad were instruments valued at 5.16 million leva, chiefly 51 TsLAM-270 systems for automating scientific research and production processes for units of the USSR Academy of Sciences.

These figures, like the general figures for scientific instrument building in the BAN, from which a total product for the academy valued at 11,967,000 leva has been sold, of which 6,209,000 leva were foreign exchange leva, are far from characterizing the state and capabilities of instrument building in the BAN presently. They are limited (chiefly these figures) by the presently very limited production capabilities of the BAN, as was also pointed out in the statement by Academician Sendov. Instrument production is carried out chiefly with extremely insufficient forces in the units themselves of the Unified Center in parallel with significant research and development work of developing the new instruments, technologies and elements. In a certain sense, with the current organization of work, these two activities contradict one another and can even be mutually obstructive. For example, even in the Central Laboratory for Automation and Scientific Instrument Building, the production of the mentioned systems has taken away the main forces and time and prevents sufficient forces from being transferred to more promising problems in newly developing areas of automation.

Unfortunately far behind is the construction of enterprises for scientific instrument building under the BAN. At present, it is impossible to say when it will have its own facilities in Sofia. At the end of last year, the base of an affiliate of the enterprise for scientific instrument building of the BAN was built and put into operation in Plovdiv. At present, it is a question of organizing and implementing the production of a number of instruments as well as those developed in the units of the Unified Physics Center. Also in Plovdiv work is underway on a small enterprise under the BAN for sensors and sensor devices. The former production section under the Laboratory for Applied Physics in Plovdiv will be transferred to it. This enterprise will play the role of an intermediary between this laboratory and the established new plant for sensors and sensor devices. With greater concern and attention to the interdisciplinary problems of scientific instrument building on the part of all the leading bodies of the academy as well as outside of it, there is an opportunity in the future to realize much greater results.

The good showing during the report year of the units of the Unified Center as well as the other units of the BAN at the major international exhibit in the area of scientific instrument building of the CEMA nations, the International Scientific Conference and Exhibit "Scientific Instrument -- CEMA 84" in Plovdiv, shows the significantly increased capabilities of the center's units

as well as other units of the BAN in the area of elements, materials, instruments, production devices and means of automation in scientific instrument building. At present, the slow introduction into production of this equipment prevents the use of these opportunities and the obtaining of a much greater scientific-technical and economic effect from them. Better collaboration between the different units is a major reserve for the more rapid development of scientific instrument building. In this regard we might mention the beneficial collaboration during the report year between the Central Laboratory for Automation and Scientific Instrument Building under our center and the Institute for Engineering Cybernetics and Robotics under the Scientific Trust for the Basic Problems of Technical Sciences.

The role of collaboration in the area of scientific instrument building with the leading institutes abroad and primarily in the Soviet Union is also to increase, for example, with the Institute for Automation and Electrometry in Novosibirsk in the area of automation, with the Physical-Technical Institute in Leningrad in the area of molecular epitaxy and so forth.

Secondly, as is known, optical electronics arose on the basis of photoelectric phenomena and certain units of our center have old and good traditions in the research and application of this. Even in the General Physical Institute and after this in the institutes and laboratories split off of it, interest in optical electronics held an important place. The conditions in the BAN and in our nation, however, for a long time did not permit these activities to develop more broadly and more comprehensively and to produce a significant economic effect.

The new stage in the development of optical electronics which occurred after the discovery of lasers even in the 1960's was quickly reflected in the work of the physics units under the BAN. But here the pace at which research and development have developed in recent years and particularly the question of introduction has been extraordinarily slow.

Six years ago with the founding of the Laboratory for Applied Physics in Plovdiv, it was decided to focus a large portion of its activities on research and development work and on small-series production in certain promising areas of new optoelectronic elements.

Last year our nation drew up an overall plan for the advisability of rapidly developing optical electronics. Units from our center also took a substantial part in its elaboration. On the basis of it, at present a new national program for optical electronics and laser equipment has been worked out. Unfortunately, this program in its present state suffers from many shortcomings of the preceding ones. It does not give sufficient room to the units of the BAN, to fundamental research, new most promising developments in the area of optical electronics, laser equipment and modern video equipment. This requires that the BAN Presidium adopt a decision to establish a special Problem Council on Optical Electronics and Laser Equipment. It is essential that this decision be carried out more rapidly and this council begin its activities of coordinating and organizing the work of the BAN in this important area of science and scientific-technical progress. The first task of this council must be to adopt a separate program of the BAN for fundamental

and applied research and for development activities and small-series production in the area of optical electronics, laser equipment and video equipment.

The units of the Unified Physics Center have sent in their proposals for incorporating their work in such a program up to the end of the following 5-year plan. In the future, it would be advisable that this program be gradually broadened with problems from other important areas of modern wave microelectronics in close relation and cooperation with optical electronics.

Thirdly, the report of Comrade T. Zhivkov at the February Plenum emphasized that fundamental research is the basis of scientific and technical progress. At the same time, the important conclusion can be drawn from this report that at present in addition to the classic stimulus to fundamental research, the internal logic in the development of science itself, the needs of practice are also assuming ever-greater importance as an incentive for the development of this research. There is ever-stronger feedback between the end stages of the cycle of fundamental research -- applied research -- development activity -- introduction -- production.

One of the most vivid examples which will illustrate this new pattern, as was emphasized by Comrade Todor Zhivkov, is the interaction between modern solid state physics, or more generally the condensed state of matter, and modern microelectronics. Microelectronics has long become the main incentive for the development of solid state physics. However, the coming change in microelectronics toward the submicron sizes of the elements in the integrated circuits requires the carrying out of a number of new fundamental studies in the area of statistical physics for these dimensions, as well as in the area of quantum mechanics, for example, of two-dimensional and unidimensional condensed systems and so forth.

In the new areas of microelectronics, optical electronics, acoustical electronics or, more generally, wave microelectronics, further progress also requires thorough fundamental research on the propagation of the diverse microwaves, condensed media and systems and their diverse interactions with such propagation. In the more distant future in the integrated circuits individual macromolecules will begin to play a role as electronic elements. The achieving of this new stage in microelectronics which even now is called molecular microelectronics also involves a number of fundamental studies in the area of molecular physics, quantum chemistry, bionics, molecular biology and bioengineering. From everything it seems that in the area of microelectronics the fundamental research will never be separated from applied research while the research, development and production activities will always remain inseparably interlinked.

In the most advanced countries close ties and complete cooperation have long been established between condensed-state physics as well as between a number of other areas of physics such as physicoelectronics, radiophysics, optics, nuclear physics and microelectronics. However, in our nation from the very start of the development of microelectronics this interaction has been neglected. In many socialist countries the development of these two areas has occurred simultaneously and recently a tendency can be observed, primarily in

the Soviet Union, of strengthening the involvement of the academy units and fundamental research in the development of the elemental base, the materials, apparatus, production equipment and new production methods in microelectronics. Obviously, it would be advisable to encourage this trend in our country.

Hence, more than any other time it is essential to strengthen the interdisciplinary approach in the work of the units of the Unified Physics Center in the basic areas of science and scientific-technical progress, to more closely link fundamental and applied research, research, development and start-up activities; in the academy itself and in the Unified Physics Center certain production units must be appropriately developed and where a portion of the results of our activities will be brought to completion; ties are to be strengthened between the units of the Unified Physics Center as well as ties and our joint work with similar units outside the center and BAN; international cooperation is to be significantly deepened on the crucial questions of the scientific and technical revolution, primarily with the Soviet Union, and its effectiveness increased; it is essential to overcome the bad influence of the poor physical plants of the units of the United Physics Center on the effectiveness and use of the skill capabilities of the scientific workers; unity of action between the various bodies in the BAN and outside of it must be improved in resolving the major questions of scientific development; bureaucracy must be reduced and discipline, organization of work and efficiency improved in utilizing the time and skill of the scientific workers and specialists.

**Senior Science Associate Vasil Sgurev:** Several years ago at a session of the General Assembly of the BAN, our first leader, Comrade Todor Zhivkov, pointed out from this rostrum as the main task of the academy in the area of applied research, the concentrating of efforts on developing new sectors and subsectors of industry for more widely multiplying our achievements through mass series production. At the moment, undoubtedly, this idea has even greater pertinence.

I would like to take up just one question, namely the several problems of introducing into series production and industrial robots and personal computers developed at the Institute for engineering cybernetics and robotics under the BAN.

Last year, the Beroe Plant in Stara Zagora, using specifications and with the active involvement of specialists from our institute, produced the first several-score robotized welding complexes RB-250. At present, they have been installed in crucial plants in the USSR and up to now have been operated without complaint. This robotized complex with a five-processor hierarchical control unit and with 90 of freedom is one of the most complicated units produced by our machine building. It is a success of the collective and at the same time of the entire academy, because, while up to now only one academy institute was actively involved in heavy machine building, namely the Institute for Metal Sciences and Metal Technology, at present we have been able to make our own contribution, too. At the same time, it must be pointed out that putting an original complicated article into series production in a short period of time with cooperation of five plants is no easy job and

requires the appropriate organization and mobilization of the collective, long, fatiguing official trips, significant efforts from the ministry, its divisions and the appropriate okrug BCP committees or, to put it figuratively, all this involves many forces and much nerves.

Last year, some tension arose in robot building when under the purchase license for the mechanics of the Fanuko-robot TB-240, due to embargo considerations, the Japanese side refused to deliver the microprocessor control devices. The possibility of Bulgarian exports of these serially produced robots would have suffered seriously with a good market available in the CEMA countries.

Upon a request of the leadership of the Ministry of Machine Building, the Institute for Engineering Cybernetics and Robotics together with other divisions of the ministry is engaged in developing a new model of the microprocessor control as a rush project. These activities have taken up a significant part of our collective. Difficulties were overcome related to the fact that the demands for control reliability of the robots are several-fold higher than those for conventional computer equipment. Many of these difficulties have already been overcome, industrial testing is successfully being carried out and very soon we will begin assembling the RB-240 with new Bulgarian controls. This success is even more desirable because it has been achieved in a competitive struggle with other collectives in the country.

I would like to say several words about personal computers. It is an indisputable fact that the BAN was the first to realize the importance of personal computers which through the world have had a truly revolutionizing impact upon the production and wide application of computer equipment. In essence from the Imko-1 and Imko-2 personal computers developed by the ITKR [Institute for Engineering Cybernetics and Robotics] and produced at the institute's experimental plant in 1983 in a run of several hundred, we have begun their industrial production. Complete specifications were turned over to the instrument building plant in Pravets which with active aid from academy specialists last year produced over 5,000 units under the name of Pravets-82. Over the next few years the production of this subsector must reach a volume of several hundred million leva.

I cannot help but point out that our collective views this primarily as a success of the BAN in developing new computer equipment since, as was repeatedly pointed out by Academician Lyubomir Iliev at the BAN General Assembly, for many years it [the BAN] did not have an opportunity to take an active part in these activities. It must be stressed that this has been largely aided by the new leadership of the Ministry of Machine Building which has provided an opportunity for the institutes outside this department on a competitive basis to participate in the development of series-produced computer equipment. Undoubtedly this is a positive phenomenon for us, for the establishing of a monopoly situation for any collective whatsoever does not lead to good results.

In returning to personal computers, I would point out that in no instance should the impression be gained that the way to developing them is a smooth one. In essence, the real difficulties are starting now because our nation

needs a strong component base as well as modern peripheral equipment and this is a major problem which is already receiving the attention of the Ministry of Machine Building as a whole, as well as many organizations in the nation.

For our institute a positive role is played by the Pravets Economic Association which, along with our institute and the instrument building plant in Pravets, includes the Instrument Building and Automation DSO [State Economic Trust], the BISA [expansion unknown], the Bulgarian People's Bank and the Equipment VTO [Foreign Trade Organization]. Within this association the institute is responsible for development activities and for providing new models for production.

While our 8-byte personal computer has gained wide recognition and is employed in the country, in the area of the 16-byte machines work is being done by various collectives in different departments and we are making a major effort for the plant to be able to enter the market with a compatible product. By the end of the year the institute's Experimental Plant at the Pravets Instrument Building Plant will produce a test series of several hundred Imko-4 or under the plant name of Pravets-16 as well as its industrial modular version the MIG-16 or Pravets-16M which, we hope, will gain the broadest distribution and use.

Our efforts over several years to begin series production of industrial robots and personal computers provide an opportunity to draw the following very general conclusions:

- 1) Serious attention must be given to the need of our academy institutes in the area of engineering and natural sciences to focus their efforts on initiating mass industrial production as here our nation would gain the greatest economic effect. However, no one must be simply allowed to do this without first investigating and adapting flexibly to the specific requirements of industry and to actual reality. For this purpose we must have a well developed design potential which is capable of preparing the technical specifications according to standard requirements in industry. The institute is endeavoring to constantly raise the role and capacity of this potential, very often also at the expense of the main scientific units and activities. We must also have well developed marketing units and departments for import and export which will provide an opportunity to correctly direct new developments in accord with market requirements and will promptly provide the development of new products with the necessary models and components; the availability of a well equipped and well staffed experimental plant which would be capable of producing test series for market sampling and for creating complete specifications, products and production methods for rapid introduction in industrial plants. This has been the experience of the Welding Institute imeni Paton in Kiev which we will endeavor to follow.

- 2) The academy institutes should pay attention to the use of the form of economic association envisaged in the new economic mechanism. Our 9-years experience with the Pravets and Izablan Associations indicate that this form provides good opportunities for a more immediate interest of industry in new developments and on the part of the institutes also for participating in .pa

profits. In our opinion, in many regards this form is more advantageous for the academy even with small enterprises.

Certainly, what has been set out above is no formula for solving all the problems of shifting our fundamental research to introduction into industry.

Finally, I would like to make a recommendation. The submitted accountability report of the 1984 activities of the BAN undoubtedly reflects significant accomplishments by individual units and divisions. But possibly the time has come for us, like the Soviet and other academies, to write in the accountability report about an achievement aimed at fundamental or applied scientific research only when final results have been obtained. At present, in several accountability reports running one can encounter the same developments and for these at times it is not clear when they will be completed.

Permit me, finally, on behalf of the ITKR under the BAN to assure the General Assembly that we will fulfill the obligations assumed for the current five-year plan.

**Prof Doko Dokov:** The current BAN General Assembly is of particular importance not only for the Academy of Sciences itself and for its individual units but also for the entire scientific front, since it is being held just 2 months after the historic February Plenum of the BCP Central Committee which outlined the scientific and technical policy of Bulgaria and the strategy for realizing it. Since the BAN is the largest and most comprehensive scientific organization in the country and responsible for fundamental research and simultaneously takes an active part in carrying out nine other national scientific research programs, it also, correspondingly, bears greatest responsibility among the other scientific organizations for correctly carrying out the nation's scientific policy, for the development of scientific and technical progress and for a decisive improvement in scientific services for the national economy and all social practice.

When a person reads a large and informative accountability report concerning the results achieved in scientific research and scientific introductory activities by the academy collectives during the previous year and compares this with the reports from the 1960's or even the reports from the years of the Seventh Five-Year Plan, he will see the entire growth of the academy and the major contributions which have been made by many of its units now. Precisely this growth determines the ever-increasing authority of the academy both within the country and abroad and as a result of this it is already a desired partner of the largest and most famous scientific organizations abroad and is sought out by our industry and by our economy.

Also making a specific contribution to the successes achieved by the academy collectives are the academy party organization and the other social organizations in the academy including the trade union, Komsomol and others. At the same time, the party organizations, the trade unions and the Komsomol bear appropriate responsibility for the weaknesses permitted in our work and for unsolved problems.

The report of Comrade Todor Zhivkov to the February Plenum which elaborated new concepts and approaches for the party in the nation's scientific policy as well as the strategy and policy approved by the plenum for the development of science and scientific-technical progress and for reorganizing the entire scientific front from the viewpoint of the new demands to increase the effectiveness and quality of scientific research and introduction raise much higher demands and many new problems for the party, trade union and Komsomol organizations in the BAN. First of all, there is the task and responsibility of the party, trade union and Komsomol organizations within their competence and employing their own specific methods and means to assist and help the academy leadership as well as the leaderships of the individual academy units in carrying out the reform of the scientific research front, the management of science within the BAN system and scientific research activities themselves in accord with the decisions of the February Plenum.

The decisions related to improving the organization of the scientific research process and the management system in the academy are within the competence, certainly, of the academy leadership and the appropriate superior bodies, but the party organizations, like the other social ones, have their specific functions and tasks related to improving the organization of the scientific research process and the management of the scientific units. These specific tasks have been set out clearly in the report of Comrade T. Zhivkov to the plenum as well as in other party documents.

Let me take up certain specific tasks which are directly tied to the contribution of the party, Komsomol and trade union organizations and which stem from the February Plenum.

Standing in first place, I feel, is the problem of making changes and improvements in the system of ideological-political and indoctrinational work among the scientific and other academy collectives in the aim of further raising the level of their social activity and self-initiative and their interest in carrying out a reorganization in the BAN system as well as in the entire scientific front. In this regard it is essential to bear in mind that the collectives in the scientific organizations can carry out the tasks posed for them by the February Plenum if they reorganize their work and if the way of thinking of the personnel is changed.

Another important problem which confronts the social organizations and primarily the BAN party organization in the context of the February Plenum is an improvement in their work and increasing their contribution to broadening the participation of the scientific and other collectives in the managing of scientific research and introductory activities, in the various collective management bodies of the scientific units for broadening the use of direct democracy in BAN management and enriching the forms by which direct democracy is carried out in the field of scientific management. These forms presently exist. They must be carefully studied and new forms sought out which practice itself will suggest. As for the involvement of the scientific and other collectives of the BAN in the management of scientific research activities and their improvement, there still is a number of unsolved problems which restrict the activity of the various collectives and represent a serious impediment in optimizing the scientific research process.

The question of broadening democracy in the management of scientific activities is far from settled merely by instituting the General Assembly as an institution or at production meetings and has a much broader scope. For precisely this reason this question merits special attention now, when drafts are being worked out for a reorganization in the scientific institutions and in the academy itself.

Another important obligation for the social organizations in line with carrying out the decisions of the February Plenum is creating the necessary conditions for the creative application and realization of the idea developed by Comrade Todor Zhivkov as proprietor and owner and more specifically of establishing the scientific and other labor collectives in the BAN as their own masters. However, it must be emphasized that here there still are a number of unsolved problems of a psychological, administrative-managerial and other nature, most of which are outside the academy and which obstruct the realization of this idea within the system of the BAN. The social organizations and particularly the party organizations are obliged to show much more self-initiative and do much more in this regard in order to overcome certain psychological and other barriers in providing direct aid to the academy leadership.

An important obligation for the social organizations in the BAN is to increase their contribution to further strengthening discipline in the scientific collectives and in the administrative-managerial units, to improve the sociopsychological climate as an important reserve for increasing the effectiveness of scientific research activities and for carrying out the decisions of the February Plenum. This is a very important factor which, without additional funds and capital investments, can produce a significant scientific, economic and social effect. For this reason, we propose a special discussion of this question together with the academy leadership, the Presidium and the leadership of the social organizations and the adopting of common measures to further improve scientific, technological and production discipline.

Here we have posed the question of discipline in the broadest sense of the word. Also within this context is the question of the time budget of a scientific worker. Eight years ago a work group under the leadership of Academician N. Yakhiel made a very representative and profound sociological study. This study showed a great wasting of time on the part of scientific workers in other activities not related to scientific research and introductory activities and having nothing in common with such activities. The decisions adopted at that time produced positive results. This study showed, among other things, that the scientific workers lose a great deal of time in resolving their own personal and collective sociodomic problems. In order to solve these problems and save time, for the first time within the system of the academy and the other scientific institutions, the BAN leadership, the party and trade union committee adopted a program for the social development of the collectives. I will not take up its importance and fulfillment.

Upon the proposal of Comrade P. Dyulgerov at the report-election conference of the constituent trade union organization, a proposal was submitted to the

Central Council of Bulgarian Trade Unions to resolve certain important but undecided sociodomestic problems of the collectives, for example, public health facilities, a solution to the housing problem, recreational facilities and so forth.

The decisions which were adopted in line with the sociological study have not been ultimately carried out. A great deal of time of the scientific workers at present is lost by the presence of bureaucracy and by a number of other unsolved problems. It would be advisable to continue the struggle to surmount these bureaucratic manifestations and more specifically to continue the struggle to carry out the decisions adopted after this sociological study as well as to make a new study under present-day conditions and on its basis outline measures for the most efficient use of working time and for an optimum budget of the scientific worker.

The leadership of the social organizations in the academy are fully aware of the great tasks which have been posed for them by the February Plenum as well as of the great responsibility which confronts them in carrying out these decisions within the academy system.

**Corresponding member Stoycko Panchev:** As a new member of the academy and a representative of a scientific area, atmosphere physics or meteorology, I would like to raise several questions related to the theme of the meeting.

At present, all sciences more or less are international, even those which are related to a certain nation. For example, Bulgarian studies. But possibly meteorology is the most international of all sciences.

People live on our planet separated by states, by political, geographic and other frontiers. However, there are natural factors which are in common, which link them together and serve as the basis for other ties: these are rivers, seas and oceans. But at times they are not included within any frontiers. Undoubtedly the atmosphere is the most international factor in human life. It does not recognize any frontiers in its movement. From this also derives the special position of our science. Many of its scientific problems recently have assumed the nature of immediate social imperatives from society for it. Some of these are resolvable on a national scale and the results can be adapted to other countries and geographic conditions. Others require the joint efforts of many countries. I will comment on two examples where specialists from the BAN and Sofia University during the academic year achieved something. This is the research related to protection against harmful atmospheric phenomena such as hailstorms, droughts, frosts and so forth.

World agriculture as an annual average suffers losses from hailstorms amounting to 2 billion dollars. At present, 20 percent of our total arable land is protected against hailstorms and there is a tendency to broaden this in the future. Up to 1981, the scientific support for this national measure was the concern solely of the Institute for hydrology and meteorology under the BAN. Proceeding from its importance, upon the initiative of Sofia University, a long-term coordination program was worked out and implemented and this brings together specialists who are physicists, meteorologists,

mathematicians, engineers, technical assistants and others from Sofia University, the BAN, the Directorate for Combating Hailstorms and others from the main financing organizations such as the Council for Higher Education and the State Insurance Institute. The main aim of the program is to increase the effectiveness of antihail protection in Bulgaria. The first part of the program encompassed the 1981-1984 period, and was completed ahead of time in March 1984 in honor of the National Party Conference on quality. A special collection was published with the results. Some of these have been introduced into practice by the Directorate for Combating Hailstorms in 1984. As we are the only country aside from the Soviet Union which provides commercial protection against hailstorms using equipment and a method basically taken from the Soviet Union, the results of our activities are not only of domestic importance but much wider. Let me point out that in the program of the forthcoming World Conference on the Control of Weather which will be held this August in the United States, five papers have been included by our collective on the results of our national program.

In seeing the advantages of an integrated approach in solving such problems, an approach which is presently recommended as an official policy in organizing scientific research, the established collective is continuing to work on the second part of the program which covers the period 1985-1987. In addition to the problems of combating hailstorms, there are also those of artificial rainmaking and the forecasting of frosts and hoarfrosts in the aim of providing protection against them in the not distant future.

I feel that these activities and this example of really joining forces around an important scientific problem can be found, albeit slightly, in the academy's report for last year. Incidentally, the entire area of meteorology was not reflected in this report.

The second problem where our work, however, is in the initial phase is tied to studying climatic changes. As is known, constantly acting astronomical factors cause the climate to follow, generally speaking, a calendar schedule of seasons. Anyone can predict that there will be a thaw after winter. This is a trivial forecast. It is much more difficult to predict months in advance whether the coming spring or summer will have approximately normal warmth, be dry or rainy, that is, predict deviations from the norm. In meteorology these deviations are called short-period fluctuations in the climate with a period from a season to a year. Of indisputed importance is this type of meteorological forecast for correctly choosing the strategy for work in agriculture, construction and industry. At present, our science does not possess reliable methods for such forecasts. It turns out that we still have little knowledge of the main guilty party of these fluctuations over Europe, the Atlantic Ocean. In line with this, the Soviet Union for 4 years now has been carrying out its own grandiose program called "Sections" and since 1984 our specialists have been taking part in the Atlantic portion of this program. They include physicists from Sofia University and the BAN. Our participation will continue until 1990. In addition to this, we are also participating in the elaboration of theoretical models and the processing of data from the observations. It is possible that these activities will be related to the recently increased interest in our country in the hydrobiological problems of the Southern Ocean as well as the Antarctic. I appeal for support for these

activities and initiatives from the leadership of the BAN, Sofia University and from higher authority.

**Academician Kiril Bratanov:** Allow me first on behalf of our scientific community, on behalf of the Union of Scientific Workers in Bulgaria which is a representative of the social [volunteer] principle on the scientific front, to congratulate you, the scientific collective of the BAN for the noteworthy successes achieved in 1984 and wish you new accomplishments in further raising the name of Bulgarian science.

When one reads the accountability report concerning the activities of the academy during the last year, one sees how all-encompassing and how broad the front of activity of the BAN is and the fact is reconfirmed that the BAN remains the leading center of Bulgarian science.

For us, the scientific workers, the February Plenum of the BCP Central Committee, was the event of the year as it discussed and approved the introductory speech and report of Comrade Zhivkov as well as the decisions concerning Bulgarian scientific and technical policy. In actuality it was an historic event which concerns not only science and technical progress but also the construction of our integral material and spiritual culture.

The report of Comrade Zhivkov is an unique document. As many times as one reads it one always sees new aspects, new interesting problems which precisely indicate its strength, its all-encompassingness, purposefulness and scientific soundness. It is a creative program for the improvement, development and management of science and technical progress and not only during this year but for the next two decades.

The report provides many valuable, original and, I would say, revolutionary scientific elucidations of problems involving the structure and organization of both fundamental and applied scientific research. With good reason I was strongly impressed by the fact that the Politburo of the BCP Central Committee assigned four sessions to these documents, the report and introductory speech. In this fact the scientific workers can see and feel the great concern of the party for Bulgarian science. This fact inspires and heartens us and gives us strength for our future work. But at the same time it places on us, the scientific workers, great responsibility, namely, turning the revolutionary thoughts and fine ideas voiced at the February Plenum into revolutionary action, into real undertakings. This is the main task which the February Plenum has posed for all the scientific community but has been addressed with particular force to the scientific workers in the BAN system.

I would like very briefly to take up certain questions related to the development of our science as these undoubtedly will involve the future activities of the academy.

The first is the question of creating a state-social principle in the management of science and technical progress, that is, a functional unification of the state scientific units with the social [volunteer] scientific organizations such as the Union of Scientific Workers and Scientific Societies in Bulgaria. There is a long-felt need of establishing a

united national front in the area of science and the setting up of special associations. The establishing of the Association for Scientific and Technical Creativity is beyond dispute and in it the BAN must take its worthy place as the leading scientific center in the nation.

The second question relates to the organization of scientific activities and to the specific program approach in scientific research and the role of the program collectives and councils. The program collectives which have been set up on an interdepartmental principle will carry out their activities on specific planned bases, let us emphasize, integrated bases, bringing together different specialists who are the best in the appropriate field. In possessing independence, a physical plant and financial assets, these program collectives will be able to create effectively and most importantly their developments will find a place in production and in life. There will no longer be a vacuum, there will no longer be a "no-man's land" between the individual developments, between the completed and printed work and introduction.

In reviewing the organization of scientific activity and planning, I feel that attention must be paid to the question of the scientific elaboration of so-called high-risk subjects. At two meetings of the Presidium of the Union of Scientific Workers with Comrade Todor Zhivkov last year, the question was raised of revolutionary thinking and revolutionary action in the area of science. On this question both in the press and in a number of party documents specific tasks were posed for the scientific workers. Certain revolutionary ideas in the area of science are manifested in the high-risk subjects. Usually the leadership of the institutes underestimates the proposals to include for development new ideas which sometimes truly are bold and risky, that is, revolutionary, but they must be reasonable and rest on a scientific basis. Some feel that high-risk subjects should not exceed 10-12 percent of the total volume of scientific research activity in a given unit. Whatever the number, they must be. They must be provided with financing. Some call the high-risk subjects for new development fantasies. However, risk is essential in science and particularly in the area of applied sciences. This is the result of revolutionary thinking but it must rest on scientific bases. And now valid sound the words of the great French scientist, Prof Frederic Joliot-Curie, voiced more than 30 years ago: "In science we must not clip the wings of bold ideas, of daring, sometimes the span of the wings, as the poet says, leads to the goal."

In the historical development of science there are scores of examples where bold ideas have created epoch-making discoveries. At the outset they were met with resistance, they were viewed as fantasy and some even as heresy. After, when life had confirmed their value, when they had been realized, it became clear that they had brought epoch-making discoveries and great glory to their discoverers. We might mention the great discoveries of Leonardo da Vinci, Galileo, Copernicus, Louis Pasteur, or the great Russian scientists Mendeleev, Popov and Meshenkov who left epoch-making discoveries and which at one time were denied.

In pointing out these brilliant examples in the history of world science, we do not mean to imply that we, the scientific workers in Bulgaria, are expected

to constantly prove ourselves as new Galileos or new Pasteurs. No! We, the scientific workers, in our scientific institutes and laboratories are expected to show greater dynamicness, to bestir the gray matter, particularly of the younger personnel, in a bolder and more revolutionary manner, to formulate new original ideas, to get away from routine and a deep rut, as Comrade Todor Zhivkov said, and to come up with new, original proposals for resolving important problems. And if a certain Pasteur or Galileo is born, this will be a pride for Bulgarian science. Undoubtedly his ideas will find ground for flowering and producing fruit and will bring glory to the motherland. This is how the problem of risk-taking ideas must be understood in science. If a realization is born from a certain risky subject, undoubtedly this is a good thing.

In examining this question, it must be pointed out that we have many instances of revolutionary scientific ideas where there is risk and the discoveries which developed initially were met by the specialists and departments with resistance and even complete denial. There is the vivid example in this regard of Academician M. Popov. His theory concerning the application of biostimulants in plant raising for a long time was denied and only after his death, when this theory gained full recognition and respect abroad, was it considered original and exceptionally valuable. At present, this brings glory to Bulgarian biological science throughout the world. Biogenic stimulants have already found wide concrete application and each year from their employment tons of higher-quality product valued at millions of leva are obtained.

I would like to take up certain specific problems and production methods which are being worked out in the academy. It is a question of the so-called biotechnology [bioengineering]. This term has not only come into use but has widely invaded our lives.

I would like in a couple of words to say how we should understand biotechnology because various interpretations of this term have been given. I would give a biological definition, that is, biotechnology is a hybrid between a living biological process and an industrial technology. These are combined into one and biotechnology results. There are two components: biological and technological. This hybrid, in the first place, must bear fruit and secondly in no instance does the biological component or industrial method hold down the biological process, be this multiplication, development, growth or a product, but must stimulate this. This principle is the most important. In the academy many biotechnologies have been worked out and particularly in the area of the biology of multiplication. Technologies have been worked out on six levels: molecular and gene, cellular, tissue, on the organism level and on the level of populations.

I would like to say two words on the techniques of embryo transplanting, a question on which much is also being written and much said. Some 7 years ago (1978), the BAN Presidium adopted a decision to establish a special laboratory for the transplanting of zygotes and embryos at the Institute for the Biology and Immunology of Reproduction and the Development of Organisms Under the BAN. Some were against this, but the Presidium showed good foresight. Since that time, we have begun a study of this method and research in various aspects

including morphological, immunological, biological, biochemical and so forth, and in 1980, the first embryo was obtained in the village of Ruzhevo Konare. On 8 March the first calf was born and it was named after the woman's holiday, Martha. Today Martha is a cow and has already given birth to two calves. At present the method of embryo transplanting is being developed jointly with the Academy of Agricultural Sciences. This development can be pointed to as an example of fortuitous collaboration between two academies on one exceptionally important and promising problem.

In conclusion I would like to take up a question which is exceptionally important for the development of our science, namely the question of the introduction of scientific achievements into practice and production and the complete and integrated use of the biological reserves which Mother Nature holds for us. It is a question of the resistance to this introduction. On this question in his introductory speech at the February Plenum, Comrade Todor Zhivkov said the following: "In spite of the efforts which we are making for the development of science as a productive force, powerful forces have sent a hydra-headed monster against it. They are the present bodies involved in planning, financing and managing the economic organizations, that is, those which are empowered to take decisions on the introduction of scientific and technical achievements. By their work methods they usually not only do not assist and do not encourage the development of scientific products but often frustrate the use of completed scientific products. Obviously, it is easier to follow a well-trodden path, to plan and produce using only available equipment and not take risks and assume additional obligations." Everyone must fight against this hydra-headed monster -- the scientific workers, the party figures, the social and economic leaders. It must not be forgotten that this is one of our main tasks.

**Prof Petur Ignatov:** The leadership of the BAN is presenting to the General Assembly an impressive balance of what was accomplished in 1984 not only for fulfilling the scientific research plan but also the academy's entire activities.

The conditions for obtaining the high results designated in the report were created in preceding years. They are the fruit of the life-affirming Leninist April policy of the BCP Central Committee which the leadership of the academy and its personnel have carried out continuously. Precisely by this and due to the mobilizing and organizational work of the leading cadres in the academy, the party bodies and organizations, the public organizations and the personal efforts of the scientific personnel, the significant achievements can be explained in the area of fundamental research and particularly in such a difficult area as the introduction of these results.

Echoing the general successes of the academy, in 1984 the Institute for Water Problems achieved definite positive results in carrying out the plan for scientific research activities. The collective of this small academy institute is at work in a delicate and tense area of science designated by the general term "water problems." Undoubtedly, among the most essential of these we would consider the problem of optimum utilization and the protecting of water resources against pollution.

As is known, the deepening scarcity of fresh water is becoming a global problem for all mankind. It is particularly acute for nations with limited water resources and with a rapidly developing economy such as Bulgaria. At present, there is the widespread opinion that the development industry, agriculture and public amenities and landscaping in population points in the near future will be limited by the lack of sufficient and high-quality water resources. Unfortunately this threat also exists for our nation.

In order to avoid or reduce this threat, even now we must carry out a complex range of specific measures in the scientific area and on the practical level. It is essential to alter certain traditional approaches in the planning, designing, exploitation and conservation of water resources against pollution. In the aim of satisfying these requirements, in the special-problem group "The Optimization of Water Management Systems" we have created new or improved a number of existing methods in the area of the hydrological principles of water management research, in controlling run-off and compiling the water management balances, in optimizing the parameters of the water management systems and so forth. By these developments for which over 40 programs have been compiled and a portion of which are being introduced by our design organizations such as Vodproekt [Water Works Designing Enterprise], Vodokanalproekt [Water Supply and Sewage Planning Service] and others, the institute is recognized as the leading unit for water management research in the nation.

Research on the static and dynamic behavior of hydraulic engineering works and their strength is another, also widely represented area of scientific activity for the institute. On the basis of the theory of elasticity, rock mechanics, the theory of heat conductivity and with the aid of numerical methods, the Institute for Water Problems has developed mathematical models and packets of computer programs designed for examining the stressed and deformed state and strength of underground and above-ground hydraulic engineering works. The packet of programs has been employed repeatedly in design practices for the research and acceptance of design decisions for hydraulic engineering and other civil projects and in certain instances a major economic effect has been obtained. For example, the NIPIES Energoproekt [Scientific Research Planning and Design Institute for Power Systems] has investigated the wall of the Anton Ivanovtzi Dam, the underground reinforcing of the Kurdzhali Dam, the cavity of the Chaira PAVETs [pumped storage hydropower plant] which as a plant of this type is one of the largest in Europe in terms of its scale.

The use of the programs worked out by us at Vodokanalproekt has led to a significant economic effect. Thus, in designing the Cherni Osum Dam wall, due to the research conducted at the Institute for Water Problems, it has been possible to change the initially adopted type of dam wall from cite-cast to cite-cast with lightening joints and this has provided an effect of 4,396,000 leva.

One event which was at the center of our work during the previous year was the letter from Comrade Todor Zhivkov to the Politburo of the BCP Central Committee concerning the accelerated development of irrigated farming in Bulgaria up to the year 1995. In terms of its content this was an exceptional document in which Comrade Todor Zhivkov penetratingly analyzed the problems of

irrigated farming and water management on the basis of profound Marxist-Leninist analysis and from the standpoint of the new integrated approach.

This program document which outlines the party's agrarian policy over the next few years has been greeted with enthusiasm by the entire collective of the Institute for Water Problems. A full-scale program was adopted which reflected the main areas of scientific research which relate to the problems of irrigated farming.

A number of measures were also set to help the Water Management DSO in Sofia, the Capital City People's Council and other departments in carrying out the adopted comprehensive program for the development of irrigated agriculture. At present, one year after the adopting of these measures, we can report the following major results.

Under contract with the Water Management DSO in Sofia, two types of automatic filters for drop irrigating were developed. The first filter was manufactured at the Plant for Purification Equipment in Kurdzhali and was installed on a plot at the Peshtera APK [agroindustrial complex]. The testings conducted on the filter during last year's irrigation season showed high and dependable results. A filter of the second size will soon be installed on a plot of the same farm for testing during the summer, after which they are to be introduced industrially.

The Institute for Water Problems together with the Institute for Mechanics and Biomechanics have worked out systems for hydraulically automated irrigation for farm crops. Last year, such a system was put in for trial testing in the village of Shtruklevo, Ruse Okrug, on an area of 100 decares. The obtained results provide reason to feel that in the near future the rain-making systems will be able to operate without the necessity of irrigator labor and personnel while the money for their construction will be around 120-200 leva per decare cheaper than the necessary expenditures for conventional systems.

In addition to the results pointed out up to now, definite advances have also been made in studying stationary and non-stationary flows under pressurized and non-pressurized conditions, of the channel and hydrophysical processes in rivers and reservoirs, filtration processes and so forth.

Progress has also been noted in the area of introducing the scientific developments. For example, let me point out that during the year work was done on 33 above-planned problems, under contracts with a value of 412,000 leva. For us the unplanned contracts have been a very successful form for introducing the scientific achievements. The presence of an interested party in the results of introduction, the acceptance of the developments by the investor's expert councils and the establishing of contacts between the two parties for the time of introduction -- all of this has improved the quality of the developments and increased the chances for success. This is why we are in favor of this form of collaboration. However, existing practices in establishing contractual value of including the full wage fund of the participating scientific workers leads to an excessive overstating of this value. At times, staggering figures for the value of the contract are obtained and this is beyond the capabilities of our investors. The situation

has further deteriorated after a decision was taken to increase the deductions for overhead expenses which double the value of the contracts as overhead deductions are 98 percent. With this situation inevitably a drop will be obtained in the concluding of contracts and this cannot help but have a negative impact upon the future introductions.

Lastly, I would like to state that regardless of certain objective difficulties, the collective of the Institute for Water Problems has succeeded in significantly overfulfilling the given promise, in realizing approximately 8 million leva of economic contribution instead of the promised total of 1,960,000 leva over the 5-year plan. Allow me to assure the General Assembly that our collective in the future will make its contribution to carrying out the great tasks posed by the party and the government for the BAN.

**Gencho Pirov:** Those of us who remember back farther, as I do, know that in the 1960's at the general assemblies of the academy it was usual to hear people arguing for establishing a psychology units within the system of the BAN. And in truth, although with some delay, at the beginning of the 1970's, a humble laboratory was established which now employs reliable young personnel and the prerequisites already exist for the establishing of an institute.

I do not intend to take up the work of this laboratory but I would like to point out two events last year which were linked chiefly to the decision of the Secretariat of the BCP Central Committee concerning the further use of psychological and sociological knowledge in life and practice. Last year a symposium was held on the territory of Kremikovtsi together with the Laboratory for Labor Psychology which exists there on the problems of the effectiveness and improving the quality of production. The second event was the Soviet-Bulgarian Symposium on "Psychology and Practice" and its subject was aimed at resolving the problems of daily practice. And actually specialized units have been formed at a number of enterprises. We have already made a start at establishing school psychologists, something where we have lagged far behind. Yet a start has been made to a useful and valuable activity.

Now I would like to plead the case for one other science which must take its place in the academy system. This is pedagogics, or actually pedagogical science.

Even in the founding of the Bulgarian Literary Society, the representative of this science was Yosif Kovachev who was the first teacher of this discipline in the then higher school. Later, when Prof Dimitur Katsarov was elected a corresponding member in 1947, he immediately took the initiative, with the assistance of Academician Todor Pavlov, in establishing a Pedagogics Institute, initially as a section under the then Department of "Legal, Philosophical and Economic Sciences," after which it became its own institute. Later the institute grew into a very richly developed unit. Later the institute was transferred to the Ministry of Public Education. Everyone who worked in the institute felt that the ministry had a right to its own departmental institute but the institute which had been established within the academy should not have been transferred. Our view was not accepted. The .pa

institute has been moved to the system of the ministry and at present is solving current problems there in this important area of human activity.

You all know that problems cannot be partially solved, as has been emphasized in the report and in the other statements. There must be fundamental research in this area and which one organization under the Ministry of Public Education cannot fully carry out. This problem must be taken up by the Academy of Sciences. For example, we are carrying out a major reform in education, transforming it in the spirit of the Theses but much of what is being done is being carried out very empirically, on a very unsound scientific basis and there is no solid scientific research on a number of problems which must be solved. Take the question of the all-round development of the human personality. In our country there has not been systematic work on this question and it is a fundamental problem. This also includes the questions of developing capabilities as the most precious capital of the people and particularly the abilities for creative activity. Take the question of linking instruction with labor which is a practical one but also has a theoretical basis which requires examination, or the recent trend of the computerization of education. Undoubtedly, the computer will become part of our life, it is already doing so, but we must admit that we are not ready for this. Neither pedagogical nor psychological sciences have made sufficient studies, and not only in our country but also in other nations, in order to see both the positive aspect of this computerization as well as the eventual dangers which it may entail.

These are questions which require a thorough study in order to avoid mistaken steps, steps which could compromise a valuable idea, a necessary step in the development of education. In future plans for reforms in the academy, I urge that we bear in mind the needs of the scientific discipline which works in this area of science.

**Prof Zh. Zhelev:** The materials of the February Plenum of the BCP Central Committee (1985) devote a special place to the problem of counterplanning in the area of scientific research and scientific services of the economy and all social practice in Bulgaria.

The role of counterplans in the BAN up to now has been successfully carried out by the pledges of the labor collectives which are a component part of the general pledge of the academy.

At the end of 1984, all units of the BAN reported on the fulfillment of the tasks additionally assumed in the pledges as well as other activities. On the basis of this I can report that the 1984 BAN pledge for the basic indicators has been fulfilled, that is, both in terms of the high quality and early fulfillment of a number of important problems under the Capital Program and the ten regional programs as well as for the additionally assumed scientific research and introductory developments and particularly those which contribute to increasing product quality, scientific instrument building, the popularizing of science and scientific achievements, patent and licensing activities, cooperation of the BAN with economic ministries and so forth.

For example, with the pledged 170 developments for introduction during the year, some 196 have been introduced while the pledge for working out and introducing new methods, devices, programs and so forth within the system of the BAN alone has been fulfilled by 200 percent, with 61 introduced instead of the promised 30. In the area of scientific instrument building and the production of automation systems for scientific experiments and production processes, I can also report the overfulfillment of the counterplans. Instead of the pledged additional product amounting to 400,000 leva, above-planned product worth 11,170,000 leva has been produced and this represents a 7.13 percent overfulfillment of the limit and two times the pledge.

In addition to this instead of the pledged over 600,000 leva, we have obtained 1,359,000 foreign exchange leva which corresponds to 128 percent plan fulfillment and more than 2-fold the fulfillment of the pledge or counterplan.

Not lastly, let me report that the 1984 pledge of realizing and documenting 80 million leva of an economic result has been fulfilled by 74 percent and as a total 126 million leva of an economic result has been achieved, while over the last 4 years of the 5-year plan the total has been 476 million leva.

The realization of these results once again confirms the correctness of the policy carried out by the BAN leadership of carrying out the instructions of the BCP Central Committee for turning science into a direct productive force.

On the basis of the contract concluded between the BAN and the Executive Committee of the Sofia People's Council concerning the requirements of the capital, 162 tasks have been carried out including 116 for industry.

On the basis of the pledges of the individual collectives for 1985 it is proposed that the General Assembly of the Academy approve the following pledge of the BAN collective for 1985 with an inseparable part of these being the collective pledges of the unified centers, scientific trusts and other units of the BAN.

#### 1985 Pledge of Academy of Sciences

Sofia SPISANIE NA BULGARSKATA AKADEMIYA NA NAUKITE in Bulgarian No 4, 1985  
pp 28-30

[Pledge of the Workers, Employees, Specialists, Scientific Co-Workers and Academicians of the BAN for Their Work in 1985 and directed to the BCP Central Committee, the Council of Ministers of Bulgaria, the Central Council of Bulgarian Trade Unions and the Central Committee of the Dimitrov Communist Youth League]

[Text] Pursuant of the Decisions of the 12th BCP Congress and the February (1985) Plenum of the BCP Central Committee and for properly celebrating the 13th BCP Congress, in the aim of increasing the effectiveness and quality of all their activities, the collective of the BAN pledges:

To effectively carry out the decisions of the February Plenum of the BCP Central Committee.

To increase the work planned for 1985, to shorten the times of the individual tasks, to pose and carry out additional tasks for research and introduction, to increase qualitatively the organization of our scientific potential and, respectively, the effective results from scientific research:

1. To carry out on an even higher scientific and scientific-technical level and with greater quality the tasks incorporated in the scientific research plan for 1985, particularly the tasks in the national and comprehensive-coordinating programs.

2. To complete above the plan over 120 additional research, applied and introductory projects.

3. To reduce by months the fulfillment of over 30 scientific developments for introduction and application.

4. To offer the economic ministries 40 new scientific developments for introduction and to take a direct part in the process of basing production on them.

5. To introduce within the BAN system over 40 developments as well as new methods, programs, instruments and so forth.

6. To carry out the 17-million-leva BAN production program with a higher level of quality (scientific instruments and automated systems for scientific experimentation) and produce 200,000 leva of additional product.

7. To give preference to the execution of those projects which contribute to higher product quality for the national economy.

8. In the area of social sciences to focus the forces chiefly on carrying out projects which will disclose the patterns of socialist relations and a mature socialist society, namely projects related to studying our historical past, our cultural heritage and its development; the formation of the socialist individual; the social and scientific-technical revolution; political-economic forces; the national economies; the unity of the Bulgarian language and the raising of it even higher as the most powerful means for showing Bulgarian scientific and cultural thought.

9. In 1985, to realize and document over 60 million leva of an economic contribution to the national economy to properly greet and report to the 13th BCP Congress.

10. To actualize the organizational-coordinating contracts with the economic ministries, to coordinate the tasks for the following 5-year plan and ensure one's part in carrying out the reciprocal obligations. To work to broaden and develop the contracts in the aim of turning them into long-range programs for reciprocal collaboration. To provide the participation of scientists and scientific workers in scientific management and in the leading bodies of the

ministries, trusts and enterprises. To assist in the application of advanced foreign experience by them and in carrying out the decisions of the February Plenum of the BCP Central Committee.

11. To improve the work on the regional BAN programs with the okrugs, in utilizing the most important results from the scientific activities on a national scale. Particular attention is to be given to the carrying out of the projects included in the Capital Program.

12. In 1985, to overfulfill by 20 percent for the 5-year plan the indicator of "new inventions in Bulgaria" and by 10 percent for the 5-year plan the indicator "recognized inventions."

13. To realize foreign exchange earnings of 3.9 million leva from the export of our own products, including scientific monographs.

14. To continue to work successfully in ensuring a high level of metrology and standardization of all activities within the BAN system.

15. To increase the exactingness of the scientific councils in reviewing and discussing the scientific contributions and effective results from research in theory and practice. To improve the encouraging of advanced results and criteria for carrying out the socialist competition between the BAN institutes.

16. To provide constant scientific and methodological aid for the young scientific workers and specialists in their professional, scientific development. To establish conditions for the more intensive development of personnel scientific potential.

17. To improve and concretize the work in assessing the effective involvement of the BAN in international collaboration; to prepare thoroughly and critically the plans for the following 5-year plan. To carry out in an exemplary manner the international measures for which the BAN is the chief organizer.

18. To broaden the volume and improve the quality of activities in popularizing the achievements of Bulgarian and world scientific theory and practice by original materials; to use more effectively the mass information media, exhibits, TNTM [Movement for Youth Technical and Scientific Creativity] and scientific seminars for propagandizing the BAN activities and the scientific achievements of the scientific units.

19. To develop the work on all levels for improving the organization of labor work and financial discipline in the scientific divisions.

20. To work out a concept for scientific aid from the BAN to secondary education. On the basis of this the unified centers, scientific trusts and independent units are to work out programs for their work in the secondary education system.

21. To improve the organization of labor of the workers; to strictly observe the requirements of labor safety, hygiene and aesthetics as well as socialist legality in all divisions.

22. To raise internal discipline and organization of the brigade movement, the Lenin Saturdays in agriculture and construction.

23. The collectives from all activities of the BAN are to fight to fulfill the adopted program for social development in 1985 as this remains an inseparable part of the current pledge.

Chairman of the BAN:  
(Academician A. Balevski)

First Secretary of the Party Committee:  
(Corresponding Member Z. Mladenov)

Committee:  
Chairman of the Academy Trade Union  
(Prof Zh. Zhelva)

First Secretary of the Komsomol Committee:  
(Senior Associate I. V. Ivanov)

#### Concluding Speech of Academician Balevski

Sofia SPISANIE NA BULGARSKATA AKADEMIYA NA NAUKITE in Bulgarian No 4, 1985  
pp 30-34

[Closing speech by Academician Angel Balevski]

[Text] First I would like to say a word on the report. I think that you will all agree that it provides a picture of what has been accomplished in the academy. We can never claim to have complete data. If we wanted to show all types of activities, all the accomplishments and everything which has been done in the economy we would scarcely be able to do this. Moreover, we are still encountering difficulties in the processing of materials which come from the unified centers and institutes. They do not always come in a form which gives a good idea of what has been done.

I would also like to say a few words on our concerns. Everything good which can be said has been said. But there are also many things which concern us. For example, the question which relates to the effectiveness of the academy as an institution. We are still unable to organize internal information so that each person uses it in his work, according to his specialty. We have been talking about this question for 10-15 years now. I realize well enough that it is difficult to implement such a system of internal information. I have been ashamed that we could not do this. But in a talk in the past with the Chairman of the East German Academy of Sciences, Herman Klare, and the Chairman of the Czechoslovak Academy of Sciences Kozesnik, I mentioned our

problem to them. They replied that they had the same one. The people, an individual scientific worker received more information from outside than through the academy. I feel that we can establish such a system. But in order to obtain information from anywhere there must be some place to provide it. We will entrust the people periodically with filling out charts, to turn in these charts but in this manner a difficult system will be established and we do not know whether it will always provide a clear notion of what the information is about.

One weakness which has appeared in the academy is the trend observable throughout the nation, that is, a desire of the individual institutes to work for themselves, all cut off. You know that an evil of ours is the establishing of departments which throw up fortress walls, unfurl banners and show neofeudalism. We must work as an integrally linked organism in the entire nation because we are one state, one society. We must adopt the form "we" and reject the "you." Our state has only a "we."

There are institutes which do certain things but do them for themselves. But another institute has long since solved these. For instance, the use of a certain method. People have used it for years while others do not know about it. Contact must be established. But in some places there is a zeal for "this is something I must do completely myself." This is no major art. This is no manifestation of particular wisdom. Quite the contrary. I will take as an example what has been done at the Institute for Metallurgy and Metals Technology. When we make a machine and want to automate a given process, we turn to the Institute for Cybernetics and Robotics. If we want to make certain special programs, naturally we must resort to the mathematicians. If there are specialists in the university, we turn to them, if the specialists are in other academies, we will seek them out there, if the specialists are outside the capital then we will find them also. Each thing is done by the one who understands it best and knows it best. Everyone is concerned with expending a minimum of energy. Ultimately this is a natural law which we must not run counter to. This weakness (I have in mind specific instances which I will not mention) is also apparent in the academy in the form of "we will do it, our institute." Even taking an idea from another institute and instead of working it out together with this institute, there is a rush to work it out independently. This is a non-academy approach and does not correspond to the spirit which must prevail in the BAN.

Another very important question is improving the efficiency of scientific labor. You know that we have signed a contract for automating a scientific experiment. In many places this has already been done but this is not sufficient. We have not supplied our individual units with sufficient equipment. How can we improve the efficiency of scientific labor? In the first place, in supplying people with suitable equipment and a physical plant. Secondly, by auxiliary personnel. Highly skilled specialists should not be concerned with things which can be performed by low-skilled persons. Thirdly, when everybody seeks the help of the person who is a better specialist in the given area, who works better and can provide advice, in order to complete the work better. We must endeavor to increase the ratio between the expenditures given for the scientific process itself, that is, the expenditures of materials, the use of equipment and so forth, and the wage fund. This ratio

in the academy is very unfavorable and this shows that we still are following the extensive path of development. But this cannot be done all at once and does not depend solely upon us. More and more barriers are being erected in front of Bulgaria and from outside they are endeavoring to create internal erosion and whatever. There have already been such instances.

In the past, we wanted to develop production methods for producing pure silicon for semiconductor equipment. We were refused because we could purchase it. We purchased it but now what if they do not provide it? We are becoming dependent and entire sectors of industry are lagging because we were not promptly concerned with solving a question which should have been solved. the creation of our own element facilities and the creation of instruments -- this means the achieving of the highest degree of independence. This is one of the major duties of the BAN. The thoughts of each scientist in our academy must be focused here.

We have technical ministries with which we work and we have contracts with them. However, to my greatest regret, I have not seen the leading bodies of these ministries come to the institutes and take an interest in what they are doing and whether this can be employed in practice. Only one institution does this. Bear in mind that often a scientist does something without even suspecting that it could be applied.

A typical example was the case of Hertz when he discovered electromagnetic waves. Asked what was the practical purpose of his discovery, he replied: "But this is a physical phenomenon and has no application at all." Can we even imagine now what life would be like without radio waves!

It is true that the time has come when people learn to quickly apply achievements. We must also apply them quickly. But many things must be sought from the consumer, from the person who feels no need to make a trip or learn what is being done at a given institute and is very necessary but we cannot realize this. There have been such instances and many of them. We must merely establish the habit of having contact between the institutes and those who are the consumers of science and we must show a greater interest in creating a diffusion link between the institutes and between them. Otherwise there will be no progress. The question is a two-way one.

In the first place, we have the obligation, the civil duty, for this we are paid, for this we exist and live, to contribute to the all-round development of our country. But in order for us to help, the level of science must also develop. In our times without a social bidding science cannot develop. Science develops where there is a high level of all life. We are a highly developed state and we must establish the direct link and feedback between the consumer who uses science and the one who must be the social investor for science so that science is always working on something and creating something new. Without this it is impossible to stimulate science.

Recently a great deal has been said about fundamental research. Certainly all the party and state documents mention that the BAN is the coordinator of fundamental research in Bulgaria. This is actually the case. But when I myself discovered something and had a clear understanding that it might be

employed somewhere, as an engineer I saw this long and difficult path to implementation. But not everyone sees it. From a theoretical physicist who has discovered something very interesting can we demand constantly that he sees its application in industry, when he does not know this industry and it is not his job to know this.

In this chain from an idea to its realization as an idea, to the realization of the product in a machine with industrial maturity, in a production method, in a material and so forth, it is essential to have links and each link respects itself and knows that it is as essential as all the others. An anchor chain cannot be held in place by one end. Each link is equally important and equally equal. We still are not accustomed to work in this manner. Recently I have observed departmental institutes which in a desire to justify their existence condemn something done in the academy, the first work, and after this take it up and represent it as their own. In our nation "intellectual robbery" has begun (to put it crudely). This should not be permitted.

We have recognized that there are a fundamental stage, an applied stage and a development stage in science. I think that Louis Pasteur would say: "There is no fundamental and applied science, there is only science and the application of science." That is better! There is science and the application of science!

Here we were concerned that very few scientists working in the area of humanitarian sciences wanted to speak. Only Prof Dokov and Corresponding Member Pirov. It seems to me, as is stated in the Holy Scripture that "the day is coming and is nigh," when precisely those sciences relating to man and human society would emerge in the forefront, and with great force because of the urgent need.

Let us not forget that the scientific and technical revolution which is underway and all that is being done by the natural, mathematical and technical sciences which is essential for raising the economy, for defense and so forth, all of this, however, is done by people with their mentality, by persons with a spiritual structure, by persons who live in a human society where there are man -- man, man -- society relations under various conditions, in labor, at rest and so forth. And when we analyze interdisciplinary problems, we must gain the habit in these studies of involving both the humanities and the social sciences. I know that this must be the case but unfortunately I do not know how to achieve this. I do not see the technology. However, we must make an effort to do this. Ultimately things rely on man. And this is exceptionally important.

Lastly I would like to mention something which was the leitmotif of our party's February Plenum. Comrade Zhivkov appealed for revolutionary thinking and action. I would not take up this question because we have examined the plenum decisions and have adopted the appropriate resolutions, but I hear certain persons who voice such ideas that everything sounds so primitive that they are frightened. Certain persons feel that revolutionary thought and revolutionary action mean the upsetting of things and the clouding of waters. But water becomes clear only when it is left in quiet. We want clear water.

If, for example, one took the Institute for Metallurgy and Metals Technology and christened it the Institute for Metallurgy and Modern Technology or Avant-Garde or Revolutionary Technology, what revolution would come about? Or if you moved people around within groups?

Here we mean the revolutionizing of human thought. It must be admitted that very often great scientists, since they know a great deal in one area, little by little get in a rut. They simply know that that is how things are. But others who do not know how things are can find a different way. Einstein said: "Science is when everyone knows that something is not the case, a fool comes along and shows that it is." Comrade Zhivkov had in mind such revolutionizing of the human thought. Escaping from the rut, escaping from the standard, escaping from the habit, escaping from the routine and allowing thought to take flight. Human thought must rush ahead, far ahead and a natural chain must be created of the human thought rushing ahead -- science, technology and then production.

10272

CSO: 2202/23

BULGARIA

PROSPECTING FOR NEW MINERAL DEPOSITS ENCOURAGED

Sofia SPISANIE NA BULGARSKATA AKADEMIYA NA NAUKITE in Bulgarian No 4, 1985  
pp 35-38

[Article by Academician Ivan Kostov: "New Trends in the Exploration and Use of Mineral Raw Materials in Bulgaria"]

[Text] In his introductory speech at the February Plenum of the BCP Central Committee, Comrade T. Zhivkov, emphatically stressed that in order to meet the growing needs of scientific and technical progress, there must be the "constant replenishment and enrichment of the energy and raw material base of production, the use of new energy sources and materials with preset properties." Material raw materials, as is known, represent the backbone of scientific and technical progress and the energy supply depends largely upon them. In contrast to plant and animal resources, mineral raw materials are "nonreplenishable" and once removed from the ground, they do not regrow. Many of the previously known rich mineral deposits have already been depleted and many of the presently known are about to be depleted. According to an overall estimate, with the present rate of the utilization of mineral resources, a utilization which is rather thrifty, by the end of our century there will be depleted supplies of the ores of lead, copper, zinc, tin, uranium, gold, silver and so forth. In addition to the known, traditional mineral raw materials scientific and technical progress is seeking to exploit new raw materials, while simultaneously seeking opportunities to broaden the supplies and the use of known mineral raw materials. These opportunities lie in two main areas: a) seeking rich concentrations of deep-lying minerals; b) employing poor, even "super-poor" mineral raw materials, in bearing in mind the employment of new production methods. Rock is "super-poor" but inexhaustible sources of metal and usable minerals. A third possibility lies in employing man-made mineral raw materials "with preset properties" on the basis of natural mineral raw materials or waste products from their processing.

Our nation has often been mentioned as poor in mineral raw materials, but in essence with its diverse and complex geological composition and structure, Bulgaria undoubtedly has rich potential possibilities. There are possibilities of finding undiscovered deposits and of using comparatively poor ones. The guarantee for this is, in the first place, the achieved scientific and technical progress and after this the already existing high skill of our

scientific personnel. The use of mineral raw materials commenced, as is known, out of utilitarian considerations, first clay and flint, followed by metals and precious stones which simultaneously satisfied the aesthetic needs of man. Later there was also a desire to understand the essence and origin of the diverse mineral raw materials as more and more of them entered into the utilitarian orbit of man. The development of our mineral raw material base came about in an analogous manner, through the cyclical linking of science with practice and with the aid of rapidly developing equipment as the connecting link.

The standard methods employed in Bulgaria for locating mineral raw materials accord well with the methods widely employed in other countries. These include comprehensive geological and mineralogical research combined with geophysical prospecting. In most instances the geophysical research involves expensive equipment but naturally without this it would be hard to "traverse" the bowels of the earth. Particularly after World War II, geological and mineralogical research made rapid progress both in Bulgaria and in other countries. This rapid progress was realized due to the developed new equipment (X-ray analysis equipment, roentgen spectographs, electron microanalyzers, high-resolution electron microscopes and a number of others) making it possible to penetrate more quickly and more profoundly into the essence of the mineral raw material, its composition, its structure and physical properties. Electronic computers and programming the research processes have already become routine, facilitating and accelerating the obtaining of objective data and decisions. These have led to new trends used in the discovery of mineral raw materials. Particularly important are those trends which are linked to the locating of mineral deposits which do not emerge on the surface and this is one of the main problems for us and throughout the world generally. Naturally it is not economic to seek unexposed mineral deposits underground merely using geophysical methods and without a geological and mineralogical premise. The geological and mineralogical premise is usually provided in two most general aspects: tectonic-stratigraphic and geochemical-mineralogical. The first aspect provides a general background and a concrete structural feature of the earth's crust against the background of which detailed geochemical and mineralogical research is conducted. The epidermal geological composition and structure of our nation both generally and locally have been comparatively well studied and for Northern Bulgaria there are even some volumetric parameters. However, the complexity of the geological structure poses still unsolved questions particularly in areas which would be most favorable for locating covered mineral deposits. These are some of the strongly folded and strongly fractured areas of the Balkan Range, the Sredna Gora Mountains and Strandzha and the Rhodopia Area. There still are contradictory opinions on the geology of these areas and until more uniform generalizations are received about them, it would be difficult to give estimates on the possibility of finding commercial mineralizations.

The geochemical and mineralogical aspect can be the most essential one in locating covered ore bodies, particularly in terms of the hydrothermal ore deposits (lead-zinc, copper, copper-molybdenum and so forth) which abound in our nation. Linked to many of these deposits and this type of mineralization processes are a number of other usable mineral raw materials which are also

widely present in our nation (for example, zeolite rock, clays, alunites, monoquartzites and so forth). The geochemical and mineralogical prospecting usually involves the establishing of the halos of changes in the chemical and mineral composition of the rock which covers beneath one or another concentration of usable minerals. This type of research involves our presently employed hydrogeochemical research of thermal waters. The latter undoubtedly are the best natural "testers," since in their deep circulation they extract from the corresponding rock and from the concealed ore bodies various chemical elements which are indicators of the composition of this rock and ores. The outlines of the haloes of mercury, selenium, tellurium, bismuth, thallium and other elements marked by a strong migration ability can be employed and is employed successfully for locating deep-lying mineral deposits. Similarly it is possible to employ biogeochemical methods which presently are of particular importance in line with natural conservation.

Determining the halos with appropriate changes in the overall chemistry and in the mineral composition of the rock as an indicator of the location of a deep mineral deposit is expressed in a certain zonality which, in accord with the employed indicator element, can be chemical (in terms of the quantitative change in the content of the given elements), mineralogical (according to the change in the development of the corresponding minerals), morphological (according to the change of the appropriate crystal forms of the given or associated minerals due to changes in the crystallization conditions) or structural related to fine changes in the real structure of the given mineral. An indicative example in this regard is the group of chlorite minerals which are successfully employed in the USSR in locating polymetallic ores and which is also employed for locating such and analogous ores in Bulgaria. In this instance chemical-structural zonality is employed, that is, the change in the chemistry of those magnesium-iron hydrosilicates linked with the isomorphic (structural) replacement of magnesium by more iron and particularly zinc, and in addition to this to the fine structural (polytypic) change. The establishing of halos (zones) with a varying content of zinc and iron and the appropriate chlorite polytypes ensures a sound forecast of the presence of polymetallic ores down deep. Here the composition of the chlorite minerals is easily determined using rapid roentgenometric methods. Also in this area but still unused are the possibilities offered by a number of other physical methods, for example, resonance methods. Electron paramagnetic resonance (EPR method) uses the establishing of fine structural defects in the given mineral which depend upon the conditions under which it crystallized and under which it can undergo changes. By the statistical processing of such defects it would be possible to establish the halos hinting of increased concentrations of one or another element or of a process related to the mobilizing of the chemical elements. The EPR method, along with standardized methods used for this type of deposit, is already being employed in locating uranium deposits.

In contrast to the period prior to World War II, at present we have introduced a significant number of new mineral raw materials and new applications have been found for many of these. Zeolite rock is an example in this regard. Previously zeolite minerals were employed almost exclusively as softeners of hard water. Now it would be hard to list the numerous areas where these valuable minerals have been introduced and the opportunities for their even wider application are not exhausted. In principle each mineral can be

utilized provided it is well studied. Around one-quarter of the nearly 3,000 presently known minerals have been found in Bulgaria. A large number of these has usable concentrations and for many of the remainder one can assume the presence of concentrations for such a premise. Naturally, as on a world scale, the trend is to utilizing the poor-composition mineral deposits, in applying improved or new methods for extracting the corresponding metals or useful components. The future points to the use of various types of rock which include more or less all the chemical elements of the Mendeleev table. The problem is to extract these economically, as did the circulating waters in the ancient history of the earth's crust. However, our problem is a technological one. In this area, it appears, the gates are already open and one possibility involves the biogeotechnological processing of metal-containing ores and concentrates. The use of bacteria in hydrometallurgy is a known process and here the process is economic, occurring at a normal pressure and customary temperatures (between 5 and 80o C). Chemolithotrophic bacteria are widely represented in ore deposits and ore tails, in thermal waters and elsewhere, in oxidizing the sulfide minerals from them according to the laws of electrochemical corrosion. By heterotrophic organisms it is possible to extract from the rock such elements as titanium, manganese, nickel, gold, uranium, aluminum, silica, cobalt, cadmium, arsenic and others. It is also possible to achieve selective extraction in the aim of enriching one element at the expense of the other, for example, to extract potassium from feldspar-like or feldspar minerals in the aim of enriching them for aluminum. The bacteria accelerate the decomposition of even such minerals as quartz, and to a significant degree. Obviously, this is a highly promising and high economic area of research on the possibilities of breaking down rock-forming minerals and extracting from them the valuable chemical elements through the heterotrophic and hemolithotrophic microorganisms. This also involves the processing of the waste products obtained as a result of using the natural mineral raw materials.

Along with natural mineral raw materials, scientific and technical progress more and more relies on artificially produced mineral products. In first place in this area are the artificial crystals which are the heart of electronics. In this regard Bulgaria is still lagging behind although firm steps have been taken to overcome this backwardness and there are already good results. Natural minerals provide us with magnificent models of crystals which are or can be turned by appropriate modifying into a valuable raw material for electronics. Well known in this regard are the ferroelectric crystals which have new valuable phenomena such as a background echo (electropulse acoustic oscillations with backwaves, echo signals which appear in certain instances after a month by memory), ferromagnetism and so forth. The ferromagnets, in essence, are new substances with magnetic and ferroelectric arrangement in their structure causing valuable properties. The ferroelectric crystals along with the piezoelectric and gyrotropic crystals are linked with non-centrosymmetry in their crystalline structure. But the centrosymmetric crystals are also important. Fluorite which is now synthesized in Bulgaria is a centrosymmetric crystal but its optical properties are those which make it a valuable artificial product. Fluorite raw material is exported primarily as a smelting agent for metallurgy and here without any great economic effect, while the optical qualities of this mineral make it more valuable in this area where not tons of fluorite ore are needed

but rather grams of high-grade crystal. We already have the prerequisites for the development of man-made mineral raw materials with the establishing of the Institute for Applied Mineralogy under the Bulgarian Academy of Sciences. Its approved interdisciplinary program has been initiated in a broad range for three main areas emphasized above: better research on natural mineral raw materials in Bulgaria with the aim of disclosing their finest properties which make them suitable or unsuitable for industry, the complete utilization of plant waste products and the obtaining of monocrystals with useful properties for various industries. With the presence of modern equipment, the finding of the optimum technologies for obtaining positive results in the three areas shows promise for us, in bearing in mind the established integration of the various scientific research units within the Bulgarian Academy of Sciences and outside it.

10272

CSO: 2202/23

CZECHOSLOVAKIA

CSSR JSEP COMPUTER EC 1027 DESCRIBED

Prague MECHANIZACE AUTOMATIZACE ADMINISTRATIVY in Czech No 3, 1985 pp 82-84

[Article by Eng Zdenek Korvas, CSc: "The Czechoslovak JSEP EC 1027 Computer"]

[Text] The JSEP series of computers in Czechoslovakia has been expanded by a new model manufactured in Czechoslovakia, the EC 1027, developed at the VUMS (Mathematical Machines Research Institute) regional center. This type of computer is designed for demanding tasks of data processing and scientific and technical computation.

In conformity with current world developments, whenever increasing demands are being placed on efficiency, the overall efficiency of the computer has been increased significantly in comparison with the previous model (the EC 1026). To increase overall efficiency it was necessary to increase the nominal efficiency of the processor and to correspondingly increase the capacity of the main and external memories.

The operating code of the computer is compatible with that of previous JSEP computers so that the already existing extensive library of user software can be used in full. In accordance with the code of the new series, the JSEP contains a code for several new instruction meant primarily for speeding up the operating system. In order to further increase efficiency, there are plans for transferring several functions from the operating system to microprograms or for creating so-called assists.

In order to accelerate the development and facilitate the production of computers it was decided that the EC 1027 would be based as closely as possible on the EC 1025 and 1026. The overall structure of this computer derives from a proven multimodular sectional structure, and basically retains the same intermolecular contact and internal structure of transmission modules designed for the attachment of peripheral devices. There is an entirely new design of the operations processor, the organization module, and the main memory. The disk module for direct attachment of disk memories has an expanded capacity for attachment of 8 spindles of 100 or 200 MB disk memories, and has a faster contact with the main memory than the EC 1026.

The transmission modules include, in place of a syllabic multiplex module, a new module with two channels: a syllable multiplex module for slow devices

and a block multiplex module for the external memory and other fast devices (with a speed of up to 1.5 MB/s). In addition, one can plug in a second disk module for demanding applications. The communications module can provide a rapid port (without a modem) for the attachment of near terminals or for connecting computers into the system.

The EC 1027 has a similar design to the previous JSEP computers. The lower levels of design (disk, block) are not greatly changed, while the double computer screen (base 1.45 x 0.7 m<sup>2</sup>, height 1 m) and the operator desk are designed anew.

#### Computer Structure

The basic unit of the EC 1027 consists of the following blocks (see Figure 1):

- operations processor (OP),
- organizer (ORG),
- main memory (HP),
- service module (SRM),
- disk module (DSK), one or two,
- two-channel module (DKM) or multiplex module (MPX),
- communications module (KOM),
- tape module (PSK).

The operations processor uses a 32-bit data flow width, has its own operating block for preparing instructions and uses a rapidly equilibrating (so-called "cache") memory, of 80 KB capacity. (An article on this memory will appear in the next issue). The equilibrating memory uses block transmission of data from the main memory, with a 32 B block length. The processor cycle is 250 nanoseconds. The main memory has a 2 MB capacity and uses the 160 kilobyte Czechoslovak MOS dynamic memory circuit. The element basis of the operations processor and the remaining newly proposed modules consists primarily of Czechoslovak TTL circuits, of medium, or sometimes of large integration.

A special bus for data transmission from the HP to the OP (see Figure 1) has an 8-syllable flow width and makes possible rapid transmission of a 32-syllable block from the HP data register to the OP equilibrating memory (cache). A more detailed description of the structure of the basic unit and the individual modules of the computer is given in the literature (1).

The nominal efficiency of the EC 1027 for five instruction mixes is compared with that for the EC 1026 in Table 1.

#### Peripheral Devices

Decisive for the overall efficiency of a computer, from the viewpoint of hardware, are not only the processor and main memory but also the peripheral devices, in particular the external memory and the terminal attachments.

The principle of attaching external memories in the EC 1027 is based on the earlier EC 1026: the basic unit is made up of two independent modules, the

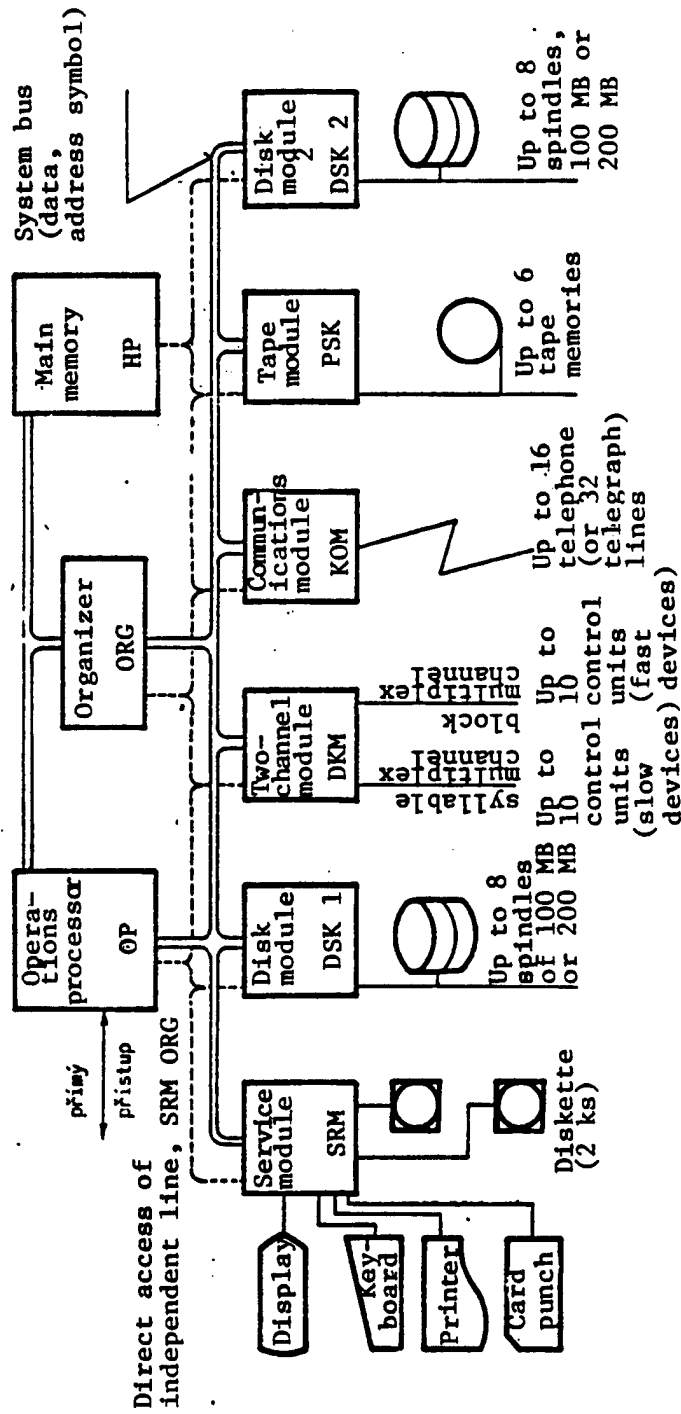

Figure 1. Structure of Basic Unit of EC 1027 Computer

disk (DSK) and tape (PSK) modules, which combine the functions of channels and control units. This solution is advantageous both from the technical viewpoint, in that central control, feeding and diagnostics are possible, but also from an economic viewpoint. The disk modules are designed for 100 and 200 MB disks, which are now being produced in the CSSR. The maximum capacity of the external disk memories operating with one disk module is 800 MB or 1600 MB.

If needed, a second disk module can be built into the computer housing and other external memories can, if so desired, be connected to the standard block-multiplex channel of the two-channel module. In this case, however, the appropriate disk memory control unit must be added to the computer. The transmission speed and parameters of the block-multiplex channel allow for attachment of both a progressive disk memory with 317-635 MB unchangeable disks or a standing external memory with a control unit (for example 29 MB). The tape memory is attached via the appropriate module (up to 6 EC 5004 tapes) or via the block-multiplex channel of the two-channel module.

The main device for attaching the participating stations is the communications module, which contains up to 16 lines for synchronized transmission (BSC) or 32 lines for start-stop transmission or a combination of the two (2 start-stop lines for 1 synchronous). It operates both on leased lines (point-point or multipoint) and on commutated lines (point-point). The start-stop links use either a teletype interface or an IRPS interface for attaching asynchronous terminals (for example the SM 7202 display). The communications module is equipped with devices for automatic selection in either a telephone or a teletype network.

The console peripheral devices (a monitor, keyboard, printer, two disk drives or a tape punch) are served by the service module. During normal operations this device serves for the operator; during repairs it is intended for technical servicing. The service module contains extensive software for the following function: initial startup of computer, monitoring activity, operational operator service, service of outpour-order states including report of disturbance, diagnostics, and devices for interference/intervention into the microprograms. A review of the most important peripheral devices and terminals forming the basis of the computer configuration is given in Table 2. Other devices can be attached according to the individual requirement of a given installation. The column "method of attachment" briefly lists the appropriate modules of the basic unit of the computer for Figure 1.

#### Multicomputer Systems

The EC 1027 can be used to form multicomputer systems with the following types of attachments:

- a) Through the communications module. For speed it is best to use metallic lines (at shorter distances of up to about 1 km), a method which can be used to connect the EC 1027 with similar and different computers and with terminals (EC 1026, EC 8540=Aritma KA 10, IT 20, ADT 4500, SM 4);

Table 1. Nominal Efficiency of Computers (thousand instructions/sec)

Computer	COMPUTER	GPO	GIBSON 1	GIBSON 2E	GIBSON 3D
EC 1026	100.0	75.3	54.0	76.9	49.0
EC 1027	477.3	307.2	235.9	469.7	213.8

Table 2. Survey of Most Important Peripheral Devices

Designation	Name	Method of Attachment	Speed	Medium capacity	Average number	Remarks
1. EC 5066	Disk memory	DSK	806 KB/sec	100 MB	8 + 16	USSR
2. EC 5067	Disk memory	DSK	806 KB/sec	2 x 100 MB	(one of these types)	BLR
3. EC 5080	Disk memory	DSK	806 KB/sec	200 MB		
4. EC 5004	Magnetic tape memory	PSK	126 KB/sec		4 + 6	Reservoir
5. EC 5075	Input and output	MPX or DKM	30 KB/sec	240 KB	1 + 2	20 diskettes
6. EC 7039	Line printer (string)	MPX or DKM	1200 lines/min		3	{Variable chain up to 480 symbols
7. EC 6112	Table-top card reader	SRM	300 punches/min		1	
8. EC 7920	Display subsystem:					
EC 7925	Independent display with data transmission with possibility for attaching dot-matrix printer EC 7934	KOM	up to 9600 b/sec print 80 symbols/sec	1920 symbols on screen	10 + 20	
or EC 7921	Control unit with data transmission with possibility of attaching up to 32 EC 7927 displays or EC 7934 dot-matrix printers	KOM	print 80 symbols/sec up to 2400 b/sec	1920 symbols on screen	0 + 3	USSR
or EC 7922	Control unit with attachment to a channel, with possibility of attaching up to 32 EC 7927 displays or EC 7934 dot-matrix printers	MPX or DKM	print 80 symbols/sec	1920 symbols on screen	1	USSR
9. EC 8591	Five-element teletype	KOM	50 b/sec		5 + 10	
10. EC 8593	Five- and seven-element electronic teletype	KOM	50 + 200 b/sec			
11. EC 8576	Terminal--el. type-writer (synchronous data transmission)	KOM	1200 + 2400 b/sec print up to 150 symbols/sec			about 5 as required
12. SM 7202	Display with start-stop data transmission (not safeguarded)	KOM		1920 symbols on screen		as required

b) Direct attachment via a channel/channel adapter is suitable for creating a complex of two EC 1027d, the channel/channel adapter being a part of the DKM two-channel module.

Attachment of the computers is suitable for increasing the overall accessibility of a system, particularly for realtime operation with large demands for providing uninterrupted activity, and creating a system of minicomputers connected to a central computer.

#### BIBLIOGRAPHY

1. AKTUALITY VYPOCETNI TEHNIKY, No 46, 1983.

9832/9365

CSO: 2402/14

CZECHOSLOVAKIA

#### SMEP IN MASS DATA PROCESSING DISCUSSED

Prague MECHANIZACE AUTOMATIZACE ADMINISTRATIVY in Czech No 3, 1985 pp 101-104

[Article by Jana Folprechtova, graduate mathematician, and Eng Jiri Malina, Kancelarske Stroje, k.u.o. [expansion unknown]: "SMEP Computers and Mass Data Processing"]

[Text] It is satisfying to view the recent accelerated introduction of computer technology based on minicomputers, a technology which, thanks to the SMEP program, is becoming increasingly more available to users. An analysis of the intentions of participants in the training course organized by the educational division of Kancelarske Stroje Prague, k.u.o., shows that 60-70 percent of the enterprises sending their workers to this course anticipate that minicomputers will come to be used for mass data processing. In the authors' opinion there are two reasons for this:

--the TESLA and EC 1021 series of computers, used up to now for mass data processing, are currently being retired, which results in a relative shortage of such computers for updating all presently operating computing centers;

--the SMEP system is relatively inexpensive and simple to install in preexisting areas of computing centers and in addition it has gained great popularity through a number of countrywide publicity campaigns.

In this article we will discuss several areas of application of SMEP computers, not yet widely known, particularly the area of mass data processing. There are two conflicting attitudes toward such use:

1. Exaggerated expectations of the omnipotence of this system. The parameters given, for example the size of the operating memory and the operating speed, are least comparable with the EC 1021, for example, and at first glance it seems that this solves the problem of updating this technology.
2. The SMEP system is viewed as something small or mini, and plans are to use it only for data preparation or preprocessing for a larger computer.

The truth lies somewhere in the middle. The SMEP system cannot replace a medium-sized computer under the operating conditions now prevailing in computing centers, i.e. under batch processing conditions, such that on the one

hand we have a completed list of requirements and a completed entry data form, and on the other hand a stack of printed paper. The use of this type of computer only for the collection and preparation of data is, in contrast, a degradation of a system capable of performing significantly more work.

## 1. Operating System

The SMEP minicomputers are and will be produced primarily in the versions SM 4 and SM 52/11, manufactured in the CSSR, USSR, or other CEMA countries. The technical differences between these systems are insignificant as concerns software, thanks to cooperation between government agencies. Several operating systems have been designed for these computers, the most widely used of which will evidently be the DOS-RV2 and improved versions of it.

We come to this conclusion from an analysis of similar systems abroad, in that the DIGITAL firm's best-selling systems contain the similar RSX-11M operating system.

The following paragraphs will deal with the DOS-RV2 operating system.

### 1.1 Characteristics of the DOS-RV2 Operating System

This operating system is a real-time disk-oriented system. By disk-oriented, we mean that the operating system and all auxiliary programs are transferred from disk to memory and all products of the system are put on diskette, i.e., source-form programs, translated programs, and compiled programs. Input and output data for the program in question are also put on diskette. A program is run in such a way that, at the operator's request, in running form, it is transferred from disk to memory and started. The basic properties of this system are:

--the system can run several programs at one time, by one or several users;

--the system dynamically controls the memory, and SM 4 computers are 16-bit, addressed to a byte, and a program can be only 64 kilobytes in size; the hardware, however, has a so-called memory control unit, which makes it possible to put a running program into any part of the memory (the operating memory is 248 kilobytes), and thus to put several programs in it, with dynamic change in their location if desired;

--the system is controlled by the occurrence of so-called significant, events, among which is, for example, completion of v/v operation, at which point, inter alia, requests for running programs, are reviewed and, by a priority system for assigning memory to the appropriate tasks, programs are shifted within the memory in such a way that the maximum number are accommodated and one is assigned to the processor;

--the system can have several sectors of shared memory for several programs, and shared data relevant to several programs, or reentry programs used by several programs at once, may be located in these sectors as a way to compensate for the shortage caused by the 16-byte address memory;

--there may be more requests for running programs than there is memory space, but by shifting completed programs to disk it may be arranged that the system will operate even in this case, and that no request for running a program will be rejected; the number of requests for running programs is limited only by the size of the system's dynamic memory (pool), although, of course, there is an increase in the time required for system overhead; experience has shown that the system can be loaded with up to 10 programs without any significant problems;

--the system can be used to create a program system of independent programs which can transfer data to each other via the system dynamic memory, or can call each other;

--one component of the system is an efficient compiler program, which among other things makes possible any amount of tree segmentation of programs;

--the operating system contains a built-in efficient system for protecting data and programs from unauthorized access, so that each user operates as if he were independent, with the right to use only those sources of the system assigned to him, his own programs and his own data, while only so-called privileged users have access rights to all system sources and all user areas, with the right, for example, to break up sets (of data?).

The DOS-RV2 operating system is supplemented by several system programs which are used in particular for writing programs in the edit--translate--compile--run cycle. The compiler program operates with modules which must be written consistently from all translators used, so that if one observes a few simple rules, one can combine parts of programs written in different languages.

Auxiliary devices include a highly efficient program for processing indirect sets of commands, which, using a special language, can process a prepared set [of commands] for the control of often repeating work, for example, for an already changed program tuning cycle. This language allows for branching, for the input of a string of symbols and values from terminals, and for the writing and running of lower-level sets [of commands]. The program was developed by the system's authors in particular for its generation, but it is freely available to any user.

## 1.2 Translators

The operating system can be used with several translators of various levels. The best developed appears to be Macroassembler, a knowledge of which is essential for a systems operator. Those operators switching to the SMEP from the JSEP systems will be struck at first use by its obvious great differences; although it lacks certain associated instruction of the JSEP assembler, its efficiency seems to be higher.

Other translators are for BASIC. Although this language is essentially unsuited for mass data processing, it can be used to process all admissible types of sets [of commands], and several computing centers have written an

agenda processing programs in this language for the earlier generation of SM 3 computers. An advanced version of this translator can translate a processed program from interpreting mode to ordinary program mode, and its slowness of interpretation is also overcome in this way.

The most widely used translators in the DOS-RV2 system are FORTRAN translators. There is a long developmental series of these, they are reliable, and they can be used with all types of [command] sets accepted by the system. A long-range translator, i.e., FORTRAN 77, also has string operations and the command IF-THEN-ELSE.

It is the least used, however, in the area of mass data processing programs, perhaps because the programmers in this area have a significant degree of resistance to it. It is often repeated as an argument that the output tabulations are harder to program than for example in COBOL, but one can judge from the number of programs for scientific and technical computations that the command FORMAT can be used to control rather complex output tabulations.

The COBOL translator is used with several already operating systems. Thanks to the unfortunate orientation of the language to alphanumeric strings, which by their very nature are difficult to process on SMEP type computers, both the translation and execution of the program are very time-demanding. Experience shows that the same programs progressed in FORTRAN and COBOL take up about 50 percent less disk space [in FORTRAN], and translation is about three times as fast when using FORTRAN. Nevertheless, the translator is indispensable for mass data processing centers. It has been shown in practice that transfer of a source text in COBOL from a JSEP computer to an SMEP computer can be done fairly rapidly, and several centers have written an automatic transfer program for this purpose.

There are several PASCAL translators in the CSSR for SMEP computers. These translators have been developed not by companies but by users, and are at present still in the experimental stage. They are not yet being marketed and for the time being we know of no center where this language is being used for standard operation. The situation is still more complex with regard to ADA, in that at the time we were writing this article, a theoretical analysis was underway, but a practical solution is still nowhere within our reach.

In connection with this, we must draw attention to the DIAMS operating system, with language MUMPS, which is not a part of the DOS-RV2 operating system. This system is designed especially for processing mass data on database systems, appears to be highly efficient, but has a basic defect, in that one must start working "with a clean slate." Nonetheless, we recommend to future users that they investigate the possibility of using this language and attempt to use it in any new projects.

### 1.3 Mass Data Processing Equipment

The basic types of sets used by the DOS-RV2 operating system are a sequential set with a variable sentence length and a set with direct access and fixed

sentence length. These sets can be processed using the FCS system, which is provided along with the operating system. Users of mass data processing equipment also have available the RSZ system, which expands the use of sets to so-called relative and index sets with one or more keys. In addition to library programs, which are the proper contents of the RSZ system, certain other programs are provided along with this system; these have a more general significance, such as programs for the storage and restoration of matrix sets, etc.

There is a program SORT for classifying sets, which can be used both in the conversational mode and as a supplement to the COBOL translator. The program can classify all types of sets mentioned above, but it is somewhat more demanding of disk space, and is thus used most efficiently with large-capacity disks.

Another system for independent use is the DTS system. This system, based on a built-in matrix set, can, in conversational mode, analyze and classify items specified by a key or if desired through logical relations among the items. The sentences may be put into auxiliary sets, or classified, printed in a specified order, or used as matrix sentences for further analysis. The program is independent and its operation cannot be controlled by other programs. It is suitable for various types of records with an interactive approach, for example for personnel records, warehouse management, etc. It is somewhat laborious to form matrix sets, but several programs are near completion which deal with the establishment of a matrix set, for example, from punched cards or from an already provided magnetic tape.

In late 1983, the federal task VARS was successfully defended; it contains individual subsystems for processing the most commonly used agendas. The project derives from the similar project MARS (VARS) for the JSEP, and its individual parts are designed (up to two) for the DOS-RV2 operating system. At the time of writing this article, it is still too early to judge the usefulness of the individual programs of this system, but the reception given it by potential users indicates that it will be widely adopted.

The parametric system GOLEM V.4.1 can be used for the preparation and pre-processing of data under the DOS-RV2 operating system. This system can be used to record (write), test, examine and update data. With regard to pre-processing of data, one can connect batches on disk, magnetic tape, or punch cards, and these resulting batches can be put on magnetic tape in structure, using the JSEP operating system. A batch created under the JSEP operating system can also be used for the GOLEM system. At a number of centers this is considered to be the basic system.

## 2. Evaluating the DOS-RV2 Operating System

As can be seen from the preceding, the DOS-RV2 system was not intended for the support of mass data processing. Despite this, it is so universal that such processing is possible under it. One cannot, of course, subordinate this operating system to the established type of operation of computing centers,

but nevertheless one must, sometimes rather fundamentally, adapt the processing method of the center to this operating system. Its features can be summarized as follows:

--it is inefficient to use the hitherto customary batch processing method for large amounts of data; this method is, to be sure, possible, but it results in a substantial decrease in system use, and in a major change in the operation of the computing center;

--it also follows from the above that it is inefficient to operate with the system unless it can run at least three programs at once; the system mode is roughly the same whether we run one or three programs at once, and the processor use rises by about 25 percent;

--it is inefficient to enter a program to a prepared form, but it is advantageous to enter it by conversation directly with a terminal keyboard, and this means that there must be user access to a terminal;

--the operating system must always be under control, and because of the multiuser and multiprogram approach of the system, its operation cannot be planned precisely in advance, and it is clear that moments of relative inactivity will alternate with moments of near overload; despite all the safeguards built into the system, one must sometimes have qualified personnel step in and make it possible for all the users to receive the fastest possible response to their justified requests;

--in designing programs for this system one must follow given rules of writing, translation and compilation; these rules change over time both as information is gathered during operation of the system and by the establishment of memory-resident subprograms, which will in the long run be done by all centers desiring to operate efficiently;

--one must reckon with the fact that there will be gradual changes in the overall configuration of the computer, particularly with regard to the addition of new peripheral devices, and that the system software will likewise change and be supplemented;

--there are problems in accounting for machine time; at present there exists no method of solving this issue; besides, the cost of a machine hour is so low (Kcs 400-800, depending on configuration), that a user will generally not object to being charged for all the time spent at the terminal; there are greater difficulties in the case of using a computer network, where this problem will be solved by a lump sum payment; some centers have developed a program accounting system which takes into account processor time used and cost for use of peripheral devices (for example cost of paper used by the printer); this is at present only being used for records and not to account for machine time;

--installation of the system must go hand-in-hand with user training courses, Kancelarske Stroje, k.u.o., offers several courses, which, of course, cannot

affect the specific use of the system at the center in question; training at a center must have two aims, to prepare new users for unsupervised work at the terminal and to acquaint all users with the development of the system hardware and software.

### 3. Organization of Computing Center Operation

The style of operation of a computing center must, then, be adapted to the operating system being used, such adaptation affecting all areas of activity. This involves mainly changes in programming. If programs used by this system are to run efficiently, they must be converted from batch mode to conversational mode. The user must get used to the fact that data are almost immediately accessible at the terminal, and that the creation of groups which one might leaf through if needed is advantageous only in the case of agendas which directly require a permanent record (such as paychecks, accounting records, etc.). In all other cases the user should have all required data available in real time, and the extent of these data is specified by the need for on-the-spot decisionmaking.

The DTS system is highly suitable for on-the-spot decisionmaking. We consider that the first thing to be done after starting operation with an SMEP system is to transfer all possible agendas requiring efficient operation to this system. After gaining experience in using systems of this design, one can proceed to developing programs for systems in which DTS cannot have much effect, such as the already mentioned program for printing up paychecks.

As an example, we will try to outline a way to use the system for keeping records of supplies. We assume that a terminal will be installed at each place of issue, where a running record will be kept of the issue of the material concerned; there will be another terminal at the place where the receipt of this material is recorded, and still another terminal where current information on stores in the warehouse must be obtained. Display [screens] at the place of receipt and issue of the material will create a matrix set of data on the material, for example, for the DTS, while the display for obtaining current information will, for example, be in a department of the distribution system. In addition to basic records, the operator in question can obtain a summary of supplies at a limit state, of supplies which are barely moving, of the removal of workers in the warehouse, and of critical periods when there is the greatest movement in the warehouse. One can process daily, weekly, and other summaries of material oriented primarily toward material in movement. This can all be accomplished without printing up complete lists and without the time delay which occurs when these data are updated by an issue- and punch-program system. The advantages of using this system are obvious.

When using a system for warehouse records other programs can be run on the computer at the same time, such as personnel records while still other programs can be "tuned" during the same time.

This example demonstrates that certain activities must be distributed. This concerns primarily operator activity, when the user becomes his or her own operator. Two things are needed for this, a terminal as close as possible to

the workplace and the knowledge needed to use the terminal efficiently. The level of knowledge needed depends on how good the available software--the better the software, the less understanding required.

In contrast, there are a number of activities which must be concentrated. It can be seen from the above examples that the concept of an operator, as used in the batch processing mode, is not relevant here. Instead of an operator there must be an individual capable of monitoring the entire operation of the system, with a high level of knowledge and authority over the users, since, in the interests of operating the system as a whole, there are certain times when he or she must slow down the work of some user. The DOS-RV2 operating system has sufficient system programs for this activity, ranging from the simplest to pseudographic monitoring of the state of the system on a display screen. In addition to this activity, the system operator is in charge of changing the beams on the magnetic media, monitoring the operation of the printer, which is generally not directly accessible to the users, starting and stopping system operation, and restarting it in case of system shutdown.

Thus the systems operator is no longer a worker who services only the peripheral devices but the master of the system while it is operating. He or she must be capable of an instantaneous and trained reaction to the state of the system under conditions of stress. Certain tasks must be done by someone else. The actual user has his or her rights limited to such an extent that he or she cannot disrupt the operation of the system or the work of another user. The systems operator is always privileged because of his or her knowledge, but this privilege bears with it a high degree of responsibility. It is always worthwhile to have such an operator; it may be stated that if he or she works responsibly the accessibility of the system may be increased by as much as 30 percent.

In addition to a systems operator, who must be present at the system for the whole time that it is operating, there is also the systems manager, whose job description is new. It consists primarily in developing and maintaining the system; this manager must also act as consultant in the use or writing of new programs. He or she must be responsible for training users, and has the ultimate responsibility for solving conflict situations between the users and the systems operator. An integral part of his or her work is analysis, together with the technical group, of every system breakdown. He or she must suggest or even take measures to assure that similar breakdowns will not occur in the future.

One of the most thankless activities is distributing magnetic media to the users, since there are never enough of these media. Of course, the systems manager must also keep track of what new offerings are available from the supplier or what can be purchased from other computing centers. He or she must have an advanced knowledge of programming in macroassembler, and must be able to program and start several of the more commonly used modules. Experience shows that the quality of the manager's work affects the activity of the center as a whole, and if it is good, then his or her departure, without a good replacement will have negative consequences.

There is also an ever increasing demand for qualified technical personnel. The maintenance of an extensive system in operating condition requires, in addition to an adequate supply of spare parts and systems, a good knowledge of modern technology of the 3.5 generation (?). Technical personnel are responsible not only for repairing defects but also for preventing them. The DOS-RV2 has a system for monitoring hardware trouble which does not result in breakdowns, and a system for testing peripheral devices, which can operate under the operating system without disrupting its operation.

We must constantly bear in mind that a breakdown of a system in batch mode means that a given program must be repeated, which is, of course, unpleasant but not impossible. For a multiuser system a breakdown sometimes involves irreparable losses, which are very difficult to remedy. This is why such emphasis is placed on preventive work of the technical personnel, and why it is better not to start up a multiuser system until one is sure that it will be operating very reliably. This concerns in particular the use of systems for the control of engineering processes, but even when such a system is used for mass data processing in the conversational model, losses due to system disruption are by no means negligible.

The transition from a single-user batch process system to a conversational multiuser system is full of problems. It is especially important to point this out to those in control of workers, who expect highly specific results immediately after installation of the system. Experience shows that efficient use of the system is a gradual process, and that the first good results cannot be expected in less than 6 months after the system has started operating. It is recommended that when an SMEP system is first installed the preceding system be retained for some time. Impatience and a push for the immediate installation of a system usually leads to the development of "demonstration" programs, which can be highly efficient but take time away from actual operation.

We also recommend, before installing a system, that those involved attend all available courses and if possible send their basic workers for further training to an enterprise where a similarly designed center is already set up. By no means can the primary workers' training be viewed as something of secondary importance, while their primary work experience is work on another computer system.

#### Conclusion

In conclusion it may be stated that although the DOS-RV2 operating system is not unambiguously designed to support a data processing system, it can also be used for this purpose. Its main advantage is that it is a living system, used by many users here and abroad, while its wealth of tested programs has as yet been little used by us. Preparations are underway for updating it in the near future, while retaining the capability for transferring programs from a lower-level system to a more modern system; it is expected that it will be usable even with prepared computers having up to 32 bits of addressing.

Despite these undisputed advantages, the installation of such computer systems brings with it many problems related to the overall utilization of computer technology for mass data processing, which are still with us from the period of second-generation computers. The introduction of these systems will be resolved by a change in attitude especially on the part of the users, together with the installation of computer technology where it is most needed, in the area of on-the-spot control.

9832/9365  
CSO: 2402/14

END