

045046

JPRS-ESA-85-037

20 December 1985

East Europe Report

SCIENCE AND TECHNOLOGY

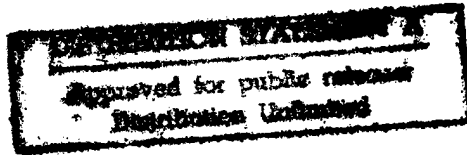

19981022 088

DTIC QUALITY INSPECTED 4

FBIS FOREIGN BROADCAST INFORMATION SERVICE

REPRODUCED BY
NATIONAL TECHNICAL
INFORMATION SERVICE
U.S. DEPARTMENT OF COMMERCE
SPRINGFIELD, VA. 22161

2
79
A05

NOTE

JPRS publications contain information primarily from foreign newspapers, periodicals and books, but also from news agency transmissions and broadcasts. Materials from foreign-language sources are translated; those from English-language sources are transcribed or reprinted, with the original phrasing and other characteristics retained.

Headlines, editorial reports, and material enclosed in brackets [] are supplied by JPRS. Processing indicators such as [Text] or [Excerpt] in the first line of each item, or following the last line of a brief, indicate how the original information was processed. Where no processing indicator is given, the information was summarized or extracted.

Unfamiliar names rendered phonetically or transliterated are enclosed in parentheses. Words or names preceded by a question mark and enclosed in parentheses were not clear in the original but have been supplied as appropriate in context. Other unattributed parenthetical notes within the body of an item originate with the source. Times within items are as given by source.

The contents of this publication in no way represent the policies, views or attitudes of the U.S. Government.

PROCUREMENT OF PUBLICATIONS

JPRS publications may be ordered from the National Technical Information Service, Springfield, Virginia 22161. In ordering, it is recommended that the JPRS number, title, date and author, if applicable, of publication be cited.

Current JPRS publications are announced in Government Reports Announcements issued semi-monthly by the National Technical Information Service, and are listed in the Monthly Catalog of U.S. Government Publications issued by the Superintendent of Documents, U.S. Government Printing Office, Washington, D.C. 20402.

Correspondence pertaining to matters other than procurement may be addressed to Joint Publications Research Service, 1000 North Glebe Road, Arlington, Virginia 22201.

NOTICE

Effective 1 January 1986, JPRS will combine all material on East Europe in a new report, entitled EAST EUROPE REPORT, with the trigraph EER. Contained in the new report will be all material previously published in the following three JPRS reports, which will be discontinued:

EAST EUROPE REPORT: ECONOMIC AND INDUSTRIAL AFFAIRS
EAST EUROPE REPORT: POLITICAL, SOCIOLOGICAL, AND MILITARY AFFAIRS
EAST EUROPE REPORT: SCIENCE AND TECHNOLOGY

Subscribers who received any of these three reports prior to 1 January 1986 will automatically receive the new EAST EUROPE REPORT.

To change their subscription, U.S. Government subscribers should notify their distribution contact point. Non-government subscribers should contact the National Technical Information Service, 5285 Port Royal Road, Springfield, Virginia 22161.

20 December 1985

EAST EUROPE REPORT

SCIENCE AND TECHNOLOGY

CONTENTS

CZECHOSLOVAKIA

- Problems With Getting, Keeping Qualified Physicians Discussed
(RUDE PRAVO, 19 Jun 85) 1

GERMAN DEMOCRATIC REPUBLIC

- GDR Research Databank Construction, Applications Reviewed
(Dietmar Keil; INFORMATIK, No 4, 1985) 4

POLAND

- New Engineering Products Advertised
(POLISH ENGINEERING, No 3, 1985) 7
- New Process for Making Radiation Treated, Heat-Shrinkable PE Tubes
(WIADOMOSCI ELEKTROTECHNICZNE, Nos 7-8, 1-15 Apr 85) 13

ROMANIA

- Synthesis of Tricyclic Antidepressive Drugs
(Dorin Brezeanu, et al.; REVISTA DE CHIMIE, No 7, Jul 85). 19
- Symposium on Drug Industry
(Magdalena Schenn, R. Ionescu; REVISTA DE CHIMIE,
No 7, Jul 85) 27
- Thermally, Chemically Resistant Enamels
(Maria Zaharescu, et al.; REVISTA DE CHIMIE, No 7, Jul 85) 29
- Acute Toxicity of Butanol, Mono-, Di-, and Tributylamine
(Maria Ciugudeanu, et al.; REVISTA DE CHIMIE, No 7, Jul 85) 38
- Achievements, Prospects for Motru-Jilt Coal Field
(N. Alecu; MINE, PETROL SI GAZE, Aug 85) 45
- Achievements, Outlook for Non-Metallic Substances
(C. Smarandescu; MINE, PETROL SI GAZE, Aug 85) 49

Development of Hardcoal Mining, Utilization in Valea Jiului (I. Costescu; MINE, PETROL SI GAZE, Aug 85)	52
Increased Achievement, Utilization in Mining Anticipated (D. Condache; MINE, PETROL SI GAZE, Aug 85)	56
Increased Copper Production at Deva Ore Central (A. Lapusca; MINE, PETROL SI GAZE, Aug 85)	59
Increased Non-Ferrous Ore Production at Baia Mare Central (N. Dieu; MINE, PETROL SI GAZE, Aug 85)	62
Use of New Polyurethane in Leather Substitute (Carmen Anghel, Tudorel Lungu; INDUSTRIA USOARA, No 5, May 85)	67

PROBLEMS WITH GETTING, KEEPING QUALIFIED PHYSICIANS DISCUSSED

Prague RUDE PRAVO in Czech 19 Jun 85 p 4

[Article: "Do We Or Don't We Have Enough Physicians?"]

[Text] The reports of the Federal Office of Statistics, among other things, inform us every year, as to the average number of citizens to one physician. In recent years, the ratio has been fewer than 300 people to one doctor, which places us in the foremost ranks in the world. Therefore it should not be a problem to ensure adequate medical services and to render them without undue delay.

The practical results, however, are not as satisfactory as the statistical data and we are receiving many complaints from our readers. In their letters, they are questioning the accuracy of the above-quoted ratio as well and keep asking where all those doctors are; because to get an appointment for almost any examination, the waiting period is extremely long. A practical example: the patient had to wait unusually long for an eye examination, because the only doctor at the particular clinic was on protracted sick leave. In equally short supply are ENT specialists, and the same applies to pediatricians, hygienists, factory physicians and others. Certain specialists are lacking in certain regions; some are lacking everywhere. In some cases it is a question of unattractive regions and in others of unattractive specialties. But this is taking it from the point of view of physicians, while the patient sees it quite differently. For him, the illness he is suffering from is the most important and the most serious one.

Concerning the doctors, we have in mind principally the practitioners in their offices or in the hospital; but the overall number applies as well to doctors in research, in laboratories, in various other functions and also to those working abroad. Nevertheless, even if we consider only those "assigned" to serve the sick, it is still important that the forces be well distributed and even the so-called unattractive specialties be well taken care of.

We cannot force anybody to work against his will where society requires it. Such arguments are used as an excuse or explanation for the penury of physicians in this or that specialty. Unfortunately, it is true. Should a doctor resign for whatever reason, it has to be accepted according to the regulations of the labor code which stipulates that everybody is entitled to choose an

employment he likes and which suits him. We can still remember the former "placement" regulations determining where a new graduate should work and what his duties there would be. It was not the best solution either, as such placement regulations solved only specific local problems at that time, while specific abilities of individuals were possibly not taken into consideration. But even here we might object; capable and aggressive individuals became outstanding specialists and their present activity is not only attractive to them but useful to society, i.e. to the patients, as well. Others have stayed at the "assigned" place and are satisfied there. Who knows indeed precisely when graduating from medical school what kind of work he will enjoy during his entire working life and where he will be most useful? In many instances, the decisive reasons at the onset are purely personal; predominantly family reasons, particularly where women doctors are concerned.

Placements are neither practiced anymore nor relied upon, but medical openings, even the less attractive ones, have to be filled. A highly developed health care program-- which the Czechoslovak health care program undoubtedly is-- operates in teams. Most certainly there are eminent surgeons, internists and cardiologists-- but it is they who never omit to mention how much the results of their work depend on the close cooperation of the whole team, not only in the hospitals, but in ambulatory services as well; that is just where the patient comes most frequently and where he receives first treatment.

Quite often we hear complaints of the leading personnel at the clinics, in sanitary care, in the districts or in individual specialties, that a graduate started working with them and from the very beginning kept saying that he intends to stay only as long as something better comes up. But as their department badly needed a doctor, they disregarded his statements, instructed him, explained to him, continued to teach him. But just when it seemed that they won him over, he showed up one day announcing that he is leaving to do something completely different, where all the acquired experience and specialization will be of no use to him.

Such cases occur obviously more often in the "unattractive" specialties than in those of a greater attraction. Such benevolence cannot continue to happen though, because it is the patients who are carrying the brunt of it.

It would seem sometimes that the medical schools produce only irresponsible graduates who follow solely their proper interests. Greater firmness at admission would be more beneficiary to the needs of the society than complaints about the irresponsibility of youth. How is it possible that young doctors change their employment almost every year and always find a position? What will be his qualification, his specialization when, having barely looked around his place of work, he is on the go again?

A considerable interest in medical studies continues to persist. Not everybody is admitted and many applicants are disappointed. Although almost every applicant for medical studies stresses his desire to become the very best doctor, only a few of the first year medical school students know exactly what their priorities are and what they should fully concentrate on during their studies. How is it possible that all the promises made upon admission

to medical school are later forgotten? Or do medical schools emphasize only certain specialties, the attractive ones? Not everybody can become a surgeon, not only because medicine has many other disciplines, but also because he might not be qualified for such work. He can, however, successfully work in another specialty. The medical school should assist the student to make the appropriate decisions based on his capabilities, interests and on the needs of the whole society as well. He should not be given orders, but be persuaded and won over.

When talking about unfilled medical openings in some districts, we could mention as an example the Northern Bohemian Kraz. But there are also other cities where, despite an abundance of applicants, there are shortages in certain specialties. A lady ophthalmologist told us, for instance, about their particular department with about 30 beds; she works there with the chief physician and two young interns. One of the interns admits openly that he took the job only because, in spite of trying, he could not find a more attractive position. It is possible that he will finally forget his initial boasting and become a good specialist. As far as the other staff members are concerned, they will do their utmost to make that happen. They are, however, asking themselves who instills such conceit into the minds of some graduates? In their opinion, more humility would become them better. They should first assert their ability and only then make demands.

12707/12955
CSO: 2400/525

GDR RESEARCH DATABANK CONSTRUCTION, APPLICATIONS REVIEWED

East Berlin INFORMATIK in German Vol 32 No 4, 1985 pp 19-20

[Article by Dietmar Keil, GDR Academy of Sciences Scientific Information Center: "Research Databanks: International Status and Experiences at the GDR Academy of Sciences in Their Construction"]

[Excerpts] 6. Experience in the Construction and Utilization of Research Databanks at the GDR Academy of Sciences

For several years now, the GDR Academy of Sciences has been devoting the necessary attention to the problems of a coordinated method for the creation and use of research databanks, oriented toward key areas of research. This involves, first and foremost, the development of long-range concepts and their application to the field of research databanks, and the creation of high-quality, transferable files. A method which is coordinated on the broadest possible level is especially important in the area of research databanks, since to obtain high-quality results which satisfy the needs of research it is necessary to make effective use of the available personnel and equipment, and in particular, to avoid insular approaches.

Some experience in the compilation and use of research databanks at the GDR Academy of Sciences is reported, with reference to examples, in the following discussion.

6.1. Setting up the Data File

The most important aspect here, aside from use of the available conventional data files, is to expand national and international lines of cooperation in order to optimize the cost of establishing high-quality research databanks. For example, institutes of the GDR Academy of Sciences are participating in the creation of a core data file as part of an international collaborative effort coordinated by the IAEA Nuclear Data Centre. The Academy of Sciences is keeping the entire updated file regularly available for this purpose.

There are also plans at the Academy of Sciences to develop a spectroscopic analysis system with integrated database, using a data file set up by a cooperating partner in COMECON.

Because of the extreme importance of cooperation in establishing high-quality, comprehensive research databanks, many databank producers are more interested in the preliminary work of creating a data file or in the exchange of data files than in the commercial sale of their research databanks. In many cases this can open up favorable conditions for the purchase of foreign research databanks based on an offer of cooperation. The marketing of bibliographic information services, on the other hand, has undergone significant development.

At a number of facilities of the GDR Academy of Sciences where results of the academy's own research are also available in the form of computer-supported data files, this situation has made it possible to import valuable research databanks from the COMECON and NSW [expansion Non-Socialist Trade Area Nichtsozialistisches Wirtschaftsgebiet unknown] sector at favorable cost, or, in some cases, free of charge.

It has also been necessary to draw on the experience of the large international data centers in order to solve the organizational and technical problems involved in initiating research databank projects.

The actual "core" of such a data center, which is responsible for the creation and management of an international research databank, consists of a small number of scientific staff members (about three to five) who are responsible for coordinating data acquisition, organizing the technical work, and managing access to the data file. The acquisition and processing of the data, such as their critical evaluation, for example, are performed on a decentralized basis by scientists at various technical facilities within the "Land"* concerned, but also located throughout the world, usually based on cooperative agreements with the facilities in question. The necessary technical processes are automated to the maximum extent and are executed by a large computer center which contracts for the work. Access to the data file, especially on-line remote access, usually takes place through specialized facilities with the appropriate technical requirements (the "hosts").

6.2 EDP for Management of Research Databanks

The GDR Academy of Science's present orientation toward expansion of the use of large- and small-computer technology follows the international trend in development, especially in the field of research automation. Consequently there is also an orientation toward the use of the appropriate existing computer technology in establishing research databanks. This is possible, for example, through cooperation with a regional computer center, as in the case of the IAEA's core data files, which undergo further processing at the computer center of the Academy of Sciences Central Institute for Isotope and Radiation Research, or the protein and gene databank of the Academy of Sciences Central Institute for Molecular Biology, which can be accessed through the computer center located there.

*"Länder" are major geographical divisions in Germany, roughly equivalent to provinces.

On the other hand, the Academy of Sciences has already acquired considerable experience in the use of small-computer technology for creating and managing small data files, as in the case of the geophysical data files at the Academy of Sciences Central Institute for Solar-Terrestrial Physics, or the oceanologic data file at the Academy of Sciences Oceanographic Institute.

6.3 Software for Management of Research Databanks

As in the creation of the data file, a step-by-step process is advantageous for developing the necessary databank software. The starting point can consist of simple programs for the storage and output of data on magnetic tapes (sequential storage), which are then gradually supplemented by new program blocks that facilitate maintenance of the data file and at the same time offer expanded research capabilities. This was how the databank at the Academy of Sciences Scientific Information Center came into being.

The universal statistical software available and used for purposes of evaluation at the Social Science Institutes of the Academy of Sciences is also being applied to the creation of research databanks in the fields of sociology and history.

In addition, Academy Institutes which are planning to set up research databanks have the option of using the databank management systems developed or available in the GDR for factual information banks, such as the TOPAS system, for example, which was developed at the Control Center for Applications Research. Many of the available program systems can be implemented both on large SER-series computers and on SKR computers, and have a broad range of application which is usually supported by a relational data model.

One elegant solution for the software problem is offered by some databank manufacturers who, on request, will deliver the appropriate computer program on magnetic tape along with the data file, as in the case of the crystallographic databanks offered by the Cambridge Crystallographic Centre in Great Britain. Here the accompanying software also includes programs for generating computer graphics.

The GDR Academy of Sciences has also gained experience in the use of bibliographic databank management systems for managing research databanks: one example is the core data file managed by the Central Institute for Isotope and Radiation Research, for which the USS modular program system is being used. A test of the application of the DIALOG program system for such purposes is being planned at the Academy of Sciences Scientific Information Center.

13114/12955
CSO: 2302/97

POLAND

NEW ENGINEERING PRODUCTS ADVERTISED

Warsaw POLISH ENGINEERING in English No 3, 1985 pp 26-30

[Excerpts] New Plant For The Recovery Of Sulphur From Petroleum

In December, last year, in the Mazovian Refinery and Petrochemical Works at Plock the assembly and start-up of a new plant for the recovery of sulphur from petroleum was completed.

Sulphur compounds are present in petroleum in the form of hydrogen sulfide gas which during processing is removed as a harmful agent and is directed to a special installation. Here, during the process of hydrogen sulfide burning, the emission of sulphur takes place of high purity determined by the value of 99.995%. Due to the application of the new plant about 3,000 tons sulphur are obtained every year accompanied by a considerable reduction of the emission of noxious sulphur compounds into the atmosphere.

So far, in the Plock Combine, similar plants have been operating imported from abroad. The new plant of an entirely own construction is based on the documentation developed by the Design Office of the Plock Petrochemical Works.

Track With Loop

The accelerated fatigue strength testing track for wheeled machines in the Industrial Institute of Construction Machines at Kobyłka represents a unique on the country scale equipment. The complete track stand on which it is possible to test the drive system and carrying structure consists of: a concrete track forming a closed 270 metre long ring road, set of exchangeable obstacles, braking trailer and equipment for automatic running and protecting of the machine tested. In the track axis a loop is laid generating an electromagnetic field that is received by the aeriels installed on the machine tested.

Frequency Converter

The TPC-6.5 is an apparatus converting three-phase mains voltage of 380/220 V into an output voltage of variable frequency and value. Its main application is feeding of three-phase induction motors of up to 5 kW in drive systems in which the control of revolution is required.

The max disposable apparent power of the converter amount to 6.5 kVA and the max. output power 12 A. The converter makes possible the control of rotary motor speed by changing the output frequency within a range from 0 to 60 Hz and change of revolutions by a breakless change of sequence of output voltage phases.

The output voltage value is adapted to the preset frequency and real load torque so that the motor power factor is approximately constant over the entire load period.

The system idea of converting mains voltage into variable frequency voltage is based on the principle of inverted with pulse width modulation, fed from an intermediary direct voltage circuit.

The basic functional units of the TPC-6.5 converter are: a rectifier, inverter and control system.

The control system of the converter is equipped with an automatic installation switch 3X10 or 16 A, forming a short-circuit protection, contactor switching on the converter for work and three mains chokes.

A key-switch and "start" - "stop" pushbuttons serve for controlling the contactor. The above equipment can be installed in the converter or in a separate mains switch unit cooperating with the converter.

Analyser of Intracranial Pressure

The microprocessor analyser of intracranial pressure serves for neurosurgical diagnosing, intensive care and examination of biomedical signals, and especially for the analysing of monitored intracranial pressure or blood pressure (mainly after neuro- and cardio-surgical operation), recording and longlasting trends of pressure changes as well as supplying of information supporting the diagnosis of intracranial system.

The application of the above analyser facilitates the detection of critical states, fast controlling of drug action and results of therapeutical operations as well as for the carrying out of medical examination and tests, e.g., the infusion tests.

The analyser is a device based on the MVY 7880 microprocessor. Its cooperation with a printer is foreseen. The analyser ensures the blending of signal, testing of standard deviation and obtaining of statistical amplitude distributions - histograms. Next to statistical analyses the apparatus makes possible the display of pressure wave run which introduces the element of morphological signal evaluation.

The work of the analyser is controlled by means of a simple keyboard equipped with programmed protection against the introduction of false instructions. Output data are presented on an alphanumeric-graphical display. The analyser samples the signals tested recording in its store the results of individual

measurements from which histograms are enumerated for a selected time period as well as the basic statistical parameters for the histogram tested (mean value and standard deviations).

The enumerated histograms and statistical parameters stored in the system data store can at any time be called by the operator onto the monitor screen. Furthermore, it is possible to form histograms composed by the operator from partial histograms stored in the data store.

Digital Capacity Meter

The CM 102A meter with automatic changing of range is a modern high-class instrument designed for precise measurement of the capacitance of all types of capacitors. It is supplied with a voltage of 220 V and its measuring ranges are: 10 nF, 0.1, 1, 10, 100 and 1000 uF. Measurement accuracy is 9.1% and for the 100-1000 uF range - 5%.

The measurement takes place by connecting the measured capacitance to the input sockets of the instrument marked HI and LO. In case of electrolytic capacitors its terminal marked "+" is to be connected with terminal HI. The measurement result is presented on a digital display. The range uF - nF is shown by means of LEDs arranged on the front panel.

Range exceeding is signalled by a periodically flickering display.

Digital Induction Gauge VISTRONIK-CD

The checking of deviations from dimensions is greatly facilitated by the use of the VISTRONIK-CD gauge provided with an induction measurement head with a large measuring range, of an order of + 5 mm. It makes it possible for the workpieces under inspection to be sorted into three dimensional groups, of which the two extreme are for workpieces out of tolerance. The measurement result is shown on a digital display. The qualification of a workpiece to a given dimensional group is indicated by a light signal. The limits of the dimensional groups are set by means of digital code switches. The VISTRONIK-CD gauge may be electrically connected with the sorting machines for controlling its operating mechanisms in accordance with the directions from the light signalling system. The measurement results may be recorded by the line printer VISOPRINT operating in conjunction with the gauge. The gauge in conjunction with the measuring stands is intended for post-process gauging.

Basic technical specifications:

- *measurement range +5000 um,
- *magnitude of basic division 1 um,
- *max. indication error 0.55% of the measuring range, +1 last digit,
- **control output (via relay) 220 V, 3 A (max. 60 VA),
- *output for recording printer +1 V within the measurement range,
- *output for line printer BCD parallel with TTL,
- *power supply 220 V, 50 Hz,
- *dimensions 390 X 150 X 310 mm,
- *weight 4 kg.

Indispensable for the Production of Fibrescopes

In the Communication Institute of Miedzeszyn, near Warsaw, the development of so called passive elements (single and multi-ply types) and of process equipment for the production of permanent joints, has been undertaken.

The Institute handles also the elaboration and construction of construction-measuring sets and instruments for laboratory-research and industrial applications. They are particularly useful at the production of high-quality fibrescopes.

The two basic pieces of equipment for the control of fibrescope damping and frequency response-developed in the Institute are already operating at the production startup in the Optotelecommunication Engineering Centre in Lublin. The third, automatic one, for determining opto-geometrical parameters is currently being tested.

Silica Reference Diodes

Electronic elements, in the form of silica reference diodes, have won a Gold Medal at the International Exhibition of Inventions and Technical Novelties INVEX'84 in Brno (Czechoslovakia). They have been developed in the Research and Development Centre for Specialized Electronic Systems MERA-OBREUS in Torun, in cooperation with the MERA-PNEFAL Process Control Instrumentation Works at Falencia.

In the last year MERA-OBREUS has turned out several thousands of such diodes and will in 1985 considerably increase production. A part of the diodes will be exported to the CMEA countries.

MERA-OBREUS can boast of a several years-long achievements in, among others, the construction and production of short series of specialist microelectronic components for industrial process control applications and use in measuring-control apparatus.

Professional Minicomputer

In the Complex Automation System Department of the Polish Academy of Sciences at Gliwice the construction of a professional minicomputer ComPAN-8 is being trained into production, in cooperation with the MERA-ELZAB Computer Equipment Plant.

The new minicomputer features a large operational capacity, graphic of high picture resolution and possibility of widening the system by specialized input-output modules.

It is applied, among others, in the automation of research processes, for instance, recording the course of experiments and processing their results,

and also for assisting the designing of microprocessor systems. One of the experimental minicomputers operates already in the United Nuclear Research Institute at Dubna near Moscow.

Unique Laser Apparatus

The laser technique finds an ever growing application in many fields of science, industry, medicine and even agriculture. Invaluable services renders the work of the Institute of Plasma Physics and Laser Microsynthesis in Warsaw where the thermonuclear plasma is examined produced with the use of large power lasers. The lasers are constructed in the Institute and occasionally many valuable developments materialize like, among others, unique measurement apparatuses.

One of such devices is the pyroelectric meter used for measuring the energy of laser pulses. It is being unsuccessfully sold in Czechoslovakia. To the United States, on the other hand, detectors of infra-red laser radiation, applied in safety sensors, are exported. Unique measuring equipment is, of course, manufactured on a small scale and on special orders only.

Cartometer KAR-A2/M

This device serves for measuring and recording rectangular co-ordinates on a plane like maps, drawings, air photographs, etc. The digital information corresponds to the value of X and Y co-ordinates and a point selected by the operator by means of an optical setting up system.

The KAR-A2/M cartometer coupled with a computer forms an independent equipment making possible, among other jobs:

- *calculation of fields of regions defined on the map by means of a sequence of points
- *transformation of co-ordinate points from a local map system to a geodetic system
- *calculation of earth mass volumes on the basis of height maps, digitalisation for designing industrial and apartment buildings, communication routes and dams
- *plotting on maps of a small number of points to preset co-ordinates.

Suitable computer programmes make possible the implementation of more complex tasks, such as:

- *formation of a numerical terrain model on the basis of contour maps
- *formation of numerical data bases for planimetric maps
- *formation of numerical data bases for assemblage work
- *accumulation of geodetic data for terrain recording requirements
- *formation of data bases for exploring raw material deposits
- *accumulation of data bases for the requirements of all kinds of design offices
- *designing of integrated and printed circuits for the electronic industry.

Technical data	
Working surface	594 X 420 mm
Resolution	0.05 mm
Possibility of measuring coordinate in millimetres and pulses	(1 pulse 0.05 mm)
Mean error of determining point co-ordinates	+0.1mm
Repeatability error of co-ordinate measurements	+0.1mm
Observation by means of an optical system of field of view	0=30 mm
Enlarging	2x

Fibrescope Welder

The Institute of Communication at Miedzeszyn near Warsaw is the manufacturer of the fibrescope welder type FOS-1 for durable jointing of fibrescope segments made of quartz glass or plastics.

The electronic part of the welder contains a system for programming the fibrescopes jointing parameters. The equipment is also equipped with mechano-optical elements making possible precise position of fibrescope and optical controlling of their location. Both parts of the welder, the mechanical and electronic part, are placed in a common housing.

/13104
CSO: 2020/38

NEW PROCESS FOR MAKING RADIATION TREATED, HEAT-SHRINKABLE PE TUBES

Warsaw WIADOMOSCI ELEKTROTECHNICZNE in English No 7-8, 1-15 Apr 85 pp 168-171

[Text] Polyethylene find now-a-days wide application in the different fields of national economy. In spite of its numerous advantages such as: perfect dielectric properties, proper mechanical and chemical qualities, as well as easy processing there are noted also some shortcomings, among others the most important: a relative low thermal resistance (permissible working temperature 70°C) low creep resistance and susceptibility to stress corrosion in various media. The most effective way to remove the aforesaid shortcomings is the cross-linking of Polyethylene by chemical methods or by ionizing radiation.

Irradiated Polyethylene is to be considered as a new material with different properties. A most characteristic feature is its increased thermal resistance. The upper range of working temperature may reach 135°C, however, the products made from that kind of Polyethylene can take a temporary thermal shock of up to 250°C, — of adequate thermal stabilizers are in use of up to 350°C. With the increase of cross-linking, a reduced susceptibility of material to cold creep and deformation under load acting above the softening point is noted. Irradiated Polyethylene is practically outstanding for its total resistance to stress corrosion in various media. Dielectric properties of Polyethylene, especially of that cross-linked by radiation methods, are not subject to any changes with regard to the properties of original thermoplastic Polyethylene. Further, the result of Polyethylene cross-linking is the valuable property, so-called „elastic memory”, permitting to use this material for the manufacture of new heat-shrinkable products, in practice irreplaceable in the con-

temporary technique and economy. These products, if put in expanded state on different objects or elements, they are shrinking after being preheated, and while returning to the former „memorized” dimensions they set firm onto the given element and take its outer shape, thus creating a tightly insulating, good protective, anti-corrosive or decorative layer.

Radiation treated Polyethylene finds wide application in many industrial branches such as: power industry, communication, cable industry, building engineering, mining electrotechnique, electronics, automotive industry, shipbuilding industry, aircraft industry and other. Application of these products determines often the grade of technical progress, it brings about a reduction of worktime, an increase of reliability and technical standard of end products — see sample as per enclosed drawing 1 and table 1.

Cable cross-section	Kind of cable box	Assembly time [h]	Weight [kg]	Other features
3x120 mm ²	Cast iron box	8	55	The box is ready to work following 6-8 hours after its execution
	Box of heatshrinkable tubes	3,5	1,8	Connection to voltage immediately after box execution

Basing on the aforesaid properties of Polyethylene, the ENERGOKABEL Research and Development Centre of Cable Industry (Ośrodek Badawczo-Rozwojowy Przemysłu Kablowego ENERGOKABEL) in co-operation with contemporary Institute of Nuclear Research, Department of Radiation Chemistry (Zakład Chemii Radiacyjnej Instytutu Badań Jądrowych) elaborated and introduced in the production process an original technology for the manufacture of heat-shrinkable tubing. There have been also designed and manufactured all the machines and equipment necessary for that production. The manufacturing process of heatshrinkable tubes, as well as equipment for their production, received several Polish patents.

Production principle for heat-shrinkable PE-tubes is as follows:

● The tube from thermoplastic Polyethylene cross-linked by irradiation is heated up to a temperature above the softening point of thermoplastic PE? i.e. above 120°C. Then the heated up tube is expanded perpendicularly to its axis in the forming pipe with required dimension, under the influence of inner high pressure. This enables to reach a two or threefold increase of tube diameter, and its immediate cooling causes a „freezing” of deformations through a recrystallization; the tube keeps its new dimension and shape.

● A special problem is the selection of material (with regard to the molecular structure of Polymer, kind and contents of antioxidants and other additives), suitable for irradiation, i.e. for cross-linking under relative small radiation dose, as well as for the production of heatshrinking tubes. Among the high number of commercial Polyethylene types from Poland and abroad, tested so far, only few of them have been classified as suitable for the production. Any additives introduced to PE, aiming either at further modification of its properties, e.g. reducing of the combustibility, or for its colouring only, have a great influence, often a disadvantageous, both on the radiation process as well as on the properties of the cross-linked material.

The technological process of heat-shrinkable tubes comprises 3 basic stages, i.e.:

- processing of the material (I. stage),
- irradiation treatment (II. stage),
- expanding of tubes (III. stage).

Processing of material

Processing of tubes comprises the extrusion moulding of „raw” tubes, using special extruder lines, like these used in the cable industry. Each extruder is provided with suction equipment conveying the raw material (Polyethylene) from the container to the charging hopper of the extruder. Important for this process is to obtain tubes with low grade cross-link orientation. This was reached by using vacuum diaphragm calibration and special designed forming heads, permitting to stabilize the linear dimension of tube through the minimizing of the longitudinal shrinkage.

Irradiation treatment

Irradiation treatment of produced „raw” tubes takes place by means accelerated electrons from accelerator placed in a shielded bunker. According to the operation principle of the accelerator, the acceleration of electrons is reached under high frequency voltage produced in the resonator which forms the accelerating structure. The simple design of accelerating parts contributes to a reduced standstill time for the removing of possible breakdown. Irradiation treatment of PE tubes with small and middle dimensions takes place by means of scanned electron beam, applying the standard or alternating rewinding system, and rectangulator irradiation tube of max dimensions 75 × 900 mm with possible adjustment. For highdimensioned PE tubes the irradiation takes place by means of electron beam divided by special bending system in three beams operating, from three directions, at an angle of 120°C to each other.

Accelerator feeding and control equipment is placed in a separate room adjacent to the accelerator room. For the visual inspection of the radiation process three monitors are used which are installed in the control room. Images are transferred from the industrial television cameras placed in the accelerator bunker for the observation of tube rewinding equipment and of the direct radiation field of tubing under the accelerator tube, furthermore, for the observation of pay-off and take-up units in front of the accelerator bunker.

Expanding of tubes

Expanding process is performed by means of compressed air flux and special equipment for continuous (smaller diameters) or sectional (larger diameters) expansion. This process allows to expand the tubes two or threefold with relation to the initial diameter. For this purpose the irradiated tube has to pass through the heating set where it is pre-heated to the required temperature. After leaving the heater, the tube passes through the forming and cooling set, and here the compressed air flowing in the tube causes its expansion to a higher dimension determined by the calibrating pipe.

EQUIPMENT FOR THE PRODUCTION OF HEAT-SHRINKABLE TUBES

Taking into consideration the wide range of tube dimensions used in practice, (for example tube diameters in delivery state amount from 2,4 up to 250 mm), a partition into three groups was undertaken (thin-walled tubes, middle-walled tubes and thick-walled tubes), depending on the diameter, wall thickness and radiation way, — from one or three „windows” in the accelerator chamber.

Apart from the extruder lines for the extrusion of „raw” tubes and from the accelerator for the radiation process, the following equipment is necessary:

1. Equipment for the radiation of „thin” tubes type RC 2,4/1,2×0,51 up to pe RC 9,5/4,8×0,64 under an accelerator.

The complete set of equipment comprises:

- Mobile truck set consisting of frame, carriage system, drum driving system, four drums and control system. The carriage system is used for the selfacting placing of the truck with drums and „raw” tubes within determined time periods — each drum in sequence — under the accelerator gap. Displacing intervals adjustable up to 1 minute, while the radiation process for 1 drum can be adjusted from 2 up to 6 minutes. Drums fixed in centres, one of them (for each drum) driven. Following the radiation process of tubes reeled on all 4 drums, the accelerator is switched off and the truck with drums replaced by another. It is possible to build a device for remote control of drum exchanging or to apply a special conveyor, — this equipment would be, however, very expensive and thus not economical.

- Rewinder — for the rewinding of „raw” tubes from the take-up drums in the extruder line (drum outer diameter up to 1000 mm) on special drums of 800 mm dia. Rewinder consisting of: Pay-off unit, compensator, winder, control system. Considering the extremely small diameters of tubes rewound, the pay-off unit is driven. Lifting of pay-off and take-up (winder) drums: mechanically or pneumatically. Drum fixing: in centres. A special problem is the accurate laying-up of the tube on the take-up drum.

Fig. 1. Comparison of traditional cable box structure with the box from heat-shrinkable tubes: a) cast iron cable box

1 — cable box upper half, 2 — cover, 3 — filling compound, 4 — cable box bottom half, 5 — earthing screw, 6 — clamp, 7 — screw for the fixing of cable box halves, 8 — cable sealing, 9 — cable covering, 10 — armour, 11 — lead sheath, 12 — core insulation, 13 — additional insulation
b) cable box made from heat-shrinkable tubes
1 — heat-fusible glue, 2 — outer tube, 3 — inner tube, 4 — cores, 5 — core insulation, 6 — cable sheath

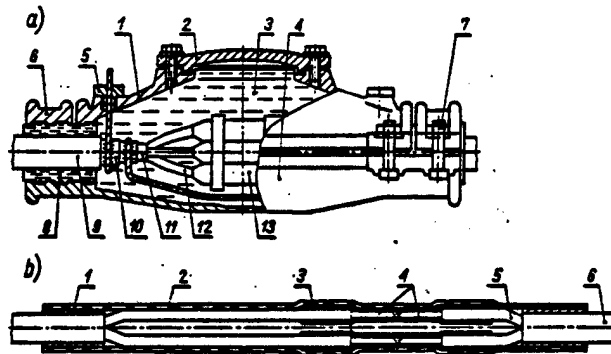

MC-977/1

● Rewinder — for the rewinding of tubes cross-linked by irradiation from the special drum of 800 mm dia on pay-off bobbins of the equipment for continuous tube expanding. Rewinder consisting of: Pay-off unit, compensator, winder for the reeling of tubes on bobbins of outer diameter 350 up to 500 mm, and control cabinet. Pay-off drums and take-up bobbins fixed in centres, one of them being driven.

2. Equipment for the irradiation under an accelerator of „middle” tubes type RC 9,5/4,8×0,64 up to 23,4/12,7×0,89, as well as type RP 12/4×2 up to 40/16×2.

Basic sets of this equipment:

— on input side of the accelerator chamber: pay-off unit for drum dia 1600 or 2400 mm, compensator and rolls guiding the tube to the accelerator gap,

— roller set in the accelerator chamber for the rewinding of tube under the accelerator gap,

— on the output side of the chamber: rollers, guiding the irradiated tube to the compensator and winder reeling the irradiated tube on drums of 1600 or 2400 mm diameter.

Owing to the small diameters of tubes re wound, the pay-off unit is driven. Lifting of drums in the pay-off unit and winder: mechanically. Drum fixing: in centres. A roller set serves for the rewinding of tubes under the accelerator with a speed depending on the given diameter and wall thickness of the tube, in order to supply the quantity of energy required for the radiation process. Radiation process may take place for a limited range of tube dimensions in one-side system (lengthwise laying-up), or left-side radiation system.

Voltage supply system and control system are incorporated in the control cabinet placed outside of the accelerator chamber.

3. Equipment for the irradiation under an accelerator of „thick” tubes type RC 38/19×1,02 up to 102/51×1,4, RP 40/16¹⁾ up to 132/58×2,5, as well as type RG 50/18²⁾ up to 128/55×4,0.

Basic sets of this equipment:

— on input side of the accelerator chamber: pay-off unit (like that for „middle” tubes), compensator and rollers guiding the tube to the accelerator gap,

— two stands with rewinding rolls

— in the accelerator chamber,

— on the output side of the cham-

ber: rollers guiding the irradiated tube to the compensator, compensator and winder (like that for „middle” tubes).

The proper rewinding equipment is adapted to an accelerator tube for three-side radiation process designed as equilateral triangle with

¹⁾ Pipe symbols: RC — thin-walled PE tubes (0,4 up to 1,4 mm), RP — middle-walled PE tubes (2,0 up to 2,5 mm), RG — thick-walled PE-tubes (2,0 up to 4,0 mm).

„windows” in its flanks for the electron beams. This rewinding equipment consists of two stands, each with 2 rollers of 1600 mm dia, the roller set at the winder side being driven.

Considering the co-operation of rewinding sets with the accelerator, it is necessary to agree each time with the customer upon the signalling and control systems, as well the interlocking set.

4. Cutting equipment — for the cutting of „thick” tubes to sections. For the irradiation processing of tubes according to the section method, it is necessary to use a device for the cutting of cross-linked tubes reeled on the drums to sections of defined length. Cutting equipment consists of: Pay-off unit suitable for drum diameters 1600 and 2400 mm, haul-off unit driven by D.C. motor ensuring an infinitely variable speed adjustment from 0,4 up to 9 m/min, circular saw for tube cutting, storage equipment for tube sections of optional length up to 6 m.

5. Equipment type RR-C1 for the continuous expanding of „thin” PE-tubes cross-linked by radiation.

This equipment permitting a two up to three-fold expanding of tube diameter consists of: pay-off unit for 4 bobbins fixed on hollow axes, allowing to supply compressed air to the PE-tube reeled on these bobbins, of roller systems feeding the tube with infinitely variable speed synchronized with the haul-off speed, and adjustable gap between the rollers, of heating system for the heating of PE-tube in a heating bath with the accuracy of $\pm 1^\circ\text{C}$, cooler for the tube cooling after its expanding, cutting equipment — cutting the tube to sections of adjustable length.

This equipment adapted to simultaneous expanding of four tubes with a diameter range before expanding from 1,2 up to 7 mm, with linear speed up to 120 m/h.

6. Equipment type RR-S2 for continuous expanding of „middle” PE-tube cross-linked by irradiation.

This equipment allowing a two up to three-fold expanding of the diameter consists of: driven pay-off unit for 2 drums of dia up to 1000 mm fixed on hollow shafts which permit to supply compressed air to the PE-tube reeled on these drums, of feeding roller system, heating system, cooler and cutting equipment for the cutting of tube to sections of adjustable length.

This equipment is adapted for simultaneous expanding of two tubes with diameters before expanding from 6 up to 19 mm, with a linear speed up to 120 m/h.

7. Equipment type RR-G1 for continuous expanding of „thick” PE-tube cross-linked by irradiation. Equipment enabling to expand the

tube diameter 2 up to 4-fold consists of: pay-off unit for one drum mechanically lifted and driven with adjustable speed, fixed on special centres allowing to supply compressed air to the tube reeled on the drum, of haul-off unit feeding the tube with infinitely variable speed synchronized with the speed of haul-off rollers, of circulatory heat exchange system with an accuracy of $\pm 1,5^{\circ}\text{C}$, of forming and cooling equipment, as well as of cutting equipment.

It serves for the expanding of tubes with diameters before expanding from 16 up to 60 mm with a linear speed up to 60 m/h.

8. Equipment type ARO for the expanding of PE-tube in sections. This equipment makes possible a two up a three-fold expansion of the tube diameter. It consists of:

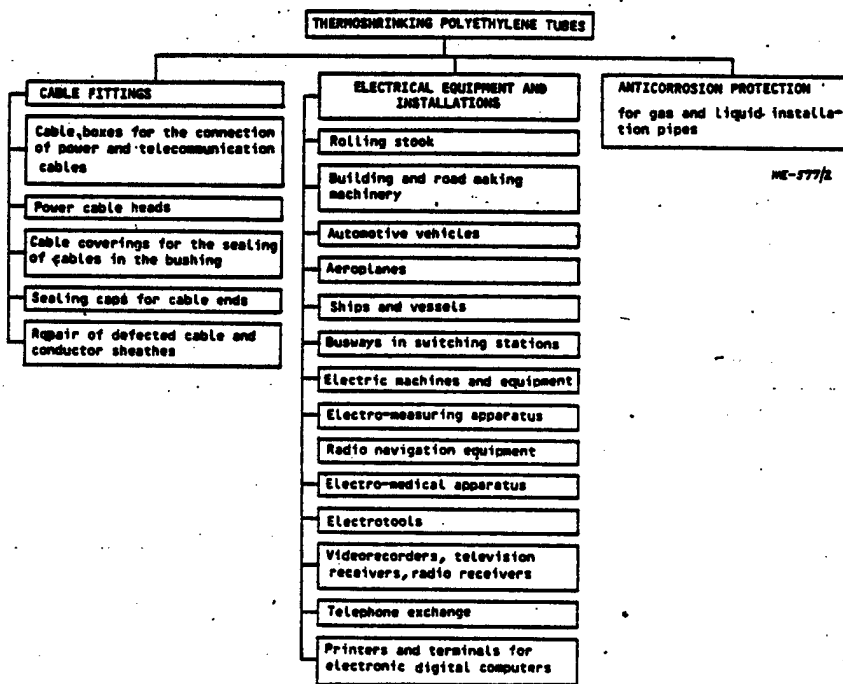

Fig. 2. Main application fields for PE-tubes with „Elastic Memory”

heater, disk with 12 tube holders, disk drive, driving screw with calibrating pipe, pneumatic and electric system.

The irradiated PE-tube shut up at the bottom is pushed into the holder on the rotary disk. Owing to the cyclic revolution of the disk round about its own axis, the PE-tube passes through the heater.

Forced air circulation ensures an uniform temperature of the PE-tube of about 170°C . After leaving the heater the PE-tube is introduced into the calibrating pipe where it is expanded under the influence of compressed air.

Operation of equipment: in semi-automatic system, i.e. putting on and off of the PE-tube is perfor-

med manually, the remaining operations are performed automatically.

This equipment is used for the expansion of tubes with diameters from 16 up to 125 mm before their expanding (after expanding from 42 up to 250 mm) with an output up to 90 pieces/hour.

9. Glue injection equipment.

In case of special requirements with regard to the tightness of connections, the inside of heat-shrinkable tubes is covered with glue or sealing compounds. For this purpose the following equipment is used: glue containers (main and auxiliary container), electro-mechanical drive, thermostat and baseplate. Thermofusible glue and sealing compound are melted in the container under the influence of the stabilized temperature of electrically heated container walls. Each container is provided with a pump forcing the glue to special nozzles covering the inner walls of PE-tubes. Pump drive: by D.C. motor with adjustable speed.

POLISH OFFER:

Research and Development Centre ENERGOKABEL; the Institute of Nuclear Chemistry and Technology and Cable Factory CZŁUCHOW offer through the Foreign Trade Enterprise ELEKTRIM:

- delivery of machines and equipment necessary for the production of heat-shrinkable tubes, covering the complete range of diameters,
- technical documentation and

working drawings for the preparing and execution of accommodations for the machines, equipment and electro-energetic installations, automatics, industrial television, water supply and sewerage systems, cooling water system and other installations necessary for a correct and safe production process,

— training of the personnel at the Customer's and Polish plants,

— delivery of heat-shrinkable caps covering the following range of diameter from 10/4/48 up to 90/45/123.

We wish to stress that our machines, equipment and products are outstanding for their quality and original, solid design. They require little maintenance and provide no trouble in exploitation. They operate for several yeards in Poland; groups of these machines and equipment have been exported also to the German Federal Republic and to Switzerland.

— supervision of building and installation work performed, as of the assembly of machines and equipment,

— Know-how comprising:

- technical conditions and standards for heat-shrinkable tubes,
- technology having the form of instruction cards for individual operations, including: material consumption standards, worktime standards, data on materials used (Polyethylene), service manuals etc.

— delivery of heat-shrinkable PE-tubes covering the following of diameters from RC 2,4/1,2×0,51 up to 220/60×5,

/13104

CSO: 2020/36

ROMANIA

SYNTHESIS OF TRICYCLIC ANTIDEPRESSIVE DRUGS

Bucharest REVISTA DE CHIMIE in Romanian No 7, Jul 85 pp 617-620

[Article by Dorin Brezeanu, Mircea Scifos, Emil Pop, and Rodica Miloia, Institute for Chemical-Pharmaceutical Research, Cluj-Napoca]

[Text] Psychotropic products belong to the large class of substances that act upon the central nervous system. One major class of such substances consists of the tricyclic antidepressive drugs. This paper describes the synthesis of Amitriptylene and Nortriptylene (tricyclic antidepressives), which are currently produced in Romania.

Psychopharmacologic or psychotropic substances act upon the central nervous system with various effects on psychologic functions. Antidepressive drugs are one large class of such substances; they are used to combat psychological depression, melancholia, chronic fatigue, and in general, to stimulate the tonus of neuropsychological activities. They are also known as thymoleptics, psychomotor stimulators, psychological energizers, psychotonics, or mood stimulators.

Just as in the case of schizophrenia before the introduction of treatments based on electroconvulsive therapy or other forms of shock (in the 1930's), no effective treatment was available for depressive illness. Electric shock produced acceptable results, becoming together with psychotherapy, the major form of treatment until the end of the fifth decade, when the first antidepressive drugs were discovered.

The discovery of tricyclic antidepressives (a second category of antidepressives are the monoaminoxidase inhibitors, IMAO, substances with heterogeneous structures and more limited use) constituted a true revolution in the treatment of depressive illness. The utilization of these substances grew together with the nervous system problems generated by the development of technology, the pace of life, increasing nervous tension, stress, and a higher average age.

Structurally, most of these products consisted of a tricyclic system with a central ring composed of seven atoms, framed by two benzene nuclei, and with a lateral chain, generally of three carbon atoms, which contains a tertiary amine group.

Many derivatives exist whose lateral chain has been variously modified, in which substitutes have been introduced in the benzene nuclei, or whose central ring was modified by the introduction of a double bond, a heteroatom, or a substitute. The effects produced by these modifications have not been spectacular, but diversification in this type of products is not without justification, since psychological patients represent a heterogeneous group reacting differently to one or another drug. It is certain however that until now, the most widely used antidepressive drugs have been the classic ones, Amitriptylene and Nortriptylene, in the category of those whose basic tricyclic system is 10,11-dihydro-5H-dibenzo-[a,d]-cycloheptene, as well as Imipramine in the class of dibenzoazepines

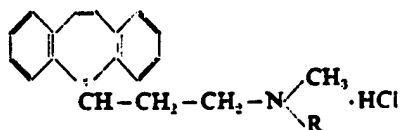

R = -CH₃ Amitriptilina
R = H Nortriptilina

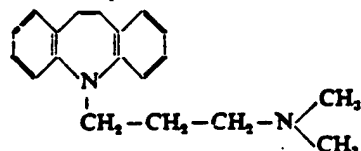

Imipramina

Given the great demand for these drugs on the domestic and foreign markets, we have studied the synthesis of the principal representatives, Amitriptylene and Nortriptylene, as a first step, followed by some representative dibenzoazepines (Anafranil, Tegretol). The goal of these studies was to develop manufacturing technologies competitive on the world market, hence with a high economic efficiency, applicable in industry, and to thus create a basis for Romanian production of antidepressive psychotropic drugs.

Pilot technical processes for Amitriptylene and Nortriptylene were developed in 1977 and 1978 (and the technologies for Anafranil and Tegretol were finalized in 1981). These processes were based on laboratory and pilot studies, and are characterized by an exceptional degree of originality.

Given the special nature of the work, the problems that were studied will be discussed without entering into great detail, indicating in the bibliography the applicable patents or scientific papers.

Considering the plan to develop manufacturing technologies for both Amitriptylene [1] and Nortriptylene [2], we selected a synthesis which would be common to both products until the most advanced possible phase, thus avoiding the need to design two different production lines.

The first step of the synthesis was designed to obtain trans-benzylidene-phtalide. We studied the Perkin condensation of phtalic anhydride with phenylacetic acid, obtaining high yields and a very high purity intermediate [3].

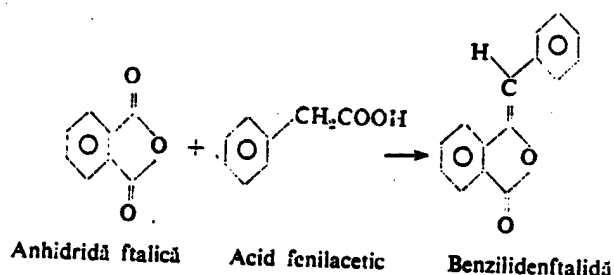

We calculated molecular orbitals using the Pariser-Parr π -electron method, in order to examine the electronic spectra and several properties of the fundamental state of the two benzylidenephtalide isomers (the trans isomer resulting from the synthesis and the cis isomer obtained by another process). We thus examined the UV spectra of the two isomers, as well as the reactivities of some atomic positions, comparing them with phthalic anhydride; calculations on the latter were performed using the same method and the same set of parameters, the results being the subject of scientific communications [4,5].

The next step of the synthesis was to obtain 2-(phenyl)benzoic acid. It was prepared by reducing phenylacetylbenzoic acid derived from the alkaline hydrolysis of benzylidenephtalide; for its preparation, we investigated several approaches, both direct, in which the carbonyl group is reduced to methylene in a single step, as well as indirect, in which the first stage leads to the production of alcohol, which following dehydration into trans-stilbene-*o*-carbonic acid and its reduction, leads to 2-(phenyl)benzoic acid:

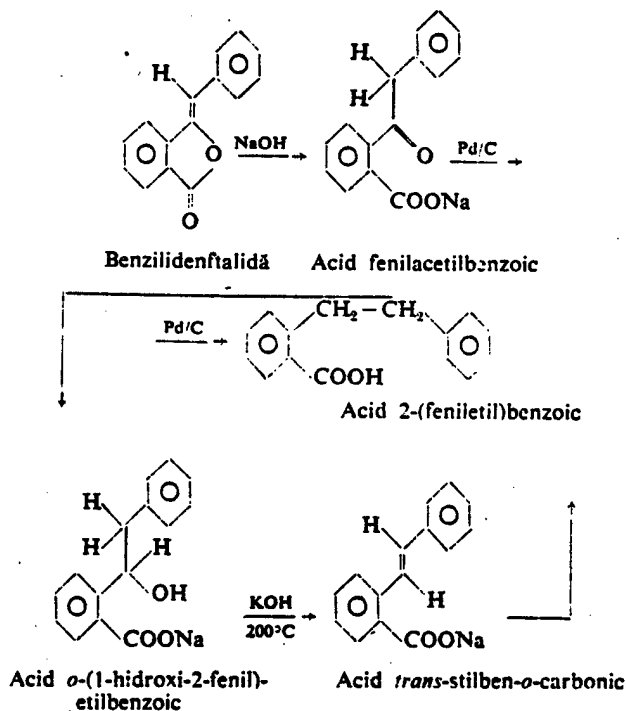

Among the direct methods, we studied catalytic hydrogenation with palladium/charcoal and with nickel (Raney or Urushibara), and the classic method with hydrogen iodide or red phosphorus. Among other methods, we experimented with electrolytic reduction, reduction with zinc and nickel, as well as Clemmensen and Kishner-Wolff reductions. After obtaining o-(1-hydroxy-2-phenyl)-ethylbenzoic acid, an original method using ethylene glycol as the reaction medium, was developed for the dehydration phase. The original features of the experiments for this phase are described in references [6-8].

The next stage, the preparation of 10,11-dihydro-5H-dibenzo-[a,d]-cycloheptene-5-one, was investigated through several avenues: using polyphosphoric acid as cyclization agent and through the intermediate of the acid chloride, in the presence of anhydrous aluminum chloride (Friedel-Crafts intramolecular acylation). We have formulated an original method through the intermediate of the chloride of 2-(phenylethyl) benzoic acid, in a dichloromethane medium, at an appropriate dilution, so as to prevent intramolecular reactions; it is a simple method, readily adapted to industrialization, and operating with high yields [9].

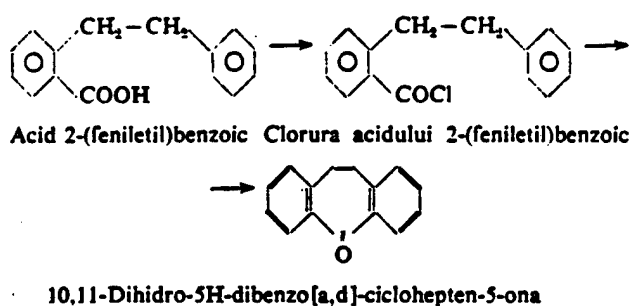

The lateral chain is introduced with a Grignard reaction. The Grignard reagent, dimethylaminopropylmagnesium chloride, is prepared from 1,3-dimethylaminopropanol via 1,3-dimethylaminochloropropane chlorhydrate and a free base. The reaction is carried out in tetrahydrofurane. We have perfected an original method for isolating and purifying the resulting carbinol [10]:

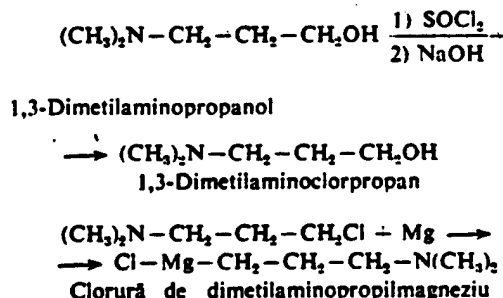

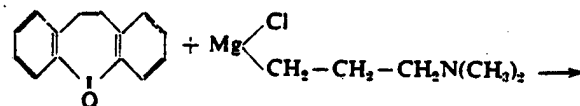

10,10-Dihidro-5H-dibenzo-
[a,d]-ciclohepten-5-ona

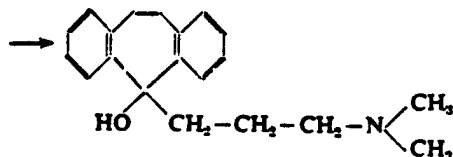

10,11-Dihidro-N,N-dimetil-5H-dibenzo-
[a,d]-ciclohepten-5-hidroxi-
5-propilamina (Carbinol)

The basic intermediate for both Amitriptylene and Nortriptylene is 10,11-dihydro-N,N-dimethyl-5H-dibenzo-[a,d]-cycloheptene-5-hydroxy-5-propylamine (carbinol).

Amitriptylene is synthesized by dehydrating carbinol, using various dehydrating agents. New possibilities have been found in lieu of the generally used dehydrating agents: methanol hydrochloric acid and isopropanol hydrochloric acid. The first was used successfully in the synthesis of Nortriptylene in particular; using the second, Amitriptylene can be obtained directly with high purity:

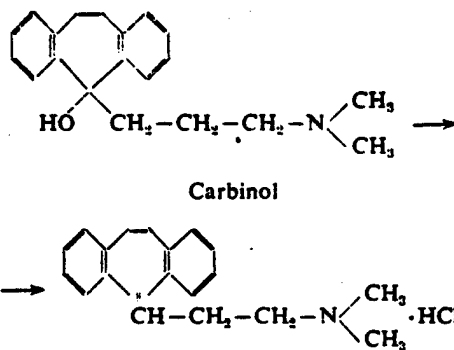

Clorhidratul 10,11-dihidro-N, N-dimetil-5H-dibenzo-[a,
d]-ciclohepten- $\Delta^{\beta\gamma}$ -propilamina (Amitriptilina)

Data regarding the synthesis itself, purification of the finished product, and recovery of the product from the mother liquor, is included in patents [11-14].

Although many versions do exist, a common method was selected for Amitriptylene up to 10,11-dihydro-N,N-dimethyl-5H-dibenzo-[a,d]-cycloheptene-5-hydroxy-5-propylamine. In the first stage, the carbinol is dehydrated to obtain Amitriptylene, which is transformed into a base through alkalinization. In the next stage, a methyl group at the nitrogen atom of the lateral chain is

replaced with a hydrogen atom. Different approaches were tested for this: with ethyl chloroformate, with the chloride of the p-toluenesulfonic acid, with methyl iodide, and so on, the most advantageous being the one which uses ethyl chloroformate. This method proceeds through the intermediate of N-carbetoxy-(10,11-dihydro-N-carbetoxy-N-methylamino-5H-dibenzo-[a,d]-cycloheptene- $\Delta^5\gamma$ -propylamine) derivative, which through alkaline hydrolysis leads to Nortriptylene:

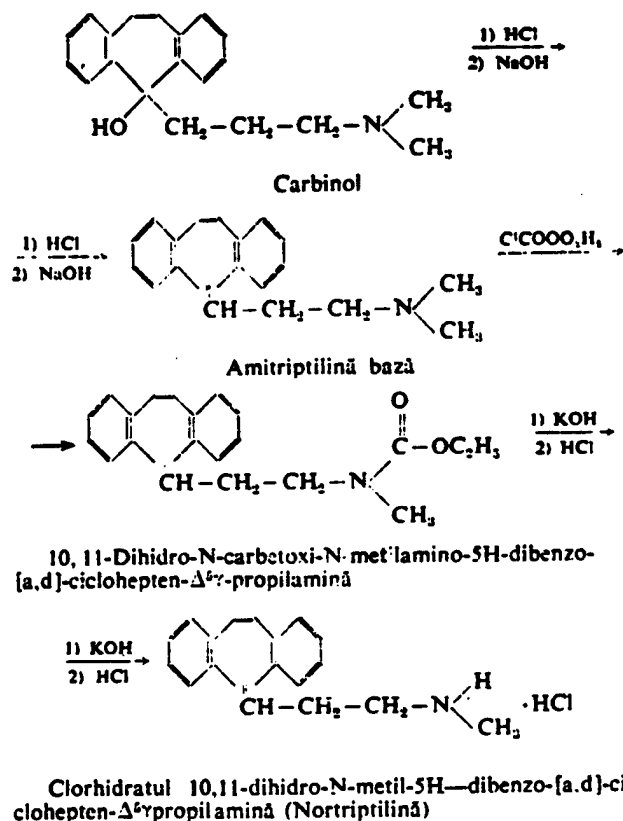

We thus start with carbinol, which is dehydrated with methanol hydrochloric acid; the Amitriptylene thus obtained is transformed into a base, and without isolation, is further transformed into the N-carbetoxy derivative with ethyl chloroformate; the derivative is then hydrolyzed with butanol potassium hydroxide. The resulting Nortriptylene is isolated and purified through recrystallization from isopropyl alcohol. The novel features of the synthesis are patented [15].

The syntheses of Amitriptylene and Nortriptylene were the subject of two communicated scientific papers [16,17].

The two technologies offer outstanding economic advantages. Yields at each stage are high and the cost of the products is much lower than that of similar imported products. We might add that the quality of the products is very

good, meeting the requirements of all pharmacopeias. The technologies have proven to be reproducible (yields, specific consumptions, product quality) during their industrialization at the production unit (IM Terapia, Cluj-Napoca).

Amitriptylene and Nortriptylene are the first antidepressive psychotropic products whose technology was developed in our country. They will form the basis of a drug industry of this type, with a more diversified range to follow in future years.

REFERENCES

1. E. Pop, B. Kovacs, M. Scifos, and Breazu: 10,11-dihydro-N,N-dimethyl-5H-dibenzo[a,d]-cycloheptene- $\Delta^5\gamma$ -propylamine clorhydrate (Amitriptylene), unpublished data.
2. E. Pop, B. Kovacs, M. Scifos, M. Lenta, and D. Breazu: 10,11-dihydro-N-methyl-5H-dibenzo[a,d]-cycloheptene- $\Delta^5\gamma$ -propylamine clorhydrate (Nortriptylene), unpublished data.
3. E. Pop, M. Scifos, and B. Kovacs: "Preparation Process for Trans-benzilidenephtalide," Romanian Patent No 72334, 1979.
4. E. Pop, R. Pop, B. Kovacs, and M. Scifos: "Theoretical Study of Benzilidenephtalide Isomers," Fifth National Conference of General and Applied Physical Chemistry, Bucharest, 1976.
5. E. Pop, B. Kovacs, M. Scifos, and R. Pop: "Study of Some Properties of the Fundamental State of Benzilidenephtalides," Sixth Symposium on Research and Utilization of Medicinal Products and Biostimulators, Bucharest, 1977.
6. B. Kovacs, E. Pop, M. Scifos, and R. Calmic: "Process for Obtaining 2-(phenyl)benzoic Acid," Romanian Patent No 69892, 1979.
7. B. Kovacs, E. Pop, M. Scifos: "Preparation of O-phenylethyl Benzoic Acid from 3-benzilidenephtalide," Communications Session at ICCF (Pharmaceutical-Chemical Research Institute), Cluj-Napoca, 1976.
8. B. Kovacs, E. Pop, M. Scifos, and R. Calmic: "Study of 3-benzilidene-phtalide Reduction," Scientific Session of Teaching Staff and Students at Babes-Bolyai University, Cluj-Napoca, 1977.
9. E. Pop, M. Scifos, B. Kovacs: "Process for Obtaining 10,11-dihydro-5H-dibenzo[a,d]-cycloheptene-5-one," Romanian Patent No 66775, 1977.
10. E. Pop, B. Kovacs, M. Scifos, and O. Piroasca: "Process for Obtaining 10,11-dihydro-N,N-dimethyl-5H-dibenzo[a,d]-cycloheptene-5-hydroxy-5-propyl amine," Romanian Patent No 71735, 1979.

11. E. Pop, B. Kovacs, M. Scifos, and M. Peterlecean: "Process for Preparing 10,11-dihydro-N,N-dimethyl-5H-dibenzo[a,d]-cycloheptene- $\Delta^5\gamma$ -propylamine Chlorhydrate (Amitriptylene)," Romanian Patent No 71794, 1979.
12. E. Pop, B. Kovacs, M. Scifos, and R. Calmic: "Purification Process for 10,11-dihydro-N,N-dimethyl-5H-dibenzo[a,d]-cycloheptene- $\Delta^5\gamma$ -propylamine (Amitriptylene)," Romanian Patent No 71793, 1979.
13. E. Pop, B. Kovacs, M. Scifos, and R. Calmic: "Recovery Process for 10,11-dihydro-N,N-dimethyl-5H-dibenzo[a,d]-cycloheptene- $\Delta^5\gamma$ -propylamine (Amitriptylene)," Romanian Patent No 71792, 1979.
14. E. Pop, M. Scifos, B. Kovacs: "Process for Obtaining Pure 10,11-dihydro-N,N-dimethyl-5H-dibenzo[a,d]-cycloheptene- $\Delta^5\gamma$ -propylamine (Amitriptylene)," Romanian Patent No 76312, 1980.
15. E. Pop, B. Kovacs, M. Scifos, and R. Calmic: "Preparation Process for 10,11-dihydro-N-methyl-5H-dibenzo[a,d]-cycloheptene- $\Delta^5\gamma$ -propylamine (Nortriptylene)," Romanian Patent No 76340, 1980.
16. E. Pop, B. Kovacs, M. Scifos, and L. Lenta: "Contributions to the Synthesis of Pharmaceutical Products with Psychotropic Action," Scientific Communication Session "New Research in Pharmaceuticals," Tirgu-Mures, 1978.
17. E. Pop, M. Scifos, B. Kovacs, L. Lenta, and R. Miloia: "Studies of the Synthesis of Some Antidepressive Substances," Symposium on New Developments in Medication Research, ICCF, Cluj-Napoca, 1978.

Received 11 December 1984

11,023

CSO: 2702/2

ROMANIA

SYMPOSIUM ON DRUG INDUSTRY

Bucharest REVISTA DE CHIMIE in Romanian No 7, Jul 85 p 644

[Article by Magdalena Schenn and R. Ionescu]

[Text] Among the actions undertaken by the National Council of Engineers and Technicians, and as part of National Festival Cintarea Romaniei, a symposium-conference on the Application and Dissemination of Inventions in the Drug Industry was held in Bucharest on 7-8 June 1985.

The meeting was organized by the National Council of Engineers and Technicians, the Ministry of the Chemical Industry, and the State Office for Inventions and Brands, and was attended by many specialists.

The purpose of the symposium was to stimulate the exploitation of pharmaceutical inventions that have been granted patents. Of primary interest were inventions based on domestic active substances which do not require imported raw materials.

Papers and communications were read by authors from more than 20 Institutes and Enterprises in Bucharest, Cluj-Napoca, Timisoara, Brasov, Piatra-Neamt, Iasi, Oradea, and Tirgu-Mures.

The 38 papers and communications described the possibility of obtaining valuable pharmaceutical products or cosmetic compounds, competitive with similar imported products.

These contributions presented the exploitation of domestic raw materials obtained from plants, animal products, and mineral or synthesized materials; some of them concerned:

New processes for producing extracts from plants that grow wild;

Utilization of waste from tomato processing in the food industry;

Derivation of a total alkaloid from ergot;

Utilization of Bazna and Baltatesti salt in a washable ointment base;

Utilization of antihyaluronidase of animal origin--cartilage extract;

Increased bioproductive potential for a weakly producing strain of penicillinase;

Development of an anti-infective and anti-inflammatory drug from natural and synthesized products;

Processes for fabricating cytostatic products from synthesized materials;

Also of great interest were the papers referring to the production of drugs for the treatment of diseases, such as:

Cytostatic products (cyclophosphamide and Cisplatin) and products for restoring unhealthy cells;

Cicatrizant and regenerative drugs for burns and wounds (Cicatrol and Plastogel);

Hepatobiliaries (produced at Plantavorel in Piatra Neamt) and hepatoprotectives (Regopar and Tonobil);

Anti-infective and anti-inflammatory drugs (Mecolzol);

Hemostatics and anti-inflammatories (Venoruton);

An antiprolactin drug with therapeutic action in obstetrics and gynecology, as well as in some neuroendocrine diseases;

Antibiotics (tylosine and Sodium Cefalotin).

The topics discussed in the papers demonstrated the concern of specialists for a superior utilization of domestic raw materials to obtain products that will supply necessary pharmaceuticals, thus helping reduce importations.

Following the delivery of papers and the discussions of the specialists, a number of measures will be taken to manufacture these products, measures which require a closer collaboration between research and production units in various ministries.

11,023

CSO: 2702/2

ROMANIA

THERMALLY, CHEMICALLY RESISTANT ENAMELS

Bucharest REVISTA DE CHIMIE in Romanian No 7, Jul 85 p 656-659

[Article by Maria Zaharescu, Georgeta Jitianu, Eva Barbulescu, and Melania Pascut, Bucharest Research Center for Anticorrosion Protection, Lacquers, and Paints, and Gheorghe Maican and Eugen Dan, Fagaras Enterprise for Chemical Equipment]

[Text] The physical and chemical criteria underlying the synthesis of thermally and chemically resistant enamels are discussed. An empirical correlation is established between the chemical stability of frits and that of the corresponding enamels. The properties of the enamels have been tested both by standard methods and by studying their behavior during the enameling process. A vitreous crystalline enamel with improved technical and product qualities was produced.

The growth of the chemical industry and the development of new technologies has led not only to a quantitative growth in the production of chemical equipment, but also to the creation of new materials to meet more stringent requirements. Many chemical processes are currently using highly corrosive products at high temperatures and pressures. Non-ferrous metals and alloys, special steels, or plastics do not always meet the technical demands raised by the chemical industry. In an increasingly large number of cases, the requirements of technical processes can be met only by enamel-covered steel.

Enamelled products combine the advantages of metals (mechanical and thermal resistance) with those of glass (good corrosion resistance, hard and smooth surface, easy cleaning), while somewhat reducing the fragility of glass, thus allowing its use in many fields, such as the basic chemical industry, pharmaceuticals, elastomer synthesis, the food industry, and so on. The Fagaras Chemical Equipment Enterprise is presently manufacturing vitreous enamels with good chemical resistance to acid or alkaline media [1].

An analysis of the use of enamelled equipment in the chemical industry has shown that only about 2 percent of the products are withdrawn from use as a result of chemical corrosion, the cause being the unsatisfactory thermal and mechanical characteristics of the enamel [2]. The statistical data also indicates that 40-50 percent of installation failures are due to thermal shocks, and 25-30 percent to abrasion and mechanical shocks.

The purpose of this research was to create chemical enamels with high thermal resistance, in order to increase the lifetime and reliability of enameled equipment.

I. Criteria for Formulating Enamels with Good Chemical and Thermal Resistance

It is well known that any enameled chemical ware consists of a metal object, a ground coat--which adheres to the metal support as a transition from metal to vitreous coating, and the coating enamel which provides corrosion protection.

The formulation of recipes for chemical enamels is a particularly difficult problem because it must satisfy a number of intrinsic characteristics of the material--chemical, thermal, and mechanical resistance, while remaining compatible with the characteristics of the ground coat and the metal support--expansion coefficient, firing temperature, and surface tension.

Many of the modern enamels for the chemical industry are composed of vitreous-crystalline materials which combine the advantages of corrosion protection obtained from conventional vitreous enamels, with improved resistance to thermal shock, derived from the presence of various crystal phases.

With these in mind, the studies were oriented in two major directions:

- 1) Find compositions of potentially crystallizable enamels, with suitable chemical resistance to both acids and alkalis, and with appropriate technical properties;
- 2) Increase thermal resistance by using precrystallized mill additives.

The formulated enamels consist of silicate glasses with 7-12 components. The compositions were selected with a view to creating a system of oxide components which will assure high chemical stability over the widest possible range of pH values.

The structures of conventional acid resistant enamels usually contain Al_2O_3 and TiO_2 [3] together with a large amount of SiO_2 [4,5].

The presence of Al_2O_3 in silicate glasses is known to improve their chemical resistance to attack by aqueous solutions [6,7]. This effect is due to the formation of AlO_4 groups bound by oxygens bridged by SiO_2 tetrahedrons, the cations of the alkali and alkali-earth metals which donate the necessary oxygens being maintained in the immediate vicinity of the AlO_4 groups to assure local electroneutrality. These cations will therefore be less free than in the absence of Al_2O_3 . The stability diagram of Al_2O_3 in aqueous solutions [8] shows that for the range of pH = 3.3-10.7, $\text{Al}(\text{OH})_3$ predominates and forms a passive, protective layer; for pH < 3.3, Al_2O_3 dissolves, with the Al^{3+} ions entering in solution, while AlO_2^- aluminate ions form for pH > 10.7; on the other hand, Al_2O_3 acts on the separation of vitreous microphases in glass by modifying the free energy of existing phases.

Titanium dioxide is thermodynamically stable in aqueous solutions throughout the pH range, so that the addition of TiO_2 increases the chemical resistance of homogeneous glasses; effects to the contrary are due to the separation of vitreous microphases or to the crystallization induced by the presence of TiO_2 , whose nucleation role is well known [9].

The need to formulate enamels which resist both acids and alkalis, has imposed the introduction of ZrO_2 into their compositions. It is known that even in low concentrations, ZrO_2 increases the chemical stability of glasses [10]. The exceptional alkali resistance of glasses which contain ZrO_2 is primarily due to the strength of the Si-O-Zr bond.

Cook and Paul [7] have shown that although the hydration of ZrO_2 is energetically favored, the ionic species ZrO_2^{2+} , Zr^{4+} and HZrO_3^- can appear only under pH=0 and above pH=17. That is why it is considered that under the usual range of pH, the surface of glasses containing ZrO_2 are stable, and what is more, that the presence of the latter creates high activation barriers for the diffusion of other ionic species through the glass.

The resistance of glasses to thermal shock is inversely proportional to their linear expansion coefficient [5]: the lower the coefficient, the higher the thermal resistance. On the other hand, the expansion coefficient of the enamel coat cannot be too low since it must match the expansion of the ground coat and metal. The expansion coefficient can be reduced by increasing the percent of the refractory oxides ZrO_2 , Al_2O_3 , and SiO_2 , characterized by negative or very small expansion coefficients, and which as we have shown, also provide high chemical stability. However, these oxides have the disadvantage of increasing the frit fabrication temperature, as well as the firing temperature of the enamel itself; all the components thus have to be judiciously balanced.

Based on these considerations, we have formulated enamel recipes in the fundamental oxide system $\text{R}_2\text{O}-\text{Al}_2\text{O}_3-\text{TiO}_2-\text{ZrO}_2-\text{SiO}_2$, where R designates the alkaline metals.

The expansion coefficients of frits were precalculated with Appen's [11] additive formula, thus optimizing the compositions so that the bulk thermal expansion (CDT) falls between 270 and $310 \cdot 10^{-7} \text{ grad}^{-1}$.

II. Experiments

The experiments were conducted in the laboratory, on micropilot lines, and as industrial tests.

1. Laboratory Experiments

Glasses for enamels were prepared in the laboratory from raw materials in the form of oxides and carbonates, blended in a planetary mill, and fused in sintered alumina crucibles, in a silica-brick electric furnace at temperatures between 1300 and 1350°C. The melt was cast into plates to determine alkali stability, rods for expansion measurements, and frits.

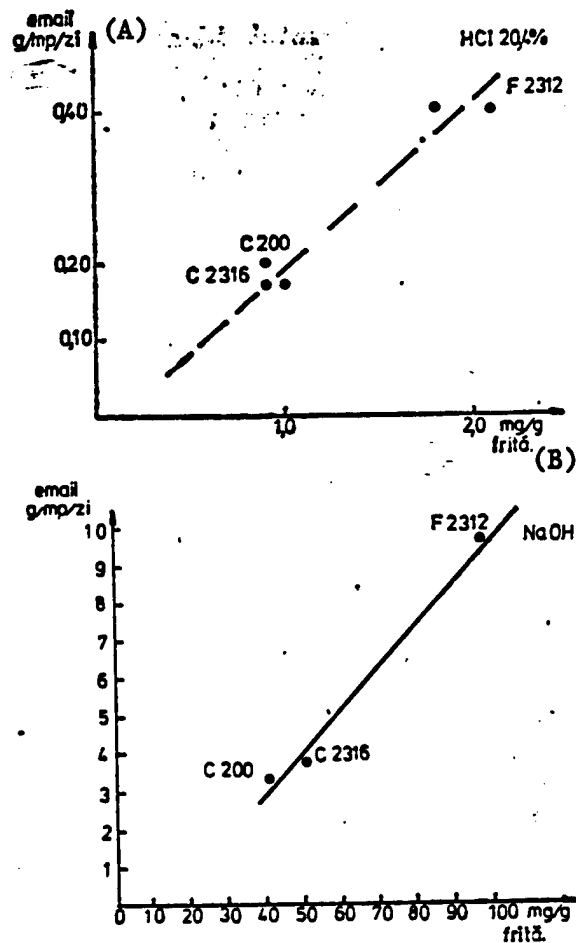

Figure 1. Correlation between chemical stability of frits and of corresponding enamels in domestic production.

Key: (A) Enamel, g/mp/day
(B) Frit

Chemical resistance to acids was determined with the method indicated by Andrews [5], measuring the weight loss of glass beads with a diameter of 0.84-0.60 mm after boiling in 20.4% HCl for five hours.

Chemical resistance to alkalis was determined by the STAS 598/2-1971 method, measuring the weight loss of glass platelets following boiling for three hours in a 1:1 mixture of 1N Na_2CO_3 and 1N NaOH.

Thermal expansion coefficients were measured with a Leitz dilatometer on glass rods drawn directly from the melt.

Table 1. Properties of glasses made in the laboratory and tested on a micropilot line.

Denumire sticlă (A)	CDT. 10 ⁻² /°C	Pierdere în HCl 20.40% mg/g (B)	Pierdere în NaOH + Na ₂ CO ₃ mg/dm ² (C)	Temperatură semiball. °C (D)
A	278	1.2	41	840
3 ⁸	279	1.1	50	880
3 ⁹	279	1.5	47	860
3 ¹⁰	270	2.0	42	870
3 ¹¹	276	2.1	31	820
3 ¹²	293	1.7	—	740
13	289	—	33	870
20	293	—	37	820

Key: (A) Glass type
 (B) Loss in 20.40% HCl, mg/g
 (C) Loss in NaOH + Na₂CO₃, mg/dm²
 (D) Semiball temperature, °C

Firing temperatures for enamel application were estimated from semiball temperatures, using a Carl Zeiss Jena MHO-2 high temperature microscope.

Since the frit is not used as such for metal enameling, but is ground with mill additives which to some extent modify its chemical composition and consequently its properties, we examined the possibility of determining limit values for the chemical stability of glasses, on whose basis we could make an early selection of compositions before testing the enamels on micropilot lines.

In this respect, we established during the first stage a correlation between the chemical stability of the frits and that of the corresponding enamels in current production.

Plots of the two sets of values (figure 1) show a linear relation between the corrosion behavior of frits and of the corresponding enamels, both in acid and alkaline media.

We thus established limit values for frit weight losses:

Up to 2 mg/g weight loss after boiling in HCl (corresponding to frit F 2312-Fagaras);

Less than 75 mg/dm² weight loss under alkaline attack, consistent with class I stability (corresponding to frits C 2316 and C 200-Fagaras).

The properties of glasses produced in the laboratory and selected for further research on a micropilot line, are shown in table 1.

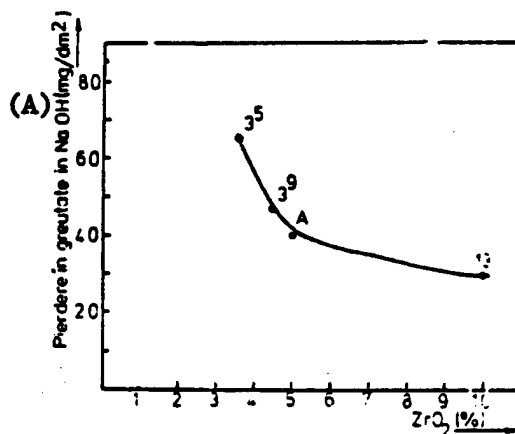

Figure 2. Chemical stability in alkalis as a function of ZrO_2 concentration in the composition of enamels.

Key: (A) Weight loss in NaOH

The chemical stability of these glasses in alkaline media strongly depends on the ZrO_2 concentration in the glass composition (figure 2), thus confirming the cited literature data on the role of ZrO_2 in reinforcing the silicate network.

2. Micropilot Line Tests

The enamels were produced on the micropilot line of the Fagaras Research Center for Anticorrosion Protection, Lacquers, and Paints, in accordance with existing technologies: weighing, dry mixing, melting in a rotary furnace at a temperature of 1300-1350 °C for 3-3.5 hours, and fritting in water. For application, the frit was damp ground in a ball mill according to conventional recipes, to a fineness of 0.8-1 °B.

The slurry was used to enamel standard ground-coated discs by spraying with compressed air guns at 2 atm. After drying, the discs were fired in an electric furnace at temperatures between 840 and 890 °C.

The characteristics of the enamels were determined according to STAS 10207 methods.

Micropilot line tests show that the formulated enamels have a very high resistance to thermal shock and alkaline corrosion, along with suitable acid chemical stability (table 2).

Table 2. Physicochemical properties of enamels produced on the micropilot line.

(A) Denumire email	Stabilitate chimică, (B) g/m ² , zi			Soc termic, °C (E)	Soc mecanic, N (F)	CDT, 10 ⁻⁷ /°C	Tempe- ratură, de ardere, °C (G)
	HCl soluție (C)	HCl vapori (D)	NaOH				
A	1,4	8,5	3,3	240	13,7	267	890
3 ⁸	1,7	7,9	3,6	220	13,7	267	860
3 ⁹	1,8	6,3	7,2	220	13,7	265	870
3 ¹⁰	—	—	—	—	—	260	870
3 ¹¹	0,9	4,9	7,5	230	13,7	271	860
3 ¹²	0,8	7,6	8,5	—	13,7	280	860
13	0,3	2,5	2,4	250	13,7	252	860

Key: (A) Enamel type
 (B) Chemical stability, g/m², day
 (C) HCl solution
 (D) HCl vapor
 (E) Thermal shock
 (F) Mechanical shock
 (G) Firing temperature

From a technologic standpoint, all experimental enamels containing a single frit showed more or less tendency to shrink during firing, as well as sensitivity to stress.

In order to optimize technical and material properties, the research was oriented toward the formulation of chemical enamels composed of frit mixtures and mill additives with complementary properties. We thus tested a mixture formed of two parts of frit A, for alkali and thermal shock resistance, and one part frit F 2312, which improved technologic characteristics (lower firing temperature and surface tension) and increased the expansion coefficient and acid stability. To further increase thermal shock resistance, a precrystallized material (denoted by C) was introduced as a mill additive.

This experimental microcrystalline enamel, A₂FC exhibited very good technical and material properties. Table 3 compares the parameters of the experimental enamel A₂FC and of enamel F 2312, which is currently used for chemical reactors.

3. Industrial Tests

The experimental enamel A₂FC was applied under industrial conditions at the Fagaras IUC (Enterprise for Chemical Equipment) on existing production lines. To obtain an unbroken film and adequate thickness, the industrial process consists of the successive application and firing of several coats. Components of heat exchangers and reaction vessels with various geometries were coated in this manner.

Table 3. Physicochemical properties of the experimental enamel A₂FC, compared to those of enamel F 2312.

(A) Denumire email	Stabilitate chimică. (B) g/m ² zi		(C) Rezistență la șoc termic, °C	(D) Temperatură de ardere, °C
	HCl (20.4%)	NaOH (1N)		
A ₂ FC	0,08	7,6	230	860
F 2312	0,44	9,0	150	820

Key: (A) Enamel type
 (B) Chemical stability, g/m² day
 (C) Thermal shock resistance, °C
 (D) Firing temperature, °C

The A₂FC enamel proved to be compatible with the AH 21 metal and G 1500 ground coat used at the Fagaras IUC in the enamelling process.

The continuity of coatings on parts was tested at a breakthrough voltage of 40,000 V.

The industrial tests showed that this enamel reduces the number of application-firing cycles, representing a corresponding savings of raw materials, manpower, and energy.

III. Conclusions

Glass compositions that are highly resistant to both alkalis and acids were prepared for chemical enamels; these glasses are part of the fundamental oxide system $R_2O \cdot Al_2O_3 \cdot TiO_2 \cdot ZrO_2 \cdot SiO_2$ (where R = an alkaline metal).

Vitro-crystalline enamels were created from these glasses, composed of one or more frits and with mill additives; they exhibit remarkable thermal stabilities ($\Delta T = 230-250$ °C) together with high resistance to alkalis and acids.

Of the industrially produced enamels, the A₂FC enamel (composed of frits and a precrystallized mill additive) demonstrated improved technical and material properties.

The application of the A₂FC enamel reduces the number of enamel coatings during processing, leading to corresponding savings of raw materials and energy.

REFERENCES

1. ***Catalog I.U.C.--Fagaras,,Conducte si piese din otel emailat."
2. Usakov, D.F., STEKLO I KERAMIKA, No 8, 1971, p 25.
3. Varghin, V.V., STEKLO I KERAMIKA, No 8, 1962 p 35.
4. Petzold, A., "Email," VEB Verlag Technik, Berlin 1955.
5. Andrews, A., "Porcelain Enamels," Garrard Press, Illinois, 1961.
6. Volf, M.B., "Technical Glasses," Ed. Pitman I., Ltd. London, 1961.
7. Cook, D. and Paul, A., TRANS. BR. CERAM. SOC., 77, 1978, p 77.
8. Paul A., J. MAT. SCI., 12, 1977, p 2246.
9. Jelli, A., SILICATES IND. 5, 1974, p 141.
10. Pavluskin, N.M., Sentiorin, G.G., and Hodanovskaia, P.R., "Praktika po tehnologii stekla i sitallov," Izd. literat. po stroitelstvu, Moscow, 1970.

11,023

CSO: 2702/2

ACUTE TOXICITY OF BUTANOL, MONO-, DI-, AND TRIBUTYLAMINE

Bucharest REVISTA DE CHIMIE in Romanian No 7, Jul 85 pp 667-670

[Article by Maria Ciugudeanu, Silvia Gabor, Gabriela Ivanescu, Cluj-Napoca Institute for Hygiene and Public Health, Maria Gocan, Cluj-Napoca Medico-Pharmaceutic Institute, and Anton Buzas, Medias Institute for Research on Auxiliary Organic Products]

[Text] Experimental studies were conducted on the acute toxicity of butanol, mono-, di-, and tributylamine. The results obtained, and in particular, the value of LD₅₀, lead to a classification of the compounds into various toxicity groups. According to the data, mono- and dibutylamine fall in the category of very toxic compounds (50-500 mg/kg), while tributylamine and butanol fall in the category of moderately toxic compounds (0.5-5 g/kg).

Butanol and butylamine compounds are widely used in the chemical, pharmaceutical, and cosmetic industries, in plastics, pesticides, and in the preparation of special soaps and dyes.

The basicity and high volatility of these compounds causes strong reactions in live organisms with which they come in contact.

The literature data, which is rather meager regarding the action of these compounds on live organisms, discloses the following effects:

a) In man, butylamines cause strong cutaneous and mucous irritation, headache, and pulmonary edema [1]; intravenous injection in anesthetized dogs has caused a drop in blood pressure, suggesting a mechanism of peripheral ganglion blockage [2] with onset of a depressive effect;

b) In man, butanol also causes irritation of the upper respiratory track, dermatitis, as well as hepatic and renal necrosis [1]; in experimental animals, it has created bronchopulmonary irritations with hepatic and renal affections, and fatty degeneration of the liver [3].

Literature data about the acute toxicity of these compounds establishes the lethal dose for n-butyl alcohol orally administered to rats, at 4360 mg/kg; the lethal dose for subcutaneous administration of n-butyl alcohol in mice is 5000 mg/kg, and in dogs 2000-2300 mg/kg [4]; other sources give LD₅₀ values of 3800 mg/kg [5].

Oral administration of monobutylamine in rats resulted in an LD₅₀ of 500 mg/kg [6], while others quote LD₅₀ values between 430 and 450 mg/kg [7].

Intragastric administration of dibutylamine has produced an LD₅₀ of 290 mg/kg for mice, 300 mg/kg for rats, and 230 mg/kg for guinea pigs [7].

LD₅₀ values of 540 mg/kg for rats and 250 mg/kg for rabbits [8] are cited for tributylamine.

The aim of this work was to obtain new data on the acute toxicity limits of butanol, mono-, di-, and tributylamine, compounds synthesized at the Medias Institute for Research on Auxiliary Organic Products.

Materials and Methods

For acute experimental tests we used mature Wistar-breed white rats, with a weight of 140-200 g, both sexes, 10 animals/dose.

Preliminary testing of the compounds in question was carried out on lots of 3-5 animals which were given various dilutions (mg/kg body weight) of the compounds (8, 4, 10, 12, 50, and 70 percent), to experimentally determine the minimum dosage limit at which all animals survive (LD₀) and the maximum dosage limit at which all animals die (LD₁₀₀). After establishing the working dilution and the values of LD₀ and LD₁₀₀, we undertook the actual experiment to determine LD₅₀, administering several doses of the selected dilution. The dilutions were made in commercial vegetal oil to avoid possible hydrolysis of the compounds, and to obtain the best possible homogeneization of the mixture.

We formed lots of 10 animals of appropriate weight, which were given through an intragastric catheter, a single dose of various amounts--in mg/kg of body weight--of the following dilutions: 8.4 percent dilution for mono- and dibutylamine, 12 percent for tributylamine, and 70 percent for butanol. Lastly, several doses were administered of each dilution of the respective compound [7-12]. The same channel of administration was used, as well as the most uniform possible working conditions. The effects of the toxin were observed for at least two weeks, recording lethality at 24 h, 7 days, and 14 days. The 50 percent lethal dose was considered the one which caused the death of one-half of the animals 7 days after the compound was administered.

Results and Discussion

The clinical signs of acute intoxication were quite varied, depending on the chemical compound. Monobutylamine for instance, provoked slight agitation in the animals, followed by growing excitement, ataxic gait, decubitus, tremors, convulsions, and tetany, with death beginning approximately 30 minutes after administration of 400-600 mg/kg doses. In autopsy, the animals showed congestion of internal organs, sometimes internal and external (nose, mouth) bleeding, with the formation of a clear thrombus growing on the aorta at the exit from the heart.

The administration of dibutylamine also provoked slight agitation, followed by very high excitability, ataxic gait, lateral decubitus, head rocking, tremors followed by paresis and paralysis of the animals, with death beginning approximately 20-30 minutes after doses much lighter than those used with monobutylamine.

The administration of tributylamine caused the same symptoms as monobutylamine, except that some animals underwent repeated cycles of excitation after a period of stillness, with death occurring much later for larger doses (600-900 mg/kg). In autopsy, the animals treated with di- and tributylamine showed the same macroscopic features as those treated with monobutylamine.

After administration of butanol, the animals became slightly agitated, followed by increasingly slow locomotive activity, lateral decubitus, dyspnea, with death after a longer time, especially for large doses. Animals injected with butanol in smaller doses manifested slow locomotive activity and lateral decubitus at first, and recovery to normal behavior after some time.

All these clinical manifestations as a function of administered dose, reflect disturbances of the central nervous system, the ataxic gait indicating lesions of nerve channels or of motion-coordination nerve centers, while the lateral decubitus can be ascribed to the narcotic action of the compound on the cerebellum.

The results obtained for lot lethality 7 days after toxin administration were used to statistically calculate LD_{50} by the probit method [9]. The straight line obtained by linear regression establishes a correlation between the two figures, the logarithm of the dose (abscissa) and probits (ordinate). The dose-effect plots obtained for the four tested compounds are shown in figures 1-8.

The results from acute investigations of single peroral administrations of mono-, di-, and tributylamine, and of butanol, are shown in table 1. The table indicates greater sensitivity to dibutylamine on the part of male rats compared to females.

The lethal dose cannot be considered as an absolute value, a reason for which safety limits must also be known for more precise estimates. Using the values for LD_{16} and LD_{84} , the nomographic method [10] was used to calculate upper and lower safety limits for LD_{50} .

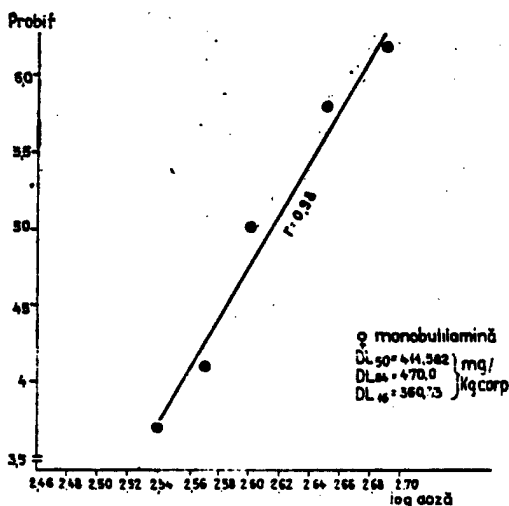

Fig. 1. DL_{50} calculat cu metoda probit.

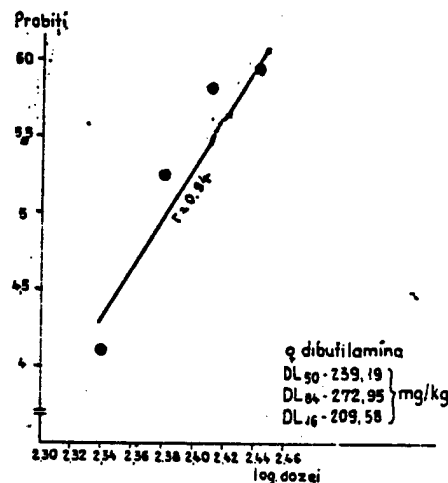

Fig. 3. DL_{50} calculat cu metoda probit.

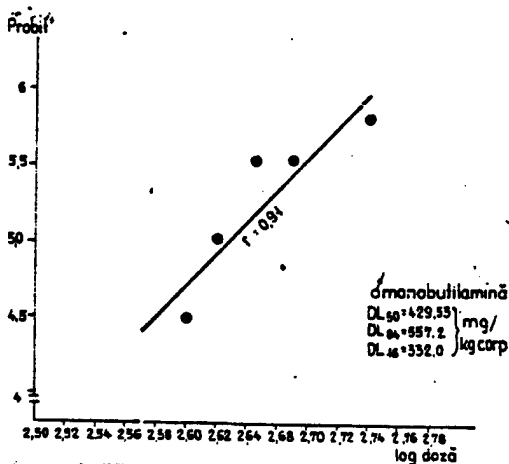

Fig. 2. DL_{50} calculat cu metoda probit.

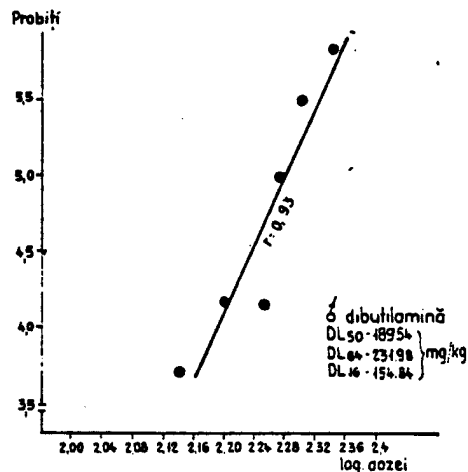

Fig. 4. DL_{50} calculat cu metoda probit.

Figures 1-4. LD_{50} calculated by the probit method.

Consistent with the classification of chemical substance toxicity in terms of LD_{50} [11,13], monobutylamine and dibutylamine fall in the category of very toxic substances (50-500 mg/kg), while tributylamine and butanol fall in the category of moderately toxic compounds (500-5000 mg/kg).

Anatomic pathology investigations of the liver, kidneys, and heart 14 days after injection with mono- and dibutylamine do not reveal significant changes in their structure, compared to the control lot. The administration of tributylamine (400 mg/kg) caused hepatic stasis throughout the vascular system, as well as hydroprotidic dystrophy, with peritubular stasis in the kidneys. An anatomic pathology study of the liver, kidneys, and myocardium 14 days after administration of single doses of butanol (3000-3800 mg/kg) discloses changes in these organs. In the kidneys, in the glomeruli area, in

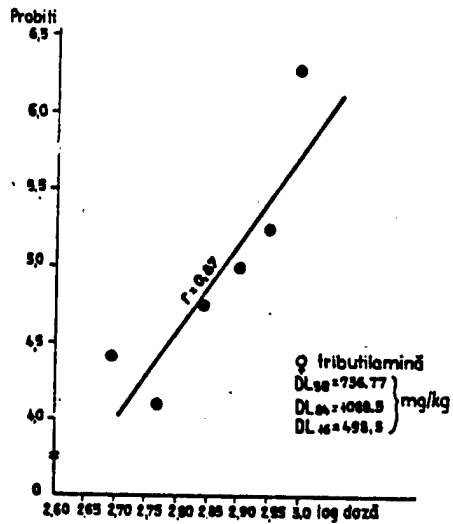

Fig. 5. DL_{50} calculat cu metoda probit.

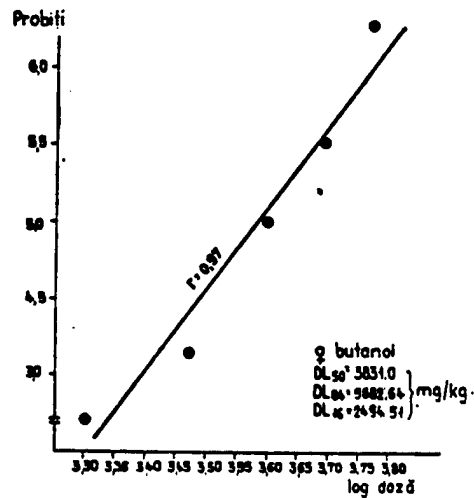

Fig. 7. DL_{50} calculat cu metoda probit.

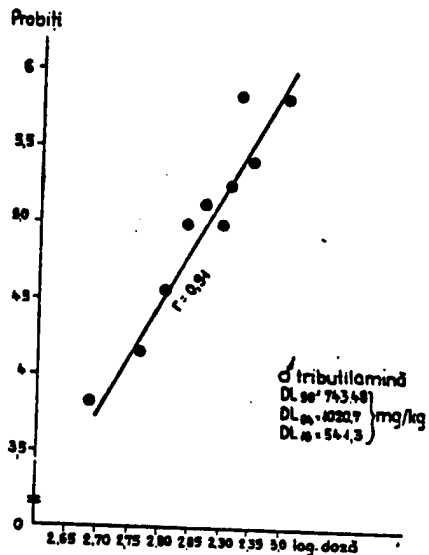

Fig. 6. DL_{50} calculat cu metoda probit.

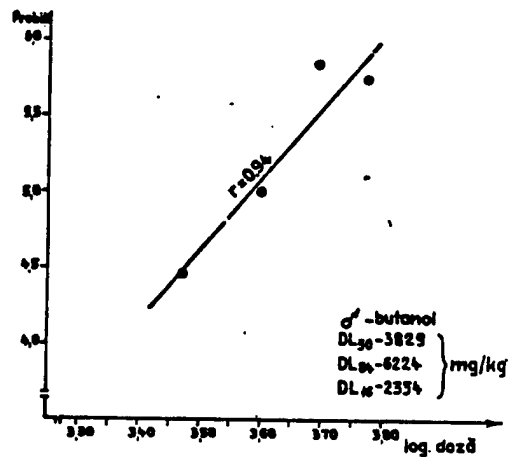

Fig. 8. DL_{50} calculat cu metoda probit.

Figures 5-8. LD_{50} calculated by the probit method.

the subcapsular space, we find a lightly colored material of hyalin appearance. The vascular ball, of reduced dimension, has fallen in the glomerulus cavity. Surrounding it, the tubes of the cortical area show degenerative and necrotic lesions, with the tubes grouped in a zone of triangular aspect, characteristic of a preinfarctus, raising the question of a mesangium lesion, the so-called glomerular opsolescence [as published]. In the liver, we observed a stasis of the entire portal vascular, interlobular, sinusoidal system, and of the centrolobular vein. The hepatocytes show reduced reversible hydroprotidic dystrophy, with nuclei of normal appearance. In the myocardium as well, we find reduced dystrophic lesions in the fibers, such that butanol is shown to have a toxic action on this organ as well.

Table 1. Acute toxicity of mono-, di-, and tributylamine, and of butanol, for intragastric administration in rats.

Compusul	Sex	(B) Administrare unică per oral, mg/kg				
		DL ₅₀	DL ₁₀	DL ₅	(C) limite de siguranță* (F)	
					(E) inferioară	(E) superioară
Monobutilamină	(A) femele	411	360	470	390	434
	masculi	430	332	557	387	477
Dibutilamină	femele	239	209	272	226	252
	masculi	189	154	231	202	177
Tributilamină	femele	736	498	1 088	635	854
	masculi	743	541	1 020	663	832
Butanol	femele	3 831	2 494	5 882	3 219	4 559
	masculi	3 829	2 354	6 224	3 014	4 862

Key: (A) Females, males
 (B) Single peroral administration, mg/kg
 (C) Safety limits
 (D) Upper
 (E) Lower
 (F) Data corresponding to LD₅₀ and LD₁₀ was used to calculate safety limits (statistical) using the monographic method [10]

Conclusions

Experimental results for acute toxicity, namely the value of LD₅₀, make it possible to classify mono- and dibutylamine as very toxic substances (50-500 mg/kg), and tributylamine and butanol as moderately toxic compounds (500-5000 mg/kg).

Primary among the major toxic effects is a perturbation of the nervous system activity, with subsequent effects on such internal organs as the kidneys, the liver, and the myocardium.

REFERENCES

1. Plunkett, E.R., "Handbook Industrial Toxicology," Chemical Publishing Co., I.N.C., New York, 1976, p 70.
2. Stanton, H.C. and Woodhouse, F.H., J. PHARMACOL. EXPTL. THER., 128, 1960, p 233.
3. ***Fiche Toxicologique nr. 80, Alcohol butylique, C. Morel, A. Cavigneaux, M.J.C., Protois, I.N.R.S., Paris, 1974.
4. Galfa, V. and Preda, N., Toxicologia unor solvenți, Ministerul Industriei Chimice, 1976. p 71.

5. Quinot, E., Moncelon, B., and Millards, M., Substances toxiques dans l'air, Essai de détermination d'une valeur limite calculée d'exposition. Chaiers de notes documentaires nr. 97. 4, I.N.R.S., Paris 1978, p 547.
6. Spector, S.W., "Handbook of Toxicology," I, Philadelphia and London, 1956, p 52.
7. Izmerov, N.F., Sanotskiy, I.V., and Sidorov, K.K., "Toxicometric parameters of industrial toxic chemicals under single exposure," United Nations Environment Programme, Centre of International Projects. G.K.N.T., Moscow, 1982, p 43.
8. *** Fișe toxicologice, Ministerul Industriei Chimice, 1981.
9. Popa, L., Ariesan, M., and Popa, L. Lucrari practice de toxicologie, litografiat I.M.F., Cluj-Napoca, 1980.
10. Velea, S., "Calculul nomografic in practica medicala si farmaceutica," Ed. Medicala, Bucuresti, 1966, p 94.
11. Zbinden, G. and Flury-Roversi, M., ARCH TOXICOL., 47, 1981, p 77.
12. Rowan, A., ACTA PHARMACOL, TOXICOL., 52, 1983, p 52.
13. Gosselin, R.E., Hodge, H.C., Smith, R.R., and Gleason, M.N., "Clinical Toxicology of Commercial Products, Acute Poisoning," IV ed., Williams and Wilkins Co., Baltimore, 1976.

Received on 27 June 1984

11,023

CSO: 2702/2

ROMANIA

ACHIEVEMENTS, PROSPECTS FOR MOTRU-JILT COAL FIELD

Bucharest MINE, PETROL SI GAZE in Romanian Vol 36 Aug 85 pp 379-382

[Article by N. Alecu, director general of the Motru Mining Combine]

[Text] The 41st anniversary of the socialist, national, antifascist, and anti-imperialist revolution, the 56th anniversary of the mine struggles at Lupeni, and the 25th anniversary of the start of mining operations in the Motru-Jilt basin, provide us with an opportunity to appreciate the importance of the long-term strategy for coal production development in Romania.

Given its share in the structure of resources used to produce electric and thermal power, coal is exceptionally important among the country's total energy resources.

The Gorj coal basin represents the major source of coal used for generating thermoelectric power at the Rogojelu, Turceni, and Isalnita plants, providing nearly 70 percent of the country's coal production, to which the Motru Mining Combine (CM) contributes 40 percent.

The first geological searches in the Olteni Subcarpathic region were conducted by geologists Sabba Stefanescu and Grigore Cobalcescu, who determined the geological age of the sedimentary formations.

Geologist Ionescu-Argetoia, studying the lignite outcroppings in the Motru-Matasari-Rosia de Jiu zone, determined the Levantine age of the coal-bearing formation.

During 1945-1946, geologists V. Onescu and T. Popa confirmed the Levantine age of the marl and sand mixture, and the Dacian age of the productive formation; lastly, geologist D. Ciric, also determined a limit of the Dacian-Levantine age at the base of coal bed VII, using paleontologic arguments.

True geologic searching was started in 1953 by the State Enterprise for Mining Exploration, and the first hydrogeologic research began in 1958. Concurrent with the core borings necessary for planning future mines and quarries, the first pilot mine projects were undertaken in 1960 at Horasti and Plostina.

During 1960-1965, mining operations at Horasti, Plostina, and Leurda expanded, so that beginning in 1965 it could be said that a mining activity had truly started in the Motru basin. The coal deposit consists of 19 beds, only five of which, XII, X, VII, VI, and V, are exploited underground; bed V is adjacent to the hydrostatic level. Bed thicknesses range from 2.5-8 m; the beds are sloped as much as 5 degrees, and have few tectonic discontinuities, the largest of them being bed X.

The Motru CM has three mining enterprises: Motru, predominantly underground, Lupoia, operating as a quarry, and Jilt, with both underground and quarry activities.

Underground, lignite is extracted with complex mechanized cutting, and above ground it is dug from quarries equipped with excavation-transportation-dumping systems, using bucket wheels, high capacity transporters, and dumping installations.

Lignite extraction by units under the Motru CM jurisdiction has developed rapidly from 41,000 tons in 1962, to 13 million tons in 1984; as a whole, over 125 million tons of lignite were extracted during a period of nearly 25 years. It should be pointed out that more than 50 percent of the total production since the beginning of activities in the basin was extracted during the current five-year plan.

On the 25th anniversary of the start of mining operations in the Motru basin, we need to cast a backward glance at the first years of activity, years during which digging for opening, preparation, and exploitation began to be mechanized. The first mining technology record--cutting 601 m/month with a machine--was achieved at the Horasti mine in 1965. Metal pole supports and scraper transportation were introduced at the same time; the production was transported on rubber covered conveyors or in cars drawn by locomotives, the latter method, which in fact was used to open the Leurda and Plostina mines, being supplanted by the first.

In order to introduce cutting mechanization, it was necessary to start an extensive research program to select the equipment for comprehensive mechanization of cutting operations.

The first OMKT-IV mechanized installation was introduced in 1965 at the Horasti mine, and in 1966 at Leurda.

The first Romanian-produced mechanized installation, the CMA-0, was conceived, designed, and built on the basis of exploitation observations, and was then upgraded to models CMA-1, CMA-2, and CMA-2M.

The actions taken to hasten the development of coal production and mechanization have naturally led to such mining technology records as:

Cutting 250 m of gallery with an opening machine, and supporting 200 m of continuous arched walls, by a comprehensive brigade (July 1967, Lupoia mine);

Drilling 158 m/month in a stope equipped with a mechanized cutting-loading-support installation (July 1969, Plostina mine);

Preliminary machine cutting of 804 m in one month (1970, Plostina mine);

[Illegible in text] of preliminary gallery (April 1974, Lupoaia mine);

Machine cutting 1100 m of preliminary gallery with a cross section of 7.4 sq-m, [misprint in text] 50 m long and 12 sq-m in cross section (June 1974, Lupoaia mine);

Drilling 242 m per month with a mechanized cutting machine (June 1974, Plostina mine);

Drilling 162 m per month in a stope with an artificial roof (April 1980, Lupoaia mine).

During the entire time since the introduction of the first mechanized installation, a number of improvements were made in the rate of drilling and production in stopes, such as:

Mechanized support at intersections of stopes with material transportation galleries;

Mechanized support at intersections of stopes with collection galleries;

Cutting-wall length increased to 130 m;

Using two machines in a single excavation;

Improved hydraulic support system;

Created a new type of cutting machine drum and scrapers for maximum output and lower electrical consumption;

Created a machine plow for total loading of material;

Provided shields for cutting machines;

Built a stope ventilation system for minimizing dust, knowing that water spray creates difficulties for production transportation;

Built crushers mounted on collection gallery transporters to size the coal for easier conveyor transportation.

Outstanding achievements have also been obtained in quarries equipped with bucket wheel excavators, units with large production capabilities; four quarries of this type are currently in operation at Lupoaia, Jilt-Sud, Jilt-Nord, and Rosiuta.

The development of lignite production in this part of the country, as part of the party's policy for equal distribution of means of production, has had a decisive influence on a better standard of living.

The mining town Motru, with 23,000 inhabitants, is a modern town which in addition to 5300 apartments, has a school complex, a hospital, clinic, cultural center, movie house, child care centers, kindergartens, schools, and so on. Added to the above are the picturesque trails and recreation areas in the town's immediate vicinity.

Large construction projects are underway in the Matasari zone to provide sociocultural facilities for workers in coal mines and quarries.

Responding to the constant concern shown by our party and state for the basin's economic and social development, the miners and other workers in the Motru-Jilt basin are determined to devote all their efforts to fulfill the program for increased coal production.

11,023

CSO: 2702/6

ROMANIA

ACHIEVEMENTS, OUTLOOK FOR NON-METALLIC SUBSTANCES

Bucharest MINE, PETROL SI GAZE in Romanian Vol 36 Aug 85 pp 379-382

[Article by C. Smarandescu, director general of the Bucharest Central for Salts and Non-Metallic Substances]

[Text] The development of the national economy resulting from the wise policy of the RCP and the Romanian state, implies the development of the country's technical-material basis.

In this respect, the extraction industry plays an overwhelming role in assuring the base of mineral raw materials. Among the sectors of the extractive mining industry, the non-metallic substance sector is involved in the production of material goods in nearly all branches of the national economy; the units of the Central for Salts and Non-metallic Substances (CSN) is currently supplying 23 groups of products with more than 120 types of materials.

The development of the non-metallic substance sector underwent a large growth following the Ninth Congress of the RCP, achieving in 1985 production levels that are 5-7 times those of 1965.

Significant increases exist in the production of processed quartz, processed kaolin, chalk, dolomite, processed bentonite, solid and solution salt, graphite, sands for casting and the glass industry, as well as limestone for the steel, chemical, food, and other industries.

This development was made possible by efforts to discover deposits of non-metallic substances, establish technologies for their exploitation, and allocating a significant investment volume to open new mines and quarries, and to build processing installations. During the 1981-1985 period alone, 2.7 billion lei were assigned to develop production facilities and build new objectives.

At present, CSN exploits 59 deposits in 20 counties through its mining units.

The application of improved processing technologies has led to high quality products, competitive with imported ones, and fully satisfying to users.

The attention and efforts of specialists in this field are materialized in new products, some of them advanced ones, such as:

Micronized and activated bentonite for drilling fluids, casting binders for the food industry, and so on;

Chemically processed, calcined, and micronized kaolins for electric cables, fillers, chemical products, and polishing pastes;

Kaolin that is 82-84 percent white for the paper industry;

Sodium and potash for the glass industry, fine ceramics, construction ceramics, sanitary porcelain, and so on;

Quartz wool for packing induction electric ovens; acid packing wool for casting pots and furnace cupolas;

Granulated dolomite for the steel and chemical industries, and granulated ground dolomite for the glass industry;

Restored quartz and quartzite for iron alloys and for elementary silicon;

Graphite varieties containing 80-95 percent C for various industrial uses;

Graphite based refractory pastes and paints;

Processed volcanic tufa for the chemical industry;

Various types of diatomite, and so on.

The accomplishments obtained in developing the nonmetallic substance branch were due not only to the efforts made by workers and specialized personnel in units, but also to the significant contribution of specialists at the Cluj-Napoca Institute for Research and Design in the Mining of Nonmetallic Substances (ICPMSN), established in 1974, whose activity is focused on techniques for the extraction, mechanical preparation, and chemical processing of mineral substances, on the adoption of new preparation and exploitation equipment, and on the design of new investment objectives. In collaboration with specialists in units and the central, the institute's specialists have found efficient solutions for improved exploitation of nonmetallic substance deposits. They researched, developed, and implemented with satisfactory production results the following technologies:

Flotation of Muntele Rece feldspar;

Chemical processing of kaolin;

Production of high quality graphite varieties;

Preparation of kaolinized rhyolite at Parva;

Production of support granules for pesticides from Adamclisi diatomite;

Wet preparation of refractory clays from Suncuius;

Salt exploitation in small rooms with square pillars;

Introduction of technical preparation equipment (rubber hydroblenders, equipment for micronizing and pneumatic classification of bentonite, equipment for hydraulic classification of quartz sands, filter presses, and so on).

In recent years, the technical research activity has been oriented toward the production of high purity nonmetallic products to replace imported ones, such as: calcined, micronized, chemically treated kaolins for high voltage electric cables, precision casting, and PVC fabrication; diatomite for filtering food products, wine, beer, vegetable oils, starch, and glucose; organophilized clays and bentonites for enamels, settling prevention in lacquers and paints, and very deep drilling; high purity graphite for the electronic industry, forges, chemical products, pencils, and vanadium catalysts; support tufas for pesticides and other applications; materials for abrasive and polishing pastes; as well as talcum for pharmaceutical and cosmetic products.

In order to supply the national economy with such products, we have started to install low tonnage production lines at the Cluj-Napoca ICPMSN, and build new objectives at mining units in Cluj, Rimnicu Vilcea, Harghita, Dobrogea, Orsova, and Ocna Mures.

During the 1986-1990 five-year plan, substantial production growth is planned for the majority of nonmetallic substances, consistent with the development of industry branches that use these substances.

Also during the next five-year plan, we will introduce into the economy new deposits of nonmetallic substances, such as diatomite at Filia, brucite at Budureasa, quartz sands at Caraorman, steel limestone at Baneasa, salt at Turda, and so on.

For the exploitation of these deposits, the 1986-1990 five-year plan has allocated funds of 3.7 billion lei, which represents a 37 percent increase over the present five-year plan. All the new objectives will be built on the basis of domestic technologies, to obtain good quality products, new varieties, and to exploit them with higher efficiency.

We are firmly convinced that through the development of the nonmetallic substance sector we are contributing to the development of the entire national economy, thus helping to implement the Directives of the 13th Congress of the RCP.

Mobilized by the call of the party and of its secretary general, Nicolae Ceausescu, to increase our contribution to the development of the national economy in the demanding spirit stamped on research and technical engineering activities by academy member, doctor, engineer, Elena Nicolae Ceausescu, we will intensify our activities to fulfill the high responsibility tasks we must complete to discover and exploit deposits of nonmetallic substances.

11,023
CSO: 2702/6

ROMANIA

DEVELOPMENT OF HARDCOAL MINING, UTILIZATION IN VALEA JIULUI

Bucharest MINE, PETROL SI GAZE in Romanian Vol 36 Aug 85 pp 383-384

[Article by I. Costescu, director general of Valea Jiului Mining Combine]

[Text] A primordial requirement for Romania's socioeconomic development is sustained growth in the branches that provide raw materials and energy resources. Consistent with the Priority Program Regarding the Development of the Energy and Mineral Raw Materials Base in 1985 and During the 1986-1990 Five-Year Plan, the Valea Jiului Mining Combine (CM) has assumed special tasks for increasing the production of power-production and cokeable coal. During this year, the mining units in the Valea Jiului coal basin are expected to extract more than 13 million tons of coal, and production is expected to grow by 60-65 percent during the 1986-1990 five-year plan.

Considering the contribution of the basin's mines to the country's energy balance, significant funds have been allocated during every five-year plan to develop and modernize these mines and preparation plants, to implement new technologies, and to expand mechanization and automation.

The volume of investments allocated during the 1965-1985 period exceeds 20 billion lei, which were used to expand existing production capabilities and build new ones, acquire new modern and high productivity tooling, machines, and installations, train and instruct personnel, and constantly improve the working and living conditions of the workers.

During the last 20 years, our coal industry, and its production and technical processes, have been very thoroughly upgraded. New mining units, such as Livezeni, Barbateni, and Cimpu lui Neag, which are undergoing extensive development, were opened alongside existing ones, and others, such as Petrila-Sud, Lupeni-Sud, and Valea de Brazi, are being opened and developed.

During the current five-year plan about 80 km of mining and opening operations, and 275 km of preparation work will be executed, achievements made possible by the sustained fulfillment of the program to endow and mechanize the basin's mines.

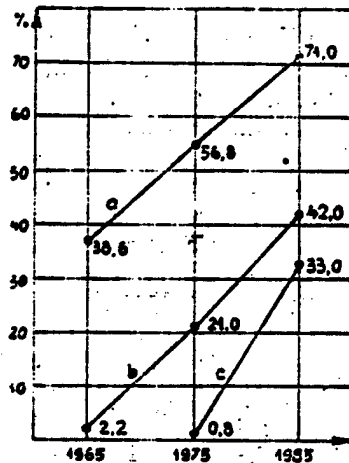

Figure 1. Mechanization in front cutting
 (a) Total front cutting
 (b) Mechanical front cutting
 (c) Front cutting with mechanized machines

In recent years and currently, the degree of mechanization in Valea Jiului mines is undergoing strong growth, and continued improvements are expected based on the results obtained. The combine's mining units have 48 mechanized cutting machines, 30 of them manufactured in Romania, 48 opening machines, as well as many other loading and transportation installations. A program for modern general underground transportation has introduced continuous hauling with buffer transfer stations, as well as multiple cable skip hoists operating automatically. Attention is currently being devoted to mechanizing the transportation of equipment to work sites by containerizing and palletizing it at surface storage areas.

The mining enterprises in Valea Jiului basin have been equipped with remote gas detectors and gas removal stations, for more effective underground work protection and safety; remote gas detectors are in operation at every mining enterprise.

The value of the technical fixed assets at Valea Jiului mining units exceeds 15 billion lei, being nearly six times larger than in 1965.

In order to assure the planned rate of production growth, it was necessary during this period to significantly modify both the share of participation in exploitation methods, and especially the technologies being used.

A major concern is the application and expansion of new exploitation technologies. Intensive action is taken to use CMA-5H very high machines wherever conditions allow exploitation in horizontal seams with reinforced roofs, and to modernize and mechanize the support technology for opening and

preparation operations. Frontal wall cutting has been expanded, and at the No 3 main bed, increasingly broad use is made of short front and reinforced roof exploitation method, which will almost fully replace the room and pillar approach.

In 1985, the degree of mechanization of coal extraction will reach 42.0 percent of the total production at stopes, and the production obtained with mechanized cutting machines will be 33.0 percent (figure 1).

Significant achievements were also obtained in recent years in digging and supporting opening and preparation mining operations (figure 2). Mechanized operations and improved working techniques in these phases was necessary both to reduce physical effort, and to assure assigned production volumes, considering that more than 70 km of opening and preparation operations are carried out every year.

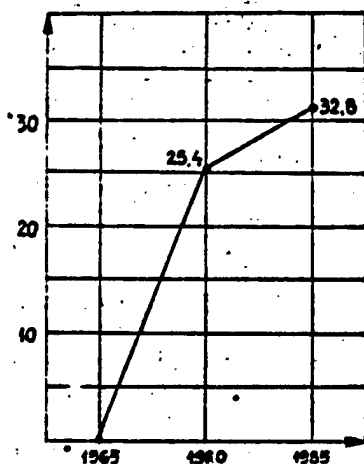

Figure 2. Mechanization of horizontal cutting in mining operations

During this period, we have finalized and established new technologies for mining operations and maintaining them in exploited areas, for using mechanically installed heavy prefabricated concrete supports, supporting galleries with metal supports made of heavy weight SG-29 cross sections, improving the combination of support elements, and mechanizing the installation of metal arches.

Significant achievements were also obtained in processing and preparing the extracted coal. Together with expanding and modernizing existing installations, we have built a preparation facility at Coroiesti, and we are currently building the future facilities at Livezeni and Uricani. Sustained and systematic efforts are being made to build separate lines for waste and coal, and for normal operation of presorting installations, a notable technical achievement in coal mining.

The increasingly advanced mechanization constantly changes the mining activities in the Valea Jiului basin; management and control become more complex under these circumstances. Progress is being made to assure centralized control and supervision of underground operations, and to build the parts of a modern system for automatic scheduling of mining and preparation processes.

The necessary personnel is trained in our own schools: industrial high schools, professional schools, qualification and foreman schools, and upgrading courses.

A significant portion of the production growth will be obtained by placing in operation new production capabilities and through higher labor productivity, particularly by raising the intensive and extensive indicators of high efficiency installations, through mechanized cutting and opening machines, and through better organization of labor and higher qualification of the personnel.

For the future we are planning devote priority to work safety problems, to research into dangerous underground toxins, such as dynamic level and reduction of dust concentrations, biologic effects, prevention of professional diseases, and improved recovery of the work force. In this respect, we will generalize the use of remote monitoring of ventilation and dangerous gases in mines, expand local and central gas removal from coal beds, modernize electrical equipment to improve safety, improve safety in deposits by expanding modern prevention procedures in zones likely to self ignite.

The achievements and the levels we have reached are due in all respects to our party and state leadership, and personally to the secretary general of the party, president of our nation and honorable miner, Nicolae Ceausescu, who has demonstrated truly parental care toward miners and other workers, and who has done everything possible so that they might enjoy the benefits of socialism, for which we extend our warmest gratitude and assure him of our full devotion and revolutionary attachment, and of our firm determination to make our maximum contribution to fulfilling the tasks that we have been assigned by the programs adopted by the 13th Party Congress, for the flowering of material and cultural wellbeing for the Romanian people.

11,023

CSO: 2702/6

ROMANIA

INCREASED ACHIEVEMENT, UTILIZATION IN MINING ANTICIPATED

Bucharest MINE, PETROL SI GAZE in Romanian Vol 36 Aug 85 pp 385-386

[Article by D. Condrache, director general of the Ploiesti Mining Combine]

[Text] To implement the tasks outlined for the mining industry by the 12th and 13th Party Congresses, the workers at the Ploiesti Mining Combine (MC) are firmly determined to improve lignite exploitation technologies and increase extraction capabilities, so as to fulfill the 1985 plan in an exemplary manner, and to achieve the production levels forecast for 1986-1990.

The determining factor in accomplishing these tasks is the degree of mechanization in frontal cutting as well as in opening and preparation work.

Although the geological conditions of the combine's mines are difficult because work faces are under the hydrostatic level, and in zones that are tectonized and heavily tilted, the present mechanization of extraction in stopes is over 48 percent, and more than 26 percent in drilling. To achieve their tasks at a constantly growing pace, specialists in the combine, together with researchers and designers have focused their attention on the creation of new technologies and tooling for the specific conditions of the deposits being exploited, so as to increase the mechanization of underground operations.

In order to assure greater mechanization in stopes, new technologies had to be developed to design mechanized cutting machines that would operate on slopes greater than 15 degrees.

In close collaboration with the Craiova Institute for Lignite Mining Research, Technical Engineering, and Design, we will test during this year part of a new mechanized machine designed by researchers, which will ultimately be used for cutting in heavily sloped beds that cannot be mechanized at present.

Similarly, in order to increase mechanization in drilling operations, particularly on slopes and in areas with water infiltration, which cannot be mechanized at present, we will test a rail-mounted machine for digging, loading, and support.

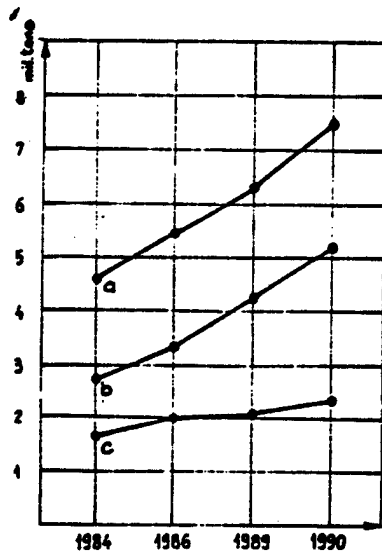

Figure 1. Lignite production in 1984 and the 1986-1990 five-year plan
 (a) Total production
 (b) Underground production
 (c) Quarry production

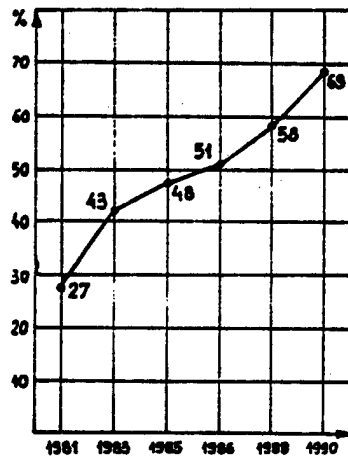

Figure 2. Cutting mechanization during the 1981-1985 and 1986-1990 five-year plans.

The mechanization of technical processes has required greater concern for personnel qualification and improved professional training, a determining factor for the efficient utilization of mechanized and automated facilities.

The 13th Party Congress has assigned extremely important tasks for increasing the extraction of power production coal, through the exploitation of new reserves and the opening of new mines and quarries, for which the Ploiesti MC has an extensive program to conduct geologic research and open new mines.

Beginning this year and continuing into the 1986-1990 five-year plan, new mines will be opened in Arges County at Capul Piscului, Jugur-Est, Slanic-Sud, and Topolog-Vilsan.

In Prahova County, mines will be opened at the new areas of V. Mislea-V. Cosiminei, Malaiesti-Cotofanesti, Mugureni-Tufeni, and Rotari-Calugareni. Also in Prahova County, we are planning geologic research aimed at reopening bituminous sand areas, and together with the Boldesti Drilling-Extraction Trust, we are developing the Monteoru oil mine; in the 1986-1990 five-year plan we will participate in the Bustenari oil mine project.

In Dimbovita County, we will research and open the mines Vulcana-Pandele, Resca-Glodeni, and Cindesti-Aninosani.

In Covasna County we are opening the Virghis-Est and Baraolt-Sud mines, and will place in operation the new facility at the Bodos mine.

In Brasov County, we will complete geologic research and will start opening the Vladeni-Dimbovita lignite deposit, and in Buzau County will reopen the Ojasca lignite deposit.

In order to increase the energy potential south of the Carpathians and in the Muntenia plain, between Milcov and Olt, we are researching together with the University of Bucharest new possible areas that bear power producing coal, which will form the basis of detailed geologic research.

The successes obtained by miners and all workers at the Ploiesti MC, are in response to the conditions which our party assures for miners, and to the care which Nicolae Ceausescu, secretary general of the party, demonstrates for all the country's miners and their families. We dedicate these successes to the 41st anniversary of the antifascist and anti-imperialist revolution for social and national liberation, and to the 56th anniversary of the battle of the Lupeni miners.

11,023

CSO: 2702/6

ROMANIA

INCREASED COPPER PRODUCTION AT DEVA ORE CENTRAL

Bucharest MINE, PETROL SI GAZE in Romanian Vol 36 Aug 85 pp 386-388

[Article by A. Lapusca, director general of the Deva Ore Central]

[Text] A priority objective in the documents of the 13th Congress of the RCP, is to increase the basis of raw materials, so as to supply as many of the needs of the national economy as possible.

The mining units of the Deva Ore Central (CM) are also contributing to this important task, especially by bringing into the economy deposits with low ore content, as indicated by the higher leadership of the party, and personally by the secretary general, Nicolae Ceausescu.

In this respect, through the joint efforts of mining units and geologic research units, the reserves disclosed in this category of ores have grown six-fold during the past 15 years, primarily in deposits at Moldova Noua, Caras-Severin County, Rosia Poieni, Alba County, and in the areas of Valea Morii-Brad and Coranda-Hondol, Hunedoara County.

Production activities have started at all four objectives, using technologies formulated by our specialists, as well as high capacity equipment designed and built for the first time in Romania through the joint efforts of specialists in the machine building industry.

One illustration of this development can be found in the value of fixed assets installed so far, which in 1985 was twice as high as in 1980.

These investments efforts are materialized in a strong ore production growth.

For instance, the amount of copper ore planned to be extracted and processed by the central's units in 1985 is 3.65 times higher than in 1980, while the production for 1990 is expected to be 8.4 times higher than in 1984. Similarly, the 1985 production of complex ores was twice that of 1980.

Practice has confirmed that the development of the raw materials basis through the opening of large facilities can be achieved only with the direct contribution of research and the encouragement of technical progress; only thus was it possible to build high capacity and high productivity equipment.

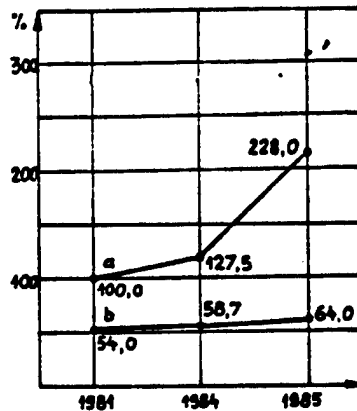

Figure 1. Total ore production growth at the Deva CM during the 1981-1985 five-year plan

- (a) Ore production
- (b) Copper ore production

In this respect we can mention excavators with 8 cubic meter buckets, dump trucks with 50 and 100 ton capacities, quarry augers, one- and two arm perforating machines mounted on rubber tires, installations for boring long holes for shafts, bucket and transfer station loaders, and so on.

At the ore preparation plants of large installations, we are finalizing procedures for automatic process control of technical operations.

In flotation technology we have introduced modern equipment (high capacity crushers for self-milling, flotation cells with mechanical agitation and subaeration, and so on), thus not only increasing extraction yields for basic metals (Cu, Pb, Zn), but also establishing a technology for obtaining molybdenum concentrates, a byproduct whose exploitation is of great economic importance.

The concern to increase the recovery of metals has also broadened to technical wastes from mines and preparation plants, where through the use of modern processes (magnetic separation, bacterial leaching, and so on) we foresee the recovery of additional amounts of metals.

Together with the actions undertaken to develop production, and for the comprehensive exploitation of ore reserves and the modernization of technologies, the attention of the central and of its units has been focused on improving living and working conditions.

One primordial task assigned by the Directives of the 13th Party Congress, is to constantly improve the qualification level of the personnel, consistent with the installation of very complex and high performance equipment.

In this respect, during the 1981-1985 five-year plan we have diversified the training in units and in specialized schools at the Deva CM.

In conjunction with our units we are thus operating high schools and professional schools for various forms of education for qualification in various trades. In 1985, these school groups included 6900 students.

Attention is also being given to improved working conditions, the prevention of environmental pollution, housing, food, and transportation.

Significant funds have been allocated for these actions, amounting to 33 million lei in 1985 alone.

Based on the achievements obtained so far, the workers' collective at the Deva CM and its enterprises will act decisively to conclude 1985 with new results, and to lay the best possible foundations for the fulfillment of their tasks in 1986, the first year of the next five-year plan.

11,023

CSO: 2702/6

ROMANIA

INCREASED NON-FERROUS ORE PRODUCTION AT BAIJA MARE CENTRAL

Bucharest MINE, PETROL SI GAZE in Romanian Vol 36 Aug 85 pp 388-391

[Article by N. Dieu, director general of the Baia Mare Ore Central]

[Text] As part of the party and state strategy for a strong and balanced development of the national economy, defined by the party program, the directives of party congresses, five-year plans, and branch development programs, the mining industry occupies a leading position, the role of mineral raw materials being essential in any modern, complex, diversified, and highly technologic economy. The priority role of minerals can be observed during the entire period of planned economic development, but especially after the Ninth Congress of the RCP, which gave a new impetus and orientations to the entire economic development, being based on thorough scientific analysis.

The orientations of the Ninth Congress, amplified, complemented, and implemented by new party documents during the 20 years of this bright era of Romania's multilateral development, have had a favorable and constant influence on the activities of the Baia Mare Ore Central (CM). This favorable influence has been felt both through established tasks, and especially through the broad support received consistently to accomplish all these tasks, and primarily the priority tasks, in an acceptable technical and economic manner.

Of particular importance among the tasks that have been and are assigned to the mining units of the central, is the the one to constantly increase ore extraction so as to maintain the production of non-ferrous and noble metals at a suitable level, compensating for the natural decline in the quality of the reserves in some zones being exploited. The response of the Baia Mare Central in fulfilling this task is illustrated by the fact that its share in the production of ore concentrates of non-ferrous metals is still quite high: more than 80 percent for lead and zinc, and more than 30 percent for copper.

The highest production growths are found at units with high reserves, among which Baia Borsa IM (Mining Enterprise), Suisor EM (Mining Exploitation), and Rodna EM.

Production growth rate was sustained by measures taken at the branch, local, central, and unit levels.

As part of these measures, the decisive role is played by the outstanding efforts of the national economy to assure the development of the technical-material basis of the mine extraction industry in our country, efforts which have fully benefited the units of the Baia Mare CM and Maramures County, where more than 80 percent of the central's non-ferrous metal production is concentrated.

The main objective of these efforts was continued growth in the volume of ore reserves, consistent with the development tasks for greater ore production.

The data in figure 2 is an eloquent illustration of the effect of these efforts during the past 20 years in Maramures County.

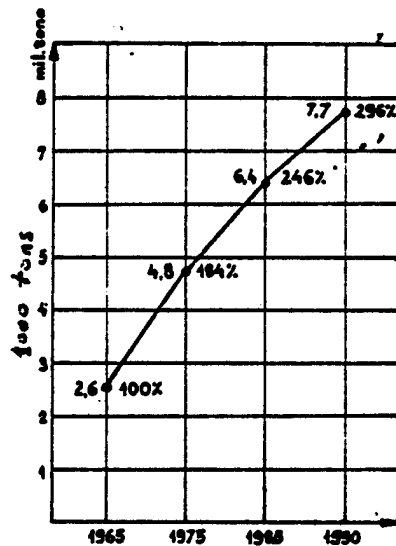

Figure 1. Production of non-ferrous ores by units of the Baia Mare CM

For the central as a whole, the geologic research effort can be summarized as follows:

During the current five-year plan the total value of geologic projects amounts to more than 970 million lei, growing from 169 million in 1981, to 235 million in 1985;

More than 1300 million lei of geologic work is projected for the 1986-1990 five-year plan, with about 250 million in 1986 alone;

During the current five-year plan, geologic work adds up to more than 151,000 meters of galleries, 15,000 meters of shafts, and 45,000 meters of drilling.

As a result of these geologic research efforts on the part of the central's units, as well as that of prospecting and exploration enterprises of the Ministry of Geology, which are conducting their activities in Romania's four northern counties (Satu Mare, Maramures, Bistrita-Nasaud, and Suceava), the mining units are adequately assured of geologic reserves.

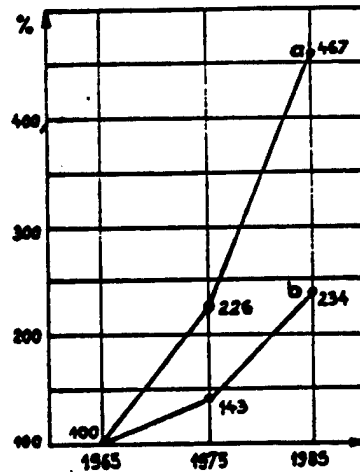

Figure 2. Geologic activity indicators
 (a) Value of geological projects
 (b) Volume of B + C1 known reserves

The accomplishment of this goal is based among other things, on expanding searches into the depths of some mines, particularly at Cavnic, where the available data indicates the existence of large reserves of non-ferrous ores at the second range of depth (between 1000 and 2000 meters from the surface).

During the next five-year plan, based on existing programs, new deposits of multi-metal ores will be brought into circulation, among which the Dealul Crucii mine in the Sasar area, the Galbena mine in the Nistru area, the large deposit between the Baia Sprie and Suisor mines, Cisma in the Baiut area, Novat in Baia Borsa, Socea in Tarna, the Faget VI-th zone at Rodna, and so on.

The reserve growth activity was complemented with the opening of new mining zones, the modernization of existing mines and preparation plants, and the development of their capacities.

Significant investment funds were thus allocated together with those committed for geological research.

Based on these investments, during 1965-1985 the endowment of the central's mining units in Maramures County was increased by 27 expansions or new extraction facilities, seven preparation plant expansions, a mining equipment and repairs plant, as well as other industrial and sociocultural objectives.

Investment efforts during the next five-year plan will remain high, amounting to 6 billion lei.

Together with the development of production capabilities, special attention was devoted to the introduction of technologic progress.

More than 82 percent of the production from stopes is currently obtained with high productivity methods, with loading in galleries being more than 85 percent mechanized; in 1985, these two indicators were 48.6 percent and 52.2 percent respectively. Manual loading and transportation in stopes was restricted to only a few percent; in the majority of mines these operations are performed with silo loading machines, scrapers, or by gravity.

Methods which allow the use of high efficiency equipment, and particularly substage methods, are finding increasing expansion among high productivity methods.

Through the efforts of units, of the research institute of the central's mining equipment plant, and through collaborations with specialized units at MICM (Ministry of the Machine Building Industry), important problems were solved for underground and surface mechanization.

Several types of perforation carts (for galleries, precutting, excavation with transfer stations, substage stopes) were built, and loading machines with buckets as large as three cubic meters, as well as transfer station loading and transportation machines up to three cubic meters, were introduced in units.

We have generalized the loading of material from shafts with scraper belt installations, and tested with good results the digging of shafts using long parallel holes; and we are currently testing a CI-2 combine to dig galleries, as well as loading machines with lateral arms.

The central's plant has perfected the construction of a universal tracked drilling cart (CPU-1s) and of a cart for perforating pilot holes in a fan-shaped pattern. The plant industrially produces two types of heavy borers (weighing 95 and 155 kg) to drill intermediate holes, including the ancillary installations for their utilization.

Preparation plants have increased their capacities by expanding crushers for self-milling, and the use of improved and larger flotation cells (we are presently testing prototypes of the 2 x 20 m cell built by our own tooling plant). And we have undertaken the automation of some process phases and the use of industrial television.

As a result of these efforts most of the units and the central have repeatedly surpassed the plan during 1965-1985, allowing some of them to occupy leading positions in the socialist competition within the branch (Cavnic EM, Ilba EM, Vatra Dornei EM, Baiut EM, Baia Mare EM, and so on). The Cavnic EM, which has consistently been among well performing units, has several times ranked first place in the competition, and even the title of Hero of Socialist Labor, being the first unit in Maramures County and in the country's mining industry to see its efforts crowned with this high distinction, symbol of competence, selflessness, enthusiasm, and working efficiency.

The workers' collectives at the Baia Mare CM are determined to make sustained efforts in the future and devote all their skills and working strength to fulfill the 1985 plan tasks, as well as the important tasks assigned by the Directives of the 13th Congress of the RCP for the 1986-1990 five-year plan.

11,023

CSO: 2702/6

ROMANIA

USE OF NEW POLYURETHANE IN LEATHER SUBSTITUTE

Bucharest INDUSTRIA USOARA in Romanian No 5 May 85 pp 202-211

[Article by Carmen Anghel and Tudorel Lungu: "Use of Romanian Polyurethanes of the Nadolsin Type in Leather Substitute Manufacture by Indirect Layering"]

[Text] There are two basic trends to be observed worldwide in the area of poromeric and non-poromeric leather substitutes. There is, first of all, the spectacular Japanese development of poromeric synthetic leather of the Alcantara type, which possesses characteristics approaching those of natural leather, and then there are the sustained efforts to improve the current generation of synthetic leathers by modifying polymers, textile backings, finishes, technologies, and so forth.

The question of polyurethanes for finishing or indirect layering uses has been, and continues to be, an object of ongoing attention in this context. Many types of polyurethanes have been developed for this purpose, for both the surface and the adhesive layers, each of which has a composition and properties of its own.

There are three product generations in the area of polyurethane-based leather substitutes, two-component systems, single component systems, and dispersed systems. These systems and elements of each system can be combined to obtain a variety of articles. For example, mixing a single-component with a two-component polyurethane containing chemical cross-linking agents yields films of high hardness.

In the case of single-component polyurethanes, physical combinations not involving chemical cross-linking can yield an array of properties tailored to a particular area of application.

This fact has been utilized to develop an entire industry of non-poromeric polyurethane-based leather substitutes, and this industry has been stimulated by the constant updating and diversification of raw materials.

Until 1979, all production of polyurethane-based leather substitutes depended on imported raw materials. In that year, research conducted by the Petru Poni Institute of Macromolecular Chemistry in Iasi (which is under the Ministry of the Chemical Industry), to which a contribution was made by ICPI (Industrial Research and Development Institute), culminated in startup of the production of various types of polyurethane under the brand name

Nadolsin, some of them applied in the area of leather substitutes obtained by indirect layering.

The Romanian high-elasticity polyurethane Nadolsin PR 102 was tested by ICPI and found to be suitable for use in obtaining non-poromeric leather substitutes used in the manufacture of footwear. It was given official approval by INMP in Bucharest.

The polyurethanes PR 102 and PR 103 have also used as adhesives. Further research has been undertaken to develop assortments for use in the wear layer.

The difficulty has been that the concept of developing an assortment that can be applied by the transfer process (indirect layering) was not adopted in the synthesis of these polyurethanes. The concept followed has rather been that of continuous adaptation of the substances produced by immersion and coagulation.

For example, the polymer Nadolsin PR 101 S was introduced as a wear layer leather substitute for leather goods. The limited field of application is due to the low resistance values obtained in repeated Bally bending tests at low temperatures (-15 °C). This situation was repeated in the case of the new type, Nadolsin PR 100 S.

The Polyurethane Nadolsin PR 200 S

Nadolsin PR 200 S is a urethane elastomer with a softening range lower than that of the earlier PR 100 series. It has been synthesized to facilitate the operation of pebbling in operations requiring such treatment, out of energy considerations.

The new polymer, which is synthesized in solution on the basis of fatty polyethylene glycol, fatty polyethylenediethylene glycol, trimethylolpropane, and two different varieties of diisocyanate, is a mixture of two phases in thermodynamic equilibrium, one of which (the continuous phase) is the polymer lining and the second (the discontinuous phase) a polymer of high crystallinity. Thermodynamic equilibrium is achieved as a result of the similar structure of the two phases, which permits suitable processing even after prolonged storage.

The structure of the new type of polyurethane has been confirmed by IR, UV, and RMN spectroscopy. The polyurethane Nadolsin PR 200 S has been developed and manufactured to obtain poromeric synthetic leather by the layering and coagulation process. Research has been conducted to determine the possibility of extending the range of application of the new type of polyurethane to non-poromeric leather substitutes made by the process of layering on release paper.

Experimental Projects

The polyurethane solutions which have been the subject of research were made available by the Sintofarm enterprise in Bucharest.

These polyurethane solutions have been characterized from the viewpoint of dry matter content, viscosity at various temperatures, layering behavior, compatibility with and assumption of the release paper design, bulk coloring potential, and plasticization and additive addition potential.

Films and layers obtained from polyurethanes with Werner-Mathis equipment have been characterized from the viewpoint of tensile strength and elongation, modulus of elasticity, resistance to repeated bending at normal and low temperatures, static permeability to water and water vapor, resistance to solvents and friction wear, and also adhesion of the film to a lining and the effect of an adhesive on the properties of the wear layer.

A comparative study has been made of the chief physicochemical properties and physicomechanical characteristics of the new type of polyurethane, both with polyurethanes of the PR 100 series and with the polyurethanes Larithane MS 130, Ucecoat TM, and Ucecoat CS1.

Results and Discussion

The degree of polymerization and the macromolecular distribution, as variables, may be inferred on the basis of the dry matter content (36.90 ± 0.88 percent) and the viscosity of polyurethane solutions at different temperatures, which varies from batch to batch (at a temperature of 20°C , for example, the viscosity ranges from 83.4 to 119.8×10^3 cP, by more than $\pm 10 \times 10^3$ cP, as against the arithmetic mean of $95.0 \pm 10 \times 10^3$ cP) (Table 1).

The tensile strength, repeated bending strength, solution viscosity, and so forth, are determined in direct proportion to the degree of polymerization and macromolecular distribution of the polymer. The results obtained for batches of the polyurethane Nadolsin PR 200 S, relative to the reference products Ucecoat TM and Larithane MS 130 (Table 2), indicate the need for producing batches which are constant and reproducible from the viewpoint of basic physicochemical properties, since it is known to be important to conduct the polymerization process so as to obtain a polymer with a certain average chain length, that is, with the same average degree of polymerization.

Solutions of Nadolsin PR 200 S polyurethane spread suitably. They exhibit no delamination and no fish-eye or crocodile effects when subjected to working by the technology applied for production of non-poromeric leather substitutes by transfer to release paper. They also readily absorb pigment pastes so that uniformly colored polyurethane solutions may be obtained.

When a film of Nadolsin PR 200 S is exposed to light (in the Xenotest), the film exhibits no resistance to light; the behavior of the other polyurethanes studied is similar in this respect. The result is positive when ultraviolet absorbers are added.

Bally repeated bending strength testing at normal and low temperatures (-15°C) reveals that the test pieces examined behave differently as a function of the direction of cutting (parallel or perpendicular), and also that the temperature even affects the polyurethane as such (Table 3). When examined

under light, the polyurethane film reveals high porosity marked by large open pores which rapidly permit cracking and splitting of the film in the bending process.

Table 1

(1) Poliuretani/ parja	(2) Stăru uscata, %	(3) Viscositatea (Drage) $\times 10^4$ cP				
		10°C	15°C	20°C	25°C	30°C
PR 200 S/3	37,50	158,7	122,4	104,3	94,8	79,4
PR 200 S/6	36,03	143,3	131,2	115,9	104,8	95,6
PR 200 S/7	36,88	149,8	113,4	92,7	88,5	83,1
PR 200 S/8	37,03	139,8	119,5	98,8	91,7	74,5
PR 200 S/9	36,06	154,4	122,0	119,8	104,5	100,2
PR 200 S/10	36,50	132,3	122,0	97,2	94,2	85,6
PR 200 S/11	36,80	119,1	114,8	95,6	87,7	85,0
PR 200 S/14	37,78	149,1	107,7	86,7	77,0	—
PR 200 S/16	36,60	98,6	89,5	83,4	78,7	75,1
PR 200 S/17	38,30	92,5	85,2	79,9	75,6	71,6
PR 200 S/18	37,10	96,9	90,1	84,9	79,0	74,5
PR 200 S/20	37,85	—	—	85,0	—	—
PR 200 S/3*	39,70	189,5	160,2	111,3	96,6	83,2
PR 101 S	40,00	86,3	68,9	56,8	41,9	29,9
Ucecoat TM	29,9	69,3	54,1	49,9	40,2	37,2
Larithane MS 130	35,5	160,8	138,9	108,4	86,9	71,9
PR 103	42,2	125,8	98,4	81,5	72,2	60,3
Ucecoat CS 1	33,1	68,4	37,2	22,3	16,4	10,4

(4) plastifiat cu 3,02% C₆ și 1,62% DOF

Key:

1. Polyurethane per batch
2. Dry matter, %
3. Viscosity (Drage)
4. Plasticized with 3.05% C₆ and 1.62% diisooctylphthalate

The water vapor permeability of the layered film on a textile backing is 395 milligrams in 24 hours, as against the minimum of 250 milligrams per 24 hours specified in the production standards. This high figure is explained by the large number of open pores in the film.

A wear layer of Nadolsin PR 200 S exhibits excellent resistance to benzine and toluene. This characteristic is of importance in the manufacture of footwear. The resistance to dry friction, damp, and heat is adequate (Table 4).

Since the structure of non-poromeric leather substitutes also includes an adhesive component ensuring adhesion of the wear layer to the textile backing, the influence of adhesive on the properties of the wear layer was determined. The values obtained for the physicommechanical characteristics indicate decrease in the tensile strength and the modulus of elasticity at 100-percent elongation. This decrease is much more significant in the case of imported polyurethanes (TM and MS 130 relative to Nadolsin PR 200 S; see Table 5). A number of plasticization studies were conducted to determine

the workability of Nadolsin PR 200 S polyurethanes. Plasticization was found to have a favorable effect on the tensile strength and elongation at rupture. At the same time, tests were run to determine the influence of the solvents used to dilute polyurethane solutions to achieve uneven application.

Table 2

(1) Poliuretan/ șarjă	(2) Rezistența la rupere, daN/mm ²		(3) Alungirea la rupere, %		(4) Modulul de elasticitate la 100% alun- gire, daN/mm ²	
		⊥		⊥		⊥
PR 200 S/3	3,95	3,65	442	436	0,62	0,60
PR 200 S/6	4,12	3,61	513	473	0,62	0,57
PR 200 S/7	4,46	4,30	470	436	0,96	0,91
PR 200 S/8	5,22	4,80	431	436	1,04	0,97
PR 200 S/9	4,58	4,52	490	437	0,91	1,02
PR 200 S/10	4,68	4,43	426	455	0,86	0,84
PR 200 S/11	5,81	5,04	523	501	0,91	1,14
PR 200 S/14	2,37	1,93	400	384	0,50	0,45
PR 200 S/16	5,36	3,74	456	410	0,91	0,37
PR 200 S/17	4,94	3,75	435	408	0,65	0,78
PR 200 S/18	4,40	3,52	514	429	0,58	0,59
PR 200 S/20	4,26	4,52	473	490	0,67	0,59
PR 200 S/3*	4,62	4,39	499	520	0,52	0,43
PR 101 S	1,67	1,72	532	548	0,66	0,66
Ucecoat TM	5,32	4,98	535	516	0,73	0,83
Larithane MS 130	5,57	4,84	548	544	0,70	0,70
PR 103	2,84	2,39	882	824	0,28	0,28
Ucecoat CS 1	0,77	0,77	848	848	0,17	0,17

(5) șarjă 3, plastifianți cu 3,05% C₆ și 1,62% DMF

Key:

1. Polyurethane per batch
2. Tensile strength, daN/mm²
3. Elongation at rupture, %
4. Modulus of elasticity at 100% elongation, daN/mm²

5. Batch 3, plasticized with 3.05% C₆ and 1.62% dimethylformamide

Table 3

	(1) Caracteristici fizico-mecanice	(2)	(3)	(4)
		PR 200 S ca atare	PR 200 S cu plasti- fianți colorați	MS 130 colorat
(5)	Rezistența la flexiuni repetate, număr flexiuni $\times 10^3$			
(6)	— la temperatură normală			
(7)	paralel	200,0	60,0	48,0
(8)	perpendicular	60,0	18,0	48,0
(9)	— la -15°C			
	paralel	36,0	12,0	48,0
	perpendicular	6,0	6,0	18,0

Key:

- | | |
|---------------------------------------|--|
| 1. Physicomechanical characteristics | 5. Repeated bending stress strength, number of bends $\times 10^3$ |
| 2. PR 200 S alone | 6. At normal temperature |
| 3. PR 200 S with colored plasticizers | 7. Parallel |
| 4. Colored MS 130 | 8. Perpendicular |
| | 9. at -15°C |

Table 4

	(1) Caracteristici fizico-mecanice	(2) NOTE		
		(3) Limite	(4) valori	N.T.I.
(5)	Rezistența la solvenți			
(6)	— benzină	1-5	5	4...4-5
(7)	— toluen	1-10	10	2
(8)	Rezistența la frecare			
(9)	— uscată	1-5	5/4-5	4-5/4-5
(10)	— umeză	1-5	5/4-5	4-5/4-5
(11)	— caldă	1-5	5	2

Key:

- | | |
|--------------------------------------|------------------------|
| 1. Physicomechanical characteristics | 6. Benzine |
| 2. Ratings | 7. Toluene |
| 3. Range | 8. Friction resistance |
| 4. Values | 9. Dry |
| 5. Resistance to solvents | 10. Wet |
| | 11. Hot |

Table 5

(1) Caracteristici fizico-mecanice	(2) U.M.	A	B	C	D	E	G	F	H	I
(3) Stratul de uzură		PR 200 S	PR 200 S	PR 200 S	TM	TM	TM	MS 130	MS 130	MS 130
(4) Stratul de adeziv		—	PR 103	CS 1	—	PR 103	CS 1	—	PR 103	CS 1
(5) Rezistența la rupere										
(6) — paralel	daN/mm ²	4,62	2,96	3,26	5,22	2,13	1,89	5,07	2,68	2,11
(7) — perpendicular	daN/mm ²	4,36	2,58	2,14	4,98	2,61	1,83	4,89	2,95	2,05
(8) Alungirea la rupere										
— paralel	%	499	560	386	535	474	426	548	496	446
— perpendicular	%	520	577	386	516	501	430	544	496	432
(9) Modulul de elasticitate 100% alungire										
— paralel	daN/mm ²	0,51	0,48	0,58	0,73	0,39	0,42	0,70	0,47	0,40
— perpendicular	daN/mm ²	0,43	0,42	0,54	0,83	0,38	0,39	0,70	0,52	0,45

Key:

- | | |
|--------------------------------------|--|
| 1. Physicomechanical characteristics | 5. Tensile strength |
| 2. Unit of measurement | 6. Parallel |
| 3. Wear layer | 7. Perpendicular |
| 4. Adhesive layer | 8. Elongation at rupture |
| | 9. Modulus of elasticity at 100-percent elongation |

As is to be seen from Table 6, the polyurethane Nadolsin PR 200 S must be plasticized so that films suited to the field of application may be obtained following the dilution required for processing.

Findings

On the basis of the results of research conducted in accordance with an original methodology to determine the possibility of using Romanian polyurethanes of the Nadolsin series to produce leather substitutes by the indirect layering process, the following findings may be advanced.

Because of their suitable adhesive properties, the polyurethanes Nadolsin PR 102 and PR 103 are indicated for production of leather substitutes to be used in the manufacture of footwear and clothing.

The polyurethane Nadolsin PR 101 S may be used as a wear layer for leather substitutes to be used in manufacture of leather goods.

The polyurethane Nadolsin PR 200 S may be used as a wear layer provided that care is taken to keep the batches constant and reproducible during synthesis from the viewpoint of physicochemical properties, and especially as regards macromolecular distribution of the polymer.

Table 6

(1) Caracteristici fizico-mecanice	(2) U.M.	A	B	C
(3) PR 200 S		200	191	191
(3) Plastifianti C 6		—	6	6
(4) Diizooctilftalat		—	3	3
(5) Dimetilformamidă		—	—	43
(6) Toluen		—	—	43
(7) Viscositatea (Dräge)	$\times 10^3$ cP			
10°C		158,8	189,5	20,5
15°C		122,4	160,2	12,9
20°C		104,3	111,4	9,0
25°C		94,8	96,6	6,5
30°C		79,5	83,2	3,2
(8) Rezistența la rupere				
(9) — paralel	daN/mm ²	3,93	4,62	3,2
(10) — perpendicular	daN/mm ²	3,65	4,39	3,2
(11) Alungirea la rupere				
— paralel	%	442	499	448
— perpendicular	%	426	522	431
(12) Modulul de elasticitate la 100% alungire				
— paralel	daN/mm ²	0,62	0,51	0,50
— perpendicular	daN/mm ²	0,60	0,43	0,55

Key:

- | | |
|--------------------------------------|--|
| 1. Physicomechanical characteristics | 7. Viscosity (Drage) |
| 2. Unit of measurement | 8. Tensile strength |
| 3. C 6 plasticizers | 9. Parallel |
| 4. Diisooctylphthalate | 10. Perpendicular |
| 5. Dimethylformamide | 11. Elongation at rupture |
| 6. Toluene | 12. Modulus of elasticity at 100% elongation |

At the same time, the low-temperature strength must be improved so that the field of application will not be limited exclusively to leather substitutes for leather goods.

Since the production of leather substitutes based on polyurethanes obtained by indirect layering is important, both from the quantitative viewpoint and from that of variety of applications, it is believed necessary to study and develop a number of specific polyurethanes for these technological processes. Such research should be undertaken with a view toward modifying the polyurethanes developed for the immersion-coagulation technology in order to ensure limited satisfaction of the needs of this sector.