

NTIAC-SR-98-01

NEUTRON RADIOGRAPHY

A State-of-the-Art Report

By

Harold Berger
Industrial Quality, Inc.

and

Frank Iddings
Professor Emeritus
(Louisiana State University, 1985)

Prepared for

NTIAC

Nondestructive Testing Information Analysis Center
A DoD Information Analysis Center Sponsored by the
Defense Technical Information Center (DTIC)

August 1998

Approved for Public Release; Distribution Unlimited

19981026 007

This document was prepared by the Nondestructive Testing Information Analysis Center (NTIAC), TRI/Austin, Inc., 415 Crystal Creek Drive, Austin, TX 78746-4725. NTIAC is a full service information analysis center sponsored by the U.S. Department of Defense, serving the information needs of the Department of Defense, other U.S. Government agencies, and the private sector in the field of nondestructive testing.

NTIAC is operated under Contract SPO700-97-D-4003 with the Defense Technical Information Center (DTIC). Technical aspects of NTIAC operations are monitored by the Office of the Director of Defense Research and Engineering (Platform and Materials Technology).

Additional copies of this document may be obtained from:

NTIAC
ATTN: Shelly Clark
415 Crystal Creek Drive
Austin, TX 78746-4725
Phone: (512) 263-2106 or (800) NTIAC 39
Fax: (512) 263-3530
E-mail: clark@ntiac.com

This document was prepared under the sponsorship of the U.S. Department of Defense. Neither the United States Government nor any person acting on behalf of the United States Government assumes any liability resulting from the use or publication of the information contained in this document or warrants that such use or publication of the information contained in this document will be free from privately owned rights.

Approved for public release; distribution unlimited
All rights reserved. This document, or parts thereof may not be reproduced in any form without written permission of the Nondestructive Testing Information Analysis Center.

Copyright© 1998, Nondestructive Testing Information Analysis Center.

PREFACE

This State-of-the-Art Report on Neutron Radiography was prepared for NTIAC by two recognized experts in the technology, Harold Berger, President of Industrial Quality, Inc., Gaithersburg, MD, and Frank Iddings, Professor Emeritus, Louisiana State University, 1985.

The text of the report is organized into sections covering Introduction, Theory, Neutron Sources, Moderation and Collimation, Neutron Imaging Techniques, Standards/Recommended Practices, Applications, and Conclusions. References appear in Section 8.0.

TABLE OF CONTENTS

	Page	
Preface	iii	
Table of Contents	v	
List of Figures	ix	
List of Tables	xiii	
1.0	Introduction	1
1.1	Objective	1
1.2	Scope	1
1.3	Definitions	2
1.4	Advantages	4
1.5	Limitations	5
1.6	Historical Development	6
2.0	Theory	8
2.1	Neutron Production Principles	8
2.2	Neutron Energies	8
2.3	Neutron Interactions, Scattering, Nuclear Absorption, Fission	9
2.4	Radioisotope Sources, Accelerator Sources, Nuclear Reactors	12
2.5	Neutron Detection, Converter Screens	15
2.6	Neutron Shielding	19

TABLE OF CONTENTS (CONT'D)

		Page
3.0	Neutron Sources, Moderation and Collimation	20
3.1	Moderation	20
3.2	Collimation	21
3.3	Nuclear Reactors	23
3.4	Accelerator Sources	25
3.5	Radioisotope Neutron Sources	28
3.6	Sub-Critical Assemblies	29
4.0	Neutron Imaging Techniques	30
4.1	Indirect or Transfer Imaging Techniques	30
4.2	Direct Neutron Imaging	32
4.3	Radioscopy (Real Time Imaging)	34
4.4	Neutron Computed Tomography	36
4.5	Other Neutron Imaging Techniques	36
4.6	Contrast Agents	39
5.0	Standards/Recommended Practices	40
5.1	System Performance	40
5.2	Personnel Qualification	45
5.3	Regulatory Control	46
6.0	Applications	47
6.1	General Applications	47
6.2	Aerospace Applications	49
6.3	Explosive Devices	52

TABLE OF CONTENTS (CONT'D)

		Page
6.4	Electronic Devices	56
6.5	Nuclear Applications	56
6.6	Motion/Dynamic Applications	57
6.7	Miscellaneous Applications	59
7.0	Conclusions	61
8.0	References	63
	Glossary	77

LIST OF FIGURES

		Page
Figure 1.1	Figure 1.1. A comparison of mass attenuation coefficients for the elements for both medium energy x-rays (about 125 kV, solid line) and thermal neutrons (dots). This curve reproduced from Ref. 12, is based on an earlier version, by Thewlis (33).	4
Figure 2.1	Diagrams illustrating the direct film exposure method (upper view) and the indirect, or transfer method (lower view), in which the film is not directly exposed to the neutron imaging beam (Ref. 12).	15
Figure 2.2	Diagram of typical radiosopic imaging system. The turning mirror removes the camera from the direct radiation beam. The image intensifier is optional; optics are not shown. The CCD camera is often used in neutron radiosopic systems.	18
Figure 3.1	Moderator-collimator arrangement surrounding a fast neutron source. The thermal neutron beam can be characterized by the L/D ratio (55).	22
Figure 3.2	Diagram of a neutron radiographic beam at the University of Virginia reactor, showing the reactor core and reflector (lower left) and beam filters, about 1/3 the length up the beam tube (57).	24
Figure 3.3	Photograph of a transportable (d,T) neutron source shown set up to radiosopic inspection of a helicopter blade. The round object below the blade houses the accelerator target, moderator and collimator (44).	25
Figure 3.4	Diagram of a Van de Graaff accelerator, showing how the charges are moved along the belt to build up a high voltage charge (19).	26
Figure 3.5	Drawing of a design for a transportable RFQ accelerator neutron source. Note the accelerator length on the bottom scale, 9 m (63).	27
Figure 3.6	Artist drawing of a transportable cyclotron neutron radiography source (65).	28

LIST OF FIGURES (CONT'D)

Figure 4.1	Direct thermal neutron radiograph taken with a gadolinium screen showing a cracked double cantilever beam aluminum sample. Hydrogen deposits along the vertical crack above the location where the screws meet is evident. The cadmium test bar at the left shows images of many small holes, including the sequence at the top, 0.25mm holes spaced 0.25mm apart (71).	33
Figure 4.2	A transfer thermal neutron radiograph of irradiated nuclear fuel shows cladding rupture and fuel deposits in the bottom. Image taken with an indium transfer screen (72).	34
Figure 4.3	A track-etch neutron radiograph of nuclear fuel, showing extensive cracking (69).	34
Figure 4.4	A dynamic thermal neutron sequence showing the pouring of Wood's metal into an aluminum mold. The time for the entire sequence was 0.66 seconds (34).	35
Figure 4.5	Transfer neutron radiographs of irradiated, enriched nuclear fuel. The view at the left was taken with thermal neutrons for dimensional measurements. The view at the right, taken with a cadmium-filtered indium screen technique, shows improved penetration of the fuel to observe internal cracking and deposits (70).	37
Figure 4.6	Diagram showing the sequence for a storage phosphor radiation imaging system.	38
Figure 4.7	Thermal neutron radiograph of investment turbine blades showing evidence of residual ceramic core after leaching. Gadolinia is added to the ceramic core material or a gadolinia wash is used after leaching to increase detection sensitivity (see references 103 and 104).	39
Figure 5.1	Beam purity indicator (BPI) test piece as described in ASTM E 545, 1998. (From ASTM E 545, reference 106.) Reprinted with permission.	41
Figure 5.2	Sensitivity Gage as described in ASTM E 545, 1991. (From ASTM E 545, reference 106.) Reprinted with permission.	42
Figure 5.3	Geometry of a neutron radiographic system.	43

LIST OF FIGURES (CONT'D)

Figure 5.4	<p>Test piece used for measurement of L/D. This support piece is mounted at a 45-degree angle over the detector to space absorbing rods (cadmium, nylon) at various distances from the detector.</p> <p>(From ASTM E803, reference 56.) Reprinted with permission.</p>	44
Figure 6.1	<p>Thermal neutron radiograph of a metal assembly showing "O" rings. The arrows indicate rings that have twisted out of the groove so that they no longer seal (122). Courtesy Aerotest Operations Inc.</p>	47
Figure 6.2	<p>Neutron radiograph of an aluminum honeycomb structure. The white linear indication shows adhesive coupling two core sections together. The whitish spots show early indications of corrosion (119).</p>	49
Figure 6.3	<p>Neutron radiosopic image of an aluminum aircraft structure showing images of corrosion (dark, irregular areas, particularly in the upper left). The rectangular image at lower left shows an acrylic, stepped wedge test piece containing holes (120).</p>	50
Figure 6.4	<p>Photograph of a robotic arm at the maneuverable inspection bay at McClellan Air Force base. The large round structure at lower left is the moderator-collimator housing for the Cf-252 neutron source. The inset is a diagram of the on-aircraft inspection facility for F-111 aircraft (29, 119).</p>	51
Figure 6.5	<p>Neutron (left) and X-radiographs (right) of an explosive bolt about 2 inches high. The x-ray image shows the metallic parts. The neutron image shows plastic, epoxy, paper (slanted white line near the top) and the explosive charge (salt and pepper image near the top, inside the stainless steel cap) (34).</p>	53
Figure 6.6	<p>Neutron (left) and x-radiographs (right) of three explosive bolts (A, B and C) showing differences in the images (122). Courtesy: Aerotest Operations, Inc.</p>	54
Figure 6.7	<p>Neutron radiographs of 45-caliber ammunition (upper views) compared to x-ray images at 150 kV (lower left) and 90 kV (lower right) (122). Courtesy: Aerotest Operations, Inc.</p>	54

LIST OF FIGURES (CONT'D)

- Figure 6.8 Neutron radiographs of small explosive tips used to initiate mechanical actions in remote locations. The tip at left is satisfactory although the upper pellet shows slightly lower density. The tip at right shows separation between the two pellets. The middle sample (tip at the bottom) shows a missing pellet. 55
- Figure 6.9 Neutron radiograph of an ordnance device, 2¾ inch diameter, showing detail near the thin top and in the cracked region at lower center. Courtesy: J. Moravec, U.S. Army Proving Ground, Yuma, Arizona. 55
- Figure 6.10 Neutron radiographs of relays. Any foreign materials could result in electrical connection problems (119). Courtesy Aerotest Operations, Inc. 56
- Figure 6.11 Neutron radiosopic images of a GEM turboshaft engine. Left is a static view. Right is a dynamic view, engine running. The images show that the oil scavenge pipe (lower center) has little oil in it during operation, an indication of poor oil circulation (78). 58
- Figure 6.12 Neutron xeroradiograph of a lead vessel, dating back to about 1,000 B.C. The image shows the vessel is empty and also outlines the dark shadows of corrosion along the walls and at the cover, which was corroded closed (146). 60

LIST OF TABLES

		Page
Table 1.1	Neutrons Classified According to Energy	3
Table 2.1	Typical Radioisotope Sources	13
Table 2.2	Examples and Characteristics of Neutron Converter Screen Materials	16
Table 3.1	Properties of Several Moderators	21
Table 5.1	General Training Topics for Neutron Radiographic Training	45
Table 6.1	Half Value Layer (HVL) for Thermal Neutrons	48

1.0 INTRODUCTION

1.1 Objective

Neutron radiography is becoming a well established nondestructive testing (NDT) method. The American Society for Nondestructive Testing (ASNT) has recognized the method through its recommended practice SNT-TC1A which outlines training, knowledge, and experience necessary to obtain levels of competency in the method (1, 2). Certification of nondestructive testing personnel is also covered in a military standard (3). Technical publications in the field of NDT and nuclear technology carry articles on neutron radiography and technical meetings include papers or even entire sessions on neutron radiography. There is an on-going series of international conferences on neutron radiography (4-11). Many books are available to provide introductory and advanced material on neutron radiographic techniques and applications (12-20). Neutron radiography as a service for hire is available, similar to that offered for other NDT services (21). The method is being adopted to solve NDT problems in specialty areas.

The objective of this report is to provide a brief survey of the current state of the art in the use of neutron radiography. The survey will include information on the technique including principles of the method, sources of neutrons, detection methodology, standards and image quality indicators, and representative applications. An extensive reference list provides additional information for those who wish to investigate further and a Glossary is included which provides definitions for terms used in Neutron Radiography.

1.2 Scope

This report is based on a review of pertinent open technical literature as well as a review of recent progress in the field. The literature search was accomplished by the Nondestructive Testing Information Analysis Center through its computerized documentation data bases.

The scope of this report includes introductory material with advantages and limitations of the method being presented along with a brief historical background. The theoretical section contains topics on neutron production, neutron energies, neutron interactions, neutron detection, geometric considerations, and neutron shielding. Neutron sources as well as moderators and collimators are discussed. Neutron imaging techniques, standards, and recommended practices are presented. Applications of neutron radiography to several important industrial and military areas are included.

It is assumed that the reader is already familiar with conventional X-ray and/or gamma radiography. Many publications are available that can provide that background information if it is needed (22-25).

1.3 Definitions

Neutron radiography is a specialized type of radiography. The definition of the term given in American Society for Testing and Materials (ASTM) (26) is as follows: "neutron radiography - the process of producing a radiograph using neutrons as the penetrating radiation." The neutron is defined as, "a neutral elementary particle having an atomic mass close to 1. In the free state outside of the nucleus, the neutron is unstable having a half-life of approximately 10 minutes." Additional definitions related to neutron radiography are given in ASTM document E 1316 (26) and in MIL-STD-1948 (27). The radiation terminology now accepted is to use the term radiology to include any radiation technique that involves ionizing radiation, e.g. x-rays, gamma rays, neutrons, etc. Neutron radiography specifically refers to the film technique. Neutron radioscopy refers to the electronic production of a neutron image that follows very closely the changes with time of the object being imaged. Radioscopy is the term for what has been called real-time radiography. Other neutron radiological techniques include neutron gauging (typically using tightly collimated beams) and neutron activation analysis (analysis of radiation emitted by materials made artificially radioactive by absorption of a neutron by the nucleus of the atom). In this report, the more familiar term neutron radiography will continue to be used except when reference is made specifically to neutron radioscopy (or real-time imaging).

Most neutron inspection has been done with thermal neutrons, neutrons in the energy range from 0.005 to 0.5 eV. These thermal neutrons show large differences in attenuation compared to those for x-rays, as discussed in Section 1.4. It is these large attenuation differences that make neutron radiography useful, usually providing almost a reversal of typical x-ray attenuation. In many cases radiographs taken with both x-rays and neutrons provide complementary information about the object. Neutron radiography has also been done with cold neutrons. These very slow neutrons have energies below 0.005 eV. Greater radiographic contrast can often be obtained with these special neutrons. Sometimes the term slow neutrons is used to designate the cold and thermal neutron region and beyond, up to energies of several keV. In addition, use has been made of epithermal neutrons (energy range slightly higher than thermal, typically above 0.5 eV, up to about 10,000 eV) and fast neutrons, which include energies above 10,000 eV, up to the MeV energy range. Neutrons with energies above 10 MeV are often termed relativistic because of the high velocities of these neutrons. Radiography has been done in all these energy ranges but thermal neutrons are most widely used. Table 1.1 contains a brief description of the energy ranges for neutrons and the properties.

Table 1.1. Neutrons Classified According to Energy

Term	Comments	Energy Range
Slow		0.00 eV to 1,000 eV
Cold	Materials possess high cross-sections at these energies, which decrease the transparency of most materials but also increase the efficiency of detection. A particular advantage is the reduced scatter in materials at energies below the Bragg cutoff.	Less Than 0.005 eV
Thermal	Produced by slowing down of fast neutrons until the average energy of the neutron is equal to that of the medium. Thermal neutrons provide good discriminatory capability between different materials; sources are readily available.	0.5 eV to 0.5 eV
Epithermal	Produced at energies greater than thermal, e.g. fission energies and surrounded by a moderator. Neutrons are slowed down until they have energies in thermal equilibrium with the moderator molecules. At any location where thermal equilibrium has not been achieved the distribution of neutron velocities will contain velocities that exceed that permitted by a Maxwellian distribution of the moderator temperature. Such neutrons are referred to as epithermal neutrons.	0.5 eV to 10^4 eV
Resonance	Certain nuclei exhibit strong absorption characteristics at well-defined energies called resonance absorptions. Neutrons in these specific energy ranges are referred to as resonance neutrons and provide excellent discrimination for particular materials by working at energies of resonance. Greater transmission and less scatter occur in samples containing materials such as hydrogen and enriched reactor fuel materials.	1 eV to 100-1,000 eV
Fast	Fast neutrons provide good penetration. Good point sources of fast neutrons are available. At the lower energy end of the spectrum fast neutron radiography may be able to perform many inspections performed with thermal neutrons, but with a panoramic technique. Poor material discrimination occurs, however, because the cross-sections tend to be small and similar.	1,000 eV to 20 MeV
Relativistic		More than 20 MeV

The neutrons may be produced by an isotopic source, an accelerator, or a nuclear reactor and may be imaged by a variety of methods. Unlike other forms of penetrating radiation, the neutrons must be converted into other forms of radiation (light, alpha particles, beta particles, gamma rays, etc.) before being detected by a photographic emulsion or other devices.

1.4 Advantages

Neutron radiography complements X- and gamma radiography in many cases. While X- and gamma radiation are typically used to image high atomic number materials such as lead or steel by themselves or in low atomic number matrices such as plastic or rubber, neutron radiography best images low atomic number materials such as paper, plastic or rubber in a matrix of a high atomic number material such as lead or steel. As such, neutron radiography finds application to the detection of low atomic number materials such as "O"-rings, gaskets, adhesives or sealants, hydrogenous liquids like water or petroleum products and corrosion. A major neutron radiographic application has been the detection and characterization of explosives inside metal containers destined for critical aerospace and military service. Examples include verification of the explosive in explosive bolts, lines or detonating cord used to separate components in flight or space.

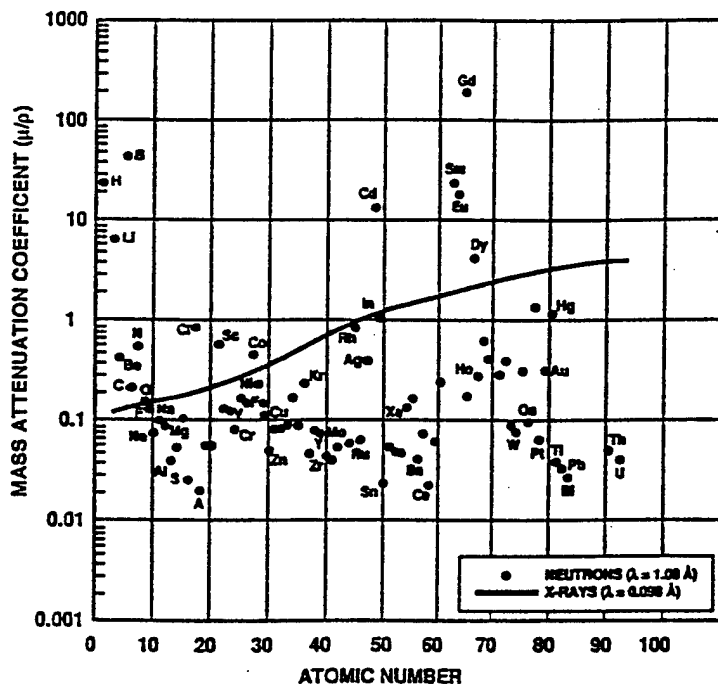

Figure 1.1. A comparison of mass attenuation coefficients for the elements for both medium energy x-rays (about 125 kV, solid line) and thermal neutrons (dots). This curve reproduced from Ref. 12, is based on an earlier version, by Thewlis (33).

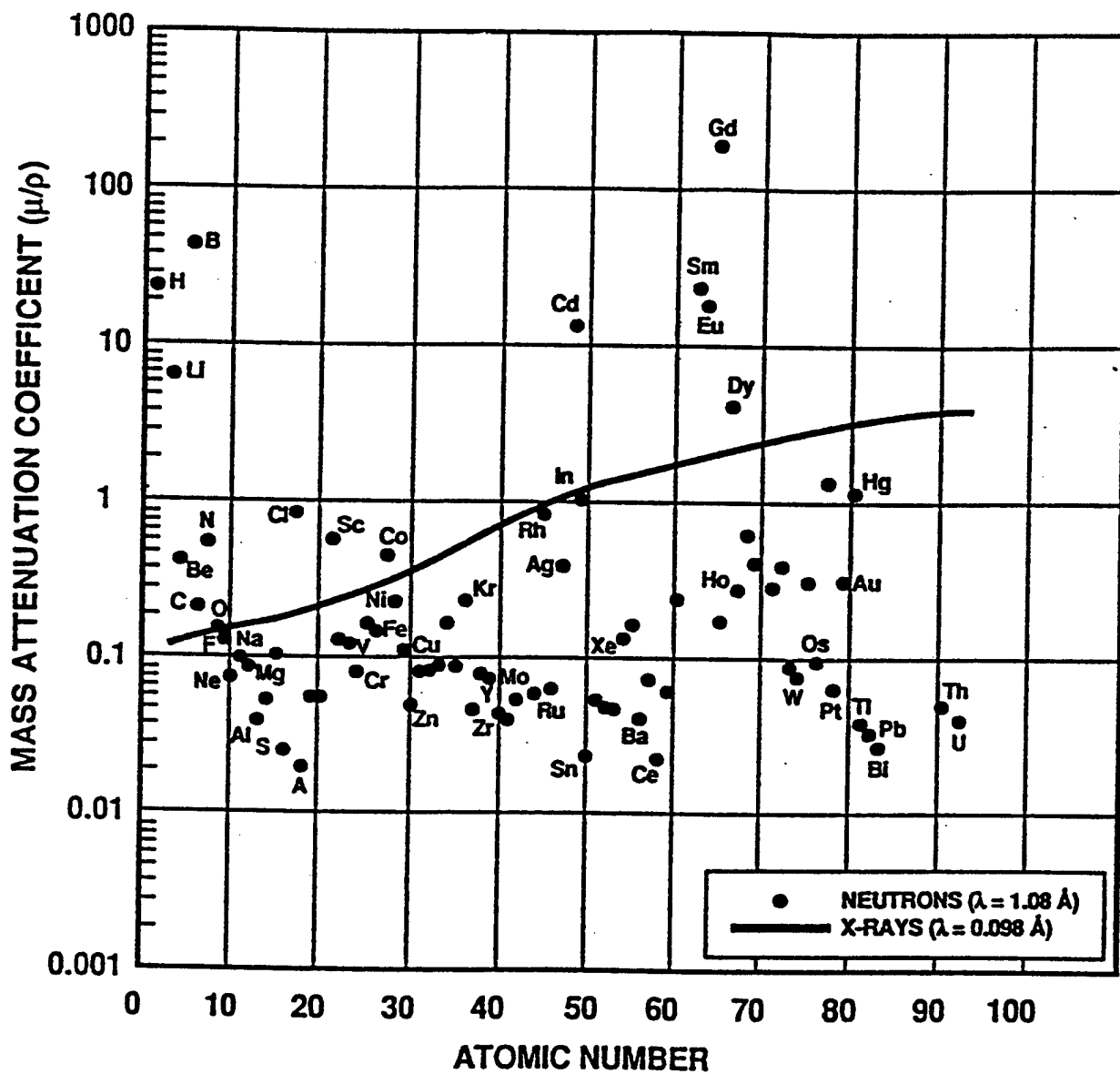

Figure 1.1. A comparison of mass attenuation coefficients for the elements for both medium energy x-rays (about 125 kV, solid line) and thermal neutrons (dots). This curve reproduced from Ref. 12, is based on an earlier version, by Thewlis (33).

In addition to the applications that follow the sensitivity for the low atomic number materials, neutron radiography can be used to distinguish between certain materials with similar atomic numbers or even between different isotopes of an element. The property of importance is the ability to either scatter or absorb neutrons (e.g. to remove neutrons from the imaging beam). Scattering of neutrons from a beam is best accomplished by low atomic number materials; i.e., hydrogen and carbon, as examples. Absorption of the neutrons is a property related to the structure of the nucleus of the atom and is not a function of atomic number as is the absorption of X- and gamma rays (see Figure 1.1). This property provides for radiographic distinction between metals such as cadmium and iron or silver, rare earth metals such as gadolinium, samarium, europium, or dysprosium versus other rare earth metals, and iron, cobalt, and nickel versus lead, tungsten or bismuth.

An additional advantage is the ability to perform isotopic separation; i.e., that is the ability to image one isotope of an element in the presence of other isotopes of the same element. An example of this application that has proved useful is the radiography of nuclear fuels to image the fissionable U-235 content rather than the U-238 that is most prevalent in natural uranium. In addition, other isotopes such as Cd-113, a material sometimes used in reactor control rods, can be imaged in the presence of other, less neutron absorbing cadmium isotopes.

Radiography of nuclear fuel is an example of another advantage of neutron radiography, the ability to radiograph intensely radioactive materials. The radiation released by irradiated nuclear fuel would quickly overexpose radiographic film used for X- or gamma radiography. Neutron radiography of radioactive objects is commonly done by neutrons which have passed through a specimen to produce a radioactive image on metal converter foils such as indium, dysprosium, silver or gold. The exposed, radioactive converter screen is removed from the intense radiation area of the fuel rod after neutron exposure and placed in a film loaded cassette where the radioactivity induced in the screen by the neutrons exposes the film. The latent image on the film produced by this "indirect" technique comes from the beta particles or gamma rays released by decay of the radioactive atoms produced by neutron absorption. The film is an **autoradiograph** of the converter screen and a neutron image of the inspection object without the fogging that might have been caused by the intense radioactive emissions.

1.5 Limitations

Radiation safety precautions must be used with neutron inspection techniques as is necessary with other forms of radiation testing; i.e., there is a potential radiation hazard that requires practitioners be well informed, properly equipped and organized to handle radiation and radioactive materials. The neutron radiographer needs formal training and experience that is not satisfied by training and experience with X- or gamma radiography (although training for X- and gamma radiography is an excellent start). A similar, or more extensive, radiation safety program is required as compared to X- and gamma radiography. The dosimetry used, such as survey

meters, area monitors and personnel dosimeters must be sensitive to neutrons. In addition, care must be taken with all components that have been exposed in the neutron beam, including the beam stop, cassettes and the inspection object, all of which may exhibit some level of radioactivity caused by neutron activation. The radiation level is usually small because the neutron intensity used for radiography is relatively low as compared to that deliberately used to make objects radioactive (for activation analysis, for example) and the exposure time is usually short, meaning that long-lived activities are usually not a significant problem. The radiographer should be aware that neutron techniques create some radiation safety problems beyond those encountered with gamma or x-ray techniques. There are other differences. For example, film cassettes made from paper or plastic are not satisfactory because those materials attenuate neutrons. Aluminum is often used for neutron cassettes. Different intensifier or converter screens are needed. The typical lead screens are usually replaced by a screen of gadolinium or other materials as discussed in Section 4.

The neutron sources are discussed in Section 3. Typical sources for neutron radiography include isotopes, accelerators and reactors. These tend to be more expensive than those used for X- or gamma radiography. This is particularly true if large, high output sources are desired to permit rapid, good resolution neutron radiographs to be made. Properly collimated and shielded isotopic sources may easily cost \$100,000, while large accelerators and reactors will cost from about \$500,000 to well over \$1,000,000, plus the cost of a building or specially shielded laboratory. The availability of neutron radiography to those wishing to purchase the service rather than set up their own laboratory may not be as convenient as that for X-radiography. A neutron radiography customer must often ship specimens to a distant facility with the attendant extra costs and time lost.

There are portable, or more correctly, transportable neutron sources available. Some are low flux (neutron intensity) devices. As such, producing neutron radiographs can be a slow process, often providing only moderate resolution images. Some progress is being made with transportable isotopic and accelerator sources used with electronic imaging systems that improve the situation (28, 29, 30). However, the process is still often slower as compared to the equivalent portable X- and gamma radiographic techniques.

Just as facilities for performing neutron radiography are still few in number, the lack of experienced personnel contributes to the problem. The American Society for Nondestructive Testing has recognized neutron radiography as a technique of major importance by setting up a recommended practice for neutron radiography which includes suggested training and experience for individuals who want to perform in the field. Only a small number of people have been certified as Level III in neutron radiography as compared with the other recognized NDT fields.

1.6 Historical Development

The earliest research on neutrons for radiography was the work of Kallmann and Kuhn in

Germany, in 1935. This pioneering work resulted in numerous patents and one publication which was held up until after World War II (31). Kallmann used an accelerator source with a neutron yield of about 4×10^7 neutrons per second. This low output source necessitated the use of long exposures, about 4 hours per radiograph. Peter's early neutron radiographic work in Germany made use of a more intense accelerator source that permitted a neutron radiograph to be made in a few minutes (32).

The first reactor neutron radiographic work published was by Thewlis in 1956 (33). Thewlis and his co-worker Derbyshire used the BEPO reactor at Harwell in England. The reactor neutron radiographs, made with the better collimated and more intense neutron source, produced very good quality images as compared to the earlier accelerator neutron source radiographs. Thewlis also pointed the way for practical applications of neutron radiography.

As neutron sources became more available in the 1960's, more neutron radiographic work was reported with emphasis on both techniques and applications. Extensive developments of techniques and applications were reported by many investigators during the 1960's. Some of that work was stimulated by the 1965 publication of a book on neutron radiography (12). Early work on neutron radiography in the United States was summarized in a 1991 review article (34).

By the beginning of the 1970's there were approximately 40 installations at which neutron radiography was being performed. Developments in the 1970's are summarized in several reviews of that period (13, 14, 15). World-wide facilities for neutron radiographic work numbered over 100, as reported at a 1995 international conference (35).

2.0 THEORY

2.1 Neutron Production Principles

Neutron production for neutron radiography may be accomplished using radioisotope sources, accelerators, or nuclear reactors. Generally speaking, the intensity of thermal neutron beams for radiography is greatest for reactor systems, followed by lower intensity beams from accelerator and radioisotope sources. There are exceptions to that generalization. The cost of neutron sources tends to follow the same order, with reactor sources being priced higher, typically at well over a million dollars.

Sources of neutrons usually provide fast neutrons. These fast neutrons must be slowed down, a process called moderation or thermalization, if the neutrons are to be used for thermal neutron radiography and take advantage of the attenuation differences previously shown in Figure 1.1. Moderators, materials that usually surround a fast neutron source to create a source of thermal neutrons, are typically made of low atomic number material such as hydrogen or carbon. Water and hydrocarbon materials such polyethylene are often used, in sizes approaching a cubic meter. The fast neutrons lose energy by collisions with the moderator material, eventually coming into "thermal equilibrium" with the moderator, hence the term thermal neutrons. The higher the neutron energy, the more difficult the moderation process becomes, because more scattering reactions must be used. As a rule of thumb, the fast neutron yield in neutrons/second (n/s) is reduced by a factor of 100 to 1,000 for the peak thermal neutron flux within the moderator. Collimation, that is bringing a useful beam out of the large moderator, will further reduce the neutrons available in a beam for radiography. The total reduction from the neutron yield in terms of n/s to a thermal neutron radiographic beam in terms of n/cm²-s can be a million times or more (36).

2.2 Neutron Energies

As noted in the preceding sections, neutrons normally possess large kinetic energies when they are produced. However, for neutron radiography and many other applications, neutrons with very low or thermal energies are most useful. Thermal neutrons are neutrons that possess a kinetic energy related to the temperature of their surroundings; i.e., at 20°C the (thermal) neutron would have a kinetic energy of 0.025 eV. These low kinetic energy neutrons are also called 'slow' neutrons although they are traveling at a velocity of 2200 meters/s.

To thermalize or slow down a neutron, the neutron is allowed to move through a low atomic number substance such a water, graphite, or beryllium. Collisions of the neutrons with the low atomic number materials, especially hydrogen, reduce the neutron's kinetic energy by transfer of

their kinetic energy to the nuclei of the atoms. Hydrogen is most effective because it has a nucleus with essentially the same mass as the neutron. Hydrogen is also effective because it has a low probability of thermal neutron absorption.

Neutrons with sufficient energy to be transmitted through thin cadmium foil are called epithermal or epithermal neutrons and have kinetic energies greater than 0.5 eV. Neutrons with energies above the cadmium cutoff energy of 0.5 eV and below approximately 10 keV are called epithermal neutrons (although other energies are sometimes used as separation points). Neutrons with kinetic energies above 10 keV are referred to as fast neutrons. Neutrons with energies below about 0.005 eV are designated as cold neutrons and require moderators cooled to liquid nitrogen or lower temperatures. Refer to Table 1.1 for additional information.

As the kinetic energy of the neutron decreases, the probability of its absorption in a nucleus increases. This probability is called the microscopic cross section of the nucleus and is given in units of area such as square centimeters (37). Cross section is not a real area but rather an effective area represented by the probability of the neutron interaction. An example is the cross section of Boron-10 for thermal neutrons of 3,838 barns (a barn is equivalent to 10^{-24} square centimeters) while the cross section of Boron-11 is only 5 millibarns. Obviously there is not six orders of magnitude difference in the areas of the two nuclei but there is six orders of magnitude difference in the probability of neutron interaction by the two nuclei. Cross section varies widely with structure of the nucleus, energy of the neutron, and reaction between the neutron and nucleus.

2.3. Neutron Interactions, Scattering, Nuclear Absorption, Fission

A brief discussion of neutron interactions is important to understanding how neutrons may be used for radiography. Concepts, which include shielding, detection, thermalization or moderation, and collimation, depend upon how neutrons interact with materials. Neutron interactions of most importance are scattering, nuclear absorption, and fission. Each of these is discussed briefly below. Additional background information can be found in textbooks on nuclear physics or nuclear engineering (38-42).

Scattering

Scatter is an important way for neutrons to be removed from a beam and to lose kinetic energy (become thermalized or moderated). Neutron scattering occurs when neutrons collide with the nuclei of atoms. Note that neutrons pass through the electron clouds surrounding atoms without detectable interaction. Interactions are with the nuclei of the atoms. Neutrons may scatter from interaction with a nucleus in either an elastic or inelastic fashion.

When a neutron undergoes elastic scattering it is as if the neutron and the nucleus were "billiard balls." The initial energy of the neutron (assuming the nucleus is at rest) is distributed between the neutron and nucleus according to the laws of conservation of kinetic energy and momentum.

This distribution will depend on the mass of the nucleus and the angle of scatter. The recoil energy of the nucleus results in heating of the moderator. This mode of interaction is particularly important for lower energy neutrons and interactions with low atomic number nuclei, where a neutron can lose a significant fraction of its energy in a single collision. Inelastic scatter occurs when the initial energy of the neutron is sufficient to "excite" the nucleus to an allowed quantum energy level above the ground state. The difference in energy between the ground state and the excited state is no longer available to the scattered neutron and recoil nucleus. The kinematics (energy, momentum and scattering angles) of the collision are then determined with this reduced energy. The excited nucleus returns to the ground state via emission of one or more gamma photons. Inelastic scatter becomes more important as neutron energies increase or the atomic number of the target nuclei increase.

Nuclear Absorption

Neutrons may enter the nucleus of an atom quite easily, as compared to charged particles since there is no coulomb or charge repulsion to overcome. If the neutron remains in the nucleus, excess energy (binding energy) or particles must be released from the nucleus. For a thermal neutron, this energy release most likely occurs in the emission of a photon from the nucleus. Such reactions are designated as (n,γ) , capture, or activation reactions. The product of an (n,γ) (pronounced n-gamma) reaction is most often, but not always, unstable or radioactive. As neutron energy increases above thermal energies, the probability of an (n,γ) reaction decreases.

At higher kinetic energies, absorption of the neutron by a nucleus is followed by the release of a proton, an alpha particle, or two or more neutrons. These reactions are often designated: (n,p) , (n,α) , and $(n,2n)$. Probabilities for these reactions vary widely with the structure of the target nucleus but generally increase with increasing kinetic energy of the neutron. Products of these reactions are often radioactive.

Fission

Fission occurs when a neutron with the proper energy enters a nucleus causing it to split into two smaller nuclei. Uranium-235, Plutonium-239, and Thorium-233 fission upon absorption of a thermal neutron. Uranium-238 will fission after the absorption of a fast or high energy neutron. Californium-252 is already unstable and will spontaneously fission; i.e., will fission without the necessity of a neutron being absorbed to initiate fission. The products of each fission are two smaller (radioactive) nuclei and 2 to 3 free neutrons, on average. The neutrons are released with an average energy of over 2 MeV and generally must be slowed down; i.e., thermalized, to be used for either additional fission reactions or for neutron radiography.

Mathematical Relationships

- (1) The following equation can be used to determine the approximate intensity of a parallel neutron beam traversing a material of thickness d .

$$I = I_0 e^{-N\sigma d} \qquad \text{Eqn. 2.1}$$

This equation assumes a point detector, monoenergetic neutrons and interaction (absorption or scatter) that removes the neutron from the beam. The quantities are defined below:

- I** is neutron intensity with absorber thickness **d**
- I₀** is neutron intensity with no absorber
- N** is atoms per cubic centimeter (cc) in absorber
- σ** is the total microscopic cross section of atoms in this absorber (cm²)
- d** is thickness of absorber (cm)

For thick absorbers, a build-up factor of (**B**) is used to account for neutrons scattered into the point of neutron detection.

$$I = B I_0 e^{-N\sigma d} \quad \text{Eqn. 2.2}$$

B is approximately 5 for thick absorbers containing hydrogen.
The macroscopic cross section (**Σ**) is defined as:

$$\Sigma = N\sigma \quad \text{Eqn. 2.3}$$

and carries units of reciprocal length. The macroscopic cross section is the probability of interaction per unit length and may be substituted in the above equations to give:

$$I = I_0 e^{-\Sigma d} \quad \text{and} \quad I = B I_0 e^{-\Sigma d} \quad \text{Eqn. 2.4}$$

(2) Materials irradiated with neutrons can become radioactive. The following equation can be used to estimate the level of activity:

$$A = N \sigma \phi (1 - e^{-0.693 t/T}) \quad \text{Eqn. 2.5}$$

where the quantities are defined below:

- A** is the activity in disintegrating atoms per second at the end of neutron irradiation
- N** is the total number of target atoms of the isotope involved in the neutron reaction
- σ** is the absorption microscopic cross section for the isotope and neutron reaction under consideration (cm²)
- φ** is the neutron flux in n cm⁻² sec⁻¹
- t** is the time of neutron irradiation
- T** is the half life of the radioisotope produced.

This takes into account that the radioactive nuclei decay while they are being produced and assumes that the neutron flux is not appreciably reduced in travel through the material. For thick absorbers this correction must be made. After the material is removed from the neutron environment there is no further production and the activity will decay according to the half-life.

2.4 Radioisotope Sources, Accelerator Sources, Nuclear Reactors

Various sources for neutron radiography are briefly described. Major categories of sources are radioisotopes, accelerators and nuclear reactors.

Radioisotope Sources

There are two types of radioisotope sources, those that depend on fission and those that require a radiation such as alpha particles or gamma rays incident on an appropriate target nucleus. An example of the first type is Cf-252 which spontaneously splits apart in a fission reaction. The other type involves combinations of alpha (or gamma) emitting radioisotopes with an element such as beryllium. The alpha emitting types are important for the latter category.

Cf-252, which spontaneously undergoes a fission reaction that releases neutrons, has become one of the major radioisotope neutron sources because it offers a reasonably long half life (2.6 years), produces a moderate energy neutron (fission spectrum with a neutron average energy of about 2.3 MeV), and a relatively high yield, typically 100 times as many neutrons emitted per gram, as compared to other radioisotope sources. Californium is a man-made element. The Cf-252 isotope has been available at a moderate cost (\$10 to \$20 per microgram.) However, the cost of these sources is high because encapsulation, moderation, collimation and shipping far outweigh the cost of the source material. It has been used where cost was less important than portability and neutron output. For example, the robotic neutron system at McClellan Air Force Base, used for on-aircraft inspection, made use of Cf-252 as the neutron source (29).

An advantage of the Cf-252 source is the ease of moderating the fast neutrons to produce a beam of thermal neutrons. Moderation is somewhat easier because the small source size means that the moderator material can closely surround the source and because the energy of the emitted neutrons is reasonably low (fission spectrum with an average energy of about 2.3 MeV). The high neutron yield, coupled with a thermalization factor of 100 or less (the ratio of the fast neutron yield to the peak thermal neutrons per square cm-second in the moderator, see Ref. 35) means that a 1 milligram source (fast neutron yield of 3×10^9 n/s) could produce a peak thermal neutron flux in a well designed moderator of about 3×10^7 n/cm²-s and, with collimation losses, perhaps a crudely moderated radiographic beam of 10^3 to 10^4 n/cm²-s.

Alpha emitting radioisotope sources mixed with beryllium have been used as neutron sources since the 1930's. They offer a great variety of source materials and therefore a variety of costs, half lives and outputs. Short lived alpha emitters such as Po-210 (138 days) or Cm-242 (163

days) offer a neutron yield per gram of about 1/100 that of Cf-252 while longer lived sources such as Pu-238 (89 years), Am-241 (458 years), and Ra-226 (1620 years) are another factor of 100 lower in neutron output (less than 1×10^8 neutrons per second per gram.) Where such low output can be utilized, these sources have been used for neutron radiography but a source yield of at least 10^9 fast neutrons per second is usually considered to be necessary for reasonable thermal beam intensities. Such large radioisotope sources are usually difficult to handle and expensive.

Photoneutron or photodisintegration sources, such as gamma emitting radioisotopes mixed with or designed to irradiate beryllium or deuterium oxide (heavy water) have been used but have been largely abandoned because they produce a high gamma radiation background. Examples of photoneutron sources include mixtures of Sb-124 with Be or Na-24 with Be or heavy water. See Table 2.1 for examples of isotopic sources.

Table 2.1 Typical Radioisotope Sources

<u>Source</u>	<u>Reaction</u>	Average Neutron		<u>Neutron Yield</u> n/s per gram	<u>Gamma Dose</u> R/hr at 1m*
		<u>Half live</u>	<u>Energy</u> (MeV)		
Cf-252	Spontaneous fission	2.6 years	2.3	3×10^{12}	2.9
Am-241/Be	(α ,n)	458 years	4	1×10^7	2.5
Pu-238/Be	(α ,n)	89 years	4	4.7×10^7	0.4
Sb-124/Be	(γ ,n)	60 days	0.024	2.7×10^9	4.5×10^4

*Gamma dose is rads/hr at 1m, normalized to neutron yield of 5×10^{10} n/s.
100 rads is equivalent to 1 gray.

Accelerator Sources

Accelerator sources of neutrons usually offer the advantages of higher output over isotope sources together with the ability to turn the radiation on and off. Neutron yields begin at about 10^7 n/s and may be as high as 10^{12} n/s. One of the less expensive neutron accelerators is the Cockcroft-Walton accelerator (43) which can produce neutrons through either the (d,D) or (d,T) reactions at moderate accelerating potentials (from 100 to 400 KeV). In both reactions deuterium is ionized and the deuterons are accelerated toward targets of deuterium for the (d,D) reaction and targets containing tritium for the (d,T) reaction. The (d,D) reaction produces neutrons with an energy of about 2.5 MeV while the (d,T) reaction produces neutrons with an energy of about 14 MeV. The 14 MeV neutrons are more difficult to slow down to thermal energies (moderate) but the reaction yield at 150 keV is 60 times better. The (d,T) source has been a widely used source for thermal neutron radiography because of the high neutron yield. Typically the neutron

generators have been used with a sealed neutron tube to avoid tritium radiation safety problems. Neutron yields decrease with time because of tube gassing problems and depletion of the tritium as it is bombarded by the deuteron beam. Some machines use a mixture of deuterium and tritium to ionize and accelerate into the target to help reduce target depletion. Modern versions of these accelerators can easily be used in a laboratory or fixed radiographic facility and are also designed to be transportable for mobile or field inspection applications (44, 45).

New types of accelerators have been developed as sources for neutron radiography. These include modern radio frequency quadrupole accelerators (28,30,35,46) and cyclotrons (47). Both types of accelerators make use of neutron reactions such as protons on beryllium targets. These relatively expensive machines can produce very high intensity beams for neutron radiography, typically $10^6\text{n/cm}^2\text{-s}$, in well collimated beams.

A new accelerator source based on the spallation process, is now being used for neutron radiography. This fixed installation source designed for research applications is capable of producing extremely well collimated thermal neutron radiographic beams of high intensity. Beam characteristics have been described to produce a useful thermal neutron flux of $5 \times 10^6\text{n/cm}^2\text{-s}$ at the unusually large L/D of over 500 (48).

Van de Graaff accelerators have been used for neutron production. Again, the (d,D) and (d,T) reactions may be used with the (d,D) reaction being favored because neutron yield increases with increasing acceleration voltage while the yield of the (d,T) reaction decreases above about 400 keV. A well used reaction for Van de Graaff generation of neutrons is the acceleration of deuterons into beryllium targets. Large Van de Graaff machines can produce useful beams of thermal neutrons for radiography; beam intensities of more than $10^6\text{n/cm}^2\text{-s}$ have been obtained (49).

Machines designed for production of high energy x-ray photons may also produce neutrons by allowing the photons to interact with either beryllium or uranium-238 metal. Relatively high yield and long target life are characteristic of this type of production but the Linac type of accelerators also produce an intense x-ray background which can make it difficult to perform neutron radiography.

Nuclear Reactors

Small research reactors which fission uranium-235 to produce neutron flux in the range of 10^{11} to 10^{13} neutrons per square centimeter per second have been used very successfully for neutron radiography. While the source cost is high, the cost per neutron is less than for isotope or accelerator sources. The high neutron fluxes, 100 to 1000 times that of isotope or accelerator sources, permit very high quality neutron radiographic imaging with the short exposure times. Reactors do not offer the advantage of portability and are subject to regulation (50).

Uranium neutron multipliers called sub-critical assemblies have been used for neutron radiography. The sub-critical assembly resembles a reactor in that uranium fission produces most of the neutrons. However, the sub-critical assemblies cannot reach the condition of producing a

self-sustaining fission reaction. The assemblies produce multiplications of the neutrons from other neutron sources such as Cf-252. A multiplication of about 30, a significant increase in the number of neutrons available for radiography, can be obtained. A source of this type was used for many years to inspect critical weapon components (51, 52).

2.5 Neutron Detection, Converter Screens

Neutron detection, for the purpose of radiography, is complicated by the need to convert the neutron to other types of radiation. The neutron is very difficult to detect by 'direct' interaction of the neutron with matter. However, the secondary radiation (photons, protons, and alpha particles) and decay of the radioactive nuclei produced by neutron absorption offer adequate and sometimes advantageous means for neutron detection.

Converter screens are more important for neutron radiography than for X-ray or gamma radiography. Film is more sensitive to the photon radiation than to the neutrons. Film is very sensitive to the secondary radiation produced by the neutrons. The neutron radiography

converter screens utilize the secondary radiation from neutron absorption or the decay radiation from radioactive products of neutron absorption. The prompt emission types of converter screens are used for direct neutron radiography. Screens that tend to become radioactive are used for transfer or indirect neutron imaging.

Typical thermal neutron converter screen materials are summarized in Table 2.2.

Converter Screens for Direct Neutron Radiography

Direct neutron radiography places the specimen, converter screen and film (or other imaging system) in the neutron beam at the same time as illustrated in the upper part of Figure 2.1. The converter screen changes the neutrons that have been transmitted through the specimen into radiation that can be detected by

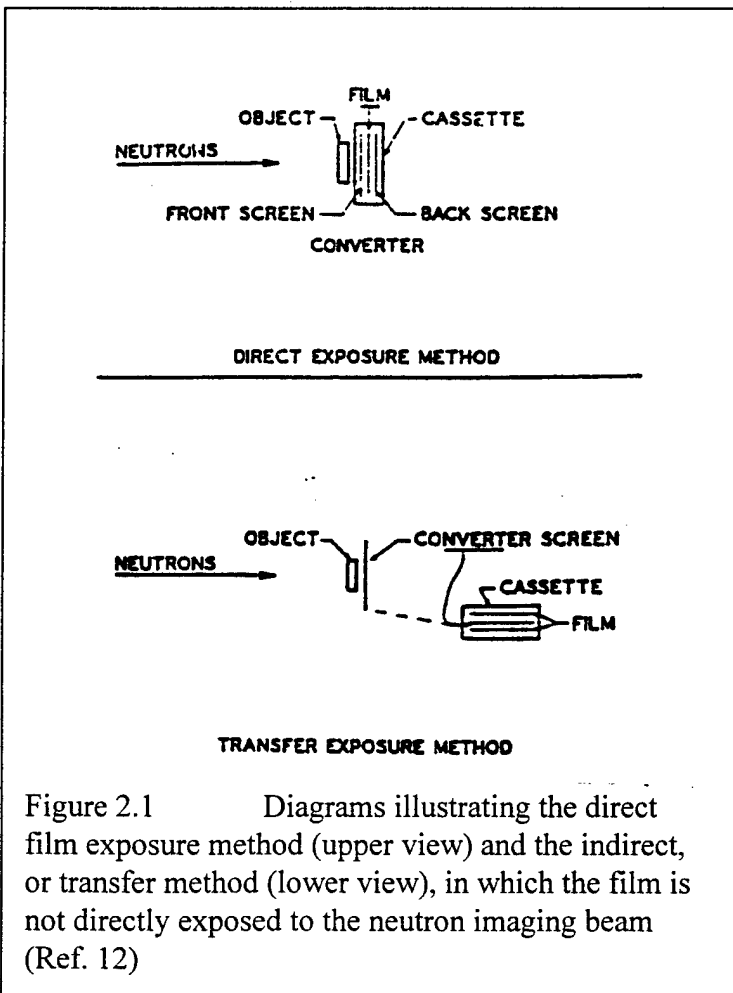

Figure 2.1 Diagrams illustrating the direct film exposure method (upper view) and the indirect, or transfer method (lower view), in which the film is not directly exposed to the neutron imaging beam (Ref. 12)

TABLE 2.2 Examples and Characteristics of Neutron Converter Screen Materials

Material	Isotope	Abundance (%)	Reaction	Thermal Neutron Cross Section (barns)	Half Life (#)	Use (*)
LiF	Li-6	7.5	${}^6\text{Li}(n,\alpha){}^3\text{H}$	940	NA	D,R
H ₃ BO ₃	B-10	19.8	${}^{10}\text{B}(n,\alpha){}^7\text{Li}$	3838	NA	D
Metal	Rh-103	100	${}^{103}\text{Rh}(n,\gamma){}^{104}\text{Rh}$	140	42s	D
			${}^{103}\text{Rh}(n,\gamma){}^{104\text{m}}\text{Rh}$	11	4.5m	D,I
			${}^{103}\text{Rh}(n,n'){}^{103\text{m}}\text{Rh}$	--	57m	D,I
Metal	Ag-107	51.8	${}^{107}\text{Ag}(n,\gamma){}^{108}\text{Ag}$	37	2.4m	D
	Ag-109	48.2	${}^{109}\text{Ag}(n,\gamma){}^{110}\text{Ag}$	170	24.5s	D
			${}^{109}\text{Ag}(n,\gamma){}^{110\text{m}}\text{Ag}$	4	254d	I
Metal	Cd-113	12.3	${}^{113}\text{Cd}(n,\gamma){}^{114}\text{Cd}$	19,600	NA	D
Metal	In-115	95.7	${}^{115}\text{In}(n,\gamma){}^{116}\text{In}$	155	54m	D,I
			${}^{115}\text{In}(n,\gamma){}^{116\text{m}}\text{In}$	42	14s	D
Metal or Oxide	Sm-149	13.8	${}^{149}\text{Sm}(n,\gamma){}^{150}\text{Sm}$	42,000	NA	D
	Sm-152	26.7	${}^{152}\text{Sm}(n,\gamma){}^{153}\text{Sm}$	210	47h	D
Metal or Oxide	Eu-151	47.8	${}^{151}\text{Eu}(n,\gamma){}^{152\text{m}}\text{Eu}$	3,200	9.2h	D,I
Metal or Gadolinium Oxysulfide	Gd-155	14.9	${}^{155}\text{Gd}(n,\gamma){}^{156}\text{Gd}$	61,000	NA	D,R
	Gd-157	15.7	${}^{157}\text{Gd}(n,\gamma){}^{158}\text{Gd}$	255,000	NA	D,R
Metal or Oxide	Dy-164	28.2	${}^{164}\text{Dy}(n,\gamma){}^{165}\text{Dy}$	900	2.35h	D,I
			${}^{164}\text{Dy}(n,\gamma){}^{165\text{m}}\text{Dy}$	1800	1.25m	D
Metal	Au-197	100	${}^{197}\text{Au}(n,\gamma){}^{198}\text{Au}$	98.8	2.695d	D,I

NA in those cases in which emission used for film exposure is "prompt" or emitted immediately after neutron interaction

* D (Direct) - screen and film together during neutron exposure

I (Indirect or Transfer) - screen exposed without film in the neutron beam and then transferred to the film after exposure

R (Real time) - screen used with an image intensifier to produce real time or CRT images

the film. Converter screens for this type of neutron radiography are selected from materials that undergo prompt reactions upon neutron absorption, materials such as gadolinium or cadmium, for example. Materials that exhibit radioactive reactions with short half-lives can also be considered for direct neutron radiography; materials such as silver or rhodium converter screens are good examples of short lived radioactive converter materials.

Direct converter screens also make use of the conversion of the neutron to alpha particles by either Boron-10 or Lithium-6. The alpha particles have a very short range so few would escape a converter screen having a thickness adequate for normal handling. Instead, the alpha particles are usually combined with a phosphor so the screen emits light upon neutron absorption. A popular high sensitivity screen has been made by mixing lithium fluoride enriched in Lithium-6 with scintillation grade zinc sulfide. The scintillation screens are used with film sensitive to the light emitted from the screen. The scintillation screen and alpha emitter combinations produce much faster results, exposures 100 times or more shorter exposures as compared to the typically used screens of gadolinium. Since the scintillation screen images are produced with fewer neutrons, the images are often grainy or mottled as compared to metal converter screen images.

Some special plastic materials such as nitrocellulose and polycarbonates can produce images from exposure to the alpha particles. The alpha particles produce damage in the plastic that can be attacked by chemical agents. Such materials are identified as track-etch films. An advantage of the track-etch method is insensitivity to gamma radiation (one major application of track-etch is radiography of irradiated, radioactive nuclear fuel). It is also convenient to work with these materials in the light without the need for a darkroom. The alpha particle track-etch method also offers images with good spatial resolution because of the short range of the charged alpha particle.

Converter Screen for Indirect Neutron Radiography

Indirect or transfer neutron radiographic screens use the decay of radioactive products formed in the converter screen. The indirect technique places only the specimen and converter screen together in the neutron beam. After exposure to the neutrons, the screen is removed from the neutron beam and placed in contact with film to produce the radiograph, as shown in the lower part of Figure 2.1. The film will be exposed to the radiation that results from the decay of the radioactive isotope(s) produced in the screen during neutron exposure. Indirect neutron radiography offers a method to radiograph highly radioactive specimens that would produce exposure of the film if it were present during the radiographic exposure. The indirect technique is usually slower than the direct film method, since two exposures are required, one in the beam to produce the radioactive image and one on the film to produce the autoradiograph.

Converter Screens for Neutron Radioscopy (Real-Time Imaging)

Thermal neutron image intensifiers have been used to convert an incoming thermal neutron image into a bright light image that can be detected by a sensitive TV camera, a technique similar to that used for x-radioscopy. To best utilize the image intensifier, the converter screens involve scintillation which is excited by the alpha emission from lithium or boron, often combined with

an efficient phosphor, such as ZnS. The phosphor gadolinium oxysulfide offers high sensitivity to thermal neutrons because of the very high neutron cross section of gadolinium.

With the availability of modern, sensitive charged coupled device (CCD) cameras, many neutron radioscopic systems now use a sensitive scintillator or fluorescent screen observed by a CCD camera through a turning mirror (to place the camera out of the direct radiation beam). A typical radioscopic camera system is shown in Figure 2.2. Optics between the screen and optional image intensifier and camera are not shown. Many of these scintillator-CCD camera systems use the neutron scintillator LiF-ZnS(Ag), enriched in Li-6. The alpha emission excited by neutron absorption in the Li-6 nucleus, and the companion triton both contribute to light emission from the ZnS phosphor. These digital systems can offer large area coverage, wide dynamic range and good spatial resolution (28, 29, 30, 47, 48).

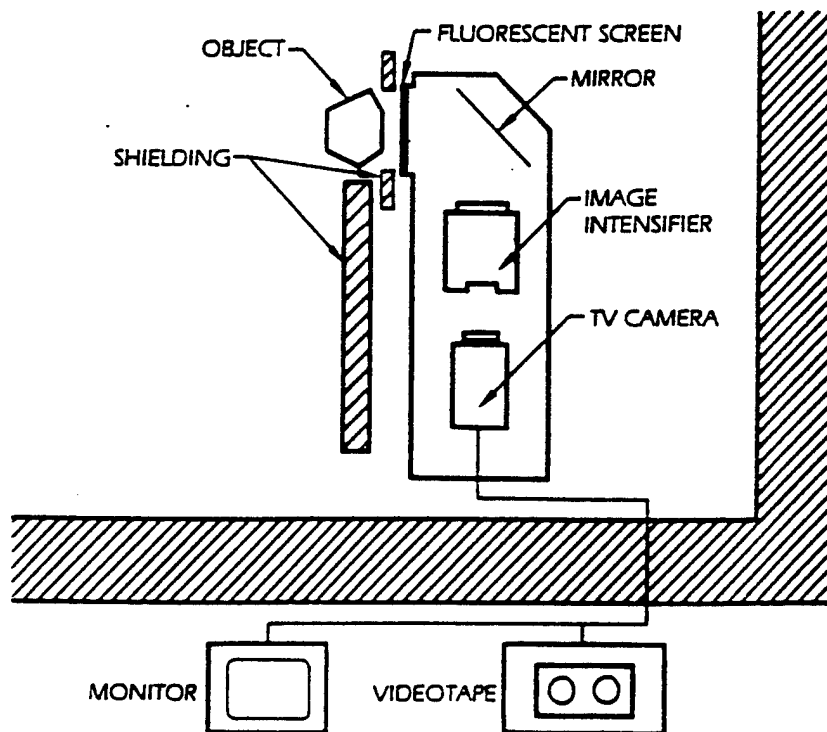

Figure 2.2 Diagram of typical radioscopic imaging system. The turning mirror removes the camera from the direct radiation beam. The image intensifier is optional; optics are not shown. The CCD camera is often used in neutron radioscopic systems.

2.6 Neutron Shielding

As with any other application of penetrating radiation, precautions must be taken to prevent overexposure of personnel to the radiation. The same concepts of radiation safety as with X-ray and gamma radiography are useful for neutron radiography: time, distance, and shielding (53, 54). An important difference for neutron radiography is the shielding. While lead is an excellent shield for the photon radiation, it is poor for neutron radiation. Neutron shields are constructed of concrete, tanks of water or hydrocarbons, and plastics. Boron and cadmium are often incorporated into the above materials or used as an additional thin layer on such materials. Boron, as boric acid, is popular as an additive to shields that use water or plastic because it is inexpensive, effective at low concentrations, and produces easily absorbed secondary radiation.

Secondary radiation, especially the conversion of neutrons to high energy gamma photons, must be recognized in the planning of the shielding for personnel. Much of the personnel exposure at neutron radiographic facilities comes from the secondary radiation rather than from the neutrons. Secondary radiation shielding uses the concrete and lead common for the more common radiographic facilities. Attention should be paid to the high energies of the secondary radiation such as capture gamma rays.

Attention should also be paid to the handling of the converter screens which can become rather radioactive in the high neutron fluxes available at nuclear reactors. The beta and other soft radiation emitted by the converter screens can easily be overlooked and can produce appreciable exposure to the hands. Finger ring dosimeters should be considered for handling radioactive screens. Appropriate dosimeters and survey instrumentation for the neutrons, the secondary radiation and the decay radiation are important and different from that used in either X-ray or gamma ray radiography.

3.0 NEUTRON SOURCES, MODERATION AND COLLIMATION

Neutrons are created in neutron sources as high energy neutrons. From the previous discussions, thermal or low energy neutrons are preferred for most neutron radiography applications. Therefore this section starts with a discussion of methods for moderation or thermalization of neutrons.

3.1 Moderation

As noted in the previous sections, neutrons are generally produced having considerable kinetic energy but are most useful for radiography as thermal or low energy neutrons. To reduce the energy of (moderate or thermalize) the neutrons, they are allowed to collide with the nuclei of atoms having low mass. In such collisions, the neutrons lose some of their kinetic energy to the nuclei. The closer the mass of the nucleus of the atom is to the mass of the neutron, the greater is the loss of kinetic energy of the neutron per collision. For example, it is possible for a high energy neutron to transfer all of its excess energy (above thermal energy) to the nucleus of a hydrogen atom (proton) in one collision. Most often more than one collision between the neutron and the nuclei in the moderator will be required even if the moderator is rich in hydrogen. Collisions of the neutron with nuclei larger than that of hydrogen transfer less energy from the neutron per collision so that multiple collisions are required to reduce the energy of the neutron to thermal equilibrium. For that reason, the best moderators for fast neutrons are the light elements. Table 3.1 lists some important properties of some common moderator materials.

Absorption of the neutron by the moderator is another important consideration in the choice of the moderator material. A light element that has a high probability for neutron absorption, such as boron, would be a poor choice as a moderator. For that reason, heavy water rather than light water is sometimes used as a moderator. See Table 3.1 for comparison of neutron cross sections of hydrogen versus deuterium (heavy hydrogen). Heavy water is far more expensive than light water.

Water is a useful moderator because of its high hydrogen content, fairly low neutron absorption and ease of use in a tank surrounding the fast neutron source (36). Other high hydrogen content, solid materials include hydrocarbons like wax, polyethylene, and other plastics. High density polyethylene is widely used in practical fixed or transportable systems. Concrete is not used as a simple moderator, but as a radiation shield.

Table 3.1 Properties of Several Moderators

<u>Material</u>	<u>Atoms/cc</u> ¹	<u>σ (barns)</u>	<u>Mod. Ratio</u> ²	<u>ξ</u> ³
Water	3.3	0.6	60	19
Heavy water	3.3	0.002	60-200	32
Beryllium	12	0.009	135	89
Graphite	8.1	0.005	175	110
Oxygen	0.003	0.003	---	150

¹ Atoms/cc X 10²²

² Moderation ratio is the ratio of the slowing down power to the macroscopic cross section.

³ ξ is the average number of collisions necessary to thermalize a given energy neutron beam.

Beryllium (metal) and graphite (a solid form of carbon) are also popular moderators for neutrons where cost is not a factor. They offer considerable dimensional stability and durability but are much more inconvenient and expensive.

The moderating material generally surrounds the neutron source as well as possible. A void channel in the moderator allows a beam of thermal neutrons to leave the assembly. The void alignment is such that a direct line-of-sight to the neutron source is not permitted; this reduces the number of fast neutrons that emerge in the neutron beam. Neutron absorbers are often placed in and around the assembly to reduce both thermal and fast neutrons from leaving the assembly and reaching the neutron radiographic location. A typical moderator-collimator arrangement with a diverging beam is shown in Figure 3.1 (55). The fast neutron source (isotope, accelerator target, etc.) is surrounded by the moderator. A filter is shown between the fast neutron source and the beam exit to help remove gamma rays. An exit channel permits neutrons that have scattered in that direction to emerge in the beam. The beam is shown as divergent, similar to a typical x-ray beam used for radiography.

3.2 Collimation

When thermal neutrons exit from a moderator, they are in random motion. Radiography requires that the paths of the radiation particles be as parallel to one another as is possible. Collimation is used to remove neutrons from the beam that are not traveling in nearly parallel paths. If fast

neutrons are being used for radiography, no collimation may be needed, assuming the source size is small, i.e., the target of an accelerator, approximating a point source. The methods that have been used for producing useful thermal neutron beams are (1) the straight wall collimator, (2) the Soller slit method (a series of small tubes to help make the beam parallel) and (3) the divergent collimator. Most neutron radiography is done with divergent collimators, as shown in Figure 3.1.

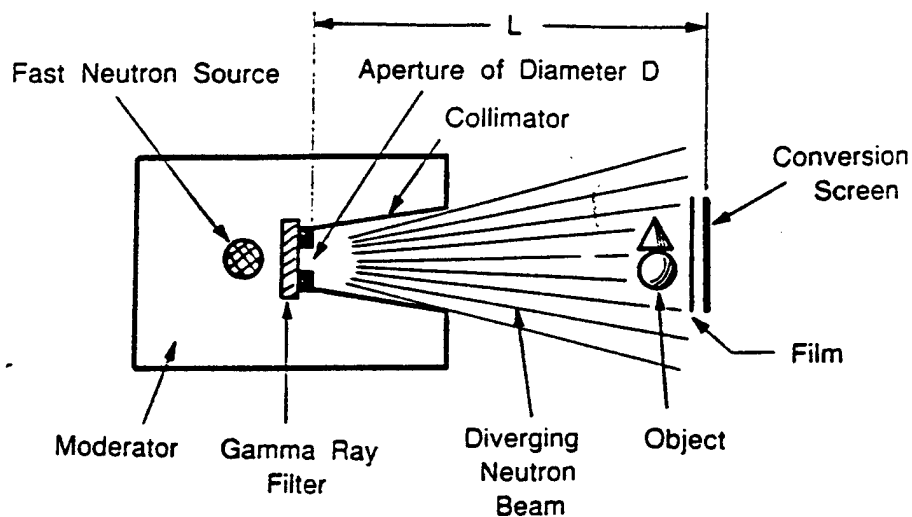

Figure 3.1. Moderator-collimator arrangement surrounding a fast neutron source. The thermal neutron beam can be characterized by the L/D ratio (55).

Also shown in the diagram are the exit aperture for the beam, D , and the distance of the aperture to the detection plane, L . The ratio of these two dimensions, L/D , is used to define the degree of collimation in the neutron beam. The higher that ratio, the better the beam will be for producing radiographs with good definition or sharpness. One can think of D somewhat as the focal spot of an x-ray tube. For example, it is not unusual to use an x-ray machine with a focal spot of 2mm to take radiographs at a source-to-film distance of 1m. This would be equivalent to a neutron beam L/D of $100\text{cm}/0.2\text{cm}$, or 500. Reactor based neutron radiography facilities typically may use a beam L/D of about 100. An isotope or accelerator source may use a beam L/D of 30. The L/D ratio is further discussed in an ASTM standard (56). The standard also describes a method to determine the value of L/D by observing the shadow of test object removed from the detection plane.

Equations that are used to calculate the effectiveness of the collimators are given below (36):

Geometric unsharpness (**U**) for relatively thin specimens close to the image plane:

$$U = T (D/L) \quad \text{Eqn. 3.1}$$

Where: **T** is specimen thickness
 D is collimator aperture diameter (circular)
 L is length of collimator or distance from aperture to the image plane

A useful approximation (36) for the beam intensity at the image plane (**I**) is as follows:

$$I = I' / [16 \{L/D\}^2] \quad \text{Eqn. 3.2}$$

Where **I'** is the beam intensity at the aperture. Recognize that collimation reduces the peak thermal neutron flux in the moderator by a factor of 10,000X in a beam L/D ratio of 25.

3.3 Nuclear Reactors

As mentioned previously, nuclear reactors are the most expensive sources of neutrons. They also produce the largest neutron fluxes. The neutron flux at the film plane may be 100 to 1000 times the neutron flux available from typical isotope or accelerator sources. This high flux, 10^7 to 10^8 n $\text{cm}^{-2}\text{s}^{-1}$, translates into improved resolution and shorter exposure times. Reactors may also yield neutron beams with a high ratio of thermal neutrons to higher energy neutrons than most other sources as well as a high ratio of thermal neutrons to gamma radiation. High thermal neutron and low gamma radiation content in the neutron beam tend to improve the quality of the neutron radiograph in most circumstances. The higher neutron flux of the reactor allows improvement in the collimation of the neutrons without excessive exposure time penalties.

Because of the high cost of the nuclear reactor, few reactor facilities are devoted to neutron radiography alone. Most neutron radiographic facilities using nuclear reactors are research reactors established for other purposes. The arrangements made at a research reactor to provide high quality thermal neutron beams for research in scattering, nuclear absorption, diffraction, etc. make the reactors useful as neutron radiography facilities. Addition of the neutron radiographic capability to the reactor rarely interferes with the original missions of the reactor facility and consumes an insignificant fraction of the neutrons available.

Most research reactors include a means for bringing a thermal neutron beam from in or around the reactor core to a point outside the reactor's biological shield. The core is the arrangement of fissionable fuel such as U-235, control rods (devices that absorb thermal neutrons which may be

moved in and out of the core volume), and a moderator. The moderator is a material such as water, heavy water, or graphite that slows fast neutrons produced by fission of the fuel into thermal neutrons that may initiate another fission. The core may be surrounded by a "reflector" that returns many of the high energy neutrons to the core. The neutron beam may be extracted from a point inside the core, outside the core, or in the reflector region. As the point of extraction for the beam is moved away from the inside of the core, the neutron flux available decreases but the ratio of thermal to higher energy neutrons increases.

Shutters to stop the neutron beam as well as gamma radiation filters (a material that has high absorption for gamma rays but low absorption for thermal neutrons such as a bismuth plug) are generally provided in or at the end of the biological shield. Neutron collimators may be placed in the biological shield or in the neutron beam after it emerges from the biological shield. Figure 3.2 illustrates an example of a research reactor neutron radiographic facility (57).

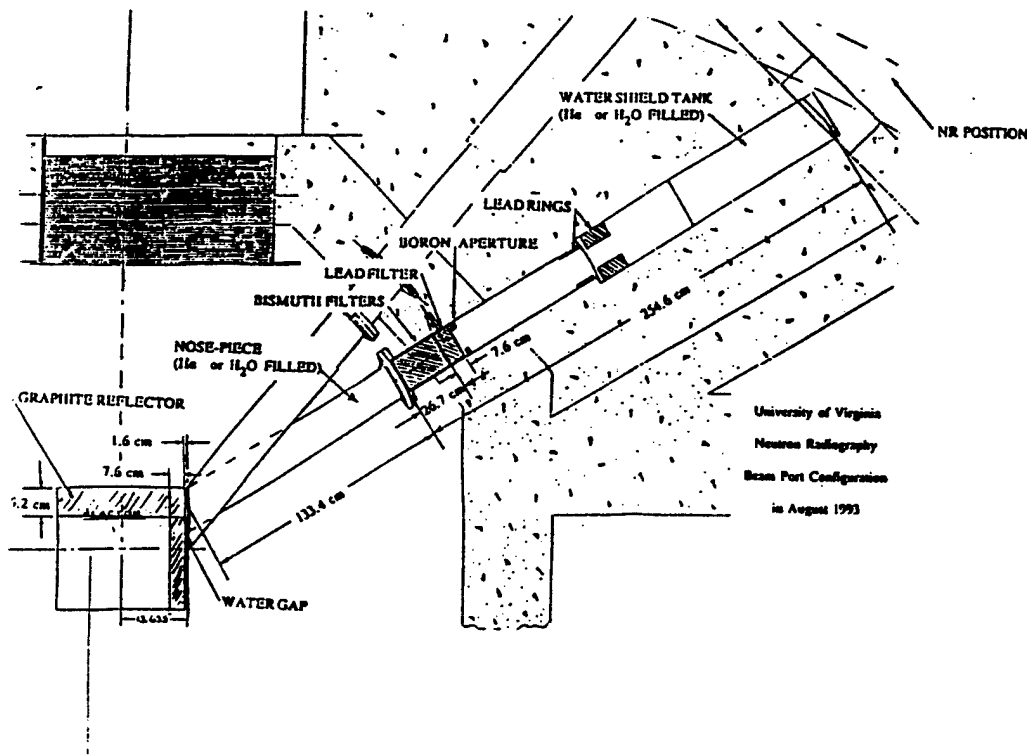

Figure 3.2 Diagram of a neutron radiographic beam at the University of Virginia reactor, showing the reactor core and reflector (lower left) and beam filters, about 1/3 the length up the beam tube (57).

3.4 Accelerator Sources

In Section 2.4, accelerator sources were described as having lower neutron outputs than reactors but having the advantages of transportability and the ability to be turned off and on with little or no radiation present when turned off. The more transportable machines offer somewhat lower neutron yields than the larger built-in-place machines. The smaller machines also make use of high yield reactions such as (d,T) which produce high energy neutrons. The high energy neutrons are more difficult to thermalize and may result in neutron beams having poor thermal to high energy neutron ratios. Such mixed neutron beams generally are not desirable for the best neutron radiographic imaging but occasionally offer some advantages.

One of the more common accelerators used for neutron production is the Cockcroft-Walton accelerator (43, 44, 45). The Cockcroft-Walton design uses a circuit in which a set of capacitors are charged in parallel during one half of an alternating current cycle. During the second half of the alternating current cycle, the set of capacitors are switched from parallel to a series connection to achieve an accelerating voltage that is a multiple of the alternating current charging voltage. Accelerating voltages of 100 to 400 keV are often produced in this fashion and are sufficient to produce neutrons by either the (d,D) or (d,T) reactions. Figure 3.3 is a photograph of a transportable Cockcroft-Walton type of accelerator, shown in the process of a field inspection (44, 58).

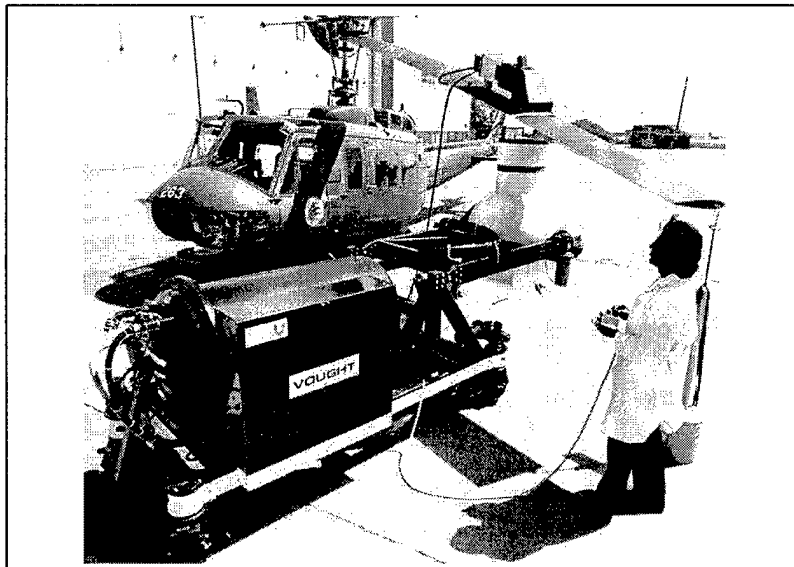

Figure 3.3 Photograph of a transportable (d,T) neutron source shown set up to radiosopic inspection of a helicopter blade. The round object below the blade houses the accelerator target, moderator and collimator (44).

The (d,D) reaction produces neutrons with an energy of about 2.5 MeV at low accelerating voltages. At high accelerating voltages, some of the additional accelerating energy increases the resultant neutron energy. Neutron yield also increases for the (d,D) reaction as the accelerating voltage is increased. The (d,T) reaction produces 14.3 MeV neutrons at the threshold accelerating voltage of about 120 keV. Increases in the accelerating voltage only increase the neutron yield slightly (mostly a function of the tritium target thickness and material) and the neutron yield decreases with increases in

accelerating voltage above about 500 keV. While the neutron yield from the (d,T) reaction is 60 times that of the (d,D) reaction, thermal neutron flux fails to increase by the same factor because the 14 MeV neutrons are so much more difficult to thermalize. Another disadvantage to the (d,T) reaction is that the neutron yield decreases with target use time because the tritium is being depleted both by the nuclear reaction and by heating of the target. The heating of the target releases quantities of the tritium (radioactive hydrogen) into the vacuum system and finally into the atmosphere in pumped, non-sealed systems. Most modern (d,T) neutron sources make use of sealed tubes, which eliminate many of the tritium handling problems. Life-times of sealed (d,T) neutron tubes approach 4,000 hours before the neutron yield is reduced to half that at maximum neutron yield (58, 59).

Small Van de Graaff accelerators have been used for neutron radiography (24, 49, 60, 61). The accelerating potential in a Van de Graaff accelerator is produced by placing an electrical charge on a moving, non-conductor belt, removing the charge from the belt at a distance from the charging point, and storing the charge on a smooth, almost spherical metal surface. Extremely high voltages can be created in this fashion which permits a variety of other nuclear reactions to be used to produce neutrons. A diagram of a Van de Graaff accelerator is shown in Figure 3.4. Some examples of neutron producing nuclear reactions used in Van de Graaff accelerators are the acceleration of protons or deuterons into beryllium, protons into lithium-7, deuterons into carbon-12, and deuterons into either deuterium or tritium targets. Most of the Van de Graaff accelerators used for neutron radiography are large systems set up for other purposes such as research in nuclear physics.

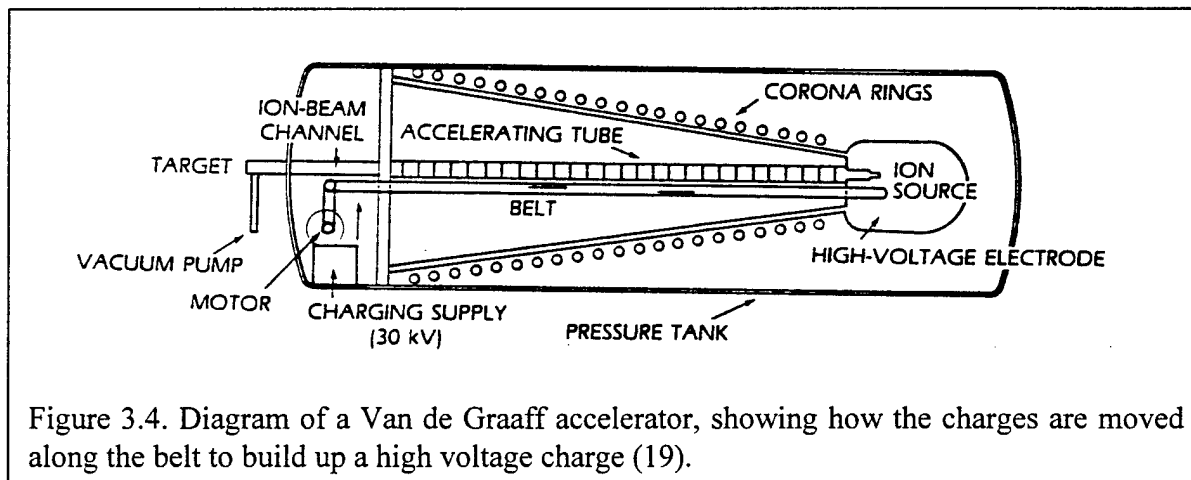

Figure 3.4. Diagram of a Van de Graaff accelerator, showing how the charges are moved along the belt to build up a high voltage charge (19).

Linear accelerators are also useful sources for neutron radiography. Some early work was done with a LINAC x-ray source, the high energy x-rays being used to produce neutrons from an (x,n) reaction in a beryllium target (62). An x-ray intensity of 650 R/minute at 1 meter resulted in a thermal neutron beam of $5 \times 10^4 \text{ n cm}^{-2} \text{ s}^{-1}$, with fair collimation. The x-ray method for producing neutrons may be important for inspection facilities that have a high energy x-ray source and need neutron radiographic capability only rarely. Nevertheless, the intense x-ray background makes neutron radiography difficult.

New accelerators, using radio frequency quadrupole techniques are now available (28, 30, 63), offering a range of neutron outputs, up to neutron radiographic beam intensities in the order of $10^6 \text{ n/cm}^2\text{-s}$ with excellent collimation (L/D values of 100). These accelerators typically use a neutron reaction of protons or deuterons on a beryllium target to produce fast neutrons of a few MeV in energy. Recent work has shown that these long, high output accelerators might be adapted as transportable neutron radiography sources, as shown in Figure 3.5 (63).

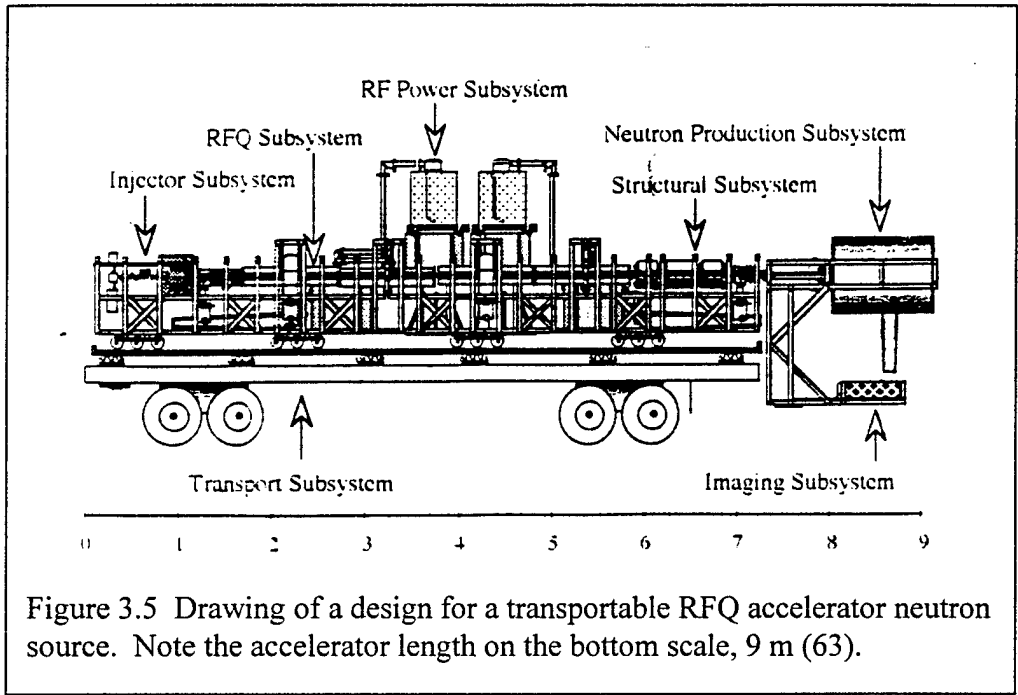

Figure 3.5 Drawing of a design for a transportable RFQ accelerator neutron source. Note the accelerator length on the bottom scale, 9 m (63).

Cyclotrons also have been used for neutron radiography. Compact units can produce high neutron yields into moderator-collimator assemblies, for intense thermal neutron radiography beams (47, 64, 65). A cryogenically cooled cyclotron, accelerating 12 MeV protons on a beryllium target, has been used for thermal neutron radiography, with beam intensities of $7.3 \times 10^5 \text{ n cm}^{-2}\text{s}^{-1}$ at an L/D of 100 (28, 47). A conceptual drawing of such a cyclotron neutron radiography source as a transportable system is shown in Figure 3.6 (65).

New high voltage machines sources accelerating high energy protons can produce intense neutron yields by the spallation process. A large, expensive machine (590 MeV) designed for nuclear research is now being used for neutron radiography, as indicated earlier in Section 2.4 (48).

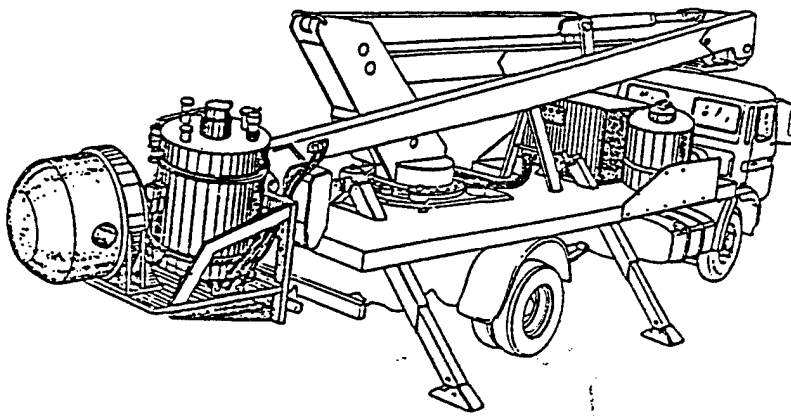

Figure 3.6 Artist drawing of a transportable cyclotron neutron radiography source (65).

3.5 Radioisotope Neutron Sources

No radioisotope of the 92 elements occurring in nature emits neutrons. Neutron emission is produced by combining radioisotope sources with target materials or by making a transuranic radioisotope like Californium-252 which decays by spontaneous fission. The more common radioisotope neutron sources are combinations of alpha emitting radioisotopes such as Polonium-210, Americium-241, or Plutonium-239 with beryllium. The alpha particle interacts with the beryllium to release a neutron while forming an atom of carbon-12. The combination of the radioisotope and beryllium must be very well mixed very fine powders of each material because of the short range of the alpha particle. Preparation of mixtures of such fine powders of two toxic substances must be carried out with great care. The mixture is placed in stainless steel capsules that are welded closed. In some cases, the radioactive mixture is double encapsulated. The resultant source is typically a right circular cylinder about 1 inch in diameter and 1 inch tall. Each of the alpha emitting radioisotopes listed above will produce about 2×10^6 n/sec per curie of activity when mixed with beryllium.

The Californium-252 neutron source spontaneously fissions and therefore does not have to be mixed with a target material, such as beryllium. A stainless steel encapsulated Cf-252 source emitting 10^9 n/sec would only contain 1 milligram of the radioisotope and would be about 1.27 cm in diameter and 3.81 cm long (0.5 X 1.5 in.) Size of the capsule is convenient for fabrication, durability, and handling and changes little for much larger quantities of the radioactive material. The Cf-252 is made by multiple successive neutron captures in Uranium-238 in very high neutron flux nuclear reactors. The Cf-252 is removed by chemical separation from the mixtures of materials formed. Even with such an expensive production

technique, cost of the Cf-252 has been in the range of \$10 to \$20 per microgram (2.3×10^6 n/sec per microgram.) However, encapsulation and transportation charges can vastly overshadow the isotope cost.

Radioisotope neutron sources would be far too bulky and expensive for use as sources for quality neutron radiography which normally requires approximately 10^{10} fast n/sec for reasonable thermal beam intensities. The radioisotope sources can produce neutron radiographs in circumstances where portability and lack of external power are important and radiographic quality need not be the best.

3.6 Sub-critical Assemblies

Sub-critical assemblies combine the production of neutrons by a fast source such as Cf-252 with some neutron multiplication by U-235 fission such as exists in a nuclear reactor. The multiplication is kept below what is necessary for a self-sustaining fission reaction. These assemblies increase the neutron yield from a given source by factors as high as 30 but lose the portability of the radioisotope source and become fixed in place sources. The sub-critical assemblies do not require the safety features and additional licensing and personnel required by a reactor but they also do not provide the high neutron output available from a reactor. As indicated in Section 2.4, a fixed sub-critical neutron source was used extensively for radiography at the Mound Laboratory in Ohio, until closed down in the early 1990's (51,52). Development that placed fissionable materials within the moderator assembly of an accelerator source has also been reported (67), the end result being an increase in the available neutrons by a factor of 1.5.

4.0 NEUTRON IMAGING TECHNIQUES

4.1 Indirect or Transfer Imaging Techniques

In Section 2.5, the process of indirect or transfer neutron radiography was very briefly described. This technique provides some of the more unusual advantages of neutron radiography such as radiography of highly radioactive specimens. The technique also permits discrimination of the type of radiation being imaged; i.e., neutrons versus gamma radiation or one energy range of neutrons versus other energy ranges of neutrons.

Indirect or transfer neutron radiography is performed by exposing an imaging screen to the neutrons transmitted through the specimen without film being present. These imaging screens become radioactive by interaction with the neutrons; a radioactive "image" is formed on the screen by the neutrons transmitted through the specimen. When sufficient radioactivity has been induced in the screen, exposure to the neutrons is ended and the screen is transferred to a cassette containing film (done in a non-radiation area). See Figure 2.1. The radioactivity in the screen is allowed to decay for a period of time sufficient to expose the film. Good contact between the screen and the film is essential for good quality image production. Major exposure to the film is by beta particles from the decaying radioisotope in the screen. In a few instances, the radiation emitted may be weak gamma radiation from isomeric transitions or x-rays which follow electron capture. Table 2.2 includes a listing of screens used for the indirect or transfer technique.

Production of the radioactive species in the screen (sometimes referred to as 'foil' since they are usually very thin metal sheets) can be described by the equation:

$$A = N \sigma \phi [1 - e^{-0.693t/T}] \quad (\text{Eqn. 4.1})$$

in which

- A** is the activity produced in disintegrating atoms/second
- N** is the number of target atoms per cc in the specimen
- σ** is the cross section of the target atom in cm^2 .
- ϕ** is the neutron flux in $\text{n cm}^{-2} \text{sec}^{-1}$.
- t** is the neutron exposure time
- T** is the half life of the isotope produced.

At the moment that neutron exposure is discontinued, the radioactive isotopes in the screen decay according to:

$$A = A_0 e^{-0.693t/T} \quad (\text{Eqn. 4.2})$$

in which

- A is the activity remaining after decay time t or the time from end of activation to measurement.
- A_0 is the activity at the end of neutron exposure.
- t is the time of decay after the end of the neutron activation.
- T is the half life of the isotope.

Notice should be taken that the quality of the image on the screen will be a function of the usual radiographic parameters such as source size, source-to-film distance, thickness of the specimen, closeness of the specimen to the detector as well as other geometric factors, scatter of the radiation in the specimen and around the screen plus neutron absorption characteristics of the specimen versus its flaws and the statistics of radiation decay and detection. Section 2 contains information on the factors affecting neutron absorption in the specimen (especially cross section). Information on the details of radioactive decay and detection statistics can be found in nuclear science or nuclear engineering books (39, 40, 67). It is sufficient here, to note that the quality of the image obtained from the screen will be dependent upon the amount of the radioisotope produced in the screen. Better images are obtained by producing more radioactivity in the screen.

Equation 4.1 then predicts that exposure or activation time improves the quality of the image only initially. After several half lives in exposure or activation time, the radioactivity in the screen reaches saturation (no longer increases) and longer neutron exposure does not improve image quality. For example, a period of 3 half-lives produces 87.5% of the possible activation or autoradiographic exposure that can be obtained. Improvements in the image quality must then come from larger neutron fluxes or use of screens having target atoms with a greater cross section for neutron reaction. Typical screen materials used for the transfer method include indium (54.1 minute half-life) and dysprosium (140 minute half-life).

Note that in the same fashion, exposures of the screens to film longer than a few half lives do not materially improve the image quality because there is little radioactive decay of the desired radioisotope remaining. Also note that using thicker screens to increase the number of target atoms reduces image quality from geometric and scatter factors and may result in some absorption of the radioactive emission within the screen. Screen thicknesses of about 0.010 inch for indium and 0.005 inch for dysprosium are close to the saturation limit in terms of film density (12). If high neutron flux is not available, the choice is then usually to change from indirect imaging to direct imaging or to another technique such as track-etch imaging.

Track-etch techniques produce insulating material films with damage tracks that can be chemically etched to disclose an image (68). Typical materials for thermal neutron radiography include an alpha emitter, such as lithium or boron, used with a cellulose nitrate film. The alpha particles produced upon neutron absorption damage the plastic. A chemical etch, typically 30 minutes in a potassium or sodium hydroxide solution, reveals the pattern of small etch holes (69). The image can be observed or photographed by a side-light method. There are many advantages

of track-etch: (1) easy handling of films in the light, (2) response to thermal neutrons and not to gamma rays, (3) linear response over several orders of magnitude of exposure, (4) excellent resolution because of the short range of the alpha particle and (5) exposure as long as needed for a useful image. For the application to neutron radiography of radioactive materials (69), track-etch methods eliminate exposure problems that might result from low neutron flux, as is true for the transfer film method. Exposures can be as long as necessary. Exposures in the order of 10^9 n/cm² are usually used for track-etch thermal neutron images.

4.2 Direct Neutron Imaging

Direct neutron imaging describes the simultaneous use of a neutron converter screen and film in the neutron beam (see Figure 2.1.) The screen is necessary to convert the neutrons into a more detectable radiation to expose the film. In this case, longer exposure times should materially improve the radiographic image on the film. The radiation detected by the film is most usually prompt radiation or radiation that is released by the target atom immediately after neutron interaction rather than being released by the decay of a radioactive species. In fact, the neutron interaction need not produce a radioactive product so long as the neutron reaction involves release of some radiation detectable by the film.

Since decay of a radioactive species is not usually a strong contribution to the image production, the radiation contributing to the image is represented by:

$$E = N \sigma \phi t \quad \text{Eqn. 4.3}$$

in which

E is the number of interactions producing exposure of film.

N is the number of target atoms.

σ is the cross section of the target atoms.

φ is the flux (n cm⁻² sec⁻¹).

t is the neutron exposure time in seconds.

The conversion screen most used for direct thermal neutron radiography is gadolinium, a very high cross section material (see Table 2.2). Since thermal neutron absorption is so high in this material, it is feasible to use a very thin screen, 0.001 inch or less. For optimum results a single conversion screen is used in back of the film. The neutron reaction with this material produces an internal conversion electron, of energy about 70 keV, radiation that is easily detected by an x-ray film. The high detection efficiency and the short range of the emitted electron result in neutron radiographs of excellent quality. Spatial resolution values of 10 microns have been reported (70). Fine grain, single emulsion films are often used with a gadolinium screen to produce high quality thermal neutron radiographs; exposure needed is in the order of 10^9 n cm⁻². Faster film results can be obtained by using faster films with a single or multiple gadolinium screens or by light-emitting screens with a fast light-sensitive film. A Li⁶F-ZnS scintillator with

a fast film can provide useful results with much faster exposures, in the range of $10^5 \text{ n cm}^{-2} \text{ s}^{-1}$.

A summary of the characteristics of film exposures, both direct and transfer types may be useful. The transfer films have the advantage of having no response to gamma radiation, an advantage that often results in improved contrast. Exposures tend to be longer than direct exposures because two exposures are needed. Spatial resolution is good, in the range of 50 microns, but not quite as good as can be achieved with the direct method using a gadolinium screen. Direct film methods can be obtained with only one exposure, so an image can usually be viewed in less time. Also, as noted, direct exposures with a single gadolinium screen can yield neutron radiographs that display detail as small as 10 microns. Track-etch methods offer insensitivity to gamma radiation, good resolution, wide dynamic range and exposures as long as needed for a useful image.

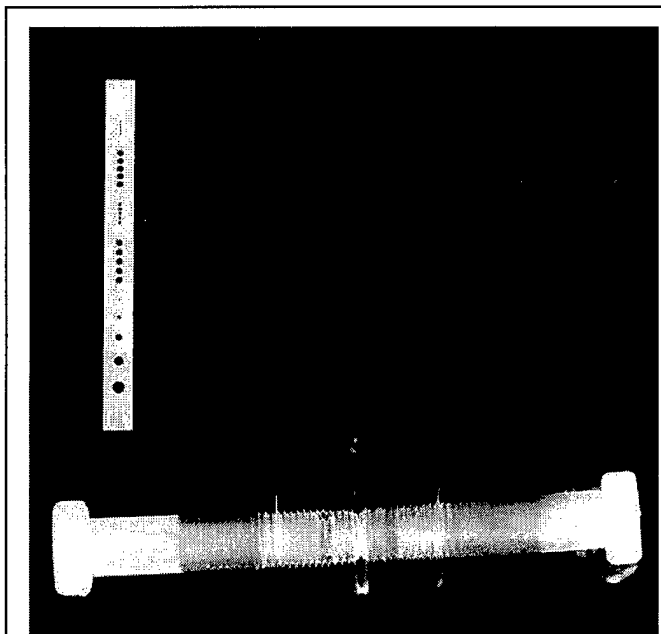

Figure 4.1 Direct thermal neutron radiograph taken with a gadolinium screen showing a cracked double cantilever beam aluminum sample. Hydrogen deposits along the vertical crack above the location where the screws meet is evident. The cadmium test bar at the left shows images of many small holes, including the sequence at the top, 0.25mm holes spaced 0.25mm apart (71).

Examples of the three types of images are shown in Figures 4.1, 4.2 and 4.3. Figure 4.1 is a direct thermal neutron radiograph of a cracked aluminum, acid-treated double cantilever beam sample. The radiograph shows evidence of hydrogen along the vertical crack just above the location where the screws meet. Also shown is the vertical image of a cadmium test piece with sets of holes. The smallest hole is 0.25mm diameter. The sets of holes at the upper part of the test piece are 0.25mm holes separated by 0.25mm, a true representation of 0.25mm resolution (71). Figure 4.2 is a transfer neutron radiograph taken with dysprosium and a medium speed x-ray film. The image shows a portion of an irradiated, highly radioactive nuclear fuel sample; cladding rupture and voids in some fuel specimens is indicated, along with deposits of fuel material in the bottom of the tantalum cup (72). Figure 4.3 is a track-etch image of radioactive, irradiated nuclear fuel, taken at the French nuclear center at Saclay (69), where track-etch neutron radiography is routinely done. The positive image shows severe cracking in the fuel pellets.

Figure 4.2. A transfer thermal neutron radiograph of irradiated nuclear fuel shows cladding rupture and fuel deposits in the bottom. Image taken with an indium transfer screen (72).

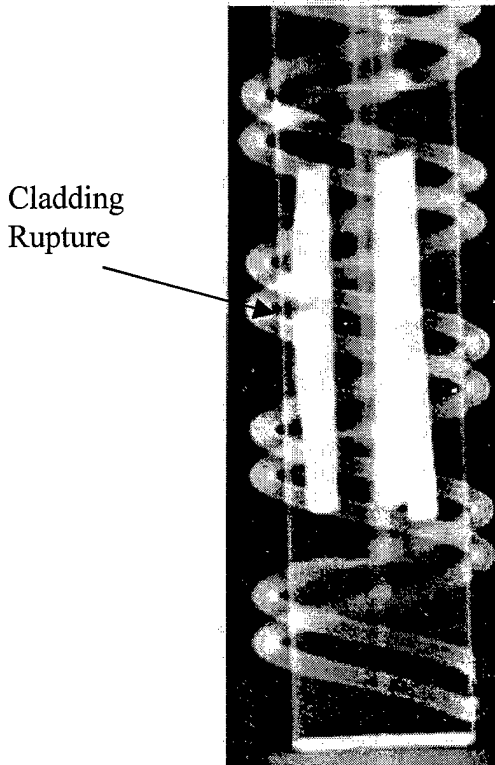

Figure 4.3 A track-etch neutron radiograph of nuclear fuel, showing extensive cracking (69).

4.3 Radioscopy (Real Time Imaging)

Neutron radioscopy systems can provide real-time images while the neutron exposure is occurring. The systems may incorporate a neutron conversion screen in an image intensifier tube. Screens of LiF-ZnS and gadolinium oxysulfide have been used in neutron image intensifier tubes. In addition, as discussed briefly in Section 2.5, these light-emitting screens may be used with a mirror-lens-camera system (28, 29, 30, 47, 48, 57, 73), as shown in Figure 2.2. Boron nitride scintillators have also been investigated for both film and camera imaging but thus far have seen little application (74, 75). Other solid state camera systems, GaAs arrays, for example, have also been investigated for neutron radioscopy imaging (76). These systems may provide very fast imaging with high neutron flux sources so that motion of the specimen can be observed.

For good image quality, one seeks to have a neutron exposure per image of about 10^5 n cm^{-2} . For a typical television system showing images at the rate of 30 frames/s, this means that a neutron source that supplies a beam intensity of $3 \times 10^6 \text{ n cm}^{-2} \text{ s}^{-1}$ will provide good quality, real-time images. Useful neutron radioscopic images can be obtained with lower neutron beam intensities, but one may have to use a slow scan technique, say 5 or 10 frames/s, or make use of images with more noise. Recognize that an exposure of $10^5 \text{ n cm}^{-2} \text{ s}^{-1}$ will result in images with some quantum noise, that is noise due to fluctuations in the neutron beam itself (28, 70).

A diagram of a typical screen-CCD camera system was shown in Figure 2.2. Neutron image intensifier tubes are commercially available, with a 9-inch diameter input screen. Neutron radioscopic methods have been used in high through-put inspection of aircraft to detect corrosion (28, 29) and to image dynamic events to investigate object movements during a process. For example, a reactor pulse has been used to perform fast neutron imaging of explosive firing and to observe two-phase flow, at frame rates up to 10,000 frames/s (77). At more conventional, 30 frames/s rates, dynamic neutron imaging has been used to follow movement of fluids in engines and transmissions (78, 79), to observe coking in engine nozzles (80, 81) and to observe movement of moisture (82). An example of a dynamic thermal neutron image sequence is shown in Figure 4.4 (total time from image 1 to the end is 0.66 seconds). Image 1 shows the start of a pour of Wood's metal into an aluminum mold. It can be seen in frames 6 and 7 that the vertical riser of the mold begins to fill before the vertical leg of the casting below. This poor casting design will lead to porosity in the casting (34).

The applications cited provide evidence for the usefulness of neutron radioscopic methods.

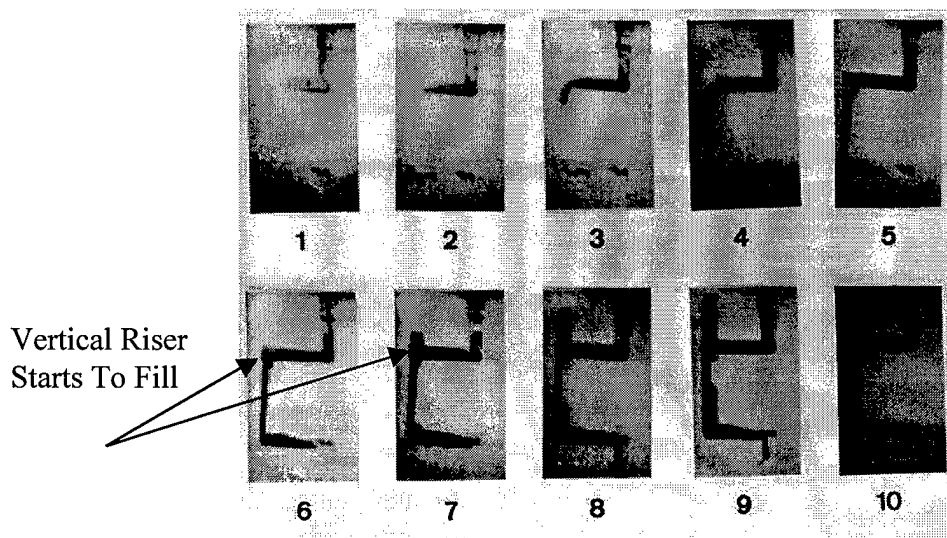

Figure 4.4. A dynamic thermal neutron sequence showing the pouring of Wood's metal into an aluminum mold. The time for the entire sequence was 0.66 seconds (34).

4.4 Neutron Computed Tomography

Just as X-ray and gamma ray radiography have found use in computed tomography (CT) applications (83), neutron tomography has been used to provide important information. The ASTM standard cited (83) is a CT tutorial document that includes a glossary of terms and an extended list of references. The image produced in a conventional radiograph is a shadow image of the specimen's density and thickness, whereas a tomographic image is a cross sectional image (a slice) of the specimen parallel to the radiation beam. In addition, this slice is essentially free from features in other object slices or planes, unlike a conventional radiograph which shows a superposition of all planes in the image. CT can be accomplished by passing a thin, wide beam (often called a "fan" beam because of its shape) of radiation through the slice of the specimen to be imaged, or in more recent developments, using conventional cone beam techniques. The radiation is detected by a line or row of detectors, or by an area imager, on the opposite side of the specimen. For the fan beam approach, the specimen, or the source-detector assembly, is rotated so that the specimen is examined with the radiation beam passing through all segments of the specimen (usually 180 degrees of rotation.) In some cases, the specimen may be moved laterally through the beam between rotations. In the case of the cone beam method, the object can be rotated in the beam to collect the required number of views. A computer then reconstructs a cross sectional image of the specimen from the thousands of individual absorption measurements made through the specimen.

Neutron CT imaging has been applied to a wide range of applications including nuclear fuel (84), aircraft components, material testing and archeology applications (85, 86, 87).

4.5 Other Neutron Imaging Techniques

Image detection methods for neutrons other than thermal are available. Cold neutrons and near epithermal neutrons can be detected by methods similar to those described for thermal neutrons. In addition, there are materials which exhibit resonances at selected neutron energies that can be used to detect neutrons in the near epithermal energy range. For example, indium exhibits a large activation resonance at an energy of 1.46 eV. This transfer image method has been used for neutron radiography of nuclear fuel to obtain improved transmission of these higher-than-thermal energy neutrons. An example is shown in Figure 4.5. The transfer neutron radiographs of irradiated fuel were taken with thermal neutrons for the view on the left. The high neutron absorption of the enriched fuel results in sharp edges which are useful for dimensional measurements. The resonance neutron radiograph on the right, taken by filtering the beam through cadmium to remove thermal neutrons before the neutrons strike the indium screen, shows much improved transmission through the fuel so internal details can be seen (70).

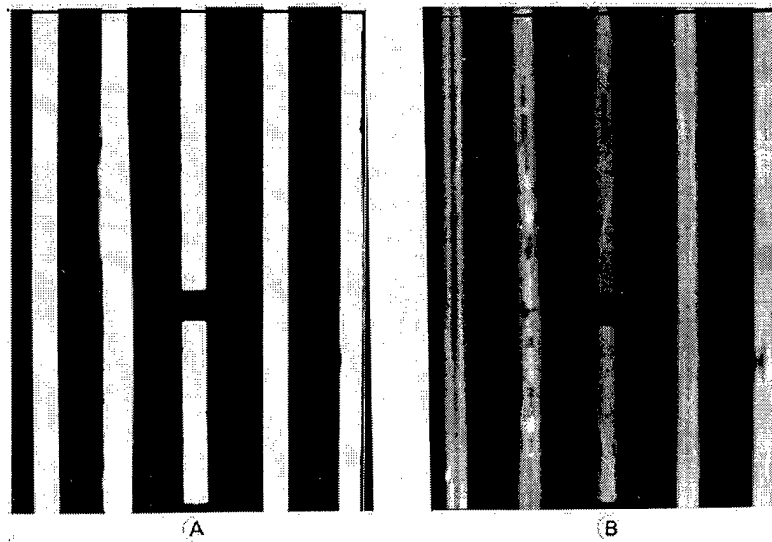

Figure 4.5. Transfer neutron radiographs of irradiated, enriched nuclear fuel. The view at the left was taken with thermal neutrons for dimensional measurements. The view at the right, taken with a cadmium-filtered indium screen technique, shows improved penetration of the fuel to observe internal cracking and deposits (70).

Radiography with fast neutrons has also been investigated (88, 89, 90, 91). Image detection usually depends on knock-on protons from a hydrogenous material stimulating adjacent phosphor grains. The hydrogenous binder combined in a typical phosphor screen used for x-ray imaging will provide fast neutron radiographs with film. Once a scintillator is available to emit light when irradiated with fast neutrons, then a radiosopic image method can also be used (90, 91). Fast neutron imaging can also be done using the indirect methods of activation transfer and track-etch (70).

There are other methods for imaging of neutrons that should be mentioned (70). Thermoluminescent phosphors, such as LiF can be used for neutron imaging by irradiating the phosphor and then capturing the emitted light as the phosphor is heated. A spark counter technique has been used to image neutrons, using an array of wires and a boron screen. Neutron capture in the boron causes release of an alpha particle, which ionizes the gas in the spark counter enclosure, causing a spark. A collection of spark images will produce an overall image of the incident neutron beam. Ionography, a method of making an electrostatic image on an insulating surface by ionization caused by the radiation, has been investigated for x-ray (92) and neutron imaging (93). These alternate neutron imaging methods have not been widely used.

However, a new radiation imaging method, making use of a photostimulable luminescent (PSL) phosphor is likely to become important for both x-ray and neutron imaging. The PSL phosphor, typically a europium activated barium fluorohalide, can be coated on a rigid or flexible substrate (94, 95, 96). Storage phosphors have been studied extensively for x-ray imaging. The phosphors emit light that has been trapped upon radiation exposure when the phosphor image plate is irradiated with a long wavelength light, such as that from a red laser. The emitted light is collected by a photomultiplier tube, whose output is correlated with the position of the laser spot to form an image. After the image is read out and displayed, the remaining signal on the image plate is erased by exposure to white light and/or infrared. The storage phosphor process is illustrated in Figure 4.6. Storage phosphors offer sensitive, wide dynamic range, digital imaging with re-usable image plates. In addition, no image processing chemicals are required, an advantage in terms of environmental problems.

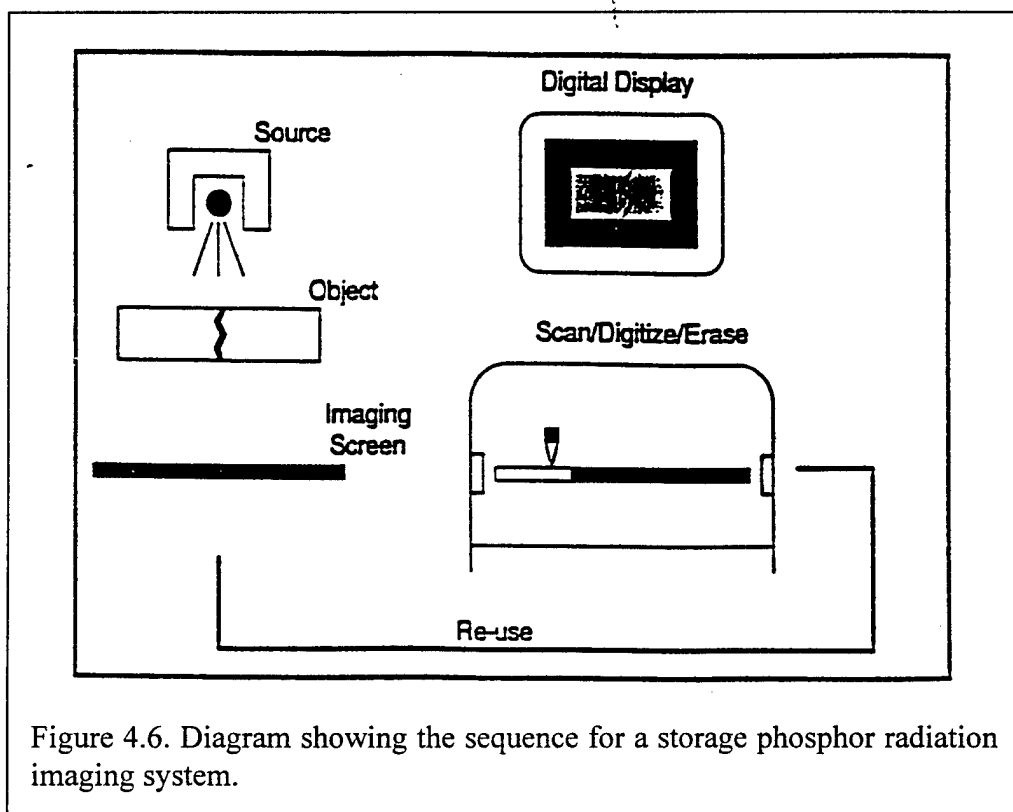

Figure 4.6. Diagram showing the sequence for a storage phosphor radiation imaging system.

Thermal neutron imaging has been done with these new image plates by adding conversion screens as is done with film. Work is reported with gadolinium, lithium-6 or gadolinium oxysulfide converters (97, 98, 99). Storage phosphor techniques offer similar advantages for neutron imaging as has been found for x-ray imaging.

4.6 Contrast Agents

If the specimen does not possess components that respond to neutron imaging, some components such as cracks, channels, or voids may be filled with substances that possess large neutron attenuation cross sections. As an example, water containing boron compounds such as boric acid or borax may be allowed to infiltrate the features of interest. Contrast agents may be added to the components to be imaged; i.e., boron, lithium, helium or rare earth compounds may be added to the inspection system or in the manufacture of materials such as bonding agents, "O" rings, insulators, or metallic parts so that they can be more readily imaged. The contrast agent may be needed to utilize a lower neutron flux or to reduce exposure times, as well as to increase sensitivity of detection. Some references describing studies with neutron contrast materials are cited (100, 101, 102). The neutron radiographic examination of turbine blades, using gadolinium material contrast agents is a widely used example for enhanced imaging by contrast agents (103, 104), as shown in Figure 4.7 (34).

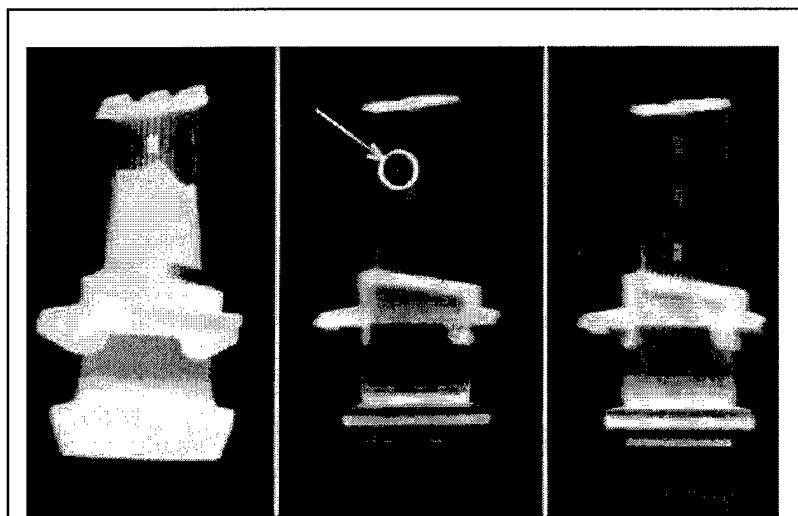

Figure 4.7. Thermal neutron radiograph of investment turbine blades showing evidence of residual ceramic core after leaching. Gadolinia is added to the ceramic core material or a gadolinia wash is used after leaching to increase detection sensitivity (see references 103 and 104).

In a few circumstances, the energy of the neutrons may be changed to increase the relative absorption by components of a specimen. Many elements exhibit very large resonance absorption cross sections for neutrons in the epithermal range. By using neutron fluxes that are high in epithermal neutrons, elements and the components that contain them may be better imaged than by thermal neutron fluxes alone. Resonance absorption elements then become contrast agents for the components in which they are found, if neutron energy of the beams can be modified. In addition, as discussed earlier, epithermal neutrons may show

increased penetration of materials or isotopes that strongly absorb thermal neutrons; see Figure 4.5 for an example.

5.0 STANDARDS/RECOMMENDED PRACTICES

5.1 SYSTEM PERFORMANCE

Important parameters of a neutron imaging system include the neutron energy spectra, the relative intensity and energy of other radiation (mainly gamma radiation and scattered radiation in the imaging beam), and the geometric properties of the system. There are standards which address these variables.

Four standards for neutron radiography are available from the American Society for Testing and Materials (ASTM). Standard E 748 (55) is a tutorial document that describes the general method and provides guidance. Methods for measurement of dimensions of objects in a neutron radiograph are described in Standard E 1496 (105). Image quality measurements for thermal neutron radiographs are described in Standard E 545 (106). This approach makes use of test pieces whose images on a neutron radiograph can be analyzed to determine a measure of image quality. Standard E 803 (56) describes a test piece and method for measurement of the L/D ratio in neutron radiographic beams (see Figure 3.1). The L/D ratio is a determining factor in the sharpness of an image in a neutron radiograph.

Figure 5.1 is a diagram of an image quality measurement test object, called a beam purity indicator (BPI) in ASTM E 545 (106). The main frame of the test piece is made of polytetrafluoroethylene, a material reasonably transparent to thermal neutrons. There are four holes in the corners; these contain filters of boron nitride (BN), to attenuate thermal neutrons, and lead, to attenuate gamma or X-rays. Film density measurements are taken in several places within the BPI image on the resultant thermal neutron radiograph. Ratios of these film densities provide a means to calculate several important parameters, including effective thermal neutron content, effective scattered neutron content, effective gamma content and effective pair production content. For example, the effective thermal neutron content involves the total film density, taken in the region of the large central hole, less the film density under the BN filter, plus the difference in film density under the two lead filters, divided by the total film density. Normally the effective thermal neutron content as determined in this way is in the 45%-65% range. Similarly, there are formulas for calculating the other variables as imaged on the thermal neutron radiograph by the BPI. These measurements provide a method for comparing radiographs taken at different times or under different conditions. The measurements are influenced by the characteristics of the neutron radiographic facility as determined by the object and set-up for the particular radiograph being measured. The measurements, therefore, relate to the neutron radiograph.

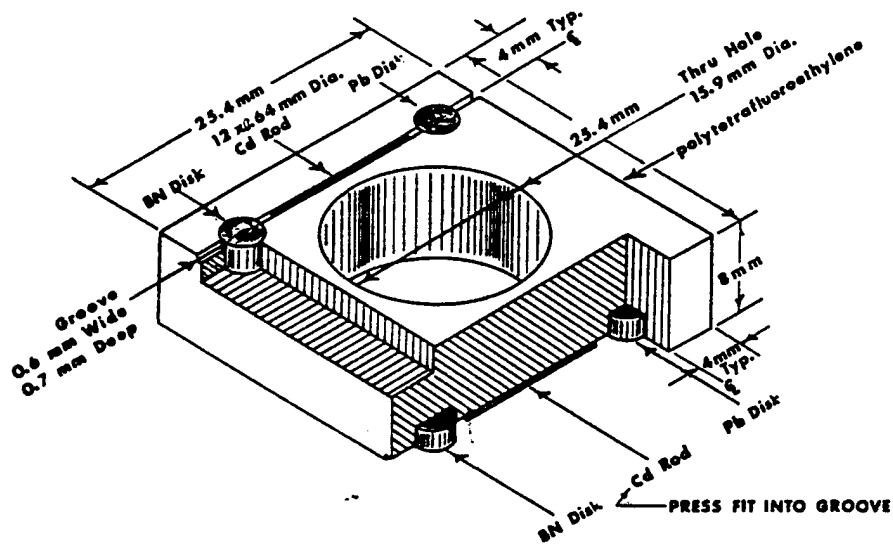

Polytetrafluoroethylene
 Cadmium 99.999 % pure
 Lead 99.999 % pure
 BN-Boron nitride
 UCAR Grade HBN

NOTE—Pb and BN disks are 4 mm in diameter and 2 mm thick.

Figure 5-1. Beam purity indicator (BPI) test piece as described in ASTM E 545, 1998. (From ASTM E 545, reference 106.) Reprinted with permission.

A second image quality indicator described in ASTM E 545 (106) is shown in Figure 5.2. This sensitivity gage provides an important measure of spatial resolution by means of gaps formed by varying the thickness of aluminum spacers between plastic supports. This relates closely to neutron radiographic applications in which measurements involve gaps, as in some small explosive devices, for example. Images of the holes in plastic shims A, B, and C give a measure of radiographic contrast and resolution by means of images of small holes as differing percentages of material thickness penetrated. Shim D, under a lead filter, provides a visual measure of the relative neutron-to-gamma properties of the beam for the radiograph since an image of the lead shim indicates some detectable X-ray or gamma ray component in the beam.

All measurements relating to ASTM E 545 (106) were developed for direct exposure neutron radiographs with single emulsion film and a single gadolinium conversion screen. It is recognized in the standard that measurements for other neutron radiographic detection systems may not relate well. There are efforts in ASTM to rewrite E 545 in order to produce one document that describes how to perform the measurements (as presently in E 545) and another document to describe how to fabricate the image quality indicators. These changes, should they take place, are not expected to result in any significant changes in the present concept of the standard.

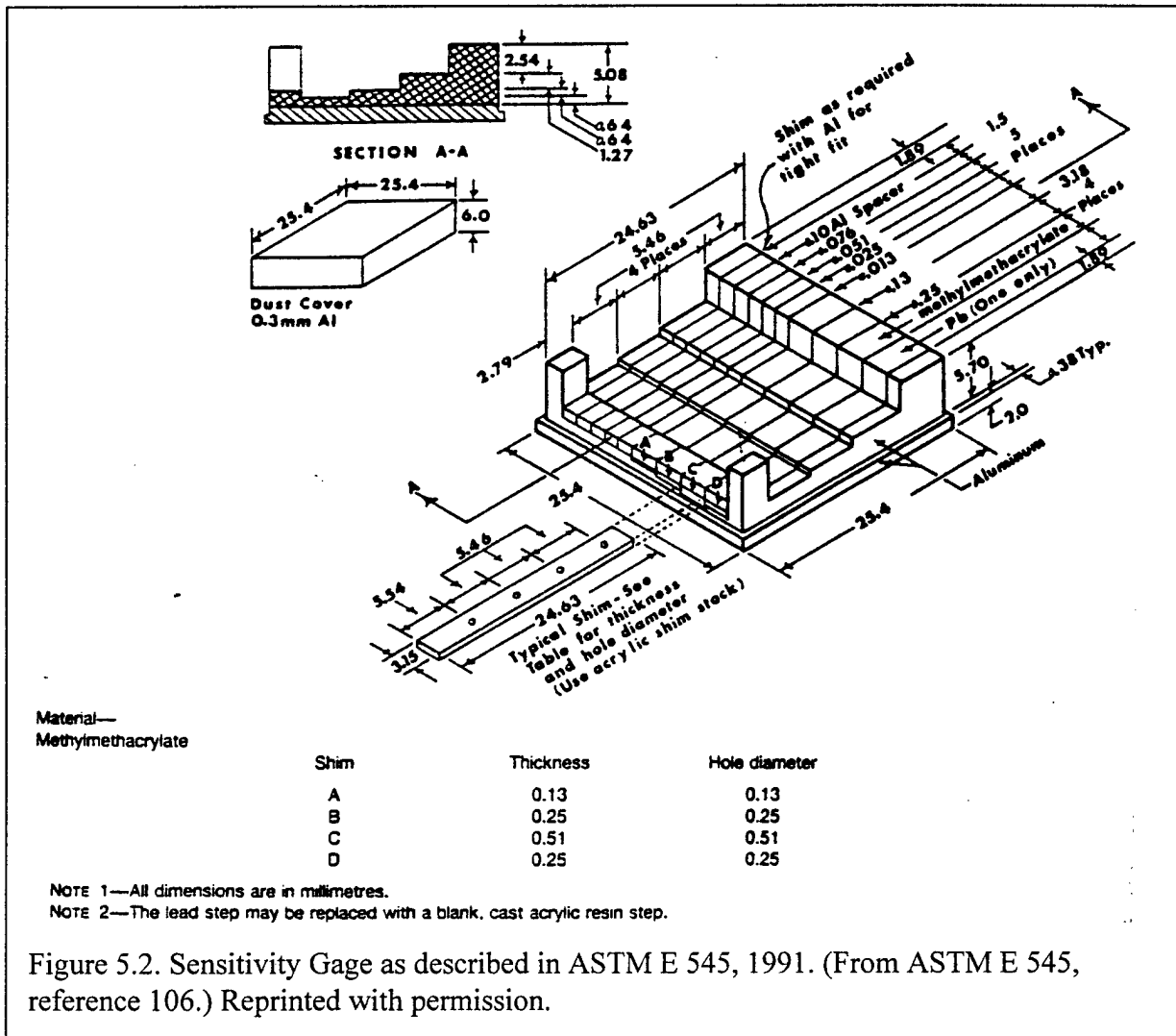

The geometry of the imaging beam, particularly in terms of the unsharpness related to the image of an object somewhat removed from the detector, is discussed in a third ASTM standard, E 803 (56). Geometric unsharpness for X-radiography relates to the radiation source focal spot and the distances for the object and detector. Similar measurements are involved in neutron radiography; a ratio of L/D is used to describe the geometry of the neutron beam. The effective diameter, or long dimension of the thermal neutron source, is noted as D ; this may be smaller than the physical hole in a neutron-attenuating collimator at the source aperture in the moderator since the neutron attenuation tends to narrow the effective source size. The value L is the source to detector distance. The geometric unsharpness, U_G , for a particular inspected object will depend on the quantities L and D and the distance the object of interest is spaced away from the detector (t), as shown in Figure 5.3. The distances L and D are indicated on the figure. The geometric

unsharpness (U_G) of an object spaced a distance t from the detection plane is calculated as follows:

$$U_G = D \left(\frac{t}{L-t} \right) \quad (\text{Eqn. 5.1})$$

For the common situation in which t is small compared to L , Equation 5.1 reduces to the following approximation:

$$U_G = \frac{D t}{L} \quad (\text{Eqn. 5.2})$$

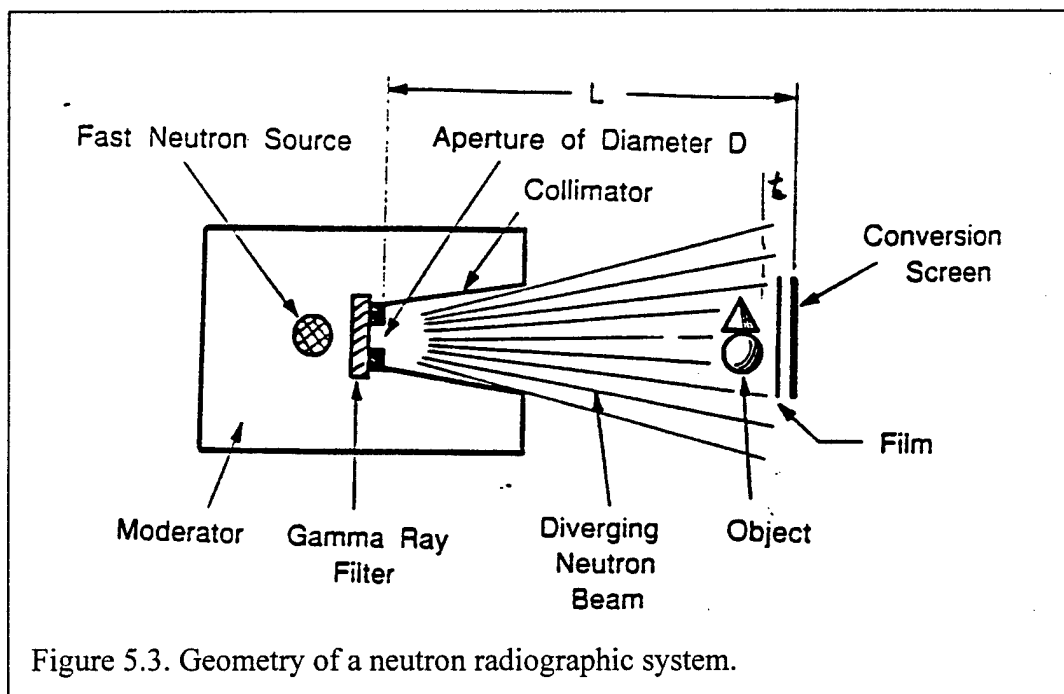
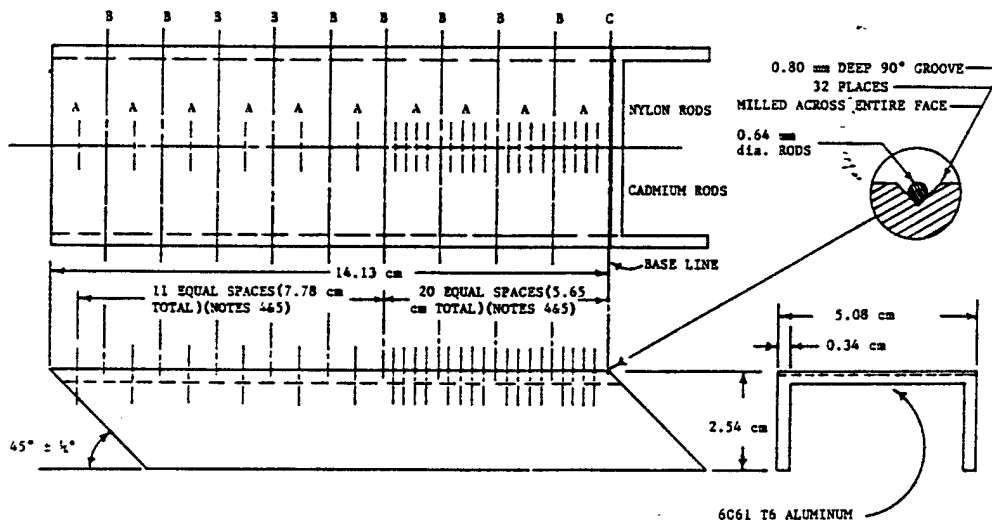

Figure 5.3. Geometry of a neutron radiographic system.

The measurement of L/D as described in ASTM E 803 (56) involves a test piece with absorbing materials (rods) spaced at various distances (t) from the detection plane. A diagram of the test piece is shown in Figure 5.4. The image of this test piece can be used for a visual measure of unsharpness (and thereby L/D) by observing where the absorbing rod images degrade. The test piece also lends itself to scanning microdensitometer measurements for more quantitative values.



- NOTE 1—Rods at “A” positions are 1 cm each side of center line (22 ea.)
 NOTE 2—Rods at “B” positions are 2 cm each side of center line (9 ea.)
 NOTE 3—Rods at “C” positions are 2.5 cm each side of center line (1 ea.)
 NOTE 4—All dimensions from base line to reduce accumulative errors
 NOTE 5—Rod arrangement shown for single system device. For an add-on device to form a double system, extend the 11 spaces for 7.78 cm to 19 spaces for 13.43 cm and eliminate the close spacing (20 for 5.65 cm)
 NOTE 6—Rods held tightly in position with one layer of transparent tape

Figure 5.4. Test piece used for measurement of L/D. This support piece is mounted at a 45-degree angle over the detector to space absorbing rods (cadmium, nylon) at various distances from the detector. (From ASTM E803, reference 56.) Reprinted with permission.

The standard describing methods for obtaining object dimensional measurements from neutron radiographs (105) outlines a procedure for examining the film density change at the edge of an object, making use of a scanning microdensitometer. Analysis of the film density vs. distance edge trace can be used to establish the object edge location to repeatability values of 25 microns and reproducibility values of 100 microns or less. These values are predicated on stringent conditions for the neutron radiographic beam, the imaging geometry and the measurement system.

These ASTM standards provide a recognized (and standardized) approach to measurements related to neutron radiography. Other documents are also available. Glossaries of neutron radiographic terms have been published by ASTM (26) and also in a military standard (MIL-STD-1948, Ref. 27). Reference 27 includes definitions for more than 150 terms. A book of reference neutron radiographs, specifically related to the inspection of nuclear fuel has proven to be a valuable reference book for the nuclear community (17). There is also an excellent collection of neutron radiographs prepared by the Japanese Society for Non-Destructive Inspection (20). Two standards for neutron radiography have been developed in France (107, 108) for the characterization of facilities and the determination of film speed and contrast. A

discussion of these and other aspects of neutron radiographic standards is given in a review by Berger and LaPorte (109). Other reviews of neutron radiographic standards are given by Haskins (110, 111) and Brenizer (112).

5.2 PERSONNEL QUALIFICATION

Neutron radiography, like other nondestructive testing procedures, requires trained, qualified people to do the testing. Training and certification of neutron radiographic operators is described in a military standard (MIL-STD-410E, Ref. 3) and in documents available from the American Society for Nondestructive Testing (1 and 2). Both documents outline the training and practical experience needed to qualify for various levels of responsibility. The basic subjects required for neutron radiographic operator training are outlined briefly in Table 5.1; additional information is available in the references cited (113, 114, 115).

Obviously a neutron radiographic operator who is already qualified in X-radiography (radiographic testing) will be relatively easier to train for neutron radiographic testing since the operator will already have basic knowledge of radiation, sources, detectors, imaging geometry, scatter, film processing and interpretation. Once the new neutron radiographer learns how neutrons are generated, attenuated and detected, the basic knowledge for performing neutron radiography will be available for use.

Table 5.1 General Training Topics for Neutron Radiographic Training

NEUTRON RADIOGRAPHIC TESTING

Fundamentals	Radiographic Testing
1. Sources <ul style="list-style-type: none"> a. X-ray b. Isotope c. Neutron <ul style="list-style-type: none"> accelerator isotope reactor neutron multiplier 	1. Basic imaging considerations
2. Detectors <ul style="list-style-type: none"> a. Imaging b. Non-imaging 	2. Test result interpretation; discontinuity indications
3. Nature of penetrating radiation and interactions with matter	3. Systems factors (source/test object/detector interactions)
4. Essentials of safety	4. Applications <ul style="list-style-type: none"> a. Explosives and pyrotechnic devices b. Assembled components c. Bonded components d. Corrosion detection e. Nonmetallic materials f. Isotopic composition

5.3 REGULATORY CONTROL

In the United States, radiation equipment is controlled by the government as a safety measure. Primary control is at the federal level with the U.S. Nuclear Regulatory Commission; this control is primarily concerned with radioactive sources and nuclear materials as described in the Atomic Energy Act of 1954 and the federal regulations (106). For neutron radiography, this federal control clearly involves radioactive neutron sources such as ^{252}Cf or $^{241}\text{Am-Be}$, etc. Sources that include nuclear fuel material for use as a sub-critical assembly are also covered by the federal regulations (51, 52), as are reactor sources.

States also have radiation control requirements. In many cases the states, known as Agreement States, have taken over parts of the regulatory control from the federal government. In addition, many states and local governments maintain control over all radiation sources, including the machine or accelerator sources not generally covered by federal regulations.

A description of the government regulatory program is given in Reference 50. The major objective of the government control is to assure safe use of radiation to protect the radiation worker and the general public.

6.0 APPLICATIONS

6.1 GENERAL APPLICATIONS

As indicated previously in Section 1, differences in attenuation between neutrons and X-rays (or gamma rays) lead to applications for each radiographic method. In general terms, thermal neutron radiography tends to complement X-radiography in that, for neutrons, there is strong attenuation for several low atomic number (Z) materials and high transmission for many high Z materials; for X-rays the situation is reversed. Observation of hydrogenous material such as a rubber "O" ring in a steel assembly can be considered for thermal neutron radiography whereas such an application would be difficult for X-radiography. In the neutron case, the attenuation of the hydrogenous rubber ring would be significant. In the X-ray case, once the X-ray energy is raised to penetrate the steel case, the X-ray attenuation in the rubber or other low Z material would be very low.

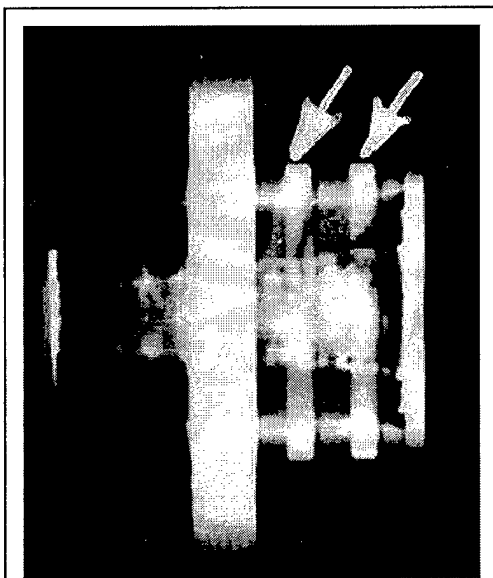

Figure 6.1. Thermal neutron radiograph of a metal assembly showing "O" rings. The arrows indicate rings that have twisted out of the groove so that they no longer seal (122). Courtesy Aerotest Operations Inc.

Clearly, considering cost and availability of equipment, X-ray or gamma ray techniques should be used where these methods will solve the problem. For situations where X-ray methods do not provide sufficient information, neutron radiography should be considered. Generally, inspection of a homogeneous material such as a steel casting, is best done by X-rays or some other NDT technique. Neutron radiography normally offers advantages for inspections of multi-material components or assemblies where it is desired to observe one material in the presence of another.

There are four general classes of application problems where neutron radiography offers advantages (1-20), as follows:

1. Detection of high neutron attenuating material in a matrix of a relatively transmitting material. Advantage may be taken of the differences between thermal neutron and X-ray attenuation as shown earlier in Figure 1.1. Contrast agents such as liquid penetrants and as described in Section 4.6 may offer advantages in certain crack detection applications. An example of low Z type of application is shown in Figure 6.1, a neutron

radiograph of a portion of an assembly, showing "O" rings inside a metal case; twisted "O" rings, that would not seal properly, are easily seen in the neutron image. Figure 4.1 showed another example, imaging of hydrogen-containing material in a steel matrix.

2. Inspection of radioactive material (taking advantage of the capability to detect neutrons without sensitivity to gamma rays, as in the transfer or track-etch detection methods). Examples of such neutron radiographs were shown in Figures 4.2, 4.3 and 4.5.

3. Detection of differences in isotopic content. Neutrons offer sensitivity to different isotopes of the same element. For example, U-238 is relatively transparent while U-235 is highly attenuating for slow neutrons. An example of a neutron radiograph of nuclear fuel showing differences in attenuation for different fuel isotopes is shown in Figure 4.5.

4. Inspection of relatively thick, neutron-transparent material because of decreased exposure time (as compared to X-ray techniques). An example would be inspection of lead shielding to detect voids.

These general classes of applications are discussed in the following sections.

Additional general information on applications may be found in many of the earlier references cited; see in particular references 1 to 20.

Table 6.1 shows typical half-value layers for thermal neutrons. Additional half-value layer information can be gained by looking at neutron cross section values (37, 41); material is also available in Ref. 55. The values listed below will suggest other applications for neutron radiography.

Table 6.1

HALF VALUE LAYER (HVL)* for THERMAL NEUTRONS

<u>MATERIAL</u>	<u>HVL (cm)</u>
Gadolinium	0.0005
Plastics	0.17-0.3
Water	0.28
Explosives (HMX, RDX, PETN)	0.43-0.54
Stainless Steel (304)	0.77
Lead	2.4
Aluminum	7.9

*From ASTM E748

6.2 AEROSPACE APPLICATIONS

The aerospace industry is a major user of neutron radiography. Applications include inspections to detect corrosion, residual core in investment cast turbine blades and residuals in other applications such as cooled rocket nozzles, inspections of explosive lines and other small explosive devices, adhesive bonds, composites and assemblies of many types to assure proper placement of components such as rubber "O" rings (see Figure 6.1).

Detection of corrosion in aircraft structures is an active application area for neutron radiography. Since corrosion products are typically hydroxides, the build-up of the corrosion product can often be detected by thermal neutron radiography before there is appreciable loss of metal; other nondestructive test methods for corrosion detection depend primarily on observation of metal loss (28, 29, 30, 44, 47, 117, 118). Examples of neutron radiographs showing images correlated with corrosion are shown in Figures 6.2 and 6.3. Figure 6.2 is a film neutron radiograph of an aluminum aircraft honeycomb structure, showing spots of corrosion after insertion of water (119). Figure 6.3 is a neutron radioscopic image showing dark areas of corrosion in an aluminum aircraft structure, taken with a reactor source and a neutron image intensifier detection system (120).

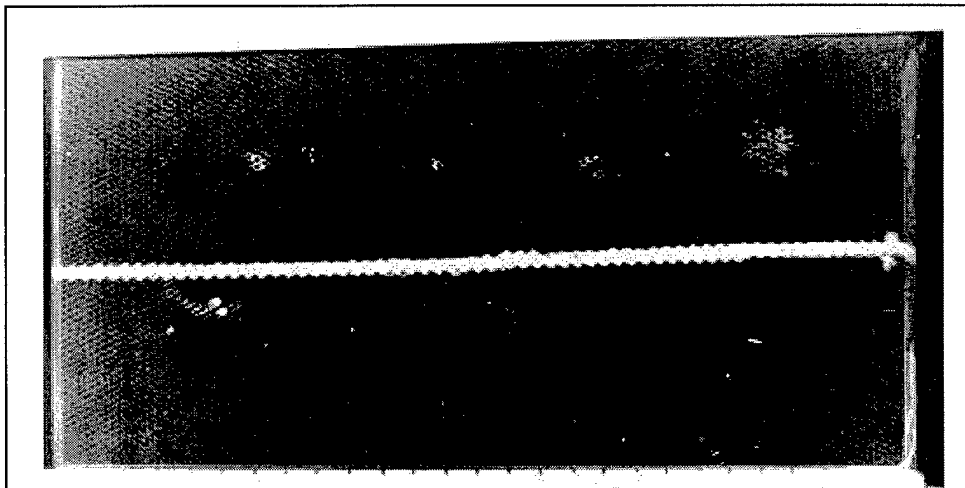

Figure 6.2 Neutron radiograph of an aluminum honeycomb structure. The white linear indication shows adhesive coupling two core sections together. The whitish spots show early indications of corrosion (119).

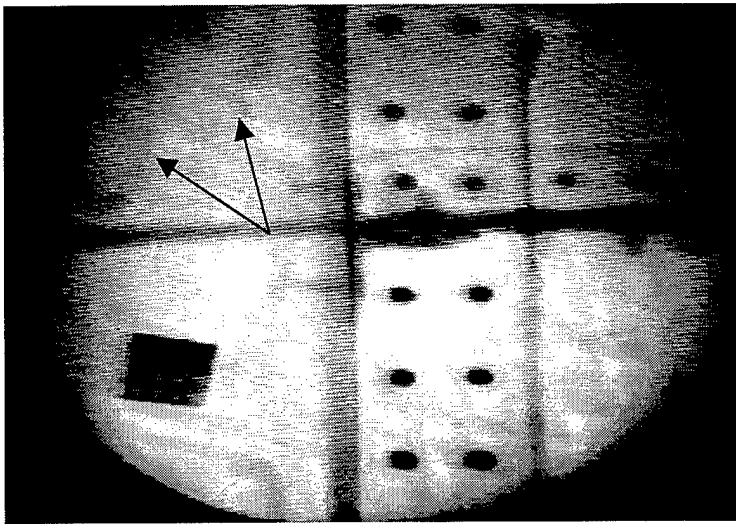

Figure 6.3 Neutron radioscopic image of an aluminum aircraft structure showing images of corrosion (dark, irregular areas, particularly in the upper left). The rectangular image at lower left shows an acrylic, stepped wedge test piece containing holes (120).

Reports describing experiments with polyethylene to simulate the hydrogen content of typical corrosion products in aluminum indicate that thermal neutron radiography will detect corrosion product build-up equivalent to 0.001 inch metal loss in aluminum (118, 120). Recent work on the use of neutron radiography to detect corrosion has led to the design and operation of a practical inspection facility for aircraft maintenance (29, 119, 121) at McClellan Air Force Base in California. The facility includes a reactor source for neutron radiography of components removed from the aircraft and a robotic system for neutron

radiography of components on the aircraft. A portion of the robotic arm and Cf-252 source assembly for this operational maneuverable neutron radiography system is shown in the photograph in Figure 6.4; the inset is an artist's design view of the maneuverable inspection system (119). Many transportable neutron radiographic systems have also been developed. Examples were shown in Figures 3.3, 3.5 and 3.6 (30, 44, 45, 46, 47, 63).

Investment-cast turbine blades are made by molding metal around a ceramic core and then leaching away the ceramic to leave open internal cooling passages. Since neutrons are sensitive to many of the rare earth materials found in ceramics, small amounts of residual core material can be detected. Sensitivity is often further enhanced by adding a few percent of gadolinia to the ceramic core material (or using a gadolinia solution wash before the neutron radiographic inspection). The addition of the high neutron cross section gadolinium material as a contrast agent permits detection of very thin residual ceramic films that might impede the thermal transfer characteristics of a turbine blade and lead to failure (103, 104, 122). Similar neutron radiographic applications have been demonstrated to detect wax cores in cooled rocket nozzles (122). An example of a turbine blade neutron radiograph was shown in Figure 4.7. Ceramic materials can also sometimes be usefully inspected by neutron radiography (122).

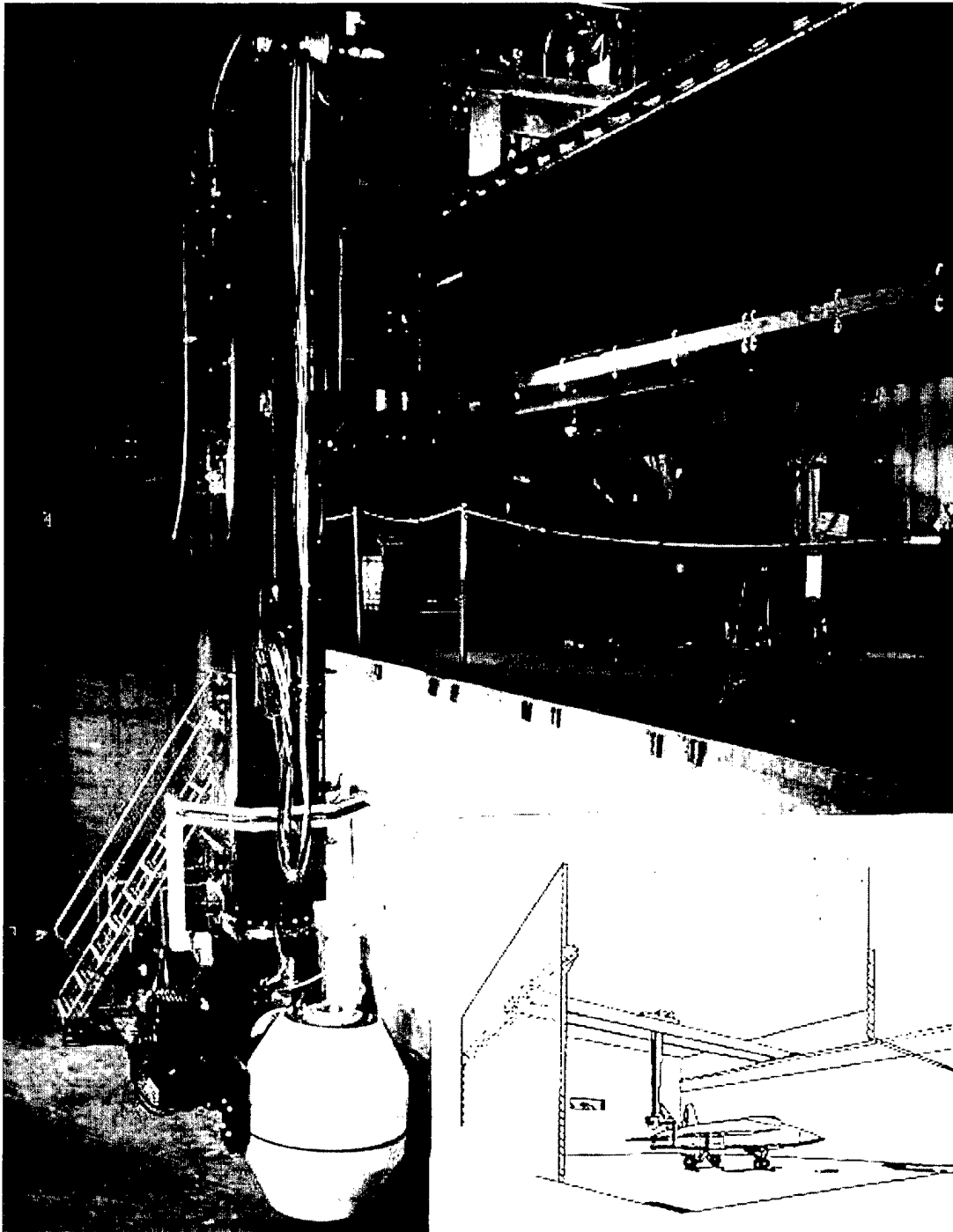

Figure 6.4 Photograph of a robotic arm at the maneuverable inspection bay at McClellan Air Force base. The large round structure at lower left is the moderator-collimator housing for the Cf-252 neutron source. The inset is a diagram of the on-aircraft inspection facility for F-111 aircraft (29, 119).

Other applications involve inspection of assemblies to detect rubber or plastic seals, detection of adhesives in bonded assemblies and inspection of explosive devices (104, 122). All these types of neutron radiographic inspections have been very valuable. The rubber or other neutron absorbing gasket material can be readily detected, even in a metallic assembly. Hydrogenous adhesives can be imaged in metallic assemblies to assure the presence of the adhesive, and sometimes the degree of the adhesive cure by observation of the bubble structure. Composite materials can be inspected to detect variations in density, resin content and excess moisture. Explosive inspection is a major application area in itself, to be covered in the following section. A typical aerospace application is the inspection of lead or stainless steel encased explosive lines of the type used to separate components and eject military pilots in emergency situations.

6.3 EXPLOSIVE DEVICES

Explosive materials typically contain neutron attenuating material such as hydrogen, lithium, or boron. Therefore, explosive materials usually shadow well on a neutron radiograph, even when encased in an assembly with metal. A typical range of thermal neutron half-value layers for explosives was given in Table 6.1. Explosive lines and bolts, detonators, and similar small explosive devices are readily inspected by neutron radiography. The purposes for the inspection may include one or more of the following:

1. Assurance that the explosive is present, in the correct location, and in the correct amount.
2. Measurement of gaps (often necessary).
3. Detection of voids, density variations, cracks, or contamination.

Neutron radiographs of explosive devices were routinely taken for many years with a Cf-252 subcritical assembly source (51, 52). Inspection of small explosive devices is also a common application at a neutron radiography service facility reactor source (104, 122). Since many of the explosive devices to be inspected are relatively small, an assembly of many devices on one radiograph is typical.

Examples of neutron radiographs of small explosive devices are shown in Figures 6.5, 6.6, 6.7 and 6.8. Figures 6.5 and 6.6 show explosive bolt images. Figure 6.7 shows a comparison of radiographs of 45-caliber ammunition, taken with thermal neutrons and x-rays (122). Figure 6.8 illustrates neutron images of explosive tips. Neutron radiographs of larger explosive devices is sometimes done even though the attenuation of thermal neutrons makes it difficult to penetrate larger devices. Such a thermal neutron radiograph is shown in Figure 6.9; the radiograph of an ordnance device 2¼ inch diameter shows detail mainly in the upper, thinner areas and in the region of the internal cracks in the central unit (123); the radiograph shows useful information that can supplement that obtained from a conventional X-ray image.

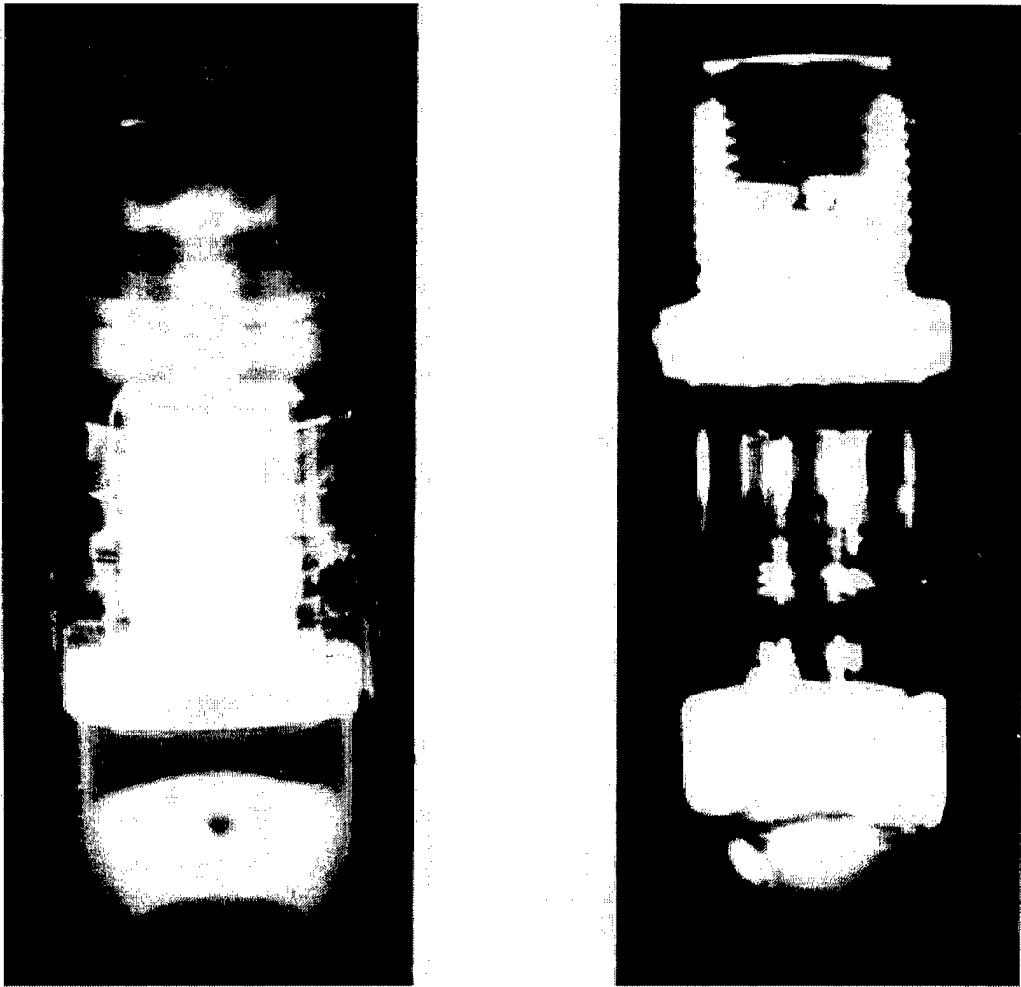

Figure 6.5 Neutron (left) and X-radiographs (right) of an explosive bolt about 2 inches high. The x-ray image shows the metallic parts. The neutron image shows plastic, epoxy, paper (slanted white line near the top) and the explosive charge (salt and pepper image near the top, inside the stainless steel cap) (34).

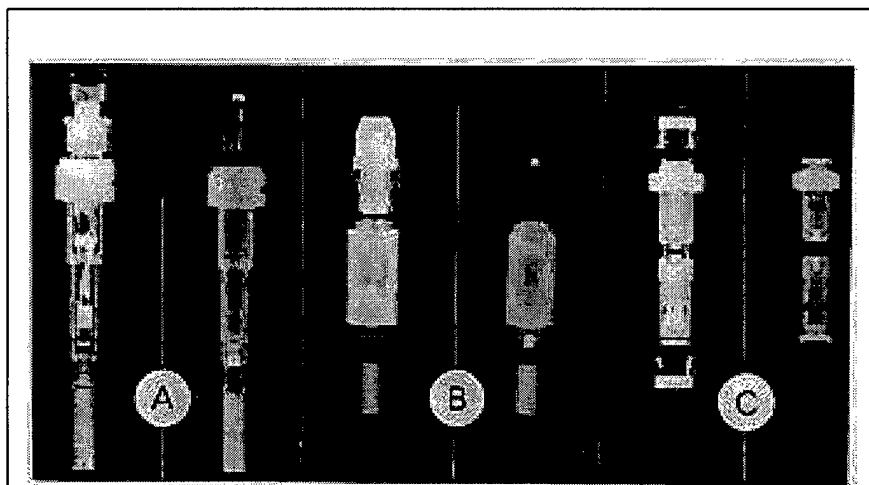

Figure 6.6 Neutron (left) and x-radiographs (right) of three explosive bolts (A, B and C) showing differences in the images (122). Courtesy: Aerotest Operations, Inc.

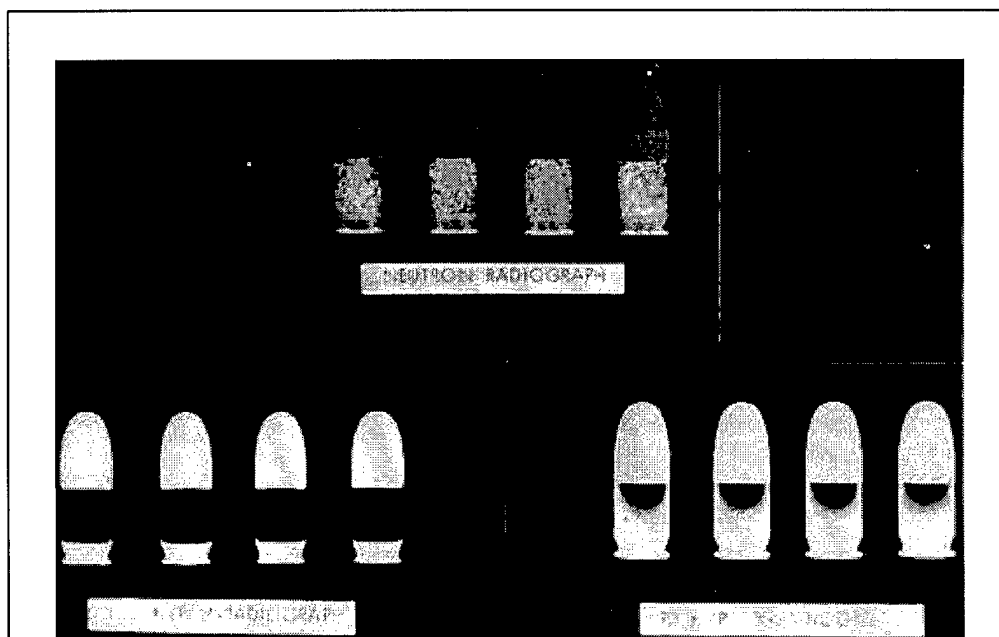

Figure 6.7 Neutron radiographs of 45-caliber ammunition (upper views) compared to x-ray images at 150 kV (lower left) and 90 kV (lower right) (122). Courtesy: Aerotest Operations, Inc.

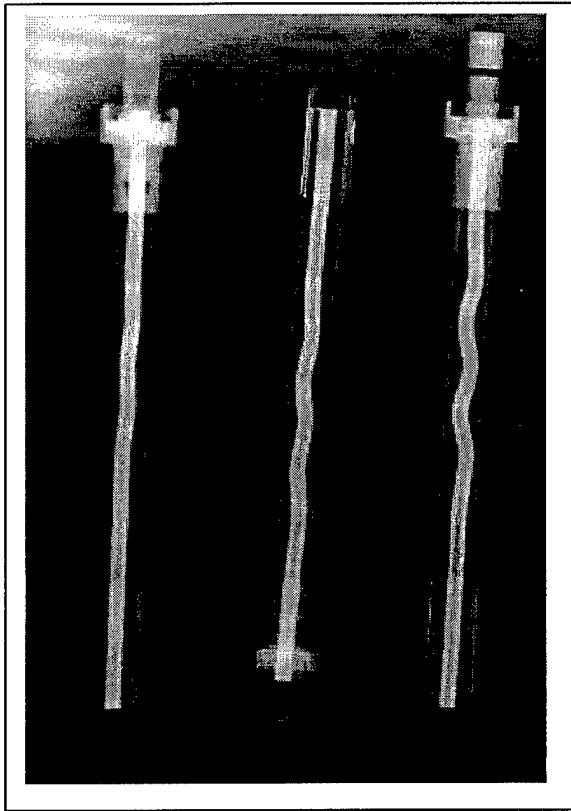

Figure 6.8 Neutron radiographs of small explosive tips used to initiate mechanical actions in remote locations.

The tip at left is satisfactory although the upper pellet shows slightly lower density. The tip at right shows separation between the two pellets. The middle sample (tip at the bottom) shows a missing pellet.

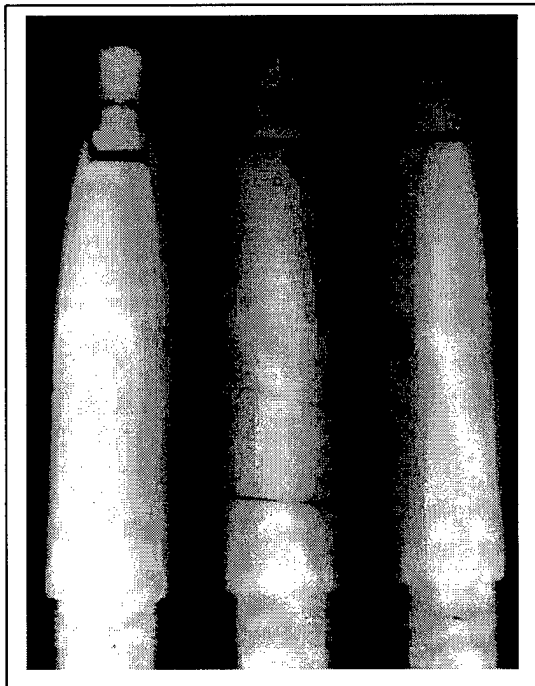

Figure 6.9 Neutron radiograph of an ordnance device, 2¾ inch diameter, showing detail near the thin top and in the cracked region at lower center. Courtesy: J. Moravec, U.S. Army Proving Ground, Yuma, Arizona.

6.4 ELECTRONIC DEVICES

The inspection of critical epoxy-potted, small electronic devices such as filters can be accomplished effectively by neutron radiography. The relatively high attenuation of the potting materials (usually hydrogenous) means that small discontinuities can be detected with neutrons, even though the assembly is in a metallic case. In addition, neutron inspection of critical relays can disclose problems with hydrogenous material, such as loose insulation, inside the relay case that could cause connection problems at an important moment. Neutron images of relays are shown in the neutron radiograph in Figure 6.10 (122).

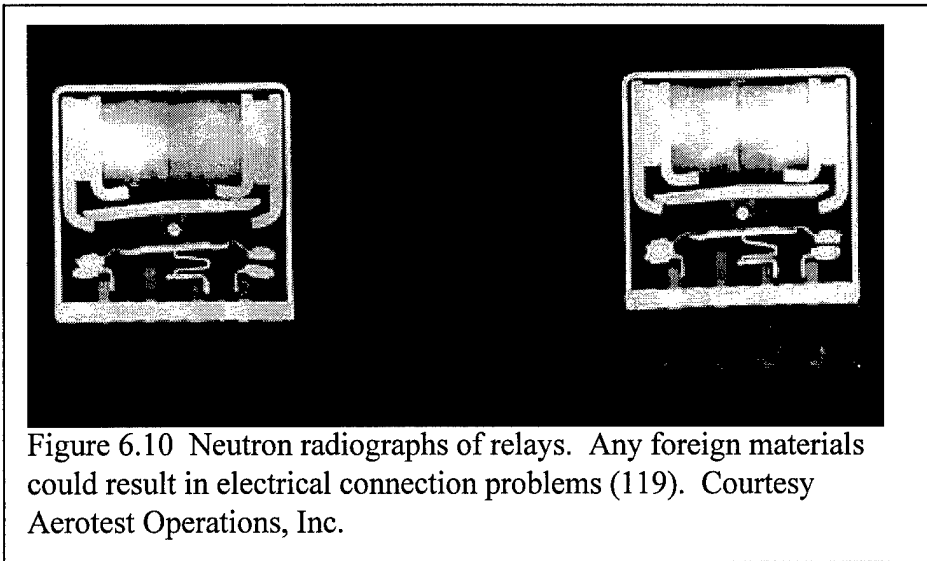

Figure 6.10 Neutron radiographs of relays. Any foreign materials could result in electrical connection problems (119). Courtesy Aerotest Operations, Inc.

Delaminations in high reliability ceramic capacitors have been successfully detected using neutron radiography, another example of neutron radiographic electronic applications (124). Because there are many effective nondestructive testing methods used for electronic devices - radiography, infrared, acoustic emission, etc. - neutron radiography is not broadly applied. However, for the types of applications indicated here, neutron radiography has contributed to improved reliability in critical electronic components.

6.5 NUCLEAR APPLICATIONS

Neutron radiographic applications started in the nuclear field (33, 34, 72). Nuclear R&D organizations generally had good neutron sources available and also experienced problems in inspecting experimental assemblies containing reactor fuel and control materials. The objects, such as irradiated spent fuel assemblies, were often highly radioactive so neutron radiographic

methods that are insensitive to gamma radiation, such as the transfer detection or track-etch methods, were ideally suited to the problem.

Applications often involved experimental fuels and other nuclear materials. Inspection was desired at intervals during irradiation tests to measure changes in dimension, from swelling for example, and to detect inhomogeneities that develop during the rigors of irradiation. Examples of neutron radiographs of some experimental reactor fuel material were shown in Figures 4.2, 4.3, and 4.5. Highly enriched fuel material is relatively opaque to thermal neutrons so the epithermal neutron radiograph shown in Figure 4.5 gives better penetration to show internal details of the irradiated fuel and the fission materials deposited in the central void of the fuel.

Nuclear applications have included examinations of nuclear fuel, both before and after irradiation. Pre-irradiation radiographs are useful for comparison after irradiation; they have also disclosed contaminating material such as plastic sheet inadvertently left inside assemblies. Entry into a fuel assembly of foreign material such as water and hydriding of metallic components has also been observed using neutron radiography (125).

Nuclear attenuating control materials have been inspected with neutron radiography as have other nuclear components such as cold traps (126). Radioactive sources can also be inspected to detect voids or other problems.

A significant capability of neutron radiography is represented by the possibility to differentiate between particular isotopes, as indicated earlier. This has been used to some degree in the nuclear field to differentiate between isotopes of fuel materials before and after irradiation and to determine burn-up in control materials. Nuclear applications of neutron radiography continue at nuclear centers around the world.

Recent work has included techniques such as tomography (84). This technique for imaging cross sections of assemblies has been particularly useful for imaging details in fuel subassemblies. These subassemblies may contain 60 or more individual fuel pins in an array. Since it is desired to inspect each pin, the subassembly must be taken apart or a technique such as tomography or laminography (127) can be used. In tomography, the radiation attenuation along many paths through the object is determined. This information is used to reconstruct the cross-sectional image of the object. For tomography of nuclear fuel, many radiographs taken at different angular orientations can be digitized to obtain the initial data. As few as 75 views can be used to obtain the initial data (84) for reconstruction.

6.6 MOTION/DYNAMIC APPLICATIONS

Neutron time lapse radiographs and dynamic detectors such as neutron image intensifiers and scintillator-camera systems have been used to obtain information about dynamic events. Demonstrations of capability have been made to observe thermal expansion of nuclear fuel

material and to follow liquid metal in the casting process (see Figure 4.4). Application studies in ballistics have required very fast image frame rates to obtain useful data from rapid motion. This has been accomplished with a pulsed reactor and high speed cameras. Images have been observed at rates as high as 10,000 frames/second (77).

A number of neutron applications for dynamic events have been pursued with conventional television frame rates (30 frames/second) using television cameras and new solid state cameras to detect the light from neutron scintillators or neutron image intensifier tubes. Applications have included observations of fluid flow in metallic assemblies, for example, investigations of heat pipes to optimize the fluid flow and the heat transfer of the system (128). Extensive motion studies of lubricants and fuels have been conducted in engines and engine components to learn more about the dynamics (76, 78, 79, 80, 81, 130, 131). Some of this work has been done with lower energy, cold neutrons (78) in order to provide greater sensitivity to the hydrogenous fluid, and greater penetration through the surrounding metal. An example of results from an engine study is given in Figure 6.11. The two neutron radiosopic images show a GEM turboshaft engine, one a static view (left) and the other a dynamic view (right). The oil scavenge pipe (slightly bent pipe at lower center of the images) is shown full of oil in the static view but with very little oil in the dynamic view. The neutron radiosopic tests led to a redesign of the engine to permit oil to flow freely during engine operation (78).

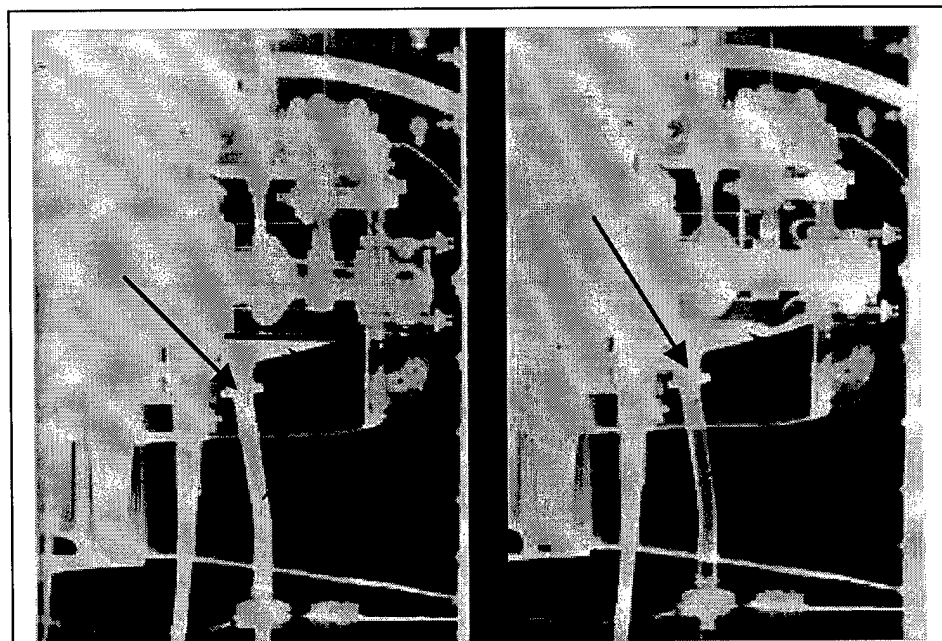

Oil Scavenge
full of oil
(left)

Pipe not full
of oil (right).

Figure 6.11. Neutron radiosopic images of a GEM turboshaft engine. Left is a static view. Right is a dynamic view, engine running. The images show that the oil scavenge pipe (lower center) has little oil in it during operation, an indication of poor oil circulation (78).

Dynamic neutron imaging studies have also been used for a variety of other applications, including real-time inspection applications to detect aircraft corrosion, hydrogen locations in titanium, and to study pneumatic systems, filters and moisture/water migration (29, 44, 47, 82, 85, 87).

6.7 MISCELLANEOUS APPLICATIONS

There are many neutron inspection applications that have not been specifically cited. Many such applications are discussed in References 1 to 20.

There have been medical/biological investigations for neutron radiography. For in-vivo applications, the results have been relatively negative (132); the extensive neutron attenuation of tissue presents problems in penetration and dose. Biological work on excised samples, however, has produced useful results. Neutron radiography has been shown to be useful for detecting and confirming the extent of tumors in bones removed from patients (133). New neutron radiographic results to show application of neutron radiography to detect lung cancer in mice have shown promise, mainly as a result of extensive image processing (134).

Diffusion studies have been successfully done to observe the movement of water/moisture in concrete samples as a function of time/temperature, as well as water movement in plants (135, 136). Movement of smoke, aerosols and contrast media through filters has been investigated (137, 138, 139). Soils have been investigated to complement X-radiographic results (140, 141).

Metallographic data have been obtained in studies of metals containing a neutron-opaque material such as cadmium or boron, for observations of hydrogen in metals, and of investigations of brazing materials. The techniques have included microneutron radiography and neutron-induced auto-radiography. In the latter technique, neutron exposure leads to the emission of radiation such as alpha particles which can be detected to reveal locations of boron or lithium in the metal sample. Microneutron radiography is usually done with thin gadolinium converter screens and slow, fine-grain emulsions. The resultant radiograph can be enlarged to factors approaching 100X to show detail in the order of 10 microns (142). Other metallurgical applications in steels and aluminum alloys have been reported (143, 144).

Art objects and historical artifacts represent another application area for neutron radiography. The complementary nature of neutron radiography often reveals details that cannot readily be detected by other methods (145, 146, 147). An example of a neutron radiograph of a rare historical object is shown in Figure 6.12 (146). The object was a lead vessel about 25 cm in height, dating from the Western Chou period in China, approximately 1000 B.C. Neutrons easily penetrated the lead walls of the vessel to show evidence of early repairs and to confirm that the vessel was empty. X-ray tests were inconclusive because of the significant attenuation of the lead walls. This neutron radiograph was taken by a xeroradiographic method using a gadolinium oxysulfide conversion screen. The xeroradiographic detection method used for this application

serves to illustrate that any method that can be used for X-ray inspection can be considered for neutron radiography.

A related neutron technique in the art world involves neutron autoradiography of paintings. Neutron exposure excites radioactive emissions from the paint pigments. These can be studied as a function of time after the neutron radiation is complete to produce images from different paint materials. The method is used to bring out underlying paintings, to verify authenticity, and to study artist's technique (147, 148).

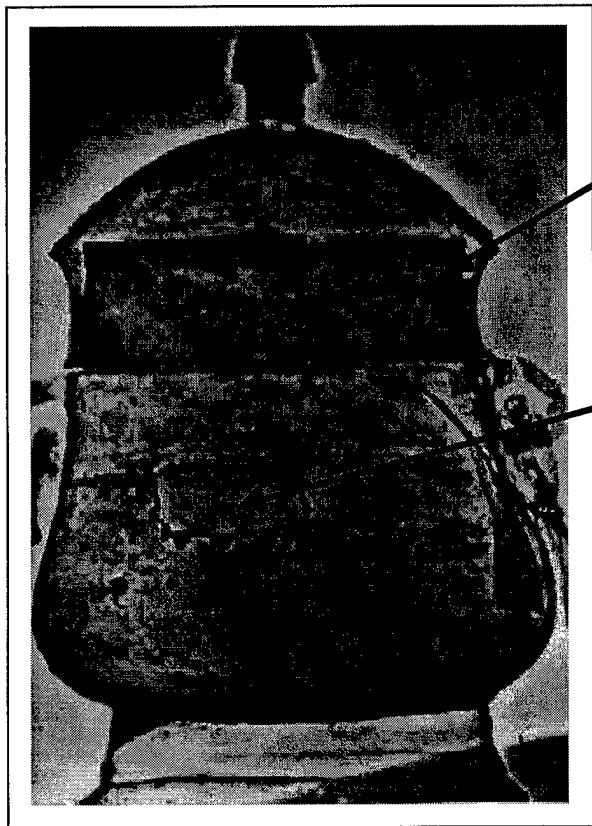

Black areas show corrosion

Indication of early repair

Figure 6.12 Neutron xeroradiograph of a lead vessel, dating back to about 1,000 B.C. The image shows the vessel is empty and also outlines the dark shadows of corrosion along the walls and at the cover, which was corroded closed (146).

7.0 CONCLUSIONS

Neutron radiography continues to offer inspection solutions for many difficult problems, as has been discussed throughout this review of the technology. Significant advances have been realized in recent years in terms of neutron sources and electronic imaging techniques. Sources now available include a range of accelerators that can be considered for either fixed installation or transportable systems. Cold neutron sources, including guide tube techniques that bring a gamma-free neutron beam to a position remote from the reactor source, are now more readily available for neutron research and radiography and the special problems that can be solved by the use of these very low energy neutrons (151). Electronic image systems for slow and fast neutrons have been described, offering large fields-of-view and prospects for improved sensitivity and spatial resolution (73). The combination of high output accelerator sources and electronic image detection is leading to consideration of practical aircraft inspection systems that offer good economic potential for early detection of corrosion.

Standards for neutron radiography continue to advance and mature as experience is gained with the existing standards. Active standards work continues in ASTM, through Committee E-7 on Nondestructive Testing and internationally through ISO, the International Organization for Standardization; the group directly involved internationally is ISO/TC 135/SC 5/ WG 4, under the auspices of ISO-Technical Committee 135, Nondestructive Testing, Radiation Subcommittee 5 and the Neutron Radiography Working Group 4. Current contact (1998) for the neutron radiography standards work in both ASTM and ISO is Dr. Jack Brenizer, University of Virginia. Brenizer is the Chairman of ASTM Subcommittee E 7.05 and the Convenor of the ISO Working Group. Contact with Brenizer may now be made at the Pennsylvania State University in University Park, PA.

As implied in the description of the standards work, there is strong neutron radiography activity in the international community. In Europe, an active group is the European Neutron Radiography Working Group (ENRWG), which includes representatives from many of the European centers. A current contact for the ENRWG is Dr. Márton Balaskó, KFKI Atomic Energy Research Institute in Budapest, Hungary. In Japan, where many neutron radiography research and application programs are under way, there is an active neutron radiography group organized under the auspices of the Japan Atomic Energy Research Institute (JAERI), Tokai Establishment; a contact is Dr. Shigenori Fujine at the Research Reactor Institute at Kyoto University in Osaka. A new technical society has been formed to address issues relative to neutron radiography, the International Society for Neutron Radiology (8); the current President is Dr. Keiji Kanda, Research Reactor Institute, Kyoto University in Osaka. Complete addresses for the people named in this international activity paragraph can be found in recent international conference proceedings (8, 10, 11).

Neutron radiographic service work is available from at least two organizations in the United States. Aerotest Operations, Inc., San Ramon, CA and General Electric, Nuclear Test Reactor, Vallecitos, CA are known to provide commercial neutron radiographic service, including the

capability to inspect explosive devices. In Canada commercial neutron radiographic service is available from NRAY Services, Inc., Petawawa, Ontario. In addition, several foreign centers offer such services; contacts may be made through the ENRWG or JAERI. Limited neutron radiographic services are also made available occasionally through university neutron radiographic centers on a case-by-case basis. Contacts for such services may be found in current conference proceedings (8, 10, 11).

The future for neutron radiography appears promising, both in terms of research and applications. Research activity continues at a high level, as indicated in the number of papers and attendees at neutron radiographic meetings. A growing number of practical applications has been demonstrated at these periodic conferences. In addition, the extensive neutron radiographic facilities for aircraft inspection at the Air Force Air Logistics Center, McClellan Air Force Base in Sacramento, CA are coming to the attention of the aircraft community. In 1998 the Federal Aviation Administration issued an Air Agency Certificate for that facility for a broad range of nondestructive inspection techniques, including neutron radiography, for inspection of selected commercial aircraft (152). The likely impact of this event will be the introduction of several more aircraft inspection facilities around the world, each offering neutron radiographic inspection for early detection of corrosion.

Looking toward the future, there are many opportunities for advanced techniques and applications in the field of neutron radiography. Since image detection methods used for x-rays have been relatively easily transferred for neutron imaging use, one can envision that new, emerging, electronic x-ray image methods will be adapted for neutron use (154). Initial work has already been reported on the use of photostimulable phosphor plates for neutron radiographic use (94, 95, 96). These storage phosphor detectors are re-usable, thereby eliminating the continuing cost of film and easing environmental problems in the use and disposal of film processing chemicals. In addition, the storage phosphor technique offers wide dynamic range, digital imaging.

Another rapidly maturing x-ray imaging technology is the flat panel, a large area, solid state detector, such as amorphous silicon, made up of combinations of photodiodes and an integral thin film transistor (154, 155). These image panels also offer the wide dynamic range, digital imaging advantages indicated above for the storage phosphor, plus the capability for dynamic response. The panels are showing advantages for medical diagnostic x-ray imaging, as well as industrial applications over a broad range of x-ray energies, from less than 100 keV to the MeV range.

There are advances in non-reactor neutron sources, as described in Section 3.4. Developments include high neutron yield linear accelerators, cyclotrons and low voltage (d, T) sources (28). Fast neutron yields from these sources are in the order of 10^{11} to 10^{12} n/s, outputs that give these sources neutron radiographic image quality approaching those from reactor beams. In addition, portability is being investigated more vigorously, as shown in Figures 3.3, 3.5 and 3.6. The combination of high yield, transportable neutron sources and electronic neutron imaging offers promise for increased application of this inspection technique.

Neutron energy ranges outside of cold neutrons, the widely used thermal energy range and the sometimes used near-epithermal neutron energy range (see Figure 4.5), also offer promise for further development and application. Resonance energy neutrons, as described in Table 1.1, can show exceptional sensitivity for particular materials such as indium or gold, materials that show resonance response in the near epithermal energy range (12). A real application for resonance neutron radiography would advance the field. Epithermal neutrons in the 1,000 or more ev range offer reasonable prospects for materials discrimination contrast approaching that of thermal neutrons, while also providing much improved neutron transmission through thick objects. An inspection such as the ordnance devices shown in Figure 6.9, for example might benefit from the use of high epithermal neutrons.

Opportunities for future advances in neutron radiography are likely as research and development work continues to more fully explore neutron energies, sources and detectors and the opportunities these developments may offer.

8.0 REFERENCES

1. Anon., "Recommended Practice," SNT-TC-1A, American Society for Nondestructive Testing, Columbus, OH, 1996.
2. Anon., "ASNT Standard for Qualification and Certification of Nondestructive Testing Personnel," ANSI/ASNT CP-189-1996, American Society for Nondestructive Testing, Columbus, OH, 1996.
3. Anon., "Nondestructive Testing Personnel Qualification and Certification," MIL-STD-410E, 1974.
4. Barton, J.P. and von der Hardt, P., Editors, "Neutron Radiography - 1," Proceedings of the First World Conference, D. Reidel Publishing Co., Dordrecht, Holland, 1983.
5. Barton, J.P., Farney, G., Person, J.L. and Rottger, H., Editors, "Neutron Radiography - 2," Proceedings of the Second World Conference, D. Reidel Publishing Co., Dordrecht, Holland, 1986.
6. Fujine, S., Kanda, K., Matsumoto, G. and Barton, J.P., Editors, "Neutron Radiography - 3," Proceedings of the Third World Conference, Kluwer Academic Publishers, Dordrecht, Holland, 1990.
7. Barton, J.P., Editor, "Neutron Radiography - 4," Proceedings of the Fourth World Conference, Gordon and Breach, Langhorne, PA, 1993.
8. Fischer, C.O., Stade, J. and Bock, W., Editors, "Neutron Radiography - 5," Proceedings of the Fifth World Conference, Deutsche Gesellschaft fur Zerstorungsfreie Prufung e.V., Berlin, 1997
9. MacGillivray, G.M. and Brenizer, J.S., Jr., Editors, "Neutron Radiography System Design and Characterization," Proceedings of the First Topical Meeting, Pembroke, Canada, 1990.
10. Mochiki, K. and Kobayashi, H., Editors, "Neutron Radiography System Design and Characterization - 2," Proceedings of the Second International Topical Meeting, Rikkyo University, Japan, 1995.
11. Lehmann, E., Pleinert, H. and Koerner, S., Editors, "Neutron Radiography System Design and Characterization - 3," Lucerne, Switzerland, March, 1998. Proceedings to be published in Nuclear Instruments and Methods, Section A.

12. Berger, H., "Neutron Radiography - Methods, Capabilities and Applications," Elsevier Publishing Co., Amsterdam, 1965. Now available in revised, photocopy form from Industrial Quality, Inc., Gaithersburg, MD, 1995.
13. Hawkesworth, M.R., Editor, "Radiography with Neutrons," British Nuclear Energy Society, London, 1973.
14. Berger, H., Editor, "Practical Applications of Neutron Radiography and Gaging," ASTM STP 586, American Society for Testing and Materials, West Conshohocken, PA, 1976.
15. "Neutron Radiography Issue," Atomic Energy Review, Vol. 15, No. 2, pp. 121-368, 1977.
16. von der Hardt, P. and Rottger, H., Editors, "Neutron Radiography Handbook," D. Reidel Publishing Co., Dordrecht, Holland, 1981.
17. Domanus, J.C., Editor, "Reference Neutron Radiographs of Nuclear Reactor Fuel," D. Reidel Publishing Co., Dordrecht, Holland, 1984.
18. Berger, H., Cutforth, D.C., Garrett, D.A., Haskins, J., Iddings, F.A. and Newacheck, R.L., "Neutron Radiography," Nondestructive Testing Handbook, Second Edition, Vol. 3, Section 12, Radiography and Radiation in Testing, L.E. Bryant, Editor, pp. 532-563, American Society for Nondestructive Testing, Columbus, OH, 1985.
19. Barton, J.P., "Implementation of Neutron Radiography," Nondestructive Testing Handbook, Second Edition, Vol. 3, Section 13, Radiography and Radiation in Testing, L.E. Bryant, Editor, pp. 564-592, American Society for Nondestructive Testing, Columbus, OH, 1985.
20. Hiraoka, E., Chief Editor, "Collected Neutron Radiographs in Japan," Japanese Society for Non-Destructive Inspection, Tokyo, Japan, 1996.
21. Anon., "Buyer's Guide", Nuclear News, Vol. 41, No. 4, pp. 133-137, 1998.
22. Anon., "Radiography in Modern Industry," Eastman Kodak Co., Rochester, NY, 1980.
23. Halmshaw, R., "Industrial Radiology - Theory and Practice," Applied Science Publishers, London, 1982.
24. Bryant, L.E. and McIntire, P., Editors, "Radiography and Radiation Testing," Nondestructive Testing Handbook, Second Edition, Vol. 3, American Society for Nondestructive Testing, Columbus, OH, 1985.

25. Becker, G.L., Editor, "Radiographic NDT," E.I. du Pont de Nemours Co., Wilmington, DE, 1990.
26. Anon., "Standard Terminology for Nondestructive Examinations," ASTM Standard E 1316-97a, American Society for Testing and Materials, West Conshohocken, PA, 1997.
27. Anon., "Glossary of Terms and Definitions for Neutron Radiographic Testing," MIL-STD-1948, 1985.
28. Berger, H. and Dance, W.E., "Accelerator-Based Neutron Radioscopic Systems," Invited Paper, 15th International Conference on the Application of Accelerators in Research and Industry, University of North Texas, November, 1998, to be published AIP Proceedings, 1999.
29. Shields, K. and Richards, W.J., "Aircraft Inspection Using Neutron Radioscopic Techniques," SPIE Vol. 2455, pp. 133-144, 1995.
30. Lanza, R.C., "The Use of Neutron Tomographic Techniques for the Detection of Corrosion in Aircraft Structures," ASME, Vol. AD-47, pp. 253-259, 1995.
31. Kallmann, H., "Neutron Radiography," Research, Vol. 1, No. 6, pp. 254-260, 1948.
32. Peter, O., "Neutronen-Durchleuchtung," Zeitschrift für Naturforschung, Vol. 1, No. 10, pp. 551-559, 1946.
33. Thewlis, Jr., "Neutron Radiography," British Journal of Applied Physics, Vol. 7, pp. 345-350, 1950.
34. Berger, H., "Early Development of Neutron Radiography in the U.S.A.," Materials Evaluation, Vol. 49, pp. 1202-1214, 1991.
35. Imel, G.R. and McClellan, G.C., "Survey of Neutron Radiography Facilities," Ref. 8, pp. 524-528, 1995.
36. Hawkesworth, M.R., "Neutron Radiography: Equipment and Methods," Ref. 15, pp. 169-220, 1977.
37. Hughes, D.J. and Schwartz, R.B., "Neutron Cross Sections," Report BNL-325, Second Edition and Supplements, Brookhaven National Laboratory, Upton, NY, 1958-1973 (supplements issued periodically).
38. Beckurts, K.H. and Wirtz, K., "Neutron Physics," Springer-Verlag, Berlin, New York, 1964.

39. Curtiss, L.F., "Neutron Physics," Van Nostrand, Princeton, NJ, 1959.
40. Feld, B.T., Part VII in *Experimental Nuclear Physics*, Vol. 2, E. Segré, Editor, pp. 208-586, Wiley, NY, 1953.
41. Hughes, D.J., "Neutron Cross Sections," Pergamon Press, London, New York, Paris, 1957.
42. Hughes, D.J., "The Neutron Story," Doubleday, Garden City, NY, 1959.
43. Stranathan, J.D., "Particles of Modern Physics," Blackiston Co., Philadelphia, 1946.
44. Antal, J.J., Dance, W.E., Moravec, J.D. and Carollo, S.F., "Experience with an On-Off Mobile Neutron Radiography System," Ref. 5, pp. 407-414, 1986.
45. Cluzeau, S., Le Tourneur, P., Dance, W.E., "Upgrade of the DIANE: Performance Improvement in Thermalization of Fast Neutrons for Radiography," 14th International Conference on Applications of Accelerators in Research and Industry, Denton, TX, Nov. 6-9, 1996.
46. Hamm, R.W., "Status of the LANSCAR Neutron Generators," Ref. 8, pp. 540-547, 1995.
47. Allen, D.A., Hawkesworth, M.R., Beyon, T.D., Green, S., Rogers, J.D., Allen, M.J., Plummer, H.C., Boulding, N.J., Cox, M. and McDougall, I., "Neutron Radiography Using a Transportable Superconducting Cyclotron," Nuclear Instruments and Methods in Physics Research, Section A, Vol. 353, pp. 128-133, 1994.
48. Lehmann, E. and Pleinert, H., "The New Neutron Radiography Station at the Spallation Source, SINQ," Insight, Vol. 40, pp. 192-194, 1998.
49. Wilson, L.E., Hildreth, G.A. and Fussa, A.D., "Industrial Development and Application of the Van de Graaff Accelerator for Neutron Radiography," Materials Evaluation, Vol. 29, No. 4, pp. 69-74, 1971.
50. Kerr, G.W., "Regulatory Control for Neutron Radiography," Ref. 14, pp. 93-105, 1976.
51. Crosbie, K.L., Preskitt, C.A., John, J. and Hastings, J.D., "Californium Multiplier Part I: Design for Neutron Radiography," Materials Evaluation, Vol. 40, p. 579-583, 1982.
52. Hastings, J.D., Crosbie, K.L., Preskitt, C.A. and John, J., "Californium Multiplier Part II: Performance of the Mound System," Materials Evaluation, Vol. 40, p. 584-589, 1982.
53. Anon., "International Basic Safety Standards of Radiation Sources: A Safety Standard." Safety Series No. 115, Report No. STI/PUB/993, International Atomic Energy Agency, Vienna, 1996.

54. Anon., "Questions and Answers Based on the 10 CFR Part 20", NUREG/CR 6204, Nuclear Regulatory Commission, Washington, DC, 1994.
55. Anon., "Standard Practice for Thermal Neutron Radiography of Materials," ASTM Standard E 748, American Society for Testing and Materials, West Conshohocken, PA, 1995.
56. Anon., "Standard Test Method for Determining the L/D Ratio of Neutron Radiography Beams," ASTM Standard E 803, American Society for Testing and Materials, West Conshohocken, PA, 1996.
57. Brenizer, J.S., Berger, H., Stebbings, C.T. and Gillies, G.T., "Performance Characteristics of Scintillators for Use in an Electronic Neutron Imaging System for Neutron Radiography," Review of Scientific Instruments, Vol. 68, No. 9, pp. 3371-3379, September, 1997.
58. Cluzeau, S., Le Tourneur, P. and Dance, W.E., "Upgrade of the DIANE: Performance Improvement in Thermalization of Fast Neutrons for Radiography," AIP Conference Proceedings 392, pp. 887-890, 1996.
59. Huriet, J. and Cluzeau, S., SODERN Exhibit at 6th European Conference on Nondestructive Testing, Nice, France, October 24-28, 1994.
60. Cassidy, J.P., "Use of a Low-Energy Van de Graaff Accelerator in Neutron Radiography of Encased Explosives," Ref. 14, pp. 117-124, 1976.
61. Swanson, F.R. and Kuehne, F.J., "Neutron Radiography with a Van de Graaff Accelerator for Aerospace Applications," Ref. 14, pp. 158-167, 1976.
62. Hunt, C.A., "Neutron Radiography with a 5.5 MeV Linear Accelerator Beryllium Source," *British Journal of NDT*, Vol. 11, pp. 78-85, 1969.
63. Gillespie, G.H., McMichaels, G.E., Micklich, B.J. and Imel, G.R., "RFQ-Based, Transportable, High Resolution Neutron Radiography Concept," Ref. 8, pp. 532-539, 1996.
64. Chia, W-M., Chung-Sheng, C., Taun-ran, Y., "Conceptual Design of the INER Cyclotron Based Neutron Radiography Facility," Nuclear Instruments and Methods in Physics Research, Section A, Vol. 377, pp. 27-31, 1996.
65. Wilson, M.N. and Finlan, M.F., "The Superconducting Cyclotron as a Transportable Neutron Source," Ref. 5, pp. 199-206, 1986.

66. Cluzeau, S. and Le Tourneur, P., "Upgrade of the DIANE: Performance," Ref. 8, pp. 512-518, 1996.
67. Knoll, G.F., "Radiation Detection and Measurement," J. Wiley & Sons, NY, 1979.
68. Berger, H., "Track-Etch Radiography: Alpha, Proton, Neutron," Nuclear Technology, Vol. 19, pp. 188-198, 1973.
69. Barbalat, R., "Use of Cellulose Nitrate for Neutron Radiographic Testing of Burned Fuel Elements," Ref. 4, pp. 747-753, 1983.
70. Berger, H., "Detection Systems for Neutron Radiography," Ref. 14, pp. 35-57, 1976.
71. Berger, H., "Radiographic Nondestructive Testing," ASTM Standardization News, Vol. 3, No. 3, pp. 21-29, 1975.
72. Berger, H. and Beck, W.N., "Neutron Radiographic Inspection of Radioactive Irradiated Reactor Fuel Specimens," Nuclear Science and Engineering, Vol. 15, No. 4, pp. 411-414, 1963.
73. Brenizer, J.S., Berger, H., Gibbs, K.M., Mengers, P., Stebbings, C.T., Polansky, D. and Rogerson, D.J., "Development of a New Electronic Neutron Imaging System," Paper presented at the Third International Topic Meeting on Neutron Radiography, Lucerne, Switzerland, March 16-19, 1998, Nuclear Instruments and Methods, Section A, in press.
74. Kobayashi, H., Kubota, Y., Shibata, H. and Tagawa, S., "Development of New NR Converter Using Pyrolytic Boron Nitride Plate," Ref. 7, pp. 771-778, 1993.
75. Tsukimura, R.R., "A Boron Nitride Conversion Screen," Ref. 8, pp. 237-239, 1996.
76. Lindsay, J.T., Brannon, C.C., McGregor, D.S. and Olsen, R.W., "A Solid State Position Sensitive GaAs Device as a Neutron Camera," Ref. 8, pp. 240-248, 1996.
77. Bossi, R.H., Robinson, A.H. and Barton, J.P., "High Frame-Rate Neutron Radiography of Dynamic Events," Ref. 4, pp. 643-651, 1983.
78. Stewart, P.A.E. and Heritage, J., "Cold Neutron Fluoroscopy of Operating Automotive Engines," Ref. 4, pp. 635-642, 1983.
79. Lindsay, J.T., Kaufman, C.W., Jones, J.D., Tullis, B.P., Hibiki, T., Wright, S.J., Mishima, K., Fujine, S., Yoneda, K., Elam, S., Koblish, T., Lee, P., McAuliffe, D., Jasti, J.K. and Fogler, H.S., "A Summary of Neutron Radiography and Neutron Radioscopy Applications at the University of Michigan Memorial Laboratory," Ref. 7, pp. 324-332, 1993.

80. Lindsay, J.T., Fujine, S., Mishima, K., Hibiki, T., Yoneda, K., Kobayashi, K., Matsubayashi, M. and Islam, M.N., "Coking Determination in Gas Turbine Engine Nozzles Using Neutron Radiography," Ref. 8, pp. 571-577, 1996.
81. Lindsay, J.T. and Schoch, P., "X-Ray Vision on Steroids," Machine Design, Vol. 70, No. 6, pp. 49-51, April, 1998.
82. Norris, P.M., Brenizer, J.S., Raine, D.A. and Bostain, D.A., "Measurement of Water Deposition in Aerogel by Neutron Radioscopy," Ref. 8, pp. 602-609, 1996.
83. Anon., "Standard Guide for Computed Tomography (CT) Imaging," ASTM Standard E 1441, American Society for Testing and Materials, West Conshohocken, PA, 1995.
84. McClellan, G.C. and Tow, D.M., "Neutron Tomography of Damaged Reactor Fuel Assemblies," Ref. 4, pp. 711-718, 1983.
85. Wade, R.J., Crump, J.C. III and Shields, K., "Neutron Tomography Investigation of Aircraft Fan Blades," 41st International SAMPE Symposium, Materials and Process Challenges: Aging Systems, Affordability, Alternative Applications, Vol. 41, Book 1, pp. 243-250, 1996.
86. Shillinger, B., Ludwig, W., Rausch, C., Wagner, U., Gebhard R. and Haas, B., "3D Neutron Tomography in Material Testing and Archeology," Ref. 8, pp. 688-693, 1996.
87. McFarland, E.W., Leigh, J. and Lanza, R., "Detection and Characterization of the Heterogeneous Distribution of Hydrogen in Titanium Compressor Blades by Neutron Computed Tomography," Journal of Advanced Materials, Vol. 26, No. 3, pp. 3-10, 1995.
88. Hall, J., Dietrich, F., Logan, C. and Schmid, G., "Development of High-Energy Neutron Imaging in Support of Enhanced Surveillance Program Applications," 25th Annual Symposium on Quantitative NDE, July, 1998.
89. Klann, R.T., "Fast Neutron (14.5 MeV) Radiography: A Comparative Study," Ref. 8, pp. 469-483, 1996.
90. Yoshii, K. and Kobayashi, H., "Characterization of the YAYOI Fast Neutron Radiographic Field," Nuclear Instruments and Methods in Physics Research, Section A, Vol. 377, pp. 68-71, 1996.
91. Berger, H., "Some Experiments in Fast Neutron Radiography," Materials Evaluation, Vol. 27, pp. 245-253, 1969.
92. Criscuolo, E.L. and O'Connor, D.T., "Ionography - A New Process of Radiographic Imaging," Nondestructive Testing, Vol. 14, No. 2, pp. 28-30, 1956.

93. Scott, P.B., Johnson, S.E., Watson, G.W. and Berger, H., "Neutron Radiographs Using the Ionographic Process," Journal of Applied Physics, Vol. 49, pp. 5078-5080, 1978.
94. Luckey, G., "Apparatus and Methods for Producing Images Corresponding to Patterns of High Energy Radiation," U.S. Patent 3,859,527, 1975, Revised 1985.
95. Wysnewski, D. and Wysnewski, R., "Computed Radiography" in *Nondestructive Evaluation of Aging Aircraft, Airports, Aerospace Hardware and Materials*, Tobey Cordell and Raymond Rempt, Editors, SPIE Vol. 2455, pp. 125-132, 1995.
96. Kinsella, T.E., Yeager, M.J. and Soltani, P.K., "Issues Associated with the Implementation of Phosphor Imaging in Industrial Radiography," Materials Evaluation, Vol. 56, No. 4, pp. 540-545, 1998.
97. Cipriani, F., Castagna, J.-C., Lehmann, M.S. and Wilkinson, C., "A Large Image-Plate Detector for Neutrons," Physica B, Vol. 213/214, pp. 975-977, 1995.
98. Karasawa, Y., Niimura, N., Tanaka, I., Miyahara, J., Takahashi, K., Saito, H., Tsuruno, A. and Matsubayashi, M., "An Imaging Plate Neutron Detector," Physica B, Vol. 213/214, pp. 978-981, 1995.
99. Stade, J., Kaling, M. and Rant, J.J., "Investigation of Imaging Plates as Detector for Neutron Radiography," Ref. 8, pp. 298-306, 1996.
100. Johnston, S.C. and Dahlke, L.W., "Transient Gas Density Measurement Using Neutron Radiography," Review of Scientific Instruments, Vol. 49, No. 2, pp. 242-244, 1978.
101. Poeth, D.F., Ruud, C.O. and Levine, S.H., "The Measurement of Neutron Cross Sections for Contrast-Enhancing Penetrant Fluids," Research in Nondestructive Evaluation, Vol. 8, pp. 67-82, 1996.
102. Brenizer, J.S., Hosticka, B., Berger, H. and Gillies, G.T., "The Use of Contrast Agents to Enhance Crack Detection Via Neutron Radiography," NDT&E, Vol. 31, 1998.
103. Edenborough, N.B., "Neutron Radiography to Detect Residual Core in Investment Cast Turbine Airfoils," Ref. 14, pp. 152-157, 1976.
104. Tsukimura, R.R., Underhill, P.E. and Wells, M.J., "Sensitivity of Core Detection in Turbine Blades," Ref. 5, pp. 329-336, 1986.
105. Anon., "Standard Test Method for Neutron Radiographic Dimensional Measurements," ASTM Standard E 1496, American Society for Testing and Materials, West Conshohocken, PA, 1992.

106. Anon., "Standard Method for Determining Image Quality in Direct Thermal Neutron Radiographic Examination," ASTM Standard E 545, American Society for Testing and Materials, West Conshohocken, PA, 1998.
107. Anon., "Industrial Neutron Radiography, Determination of the Speed and Average Contrast of Silver Film Receiving Systems by Means of Electrons with Energy Less Than 200 keV," Standard A-09-213, Association Francaise de Normalisation (AFNOR), Paris, France, 1981.
108. Anon., "Industrial Neutron Radiography, Determination of the Characteristics of Testing Facilities for Non-Radioactive Parts," Standard A-09-220, Association Francaise de Normalisation (AFNOR), Paris, France, 1982.
109. Berger, H. and LaPorte, A., "Discussion on the Workshop on Neutron Radiography Standards for General Industry," Ref. 4, pp. 1013-1016, 1983.
110. Haskins, J., "ASTM Activities in Neutron Radiography," Ref. 14, pp. 106-113, 1976.
111. Haskins, J., "Standards for Neutron Radiography," ASTM STP 624, pp. 108-114, American Society for Testing and Materials, West Conshohocken, PA, 1977.
112. Brenizer, J.S., "Current and Future Neutron Radiologic NDT Standards," Nondestructive Testing Standards – Present and Future, H. Berger and L. Mordfin, Editors, ASTM STP 1151, pp. 34-40, American Society for Testing and Materials, West Conshohocken, PA, 1992.
113. Anon., "ASNT Level III Certification by Examination," Materials Evaluation, Vol. 34, No. 11, pp. 1C-20C, 1976.
114. Anon., "Level III Study Guide – Basic," 96 pages, American Society for Nondestructive Testing, Columbus, OH, 1980.
115. Whittemore, W.L., "Personnel Training and Certification," Ref. 14, pp. 87-92, 1976.
116. Code of Federal Regulations (CFR), Title 10, Chapter 1.
117. Berger, H., Polichar, R. and Rowe, W.J., "Corrosion Detection by Real-Time Neutron Imaging," Ref. 5, pp. 563-570, 1986.
118. Berger, H., "Neutron Radiographic Detection of Corrosion," Corrosion Monitoring in Industrial Plants Using Nondestructive Testing and Electrochemical Methods, C.G. Moran and P. Labine, Editors, ASTM STP 908, pp. 5-16, American Society for Testing and Materials, West Conshohocken, PA, 1992.

119. Froom, D.A., Private communication, McClellan Air Force Base, CA, 1990.
120. Rowe, W.J., Sproat, W.H. and Berger, H., "Corrosion Detection System Design," Report AFWAL-TR-87-4004, Wright-Patterson Air Force Base, OH, 1987.
121. Froom, D.A. and Barton, J.P., "Plans for Aircraft Maintenance Neutron Radiography Systems, Ref. 5, pp. 431-438, 1986.
122. Underhill, P.E. and Newacheck, R.L., "Miscellaneous Applications of Neutron Radiography," Ref. 14, pp. 252-267, 1976.
123. Moravec, J., Army Yuma Proving Ground, Private communication, 1990.
124. Tomlinson, R.L., "Industrial Neutron Radiography in the United States of America," Ref. 15, pp. 291-326, 1977.
125. Ross, A.M., "Detecting Cladding Leaks in Irradiated Fuel Elements by Neutron Radiography," Ref. 14, pp. 195-209, 1976.
126. Berger, H., Lapinski, N.P. and McKee, J.M., "Neutron Radiography of Sodium Cold Traps," Trans. American Nuclear Society, Vol. 17, pp. 164-165, 1973.
127. Berger, H., Parker, W.L., Lapinski, N.P. and Reimann, K.J., "Three-Dimensional Inspection by Thermal Neutron Laminagraphy," Trans. American Nuclear Society, Vol. 22, pp. 156-157, 1976.
128. Moss, R.A. and Kelly, A.J., "Neutron Radiographic Study of Limiting Planar Heat Pipe Performance," International Journal Heat Mass Transfer, Vol. 13, pp. 491-502, 1970.
129. Stewart, P.A.E., "Cold Neutron Imaging for Gas Turbine Inspections," Real-Time Radiologic Imaging: Medical and Industrial Applications, D.A. Garrett and D.A. Bracher, Editors, ASTM STP 716, pp. 180-198, American Society for Testing and Materials, West Conshohocken, PA, 1980.
130. Pullen, D.A.W., "Radiographic Photogrammetry Yields Valuable Data in Studies of Running Gas Turbines," Mechanical Engineering Technology, pp. 27-31, 1981.
131. Jones, J.D., Lindsay, J.T., Kauffman, C.W., Vulpetti, A. and Peters, B.D., "Real-Time Neutron Imaging Applied to Internal Combustion Engine Behavior," SAE Paper 850560, Society of Automotive Engineers, Warrendale, PA, 1985.

132. Brown, M. and Parks, P.B., "Neutron Radiography in Biological Media – Techniques, Observations and Implications," American Journal of Roetgenology, Vol. 106, pp. 472-485, 1969.
133. Boyne, P.J. and Whittemore, W.L., "Delineation of Pathologic Intraosseous Lesions by Neutron Radiographic Imaging," Ref. 5, pp. 513-518, 1986.
134. Matsumoto, G. and Kato, K., "Detection of Mice Cancer by Neutron Radiography," Ref. 8, pp. 703-708, 1996.
135. Rauch, H. and Zeilinger, A., "Hydrogen Transport Studies Using Neutron Radiography," Ref. 15, pp. 249-290, 1977.
136. Nakanishi, T.M., Tsuruno, A. and Matsubayashi, M., "Water Movement in Plant," Ref. 8, pp. 716-719, 1996.
137. Brenizer, J.S., Tobin, K.W., Hylko, J.M., McRae, D.D. and Jenkins, R.W., Jr., "Quantitative Measurement of Equivalent Water Density in a Burning Cigarette," Materials Evaluation, Vol. 45, pp. 1310-1314, 1987.
138. Brenizer, J.S., Jenkins, R.W., McRae, D.D., Paine, J.B. and Sulcoski, M.F., "Temperature Sensitive Contrast Agents for Neutron Radiography," Ref. 5, pp. 813-820, 1986.
139. Brenizer, J.S., Sulcoski, M.F., Tobin, K.W., Jenkins, R.W. and McRae, D.D., "Evaluation of Filter Behavior by Neutron Radiography," Journal of Aerosol Science, Vol. 18, pp. 311-320, 1987.
140. Lewis, J.T. and Krinitzsky, E.L., "Neutron Radiation in the Study of Soil and Rock," Ref. 14, pp. 241-251, 1976.
141. Lopes, R.T., Bessa, A.P., Braz, D. and Jesus, E.F.O., "Neutron Computed Tomography in Compacted Soils," Ref. 8, pp. 734-741, 1996.
142. Rant, J. and Ilic, R., "Neutron Radiography in Metallurgy," Ref. 15, pp. 327-359, 1977.
143. Ghosh, J.K. and Shriwastwa, B.B., "Application of Neutron Induced Alpha Autoradiography for Monitoring Boron Re-Distribution Behaviour in Steels During Welding and Heat Treatment," Ref. 8, pp. 411-416, 1996.
144. Bayon, G., Drevet, B., Ilic, R., Humar, M., Rant, J.J. and Nguyen Thi, H., "Application of Neutron Radiography and Neutron Induced Autoradiography in the Study of Cellular and Dendritic Solidification of Al-Li Alloys," Ref. 8, pp. 417-424, 1996.

145. Hillig, O.R., "Neutron Radiographic Enhancement Using Doping Materials and Neutron Radiography Applied to Museum Art Objects," Ref. 14, pp. 268-276, 1976.
146. Garrett, D.A., "Thermal Neutron Xeroradiography," Dimensions, Vol. 61, No. 3, p. 22, National Bureau of Standards, Washington, D.C., 1977.
147. Fischer, C.O., Laurenze, C., Leuther, W. and Slusallek, K., "Neutron Activation Autoradiography of Paintings by Rembrandt and His Time," Non-destructive Testing – Proceedings of the 4th European Conference on Non-destructive Testing, Vol. 3, pp. 2180-2184, Pergamon Press, London, 1988.
148. Fischer, C.O., Leuther, W., Schmidt, C., Kelch, J., Laurenze, C., Moisa, W., Yaldiz, M. and Slusallek, K., "Autoradiography of Paintings," Ref. 8, pp. 681-687, 1996.
149. Masuzawa, F., Murata, T., Ozaki, M., Yoneda, K., Okamoto, K., Tsujimoto, T., Sato, M., Nagai, Y., Yokoshima, K., Yasuda, A., "Neutron Radiography Application to Ancient Arts (IV)," Ref. 8, pp. 694-701, 1996.
150. Iddings, F., "Miscellaneous Neutron Techniques," Ref. 14, pp. 303-306, 1977.
151. Rowe, J.M., "NIST Center for Neutron Research – Annual Report," Report NIST 6112, National Institute of Standards and Technology, Gaithersburg, MD, 1997.
152. Larsen, W., Federal Aviation Administration, Private communication, June, 1998. FAA Air Agency Certificate No. E25R1540, dated March 24, 1998; issued June 18, 1998.
153. Gibbs, K. M., Berger, H., Jones, T. S, and Davis, M., "Electronic X-Ray Systems for Field Aircraft Inspection", Materials Research Symposium Proceedings, Vol. 503, pp. 63-68, 1998.
154. Antonuk, L. E, "Flat (-Panel) Horizons In Digital X-Ray Imaging", Photonics Spectra, Vol. 29, No. 6, pp. 108-116, 1995.

GLOSSARY for NEUTRON RADIOGRAPHY

Activation—The process of causing a substance to become artificially radioactive by subjecting it to bombardment by neutrons or other particles.

Activation Reaction—Usually neutron capture (n, γ); i.e., absorption of a neutron by the nucleus of an atom followed by release of a gamma ray. See activation.

Autoradiography—A technique for detecting radioactivity in a specimen by producing an image on a photographic film or plate. Also known as radioautography.

Capture Reaction—A process in which an atomic or nuclear system acquires an additional particle; for example, the capture of electrons by positive ions, or capture of neutrons by nuclei.

Cf-252—A man-made element which decays with the emission of neutrons by spontaneous fission (also decays by alpha emission).

Collimation—To render parallel to a certain line or direction; paths of neutrons in a beam, or paths of various rays of a beam are treated in such a manner to cause them to become more nearly parallel as they approach a target.

Contrast Agent—A material added to a specimen to make it more easily detected or seen on a radiograph. Boron or boron compounds may be added to a specimen so that it can more easily be detected by thermal neutrons.

Deuteron—The nucleus of a deuterium atom, consisting of a neutron and a proton. Designated d. Also known as deuton.

Direct Imaging—Neutron radiography performed with the specimen and the converter screen plus film package or imaging device in the neutron beam.

Epicadmium Neutron—A neutron with a kinetic energy above 0.3 electron volt or above the energy level at which cadmium has a large neutron cross section.

Epithermal Neutron—A neutron having a kinetic energy above thermal neutrons (0.026 electron volts), roughly between 0.5 and 100 electron volts.

Fast Neutron—A neutron having kinetic energy greater than some arbitrary lower limit, usually a few thousand electron volts.

Fission—The division of an atomic nucleus into parts of comparable mass; usually restricted to heavier nuclei such as isotopes of uranium, plutonium, and thorium. Also known as atomic fission; nuclear fission.

Half Thickness—The thickness of a sheet of material which reduces the intensity of a beam of radiation passing through it to one-half its initial value. Also known as half-value layer; half-value thickness.

Half Value Layer—See Half Thickness

Indium Resonance Neutrons—Neutrons having kinetic energies above thermal energy that are very likely to be absorbed by indium; neutrons with kinetic energies of around 1.46 electron volts have neutron cross sections in indium above 10,000 barns.

Microscopic Cross Section—Cross section for neutrons in units of area (cm^2) which represents the probability an interaction between a neutron and nucleus of an atom. It is not necessarily the real cross sectional area of the nucleus. See Cross Section.

Moderator—A material used to slow down neutrons. Usually low atomic number materials such as hydrogen, deuterium, beryllium and carbon that have low neutron absorption cross sections.

Moderation—The process of slowing down neutrons usually by a collision process called elastic scatter in which the neutron gives part of its kinetic energy to the nucleus in the collision.

Modulation Transfer Function—The MTF is a method for evaluation of real-time radiography systems; it is the ratio of the image amplitude to the specimen amplitude. The MTF is often represented as a graph of response versus lines/mm for a specimen designed as a pattern of lines or bars.

Neutrography—Neutron radiography

Nuclear Absorption—Absorption of energy or neutrons by the nucleus of an atom.

Nuclear Poison Materials—Materials having very large neutron absorption cross sections which are added to or formed by the fission process in nuclear reactor fuel rods.

Pulsed Nuclear Reactors—Reactors capable of producing a burst or pulse of neutrons, usually by rapid removal of the control rods. A TRIGA reactor can be pulsed.

(d, D) Reaction—A reaction used in ion accelerators to produce high energy (2.5 MeV) neutrons. Deuterium is ionized and accelerated into a target containing deuterium (usually absorbed in metals such as titanium).

(d, T) Reaction—A reaction used by small ion accelerators to produce high energy (14 MeV) neutrons. Deuterium is ionized and accelerated into a target containing tritium (hydrogen with a mass of 3) usually absorbed in titanium.

(n, 2n) Reaction—A nuclear reaction in which a fast neutron collides with a nucleus and caused the ejection of two neutrons.

(n, α) Reaction—A nuclear reaction in which a neutron, usually high energy, is absorbed in a nucleus and an alpha particle is ejected. Boron-10 has a high cross section for this reaction with thermal neutrons.

(n, γ) Reaction—A nuclear reaction in which a neutron, usually thermal energy, is absorbed in a nucleus with the ejection of a gamma ray. This is the reaction often described as thermal neutron capture and is one of the most common nuclear reactions with thermal neutrons.

(n,p) Reaction—A nuclear reaction in which a neutron, often high energy, enters a nucleus and a proton is ejected. Nitrogen-14 undergoes this reaction with thermal neutrons.

Scattered Neutron—Neutrons that have interacted with the nuclei of atoms so that their energy has been reduced and their direction of travel has been changed. Scattered neutrons from a specimen may still contribute to image formation.

Scattering—See Scattered Neutrons and Moderation.

Scintillation Counter—A device in which the scintillations produced in a fluorescent material by an ionizing radiation are detected and counted by a multiplier phototube and associated circuits; used in medical and nuclear research and in prospecting for radioactive ores. Also known as scintillation detector; scintillometer.

Thermal Neutron—Neutrons having energies ranging between 0.005 eV and 0.5 eV; Neutrons of these energies are produced by slowing down fast neutrons until they are in equilibrium with the moderating medium at a temperature near 20°C.

Thermalization—Slowing down of fast neutrons by an appropriate material. See Moderator.

Track Etch Films—Films that detects neutrons by interactions with a screen that converts the neutron into an alpha particle which strikes the film. Upon chemical treatment, the points at which the alpha particles struck the film are changed to a small hole. These films may be used to make neutron radiographic images.

Transfer Imaging—Neutron radiography in which a screen of material that can be activated, such as indium, is placed behind the specimen in the neutron beam. After activation in the neutron beam, the screen is removed from behind the specimen and placed on an appropriate radiographic film where the radioactivity of screen creates an autoradiographic image (after the film is developed).

Xerography—A printing method developed by the Xerox Corporation: a negative image is formed by a resinous powder on an electrically charged plate, and this image is transferred and thermally fixed onto a paper as a positive.