

note technical note technical

Effects of Concentrated Hydrochloric Acid Spills on Aircraft Aluminum Skin

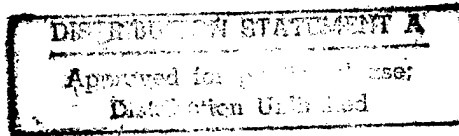

Louise C. Speitel

July 1998

DOT/FAA/AR-TN97/108

This document is available to the public through the National Technical Information Service (NTIS), Springfield, Virginia 22161



U.S. Department of Transportation
Federal Aviation Administration

19981026 059

NOTICE

This document is disseminated under the sponsorship of the U.S. Department of Transportation in the interest of information exchange. The United States Government assumes no liability for the contents or use thereof. The United States Government does not endorse products or manufacturers. Trade or manufacturer's names appear herein solely because they are considered essential to the objective of this report.

1. Report No. DOT/FAA/AR-TN97/108		2. Government Accession No.		3. Recipient's Catalog No.	
4. Title and Subtitle EFFECTS OF CONCENTRATED HYDROCHLORIC ACID SPILLS ON AIRCRAFT ALUMINUM SKIN				5. Report Date July 1998	
				6. Performing Organization Code AAR-422	
7. Author(s) Louise C. Speitel				8. Performing Organization Report No. DOT/FAA/AR-TN97/108	
9. Performing Organization Name and Address Fire Safety Section William J. Hughes Technical Center Atlantic City International Airport, NJ 08405				10. Work Unit No. (TRAIS)	
				11. Contract or Grant No.	
12. Sponsoring Agency Name and Address U.S. Department of Transportation Federal Aviation Administration Office of Aviation Research Washington, DC 20591				13. Type of Report and Period Covered Technical Note	
				14. Sponsoring Agency Code	
15. Supplementary Notes					
16. Abstract This document describes the tests conducted to evaluate the effects of a spill of a strong corrosive acid such as hydrochloric acid (HCl) on aircraft interior skin and to determine the time required for a spill of Department of Transportation (DOT) allowable volumes and concentrations to cause catastrophic failure. Test data indicate that the epoxy coated interior aluminum skin is resistant to acid attack. The acid reacted vigorously with scratched skin surfaces, creating a wide hole in the skin along the scratch line. Test data also indicate that a spill of concentrated HCl can eat completely through the rivets and ribs and may result in a significant loss of structural rib strength.					
17. Key Words Hydrochloric acid, Acid spill, Aircraft skin, Aircraft			18. Distribution Statement This document is available to the public through the National Technical Information Service (NTIS), Springfield, Virginia 22161.		
19. Security Classif. (of this report) Unclassified		20. Security Classif. (of this page) Unclassified		21. No. of Pages 13	22. Price

TABLE OF CONTENTS

	Page
1. INTRODUCTION	1
1.1 Objectives	1
1.2 Background	1
1.3 Test Materials	1
2. DESCRIPTION OF TESTS AND RESULTS	1
2.1 Test Methods	1
2.1.1 Test 1	2
2.1.2 Test 2	2
2.1.3 Test 3	5
2.1.4 Test 4	6
2.2 Observations	7
3. SUMMARY OF RESULTS	8
4. REFERENCE	8

LIST OF ILLUSTRATIONS

Figure		Page
1	Test Article for Test 1: 3- by 3-Foot Sidewall of a Boeing 747	3
2	Test 1 in Progress With a 1-Liter Spill of Concentrated Hydrochloric Acid	3
3	Test Article for Test 2 After Removal From Pyrex Pan Containing 1 Liter of Concentrated Hydrochloric Acid, Two Views	4
4	Test Article for Test 3 Prior to Acid Spill	5
5	Test 3 in Progress With a 1-Liter Spill of Concentrated Hydrochloric Acid	5
6	Test Article for Test 3 After a 90-Minute Contact With Spilled Concentrated Hydrochloric Acid. Top of Test Container Removed.	6
7	Test Article for Test 4. Scratched B-747 Skin After Removal From Pyrex Pan Containing 1 Liter of Concentrated Hydrochloric Acid.	6

LIST OF TABLES

Table		Page
1	Description of Test Articles for Acid Spill Tests	2
2	Summary of Observations for Acid Spill Tests	7

1. INTRODUCTION.

1.1 OBJECTIVES.

The purpose of this study is to evaluate the effect of a spill of concentrated hydrochloric acid (HCl) on the aircraft aluminum skin of a cargo compartment and to determine the time required for a spill to cause catastrophic failure for a worst-case scenario.

1.2 BACKGROUND.

The maximum volume of concentrated HCl currently allowed on passenger aircraft is 1 liter. At the request of the Research and Special Programs Administration, the Department of Transportation (RSPA DOT), the agency that regulates transport of hazardous materials, the Federal Aviation Administration (FAA) performed acid spill tests to evaluate their effect on the interior surface of the aircraft skin.[1] The work described in this report is in response to this request.

1.3 TEST MATERIALS.

The materials used in this study are listed below:



- Reagent: Concentrated HCl Solution: 36.5%-38.0%
- Skin obtained from a sidewall of a B-747, 1.75 mm thick, white epoxy coating on exterior surfaces, green epoxy coating on interior surfaces
- metal tongs
- epoxy paint
- silicone caulk
- Hi 8 Video camera
- 35-mm still camera

2. DESCRIPTION OF TESTS AND RESULTS.

2.1 TEST METHODS.

Four spill tests with concentrated HCl onto various size sections of a Boeing 747 aircraft skin were conducted. The test configurations are listed in table 1. Epoxy paint was used to coat all the cut or scraped surfaces as well as any additional aluminum surfaces used in the fabrication of the container materials in tests 2 and 3. Silicone caulk was used in test 3 to seal the test specimen in the exposure container. Video and photographic coverage were used with each test.

TABLE 1. DESCRIPTION OF TEST ARTICLES FOR ACID SPILL TESTS

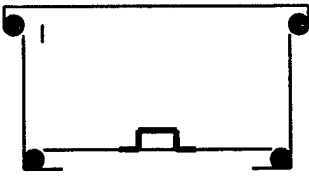
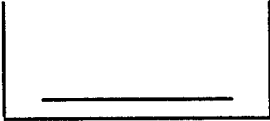
Test No.	Drawing	Test Article Description	Vol. HCl (liters)	Maximum Depth of Acid (inches)
1		3' x 3' section of fuselage	1.0	1/4
2		6" x 6" section of aluminum skin in a 7" x 7" Pyrex pan	1.0	1 1/4
3		7" x 7" section of aluminum skin as base of pressurized box, 0-2.5 psi. Silicone caulk used as a seal.	1.0	1 1/4
4		One scratched strip of aluminum skin, 2" x 6 3/4" in a 7" x 7" Pyrex pan	1.0	1 1/4

2.1.1 Test 1.

The first test was the largest, a 3- by 3-foot section with a 1-liter acid spill (figures 1 and 2). The edges of the skin were bent upwards to contain the acid. In the process of bending the skin and cutting notches in the ribs to allow the bending of the frame, scrapes and breaks in the surface coating of the aluminum skin were produced. There was no treatment of the marred surfaces in this test. The acid contacted not only the interior skin surface but also the bulkhead plates and fittings and the ribs and attaching grommets.

2.1.2 Test 2.

A 6- by 6-inch section of the skin, including the frame material, was placed in a Pyrex pan with the outside surface of the skin face down. All cut edges of the test sample were covered with epoxy paint. One liter of concentrated HCl was spilled into the Pyrex pan. The depth of acid was 1 1/4 inches. Periodically the section of skin was lifted out of the solution with metal tongs to visually evaluate the damage as a function of exposure time. The test specimen was rinsed with tap water at the conclusion of the test and photographed (figure 3).

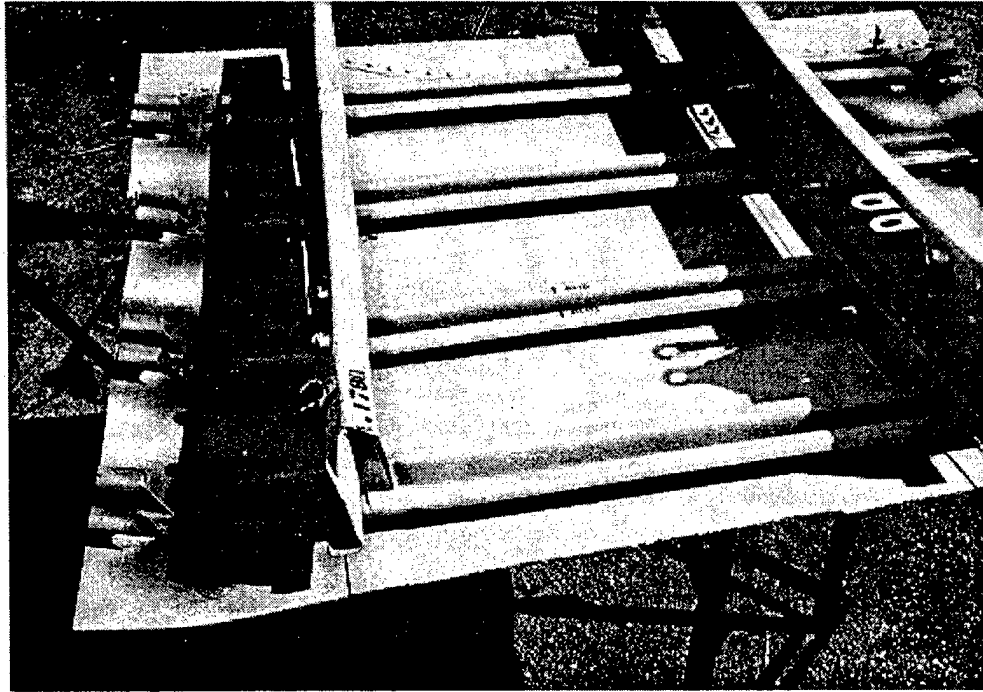

FIGURE 1. TEST ARTICLE FOR TEST 1: 3- BY 3-FOOT SIDEWALL OF A BOEING 747

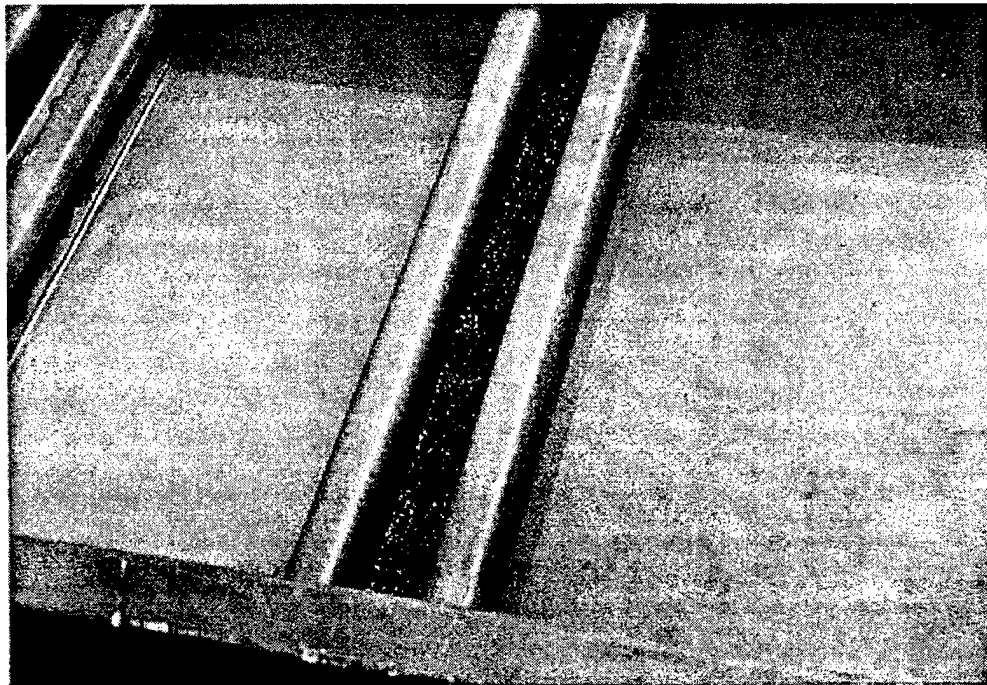
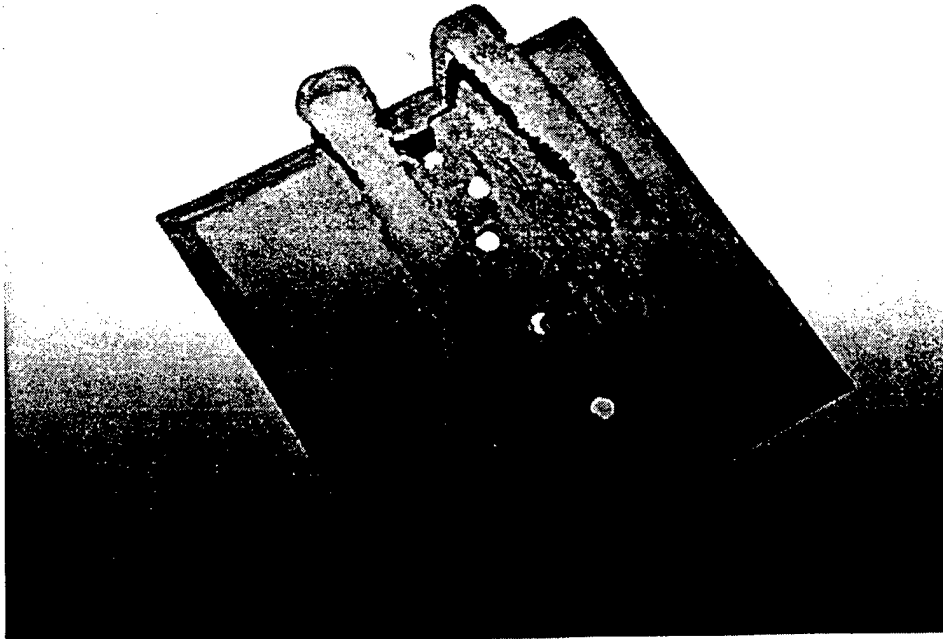
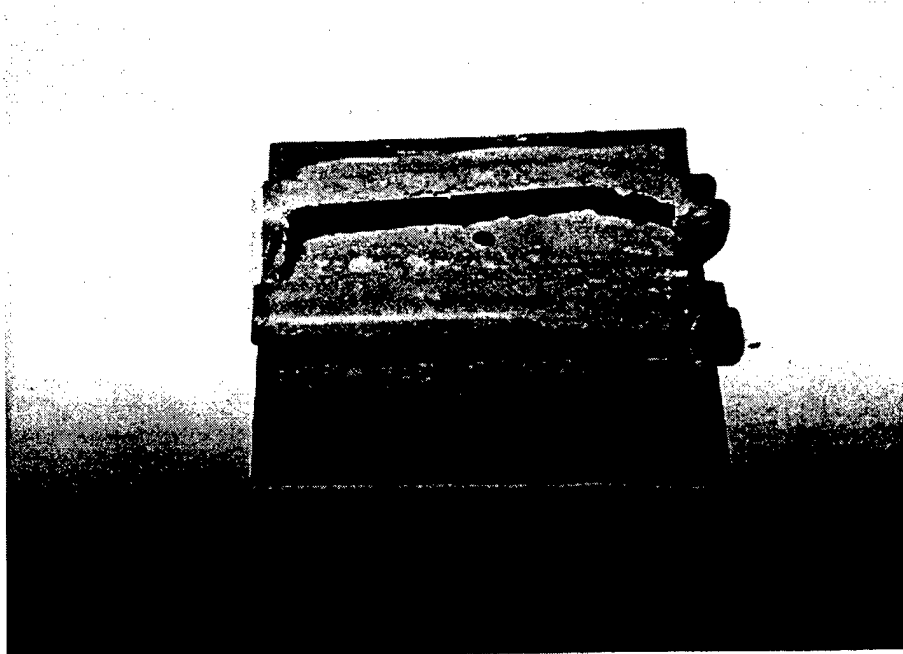

FIGURE 2. TEST 1 IN PROGRESS WITH A 1-LITER SPILL OF CONCENTRATED HYDROCHLORIC ACID



Overhead View



Side View

**FIGURE 3. TEST ARTICLE FOR TEST 2 AFTER REMOVAL FROM PYREX PAN
CONTAINING 1 LITER OF CONCENTRATED HYDROCHLORIC ACID, TWO VIEWS**

2.1.3 Test 3.

A 7- by 7-inch section of aluminum skin was used as the base of a box (figures 4, 5, and 6). All cut edges of the test sample were covered with epoxy paint. The test specimen was caulked to the bottom of a shallow aluminum box with silicone caulk. The bottom of the box was cut out to be slightly smaller than the test specimen resulting in a high-contact surface of the silicone caulk with both surfaces. An epoxy coated metal lid was caulked in place over the aluminum box. The lid contained two Teflon swagelok bulkhead unions. The box was pressurized with nitrogen from 0 to 2.5 psi.

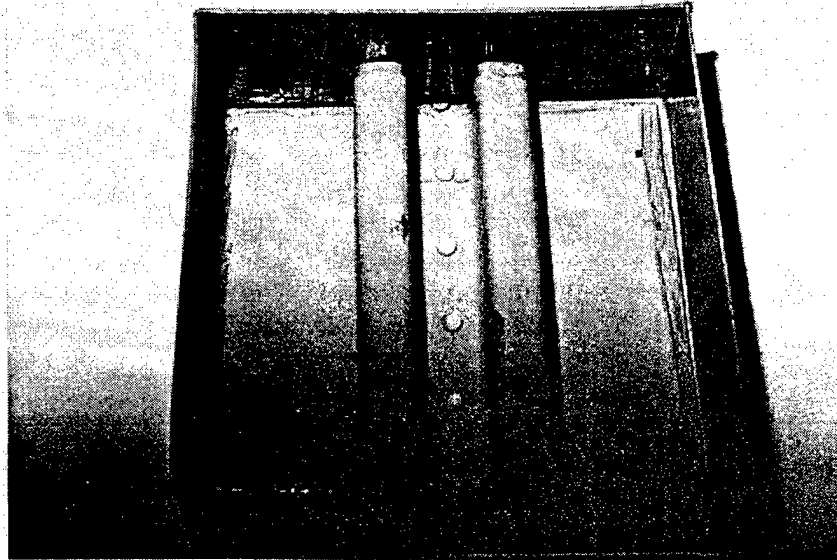

FIGURE 4. TEST ARTICLE FOR TEST 3 PRIOR TO ACID SPILL

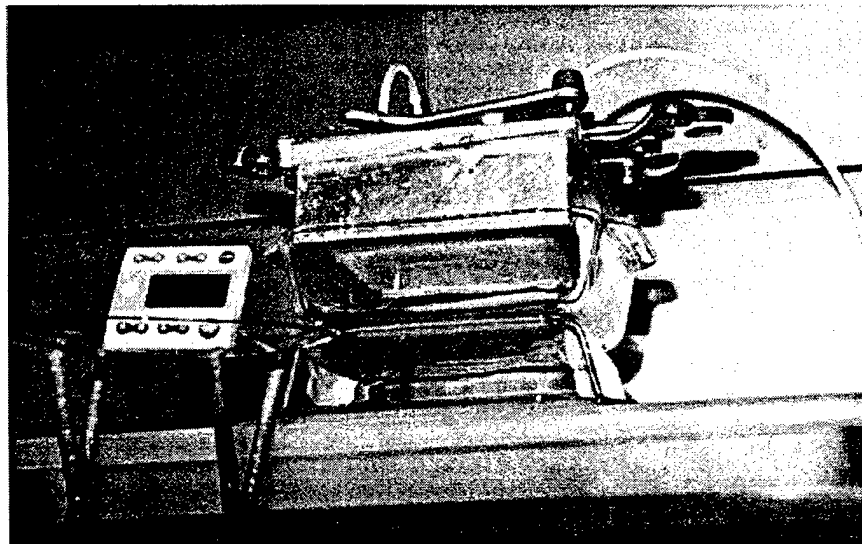

FIGURE 5. TEST 3 IN PROGRESS WITH A 1-LITER SPILL OF CONCENTRATED HYDROCHLORIC ACID

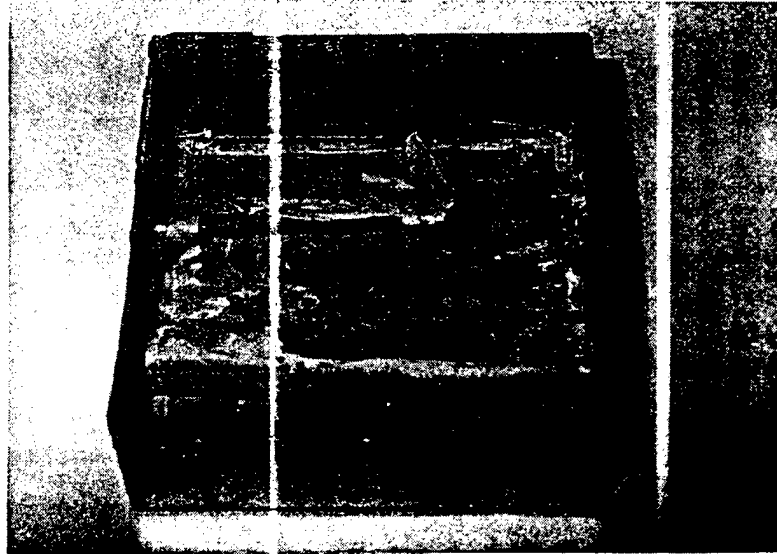

FIGURE 6. TEST ARTICLE FOR TEST 3 AFTER A 90-MINUTE CONTACT WITH SPILLED CONCENTRATED HYDROCHLORIC ACID. TOP OF TEST CONTAINER REMOVED.

A 2.5 psi box pressure simulates the ΔP_{skin} at 15,000 feet altitude. A small ΔP may result in the blowout of the white exterior epoxy paint on the bottom of the box when the rivets fail, giving a visual indication of failure. However, the silicone lid seal failed early into the test and pressure fell to ambient.

One liter of concentrated HCl was poured into the test box through a funnel placed in the swagelok fitting. The depth of acid was 1 1/4 inches. The box was maintained initially at 2.5 psi with a nitrogen purge. The purge flow ranged from 0.2 to 2 liters per minute. The intent of the purge was to prevent the buildup of dangerous hydrogen gas, a decomposition product of the reaction of HCl and aluminum. Box pressure was maintained with a needle valve plumbed downstream of the box.

2.1.4 Test 4.

A 2- by 6 3/4-inch piece of aluminum skin was placed, interior side up, in a 7- by 7-inch Pyrex pan. Two scratches were made on the top green epoxy surface. One liter of concentrated HCl was placed in the pan. The specimen was rinsed with water at the conclusion of the test and photographed (figure 7).

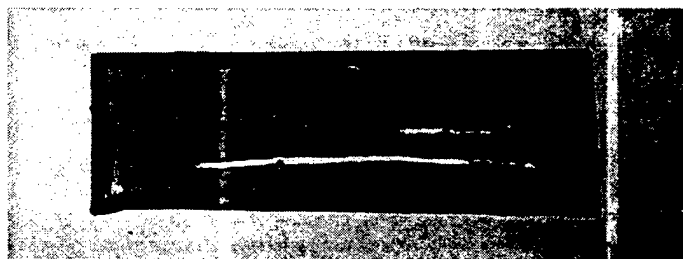

FIGURE 7. TEST ARTICLE FOR TEST 4. SCRATCHED B-747 SKIN AFTER REMOVAL FROM PYREX PAN CONTAINING 1 LITER OF CONCENTRATED HYDROCHLORIC ACID.

2.2 OBSERVATIONS.

Observations of the acid spill tests are listed in table 2.

TABLE 2. SUMMARY OF OBSERVATIONS FOR ACID SPILL TESTS

Test No.	Test Article Description	Location of Failure	Time to Failure (min.)	Comments	Figure No.
1	3' x 3' section of fuselage	At scratched surfaces and at bends in skin	47, 65, and 80	Acid created hole in skin at scratched and bent surfaces.	1, 2
		At rivets	No failure	Rivets partially decomposed, but still intact.	
2	6" x 6" section of aluminum skin in a 7" x 7" Pyrex pan	At rivets	50	Three rivets eaten away below surface of skin.	3
		At ribs	70	Side of rib eaten 1/2 inch through the length of rib. Severe corrosion.	
			80	All submerged surfaces of unpainted rib completely gone.	
		At rivets	85	Only white exterior paint remained where rivets were.	
3	7" x 7" section of aluminum skin as base of pressurized box, 0-2.5 psi. Silicone caulk used as a seal.	At rivets	N/A	Severe corrosion. Rivets eaten through below surface of the skin.	4, 5, 6
		At ribs	90	Rib disconnected from aluminum skin. All submerged surfaces of unpainted rib completely gone. Base seal remained intact. Pressure not maintained during the test due to failure of lid seal.	
4	One scratched strip of aluminum skin, 2" x 6 3/4" in a 7" x 7" Pyrex pan	At scratches	60-90	Acid created hole through the aluminum skin along the scratch. The white exterior epoxy paint was wrinkled, but the seal remained intact.	7

3. SUMMARY OF RESULTS.

- a. The ribs of the cutout sections of a Boeing 747 lost all structural strength after less than a 90-minute immersion in concentrated HCl.
- b. Test data indicate that a spill of concentrated HCl can eat completely through the rivets.
- c. Scratches through the protective green epoxy coating of the interior fuselage skin form a reactive surface. An acid spill onto such a surface was found to react vigorously with the metal, leaving behind a large hole through the aluminum skin along the scratch.

4. REFERENCE.

1. Spencer Watson, DOT/RSPA, personal communication.