

002059

JPRS-UEN-84-034

19 November 1984

USSR Report

ENERGY

19981023 124

DTIC QUALITY INSPECTED 2

FBIS

FOREIGN BROADCAST INFORMATION SERVICE

Reproduced From
Best Available Copy

15
111
A06

NOTE

JPRS publications contain information primarily from foreign newspapers, periodicals and books, but also from news agency transmissions and broadcasts. Materials from foreign-language sources are translated; those from English-language sources are transcribed or reprinted, with the original phrasing and other characteristics retained.

Headlines, editorial reports, and material enclosed in brackets [] are supplied by JPRS. Processing indicators such as [Text] or [Excerpt] in the first line of each item, or following the last line of a brief, indicate how the original information was processed. Where no processing indicator is given, the information was summarized or extracted.

Unfamiliar names rendered phonetically or transliterated are enclosed in parentheses. Words or names preceded by a question mark and enclosed in parentheses were not clear in the original but have been supplied as appropriate in context. Other unattributed parenthetical notes within the body of an item originate with the source. Times within items are as given by source.

The contents of this publication in no way represent the policies, views or attitudes of the U.S. Government.

PROCUREMENT OF PUBLICATIONS

JPRS publications may be ordered from the National Technical Information Service (NTIS), Springfield, Virginia 22161. In ordering, it is recommended that the JPRS number, title, date and author, if applicable, of publication be cited.

Current JPRS publications are announced in Government Reports Announcements issued semimonthly by the NTIS, and are listed in the Monthly Catalog of U.S. Government Publications issued by the Superintendent of Documents, U.S. Government Printing Office, Washington, D.C. 20402.

Correspondence pertaining to matters other than procurement may be addressed to Joint Publications Research Service, 1000 North Glebe Road, Arlington, Virginia 22201.

Soviet books and journal articles displaying a copyright notice are reproduced and sold by NTIS with permission of the copyright agency of the Soviet Union. Permission for further reproduction must be obtained from copyright owner.

19 November 1984

USSR REPORT

ENERGY

CONTENTS

FUELS

OIL AND GAS

Gas Industry's Oldest Design Unit Singled Out for Praise (Editorial; GAZOVAYA PROMYSHLENNOST', No 6, Jun 84)	1
Gas-Industry Design Institute Recounts Chief Feats (N. G. Portyanko; GAZOVAYA PROMYSHLENNOST', No 6, Jun 84)	3
New Element Devised for Centrifugal Gas-Liquid Separation (R. V. Kapitonov, et al.; GAZOVAYA PROMYSHLENNOST', No 6, Jun 84)	7
Centrifugal Rotary Gas-Scrubbing Unit Developed (K. I. Klimov, et al.; GAZOVAYA PROMYSHLENNOST', No 6, Jun 84)	11
Sulfur-Free Gas Supply Found for New Astrakhan Gas Refinery (O. I. Serebryakov, V. A. Grigorov; GAZOVAYA PROMYSHLENNOST', No 6, Jun 84)	14
Gypsum at Orenburg, Astrakhan, Yakutia Mised Geologists (I. S. Gutman, V. Ye. Kopylov; GAZOVAYA PROMYSHLENNOST', No 6, Jun 84)	16
Gathering System at Bakhar Offshore Field Reformed (R. I. Asadov; GAZOVAYA PROMYSHLENNOST', No 6, Jun 84)	19
Science Council Plans To Master Continental-Shelf Oil (V. P. Podkovyrin; GAZOVAYA PROMYSHLENNOST', No 6, Jun 84)	23
New Mud Pump Manifold System Tested, Discussed (V. Minenkov; NEFTYANIK, No 7, Jul 84)	25

Orenburgneft' Efficiency, Economy Measures Discussed (A. Genze, B. Danilov; NEFTYANIK, No 7, Jul 84)	27
Yakutiya Tests High-Molecular Flocculant (Ye. Konovalov, et al.; NEFTYANIK, No 7, Jul 84)	30
Orenburgneft' Association Operations Discussed (R. Khramov; NEFTYANIK, No 7, Jul 84)	33
Caspian Neftyaneye Kamni Field Review and Update (L. Tairov; PRAVDA, 3 Aug 84)	36
Caspian Experience Speeds Present-Day Construction (Kurban Abasovich Abasov Interview; IZVESTIYA, 25 Jul 84)	38

COAL

Laggards, Leaders in Donbass Coal Mining Described (N. Ladanovskiy; PRAVDA UKRAINY, 18 Jul 84)	40
Further Development of Donbass Mines Urged (A. Dokukin; TRUD, 10 Jun 84)	43
Completion of Concentration Mill in Yakutia Expected (M. Morozov; SOVETSKAYA ROSSIYA, 25 Jul 84)	46
Development of New, Powerful Excavator Described (LENINGRADSKAYA PRAVDA, 3 Jul 84)	48
Ways for Lowering Ash Content of Coal Presented (S. Ya. Petrenko, et al.; UGOL', No 7, Jul 84)	49
Improvements in Labor Discipline in Karagandaugol' Described (N. A. Drizhd; UGOL', No 7, Jul 84)	56
Plans for Construction of Fuel Complex Repair Base Discussed (V. V. Andreyev; UGOL', No 7, Jul 84)	59
Briefs	
Miners Pledge Million Tons	62
Katek's Resources, Future Described	62
First Yakut Coal Mine	62
Above Plan Near Moscow	62
Above Plan Near Urals	63
Million-Tonners on the Don	63
Above Plan in Krasnodon	63
Kuzbass Coal Pipeline Growing	64
'Thin-Bed' Mining	64
Above Plan in Vorkuta	64
Stakhanovites in Ekibastuz	64

Geothermal Power in Transcarpathia	65
Above Plan in Krasnoyarsk	65
Above Plan in Turkmenistan	65
New Working Face Complexes	66

ELECTRIC POWER

NUCLEAR POWER

News From Atom mash (SOTSIALISTICHESKAYA INDUSTRIYA, various dates)	67
Completion of Fourth Building Second and Third Steam Generators Improvements of Deliveries to Atom mash Important Construction Reserve Cited Socialist Pledges Fulfilled Construction Responsibility Completion of Annual Plan Role of Foremen in Production Winners of Socialist Competition	

NON NUCLEAR POWER

Turbine Rotor Crack Causes Power Station Fire (D. Melikov; SOTSIALISTICHESKAYA INDUSTRIYA, 19 Oct 84) ...	73
--	----

PIPELINES

PIPELINE CONSTRUCTION

Better Ways of Erecting Large-Diameter Pipelines Described (O. M. Ivantsov; STROITEL'STVO TRUBOPROVODOV, No 6, Jun 84)	74
Automatic Pipeline Welding, Manual Welding Methods Compared (M. Z. Sheynkin; STROITEL'STVO TRUBOPROVODOV, No 6, Jun 84)	83
Way To Find Strength of On-Site Plastic Pipelines Devised (Yu. D. Ovsyannikov, N. G. Novichenko; STROITEL'STVO TRUBOPROVODOV, No 6, Jun 84)	88
Work of Petroleum Scientific-Technical Societies Reviewed (STROITEL'STVO TRUBOPROVODOV, No 6, Jun 84)	94
Precautions in Laying Multiple-Layer Pipe Recommended (Ye. A. Anikin; STROITEL'STVO TRUBOPROVODOV, No 6, Jun 84).	97
Earthmoving for Large-Pipeline Construction Discussed (V. P. Mentjukov, et al.; STROITEL'STVO TRUBOPROVODOV, No 6, Jun 84)	103

OIL AND GAS

GAS INDUSTRY'S OLDEST DESIGN UNIT SINGLED OUT FOR PRAISE

Moscow GAZOVAYA PROMYSHLENNOST' in Russian No 6, Jun 84 p 1

[Editorial: "At the Leading Edge of Design Work"]

[Text] One of the decisive requirements for the Soviet economy's progress along the energy-saving and intensive path of development is realization of the USSR Energy Program. The gas industry, whose boosted pace of development is occurring through the conquest of new gas and gas condensate fields, the construction of high-capacity gas-transporting systems and development of the infrastructure in newly conquered regions, has an important role in this matter of nationwide concern. The complicated climatic and physical-geography conditions under which the new gas complexes are sited are placing higher demands on the quality and reliability of the facilities being erected, especially in areas where the rock has been frozen for many years.

In the work to build USSR Unified Gas-Supply System enterprises, special responsibility has been vested in the designers for the technical level and quality of the engineering solutions.

In solving step-by-step the problems of developing new fields, the industry's design organizations, in creative collaboration with scientific-research institutes, are working out and introducing engineering solutions that call for the use of advanced technology, new highly productive box-module equipment and modern systems of automation and remote control.

Experience in engineering surveys and scientifically substantiated analyses and in the construction of gas complexes in West Siberia and Orenburg Oblast, which has been validated for reliability over many years of operation, has become the basis for developing new and more effective designs, which provide savings of materials--raw and otherwise--and labor resources that are higher than those realized from previously implemented engineering solutions.

A result of the successful development of the design business is the increasingly wide use of highly efficient operating equipment and progressive constructional and layout solutions. Among them are highly productive automated box-module installations for integrated gas treatment and dust traps, gas

repumping units of high unit capacity in basementfree models with full-head injectors, pile footings under the GPA's [gas pumping units], the A-705-15 type automated system, which is founded upon a modern element base, small-scale installations for processing gas condensate, and so on.

The industry's institutes have developed unified technical solutions for KS's [compressor stations] with new GPA's, which call for uniform master plans and sets of structures and the provisioning of a high level of industrialization of construction.

The gas industry's oldest organization--YuzhNIIGiprogaz [State Scientific-Research and Design Institute for the Design of Gas-Industry Installations in the Southern Economic Region]--is rightly in charge of the front rank of the industry's designers. For the 50 years of its existence the institute has worked out hundreds of designs for the country's most important construction projects. The facilities of the Medvezhye field were built up and large gas facilities erected in accordance with them. YuzhNIIGiprogaz played the role of prime designer for the Orenburg gas-chemicals complex.

The institute's collective has undertaken to solve complicated problems during the five-year plan. The facilities buildup of the Yamburg field, the construction of high-powered gas-transporting systems for delivering Yamburg's gas to the Central Economic Region and the country's western regions, and the erection of the Astrakhan complex for recovering and treating highly sulfurous gas--this is a far from complete list of facilities for which the institute is to issue design and budget-estimating papers in the near future.

The leading section of this issue of the journal will acquaint readers with concrete affairs of the YuzhNIIGiprogaz collective and will tell about its contribution in fulfilling the country's Energy Program.

COPYRIGHT: Izdatel'stvo "Nedra" "Gazovaya promyshlennost'", 1984

11409

CSO: 1822/360

OIL AND GAS

GAS-INDUSTRY DESIGN INSTITUTE RECOUNTS CHIEF FEATS

Moscow GAZOVAYA PROMYSHLENNOST' in Russian No 6, Jun 84 pp 2-3

[Article by N. G. Portyanko, Director of YuzhNIIgiprogaz [State Scientific-Research and Design Institute for the Design of Gas-Industry Facilities in the Southern Economic Region]: "50 Years of YuzhNIIgiprogaz"]

[Text] During the 50-year history of the institute's existence, its collective has always aimed at solving the most important problems of the national economy--from equipping cities and settlements for the use of gas during the first five-year plans to participation in establishment of the most huge USSR Unified Gas-Supply System.

The first job of the Proyektgaz Office, which was established on 2 December 1983 [as published] under the Urban Section for Municipal Services, from which the institute got its start, was "The Preliminary Design for Equipping the City of Stalino with Gas, with Connections for 500 Apartments." It was carried out, and on 7 November 1935 purified coking gas arrived at the first apartments.

In the following prewar years the office, which then was Donyuzhgas, did work on the supplying of gas to other Donbass cities and on the building of inter-city pipelines for coking gas and gas filling stations for refueling gas-tank equipped automotive vehicles with coking gas.

At the end of the 1930's, the institute, still Donyuzhgas, was charged with designing underground stations for coal gasification (PGU's). These facilities, in Angren and Yuzhnyy Abinsk, are still operating.

Experience in the design and operation of the PGU stations has interested the USA, which in 1975 bought a license for the production method and technical papers for the design.

During 1946-1955 the institute designed a large number of huge gas-generating stations (the Lisichanskaya, Novokemerovskaya, Novomoskovskaya and others) for chemical combines and machinebuilding and other plants.

At the start of the 1960's, YuzhNIIgiprogaz, as the prime organization, was developing designs for supplying gas to the most huge ferrous and nonferrous

metallurgy and chemical-industry enterprises and was also designing 34 automated cluster bases for liquefied gas that are still operating.

During the same period, YuzhNIIgiprogaz undertook to design facilities for the recovery, treatment and trunk transport of natural gas.

The discovery of gas fields in Yakutia posed YuzhNIIgiprogaz with the task of developing during 1960-1965, for the first time in world experience, a design for the facilities buildup of the Ust'-Vilyuysk gas field and for a gas pipeline in a permafrost environment.

Experience in designing the Yakutsk gas line was later used by the industry's science in, for example, the design and construction of the Messoyakh-Norilsk gas pipeline, which served as a basis for improving hydraulic, heating and other technological analyses during the design of facilities for West Siberia's gas industry.

YuzhNIIgiprogaz, which by the middle 1960's now had at its disposal experience in designing facilities for the North's environment, was charged with creating a design for the facilities buildup for the Medvezhyye gas field and for the first huge West Siberian gas pipelines of 1,200 mm diameter. A feature of the design for the facilities buildup of the Medvezhyye gas field was the use of huge modular UKPG's [integrated gas-treatment installations] with productivities of 10-15 billion m³ of gas per year, which were designed to be built at the factory, with a minimal amount of work in assembling the finished modules to be done at the site.

Along with solving tasks for developing the West Siberian TPK [Regional Production Complex], the 24th and 25th CPSU Congresses defined the facilities of Orenburg as most important national-economic construction projects. YuzhNIIgiprogaz became the prime designer for the Orenburg gas complex.

The innovativeness and originality of the engineering solutions for the complex enable VPO Orenburggazprom [All-Union Orenburg Gas-Industry Production Association] to achieve the industry's highest labor productivity and the country's lowest prime costs for producing sulfur.

During this same period YuzhNIIgiprogaz also was the prime designer for most important and complicated systems for arterial gas transport erected from 1,400-mm diameter pipelines, which are based upon 7.5 MPa of pressure and are equipped with GPA's with unit powers of 10 and 16 MW.

All the main gas pipelines of the 9th and 10th Five-Year Plans, from West Siberian regions to the Urals and to the country's Central Economic Region, were built according to institute designs, which were worked out in collaboration with Mingazprom [Ministry of Gas Industry] institutes.

Designs for the Urengoy-Nizhnyaya Tura-Petrovsk and Urengoy-Petrovsk-Novoposkov trunk pipelines, which were supposed to be built and introduced at the start of the 11th Five-Year Plan, were developed simultaneously and jointly with VNIPItransgaz [All-Union Scientific-Research and Design Institute for the Design of Natural Gas Transport], Soyuzgazproyekt, Giprospekgaz [State Institute

for the Design of Trunk Pipelines and Special Construction of the USSR Ministry of Gas Industry] and Giprogaztsentr [State Institute for the Design of Gas-Industry Facilities for the Central Economic Region].

In order to achieve the highest effectiveness in transporting gas, YuzhNIIgiprogaz, in collaboration with the AN USSR [Ukrainian SSR Academy of Sciences], for the first time developed and introduced an integrated program for optimizing technological schemes for transporting gas on the basis of computer-assisted mathematical methods. This method is now being used widely in the gas industry in the design of trunk gas pipelines.

Six trunk gas pipelines from West Siberia to the country's Central Economic Region, including the specially built Urengoy-Pomary-Uzhgorod gas pipeline, are the leading construction projects of the 11th Five-Year Plan.

The YuzhNIIgiprogaz collective was the prime designers for all these gas pipelines, which stretch for about 20,000 km, and involve more than 20 billion rubles in capital investment for construction.

Along with determining the basic principles of and executing overall supervision over development of the sets of designs, in the preparation of which tens of institutes of Mingazprom and other agencies participated, YuzhNIIgiprogaz did design and survey work directly on the most complicated and important terminal segment of gas pipelines from the Urengoy field to the Urals.

The high state of organization and responsiveness of the institute's collective was manifested especially brightly when the USA's administration embargoed the delivery of gas-pumping equipment for Urengoy-Pomary-Uzhgorod gas-pipeline compressor stations.

The institute, in the shortest of times, developed drawings for different variants for supplying domestic and imported machinery, which completely dissipated the threat of stoppage of the construction project because of a lack of design papers.

The institute's designers are now developing engineering documentation for building gas-industry facilities for the 12th Five-Year Plan.

As prime designer for the facilities buildup of the Yamburg gas field, YuzhNIIgiprogaz is calling for the use of UKPG's of higher productivity and for the placement of the equipment on mobile pontoon-modules.

YuzhNIIgiprogaz also has been named prime designer for the Astrakhan gas complex. Retaining in the design the succession of optimal solutions for erecting the Orenburg gas complex, the institute envisions an increase in the output of commodity output, primarily of sulfur, gasoline, diesel fuel and mazut.

The institute's staff workers are constantly performing designers' surveillance over construction of the facilities it has designed, with trips to the line and to the construction sites by designers' brigades under the supervision of the more highly qualified specialists.

A third USSR State Prize and USSR Council of Ministers prizes have been awarded for the creation of key gas-industry facilities in which YuzhNIIgiprogaz and its workers had played a leading role.

Three times the challenge Red Banner of the USSR Council of Ministers and the AUCCTU and 22 times the challenge Red Banner of the Ministry of Gas Industry and the Central Committee of the Trade Union of Oil and Gas Industry Workers have been awarded to the institute's collective for the results of All-Union socialist competition among the industry's organizations and enterprises.

The Honorary Certificate of the AUCCTU Central Committee for High Labor Achievements was awarded to YuzhNIIgiprogaz in 1981 for great work in the communist indoctrination of youth and for getting youth's participation in accelerating scientific and technical progress. Hundreds of the institute's workers (more than 350) have been awarded USSR orders and medals.

Many of them have been awarded CEMA's Commemorative Medal for Construction of the Soyuz Gas Pipeline. The contribution of the institute's collective in the matter of strengthening the Peace Fund was marked by award of the "Fighter for Peace" medal of the Soviet Committee for the Protection of Peace.

For successes achieved in developing designs for mastering large gas fields and trunk pipelines, YuzhNIIgiprogaz was awarded the Order of Labor Red Banner in 1983.

The YuzhNIIgiprogaz collective is successfully continuing to solve the tasks set for it in a highly qualified and responsive manner and is striving to make a meaningful contribution to development of the country's national economy.

COPYRIGHT: Izdatel'stvo "Nedra" "Gazovaya promyshlennost'", 1984

11409

CSO: 1822/360

OIL AND GAS

UDC 66.074;665.632.074

NEW ELEMENT DEvised FOR CENTRIFUGAL GAS-LIQUID SEPARATION

Moscow GAZOVAYA PROMYSHLENNOST' in Russian No 6, Jun 84 pp 8-9

[Article by R. V. Kapitonov, N. P. Kuznetsova and Yu. A. Lobanov (YuzhNIIGipro-gaz [State Scientific-Research and Design Institute for the Design of Gas-Industry Facilities in the Southern Economic Region]): "A New Separation Element"]

[Text] Research on separation elements has shown that horizontal placement thereof is preferred for purposes of expanding the range of effective operation and eliminating critical states. Strip-type vortex generators possess minimum hydraulic resistance and provide the necessary rate of twist intensity at helix angles of 45-50 degrees.

One of the ways to increase efficiency in scrubbing natural gas of dropping liquid and solid impurities during gas-field treatment and refinery processing is to use the principle of centrifugal separation of gas and liquid impurities. But this principle has not been used widely in the domestic gas industry.

In choosing one structure or another for separating elements, attention must be given to the following basic criteria: high effectiveness of separation for various initial condensate factors; an absence of secondary entrainment; a broad range of change in throughput; minimal hydraulic resistance; simplicity of the constructional scheme; and convenience of installation on existing separation equipment.

The intensity of the rate of twist, optimal ratio of the length and diameter of the separation branch pipe, and average delivery speed affect separating efficiency. Secondary entrainment of the liquid prevents timely removal of the liquid being separated. Maximal throughput of the separation element is determined by the onset of critical states that are marked by transition of the strip mode of flow of the liquid being separated into a strip dispersion mode, which is a function basically of the initial condensate factor, the rate of flow, the direction of motion of the phases, and the length and spatial placement of the separating branch pipe.

The separation element's hydraulic resistance depends primarily upon the design of the vortex generator. Vortex generators that form quasi-solid rotation without zones of reverse currents possess minimal hydraulic resistance.

Convenience of installation is provided by the potential for assembling separation elements in compact modules that can be delivered into the cavity of the separator through the existing opening.

Based upon this, YuzhNIIgiprogaz, jointly with PO Orenburggazzavod [Orenburg Gas Refinery Production Association] has developed centrifugal separation elements that correspond to the criteria indicated above in fuller measure.

The separation element is a cylindrical branch pipe with a vortex generator in the inlet and with a device for removal of the liquid in the form of a ring gap in the outlet part. A steel strip that twists through 360 degrees around its longitudinal axis is used as the vortex generator. This vortex generator practically does not reduce the passageway cross-section of the separation branch pipe, and it forms a swirled stream with quasi-solid rotation without zones of reverse currents.

In order to determine the hydraulic characteristics, separation efficiency and conditions for emergence of critical modes, laboratory research was done on a transparent model of the separation element. During the research, changes were made in the intensity of twisting (length of the twist of the vortex generator), the length of the separation branch pipe, the consumption of the gas-and-liquid mix, the initial content of liquid and gas, and the spatial position of the separation element (from the vertical to the horizontal). The liquid (water) was fed into the air stream by a high-speed sprayer, which created a foglike spray.

Separation efficiency was determined according to the balance of the liquid delivered to the sprayer and that trapped in the separation element.

Research has shown that, with identical intensity of the twist, the hydraulic resistance of the strip vortex generator is much lower than that of a vane swirler, and the separation efficiency and the conditions for appearance of the critical states depend to a great extent upon the spatial positioning of the separation element.

Visual observations of separation-element operation enabled establishment of the following model of the transition to the critical states. Under the vertical arrangement, the gas and liquid mixture was separated in the motion of the phases by direct-flow ascent. Drops of the liquid, on leaving the vortex generator under the effect of centrifugal forces, were separated out on the wall of the separation branch pipe and formed above the vortex generator a spiral-shaped liquid plait. As the ascent proceeds, the film of liquid increases in thickness, disordered waves emerge in it, and, at a definite distance from the vortex generator, the surface of the liquid is broken up by the gas streams, with the forming of bubbles and spray, it being the case that where the original liquid content of the gas is more than $12-15 \text{ cm}^3/\text{m}^3$, transition to the critical state occurs prior to completion of the separation process.

A somewhat different picture is observed with horizontal positioning of the separation element. The liquid to be separated also moves in the form of a spiral-shaped plait, but an appreciable increase in the film's thickness and in wave formation do not occur in this case. The critical states do not appear in the range of change of velocity of flow studied, from 5 to 10 m/sec, and change of the initial liquid content, from 0 to 50 cm³/m³. In this connection the separation effectiveness was studied later with horizontal positioning of the separation element.

The results of the experiments are shown in figure 1. It is evident from the graph that, as the intensity of the twist increases, separation efficiency increases, and maximum efficiency shifts toward lesser speeds. However, when increasing the angle to more than 45 degrees, a reduction in the range of separation-element efficiency is observed. Such a phenomenon is explained by the fact that where $\alpha > 45$ degrees, the intensity of rotation along the length of the separation branch pipe is reduced more rapidly than when $\alpha < 45$ degrees. Therefore, the optimal angle for rise of the twist of the vortex generator is taken as $\beta = 45$ -50 degrees.

Figure 1. Separation Efficiency as a Function of the Velocity of Flow and the Angle of Ascent β of the Vortex Generator Twist.

1. $\beta = 65$ degrees.
2. $\beta = 60$ degrees.
3. $\beta = 50$ degrees.
4. $\beta = 40$ degrees.

- A. Separation effectiveness, percent.
- B. Speed of flow, m/sec.

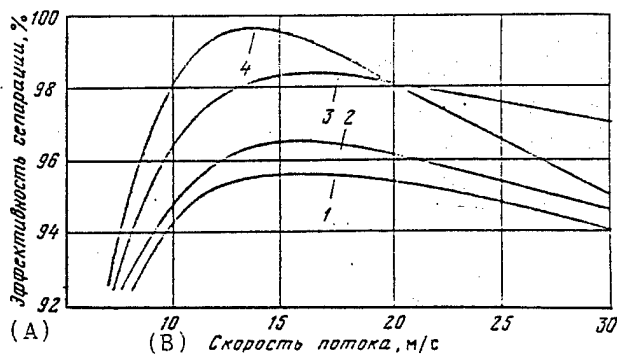

For the indicated angles, the optimal length of the separation branch pipe is 6-8 diameters, and it depends practically not at all upon the velocity of the flow and the initial liquid content of the gas.

Based upon the results obtained, separation-element units have been developed for rebuilding the Orenburg GPZ's separation equipment. The module consists of a cylindrical body 420 mm in diameter and 1,000 mm long with a tube plate in which 29 separation branch pipes with internal diameter of 50 mm have been mounted. Each module has been designed for a nominal throughput of 3 million m³/day at a gas pressure of 6 MPa. The modules were installed in the cavity of the rebuilt separator on special partitions or the existing jalousie frames, or entrainment separators were used.

Figure 2 is a scheme for installing separation modules on the inlet separators of department No 4 of the Orenburg GPZ [Gas Refinery] with a productivity of up to 18 million m³/day. Six modules have been installed on the existing spherical partition and have been supplied with devices for withdrawing the liquid.

Figure 2. Diagram of Separation Modules Installed on the Inlet Separators of Orenburg GPZ [Gas Refinery] Separator Department No. 4.

1. Inlet for gas and liquid.
2. Outlet for the gas.
- 3 and 4. Outlets for the liquid.
5. Centrifugal separation-element modules.
6. Network packing.
7. Device for withdrawing the separated liquid.

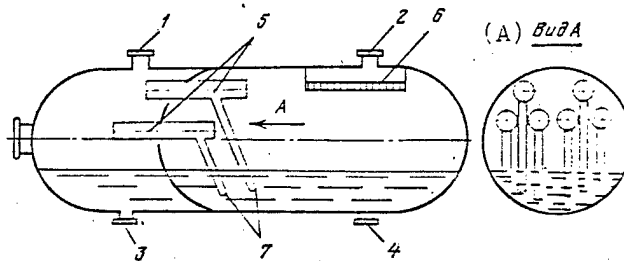

A. View A.

Experimental industrial tests of the separators after reconstruction showed that separation efficiency reached 97.5-99.9 percent where the dropping-liquid content in the raw-material gas was from 0.15 to 8.6 cm³/m³. Entrainment of the liquid with the gas does not exceed 30 cm³/1,000 m³ gas.

The separation-element modules that were developed can be used during rebuilding of various separators at gas-field gas-treatment installations and at gas refineries.

COPYRIGHT: Izdatel'stvo "Nedra" "Gazovaya promyshlennost'", 1984

11409

CSO: 1822/360

CENTRIFUGAL ROTARY GAS-SCRUBBING UNIT DEVELOPED

Moscow GAZOVAYA PROMYSHLENNOST' in Russian No 6, Jun 84 p 10

[Article by K. I. Klimov, D. A. Molodtsov, V. V. Mamistov and G. P. Bosov (YuzhNIIgiprogaz [State Scientific-Research and Design Institute for the Design of Gas-Industry Facilities in the Southern Economic Region] and Shebelinkaprom [Shebelinka Gas-Industry Association]): "Centrifugal Rotary Equipment for Scrubbing Gas"]

[Text] A centrifugal rotary apparatus developed for scrubbing gas finely of liquid and mechanical impurities is of low metal intensiveness, has a highly developed contact surface, is capable of operating with variable gas and liquid loads, and will permit the separation and absorption processes to be combined.

The basis of a new and highly effective device with rotating separation element that YuzhNIIgiprogaz has developed and utilizes the natural gas's energy usefully is improvement of the separator filters. The device is used for scrubbing natural gas of dripping liquid and of mechanical impurities. Moreover, it can be used for separating specific components of various gases.

The rotary design enabled avoidance of such deficiencies as blocking of the filter elements and destruction thereof when hydrates form.

The small dimensions enable it to be manufactured in a modularized and outfitted version, to be used not only on dry land but also at offshore fields and to be delivered more easily to remote areas.

Two types of the apparatus are being manufactured (see the table): I--for treatment of high-pressure gas with rotation of the rotor by the energy of the flow (see figure a); and II--for treatment of low-pressure gas with the rotor rotated by an electric motor (see figure b).

Both types are designed for continuous operation with a rotating frequency of the separating elements on the order of 100 s^{-1} . The rotating frequency can be reduced to 50 s^{-1} as a function of the amount of gas.

The equipment consists of three basic components: the body, the rotor and the bearings. The body can be either of individual fabrication or assembled from

Main Parameters of the Centrifugal Rotary Apparatus

Type of equipment	Pressure (MPa)	Temperature, degrees (C)	Pressure differential (kPa)	Gas consumption (m ³ /hr)	Specific liquid content (cm ³ /m ³)	H ₂ S concentration (g/m ³)	Rpm s ⁻¹	Dimensions (meters)	Weight (kg)
I	2.0-2.2	-10 to -30	30	4,000-8,000	0.4-12	-	100	0.38x0.75x1.15	600
	6.4	-30 to -50	50	10,000-40,000	30-60	-	100	0.72x2.8x3.9	3,700
	3.7	-84	50	160,000-180,000	10 ⁵	-	200	1.4x4.1x3.5	5,300
II	0.02	20 to 50	0.25-1	60-500	-	18-20	100-170	0.3x1.2x0.7	400
	0.02	20 to 50	0.25-0.7	3,000-10,000	-	18-20	50	2.0x2.5x2.5	2,200

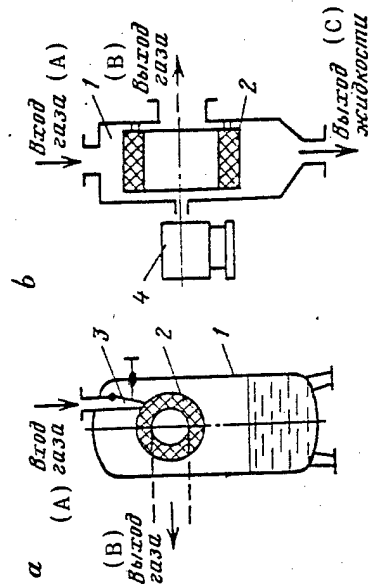

Centrifugal rotary unit with:

- a. gas-powered drive
- b. electric drive
- 1. Body.
- 2. Rotor.
- 3. Nozzle.
- 4. Electric motor.
- A. Gas inlet.
- B. Gas outlet.
- C. Liquid outlet.

standard pipe members. The rotor's design calls for the use of lightweight materials with a developed contact surface. The bearings were chosen as a function of the rotor's rotating frequency and aggressiveness of the medium and its temperature, and can be either rocking or sliding.

Pressure losses in the apparatus with gas-energy rotation of the rotor does not exceed 50 kPa, while with rotation by an electric motor it is from 0.25 to 0.7 kPa. The rotor is connected to the body by a detachable connection, so inspection and replacement of it do not cause difficulties. The required rotor rotating frequency is set by means of a nozzle apparatus or interchangeable pulleys.

When the gas is being scrubbed of liquid and mechanical impurities, the condensed moisture is caught by the separation-element's surface and it is thrown by centrifugal force onto the body's walls. Thanks to rotor rotation, contamination of the separation elements by mechanical impurities is averted.

The scrubbed gas leaves the apparatus in two streams (see figure a). Such a constructional solution enables the hydrodynamic forces that act on the rotor in the axial direction to be balanced and the work of the bearings to be facilitated.

When separating specific components from the gases--hydrogen sulfide, for example--the inner surface of the equipment's separation elements (see figure b) is sprinkled with an absorbent, and the separation process occurs simultaneously with absorption. Thanks to rotor rotation, a film is formed on the separating surface elements, changing the thickness of which can greatly increase the speed of absorption.

Preliminary tests have shown that this equipment can achieve practically complete scrubbing of the gas of liquid and mechanical impurities, and the speed of absorption will be an order higher than with existing absorbers.

COPYRIGHT: Izdatel'stvo "Nedra" "Gazovaya promyshlennost'", 1984

11409

CSO: 1822/360

OIL AND GAS

UDC 665.72:550.8

SULFUR-FREE GAS SUPPLY FOUND FOR NEW ASTRAKHAN GAS REFINERY

Moscow GAZOVAYA PROMYSHLENNOST' in Russian No 6, Jun 84 p 42

[Article by O. I. Serebryakov and V. A. Grigorov (Caspian NIKL [Scientific-Research Logging Laboratory]): "The Astrakhan GPK: Prospects for Supplying It with Sulfurfree Gas"]

[Text] Gas from the Neogene-Anthropogene Complex can play a decisive energy role in solving the problem of supplying gas to the Astrakhan GPK [Gas Refining Complex], which is under construction, since this gas is dry, rich in methane, does not contain harmful impurities, and can be used without preliminary treatment.

Because of the construction of a gas-refining complex (GPK) at the base of the Astrakhan gas-condensate field and the necessity for supplying this complex with sulfurfree dry gas, the problem has arisen of quickly finding gas of this type close to the enterprise being built.

Gas is present in Astrakhan dome sediments over a broad stratigraphic range--from the subsalt to the Anthropogene, inclusive. Altogether, about 15 deposits of gas, condensate and oil have been found in the cross-section. The main potential gas resources are concentrated in the subsalt sediments, to which the Astrakhan gas-condensate field is confined. However, subsalt gas contains aggressive components and lies at great depths.

The rocks of the suprasalt complex, where favorable geological conditions are combined, gas deposits have been discovered, reservoir rocks of great thickness have developed widely, there are reliable cap rocks and positive structural forms, the hydrogeological conditions are favorable, and so on, are of undoubted practical interest in regard to the presence of gas.

The Neogene-Anthropogene sediments are more promising in regard to searches for sulfurfree dry-gas deposits. The productive horizons lie at shallow depths here, the reservoir formations are suitably persistent, and the rocks possess high reservoir properties.

Commercial flows of gas and gas shows from Neogene-Anthropogene horizons have been noted at a number of sections of the Astrakhan dome and adjacent areas.

For the first time, gas shows from these sediments have been established in the Astrakhan region, close to Bogdo Mountain and near Lake Naskunchak.

Commercial flows of gas from the Apsheron stage have now been obtained at the Kirikilin area, which is located in the southern part of the Astrakhan gas-condensate field.

The presence of gas of ancient Caspian and Apsheron sandstones has been established in the Azau area, which is located in the eastern part of the Astrakhan gas-condensate field.

In the southern part of the Astrakhan gas-condensate field, during drilling of an artesian well in the service section, a gas blowout occurred at a depth of 115-110 meters from a sandstone formation that lies at the roof of the Apsheron stage, as a result of which a crater 15 meters in diameter was formed. In the central portion of the field, numerous gas shows were noted from these sediments during the drilling of artesian wells in the area of exploration hole No 13. Large gas flows from Pliocene-Anthropogene sediments were noted in the Krasnoyarsk area, in the southwestern portion of the Astrakhan field. Gas shows from said rocks were recorded in a number of mapping holes that were being drilled during a geological survey of the left-bank portion of the Astrakhan dome.

Aside from the areas cited above, commercial gas has been established also in commercial quantities in Neogene-Anthropogene sediments in regions adjacent to the Astrakhan gas-condensate field. For example, in the Polevoy area, west of the Astrakhan dome, flows of dry gas were noted from the Neogene in the 284-264 meter interval at holes Nos 361, 362 and 363, and free gas was obtained from hole No 364 from the Neogene at a depth of 242 meters.

Northeast of the Astrakhan gas-condensate field, flows of gas were obtained in hole No 10 of the Port-Artur area. Gas flows were recorded from Pliocene sandstones in the Auketaychagyl (well G-12, at a depth of 195 meters), Aral-Sorskaya (well 107, at a depth of 233 meters) and a number of other areas. In all cases the gas deposits were covered by highly mineralized water.

Thus, the data cited above on the presence of gas in Neogene-Anthropogene sediments testify to the promise of this complex. At the same time, it should be noted that, as a whole, the question of the commercial evaluation of the sediments described remains poorly studied up to now.

COPYRIGHT: Izdatel'stvo "Nedra" "Gazovaya promyshlennost'", 1984

11409

CSO: 1822/360

GYPSUM AT ORENBURG, ASTRAKHAN, YAKUTIA MISLED GEOLOGISTS

Moscow GAZOVAYA PROMYSHLENNOST' in Russian No 6, Jun 84 pp 42-43

[Article by I. S. Gutman and V. Ye. Kopylov (MINKhiGP [Moscow Institute of the Petrochemical and Gas Industry imeni akademik I. M. Gubkin]): "Peculiarities in the Distribution of Gypsum in Carbonate Strata"]

[Text] As a result of research conducted at the Orenburg and Astrakhan fields and in the Botuobinsk region of the Yakutsk ASSR, it has been established that inadequate consideration of the nature of the distribution of gypsum in the carbonate cross-section leads to distortion in the indicators of porosity and gas saturation of the productive rocks and, as a consequence, to underestimation in assessing gas reserves.

While studying the peculiarities of change in open porosity and other parameters in the log of the Orenburg Gas Condensate Field (OGKM), attention was devoted to the presence in the Arti and Sakmara stages of formations that are marked by anomalously high values of open porosity and of water saturation. Various determinations of open porosity have reached 32 percent, water saturation 50 percent. Thus, in well No 311, one of these intervals lies at a depth of 1,384-1,395 meters.

It is characteristic that the permeability of the collectors, according to coring, does not exceed $1 \cdot 10^{-15} \text{ m}^2$ in the overwhelming number of intervals with such anomalous porosity values, a fact that explains the low rate of flow of gas from them. Also established was the complete absence of a statistical tie between the porosity and the permeability, the presence of which is characteristic for high flow rate sections of the log of the Middle and Upper Carboniferous, and also of the Assel' stage.

The cause of the anomalously high values of open porosity and low permeability is sulfation of these parts of the cross section. In this case, the degree to which the rock has been gypsumized is the determining value.

Inadequate consideration of the sulfation of collectors leads to distortion of parameters when calculating hydrocarbon reserves. This is because the calculations employ an overstated porosity, which is obtained as a result of the

recording of an additional volume of interstices that were formed during losses of crystal water by the gypsum. It is this picture that was observed during a recent recalculation of gas reserves and accompanying components of the OGKM, where determinations of porosity for the upper part of the Arti and the lowermost stratum of the Sakmara stages, which exceeded 2-fold to 2.5-fold the values of this parameter throughout the remaining portion of the productive cross-section, were adopted for the calculation. The point of view adopted in this case, that the influence of sulfation on the rock's collector characteristics was insignificant, is explained primarily by the fact that the gypsum content was attributed not to separate portions of the cross-section but to the thickness of the productive series as a whole. An analysis of a detailed correlation of cross-sections of holes indicates that the gypsum is confined to precisely defined portions of the cross-sections. As a rule, it occurs in the hollow space of limestones that lie under and between anhydrite formations.

This important consistency will enable the gypsumized portions of the cross-section to be localized. It is explained by the conditions for deposition of the sediments in the process of change of the sea water's salinity. During the evaporation of sea water with an ordinary salt concentration, carbonates first precipitate out into the sediment, where there is a 4-fold rise in the concentration of the water (in comparison with the initial concentration) the sulfates drop out, and when the concentration increases 12-fold halite drops out. A further rise in concentration leads to the precipitation of magnesium and potassium salts and bischofite.

At the initial stage of halogenesis, when the solution is still not saturated enough with salt, first, followed by carbonates, hydrated calcium sulfate--gypsum--is precipitated, which, binding the excess water, raises the salinity of the sea water and creates the prerequisites for the precipitation of anhydrous calcium sulfate--anhydrite--from the solution. At this stage, there occurs a penetration of solutions that are saturated with salt into the hollow space of the carbonates, which make up the bottom of the basin. In the final analysis, all this leads to the formation of gypsum in this space.

The indicated sequence in the precipitation of sediments can be broken as a result of change in concentration of the solution, caused by a shift of climatic or geographic conditions or other factors. Periodic change of these conditions creates the prerequisites for forming cyclically constructed series of sediments.

The upper portion of the Arti stage of the OGKM is one of the examples of such cyclic structure, where each new cycle is started with the sedimentation of carbonates, then the salinity of the sea water increases, as a result of which gypsum is first deposited, and then later on anhydrite. Later the sediment-forming sequence is broken by a lessening of concentration of the solution, and carbonates, instead of halite, again start to be deposited, and the cycle is repeated.

Later, with submergence and rise in pressure, the gypsum that was deposited on the carbonates dehydrates, with the forming of anhydrite. Only the gypsum contained in the pores of the limestone remains unchanged, the rigid limestone skeleton preventing the effect of the pressure on the gypsum found in the hollows.

Thus, the following sequence in change of types of rocks is established, from the top, along the cross-section: limestone, gypsumized and anhydritized limestones, and anhydrites. In other words, if, along the cross-section, beginning at the top, carbonate rocks are replaced by anhydrites, then there is every reason to believe that gypsum is present in the hollow space of these carbonates.

However, in those cases where the transition from carbonates to halogenic-sulfate sediments goes through clayey varieties, then gypsum and anhydrite are not present in the carbonate pores and crevices, as a rule, since the clays are good water-confining strata. The Astrakhan gas condensate field, where a member with clays of Arti-Assel'sk age lies between productive Bashkir-stage carbonate sediments and the halogenic-sulfate Kungur series, is an example.

The lithologic cross-section of the discovered fields of the Botuobinsk region has much in common with the OGKM cross-section. The productive sediments in both cases are represented by carbonate rocks which are replaced by salt series from the top, along the cross-section. At Yakutsk ASSR fields, the same as at the OGKM, the transition from carbonates to salts occurs through an interbedding of anhydrites and anhydritized limestones and dolomites. The fact that the permeability of collectors is low where the values of open porosity are large is common.

In coring from sediments of the Osa and Yuryakh horizons of the Botuobinsk area, gypsum is recorded in solitary holes. This apparently also explains a point of view which has been asserted, that the effect of the gypsum on collector properties is not substantial. Basically, we are confronted with that same posing of the question of recalculating the OGKM's hydrocarbon reserves when the gypsum content has been attributed to the whole thickness of the productive horizons.

However, since the gypsum was confined to clearly defined intervals of the cross-section, in examining the dependence of the sediments' productivity on inhomogeneity (particularly from the point of view of sulfation thereof), we understand why, in testing limestone and dolomite formations that are in direct proximity to anhydrite intercalations and are marked as good collectors by coring and geophysical data, gas influxes are absent. The question consists only in why the amount of gypsum recorded in the core is insignificant. It must be noted that gypsum is an extremely unstable mineral, it is very sensitive to increased pressures and temperatures, and it is highly soluble. If, while processing OGKM coring, dehydration of the gypsum has occurred during extraction and drying of the samples, this question still is not clear for Botuobinsk region sediments.

Since the thermobaric conditions for the deposition of productive sediments and the parameters for sinking OGKM and Botuobinsk-region holes are essentially different, then, in our view, it is extremely likely that the gypsum is dehydrated and (or) dissolved in Osa and Yuryakh horizon rocks directly during the drilling process.

COPYRIGHT: Izdatel'stvo "Nedra" "Gazovaya promyshlennost'", 1984

11409

CSO: 1822/360

GATHERING SYSTEM AT BAKHAR OFFSHORE FIELD REFORMED

Moscow GAZOVAYA PROMYSHLENNOST' in Russian No 6, Jun 84 pp 44-45

[Article by R. I. Asadov (NGDU [Oil and Gas Recovery Administration] imeni A. P. Serebrovskiy): "Experience in Gathering and Transporting the Output of an Offshore Field"]

[Text] An optimal system for gathering and transporting output which entails minimal losses of output and a minimal number of hydraulic engineering structures and underwater pipelines, the selection for each platform of a well thought-out operating scheme for gathering the gas and insuring the most complete operating safety of offshore platforms, and so on, will help to increase gas and gas-condensate recovery in offshore-platform areas.

Experience in developing fields in the Caspian Sea has enabled definite experience to be gained in creating systems for building up facilities for oil and gas-condensate fields on sea-water bodies.

The Bakhar field is located in the open sea, is deeplying and has a high formation pressure. Certain consistencies in distribution of the deposit are observed over the vertical cross-section: the upper deposit is gas condensate and next are gas condensate with oil shoestrings and then purely oil.

Prior to discovery of the subjacent oil horizons, the operation involved gushing wells, the majority of which gave gas condensate.

The single-pipe system for the combined gathering and transporting of the output that was proposed by A. G. Baronyan and S. A. Vezirov was chosen as the most rational one for the field. The wells' output came along a "comb" array of gathering pipelines to grouped metering installations, where it was redistributed over trunk pipelines. The output was sent along them through gas-separation centers.

This system was profitable for the Bakhar environment. At the same time, experience in operating the field showed some of its deficiencies: a mixing of various types of hydrocarbons with different physico-chemistry properties led

to losses of light fractions of the crude and gas condensate, which were carried away by the gas in the form of dispersed drops and evaporated during demulsification of the crude when it was heated to temperatures of 60-70 degrees C. The combined gathering of oil and gas and the high well-mouth parameters cause pulsing operation of the trunk pipelines and the "comb" array of "well-to-GZU [gas-metering installation]" gathering lines, and this, in turn, leads to pulsing operation of the wells, during which oil and gas are lost.

The single-pipe system does not allow the wells' flow rate to be measured in terms of liquid and gas.

During the last five year the number of producing wells has almost doubled, and 20 percent of them are being worked by the gaslift recovery method. The wells are marked by a large spread in well-mouth parameters and inhomogeneity of output. All this caused the combined system of gathering to become inefficient and to be rejected.

All cluster-type and solitary offshore stationary Bakhar platforms are now equipped with BT-100 operating modules, the main operating components of which are the GZh 100x1000, GZh 100x1200 and GZh 100x1400 vertical gas-and liquid separators.

All the field's operating wells have been arbitrarily divided, depending upon well-head pressure, into the following groups:

- 1) wells that flow with gas condensate and oil ($p_{\delta y \phi}$ [wellhead pressure] > 6.5 MPa);
- 2) semiflowing-and-gaslift oil wells ($3 \text{ MPa} < p_{\delta y \phi} < 6 \text{ MPa}$); and
- 3) gaslift oil wells ($p_{\delta y \phi} < 3 \text{ MPa}$).

The output of all wells of the first group, in undergoing separation at the operating installations that are equipped with automation, pass separately along the gas-and-liquid "comb" array gathering lines and arrive directly at the offshore gathering points, or they arrive there through neighboring platforms, being transported together with the output of those platforms.

The output of wells of the third group is transported to intermediate gathering points, where the crude, in passing through separation at low-pressure traps, is pump-injected into collectors.

The offshore gathering points have been constructed on the base of previously existing grouped metering installations. The MNGSP's [offshore oil-and-gas gathering points] collect, partially treat and transport the field's output to the terminal structures. The main production-equipment component modules of the MNGSP's are:

the inlet and outlet distribution gate-valve units;

the unit of high-pressure gas separators with gas scrubbing (p_{pa6} [operating pressure] = 6 MPa);

the medium- and low-pressure oil-separator units, whose designed pressure are, respectively, 4 and 1.6 MPa;

the component for recording the output transported;

the unit for pump injection with buffering vessels (800 m³) for receiving gas-lift-well output; and

auxiliary units.

Startup of the offshore gathering point has already enabled gas recovery to increase by 10 percent. The startup of the MNGSP's full capacity and the construction at Bakhar of a planned compressor station will enable losses of liquid phase during transport to be reduced still more.

Choice of an optimal number of separation stages is one of the main problems in designing the development of a field, especially an offshore field that is many kilometers from the shore structures. As is known, during single-stage separation the gas phase is intensively isolated by the separators and, along with the light hydrocarbons, a large amount of heavy hydrocarbons from the crude pass into it. At the same time, during multistage separation, that is, where there are small pressure differentials, a large amount of propane and butane fractions go off into the liquid collectors. Both the one and the other are undesirable, since, when transporting multiple-component mixtures over both "comb"-array field collectors and trunk gathering lines over a great distance, where there are great pressure differentials in the pipelines, intensive phase transformations of the hydrocarbons occur, that is, condensate forms in the gas collectors and gas is separated in the liquid collectors. This, first, disturbs the stable operating routine of the pipelines, and, second, it increases the potential for hydrate formation during fall and winter.

Analysis of the gathering system has enabled discovery that three-stage separation is more rational in the Bakhar environment:

the first stage (p_{cen} [separation pressure] = 6.7-6.5), at the operating modules of stationary platforms;

the second stage (p_{cen} = 6.3-6.0 MPa), at the shock separators of the MNGSP's high-pressure separation units; and

the third stage (p_{cen} = 6.1-6.0 MPa), is final separation of the gas at the dewatering separators of the BSVD's [high-pressure separation units] of the MNGSP and preparation for transport.

Later, with startup into operation, degassing of the liquid, which has been reduced under separation pressure from the BSVD's and BT-100's of the platforms, will be accomplished at medium-pressure separator units.

The key factor in the technology for gathering and transporting output in the offshore stationary-platform environment is hydrate formation. Hydrates of hydrocarbon gases not only constrict the passage area of the pipeline's cross-section but also, by increasing the gas line's hydraulic resistance, reduce efficiency.

As is known, the main prerequisites for hydrate formation are: the presence of condensed moisture in the gaseous medium, a temperature that is low enough and a pressure that is high enough, and a certain density of the hydrate-forming mixture. The relative density of Bakhar gas that is transported averages 0.7, and the pipeline pressure is 6.5 MPa.

Thus, the potential for hydrate formation appears at a temperature of + 18 degrees C. The temperature of the sea during autumn and winter falls to + 3 degrees C.

The drive against hydrate formation at Bakhar is being waged by introducing antifreeze--methyl alcohol--into the pipelines, for which purpose methanol units with tanks for storing methanol and ND-40 and ND-25 dosing pumps have been built at each platform.

Introduction of the two-pipe gathering and transporting system at Bakhar has enabled the colossal output losses caused by the forming of collapses in the pipeline to be reduced to a minimum and has enabled a saving of costly antifreeze.

COPYRIGHT: Izdatel'stvo "Nedra" "Gazovaya promyshlennost'", 1984

11409

CSO: 1822/360

OIL AND GAS

SCIENCE COUNCIL PLANS TO MASTER CONTINENTAL-SHELF OIL

Moscow GAZOVAYA PROMYSHLENNOST' in Russian No 6, Jun 84 p 45

[Article by V. P. Podkovyrin (VNIPIorneftegaz [All-Union Scientific-Research and Design Institute for the Design of Offshore Oil and Gas Facilities]): "At the Scientific Center for the Offshore Subbranch"]

[Text] A meeting of the Council of Directors of the NTTs [Scientific and Technical Center] of VNIPIorneftegaz of Mingazprom [Ministry of Gas Industry] was held in Moscow. The council's members are the first managers of regional institutes that are working in the area of developing and creating means for conquering the oil and gas resources of the USSR's continental shelf.

Representatives of GKNT [State Committee for Science and Technology], Mingazprom's central staff and allied branches of the economy took part in the meeting.

The NTTs supervisor--VNIPIorneftegaz Director Professor and Doctor of Engineering Sciences R. A. Maksutov--reported on the methodics bases for developing long-term specific-purpose integrated programs for mastering offshore oil and gas resources.

Representatives of the problem-area councils of NTTs reported on the basic directions of their activity and on current plans.

In accordance with the Mingazprom decision that defined in 1983 the program for the NTTs's work, a large number of tasks have been met up to the present, particularly:

a parametric series of functional, technological box modules for the upper structure of the platforms has been developed for oil, gas-condensate and oil-and-gas fields;

research has been done to create ice-and-soil islands for drilling exploration holes, and baseline data (ID) have been prepared for the design work;

research has been done to create ice islands from natural ice, including ice many years in age and icebergs, and, for purposes of drilling exploration holes, ID have been prepared for the design work;

an engineering task has been issued for the development of a system for monitoring and controlling the process of drilling offshore wells in accordance with surface and bottom-hole parameters, to include the communication channels, self-contained deep-sea recording devices and surface control devices, and the system for collecting, transmitting and processing information;

preliminary designs have been developed for creating ASU TP's [automated system for controlling industrial production] based upon third-generation computers and microprocessor equipment for operating complexes for the offshore recovery of oil and gas; and

Initial requisitions and orders have been prepared for developing structure for stationary platforms for drilling and operating a cluster of oil and gas wells at water depths of up to 250 meters.

The chief of the Oil and Gas Section of GKNT, V. I. Mishchevich, spoke at the meeting. Along with a positive assessment of the NTTs's activity, he noted deficiencies in its work and singled out urgent tasks for the offshore subbranch.

The Council of Directors adopted the appropriate decision.

COPYRIGHT: Izdatel'stvo "Nedra" "Gazovaya promyshlennost'", 1984

11409

CSO: 1822/360

NEW MUD PUMP MANIFOLD SYSTEM TESTED, DISCUSSED

Moscow NEFTYANIK in Russian No 7, Jul 84 p 14

[Article by V. Minenkov, of VNIKRneft': "New Pump Manifold System Developed by VNIKRneft' for Drilling Equipment May Become a Resource for Increasing the Technological Efficiency of the Preparation and Treatment of Drilling Mud"]

[Text] Mud pumps are used to introduce powdery materials during preparation and treatment of drilling mud, and to mix these materials into the circulation system. This leads not only to large expenditures of energy, but to a shortening of the period between maintenance operations on the pumps. At the same time, treating and charging the mud with powdery materials while drilling and flushing the well become impossible when both pumps are working to circulate the mud.

A new manifold equipment system for preparation and treatment of drilling mud is devoid of these deficiencies, as is shown in the figure.

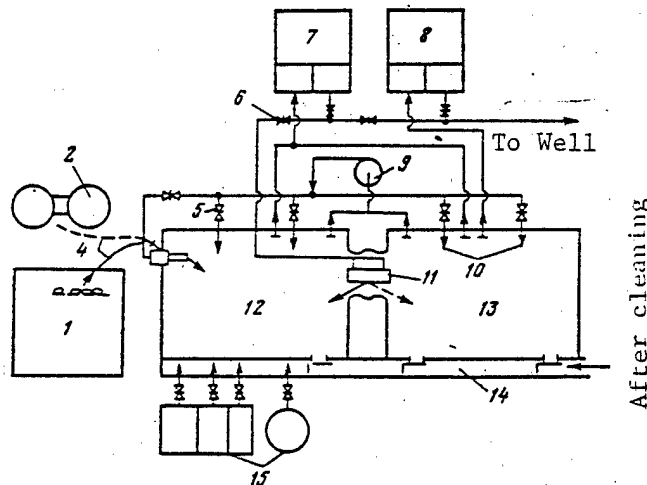

Efficient Pump Manifold System for Drilling Mud Preparation and Treatment Equipment:

- 1--Storehouse for powdery materials; 2--Drilling mud preparation unit; 3--Water mixer [item 3 not indicated on figure]; 4--Water mixer intake line; gate valves: 5--Low-pressure (valve); 6--High-pressure valve; 7,8--Mud pumps; 9--Centrifugal sludge pump; 10--Hydraulic mixers; 11--Dispersator; 12,13--Receiving tanks; 14--Circulation system flume; 15--Chemical reagent unit

Intakes for the centrifugal sludge pump and the hydraulic dispergator are different from the conventional type.

Using a sludge pump which is connected to the mud pump receiving tanks and the water mixer, both of which feed into the drilling mud preparation unit, provides an intake for powdery materials (clays, weighting agents, chemical reagents) without drawing on the mud pumps, the capacities of which are better used in well-flushing. The centrifugal sludge pump can also be used to mix mud in the tanks and pump mud to the pit or the spare tank.

The dispergator increases the dispersibility of the clay both during its preparation and during drilling mud treatment. It makes possible the introduction of chemical reagents in powder form, without having to dissolve them beforehand. Pumping drilling mud and chemical reagents through the dispergator brings about complete dissolution of the latter, and intensifies the interactive process of the drilling mud components. Here, there is a reduction not only in preparation and treatment time for the drilling mud, but also in clay and chemical reagent outlays, and even outlays of weighting agents (see table).

<u>Index</u>	<u>Basic Version</u> <u>Well 9 Lesa</u>	<u>New Version</u> <u>Well 16 Sagvamichao</u>
Material outlay (tons)		
Bentonite clay	301.00	180.50
FKhLS [not further identified]	66.40	42.00
Caustic soda	8.10	5.17
Barite Weighting Agent	856.20	513.90
Time spent in auxiliary operations connected with preparation and treatment of mud (in hours)	1,606	1,349

The last circumstance is explained by the fact that the introduction of aqueous chemical reagent solutions into weighted drilling mud would unavoidably lower its density, making it necessary to bring the mud weight back up to normal. A comparison of drilling data for Well No 9 Lesa (Basic Version) and Well No 16 Sagvamichao (New Version) at corresponding intervals, 3,646-5,000 m., and 3,730-5,000 m. (Akhtyrskoye UBR [Drilling Operations Administration] of the Krasnodarneftegaz Association), is shown in the above table.

The centrifugal sludge pump and the powder dispersing unit, connected in the new manner, combine the operations of adding and dispersing powdery materials. The use of only one mud pump operating as a dispersing device is foreseen here. Only one centrifugal pump is needed to weight the mud during drilling.

The positive results of the new system's field tests by the Krasnodarneftegaz and Aktyubinskneft' Production Associations make it possible to recommend a general adoption of the system.

COPYRIGHT: Izdatel'stvo "Nedra" "Neftyanik", 1984

12659

CSO: 1822/412

OIL AND GAS

ORENBURGNEFT' EFFICIENCY, ECONOMY MEASURES DISCUSSED

Moscow NEFTYANIK in Russian No 7, Jul 84 pp 4-5

[Article by A. Genze and B. Danilov, Orenburgneft' Association: "On a Course of Intensification"]

[Excerpts] The Orenburgneft' Association collective has successfully fulfilled the plan for 3 years of the five-year plan and is doing good work this year. The main factors insuring the completion of the production program and the socialist obligations are progressive forms of organization and wages, active socialist competition, assimilation of new equipment and advanced technology, and the dissemination of advanced experience.

The new form of organization and wages in the brigades, based on cost accounting, with payment for finished results according to the coefficient of labor participation, has been in use since 1980 not only in special production collectives, but also in auxiliary enterprises.

The pioneer of this initiative was the leading oil recovery brigade headed by foreman V. N. Kulakov, of the Buzulukneft' NGDU [Oil and Gas Recovery Administration]. This brigade was the first to go over to integrated well servicing and they expanded their sphere of service from 58 to 96 wells without increasing the number of service personnel. This was achieved through cost accounting, cross-training workers and a whole series of organizational measures.

All technical and economic operational indicators have been greatly improved in V. N. Kulakov's brigade: the number of wells serviced has increased almost two-fold, numerical strength of brigade workers has been reduced, and the period between well-servicing operations has been lengthened to 26 days. The collective constantly overfulfills plan assignments and socialist obligations for oil and gas recovery. Thus, 2,937 above-plan tons of oil were recovered during 1983. Over the years this collective has been a leader in competition among related brigades, not only on the administration level, but on the association level, too. Many people have benefited from the experience of these right flank workers. At present within the association 1,947 workers are involved in oil and gas recovery by the progressive brigade form of labor organization, and 1,486 of them work by a single job authorization and are paid according to the results. Each brigade services an average of 60 wells.

Work continues toward the establishment of integrated brigades and expansion of their areas of service without increasing workers' numbers. An analysis of the drilling crews' work where this new method of labor organization and wages is used shows that drilling wells by contract greatly accelerates the construction cycle, by 5 to 10 days compared to the usual periods. Savings in the estimated cost of drilling operations amount to 4,000 to 9,000 rubles per completed well. The drilling crews turned out to be the winners, since their pay notably increased.

Year in and year out, the number of operations carried out by the progressive brigade method within the motor vehicle transport enterprises and construction organizations of the association has increased. By the beginning of 1984 there were a total of 643 brigade collectives working in the association by the new method. Of them, 164 were integrated, 479 were specialized, 116 were working by a cost accounting system, 364 were working by the single work-order method, 259 were paid according to work completed and 196 according to KTU [coefficient of labor participation].

On two occasions joint seminar-style classes and conferences of economists, workers, labor union employees and chairmen of coordinating councils from all oil regions were held for guidance in a competition under the motto "Oil Wells In Production" among allied brigades to shorten completion time of wells. Using the best oil recovery brigades, 11 schools were conducted in well servicing and major repairs, as well as 3 schools for construction workers and 13 schools for drillers and drilling rig erectors. The most interesting and productive classes in the schools were those for the oil recovery brigades. They were headed up by USSR State Prize Laureate, the expert G. P. Sluzhayev and the outstanding oil industry foreman V. N. Kulakov.

During the 11th Five-Year Plan we have implemented 30 important measures regarding new equipment and have incorporated 124 innovations. Total economic result derived from all the innovations incorporated during the five-year plan amount to about 10 million rubles.

A whole combination of measures to perfect methods of flooding productive strata, and faster ways of getting new fields into commercial production are being implemented on the basis of recommendations of the Giprovestokneft' Institute and this association's Central Scientific and Research Laboratory, and with the active participation of leading specialists and creative groups from the Orenburgneft' enterprises and staff. The block method, geometric grid method and repeating pattern methods of water flooding wells are used widely to increase oil output. A variation of the kinematics of the filtering streams is employed. About 90 percent waste water is injected into productive strata. Not only is the oil output from the formation increased by this method, but the problems of saving fresh water and protecting the surrounding environment are solved. At present, the association recovers 85 percent of its oil by the waterflood method.

During this five-year plan we have assimilated the technology of the combined effects of surfactant solutions and acid, and the thermo-gas-chemical

effect on the critical zone of the formation. More than 1,600 such operations have been conducted, making possible an additional 152,000 tons of recovered oil.

At the same time, an extensive series of scientific and technical and field work is being conducted in the association to combat salt deposits and paraffin accumulations. Special attention is being paid in the fields to the chemization of these processes. More than 180 wells are treated yearly, making possible an additional recovery of about 47,000 tons of oil during this five-year plan. Also, a total of 508,000 rubles were saved.

We are now aiming at reducing the volume of imported chemical reagents and replacing them with our more economical domestic variety. The Buzulukneft' NGDU Oil Field Collective No 1, headed by A. S. Prokayev, winner of the Lenin Komsomol Prize, has shown praiseworthy activity and efficiency in this affair. For the first time in the association a brigade has now been set up to introduce chemicals into the treatment of producing wells. Special equipment, a storage point for inhibitors and a center for the preparation of solutions have been assigned to this brigade. Thanks to this, the rate at which wells are treated in the field has been increased two-fold, and this has made a notable showing in output capacity of the well-stock.

Introduction of very reliable high-capacity submersible centrifugal electric pumps has been successful in the association's fields, and allows exploitation of wells with low dynamic levels. Centralization of repair and renting out of centrifugal electric pumps by TsBPO PREPU has had an obviously positive effect on this increase in reliability, allowing the operating period between servicing shutdowns to grow to 48 days.

Equipping repair brigades with the more efficient D-85 downhole motors and the newest model hoist units has reduced the time of a single well service operation to 50.3 hours, the norm being 57.1 hours, and major overhauls now take 206.3 hours at a norm of 240.3 hours.

The award-winning Orenburgneft' collective is most assiduously carrying on the battle for quickest recovery of 200 million tons of oil, starting when the fields are first developed, and is fully resolved to recover no less than 40,000 tons of above-plan crude oil. Results of the Orenburg oil workers' efforts since the beginning of the year give high hopes for success, with 10,200 tons of oil and 1.3 million cubic meters of gas recovered above the plan in the 1st quarter, comprising an economic result of 750,000 rubles in above-plan production. The many-thousand member Orenburg Collective which is part of the socialist competition for a worthy greeting of its professional holiday--the All-Union Holiday for Oil and Gas Industry Workers--remembers the main points while going about its daily affairs: to deliver maximum end results while reducing costs.

COPYRIGHT: Izdatel'stvo "Nedra" "Neftyanik", 1984

12659
CSO: 1822/412

YAKUTIYA TESTS HIGH-MOLECULAR FLOCCULANT

Moscow NEFTYANIK in Russian No 7, Jul 84 pp 12-14

[Article by Ye. Konovalov, S. Yakovlev, I. Beley and V. Artamonov of the Lenaneftegazgeologiya Geological Production Association: "High-Molecular Flocculant Polyoxyethylene Tested by Lenaneftegazgeologiya Geological Production Association for Drilling Wells in Yakutiya"]

[Text] Along with traditional polymer reagents used when drilling deep oil and gas wells, high-molecular flocculants such as polyacrylamide (PAA), polyethylenimine, Flochan, Kometa etc. are seeing increased use lately.

In 1982 and 1983, during a combined topical expedition conducted by the Lenaneftegazgeologiya Association, work was done while waterflooding wells to determine the feasibility of using still another high-molecular flocculant, polyoxyethylene (POE), which is a product of the Karbolit Scientific and Production Association of Kemerovo, and has a molecular mass of about $1 \cdot 10^6$. First, they checked the possibility of using POE directly, to cleanse drilling waters (process water and sludged salt brines) of finely-dispersed drill cuttings. Laboratory findings showed the optimum POE concentration to volume of treatment solution to be 0.005 percent to 0.007 percent. The flocculant is introduced into the drilling solution in a 0.5 percent to 1 percent solution. With respect to flocculating action, POE is not inferior to PAA, and surpasses it in technological effectiveness. Due to its nonionic nature POE may be used in a wider pH range than PAA.

Experimental research has established that during treatment with POE, the flow characteristics of low concentrations of drilling mud are improved to a greater degree than with other polymer reagents. Thus, to thicken an 8-10 percent solution of drilling mud made of low grade bentonitic powder, and having a relative viscosity on the SPV [standard field viscosometer] of 22-24 seconds and a static shear stress of 0-3/3-6 decipascals, the minimal volume of POE, calculated in proportion to the dry agent, amounts to 0.01 to 0.05 percent. In so doing, the viscosity of the mud is increased by 2-2.5 times. POE should be introduced along with other polymer reagents, such as KMTs [carboxymethyl cellulose], and hydrolyzed polyacrylonitrile ("gipan") to prevent complete flocculation of the argillaceous phase and to reduce water loss from the drilling mud.

Treatment using a combination of aluminacrylic reagent with POE, which gives, along with an increase in viscosity, the necessary static shear stress of (SNS 20-25/35-40 decipascals) with low water loss of 6-10 cm³ according to VM-6) [VM not identified further]. The reagent consists of 5 percent commercial grade hydrolyzed polyacrylonitrile, 0.3-0.5 percent POE, 2 percent technical-grade aluminum sulphate and 0.2-0.4 sodium hydroxide. Amount of the reagent added to the drilling mud equals 5-10 percent.

An aluminacrylic reagent together with POE was tested during drilling of Well No 483 in the Kumakhsкая area at the 2,850-3,150 m. interval. The object of the treatment was to improve the flow characteristics of the carbonate-clay drilling mud. The combined reagent was prepared in a mud mixer. First, aluminum sulphate was dissolved in water, then calculated amounts of hydrolyzed polyacrylonitrile and POE were added. After the POE was completely dissolved, sodium hydroxide was added until the pH was increased to 10-10.5. Twelve cubic meters of combined aluminacrylic reagent was prepared and added to the circulating drilling mixture. As a result, the relative viscosity increased from 24-25 to 29-30, and the SNS increased from 3/5 to 20/35 decipascals. This improved bottom hole cleaning and allowed drilling to continue. Total input of POE in treating 150 cubic meters of drilling mud amounted to 40 kg.

Using mud gel and POE, uniformly highly consistent mixtures (VKS) can be prepared for use in isolating lost circulation zones. To mix mud for plugging-back operations, raise the mud gel concentration to 15-30 percent, and the POE to 0.1 to 0.5 percent. Preparation of a VKS consists in treating high-viscosity drilling mud (relative viscosity=60-80 centipoises) with a 1-2 percent solution of POE at a volumetric ratio of 10 to 1. The VKS obtained acts as a viscoplastic system with negligible elastic properties. It achieves an elastic strength of 2-2.5 kilopascals, is stable in a medium of fresh or mineralized water and can be used as an independent back-plugging mixture when eliminating partial low-intensity losses of circulation.

However experience of the Lenaneftegazgeologiya PGO in combating circulation loss shows that the best result can be obtained by using consistent mixtures of a given compound for formation squeeze treatment to contain a cement solution in the borehole area of a lost circulation zone immediately prior to adding the cement solution. The technological processes of zonal isolation operations were tried out on four wells in seven isolation operations and worked quite effectively. In all cases, complete losses of circulation were eliminated after the first isolation operation.

It is comparatively simple to prepare highly consistent mixture under drilling conditions. In a jet hydraulic mixer, prepare 15-20 m³ of high-viscosity drilling mud (relative viscosity=60-100 centipoises), and a 1.5-2 m³ POE solution (for example, a 1 percent concentration) measured from a cementing unit. Drilling mud is then fed into the injection line by the mud pump and the cementing unit pumps the POE solution into the drilling mud stream through a branch of the standpipe. As the solutions mix, a mud-polymer VKS is formed which then immediately falls into the drillpipe column. After the VKS is introduced, the cement solution is injected into the drill pipe, and then

the displacement fluid, the volume of which is decided based on the calculation of the entire volume of the VKS squeezed into the lost circulation zone and a portion of the cement slurry.

As shown by laboratory research, polyoxyethylene effectively lowers the filtration of cement solutions. Thus, addition of 0.2-0.3 percent of POE to the weight of the cement lowers cement solution filtration 3-4 fold. At the relatively low temperatures characteristic of geologic sections of the majority of Yakutia's exploration areas, adding POE to the cement solution negligibly (by 15-20 percent) extends cement setting time and has practically no effect on the mechanical strength of the concrete.

Field tests of cement slurry with POE and calcium chloride added were conducted while cementing a 146 mm flow-string in an overlap interval of productive horizons which had abnormally low stratal pressures. (Well No 763 in the Ozeroye area). POE was immediately introduced into the liquid of the mixture, a calcium chloride solution. According to AKTs [not further identified] data, high-quality bonding was obtained between the cement stone, the drillpipe column and the formation rock in the entire interval where this cement solution was used. A commercial flow of gas was obtained during the tests.

A recommendation for wide use of this new reagent is possible thanks to results of POE field tests. The relatively high cost of the experimental consignment of POE supplied to the Lenaneftegazgeologiya PGO, that is, 7,385 rubles per ton, is compensated by the low amounts used in all types of treatment: 3 to 4 tons for the annual deep well drilling of 95,000-100,000 meters, and by the opportunity to utilize it in various technological operations, a feature which is extremely important in the conditions of the extreme North.

According to calculations of field test results, the economic result of using 1 ton of POE to isolate zones of lost circulation cost 87,760 rubles.

COPYRIGHT: Izdatel'stvo "Nedra" "Neftyanik", 1984

12659
CSO: 1822/412

OIL AND GAS

ORENBURGNEFT' ASSOCIATION OPERATIONS DISCUSSED

Moscow NEFTYANIK in Russian No 7, Jul 84 pp 2-4

[Article by R. Khramov, Orenburgneft' Association general director: "Decisions of the CPSU in Practice"]

[Excerpts] In order to carry out decisions of the 26th CPSU Congress and subsequent plenums of the CPSU Central Committee, Order of Labor Red Banner workers of the Orenburgneft' Association have implemented an extensive combination of organizational, geological and technical, and popular and political measures, designed to fulfill planned assignments and socialist obligations. The results of this task are good.

The petroleum recovery assignment for 3 years of the five-year plan was carried out ahead of schedule, by 22 December 1983. Above-plan oil recovery amounted to 180,700 tons. Last year, above-plan oil recovery amounted to 25,400 tons, and 29.4 million cubic meters of gas. The plan to increase oil and gas reserves was fulfilled. Two fields, the Kristal'noye and Alyab'yevskoye, in the Buguruslan oil region, have been put into exploratory operation. One hundred forty-four new oil wells and 24 injection wells have gone into operation.

Thanks to an improvement in the system of oil field development and the incorporation of new equipment and advanced technology, automation and progressive forms of labor organization, labor costs per well have been reduced by 7 percent and the period between servicing operations for oil wells has increased by 4 percent.

In 1983, 92 percent of recovered petroleum was from fields which are completely automated. One hundred ninety-five "Sputnik" petroleum measurement devices are in operation in the fields, 16 automated block-cluster and pressure-normalizing pumping stations, and 89 automated boiler houses. Tabulation of each brigade's recovery has been organized at all fields and within brigades, and 96 percent of all petroleum is produced using automated non-tank collection points to gage petroleum.

The volume of development well drilling for 3 years of the five-year plan has increased by 9.2 percent, and completion time per well has been reduced by a quarter day.

In our opinion, these gains are related in large part to the introduction of new equipment and technology, the scientific organization of labor, the organization of integrated and contract brigades, combining the professions and expansion of maintenance areas. In this regard I venture to introduce a few more figures showing the volume of work carried out. In the present five-year plan 155 measures using new equipment and advanced technology have been incorporated into our operation, as well as 92 developments from scientific and research and design organizations, with an overall economic result of 16.2 million rubles. Use of 2,683 innovations and 96 inventions has netted an economic result totaling 9.3 million rubles. Per association, 78.8 percent of labor-intensive processes have been mechanized. Organization into brigades, and labor incentives in the enterprises encompass 5,400 persons. Of that number 2,450 are oil field workers, 1,240 are drilling personnel, and 600 are construction workers.

Beyond the affairs of production, we have not forgotten about improved living conditions for the oil field workers. Just last year 20,800 square meters of living space were constructed and more than 700 oil workers' families moved into new quarters, improving their living conditions. Three stores and two cafeterias have been opened, a sanatorium and dispensary built, and a livestock farm was put into operation.

However, speaking today of the positive results of the association's labor collectives, we must also talk about the fact that all the resources for increasing operational efficiency are not being used, and there are still shortcomings and weak points to be eliminated. This was the main item of discussion at the aktiv of January of this year. Aktiv speakers noted that in 1983, oil and gas extraction administrations were operating at levels beneath their capabilities, i.e., the operational coefficient for active wells was reduced by 0.013 and their coefficient of use by 0.005. The association's drilling enterprises lost a lot of footage due to a shortage in the needed range of drill bits. As before, there are still a lot of delays in wells shut down for repairs, killing the wells, and well completion. Much of this is linked to a shortage of special underground and well-overhaul machines, but much of it happens because of a lack of organization in the efforts of repair brigades, equipment transport and other services.

Capital construction should be mentioned separately. The Orenburgneftestroy Trust Association's own construction organizations have been working below their potentialities. We have many grievances against the contract construction brigades of Minneftegazstroy's Vostokneftestroy Trust, Mintyazhstroy's Orenburgtyazhstroy Trust, Minenergo's Orenburgsel'elektroset'stroy Trust and Minvodkhoz RSFSR's Orenburgvodstroy Trust. Because of them, construction of a number of important industrial projects in Buzuluk, Buruguslan and Sorochinsk are dragging on. This prevents the association from putting drilling and recovery production personnel to work.

Results of the work of the Orenburg oil workers in 1983 prove that there are still many resources within the association's enterprises and organizations which, if used, would permit future work to be done more stably and efficiently.

Hence, the Order of Labor Red Banner Collective of the Orenburgneft' Production Association accepted socialist obligations for 1984 in which, in particular, it is stipulated: to fulfill the plan for oil and gas recovery ahead of schedule and to recover 40,000 tons of above-plan petroleum, to complete 2,000 meters of above-plan drilling, to shorten completion time per well against 1983 by 3 days and to increase labor productivity by 1 percent above the plan.

In 1983, as in past years, the association continued operating at decreasing oil recovery levels for a variety of objective reasons. This circumstance forces us to concentrate special attention on increasing the level and quality of geological and exploratory operations, to directing all our efforts to the search for new oil deposits, to improving the organization of drilling operations and developing exploratory wells and to concentrating the volume of exploratory drilling in the main and most promising regions of the oblast.

With this, accelerating the development of new oil fields and making them operational takes on special significance. From this viewpoint, the Kamalyk-Chagan Devonian uplift zone is of great practical interest. This zone is situated in the Southern Buzuluk Basin. During a test, exploratory wells drilled on the Zaykin, Rostoshin and Miroshkin uplift of this zone produced an influx of oil of 126 to 252 tons per day and gas recovery of 180,000 to 215,000 cubic meters per day.

Results of geological and exploratory operations confirm the high assessment of this area, making it possible in the near future to suspend the association's decreasing rate of oil recovery, and then by responsible deployment of drilling and construction operations, to establish a new oil and gas recovery region in the oblast with an oil recovery level of up to 5 million tons per year.

To do this, we need to begin drilling development test wells in the Zaykin field this year, and to prepare the technical documents for the construction of test operation facilities.

In connection with the labor intensiveness of this region's drilling operations, which are related to well depth and a shortage of association drilling personnel, special attention will be focused on putting together drilling crews, building new, and reinforcing existing UBR (Drilling Operations Administration) bases, on material and technical supply and transport enterprises. An increase in the volume of housing construction is also required.

COPYRIGHT: Izdatel'stvo "Nedra" "Neftyanik", 1984

12659
CSO: 1822/412

OIL AND GAS

CASPIAN NEFTYANYE KAMNI FIELD REVIEW AND UPDATE

Moscow PRAVDA in Russian 3 Aug 84 p 1

[Article by L. Tairov, PRAVDA correspondent: "The Heights of Neftyanje Kamni--Reporting From an Offshore Oil Field"]

[Text] Azerbaijan SSR--Soon it will be 35 years since the legendary oil field in the open sea, Neftyanje Kamni, was founded. Above the Caspian, around the once moss-covered threatening rocks, a city with streets--steel catwalks more than 200 km long--has been erected by the huge petroleum industry. From derricks, compressor stations and electric power plants, to the seagoing ships attached to it, a city with multi-story stone housing with all the municipal conveniences, including a sports complex and a park has been built here. The flowers and trees are planted in earth which was brought from the mainland.

How is the celebrant of this anniversary, this oil field in the open sea, getting along today? N. Zaidov, party committee secretary of the Production Association imeni 22nd CPSU Party Congress, which was established on Neftyanje Kamni, responds to this question:

"Almost half the oil in the field is extracted by the most efficient and economical method--natural flow. For the past 6 months, duty on the steel island has progressed at an increasing pace in spite of the frequent storms. We've recovered about 34,000 tons of oil and gas condensate above the plan, which substantially exceeds the socialist obligations. Labor productivity has risen by 1.6 percent against the target, and production cost has been lowered by 0.9 percent. Patriotic initiatives are growing.

Our drilling people are actively assimilating the brigade contract, by which wages are paid for fully completed wells. This has drastically improved the quality of their drilling progress and construction. The Neftyanje Kamni Collective has made above-plan profits of almost 850,000 rubles, and has saved about 2,000 tons of fuel and more than 1.15 million kilowatt-hours of electric power."

The veterans are all ears concerning what's being accomplished nearby at the new imeni 28 Aprelye Field. In all, there are 10 wells in operation on steel

islands which have already been constructed. And what wells they are! Each of them produces up to 400 tons of excellent crude per day. A. Siradzhev, director of the Kaspornftegazprom All-Union Production Association's geology department, defines the situation more accurately:

"The explored area is a unique continuation of the Neftyaneye Kamni field. We are obtaining a huge increase in oil reserves from this field. We are already selecting the best foremen for drilling operations."

These are: G. Ibragimov, delegate to the USSR Supreme Soviet, G. Aliyev, S. Avanesyan, S. Abdullayev, Sh. Gadzhiagayev, A. Babayev and Sh. Gadzhimetov. They will be working on the gigantic platforms made of steel tubing which are solidly set into the floor of the Caspian.

It is known that the ancient Caspian is stormy almost 300 days a year, and that during those times the small collective of drilling hands is left to face the elements. They endure with honor. Here is a chronicle of the last few months: 20 February, the collective of the Kaspornfteft' Installation has fulfilled their assignment for the quarter. On 10 and 15 March they struck powerful oil gushers from the 5th and 6th wells. On 15 April, the brigades of drilling foremen D. Abdurakhmanov, M. Sultanov, G. Isayev and M. Aliyev completed drilling wells with record speeds for this area, about 800 meters per rig in a month, and completed their fourth-year assignment. In the first days of May the drilling of a well was begun from the third platform in succession. On 18 July, the next well was put into production from the first platform.

Fifteen more wells are scheduled to be put into production at the imeni 28 Aprelya Field before the end of the five-year plan. Judging by the collective's attitude to work, the wells will go into production far earlier. Neftyaneye Kamni goes on!

12659
CSO: 1822/412

CASPIAN EXPERIENCE SPEEDS PRESENT-DAY CONSTRUCTION

Moscow IZVESTIYA in Russian 25 Jul 84 p 1

[Interview with Kurban Abasovich Abasov, director of the Kaspmoreneftegazprom All-Union Industrial Association, Hero of Socialist Labor, and delegate to the Supreme Soviet of the USSR, by Sh. Medzhidov, IZVESTIYA correspondent in Baku: "The Steel Islands of the Caspian"]

[Text] Who does not know the famous Neftyanye Kamni in the Caspian? This hand-built city on piles is a living legend of the courage and valor of the Azerbaijani oil workers who have become pioneers of offshore oil recovery. During the 40-plus years, in which the Caspian oil and gas fields have developed, the pileworks and uniquely constructed hydro-technical structures have moved far into the sea. For the first time in practice, the domestic shelf oil recovery industry has succeeded in drilling producing wells in sea depths of over 100 meters. Today 11 such wells produce thousands of tons of oil daily.

We are talking with K. Abasov, director of the Kaspmoreneftegazprom All-Union Industrial Association, Hero of Socialist Labor and delegate to the Supreme Soviet of the USSR:

[Answer] The intensified development of the oil and gas fields of the continental shelf is characteristic of the last decade in the oil industry. The rich practical experience which the Azerbaijani oil workers have accumulated in this matter has once again given them a place in the first ranks for the conquest of marine mineral resources. In particular, after intense geological and exploratory operations, we obtained convincing proof of the promising nature of the accumulations south-east of Neftyanye Kamni, where the sea is over 100 meters deep. A fundamentally new design solution was required to overcome these depths without using the offshore pier method. Within a short period of time, from 1980 to 1982, a production facility for the assembling of elaborate offshore stationary platforms was built by engineers and technicians of the Kaspmoreneftegasprom VPO [All-Union Production Association], the Gipromorneftegaz Institute, and construction workers of the Kaspmoreneftegazstroy Trust.

The first such structure "weighed anchor" 2 years ago in the imeni 28 Aprelya Field. Its steel were planted 103 meters deep into the seafloor. After the first one, two more platforms were built. During this time, 11 high-yield slant-hole wells have been drilled from these artificial metallic islands by the cluster method. I want to give special mention here to the help provided to the Caspian oil workers by the associates of the AN UkSSR Arc Welding Institute imeni Ye. O. Paton. With their direct participation we were able to use advanced techniques in our welding operations. Such methods are extremely necessary when building such complicated metallic structures.

[Question] Kurban Abasovich, one would assume that the experience acquired during the construction of the first stationary rigs has made it possible to accelerate construction of subsequent structures?

[Answer] Absolutely. And I should say that today we are becoming aware of this. Today, at an accelerated pace, they are building a platform, designed for up to 120 meters of water. From this platform, and right in the very same imeni 28 Aprelya Field, 24 wells will be drilled. At the same time, work has begun on the erection of two more stationary rigs. Their operation in 1985 will bring about a sharp increase in oil recovery in the wide-open spaces of the Caspian.

12659
CSO: 1822/412

COAL

LAGGARDS, LEADERS IN DONBASS COAL MINING DESCRIBED

Kiev PRAVDA UKRAINY in Russian 18 Jul 84 p 1

[Article by N. Ladanovskiy, correspondent, Donetsk Oblast: "The Miners of Donetskugol' Are in the Lead"]

[Excerpts] From the Donetskugol' Production Association's socialist obligations, as published in PRAVDA UKRAINY on 8 January 1984: To fulfill the year's coal extraction plan ahead of schedule, on 26 December 1984 and to send at least 300,000 t of above-plan coal to the surface. To exceed the level set for labor productivity by at least 1.5 percent and reduce the cost of extracted coal by an addition 0.5 percent. To have 42 highly productive crews, including 12 that are extracting 1,000 t of coal or more per day from the working face, and 20 high-speed cutting crews.

From the Makeyevugol' Production Association collective's socialist obligations for 1984: To extract 120,000 t of above-plan coal during the year. On the basis of the introduction of new equipment and technology, progressive methods for organizing labor and production, and a strengthening of planning and labor discipline, to exceed the assignment for increasing labor productivity by 1 percent and reduce the cost of extracted fuel by an additional 0.5 percent. For the association as a whole, to raise the average daily production load to 443 t of coal, and to have at work at all times 7 integratedly mechanized crews that are extracting 1,000 t of coal or more per day from the working face.

In this five-year plan, the miners of the Donetskugol' Association are distinguishing themselves by the enviable stability of their work. Recently, as was reported by PRAVDA UKRAINY, they achieved a great labor victory: they sent to the surface their third million ton of above-plan coal since the beginning of the five-year plan. The miners are also confidently increasing their rate of extraction this year. During the first half of the year, they extracted 790,000 t of coal in addition to the plan. Labor productivity exceeded the planned level by 3.8 percent and output cost was reduced below the planned figure by 2.6 percent.

The association collective's main reserve was in increasing the effectiveness of the utilization of mechanized complexes and increasing the production load. Here about 50 percent of the coal comes from "iron" longwalls. The course taken was to achieve a standard load from all of them. What is happening, however, is that 1,000 t or more of coal is being taken every day from 12 longwalls, and that 10 extraction complexes have passed the 500-t mark in the daily extraction of coal from very thin beds.

In the association there are 20 cutting collectives that are working at high speed every month: their average monthly figure for cutting underground main shafts is 200-300 running meters. The result of this is that during the first 6 months of the year, about 7 km of above-plan developmental workings were cut, including 4.2 km of stripping and preparatory workings. This made it possible to start working an additional 11 longwalls, and all the mines have been provided with a reliable reserve of working fronts.

Good results were also achieved during the first 6 months by the miners of the Makeyevugol' Association, their long-time competitive rivals. True, their successes were a little more modest: 65,700 t of above-plan coal was extracted and labor productivity exceeded the planned figure by 0.4 percent. Their average daily production load was set at 443 t, but the miners managed to raise it to 446 t of coal.

One of the decisive factors in the efficient functioning of most extraction sections is the maintenance of the underground workings in good condition. In the association the course was taken to prepare the faces using progressive, pillarless technology, which makes it possible to reduce significantly the extent of the underground workings and reduce the labor and material expenses for the extraction of coal. Propaganda concerning progressive experience is given considerable attention here.

"After the example of our neighbors, we have organized a permanent School for Progressive Experience," says the association's general director, A.S. Chumak. "The attendees listen to specialists and scientists from branch institutes. In addition to theoretical lessons, there are also practical ones that are conducted right at the working positions. The development of the crew form of labor organization is yet another reserve. All of the workers in the extraction and cutting sections have now been combined into crews."

"If we consider the matter as a whole, then the Makeyev miners are dealing with fulfilling their obligations pretty well," notes L.I. Modulín, deputy director of the Ukrainian SSR Ministry of the Coal Industry's Technological Administration for Underground and Open-Pit Coal Extraction Methods, "but everything is far from having been done. During the first half of the year four mines--iméni Batov, iméni Pochenkov, iméni XXV s"yezda CPSU and Chaykino--did not meet the plan. It was planned for seven working faces to be brought into the 1,000-t-per-day mode. In all, however, only four longwalls were complexly mechanized."

The ministry thinks that the association's management--primarily General Director A.S. Chumak--meets frequently with the lagging mines' leaders, who explain the prolonged nonfulfillment of the plan with various "objective"

reasons. However, the situation is not like that, since organizational and educational work is a weak area. It should also be said that the style and methods of the association's central administration does not meet today's requirements. Many supervisory workers in the association's administration require much information and many reports from the mines, as before, but have little concern for organizing the production process at the working places. The leaders at the mines complain that they sometimes receive redundant and even contradictory instructions from the association. Not all of the association's specialists picture their duties clearly, because of which the working face line is not prepared on a timely basis at a number of mines and--and this is the most important thing--there is no reliable working face reserve.

To use the experience of our neighbors--the Donetsk miners--in full is the pledge for future success of the Makeyevugol' Association's miners.

11746
CSO: 1822/409

COAL

FURTHER DEVELOPMENT OF DONBASS MINES URGED

Moscow TRUD in Russian 10 Jun 84 p 2

[Article by A. Dokukin, corresponding member, USSR Academy of Sciences; director, Institute of Mining imeni A.A. Skochinskiy: "The Donets Stokehole's Tomorrow"]

[Text] Power engineering needs coal...a lot of coal. Today it is the basic fuel for both small boiler rooms and powerful heat and electric power plants. Even those of them that burn oil and gas in their furnaces are gradually being converted to coal. Indeed, how long can we let this most valuable raw material literally go "up the chimney" when, moreover, on the basis of the surveyed reserves, our reserves of it are of an order of magnitude less than those of solid fuel?

Of course, we would also like to find a better use for it. But what will replace it? Hydraulic power is not all-powerful, atomic electric power plants are still at the stage of an infant learning to walk, and the so-called "alternative" energy sources (the sun, the wind, waves, thermal waters) have not yet been developed. Coal is cheap and, like it or not, for the present we are burning it.

True, the statement about cheapness needs some substantial reservations. If coal has to be shipped great distances, its price rises sharply. Although this is sometimes justified economically, it is truly converted into "black gold"! This is why heat and electric power plants are, as a rule, built not far from extraction enterprises. Let us say here that power engineering in Western Siberia depends largely on the pit coals of Ekibastuz and the brown coals from the Kansk-Achinsk basin, which are being worked by the cheapest, open-pit method.

It is the same in the European part of the country, where there have long been relationships between the producers of electricity and the miners of the Donets basin. Many power plants were designed to use its energy-producing pit coals and its unique anthracites that are found nowhere else; the furnace elements of power-producing units have been planned with due consideration for their specific properties: heating value, tendency toward slag formation and so on. Conversion to a new type of fuel would require large expenditures to remodel the boilers.

This is why, in contrast to Siberia, the situation that has now arisen in the Donbass cannot but disturb economists and scientists. I have in mind the reduction in the scales of extraction of solid fuel. It has fallen from 223.7 million t--the maximum, achieved in 1976--to 200.1 million t in 1982, which is a decrease of 11 percent. The extraction of valuable coking coals has decreased to an even greater extent. And this happens even though additional capacities amounting to 42 million t of coal per year went into operation in the Donbass in the 1970's! If there had not been significant capital investments and production reserves that were created because of them, we would not even see the present level of extraction. Some people have even started talking about the fact, they say, that the basin is "unpromising" and that "its decline is not far off."

Is this so? I do not think so. According to the specialists' estimates, on 1 January 1982 the reserves of "black gold" for the construction of new mines was more than 8 billion t in the Donbass. To this it is necessary to add the more than 1.5 billion t that can be taken from longwalls that have already been driven by "cutting in," or enlarging the mine fields. This is completely sufficient to maintain coal extraction at its present level.

However, this can be done under only one condition: labor productivity for the basin as a whole must be increased. How? It is understood that natural riches just do not fall into one's hands by themselves. There is also little enthusiasm and self-sacrifice for this. Particularly in the Donbass, with its complicated geological and mining conditions: here the industrial reserves of coal are in beds less than 1.2 m thick, and more than half of these beds are sloping, with angles of incidence of up to 35°. Almost every third mine is 800 m or more deep. The help of scientists, machine builders and the representatives of other branches of the national economy is needed.

Specialists from the USSR Academy of Scientists and branch institutes have already done a great deal to solve the problems involved in struggling with high temperatures at great depths, mine pressure, degassing, mine shocks and sudden blowouts of coal, gas and rock. This made the people's work considerably more secure. Preliminary degasification of strata with a high gas content has been mastered in the Donbass, with the methane that is collected being used in mine and production boiler rooms. The widespread dissemination of this experience reveals an additional energy source. However, there is still not enough of it.

Modernization is of extreme importance for such a very old coal basin where most mines are more than 30 years old. It is being done not only to make a radical change in the very appearances of the mines, but also in order to achieve a significant improvement in the entire mine economy that has been built up. Modernization is a mandatory condition for further technical progress at the faces and will make people's work easier. However, much still remains to be done.

It is necessary to expand the use of conveyor transport, mechanized complexes at the working faces, and shaft-cutting combines. Scientific design work still lags behind the practical requirements in the area of the creation of

highly efficient, small, integrated mechanization facilities for working extremely thin beds (70-90 cm thick). This, in particular, resulted in the appearance in the Donbass of 200 longwalls being worked with prisechka [translation unknown] of the side rock, which causes the shipped coal's ash content to increase. The development of large-series production of the KM-103 mechanized complex at the Kamenskiy Soyuzuglemash plant will make it possible to reduce prisechka significantly (and possibly eliminate it entirely), create more favorable conditions, increase labor productivity at the working face, and improve the quality of the output. It is also necessary to speed up the creation of the KMT complex for ceilings that are difficult to control and expand the use of plane-type extraction, particularly with mechanized timbering. It is possible to continue listing the assignments of the individual ministries and departments for a long time, but our single final purpose is to remove people from the most difficult sections where up until now they have had to work with a pick-hammer, and have machines and automatic units do the work. At the December (1983) Plenum of the CPSU Central Committee, Comrade Yu.V. Andropov formulated the task of facilitating an increase in labor productivity and turning decisively to the problems involved in raising the technical level of production and improving output quality. This task, in full measure, belongs to our scientists and the specialists in the scientific research and planning and designing organizations.

In our discussions about the future of the Donets Coal Basin, we--naturally--are guided by the numbers and present purely economic reasons. However, there is yet another aspect of the question, about which one cannot keep quiet. The Donbass is the oldest forge for qualified working personnel. The Stakhanov movement was born here. The glory of today's crews of "thousand-tonners" has also reached beyond the borders of our country. Mining dynasties have become a good tradition. On the buses traveling between Makeyevka, Yenakiyev and Donetsk, one frequently hears conversations about mechanization, the modernization of mines, the discovery of new deposits. The people--workers, technicians, engineers--are troubled: what about tomorrow? That is why hundreds and hundreds of them stand in the ranks of rationalizers and inventors. That is why the news of the surveying of the favorable Bogdanovskoye deposit in Voroshilovgrad Oblast, where the largest number of mines that are being worked out is, was received with such joy here. When planning the fate of the traditional working regions, the planning agencies must not forget this.

In his report at the 26th CPSU Congress, N.A. Tikhonov, chairman of the USSR Council of Ministers, said: "Our duty, no matter how great our reserves of natural resources may be, is to look constantly for more rational ways of extracting them and using them economically." Analyzing the technical status and technical and economic indicators of the work being done by the Donets mine, one reaches the conclusion that not nearly everything has been done to prolong their lives. And the first thing one thinks is that not only should capital investments for their development not be reduced, but also that they should be increased. These means will be returned a hundredfold.

11746
CSO: 1822/409

COAL

COMPLETION OF CONCENTRATION MILL IN YAKUTIA EXPECTED

Moscow SOVETSKAYA ROSSIYA in Russian 25 Jul 84 p 1

[Article by M. Morozov, Neryungri: "A Schedule Speeds Things Up"]

[Excerpts] The construction site, which is spread out on the slope of a hill, is visible from afar. I recall how the frameworks of the huge buildings grew before my very eyes and today, like gigantic ships in the taiga sea, they are already covered with metal panels. The installation of the production equipment and the pipelines, which are unique as far as their capacities are concerned, is going at full speed. Here in southern Yakutia, in the center of the first territorial production complex in the BAM [Baykal-Amur Main Line] zone, a concentration mill that will be capable of treating 9 million t of coking coal per year is being built. According to the commitments made by the workers of the RSFSR, this enterprise, which will be the largest in the branch, will go into operation in 1984.

The workers, who are trying not to lose even 1 hour of the summer light, which is particularly dear under the conditions encountered in the north, are now increasing the rate of construction of the concentration mill and are nearing the finish line. Actually, idle running of the equipment is now scheduled to begin in August and not in October, as was previously assumed.

"Without exaggerating, the entire country is taking part in the construction of the mill," says V. Bocharov, chief of the Yakutuglestroy Combine. "Products from more than 500 supplier plants have arrived at the site. There is also some disorder, of course."

Matters at the mill are not going badly now, but there is still cause for concern. During the first 6 months, more than 28 million rubles' worth of construction and installation work was done, which was 2 million rubles more than was planned. This, of course, makes people happy. However, if one evaluates the indicators from the viewpoint of the network schedule, by which all builders must be guided, some lagging can be seen. Basically, the laggards are subunits of USSR Minmontazhspetsstroy [Ministry of Installation and Special Construction Work] that are specialized installation organizations of the Dal'stal'konstruktsiya, Vostoksibsantekhmontazh and Dal'teploizolyatsiya trusts and a number of others. About 190 foundations including those under the passageways that connect the mill's buildings with

each other, have still not been finished. This delay can affect the rates of the work still to be done.

In order to eliminate this lagging, the construction site staff made a decision: all the work of the enterprises and organizations engaged in erecting the concentration mill is to be evaluated only on the basis of the fulfillment of assignments specified by the network schedule. The requirements of this document are rigorous, but can be fulfilled realistically because they are backed up by material resources. Everything that is needed for the successful completion of all the work is now at the construction site. It depends on the clearcut organization of labor. The miners at the Neryungri Open-Pit Mine must also make their contribution to the accelerated construction of the mill. In order to insure the extraction of the first tons of raw material for this new enterprise, in the second half of the year they must remove 41 million^m3 of overburden from the deposit.

11746
CSO: 1822/409

COAL

DEVELOPMENT OF NEW, POWERFUL EXCAVATOR DESCRIBED

Leningrad LENINGRADSKAYA PRAVDA in Russian 3 Jul 84 p 2

[Article from Leningrad Branch, Telegraph Agency of the Soviet Union: "For the Open-Pit Coal Mines in Siberia"]

[Text] Excavators from a new series will be in operation at the largest open-pit coal mines in Siberia and the Far East in the future. The manufacturing plan for this excavator was created by specialists from the Izhorskiy Plant imeni A.A. Zhdanov. These machines have a scoop volume of 15 m³, and they were designed on the basis of the 25-m³ "steel coal miners" that are now being produced. In one working cycle the EKG-15 will be capable of moving a load of up to 50 t.

An economic experiment that is being conducted to improve the wages of designers and technologists at the Izhorskiy Plant and a number of other large enterprises in Leningrad was of assistance in the efficient modernization of these machines. The experiment made it possible to stimulate the most active specialists (in the creative sense) on a larger scale: temporary raises in their official salaries, ranging from 20 to 160 rubles, were approved. The necessary facilities were freed after the departure from the enterprise's production planning subunits of people who left for other work after their work certifications revealed their low output.

The experiment helped the designing of the machine be undertaken in a new way. During the creation of the excavator, organizations using materiel with the Izhorskiy trademark were queried and suggestions on how to improve the reliability and fitness for work of these mining "Hercules" were gathered. During the design work, there was a unique competition for the best plan.

An analysis of what has been done shows that as far as its specifications are concerned, the new machine is on the output level of the leading excavator-building companies in the world and that it surpasses the best examples in a number of parameters. The weight of the new excavator's main drive has been reduced by 10 t and that of the main winch by 2.5 t. As a result, with more power than ever and an increased scoop capacity, this machine proved to be no heavier than earlier models.

In order to insure the most rapid possible realization of this innovation in metal, the specialists knew how to standardize many of the EKG-15's elements with parts from other series of excavators. The production of almost one-third of all the parts of this modernized machine did not require any new work.

COAL

UDC 658.562:622.33"1976/1982"(477)

WAYS FOR LOWERING ASH CONTENT OF COAL PRESENTED

Moscow UGOL' in Russian No 7, Jul 84 pp 20-24

[Article by S.Ya. Petrenko, A.I. Smirnov and A.A. Krivchenko, candidates of technical sciences, DonUGI [Donets Scientific Research Institute of Coal]: "Ways for Improving the Quality of Extracted Coal"]

[Text] In recent years the quality of the coal being extracted and shipped by many of the Ukrainian SSR Minugleprom's [Ministry of the Coal Industry] enterprises has been deteriorating. For the branch as a whole, from 1976 to 1983 the ash content of the extracted coal increased from 29.1 to 35.8 percent and that of the coal that was shipped increased from 18.1 to 19.6 percent. In the Krasnodonugol', Dobropol'yeugol', Torezantratsit, Selidovugol', Donbassantratsit, Pavlogradugol' and Ukrzapadugol' Associations, the ash content of the extracted coal reaches 40 percent. In a number of associations the ash content of the extracted coal exceeds the bed's ash content by 15 percent or more.

Basically, the operational ash content increased for the following reasons:

- by 3.1 percent because of the introduction of mechanized complexes under unfavorable geological and mining conditions;
- by 2.8 percent because of the increase in the number of longwalls with incursion of wall rock;
- by 1.8 percent because of deterioration of the geological and mining conditions;
- by 1.1 percent because of an increase in the bed's ash content as the result of the working of beds with substandard ash content;
- by 0.8 percent because of an increase in the amount of extraction done with narrow-wedge extraction equipment (from 85 to 91.1 percent);
- by 0.8 percent because of an increase in the amount of extraction done with mechanized complexes (from 47.3 to 67.7 percent);
- by 1.3 percent because of the contamination of coal from development faces.

The operational ash content increased a total of 11.7 percent, but when the measures implemented to improve the quality of the extracted coal are taken into consideration, the increase is only 6.7 percent.

The extensive use of narrow-wedge extraction equipment, including mechanized complexes, contributed to the significant increase in the extracted coal's ash

content. Research done by DonUGI established that the operational ash content of the coal in longwalls worked with narrow-wedge combines is 3-4 percent greater than that of the coal in longwalls worked with broad-wedge extraction equipment. In addition to this, it was established that each percentage point increase in coal extraction by narrow-wedge equipment causes an increase in its contamination with rock by an average of 0.12 percent. In connection with this, the increase in contamination with rock for longwalls supported by mechanized timbers is 3.3 percent greater than for longwalls with individual timbers. Let us mention here that in recent years the increase in the number of longwalls with mechanized complexes (an average of 4.5 percent per year) has taken place primarily because of the exploitation of beds with unstable enclosing rocks. In connection with this, the contamination of the coal with rock is greater than the average value by a factor of two or three, which results in an annual increase in the extracted coal's ash content of 0.2-0.5 percent.

Let us also mention that in the last 8 years the number of longwalls with prisechka of the wall rocks has increased by 28 percent, which has led to contamination of the coal with rock; that is, an increase in its operational ash content. At the present time, in beds thicker than 0.95 m there are 90 longwalls with prisechka of the wall rocks, which is not always justified, because in most cases the bed can be worked with existing extraction mechanisms without prisechka. The elimination of prisechki in these longwalls will make it possible to reduce the extracted coal's ash content by 0.8 percent for UkSSR Minugleprom as a whole. An increase in the underground workings' cross-sectional area also contributes to an increase in the ash content of the rock mass removed from the developmental workings.

At the present time the joint extraction and sending to the surface of coal and rock is being done at 1,251 development faces. Contamination of the coal with rock was 2.3 percent, and for the Dobropol'yeugol', Selidovugol' and Sverdlevantratsit Associations it was 7.1, 9.2 and 2.9 percent, respectively.

As a result of the conversion of many mines to the sending of the rock mass to the surface, retardation of the development and increase in capacities of these mines is being seen, because the coal lifts' carrying capacity was not designed for the carrying of rock to the surface. In addition, many concentration mills turned out to be overloaded, since their capacities were designed for a different raw material base. Therefore, one-third of the extracted coal is now reaching the consumers without concentration.

The opinion that has been formed that the quality of the coal should be improved by increasing the volume of concentration work cannot be regarded as unambiguous. The solution of this problem requires not only the building of new concentration mills, but also the extensive modernization of mines for the purpose of increasing the traffic capacities of the lifts, underground transport and surface complexes. All this results in large capital investments.

The quality of the coal should be improved because of the use of technology for extracting it that facilitates the reduction of the contamination of the coal with rock, with the rock being left in the mine wherever possible. In

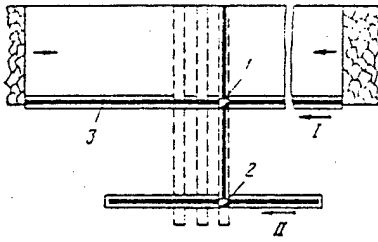

Figure 1. Process flow diagram of separate removal of coal from longwalls and rock from developmental workings, using permanent (mine) bunkers: 1, 2. bunkers for storage of coal and rock, respectively; 3. belt conveyor; I, II. direction of transportation to bunkers of coal and rock, respectively.

the covering being torn away from the ceiling. The use of these complexes will insure a reduction in the ash content of extracted coal of approximately 3 percent.

The UST-2M and SO-75 planers, which are in production, are used to extract coal from beds with a minimum thickness of 0.55 m.

At the present time, up to 150 longwalls that are 0.55-0.75 m thick can be equipped with these planers. In 1983 the average active number of all faces with plane-type extraction was 88, from which 8.1 million t of coal were extracted. In the future it will be necessary to increase the volume of coal extraction by plane-type equipment, primarily from beds less than 0.9 m thick.

During the extraction of coal from longwalls with unstable ceiling rocks, the ash content of the rock mass increases by 5.9 percent for UkSSR Minugleprom as a whole. The most efficient measures for the prevention of cave-ins of these rocks are the use of anchor and leading timbers, as well as strengthening synthetic resins. DonUGI has developed a method for strengthening rocks by chemical anchoring that is used extensively in the Donbass. In order to prevent cave-ins of loose rock or rock that is in small pieces, a technique and equipment for strengthening them by the injection of polyurethane reinforcing compounds have been developed.

Removal of the coal from the longwalls and the rock from the developmental workings at separate times contributes to an improvement in the quality of the extracted coal. In order to do this it is possible to use permanent (mine) bunkers, or temporary storage spaces in the form of mechanized bunkers or bunker trains. Figure 1 is a process flow diagram of the separate removal of coal from longwalls and rock from developmental workings, using permanent (mine) bunkers. At the present time, 110 permanent bunkers with a total capacity of 14,850 m³ are being used in UkSSR Minugleprom's mines. However, this

order to solve the problem that has been formulated, it is necessary to create extraction equipment that is capable of working beds less than 0.9 m thick without prisechka of the wall rocks. Work is being done in this area. Series production of the KM-103 mechanized complex for working beds 0.75-0.95 m thick has been mastered. The KD-80 mechanized complex, for beds 0.8-1.05 m thick, has been built.

Significant contamination of the coal in longwalls worked with mechanized complexes takes place as the result of the spillage of shattered rock when timber sections are taken down and moved. Let us mention here that in the KM-103, KD-80 and KM-87UMA complexes, movement of timber sections takes place without

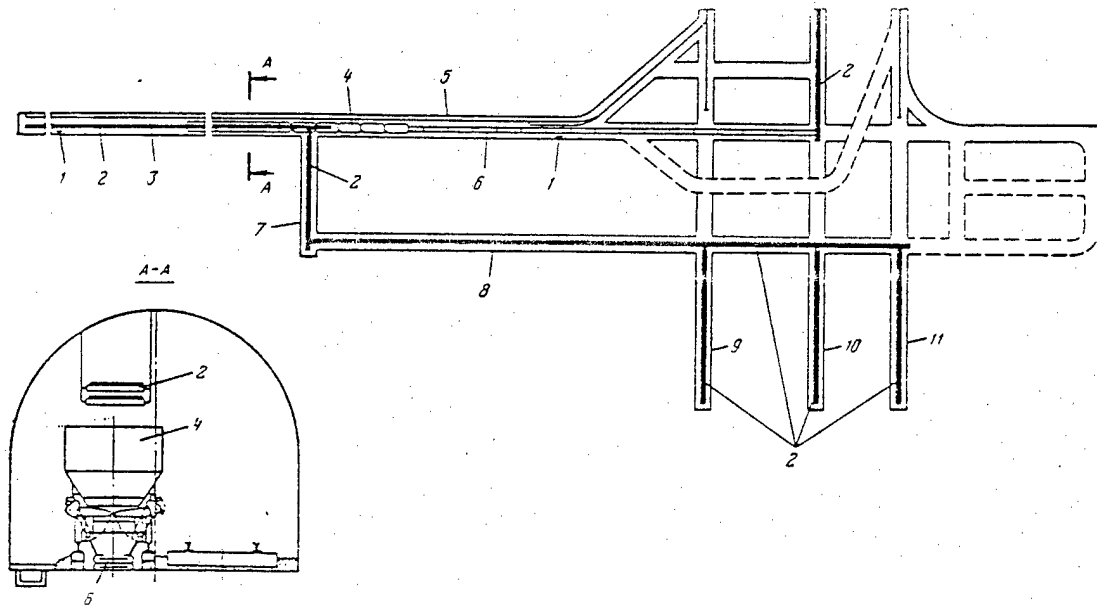

Figure 2. Process flow diagram of accumulation of rock from developmental workings and its separate removal, using a PS-3.5 sectioned train: 1. maneuvering crane; 2. belt conveyor; 3. track; 4. PS-3.5 sectioned train (VDK-2.5 cars); 5. conveyor drift; 6. SP-63 scraper conveyor; 7. conveyor passage; 8. combined conveyor drift; 9. cargo passage; 10. incline; 11. personnel passage.

level of bunker use does not make it possible to insure the separate removal of coal and rock everywhere.

For the purpose of insuring stable operation of the underground transport systems and improving the quality of the coal, from 1981 to 1983 DonUGI worked out process flow diagrams for the accumulation of coal and rock using a PS-3.5 sectional train (Figure 2). With the help of a maneuvering winch, the train moves and is loaded with rock. It is unloaded at a certain time when no coal is being transported along the main working. In order to do this, the PS-3.5 train is placed above a scraper conveyor that is located between the tracks and unloaded by opening the bottoms of the sections (VDK-2.5 cars).

The capacity of the storage bunkers is determined in each specific case and depends on the amount of rock to be removed and the time allocated for its transportation.

The table on the next page gives the necessary capacities of permanent (mine) bunkers as a function of the cross-sectional area of a working, the rate at which the working is being driven, and the organization of the removal of the rock from the working.

The production method utilizing mechanized bunkers underwent industrial testing at the Krasnoarmeyskugol' Association's mines. The rock was removed three times a day, during 1 hour of each shift. In connection with this, the rates

Площадь сече- ния выработки в сечу, м ² (1)	Вместимость, м ³ , постоянных (горных) бункеров при скорости проведения выработки, м/мес (2)									
	50	75	100	125	150	200	225	250	275	300
	при выдаче породы один раз в сутки (3)					при выдаче породы два раза в сутки (4)				
7	60	80	110	140	160	110	120	140	150	160
9	70	110	140	180	210	140	160	180	190	210
10	80	120	150	190	230	140	170	190	210	230
13	100	150	200	250	300	200	230	250	280	300
15	120	170	230	290	350	230	260	290	320	350
20	160	230	310	390	470	310	350	390	430	470

Key:

1. Inside cross-sectional area of working, m²
2. Capacity, m³, of permanent (mine) bunkers for rate of driving of working, m per month
3. For rock removal once a day
4. For rock removal two times a day

of horizontal and sloping airways and conveyor workings with inside cross-sectional areas of 6-18 m² (by daylight) behind the longwall face in beds 0.7-1.5 m. thick. The length of inclination is 10-40 m, and the speed of workings driven up to 90m/mo.

Titan-1 complexes are used during ventilated, conveyor and coupled workings with inside cross-sectional areas of more than 8.5 m² (by daylight) in beds more than 0.5 m thick, in rock with compression strength of up to 80 MPa, when the material to be dumped is to be transported up to 80 m. At the present time, 37 "Titan-1" complexes are in operation at UkSSR Minugleprom's mines. The complex's operational productivity is 6-10 m³/h, which is greater by a factor of 2-2.5 than that of the ZU-1 scraper-type dumping units. In connection with this, as the result of the denser packing done by the complex in comparison with the packing done by the ZU-1 units, the convergence of the ceiling to the floor is reduced by a factor of 1.5-2, which contributes to reducing the coal's contamination by the enclosing rocks when they are recovered.

On the basis of the experience gained in using the "Titan-1" complexes, the area of their effective utilization has been established. It is advisable to use the complexes:

- during the driving of haulage drifts with the longwall face in advance;
- during the driving of workings behind the longwall in the case of bottom blasting of the rock;
- during the driving of workings behind the longwall with top blasting, under conditions of nonsoaking rocks, with a cross-sectional area of the workings of 11-14 m² (in the cutting) and a longwall driving rate of more than 50-60 m per month, as well as with a cross-sectional area of the workings of 10-15 m² (in the cutting) and a longwall advance rate of more than 30-40 m per month.

In all other cases it is more realistic to use scraper-type dumping units. In UkSSR Minugleprom's mines it is possible to use about 150 "Titan-1" complexes,

at which the workings were driven reached 250 m per month and the ash content of the coal extracted at the mine dropped by 1.5-2 percent.

As has already been mentioned, when the rock is left in the mine and placed in spaces that have already been worked out, the quality of the extracted coal improves. The problems related to the development of the technology for creating our own storage facilities for the sloping beds found in the Donbass have already been solved.

Every year about 280 km of workings are driven by UkSSR Minugleprom's enterprises and then filled with rock. The placement of the rock is carried out with ZU-1 units (about 60 percent of the workings that are driven) and "Titan-1" pulverizing complexes (4 percent). The ZU-1 units are used during the driving

which will make it possible to leave up to 4.9 million t of rock in the mines and reduce the operational ash content by 1 percent.

DonUGI, together with Dongiprouglemash [Donetsk State Design-Development and Experimental Institute for Coal-Related Machinebuilding] and the Shakhterskantratsit Association, has developed the technology for dumping rock in the longwall. This method has been used in the Shakhterskantratsit Association's Komsomolets Donbassa Mine and the Krasnoarmeyskugol' Association's Mine imeni A.G. Stakhanov. Specially built pulverizing and dumping complexes are being used in both cases. The dumping of the rock at the Komsomolets Donbassa Mine resulted in practically repairfree maintenance of the extraction section's side workings. This not only averted contamination of the coal because of rebracing, but also facilitated the repeated use of the workings.

The use of stationary dumping complexes to leave the rock in the mine can be utilized at approximately 55 of UkSSR Minugleprom's mines.

DonUGI has developed an experimental prototype of a unit for removing rock from rock mass of class +100 mm on the basis of its natural radioactivity. The use of this unit at mines in the Donbass will make it possible to reduce the yearly volume of rock that is moved and the load on the concentration mills by 5 million t.

An integrated system for controlling output quality (KS UKP) is being introduced in UkSSR Minugleprom's enterprises. On the basis of standardization, this system makes it possible to regulate the requirements for the quality of the extracted coal. DonUGI has developed standard techniques, branch standards, plans for the leading technical materials, and enterprise standards for the functioning of the KS UKP at the mine and association level. At the enterprises that use this system the quality of the coal has been stabilized, and at the Torezantratsit Association's Progress Mine the ash content of the shipped coal is 0.1 percent lower than the norm.

Effective technical monitoring at the mines is of great value for improving the quality of the extracted coal. DonUGI, together with the IGD [Institute of Mining] imeni A.A. Skochinskiy, has developed the EAZ rapid ash content analyzer. The EAZ equipment is used extensively at mines in the Donbass. Using the EAZ, the ash content in coal in lumps 0-50 mm in size can be determined in 5 min with an absolute error of ± 1 percent. There are also the AZUK coal ash content analyzers, which make it possible to determine the ash content in lumps 0-100 mm in size directly on the conveyor, with an absolute error of ± 1 percent in the 5-50 percent range. Three sets of this equipment are being used at the Donetskugol' Associations Mines imeni A.A. Skochinskiy and imeni Ye.T. Abakumov.

DonUGI is developing a section ash meter that will give hourly information on the quality of coal arriving from a longwall. Work is being completed on the creation of the SKZ coal ash content monitoring system, which is based on a fundamentally new principle that utilizes a microcomputer. Thus, the mines will receive an automated system for monitoring the quality of the extracted coal.

The methods for improving coal quality that are listed above are the most effective ones, but their realization will require a significant amount of time. Therefore, it is necessary that the associations annually develop and introduce organizational and technical measures that will make it possible to retard the deterioration in the quality of the coal that is being extracted. For 1983-1985, DonUGI has developed measures for 7 open pit mines and 241 mines and mine administrations. Their implementation will make it possible to reduce the operational ash content for UkSSR Minugleprom by 1.7 percent and thereby compensate for the increase in contamination of coal by the enclosing rocks because of unfavorable factors.

It is necessary for the mines to make appropriate decisions the limit the taking into account of coal extracted with an ash content that exceeds the established norms. In addition, at the mines it is necessary to increase mental and material interest in improving the quality of the extracted coal. Thus, the problem of improving the quality of the extracted coal can also be solved at the mine level by making the appropriate technical and production decisions and increasing the interest in and responsibility for this important national economic indicator.

COPYRIGHT: IZDATEL'STVO "NEDRA," "UGOL," 1984

11746
CSO: 1822/410

COAL

UDC 658.5:622.33.012 "Karagandavgol'"

IMPROVEMENTS IN LABOR DISCIPLINE IN KARAGANDAUGOL' DESCRIBED

Moscow UGOL' in Russian No 7, Jul 84 pp 4-6

[Article by N.A. Drizhd, general director, Karagandaugol' Association: "To Strengthen Labor Discipline and Improve the Organization of Production"]

[Excerpts] The Karaganda Coal Basin underwent further development during the 11th Five-Year Plan. The basic production reserves were and remain the efficient use of labor resources, the strengthening of labor and production discipline in every way possible, good organization of the work, and a radical improvement in the status of accident prevention and production sanitation.

The workers in the basin received with enthusiasm the party's instructions about strengthening labor, planning and state discipline. General working meetings were held in all the labor collectives, with the participation of the association's directors and other responsible workers, on the theme "On the Status of and Measures for Strengthening Labor and Production Discipline and Improving Accident Prevention." This question was discussed by 87,000 workers, and more than 500 people spoke, including 350 workers. About 100 suggestions were made, aimed at strengthening labor discipline, eliminating idle time and accidents, and making more effective use of working time. All of those who spoke demanded unanimously the adoption of decisive measures toward those who do not value the honor of their own labor collective and the interests of the production process.

This comprehensive discussion and the subsequent adoption of effective measures made it possible to raise the level of extraction at mines that were previously laggards: Kazakhstanskaya, Maykudukskaya, Sokurskaya, Saranskaya and the Mine imeni Kalinin.

It is noteworthy that at the Kazakhstanskaya Mine in 1983, in comparison with 1982, the number of workers who were truant was cut in half and the losses of working time for the same period was reduced by a factor of more than two. However, the status of labor discipline and the work indicators at this enterprise are still not at the necessary level, and work to improve them continues.

In order to further strengthen labor discipline and law and order, the association's leadership and the Karaganda Terkom [probably Territorial Committee] of the Trade Union of Coal Industry Workers adopted a joint resolution in

March 1983. At the same time, they worked out integrated measures for strengthening labor discipline and reducing working time losses at the mines and enterprises and in the organizations of the Karagandaugol' Association for the 1983-1985 period that provide for an annual reduction in the number of truant workers of at least 3 percent, a reduction in working time losses because of labor discipline violations of 5 percent, a reduction in worker turnover of 0.2 percent, an improvement in labor and leisure conditions that will cause a reduction in working day losses because of illness of 1 percent, and others.

A staff for the efficient utilization of working time and labor resources has been established in the association for the purpose of organizing the work and monitoring the implementation of the integrated measures on a daily basis. Every Friday there are selective meetings for the operational solution of practical problems. The staff reports to the association's general director about its work.

The staff has correlated documents concerning labor legislation and prepared recommendations for reducing working time losses that have been distributed to all enterprises. It has also developed a daily report form that describes the enterprises' personnel strength for the basic professions and production processes in comparison with the corresponding periods for the previous month and year. Analogous information also reflects the utilization of calendar working time used for both the extraction of coal (including the allocation of time by shifts) and preparatory and repair work. This reporting form provides a capability for the timely solution of problems involving the efficient utilization of labor resources.

An analysis of the utilization of working time shows that the best results are achieved by the leading collectives of the extraction sections that are competing for the extraction of 500,000 t or more of coal per year and 1,000 t or more per day from a single longwall, as well as cutting crews that are struggling to drive underground workings as rapidly as possible.

Notable success was achieved by the collective of Extraction Section No 3 from Shakhtinskaya Mine, which is led by N.I. Gladkikh and extracted its millionth ton of coal on 26 December 1983. Extraction productivity per worker was 627 t per month, and the crew's labor productivity plan was overfulfilled by 27.2 percent.

The same success was achieved by V.I. Litvinov's Section No 1 from the Mine imeni Kostenko. Both these collectives are notable for their high discipline and clearcut organization of labor.

The cutting crew of Kazakh SSR State Prize laureate V.N. Zavedeyev, from the Molodezhnaya Mine, drove 5,138 m of underground workings in 1983, as opposed to its assumed obligation of 5,000 m. This, also, was the result of the clearcut, harmonious work of the entire collective. The crew has been working for a long time without a single violation of labor discipline.

For the association as a whole, 106 mine, section and crew collectives reported the fulfillment of their plans for the first 3 years of the five-year plan

ahead of schedule, and the Karagandugol' Association completed its own 3-year program on 23 December 1983. The total amount of coal extracted was 146 million t, of which 1.24 million t was above-plan output.

Good results in the matter of strengthening labor discipline were achieved by the collectives of the Mines imeni Kostenko, imeni Gorbachev and imeni T. Kuzembayev and the Molodezhnaya and Tentekskaya Mines. For the association as a whole, working time losses because of violations of labor discipline were reduced by 30 percent.

There was an improvement in the work being done by the comrades' courts, the personnel social sections, the crew chief and mining foreman councils, the PDPS [Standing Production Conference] and other public organizations.

The association's leadership attaches great importance to the training and retraining of working personnel. For instance, it was stipulated that the plan for retraining and training in allied professions was to encompass 8,400 people in 1983. Actually, 10,970 specialists were trained and 18,359 workers had their qualifications improved, as opposed to the planned figure of 15,

Last year a great deal of attention was devoted to the training of cutters (1,747 people were trained). During the first 3 years of the 11th Five-Year Plan, 4,000 workers have mastered this profession.

Tutoring was and remains an important means for the communist education of young people. The practice of this excellent movement is constantly being improved and enriched. At the present time there are 5,371 tutors in the association, of whom 972 are communists and about 500 are Komsomol members. There are 12,852 young miners who are 24 or younger and who are working and acquiring professional skills under the leadership of experienced working personnel. Collective forms of tutoring received further development. At a number of mines, those being assisted and their tutors are assuming joint obligations and holding meetings and leisure evenings together.

The collective at the Dolinskaya Mine was the first in the basin to assume socialist obligations to increase labor productivity by 1 percent and reduce production output cost by 0.5 percent. All the collectives in the association followed its example.

Party, trade union and Komsomol organizations are actively participating in strengthening labor discipline in the basin's enterprises. All this great and critical work is being directed and organized by the oblast, city and rayon committees of the CP Kazakhstan, under the leadership of which the many thousands of members of the Karagandugol' Association's collective are successfully fulfilling their assignments for the 11th Five-Year Plan.

COPYRIGHT: IZTADEL'STVO "NEDRA," "UGOL", 1984

11746

CSO: 1822/410

COAL

UDC 658.588.8:622.33.012.3 "Krasnoyarskugol'"

PLANS FOR CONSTRUCTION OF FUEL COMPLEX REPAIR BASE DISCUSSED

Moscow UGOL' in Russian No 7, Jul 84 pp 30-31

[Article by V.V. Andreyev, engineer, Uralgiproshakht [Ural State Institute for the Planning of Mines]: "An Improved Repair Base for KATEK"]

[Text] The development of the Kansk-Achinsk fuel and energy complex (KATEK) provides for the use of complicated, highly productive equipment: rotor complexes with a productivity level of up to 12,500 t/h that are equipped with pulverizing units and reloaders, powerful spreaders and conveyors, cyclic-action excavators with scoops holding 40-100 m³, diesel locomotives and dump cars and others. All this complicated and expensive equipment requires timely and high-quality maintenance and repair.

The Krasnoyarskugol' Association's repair base includes maintenance shops for open-pit mines, two mechanical repair plants and central electromechanical shops with a total annual capacity of 8.6 million rubles.

The plan for the development and siting of KATEK's repair bases provides for the renovation of three existing repair enterprises: the Irsha-Borodino and Nazarovo Mechanical Repair Plants and the Chernogorsk Electromechanical Shops, plus the construction of new enterprises in the city of Sharypovo: plants for the repair of overburden removal and transportation equipment and machines that are expensive to build, as well as a motor vehicle repair plant.

It is advisable to locate the new repair enterprises in a single industrial complex and to combine them into a single industrial area with common utilities so that they can cooperate in obtaining castings, stampings, plastic and rubber goods, tools, special transportation and thermal energy from the main plant for the repair of mining and transportation equipment. This will make it possible to achieve a significant reduction in the total capital investments for the construction of KATEK's repair base, the projected cost of which is 300 million rubles.

An analysis of the functioning of the existing repair enterprises shows that their productive capacities are inadequate and that the construction of new repair plants has not yet begun. Every year there is a decrease in the deliveries of spare parts by producer plants.

At the present time the repair enterprises and open-pit services are incapable of making up for the shortage of spare parts. As a result, the dates for preventive maintenance and capital repairs are not met and worn-out parts and elements are not replaced on a timely basis, which entails premature deterioration of the equipment and reduces the effectiveness with which it is used. Therefore, supplying the open-pit mines and repair enterprises with spare parts is of extreme importance in the organization and technology of the performance of repair work.

This problem can be solved by increasing the production of spare parts at the producer plants, since the repair enterprises themselves are incapable of providing for the production of the entire list of parts. It is necessary that the machine-building plants producing machines and equipment for open-pit work support their maintenance and repair, as well as the centralized provision of spare parts.

The organizational structure of maintenance and repair must undergo some serious changes. The repair of large-scale mining equipment with large unit capacities (excavators, spreaders, pulverizing units, main conveyor belts and others) that is being used in continuous-action complexes should be done only by the aggregate element method, without stopping for capital repair.

Under the conditions present in Krasnoyarsk Kray this will make it possible to use equipment more rationally, distribute repairs more evenly over the course of the year, and--when necessary--shift the dates for the performance of repair work to the winter period and combine repair work with equipment idle time that is forced because of unfavorable weather conditions.

The aggregate element method consists of replacing assembly units with new ones or ones that have been previously repaired under plant conditions, for which a turnover stock of elements and assemblies from newly acquired and reconditioned old ones must be created at the repair enterprises.

It is necessary to equip open-pit mines and repair enterprises with equipment for the performance of rigging and unrigging work, the transportation of heavy elements and units, and the mechanization of repair work. This equipment includes self-propelled cranes with a lifting capacity of up to 100 t, special tractors and truck trailers for the movement of large elements, hydraulic and mechanical lifts and jacks with various lifting capacities; equipment for dismantling and transporting conveyor belts, installations for creating and maintaining favorable working conditions in production areas when welding work is being done and conveyor belts are being vulcanized, mobile heating points and snack bars so that the workers can rest and eat when repair work is being done directly in open-pit mines during and winter, and other equipment.

Considering the concentration of KATEK's mining enterprises and the large amount of repair work being done, the plan for the development of its repair base provides for the creation of the KATEKugleremont [probably KATEK Mine Working Repair] Association at the main plant for the repair of mining and transportation equipment. In connection with the association, it is also advisable to create the following: an automated production control system; a design and

technological office for the development of the technological documentation for the repair and reconditioning of elements and parts; a mechanized base, equipped with the necessary special motor vehicle transport, for the performance of repair work under field conditions and the transportation of elements and assemblies to the repair plants.

The creation of a specialized repair association will make it possible to:
specialize the repair enterprises and repair work;
concentrate all the materials and spare parts in one place;
make more effective use of the repair enterprises' production equipment and partially reduce the amount of it;
improve the maintenance personnel's qualifications and the quality of the repair work that is done;
free the open-pit mines from the performance of auxiliary repair work, so that their activities can be directed at the rhythmic fulfillment of the coal extraction plan;
partially reduce the number of maintenance personnel engaged in repair work.

Capital construction--the introduction of new areas and objects at existing repair enterprises and the construction of new ones--is of extreme importance for the development of the repair base.

The construction of the repair base must be planned simultaneously with the construction of the mining enterprises, and when open-pit mines are put into operation its development must be carried out at outstripping rates. Only this can guarantee the effective utilization of equipment and its stable, accidentfree operation.

COPYRIGHT: IZDATEL'STVO "NEDRA," "UGOL'", 1984

11746

CSO: 1822/410

COAL

BRIEFS

MINERS PLEDGE MILLION TONS--Karaganda--The miners of the Mine imeni Kostenko's First Section, led by V. Litvinov, have extracted more than half a million tons of fuel this year. By the end of the year they intend to produce more than 1 million t of coal--such is the commitment of these leaders. Every day the miners extract at least 3,000 t of fuel. [By V. Glotov] [Excerpts] [Moscow SOTSIALISTICHESKAYA INDUSTRIYA in Russian 25 Jul 84 p 1] 11746

KATEK'S RESOURCES, FUTURE DESCRIBED--KATEK is the Kansk-Achinsk Fuel and Energy Complex. The geological reserves in the basin are estimated at 600 billion t of coal. The beds lie at a shallow depth and one-fourth of them are suitable for mining by the open-pit method. The complex is being developed in three directions: the burning of coal right there for the generation of electricity and the production of enriched solid and liquid fuels. The Nazarovskaya GRES has already been built and is producing current, and the Berezovskaya GRES is soon to be in operation. The city of Sharypovo is growing. The construction of installations at which brown coal will be used to produce semicoke, tar and gas fuels is proceeding in the Krasnoyarskugol' Association. In the future there will be synthetic liquid fuel based on KATEK's coals. This goal was formulated by the 26th CPSU Congress. In essence, what is being discussed is the creation of a large new branch of the national economy. It is conjectured that the capacity of the artificial liquid fuel plants will be 10-15 million t. Thus, 8-10 plants will be located in the central part of Siberia in the future. This assignment is a complex one, and the plans are not to complete it during a single five-year plan. The party's Central Committee is obliging the Komsomol organizations to increase their contribution to the realization of the plans for economic, social and cultural construction. KATEK needs the skilled hands, daring minds and labor enthusiasm of young people. [Text] [Moscow KOMSOMOL'SKAYA PRAVDA in Russian 11 Jul 84 p 2] 11746

FIRST YAKUT COAL MINE--Neryungri, Yakut ASSR 18 [Jul]--The site has been chosen for the Denisovskaya Mine, the first in Southern Yakutia. It has been decided to build it about 20 km away from the city of Neryungri. The Denisovskaya's miners will extract 1.8 million t of high-quality coking coal every year. The construction of a concentration mill is also planned. [By V. Yermolayev] [Text] [Moscow PRAVDA in Russian 19 Jul 84 p 1] 11746

ABOVE PLAN NEAR MOSCOW--Tula--Since the beginning of the year, the 10 mines in the Moscow basin have managed to get 2 weeks ahead of the production schedule.

As a result of the intelligent use of mining technology and the efficient organization of labor, the basin's miners will realize more than 550,000 t of fuel more than their assignment. [By V. Pavlov] [Excerpts] [Moscow SOTSIALISTICHESKAYA INDUSTRIYA in Russian 21 Jul 84 p 1] 11746

ABOVE PLAN NEAR URALS--Korkino, Chelyabinsk Oblast--Since the beginning of the year, the miners at the Korkinskiy Open-Pit Mine have extracted 200,000 t of coal more than was assigned. This is greater by a factor of 1.5 than the obligation they assumed for the year. In connection with this, there has been significant overfulfillment of the assignment for increasing labor productivity and reducing output production cost. This alone made it possible to save more than 600,000 rubles. The Ural miners achieved this weighty success thanks to the development, following the example of the Donetsk, of a competition with the slogan "The Five-Year Plan--to the 50th Anniversary of the Stakhanov Movement!" Using its internal reserves, during the 11th Five-Year Plan this leading collective has 3 times been awarded the Challenge Red Banner of the CPSU Central Committee, the USSR Council of Ministers, the AUCCTU and the All-Union Komsomol and has had its name entered on the All-Union Board of Honor at the USSR Exhibition of Achievements of the National Economy. An example of the selfless labor being done at the Korkinskiy is the collectives of the sections led by A. Stepanchenko and V. Kretov. [By V. Zenkovskiy] [Text] [Moscow SOTSIALISTICHESKAYA INDUSTRIYA in Russian 13 Jul 84 p 1] 11746

MILLION-TONNERS ON THE DON--Rostov-na-Donu--Following the renowned mining crews of two-time Hero of Socialist Labor Mikhail Chikh and Hero of Socialist Labor K. Markelov, Viktor Frolov's crew at the Mine imeni 60-letiyе Leninskogo Komsomola has sent half a million tons of coal to the surface since the beginning of the year. This means that yet another, third mining collective in the Donbass is working in a mode to extract 1 million t of coal in a year. The equipment at the longwall is good: a KMK-97 mechanized complex with an SN-75 plane from the Shakhty Machine-Building Plant. The bed is a thin one that is not easy to work. While they were adapting themselves to the sloping field, they sent 1,000-1,500 t of anthracite per day to the surface. Right now, the daily production load reaches 3,000 t on some days. From the beginning of the year it has averaged 2,747 t. [by V. Uzhakin] [Excerpts] [Moscow SOTSIALISTICHESKAYA INDUSTRIYA in Russian 10 Jul 84 p 1] 11746

ABOVE PLAN IN KRASNODON--Krasnodon--On the chunk of coal the smiling miners are holding in their hands, the number 2,575,000 is written in white paint. Having extracted this many tons of fuel, the crew of working face workers led by Hero of Socialist Labor A. Kolesnikov managed to fulfill its plan for the first 4 years of the five-year plan ahead of schedule. In connection with this, more than 400,000 t of valuable coking coal more than was scheduled has been sent to the consumers. The collective of the Krasnodonugol' Production Association's Molodogvardeyskaya Mine proudly congratulated the extraction workers for their labor victory. The tense duel with the elements lasted for more than a month. And the miners emerged from it as the victors. The coal extraction losses turned out to be much smaller than those that would have resulted from a "flanking maneuver." The crew's tempo gained speed from month to month. Right now it is entering 200 t and more of fuel to its above-plan account every day. [By V. Mikhaylichenko] [Excerpts] [Moscow SOTSIALISTICHESKAYA INDUSTRIYA in Russian 7 Jul 84 p 1] 11746

KUZBASS COAL PIPELINE GROWING--Novosibirsk--The collective of the Novosibirsktruboprovodstroy [not further identified] trust's Administration No 2 has started to assemble the third 10 km of the steel riverbed over which fuel extracted by Kuzbass [Kuznetsk Coal Basin] miners from the Inskaya Mine, which is not far from the city of Belovo, will flow directly into the furnaces of TETs-5 in Novosibirsk. When the largest hydraulic coal pipeline in our country, which will be 260 km long, is put into operation it will make it possible to free more than 50,000 railway cars per year for other needs. New engineering decisions and technical developments proposed by the scientists and specialists in the planning and design organizations are being used in the construction of this main line. By increasing the work rate, this important Siberian construction project has become a school for progressive organization and technical experience that will be used by the builders of future unique pipelines for the transfer of coal slurry over long distances. [By A. Lyakhov] [Text] [Moscow SOTSIALISTICHESKAYA INDUSTRIYA in Russian 18 Jul 84 p 2] 11746

'THIN-BED' MINING--Rostov-na-Donu--The miners in two-time Hero of Socialist Labor M. Chikh's crew, at the Rostovugol' Association's Mayskaya Mine, have begun to add coal to their account for the second half of the year. Yesterday they gave the country its 500,000th ton of anthracite since the beginning of the year. And although it is a well-known fact that there is no "easy" coal, the mark that was the normal one for this renowned mining collective in previous years was especially hard to reach. Under difficult mining and geological conditions, the crew is now working a so-called "thin" coalbed. A careful organization of labor and high personal responsibility for assigned tasks on the part of everyone enabled this progressive collective to achieve a maximum reduction of losses and double equipment operating time in comparison with other analogous longwalls. [Text] [Moscow SEL'SKAYA ZHIZN' in Russian 27 Jun 84 p 1] 11746

ABOVE PLAN IN VORKUTA--Vorkuta--Since the beginning of the year, the miners of the Vorkutaugol' Association have sent a half-million above-plan tons of coal to the surface. This is the most significant achievement of these polar miners in this five-year plan. It was born in the fire of a competition that was developed at the mines in honor of the 40th anniversary of the Victory and the 50th anniversary of the Stakhanov Movement. There were fewer lagging collectives and more leading ones. The collective of the giant Vorgashorskaya Mine is confidently leading the competition. [By V. Krukovskiy] [Text] [Moscow SOTSIALISTICHESKAYA INDUSTRIYA in Russian 20 Jul 84 p 1] 11746

STAKHANOVITES IN EKIBASTUZ--Ekibastuz--The miners of Ekibastuz have joined in a socialist competition for a worthy greeting to the 50th anniversary of the Stakhanov Movement. On the initiative of Gennadiy Kisalev's rotary extraction complex crew, a shock watch under the slogan "50 Shock Weeks--To the Stakhanov Jubilee!" has begun at the Bogatyr' mine, which is the largest open-pit mine in the world. In the 4th year of the five-year plan, this leading collective has already extracted more than half a million tons of cheap above-plan coal. Success is also being achieved by the Young Komsomol excavating crew led by USSR State Prize laureate Anatoliy Shishlov, to whose above-plan account 300,000 t of coal have been credited. The excavators led by Sergey Zubko are

working ahead of schedule. Many mining collectives are counting on fulfilling their assignment for the 11th Five-Year Plan in August 1983, by the day of the 50th anniversary of Aleksey Stakhanov's record. [By A. Rogov] [Text] [Moscow SOTSIALISTICHESKAYA INDUSTRIYA in Russian 8 Jul 84 p 1] 11746

GEOTHERMAL POWER IN TRANSCARPATHIA--Transcarpathian Oblast--This is now the second year that geologists have carried out intensive drilling work in search of underground fuel in Beregovo Rayon. According to data obtained by scientists at the Ukrainian SSR Academy of Sciences' Institute of Technical Thermodynamics, the heat reserves concentrated in the area of the Transcarpathian Geothermal Anomaly are capable of giving off 5 billion t of conventional fuel. This is also the opinion of the specialists who have decided to develop a Transcarpathian geothermal TETs. The construction of this electric power plant will make it possible to generate almost the cheapest electricity there is. At the same time, environmental pollution will be completely eliminated. The water will be used several times, in a closed cycle. The representatives of the Ukrneft' Association's Dolina Drilling Administration have already achieved great successes. A borehole more than 4,200 m deep has been drilled. At that depth the rock temperature reaches more than 200 degrees of heat. The drilling of new boreholes lies ahead. [By I. Chopovdya] [Text] [Kiev RABOCHAYA GAZETA in Russian 6 Jun 84 p 2] 11746

ABOVE PLAN IN KRASNOYARSK--Chernogorsk--The collective at the Khakasskaya Mine, which is the Krasnoyarskugol' Association's leading enterprise, is now working under shock conditions. Having sent about 60,000 t of above-plan coal to the surface since the beginning of the year, the miners have "rounded off" their above-plan account for the five-year plan to 200,000 t. This is the result of a successfully implemented long-term program for improving labor productivity and reducing the cost of each ton of fuel. Having surpassed its labor productivity plan by 10.3 percent since the beginning of the year, the Khakasskaya's toilers achieved a record average monthly coal extraction rate per worker: 122 t, which is more than twice the average branch figure. The competition of the "thousand-tonners" led by Aleksandr Martynov and Petr Patrushev is gathering steam. Although the extraction of 1,000 t of coal per day from a single longwall was a record a few years ago, now it is the norm. Having mounted a shock watch in honor of the 50th anniversary of the Stakhanov movement, the Khakasskaya Mine's collective assumed the obligation of fulfilling its 5-year assignment by this notable date. [By V. Khrustalev] [Text] [Moscow SOTSIALISTICHESKAYA INDUSTRIYA in Russian 17 Jun 84 p 1] 11746

ABOVE PLAN IN TURKMENISTAN--"You give your word--you keep it." That is the working principle of Dardymamed Kerimov, an operator in the Turkmenneft' Association's Gas and Oil Extraction Administration imeni V.I. Lenin. Together with his comrades at the oil enterprise he is fulfilling his assumed socialist obligations successfully and has extracted about 3,000 t of above-plan fuel since the beginning of the year. D. Kerimov, an experienced master in his field, is generous in sharing his experience with young people. For his labor successes he has been awarded the order "Badge of Honor." The toilers at the Lebedino Mining and Concentration Combine also did well in the first half of the year. These miners are coping successfully with their obligations--more than 30,000 t of crude ore has been credited to their above-plan account.

They are also realizing one of the main points of their socialist obligations: increase labor productivity by 1 percent percent above the plan and reduce output cost by an additional 0.5 percent. [Text] [Moscow SOTSIALISTICHESKAYA INDUSTRIYA in Russian 6 Jul 84 p 2] 11746

NEW WORKING FACE COMPLEXES--Working face complexes of a new class will make it possible to work thin coalbeds under complicated mining and geological conditions. The Gorlovka Machine-Building Plant imeni Kirov, in Donetsk Oblast, has begun their series production. [Text] [Moscow EKONOMICHEKAYA GAZETA in Russian No 27, Jul 84 p 3] 11746

CSO: 1822/409

NUCLEAR POWER

NEWS FROM ATOMMASH

Completion of Fourth Building

Moscow SOTSIALISTICHESKAYA INDUSTRIYA in Russian 21 Jun 84 p 2

[Article: "An Important Milestone"]

[Text] The first six months will end within several days and the builders of Atommash must summarize the results of the intermediate finish. An editorial entitled "An Important Position" was published in No 25 (285) of SOTSIALISTICHESKAYA INDUSTRIYA at Atommash. It is reported in the article that the builders are devoting main attention in July to completion of work on the starting complex of the fourth building. Timely turnover of it for operation will permit the enterprise to assimilate additional capacities in manufacture of energy equipment. Considerable work must be completed during this short deadline on housing and cultural and service facilities.

It was noted at a meeting of the oblast staff for construction of Atommash that there is now a sufficient quantity of people and machinery and equipment at the construction site for normal work. There are no complaints against the designers and the technical documentation has been completely issued to the subdivisions. Thus, there is every basis for the program for introduction of starting facilities and complexes to be completed during the first six months.

The date of 24 July is Soviet Youth Day. The first secretary of the Volgondonsk gorkom of Komsomol G. Aleynikov relates in the article entitled "For Important Matters" the affairs and plans of the young men and women of the All-Union shock Komsomol construction project. A report from a meeting of the most active party members of the Volgodonskenergostroy Trust was placed in the issue under the title "The Responsibility of the Supervisor."

The newspaper continues the column "The Atommash Worker Rings Out Proudly," by publishing the story of the leading brigade leader of SMU-9 [Construction and Installation Administration] Ya. Kezhvatov. The articles "Victory of the Concrete Workers" of G. Obukhov and "The Sharp Turn" of V. Magdeyev and responses to critical remarks were also published in the issue.

The reader will find the topical satire of Kuz'ma Volgodonskiy "A Personal Dump Truck" and will become familiar with the news of the culture and everyday life and sports information in the issue.

Second and Third Steam Generators

Moscow SOTSIALISTICHESKAYA INDUSTRIYA in Russian 8 Jun 84 p 2

[Article: "Important Time Gain"]

[Text] SOTSIALISTICHESKAYA INDUSTRIYA at Atommash publishes in No 23 (283) under the column "Behind the Line of Pledges" the article of the chief of the steam generator assembly shop V. Komissarov "The Main Advantage." A year ago the collective began "to fill" the first steam generator and the second and third steam generators are now in the completion stage and the fourth and fifth housings have been delivered for assembly.

The plant workers achieved the main time advantage by using a new block design and more improved assembly technique, which the workers of the SKB [special design office] of Atommash developed successfully. Six steam generators should be manufactured this year at the enterprise according to plan. The high rates of the assemblers inspire confidence that this task will be honorably fulfilled.

How are the critical remarks communists, which they made at meetings of last year's report-election campaign, being implemented? Secretary of the party committee of Zavodstroy I. Vinnichuk talks about this in detail in the article "On the Advice of Communists."

The reporting of Z. Bibikova "Joining," the letter of V. Navozov "The Pocket is Losing Its Reserve" and the article of the chairman of the section mountain tourism of Atommash L. Kobzarev "Only Mountains Are Better Than Mountains" under the column "World of Interests" were published in the issue.

The newspaper places the letter of engineer of the technical archives of Giprogor Institute N. Zaytsev to Kuz'ma Volgodonskiy under the column "The Archives in a Small Family."

The reader will become familiar in the issue with the industrial chronicle of the enterprise and news of culture, everyday life and sports information.

Improvement of Deliveries to Atommash

Moscow SOTSIALISTICHESKAYA INDUSTRIYA in Russian 31 May 84 p 2

[Article: "Deliveries Must Continue Improvement"]

[Text] SOTSIALISTICHESKAYA INDUSTRIYA at Atommash informs us in the article "Improvement of Deliveries Sought" in No 22 (282) of the meeting of the coordinating council. Its participants summarized the fulfillment of socialist pledges on introduction and assimilation of the production capacities of Atommash and of the Rostov AES last year.

The coordinating council noted the timely and high-quality fulfillment of the pledges agreed upon by the collectives of Uralmash, the Izhorsk Plant, the Kramatorsk Plant Energomashspetsstal' and of the Chekhov Energy Machine Building Plant. The winners of the competition of supplier enterprises were repeatedly the Association Kuybyshevenergostroyprom, the Voronezh Busbar [shinnyy] Plant and the Bystrorechensk Quarry Administration.

The collectives of Lengiproenergomash, Leningrad Institute PI-1 and of Atomkotlomash were subjected to serious criticism at the meeting. Untimely delivery and low-quality documentation by them led to an interruption of orders of starting construction projects.

The reports "A Pentagon on an Electrode," "A Test of Reliability," other materials, sports information and news of culture and everyday life were also published in the issue.

Important Construction Reserve Cited

Moscow SOTSIALISTICHESKAYA INDUSTRIYA in Russian 12 Jul 84 p 2

[Article: "An Important Reserve"]

[Text] The article of deputy chief of the department of labor N. Nikitenko "A Guarantee of Success" is published in No 28 (288) of SOTSIALISTICHESKAYA INDUSTRIYA at Atommash under the column "Behind the Line of Pledges." Improvement of the organization of labor and on this basis a reduction of labor expenditures in manufacture of all types of articles, the author emphasizes, is an important reserve, ever more complete utilization of which may provide Atommash with the required increase of labor productivity and will provide the output of additional products.

This year the Atommash workers pledged to reduce labor consumption of equipment to be manufactured by 100,000 norm-hours due to organizational measures, review of maintenance norms and replacement of obsolete and reduced norms by technically substantiated norms. The collective is honorably keeping its word, but much effort must still be continued to achieve the planned level and to fulfill this item of the socialist pledge.

The output of emergency cooling systems for the core has been planned for Atommash since 1980, but this equipment is still being assimilated extremely slowly. How is the production plan for this product being fulfilled this year? The chief of the hydraulic tank shop A. Karachentsev answers this question in his article "An Impossible Task."

Construction of production bases at the Motor Transport Administration is proceeding at low rates. The unsatisfactory status of repair services has a negative effect on the work of transport and strengthening of personnel. For its part, Volgodonskenergostroy Trust is devoting little attention to this problem, assuming that timely introduction of transport facilities into operation is a secondary matter. The reasons for this situation are analyzed in the report of A. Zornin "The Price of a Guarantee."

The article of the secretary of the party bureau of the fourth shell B. Khoshchev "Aiming for the Future" was placed in the issue under the column "A Communist in His Organization." The newspaper publishes the remarks of deputy chairman of the peoples control committee of Volgodonskenergostroy Trust A. Katamanov "Keen Vision or Blindness?" and the article of senior foreman R. Shaymardanov "Reach the Finish." Kuz'ma Volgodonskiy appears with topical satire entitled "On the Earth and in the Heavens."

The newspaper familiarizes readers with news of culture, everyday life and sports information.

Socialist Pledges Fulfilled

Moscow SOTSIALISTICHESKAYA INDUSTRIYA in Russian 29 Jun 84 p 2

[Article: "News From Atommash"]

[Excerpts] SOTSIALISTICHESKAYA INDUSTRIYA at Atommash No 26 (286) opens with reports about the success of the leading collectives of builders and operators, achieved at the finish of the first six months. The integrated brigade of G. Fomenko from SMU-10 of Zavodstroy fulfilled its socialist pledges successfully. The leading collective is more than 1 month ahead of schedule. The scraper operators of the construction administration of mechanized work considerably overfulfilled the tasks on construction of the fifth building.

The newspaper has already printed several articles of the supervisors of collectives participating in construction of Volgodonsk and of facilities of Atommash under the column "Roll-Call of Cost-Accounting Brigades." Brigade leader of Promstroy No 1 N. Tkachenko publishes an article in the issue.

Construction Responsibility

Moscow SOTSIALISTICHESKAYA INDUSTRIYA in Russian 14 Jun 84 p 2

[Article: "An Equal Responsibility"]

[Text] The roll-call of cost-accounting brigades continues in No 24 (284) of SOTSIALISTICHESKAYA INDUSTRIYA at Atommash. The brigade leader of section No 2 of the construction administration Promstroy-1 A. Fadeyev publishes an article in the newspaper "Expand the Range of Responsibility." The author writes that it is difficult to fulfill a contract agreement alone. The organizers of the contract, designers and related workers should be materially interested to an equal degree and responsible for its final result. The principles of this responsibility must be thought out and formulated officially beforehand.

"Our Ally is Creativity" is the title of the article of brigade leader of installers of the Volgodonsk section of Promsvyaz'montazh V. Yeryshev, published under the column "The Worker's Tribunal." The author points out under specific facts how a creative approach to the matter has a positive influence on the final results of labor.

The report of V. Navozov "A Personal Example" is devoted to an important topic--the practice of the socialist competition. The article of V. Lityayev and A. Shtylev "Busy Weekdays" and the letter of the chief of the department of welding materials of the material and technical supply and makeup administration of Atommash L. Udalov "Fines Instead of Wire" were published in the issue.

The reader will find on page 4 materials combined under the column "The Youth Orbit." Affairs, plans and organization of the spare time of young builders and operators of Atommash is discussed in them.

Completion of Annual Plan

Moscow SOTSIALISTICHESKAYA INDUSTRIYA in Russian 5 Jul 84 p 2

[Article: "News From Atommash"]

[Text] What additional reserves can be used to increase the efficiency and quality of work? This question is answered in No 27 (287) of SOTSIALISTICHESKAYA INDUSTRIYA at Atommash in the article "The Key to Acceleration" of brigade leader of finishers of Grazhdanstroy L. Rud'. The author relates in detail about the leading experience of his collective, which decided to complete the annual plan by USSR Constitution Day and to complete the 5-year task by the 115th anniversary of V. I. Lenin's birth.

Commenting on the article of the leading brigade leader, the deputy chief of Grazhdanstroy for economics G. Budyak notes that the guarantee of success of the builders was creation of a stable and experienced collective, introduction of progressive methods of labor and high degree of selflessness of each worker. The experience of the leading brigade of L. Rud' is especially valuable now when all collectives of Grazhdanstroy have adopted increased socialist pledges for this year.

The article by deputy chief of shop No 896 A. Yakimov, who analyzes the course of operations at the start-up unit, was published in the paper under the title "In Bondage to Corrections".

Role of Foremen in Production

Moscow SOTSIALISTICHESKAYA INDUSTRIYA in Russian 24 May 84 p 2

[Excerpts] The article by senior engineer of normative research station No 17 Z. Bulgakova, who talks about the leading experience of the brigade, was published in the issue.

The report of Z. Bibikova was published in the newspaper under the heading "Foremen Yesterday, Today and Tomorrow." The author dwells in detail on the role of foreman in modern production and on his tasks and problems.

Continuing the column "The Worker's Tribunal," the newspaper publishes the article of the welder of housing equipment shop of Atommash M. Marushko under the title "At the Initiative of the Brigade."

The reports of A. Zorin "Because of Ambition" and of G. Aliyev "Kindnesses Recalled," the topical satire of Kuz'ma Volgodonskiy "Miracle Furnace," answers to critical comments, news of culture and sports information are also published in the issue.

Winners of Socialist Competition

Moscow SOTSIALISTICHESKAYA INDUSTRIYA in Russian 11 May 84 p 2

[Article: "Winners Are Selected"]

[Text] The collective of Atommash has been recognized as winner of the socialist competition among the enterprises of the sector for achieving high

indicators in conservation of material, labor and energy resources last year by using inventions and innovative proposals. Issue No 19 (279) of SOTSIALISTICHESKAYA INDUSTRIYA at Atommash reports about this.

How is the collective of the Volgodonskenergostroy Trust fulfilling its pledges for construction of children's rehabilitation institutions? V. Gurov answers this question in his article "Allied Workers, Rise!" "We have opportunities for successful introduction of kindergartens," the author writes. "Only each participant of construction must manifest greater effort and solve all problems in an operational manner."

The newspaper publishes the article of the chief of the NOT [scientific organization of labor] laboratory of Volgodonskenergostroy Trust Ye. Bykova under the column "Improve the Mechanism of Cost Accounting."

The newspaper, continuing the column "Consumer Goods: Demand and Suggestions," publishes the report of Z. Bibikova "A Sullied Kopeck" and publishes the letter to the editor of the chief of the Volgodonsk section of RSU of Gidrospetsfundamentstroy Trust G. Karmazin under the heading "Lack of Coordination Everywhere."

The reader will become familiar in the issue with the article "What Anonymous Did Not Understand," published under the column "Man. Labor. Morals."

6521

CSO: 1822/368

NON NUCLEAR POWER

TURBINE ROTOR CRACK CAUSES POWER STATION FIRE

PM231005 [Editorial Report] Moscow SOTSIALISTICHESKAYA INDUSTRIYA in Russian on 19 October carries on page 1 a 1,000-word dispatch by its own correspondent D. Melikov datelined Mingechaug and entitled "An Alarming Night."

Melikov describes how the discovery of Akif Zeynalov, chief engineer on duty at Mingechaug's Azerbaijan Gres, on a fire in the power station's No 3 unit and the successful firefighting operation, which "lasted 20 minutes."

He concludes his dispatch:

"So what happened with the gres No 3 turbogenerator? A day later, when the machine had cooled down somewhat, Akif Zeynalov personally crawled inside the turbine's rotor section and immediately understood everything. One of the main rotor blades had broken and taken 27 other blades with it. The oil feed pipes were eventually also broken and the oil, hitting under pressure the turbine's surface, which was heated to 400 degrees, caught fire. Further detailed examination of the causes of the accident showed that it resulted from a microfissure in the metal of the disk of the low-pressure rotor.

"In actual fact, this is far from the first incident involving this type of turbogenerator. This is why the story of the people's courage must not mean an end to the matter. The appropriate organizations must study thoroughly the causes of these fissures and hold strictly to account those who have allowed the faulty products."

CSO: 1822/42

PIPELINE CONSTRUCTION

UDC 621.643.002.2+62.001.7

BETTER WAYS OF ERECTING LARGE-DIAMETER PIPELINES DESCRIBED

Moscow STROITEL'STVO TRUBOPROVODOV in Russian No 6, Jun 84 pp 2-5

[Article by O. M. Ivantsov, chief of the Main Engineering Administration of Minneftegazstroy [Ministry of Construction of Petroleum and Gas Industry Enterprises], Doctor of Engineering Sciences and Professor: "Ways for Improving the Technology of Building Large-Diameter Pipelines"]

[Text] Large-diameter (1,020 mm or more) pipelines comprise about 50 percent of the total volume of arterial oil and gas pipeline construction. This is understandable, since large streams of oil and gas can leave West Siberia's fields only along highly productive trunk lines. Since the start of the 11th Five-Year Plan, 22,000 km of large-diameter pipeline have been laid.

The fastest operating pace was achieved during erection of the Urengoy-Pomary-Uzhgorod transcontinental gas pipeline. The most progressive equipment and technology for laying trunk lines and most efficient organization and management of the construction process were applied to this construction job.

An analysis of society's expenditures on developing science and technology in comparison with the economic benefit derived indicated that the greatest benefit is obtained by introducing new technology--it is one-third as great from mechanization, one-fourth as great from automation and the application of computer equipment. True, if the latter is united into integrated automated and mechanized systems and if the integrated use of computer equipment is called for, the benefit quickly rises. However, new technology remains the main component of scientific and technical progress, and it is necessary that computer equipment and automation become components of technology in general. This will raise scientific and technical decisions to the highest level of yield.

Let us examine the various processes of erecting oil and gas arterials from the standpoint of modern demands of scientific and technical progress.

Welding productivity and quality have a determining influence on the pace of pipelaying and on pipeline reliability. A study of the statistical data of many years indicates that defects in joint welding entail manual welding of special butt joints (the welding of sags and curves and the cutting off of

reinforcements and pipe parts) in the overwhelming majority of cases. The conclusion suggests itself that it is desirable, from the standpoint of increasing the pace and quality of the work, to expand in every possible way the use of automatic welding. The problem of automatic nonrotary joint welding, the share of which is substantial in the overall work volume, has now been solved successfully through the use of pressure contact welding and automatic machines with flux-cored electrodes.

During the last 3 years automatic-welding volume on arterial pipelines has increased from 530,000 to 630,000 welds. And each year about 1.2 million joints of trunk pipeline of various diameters have been welded by all methods. During this same time the number of joints made by pressure contact welding and flux-cored electrode welding has increased from 3,500 to 15,600. This is still a small share of the total number. But each day the number of nonrotary joints made with automatic welding increases. The pool of pressure-contact welding complexes is growing continuously. It should be noted that pressure-contact welding complexes--Sever-1, for example--of 1,420-mm diameter pipe provides for, together with high quality, a 3-fold to 4-fold reduction in the labor intensiveness of welding. The hourly and shiftwork pace of operation of Sever-1 test installations that has been achieved on headers and gas pipelines in Urengoy regions indicate that one such machine can weld up to 200 km of 1,420-mm gas pipeline per year. These capabilities, in combination with the Styk welding automaton, will realistically enable the level of automatic welding on arterial pipelines to be brought up to 70 percent in the next few years.

The fabrication of a K-800 type test machine for pressure contact welding of 1,020-1,220 mm pipe has started, and the design of a K-810 type machine with articulated joints that pressure-contact welds curvilinear sections of 1,420-mm pipe also has been developed.

As is known, Styk automatons weld with a flux-cored electrode on the manual backing run, and the problem is to develop the technology and equipment for welding based upon a copper backing run, without reducing productivity. Flux-cored electrode welding raises quality and increases labor productivity 1.5-fold to 2-fold over manual welding.

Automatic welding is performed on about half the joints--the welding of two-pipe and three-pipe lengths at the welding bases. Manual backing run of the weld root was to be eliminated, and this task was solved in new modifications of the BTS 142V and IK-86 type bases.

The indicated automatic-welding technologies contain many mechanized but no automated operations, especially of the auxiliary type. Perhaps a more automated technology is pressure contact welding by Sever-1 complexes, in which the process proceeds according to a flow sheet, on the basis of which the quality of the welded joints is judged. But it is necessary to automate auxiliary operations still more, even with this technology, to transform the equipment into robot-engineering complexes that are controlled by microprocessors, with automatic follow-up on quality of the welding and change in the operating-process parameters.

Thus, the problem is to saturate the construction work with automatic welding equipment and to improve it. However, it is no less important to master new types of automatic welding on a broad scale, to train personnel and to organize the servicing and repair of modern welding equipment.

The share of manual welding in overall trunk-pipeline erection now is large, and even in the future it will be substantial. Therefore, earnest attention should be given to improving manual welding technology.

In recent years breakdown-flowline and group-flowline welding methods that support a high pace of and better quality in the welding of joints have been widely disseminated. There are objective difficulties in doing manual welding, primarily those connected with the weather. It is necessary to continue to improve materials and to equip the welders' workplace in ways that will preclude the influences of weather. The strictest technological discipline, without which no new technology of any kind will yield advantage, is required.

Among the underground structures that are erected for man's various needs, trunk pipelines perhaps are the largest in scale and the most extensive.

The reliability and durability of gas and oil pipeline functioning is determined greatly by the interaction of the pipeline and the soil. About 120 million m³ of soil are worked in a year of pipelinelaying. In 1984 alone ditches totaling 14,000 km in length will be excavated for trunk pipelines.

An enormous amount of work is being done to lay large-diameter pipelines in swampy and flooded ground where the pipe is weighted down with reinforced-concrete weights or is fastened with anchors. In this case the width of the ditches is increased considerably, and they are excavated in the winter, as a rule, when the soil is frozen solid and is high in strength (an impulsive force of 600 on the densimeter). For this reason, the most diverse flow sheets and means are being used to shape ditches. This calls for the combined operation of rotary and single-bucket excavators with bulldozer complexes.

A Glavsibtruboprovodstroy [Main Administration for Pipeline Construction in Siberia] analysis of experiments in working frozen soil showed that preference should be given to the use of rotary excavators for creating parallel ditches of rectangular profile, with a connecting strip between them. The blasthole method must be used to eliminate the strip, and, in so doing, the hole for the explosives should be drilled at least 3.2 meters deep.

Considering the complexity of digging the ditch in permafrost or in seasonally frozen soil, an enormous amount of soil (from 12,000 to 30,000 m³ per kilometer of ditch must be dug, depending upon the method used), the pace of ripping must be raised, and the excavation of a full-size ditch in one pass by a special high-powered excavator has been recognized as the optimal method. Gazstroychina's SKB [Special Design Office] has now designed such a machine, an experimental model of which is being tested on a line. The I-524 excavator can rip up a ditch 3 meters deep and 3 meters wide in permafrost. It has 3 rotors, and its engines have 1,100 kW of power. Its technical productivity is 360 m³/hr. As an intermediate solution, a technology for ripping ditches with ETR 254-01 and ETR 254-04 rotary excavators, which dig to a depth

of 3 meters, should be established. An effective solution involves the use of nonwoven synthetic materials, which will enable the ditch's width to be reduced to 2.1-2.5 meters.

Skilled backfilling of the pipeline with soil is of great importance for protecting the insulation coating. It follows that it is forbidden to throw the soil in chunks onto the insulated pipeline, especially frozen soil. Uniform distribution and compacting of the pulverized soil in recesses of the pipeline, to prevent sliding of the insulated that may be caused by soil settlement, is important.

Rotary ditch backfillers made in recent years cope completely with the back-fill operation. Their productivity is up to 1,200 m³/hr, and they can pulverize even a frozen parapet.

Recultivation of the land is closely associated with the overall program of protecting the environment, and it is performed in vast amounts. Each year 10,000 hectares of arable and other land are subjected to recultivation. The most widely used method of recultivation, which uses bulldozers, leads to great losses of soil fertility, in some cases up to 40-50 percent. Biological recultivation over the entire 45-meter strip of ground allocated is required. At the same time, the pace of the work with a 220-294 kW bulldozer is 0.4 km per day. In accordance with VNIIST [All-Union Scientific-Research Institute for Trunk Pipeline Construction] recommendations, a new technology for recultivating the ground with the ETR 254-05, with supplementary equipment, has been worked out. Loss of fertility of the soil layer has been greatly reduced, the construction strip width has been cut by 30 percent, and 30-60 percent less biological recultivation work is required. A work pace of 2-3 km per day is achieved.

The protection of trunk pipelines from corrosion is being improved continuously. This is attested to by the fact alone that during the 10th Five-Year Plan corrosion-caused failure was 1.7-fold less than during the Ninth. Each year 35-40 million m² of steel pipeline surface coated with insulation, which up until now is being applied mainly in the field, is put into contact with the soil. Large diameter pipelines are insulated, as a rule, with polymer film. All the processes of cleaning and insulating the pipeline on the route have been completely mechanized. Cleaning and insulating machines have been used widely.

In order to raise the quality of insulating work that is done on severe winter days and during rainy weather, NIPiorgneftegazstroy [Scientific-Research and Design Institute of the State Trust for the Industrialized Construction of Oil and Gas Industry Installations] proposed and tested an all-season insulating column, the basic units of which worked under shelters mounted on the moving work units themselves. However, despite the clear usefulness of such an initiative, the simplest equipment still has not been disseminated.

The whole technology alone of cleaning and applying insulated coating at the plant that makes the pipe, and, in some cases, at special bases, can be considered a radical direction in improving the insulation of pipelines. With factory insulation, the pipe is subjected to shotblast cleaning, using

different shot combinations. This creates an active surface, which promotes high adhesion. The mechanized application itself of the insulation in the heating department, together with a careful monitoring of quality of the materials and the technological parameters of the finished product, enables a monolithic coating with a set of highly protective properties to be obtained.

The Volzhskiy Pipe Plant, for the first time in the Soviet Union, has begun to manufacture insulated large-diameter pipe. However, the epoxide coating of these pipes, despite its improved properties and the adoption of special measures for transport, often gets damaged during loading and unloading and during construction.

Polyethylene coating, application of the technology of which has been realized at the Khartsyzsk Pipe Plant, has good protective properties, combined with high impact resistance, and it is marked by good reparability. Although the epoxide coating is more resistant to high temperatures and possesses better adhesion, the polyethylene coating works completely reliably under the temperatures experienced when gas and oil are transported over the large-diameter pipelines.

The factory coating's quality should exceed that of the coating applied on the line in all respects. Only in this way will the final purpose of a radical improvement in protecting pipelines from corrosion--increasing arterial pipeline reliability--be achieved.

Use of the insulated pipe will also open up great opportunities for a further rise in the level of industrialization and pace of the construction.

Gazstroy Mashina's SKB has created a set of 15 vehicles and machines for work with insulated pipeline. Of them, 13 types have successfully passed production tests and have been released for serial production.

The industry has gained much work experience with pipe insulated at the factory. Laying it began in 1976. In past years, 3,850 km of pipeline made of pipe with polyethylene coating and 200 km with epoxide coating have been built. The widest pipe with mill coating was used on the Urengoy-Pomary-Uzhgorod gas pipeline, where sections totaling 2,600 km in length were laid.

Pipeline made of mill-coated pipe can be laid continuously and by various methods. Insulation of the joints should be done at the welding bases. The VNIIST technology, which calls for applying a thermally activated photochemically fastened tape by rotating the pipe sections, with the joint heated beforehand by an internal propane torch, has been validated. Thermally activated radiation fastening of the sealing collar is promising if accelerated methods for installing them are used. The installation of radiation-exposed thermally activated sealing collars on 1,420-mm pipe by two workmen took at least 15-20 minutes.

The technology for building pipelines made of mill-coated pipe still needs improvement, in order to assure the highest effectiveness.

Since the start of development of West Siberia's oil and gas fields and the large-scale laying of trunk pipelines over swampy lands, a new operation has arisen--the ballasting of pipelines over enormous distances in order to keep them in the designed position.

From the point of view of the overall technology for laying large-diameter pipelines, ballasting them has lagged greatly behind the pace of doing other work. And this has hampered construction. Ballasting usually proceeds no faster than 200-250 m/day. And since up to 1.5 million m³ of reinforced concrete weights, more than 100,000 sets of anchors and about 70,000 tons of cast-iron weights for underwater crossings are installed per year, ballasting has affected construction deadlines.

The technology for installing weights is related to their design. Preference has now been given to UBO-type weights. Installing them is more complicated and labor intensive.

Of the newly developed designs that were tested in 1981-1983 and recommended by the interagency commission for production, the wedge-shaped UBK-type weights for swamps with peat deposits up to 2.5 meters deep are of practical interest. They are technologically feasible for manufacture and without labor, just like saddle-shaped weights, and can be installed in groups with one sweep increment of the crane.

Ring-shaped UKSh-type poured-slag weights have been tested successfully at underwater crossings. They were made by pouring liquid slag into split metal molds with cool under a special procedure. Their density is more than 3 tons/m³. The beltlike poured-slag UShO-type weights have even greater density (3.3-3.5 tons/m³).

Considering that 70 percent of the pipeline segments that have been laid through swampy land are held down with reinforced-concrete weights, with the consumption of about 2,000 tons of reinforced concrete per kilometer, replacing them with weights made of metallurgical slag will, according to the consultants' evaluations, enable labor expenditure to be cut in half, the requirement for cement to be reduced by 75 percent, the freight hauling involved to be reduced 40 percent, and an economic benefit of up to 3 million rubles to be obtained for each 100 km of pipeline. Change in the design of the weights and selection of the optimal one and the use of metallurgical slag will reduce labor intensiveness in ballasting and will enable the work pace to be increased. The mission of bringing the ballasting pace of large-diameter pipelines by each flowline group up to 1 km/day has been established.

A rise in the reliability of keep the pipe in the designed position entails the need to increase the number of weights and anchors and also to use the soil's ballasting characteristics, combined with the use of unwoven synthetic materials. VNIIST, in collaboration with MINKh i GP [Moscow Institute for the Oil and Gas Industry imeni akademik I. M. Gubkin] and Glavtruboprovodstroy [Main Administration for Pipeline Construction], has developed and tested cantilever-type pile anchors that will provide a restraining force of up to 300-400 kN. Their use will enable the labor intensiveness of ballasting to be reduced.

Research institutes, KB's [design offices] and Orgtekhstroy [State Trust for the Industrialization of Construction] should choose optimal solutions for pipeline ballasting and should create technologies whose implementation will insure a unified rhythm for laying pipelines.

For many years now pipelines have been laid by the continuous lowering method, this method being combined (except in the case of insulated pipe) with cleaning and insulation. In principle, the laying pace is thus determined by the productivity of the indicated operations. As is known, high results are reached in laying pipelines. The complexity of carrying out this operation, which is important from the standpoint of protecting the pipelines, lies in the fact that under field conditions it is practically impossible to measure and monitor the effects of the forces on the pipelines. The SPKB [Special Design Development Office] of Proyektneftegazspetsmontazh [Institute for Designing Specially Installed Equipment for the Oil and Gas Industry] is working on automated control of this process.

MINKh i GP developed several years ago, jointly with Gazstroy Mashina's SKB, a basically new method for laying pipelines--the "nonlifting method." However, this method, despite its advantages, has not found application. A variety of "nonlifting" schemes for laying pipelines is of interest. They call for the passage of two or three earth-moving complexes, including lateral-excavation rotors, along the axis of the pipeline that is being assembled and laid. Such continuous-excavation earthmoving machines move along the pipeline by a magnetic propulsion system or by a stepping installation, insuring the integrity of the insulating coating. The pipeline is lowered smoothly under its own weight into the excavated ditch, lying tightly on its bottom and without damage to the insulation, since the ditch's configuration is copied from the pipeline. Some of the machines provide for gradual deepening. Under this technology, the pipeline can be laid strictly at the designed grade, regardless of the terrain, the necessity for a set of pipelayers is dispensed with, and a very high pace of laying is provided for. A model of an earthmoving machine for lateral excavation has now been created.

During pipeline construction, the erection of numerous underwater crossings of rivers, especially large ones, and reservoirs presents great complexity.

VNIIST and Soyuzpodvodtruboprovodstroy [All-Union Construction Association for Laying Pipelines Under Water] have developed a new method for building pipelines with the simultaneous use of long-dimension pipeline and weights (with roller supports) which are made at the base and assembled during the pipe-laying process, and enable underwater pipelines up to 1,420 mm in diameter to be erected over large rivers, and, in the long term, across reservoirs with a water surface of up to 5 km, the reliability of the crossing and the safety of laying the line to be increased, the labor intensiveness of the operations to be reduced, the cost of the construction and installing work to be cut, and construction time to be shortened.

Along with the traditional method, the technology of erecting underwater crossings by means of special pipelaying barges has been disseminated. At present, new specialized pipelaying and pipeburying ships and other equipment exist or are being created, to support the erection of underwater crossings of rivers with complicated geological and hydrogeological conditions.

Technical progress in building underwater crossings on small rivers can be made by establishing crossings equal in diameter to the main arterial, including 1,420-mm pipe, by introducing a basically new technology and the mechanized equipment for implementing it. One of the promising technologies is ditchfree pipelinelaying by drilling directly under the bottom of the water body, at depths beyond possible deformation of the riverbed and the floodplain. The new technology, in combination with the constructional use of a pipe-in-a-pipe crossing, excludes every influence on the environment, both during construction and during the period of operating the crossing. By using the new technology, earthmoving work is reduced 10-fold, pipeline ballasting and shore-reinforcement work are no longer necessary, construction time is reduced, and the number of pieces of equipment and servicing-personnel employed is lessened.

Experimental work is being done jointly by the industry's Scientific-Research Laboratory for Pipeline Erection under MINKh i GP imeni I. M. Gubkin, the Institute of Mining Affairs imeni A. A. Skochinskiy, the Serpukhov Integrated Design-Development Section of the Gazstroy Mashina SKB, Glavtruboprovodstroy and the Soyuzpodvodtruboprovodstroy Association. The Gazstroy Mashina SKB, VNIIST and the VNII [All-Union Scientific-Research Institute] for Drilling Equipment are working, together with Uralmash, on creating a complex for drilling crossing holes up to 1,420 mm in diameter.

Tests prior to turnover for operation occupies an especially important place in the system of reliability and integral assessment of the quality of a trunk pipeline that has been built. At present, a general trend toward an increase in the volume of hydraulic tests, which will enable a test pressure up to the yield stress, permitting a large number of defects to be found, and, consequently, increasing the reliability of erection, is discernible. Hydraulic testing, moreover, is safer and cheaper than pneumatic tests with air or gas. A great length of the Urengoy-Pomary-Uzhgorod gas pipeline was tested by the hydraulic method with great success.

Experience indicates that the period for completing construction is extended by 15 percent because of the time spent in cleaning the cavity and in conducting tests. Therefore, hydraulic testing should be performed during the course of the whole complex of pipeline-erection operations. The construction of a large number of gas pipelines in the north and the need to turn them over for operation in the wintertime makes pneumatic tests with natural gas inevitable.

In northern, very swampy regions of West Siberia, large-diameter pipelines are laid mainly during the winter. The elimination of seasonality--the creation of a technology for building in the summer--is one of the general directions for increasing pipeline construction effectiveness.

Energetic searches for new technological solutions are being made in the industry's scientific-research and design-development organizations along three main directions: the creation of transport and operating equipment with high off-the-road capability that is adapted to laying pipelines in swamps of various types during the summer under the usual scheme; the construction of temporary roads that will allow ordinary mechanized columns to operate; and the

creation of a single transport technology of high off-the-road performance equipment that will execute the whole set of operations.

In our view, better universal solutions for laying large-diameter pipelines in highly swampy areas are possible with the creation of a technology for erecting them with the use of the prototype for laying offshore pipelines from pipelaying bases. It is desirable to develop and test a large all-terrain platform based on the air-cushion principle or with aerial emptying, which calls for the placement thereon of a resistance-welding machine, devices for insulating joints, and a plowlike earthmoving mechanism. This can be the key solution to the problem. A program for creating such a complex has been worked out.

Although preliminary preparation of the route and the engineering and operational preparation thereof, which call for the erection of crossings across natural and man-made obstacles and segments of unusual complexity and labor intensiveness, are becoming the norm for trunk pipeline work, the technology of doing the work and supplying the machinery for it require further improvement.

The realization of machine technology with elements of automation is a concept of modern technology. The technical operating flowline group, which now embodies the organizational principle in the construction of large-diameter pipelines, has high-powered equipment with integrated mechanization of various processes. Total power of the machinery in the flowline group averages 14,000 kW, the power-worker ratio 54 kW per person. This enables still higher tasks to be assigned to pipeline construction. The realization of new technologies will provide for a substantial increase in the effectiveness of trunk pipeline erection, which, in turn, will promote successful fulfillment of the energy program.

COPYRIGHT: Izdatel'stvo "Nedra" "Stroitel'stvo truboprovodov", 1984

11409

CSO: 1822/348

PIPELINE CONSTRUCTION

UDC 621.643:621.791

AUTOMATIC PIPELINE WELDING, MANUAL WELDING METHODS COMPARED

Moscow STROITEL'STVO TRUBOPROVODOV in Russian No 6, Jun 84 pp 16-17

[Article by M. Z. Sheynkin of VNIIST [All-Union Scientific-Research Institute for Trunk Pipeline Construction]: "A Rise in the Efficiency of Trunk Pipeline Erection, Based upon the Automation of Arc Welding"]

[Text] Automatic welding of nonrotary joints with flux-cored electrodes by the Styk complex has been used increasingly in recent years to erect 1,220- and 1,420-mm diameter trunk pipelines [1 and 2].

The main distinction of the technological process of welding nonrotary pipe seams that has been developed in the USSR is the realization for the first time in world practice of positive shaping of the molten bath, which is made by use of the flux-cored electrode and artificially cooled shaping shoes [3 and 4]. The slag that is formed during melting of the flux-cored electrode at the prescribed melting temperature and interval of the crystallization range serves as operating lubrication between the heated surface of the molten bath and the shoe. It protects the shaping device from being tack-welded to the joint. Positive shaping provides for the retention of a molten bath of considerably larger volume and weight during dressing of the edges in various spatial positions than during free shaping.

The volume of the molten bath is increased through the welding current, which, for a given joint perimeter, lateral cross-section of the beveling, and deposition rate factor, determine the machine time for welding the seam (table 1).

Table 1 cites the machine time for welding for three arc-welding methods currently used for the erection of continuous strands: manual arc welding, automatic welding in a shielded-gas medium, and automatic flux-cored electrode welding. Each of these methods provides for a different number of joints welded per unit of time and different quality thereof. The effectiveness of these methods as a category of the cost of achieving a result (in labor intensiveness, cost of the welded joint, and so on) is not identical.

The machine time for welding a joint with one arc that is shown in table 1 does not determine completely the benefit of the various welding methods. Aside from the continuity of auxiliary, preparatory and concluding operations, the benefit is greatly affected by the number of welding sets that simultaneously go into operation during erection of a given segment of the pipeline,

Table 1

Machine Time for Welding a Joint 1,420 mm in Diameter with One Arc

Welding method and electrode (wire) diameter	Dressing area, cm ²	Deposition rate factor, g/A·hr	Current, A.	Welding time, hr
Manual arc, 4 mm electrode....	2.0	9.0	170	4.6
Automatic, in shielding gases, 1 mm wire.....	1.4	11.2	200	2.2
Automatic with a flux-cored electrode, 2.3 mm.....	2.0	13.5	350	1.5

as well as the time spent assembling and welding the root layer of the joint (prior to movement of the alignment guide to the next joint), lowering the assembled pipeline onto the support, and freeing the pipelayer.

From these standpoints, manual arc welding and automated welding in a shielding gas medium have advantages, since, because of their greater layering capability, they permit a larger number of welding sets to be put into operation. Nor do they cede anything to automatic welding with flux-core electrodes with positive shaping, even in speed of welding the root layer, allowing a shorter time to be spent on assembly and welding prior to release of the inner alignment guide. The latter also dictates that automatic welding with positive joint shaping now be used in combination with manual arc welding of the root layer.

As for the effectiveness of the welding methods used, as a category that determines the cost of a seam, this depends directly upon the machine time for welding. The data shown in table 1 testify that the machine time for welding with one welding head of a Styk complex is less, by a factor of more than three, than for manual arc welding. It is natural that any mechanized welding method requires much time for preparatory and concluding operations (basically, placing the apparatus at the seam and removing it therefrom, preventive maintenance, and setting up). Therefore, in practice, the use of one Styk complex installation with two welding heads will enable four welders to be replaced and, as a result, the productivity of the concluding welding operations to be doubled [2].

More detailed actual indicators of the economic effectiveness were counted up on the basis of the results of the operation in January-September 1983 of eight Styk complexes which belonged to various operating organizations. For comparison, the operating indicators of three Styk complexes that were being used successfully by Ukrqiprovodstroy [Ukrainian Pipeline Construction Trust] were cited [1 and 2].

Economic effectiveness was determined in comparison with manual arc welding of nonrotary seams. For this purpose, actual operating indicators were used for that same period of 1983 for 14 flowline operations groups that welded 1,420-mm diameter pipe, and 9 that welded 1,220-mm pipe. The results of the study are shown in table 2.

It was established that during the first 9 months of 1983 a total actual economic benefit of more than 208,000 rubles was obtained from operating the 8 Styk complexes. In so doing, labor expenditures were reduced by 26 percent for welding a 1,420-mm diameter seam, by 43 percent for welding a 1,220-mm diameter seam. The prime costs for welding operations on 1,420-mm pipe were reduced by 8 percent, on 1,220-mm pipe by 49 percent. Ukrtruboprovodstroy got an economic benefit of 174,000 rubles from operating the three Styk complexes. Labor expenditures were reduced 48 percent for welding 1,420-mm pipe, by 60 percent for 1,220-mm pipe. The prime cost was reduced by 33 percent for welding 1,420-mm pipe, by 70 percent for 1,220-mm pipe.

Thus, the economic indicators for welding 1,220-mm pipe are higher than for 1,420-mm pipe. This is explained by the comparatively small shift productivity in welding 1,420-mm diameter pipe, which increases considerably the share of the cost of the vehicles and machinery in the prime cost of making a seam. These expenditures often are still higher because of the reserving of equipment (one reserve welding installation for two operating ones).

Smaller shift productivity is explained also by the need to weld manually, in addition to the root layers on the 1,420-mm pipe of 15.7-mm wall thickness, a third filling layer, since, with this wall thickness, after the root layers are welded, a melting space remains in which, during automatic welding with a 2.4-mm diameter fluxed-core electrode, it was not possible to form two layers. The increase in the number of layers welded at the seam by manual welding requires an increase in the number of welders [2].

The considerable differences in work indicators for Styk complexes indicates that large reserves exist for increasing the efficiency of their use. Rough calculations indicate that, for budget purposes, the critical* estimated productivity (for an 8-hour shift) of flowline groups that use two-unit Styk complexes is 7.4 seams for 1,420-mm pipe, 9.4 seams for 1,220-mm pipe. This corresponds to an equipment-shift productivity of 13 and 16 seams. Economic effectiveness is achieved with an increase in productivity above the critical productivity.

In order to increase the technical and economic indicators of the work of flowline groups that use the Styk complexes, a number of organizational and technical measures must be taken. The work of flowline groups that use automatic Styk-complex welding should be planned with precision. Elementary estimates indicate that, with 1½-shift operation, these flowline groups should weld at least 8-9 km of 1,420-mm pipe per month and at least 10-11 km of 1,220-mm pipe. In order to avoid idle Styk complex time, they must be provided with a work front on time.

Cutting the time for startup and setting-up work at the start of the operation will help to increase effectiveness. This work is now being reduced in the three subunits that have gained enough experience and have formed cadres of setting-up workers, the centralized training of whom still has not been organized. The quality of operator training must be improved by increasing the number of practical exercises in welding pipe seams.

*For critical productivity, we take that productivity at which the prime cost of the work is equal to the prime cost of manual arc welding.

Special attention should be paid to improving the system for providing the complexes with parts that wear rapidly (nozzles, tips and shoes) and with spare parts (thyristors, printed circuit boards, seals for hydraulic systems, and so on). It is necessary also to strengthen the repair service, particularly to master the output of mobile repair shops that have been designed for servicing Styk and Sever complexes. A number of engineering measures, primarily conversion to welding with PP-AN 24 (PP-AN 24S) flux-cored electrodes instead of PP-AN 19's, must be taken and serial production of the electrodes organized. The use of electrodes of the given grade will enable the deposition rate factor to be increased, the force of the current to be raised to 400A, and machine time for the welding to be reduced about 1.5-fold in comparison with welding with the PP-AN 19 on a current of 350 A.

It has been established that, when welding 1,420-mm diameter pipe with 15.7-mm wall thickness, it is possible to dispense with manual arc welding of the filler layer and to convert to two-layer automatic welding with a 2-mm flux-cored electrode. This will enable efficiency in welding such pipe to be raised.

Assembling joints with gaps down to the minimum tolerance for later automatic welding with flux-cored electrodes, and an additional backing run for the lower fourth of the joint perimeter in order to avoid stopping for random burns, should be recognized as effective operating measures [2]. It is also necessary to issue more standardizing engineering papers on the new welding method and to provide them with additional detail.

BIBLIOGRAPHY

1. Kopyshvskiy, V. V. "Use of the 'Styk' Welding Complex." STROITEL'STVO TRUBOPROVODOV [Pipeline Construction], No 1, 1983, pp 22-23.
2. Lerman, M. G. "The Introduction of Automatic Welding by the 'Styk' Complex." STROITEL'STVO TRUBOPROVODOV, No 9, 1983, pp 13-14.
3. "Automatic Welding of Nonrotary Seams of Large-Diameter Pipe with Self-Protecting Wire," by B. Ye. Paton, I. K. Pokhodnya, V. Ya. Dubovetskiy, et al. STROITEL'STVO TRUBOPROVODOV, No 2, 1981, pp 22-24.
4. "Resource-Saving Technology for Pipeline Welding." I. K. Pokhodnya, V. Ya. Dubovetskiy, V. N. Shlepakov, et al. STROITEL'STVO TRUBOPROVODOV, No 6, 1982, pp 15-17.

COPYRIGHT: Izdatel'stvo "Nedra" "Stroitel'stvo truboprovodov", 1984

11409

CSO: 1822/348

WAY TO FIND STRENGTH OF ON-SITE PLASTIC PIPELINES DEvised

Moscow STROITEL'STVO TRUBOPROVODOV in Russian No 6, Jun 84 pp 45-47

[Article by Yu. D. Ovsyannikov and N. G. Novichenko of the Kiev Branch of VNIImontazhspetsstroy [All-Union Scientific-Research for Installing and Special Construction Work]: "The Strength and Stability of Pipelines Made of Plastic"]

[Text] Because of the substantial increase in the production of polymer pipe and the expansion of the area of their application, it has become necessary to develop a unified methodology for analyzing pipelines made of polymer materials for strength and stability. The existing standards are limited either to general instructions on static analysis or to making recommendations on the choice of the type of pipe as a function of the parameters of the product being transported. However, these instructions and recommendations are partially outdated, since they were made without taking into account the changes in rise of the quality of the pipe produced in recent years.

A generally accepted method for analyzing designs in accordance with the limiting states has been set as a basis for a proposed methodology for analyzing surface industrial pipelines for strength and stability.

The first limiting state (load-carrying capacity) corresponds to the condition:

$$N = nN^H < f(m, K, R^H, S), \quad (1)$$

where N is the force from the computed loads; N^H is the force from standard loadings; n is the coefficient of overload; f is a function that corresponds to the nature of the force (tension, compression, bending, and so on); m is the coefficient of the operating conditions; K is the coefficient of the material's homogeneity; R^H is the standard resistance of the material; and S is the geometric nature of the cross-section.

The second limiting state (deformation) corresponds to the condition

$$[\epsilon] > \epsilon(E, S), \quad (2)$$

where $[\epsilon]$ is the maximum permissible value of deformation; and $\epsilon(E, S)$ is the deformation that is a function of the material's module of elasticity and its geometric characteristics.

The strength and deformational characteristics of polymer materials, unlike traditionally used materials (steel, glass, nonferrous metals, and so on), are essentially functions of temperature and they change over a period of time, because of which the standard strength and deformation characteristics contained in the right side of conditions (1) and (2) should be designated as functions of the pipeline's period of service and its operating temperature. It is proposed that the permissible computed stability of the material of plastic pipe be determined by the expression

$$R = R^T K_{AC} K_{AC}^T K_Y K_C \quad (3)$$

where K_{AC} is the coefficient of reserve strength that considers the effect of the duration of the action of the loads on the long-term resistance of the material; K_{AC}^T is the coefficient of reserve strength that considers the effect of temperature; K_Y is the coefficient of the pipe's operating conditions that considers the area of its use; and K_C is the coefficient of strength of the pipe's joints.

With ordinary methods for analyzing designs for strength, including pipelines made of steel, R^H is either determined according to the standards (or handbook) literature or it is established on the basis of standard short-term tests. For polymer materials, because of their inclination toward static fatigue, this approach to determining R^H is unacceptable, since it does not provide adequate information about the properties of materials over the course of time. This can be got only on the basis of data of long-term tests.

The value of R^H should be established on the basis of indicators that describe the long-term strength of extruded pipe grades made of polymers. These indicators are the monitored stresses in the pipe wall during tests for internal hydrostatic pressure for 1 hour at 20 degrees C, which the pipe should withstand in accordance with existing standards and specifications. The use of these data in formula (3) should insure conformity of the pipeline's computed characteristics to the strength indicators of pipe that is produced by domestic industry.

The values of the K_{AC} and K_{AC}^T coefficients are determined by the curves of the rupture strength of the pipe, which are constructed in accordance with the results of 20-year tests, while for lengthier periods of pipe operation they are computed on the basis of existing test data.

The chemical stability of polymer materials, including pipe materials, is determined in accordance with the standards and handbook data as a function of the concentration and the temperatures of the substances with which it comes in contact. According to the accepted classification, they are subdivided into: resistant--S, relatively resistant--OS and nonresistant--N. The difference in chemical resistance of the pipe's polymer materials of the pipe and the aggressive and toxic substances it transports is considered by the coefficient K_Y .

The values for the coefficient K_C that enter into formula (3) are shown in the table.

Coefficient of Strength of Joints for Various Pipe Materials

Method of joining	Pipe materials		
	PND and PVD*	PP**	PVKh***
Resistance welding, end-to-end:			
For joining pipe and connecting parts....	0.9-1.0	0.9-1.0	-
For making T-joints:			
Uniform-passage oblique-angle and non-uniform-passage right angle.....	0.3-0.4	0.3-0.4	
Uniform-passage right-angle and segment taps.....	0.6-0.7	0.6-0.7	-
Resistance welding into a bell mouth for joining pipes and connecting parts.....	0.95-1.0	0.95-1.0	-
Gluing in a bell mouth for joining pipes and connecting parts.....	-	-	0.9-1.0
Extrusion welding (with V-shaped dressing of the bead):			
For joining pipes.....	0.6	0.55	-
For making T-joints and segment taps...	0.3-0.4	0.3-0.4	-
Gas stick welding (with V-shaped bead):			
For joining pipes.....	0.35	0.35	0.4
For making T-joints and segment taps...	0.15-0.2	0.15-0.2	0.2-0.25
On slip-on flanges that are installed:			
On pipes welded (or glued) to pipes to spigots near the flange.....	0.9-1.0	0.9-1.0	0.9-1.0
On pipes with molded reinforced clamps...	0.8-0.9	0.8-0.9	-
On pipes with flanged edge.....	0.5-0.7	0.5-0.7	0.5-0.7

*Low-pressure polyethylene and high-pressure polyethylene.

**Polypropylene.

***Polyvinyl chloride.

Calculations made in accordance with formula (3) showed that the computed resistances practically coincide with the maxima of the stress-rupture strength cited in the literature. A comparison of R^H with handbook data on mechanical properties indicates that their values do not exceed $0.25 \sigma_T$ (σ_T is the material's yield limit) at the appropriate temperature). Based upon the information in the literature on the limits of the linear viscoelastic behavior of plastics, it follows that the pipeline material, throughout the whole working range of the loads acting upon it, will work in the area of linear viscoelasticity, and, therefore, analyses of pipeline strength and deformability can be performed based upon the relationships of the theory of linear viscoelasticity.

An analysis of works published in recent years that were dedicated to studying the strength of various plastics under complicated stress states showed that onset of a dangerous state in structure made of plastic can, in the case of brittle destruction thereof, be described by the first theory of strength, and, in the case of viscous destruction, by the fourth theory of strength.

Considering the differences in the nature of destruction, strength analyses of pipelines made of plastic should be made in accordance with the method of the limiting state, according to the condition

$$\sigma_{\text{KB}} < R, \quad (4)$$

where σ_{KB} is the equivalent stress, which is calculated to take into account the forces that act on the pipeline as a function of the hypothetical nature of the destruction:

where there is brittle destruction according to the first theory of strength

$$\sigma_{\text{KB}} < \sigma_{\text{max}}, \quad (5)$$

where there is viscous destruction according to the fourth theory of strength

$$\sigma_{\text{KB}} = \sqrt{\frac{1}{2} (\sigma_{\phi} - \sigma_z)^2 + (\sigma_z - \sigma_r)^2 + (\sigma_r - \sigma_{\phi})^2}, \quad (6)$$

where σ_z , σ_{ϕ} and σ_r are, respectively, the normal stresses in the ring, axial and radial directions.

An analysis based upon deformability usually comes down to determining the permissible values of a span between fixtures (supports and suspensions) of the pipeline during horizontal and vertical laying. The technical-standards literature contain numerous recommendations on values for spans which are, as a rule, in the form of tables without reference to the original analytical formula. When comparing these data with each other, for identical laying conditions, diameters and temperatures, a considerable difference was observed in the recommended values of the spans, for both horizontal and vertical laying. For example, for a temperature gradient of 20 degrees C, they are 5 to 40 percent, and, for 40 degrees C, from 50 to 100 percent. The discrepancies noted are connected in all probability with differences in the original formulas (or premises) used for the computations, and they testify to the lack of a unified methodology for computing the distance between the fixture for the pipelines. M. G. Sukharev's work, "Polietilenovyye trubyy v stroitel'stvo" [Polyethylene Pipe in Construction] (Leningrad, Stroyizdat, 1967) explains more completely the problem of analyzing plastic pipelines for rigidity and stability for various types of laying.

In accordance with the recommendations of this work, the values for the spans between pipeline supports is determined for vertical laying in accordance with the formula:

$$l_0 = \frac{m_1}{\sqrt{\alpha \Delta t}} D, \quad (7)$$

and, for horizontal laying, based upon the condition of the permissible sag $[f] \pm l_0 (500-1,000)$, in accordance with the expression

$$l_0 = \frac{m_2 \beta}{\sqrt{\alpha \Delta t}} D. \quad (8)$$

Here D is the outer diameter of the pipe; α is the material's thermal linear-expansion coefficient; Δt is the calculated temperature gradient, which is

assumed to be equal to the difference between the maximal (or minimal) possible temperature of the pipeline wall during operation and the highest (or lowest) ambient temperature at which the assembly of locking pipeline joints is carried out; m_1 and m_2 are the coefficients that characterize the pipeline's geometric parameters--for pipe made from PND, PP and PVKh $m_1 = 1.0-1.1$ and $m_2 = 1.3-1.4$, while for PVD pipe $m_1 = 0.95-1.05$ and $m_2 = 1.2-1.3$, the lesser coefficients being, in this case, for lightweight pipe and the larger ones for heavier types; β is the coefficient that is determined from the chart shown in the figure. In order to determine β it is necessary first to compute the auxiliary values

$$At = Bt \frac{\delta}{D^2}, \quad (9)$$

$$Bt = \frac{1}{500+1000} \left(\frac{23}{\gamma_{TP} \lambda} \right) E \alpha \Delta t \sqrt{\alpha \Delta t}, \quad (10)$$

$$\lambda = 1 - \left(\frac{d}{D} \right)^2 \left(1 - \frac{\gamma_{TB}}{\gamma_{TP}} \right), \quad (11)$$

where δ is the pipe's wall thickness; d is the pipe's internal diameter; γ_{TB} and γ_{TP} are, respectively, the density of the substance being transported and of the pipe material; and E is the modulus of elasticity of the pipe material, which depends considerably upon the temperature and the time of the effect of the load.

The Coefficient β as a Function of the Parameter At :

- a. $At = 0-0.05$.
- б. $At = 0.05-0.5$.
- в. $At = 0.5-3$.

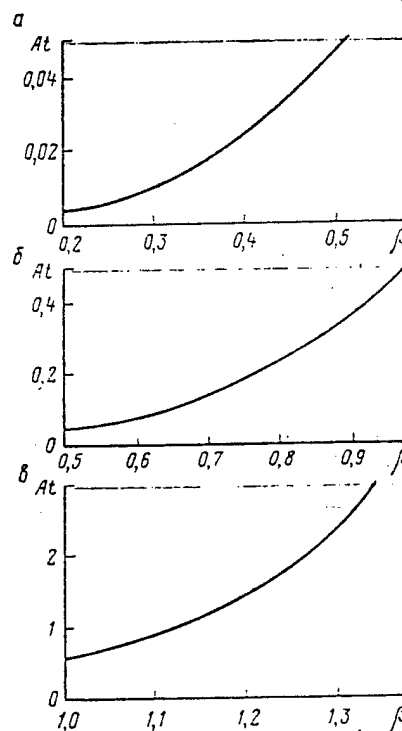

There are no data in the scientific and technical literature about the modulus of elasticity for plastic for the long-term effects of loads that are equal to the actual period of operation of the pipelines. The existing information is based upon various types of extrapolations and can be generalized by the empirical relationship

$$E = K_E E_0 \quad (12)$$

where E_0 is the short-term (initial) modulus of elasticity of the pipe material, which is determined on the basis of standard tests of samples under single-axis tension and at the appropriate temperature; K_E is the coefficient that considers the effect of the duration of operation on the plastics' deformational properties. For periods of operation up to 5 years $K_E = 0.45-0.50$, from 5 to 10 years $K_E = 0.40-0.45$, and for more than 10 years $K_E = 0.35-0.40$.

The proposed methodology has been approved by several design organizations, including the LNPO [Leningrad Science and Production Association] Pigment, whose designs for the construction of on-site pipelines used various polymer pipes in amounts of up to 500 tons.

It is desirable that the methodology set forth be recommended for inclusion as standard information in the "Directive on the Design of Industrial Pipelines Made of Plastic Pipe," which is being developed by a number of organizations under the direction of USSR Gosstroy.

COPYRIGHT: Izdatel'stvo "Nedra" "Stroitel'stvo truboprovodov", 1984

11409

CSO: 1822/348

PIPELINE CONSTRUCTION

WORK OF PETROLEUM SCIENTIFIC-TECHNICAL SOCIETIES REVIEWED

Moscow STROITEL'STVO TRUBOPROVODOV in Russian No 6, Jun 84 p 42

[Article: "Raise the Role of the NTO in Accelerating Scientific and Technical Progress"]

[Text] The 4th Plenum of the Central Administration of the NTO [Scientific and Technical Society of Oil and Gas Industry Workers imeni Academician I. M. Gubkin], at which questions of increasing the role of NTO organizations, scientific-research institutes, and vuzes for oil and gas science in accelerating scientific and technical progress in the oil and gas industries and in the construction of these industries were examined, was held in Moscow.

Representatives of top-level Minnefteprom [Ministry of Petroleum Industry], Mingazprom [Ministry of Gas Industry] and Minneftegazstroy [Ministry of Construction of Petroleum and Gas Industry Enterprises] organizations took part in the plenum's work. Major reports that revealed the basic directions of the activity of the industry's science were rendered by VNIIGaz [All-Union Scientific-Research Institute for Natural Gas] Director A. I. Gritsenko, IGIrGI [Institute for the Geology and Development of Fuel Minerals] Director N. A. Nekrasov, VNIIST [All-Union Scientific-Research Institute for Trunk Pipeline Construction] Director A. M. Zinevich, VNII [All-Union Oil and Gas Scientific-Research Institute] Director G. G. Vakhitov and MINKh i GP [Moscow Institute for the Petrochemical and Gas Industries imeni akademik I. M. Gubkin] Vice Rector for Scientific Work A. N. Dmitriyevskiy.

The reports noted that the efforts of the scientific and technical community were aimed primarily at increasing the contribution to more complete use of the country's scientific and technical potential and at implementing the USSR's Energy Program. The scientists focused their attention on questions of speeding up introduction of the achievements of science, technology and advanced experience into production, raising the technical level of development work, reducing the materials and labor intensiveness of manufacturing output, improving capacity utilization, and mechanizing and automating production processes.

Many NTO organizations of the oil and gas industry, VOIR [All-Union Society of Inventors and Innovators] and many other creative associations which systematically conduct inspections, competitions, conferences and seminars are

taking an active part in speeding up scientific and technical progress. The number of NTO councils that are performing the functions of technical-and-economic and industrial-production councils of associations, enterprises and organizations has risen. Purposeful work on increasing creative activity is being carried out by primary organizations of the industry's NTO's of Moscow, Tyumen, the Ukraine and a number of other administrations.

The plenum noted that the collectives of Minneftegazstroy organizations and enterprises completed ahead of time the construction program for the first 3 years of the five-year plan. Labor productivity in the industry rose by 21 percent, exceeding the level called for by the end of the five-year plan. The amount of contracting work performed grew substantially, and plan and other basic technical and economic indicators were implemented successfully.

An extraordinarily important goal was advanced in fulfillment of the established tasks of the current five-year plan. Today, more than at any time, the degree of organization and order, strict discipline, the ability to take notice in time of that which is new, bringing started matters to their conclusions, a decisive struggle with bureaucratism, and unconditional assurance of the execution of party and government directives are important.

These requirements make it necessary to further increase the intensity of the work of all NTO subunits and collectives of scientific-research institutes and vuzes in the oil and gas field.

The work on creating means for mechanizing and automating construction and installing work must be intensified. Work of secondary importance which does not exert an important influence on the technical level of production is still being encountered on the projects lists of scientific-research institutes. The share of basic and fundamental research, which provides for the creation of a scientific backlog, and also of special-purpose work on problems of saving fuel, power and raw-material resources, is small. Vuzes that possess substantial scientific potential still are not adequately taking part in solution of the most important fundamental and applied problems of the oil and gas industries. Scientific problems frequently are resolved in unintegrated fashion, and problems of interindustrial and regional natures are not being assigned and solved.

The plenum approved the activity of the primary NTO organizations of VNII, VNIIGaz, VNIIST, IGIIRGI and MINKh i GP on increasing creative initiative that is aimed at further promoting scientific and technical progress in light of the decisions of the 26th CPSU Congress and the November 1982 and subsequent CPSU Central Committee plenums. It is recommended that primary NTO organizations study this experience and later use it widely. The integration of science and production should be deepened and introduction of the achievements of science, technology and advanced experience into practice, using modern forms and methods for organizing and conducting scientific research and experimental design development, should be expanded and accelerated.

The plenum charged the Presidium of the Central Administration of the NTO of the Oil and Gas Industry imeni akademik I. M. Gubkin with developing and

implementing measures for insuring the active participation of the society's primary organizations, the scientific and technical community, and inventors and rationalizers in solving the tasks set by the party and the government, and with assisting in establishment of the necessary conditions for fulfilling these tasks.

COPYRIGHT: Izdatel'stvo "Nedra" "Stroitel'stvo truboprovodov", 1984

11409

CSO: 1822/348

PIPELINE CONSTRUCTION

UDC 621.643.002.2

PRECAUTIONS IN LAYING MULTIPLE-LAYER PIPE RECOMMENDED

Moscow STROITEL'STVO TRUBOPROVODOV in Russian No 6, Jun 84 pp 19-21

[Article by Ye. A. Anikin of VNIIST [All-Union Scientific-Research Institute for Trunk Pipeline Construction]: "The Technology of Laying 1,420-mm Pipelines Made of Multiple-Layer Pipe"]

[Text] Pipelaying is one of the complicated and important technological operations for erecting the linear portion of arterial pipelines. Given the constantly shifting work front, the builders have to keep an eye continuously on the correct mutual positioning of the operating equipment--above all, on the pipelayers. Moreover, the computed values of the heights for lifting the pipeline in order to insure smooth bending thereof throughout the entire length of the section being laid must be strictly maintained.

Up to now, the process of laying pipelines does not have a special system for instrumented monitoring of observance of the technological parameters. Correctness in conforming with them is determined primarily by visual methods. The brigade leaders' and pipelayer operators' experience have no small role here. However, the reliability of the technological scheme itself occupies a leading place in insuring quality in pipelaying and the effectiveness of its execution.

A correctly prepared and scientifically substantiated technological scheme for doing the pipelaying work enables the probability of breakdowns to be reduced to a minimum and paves the way for continuous construction of the linear portion of arterial pipelines.

When building 1,420-mm diameter pipelines, unvalidated deviations in the outfitting of the erecting column, as is evidenced, for example, in an attempt to reduce the number of pipelayers, can lead to substantial losses, which sharply degrade the quality of the work done. Where there are not enough pipelayers, the probability of them breaking down prematurely rises considerably.

With conversion to the construction of 1,420-mm pipelines, the weight of the pipe and its longitudinal rigidity rose far more than the geometric dimensions. Thus, in comparison with 1,020-mm diameter pipe, the indicators rose 1.8-fold for weight, 3.7-fold for rigidity. This has led to a worsening of the pipeline's "absorbency" into the local relief and also required the adoption of new engineering solutions associated with peculiarities in laying pipelines on the route's turn angles.

The technology of laying 1,420-mm pipe has been mastered well. VNIIST has developed and introduced widely standard technological schemes that are marked by high economy and reliability. However, this relates only to pipelines whose walls are of monolithic cross-section. As for pipelines made of multiple-layer pipe, the standard technological schemes are not entirely acceptable.

Multiple-layer pipe designed by the Institute of Electrical Welding imeni Ye. O. Paton, unlike ordinary pipe, is marked primarily by the fact that expensive steels with scarce alloying additives are not required for producing them.

Multiple-layer pipe possesses higher resistance to avalanche-type destruction. However, in regard to certain indicators of constructional feasibility, such pipe is inferior to ordinary pipe. It is marked by reduced resistance to the effect of the erecting loads (bending moments and local concentrations of forces). Therefore, the possibility of using standard technological construction schemes for laying pipelines made of multiple-layer pipe must be assessed and a quantitative evaluation made of this pipe's load-carrying capability under the conditions of its actual interaction with various load-gripping contrivances.

VNIIST has performed a set of experiments to solve the tasks posed.

At the first stage, pipe that was designed for a working pressure of 7.5 MPa and consisted of four layers of 4.1-mm thickness each was tested. The pipe's total wall thickness in this case was 16.4 mm. The steel pipe's yield point (σ_{Tek}) was 450 MPa. A test lot of 150 pipes was specially manufactured for performing the experiment.

The conditions for conducting the experiments were chosen to take into account the possibility of using several standard schemes for doing the insulating and laying work.

Figure 1 shows the standard technological scheme for doing the insulating work by the divided method. The combine that cleans and insulates the pipeline is set up at the end of the column. The drying furnace is behind the second pipeplayer.

Figure 1. Standard Technological Scheme for Lifting 1,420-mm Diameter Pipeline for Doing Insulation Work by the Divided Method.

The calculated operating distances and heights for lifting the pipeline, in meters:

$$L_1 = 10-15; L_2 = L_3 = 20-30; \text{ and } L_4 = 15-20.$$

$$t_1 = t_2 = 5-7.$$

$$C_1 = 65-70; \text{ and } C_2 = 60-65.$$

$$h_1 = 1.1-1.2; h_2 = 1.4-1.6; h_3 = 1.9-2.2; h_4 = 1.3-1.6 \text{ and } h_5 = 0.8-1.1.$$

KOM. Combination machine for cleaning and insulating the pipeline.

CT. Installation for heating and drying the pipeline.

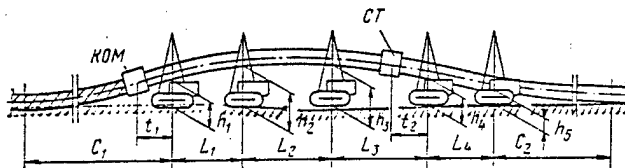

The pipelayers used in the column had a load-lifting capability of 900 kN, and their moment of stability against tipping over was 1,100 kN·m. Standard TP-type trolley suspensions with metal rollers were used as load grippers; the workers' qualifications corresponded completely with the required level. Thus, from the technological point of view, all the necessary conditions were provided for breakdown-free work by the column. Nevertheless, it was found during the work, in the first 100 meters, that damage occurred to the pipeline in several places, in the form of rhomboidal hollows and creases, which resulted from losses of pipe-wall stability during the elastic stage of the working of the metal. In analyzing the scheme's actual parameters that preceded the pipeline breakdown, it was established that the losses of the wall's stability occurred during bending stresses close to 235 MPa, which is 0.52 σ_{Tek} . Ordinary solid-wall pipe does not lose stability even when the stress in its walls is fairly close to the yield point.

Simultaneously with experiments on the route, a series of test operations was carried out in order to study the specific resistance of multiple-layer pipe to the effect of erection loads. At a specially allocated area, welded sections 100-135 meters long were subjected to bending stress under a scheme for a single-span beam with cantilevers. The actual longitudinal (beam) rigidity of pipeline made of multiple-layer pipe, which is $EJ_M = 3.69 \cdot 10^6$ kN·m², was determined. The result obtained was fairly close to that which was computed for cases where the pipe wall has a solid cross-section ($EJ_C = 3.61 \cdot 10^6$ kN·m²); the relative error does not exceed 2.2 percent.

Experiments were carried out on the same welded pipelengths to determine the influence of the type of load-gripping devices on the critical bending stress σ_{kp} , at which multiple-layer pipe loses stability. The pipe was lifted by two pipelayers, which changed their positions, both relative to each other and relative to the welded pipelength. This enabled the parameters of the computed scheme to be varied over a broad spectrum, particularly the stressed state of the pipeline at dangerous cross-sections. Each separate test was completed to pipeline failure, in accordance with the plan. The critical values of stress σ_{kp} were determined in accordance with the value l of the cantilever, that is, according to the distance from the place of the fracture to the nearest end of the pipelength.

The following formula was used for the recalculation

$$\sigma_{kp} = \frac{q l^2 D E}{4 (E J_M)},$$

where q is the weight of a unit of pipeline section, which is determined in accordance with the factory grade of the pipe; D is the pipeline diameter; $D = 1.42$ m; E is the modulus of elasticity of the pipe's steel; $E = 2.1 \cdot 10^5$ MPa; EJ_M is the pipeline's linear rigidity to bending; and $EJ_M = 3.69 \cdot 10^6$ kN·m².

Trolley suspensions with rollers faced with polyurethane and PK-type roller slings were used as load-gripping devices. A portion of the tests was carried out with the use of welded suspensions installed on a crosspiece with an interaxial distance of 2,400 mm.

The critical stresses for multiple-layer pipe under free-bending conditions, that is, without accounting for the effect of local influences on the part of the load-gripping accessories, were assessed separately. The results of the research are shown in the table.

Type of load-gripping device	Critical stresses			
	Minimal, MPa	Maximal, MPa	Averages	
			In absolute value, MPa	Relative to the yield point
Trolley suspension:				
Single.....	215	250	235	0.52
Paired.....	240	280	260	0.58
Roller sling.....	290	330	310	0.69
Free bending.....	280	315	300	0.67

An analysis of the data obtained indicates that the roller slings have an advantage over the trolley suspensions in relation to benefit of interaction with the pipeline. Also, it was established that it is more rational to use paired suspensions than single ones.

The complex of experimental research has enabled certain principles that must be considered in comparing schemes for laying pipe (or insulating and laying) operations with multiple-layer pipe to be evaluated more completely and correctly.

For example, setting up the cleaning and insulating machines in the middle part of the column has enabled the height of lifting of the pipelines at the places where the pipelayers are to be deployed to be reduced considerably and stresses at dangerous cross-sections of the pipeline to be reduced 30-35 percent.

Protection of the insulation coating at the spots where the insulated part of the pipeline rests on the pipelayers' load-gripping devices was insured by the use of roller slings. Figure 2 [not reproduced here] shows one of the stages of execution of laying work on the line by an experienced section, where the pipeline is lowered into the ditch by means of these load-gripping arrangements.

In comparing technological schemes for working with multiple-layer pipe, particularly in determining optimal distances between pipelayers, the fact also was considered that under actual conditions, imperfections of the locality's microrelief, nonsynchronization of individual pipelayer operation by the operators, dynamic influences based upon nonlinearity of the pipeline's axis, and so on, can affect pipeline stress. Each factor can cause the original bend stress to increase 25 percent.

Based upon what has been said, when developing technological schemes for laying (or insulating and laying) work, because of the specific peculiarities of multiple-layer pipe, it is necessary to provide for maximum reduction in bending stresses on the pipeline being laid, to use special load-gripping contrivances of the roller-sling type, to place the cleaning and insulating machine in the middle portion of the column, and to plan the construction strip more carefully.

New schemes for doing insulating and laying work have been developed that take account of these requirements (figure 3).

Figure 3. Technological Schemes for Performing Insulating and Laying Operations in the Construction of 1,420-mm Diameter Pipeline Made of Multiple-Layer Pipe.

- a. Scheme for lifting the pipeline in order to do insulating work by the divided method.
- б. Scheme for laying the pipeline by the divided method.
- в. Scheme for doing the insulating and laying work by the combined method.

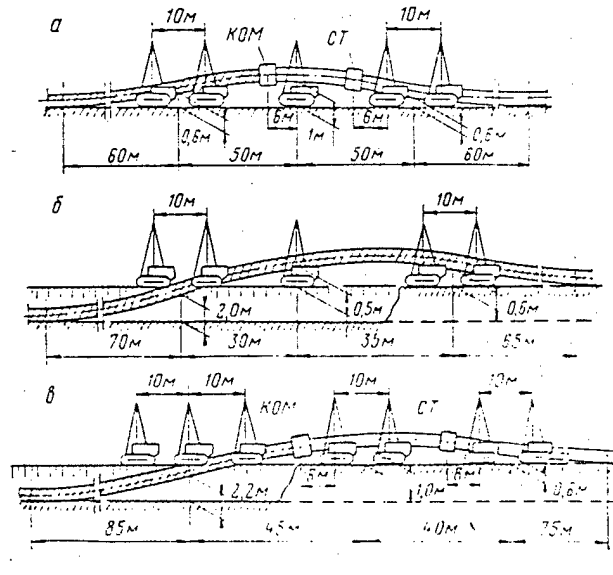

These systems use a grouped arrangement of pipelayers that has advantages (as the calculations indicate) over the uniform arrangement. Such an arrangement provides for a more stable state for the operating scheme itself, and, in so doing, imperfections of the construction strip's microrelief, and also the dynamics of the pipeline on the laying process, are much less telling.

An overall view of an insulating and laying column that is working on the erection of a multiple-layer pipe pipeline is shown in figure 4 [not reproduced here].

When insulating and laying pipeline made of multiple-layer pipe that is designed for a pressure of 10 MPa, the column's composition should include two pipelayers more than the number shown in figure 3. One of them is set up in the rear group, the other in the middle group. It is recommended that all pipelayers use roller slings or paired trolley suspensions as load-gripping rigging. The use of single trolley suspension with rollers in the form of aviation tires also can be used.

Conversion to the use of mill-coated pipe can by rights be considered an important reserve for increasing the organizational and technical reliability of the insulating and laying process. Another no less important aspect of this problem is improvement in the design of the multiple-layer pipe itself. According to a VNIIST proposal, the computed thickness of a layer has been increased from 4.1 mm to 5.4 mm, and actually this thickness will reach 5.7 mm. The first lot of such pipe was sent to one of the routes in West Siberia, where an experimental section of gas pipeline 2.5 km long was built from it in 1982-1983, in the shape of a loop. The total length of the loop, along with a section that was erected from two-layer pipe, reached 3.8 km. This and the other pipe were designed for an operating pressure of 10 MPa. During the

construction of this section, particularly during the insulating and laying operations, no breakdowns of the pipe were noted. This was possible thanks both to the successful execution of a set of scientific research in the area of improving construction technology and to making improvements in the area of designing the multiple-layer pipe itself.

COPYRIGHT: Izdatel'stvo "Nedra" "Stroitel'stvo truboprovodov", 1984

11409

CSO: 1822/348

PIPELINE CONSTRUCTION

UDC 621.643.002.2+624.13

EARTHMOVING FOR LARGE-PIPELINE CONSTRUCTION DISCUSSED

Moscow STROITEL'STVO TRUBOPROVODOV in Russian No 6, Jun 84 pp 18-19

[Article by V. P. Mentjukov, I. A. Borisenkov and I. S. Khetinin of VNIIST [All-Union Scientific-Research for Trunk Pipeline Construction]: "Peculiarities of Earthmoving Work During the Construction of Large-Diameter Pipelines"]

[Text] An increase in the diameter of pipe and, consequently, in its rigidity, weight and buoyancy, has led to changes in the technology and organization of construction of trunk pipelines and structures, not only in regard to the mechanized complexes as a whole but also in regard to the composition of the sets of earthmoving equipment. The optimal set of vehicles and machinery for earthmoving work is determined by the soil conditions of the route and the parameters of the structures made by the earthmovers and of the land strip allocated, and these, in turn, are related to the pipeline diameter, the methods for laying and ballasting it, and the necessity for and the amounts of the recultivation of fertile soil layers.

The labor intensiveness of earthmoving work in erecting large diameter pipe, compared with that of erecting 820-mm diameter pipeline, given similar conditions, is 1.5-fold to 2.5-fold greater, and the work volume rises by 33-217 percent. The width of the allocated land strip is increased 1.08-fold to 1.17-fold. This involves an increase in the area of land recultivation and requires the conduct of additional measures for preserving the environment. At the land being worked, prior to digging the ditch, the fertile soil layer is removed and laid in a separate heap for temporary storage and it is returned after the pipeline has been laid and backfilled.

The construction of ditches on straight-line segments and on segments with a radius of curvature of the pipeline's elastic bending involves large amounts of work for preliminary layout of the construction strip. The amount of earthmoving work increases because of the increase not only of the pipeline's geometric parameters but also because of rigidity and buoyancy. An increase in the radius of the elastic bending of a pipeline of increased rigidity necessitates the excavation of a ditch twice as wide as a straight-line segment at the more elongated turn angles. Nonconformance of the shape of the ditch bottom to the designed value can cause great additional bending stresses in the pipeline that can cause it to fail in operation. Deviation of the ditch bottom's depth level from the designed value during soil excavation

by earthmoving machines should be no more than 10 cm, or--with the blasthole drilling method--20 cm. Incomplete removal of the soil cannot be tolerated. Too great a depth of the ditch should be eliminated by filling it with soft soil.

In laying large-diameter pipe in swamps, where there is either standing or temporary flooding of the land, the water's force of ejection of the pipes, which is proportional to the square of the pipe's diameter, is increased. The use of various types of ballasting devices, which compensate for the effect of this force, requires an increase in the ditch's width to 2.2-fold the diameter of the pipeline being built.

With the construction of 1,420-mm diameter pipeline that is weighted down with reinforced-concrete weights, the ditch should be 3 meters wide and 2.6-3 meters deep on straight-line segments of the route, and still larger on curved segments.

In order to excavate ditches of the indicated dimensions on one working pass, the set of earthmoving machines should be organized to work under the mechanized flow-line method, which will allow a ditch of the prescribed profile to be obtained. VNIIST has scientifically substantiated methods for choosing optimal operating schemes and mechanized complexes for doing the earthmoving work, taking into account the specific natural and climatic conditions of the pipeline arterial segments being built.

The guidance on choosing an optimal technology for doing earthmoving work when erecting the linear part of arterial pipelines (R 361-79) examines various combinations of variants in the use of technological schemes and complexes for specific pipeline diameters and soils along the route, taking into consideration labor intensiveness, the work pace, and the equipping of construction organizations with earthmoving and drilling machinery.

Technological schemes can differ considerably from each other, depending upon the soil's engineering-geology characteristics. When excavating ditches in frozen soils, for weighted pipelines with less than 30.0 MPa strength (figure 1), it is necessary to create first an excavation 0.6-0.8 meters deep (depending upon the required ditch depth) and 6-7 meters wide, with the frozen soil broken up initially by rippers based on the D355A tractor or by other high-powered rippers, with later removal thereof by bulldozers. Then, along one of the edges of the designed profile, a pioneering ditch 1.2 meters wide is dug to a depth down to the designed grade level by ETR-254-01 rotary excavators. At a distance of 0.8-0.9 meter from this ditch, a second ditch of the same dimensions is cut. While building the second pioneering ditch, the first trench is backfilled with soil taken from it. Where necessary, the first ditch is filled in with the excavated soil by means of a bulldozer. Finally, the ditch is excavated to the designed depth with a single-bucket ND-1500 excavator. In excavating the ripped-up soil in both prepared ditches, the excavator simultaneously excavates also the soil block that separates these ditches. Where there are stronger frozen soils in the soil block, blastholes are drilled to a depth of as much as 2.2 meters with BM-253 (or MBSH-321) machines, and they are then loaded up and blasted, ripping up the frozen block of soil.

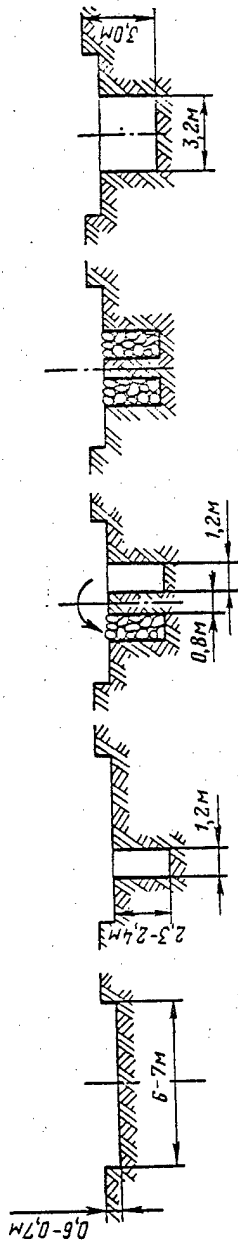

Figure 1. Scheme for Excavating a Ditch in Frozen Soil with Strength of up to 30 MPa.

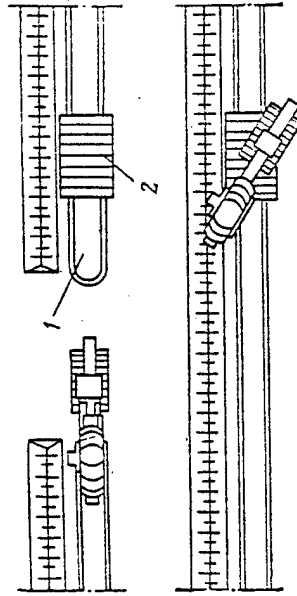

Figure 2. Scheme for Excavating a Ditch with Rotary Excavators under Ordinary Conditions Without Leaving a Barrier Between Increments.

1. Ditch dug by the first excavator.
2. Panels laid by a pipelayer, for exit of the second rotary excavator from the excavation face.

In excavating ditches in firm soils under normal conditions, where the pipeline need not be weighted (figure 2), the ditch width is cut to 2.1 meters but the depth is increased to 2.4 meters. In this case, ETR-254 rotary excavators can dig a ditch of the designed shape in one working pass. Under such circumstances, an increment is singled out for each rotary excavator. Working from behind, the rotary excavator digs out completely its increment without leaving any barrier. The rotary excavator that has excavated the increment goes onto the shoulder, by way of off-the-shelf panels, for transfer to a new increment, or, in a transport mode, it catches up with the working excavator ahead of it and takes its place, while the working excavator that was in front transfers to a new increment in a transport mode.

The cited measures are limiting--different solutions for the technology of the earthmoving operations are found among them, depending upon soil conditions.

The technological schemes worked out here were introduced during construction of the Urengoy-Pomary-Uzhgorod gas pipeline, enabling the pace of earthmoving work to be increased 1.5-fold to 1.8-fold.

COPYRIGHT: Izdatel'stvo "Nedra" "Stroitel'stvo truboprovodov", 1984

11409

CSO: 1822/348

END