

ARMY RESEARCH LABORATORY



Shielding Effectiveness Measurements on Hardened, Transportable Facilities Using Transmission-Line Techniques

Robert Atkinson

ARL-TR-1083

September 1998

Approved for public release; distribution unlimited.

The findings in this report are not to be construed as an official Department of the Army position unless so designated by other authorized documents.

Citation of manufacturer's or trade names does not constitute an official endorsement or approval of the use thereof.

Destroy this report when it is no longer needed. Do not return it to the originator.

Army Research Laboratory

Adelphi, MD 20783-1197

ARL-TR-1083

September 1998

Shielding Effectiveness Measurements on Hardened, Transportable Facilities Using Transmission-Line Techniques

Robert Atkinson

Sensors and Electron Devices Directorate

Reference: The Master Data Exchange Agreement between
the Government of the United States of America
and the Government of France
Annex No. DEA-A-80-F-1265
Title: Nuclear Weapons Effects

Approved for public release; distribution unlimited.

Abstract

As part of science and engineering efforts between U.S. and French personnel, a testbed was devised that demonstrated an alternative approach to evaluating radio-frequency doors. The methods used multiwire transmission lines of the type generally used to perform radiated immunity measurements. Analysis of the results has provided a unique method of determining the electromagnetic susceptibility and long-term hardness-maintenance/hardness-surveillance status of critical command, control, communications, computers, and intelligence (C⁴I) facilities.

Contents

Acknowledgement	v
1. Introduction	1
1.1 Objectives	2
1.2 Personnel	2
2. Background	3
3. Impact of Study	3
4. Methodology	4
4.1 Overview	4
4.2 Transmission-Line Construction and Checkout	5
4.3 Measurement System	8
4.4 Facility and Test Environment	9
4.5 Microstrip Line Construction and Checkout	10
5. Data and Analysis	12
5.1 Environment Within Shield	12
5.2 Microstrip Measurements	13
6. Synopsis	16
Appendix A. Typical Response Data	17
Appendix B. Data File Names and Information	21
Distribution	29
Report Documentation Page	37

Figures

1. DEMOSTHENE	1
2. Schematic representation of transmission line	6
3. Initial TDR response curves for transmission line with six- and seven-wire geometries	8
4. Test and measurement setups	9
5. Typical knife-edge door seam construction	10
6. Microstrip line characteristics	11
7. Measured current on vertical wire	12
8. Measured current on a horizontal wire	13
9. Aperture response characteristics	14
10. Strip line response at six aperture positions	15

Tables

1. List of personnel	2
2. Aperture SE (approximate)	15

Acknowledgement

C'est notre très agréable devoir de présenter les plus vifs remerciements à nos collègues scientifiques du CEG pour leur aide, direction, et amitié, sans lesquels le travail ici décrit n'aurait pu avoir lieu. Nous leur dédions ce rapport.

1. Introduction

A feasibility study was undertaken by the U.S. Army Research Laboratory (ARL) and the Centre d'Etudes de Gramat (CEG) to evaluate the impact of degradation in radio-frequency (rf) shielded door systems that are typically found on tactical, nuclear-survivable command, control, and communications (C³I) shelters. This study took place under Annex DEA-A-80-F-1265, *Nuclear Weapons Effects*, of the Master Data Exchange Agreement (DEA) between the Government of the United States of America and the Government of France.

The study combined a unique approach to electromagnetic, free-field illumination with standard methods for measuring shielding effectiveness (SE) attenuation and degradation for ground-based command, control, communications, computers, and intelligence (C⁴I) facilities. The experiments were conducted at the CEG's DEMOSTHENE facility.

DEMOSTHENE is a French prototype of a mobile C³I facility. It is a modular, shielded structure, designed to ensure the survivability of critical communications equipment to high-altitude EMP (HEMP) effects. DEMOSTHENE (shown in fig. 1) was designed to be transportable by rail and typifies rear-echelon C³I equipment needs. Generally, it would not be found close to the forward edge of the battle area.

Presently, the prototype is set up near CEG's Horizontally Polarized Dipole (HPD) test facility, which is used to evaluate high-altitude electromagnetic pulse (HEMP) effects. Analysis of the experimental results was conducted by ARL personnel at the CEG testbed site and at ARL's Adelphi Laboratory Center, as well as by CEG personnel in France.

Figure 1.
DEMOSTHENE.

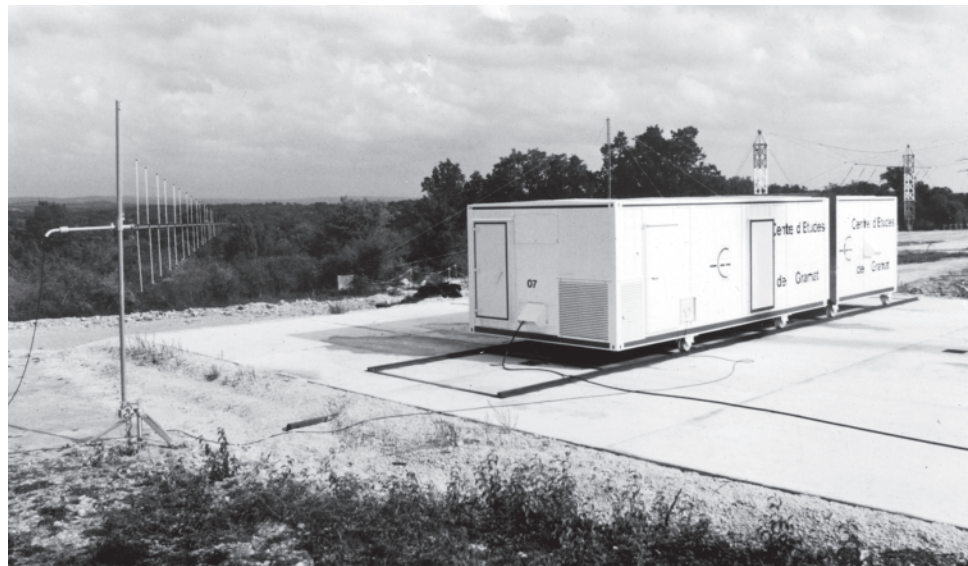

1.1 Objectives

This recent feasibility study focused on an experimental method to evaluate the impact of degradation in rf shielded door systems typically found on tactical, nuclear-survivable C³I shelters.

1.2 Personnel

The personnel responsible for the supervision, conduct, and engineering and technical aspects of these efforts are identified in table 1.

Table 1. List of personnel.

Name	Title	Function
CEG personnel		
Dominique Serafin	Chief	EMP analysis
Michel Bourzeix	Engineer	EMP analysis
Yves Daudy	Engineer	EMP analysis
Jean-Marie Lagard	Technician	EMP analysis
ARL personnel		
Joseph Miletta	Branch chief	EM physics
Robert Atkinson	Engineer	EM physics
John Stewart	Technician	EM physics

2. Background

The Centre d'Etudes de Gramat (CEG) is located in south central France near the town of Gramat, approximately 150 km (92 miles) north of Toulouse. Of the 350 people employed at this 700-acre site, about half are scientists, engineers, and technicians. The CEG Electromagnetic Pulse (EMP) Analysis Group, composed of about 30 people, acted as host for the DEA studies reported here.

The Army Research Laboratory (ARL) is dispersed across three principal locations in the United States, at the Adelphi Laboratory Center (ALC) in Maryland, at the U.S. Army's Aberdeen Proving Ground in Maryland, and at White Sands Missile Range in New Mexico. Members of the Electromagnetic Effects Physics Branch, located at the ALC site, participated with the CEG personnel, both in the performance of the experiments in France and in the follow-on analytical efforts in the United States.

The DEA provides a forum for the technical exchange of nuclear weapons EMP effects, as well as other detrimental electromagnetic effects found on the modern battlefield. In the past, generic studies have been performed by the CEG and ARL groups, both individually and working together under the DEA, to develop techniques, databases, and analytic approaches that support each country's survivability activities.

3. Impact of Study

Although this was not a final study, the findings from the experimental testbed could substantially influence the U.S. Army's present methods for assessing the long-term nuclear hardness maintenance/hardness surveillance (HM/HS) of tactical and strategic systems. Further, the methods developed are applicable to sheltered systems that extensively use lightweight, composite structures to obtain the necessary levels of EMP survivability.

4. Methodology

4.1 Overview

The experimental efforts centered around the design and construction of a testbed demonstration fixture with a large transmission line on the exterior of, and electrically connected to, the DEMOSTHENE facility. The transmission line was placed so that it enclosed one shielded entrance door at the center of the ground plane. The study team easily performed physical adjustments on the transmission line to achieve a 50- Ω geometry (a standard requirement for measurement purposes).

When construction and assembly were complete, the transmission line was energized, and the team characterized the electromagnetic environments within the transmission line and within DEMOSTHENE:

- a. Electric and magnetic (E and H) fields were measured (internal to DEMOSTHENE and within the working volume of the transmission line).
- b. Electric current levels were measured on the return plane of the transmission line; the team used these levels to evaluate the magnitude of injected current and the frequency response of the transmission line, and to provide a reference level for analytical calculations.
- c. Coupling was measured on simple electrical geometries within DEMOSTHENE, such as single wires positioned both horizontally and vertically within the facility at several distances from the shielded door.
- d. Coupling was measured on typical ac power supply lines within the sheltered (and filtered) facility.
- e. Coupling was measured on communications equipment racks in both electrically grounded and ungrounded situations.
- f. Coupling was measured on complex electrical geometries such as those that are typical of equipment interfaces (coaxial cables, general-purpose interface bus (GPIB) cables, and computer ribbon-type cables).

Included in the last group of measurements were both shielded and unshielded cables, loaded (50 Ω) and unterminated, and having both vertical and horizontal cable runs. Measurements were performed for two basic situations: In the first, no degradation to the shielded door gasket was present. In the second, the team simulated degradation by interfering with the electrical connections at the shield door knife-edge interface.

The team constructed a second microstrip line inside the DEMOSTHENE facility to allow for study of the effects of changes in the seam impedance due to degradation in the shielding door gaskets. The microstrip line was positioned vertically over one of the door's long-axis seams.

With the large (exterior) transmission line energized, the voltage response of the microstrip line was measured for various degrees of gasket degradation at several positions along the door seam.

4.2 Transmission-Line Construction and Checkout

A parallel-plate transmission line was selected to be part of the experimental methodology for several reasons: First, the electromagnetic and mathematical theory related to the response characteristics of these devices is widely understood. Second, parallel-plate transmission lines are relatively easy to build and implement. Third, measurements can be made with commercial, off-the-shelf (COTS) equipment using standard, well-documented (and relatively easy to perform) procedures. Combined, these facts implied that if the experiments were successful, the methods could be employed by military maintenance personnel in the field.

Generally, the electrical response of a transmission line is determined by the various aspects of its geometry that affect the characteristic impedance of the line. These aspects include such factors as the length and width of the line, the separation distance between the parallel plates, and how the transitions between the two plates at each end of the line occur. The characteristic impedance of a parallel-plate line can be effectively approximated by

$$Z_0 = \frac{377}{\sqrt{E_r}} \frac{h}{a} \quad , \quad (1)$$

where

$$\begin{aligned} Z_0 &= \text{line impedance,} \\ h &= \text{separation distance between plates,} \\ a &= \text{height of the line,} \\ 377 &= \text{"free-space" impedance, and} \\ E_r &\approx 1. \end{aligned}$$

The formula assumes that one of the two plates acts as an infinite ground plane. It is therefore important to note that as the width of the other plate tends to decrease, the overall line impedance tends to increase.

Since it was desirable to construct a transmission line that could easily propagate radiated signals in a transverse electromagnetic (TEM) mode, the following electrical criteria must also be satisfied:

$$\frac{2\pi h}{\lambda} \ll 1 \quad \text{and} \quad f = \frac{c}{h} \quad , \quad (2)$$

where

$$\begin{aligned} h &= \text{separation distance,} \\ c &= \text{constant speed of light,} \\ f &= \text{frequency of the propagated signal, and} \\ \lambda &= \text{wavelength.} \end{aligned}$$

Initial design considerations for the parallel-plate line included all the pertinent factors that have been previously described, as well as other factors associated with the implementation of the line, such as its physical size and location. As a result, it was determined that placement of the transmission line must necessarily include one of the shielded entrance doors.

The location for the transmission line was selected to be along the long-axis wall of the DEMOSTHENE facility. That exterior wall, which included both the EMP shield and the shielded entrance door, would act as the electrical ground plane for the line. The door was at the center of this ground plane.

The rest of the line was to be constructed primarily of multiple strands of 14-gauge copper wire, laid out in planar fashion, elevated, and parallel with the ground plane. The ground plane and parallel plane of wires were to be electrically connected at the door frame. Further details are shown in figure 2.

Since most measurement equipment requires 50-Ω inputs, it was desirable to achieve a geometry as close to that impedance as possible. However, physical factors such as the necessity of opening and closing the shielded entrance door with the transmission line in place would tend to make a 50-Ω geometry difficult to achieve.

Before construction was begun, the team determined the approximate dimensions for the width of the transmission line ($a = 1.5$ m) and for the separation of the plates ($h = 0.3$ m). Based on those dimensions, the following approximation for the line impedance was calculated (per eq (1)):

$$Z_0 = 377 \times (0.3/1.5) = 75.4 \Omega .$$

Rough estimations for the impedance of the transition areas (e.g., the area where the parallel line begins to taper) were difficult to make. However, by using curvature tables for such geometries, we determined an approximate value of about 100 Ω.

Figure 2. Schematic representation of transmission line.

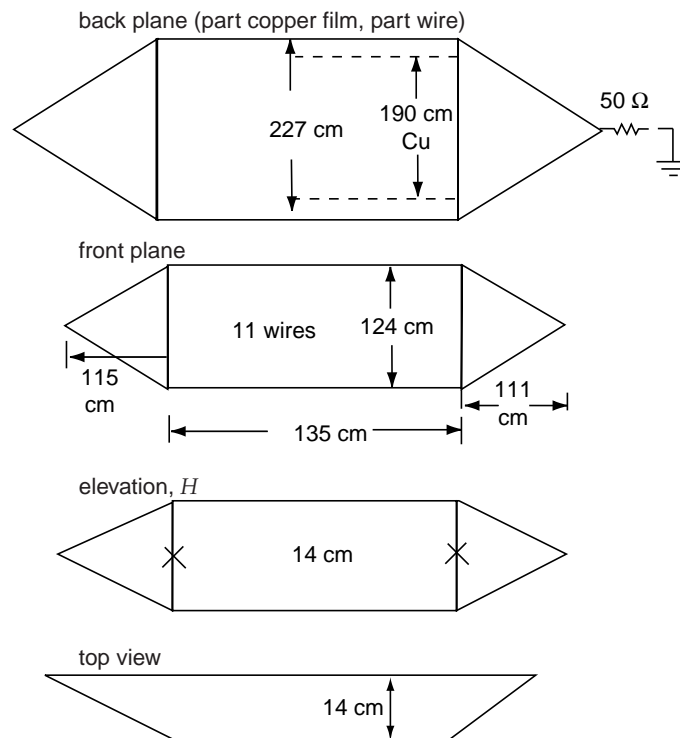

In order to support the transverse electromagnetic (TEM) mode, the following calculation was performed (per eq (2)):

$$f \ll (c/2\pi h) = 159.2 \text{ MHz.}$$

Therefore, the line could theoretically support TEM propagation up to approximately 160 MHz.

Further, if a factor of 10 was assumed as the maximum limit for cutoff, it was reasonable to assume that the bandwidth of the line would be approximately 16 MHz.

Once the basic calculations had been performed and the selection of materials for construction had been determined, the transmission line was assembled on the exterior wall of the DEMOSTHENE. Following this, the team performed a series of experiments to assess the quality of construction and to compare the measured response of the line with the predictions.

Time-domain reflectometry (TDR) measurements provided data that were used to assess the electrical impedance of the line at various locations along that line. Initially, the line's general response was not as expected. The electrical impedance of the center portion of the line was approximately 100 Ω , much greater than predicted by the calculations. Although this impedance value was expected at the transitional areas (i.e., where the line tapered to a point), it was not desirable for several reasons.

First, from a measurement standpoint, the impedance mismatch between the transmission line and the measurement system (100 versus 50 Ω) would make it difficult to obtain reasonably accurate data.

Second, from the standpoint of power delivery, the transmission line was inefficient. Because of the high impedance, as well as the impedance mismatches at the transition areas, much more power would need to be delivered to the line than was previously anticipated.

As a result, the design and construction of the transmission line came under close scrutiny, and various design modifications were considered. There were initially two concerns, both having to do with the use of the copper wire.

When the line was first constructed, seven wires were used to create the transition areas and the center portion of the line parallel to the ground plane. (The center portion of the ground plane was almost entirely the shielded entrance door.)

The first modification to the design was to replace the copper portion of the ground plane with solid sheets of laminated copper foil. This was done in an attempt to reduce the electrical impedance of the transition areas.

Then TDR measurements were again performed. The overall response of the transmission line was much better and began to approach the predicted 75 Ω . We also performed the TDR measurements while varying the

number of wires used, so that we could determine how to improve the electrical response.

As an example, figure 3 displays the observed impedance values for the line when seven- and six-wire geometries were used. Shown on the figure are (1) the beginning of the transmission line and the initial transition, (2) the center of the transmission line and its characteristic impedance, and (3) the termination transition and reflection.

Based upon these measurements, wires were added until physical construction constraints would allow no more. The final geometry used 20 wires and had an electrical impedance of approximately 60Ω along the center section. The termination end of the line was necessarily matched with that resistance value.

4.3 Measurement System

The TDR measurements described above were made on a Hewlett Packard 9573 network analyzer with attached 9753 TDR S1-S2 interface. The test configuration used is shown in figure 4.

Figure 4 also details the test setup used to monitor the electrified conditions of the transmission line, the electromagnetic environment within DEMOSTHENE, and current coupled to the interior wires and cables.

As shown in figure 4, the excitation source used was an Armexel pulse generator with the capability of delivering a 1-ns pulse with approximately 10 W of power. The output of the generator was fed directly into the "drive" end of the transmission line. A low-voltage output from the Armexel was used to synchronize and trigger the HP 5920 oscilloscopes during the data collection process.

Current measurements on a single wire of the transmission line were made with a CT-1 current probe. The output of the probe was transmitted to the oscilloscopes through a wideband fiber-optic link. Further, current coupling data (from both CT-1 and bulk current probes) and E - and H -

Figure 3. Initial TDR response curves for transmission line with six- and seven-wire geometries.

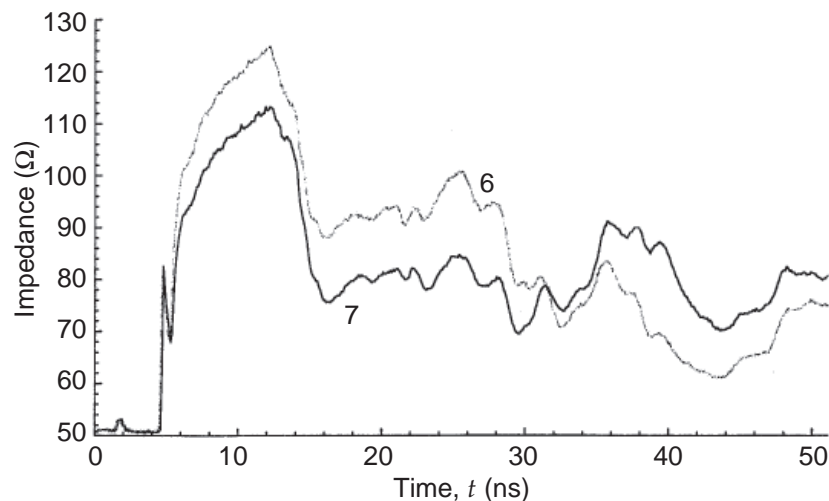

field sensor data were transmitted to the oscilloscopes through a similar fiber-optic system.

Data collection, instrument control, and some basic analytic functions were provided by a computer in an adjacent structure.

4.4 Facility and Test Environment

Of principal concern to the test engineers was the change in the EM environment within the DEMOSTHENE facility caused by flaws and other forms of degradation in the EMP shield.

The facility consisted primarily of two welded structures, joined together by bolts and rf gaskets in a more or less permanent configuration. By welding the structures, the design team ensured that the EMP shield at those areas were of high quality. Although the two sections were joined at a bolted seam, careful planning resulted in a design that maintained the same high-quality shield. Clearly, the areas that would suffer the highest degree of degradation were the entrance doors.

Figure 4. Test and measurement setups (TDR measurement setup and current and field data test setup).

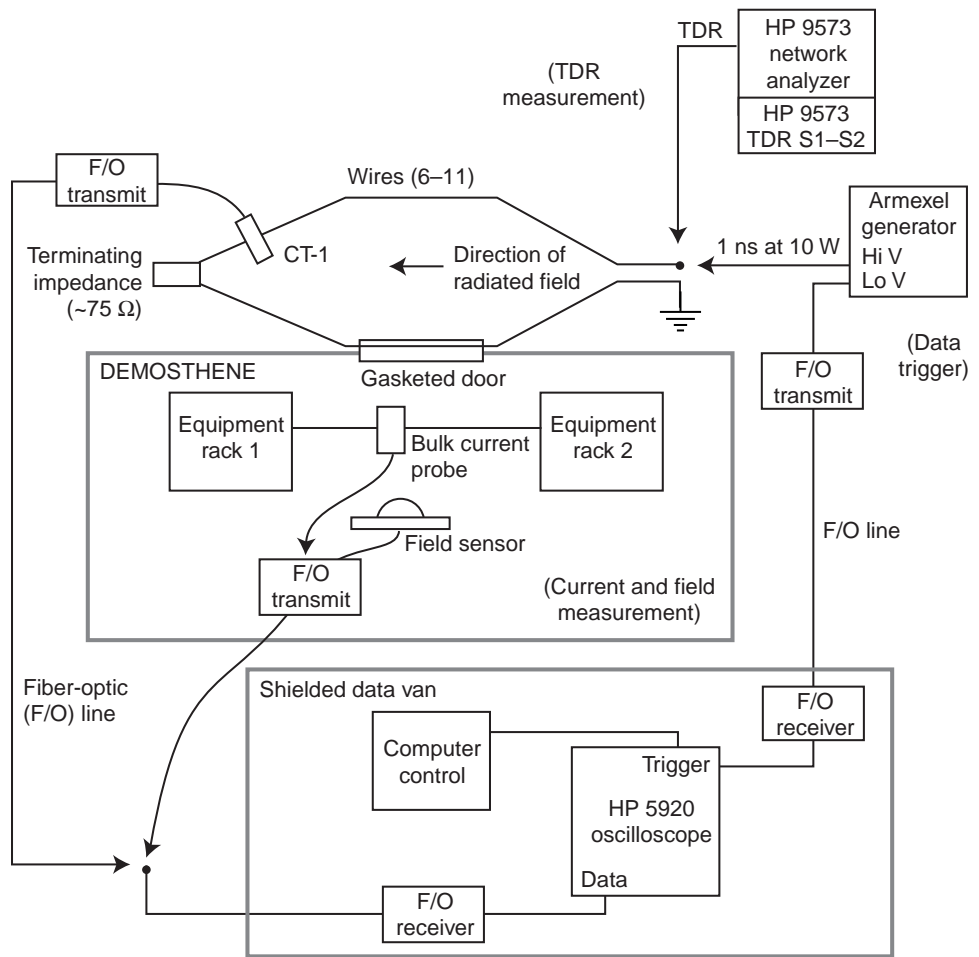

Typically, these features tend to degrade quickly from constant usage. The “finger-stock” type of gasket becomes brittle with age and breaks. The mating edges oxidize with exposure to air. Multiple openings and closings cause the hinge systems to wear out and the doors to seat improperly within the door frame. As a result, the shield could become imperfect and, when excited by an external source, would not provide the necessary SE to protect the internal environment (and equipment) from the most severe external environment.

Because the shielded entrance door was included as part of the parallel-plate transmission line, it was possible to investigate the discontinuities in the EMP shield due to the door as a function of the line’s time-domain response. Also, it was possible to measure the internal environment and to study the changes in that environment when various degrees of door degradation were introduced.

Door degradation was simulated by the insertion of paper (nonconductive) into the door seam interface so that electrical continuity between the knife-edge and the “finger-stock” gasket could not exist (see fig. 5).

As a result, electromagnetic parameters such as the electric field and the magnetic field within the DEMOSTHENE facility could be measured directly with the proper sensor positioning. Indirectly, internal cable coupling could be estimated by measurement of the pickup response on various cables and wires through the use of current probes. These measurements were made on both shielded and unshielded cables. Some of the cables were terminated with $50\ \Omega$ (simulating electrically loaded conditions), and some were not terminated (simulating unloaded conditions). Further, some cables were vertically polarized, and some were horizontally polarized.

The positioning and number of electrical discontinuities indicate changes in the line impedance; one can study these changes by observing the TDR response of the transmission line. We performed additional experiments using a microstrip line within DEMOSTHENE and observing its response to the changes in the externally generated fields.

4.5 Microstrip Line Construction and Checkout

The microstrip line structure was chosen for the experiment because its response characteristics could be easily predicted. As with the larger transmission line, aspects of the smaller line’s geometry (the width and

Figure 5. Typical knife-edge door seam construction.

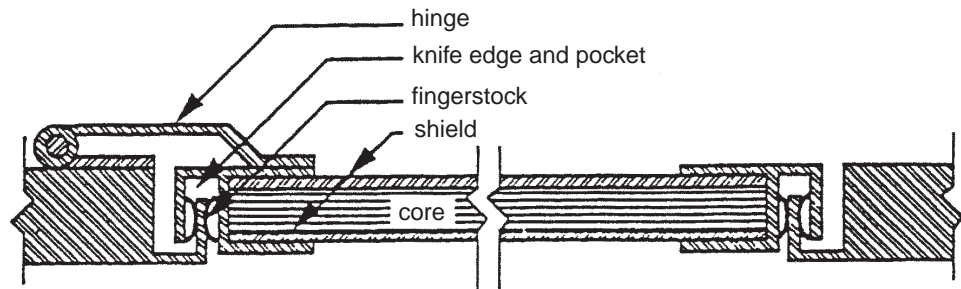

the separation distance from the shield) would determine its characteristic impedance.

What could not be predicted, however, was the reactive response of the line when subjected to different levels of electrical excitation caused by the large, external transmission line. Also unpredictable was the change in the microstrip line response when the area of degradation changed.

Strip-line construction was simple and consisted of nothing more than 5-cm-wide copper tape-foil, elevated above one entrance door seam by nonconductive stops, and terminated to the door frame at one end. The overall length of the strip line was approximately 176 cm. Because of the nonconductive stops, the separation distance between the strip line and the metallic door seam varied greatly along the length of the line. As a result, predicting the impedance for the strip line was difficult.

The separation distance was measured at six positions along the length of the strip line. The distances varied from approximately 1.4 to 2.7 cm. The average separation distance between these two parallel plates was approximately 2.5 cm.

Consequently, the predictions for the line impedance (calculated from eq (1)) yielded about 106Ω at the smaller distance and 204Ω at the larger distance. However, the predictions were inaccurate.

As can be observed from figure 6, the impedance of the line generally varied between 60 and 90 Ω . Most noticeable at the beginning of the TDR on figure 6 is the sharp transition (approximately 210 Ω). This was caused by poor electrical transitioning at the ends. Three termination conditions are also shown in the figure. These include the open-circuit condition (line not terminated), the short-circuit condition (line directly connected to the door frame), and the loaded condition (with 50 Ω). Also indicated on the figure are the approximate positions of the six measured distances.

Figure 6. Microstrip line characteristics.

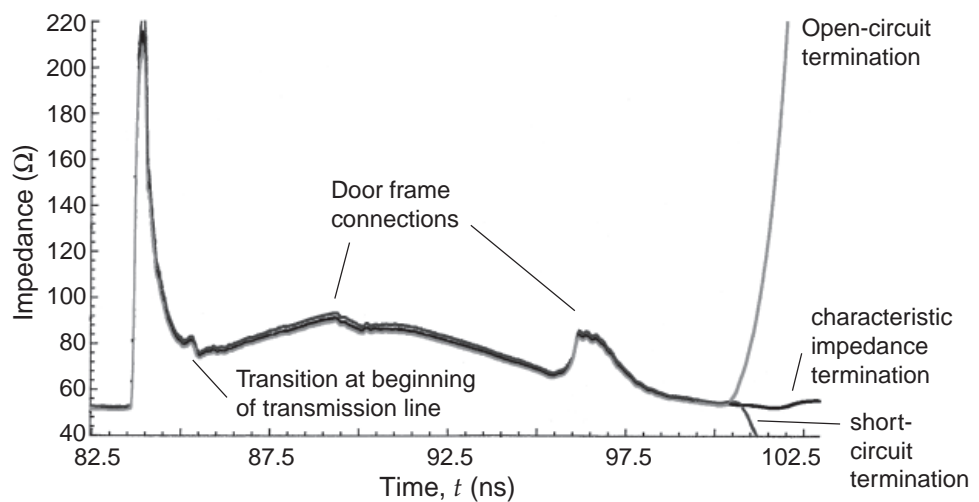

5. Data and Analysis

5.1 Environment Within Shield

To assess the contributions to the interior electromagnetic environment due to the leakage of radiated energy, we examined two test configurations.

In the first configuration, a horizontal copper wire was extended vertically from the ceiling to the floor of the shield. The wire was electrically connected at both ends, and a CT-1 current probe was placed on this makeshift circuit.

The vertical wire was positioned at two locations relative to the door and degraded seam: the first location was 0.5 m from the center of the door; the second position was 1 m from the center of the door. The measured results are shown in figure 7.

Generally, the distance location of the vertical wire had little effect on the amount of signal coupled to the wire. Signal levels indicated an approximate loss of 40 dB in SE between 10 kHz and 10 MHz.

In the second configuration, a horizontal wire was extended across the room, 175 cm away from the shielded door. We simulated degrees of gasket degradation by introducing various lengths of paper into the door seam. Three different lengths were used: 60, 120, and 180 cm.

As before, the wire was electrically connected to the shield at both ends. Current coupled to the wire was again measured with a CT-1 current probe.

As shown in figure 8, the results of increasing the apparent amount of degradation are obvious: as the degraded area was extended, more radiated energy coupled onto the wire.

Figure 7. Measured current on vertical wire.

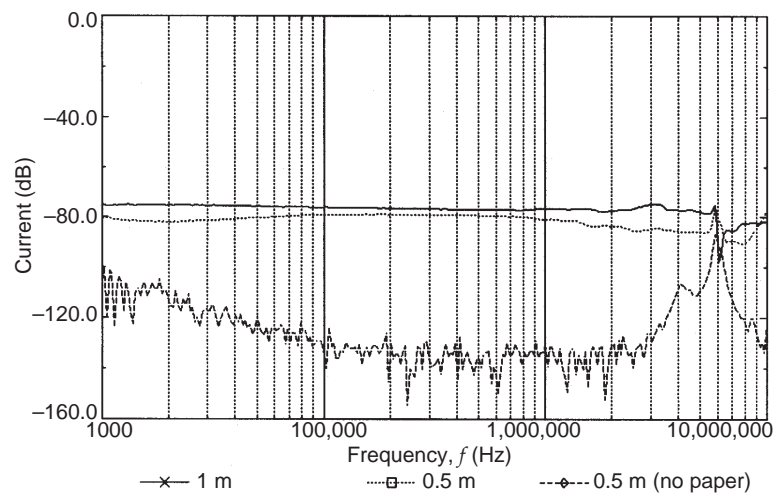
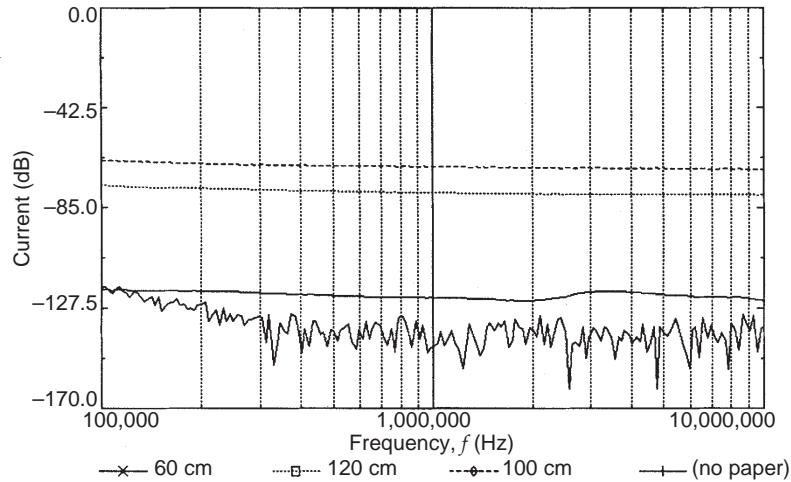

Figure 8. Measured current on a horizontal wire.



5.2 Microstrip Measurements

Before the microstrip line's response was measured, three assumptions were made: First, it was assumed that the external radiated field was uniform across the working volume of the large transmission line. Second, any aperture that was within the working volume would allow the external field to be re-radiated inside the shielded volume. Finally, the locations of the re-radiated field would be detected by the microstrip line.

Since the parallel line was not a single, solid metallic sheet but was composed of 20 wires, slight fluctuations in the radiated field strength were expected. However, the wires were spaced close enough together so that the test engineers were reasonably confident that any fluctuations in field strength were minimized.

If this was the case, then it could be expected that the radiated field strength from the large transmission line, which was at a right angle to the shield, would be equal along the entire length of the door seam. If the door were removed, for instance, the microstrip line would then be subjected to a uniform field along its entire length.

Concerning the second assumption, discontinuities in the transmission line's ground plane (especially at the door seams) should tend to create aperture-like leaks in the EMP shield. Therefore, radiated energy would come through the aperture in a predictable way: generally, the exterior field would be polarized in various ways with the aperture. As shown in figure 9, surface currents that would result from the external field would be interrupted by the aperture.

At low frequencies the currents would tend to flow around the aperture. This would be particularly true if the length of the aperture (L) were much less than the wavelength (λ) of the radiated field. At higher frequencies, the aperture would begin to respond like a coplanar, parallel-plate transmission line. Radiation patterns would begin to occur on the interior of the door seam, which would, in turn, excite the microstrip line. Also, SE corresponding to the slot leakage would result.

Figure 9. Aperture response characteristics: (a) current flow at aperture and (b) internal radiated field.

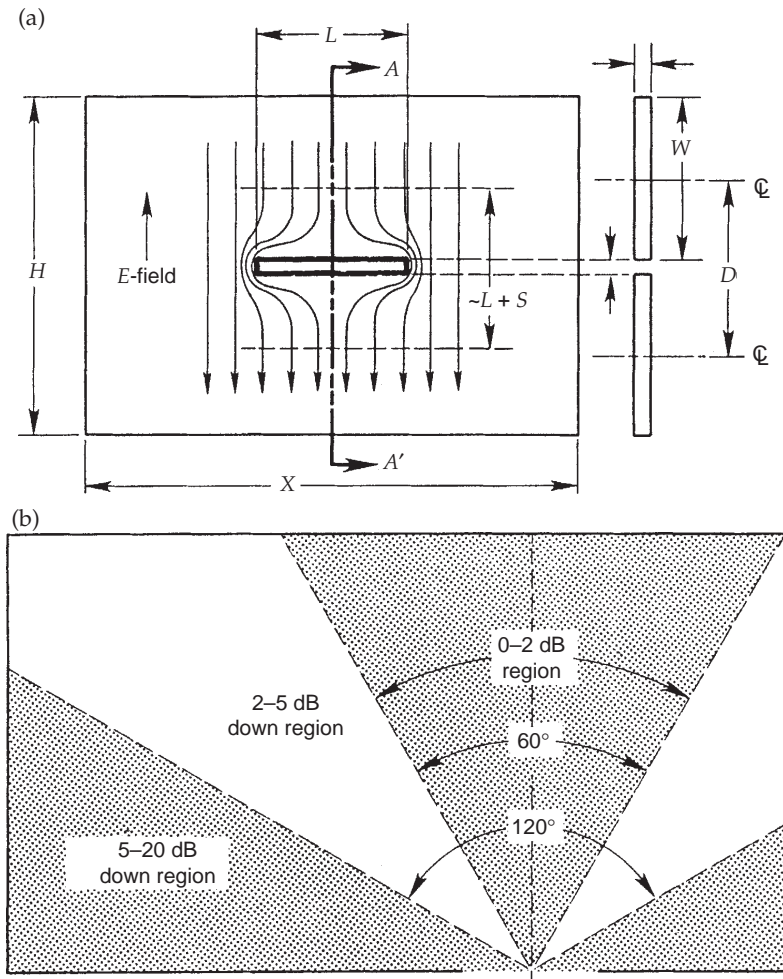

Predictive values for SE at various frequencies were approximated by

$$S_{\text{approx}} = S_{\text{enclosure}} - 10 \log_{10} (LHf_{\text{MHz}}^2) \quad , \quad (3)$$

where

- S_n = SE of DEMOSTHENE (100 dB)
- L = aperture length in millimeters,
- H = aperture height in millimeters, and
- f_{MHz} = frequency in megahertz.

If the length of the aperture was 28 cm (approximately the length of an 8½ × 11 in. piece of paper) and the height of the aperture was 2.5 cm (approximately the thickness of the shield door, or 1 in.), then approximate values for the SE of the aperture would be as shown in table 2.

Therefore, inhibiting the electrical contact along the seam by creating an aperture with the size previously specified, one would expect to see the resulting effects on the response of the microstrip line.

As can be observed from figure 10, the aperture effects were characterized by changes in voltage levels on the strip line. Further, the levels predicted

for the various frequencies closely matched the measured response of the strip line.

Since the strip line was itself a transmission line, it was expected that fields radiating through the aperture might affect the response of the strip line differently as the position of the slot changed. However, this result was not demonstrated by the data.

Figure 10 shows that as the position of the slot changed, changes could be detected in the measured response at the end of the strip line. Unfortunately, the changes were not consistent with the change in location of the aperture.

Table 2. Aperture SE (approximate).

Frequency (MHz)	SE ^a (dB)
0.18	1.5
1.0	61.5
10.0	41.5
100.0	21.5

$$^a[100 - 10 \log_{10} (280 \times 25 \times f_{\text{MHz}}^2)]$$

Figure 10. Strip line response at six aperture positions.

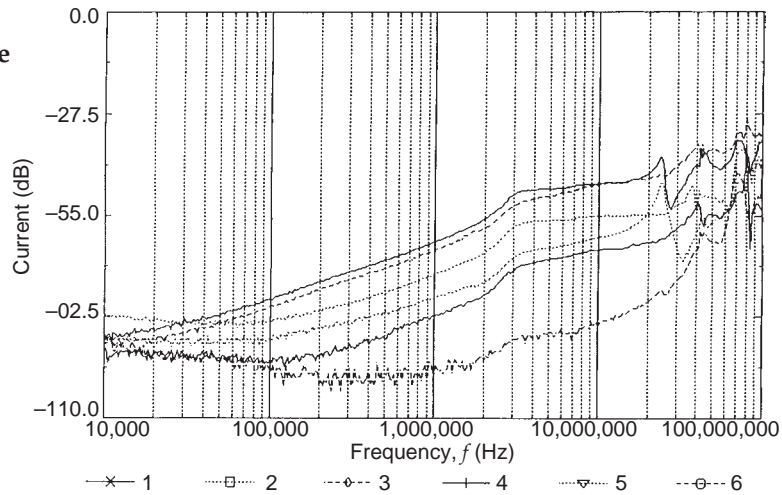

6. Synopsis

This testbed demonstrated a new approach to evaluating the SE of rf-tight doors similar to those typically found on critical ground-based C⁴I facilities. Through analysis of the results of the shielding degradation, both U.S. ARL and French CEG personnel gained insight into the modes and levels of EM coupling resulting from the various degrees of degradation.

In the past, multiwire transmission lines have generally been used to perform rf radiated immunity measurements over a generally wide frequency band. The type, size, and construction of the transmission lines described herein could generate both electric (*E*) and magnetic (*H*) fields. Significant *E*-field propagation, which was predicted before construction and later calculated from internal field measurements, generally ranged between approximately 100 and 200 MHz.

These limitations were, for the most part, due to the physical geometry of the lines. However, additional limitations were imposed by the source generators used to electrically excite the large external lines. Provided a more perfect transmission line were constructed, *E*-field propagation could have extended from approximately 10 kHz to 200 MHz. Hypothetically, *H*-field propagation could have extended up to approximately 1 MHz also. The strength of the fields would have remained dependent on the source voltages.

Despite the limitations, analysis of the transmission-line results has provided a unique approach to determining the long-term nuclear EMP HM/HS status of such facilities. Additionally, the methods used for construction and implementation of the external line could be modified for making radiated immunity measurements to EM fields, such as those described in MIL-STD-462D, *Measurement of EMI Characteristics*.

The internal microstrip line techniques need more investigation. Initial results have indicated that with some modifications these techniques could, as a minimum, be successfully used to verify compliance with regulations such as IEC 801-3, *Electromagnetic Compatibility for Electric and Electronic Equipment—Part 3, Immunity to Radiated RF EM Fields*. Further, the recorded data have supported the idea that areas of rf leakage can be detected with some accuracy, particularly along door seams.

Appendix A. Typical Response Data

Displayed in the following data graphs are various examples of induced currents measured within the DEMOSTHENE facility. These results, obtained inside the shielded volume, were typical examples of data collected during periods when the shielded door was energized by the large transmission line.

Figure A-1. Current on power cord:
(a) horizontally polarized and
(b) vertically polarized.

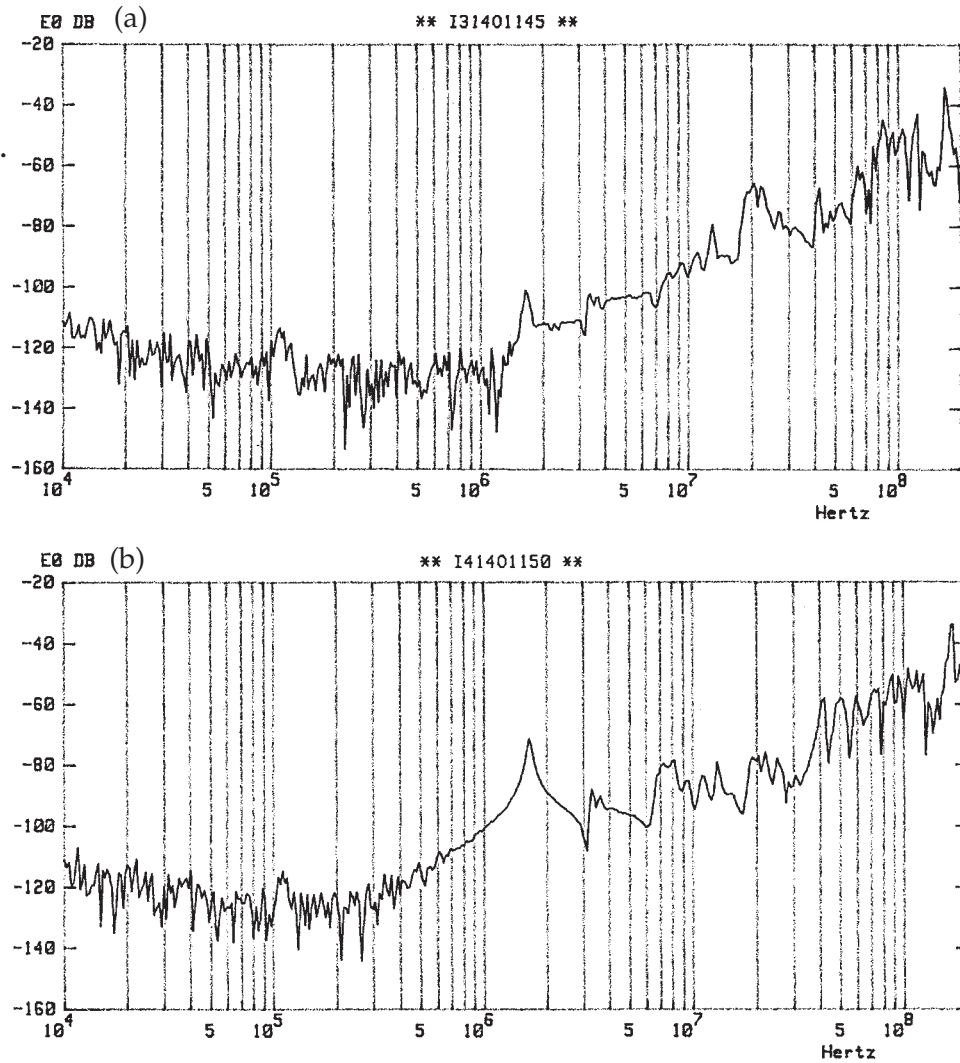

Appendix A

Figure A-2. Current on coaxial cable:
(a) horizontally polarized and
(b) vertically polarized.

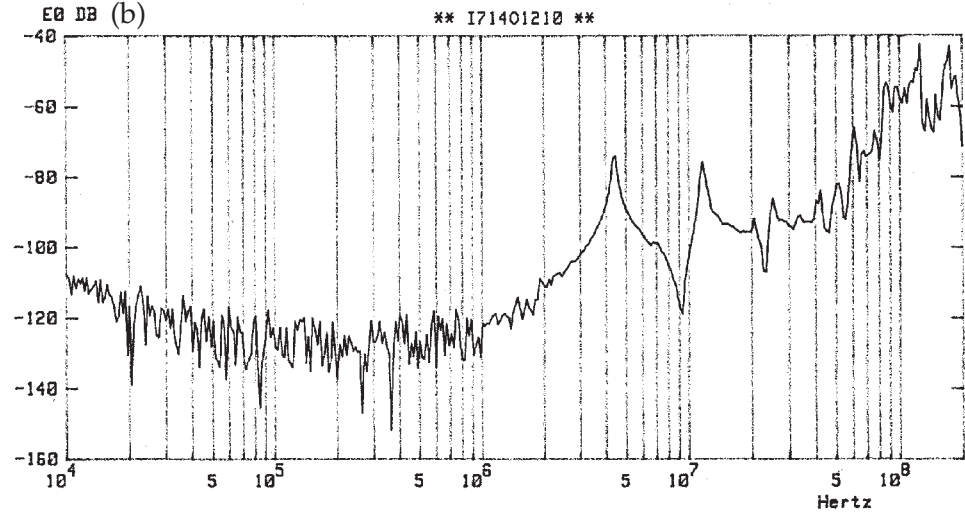
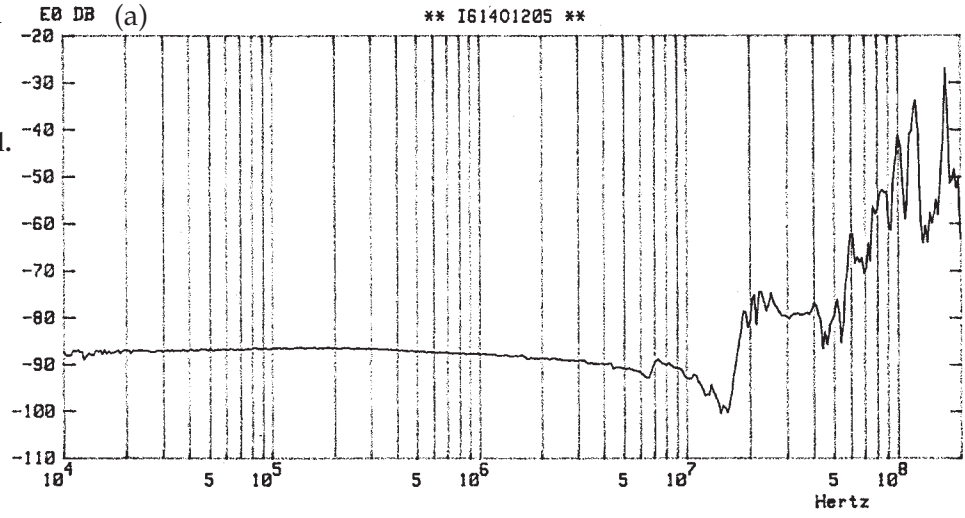

Figure A-3. Current on GPIB cord:
(a) horizontally polarized and
(b) vertically polarized.

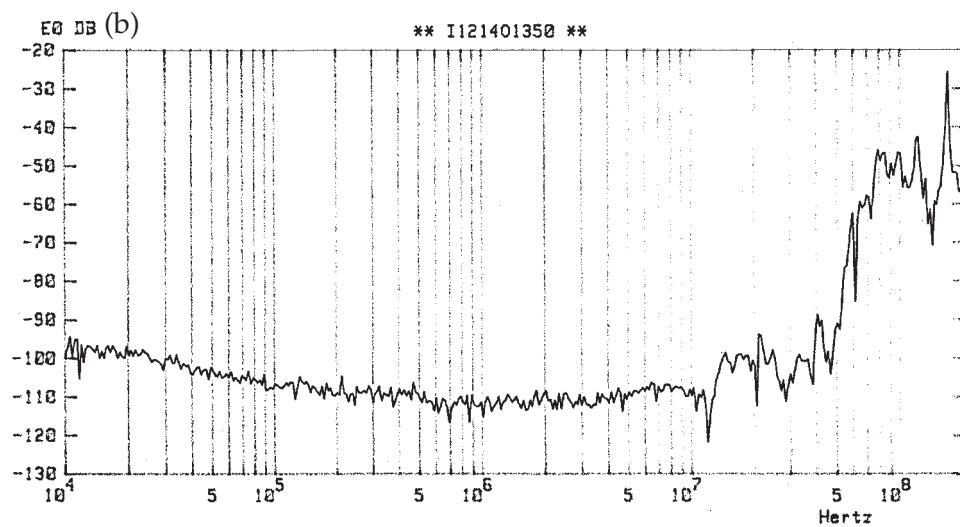
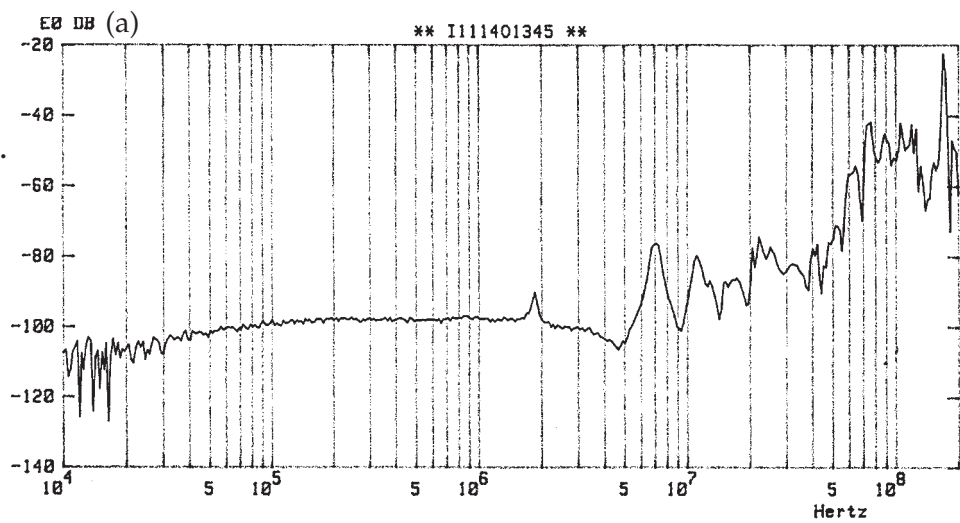

Figure A-4. Current on telephone cable.

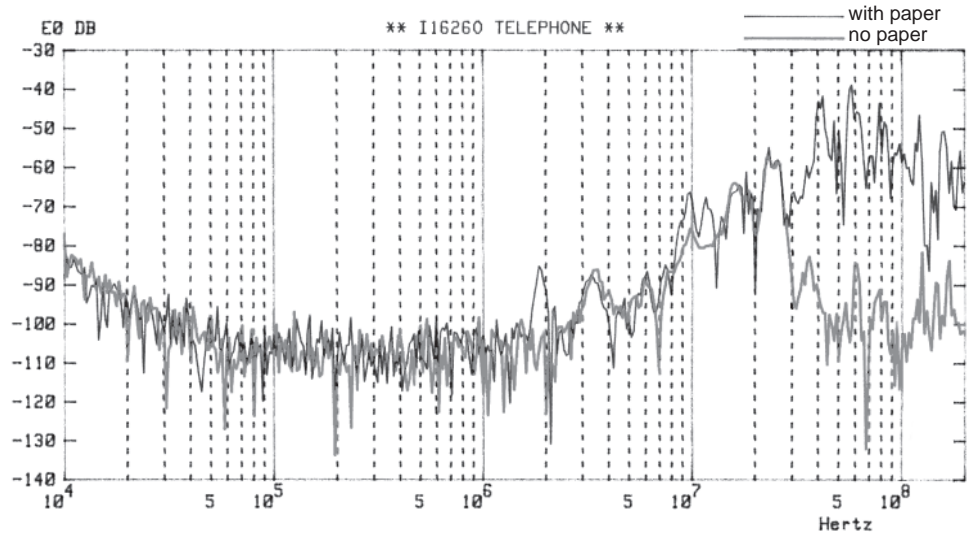

Figure A-5. Current on inter-rack horizontal coaxial cable.

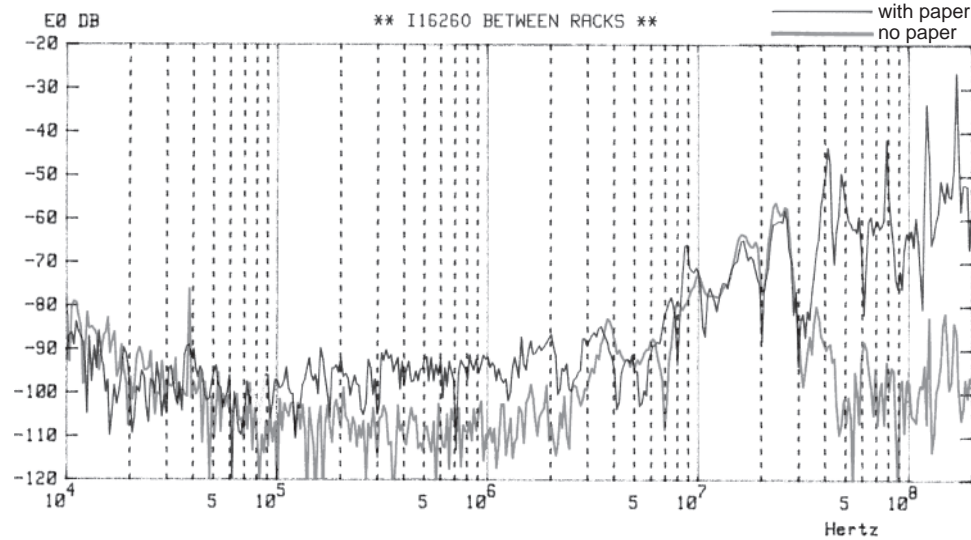
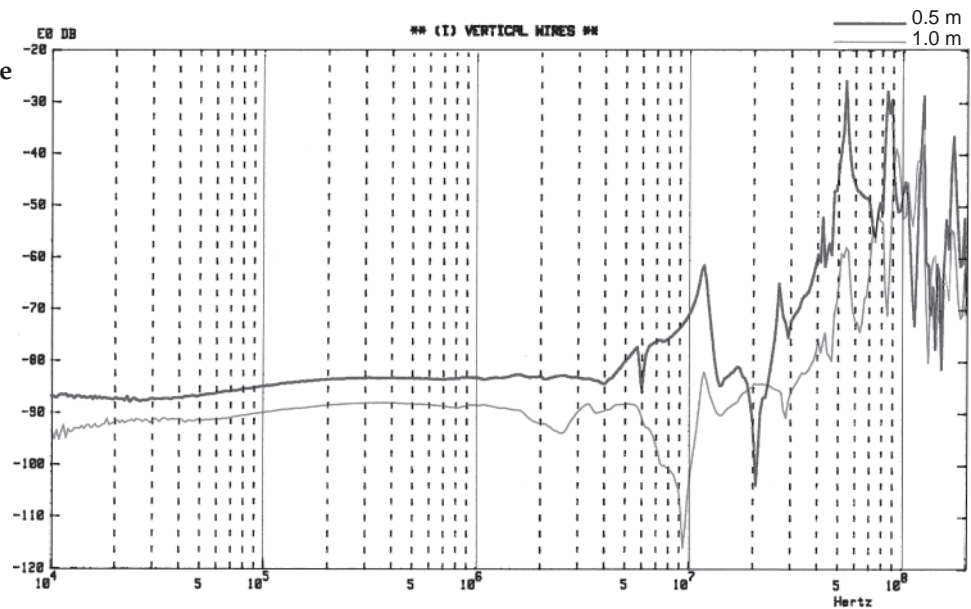

Figure A-6. Current on elevated, vertical single wires at 0.5 and 1.0 m from door.



Appendix B. Data File Names and Information

The following lists the data collected during the experiments at the DEMOSTHENE facility investigating shielding effectiveness. Also included are test-point designations and comments about the physical configurations of test items, personal observations by the test engineers, and the like.

= RECAPITULATIF FICHIERS (données standard AEM) =
=====

```

=====
FICHER | TITRE | XMAX | UNITES | YMIN / YMAX | UNITES |
=====
50OHMTERM | 50OHMTERM | 5.110E-08 Seconds | 4.675E+001/ 1.180E+002 Ohms |
Mesure / TEK11801 | TDR STRIP-LINE TERMINATE 50 Ohms ON RIGHT SIDE OF DEMOSTHENE |
DOOR |
-----
OPENTERM | OPENTERM | 5.110E-08 Seconds | 4.828E+001/ 6.641E+002 Ohms |
Mesure / TEK11801 | TDR STRIP-LINE TERMINATE OPEN CIRCUIT RIGHT SIDE OF DEMOSTHE |
NE DOOR |
-----
SHORTTERM | SHORTTERM | 5.110E-08 Seconds | 6.832E+000/ 1.226E+002 Ohms |
Mesure / TEK11801 | TDR STRIP-LINE TERMINATE SHORT CIRCUIT RIGHT SIDE OF DEMOSTH |
ENE DOOR |
-----
75OHMTERM | 75OHMTERM | 5.110E-08 Seconds | 4.831E+001/ 1.205E+002 Ohms |
Mesure / TEK11801 | TDR STRIP-LINE TERMINATE 75 Ohms RIGHT SIDE OF DEMOSTHENE DO |
OR |
-----
50TERMOD00 | 50TERMOD00 | 5.110E-08 Seconds | 4.242E+001/ 1.194E+002 Ohms |
TEK11801 | TDR STRIP-LINE TERMINATE 50 Ohms RIGHT SIDE OF DEMOSTHENE DOORWITH DO |
OR OPEN |
-----
50OHMTERM6 | 50OHMTERM6 | 5.110E-08 Seconds | 5.035E+001/ 1.134E+002 Ohms |
Mesure / TEK11801 | TDR STRIP-LINE TERMINATE 50 Ohms LEFT SIDE OF DEMOSTHENE DOO |
R |
-----
OPENTERM6 | OPENTERM6 | 5.110E-08 Seconds | 4.967E+001/ 1.845E+002 Ohms |
Mesure / TEK11801 | TDR STRIP-LINE TERMINATE OPEN CIRCUIT LEFT SIDE OF DEMOSTHEN |
E DOOR |
-----
SHORTTERM6 | SHORTTERM6 | 5.110E-08 Seconds | 3.028E+001/ 1.154E+002 Ohms |
Mesure / TEK11801 | TDR STRIP-LINE TERMINATE SHORT CIRCUIT LEFT SIDE OF DEMOSTHE |
NE DOOR |
-----
75OHMTERM6 | 75OHMTERM6 | 5.110E-08 Seconds | 5.049E+001/ 1.133E+002 Ohms |
Mesure / TEK11801 | TDR STRIP-LINE TERMINATE 75 OHMS LEFT SIDE OF DEMOSTHENE DOO |
R |
-----
75OHM6WG | 75OHM6WG | 5.110E-08 Seconds | 5.069E+001/ 1.248E+002 Ohms |
Mesure / TEK11801 | TDR STRIP-LINE TERMINATE 75OHM LEFT SIDE OF DEMOSTHENE DOOR |
6 WIRES |
-----
129S50R1 | 129S50R1 | 5.110E-08 Seconds | 4.659E+001/ 1.148E+002 Ohms |
Mesure / TEK11801 | TDR 50 OHMS RIGHT 7 WIRES FOR 2 PLANES |
=====

```

Appendix B

```

-----
|29S50R2  |29S50R2  | 5.110E-08 Seconds  | 4.425E+001/ 1.071E+002 Ohms
|Measure / TEK11801|TDR STRIP-LINE TERMINATE 50 Ohms RIGHT 7WIRES FOR NAPPE 7+2(
|1/2) WIRES FOR GROUND
-----
|29S50R3  |29S50R3  | 5.110E-08 Seconds  | 4.066E+001/ 9.267E+001 Ohms
|TEK11801|TDR STRIP-LINE TERMINATE 50 Ohms RIGHT 7WIRES FOR NAPPE,7+2 WIRES FOR
|GROUND H=15CM
-----
|29S50R4  |29S50R4  | 5.110E-08 Seconds  | 4.986E+001/ 8.963E+001 Ohms
|TDR STRIP-LINE TERMINATE 50 Ohms RIGHT 7WIRES FOR NAPPE 7+4 WIRES FOR GROUND H
|=15CM
-----
|29SE_V   |29SE_V   | 2.000E+08 Hertz    | -1.243E+002/-5.212E+001 dB
|Measure 3577A/P:B/R|IE/V WITHOUT CALIBRATION (JUST TO SEE THE SHAP)
-----
|29STRANS |29STRANS | 2.000E+08 Hertz    | -6.252E+000/ 4.840E+000 dB
|Measure 3577A/P:B/R| TRANSMISSION STRIP LINE |WITHOUT CALIBRATION (JUST TO SEE T
|HE SHAP)
-----
|29SI_V   |29SI_V   | 2.000E+08 Hertz    | -8.517E+001/-2.555E+001 DB
|Measure 3577A/P:B/R| CURRENT WITH CT1 ON 1 WIRE WITHOUT CALIBRATION (JUST TO SE
|E THE SHAP)
-----
|S11_500HMS|S11_500HMS| 2.000E+08 Hertz    | -4.846E+001/-2.864E+000 dB
|Measure 3577A/P:F2|S11 STRIP-LINE TERMINATE 50 Ohms RIGHT 7WIRES FOR NAPPE 7+4
|WIRES FOR GROUND H=15C
-----
|30S50R5  |30S50R5  | 5.110E-08 Seconds  | 4.899E+001/ 9.127E+001 Ohms
|Measure / TEK11801|TDR STRIP-LINE TERMINATE 50 Ohms RIGHT 7WIRES FOR NAPPE 20 W
|IRES FOR GROUND H=15CM
-----
|30S50R6  |30S50R6  | 5.110E-08 Seconds  | 4.427E+001/ 8.498E+001 Ohms
|TEK11801|TDR STRIP-LINE TERMINATE 50 Ohms RIGHT 13 WIRES FOR NAPPE 20 WIRES F
|OR GROUND H=15CM
-----
|30S50R7  |30S50R7  | 5.119E-08 Seconds  | 4.811E+001/ 9.000E+001 Ohms
|TDR STRIP-LINE TERMINATE 50 Ohms RIGHT 11 WIRES FOR NAPPE 20 WIRES+SHEET 1 PAR
|IT FOR GROUND H=15
-----
|30S50R8  |30S50R8  | 5.119E-08 Seconds  | 4.452E+001/ 9.030E+001 Ohms
|SAME THAN 30S50S7 BUT DOOR OPEN
-----
|01050R9  |01050R9  | 5.119E-08 Seconds  | 4.585E+001/ 8.231E+001 Ohms
|TEK11801|TDR STRIP-LINE TERMINATE 50 Ohms RIGHT 9 WIRES FOR NAPPE 20 WIRES+SH
|EET 2 PART FOR GROUND
-----
|010S11R9 |010S11R9..| 2.000E+08 Hertz    | -5.024E+001/-5.761E+000 dB
|Measure 3577A/P:F2|S11 ON 50 Ohms NAPPE:9 WIRES GROUND:2 CUPPER SHEETS H=15CM
-----
|040R50R11|01050R11 | 5.115E-08 Seconds  | 4.602E+001/ 8.415E+001 Ohms
|TDR TERMINATE 50 Ohms RIGHT 9 WIRES FOR NAPPE 20 WIRES+SHEET 2 PART FOR GROUND
|PAPER ON GASKET
-----
|04050R10 |04050R10 | 5.115E-08 Seconds  | 4.621E+001/ 8.211E+001 Ohms
|TDR TERMINATE 50 Ohms RIGHT 9 WIRES FOR NAPPE 20 WIRES+SHEET 2 PART FOR GROUND
|SAME THAN 01050R9

```

```

-----
|CT1REF7dB |CT1REF7dB| 2.000E+08 Hertz      |-4.520E+001/-1.932E+001 dBvolt
|Measure REFERENCE I WITH CT1 ATT FOL1000=28-21=7dB
-----
|HREF1_CT1 |HREF1_CT1 | 1.000E+07 Hz          | 3.817E+000/ 1.588E+001 A/M
|H=Vs/FT_MGL5(Vs=Mo*Aeq*j*W*H) STORED H/B(B is Vs REF CT1)
-----
|HREF2_CT1 |HREF2_CT1 | 2.000E+08 Hz          | 4.513E-001/ 1.378E+001 A/M
|H=Vs/FT_MGL5(Vs=Mo*Aeq*j*W*H) STORED H/B(B is Vs REF CT1) 2nd BAND
-----
|HREF_CT1  |HREF_CT1  | 2.000E+08 Hz          |-7.791E+000/ 2.569E+001 DBA/M
|Merging HREF1_CT1 AND HREF2_CT1 MAX ERROR ABOUT 1dB AFTER 9MHz
-----
|CT1601020 |CT1601020 | 2.000E+08 Hertz      |-4.339E+001/-1.795E+001 dBvolt
|Measure 3577A/P:A|CT1 REFERENCE FOL1000=28-21=7dB NOTE: NOT SAME AS 5 OCT
-----
|M652601020|M652601020| 2.000E+08 Hertz      | 8.488E-004/ 2.287E-001
|Measure 3577A/P:B/A|MGL5 INSIDE DEMOSTHENE 1M-200MHz WITH PAPER IN GASKET
-----
|M651601020|M651601020| 1.000E+07 Hertz      | 5.788E-003/ 6.595E-001
|Measure 3577A/P:B/A|MGL5 INSIDE DEMOSTHENE 10K-10MHz WITH PAPER IN GASKET
-----
|M651601100|M651601100| 1.000E+07 Hertz      | 8.298E-006/ 1.211E+000
|Measure 3577A/P:B/A|MGL5 INSIDE DEMOSTHENE 10K-10MHz WITH OUT PAPER IN GASKET
-----
|M652601100|M652601100| 2.000E+08 Hertz      | 3.214E-007/ 4.846E-003
|Measure 3577A/P:B/A|MGL5 INSIDE DEMOSTHENE 1M-200MHz WITH OUT PAPER IN GASKET
-----
|CT1601100 |CT1601100 | 2.000E+08 Hertz      |-4.389E+001/-1.931E+001 dBvolt
|Measure 3577A/P:A|CT1 REFERENCE FOL1000=28-21=7dB NOTE: NOT SAME AS 5 OCT
-----
|CT1601145 |CT1601145 | 2.000E+08 Hertz      |-4.468E+001/-1.882E+001 dBvolt
|Measure 3577A/P:A|CT1 REFERENCE FOL1000=28-21=7dB NOTE: NOT SAME AS 5 OCT
-----
|I162601145|I162601145| 2.000E+08 Hertz      | 2.838E-007/ 1.125E-002
|Measure 3577A/P:B/A|I94430_2 I ON TELEPHONE WIRE WITH PAPER IN GASKET
-----
|I162601200|I162601200| 2.000E+08 Hertz      | 1.029E-006/ 4.775E-002
|Measure 3577A/P:B/A|I94430_2 I ON WIRE FROM EQ IN RACK 2 TO EQ IN RACK 3
-----
|CT1601200 |CT1601200 | 2.000E+08 Hertz      |-4.596E+001/-1.827E+001 dBvolt
|Measure 3577A/P:A|Measure 3577A/P:A|CT1 REFERENCE FOL1000=28-21=7dB NOTE: NOT SA
|ME AS 5 OCT
-----
|HIN_CT160 |HIN_CT160 | 2.000E+08 Hz          |-6.409E+001/-5.289E+000 DBA/M
|H INSIDE/Ict1 HALF SLOT WITH PAPER
-----
|I162601530|I162601530| 2.000E+08 Hertz      |-1.339E+002/-5.718E+001 DB
|Measure 3577A/P:B/A|SAME AS I162601145 WITH NO PAPER
-----
|CT1601530 |CT160153  | 2.000E+08 Hertz      |-4.987E+001/-2.140E+001 dBvolt
|Measure 3577A/P:A|REFERENCE FOR I162601530

```

Appendix B

CT1601600	CT1601600	2.000E+08 Hertz	-5.076E+001/-2.171E+001 dBvolt
Mesure 3577A/P:A REFERENCE FOR I162601600			
I162601600	I16201600	2.000E+08 Hertz	4.625E-007/ 1.531E-003
Mesure 3577A/P:B/A Mesure 3577A/P:B/A SAME AS I162601200 WITH NO PAPER			
INOISE1630	INOISE1630	2.000E+08 Hertz	5.166E-009/ 2.871E-006 volt
Mesure 3577A/P:B AMBIENT INSIDE DEMOSTHENE			
CT1801200	CT1801200	2.000E+08 Hertz	-5.852E+001/-1.744E+001 dBvolt
Mesure 3577A/P:A CT1 REFERENCE FOL1000=28-21=7dB NOTE: NOT SAME AS 6 OCT			
IHH801200	IHH801200	2.000E+08 Hz	-7.748E+001/ 5.998E+000 DB
H FIELD POLAR HORIZONTAL MGL6 .5M WITH PAPER (/REF)			
IHN801330	IHN801330	2.000E+08 Hz	-7.619E+001/ 1.105E+001 DB
H FIELD POLAR NORMAL MGL6 .5M WITH PAPER (/REF)			
IHV801345	IHV801345	2.000E+08 Hz	-5.283E+001/ 8.140E+000 DB
H FIELD POLAR VERTICAL MGL6 .5M WITH PAPER (/REF)			
IHV801400	IHV801400	2.000E+08 Hz	-5.946E+001/ 7.168E+000 DB
H FIELD POLAR VERTICAL MGL6 1M WITH PAPER (/REF)			
IHV801415	IHV801415	2.000E+08 Hz	-8.726E+001/ 5.304E+000 DB
H FIELD POLAR VERTICAL MGL6 2M WITH PAPER (/REF)			
IHN801430	IHN801430	2.000E+08 Hz	-7.519E+001/ 1.097E+001 DB
H FIELD POLAR NORMAL MGL6 1M WITH PAPER (/REF)			
IHH801445	IHH801445	2.000E+08 Hz	-8.418E+001/ 6.107E+000 DB
H FIELD POLAR HORIZONTAL MGL6 1M WITH PAPER (/REF)			
IEV801500	IEV801500	2.000E+08 Hz	-4.660E+001/ 4.717E+001 DB
E FIELD POLAR VERTICAL ACD4 1M WITH PAPER (/REF)			
IEN801515	IEN801515	2.000E+08 HZ	-3.248E+001/ 5.533E+001 DB
E FIELD POLAR NORMAL ACD4 1M WITH PAPER (/REF)			
IEH801530	IEH801530	2.000E+08 Hz	-4.443E+001/ 5.063E+001 DB
E FIELD POLAR HORIZOTAL ACD4 1M WITH PAPER (/REF)			
IEH801540	IEH801540	2.000E+08 Hz	-5.875E+001/ 1.305E+001 DB
E FIELD POLAR HORIZONTAL ACD4 .5M WITH PAPER (/REF)			
IEV801545	IEV801545	2.000E+08 Hz	-4.127E+001/ 5.218E+001 DB
E FIELD POLAR VERTICAL ACD4 .5M WITH PAPER (/REF)			
IEN801550	IEN801550	2.000E+08 Hz	-3.146E+001/ 5.254E+001 DB
E FIELD POLAR NORMAL ACD4 .5M WITH PAPER (/REF)			
IEN801600	IEN801600	2.000E+08 Hz	-6.402E+001/ 5.146E+001 DB
E FIELD POLAR NORMAL ACD4 .5M WITHOUT PAPER (/REF)			

```

-----
|CT11200945|CT11200945| 2.000E+08 Hertz      |-4.754E+001/-1.729E+001 dBvolt
|Mesure 3577A/P:A|MESURE REF WITH CT1 FOL 1000 AT 28dB==>28-21=7dB ATTENUATION
-----
|EN1201000 |EN1201000 | 2.000E+08 Hertz      |-6.285E+001/ 2.768E+001 DB
|Mesure 3577A/P:B/A|E NORMAL WITH THOMSON SYSTEME (/CT1) AT 1M
-----
|EV1201010 |EV1201010 | 2.000E+08 Hertz      |-8.097E+001/ 2.188E+001 DB
|Mesure 3577A/P:B/A|E VERTICAL WITH THOMSON SYSTEME (/CT1) AT 1M
-----
|EH1201020 |EH1201020 | 2.000E+08 Hertz      |-5.977E+001/ 3.075E+001 DB
|Mesure 3577A/P:B/A|E HORIZONTAL WITH THOMSON SYSTEME (/CT1) AT 1M
-----
|EH1201030 |EH1201030 | 2.000E+08 Hertz      |-5.734E+001/ 3.497E+001 DB
|Mesure 3577A/P:B/A|E HORIZONTAL WITH THOMSON SYSTEME (/CT1) AT .5M
-----
|EN1201035 |EN1201035 | 2.000E+08 Hertz      |-6.044E+001/ 3.390E+001 DB
|Mesure 3577A/P:B/A|E NORMAL WITH THOMSON SYSTEME (/CT1) AT .5M
-----
|EV1201040 |EV1201040 | 2.000E+08 Hertz      |-7.274E+001/ 2.572E+001 DB
|Mesure 3577A/P:B/A|E VERTICAL WITH THOMSON SYSTEME (/CT1) AT .5M
-----
|HN1201115 |HN1201115 | 2.000E+08 Hertz      |-6.323E+001/-2.315E+001 DB
|Mesure 3577A/P:B/A|N NORMAL WITH THOMSON SYSTEME (/CT1) AT .5M
-----
|HH1201120 |HH1201120 | 2.000E+08 Hertz      |-6.996E+001/-2.451E+001 DB
|Mesure 3577A/P:B/A|H HORIZONTAL WITH THOMSON SYSTEME (/CT1) AT .5M
-----
|HH1201130 |HH1201130 | 2.000E+08 Hertz      |-6.946E+001/-3.821E+001 DB
|Mesure 3577A/P:B/A|H HORIZONTAL WITH THOMSON SYSTEME (/CT1) AT 1M
-----
|HN1201135 |HN1201135 | 2.000E+08 Hertz      |-6.504E+001/-2.698E+001 DB
|Mesure 3577A/P:B/A|H NORMAL WITH THOMSON SYSTEME (/CT1) AT 1M
-----
|HV1201420 |HV1201420 | 2.000E+08 Hertz      |-4.958E+001/-1.305E+001 DB
|Mesure 3577A/P:B/A|H VERTICAL WITH THOMSON SYSTEME (/CT1) AT 1M 265mA/m et H3
|H0 NOT CORRECTED
-----
|HV1201445 |HV1201445 | 2.000E+08 Hertz      |-4.848E+001/-9.109E+000 dB
|Mesure 3577A/P:B/A|H VERTICAL WITH THOMSON SYSTEME (/CT1) AT 0.5M 265mA/m et
|H30 NOT CORRECTED
-----
|CT11201625|CT11201625| 2.000E+08 Hertz      |-1.039E+002/-2.583E+001 DB
|Mesure 3577A/P:B/A|CURRED ON WIRE 0.5M FROM DOOR EXTENDED VERTICAL WITH PAPER
|IN DOOR
-----
|CT11301010|CT11301010| 2.000E+08 Hertz      |-4.587E+001/-2.004E+001 dBvolt
|Mesure 3577A/P:A|REF WITH CT1 FOL 1000 AT 28dB
-----
|CT11301020|CT11301020| 2.000E+08 Hertz      |-9.790E+001/-3.604E+001 DB
|Mesure 3577A/P:B/A|CURRENT ON VERTICAL WIRE AT 1M WITH PAPER IN DOOR
-----
|CT11301045|CT11301045| 2.000E+08 Hertz      |-9.141E+001/-2.975E+001 DB
|Mesure 3577A/P:B/A|CURRENT ON VERTICAL WIRE AT .5M WITH PAPER IN DOOR

```

Appendix B

```

-----
|CT11301100|CT11301100| 2.000E+08 Hertz      |-9.313E+001/-2.783E+001 DB
|Mesure 3577A/P:B/A|CURRENT ON VERTICAL WIRE AT.5M WITH PAPER IN DOOR CT1 ELEVATED
|TED
-----
|CT11301115|CT11301115| 2.000E+08 Hertz      |-8.246E+001/-3.258E+001 DB
|Mesure 3577A/P:B/A|CURRENT ON CT1 CLOSE TO GROUND
-----
|CT11301130|CT11301130| 2.000E+08 Hertz      |-1.153E+002/-1.534E+001 DB
|Mesure 3577A/P:B/A|CURRENT ON CT1 CLOSE TO GROUND WITH 120CM OF PAPER
-----
|CT11301135|CT11301135| 2.000E+08 Hertz      |-1.481E+002/-4.542E+001 DB
|Mesure 3577A/P:B/A|CURRENT ON CT1 CLOSE TO GROUND WITH 60 CM OF PAPER
-----
|CT11301140|CT11301140| 2.000E+08 Hertz      |-1.545E+002/-8.722E+001 DB
|Mesure 3577A/P:B/A|CURRENT ON CT1 CLOSE TO GROUND WITHOUT PAPER
-----
|CT11301405|CT11301405| 2.000E+08 Hertz      |-1.620E+002/-8.866E+001 DB
|B/A|CURRENT ON CT1 CLOSE TO GROUND WITHOUT PAPER ON HORIZONTAL WIRE 175 CM FROM DOOR
-----
|CT11301420|CT11301420| 2.000E+08 Hertz      |-1.536E+002/-8.968E+001 DB
|B/A|SAME AS "CT11301405" WITH CABLE GENERATE THE SIGNAL NOT AT THE GROUND
-----
|NOI1301430|NOI1301430| 2.000E+08 Hertz      |-1.417E+002/-7.237E+001 DBvolt
|Mesure 3577A/P:B|NOISE CABLE GENERATE THE SIGNAL NOT AT THE GROUND
-----
|CT11301445|CT11301445| 2.000E+08 Hertz      |-8.761E+001/-7.868E+000 DB
|B/A|CURRENT ON CT1 CLOSE TO GROUND 180 CM PAPER ON HORIZONTAL WIRE 175 CM FROM DOOR
-----
|CT11301450|CT11301450| 2.000E+08 Hertz      |-1.023E+002/-1.969E+001 DB9dB
|Mesure 3577A/P:B/A|CURRENT ON CT1 CLOSE TO GROUND 120 CM PAPER ON HORIZONTAL WIRE 175 CM FROM DOOR
-----
|CT11301455|CT11301455| 2.000E+08 Hertz      |-1.676E+002/-8.282E+001 DBvolt
|Mesure 3577A/P:B|CURRENT ON CT1 CLOSE TO GROUND 60 CM PAPER ON HORIZONTAL WIRE 175 CM FROM DOOR
-----
|CT11301515|CT11301515| 2.000E+08 Hertz      |-1.325E+002/-3.695E+001 dB
|Mesure 3577A/P:B/A|SAME AS "CT11301135" BUT NO CABLE NOISE
-----
|CT11301540|CT11301540| 2.000E+08 Hertz      |-1.161E+002/-3.886E+001 DB
|Mesure 3577A/P:B/A|SAME AS CT11201625 BUT WITH WIRE AT 1.0M
-----
|I11401125 |I11401125 | 2.000E+08 Hertz      |-1.181E+002/-3.081E+001 DB
|Mesure 3577A/P:B/A|BULK(I) ON AC POWER LINE HORIZONTAL NEAR FLOOR SHIELD 6m LENGTH
-----
|I21401140 |I21401140 | 2.000E+08 Hertz      |-9.364E+001/-3.094E+001 DB
|Mesure 3577A/P:B/A|BULK(I) ON GROUND STRAP BETWEEN TWO RACKS
-----
|I31401145 |I31401145 | 2.000E+08 Hertz      |-1.535E+002/-3.399E+001 DB
|Mesure 3577A/P:B/A|BULK(I) ON POWER CORD HORIZONTAL BETWEEN 3 RACKS 2m LENGTH

```

```

-----
| I41401150 | I41401150 | 2.000E+08 Hertz | -1.441E+002/-3.396E+001 DB
| Mesure 3577A/P:B/A|BULK(I) ON POWER CORD VERTICAL 1RACK 1m LENGTH
-----
| I51401155 | I51401155 | 2.000E+08 Hertz | -1.433E+002/-4.267E+001 DB
| Mesure 3577A/P:B/A|I ON SINGLE CONDUCTOR OF RIBBON CABLE VERTICAL 1RACK .5m LE
| NGTH
-----
| I61401205 | I61401205 | 2.000E+08 Hertz | -1.004E+002/-2.688E+001 DB
| Mesure 3577A/P:B/A|BULK(I) ON HORIZONTAL COAX BETWEEN 3 RACKS h=1m - 2m LENGTH
-----
| I71401210 | I71401210 | 2.000E+08 Hertz | -1.517E+002/-4.243E+001 DB
| Mesure 3577A/P:B/A|BULK(I) ON VERTICAL COAX 1 RACKS 1m LENGTH
-----
| I81401215 | I81401215 | 2.000E+08 Hertz | -1.158E+002/-2.929E+001 DB
| Mesure 3577A/P:B/A|BULK(I) ON "L"SHAPE COAX 2 RACKS 1m LENGTH
-----
| I91401330 | I91401330 | 2.000E+08 Hertz | -1.098E+002/-3.478E+001 DB
| Mesure 3577A/P:B/A|BULK(I) ON HORIZONTAL COAX 2 RACKS 1m LENGTH
-----
| I101401335 | I101401335 | 2.000E+08 Hertz | -1.381E+002/-2.238E+001 DB
| Mesure 3577A/P:B/A|BULK(I) ON VERTICAL RIBBON CABLE 1 RACK .5m LENGTH
-----
| I111401345 | I111401345 | 2.000E+08 Hertz | -1.270E+002/-2.230E+001 DB
| Mesure 3577A/P:B/A|BULK(I) ON HORIZONTAL GPIB BETWEEN 3 RACKS 1.5m LENGTH
-----
| I121401350 | I121401350 | 2.000E+08 Hertz | -1.217E+002/-2.575E+001 DB
| Mesure 3577A/P:B/A|BULK(I) ON VERTICAL GPIB 1 RACK 1.5m LENGTH
-----
| I131401425 | I131401425 | 2.000E+08 Hertz | -8.834E+001/-2.632E+001 DB
| Mesure 3577A/P:B/A|SAME AS I21401140 BUT RACKS GROUNDED
-----
| I141401435 | I141401435 | 2.000E+08 Hertz | -1.373E+002/-2.377E+001 DB
| Mesure 3577A/P:B/A|SAME AS I41401150 BUT RACKS GROUNDED
-----
| I151401445 | I151401445 | 2.000E+08 Hertz | -1.452E+002/-2.980E+001 DB
| Mesure 3577A/P:B/A|SAME AS I71401210 BUT RACKS GROUNDED
-----
| I161401510 | I161401510 | 2.000E+08 Hertz | -1.133E+002/-3.050E+001 DB
| Mesure 3577A/P:B/A|I ON EQUIPMENT RACK GROUND STRAP
-----
| POS2180CT | POS2180CT | 2.000E+08 Hertz | -8.547E+001/-3.524E+001 DB9dBm
| Mesure 3577A/P:B|
-----
| POS3180CT | POS3180CT | 2.000E+08 Hertz | -1.027E+002/-4.035E+001 dBvolt
| Mesure 3577A/P:B|
-----
| POS4180CT | POS4180CT | 2.000E+08 Hertz | -8.957E+001/-3.081E+001 dBvolt
| Mesure 3577A/P:B|
-----
| POS5180CT | POS5180CT | 2.000E+08 Hertz | -9.063E+001/-3.670E+001 dBvolt
| Mesure 3577A/P:B|

```

Appendix B

```
-----  
| POS6180CT | POS6180CT | 2.000E+08 Hertz      | -9.025E+001 / -2.713E+001 dBvolt  
| Measure 3577A/P:B |  
-----  
| POS1180CT | POS1180CT | 2.000E+08 Hertz      | -9.597E+001 / -3.654E+001 dBvolt  
| Measure 3577A/P:B |  
-----  
| POS5R180CT | POS5R180CT | 2.000E+08 Hertz      | -9.067E+001 / -3.621E+001 dBvolt  
| Measure 3577A/P:B | REPEAT OF POS 5  
-----  
| FT_91550_5 | FT_91550_5 | 2.000E+08 Hertz      | 1.999E-001 / 1.520E+000  
| Measure 3577A/P:B/R/D | TRANSFERT FONCTION OF CURRENT PROBE (IMPEDANCE)  
-----  
| TDRMSL_50 | TDRMSL_50 | 1.029E-07 Seconds    | 5.150E+001 / 2.156E+002 Ohms  
| Measure / TEK11801 | 50 OHMS TDR  
-----  
| TDRMSL_OC | TDRMSL_OC | 1.029E-07 Seconds    | 5.099E+001 / 2.473E+002 Ohms  
| Measure / TEK11801 | OPEN CIRCUIT TDR  
-----  
| TDRMSL_SC | TDRMSL_SC | 1.029E-07 Seconds    | 3.654E+001 / 2.253E+002 Ohms  
| Measure / TEK11801 | SHORT CIRCUIT TDR  
-----  
| FT_94430_2 | FT_94430_2 | 2.000E+08 Hertz      | 8.175E-002 / 1.029E+000  
| Measure 3577A/P:B/R/D | IMPEDANCE OF CURRENT PROBE USED FOR TELEPHONE AND COAX(9  
| 4430_2 )  
=====
```

Distribution

Admnstr
Defns Techl Info Ctr
Attn DTIC-OCP
8725 John J Kingman Rd Ste 0944
FT Belvoir VA 22060-6218

Defns Info Syst Agcy
Attn Hdqtrs Lib
701 S Courthouse Rd
Arlington VA 22204-2199

Defns Intllgnc Agcy
Attn DIA-PAA-IA T Gadd
Attn DTI-5A J Coleman
Washington DC 20340-6068

Defns Spec Weapons Agcy
Attn DSWA/ESE D Devany
Attn DSWA/ESE MAJ M Aponte
Attn Kennedy
Attn RAES Elec and Sys Techlogy Div
W Scott
Attn DSWA/PMP-A G Baker
Attn SAAS J Brackett
6801 Telegraph Rd
Alexandria VA 22310-3398

Dept of Defns Joint Chiefs of Staff
Attn J3/STD/C2W LTC B Fredericks
Attn J38-IWCR CAPT L J Schaffner
Attn J38-IWCR H Cabayan
The Pentagon Rm2C861
Washington DC 20301

Dept of Defns Joint Spectrum Ctr
Attn JSC/OP R L Schneider
120 Worthington Basin
Annapolis MD 21402-5064

Joint C2 Warfare Ctr
Attn JC2WC-OTI LTC M Rowell
2 Hall Blvd Ste 217
San Antonio TX 78243-7008

National Communications System
Attn Techlgy & Stand (TS) J Orndorff
701 S Courthouse Rd
Arlington VA 22204-2199

Natl Inst of Stand & Techlgy
Attn Rsrch Info Ctr
Rm 301 Bldg 101
Gaithersburg MD 20899

Ofc of the Dir Rsrch and Engrg
Attn R Menz
Pentagon Rm 3E1089
Washington DC 20301-3080

Ofc of the Secy of Defns
Attn ODDRE (R&AT)
Attn ODDRE (R&AT) S Gontarek
The Pentagon
Washington DC 20301-3080

OSD
Attn OUSD(A&T)/ODDDR&E(R) R J Trew
Washington DC 20301-7100

PM Defns Commctn & Army Trans Sys
Attn ASQM-TSA D Singleton
Attn ASQM-TSA G Christophe
Attn ASQB-TSA J Shields
Bldg 283
FT Monmouth NJ 07703-5605

1111th US Army Signal Batallion
Attn AFSY-SRO Morgan
Attn AFSY-SRO Prottzman
Attn AFSY-SRO Wagner
Attn AFSY-SRL LaVigne
FT Detrick MD 21702-5029

AMCCOM
Attn AMSMC-MAE-WL J M Nall
Rock Island Arsenal
Rock Island IL 61299-6000

AMCOM MRDEC
Attn AMSMI-RD W C McCorkle
Redstone Arsenal AL 35898-5240

CECOM
Attn PM GPS COL S Young
FT Monmouth NJ 07703

Distribution (cont'd)

Dept of the Army
Cncpt Anlys Agcy
Attn Library
8120 Woodmont Ave
Bethesda MD 20014-2797

Dir for MANPRINT
Ofc of the Deputy Chief of Staff for Prsnl
Attn J Hiller
The Pentagon Rm 2C733
Washington DC 20301-0300

Dir USA CECOM SMC
Attn AMSEL-DSA-CCU R VanDeveire
FT Monmouth NJ 07703

DTAO
Attn J W Whitt
5109 Leesburg Pike Ste 317
Falls Church VA 22048

ECAC CH R&D Army Ofc
Attn CA F M Sovaiko
ECAC North Severn
Annapolis MD 21402-1187

Hdqtrs Dept of the Army
Attn DAMO-FDT D Schmidt
400 Army Pentagon Rm 3C514
Washington DC 20301-0460

Hdqtrs Dept of the Army
Attn DAMI-FIT B Smith
Pentagon
Washington DC 20301-1001

Hdqtrs Dept of the Army
Assist Secy of the Army for RD&A
Attn SARD-DOV H Fallin Rm 3E411
The Pentagon
Washington DC 20301-0103

Hdqtrs Dept of the Army
Dep Chf of Staf Oprs & Plns
Attn DAMO-FDI LTC L Heathcox
Rm 2C536 The Pentagon
Washington DC 20301-0460

Hdqtrs Dept of the Army
Ofc of the Assist Secy of the Army Rsrch Dev
& Acqstn Special Programs
Attn SARD-SO COL J Mackin
The Pentagon
Washington DC 20301

Hdqtrs USASC
Attn J Moore
FT Huachuca AZ 85613-5000

Information Resource Ctr
Attn ASHC-IMD-L
Bldg 61801
FT Huachuca AZ 85613

ODUSD(ES)/EQ-CM
Attn M Sullivan
400 Army Navy Dr Ste 206
Arlington VA 22202

PEO (Thad) NATO Sea Sparrow Project Ofc
Attn D Hoffman
2531 Jefferson David Hwy
Arlington VA 22242-5155

PM MILSATCOM
Attn ASQM-CCB J Minken
Attn ASQM-TSA N Fiske
Bldg 909
FT Monmouth NJ 07703-5000

PM-IW
Attn OPS-1 LTC C Hilensbrand
9800 Savage Rd Rm 25076
FT Meade MD 20755

Soldier Sys Cmnd
Attn SSCNC-WSA W Nykvist
Natick MA 01760-5018

US Army Air Defns Artillery Schl
Attn ATSA-ADL M Cochrane
Attn ATSA-CD H Tarkowski
Attn ATSA-TSM-F COL R F Alley
Attn ATSA-TSM-TM COL A R Kreutz Jr
FT Bliss TX 79916-3802

Distribution (cont'd)

US Army ARDEC
Attn AMSTA-AR-AEC-IE N Svendsen
Attn AMSTA-CCL H Moore Bldg 65N
Picatinny Arsenal NJ 07806-5000

US Army Armor Ctr
Attn ATZK-FD COL Kalb
Attn ATZK-FD M Bosemer
Attn ATZK-TS COL C F Moler
FT Knox KY 40121-5000

US Army Aviation & Mis Cmnd
Attn AMSMI-RD-MG R Powell
Attn AMSMI-RD-ST-WF D Lovelace
Attn AMSMI-WS-UB D Barber
Redstone Arsenal AL 35898-5000

US Army Aviation & Troop Cmnd
Aviation Applied Technl Dirctr
Attn SAVRT-R-TV J Woodhouse
Attn AMSDT-R-TI C Fikes
Attn AMSAT-R-TV G Birocco
FT Eustis VA 23604-5577

US Army Avn Ctr & School
Attn ATZQ-TSM-C COL C L Gant Jr
FT Rucker AL 36362-5010

US Army CECOM RDEC Intllgnc & Info
Warfare Dirctr
Attn AMSEL-RD-IE-DS-EC R Troisio
Bldg 2705
FT Monmouth NJ 07703-5211

US Army CECOM RDEC Night Vsn & Elect
Sensors Dirctr
Attn AMSEL-RD-NV-CD-MN W D Lee
Attn AMSEL-RD-NV-TOS E Guckian
Attn AMSEL-RD-NV-OD W Grant
10221 Burback Rd Ste 430
FT Belvoir VA 22060-5806

US Army Edgewood RDEC
Attn SCBRD-TD J Vervier
Aberdeen Proving Ground MD 21010-5423

US Army Elec Proving Ground
Attn STEEP-MT-E B Weeks
FT Huachuca AZ 85613-7110

US Army Engr Ctr & FT Leonard Wood
Attn ATSE-CDT COL Davidson
FT Leonard Wood MO 65483-6620

US Army Field Artillery Schl
Attn ATSF-CD-FDD Walker
FT Sill OK 73503-5600

US Army Hdqtr TRADOC
Attn ATCD-B B Miner
Attn ATCD-GB W Dixon
Attn ATCD-Q COL T F Page
Attn ATCD-HW F Teaford
Attn ATCD-MM G Conrad
FT Monroe VA 23651

US Army Infantry Schl
Attn ATZ-CD COL R Hobbs
Attn ATZB-BV COL T J Strauss
Attn ATZB-FS COL J S Gribschaw
Attn ATZB-TS COL R M Tesdahl
FT Benning GA 31905-5400

US Army Info Sys Engrg Cmnd
Attn ASQB-OTD F Jenia
FT Huachuca AZ 85613-5300

US Army INSCOM
Land Information Warfare Activity
Attn LIWA-APD LTC R Vrtis
8825 Beluah St
FT Belvoir VA 22060-5246

US Army Intllgnc Ctr & FT Huachuca
Attn ATZA-CDA COL T G Chopin
Attn ATZA-CDG MAJ J P Goggin
Attn ATZA-CDJ COL J W Wright
Attn ATZA-CDU COL B H Street Jr
FT Huachuca AZ 85613-6000

US Army Material Cmnd
Smart Weapons Management Ofc
Attn LTC D Stenberg
Redstone Arsenal AL 35898-5000

US Army Materiel Sys Analysis Activity
Attn AMSRL-SL-BL D Bealy
Attn AMXSY-C4I S Chismar
Aberdeen Proving Ground MD 21005-5071

Distribution (cont'd)

US Army Natick RDEC Acting Techl Dir
Attn SSCNC-T P Brandler
Natick MA 01760-5002

US Army Natl Ground Intllgnc Ctr
Attn IAFSTC-RMA T Caldwell
220 Seventh St NE
Charlottesville VA 22901-5396

US Army Nuc & Chem Agcy
Attn MONA-NU R Pfeffer
Attn MONA-TS LIB
7150 Heller Loop Rd Ste 101
Springfield VA 22150

US Army OPTEC
Attn CSTE-ECE-A W Knight
4501 Ford Ave
Alexandria VA 22302-1458

Director
US Army Rsrch Ofc
4300 S Miami Blvd
Research Triangle Park NC 27709

US Army Signal Schl
Attn ATZH-CD D Paul
Attn ATZH-DCD P Kidd
FT Gordon GA 30905-5312

US Army Simulation, Train, & Instrmntn
Cmnd
Attn J Stahl
12350 Research Parkway
Orlando FL 32826-3726

US Army Sp & Strtgc Defns Cmnd
Attn CSSD-AT-C L Altgilbers
Attn CSSD-SL-S I Merritt
PO Box 1500
Huntsville AL 35807-3801

US Army TACOM
Attn ATSTA-OE E Di Vito
Warren MI 48397-5000

US Army Tank-Automtv & Armaments Cmnd
Attn AMSTA-AR-TD M Fisette
Bldg 1
Picatinny Arsenal NJ 07806-5000

US Army Tank-Automtv Cmnd Rsrch, Dev, &
Engrg Ctr
Attn AMSTA-TA J Chapin
Warren MI 48397-5000

US Army TECOM
Attn AMSTE-TA-C D Levin
Aberdeen Proving Ground MD 21005-5055

US Army TECOM
Attn STERT-TE-E-EM J Craven
Redstone Technical Test Center
Huntsville AL 35898-8052

US Army TECOM
Attn STEWS-NE J Meason
Attn STEWS-NE-AA M A Klein
White Sands Missile Range NM 88002

US Army Test & Eval Cmnd
Attn R G Pollard III
Aberdeen Proving Ground MD 21005-5055

US Army TRADOC Analysis Ctr
(TRAC-WSMR)
Attn ATRC-WEA D Mackey
White Sands Missile Range NM 88002-5502

US Army TRADOC Battle Cmnd Lab
Attn ATZL-CDC COL P Lamar
FT Leavenworth KS 66027-5300

US Army Train & Doctrine Cmnd
Battle Lab Integration & Techl Dirctr
Attn ATCD-B J A Klevecz
FT Monroe VA 23651-5850

US Army White Sands Missile Range
Attn STEWS-IM-IS
White Sands Missile Range NM 88002-5506

US Military Academy
Dept of Mathematical Sci
Attn MAJ M D Phillips
West Point NY 10996

USA CECOM
Attn AMSEL-IM-BM-I-L-M
CECOM Office Bldg Rm 6A-10
FT Monmouth NJ 07703

Distribution (cont'd)

Commander
USAISEC
Attn AMSEL-IE-TS H Stacey
FT Huachuca AZ 85613

Nav Air Warfare Ctr-Weapons Div
Attn Code 2186 R Randolph
Attn Code 526E00D M Henderson
China Lake CA 93555-6100

Nav Cmptr & Telecom Cmnd
Attn N512C S Gielarowski
4401 Massachusetts Ave NW
Washington DC 20390

Nav Computer & Telecom Area Master Sta
Attn W Sommerville
500 Center Stret Rm 1
Wahiawa HI 96786-3050

Nav Rsrch Lab
Attn Code 5330 R Ford
Attn Code 5740 J Lawrence
Attn Code 6650 T Wieting
4555 Overlook Ave SW
Washington DC 20375-5000

Nav Surface Warfare Ctr
Attn Code B07 J Pennella
17320 Dahlgren Rd Bldg 1470 Rm 1101
Dahlgren VA 22448-5100

Nav Surface Warfare Ctr
Attn Code F-45 D Stoudt
Attn Code F-45 J Latess
Attn Code F-45 S Moran
Dahlgren VA 22448-5100

NISE East
Attn Code 521RL
Box 1376
Norfolk VA 23501-1376

Air Force Inf Warfare Ctr
Attn AFIWC/SAA C Gilmore
102 Hall Blvd
San Antonio TX 78243-7038

Air Force Rsrch Lab (Phillips Ctr)
Attn PL/WSM M Harrison
3550 Aberdeen Ave SE
Albuquerque NM 87109

Air Force Rsrch Lab (Phillips Ctr)
Attn WSM P Vail
Kirtland NM 87112-5776

Air Force Rsrch Lab (Phillips Ctr)
Attn PL/WS W L Baker Bldg 413
Kirtland NM 87117-5776

Air Force Rsrch Lab (Phillips Ctr)
Attn PL/WST W Walton
Kirtland NM 87117-6008

Air Force Wright Lab
Attn WL/AAWD-1 J McCall
Wright Patterson AFB OH 45433-6503

Defns Intlgnnc
Attn MCQA-4 Dfns Intlgnnc Lib
Bldg 6000 Bolling AFB
Washington DC 20340

Hdqtrs AFSPC/SCXPM
Attn J Kenrick
150 Vanden Berg St Ste 1105
Peterson AFB CO 80914-4340

US Air ForceRome Lab
Attn ERPT T Pesta
Griffiss AFB NY 13441-5700

Lawrence Livermore Natl Lab
Attn L-56 M Bland
Attn Security Officer
Attn Techl Info Dept Lib
PO Box 808
Livermore CA 94550

Los Alamos Natl Lab
Attn M/S H851 R Hoerberling
Attn Security Officer
PO Box 1663 Mail Stop 5000
Los Alamos NM 87545

Distribution (cont'd)

Sandia Natl Lab
Attn Orgn 3141 Reports Acqstn
Attn Techl Lib
Attn Div 1244 L Bacon
PO Box 5800
Albuquerque NM 87185

DARPA
Attn B Kaspar
3701 N Fairfax Dr
Arlington VA 22203-1714

University of Texas ARL Electromag Group
Attn Campus Mail Code F0250 A Tucker
Austin TX 78713-8029

BDM Federal Corp
Attn R Antinone
Attn Security Office
PO Box 9274 Albuquerque Intrntn Airport
Albuquerque NM 87119

Booz, Allen, & Hamilton
Attn L Albright
8283 Greensboro Dr
McLean VA 22102

Directed Technologies Inc
Attn N Chesser
4001 N Fairfax Ste 775
Arlington VA 22203

Hicks & Associates, Inc
Attn G Singley III
1710 Goodrich Dr Ste 1300
McLean VA 22102

J D Engeering
Attn J Dando
3103 Fox Den Ln
Oakton VA 22124

Jaycor
Attn W Crevier
PO Box 3980
Santa Barbara CA 93130

Mission Rsrch Corp
Attn M Bollen
8560 Cinderbed Rd Ste 700
Newington VA 22122

Palisades Inst for Rsrch Svc Inc
Attn E Carr
1745 Jefferson Davis Hwy Ste 500
Arlington VA 22202-3402

SRI Intntl
Attn MS 408-70 G August
333 Ravenswood Ave
Menlo Park CA 94025-3493

The MITRE Corp
Attn Corp Info Svc Bedford Lib
202 Burlington Rd
Bedford MA 01730-1420

CIA
Attn OSWR J F Pina
Washington DC 20505

US Army Rsrch Lab
Attn AMSRL-SL-I D Bassett
Attn AMSRL-WM-MB D Granville
Attn AMSRL-WM-MB W Spurgeon
Aberdeen Proving Ground MD 21005

US Army Rsrch Lab
Attn AMSRL-SL-I E Panuska
Attn AMSRL-SL J Wade
Aberdeen Proving Ground MD 21005-5425

US Army Rsrch Lab
Attn AMSRL-SL-CE J Beilfuss
Attn AMSRL-SL-CM D Farenwald
Edgewood MD 21010-5423

US Army Rsrch Lab
Attn AMSRL-SL-CM E Fioravante
Aberdeen Proving Ground MD 21010-5423

US Army Rsrch Lab
Attn AMSRL-SL-EP A Estorga
Attn AMSRL-SL-EP G Palomino
White Sands Missile Range NM 88002-5513

Distribution (cont'd)

US Army Rsrch Lab

Attn AMSRL-CI-LL Techl Lib (3 copies)

Attn AMSRL-CS-AS Mail & Records Mgmt

Attn AMSRL-CS-EA-TP Techl Pub (3 copies)

Attn AMSRL-D J Lyons

Attn AMSRL-DD J Rocchio

Attn AMSRL-IS-TA H Harrelson

Attn AMSRL-SE J Pellegrino

Attn AMSRL-SE-D E Scannell

Attn AMSRL-SE-DE Reyzer

Attn AMSRL-SE-DP K Kerris

Attn AMSRL-SE-DP R A Kehs

US Army Rsrch Lab (cont'd)

Attn AMSRL-SE-DS J Miletta

Attn AMSRL-SE-DS J Tatum

Attn AMSRL-SE-DS L Jasper

Attn AMSRL-SE-DS R Atkinson (25 copies)

Attn AMSRL-SE-DS T Turner

Attn AMSRL-SE-L R Weinraub

Attn AMSRL-SE-RE Y Lee

Attn AMSRL-SE-RS A Sindoris

Attn LTC P Walczak

Adelphi MD 07283-1197

REPORT DOCUMENTATION PAGE			<i>Form Approved</i> <i>OMB No. 0704-0188</i>	
Public reporting burden for this collection of information is estimated to average 1 hour per response, including the time for reviewing instructions, searching existing data sources, gathering and maintaining the data needed, and completing and reviewing the collection of information. Send comments regarding this burden estimate or any other aspect of this collection of information, including suggestions for reducing this burden, to Washington Headquarters Services, Directorate for Information Operations and Reports, 1215 Jefferson Davis Highway, Suite 1204, Arlington, VA 22202-4302, and to the Office of Management and Budget, Paperwork Reduction Project (0704-0188), Washington, DC 20503.				
1. AGENCY USE ONLY (Leave blank)		2. REPORT DATE September 1998	3. REPORT TYPE AND DATES COVERED Final, 11/94 to 8/95	
4. TITLE AND SUBTITLE Shielding Effectiveness Measurements on Hardened, Transportable Facilities Using Transmission-Line Techniques			5. FUNDING NUMBERS DA PR: AH25 PE: 62120A	
6. AUTHOR(S) Robert Atkinson				
7. PERFORMING ORGANIZATION NAME(S) AND ADDRESS(ES) U.S. Army Research Laboratory Attn: AMSRL-SE-DE email: ratkin@arl.mil 2800 Powder Mill Road Adelphi, MD 20783-1197			8. PERFORMING ORGANIZATION REPORT NUMBER ARL-TR-1083	
9. SPONSORING/MONITORING AGENCY NAME(S) AND ADDRESS(ES) U.S. Army Research Laboratory 2800 Powder Mill Road Adelphi, MD 20783-1197			10. SPONSORING/MONITORING AGENCY REPORT NUMBER	
11. SUPPLEMENTARY NOTES ARL PR: 6WN531 AMS code: 622120.H25		Reference: The Master Data Exchange Agreement between the Government of the United States of America and the Government of France, Annex No. DEA-A-80-F-1265, Title: Nuclear Weapons Effects		
12a. DISTRIBUTION/AVAILABILITY STATEMENT Approved for public release; distribution unlimited.			12b. DISTRIBUTION CODE	
13. ABSTRACT (Maximum 200 words) As part of science and engineering efforts between U.S. and French personnel, a testbed was devised that demonstrated an alternative approach to evaluating radio-frequency doors. The methods used multiwire transmission lines of the type generally used to perform radiated immunity measurements. Analysis of the results has provided a unique method of determining the electromagnetic susceptibility and long-term hardness-maintenance/hardness-surveillance status of critical command, control, communications, computers, and intelligence (C ⁴) facilities.				
14. SUBJECT TERMS Transmission line, TEM, shielding effectiveness, transportable facility			15. NUMBER OF PAGES 43	
			16. PRICE CODE	
17. SECURITY CLASSIFICATION OF REPORT Unclassified	18. SECURITY CLASSIFICATION OF THIS PAGE Unclassified	19. SECURITY CLASSIFICATION OF ABSTRACT Unclassified	20. LIMITATION OF ABSTRACT UL	

DEPARTMENT OF THE ARMY
U.S. Army Research Laboratory
2800 Powder Mill Road
Adelphi, MD 20783-1197

An Equal Opportunity Employer