

AR-010-559

Critical Path Analysis of Command
and Control Support

Mike Davies

DSTO-TR-0678

19981112 039

] APPROVED FOR PUBLIC RELEASE

] © Commonwealth of Australia

OPERATIONAL

Critical Path Analysis of Command and Control Support

Mike Davies

**Information Technology Division
Electronics and Surveillance Research Laboratory**

DSTO-TR-0678

ABSTRACT

The Command and Control (C2) Support Study (C2SS) was established to assess the strengths and weaknesses of ADF C2 support and analyse options for addressing the identified weaknesses. Scope for employing critical path analysis capabilities to assist the C2SS in data management, reporting and analysis has been determined. This document conveys the capabilities and associated opportunities through the use of a collection of unclassified examples based on invented data for a Defence Of Australia scenario used in the C2SS.

RELEASE LIMITATION

Approved for public release

DEPARTMENT OF DEFENCE

DEFENCE SCIENCE AND TECHNOLOGY ORGANISATION

DTIC QUALITY INSPECTED 4

**Reproduced From
Best Available Copy**

AQF99-02-0168

Published by

*DSTO Electronics and Surveillance Research Laboratory
PO Box 1500
Salisbury South Australia Australia 5108*

*Telephone: (08) 8259 5555
Fax: (08) 8259 6567*

*© Commonwealth of Australia 1998
AR-010-559
June 1998*

APPROVED FOR PUBLIC RELEASE

Critical Path Analysis of Command and Control Support

EXECUTIVE SUMMARY

The Command and Control (C2) Support Study (C2SS) was established to assess the strengths and weaknesses of ADF C2 support (C2S) and in Phase III analyse options for addressing the identified weaknesses (inadequacies). Phase II of the C2SS has recently been completed. Scope for employing critical path analysis capabilities to assist the C2SS in data management, reporting and analysis has been determined. This document conveys the capabilities and associated opportunities through the use of a collection of unclassified examples based on invented data for a Defence Of Australia (DOA) scenario used in the C2SS.

Critical path and cost analysis are typically intrinsic features within commercial project management tools. Microsoft (MS) Project was chosen for this investigation owing to its availability and user familiarity. It provides an ability to:

- Construct a hierarchical representation of an ADF scenario or structure with associated C2S inadequacy values and remedial cost figures.
- Employ a flexible model design through the use of sub-projects and C2S primitives.
- Automatically generate and visualise critical areas of C2S inadequacy at various levels of abstraction in the model hierarchy.
- Vary inadequacy values and cost for the purposes of cost-benefit and other analysis.

The benefits of using critical path analysis become increasingly apparent with growth in model complexity. Applying critical path analysis to the C2SS data gathered to date will generate some data management and visualisation benefits but is unlikely to reveal any results that are not already evident. A complex model might consist of the hierarchical breakdown of a scenario into various operational phases and stages therein, introduction of specific agencies associated with each phase and stage, and inclusion of specific command support and telecommunication systems associated with the provision of C2S.

The following structure might be used for the study of C2S in a DOA scenario.

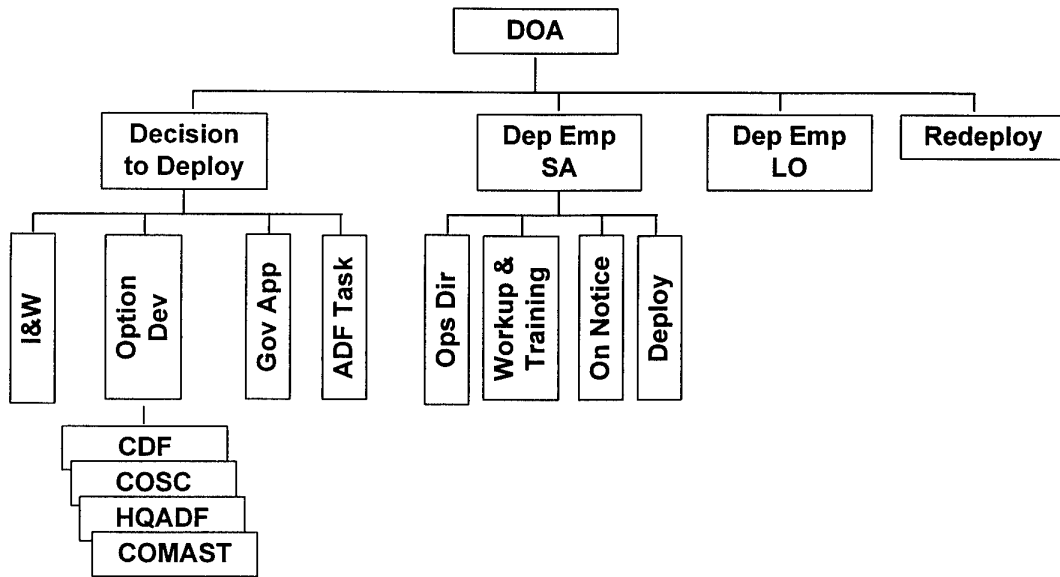

The top-level DOA project for this example is shown below and indicates (for the invented data used) that "the critical inadequacy in C2S occurs during the Decision To Deploy phase".

Item Name	Inadeq	Stack	Unit Cost (\$K/unit)	Inadeq Cost (\$K)
1 DOA	9d	0d	0	512,840
2 <u>Decision to Deploy</u>	9d	0d	0	301,320
3 Deploy & Employ SA	7d	2d	0	136,800
4 Deploy & Employ LAO / Redeploy Pl	8d	1d	0	55,500
5 Redeployment	5d	4d	0	19,220
6				

Drilling through the hierarchical model might present (see figure below) that "the Options Development stage (of the Decision to Deploy phase) is critical owing to inadequate C2S to the contributions of CDF and COMAST". Further interrogation might reveal that the main inadequacies occur in support to the conveyance of commander intent.

The screenshot shows the Microsoft Project interface for 'OPTDEV MPP'. The main window displays a Gantt chart for the 'C2S Model' task. Below the Gantt chart is a task table with the following data:

Task ID	Task Name	Inadeq	Slack	Unit Cost (\$K/unit)	Inadeq Cost (\$K)
1	C2S Model	9d	0d	0	177,270
2	CDF	9d	0d	0	43,120
3	COSC	5d	4d	0	32,800
4	HQADF	6d	3d	0	52,900
5	COMAST	9d	0d	0	48,450

It should be noted that there are dangers in applying quantitative analysis tools to essentially qualitative data. Two values of inadequacy must be comparable for the critical path algorithm to produce meaningful results. 'Apples must be compared with apples' in order to state that a certain C2S layer is critical compared with another because it has a value of 3 and the other 1. This condition is assumed to be satisfied in that even qualitative rating schemes must aim for consistency.

This report is the result of an initial effort to identify opportunities for supporting the C2SS, or some post-study activity, with more quantitative analysis using modelling and simulation.

Author

Mike Davies
Information Technology Division

Mike Davies has a BSc(Hon) in applied mathematics and a PhD in mathematical physics. His career at the DSTO has involved the application of mathematical modelling and computer simulation to the analysis of human performance in ground-based air defence systems and aircraft navigation and weapon delivery. As Head of Systems Simulation and Assessment Group in Information Technology Division his current interests concern the evaluation and enhancement of military Command, Control, Communication and Intelligence through simulation-based analysis and training.

Abbreviations

ADF	Australian Defence Force
C2	Command and Control
C2F	C2 Framework
C2P	C2 Process(es)
C2S	C2 Support
C2SS	C2 Support Study
C/I	Command / Intent
CDF	Chief of the Defence Force
COMAST	Commander Australian Theatre
COSC	Chief Of Staff Committee
CPM	Critical Path Method
DOA	Defence Of Australia
HQADF	Headquarters ADF
I	Inform
I&W	Indicators and Warnings
IM	Information Management
IT	Information Technology
MS	Microsoft
PERT	Program Evaluation and Review Technique
PN	Petri net(s)
T	Telecommunications
Tr	Transformation

Contents

1. INTRODUCTION	1
2. COMMAND AND CONTROL SUPPORT STUDY	1
2.1 Aims.....	1
2.2 Overview of C2S model.....	1
2.3 Assessing C2S.....	3
2.4 Indicative Phase II analysis: Defence Of Australia.....	4
3. SCOPE OF CRITICAL PATH ANALYSIS	5
4. PROJECT MANAGEMENT TOOL CAPABILITIES.....	6
4.1 Representing the basic elements of C2S	7
4.1.1 The project environment	7
4.1.2 Representing the C2S layers	9
4.1.3 Representing the C2 Factors	9
4.1.4 Total model costs and critical inadequacies	10
4.1.5 Critical path analysis.....	10
4.1.6 Cost analysis.....	10
4.2 First cut representation of a full DOA scenario	11
4.3 Modular representation of a full DOA scenario	12
4.3.1 Representing C2S primitives as sub-projects	13
4.3.2 Employing C2S primitives to form a hierarchical DOA model.....	13
5. SCALABILITY: SUPPORTING A MORE DETAILED ANALYSIS	16
5.1 Breaking up the scenario into phases	17
5.2 Representing phases of operation	18
6. SUMMARY AND DISCUSSION OF CAPABILITIES	20
7. CONCLUSIONS.....	21
8. ACKNOWLEDGEMENT.....	22
9. REFERENCES.....	22
APPENDIX A - KEY MS PROJECT UTILITIES.....	23
APPENDIX B - SINGLE PROJECT PRESENTATION OF DOA SENARIO.....	25
APPENDIX C - SHORTCOMINGS IN MS PROJECT CRITICAL PATH ANALYSIS	29

Figures

Figure 1: Layers of C2 Support	2
Figure 2: Transformation/Intent model of C2.....	3
Figure 3: C2 Support data for National Strategic Level of Command	4
Figure 4: C2 Support data for Military Strategic Level of Command	4
Figure 5: C2 Support data for Operational Level of Command.....	5

Figure 6: C2 Support data for Tactical Level of Command5
Figure 7: C2 Support data for Sensor Level of Command5
Figure 8: MS Project representation of C2 Support at National Strategic level8
Figure 9: Revised model of C2 Support at National Strategic level11
Figure 10: Collapsed model of C2 Support for DOA scenario12
Figure 11: Representation of National Strategic Inform factor13
Figure 12: Hierarchical representation of sub-projects for DOA scenario13
Figure 13: Top-level MS Project model of DOA scenario14
Figure 14: Military Strategic sub-project of DOA scenario14
Figure 15: Military Strategic Transform sub-project of DOA scenario15
Figure 16: Operational Transform sub-project of DOA scenario15
Figure 17: Local criticalities for Operational Transform sub-project of
DOA scenario16
Figure 18: Hierarchical representation of sub-projects for detailed
DOA scenario analysis17
Figure 19: Top-level MS Project model of DOA scenario18
Figure 20: The decision to deploy phase of the DOA scenario18
Figure 21: The I&W stage of the DOA scenario19
Figure 22: The Option Development stage of the DOA scenario19

1. Introduction

The Command and Control (C2) Support Study (C2SS)[1,2] was established to assess the strengths and weaknesses of ADF C2 support (C2S) and in Phase III analyse options for addressing the identified weaknesses. Phase II of the C2SS has recently been completed. Scope for employing critical path analysis capabilities to assist the C2SS in data management, reporting and analysis has been determined. This document conveys the capabilities and associated opportunities through the use of a collection of unclassified examples based on invented data for a Defence Of Australia (DOA) scenario.

This report is the result of an initial effort to identify opportunities for supporting the C2SS, or some post-study activity, with more quantitative analysis using modelling and simulation.

2. Command and Control Support Study

2.1 Aims

The aims of the C2SS are[1,2]:

- (a) To assess the extent to which the new ADF Command Arrangements can be supported by the current, planned and government approved ADF C2S capabilities;
- (b) To determine the major capability strengths, limitations, inefficiencies and redundancies in the ADF C2S capabilities; and
- (c) To develop and assess a range of broad options, including indicative costs, which redress identified capability limitations, inefficiencies and redundancies in the ADF C2S capabilities.

Phase I of the study involved scoping of and approach to the study objectives with a conceptual model of C2S being derived. Under Phase II several operational scenarios were examined using the model in order to research and assess ADF C2S capabilities. The study is currently at Phase III where a more general assessment of C2S will be conducted as well as options for addressing C2S inadequacy.

2.2 Overview of C2S model

References 1 and 2 contain details of the conceptual models developed under the C2SS; what follows is an overview. C2 support is represented by 5 layers as shown in Figure 1.

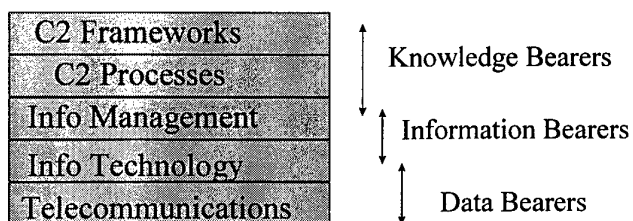

Figure 1: Layers of C2 Support

From reference 1 the definitions of each *Layer of C2S* are:

"The C2 Framework (C2F) bounds and guides the C2 Process (C2P). It outlines the C2 organisation, high level objectives, key positions and responsibilities. A C2 Process addresses how the C2 Framework is implemented. Key sequences of activities are derived and characteristics of how the C2 organisation operates identified.

Information Management (IM) addresses the capture, storage and retrieval of information. C2 Processes are responsible for the manipulation of information. Information Technology (IT) can provide support to the C2 Process and Information Management. Knowledge of C2 Processes may be embedded within computer systems and stored electronic information. Telecommunications (T) permit the transfer of electronic information as data streams."

An effort was made in the C2SS to identify generic characteristics or factors of C2. A Transformation/Intent model of C2 was developed for the C2SS and is shown in Figure 2.

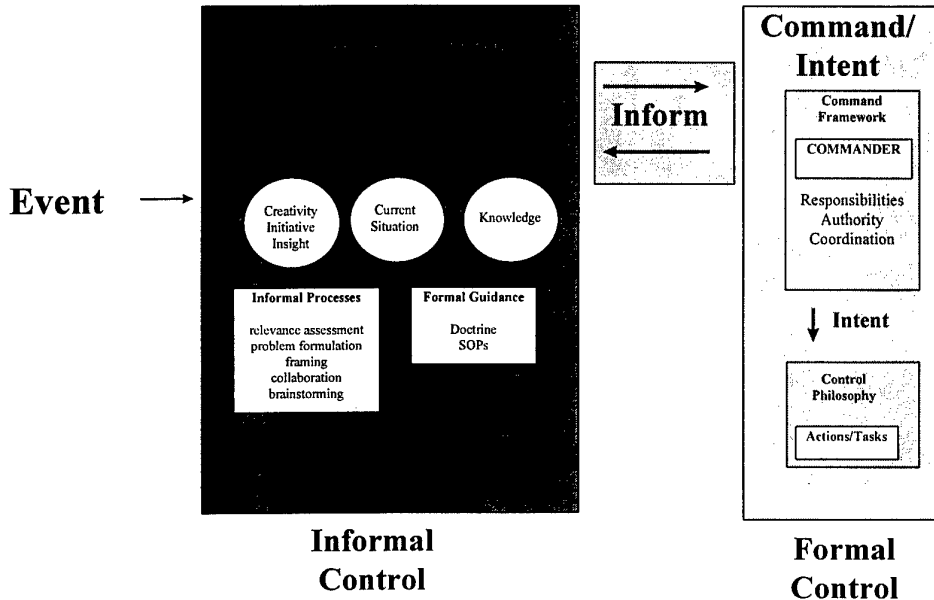

Figure 2: Transformation/Intent model of C2

The C2 model is made up of three C2 Factors[1]:

(i) The Transformation (Tr) Factor concerns the assessment of relevance of events or occurrences. Relevance can be to processes, practices or to commander's intent.

(ii) The Inform (I) Factor is a linking factor concerning the conveyance of assessments.

(iii) The Command/Intent (C/I) factor concerns the exercising of command and the conveyance of intent resulting in the creation of actions and tasks.

2.3 Assessing C2S

In assessing the degree of C2S, the term *Inadequacy* was used where:

$$\text{Inadequacy} = \text{Required level of C2S} - \text{Present level of C2S} .$$

In the case where no C2S was currently present, inadequacy was termed *Critical Absence*. Where some level of C2S was present, inadequacy was referred to as *Insufficient Depth*.

For the considered operational scenarios and elements within, both the required and present levels of C2S were rated between 0 and 3. Values of inadequacy also therefore have the same range. Zero inadequacy indicates that all C2S requirements are satisfied by present levels with a value of 3 corresponding to the highest level of critical absence.

2.4 Indicative Phase II analysis: Defence Of Australia

A mock Defence Of Australia (DOA) scenario will be chosen throughout this report. The data for this scenario has been invented but conveys the nature of the analysis conducted during Phase II of the C2SS[2]. The five levels of command used in the C2SS will be adopted, namely:

- National Strategic;
- Military Strategic;
- Operational;
- Tactical; and
- Sensor.

Figures 3 to 7 show values of inadequacy for each layer of C2 support within each C2 factor of the five levels of command.

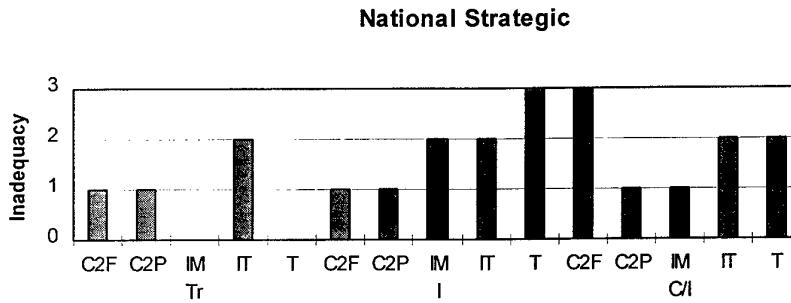

Figure 3: C2 Support data for National Strategic Level of Command

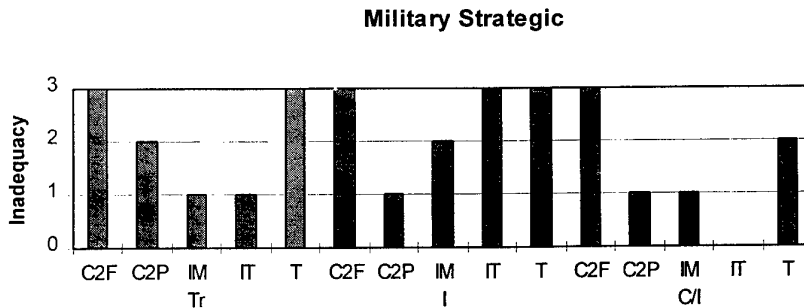

Figure 4: C2 Support data for Military Strategic Level of Command

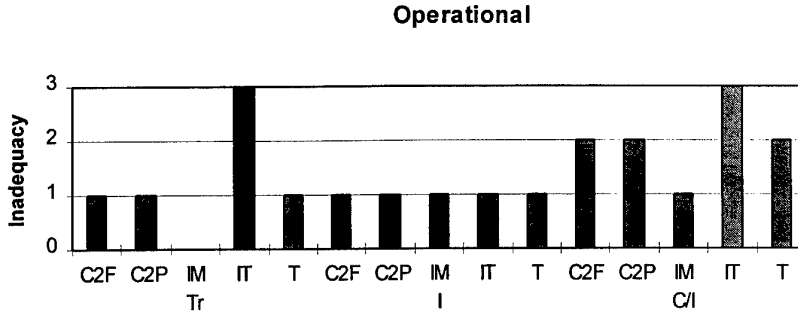

Figure 5: C2 Support data for Operational Level of Command

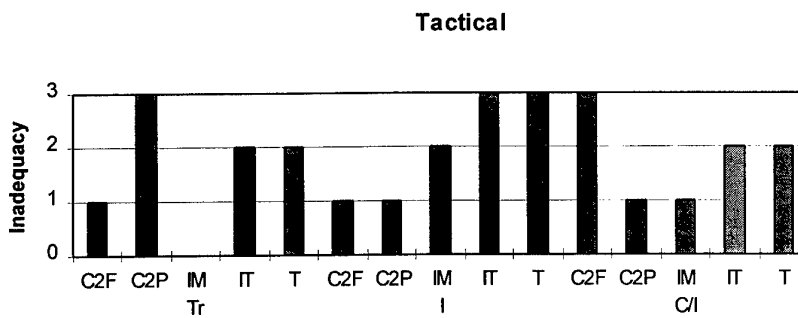

Figure 6: C2 Support data for Tactical Level of Command

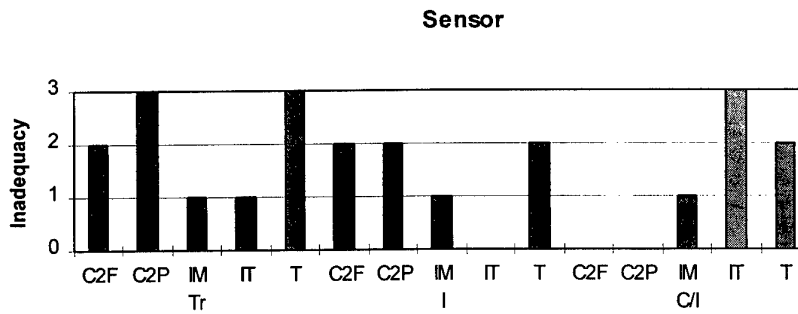

Figure 7: C2 Support data for Sensor Level of Command

3. Scope of Critical Path Analysis

The C2SS identifies the key organisational structures and C2 processes associated with particular scenarios of significance to Australia. It is planned to identify opportunities for complementing the study with more quantitative analysis using modelling and simulation capabilities. In initiating this identification, scope for applying critical path analysis was found.

In its conventional use, the critical path method (CPM) is applied to a time-scaled network of activities (a 'project') in order to determine which activities are critical to the completion over time of that project. Critical activities can be regarded as those activities that have no flexibility in their durations; an increase in duration in such activities results in a direct and equivalent increase in project completion time. Various costs can be associated with an activity, eg fixed costs, resourcing rates, penalties. The CPM acts upon deterministic data; criticalities within projects which involve probabilistic time delays for activities can be inspected using the Project Evaluation & Review Technique (PERT)[4].

Applying the CPM to the C2SS involves using C2S inadequacy values in place of activity duration times in order to identify the corresponding critical areas of C2S. Costs can also be assigned to specific C2S layers and permit some form of cost benefit analysis to be conducted in terms of inadequacy reduction.

There are dangers, however, in applying quantitative analysis tools to what is essentially qualitative data. Two values of inadequacy must be comparable for the critical path algorithm to produce meaningful results. 'Apples must be compared with apples' in order to state that a certain C2S layer is critical compared with another because it has a value of 3 and the other 1. This condition is assumed to be satisfied in that even qualitative rating schemes must aim for consistency.

An important part in realising the benefits of this capability will be addressing the C2SS scenarios in more detail. Applying critical path analysis to C2SS data conveyed in reference 2 will generate some data management and visualisation benefits but is unlikely to reveal any results that are not already evident.

Two implementation technologies were considered; a commercial project management tool and Petri net simulation. The former offers a more complete and user-friendly environment and for this reason was chosen to convey the critical path analysis capability.

4. Project Management Tool Capabilities

A commercial project management tool is generally heavily tailored to conventional projects involving tasks with durations of time. Microsoft (MS) Project is one such commercial product. In order to apply such a product to the study of C2S, the parameter 'time' needs to be replaced with 'inadequacy' which necessitates tailoring and the adoption of certain equivalencies in terminology which are displayed in Table 1. In the remainder of this report the C2S terminologies will be mainly used.

MS Project Terminology	Equivalent C2S Terminology
<p>Tasks (Can be work items, milestones, summary tasks, ...)</p> <p>Day</p>	<p>Model Items (Representing C2S Layers, C2 Factors, ...)</p> <p>Unit Inadequacy</p>
<p>Task Duration (days)</p> <p>Total Duration (days) (Calculated for projects, sub-projects and summary tasks)</p>	<p>Inadequacy (Entered for each C2S Layer)</p> <p>Critical Inadequacy (Calculated for whole C2S model or components within)</p>
<p>Resource Cost (\$ per day)</p> <p>Task Cost (\$)</p> <p>Total Cost (\$) (Calculated for projects, sub-projects and summary tasks)</p>	<p>Unit Cost (\$K per unit Inadequacy) (Cost of Addressing Inadequacy) (Entered for each C2S Layer)</p> <p>Inadequacy Cost (\$K) (Calculated for each C2S Layer)</p> <p>Total Inadequacy Cost (\$K) (Calculated for whole C2S model or components within)</p>

Table 1: Terminology equivalence between project management tools and C2S model

In order to convey the potential applicability of MS Project to the C2SS, a subset of the DOA scenario will be represented first followed by a full representation.

4.1 Representing the basic elements of C2S

4.1.1 The project environment

Figure 8 shows the MS Project representation of the National Strategic component of the DOA scenario data; ie that conveyed in Figure 3.

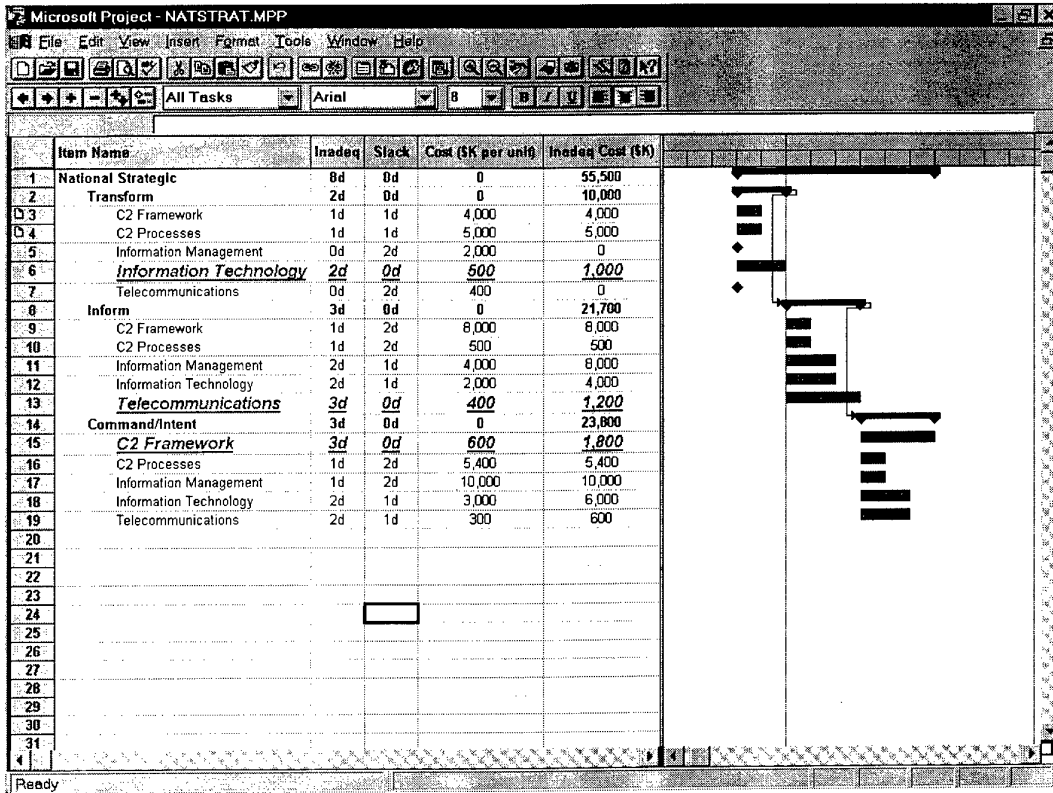

Figure 8: MS Project representation of C2 Support at National Strategic level

The View mode (see Appendix A) is that of a standard Gantt Chart. This environment consists of two main sections.

(i) Tabular section: located on the left and listing the model items plus associated:

- Individual or Critical Inadequacy values;
- Inadequacy 'slack';
- Unit cost; and
- Inadequacy Cost.

This format of the Tabular section results from use of a customised InadequacyCost table (see Appendix A). Notes can be placed against each entry in the table and enables, for example, a record to be made of the rationale behind the derivation of Inadequacy and associated cost figures.

(ii) Bar chart section: in the standard Gantt chart form. For each model item there is a corresponding bar indicating associated Inadequacy figures. Linkages

between model items are visualised; note that the C2S factors (Transform-
Inform-Command/Intent) are considered sequential.

4.1.2 Representing the C2S layers

Each C2S layer (C2F, C2P, IM, IT, T) is represented as a model item. Since there is no intrinsic sequence to these layers, the associated model items are considered concurrent and hence have no corresponding linkages.

4.1.2.1 *Inadequacy of each C2S layer*

Each C2S layer has associated values of Inadequacy between 0 and 3 that are entered by the user. C2S layers with an inadequacy of zero appear as project milestones in the Gantt chart but are treated in the same manner as other C2S layer items with non-zero inadequacy which appear as bars.

4.1.2.2 *Inadequacy Slack*

The Inadequacy Slack for each C2S layer is calculated and is an indication of how much the inadequacy of the layer can be increased before becoming critical (see later).

4.1.2.3 *Unit cost for each C2S layer.*

The cost per unit inadequacy is input by the user for each C2S layer. This is considered to be the cost of addressing a unit of inadequacy for a specific C2S layer. The assumption here is that a linear relationship holds; eg that addressing an inadequacy of 2 will cost twice as much as removing an inadequacy of 1.

4.1.2.4 *Inadequacy Cost of each C2S layer.*

The Inadequacy Cost for a C2S layer is calculated by a macro (see Appendix A) based on the associated values of inadequacy and unit cost. Figure 8 shows the complete allocation of cost rates and resultant inadequacy costs. The Inadequacy Cost is interpreted as the cost of addressing the total inadequacy of the C2S layer.

4.1.3 Representing the C2 Factors

Each of the Transform, Inform and Command/Intent factors are also represented as model items. The C2 factors are summary items that span across the five C2S layers within the factor and hence have no associated unit cost (a value of zero is shown). The Inadequacy value for a C2 factor corresponds to the maximum inadequacy of the C2S layers within, ie the Critical Inadequacy of that C2 factor. The Inadequacy Cost for a C2 factor is the total of the Inadequacy values for the C2S layers within; this is interpreted as the cost of addressing all inadequacy within the C2 factor.

The sequential transition from Transform to Inform to Command/Intent (shown in Figure 4) is represented by linkages between the C2 Factor model items. The linkages are visualised in the Gantt chart of Figure 8.

4.1.4 Total model costs and critical inadequacies

A model item corresponding to the overall model is used; in this case (Figure 8) it is labelled "National Strategic". This item is again a summary item which spans across the complete hierarchy of model work items. The Inadequacy value here is the total Critical Inadequacy and equals the total of inadequacies along the critical 'path'. The Inadequacy Slack will always be zero for total model items (except maybe in cases where the project is a sub-project, discussed later). The Inadequacy Cost of the total model is simply the total Inadequacy Cost; ie the total cost associated with removing all inadequacy.

4.1.5 Critical path analysis

Within a C2 Factor the notion of criticality applies to the C2S layer(s) with the greatest Inadequacy; ie that (those) that most hinder 'completion' of the C2 factor. Across the whole model the same notion applies. The critical C2S layers in the model are automatically (see Appendix A) identified by MS Project and have been set up such that the item name appears red, bolded, italicised, underlined and slightly larger than other item names. The Inadequacy Slack is zero for the critical C2S layers. For the example concerned the model shows that *"in a DOA scenario at the National Strategic level of command, the critical inadequacies in C2S are in Information Technology to support the Transform process, Telecommunications to support the Inform process, and C2 Framework to support Command and Intent"*. These critical layers are shown in Figure 8 and correspond to the inadequacy peaks in Figure 3.

Changing Inadequacy figures for C2S layers will automatically regenerate the new critical C2S layers. For example, changing the Inadequacy of Telecommunications in Inform to 1 will result in IM and IT within this C2 factor being critical layers.

Similarly removing the Inadequacy Slack associated with Transform's C2P layer, ie raising the inadequacy of that item from 1 to 2, will result in that item becoming critical and added to the set of critical layers. (In general a new critical item can completely change the set of critical layers.)

These examples are simplistic and the results are evident from looking at Figure 3; however, the power of the technique lies in its scalability which will be demonstrated later.

4.1.6 Cost analysis

A form of cost analysis might be the determination of key areas to inject funding in order to remedy particular inadequacies in C2S. The MS Project representation facilitates this through the use of Total Inadequacy (in this case shown for the National Strategic model item) as an overall metric. The software enables the trialling of certain funding injection.

For example, assume a proposal was made to inject \$4M to address the critical inadequacies identified in Figure 8. The model software enables the Inadequacy values of the three critical items to be set to zero and inspect the effect. The new critical areas of C2S would be automatically identified plus calculation of new Total Inadequacy and Inadequacy Cost. The result is shown in Figure 9.

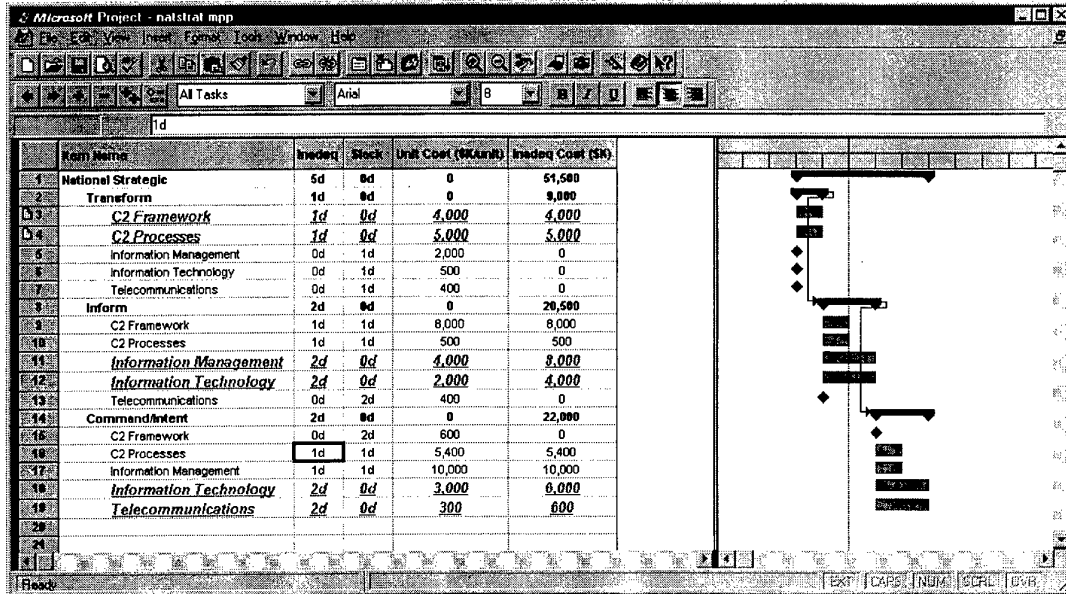

Figure 9: Revised model of C2 Support at National Strategic level

The new Total Inadequacy Cost is simply the previous total minus the funds injected. However, the new Total Inadequacy may not be so obvious in a complex and higher granularity model; the automation capability that is offered here can potentially be a significant analysis aid.

4.2 First cut representation of a full DOA scenario

In order to give an initial appreciation of the scalability of the modelling approach, a representation of the full DOA scenario conveyed in Figures 3 to 7 is given in Appendix B. The environment and capabilities are identical to those discussed in Section 4.1.

Figure 8 concerned the National Strategic level of command; the model detailed in Appendix B includes the remaining levels of command. Also incorporated is an item for the overall model, labelled "DOA". The critical path analysis identifies that *"in a DOA scenario, the critical inadequacies in C2S occur at the Military Strategic and Tactical levels of command"*. The specific critical C2S layers for associated C2 factors are also identified within the levels of command. The process of conducting inadequacy and cost analysis would be identical for this full DOA model as that conveyed for the National Strategic level of command in Section 4.1.

The MS Project file will rapidly become large for more detailed scenarios. There are numerous aids for managing this including the ability to collapse the project so that only summary items are displayed in regions specified by the user. An example of this flexibility is shown in Figure 10 for the single DOA model detailed in Appendix B. It should be noted, however, that critical summary items are not highlighted which is an impediment to visualising the characteristics of the overall project.

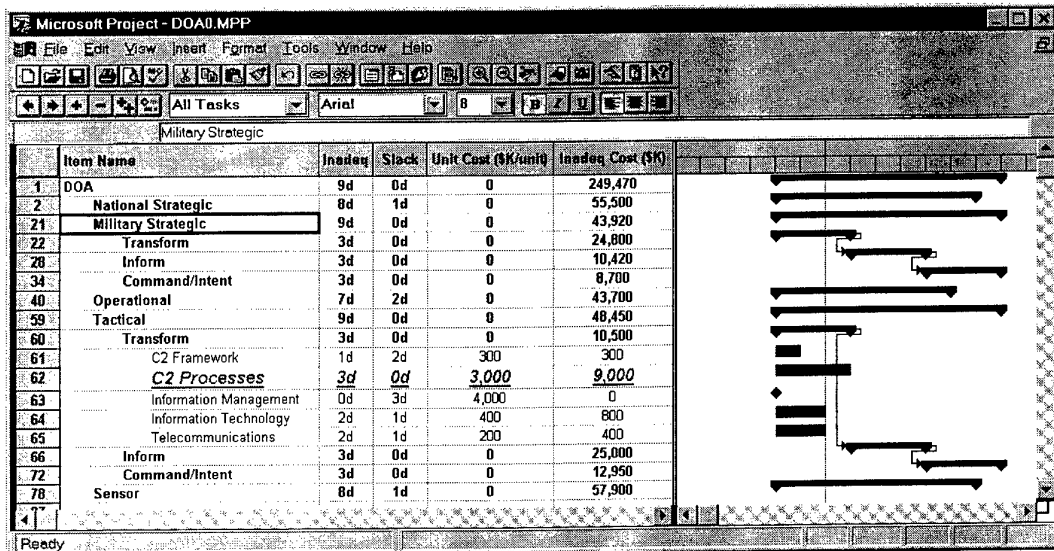

Figure 10: Collapsed model of C2 Support for DOA scenario

A hierarchical representation with some flexibility in visualisation is therefore achievable with a single model. A more modular approach can also be employed using sub-projects which avoids the data visualisation limitation exemplified above.

4.3 Modular representation of a full DOA scenario

The preceding sections serve to demonstrate the model implementation environment and the manner in which critical path and cost analysis can be employed in the study of C2S. A more flexible and modular approach would offer benefits and this has been aspired to through the use of sub-projects (see Appendix A) within MS Project. The basic analysis techniques conveyed in previous sections still hold. The user has complete flexibility as to what extent sub-projects are adopted; in this section sub-projects will be purposefully used extensively.

Any project, such as those presented earlier, can be referenced as a sub-project by another, higher-level, project. In such a case a model item within the higher-level project will assume the Inadequacy and other information of the sub-project. Critical path analysis can be applied to the resulting hierarchy.

4.3.1 Representing C2S primitives as sub-projects

In order to maximise ease of reuse there is a need to employ basic C2S primitives. Such primitives are implemented using sub-projects. The C2S primitives are considered to be the C2 factors and their layers of support. An MS Project representation of the National Strategic Inform factor is shown in Figure 11.

Item Name	Inadeq	Stack	Unit Cost (\$/unit)	Inadeq Cost (\$K)
1 C2S Layers	3d	0d	0	21,700
2 C2 Framework	1d	2d	8,000	8,000
3 C2 Processes	1d	2d	500	500
4 Information Management	2d	1d	4,000	8,000
5 Information Technology	2d	1d	2,000	4,000
6 Telecommunications	3d	0d	400	1,200
7				

Figure 11: Representation of National Strategic Inform factor

The C2 factor has a generic structure. The process of producing particular C2 factor models, such as that of Figure 11, involves copying the associated MS Project file, renaming and storing it in an appropriate directory if required, and tailoring it through revised inadequacy and unit cost values. This process involves minimal effort and was carried out in order to generate sub-projects for every C2 factor of each level of command of the DOA scenario.

4.3.2 Employing C2S primitives to form a hierarchical DOA model

Figure 12 shows the structure used to form an equivalent but more modular and flexible version of the DOA model presented in Section 4.2.

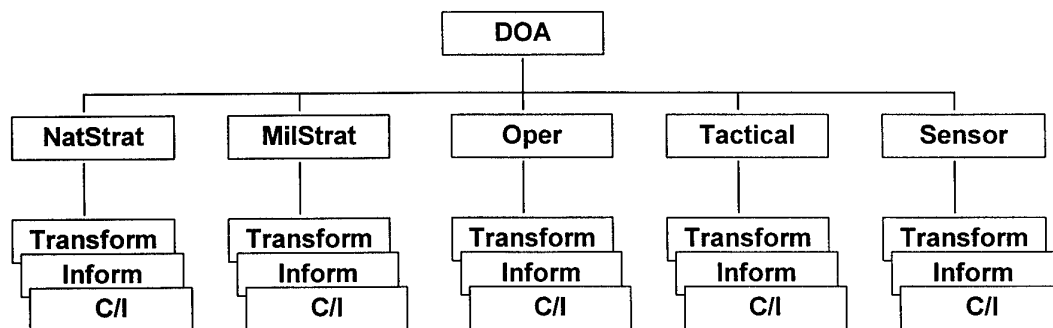

Figure 12: Hierarchical representation of sub-projects for DOA scenario

The top-level DOA project is shown in Figure 13 with model items corresponding to the levels of command for which exist sub-projects. At this level the critical levels of command are highlighted through critical path analysis of the whole model. This permits facts such as "in a DOA scenario, the critical inadequacies in C2S occur at the Military Strategic and Tactical levels of command" to be immediately ascertained. Such abstracted facts cannot necessarily easily be achieved in a monolithic MS Project model.

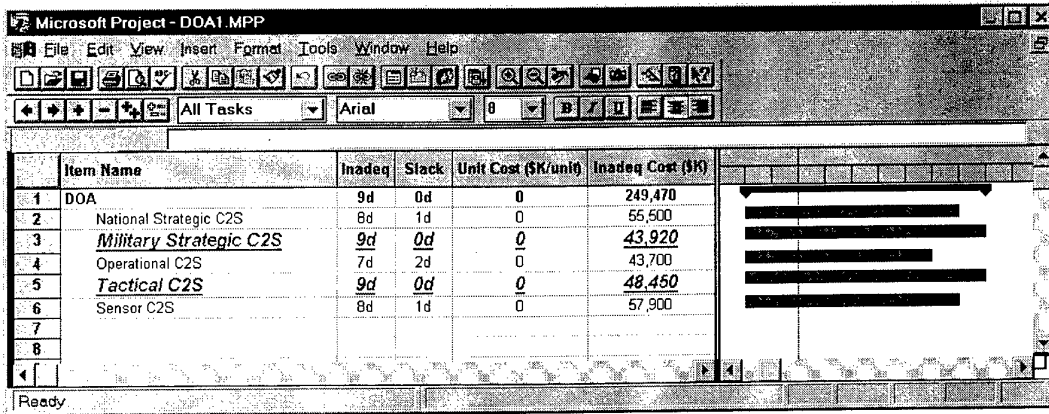

Figure 13: Top-level MS Project model of DOA scenario

Drilling through the critical Military Strategic item presents the sub-project shown in Figure 14. This shows each of the C2 factors contributing to the criticality of the Military Strategic level owing to their sequential nature. Thus "the criticality of the Military Strategic level results from critical inadequacies within each of the C2S layers" is determined.

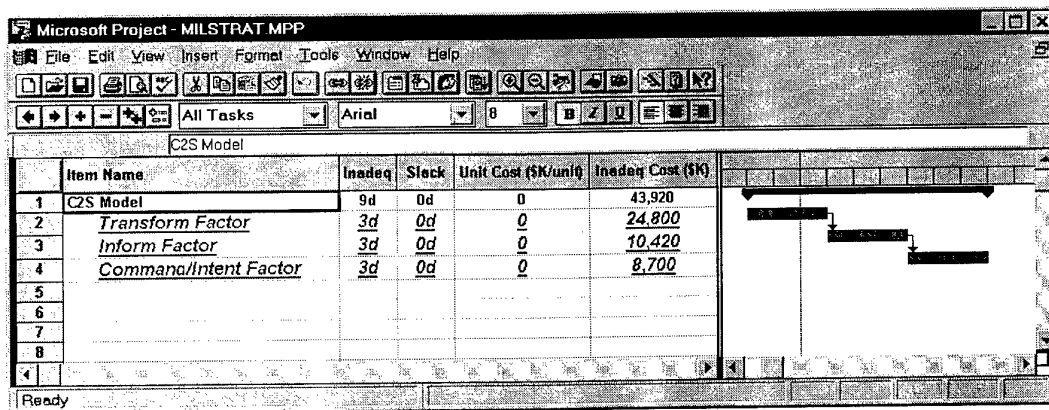

Figure 14: Military Strategic sub-project of DOA scenario

Drilling further through this hierarchy into the Transform layer presents the sub-project shown in Figure 15. This C2S primitive shows that "the critical inadequacies of the Transformation factor of C2S occur in the C2 Framework and Telecommunication layers".

Item ID	Item Name	Inadeq	Slack	Unit Cost (\$K/unit)	Inadeq Cost (\$K)
1	C2S Layers	3d	0d	0	24,800
2	C2 Framework	3d	0d	4,000	12,000
3	C2 Processes	2d	1d	5,000	10,000
4	Information Management	1d	2d	300	300
5	Information Technology	1d	2d	100	100
6	Telecommunications	3d	0d	800	2,400

Figure 15: Military Strategic Transform sub-project of DOA scenario

The same process can be conducted on other branches of the hierarchical model and exemplifies the layered analysis that this form of model permits. The above example concerned drilling down through critical items to further pinpoint sources of inadequacy. The example conveyed the use of the automatic critical path analysis capabilities of MS Project which are designed to look at the effect of a particular sub-project on the complete hierarchical model. MS Project also offers the ability to conduct critical path analysis on a sub-project in isolation. As an example consider drilling into the Transform factor of a non-critical branch such as the Operational level of Figure 13. This gives the model shown in Figure 16.

Item ID	Item Name	Inadeq	Slack	Unit Cost (\$K/unit)	Inadeq Cost (\$K)
1	C2S Layers	3d	2d	0	6,400
2	C2 Framework	1d	4d	800	800
3	C2 Processes	1d	4d	4,000	4,000
4	Information Management	0d	5d	1,000	0
5	Information Technology	3d	2d	500	1,500
6	Telecommunications	1d	4d	100	100

Figure 16: Operational Transform sub-project of DOA scenario

It should be noted that no critical C2S layers are highlighted and that all inadequacy slack figures are non-zero which reflect that this C2 Factor and its layers of support are non-critical in the overall DOA scenario. Instructing MS Project to compute the critical path for this project in isolation (see Appendix A) gives Figure 17 which correctly identifies the IT layer as being critical to the Transform factor of the Operational level of command. (Appendix C gives some shortcomings in this area.)

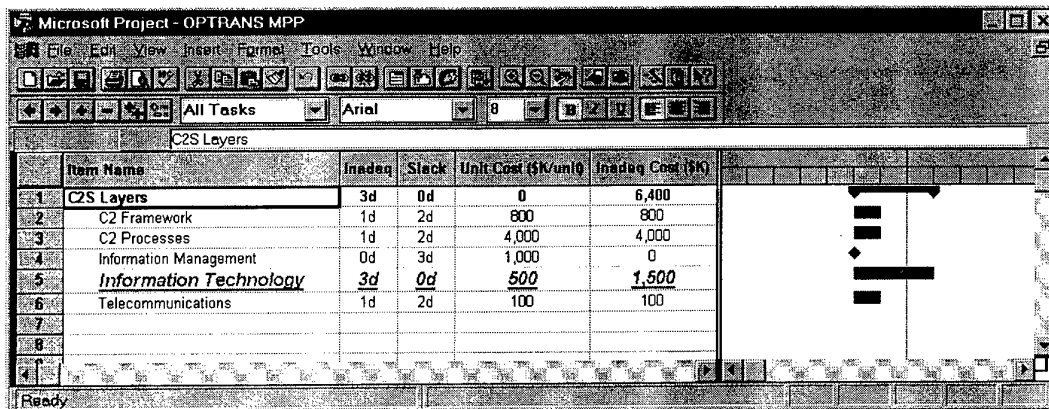

Figure 17: Local criticalities for Operational Transform sub-project of DOA scenario

5. Scalability: Supporting A More Detailed Analysis

Preceding sections of this document have concentrated on conveying how MS Project can be used to represent and analyse a DOA scenario that is equivalent to the models presented in Phase II of the C2SS[2]. The benefits of using this tool for critical path analysis become more apparent with growth in model complexity. This section will illustrate this by applying more detail to the C2SS DOA scenario. It should be noted that there are probably many options for addressing more detail and many ways of implementing an MS Project representation. The requirement for and manner of possible C2SS Phase II scenario extensions are yet to be determined. Earlier examples conveyed the use of two MS Project extremes: a monolithic project and the use of sub-projects for each C2S factor. This section uses the sub-project breakdown shown in Figure 18 to illustrate model design flexibility within the two extremes used earlier.

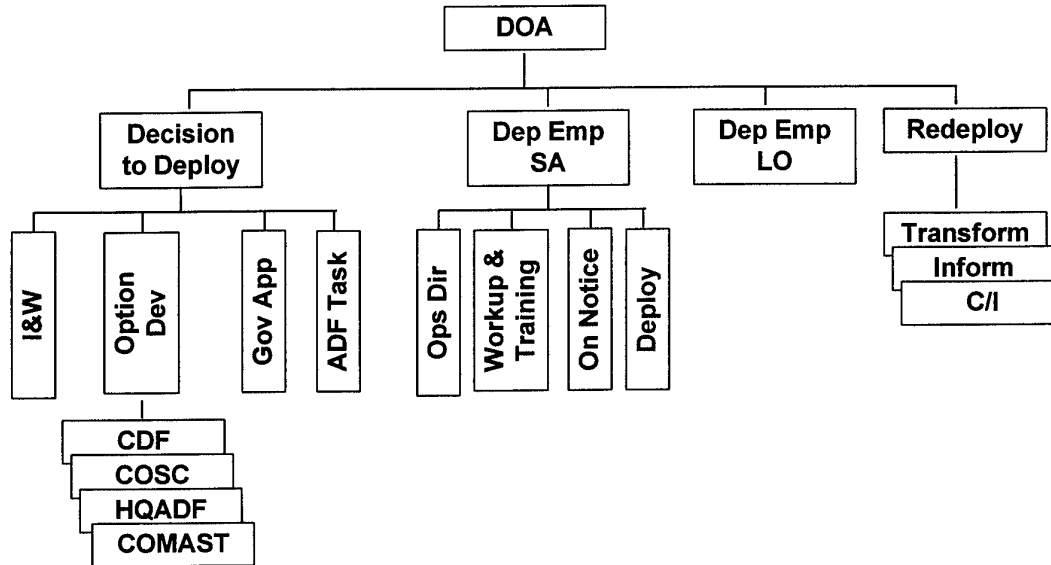

Figure 18: Hierarchical representation of sub-projects for detailed DOA scenario analysis

5.1 Breaking up the scenario into phases

Rather than use levels of command (Figure 12) to modularise the DOA scenario, the scenario is here broken up into the phases identified in reference 2. In order, these phases are:

- Decision to deploy;
- Deployment and employment in the sea-air gap;
- Deployment and employment in the Land area of operations and redeployment planning; and
- Redeployment.

The top-level DOA project is hence that shown in Figure 19 where each phase has a corresponding sub-project. At this level (for the invented data used) "the critical inadequacy in C2S occurs during the Decision To Deploy phase".

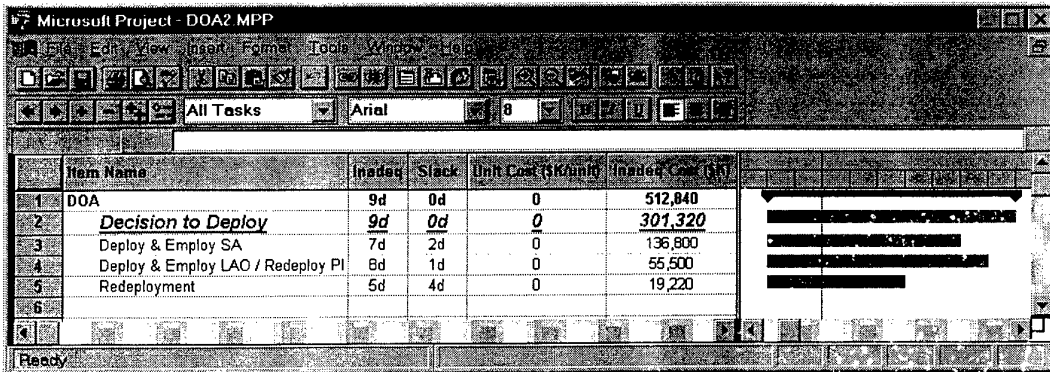

Figure 19: Top-level MS Project model of DOA scenario

5.2 Representing phases of operation

Representation of each phase in this example demonstrates the variable depth of detail that can be accommodated. As shown in Figure 18 the Decision to Deploy phase is represented in most detail; Figure 20 shows the project representation consisting of 4 sub-projects corresponding to the Indicators and Warnings (I&W), option development, government appreciation and ADF tasking stages. At this level "the Decision to Deploy phase is critical owing to inadequacies in the Option Development stage" can be determined.

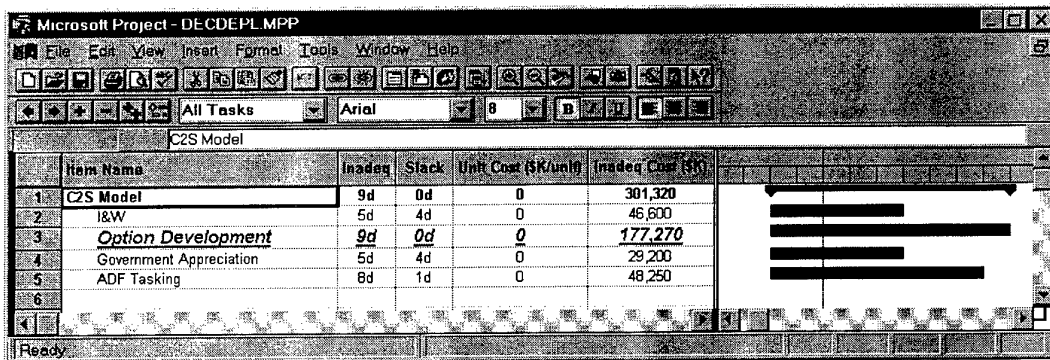

Figure 20: The decision to deploy phase of the DOA scenario

The sub-project for the I&W stage is shown in Figure 21; as shown in Figure 18 this is the lowest level for this branch of the DOA tree structure. Hence the C2S primitive in this case is a representation of all three C2S factors as used in the initial model of Figure 8. No items are highlighted as critical since the I&W stage is not critical to the overall DOA scenario; again, manual calculation options are

available to inspect criticalities local to the I&W stage. The Government Appreciation and ADF Tasking stages are represented in an identical manner.

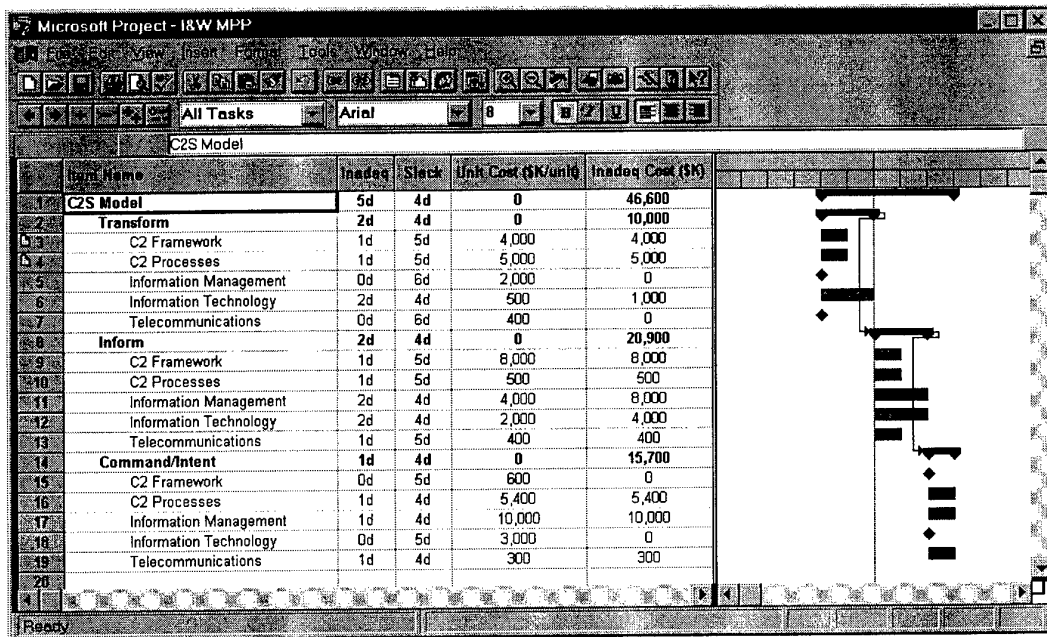

Figure 21: The I&W stage of the DOA scenario

Whilst C2S for the I&W stage is summarised through the use of factors at that level, the Option Development stage is represented in further detail by consideration of each of the key ADF agencies involved (Figure 18). The sub-project for this stage is shown in Figure 22 which has sub-projects for each of the ADF agencies concerned. At this level it can be determined that "the Options Development stage is critical owing to inadequate C2S of the contributions of CDF and COMAST".

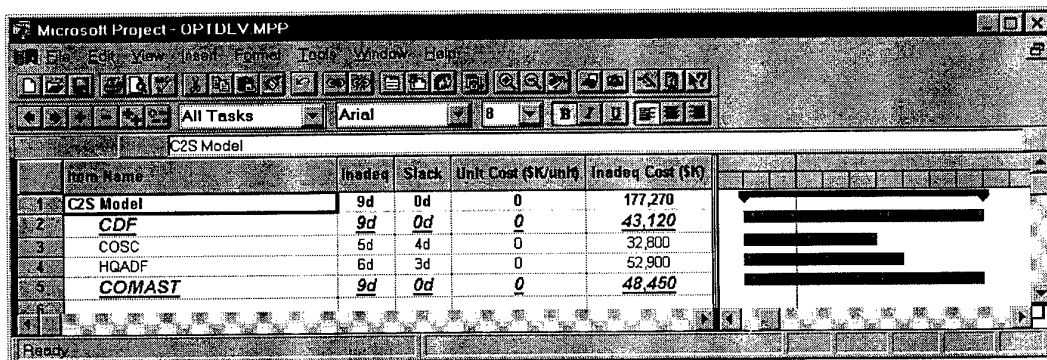

Figure 22: The Option Development stage of the DOA scenario

The degree of C2S for each of the agencies shown in Figure 22 is represented in the manner shown in Figure 21.

The use of sub-projects for the remaining branches of the DOA hierarchy is as shown in Figure 18. The Redeployment phase is represented through the use of separate sub-projects for each of the C2 factors as presented in Section 4.3.2.

6. Summary and Discussion of Capabilities

The use of Petri nets (PN) and project management tools have been investigated for providing a critical path capability to the analysis of C2S inadequacy identified in the C2SS. The use of PN generates linkages to other analysis capabilities such as simulation and access to explanation and analysis tools[3]. Critical path analysis, however, is a secondary or spin-off capability of PN and hence for the PN tools considered is not supported by a user friendly environment. Also, additional PN attributes plus associated functions would need to be introduced in order to conduct cost analysis. Critical path and cost analysis are typically intrinsic features within commercial project management tools. Use of such a tool is therefore preferred and MS Project was chosen for this investigation owing to its availability and user familiarity.

Use of MS Project provides an ability to:

- Construct a hierarchical representation of an ADF scenario or structure with associated C2S inadequacy values and cost.
- Employ a flexible model design through the use of sub-projects and C2S primitives.
- Automatically generate and visualise critical areas of C2S inadequacy at various levels of abstraction in the model hierarchy.
- Vary inadequacy values and cost for the purposes of cost-benefit and other analysis.

A quantitative analysis technique has been applied to qualitative data. The assumption was made that two values of inadequacy can be quantitatively compared.

There are a number of identified shortcomings associated with the use of MS Project and critical path analysis to C2S. Some of the weaknesses may be addressed through the use of macros; this has not been fully investigated to date.

- Sub-projects require separate MS Project files, each with associated overheads in size.
- The critical path algorithm when applied to individual sub-projects has some limiting but manageable anomalies (see Appendix C);

- Apart from guaranteed common C2S primitives such as the C2S factors, no arrangement of model items in sequence is permitted (see Appendix C).
- Adequacy relates to Duration for which the most convenient unit was days. However, no means of removing the 'd' from Inadequacy entries could be found.
- Drilling down and working up a particular branch of a model hierarchy can be achieved with ease in MS Project through successive opening and closing of files. In general traversing the hierarchy laterally creates confusion regarding location in a complex model. The PERT Chart view was investigated but is regarded as requiring too much manual adjustment to make it user friendly and does not offer any additional features over the Gantt Chart view.
- Use of the macro to compute inadequacy cost is completely manual; no mechanism for automating this could be found.

The nature of further analysis within the C2SS is yet to be clarified. One example of how more detail could be introduced is:

- Rather than using levels of command, break down a scenario into the various operational phases and stages therein;
- Introduce the specific agencies associated with a scenario for which C2S is required (a level of command view could maybe be introduced here if really needed);
- Introduce specific systems such as CSS and telecommunications associated with the provision of C2S.

If a stochastic presence arises (eg assigning inadequacy values with some degree of uncertainty) then a PERT technique (or simulation equivalent[4]) or Petri net simulation may then become more appropriate. Petri nets also offer the flexibility of designing a single C2S model that enables both time-based and other (eg inadequacy-based) analysis to be conducted simultaneously.

The analysis capability offered in this report would be greater and more evident if a larger range of values (compared with 0, 1, 2 and 3) for inadequacy were used in the C2SS. The inadequacy cost functions used assume a linear relationship between cost and inadequacy. A more complex function could be employed through the use of macros.

7. Conclusions

An ability to apply critical path analysis to the study of C2 Support has been demonstrated. The use of MS Project as a candidate tool for such analysis has been conveyed through the use of a Defence Of Australia scenario. Scenario data

indicative of that resulting from the current C2 Support Study has been used to illustrate the benefits in data management, reporting and analysis of applying this capability.

This report is the result of an initial effort to identify opportunities for supporting the C2SS, or some post-study activity, with more quantitative analysis using modelling and simulation.

8. Acknowledgement

The author would like to thank Ms Moira Chin of the C2SS for her contributions to this work.

9. References

1. "Command and Control Support Study Phase I Report", Issue 1.0, Working Group Report, RESTRICTED, July 1996
2. Clothier,J., Chin,M., Cathigaser,M., Culloden,I.,"Command and Control Support Study Phase 2 Report", Part 1, SECRET AUSTEO, November 1997
3. Davies,M., Bowden,F.D.J., Dunn,J.M., "An Explanation and Analysis Capability for Extended Petri Nets", DSTO Technical Report, DSTO-TR-0461, December 1996
4. Badiru,A.B., "A Simulation Approach to PERT Network Analysis", *Simulation*, October 1991, pp245-255

Appendix A - Key MS Project Utilities

This appendix will describe only those MS Project utilities whose employment is mentioned in the main text. It is not intended to provide a detailed user guide but rather pointers from the main menu and other locations to appropriate areas in the commercial product.

A1 Environment

A1.1 View

A View of Gantt Chart should be assumed unless stated otherwise.

Main Menu: View -> Gantt Chart

A1.2 Table

The custom designed InadequacyCost should be assumed unless stated otherwise.

Main Menu: View -> Table -> InadequacyCost

A2 Critical path generation

The manner in which the critical path is generated is achieved via the Calculation facility.

Main Menu: Tools -> Options -> Calculation

Automatic calculation should be chosen.

The "Calculate All Projects" option will show the current sub-project's critical path based on the relation of that sub-project to any predecessor item or sub-project(s) within the model hierarchy. That is, a one step look-back. This is the default setting if Automatic calculation is set. (See Appendix C for further information regarding this capability.)

The "Calculate Project" button will show the current sub-project's critical path based on the characteristics of that sub-project alone.

A3 Sub-project creation

An existing project can be linked into another project as a sub-project:

- Create a model item in the higher-level project that will correspond to the sub-project.

- Create link to sub-project:

Main Menu: Insert -> Task Information -> Advanced -> Sub-Project
(Browse)

A4 Inadequacy cost macro

The CalcInadeqCost macro can be activated using the:

<ctrl>T

hot key or via the following main menu facilities:

Main Menu: Tools -> Run CalcIneqCost

Main Menu: Tools -> Macros

Appendix B - Single Project Representation of DOA Scenario

The single project representation of the DOA scenario described by Figures 3 to 7 is shown in Figure B1 ((a) to (d)). The model is discussed in Section 4.2.

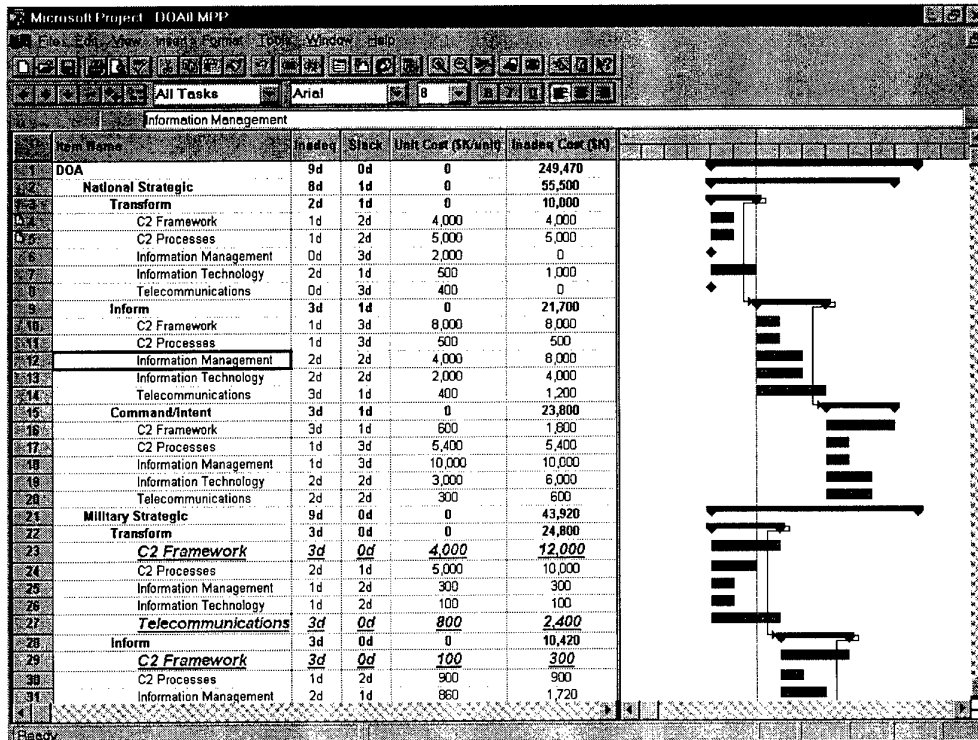

Figure B1(a): MS Project representation of C2 Support for DOA scenario

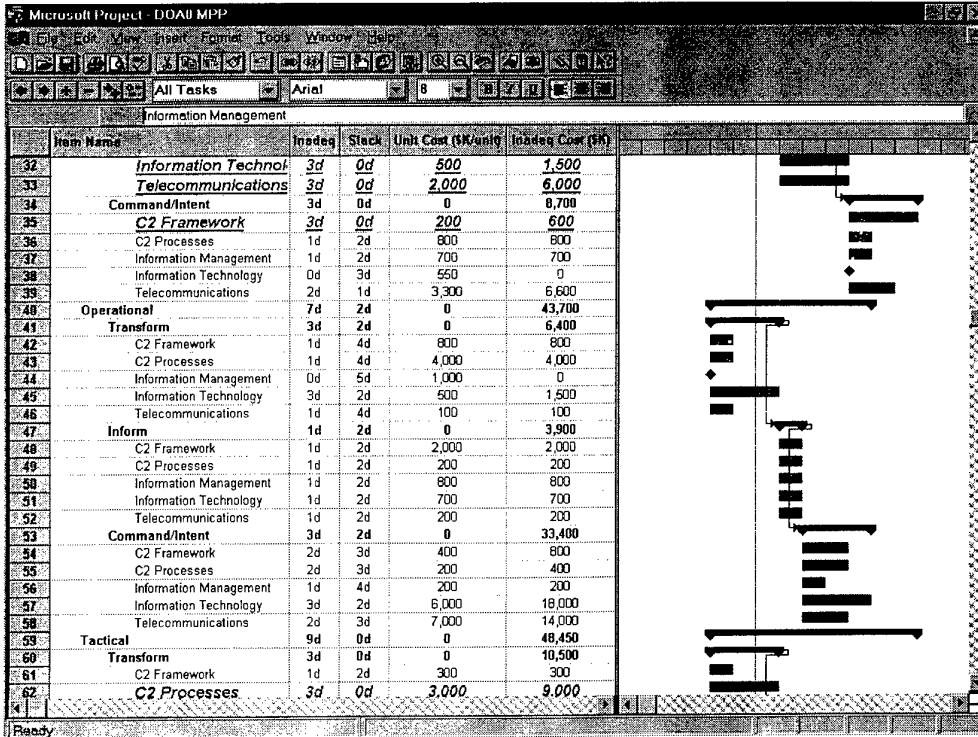

Figure B1(b): MS Project representation of C2 Support for DOA scenario

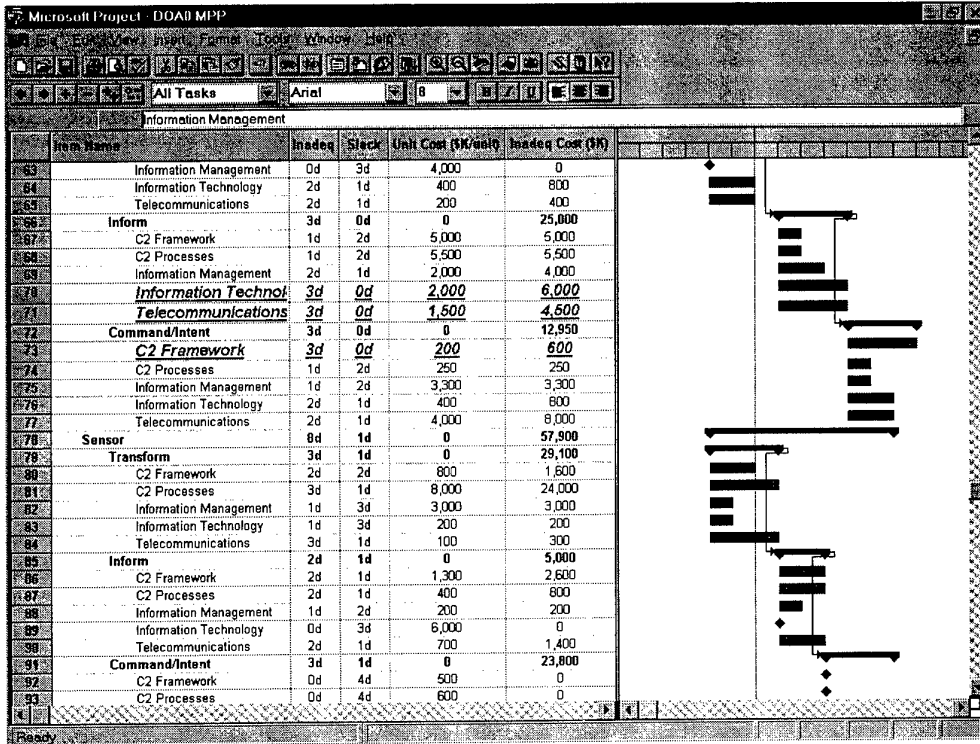

Figure B1(c): MS Project representation of C2 Support for DOA scenario

The screenshot shows the Microsoft Project interface with a task list. The title bar reads 'Microsoft Project - DOAIL.MPP'. The menu bar includes 'File', 'Edit', 'View', 'Insert', 'Format', 'Tools', 'Window', and 'Help'. The toolbar contains various icons for project management. The task list is displayed in a grid with the following columns: 'Item Name', 'Inades', 'Stack', 'Unit Cost (\$/unit)', and 'Inadeq Cost (\$)'.

Item Name	Inades	Stack	Unit Cost (\$/unit)	Inadeq Cost (\$)
94 Information Management	1d	3d	3,000	3,000
95 Information Technology	3d	1d	4,000	12,000
96 Telecommunications	2d	2d	4,400	8,800
97				
98				
99				
100				
101				
102				
103				
104				
105				
106				
107				
108				
109				
110				
111				
112				
113				
114				
115				
116				
117				
118				
119				
120				
121				
122				
123				
124				

Figure B1(d): MS Project representation of C2 Support for DOA scenario

Appendix C - Shortcomings In MS Project Critical Path Analysis

C1 Critical path generation in hierarchical projects

There are apparent shortcomings in MS Project regarding the built-in critical path analysis capabilities for hierarchical projects. Whether activated automatically or manually, for any project or sub-project there are two modes of application for critical path analysis (see Appendix A for user instructions).

- The "Calculate Project" button will show the current sub-project's critical path based on the characteristics of that sub-project alone.
- The "Calculate All Projects" option (the default automatic option) will show the current sub-project's critical path based on the relation of that sub-project to any predecessor item or sub-project(s) within the model hierarchy. That is, a one step look-back. This appears contrary to the description of the capability which implies an ability to show what items in the current sub-project are part of the critical 'path' of the complete project. An example of the consequences of this apparent deficiency when drilling down the hierarchy from a non-critical top-level model item follows.

The sub-project for the National Strategic (a non-critical level as shown in Figure 13) level is shown in Figure C1. No items are critical which is expected since the top-level item is non-critical also.

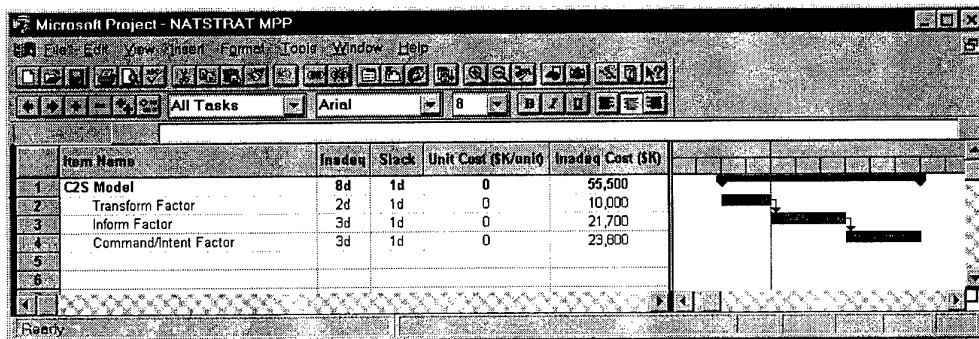

Item Name	Inadeq	Slack	Unit Cost (\$/unit)	Inadeq Cost (\$)
1 C2S Model	8d	1d	0	55,500
2 Transform Factor	2d	1d	0	10,000
3 Inform Factor	3d	1d	0	21,700
4 Command/Intent Factor	3d	1d	0	23,800
5				
6				

Figure C1: National Strategic level sub-project for DOA scenario

Drilling down further into the Transform C2 factor of this stream gives the sub-project shown in Figure C2. Again no items are critical as expected.

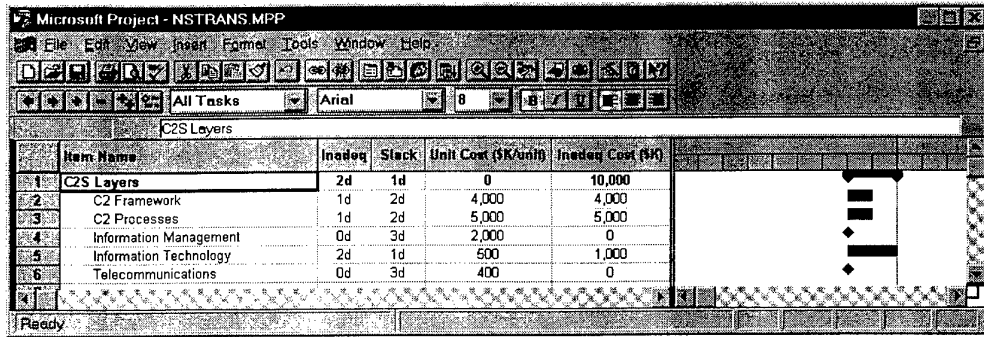

Figure C2: National Strategic level Transform factor for DOA scenario

Returning to the National Strategic level of Figure C1 but this time drilling down into the Inform stream gives the sub-project of Figure C3. The Telecommunications layer is highlighted as critical. This item is evidently not critical to the overall DOA scenario but has been highlighted because it has a predecessor, namely the National Strategic Transform sub-project of Figure C2. Each of the other example sub-projects shown in this appendix have no predecessors.

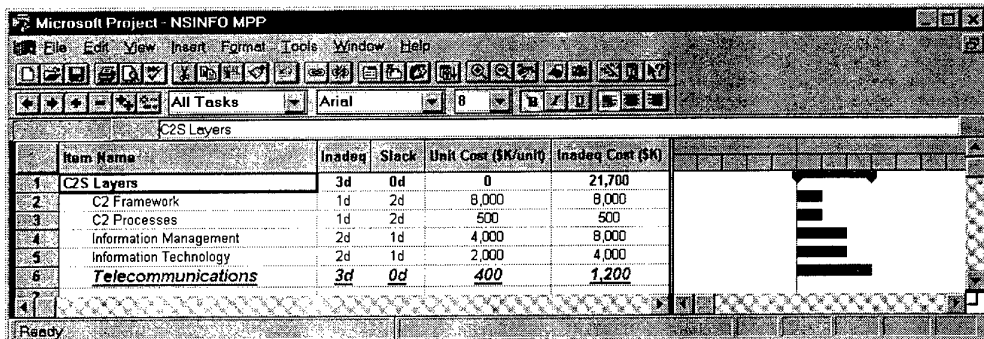

Figure C3: National Strategic level Inform factor for DOA scenario

The "predecessor problem" would appear to be a limitation in the algorithm and maybe even a software 'bug'. Item 3 in Figure C1 shows an Inadequacy value of 3 and an associated slack of 1 which is correct in that addressing that slack by raising the Inadequacy to 4 would make the Inform factor critical within the complete project. Item 1 in Figure C3, however, shows a correct Inadequacy of 3 but a slack of zero. This would seem to imply that the sub-project has a local focus or at most a one step look-back only and not a project wide focus.

The identified shortcomings are not considered prohibitive to the study of C2S and can be managed if the following rules of use and interpretation are

employed. The shortcomings can be completely avoided if sequences of model items are not permitted (see Section C2).

- If a top-level project item is critical then the answer to the question "Why" can be addressed through drilling down through the corresponding hierarchy of sub-projects (see earlier example). Lower-level critical items will be identified.
- If a top-level project item is non-critical then drilling through the corresponding hierarchy of sub-projects will not show non-criticality throughout. Any items shown as critical should be interpreted as being only critical locally and not throughout the entire project.
- The interpretation of any changes in criticality that might occur due to experimentation on lower-level project data should always be determined through top-down verification.

C2 Issues concerning variable depth

The detailed DOA model used in Section 5 is an example model with varying depth of detail (eg the Decision to Deploy branch compared with the Deployment & Employment in Land Area of Operations branch). It would be useful to organise phases and stages in the sequence that they occur in the scenario. For example, I&W followed by Option Development then Government Approval then ADF Tasking. The inadequacy of each phase would be the total of the stages within, and the inadequacy at the DOA level the total of the phases. This results in an imbalance.

Preserving the order of the DOA phases and stages would result in the Decision to Deploy node having a maximum inadequacy value of 36 compared with that of 9 for the 'Dep Emp LO' node. This would give misleading results when trying to identify inadequacy 'hot spots'.

The only items that are arranged in sequence in the DOA model of Section 5 then are the C2 factors. This is possible since the C2 factors are common primitives and all C2S models have the three factors in sequence. The inadequacy value of any node in the model tree structure will always be at most 9.

Forcing concurrent model items generally helps the application of critical path analysis. All sequential items along a critical path are critical even though some items may have a far lesser inadequacy than others. Forcing concurrent items means that those with the highest inadequacy can be identified within what would otherwise be an order to items, resulting in greater granularity to the analysis capability. (It should be noted that representing the C2S factors as concurrent factors has the same benefit and also circumvents the MS Project limitations discussed in Section C1. However, the sensitivity of the model is then reduced owing to all nodes now having a maximum inadequacy of 3 rather than 9.)

Critical Path Analysis of Command and Control Support

Mike Davies

(DSTO-TR-0678)

DISTRIBUTION LIST

Number of Copies

AUSTRALIA

DEFENCE ORGANISATION

Task sponsor:

Director General C3I Development (Attention: Director Operational Information Systems Development)	1
---	---

S&T Program

Chief Defence Scientist)	
FAS Science Policy)	1 shared copy
AS Science Corporate Management)	
Director General Science Policy Development	1
Counsellor, Defence Science, London	Doc Control Sheet
Counsellor, Defence Science, Washington	Doc Control Sheet
Scientific Adviser to MRDC Thailand	Doc Control Sheet
Director General Scientific Advisers and Trials)	1 shared copy
Scientific Adviser - Policy and Command)	
Navy Scientific Adviser	1 copy of Doc Control Sheet and 1 distribution list
Scientific Adviser - Army	Doc Control Sheet and 1 distribution list
Air Force Scientific Adviser	1
Director Trials	1

Aeronautical & Maritime Research Laboratory

Director	1
----------	---

Electronics and Surveillance Research Laboratory

Director	1
Chief Information Technology Division	1
Research Leader Command & Control and Intelligence Systems	1
Research Leader Military Computing Systems	1
Research Leader Command, Control and Communications	1
Executive Officer, Information Technology Division	Doc Control Sheet
Head, Information Architectures Group	1
Head, Information Warfare Studies Group	Doc Control Sheet
Head, Software Systems Engineering Group	Doc Control Sheet
Head, Year 2000 Project	Doc Control Sheet
Head, Trusted Computer Systems Group	Doc Control Sheet
Head, Advanced Computer Capabilities Group	Doc Control Sheet
Head, Systems Simulation and Assessment Group	1

Head, Intelligence Systems Group	Doc Control Sheet
Head, CCIS Interoperability Lab	Doc Control Sheet
Head Command Support Systems Group	1
Head, C3I Operational Analysis Group	Doc Control Sheet
Head Information Management and Fusion Group	1
Head, Human Systems Integration Group	Doc Control Sheet
Head, C2 Australian Theatre	1
Author	1
Publications and Publicity Officer, ITD	1
DSTO Library and Archives	
Library Fishermens Bend	1
Library Maribyrnong	1
Library Salisbury	2
Australian Archives	1
Library, MOD, Pyrmont	Doc Control Sheet
Capability Development Division	
Director General Maritime Development	Doc Control Sheet
Director General Land Development	Doc Control Sheet
Director General C3I Development	Doc Control Sheet
Navy	
SO (Science), Director of Naval Warfare, Maritime Headquarters Annex, Garden Island, NSW 2000	Doc Control Sheet
Army	
ABCA Office, G-1-34, Russell Offices, Canberra	4
SO (Science), DJFHQ(L), MILPO, Enoggera, Qld 4051	Doc Control Sheet
NAPOC QWG Engineer NBCD c/- DENGSR-A, HQ Engineer Centre Liverpool Military Area, NSW 2174	Doc Control Sheet
Intelligence Program	
DGSTA Defence Intelligence Organisation	1
Corporate Support Program (libraries)	
OIC TRS Defence Regional Library, Canberra	1
Officer in Charge, Document Exchange Centre (DEC),	Doc Control Sheet & Distribution List
US Defence Technical Information Center,	2
UK Defence Research Information Centre,	2
Canada Defence Scientific Information Service,	1
NZ Defence Information Centre,	1
National Library of Australia,	1
Universities and Colleges	
Australian Defence Force Academy	1
Library	1
Head of Aerospace and Mechanical Engineering	1
Deakin University, Serials Section (M list)), Deakin University Library, Geelong, 3217	
Senior Librarian, Hargrave Library, Monash University	1
Librarian, Flinders University	1

Other Organisations

NASA (Canberra)	1
AGPS	1
State Library of South Australia	1
Parliamentary Library, South Australia	1

OUTSIDE AUSTRALIA**Abstracting and Information Organisations**

INSPEC: Acquisitions Section Institution of Electrical Engineers	1
Library, Chemical Abstracts Reference Service	1
Engineering Societies Library, US	1
Materials Information, Cambridge Scientific Abstracts	1
Documents Librarian, The Center for Research Libraries, US	1

Information Exchange Agreement Partners

Acquisitions Unit, Science Reference and Information Service, UK	1
Library - Exchange Desk, National Institute of Standards and Technology, US	1

Henry A. Neimeier, Principal Engineer, Economic and Decision Analysis Center,
The MITRE Corporation/Washington C3 Center, 1820 Dolly Madison Blvd,
McLean, Virginia, US 22102-3481

1

SPARES

10

Total number of copies:**66**

DEFENCE SCIENCE AND TECHNOLOGY ORGANISATION DOCUMENT CONTROL DATA		1. PRIVACY MARKING/CAVEAT (OF DOCUMENT)			
		2. TITLE Critical Path Analysis of Command and Control Support		3. SECURITY CLASSIFICATION (FOR UNCLASSIFIED REPORTS THAT ARE LIMITED RELEASE USE (L) NEXT TO DOCUMENT CLASSIFICATION) Document (U) Title (U) Abstract (U)	
4. AUTHOR(S) Mike Davies		5. CORPORATE AUTHOR Electronics and Surveillance Research Laboratory PO Box 1500 Salisbury SA 5108			
6a. DSTO NUMBER DSTO-TR-0678	6b. AR NUMBER AR-010-559	6c. TYPE OF REPORT Technical Report	7. DOCUMENT DATE June 1998		
8. FILE NUMBER N9505/15/87	9. TASK NUMBER ADF 96/210	10. TASK SPONSOR DGC3ID	11. NO. OF PAGES 48	12. NO. OF REFERENCES 4	
13. DOWNGRADING/DELIMITING INSTRUCTIONS N/A		14. RELEASE AUTHORITY Chief, Information Technology Division			
15. SECONDARY RELEASE STATEMENT OF THIS DOCUMENT <i>Approved for public release</i>					
OVERSEAS ENQUIRIES OUTSIDE STATED LIMITATIONS SHOULD BE REFERRED THROUGH DOCUMENT EXCHANGE CENTRE, DIS NETWORK OFFICE, DEPT OF DEFENCE, CAMPBELL PARK OFFICES, CANBERRA ACT 2600					
16. DELIBERATE ANNOUNCEMENT No limitations					
17. CASUAL ANNOUNCEMENT Yes					
18. DEFTEST DESCRIPTORS Command and control Command and control systems Critical path method Defense systems Australian Defence Force					
19. ABSTRACT The Command and Control (C2) Support Study (C2SS) was established to assess the strengths and weaknesses of ADF C2 support and analyse options for addressing the identified weaknesses. Scope for employing critical path analysis capabilities to assist the C2SS in data management, reporting and analysis has been determined. This document conveys the capabilities and associated opportunities through the use of a collection of unclassified examples based on invented data for a Defence Of Australia scenario used in the C2SS.					