

180159

JPRS-CST-84-014

11 May 1984

19981112 117

China Report

SCIENCE AND TECHNOLOGY

DTIC QUALITY INSURED &

FBIS

FOREIGN BROADCAST INFORMATION SERVICE

REPRODUCED BY
NATIONAL TECHNICAL
INFORMATION SERVICE
U.S. DEPARTMENT OF COMMERCE
SPRINGFIELD, VA. 22161

17
48
A03

NOTE

JPRS publications contain information primarily from foreign newspapers, periodicals and books, but also from news agency transmissions and broadcasts. Materials from foreign-language sources are translated; those from English-language sources are transcribed or reprinted, with the original phrasing and other characteristics retained.

Headlines, editorial reports, and material enclosed in brackets [] are supplied by JPRS. Processing indicators such as [Text] or [Excerpt] in the first line of each item, or following the last line of a brief, indicate how the original information was processed. Where no processing indicator is given, the information was summarized or extracted.

Unfamiliar names rendered phonetically or transliterated are enclosed in parentheses. Words or names preceded by a question mark and enclosed in parentheses were not clear in the original but have been supplied as appropriate in context. Other unattributed parenthetical notes within the body of an item originate with the source. Times within items are as given by source.

The contents of this publication in no way represent the policies, views or attitudes of the U.S. Government.

PROCUREMENT OF PUBLICATIONS

JPRS publications may be ordered from the National Technical Information Service, Springfield, Virginia 22161. In ordering, it is recommended that the JPRS number, title, date and author, if applicable, of publication be cited.

Current JPRS publications are announced in Government Reports Announcements issued semi-monthly by the National Technical Information Service, and are listed in the Monthly Catalog of U.S. Government Publications issued by the Superintendent of Documents, U.S. Government Printing Office, Washington, D.C. 20402.

Correspondence pertaining to matters other than procurement may be addressed to Joint Publications Research Service, 1000 North Glebe Road, Arlington, Virginia 22201.

11 May 1984

CHINA REPORT

SCIENCE AND TECHNOLOGY

CONTENTS

PEOPLE'S REPUBLIC OF CHINA

NATIONAL DEVELOPMENTS

Science Academy Meeting on Exploiting Xinjiang (Xinjiang Regional Service, 8 Apr 84)	1
Intellectuals Contribute to Modernization Drive (XINHUA, 12 Apr 84)	3

APPLIED SCIENCES

State S&T Commission Approves Inventions (RENMIN RIBAO, 21 Dec 83)	5
Optimization Design of Earth Orbit Reentry Vehicle Configurations for Minimum Aerodynamic Heat Transfer (Zhou Qicheng, Wang Zhonglian; KONGQI DONGGLIXUE, No 3, 1983)	20

LIFE SCIENCES

Health Minister Writes Jiankang Bao Article (XINHUA, 5 Apr 84)	33
---	----

SCIENTISTS AND SCIENTIFIC ORGANIZATIONS

Rocket Designer's Contributions To Space Program Described (Yan Zhiping, et al.; GUANGMING RIBAO, 8 Mar 84)	34
--	----

ABSTRACTS

COMMUNICATIONS

TONGXIN XUEBAO [JOURNAL OF CHINA INSTITUTE OF COMMUNICATIONS] No 1, 1984	41
---	----

RADIOLOGY

ZHONGHUA FANGSHE YIXUE YU FANGHU ZAZHI [CHINESE JOURNAL OF
RADIOLOGICAL MEDICINE AND PROTECTION] No 6, 25 Dec 83

44

NATIONAL DEVELOPMENTS

SCIENCE ACADEMY MEETING ON EXPLOITING XINJIANG

HK101332 Urumqi Xinjiang Regional Service in Mandarin 1300 GMT 8 Apr 84

[Excerpts] The meeting of the Chinese Academy of Sciences on developing scientific research in Xinjiang was held in the Urumqi Kunlun guesthouse this afternoon. This meeting was a mobilization meeting of the Chinese Academy of Sciences on exploiting Xinjiang and conducting large-scale scientific investigation and research.

Some 200 experts, professors, and scientific research workers from Beijing, Shanghai, Nanjing, Lanzhou, Wuhan, Shenyang, Guiyang, Changsha, Changchun, and Xi'an and from all relevant scientific research units, universities, colleges, and production departments in Xinjiang attended the meeting. Some 60 of them are scientific research personnel at and above the levels of associate research fellow and associate professor.

Ye Duzheng, vice president of the Chinese Academy of Sciences, spoke at the meeting. He said: Exploiting and building Xinjiang is an exploitative work and a long-term task. In close connection with the realities of industrial and agricultural production, we must carry forward the great socialist cooperative spirit, unite as one, make concerted efforts, and make new contributions toward the exploitation and building of Xinjiang.

On behalf of the regional CPC committee, Janabil, secretary of the regional CPC committee, extended warm greetings and welcome to the meeting and gave cordial regards to the experts, professors, and scientific and technological workers who came from afar and to all representatives present at the meeting. Janabil said: To exploit and build Xinjiang, we need science and technology. We warmly welcome experts, professors, and middle-aged and young scientific and technological personnel in specific fields from the coastal areas and the hinterland to Xinjiang to help with exploitative and building work. We welcome them to settle down in Xinjiang. We warmly welcome departments concerned to organize more scientific and technological personnel to come to the region.

Janabil demanded that departments concerned in the region must vigorously support the Chinese Academy of Sciences to unfold work in Xinjiang. They must vigorously cooperate with the academy. He hoped that scientific and technological workers of all nationalities in the region will strengthen unity

and closely coordinate with the scientific and technological personnel of the Chinese Academy of Sciences under the great objective of exploiting Xinjiang, and that they will work effectively and will make new contributions.

Sun Honglie, vice president of the Chinese Academy of Sciences; and responsible comrades of the regional party and government, including Tomur Dawamat, Tan Shanhe, Zhang Sixue, Song Hanliang, and Liu Zimo, attended today's meeting. Yang Yuming, chairman of the regional science and technology committee, spoke at the meeting. (Yan Zhining), vice chairman of the committee for comprehensive survey of natural resources of the Chinese Academy of Sciences, introduced at the meeting the projects and subjects of scientific research in the exploitation of Xinjiang.

CSO: 4008/251

NATIONAL DEVELOPMENTS

INTELLECTUALS CONTRIBUTE TO MODERNIZATION DRIVE

OW120906 Beijing XINHUA in English 0847 GMT 12 Apr 84

[Text] Beijing, 12 Apr (XINHUA)--Computer scientist Liu Weichang (49), the newly-appointed director of the municipal computer institute, has developed a Chinese character processor, now in use in China and exported to Federal Germany, Hong Kong and Singapore.

Civil engineer Wan Siqun (45) regularly inspects underground water, power and other infrastructure facilities at several worksites in the city, and is called by his colleagues a "busy man." He is now deputy director of the municipal construction commission.

Wheat specialist Song Bingyi (54), a well-known agronomist, has summed up his experience of wheat cultivation gained over the past three decades, which helped increase wheat fields in the Beijing area. He recently became president of the city's Academy of Agricultural Science.

Liu, Wan and Song are just three of the middle-aged scientists whom the municipal government has promoted to leading posts in the past year. They just attended a meeting of the Beijing municipal committee of the Chinese People's Political Consultative Conference along with another 660 of the city's intellectuals, who make up over half of the committee.

The proportion of cadres with college education working for the city government has risen to 64.6 percent from 30 percent just a year ago.

The governing bodies of all Beijing's institutions of higher learning and scientific institutes are dominated by college graduates.

Liu Weichang attended China's first computer training session upon graduation in 1956 from Shanghai's Jiaotong University, one of the country's best known polytechnics.

Liu persevered in his studies through the decade of turmoil between 1966 and 1976 to invent the first testing system for computer-controlled circuits in Beijing.

He later pioneered the computerized projection of Chinese subtitles onto television screens and application of computers to Chinese medical diagnosis, civil engineering and scientific research.

"Conditions were not right for my research before," he says. "Now I must try twice as hard to make up for the loss."

He is now concerned with 45 new city projects, including computerization of banking, traffic control at 15 intersections along the Changan Avenue, and reservation at the Beijing, Minzu and other major hotels in the city.

The "busy man" Wan Siqian is now concentrating on 16 million square meters of construction, including four million square meters of housing to be completed this year.

A 1961 graduate of Qinghua University, another top polytechnic institute, Wan helped with installation and interior decoration of the long-distance telecommunications building, the new Beijing indoor stadium, the new Beijing hotel wing, and the Chairman Mao Memorial Hall.

Wheat specialist Song Bingyi now heads a team of 490 agrotechnicians in the Beijing Academy of Agricultural Science, who are working on 147 experimental centers on the outskirts.

In the last 30 years, Song has lectured approximately 100,000 peasants on wheat cultivation and helped improve the technical competence of some 100 middle school graduates. His book on study of wheat crops has sold several hundred thousand copies across China.

The son of an agronomist, he went to Japan to learn agronomy at 17 in 1943. He recalls how in old China poverty-stricken peasants could not use scientific methods of farming.

The city now has 30 agrotechnical schools and 5,500 agrotechnicians on its outskirts. Song Bingyi hopes to enable three million peasants in the area to attain the level of agrotechnical secondary schools by the year 2000.

CSO: 4010/78

APPLIED SCIENCES

STATE S&T COMMISSION APPROVES INVENTIONS

Beijing RENMIN RIBAO in Chinese 21 Dec 83 p 3

["Announcement of the Inventions Evaluation Committee of the State Science and Technology [S&T] Commission"; Asterick indicates recipient is deceased]

[Text] The Inventions Evaluation Committee of the State Science and Technology Commission has recently examined and approved 155 inventions of which 153 are now announced.

First-Class Prizes

- (1) Use of nuclear radiation to develop the new rice strain "Yuanfengzao" (Radiation Breeding Research Group, Institute of Utilization of Atomic Energy, Zhejiang Academy of Agricultural Sciences).
- (2) Antigens 52-128 and 57-681 of high anti-fusarium cotton wilt (Dai Mingjie* [2071 6900 2638], Wu Gongzhen [0702 0501 2182], Pu Shaokai* [5543 1421 2818], Tan Yongjiu [6223 3057 0036] and Yang Dezhong [2799 1795 0112], Institute of Plant Protection and Institute of Cotton Research, Sichuan Academy of Agricultural Sciences).
- (3) Attenuated virus vaccine for equine infectious anemia (Shen Yongxian [3476 2837 7359], Xu Zhendong [1776 2182 2639], He Yusheng [0149 7189 3932], Zhang Shengxing [1728 4141 5281] and others, Harbin Veterinary Institute, Chinese Academy of Agricultural Science).
- (4) Swine fever lapinized attenuated virus vaccine (Zhou Taichong [0719 3141 5897], Fang Shijie [2455 2514 2638], Li Jigeng [2621 4949 1649] and others, China Supervisory Office of Veterinary Medicine; Chen Lingfeng [7115 0407 7364], Animal Husbandry Bureau, Ministry of Agriculture, Animal Husbandry and Fishery; Yuan Qingzhi [5913 1987 1807], Liu Yushan [0491 3768 1472] and Li Weiyi [2621 4850 5030], Harbin Veterinary Institute, Chinese Academy of Agricultural Sciences).

Second-Class Prizes

- (1) Stainless steel anode oxidation technique (Huang Guozhu [7806 0948 2691], Li Lixia [2621 7787 7209], Xu Kexun [1776 0344 5651] and Yan Yongjing [7051 3057 0079], Shanghai Institute of Materials).
- (2) New strain of summer soybean "Yuejin No 5" (Ma Shaniun [7456 0810 0243 and Jiang Yonggui [5637 2837 6311], Heze Prefectural Institute of Agricultural Science, Shandong).
- (3) New rice strain "Liaojing No 5" crossbred from distant hybridization of long-grained nonglutinous and round-grained nonglutinous rice (Yang Shengdong [2799 0524 2639], Shenyang Hunhe Farm, Liaoning).
- (4) Turbo tray with niobium and nickel-based high-temperature alloy GH33A (Fan Juchen [4636 1565 3819] and others, Qiqihar Steel Mill; Wu Xi [6762 3686] and others, Guizhou Liming Machinery Corp; Guo Encai [6753 1869 2088] and others, Academy of Iron and Steel Research, Ministry of Metallurgical Industry; Zhou Ruifa [6650 3843 4099], No 621 Institute of Third Ministry of Machine-Building).
- (5) New abortion drug--crystalline protein of Chinese trichosanthes root (Jin Shanwei [6855 0810 3555] and others, Shanghai Institute of Organic Chemistry, Chinese Academy of Science; Xiong Yongzhou [3574 3938 0719] and others, Shanghai Institute of Cell Biology, Chinese Academy of Science; Liu Guowu [0491 0948 2976], Shenyang Scientific Institute of Planned Parenthood).
- (6) Vertical pellet furnace low-pressure roaster technique (Bu Qin'i [0592 3830 0001], Jinan Iron and Steel Mill).
- (7) New polymerization method and new variety of fluoroplastics 46 (Duan Youlu [3008 0645 5684] and Huang Tingchun [7806 1656 2504], Shanghai Institute of Organic Chemistry, Chinese Academy of Sciences).
- (8) Sequential division of telemetering system (Zhang Qishan [1728 0366 0810], Zhang Mingrui [1728 7686 3843], Liu Yaokun [0491 6460 1024], Ju Feng [7263 2800], Xia Yuwen [1115 1342 5113] and Xing Xiehao [6717 0588 6275], Beijing College of Aeronautical Engineering, Ministry of Aeronautics Industry).
- (9) Safety self-destruction assembly (Lu Jian [0491 2065], Zhang Huitang [1728 2585 1016], Cheng Jidong [2052 4949 2639], Wang Jingfang [3769 7234 5364] and others, Ministry of Ordnance Industry).
- (10) SF501 antifungus agent for optical instruments (Yan Jingjuan [0917 7234 1227], Zhu Dinghui [4281 1353 6540], Ni Guoliang [0242 0948 5328], Qin Shizhang [4440 1102 4545] and others, Ministry of Ordnance Industry).

Third-Class Prizes

- (1) Use of induced control by percussion drilling to prevent bursting of coal and gas in extrusive coal seams capable of flowing (Hydraulic Punching Research Group, Nantong Bureau of Mines, Sichuan; Hydraulic Punching Research Group, Chongqing Institute, Academy of Coal Research).
- (2) Contact network assembly for low net space tunnels (Jiang Wenyuan [5592 2429 3293] and others, Academy of Railway Research).
- (3) T.J4-2 float track gravity vehicle decelerator (Decelerator Special Subject Group, Institute of Signals, Academy of Railway Research, Ministry of Railways).
- (4) Turn wheel continuous steel turnover machine (Wang Ke [3769 0344], Chen Boqin [7115 0130 0530] and Yin Guomou [3009 0948 5399], Chengdu Seamless Steel Tubing Mill).
- (5) Star wheel grain supporter for wide-cut upright strip table of grain harvester (Ma Ji [7456 7535], China Academy of Agricultural Mechanization).
- (6) Techniques of high-speed blowout and air-flow dynamic equilibrium of glow ion nitrogenation (Gao Yangshi [7559 0111 0037], Jiang Chunnian [5637 2797 1628] and Zhang Yongxiang [1728 3057 4382], Machine Tool Research Institute, Ministry of Machine-Building Industry; Li Xiyu [2521 3556 2768], Navy Institute of Automation; Development Group, Beijing Electric Furnace Plant).
- (7) Emersion saltbath furnace of primary pole direct switch on (Lin Zhengzhan [2651 2973 3277] and others, Lanzhou Institute of Petroleum Machinery).
- (8) Synthetic treatment preparation for nontoxic refining and metamorphosis of aluminum silicon alloy (Jie Qidong [6043 6386 2639], Fu Litu [0265 4539 0960], Cao Shengyun [2580 3932 7189] and others, Shenyang Institute of Casting, Ministry of Machine-Building Industry).
- (9) 24-240C velocity water column pneumatic meter (Li Xueshou [2621 1331 2219], Changchun No 1 Motor Vehicle Plant).
- (10) New alloy technique of iron coating and plating (Liang Zhaowei [2733 5128 0251] and Shu Mingxin [2631 2494 9515], Institute of Highway Sciences, Ministry of Communications; Dai Xiangzhong [0108 0686 0022], Yang Huiwen [2799 1920 2429], and Yang Shuying [2799 3219 5391], Yunan Institute of Communication Sciences).
- (11) Cucumber disease-resistant, high-yield complete varieties Jinyan No 1-7 (Hou Feng [0186 6912] and Lu Shuzhen [0712 3219 3791], Tianjin Institute of Vegetables).

- (12) BZ Zonghe seeder (Zhou Jialuo [0719 1367 2867], Wu Qixiang [2976 0796 4382], Wang Mousheng [3769 5399 4141], Zeng Nanhong [2582 0589 1347], Ma Chenglin [7456 0252 2651] and others of various units of Jilin Institute of Agricultural Machinery; Jilin Academy of Agricultural Sciences; Huaide County Planting Machinery Plant, Jilin; Jilin Polytechnical University; Baicheng Prefectural Agricultural Machinery Institute, Jilin; Former Institute of Agricultural Machinery, Jilin).
- (13) Z-7 cultivator (Liu Fang [0491 5364], Liu Detian [0491 1795 1131] and others of units of Jilin Institute of Agricultural Machinery).
- (14) Short-skirt dictyophora phalloidea indoor cultivation technique (Lin Jieneng [2651 2212 5174], Zheng Curong [6774 2806 1369], Zhang Qiuli [1728 4428 5461] and Liu Qingmou [0491 1987 5399], Guangdong Institute of Microbiology).
- (15) Marsh pine needle leaves hygroscopic water cultivation of seedlings (Zhou Xintie [0719 1800 6993] and Yang Chenggui [2799 2110 2710], Jingzhou Prefectural Institute of Forestry, Hubei).
- (16) Synthesis of hormonoid 734-II for larva protection and sericulture technique (Li Ruisheng [2621 3843 5116], Huang Qipeng [7896 6386 7720], Ying Baining [5391 2672 1380], Lao Ruiqian [5071 3843 3383] and others, Zhongshan University; Liu Shixiang [0491 0099 6343] and others, Institute of Sericulture, Guangdong Academy of Agricultural Sciences; Huang Ziran [7806 5261 3544] and others, Silkworm and Mulberry Department, South China Agricultural College).
- (17) High-yield and seedling-raising techniques for fern-shaped man-jianghong sporocarps (Zheng Zhuangta [1728 1104 1044], Ke Yushi [2688 3768 6108], Ling Dequan [0407 1795 0356], Duan Bingyuan [3008 3521 3293] and Liu Xilian* [0491 4406 5571], Institute of Soil Fertilization, Guangdong Academy of Agricultural Sciences; Xiao Qingyuan [5135 1987 0337] and others, Institute of Soil Fertilization, Hunan Academy of Agricultural Sciences; Lu Shuying [0712 2579 4964] and others, Wenzhou Institute of Agricultural Sciences, Zhejiang).
- (18) IJ34KH constant magnetically inductive alloy (He Guoqin [6787 0948 0530], Yang Huilin* [2799 1920 2651] and Xiao Hui [5135 1979], Beijing Institute of Metallurgy).
- (19) Technique of using high-speed chemical gaseous phase deposition to obtain high performance Nb₃Sn zones (Nb₃Sn Superconducting Zone Development Group, Changsha Institute of Mining and Metallurgy, Ministry of Metallurgy; Chen Zhishan [7115 1807 1472], Lai Yuansheng [6351 6678 3932] and Wei Tizhong [7614 7555 0112], Institute of Nonferrous Metals, Ministry of Metallurgical Industry; Institute of Physics, Chinese Academy of Science).
- (20) Nonmagnetic die steel (Zhang Zhenya [1728 7201 0068], Wei Guoneng [7614 2654 5174], Yong Junkui [2837 0193 1145] and Song Chengyi [1345 6134 0001], Academy of Iron and Steel Research, Ministry of Metallurgical

Industry; Yin Shaofen [7113 4801 5358], Beijing Steel Mill' Chu Quanchuan [4281 3123 1557], Chongqing Alloy Steel Mill).

(21) A type of azoic arsine cerium rare-earth developing agent (Yu Ximou [0151 1598 5399], Zeng Yun'e [2582 7189 7725], Cai Ruixiu [5591 3067 4423], Fu Shengnian [2592 0524 1628] and Liang Hanqiong [2733 3352 3890], Wuhan University; Zhu Lutian [4281 0712 3994], Li Zhengli [2521 2182 0448] and Zhou Lihua [0719 0448 5478], Daye Steel Mill).

(22) New technique to remove foreign substance on quartz household utensils (Zou Yuanxi [6760 0337 8764], Tan Lifang [6223 7787 5364] and Liao Liying [1675 7787 5391], Shanghai Institute of Technology, Chinese Academy of Science; Qian Jiajun [6929 1367 0193] and Liang Lianke [2733 6647 4430], Northeastern College of Engineering; Lu Naikun [7120 0035 3824], Shenyang Smeltery).

(23) Machine-woven polyester fiber and fine-haired artificial blood vessel (Qian Xiaoping [6929 1420 5493] and Lin Zenghuan [0651 1073 5478], Suzhou Silk Textile Sample Mill); Pan Zhi [3382 3112] and Rao Tianjian [7437 1131 0256], Shanghai Thoracic Hospital).

(24) Plasma spraying aluminum oxide and zirconium oxide artificial bone and coating material (Ding Chuanxian [0002 0278 6343], Ju Jianzhong [4234 1696 0022], Zhang Yefang [1728 0673 2455] and Lin Huiling [2651 1920 0104], Shanghai Silicate Institute, Chinese Academy of Science; Cao Mingjun [2580 2494 0689], Shanghai First Hospital; Zhang Zhifang [1728 1807 2455], Shanghai Second Hospital).

(25) Nonsurgical sterilization drug "benzol compound phenolic paste (Shanghai Pharmaceutical Industry, Xinhua Hospital Attached to Shanghai Second Medical College, and Shanghai Xinyi Pharmaceutical Plant).

(26) Nondeveloping gaseous phase photoetching technique (Pei Yongxiang [5952 2837 4382], Nanjing Power Automated Equipment Plant, Ministry of Water Resources and Electric Power; Jin Weixin [6855 4850 2450], Institute of Semiconductors, Chinese Academy of Science, Hong Xiaoling [3163 0876 5129], Beijing Institute of Chemical Engineering and Han Jieping [7281 0094 1627], Institute of Semiconductors, Chinese Academy of Science).

(27) Antimony, manganese, zirconium, titanium and lead (PMS) piezo-electric ceramics (Zhang Fuxue [1728 4395 1331], Liu Yisheng [0491 0001 5116], Xu Huifang [1776 1979 5364], Wang Mieqi [3769 5019 3825] and others, No 26 Institute, Ministry of Electronic Industry).

(28) High carrier frequency (200 Kilohertz) differential transformer, displacement transducer and JDW-1 displacement telemeter (Li Chu [2621 2806] and others, Wuhan Institute of Rock and Soil Mechanics, Chinese Academy of Science).

(29) High voltage, high-power ionization vacuum gauge (Guo Yuanheng [6753 0337 1854], Beijing University).

- (30) ZJ rectangular plug and T common axle plug with twin-boss internal spring mechanism (Shen Yixun [3476 0076 8113], No 158 State-operated Plant, Ministry of Aeronautics Industry).
- (31) Standard mass manufacturing technique (Wu Wenbing [0702 2429 3521], Lin Wangong [0651 1238 1872], Miao Zhixin [4924 2535 1800], Fu Zengji [0265 1073 6060] and others, No 303 Institute, Ministry of Aeronautics Industry; Tian Guanghe [3944 1684 0735], No. 304 Institute, Ministry of Aeronautics Industry; Wang Chenggang [3769 2110 0474], China Institute of Metrology).
- (32) A kind of four-pole substance filter (Xue Zuqing [5641 4371 1987], Dhrn Honhyun [3947 0501 6663] and Lu Jiahe [7120 1367 0735], Qinghua University; Wang Moran [3769 1075 3544] and Chen Wanyi [7115 5502 0308], Shenyang Teaching Instrument Plant).
- (33) 115 rosin unsaturated polyester-resin anchor mixture (Zheng Zhongyuan [6774 6850 6678] and Huang Naijiong [7806 0035 3518], Beijing Institute of Well-Building, Academy of Coal Research, Ministry of Coal Industry; Wu Dali [0702 1129 4539], Synthetic Material Plant, Huai'nan Bureau of Mines; Zhou Juxing [0719 5468 5281] and others, Chemistry Department, Beijing Normal University).
- (34) Phenolic butanenitrile high elasticity adhesive (Wang Zhilu [3769 5268 4389], Wang Wenju [3769 2429 5282], Wang Suai [3769 4790 8302] and Zhong Yunjie [6988 7189 2638], Heilongjiang Institute of Petroleum Chemicals).
- (35) New method to produce polyphenyl dibenzyl sulfone (Chen Yuanyin [7115 6678 5593], Liu Huiying [0491 1920 5391], Liu Jiwan [0491 1015 5502], Fu Shali [0265 5446 5461] and others, Chemistry Department, Wuhan University; Huang Zhaoji [7806 0340 0679] and Tian Mingyu [3944 2429 3768], Wuhan Chemical Raw Materials Plant).
- (36) Composition of supersensitized dyestuff and its application (Shi Nianci [0670 1819 1964], Wang Zuqiang [3769 4371 1730] and Yang Suqing [2799 4790 0615], East China College of Chemical Engineering).
- (37) New method to synthesize imino group disulphuric amonia (Li Shengze [2621 5116 3419], Zhang Mingxiang [1728 2494 4382] and Wei Fuqun [7614 4395 5028], Southwestern Normal College).
- (38) CM copper rare-earth oxide hive-combustion catalyst (Wang Ren [3076 0088], Wu Shanliang [0702 0810 5328], Zhang Zhigang [1728 1807 0474], Wang Lizhen [3769 0448 6297] and others, East China College of Chemical Engineering).
- (39) New technique to produce hydrogen peroxide solution by electrolysis (Xie Jifa [6200 4949 4099], Li Jisen [2621 1015 2773] and others, Shanghai Institute of Organic Chemistry, Chinese Academy of Science; Wu Junqi [0702 7486 0366], Yu Weichao [0205 4850 2600] and others, Jiangyin No 1 Chemical Plant, Jiangsu).

- (40) Low temperature sintering of acid-proof and alkali-proof enamel (Li Yunpeng [2621 7189 7720] and Shi Xiaofeng [2457 1321 6646], Shanghai Silicate Institute, Chinese Academy of Science; Zhuang Linyong [8369 2651 2837], Shanghai Industrial Enamelware Plant).
- (41) Use of lemon cajeput oil to synthesize musk oxalic phenol (Yang Zeyu [2799 3419 2810], Deng Weici [6772 5898 1964] and Lin Guangxiong [2651 0342 7160], Guangzhou Institute of Chemistry, Chinese Academy of Science).
- (42) Ultraviolet spectrum laser dyestuff and its synthesis (Gao Zhenheng [7559 2182 5899], Zhou Yimin [0719 0001 3046], Pan Jiaying [3882 1367 2622], Wang Mingzhen [3769 2494 4176] and others, Nankai University).
- (43) Rare-earth perovskite--alloyed hive-exhaust purifying catalyst (Xu Jinhang [1776 6930 5300], Beijing Industrial University).
- (44) JFA membrane material and its application in chromium-plating wastewater rinse (Liu Guoxin [0491 0948 0207] and Wu Jiangjin [2976 3068 3160], Beijing Institute of Environmental Protection; Gao Yiheng [7559 0110 1854], Wu Lingling [0702 3781 3781] and Ling Ailian [0407 847 5571], Beijing Industrial University; Ji Zhaoyong [4764 6389 0516] and Liu Gang [0491 2492 2837], Beijing Broadcasting Equipment and Materials Plant; Zhou Kunyong [0719 2492 2837] and others, Tenth Design Institute, Ministry of Electronics Industry).
- (45) Twin-jet flame holes of gas singeing machine (Qin Guizhi [4440 6311 3112], Zou Yushu [6760 3768 2579] and Meng Zhangliang [1322 4545 5328], Chengdu University of Science and Technology; Xiao Fusen [5135 4395 2773] and Li Xiandao [2621 0341 1418], Chengdu Dyeing Mill).
- (46) Electric salt-bath furnace fast-starting method (Zhang Qingde [1728 1987 1795], No 304 State-operated Plant, Ministry of Ordnance Industry).
- (47) QXT-01 digital tilted revolving stage (Li Shiling [2621 1102 0109], Ma Zhizhou [7456 2535 0719], Lu Xia [7627 7209] and others, Ministry of Aeronautics Industry).
- (48) 14-node mixed stiffness limited element (Zhou Tianxiao [0719 1131 1321], Yang Ping [2799 1627], Xing Jianmin [6717 1696 3046] and others, Ministry of Aeronautics Industry).
- (49) HZL-205 high intensity forged aluminum alloy (Liu Bazao [0491 0130 2347], Xiang Qiyan [0686 0796 1031], Li Wenlin [2621 2429 2651], Zhang Yunkang [1728 0336 1660] and others, Ministry of Aviation Industry).
- (50) Air-float electronic scale capable of measuring micromoments of force (Wang Hongyuan [3769 3163 3293] and GuShenyi [7357 0686 0001], Ministry of Aeronautics Industry).

- (51) JOY-1 precision blade die surface-check instrument (Liu Xiang [0491 3276], Zhang Shumin [1728 3219 2404] and Liu Ruilin [0491 3843 7792], Ministry of Aeronautics Industry).
- (52) Z022CrMnMo low-alloy, high-intensity, high-tenacity cast iron (Sun Fangce [1321 2455 4595], Lao Riling [0525 2480 3781], Zhang Ming* [1728 2494] and others, Ministry of Aeronautics Industry).
- (53) Single-blade double-camber coil spring socket assembly machine (Cai Huijin [5591 1920 2516] and Wu Jingchang [0702 6975 2490], Ministry of Aeronautics Industry).
- (54) Blast-spraying equipment (Feng Yaokun [7458 5069 0981], Chen Jianping [7115 1696 1627], Mi Qingtian [4717 7230 3944] and others, Ministry of Aeronautics Industry).
- (55) Twin-blade fluid-scale fluid-floated gyro-float static equilibrium measuring instrument (Shen Ruoying [3476 5387 5391], Yuan Guikang [5913 6311 1660], Wang Shengyan [3769 4141 6056] and others, Ministry of Aeronautics Industry).
- (56) Closed-formation explosive-forming machine tool (Zhang Shibiao [4545 0099 9473], Zhong Faxian [6988 4099 6343], Zhang Guozhen [1728 0948 3791] and others, Ministry of Aeronautics Industry).
- (57) BHP-800A adhesive single-wire temperature self-compensating strainometer (Ma Liangcheng [7456 5328 (?)], Wu Zongdai [0702 1350 1486], Zhao Linpao [6391 2651 6283] and others, Ministry of Aeronautics Industry).
- (58) Vibration stand used in air-float mode respond tests (Gui Shigong [2710 0013 0501], Ministry of Aeronautics Industry).
- (59) Three-way radio acoustic zero dispatch test probe (Zhu Pingyue [4281 1627 2588] and He Yijin [0149 2022 2516], Ministry of Aeronautics Industry).
- (60) Manufacturing technique for catalyst and shunt plate used in catalytic igniters (Ma Deliang [7456 1795 5328], Wang Futian [3769 1381 3944], Wu Yun [0702 7189] and others, Ministry of Aeronautics Industry).
- (61) New iron-based sinter friction materials (Task Group of Li Dongsheng [2621 2639 3932] and others, Ministry of Aeronautics Industry; Development Group of Chu Yuanjie [0443 0337 2638] and others, Beijing Friction Material Plant).
- (62) Fuse outer ballistic rotational speed analog test method and installation (Xu Jiazhen [1776 1367 4394], Wang Xiequn [3076 0588 5028], Li Dingjian [2621 1353 6169] and others, Ministry of Ordnance Industry).

- (63) New structure of track guide-2 (Zhang Jingyu [1728 7231 1342], Liu Jingquan [0491 6855 6898], Gong Chengjun [7895 2110 6511], Liang Huayong [2733 5478 2937] and others, Ministry of Ordnance Industry).
- (64) New friction ignition powder (Wang Yougui [3769 2589 6311], Su Shuanzhi [5685 2633 2535], Gao Fayu* [7559 3127 2768] and others, Ministry of Ordnance Industry).
- (65) New piezoelectric fuse of safety mechanism (Liu Fuxiang [0491 4395 4382], Liu Wencheng [0491 2429 2052], Wu Hongjun [0702 7703 6874], Liu Mingjie [0491 2494 2638], Tan Huimin [6223 1920 3046], Ma Baohua [7456 1405 5478] and others, Ministry of Ordnance Industry).
- (66) 64SCF cartridge (Yuan Shangxian [0626 1424 6343], Xiao Cuirong [5135 5050 5554], Shi Jinsheng [0670 6855 0581] and others, Ministry of Ordnance Industry).
- (67) Primer exterior-pick machine tool (Liang Chengju [2733 2052 5282], Sun Yonghua [1327 3057 5478], Duan Huifa [3008 6540 1381] and others, Ministry of Ordnance Industry).
- (68) Copper and iron internal electrolytic treatment of mercury fulminate wastewater (Yang Dejun [2799 1795 0193] and Dong Xi [5516 3886], Ministry of Ordnance Industry).
- (69) Saturated coal heat reproduction technique and assembly for the adsorption of nitrocompounds in acidic wastewater (Guan Ping [7070 0988], Lu Yongsen [7120 7167 2773], Qiu Jinwu [6726 6930 0710], Lin Tai [2651 3141] and Dou Cixiang [4535 1964 4382], Ministry of Ordnance Industry).
- (70) Ion-exchange method to treat wastewater of cyaniding copper and tin plated alloys and the recovery of cupric sodium cyanide (Fan Zhengjiang [2868 2182 3068] and Chen Zhida [7115 1807 6671], Ministry of Ordnance Industry).
- (71) New technique to manufacture ball powder (Su Ziqiang [5685 5261 1730], Zheng Yimu [6774 0110 2606], Yang Chuanguo [2799 0278 2654] and others, Ministry of Ordnance Industry).
- (72) Technique of inlaying double-based propellant with long metallic wire (Chen Shulin [7115 5289 2651] and Li Fengsheng [2621 7685 3932], Ministry of Ordnance Industry).
- (73) Metallic wire coating and manufacturing technique (Li Fengsheng and Chen Shulin, Ministry of Ordnance Industry).
- (74) Adjustable elliptic spotlight cavity process assembly (Zhang Bingquan [1728 3521 2938], Ministry of Ordnance Industry).

(75) Nonswaying compensation machining for ring diamonds grinding tools (Liu Shaodong [0491 4801 2635], Zhang Jiashan [1728 0857 3790] and Wu Yinghua [2976 5391 5478], Ministry of Ordnance Industry).

(76) Determination of solid soluble nitrogen in gaseous carbon nitrogen copermeated layers (Nie Changshen [5119 1603 4800], Ministry of Ordnance Industry).

(77) 83-1 motar (Shu Xiantong [2631 6343 6639], Guo Shuhui [6753 0647 6540], Li Shuyong [2621 2885 2837], Tian Xuewen [3944 1331 2429], Nan Zijiang [0589 1311 3068], Shen Lanying [3476 5695 5391] and others, Ministry of Ordnance Industry).

(78) Application of low silver content copper silver alloy material (Chao Ruizhi [6392 3843 0037] and Kang Lianfu [1660 6647 4395], Ministry of Ordnance Industry).

(79) Regulation of equisection steel pipe working frequency induction (Feng Weinian [7458 0251 1628], Zhang Huilin [1728 1920 2651], Chen Yanxing [7115 1693 5281] and others, Ministry of Ordnance Industry).

(80) Two-way fluid-feed multicavity electrolytic process cathode (He Xiande [0149 7359 1795], Ministry of Ordnance Industry).

Fourth-Class Prizes

(1) Thistle board caulking putty (Wang Meijun [3749 5019 0689] and Fei Weiwei [6316 1979 1979], Institute of Architectural Engineering, First China Bureau of Building).

(2) Hydraulic engine value type hydraulic piston pump and commutation mechanism (Shenyang College of Aviation Industry; No 251 Plant, Shenyang College of Aviation Industry; Institute of Oil Extraction Technology, Shengli Institute of Oilfield Drilling; Wang Weixian [3769 3634 0341], Tongji University).

(3) Generalized multicasing bar0linkage automatic program control method and its application in 50-ton automatic pipe contractor (Fan Zhaolai [4636 2600 0171], Changchun Locomotive Plant, Ministry of Railways).

(4) High horsepower diesel engine forged steel crankshaft ion nitrogenation technique (Crankshaft Ion Nitrogenation Key Task Group, Beijing No 27 Locomotive Plant; Zeng Yaixin [2582 5069 2450], Xu Bingzhong [1776 3056 0112], Hu Yongjing [7579 2837 7234] and Deng Yang [6772 3152], Institute of Metals and Chemistry, Ministry of Railways Academy of Science).

(5) Glow discharge anode power transmission assembly (Gao Yangzhi, Machine Tool Research Institute, Ministry of Machine-Building Industry; Shen Shichang [3476 0013 2490], Beijing Institute of Heat Treatment; Lu Xhixin [5684 0013 0207] and Li Zhimin [2621 1807 2404], Beijing Electric Furnace Plant).

- (6) Expanded osmotic technique of ionic bombardment for encased surface of austenitic steel (Yang Lieyu [2799 3525 1342] and his development group, Dalian College of Marine Transportation).
- (7) Low-power high-speed brushless motor (Wang Zhenguo [3076 6966 0948], Weng Dazhen [5040 1129 3791] and Zhang Xinwei [1728 0207 0251], Shanghai Power Tool Institute).
- (8) Roller-oscillating movable circular gear drive (Xu Yonghsien [1776 3057 6343] and Liu Zuoliang [0491 4373 5328], No 221 Plant).
- (9) Casting of K13 iron-nickel-chromium-based high-temperature alloy (Sun Jiahua [1321 1367 5478], Xie Yunpeng [6200 7189 7720], Yang Zhengfen [2799 2973 0416], Wang Bin [3769 2430] and others, Academy of Iron and Steel, Ministry of Metallurgical Industry).
- (10) Utilization of high-volatility low-cohesiveness Datong coal in coking and mixing coal (Wang Wuyan [3769 0063 6056] and Wang Wenxin [3769 2429 0207], Capital Iron and Steel Corp; Han Wenbao*[7281 2429 5508] and Zhou Siyong [0719 1597 1661], Anshan Institute of Metallurgy and Thermal Energy; Li Tianduo [2621 1131 6995] and Wang Zutong [3769 4371 0179], Shanxi Institute of Coal Chemistry, Chinese Academy of Science; Xu Hengpu [1776 1854 2528] and Liu Jinzhi [0491 6930 5347], Taiyuan Iron and Steel Corp; Coking Plant, Xuanhua Iron and Steel Corp).
- (11) Ceramic manufacturing of highly purified niobium oxide crucible (Jiang Minde [3068 3046 1795], Jiujiang Nonferrous Metal Refinery; Wang Yinghuai [3769 2019 2849], Hongxing Ceramics Plant, Jingde).
- (12) MB-2 pulsating water massager (Wang Yucheng [7806 7183 0252] and Zheng Baoan [6774 0202 1344], Institute of Sports, State Physical Culture and Sports Commission).
- (13) Clinical preservation treatment for vertically split teeth (Shi Shujun [0670 2579 0193], Hou Zhiyan [0186 5347 5333] and Wang Zhengkun [3769 2973 0981], Tianjin Medical College).
- (14) Soluble haemostatic gauze (Xue Digeng [5641 6611 1649], Wang Zhaorui [3769 8734 6904] and Zhang Mei [1728 9485], Beijing Institute of Textile Science; Cai Qinghua [5591 1987 5478], Xuanwu Hospital Attached to Beijing Second Medical College).
- (15) Ring-supported movable rectifier (Mao Xiejun* [3029 3610 0971], Wang Jinfang [7806 6855 5364], Xie Yiyue [6200 0110 1471] and Xu Ruifang [6079 3843 5364], Institute of Stomatology, Beijing Medical College).
- (16) Ruby crystal I-level optical surface polishing technique (Zhang Xinde [1728 1800 1795], Eleventh Institute, Ministry of Electronics Industry).

- (17) Detection of flashing arc using blue-purple silicon photo tube with self-checking of light source (Zhang Fengsheng [1728 3539 3932], Qi Pizhi [7871 0012 2535], Wang Yangping [3769 1693 1627] and Hu Suchun [5170 3219 4783], Wuhan University).
- (18) Multiple-point object position memory switch (Li Huaicheng [2621 2037 0252], Beijing No 4 Automatic Meter Plant).
- (19) Application of fluorescent inversion technique in mercury meters (Wu Xingliang [0702 1840 5328], Yu Wenbo [0205 2429 3134], Song Hongzi [1345 7703 6961] and Deng Jiaqi [6772 1367 4388], Fudan University).
- (20) High-strength silica heat-resistant adhesive (Li Dingyi [2521 1353 1138], Zhang Ruo [1728 (?)], Zhang Shilin [1728 6108 2651] and Zhang Xiongqiang [1728 7160 1730], Hunan Institute of Machinery).
- (21) Improved technique of carbon oxysulfide synthesis (Yu Zhongxin [0151 0022 1800], Wang Shengbo [3076 5116 0130], Xiao Guangpu [5135 0342 2528], Ye Jingxia [0673 2529 7209] and others, Hunan Chemical Institute).
- (22) Solvent method to extract and purify humic acid in Gongxian County efflorescent coal (Ju Deji [6508 1779 1015], Zhang Hongyun [1728 3163 0061] and Lu Shuanghe [4151 7175 3109], Chemistry Department, Zhengzhou University; Wang Mouye [3769 5399 2814] and Wu Shuqin [2976 3219 3830], Coal Institute, Gongxian County Science Committee; Zhang Baio [1728 2871] and Peng Xingbang [1690 5281 1620], Gongxian County Compound Fertilizer Plant).
- (23) Solid acid catalyst with esterified reaction (Wang Huamin [7806 0553 3046], Na Chongwu [6719 1504 2976], Zhang Yushan [1728 3768 1472], Xu Zhiluo [1776 0037 7170] and others, Jilin University, Zhang Cuntai [1728 1317 3141], Jia Jingshun [6328 2529 4226] and Li Suhua [2621 4790 5478], Beijing No 3 Chemical Plant).
- (24) Technique using molecular sieve to make coke from anthracite (Zhong Dexuan [6988 1795 0826], Liu Guangqing [0491 1684 3247], Yang Guofu [2799 0948 7450], Liu Guifu [0491 2710 7450] and others, Jilin Petroleum Chemical Institute).
- (25) Gaseous phase solidification of epoxy resin and coatings (Shen Yi [3476 3015], Hangzhou Printing Ink and Paint Plant).
- (26) New technique to collect grain vitamins (Tao Jun [7118 6874], Wuxi Institute of Research and Design in Food Science, Jiangsu; Tang Gongye [0781 0501 2814], Changzhou Oil Plant).
- (27) High-temperature high-radiation far-infrared coatings (Liu Dexing [0491 1795 5281], Jiang Jundai [5637 0193 1486] and Mou Lifa [3664 4539 3127], Shijiazhuang Prefectural High Voltage Switch Plant).

- (28) Waterproof and oilproof vapor permeable coating cloth (Zhou Hong [0719 (?)], Chen Shuilin [7115 3055 2651] and Yang Wenlin [2799 2429 3829], East China College of Textile Engineering).
- (29) Hydro heavy nitrogen photo-sensitive film (Zhou Hong, Zhu Jianhua [4281 1696 5478] and Zhang Naili [1728 0035 4539], East China College of Textile Engineering; Hu Shoukang [7579 1108 1660], Shanghai No 3 Silk Printing Mill' Lu Xaiyi [7627 0961 1544], Shanghai Institute of Prospecting).
- (30) New technique of antislip agent for polyolefin weaving (Gao Jingchen [7559 2529 2525], Wang Yun [3769 7189], Chen Yuyong [7115 2768 2837], Zheng Kunhan [6774 2492 3352] and others, Beijing Institute of Chemical Fiber).
- (31) Automatic draw-in machine (Yang Zonglin [2799 1350 2651] and others, Shijiazhuang Institute of Textile; Cai Xiyuan [5591 6007 0954] and others, Beijing No 2 Cotton Textile Mill; Wang Yinghua [3769 5391 5478] and others, Beijing No 3 Cotton Textile Mill; Zhao Yongyao [6392 3057 5069] and others, Qingdao Draw-in Machinery Development Group, Shandong; Liu Qingen [0491 1142 5327] and others, Draw-in Machinery Development Group, Henan Bureau of Textile Industry; Wang Qifa [3769 0796 4099] and others, Draw-in Machinery Research Group, Shanghai Second Textile Corporation).
- (32) Precision hydraulic iron fender fixed-position assembly (Wu Minggen [0702 2494 2704], Yuan Zhenkun [5373 2182 0981] and Zhang Canhai [1728 3503 3189], Ministry of Aeronautics Industry).
- (33) Use of modified varnish and plying technique for methacrylic and butyl ester sandwiched bulletproof glass (Zhang Yunge [1728 7189 7041], Lin Wanyi [2651 5502 5030] and Lin Dunyi [2651 6253 0308], Ministry of Aeronautics Industry).
- (34) Compound ceramics (BK52-BPB) of enlarged natural diamond lumps (Wang Zuhong [3769 4371 1347], Ministry of Aeronautics Industry).
- (35) 35 x 540 fluid static deep-penetration rounded grinding pole (Zhang Xisheng [1728 6932 5110], Ministry of Aeronautics Industry).
- (36) Material and technique of sand-inland forged-iron mull plates (Wang Xuan [3769 1357], Ying Aichun [2019 1947 2504], Yu Dajen [0151 6671 0088], Sun Bingyong [1327 3521 2837] and others, Ministry of Aeronautics Industry).
- (37) Application of optical projection display method on O-type metallic sealed rings in welders (Xue Wenxi [5641 2429 3556], Chen Liuxiang [7115 3966 4382], Ye Decheng [0673 1795 2052] and others, Ministry of Aeronautics Industry).
- (38) Single or double electrothermal work bench for titanium alloy heat-formed and heat-adjusting machine tools (Chen Chunkui [7115 2504 1145] and others, Ministry of Aeronautics Industry).

- (39) Aluminum-rolling connection technique using antiwelding agent (Zhang Yuxiang [1728 3768 4382], Ji Wenhai [4764 2429 3189], Song Feiling [1345 7378 7227], Shi Chunti [2457 4783 1912] and others, Ministry of Aeronautics Industry).
- (40) JMD-2 twin loop crystal tube compounded pulse mains--machining of aeroengine flame tube divergent walls (Liu Xiuqing [2692 4423 3237], Ministry of Aeronautics Industry).
- (41) Use of high-intensity plastic wood to manufacture cast dies (Zhang Bingdong [1728 4426 2767], Zhang Renliang [1728 0088 2733] and Xu Junge [6079 0971 7041], Ministry of Aeronautics Industry).
- (42) Aneroid hydrogen diffusion purifying element with plane stop motion double spacer airways (Chen Zhenzhong [7115 2182 5907], Bai Yuzhen [4101 5148 2823] and Shi Xueyao [1597 1331 1031], Ministry of Aeronautics Industry).
- (43) Piezocrystal laser automatic positioning assembly (Wang Youchen [3769 2589 5256], Kong Yao [1313 2565], Wang Yunchen [3769 6663 5256] and others, Ministry of Aeronautics Industry).
- (44) Digital vernier logic circuit (Tong Xingyong [1547 2502 2837], Ministry of Aeronautics Industry).
- (45) GJ312 vertical collimating lens (Zhao Kun [6392 6924], Wang Jinyu [3769 6930 2768], Liu Wanfa [0491 5502 4099], Liang Suping [2733 3219 1627] and others, Ministry of Aeronautics Industry).
- (46) Inverse characteristic value method in the design and control of vibration of flight instruments (Song Zenghao [1345 1073 3185], Gao Fuan [7559 4395 1344] and Liu Ruiqing [0491 3843 1987], Ministry of Aeronautics Industry).
- (47) 128-electric vortex displacement meter (Li Ruihua [2621 3843 5478] and others, Ministry of Aeronautics Industry).
- (48) 800°C inorganic strain cementation mixture (Bian Hongzhi [6708 7703 1807], Chen Qianzhi [7115 3677 3112] and Liang No [2733 1226], Ministry of Aeronautics Industry).
- (49) New type of rotor safety mechanism (Kuang Zheng [0562 2973], Wang Shulai [3769 0647 0171], Dai Fuying [0108 4395 5391] and others, Ministry of Ordnance Industry).
- (50) Delay charge remover (Wang Minghu [3769 6900 2479], Ministry of Ordnance Industry).

- (51) New stability device for ammunition (Wu Kanzhang [0702 0170 4545], Wang Bingwu [3769 4426 2976], Sun Zubao [1327 4371 1405] and others, Ministry of Ordnance Industry).
- (52) High-speed aperture-check machine (Huang Linqiao [7896 7207 2884], Li Yumou [2621 5124 5399], Fu Qixiu [0265 0366 4423] and others, Ministry of Ordnance Industry).
- (53) New method to treat the waste gas ethylene oxide (Yang Dejun [2799 1795 0193], Zhu Zhengxue [4281 2973 1331], Deng Honggui [6772 3163 6311], Jin Chaojiang [6855 3390 3068] and others, Ministry of Ordnance Industry).
- (54) New technique of nonchromium passivation of primer casing (Liu Yuanshun [0491 0337 7311], Song Caosheng [1345 5430 3932], Yu Zhifang [0205 1807 5364], Xu Xi [1776 0296] and others, Ministry of Ordnance Industry).
- (55) New absorption technique for solvent recovery in distillation towers (Li Kexie [2621 0344 3610], Ministry of Ordnance Industry).
- (56) Luminous quenching solid coating protection technique (Li Wubin [2621 1976 2430], Ministry of Ordnance Industry).
- (57) New technique of heat treatment and intensification in press die forging (Harbin Polytechnic University; He Shiyu [0149 0013 4416], Feng Xiaozeng [7458 2556 2582], Zhang Yulan [1728 2768 5695], Cui Baoshu [1508 0202 2873] and Zhang Baohua [1728 1405 5478], Ministry of Ordnance Industry).
- (58) Compound copper-steel plate working frequency induction heating (Fu Zhengbo [0265 2973 0590], Feng Weinian [7458 0251 1628], Zhang Huilin [1728 1920 7792], He Zhumin [0149 4554 2404] and others, Ministry of Ordnance Industry).
- (59) New heat-treatment technique for deformation of tube-shaped high-tensile steel components (Harbin Polytechnic University; Lei Tingquan [7191 1694 2938], Gao Caiqiao [7559 1752 2890] and Lu Yang [7120 2254], Ministry of Ordnance Industry).

9586

CSO: 4008/100

OPTIMIZATION DESIGN OF EARTH ORBIT REENTRY VEHICLE CONFIGURATIONS FOR MINIMUM AERODYNAMIC HEAT TRANSFER

Mianyang KONGQI DONGLIXUE [ACTA AERODYNAMICA SINICA] in Chinese No 3, 1983
pp 38-46

[Article by Zhou Qicheng [0719 0366 2052] and Wang Zhonglian [3769 0112 5571]]

[Text] I. Introduction

It is well known that spheres and sphere-cones are two of the traditional aerodynamic configurations used for near-earth-orbit reentry vehicles. But from the point of view of protection against reentry heating, they are not the ideal shapes; better aerodynamic configurations can be found by performing optimization design calculations.

Refs. [1, 2] investigated the problem of minimum-heating nose configuration of a missile with constant ballistic coefficient; Ref [3] extended the problem to that of determining minimum reentry heating configuration with volume constraint; Ref. [4] studied the problem of minimum reentry heating configuration for a given reentry weight. The above studies show that a flat nose body of revolution can significantly reduce the total heating during reentry flight.

The primary design parameters of a near-earth-orbit reentry vehicle include the total weight, the effective volume, the longitudinal and lateral dimensions, and reentry flight stability and landing speed requirements. The objective of optimization design of vehicle configuration is to minimize reentry heating while satisfying all the design requirements. Preliminary analysis shows that increasing the effective payload capacity and lowering the speed of descent reduce the total heating during reentry. For example, by reducing the ballistic coefficient, it is possible to reduce the reentry heating as well as increase the effective payload capacity and lower the speed of descent. Therefore, in this article, the speed of descent and payload capacity requirements are neglected; the problem being considered here is the minimum-heating configuration for total weight and fineness ratio and for specified longitudinal aerodynamic stability.

The distribution of surface heat flux is calculated using the widely accepted theory of boundary layer heat transfer; the surface pressure distribution and aerodynamic coefficients are calculated using the extended velocity

distribution law and the modified Newtonian theory. By selecting the total reentry heating given in Refs. [3-4] as the objective function, and considering stability requirements and certain special requirements on geometric shapes, the problem is formulated as a constrained non-linear mathematical programming problem. The optimization solution is obtained using the interior penalty function technique and the variable scale technique.

The three numerical examples at the end of this article show that an approximate flat nose double-cone configuration not only minimizes reentry heating but also provides improved longitudinal aerodynamic stability.

II. Problem Statement

1. Objective Function

By using the commonly accepted Lee's laminar heat transfer equation [5] and the Vaglia-Laurin turbulent heat transfer equation [6]

$$q = \frac{c_n \rho_n V_\infty H_0}{\left(\frac{\rho_n V_\infty R_B}{\mu_0} \right)^{1/n}} \cdot \left[\int_0^1 \frac{\bar{\rho}_e \bar{u}_e \bar{\mu}_e y^{\frac{1}{n}-1}}{\bar{\rho}_e \bar{u}_e \bar{\mu}_e y^{\frac{1}{n}-1}} ds \right]^{1/n}$$

one can calculate the surface integral along the flat nose body of revolution as shown in Fig. 1, and the integral along the flight trajectory by using Chapman's approximate trajectory equation to obtain the total heat transfer during reentry, Q:

$$Q = A_m(V_E, R_B) B(\theta_E) \left\{ \frac{I[x(y)]}{\frac{C_D A}{M}} \right\}^{1-\frac{1}{n}}$$

where A_m is a constant related to the reentry velocity V_E and the base radius R_B , B is a constant related to the reentry angle θ_E , see Refs. [3-4] for details. $I[x(y)]$ is an integral related to the geometric shape of the vehicle and the surface pressure distribution \bar{P} .

$$I[x(y)] = \int_0^{y_1} \bar{P}^a (1 - \bar{P}^b)^{0.5} y^{\frac{a}{n}-1} dy + \int_{y_1}^1 \bar{P}^a (1 - \bar{P}^b)^{0.5} (1 + \dot{x}^2)^{0.5} dy$$

$$a = \frac{1}{K} [1 + (K-1)\omega], \quad b = \frac{K-1}{K}, \quad \dot{x} = \frac{dx}{dy}$$

Figure 1. Schematic Diagram of a Flat Nose Body of Revolution

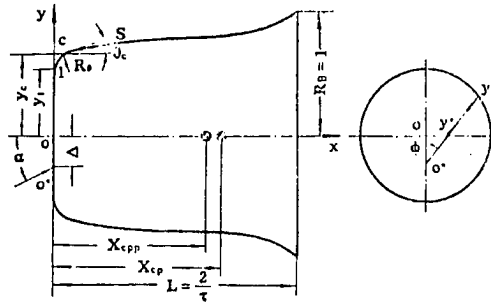

It is obvious that the problem of solving for the minimum-heating configuration for a given reentry weight and fineness ratio can be reduced to one of determining the curve $x(y)$ which minimizes the functional

$$F[x(y)] = I[x(y)]/C_D \quad (1)$$

2. Constraint Condition

The boundary condition at the end point of the base for $x(y)$ is

$$x(1) = 2/\tau \quad (2)$$

The longitudinal stability of the reentry vehicle can be expressed in terms of the longitudinal position of the center of pressure. If X_{cpp} denotes the required longitudinal position of the center of pressure in the angle of attack range $0 \sim \alpha_p$, then the center of pressure X_{cp} of the minimum-heating configuration $x(y)$ must satisfy the following design constraint condition

$$x_{cp} \geq x_{cpp} \quad 0 \leq \alpha \leq \alpha_p$$

Within a range of relatively moderate angles of attack, the position of the center of pressure varies slowly with angle of attack. For computational simplicity, we may express this constraint condition in discrete form:

$$x_{cp} \geq x_{cpp} \quad \alpha_i = 1, 2, 3, \dots, m_1 - 1, \alpha_p$$

or

$$g_i = x_{cp}(\alpha_i) - x_{cpp} \geq 0 \quad i = 1, 2, \dots, m_1 \quad (3)$$

The flat-nose bodies of revolution given in Refs. [1-4] all have sharp corners at the intersections of the flat nose and the body of revolution. Since such discontinuities cannot be allowed in engineering design, they are smoothed using small circular arcs (with continuous first derivatives); the radius R_0 of the circular arc is chosen to be of a certain ratio γ to the flat nose height. Therefore, the surface equation $x(y)$ should satisfy the following smoothing condition:

$$\begin{aligned} x_{c-} &= x_{c+} \\ \left. \frac{dx}{dy} \right|_{x=x_{c-}} &= \left. \frac{dx}{dy} \right|_{x=x_{c+}} \end{aligned} \quad (4)$$

In order to prevent severe disturbance due to viscous interaction between the shock wave and the boundary layer, the surface of inclination angle of the aft body is chosen to be greater than zero, and the flow deflection angle $\Delta\theta$ is chosen to be less than the so-called initial separation angle θ_i of the shock wave-boundary layer interaction. The initial separation angles θ_i for two-dimensional compressive laminar [8] and turbulent corner flows [9] are given respectively by the following empirical formulas:

$$\theta_{iL} = 80 (0.75)^{1/4} \frac{Me^{1/2}}{Re_x^{1/4}}$$

$$\theta_{iT} = 53 \frac{Me^{1/2}}{Re_x^{1/10}}$$

where the coefficient 53 is derived from experimental data of turbulent boundary layers in Refs. [8, 10, 11]. For a typical near-earth-orbit reentry vehicle, the calculations show that during the stage when major aerodynamic heating takes place, $\theta_{iL} \geq 15^\circ$, $\theta_{iT} \geq 30^\circ$. Considering the fact that the cold-wall effect ($T_w/T_0 \sim 0.1$) discussed in this article may increase the initial separation angle of laminar flow, and the uncertainties in initial separation angle of turbulent flow due to fluctuations in Reynolds Number, we introduced the assumptions $\theta_i = \theta_p = 15^\circ$ and $\Delta\theta \leq \theta_p$ to simplify the calculations, i.e.,

$$\begin{cases} \theta(y) \geq 0 \\ \theta(y) - \theta_c \leq \theta_p, & y_c \leq y \leq 1 \end{cases}$$

This equation can also be expressed in the following discrete form:

$$\begin{cases} g_j = \theta(y_j) \geq 0 & j = 1, 2, \dots, m_1 \\ g_{j+m_2} = \theta_p + \theta_c - \theta(y_j) \geq 0 \end{cases} \quad (5)$$

where

$$y_j = y_c + \frac{j-1}{m_2} (1 - y_c)$$

Equations (1)-(5) are the basic equations for the problem discussed in this article. We shall now reduce it to the standard form of a mathematical programming problem.

3. Standard Equation of a Mathematical Programming Problem

We assume that the surface equation of the minimum-heating configuration can be expressed in a series

$$x = \begin{cases} R_0 - \sqrt{R_0^2 - (y - y_1)^2} & 0 \leq y \leq y_1 \\ \left(\frac{2}{\tau} - \text{ctg} \theta_c \right) + y \text{ctg} \theta_c + \sum_{i=1}^{m-1} A_i \cos \left[\frac{2i-1}{2} \frac{\pi(y-y_c)}{1-y_c} \right] & y_c \leq y \leq 1 \end{cases} \quad (6)$$

where y_1 , y_c , θ_c , A_i are constants to be determined. It is clear that the boundary condition (2) is identically satisfied. When A_i ($i=1, 2, 3, \dots, m-1$) are all zero, the configuration is a flat-nose cone with a half cone angle equal to θ_c . Since the smoothing condition (4) is a very simple equality constraint, two supplemental equations can be derived from it to eliminate two unknown constants, i.e.,

$$y_1 = \frac{-\frac{2}{\tau} - \text{ctg} \theta_c + \sum_{i=1}^{m-1} A_i}{(1 - \sin \theta_c) - (1 + \gamma \cos \theta_c) \text{ctg} \theta_c} \quad (7)$$

$$y_c = y_1 (1 + \gamma \text{csc} \theta_c)$$

By substituting equation (6) into equations (1), (3) and (5), and taking into consideration equation (7), one can obtain the standard equation of a mathematical programming problem.

$$F = F(\theta_c, A_1, A_2, \dots, A_{m-1})$$

$$g_i(\theta_c, A_1, A_2, \dots, A_{m-1}) \geq 0, \quad i = 1, 2, \dots, m_1 + m_2 + m_3 \quad (8)$$

Therefore, for a given reentry weight and fineness ratio, the problem of a minimum-heating configuration which satisfies specified longitudinal stability conditions is reduced to a problem of solving for a design vector D^m ($\theta_c, A_1, \dots, A_{m-1}$) which minimizes the objective function F and satisfies a set of design constraint conditions

$$g_i(D^m) \geq 0, \quad i = 1, 2, \dots, m_1 + m_2 + m_3$$

III. Calculation of Surface Pressure Distribution and Aerodynamic Coefficients for a Flat-Nose Body of Revolution

Wind tunnel tests and numerical calculations [2] show that the sonic point is located near the intersection of the flat nose and the body of revolution. Therefore, it seems reasonable to extend the velocity distribution results for zero angle-of-attack (Ref. [12]) to the case of medium angle-of-attack. In other words, we assume that with moderate angle of attack, the sonic line is still located on a circle near the intersection of the flat nose and the body of revolution $y = y_1$. The radial velocity distribution between the actual stagnation point 0^* and the sonic line is given by the distribution law of Ref. [12].

$$\frac{y^*}{y_1} = \lambda \left(\frac{K+1}{4K+2} + \frac{3K+1}{4K+2} \lambda^2 \right)^{\frac{-2K+1}{3K+1}}$$

The distance between the actual stagnation point 0^* and the center of the flat nose O can be determined by wind tunnel tests.

The pressure distribution along the circle connecting the flat nose and the body of revolution is calculated using the P M expansion theory. If the calculated pressure is lower than the pressure at y_1 determined by the modified Newtonian theory, then the latter will be used. The pressure distribution over the rear section of the body of revolution is calculated using the modified Newtonian theory.

Fig. 2 shows the theoretical pressure distribution and the hypersonic wind tunnel test results over a medium range of angle of attack. It can be seen that the theoretical calculations are in good agreement with wind tunnel test results. [13]

The drag coefficient and the center of pressure coefficient can be calculated from the pressure distribution using conventional formulas. The variation of center of pressure coefficient with angle of attack is plotted in Fig. 3; it also shows good agreement between theoretical values and wind tunnel test results. [14]

Figure 2. Surface Pressure Distribution of a Flat-Nose Cone

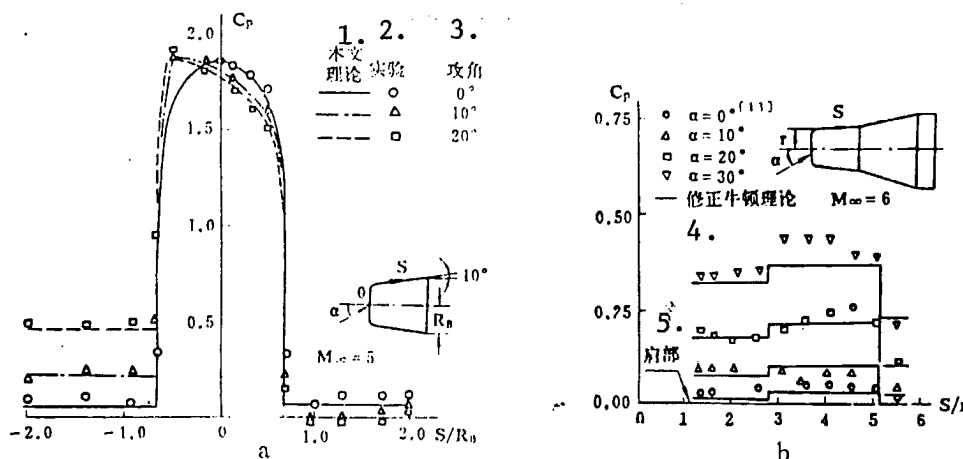

[Key to Figure 2]

Key:

1. theoretical results of this article
2. experimental results
3. angle of attack
4. modified Newtonian theory
5. shoulder

Figure 3. Variation of Center of Pressure Coefficient of a Flat-Nose Cone With Angle of Attack

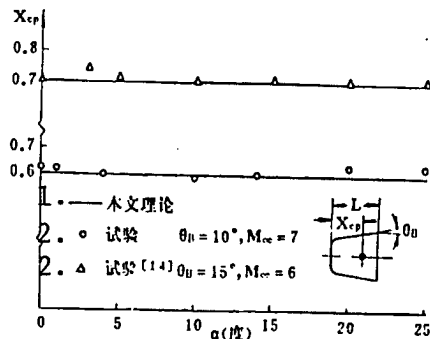

Key:

1. theoretical results of this article
2. experimental results

IV. Optimization Technique

1. The Interior Penalty Function Technique

In this article, the interior penalty function technique is used to solve the mathematical programming problem as indicated in equation (8). In particular, by defining a new objective function

$$F^*(D_m, R_i) = F(D_m) + R_i \sum_{i=1}^{m_1 + 2m_2} \frac{1}{g_i(D_m)}$$

the problem with inequality constraint is converted into an unconstrained problem, which is then solved using the conventional variable scale method [15] for the design vector D_m which minimizes the objective function F^* . By assigning a series of descending values to the penalty parameters R_i , the design vector will approach the minimum-value solution of the original problem with inequality constraints. The following convergence criterion may be used:

$$\left| \frac{F_j^* - F_{j-1}^*}{F_j^*} \right| \leq \delta$$

In the variable scale method, the following formula is used for correcting the matrix H:

$$H_{i+1} = H_i + \frac{\Delta D_i \Delta D_i^T}{(\Delta D_i, \Delta G_i)} - \frac{H_i \Delta G_i (H_i \Delta G_i)^T}{(\Delta G_i, H_i \Delta G_i)}$$

where

$$\Delta D_i = D_{i+1} - D_i, \quad G_i = G_{i+1} - G_i$$

In order to ensure the positive definiteness of the second order matrix and to improve the efficiency of the variable scale method, the matrix H is allowed to be re-initialized during each iteration cycle. In the one-dimensional search process, a quadratic interpolation formula is used to find the steepest-descent step size α^* . If the first interpolation cannot meet the accuracy requirement of the search process, the interpolation process may be repeated.

Since this article uses the interior penalty function technique to solve a constrained optimization problem, it is necessary to ensure that the constraint conditions are not violated during the one-dimensional search process or during gradient calculation of the objective function.

2. Selection of Feasible Initial Design Vector

For configurations with a given fineness ratio and the same aerodynamic drag, the flat-nose body of revolution is one with the smallest reentry heating [4]. Therefore, we may choose a flat-nose cone whose center of pressure is slightly greater than the specified value X_{cpp} as the initial configuration. If all the candidate flat-nose cones have X_{cpp} centers of pressure smaller than the specified value, then one must choose an initial value based on experience with test calculations so that the constraint conditions are not violated.

Fig. 4 shows the logic diagram of the computational procedure.

[see Fig. 4, next page]

Figure 4. Logic Diagram of Computational Procedure

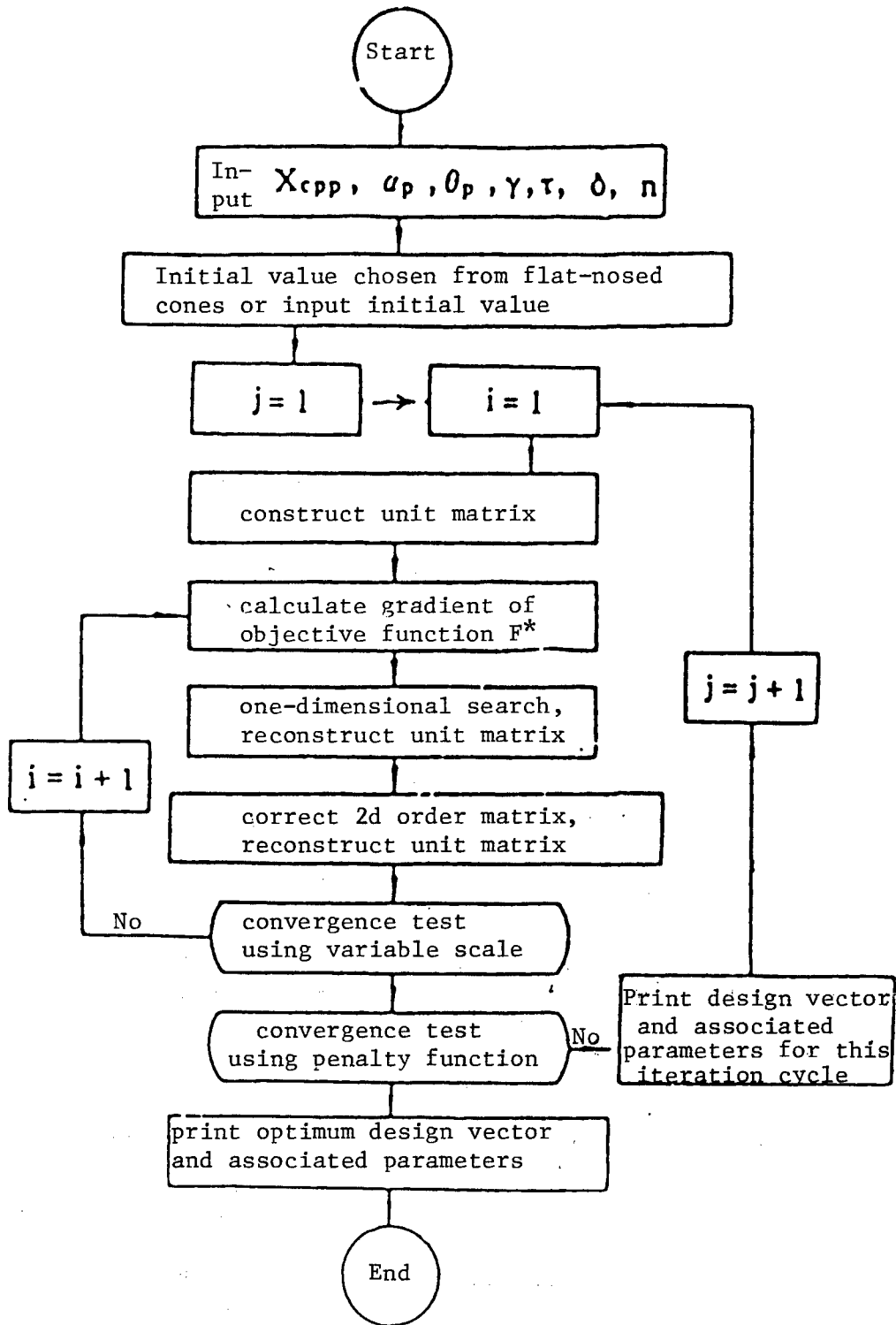

V. Numerical Results

Three numerical examples have been calculated using the procedure shown in Fig. 4. The parameters used in the calculation are shown in Table 1 and the calculated results are shown in Fig. 5.

Table 1. Parameters and Initial Values

K	ω	τ	γ	α_p	θ_p	X_{cpp}	δ
1.2	1.0	1.0	0.1	15°	15°	1.6, 1.7, 1.8	0.0001

Figure 5. Aerodynamic Configurations Corresponding to Minimum Reentry Heating

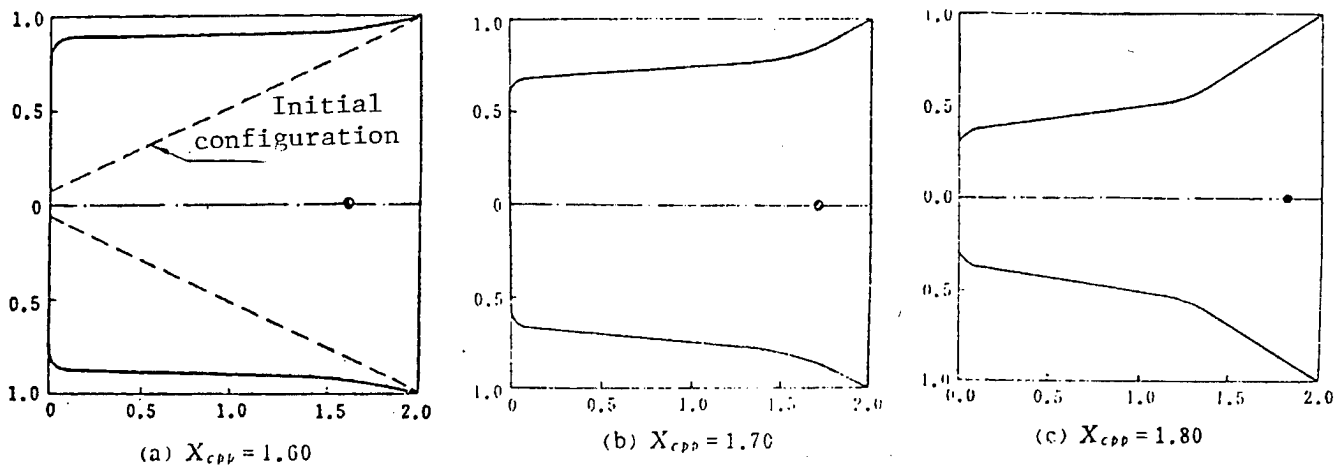

Fig. 5(a) shows the minimum reentry heating configuration which has a center of pressure coefficient greater than 1.60 (using the base radius as the reference length); the broken lines represent the flat-nose cone which corresponds to the initial values of the parameters $\theta_c, A_1, A_2, \dots, A_{m-1}$. Fig. 5(b) and Fig. 5(c) show the minimum-heating configurations which have center of pressure coefficients 1.70 and 1.80, respectively. For the given value of fineness ratio, there are no flat-nose cones with center of pressure coefficient greater than 1.70; therefore, the initial parameter values for these two examples are chosen based on experience.

It can be seen from Fig. 5 that for a given weight and fineness ratio, the minimum-heating configuration whose center of pressure coefficient is greater than the specified value X_{cpp} within the angle of attack range α_p is approximately a flat-nose double cone; the magnitude of the aft cone angle is related to the allowable maximum flow deflection angle θ , the magnitude of the forward cone angle and the ratio between the lengths of the fore and aft cones are related to the specified center of pressure coefficients X_{cpp} . The minimum-heating configuration corresponding to laminar flow reentry differs very little from the case of turbulent flow reentry because the

ultimate geometric dimensions of the configuration are primarily controlled by the center of pressure coefficient X_{cpp} .

Because of the contribution of the aft cone to longitudinal stability, it is possible to increase vehicle drag and reduce the ballistic coefficient $M/C_D A$ by reducing the forward cone angle and increasing the flat-nose height (i.e., increasing the bluntness ratio) while satisfying the stability requirements. This design can achieve the goal of minimizing the total reentry heating and also reducing the weight of the insulation layer. The total reentry heating calculated in this article for an approximate flat-nose double cone with a center of pressure coefficient of 1.6 is approximately 62 percent (laminar flow) or 80 percent (turbulent flow) smaller than that of a flat-nose cone with identical center of pressure coefficient.

It should be pointed out that this article did not consider the effect of viscous disturbance of the aft cone. If the flow deflection angle θ_p is limited to a sufficiently small value, the effect of viscous disturbance can be neglected. Of course, even if viscous disturbance and its effect on aerodynamic heating are taken into account, the problem in principle can still be solved without much difficulty.

Since the geometric shape of the vehicle is subject to large fluctuations during the optimization process, it is impractical to use a sophisticated method for calculating the pressure distribution over the aft body; hence, the classical modified Newtonian theory is used in this article. Despite the lack of accuracy of this method in some cases, it is quite general and is considered adequate for the optimization examples presented in this article.

VI. Conclusions

1. Optimization design of reentry vehicle configuration for minimum aerodynamic heating can be carried out using the interior penalty function technique and the variable scale technique.
2. For a given reentry weight and fineness ratio, the minimum-heating configuration with a specified center of pressure coefficient is approximately a flat-nose double cone.

Notations

A, A_i reference area, design vector element

C_D drag coefficient

C_p surface pressure coefficient $C_p = \frac{P_e - P_\infty}{\frac{1}{2} \rho_\infty V_\infty^2}$

F, F^* objective functions

G	gradient of objective function	$G = \nabla F^*$
ξ_1	constraint function	
H	enthalpy, second order symmetric matrix	
K	ratio of specific heats of air	
L	total length of vehicle	
M	mass of vehicle, Mach number	
n	index number of laminar flow or turbulent flow	
P, \bar{P}	surface pressure, surface pressure coefficient	$\bar{P} = P_e / P_o$
q, Q	heat flux, total heating during reentry	
R_o, R_B	angular radius of small circle, base radius	
γ	ratio between angular radius of small circle and flat-nose height	
		$\gamma = R_o / Y$
R, Re_x	penalty parameter, Reynolds Number	$Re_x = \frac{\rho_e u_e x}{\mu_e}$
S, s	surface arc length	$s = S / R_B$
u, \bar{u}	tangential velocity	$\bar{u} = u / \sqrt{2 H_o}$
V	flight speed	
X, x	vehicle longitudinal coordinate	$x = X / R_B$
X_{cp}, x_{cp}	longitudinal coordinate of center of pressure	
	center of pressure coefficient	$x_{cp} = X_{cp} / R_B$
Y, y	vehicle lateral coordinate	$y = Y / R_B$
α	angle of attack, step size for one-dimensional search	
δ	computation accuracy	
θ	surface inclination angle, reentry angle	
λ	critical velocity ratio	
$\mu, \bar{\mu}$	coefficient of viscosity of air,	=
$\rho, \bar{\rho}$	air density	

τ	fineness ratio
ϕ	circumferential meridian angle
ω	index of viscosity law
Δ	distance between actual stagnation point and center of flat nose

Superscripts

T	vector transposition
---	----------------------

Subscripts

0	stagnation point
1	tangent between rounded corner and flat nose
∞	free stream
c	tangent between rounded corner and main body
e	outer edge of boundary layer
E	initial condition of atmospheric reentry
L	laminar boundary layer
P	specified design value
T	turbulent boundary layer

3012

CSO: 4008/196

LIFE SCIENCES

HEALTH MINISTER WRITES JIANKANG BAO ARTICLE

OW051305 Beijing XINHUA in English 1141 GMT 5 Apr 84

[Text] Beijing, 5 Apr (XINHUA)--Cui Yueli, China's minister of public health gives his enthusiastic support to the theme for 1984 world health day "Children's Health--Tomorrow's Wealth" in an article in today's HEALTH NEWS.

World health day, April 7, is sponsored by the World Health Organization (WHO). A new theme is designated every year. The theme for 1983 was "health for all, the countdown has begun."

In his article entitled "Children's Health, The Future of the Motherland," Minister Cui gives an introduction to children's health care in China.

A complete network of maternal and child care has been set up in China's urban and rural areas, the minister says. Now, China has 24 children's hospitals and 18 institutes for child health care, in addition to 2,827 maternal and child care hospitals and centers. The country has 31,000 pediatricians and 92,000 hospital beds for children.

Due to the free preventive inoculations, most infectious diseases which affect children, have been brought under control. China's infant mortality rate has dropped from 200 per thousand before the founding of the People's Republic in 1949 to 34.68 per thousand in 1981.

Child health care services are stressed especially in the rural areas. They include teaching of scientific child care methods, regular health checkups and the keeping of systematic records for all children under the age of seven years. The government has also set up a national group for coordinating the work on prevention and treatment of rickets.

The minister points out that in order to do child care work well. China has called upon the whole society to be concerned. More pediatricians and paramedics are being trained. The mass media, especially TV and radio are used to teach the people scientific prenatal and child care methods.

HEALTH NEWS today also devoted a special column to the occasion. Articles printed included those written by Dr. H. Mahler, director-general of WHO; Dr. Hiroshi Nakajima, regional director of WHO for the western Pacific; Michel Manciaux, a French professor of public health and social medicine; and Doctor Mark A. Belsey, chief of the maternal and child health unit of WHO.

SCIENTISTS AND SCIENTIFIC ORGANIZATIONS

ROCKET DESIGNER'S CONTRIBUTIONS TO SPACE PROGRAM DESCRIBED

Beijing GUANGMING RIBAO in Chinese 8 Mar 84 p 2

[Article by GONGREN RIBAO correspondents Yan Zhiping [0917 1807 1627] and Guo Ping [6753 5493] and GUANGMING RIBAO correspondent Liu Jingzhi [0491 2417 2535]: "A Jump from an Ordinary Women Worker to a Specialist in Space Technology--Portrait of Wang Zhiren [3769 0037 0117], Deputy Chief Designer of Booster Rockets"]

[Text] In the evening of 29 January 1984, a thunderous, smoke-shrouded, milky white rocket spewing red flames and packing an earth-shaking force lifted off the ground, carrying our experimental telecommunications satellite into space.

Soon, the rocket disappeared in the sky. But a peasant-like, middle-aged woman remained there for a long time, stretching her neck and focusing her sparkling eyes on the blue sky and space. With a dark and weather-beaten complexion, she looked like a country bumpkin rather than an expert. She was Wang Zhiren, an outstanding woman in our scientific circles.

"Her heart was warmer than July temperature!"

Wang Zhiren gazed at the blue sky for a long time, with her thoughts scintillating like shining spots on the fluorescent screen. It was a summer evening in 1951, when Premier Zhou held a farewell party for students going abroad in the brilliantly illuminated banquet hall of the Beijing Restaurant.

"I wish you all success in study, in acquiring the scientific knowledge and skills essential for the building of a new China." Upon hearing Premier Zhou's admonition, Wang Zhiren, one of students in the first group going to the Soviet Union, was as excited as the July barometer. In her heart, she vowed to do something.

Nearly 7 years later, she received an "A+" achievement report as a contribution to the motherland. But she also knew that this did not mean that she had fulfilled the important task assigned by the motherland.

She still clearly remembers the exciting occasion of 17 November 1957, when Chairman Mao, Song Qingling, Deng Xiaoping, Peng Dehuai and other party and state leaders gathered at the auditorium of Moscow University to see the Chinese students. On that day, Chairman Mao delivered a famous speech, stating: "The world is yours, hinging its hopes on you." Later on, he pointed out on another special

occasion: "We must also send aloft manmade earth satellites." By that time, she thought that the attempts made by our party shortly after the founding of the People's Republic of China to produce rockets and satellites and to send students abroad for this purpose were indeed far-reaching.

"This child goes crazy."

Like many others, Wang Zhiren looked forward to that day with a single-minded devotion to study, research and work. The wrinkles created by years of hard work symbolize her deep love for the cause of the motherland, and testify to her hard struggle to transform herself from an ordinary woman worker into a scientist.

During the frigid winter of 1945, the liberated Shanxi-Chahar-Hebei border area was brimming with joy. By then, the border organization department saw a rural girl excitedly come in and turn over a letter of recommendation and introduce herself by saying: "I am Wang Zhiren, a Communist Party member, 16 years old, looking for a job." Seeing that shy but brave girl, a comrade at the organization department immediately introduced her to the industry department. Coincidentally, it was the day when the border area chemical plant director came to the department for a meeting. The new worker was then directly turned over to him.

"The chemical plant produces dynamite, detonators and artillery shells...", the director tried to test her out.

"Nothing can scare me" the new worker gave the director an answer as loud as a bombshell before the latter could finish his sentence. From then on, that orphaned girl joined the glorious rank of the working class, and the term "nothing can scare me" became a living motto for her until she became a middle-aged woman.

The ordnance plant looked shabby. All it had were two jars that could be latched into a reaction device and sheepskin bags that were used as air blowers. Wang Zhiren joined the sulfuric acid shift of just over 10 workers whose cotton-padded uniforms became threadbare as a result of erosion by sulfuric acid. One day, carbon bisulphide choked her throat until it bled. The working conditions there were miserable. But as a former member of the children's corps, that little girl had no problem surviving hardships of that kind.

One day when comrades from the Yanan Academy of Sciences arrived at the plant to offer workers there courses in chemistry and mathematics, Wang Zhiren did not hesitate to register for enrollment in such courses. She considered it necessary to study culture, which was essential to the building of a new China after the war was over, and important for everyone to become a master of his or her own country. After a day's work, she often felt too tired to do anything else. However, once she entered the classroom, her feeling of fatigue was immediately gone. She often did mathematics and other homework in bed until midnight. As soon as the day broke, she would go outside reciting what she had learned earlier. Sometimes when she was half through with a meal, she gazed at the ceiling listlessly with the bowl in her hands. "That child has gone crazy" teachers often said of her with tender care.

When Wang Zhiren studied chemistry, the Shanxi-Chahar-Hebei border-area industry school served notice that students were encouraged to take examinations for the

course in chemistry. Teachers all encouraged her to register for such examinations. Thanks to the 2 years of efforts, she passed the examinations. She also never failed to live up to the expectations of her teachers, who wanted her to be among the best and most successful in academic studies. From then on, she spared no effort to acquire a knowledge which seems as vast as the oceans, and devoted her energy to scaling endless peaks of science. Shortly after she graduated from the Hebei Institute of Technology Chemistry Department, she was admitted to the Aeronautics Department according to the decision made by her organization. In 1951, she was selected and sent to the Soviet Union for study, thus opening another prospect for her to explore the universe of space science.

"It Appears That She Wants To Break Away From The Earth's Gravitation."

During the 7 years of study away from home, she was simply too busy to be able to enjoy any points of tourist interest around Moscow. She also showed little interest in the vast skating rinks in front of her dormitory which usually attracted many people. Many Soviet students tried to invite her to dance without success. In order to get the motherland's space program off the ground as early as possible, instead of wasting time on recreation and carefree activities, she devoted full energy to acquiring knowledge and skills, as if she were a rocket trying to break away from the earth's gravitation.

Among the Chinese students, she was the only one married. Before her departure from China, she told her husband, a student of the Beijing Industry College: "I consider academic achievements more important than anything else. I vow not to return to see you here, if I fail to get straight 'A+.' With an insatiable desire for knowledge, she studied for the purpose of rehabilitating the motherland. She spent almost every Sunday in the laboratory. In order to read as much material as possible, she often entered the heavily guarded room, bringing with her only a piece of bread as lunch.

During the 4th year of putting her newly acquired knowledge into practice, her original destination was a rocket-launching pad in the Urals. What a good opportunity indeed! Incidentally, because the plane could not take off, the rocket test flight was rescheduled at an ordinary airport near Moscow. A devoted person will never fail to reach the goal of study, however poor the conditions. When she was working on the design on the Carpathians during the graduation year, the living conditions were so miserable that she was forced to eat black bread every meal time and wash her body without soap. However, she said of this with a sense of humor: "We are on a study tour of this foreign country. We are not sightseers. Nothing is worse than that in the liberated area."

As a result of constant efforts over the years, she became a brilliant student in the eyes of other classmates. Both teachers and students would hold up their thumbs, whenever her spirit in study and her academic achievements were mentioned.

"After throwing away the walking stick, one can run faster than ever!"

Shortly after returning to the motherland in 1958, Wang Zhiren participated in the space program when it remained in its initial stage. By then, we remained in the stage of copying Soviet rockets. In other words, the Chinese could only

copy mechanically, and could not offer any opinions, even if others were wrong. Then a desire for making China strong was burning in her heart.

In 1960, the Soviet government scrapped agreements that called for helping China conduct research on the production of rockets and pulled its experts out of China. This action by the Soviet leadership further prodded Wang Zhiren and her colleagues into steeling their determination to display the spirit of self-reliance. Solely relying on walking sticks to develop the space program for the motherland would not work and would earn us a name of perpetual backwardness. Wang Zhiren and her colleagues then commonly vowed to "send aloft rockets designed and manufactured by China." China was a home for rockets. Despite this, the research on rockets made no progress since the Song Dynasty, for many reasons. Needless to say, it is very difficult to develop space technology in China. The generator is the heart of a rocket. By that time, among those responsible for the manufacturing of rockets were four college graduates fresh from school, handicapped by a lack of experience and blueprints and by run-down equipment. In short, they must start from scratch. However, under the leadership of the party, with the support of the workers and the solid foundation of knowledge they acquired in school, every obstacle could be removed. Nie Rongzhen often put forward specific demands in his capacity as chairman of the National Defense Scientific and Technological Commission. At every meeting, workers never hesitated to volunteer their advice and seek solutions. Sometimes, components produced according to blueprints drawn by designers did not fit at all. When that occurred, workers would conduct experiments repeatedly, until they could produce a prototype which could be used as a pattern for making blueprints. Rocket engineers often spent hours in equipment rooms and by the side of machinery, helping workers wash spare parts and passing tools around. Working in complete harmony, they spent days and nights laboring hard. In a matter of a mere 3 years, they produced rocket generators with blueprints, technological processes and materials designed and manufactured by China.

From the beginning, smooth sailing was not expected of such things. Problems developed immediately during the first trial run of the generator. In the final analysis, what was the matter? As a responsible person of the research and production group, Wang Zhiren was so desperate that she could neither eat nor sleep. She had no alternative but to spend days and nights working at the experimental station. In doing so, she forgot to take care of her sick baby in the cradle at home. Work also forced her to cut off the breast feeding for the child when he was only 1 month old. From then on, he was fed with only porridge mixed with soy sauce. Nearly 6 months later, he contracted soft bone disease and frequently suffered from convulsions, due to undernourishment. Later, the infant was so weak that he contracted pneumonia and measles. One night, Wang Zhiren felt very sad when holding her baby in high fever in her chest. By that time, her sister-in-law, who usually took care of her baby and supported her work, blamed her by saying: "You are in no way acting like a mother!"

True, every mother in the world loves her children. It was especially true of Wang Zhiren who gave birth to her first baby after 13 years of marriage. But Wang Zhiren quietly said to herself: "In order to make our rockets lift off the ground as early as possible, I am sorry, baby, that you have to put up with this." As soon as the night gave way to the day, she usually put her baby back in bed again and then joined other comrades-in-arms on a bus bound for the experimental station,

however tired she felt. After repeated analysis and investigations, she finally identified the cause of the problem. Based on the opinions given by other comrades, Wang Zhiren adopted 30 revised proposals, and carried out more than 100 tests, which led her to overcome the problem once and for all.

Shortly after this was done, our first booster rocket lifted off the ground and went into orbit. This meant that by relying on their own efforts, the Chinese scientists, technicians and workers succeeded in opening the door to the space.

"We will soon have new types of rockets."

Shortly after the 10-year turmoil began, Wang Zhiren was transferred away from the main line of duty. But she neither lost her composure nor complained. In order to carry out that important task, she quietly swallowed that humiliation so that she could devote her full attention to the rockets. By then, although she was not responsible for administrative work, she still persisted in carrying out the technical work, just as she did in the past. In the face of numerous difficulties, she kept in close touch with the masses and the designers on the front-line of production more frequently than ever. By that time, because a component related to the new type of rockets failed to pass the desired tests, she had no alternative but to replace it with non-metallic materials. Because their production plant could be reached only by train, Wang Zhiren and other technicians had to leave their station in the evening so that they could arrive there in the middle of the night and return and start the work again early in the morning. Under the disruptive influence of the "gang of four," anarchism prevailed, and some work was unattended. In order to insure the continuation of scientific research, Wang Zhiren had to take up many concurrent jobs at the same time, including the distribution of uniforms for workers. As a result of efforts by her and other comrades, a series of serious problems were resolved in the shortest possible time to bring the research work to a successful conclusion. In the same year when the work of producing the new type of rockets was basically accomplished, Wang Zhiren received a notice ordering her to report to a cadre school. Before her departure, she quietly arrived in the workshop, walking toward where the rocket ready to fire was located and touching the rocket body from head to tail again and again with affection until tears blurred the eyesights of that strong-minded lady.

In 1970, a new type of booster rocket carried our first manmade earth satellite-- "The East Is Red-No 1"--into the space. When "The East Is Red" strains reverberated across space, and when this scientific feat was celebrated by the people throughout the motherland, who would imagine that Wang Zhiren and other experts devoted to bringing that rocket into orbit were working in the vast fields. They were members of the first group targeted for reform through labor at the "7 May" cadre school and were sent there 2 months after completing the last process of rocket production. "The East Is Red" music brought joy to smiling plow bearers in the central plains, who turned on their radios again and again and conveyed congratulations to the motherland from the bottom of their hearts. To them, fame, social status and salary meant nothing, and what really mattered in life was how much one had contributed to the motherland and the people and in what ways. They were satisfied as long as the world knew through the music from space that the satellite was sent aloft by the Chinese people themselves. In the

evening of the same day, a discussion meeting was held for them to voice their views on this subject. Wang Zhiren said: "We will soon send aloft new types of rockets." While confidently looking forward to returning to her original post, she firmly believed in his possibility.

"One New Goal After Another Should Be Reached."

Those years in memory eventually gave way to the spring of science. In 1978, Wang Zhiren was appointed deputy chief designer of the new-type booster rockets following her return to her original post.

By then, some people maintained that "there will be difficulties in producing the new-type rockets because the time is pressing, our equipment is poor and our industrial foundation is weak." Confronted by the mood of fearing difficulties, Wang Zhiren and the majority of other comrades stated: "Despite the fact that some time has been wasted due to the obstruction and sabotage by the 'gang of four,' the enforcement of the task assigned by the state cannot be postponed. Whether or not this task can be accomplished is a matter of concern not only to our national reputation and prestige but also to our military power. We can neither wait nor rely on somebody else. We must rely on our own efforts. Only action will bring us success."

Despite numerous difficulties in producing the new-type booster rockets, they were never taken aback. Ball bearings were indeed a long-standing difficult problem. In solving this problem, some people suggested that a ball bearing model be imported from abroad so that we could have something to refer to. Following consultations among some departments, the answer was "no." This decision gave all concerned a profound education. A new type of ball bearing was finally designed and produced in a spirit of self-reliance and close cooperation. While blazing a path to the future, we may encounter brambles every step of the way, and we must stand ready to resolve one contradiction after another and one new problem after another. Wang Zhiren was well aware of her responsibility. She must read technical material, help the director of the institute broadly organize technical discussion meetings and establish groups to overcome technical problems and remove one obstacle after another to success.

After seeing one rocket after another lift off the ground and one satellite after another cruise in the space, this female expert of ours is now in her fifties. She still continues to extend her working hours. As a matter of fact, she almost forgets when she should go home and relax. She thinks of work when she is taking a meal and before falling asleep. It can be said that her mind has been preoccupied with rockets. Until now, she can completely and clearly understand every part of a rocket, and every step in its production process, and know how to solve problems that may arise in the process. She even can anticipate the nature of problems that need to be solved. Wearing simple dress, Wang Zhiren often eats noodle, hardened sesame seed cake and cold steamed bread and drinks plain boiled water. In the end, she broke down from constant overwork and became clearly exhausted and emaciated.

One day, before she proceeded with another new rocket test, her organization issued the following order to her following a check on her latest physical

condition: "You must take leave immediately, and should no longer go to the base."

"I have been looking forward to this day for so long. How can you expect me to do that?" She argued and pleaded with her case.

Long after the experimental satellite was successfully launched, Wang Zhiren remained around its launching pad, gazing at the stars in the night sky. What was she up to? She said: "We will soon conduct another new experiment." Of course, she still must overcome one obstacle after another and scale one new peak after another. From an ordinary female worker to a specialist in space technology, Wang Zhiren has never stopped scaling the peaks of science for the modernization of the motherland.

9574

CSO: 4008/194

Communications

AUTHOR: XU Mengxia [1776 1322 0204]

ORG: Beijing University

TITLE: "Switch-Adaptive Intraframe DPCM Picture Coding"

SOURCE: Beijing TONGXIN XUEBAO [JOURNAL OF CHINA INSTITUTE OF COMMUNICATIONS]
in Chinese No 1, 1984 pp 7-18

TEXT OF ENGLISH ABSTRACT: The switch-adaptive intraframe DPCM picture coding proposed in this paper is: (1) Every present pel (picture element) is determined as nonactive or active from an activity value of its previous pel, and one of two adaptive predictors is switched on. (2) According to the minimum-difference direction of the previous pel with its neighboring pels, one of four sets of prediction coefficients is switched on for the prediction of the present pel. (3) Two non-linear quantizers are designed from subjective tests for the two adaptive predictors, corresponding to nonactive and active pels.

Calculations with four test pictures show that the prediction errors (without quantizer) of the proposed switch-adaptive predictor have its histogram more concentrated in the neighborhood of $e=0$ and a decrease of entropy values (0.2 bit/pel on the average) in comparison with 2-dim DPCM predictors with constant coefficients.

Subjective tests are simulated with three sets of sequence pictures of the sampling frequency 10 MHz. Masking functions are measured to design non-linear quantizers with a minimum number of levels criteria. The minimum number of quantization levels needed for the reconstructed pictures of the proposed scheme which show barely visible differences in comparison with the original sequence pictures are smaller than those in published works.

The results of this paper can be used for DPCM coding of PAL luminance signals with the sampling frequency 10 MHz. The total bit rate for the digital transmission of PAL broadcasting TV signals (including chrominance signals, stereo sound signals and error correcting code) is fit to PCM third hierarchy (34.368 Mbits/s).

AUTHOR: BAO Ziwei [0545 4793 5633]

ORG: Research Institute of Acoustics, Nanjing University

TITLE: "The Statistical Properties of Conversational Speech Level of Chinese People and a Check of Speech Level Monitoring Systems"

SOURCE: Beijing TONGXIN XUEBAO [JOURNAL OF CHINA INSTITUTE OF COMMUNICATIONS] in Chinese No 1, 1984 pp 82-87

TEXT OF ENGLISH ABSTRACT: This paper offers some data concerning conversational speech levels of Chinese, such as (1) long term mean RMS values, (2) RMS values of four pitch tones of Chinese words, (3) peak values, and (4) RMS value in the environment of different noise levels.

Since conversational speech speed varies with time and its level fluctuates within a wide range, the dynamic responses of the monitor systems (VU meter, Sound Level Meter and Level Recorder) have been tested in order to find a more suitable system for statistical measurement. The results suggest that the Level Recorder is preferable for this purpose.

Based on the measuring of more than 5000 syllables, the statistical distribution of long term speech levels has been determined. In addition, the speech powers were calculated from Fletcher's so-called "Talker's level" formula rather than from spherical waves because the scattering effect of the head and torso must be taken into account.

9717

CSO: 4009/66

AUTHOR: ZHOU Ji [0719 0679]

ORG: Shijiazhuang Communication Laboratories

TITLE: "Design and Performance Analysis of Synchronization of TFP Digital Troposcatter Modem"

SOURCE: Beijing TONGXIN XUEBAO [JOURNAL OF CHINA INSTITUTE OF COMMUNICATIONS]
in Chinese No 1, 1984 pp 61-67

TEXT OF ENGLISH ABSTRACT: This paper presents a scheme of synchronization of middle rate time-frequency-phase (TFP) digital troposcatter modem. The characteristic of this scheme is that synchronizing information adheres to digital signal modulation in the transmitting terminal and envelope detection and narrow-band filter are used to extract synchronizing signal in the receiving terminal. Equipment is simple and reliable and, in addition, it has excellent antinoise, antifading capabilities. Experimental results are in good agreement with those from direct calculations.

Radiology

AUTHOR: CHEN Zhiheng
et al.

ORG: None

TITLE: "Improved Rapid Method for Measurement of Radon Daughter Concentrations and Working Level"

SOURCE: Beijing ZHONGHUA FANGSHE YIXUE YU FANGHU ZAZHI [CHINESE JOURNAL OF RADIOLOGICAL MEDICINE AND PROTECTION] in Chinese No 6, 25 Dec 83 pp 17-21, 73

TEXT OF ENGLISH ABSTRACT: This paper describes a simplified rapid method for measuring RaA, RaB and RaC concentrations and WL values by using the total α counts on filters during the time intervals from 0.5 to 5 min and 5.5 to 10 min after sampling. A systematic and clear calculating equation is given. The results of this method are compared with those of the Thomas and Markov methods; the modified method displays higher accuracy.

9717

CSO: 4009/47

END