

REPORT DOCUMENTATION PAGE

Form Approved
OMB No. 0704-0188

Public reporting burden for this collection of information is estimated to average 1 hour per response, including the time for reviewing instructions, searching existing data sources, gathering and maintaining the data needed, and completing and reviewing the collection of information. Send comments regarding this burden estimate or any other aspect of this collection of information, including suggestions for reducing this burden, to Washington Headquarters Services, Directorate for Information Operations and Reports, 1215 Jefferson Davis Highway, Suite 1204, Arlington, VA 22202-4302, and to the Office of Management and Budget, Paperwork Reduction Project (0704-0188), Washington, DC 20503.

1. AGENCY USE ONLY (Leave blank)	2. REPORT DATE 9-9-98	3. REPORT TYPE AND DATES COVERED Final Technical: 6/15/95 to 6/14/98	
4. TITLE AND SUBTITLE Variable Store Flutter Suppression (AASERT '95)		5. FUNDING NUMBERS F49620-95-0426	
6. AUTHOR(S) <p style="text-align: center;">Daniel J. Inman</p> <p style="text-align: right; font-weight: bold;">AFRL-SR-BL-TR-98- <i>0686</i></p>			
7. PERFORMING ORGANIZATION NAME(S) AND ADDRESS(ES) Virginia Polytechnic Institute and State University Department of Mechanical Engineering CIMSS, mailcode 0261, 310 New Engineering Building Blacksburg, VA 24061		8. PERFORMING ORGANIZATION REPORT NUMBER	
9. SPONSORING/MONITORING AGENCY NAME(S) AND ADDRESS(ES) AFOSR/NM 110 Duncan Avenue, Suite B115 Bolling AFB, DC 20332-0001		10. SPONSORING/MONITORING AGENCY REPORT NUMBER	
11. SUPPLEMENTARY NOTES			
12a. DISTRIBUTION/AVAILABILITY STATEMENT Unlimited		12b. DISTRIBUTION CODE	
13. ABSTRACT (Maximum 200 words) This report summarizes the entire three years of activity on this AASERT award. The supported student made excellent academic progress and continued to develop a laboratory model of the piezoceramic motor intended for use on actuators for controlling the wing/store flutter problem. An experimental test fixture has been fabricated to simultaneously measure force, acceleration, position and velocity for proper actuator characterization. Several linear and nonlinear mathematical models have been developed and several actuators have been constructed. Various iterations between test results, mechanics predictions and design have led to a final configuration using the "thunder" type configuration for the wafers. The final actuation produces a deflection of 0.254 mm and 1.3 N of blocked force, allowing it to be scaled (force multiplied) to fit the store-induced flutter model.			
14. SUBJECT TERMS actuator dynamics, PZT wafer actuator		16. PRICE CODE 23	
17. SECURITY CLASSIFICATION OF REPORT unclassified	18. SECURITY CLASSIFICATION OF THIS PAGE unclassified	19. SECURITY CLASSIFICATION OF ABSTRACT unclassified	20. LIMITATION OF ABSTRACT unlimited

19981113 053

**AUGMENTATION AWARDS FOR SCIENCE & ENGINEERING RESEARCH TRAINING (AASERT)
REPORTING FORM**

The Department of Defense (DoD) requires certain information to evaluate the effectiveness of the AASERT Program. By accepting this Grant which bestows the AASERT funds, the Grantee agrees to provide 1) a brief (not to exceed one page) narrative technical report of the research training activities of the AASERT-funded student(s) and 2) the information requested below. This information should be provided to the Government's technical point of contact by each annual anniversary of the AASERT award date.

1. Grantee identification data: (R&T and Grant numbers found on Page 1 of Grant)

a. Virginia Polytechnic Institute and State University
University Name

b. F49620-95-1-0426 Grant Number

c. FQ 08671-9501222
R&T Number

d. Daniel J. Inman P.I. Name

e. From: 15 JUN 1995 To: 14 JUN 1998
AASERT Reporting Period

NOTE: Grant to which AASERT award is attached is referred to hereafter as "Parent Agreement".

2. Total funding of the Parent Agreement and the number of full-time equivalent graduate students (FTEGS) supported by the Parent Agreement during the 12-month period prior to the AASERT award date.

a. Funding: \$ 0 (F49620-93-1-0280)

b. Number FTEGS: 0

3. Total funding of the Parent Agreement and the number of FTEGS supported by the Parent Agreement during the current 12-month reporting period.

a. Funding: \$ 0

b. Number FTEGS: 0

4. Total AASERT funding and the number of FTEGS and undergraduate students (UGS) supported by AASERT funds during the current 12-month reporting period.

a. Funding: \$ 47,138

b. Number FTEGS: 2

c. Number UGS: 0

VERIFICATION STATEMENT: I hereby verify that all students supported by the AASERT award are U.S. citizens.

Principal Investigator

9 Sept 98
Date

VARIABLE STORE FLUTTER SUPPRESSION

(ASSERT 95)

Grant Number F49620-95-1-0426

Final Report September 11, 1997

Submitted by

Daniel J. Inman

Center for Intelligent Material Systems and Structures

Department of Mechanical Engineering

310 NEB, Mail Code 0261

Virginia Tech, Blacksburg VA 24061-0219

Phone: 540 231-4709

Fax: 540 231-2903

dinman@vt.edu

This document reports on the progress made on F49620-95-1-0426 for the period from June 4, 1995 to June 14, 1998. The following reports our progress for the duration of this ASSERT award.

Program Objectives:

The objectives for this three year program where a) to design and develop mechanics models for a novel "large stroke" piezoceramic actuator, b) examine the usefulness of this actuator for solving the store induced flutter problem. In particular our goal has been to formulate predictive models that would be useful in the design and commercialization of such actuators.

Status of Effort:

The three years effort has lead the supported student to near completion of his Ph.D. dissertation (Clayton Carter, expected October, 1998) and successfully developed a predictive mechanics model of a linear piezoceramic actuator which is force scalable to meet the needs of a smart rack for store induced flutter suppression.

Accomplishments:

Using the parameters of a wing/store model of an F-16 aircraft carrying a GBU-8 bomb near the mid-span under each wing have been used to determine the angular deflection required by this actuator in order to effect the closed loop control of the wing store system. This translates to the requirement of an actuator with stroke length of about 0.25 mm. Unfortunately the forces required are not so evident. However the actuator design used here is scalable in force by simply adding additional plates (see appendix). This effort has produced a prototype actuator, complete with analytical design and model, based on mechanics principles that accomplishes the stated objectives.

The basic and "novel" idea here is to use the bending direction of a piezoceramic wafer to provide a actuator which can be designed with variable force and deflection characteristics. Such an actuator is illustrated in the appendix and formed the basis of the effort of this research program. The appendix consists of the dissertation proposal of Mr. Carter, the main student supported under this award. This appendix explains the details of the actuator design, results of the mechanics models, force versus voltage curves, deflection curves and predictions.

The accomplishments by year can be summarized as follows. The first year a crude actuator was constructed, modeled with finite elements and tested. From this we learned much about the design and mechanics. In particular our mechanics model predicted that the effective blocking force would be increased if the actuator where to be designed with pinned boundary conditions for the wafer. Thus the second year consisted of deriving new models and building a new actuator and test stand (both successfully completed per last years annual report). The third year has involved the application of what is known as "thunder" technology to our actuator configuration.

A search of literature in piezoceramic devices was performed and it was clear from the literature that the use of so called thunder technology, invented at NASA Langley Research Center, had the potential for increasing the force output of our wafer design by a factor of two. The thunder technology is a manufacturing process which puts the piezoceramic component into a pre-stressed arrangement. The pre-stress effectively adds a spring force to the ceramic and substrate system so that when actuated, the ceramic does not have to overcome as much strain energy for electro-mechanical actuation. The theory, construction and experimental verification of this theory applied combined with our own wafer design formed the focus of the third year of our effort. The final result is that we have produced an actuator, with a predictive mechanics model, that is experimentally verified to produce the desired stroke length and force (0.24 mm at a blocking force of 1.3 N). Further more, these wafer actuators can be scaled to a variety of force and stroke lengths including those required for a smart rack approach to store induce flutter and limit cycle control.

Personnel Supported:

This grant was used to support two graduated students Mr. Eric M. Austin and Mr. Clayton Carter. Mr. Austin was supported for only a short period of time, with Mr. Carter receiving most of the funds.

Publications:

The following publication resulted from work resulting from this effort and completed by the PI and funded student during the period of this project:

Carter, C. and Inman, D. J., "Issues in Piezoceramic Wafer-Plate Actuators", ASME International Congress and Expo, November 20-25, 1998.

Carter, C. and Inman, D. J., "Effects of Boundary Conditions on Piezoceramic Wafer-Plate Actuators", ASME International Congress and Expo, November 20-25, 1998.

Austin, E. M. and Inman, D. J. "Modeling of Sandwich Structures", Proceedings 5th International Symposium on Smart Structures and Materials, March 1998, *Passive Damping and Isolation*, Ed. L. P. Davis, Vol 3327.

The following publications resulted from work tangent to the proposed work and completed by the PI and another student during the period of this project:

Gade, P. V. N., and Inman, D. J., "Active control of store induced flutter in incompressible flow," *AIAA Journal of Aircraft*, Vol. 35, No. 3, 1998, pp. 454-461

Gade, P. V. N., and Inman D. J., "Two-dimensional active wing/store flutter suppression using H-infinity theory," *AIAA Journal of Guidance, Control, and Dynamics*, Vol. 20, No. 5, 1997, pp. 949-955.

Gade, P. V. N., and Inman D. J., "Robust adaptive control of wing/store flutter using self-tuning regulator," *AIAA Journal of Guidance, Control, and Dynamics*, to appear.

Interactions and Transitions:

Presentations: Dr. Inman gave 31 public lectures on smart structures during the three years of this grant on *Smart Structures* as part of the American Society of Mechanical Engineers Distinguished Lecture Series. These lectures included a summary of the work performed under the support of this award. In addition Prof. Inman gave four key note addresses at major international conferences on smart structures related topics in Australia, the United States, the United Kingdom and Italy.

Interactions In addition, Dr. Inman visited Eglin Air Force Base and spent the day with Ben Shirley and Ed Anderson discussing store flutter as summarized in the following:

1) In bay vibration problems of trapeze or internal bay carriage (used to hold munitions) in the F-117. This may be a natural for a smart structures solution. The problem seems to be in the vibroacoustics range. There may also be difficulties with the B-1, B-2 rotatory internal launchers. The F-22 rack design is still being worked on (it might be good to go after armament groups and manufactures to try and get involved in the designs).

2) Rack/pylon/wing interaction. The problems displayed in the video still have not been solved. Rather, the flight envelopes have been reduced so that these flutter and release failures do not occur. Hence there need is still for an active mount system to improve the speeds at which stores may be released.

3) Any store system would have to take 8 g's and 800 knots

Transitions: Mr. Carter's and Dr. Inman's work on actuator characterization is being looked has been looked at by UTRC for possible use in jet engine applications for controlling fuel injection. If this works out, it will form a direct transition of Air Force sponsored work to US industry. This actuator is also under study by Face, International, a US based company that manufactures thunder actuators as well as concrete products.

Inventions and Discoveries

We developed a unique actuator which is still in the fabrication stages for possible use in a rack for store induced flutter reduction.

Honors and Awards:

Prof. Inman was named the Director of Virginia Tech's Center for Intelligent Material Systems and Structures effective August 15, 1997. In addition he was named 1997-2000 ASME Distinguished Lecturer. In December of 1997, Dr. Inman was made a fellow of the American Academy of Mechanics.

Appendix

The following attachment gives slides from the student's dissertation proposal and contains technical detail of his work.

Design, Analysis and Characterization of a Scalable Piezoceramic Actuator

**Clayton R. Carter / Daniel J. Inman
Center for Intelligent Material
Systems and Structures
Virginia Tech**

waterplate

Piezoceramic Actuator Background

Soon after the development of Barium Titanate, development of methods for mechanical amplification of piezoelectric induced strains / forces

- ◆ the piezoceramic stack emerged: thin plates stacked mechanically in series, electrically connected in parallel
- ◆ advantages: amplified displacement with good force output, high efficiency
- ◆ disadvantages: no tensile or shear loads, sensitive to boundary conditions

waterplate

Piezoceramic Actuator Background

Applications of piezoceramics in actuators for structural positioning / control began in ~1960:

- ◆ first patented actuator: William J Toulis, 1966. The actuator was the first of the “flex-tensional” family
- ◆ advantages: overcame some of the loading and boundary condition problems
- ◆ disadvantages: significant parasitic losses / inefficiencies

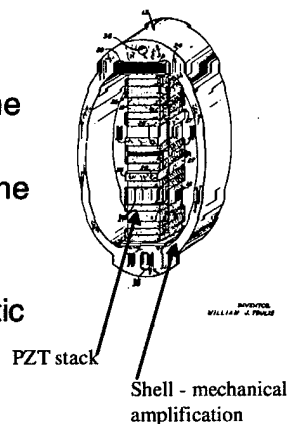

waterplate

Revolution of PZT Actuators

Significant development of actuators realized after Toulis' actuator



Morgan Matrox - unimorph

Application - buzzers, positioning, force transducer

Disadvantages: no connection hardware, you build all electronics, connections, ect

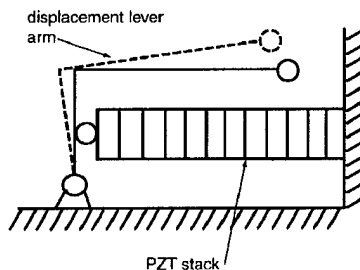

PI Polytech - “Macroblock” actuator concept

Application - micropositioning

waterplate

Inertial Type Induced Strain Actuators

◆ **PCB - Inertial Actuator (model 712 series)**

◆ **PI Polytech - disk translator (model P-288)**

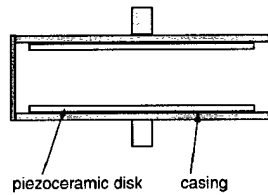
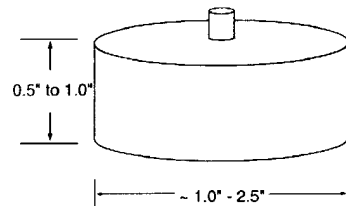

PCB Inertial Actuator - applies forces to a structure by reacting them against an "external" mass

PI Polytech Disk Translator - same concept, boundary conditions are more rigid

Advantages

large stroke, good reaction forces, nice dynamic force-frequency response functions

Disadvantages

not scalable, output force is low compared to dedicated force transducers, bulky, space inefficient, boundary conditions induce parasitic energy losses

walferplate

Flextensional Actuators

Dynamic Structures and Materials LLC.

◆ **Amplified Piezoelectric Actuators (model APA-100)**

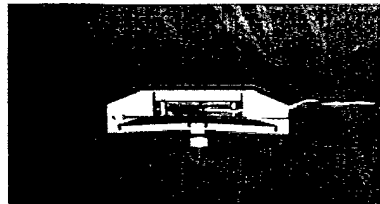

Applications: positioning, force transducer, vibration control

walferplate

New Actuator Concept

What is needed?

- ◆ A scalable actuator (both force and stroke)
- ◆ An actuator with performance independent of the direction of the loading placed on the structure (tensile / compressive)
 - stress state in the PZT does not exceed tensile limits
- ◆ An actuator that does not require pretension, ect in order to operate
- ◆ "off the shelf" components - inexpensive to manufacture, assemble
- ◆ reasonably compact, high energy density
- ◆ efficient (as possible)

waferplate

Induced Strain Bending Type Actuator

Concept of piezoceramic induced strain bending meets most of the basic requirements

Geometry - beam, rectangular plate, circular plate, others?

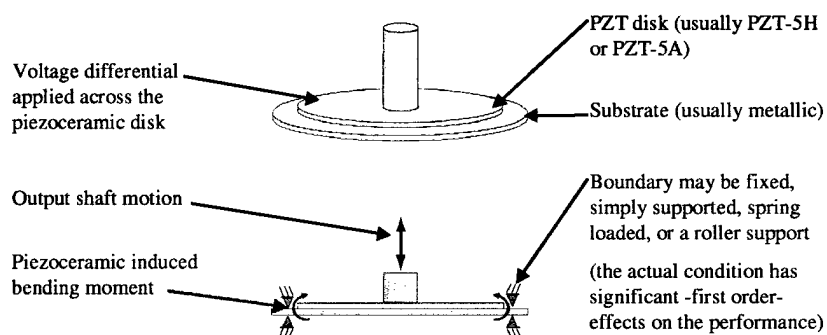

waferplate

First Order Modeling

Treat the plates as “thin” plates within classical plate theory - well developed area (not new work)

- ◆ follow the “Enhanced Pin Force” modeling method
- include the bending stiffness of the PZT

$$D = \frac{1}{3} \sum_{k=1}^n Q_k (z_k^3 - z_{k-1}^3)$$

- ◆ Leads to:

$$D = \frac{E_p^2 t_p^4 + 4 E_p E_s t_p^3 t_s + 6 E_p E_s t_p^2 t_s^2 + 4 E_p E_s t_s^3 t_p + E_s t_s^4}{12 (1 - \nu^2) (E_p t_p + E_s t_s)}$$

- ◆ Model the piezoelectric induced bending moment:

$$M = E_p d_{31} V \left(\frac{t_p}{2} + t_s - \bar{y} \right)$$

- ◆ Classical plate solutions

waferplate

Original Actuator Configuration

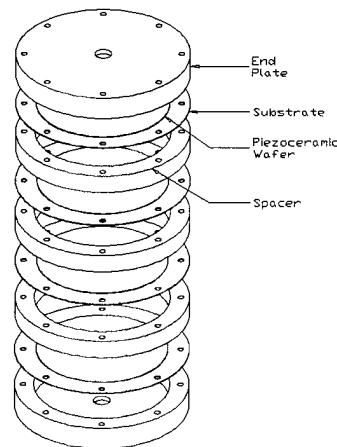

Disadvantages:

- 1- difficult to manufacture and assemble, requires tight manufacturing tolerances
- 2- boundary conditions are difficult to maintain and induced parasitic losses (ss, fixed, guided, ect)
- 3- bulky, heavy and poor use of space

Advantages

- 1- scalable (force - # of plates, stroke - geometry of plates)
- 2- performance is independent of the loading on the actuator (tensile / compressive)

waferplate

Experimental Apparatus

Experimental validation of the actuator is performed in a carefully controlled test-bed

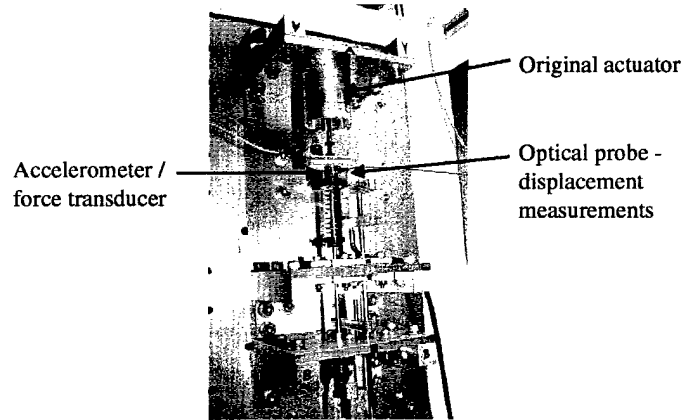

waterplate

Initial Measured Results - Old Design

Stainless Steel substrate displacement plot

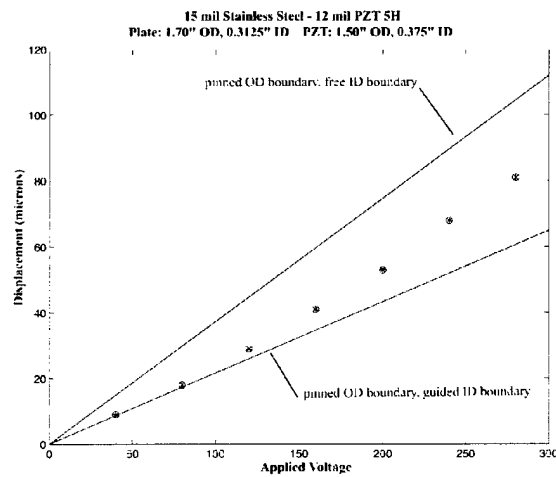

waterplate

Initial Measured Results - Old Design

Brass substrate displacement plot

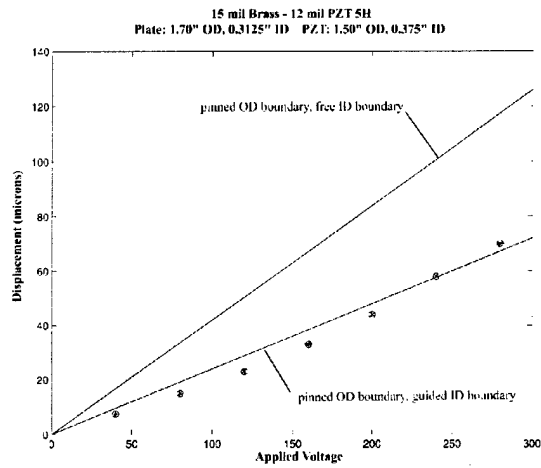

waferplate

Initial Measured Results - Old Design

Stainless Steel substrate displacement plot

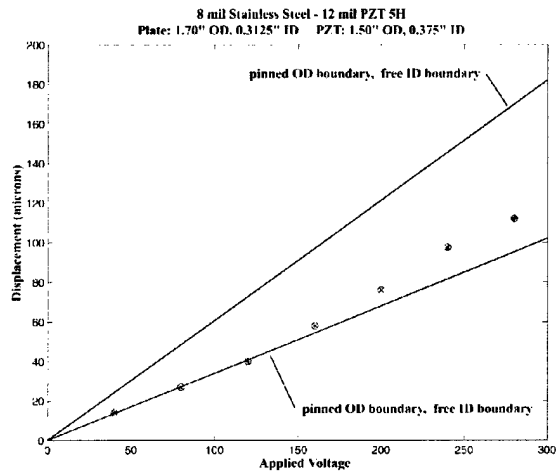

waferplate

Initial Measured Results - Old Design

Brass substrate displacement plot

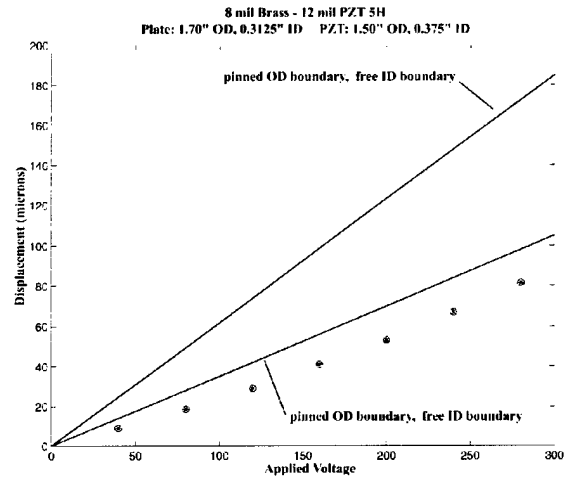

waterplate

Initial Measured Results - Old Design

Acceleration (force) Frequency Response Plot

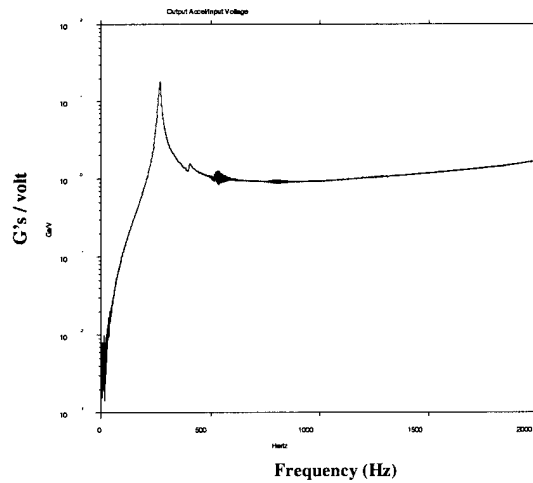

waterplate

Adhesive Layer Significance

adhesive thickness issues - extremely variable thickness over a single part

- ◆ results in inconsistent measured results between otherwise identical parts ($\pm 20\%$)

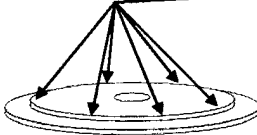
 Measurements of the adhesive layer thickness at the identified locations varied from 1 mil to 3.5 mil on a single wafer-plate

The non-uniformity of the adhesive layer has caused the measured displacement and force output results to be inconsistent between parts and to vary from predictions

waferplate

Electrical Lead Wire Issues

Attachment and placement of leads influences the wafer-plate performance

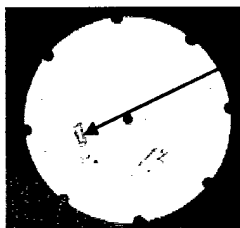

Lead wire attachment point - original actuator

Problem - attachment method created a stress concentration in the piezoceramic, resulted in premature failure when driven at high frequencies;

Problem - electrical arcing occurs between the piezoceramic and the metal connection bolt that runs down through the center when the drive voltage approaches 300 volts (10 kV/in field for this plate)

Power issues: the original actuator is not "self-contained" in that all amplified voltage signals must be provided from an external source. This is a significant hinderence for all actuators.

waferplate

New Wafer-Plate Design

**PZT and substrate thickness selected / matched impedance
or otherwise optimized for some particular desired output**

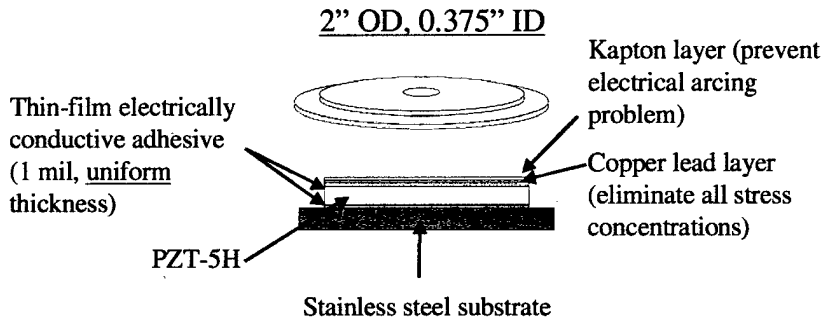

waferplate

Final Configuration - (new development)

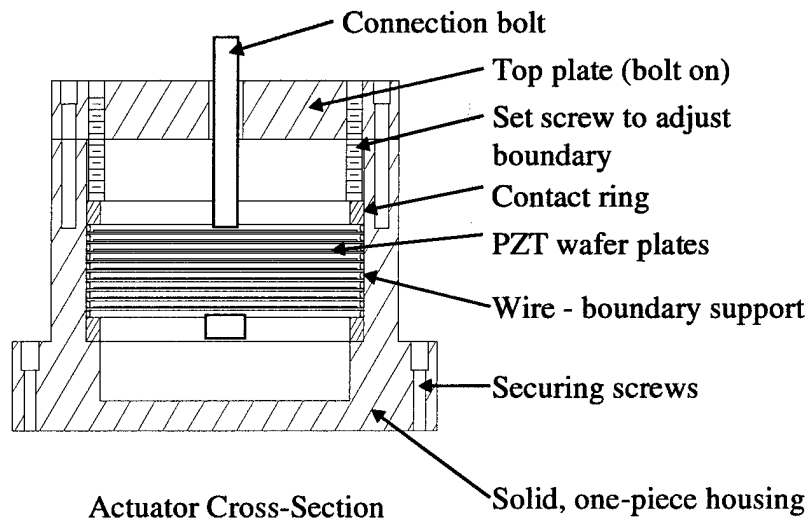

waferplate

Configuration Advantages

Very compact and scalable - (new development)

- ◆ allows for a large number of plates to be used in the actuator (able to meet high force demands)
- ◆ required stroke is attained through varying the diameter, substrate thickness, pzt thickness

the induced boundary conditions on the wafer-plates are as compliant as possible - (new development)

- ◆ minimizes the parasitic strain energy losses into deforming the structure as bending occurs

allows for different plate configurations to be used simultaneously - (new development)

- ◆ attain desired actuator dynamics (discuss this later)

waferplate

Higher Order Modeling - FEA

While low order models (Enhanced Pin-Force, ect) provide reasonable quasi-static results, they are not adequate for detailed levels of design and dynamics

- ◆ many researchers have performed studies showing Finite Element analysis may be applied directly to piezoceramic induced strain actuation problems (notables: Anderson, 1991; Liang, 1997)
- ◆ treat the piezoelectric strain as an eigen-strain (analogous to thermal strains)
- ◆ this is not a new modeling method
- ◆ can be used with Genetic Algorithms to optimize the actuator configuration (new development)

waferplate

Higher Order Modeling

While FE type modeling is ideal for optimizing and verifying the state of the actuator, it is intensive and is not well suited to initial stages of design iterations

Need an intermediate model - Assumed Modes approach:

$$w_{wp}(r, t) = \sum_{i=1}^m w_{\alpha}(r) k_i(t)$$

Leads to:
$$\underline{[M] \{\ddot{c}\} + [K] \{c\} = \{f\} V(t)}$$

waferplate

Predicted Wafer Plate Performance

Free Deflection Surface Plot

PZT 5H wafers @ 15 kV/in

AISI 302 Stainless Steel substrates

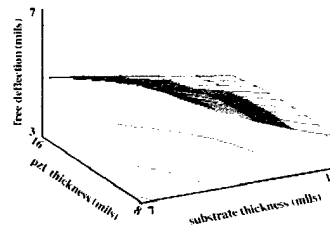
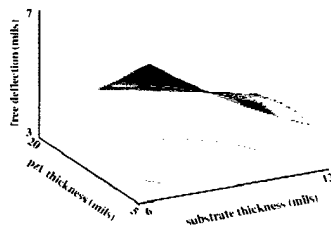

waferplate

Predicted Wafer Plate Performance

Blocked Force Surface Plot

PZT 5H wafers @ 15 kV/in
AISI 302 Stainless Steel substrates

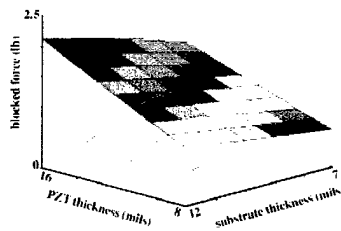

waferplate

Predicted Wafer Plate Performance

Normalized Blocked Force and Free Deflection Plot

PZT-5H wafers @ 15 kV/in
AISI 302 Stainless Steel substrates

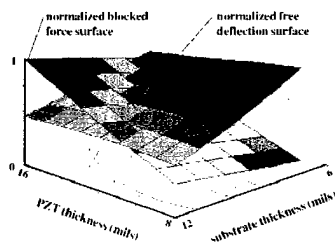

Note: substrate material available in 7, 8, 10 and 12 mil thickness

waferplate

Commercial FEA Comparison

Commercial FEA generated deformation plots -
axisymmetric parabolic solid elements

- ◆ 2 wafer plates: 7 mil stainless steel substrate,
16 mil PZT-5H driven at 15 kV/in

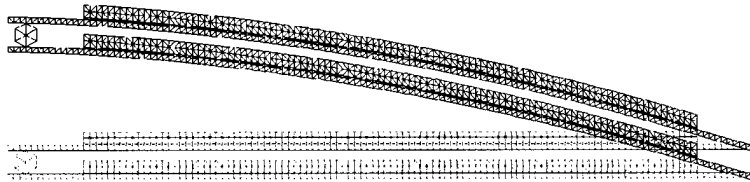

Predictions show that the force output of two
plates is twice that of a single plate; the natural
frequency and free deflection remain the same

waferplate

Actuator Analysis

Finite element analysis shows that when the actuator is
composed of plates of different configurations
(pzt/substrate stiffness or thickness varies from plate to
plate), each plate bends in a mode different from its
natural "solo" bending mode

Plate #1: 10 mil stainless steel, 16 mil pzt Plate #2: 7 mil stainless steel, 8 mil pzt

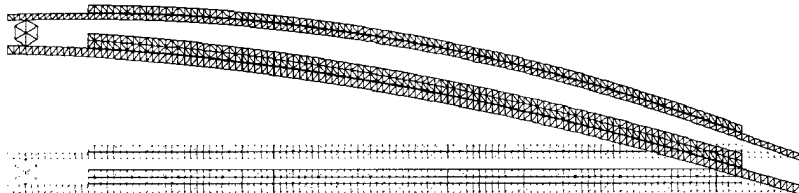

Can this effect be modeled with an Assumed Modes approach?

waferplate

Design / Investigation Issues

Can various wafer-plate configurations be implemented into an actuator to achieve “better” or desired actuator dynamic responses? Each wafer-plate configuration has an unique dynamic response:

- ◆ What happens to the actuator dynamics when it is composed of different wafer-plate configurations?
- ◆ Can this be predicted with an assumed modes model?
- ◆ Measure this experimentally

waferplate

Design / Investigation Issues

Assembled Actuator

composed of “n” different wafer-plates

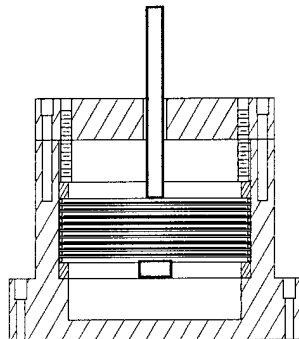

waferplate

General form of each plate's Force FRF

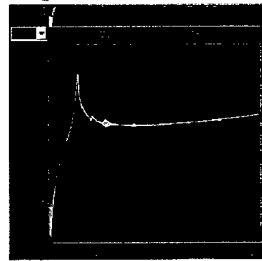

Actuator's Force FRF: can the actuator's resonance peak be expanded suitable for operation within some bandwidth?

What is the effect of multiple plate configurations on the dynamics?

Design / Investigation Issues

Manufacturing Issues: can the wafer-plate manufacturing method be used to enhance performance?

Consider the piezoceramic actuation mode:

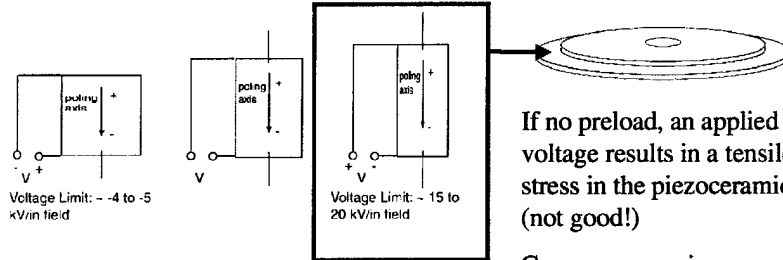

Drive voltages: often 0 to V_{max} volts

If no preload, an applied voltage results in a tensile stress in the piezoceramic (not good!)

Can a compressive residual stress be induced into the PZT during manufacture?

waferplate

Design / Investigation Issues

Consider the manufacturing method shown: \longrightarrow
How does this effect actuator performance?

Results in:

- doming of the PZT wafer plate
- stored strain energy is released through PZT activation!
- Coupling coefficient is higher than the PZT alone.

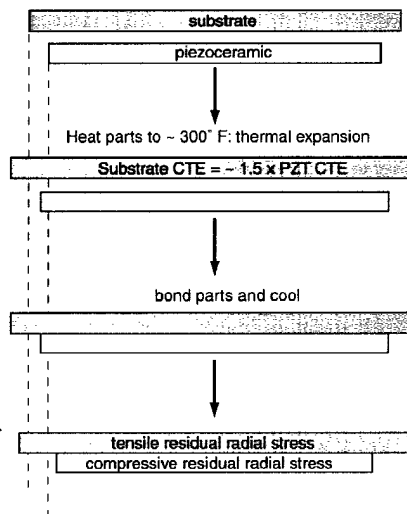

waferplate

What has been done?

Low order modeling and testing of an actuator

- ◆ First order models - predicted response data
- ◆ Built an actuator and measured response data - too many inconsistencies and too much variability
- ◆ Found the significant problems that must be addressed in order to make the actuator successful

Adhesive layer:

thickness - must be uniform over a single part
repeatable - must be uniform over many parts

Electrical leads:

must eliminate the stress concentration
need to provide good contact to large surface area
must eliminate the arcing problem

Proper selection of the substrate material, thickness, pzt thickness - can't be accomplished with low order models

waferplate

Critical Design Issues

Single wafer-plate -versus- scalable actuator

- ◆ single plate: design to maximize work output and efficiency (maximize the electro-mechanical coupling)
- ◆ actuator: usually has a stroke and force requirement
 - often the actuator composed of optimized single plates will not meet the stroke requirements
 - design the plates to meet the stroke requirements then add the number of plates to meet the force requirement

Based on these issues, what is the acceptable design method:

- ◆ want a plug in type criteria:
 - input required force, stroke, and size limitations
 - get out an actuator specification that maximizes the work output while meeting the requirements

waferplate

Work in Progress

Develop an acceptable model method to maximize the actuator work output while meeting the constraints

◆ possible approaches

genetic algorithm wrapped around a finite element model

approach is novel but given the shape of the solution space, is it the best approach?

Finite element model is the only model that will capture all of the pertinent mechanics

Assumed modes model **

does not capture all of the mechanics, but is sufficient with bounds - determine these will work for actuators composed of a common wafer-plate configuration

may not work for actuators composed of different plate configurations - finite elements may be required

waferplate

Work in Progress

Impedance matching criterion

really a sound approach - good initial estimate but not the best approach

Investigate the feasibility of accurately modeling the actuator composed of multiple configuration plates using the Assumed Modes modeling method

◆ the method can be applied, but is it accurate?

waferplate

Work in Progress

■ Experimental work

Build an actuator that overcomes the problems discovered in the first version

measure the effects of OD boundary conditions on the actuator performance - compare to predictions

measure the effects of the adhesive layer thickness on the actuator performance - compare to predictions

measure the effects of the substrate stiffness on the actuator performance - compare to predictions

measure the scalability of the actuator: the effects of multiple common configuration plates on the performance - compare to predictions

measure the effects of multiple configuration plates on the actuator performance - compare to predictions

waterplate

Work in Progress

Experimental work (continued)

Investigate the manufacturing issues

can a beneficial compressive residual stress be introduced into the PZT during the manufacturing process?

waterplate