

180106

JPRS-CST-84-013

8 May 1984

19981112 118

# China Report

SCIENCE AND TECHNOLOGY

DTIC QUALITY INSPECTED 3

**FBIS**

FOREIGN BROADCAST INFORMATION SERVICE

REPRODUCED BY  
NATIONAL TECHNICAL  
INFORMATION SERVICE  
U.S. DEPARTMENT OF COMMERCE  
SPRINGFIELD, VA. 22161

5  
60  
A04

#### NOTE

JPRS publications contain information primarily from foreign newspapers, periodicals and books, but also from news agency transmissions and broadcasts. Materials from foreign-language sources are translated; those from English-language sources are transcribed or reprinted, with the original phrasing and other characteristics retained.

Headlines, editorial reports, and material enclosed in brackets [] are supplied by JPRS. Processing indicators such as [Text] or [Excerpt] in the first line of each item, or following the last line of a brief, indicate how the original information was processed. Where no processing indicator is given, the information was summarized or extracted.

Unfamiliar names rendered phonetically or transliterated are enclosed in parentheses. Words or names preceded by a question mark and enclosed in parentheses were not clear in the original but have been supplied as appropriate in context. Other unattributed parenthetical notes within the body of an item originate with the source. Times within items are as given by source.

The contents of this publication in no way represent the policies, views or attitudes of the U.S. Government.

#### PROCUREMENT OF PUBLICATIONS

JPRS publications may be ordered from the National Technical Information Service, Springfield, Virginia 22161. In ordering, it is recommended that the JPRS number, title, date and author, if applicable, of publication be cited.

Current JPRS publications are announced in Government Reports Announcements issued semi-monthly by the National Technical Information Service, and are listed in the Monthly Catalog of U.S. Government Publications issued by the Superintendent of Documents, U.S. Government Printing Office, Washington, D.C. 20402.

Correspondence pertaining to matters other than procurement may be addressed to Joint Publications Research Service, 1000 North Glebe Road, Arlington, Virginia 22201.

8 May 1984

# CHINA REPORT

## SCIENCE AND TECHNOLOGY

### CONTENTS

PEOPLE'S REPUBLIC OF CHINA

#### APPLIED SCIENCES

Prospects of Nuclear Energy Resources Assessed (Yang Yaochen; HEDONGLI GONGCHENG, No 4, 1983) .....	1
Development of Boiling-Water Graphite Moderated Reactor in USSR (Dong Yin, Yang Shuiquan; HEDONGLI GONGCHENG, No 4, 1983) .....	11
Design Features of 300 MW PWR Power Stations Described (Pan Xiren, Zhao Jiarui; HEDONGLI GONGCHENG, No 4, 1983) .....	25
Primary Steam Generator of 450 MWt Nuclear Heat Supply Plant Detailed (Gan Jianheng; HEDONGLI GONGCHENG, No 4, 1983) .....	36
National Atomic and Nuclear S&T Applications Exhibition Held in Beijing (HE DIANZIXUE YU TANCE JISHU, No 6, 1982) .....	46
Microcomputer Multichannel Analyzer, Microcomputer Mossbauer Spectrometer Pass Evaluation Tests (Zhang Baukang; HE DIANZIXUE YU TANCE JISHU, No 6, 1982) .....	49
Planning Symposium for Modular Machine Tool Trade Held in Dalian (Zhang Xiong; ZUHE JICHUANG, No 12, 1983) .....	51
Nondestructive Testing of Composites Discussed (Chen Jimao; WUSUN JIANCE, No 3, 1983) .....	53

PROSPECTS OF NUCLEAR ENERGY RESOURCES ASSESSED

Chongqing HEDONGLI GONGCHENG in Chinese Vol 4 No 4, 1983 pp 35-41

[Article by Yang Yaochen [2799 5069 5256]: "Views on the Prospects of Developing Nuclear Energy Resources"]

[Text] I. Introduction

Today's world energy consumption is the equivalent of approximately 8 billion tons of coal per year. By the middle of the next century, the world energy consumption is expected to be 5 times the present level, but energy production,<sup>1</sup> based on the present energy structure, will drop to the level of the 1970's. Therefore, without the emergence of new energy resources, a worldwide "energy shortfall" will appear beginning in the next century. Hence, research on the development of new energy resources is a very active topic worldwide.

Due to the limitation of resources, the thermal fission as an energy source will enter its late stage by the middle of the next century. It is still hard to say whether fast breeder reactors can fill the void and become the main force in energy production. Because of extreme technical sophistication, pure fusion energy is still in the distant future. Fusion-fission hybrid reactor, owing to its distinct advantage of modest fusion and high-energy breeding rate (including nuclear fuel), is a very promising energy resource.

II. Prospects for Fission Reactors

Along with the continuous improvement in production and living standard, the consumption of electrical energy has increased year after year. (The more developed a nation is, the faster the increase in electrical energy consumption.) Nuclear energy based on fission reactors is gaining an increasing percentage in electrical energy production, almost 10 percent of the total electrical energy production come from nuclear power. To maintain the important contribution of fission energy, there must be a sufficient supply of the fission material--uranium. In today's thermal neutron reactor age, the fuel is mainly the fissionable isotope  $^{235}\text{U}$  which accounts for 0.7 percent of naturally occurring uranium. Hence, approximately 6,000 tons of uranium oxide are needed to provide  $^{235}\text{U}$  to a standard light water reactor power station with a lifespan of 30 years.

The amount of uranium reserve is rather uncertain. According to the U.S. Department of Energy estimates,<sup>2</sup> the United States has approximately 4 million tons of uranium reserves, including verified, unverified, and expected reserves. This amount can supply 700 standard nuclear power plants for one lifetime. They estimate that by the end of this century, the United States will have 300 to 400 such power plants. Thus, the uranium reserve will be depleted in the first half of the next century.

In order to prolong the life of fission energy, one of the important tasks of today's nuclear energy workers is to broaden the supply of uranium. Possible approaches include the following. (1) Reprocessing of used fuel by nuclear chemical means may increase the effective reserve by 25 percent.<sup>2</sup> (2) Improving the separation technique by adopting new isotope separation methods to reduce the <sup>235</sup>U loss in the "tailing." This is expected to reduce the <sup>235</sup>U content in the "tailing" from 0.25 percent to 0.08 percent.<sup>2</sup> (3) Adopting the "advanced conversion reactor" (ACR) highly regarded by nuclear scientists of Princeton University in the United States. They believe that ACR can greatly prolong the life of fission energy and represents a good approach to increase the supply of nuclear fuel.<sup>3</sup> Hence some people are forcefully advocating immediate actions to promote ACR because otherwise the uranium fuel will be depleted by conventional light water reactors before ACR's are developed.<sup>4</sup> (4) Devoting a major effort on fast neutron breeder reactor. In view of the small amount of <sup>238</sup>U to <sup>239</sup>Pu conversion in thermal fission, the thermal neutron nuclear power stations use at most 1 to 2 percent of the uranium. Most of the <sup>238</sup>U remain unused. Hence the utilization of <sup>238</sup>U has been an issue of concern since the beginning of the fission power research. After 20 years of study in the field of fission reactor, fast neutron breeder reactor was found to be the most effective means of broadening the supply of nuclear fuel. In a fast breeder reactor, the fission material is <sup>239</sup>Pu (with a higher neutron yield than <sup>235</sup>U) obtained from conventional thermal neutron power reactors. Outside the reactor core, it is surrounded by a breeding zone consisting of secondary breeding material <sup>238</sup>U. The amount of new fission material generated in the reactor core and in the breeding zone by the neutrons emitted from the reactor core is greater than the amount of fission material consumed in the reactor core. Because of the dual advantages of being practical (it produces electrical energy) and serving the future (it produces fission material) of the fast breeder reactor, many developed nations have included the development of the fast breeder reactor as part of their energy policy. The unused secondary breeding material mainly refers to <sup>238</sup>U and <sup>232</sup>Th. Sodium-cooled fast breeder reactors are suitable for the <sup>238</sup>U-<sup>239</sup>Pu cycle and they are making the transition toward commercial use. For example, after France built its prototype fast breeder reactor, the "Phénix," it has quickly built the Superphénix for the transition toward large-scale commercialization and it is expected to go critical in 1983. On the other hand, helium-cooled fast breeder reactor for the <sup>232</sup>Th-<sup>233</sup>U cycle is still in the research stage. While taking notice of the active side of the fast breeder reactor, we must also be aware of the problems existing in it. Using the French "Superphénix" as an example, it has an electrical power of 1,200 MW and takes 4 tons of plutonium for the preload. This great amount of plutonium is unthinkable in a nation without a sufficient number and running time of high power thermal neutron power reactors. Furthermore, the fuel doubling time of this reactor

is about 30 years (10-20 years with improved design), it would be the end of this century or the beginning of the next century before another "Superphénix" can be built, assuming the first one goes critical in 1983. These two major problems with the fast breeder reactor and other safety problems more troublesome than thermal neutron reactors will prevent fast breeder reactors from dominating the world energy balance in the future.

### III. Prospects for Pure Fusion Reactors

#### 1. Development of nuclear fusion technology

Since the early 1970's, along with progress in plasma heating technology, there has been rapid developments in magnetic confinement devices (especially the Tokamak device). Figure 1 shows the relationship between the Q value and date for several recent ring devices that have been or will be in operation. (Q is defined as the ratio of the energy released by a unit volume of plasma undergoing fusion to the energy of a unit volume of plasma.) As can be seen, in a short 6 or 7 years, the Q value of a Tokamak has jumped from the  $10^{-6}$  of Ohmic heating ATC device to almost 1 for the TFTR device with an injection power of 20 MW accompanied by an increasing power neutral beam injection technique. Numbers in parentheses are the injection power. The scientific feasibility of controlled thermal nuclear fusion was therefore verified. The rapid increase in the Q value and the sharp drop in cost<sup>5</sup> for plasma heating (from \$4/W for PLT to less than \$1/W for MFTF) are the best measures of the development of nuclear fusion research. Moreover, the gradual approach of the designed plasma radius based on the pure fusion reactor concept and the experimentally achieved plasma radius (see Fig. 2) also demonstrates the promising prospects of nuclear fusion.

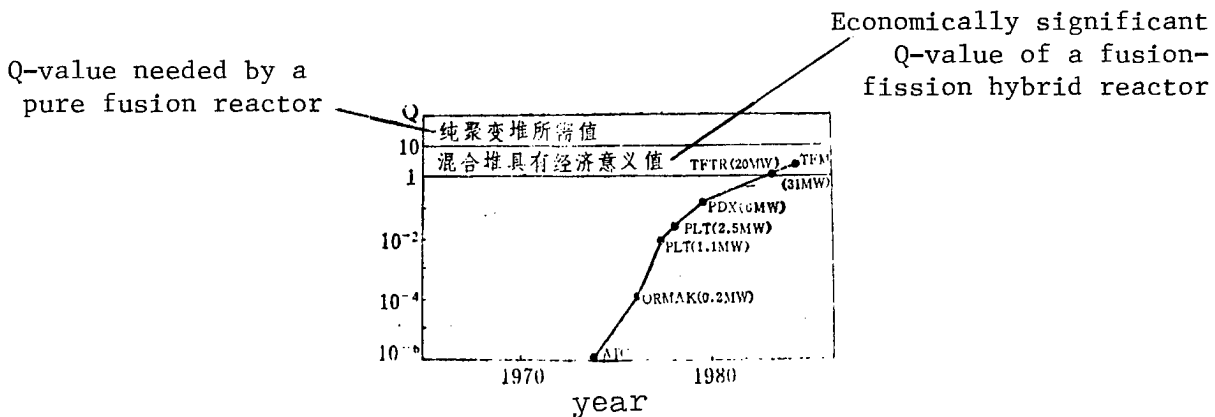

Fig. 1. Increase of Q Value

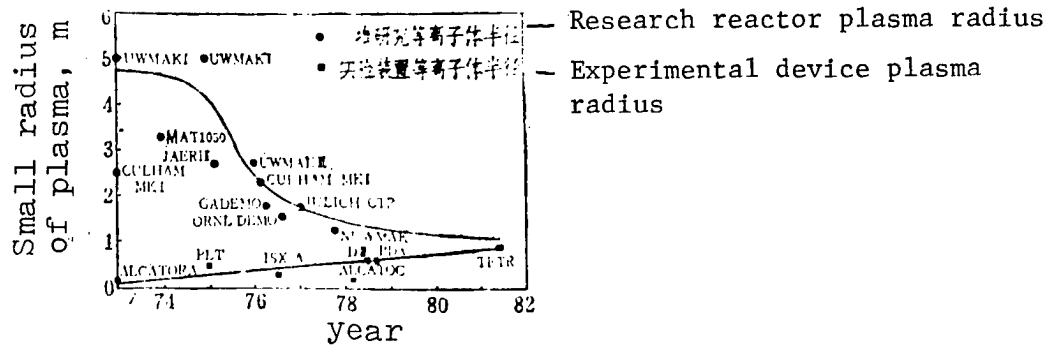

Fig. 2. Convergence of the Theoretical and Experimental Plasma Radius

## 2. Difficulties in pure fusion reactors

The electric energy input to output ratio  $Q_e$  of a pure fusion reactor as given by Ref. 6 is:

$$Q_e = \frac{(1 + Q) \eta_e \eta_d}{Q Q_s^{-1} \eta_d + 1} \quad (1)$$

Where  $Q_e = e_F/e_s$ ,  $e_F$  is the fusion energy released by a unit volume of D-T plasma,  $e_s$  is the electric energy required to establish a unit volume of D-T plasma (not including the energy consumed to heat the plasma),  $\eta_e$  and  $\eta_d$  are respectively the conversion efficiencies from heat to electricity and from electricity to heat. Assuming  $\eta_e = 0.3$  and  $\eta_d = 0.6$ , we obtain the value of  $A$  at breakeven ( $Q_e = 1$ )

$$Q \approx 1 / (0.22 - 0.73 Q_s^{-1}) \quad (2)$$

As can be seen from Equation 2, the necessary condition for electrical breakeven of a pure fusion reactor is  $Q_s$  greater than or equal to 3.3. This is a very demanding requirement. Based on data released by INTOR,<sup>7</sup> the reactor jointly designed by the United States, Japan and Western Europe and scheduled to be built by the end of this century, its  $Q_s$  is approximately 2. If  $Q_s$  can be made to reach 5 (an extremely difficult task), the  $Q$  value needed for a pure fusion reactor to break even electrically is still greater than or equal to 12.5

The difficulty for a pure fusion reactor to become commercially viable can be clearly seen from its net electrical power output<sup>6</sup>:

$$P_{net} / P_F = \eta_e + (\eta_e - \eta_d^{-1}) Q^{-1} Q_s^{-1} \quad (3)$$

where  $P_{net}$  is the net electrical power output,  $P_F$  is the fusion power of the fusion of the fusion reactor core. Equation (3) shows that, when  $Q_s = 3.3$ ,

the net electrical power output of a pure fusion reactor is zero. For  $A = 100$ ,  $Q_s$  must be greater than 5 for the net electrical power output to be 10 percent of the fusion power. A higher net electrical power output would require an even higher value of  $Q_s$ . Therefore it is no exaggeration to say that the commercialization of pure fusion reactor as an energy source would require the effort of generations of people on earth.

#### IV. Superiority of Fusion-Fission Hybrid Reactors

##### 1. Concept of the hybrid reactor

By surrounding a D-T fusion device with a blanket consisting of breeding material  $^{238}\text{U}$  or  $^{232}\text{Th}$  or other actinium series elements as the principal constituent, a fusion fuel cycle is completed. The type of principal breeding material in the blanket determines the function of the hybrid reactor. Lithium, an element essential to conventional pure fusion reactor, must also be included in the proper locations of the blanket to regenerate tritium. High-energy neutrons at 14.06 MeV are generated in the fusion process of the D-T plasma in the fusion reactor core:

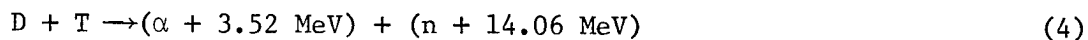

These neutrons travel in the blanket and undergo the following physical processes: (1) Neutron multiplication. One D-T source neutron may react with neutron multipliers in the blanket and undergo (n,2n) or (n,3n) process and produce several slower neutrons. (2) The source neutron or secondary neutron may react with lithium (mainly  $^6\text{Li}$ ) and regenerate tritium:



(3) The neutrons may be captured by the breeding material and produce new fission materials such as  $^{239}\text{Pu}$  or  $^{233}\text{U}$ ; (4) The neutrons may cause fast fission or thermal fission of the breeding material in the blanket and produce energy and neutron multiplication.

Since each fission produces about 200 MeV of energy, if a D-T source neutron (including the secondary neutron it produces) can induce one fission in its lifetime, the energy breeding ratio will be greater than 10. More importantly, each fast neutron can produce several slower neutrons in the blanket to be captured by the breeding material and transform to one or several new fission nuclei and one or more tritium nuclei. Since the blanket of the hybrid reactor operates in the subcritical state, the safety of the system is enhanced. One hybrid reactor may "carry" several "satellite" fission reactors to form a system and the cost will be cheaper than pure fission reactor or fast breeder reactor. The hybrid reactor greatly reduces the fusion requirements and has practical economic meaning as long as  $Q \gg 1$ . Therefore, the fusion-fission hybrid reactor shows great promise in the rapid and large-scale production of fission fuel and power and provides new energy sources economically and safely.

The performance of a fusion-fission hybrid reactor is generally expressed in terms of the fuel breeding ratio  $F$ , tritium breeding ratio  $T$  and energy multiplication factor  $M$ . The meanings of  $F$ ,  $T$  and  $M$  are respectively the number of fuel nuclei and tritium nuclei produced by one D-T source neutron and the energy multiplication number with respect to each fusion energy.<sup>6</sup>

## 2. Progress in hybrid reactor research

The original idea of a hybrid reactor intended for military purposes was proposed in 1953 by F. Powell<sup>8</sup> of Lawrence Livermore Laboratory in the United States with the help of E. Teller, R.F. Post and D.H. Imhoff. Two years later, J.D. Lawson<sup>9</sup> of Harwell in Great Britain also proposed similar concepts independently. But because of insufficient understanding of the interaction characteristics between D-T fusion neutron and uranium and lithium and limitations in computing technique, all the results were estimates and contained errors. Moreover, the entire controlled fusion field encountered great technical difficulties at the time and was in an inactive period. As a result, only a few very crude concepts of hybrid reactor were proposed in the 1960's. Nonetheless, they should not be forgotten as the pioneers of the fusion-fission hybrid reactor.

Along with the progress of magnetic confinement fusion research in the late 1960's and the rapid development of electronic computer technology, hybrid reactor research entered an active period. In 1965 L.N. Lontai<sup>10</sup> of MIT in the United States first performed the economic computation of fusion neutrons in the blanket of a hybrid reactor using computer and moved hybrid reactor research forward by a big step. Starting with the rate of tritium generation, Lontai carried out computations for four different structures--the standard blanket, the fusion first wall, the fusion first wall coolant and the fusion breeding zone--for different concentrations of  ${}^6\text{Li}$ . Since it was the first attempt, the results were less than satisfactory.

In 1969, L.M. Lidsky<sup>11</sup> of MIT proposed the "Fission-Fusion Symbiosis" in the CLM nuclear fusion reactor conference. Lidsky studies a symbiotic central reactor consisting of D-T fusion reactor with a blanket containing  ${}^{232}\text{Th}$  and molten FLiBe and a thermal neutron molten salt conversion reactor using  ${}^{233}\text{U}$  as fuel.

A common feature of the hybrid reactors studied by Lontai and Lidsky is that they both have a molten salt blanket. In view of the blanket structure of the two reactors one can draw the following important criterion: when the U-Pu cycle is used, the blanket should use the fast neutron spectrum, and when the Th-U cycle is used, the blanket should use the slow neutron spectrum. The reason is clear: for  ${}^{238}\text{U}$  the fast neutron cross-section dominates, and for  ${}^{232}\text{Th}$  the thermal neutron capture cross section dominates.

Subsequently in 1970-1972, J.D. Lee<sup>12</sup> of LLL in the United States published a study of the subcritical fast fission blanket hybrid reactor (magnetic lens model) and B.R. Leonard, et al.,<sup>13</sup> of PNL published a study of the thermal fission blanket (the Tokamak model). These two studies have perfected the fundamental concepts of a hybrid reactor. Lee studied the three cases of

surround the large magnetic lens of a 1.6 m radius D-T plasma with pure  $^{232}\text{Th}$ , pure  $^{238}\text{U}$  and naturally occurring uranium. The blanket of the magnetic lens hybrid reactor is a double spherical ring with an inner diameter of 2 m and a thickness of 1 m. The unique feature of the work by Lee is that he considers the Pu recycle in the blanket and the effects on the yield after fission products (F·P) accumulates in the blanket after a period of running. If this magnetic lens reactor was a pure fusion reactor, the Lawson criterion requires  $T_i \approx 60$  keV and  $n_i$  (pure)  $\approx 1 \times 10^{15}$   $\text{cm}^{-3}$  in the plasma. But in Lee's hybrid reactor, an ion density of only  $n_i$  (hybrid)  $\approx 2.7 \times 10^{14}$   $\text{cm}^{-3}$  is needed to reach a neutron flux of  $2.86 \times 10^{20}$  n/s provided the ion temperature is still  $T_i \approx 60$  keV. Thus, Lee's plasma lowered the Lawson criterion by a factor of 4. The purpose of the study by Leonard et al. is an attempt to solve the neutron kinetics of a "self-sustaining power station" (although the thermal neutron fission zone is subcritical). Their hybrid reactor is based on a D-T Tokamak thermal neutron fission concept. Its composite blanket consists of a "fusion" blanket and a "fission" blanket. The role of the "fusion" blanket near the plasma is to provide sufficient gain for the source neutron and to provide energy gain through the fast neutron fission of  $^{238}\text{U}$ . It also makes an important contribution to the breeding of  $^{239}\text{Pu}$ . The "fission" blanket outside the "fusion" blanket is actually a subcritical high temperature, gas-cooled, graphite reactor using natural uranium or low concentration  $^{235}\text{U}$ . The Leonard reactor has the following features: (1) Extremely high-energy breeding ( $M = 30-90$ ); (2) Good nuclear productivity ( $F \approx 1$ ); (3) Low wall load ( $0.05 \text{ MW/m}^2$ ); (4) Subcritical ( $k_{\text{eff}} = 0.8 - 0.9$ ); (5) Sub-Lawson criterion; (6) More conventional technology since the molten salt is done away with.

It is fair to say that beginning with Leonard's work the physics and engineering of hybrid reactor received overall consideration and the concept of hybrid reactor has led to the active research of hybrid reactor design in recent years.

The development of controlled fusion in the 1970's and the extensive work on the physics of hybrid reactor have made more and more people accept the concept of the hybrid reactor. It is no longer any doubt that the fusion-fission reactor is an indispensable bridge in the transition from fission energy to pure fusion energy. Even though the governments of the western nations do not publicize this viewpoint--because of the objection to nuclear energy of the residents and the mass media--but the scientists have been doing the work. As the research on hybrid reactors gained depth, it progressed from solving the neutron physics problems to the study of fuel recycle, (Pengyuan) effect, first wall material and blanket optimization.<sup>15-18</sup> It has also moved from isolated individual study of specialized topics to the collective multidisciplinary (including plasma physics, reactor physics, heat engineering, superconducting magnets, material structure and shielding) simulation of various designs.<sup>19</sup>

### 3. Advantages of the hybrid reactor

The fusion-fission hybrid reactor greatly reduces the fusion requirements and may advance the fusion technology by several decades. As discussed above, the

plasma criteria of hybrid reactors are much less stringent than the Lawson criterion. We may also consider this problem from an engineering point of view. When the input-output electric energy ratio  $Q_e$ , given by the following, is equal to 1,

$$Q_e = \frac{[(0.8M + 1) Q + 1] \eta_e \eta_d}{QQ_s^{-1} \eta_d + 1} \quad (7)$$

the hybrid reactor achieves electrical breakeven. Suppose  $\eta_e = 0.3$ ,  $\eta_d = 0.6$ , and  $M = 10$  (this is easily achieved in an U-Pu cycle hybrid reactor), the condition for electrical breakeven is

$$Q \approx 1/(2 - 0.7Q_s^{-1}) \quad (8)$$

where the critical value of  $Q_s$  is about 0.35. Thus, the engineering technical target for a hybrid reactor is one order of magnitude lower than that of a pure fusion reactor. This advantage of the hybrid reactor can also be clearly seen in its net electrical power output<sup>6</sup>

$$P_{\text{net}}/P_F = (1 + 0.8M) \eta_e + (\eta_e - \eta_d^{-1}) Q^{-1} - Q_s^{-1} \quad (9)$$

As pointed out earlier, for a pure fusion reactor to achieve a net electrical power output of 10 percent of the fusion power, it must reach an unimaginable engineering level of  $Q \approx 100$  and  $Q_s \approx 5$ . For a hybrid reactor to achieve a net electrical output of 200 percent of the fusion energy, it only has to reach a modest engineering level of  $Q \approx 7$  and  $Q_s \approx 2$ .

Another advantage that comes automatically with the high energy breeding is the extremely high ability to generate nuclear fuel. Table 1 lists the number of standard light water reactors that can be supplied by various types of fuel breeders (including hybrid reactors with different blanket breeder material and fast breeder reactor). As can be seen, for the same electrical power output, a hybrid reactor is equivalent to about eight fast breeder reactors in the ability to produce nuclear fuel. It is indeed encouraging that the hundreds of million tons of uranium and thorium resources in the world have found such a good conversion scheme.

Table 1. Number of LWR That Can Be Supplied by Various Fuel Breeders

Fuel breeder		Number of standard LWR
Hybrid reactors	$^{232}\text{Th}$ as breeding material	5
	$^{238}\text{U}$ $^{232}\text{Th}$ as breeding material <sup>2</sup>	4
	$^{238}\text{U}$ as breeding material <sup>6</sup>	4
Fast breeder reactor	Superphénix <sup>6</sup>	0.5

For a hybrid reactor to produce nuclear fuel, it is only necessary to load the blanket with secondary breeding material and no need to preload the reactor with fission material. This makes the rapid large-scale production of high-grade nuclear fuel possible. In comparison, the fast breeder reactor requires tons of plutonium to preload and cannot compete with the hybrid reactor.

As long as the concentration of the newly generated nuclear fuel  $^{239}\text{Pu}$  or  $^{233}\text{U}$  is kept below a certain level, the hybrid reactor blanket can be kept in a subcritical state indefinitely. As soon as the fusion reactor core shuts down, the chain reaction also stops. The safety of a hybrid reactor cannot be rivaled by any type of fission reactor.

With the rapid development of nuclear power stations, the strongly radioactive and long half-life actinium series elements will also increase. The buildup of the nuclear waste which cannot be eliminated by any known method is one of the main reasons for people's rejection of the fission energy source. Using these actinium series elements as the breeding material for hybrid reactors, we have a unique rapid method to treat the nuclear waste on a large scale and obtain some energy gain at the same time.<sup>20</sup>

## V. Discussion

The fusion-fission hybrid reactors have indeed greatly lowered the fusion criterion but they nevertheless require a certain degree of fusion criterion, such as  $Q \geq 1$ . To a few developed countries this condition is expected to be satisfied in the immediate future, but the level of nuclear fusion experiment in China is still 10-20 years behind the advanced world standard. The prerequisite for the development of the hybrid reactor is therefore a fusion technology level at that of the international "big four." To shorten the distance from the advanced international standard, China must make a major effort to develop the experimental research of controlled fusion devices and the corresponding industrial technology such as high power pulse electric source, large capacity superhigh vacuum technique, practical low temperature (liquid helium) superconductivity technology, processing of specialized material, large power neutral beam injection technique and microwave heating technology, in addition to the research of plasma physics needed for the construction of reactors (such as the equilibrium and stability problem of thermal nuclear plasma in the presence of  $\alpha$  particles). In the meantime, China should also be actively developing the research and experiment associated with hybrid reactor components such as the development of the first wall that can endure a high neutron flux, tritium technology, liquid lithium and lithium-lead alloy technique and the heat transfer technique of the first wall.

Having fully recognized the practicality and superiority of hybrid reactors, we should consider hybrid reactors as one of the future nuclear energy sources.

## REFERENCES

1. Institute of Nuclear Technology, Qinghua University, reference material: "High Temperature Gas-cooled Reactor and Nuclear Energy-Coal Conversion," 1980.
2. A. Bethe, PHYSICS TODAY, 5 (1979).
3. H.A. Feiveson, et al., SCIENCE, 330 (1979).
4. Y.I. Chang, et al., RSS-TM-4 (1977).
5. U.S. Department of Energy, EOE/ET-0116/1 (1979).
6. Yang Yaochen, "A Promising Energy Source: Fusion-Fission Hybrid Reactor, Nuclear Fusion and Plasma Physics," Vol 1, No 2, 1981, p 74.
7. INTOR Group, NUCLEAR FUSION, 349 (1980).
8. F. Powell, LWS-24920 (1953).
9. J.D. Lawson, AERE/GP/M185 (1955).
10. L.N. Lontai, "Study of a Thermonuclear Reactor Blanket With Fissile Nuclides," MIT Tech. Rep. 446 (1965).
11. L.M. Lidsky, "Fission-Fusion Symbiosis: General Considerations and Specific Example CLM-NFR," 41 (1969).
12. J.D. Lee, UCRL-73952 (1973).
13. B.R. Leonard, et al., BNWL-SA-3671A (1970).
14. J. Kimlinger, et al., UCRL-50532 (1968).
15. E.T. Cheng, et al., GA-A16509 (1981).
16. E. Greenspan, et al., PPPL-1444 (1978).
17. Yang Yaochen, NUCLEAR SCIENCE AND ENGINEERING, Vol 2, No 2, 1982, p 148.
18. Yang Yaochen, "Optimization of the Blanket of a Tokamak Fusion-Fission Hybrid Reactor," to be published.
19. R.W. Moir, editor, UCID-18808 (1980).
20. R.P. Rose, EPRIER-451 (1976).

9698

CSO: 8111/0243

DEVELOPMENT OF BOILING-WATER GRAPHITE MODERATED REACTOR IN USSR

Chongqing HEDONGLI GONGCHENG in Chinese Vol 4 No 4, 1983 pp 72-79

[Article by Dong Yin [5516 5419] and Yang Shuiquan [2799 3055 3123]: "Development of Boiling-Water Reactor (Graphite Moderated) in the USSR"]

[Text] The Soviet large power boiling water cooled and graphite moderated reactor has a number of advantages. According to reports, the Soviet Union is building and plans to build two types of nuclear power plants: graphite moderated boiling-water reactor and pressurized-water reactor. Their technical strategy in nuclear power development is to give priority to the development of large power graphite moderated boiling water reactors (single station powers of 1,000, 1,500, 2,000 and 2,400 MW) while at the same time building 1,000 MW PWR power plants. In this article we briefly introduce the development status of the Soviet PBMK [RBMK] graphite moderated boiling-water reactor power plant.

I. Introduction

The Soviet power reactor using graphite moderated and boiling water cooling was developed from its military nuclear reactor. In July of 1944 the first Soviet graphite zero power device reached critical. From 1947 to 1952, the Soviet Union subsequently built six light water reactors using natural uranium and graphite in the Urals. On this basis they have conducted graphite LWR research and development since the early 1950's. On 27 June 1954, the first Soviet nuclear power plant with 5,000 kW power went into operation in Obninsk near Moscow. From 1958 to 1964, six more single reactor 100 MW nuclear power plants were built. They are of the Siberia pressurized tube type light water reactor using natural uranium as fuel and graphite as moderator and serve the dual purpose of electric power production and plutonium production. At this stage, the Soviet Union finished its first phase of developing pressurized tube graphite and light water power reactor. The second phase is marked by the construction of the 300 MW Beloyarsk power plant with dual reactors (one 100 MW reactor and one 200 MW reactor). The two reactors were built and put into operation in the period of September 1963 to December 1967 and the main feature is the achievement of industrial level nuclear superheating in the reactors. The year 1973 saw the start-up of the first PBMK-1000 graphite boiling water reactor in Leningrad which went into industrial operation at the end of 1973 and achieved rated power in 1974.

After that the graphite boiling-water reactor entered the construction phase of 1,000 MW commercial-scale power stations. In 1975 and 1979, the second and third similar devices were put into operation. Today these three reactors in Leningrad are operating reliably and steadily and carry a basic load in the power grid. In addition to these three reactors, two more PBMK-1000 reactors are also operating safely in Kursk and Chernobyl power plants. Today the total power of Soviet nuclear power plants already in operation and under construction is 20,000 MW. In their 10th Five-Year Plan, more than half of the nuclear power is produced by PBMK-1000 reactors. The 11th Five-Year Plan and 5-year plans after that, all call for the development of PBMK-1000 and PBMK-1500 pressurized tube graphite boiling-water reactors. Each 1,000 MW reactor is equipped with two 500 MW turbine generators and each 1,500 MW reactor is equipped with two 750 MW turbine generators. The power production costs of the PBMK-1000 and the PBMK-1500 are respectively 0.617 and 0.543 kopek/kwh, the latter is 14 percent lower than the former.

Reports show that there will be large developments in the Soviet's nuclear power industry in the next 10 years. Their technical strategy is to give priority to the development of graphite boiling-water reactor power plants while building 1,000 MW PWR power plants. According to a report in the first issue in 1981 of the Soviet journal ATOMIC ENERGY, the total power of Soviet nuclear power plants already in operation is 12,910 MW (approximately 5 percent of total electrical power generation capacity) and out of which 7,955 MW were produced by graphite reactors, which account for 61.6 percent of the total nuclear power (see Table 1).

## II. Characteristics of Graphite Moderated Boiling-Water Reactors

Graphite moderated boiling-water reactors have the following features

- (1) This type of reactor uses a direct circulation of steam in a single loop, the system layout is simplified and there is no need to have a large pressure vessel, a large steam generator, a high pressure circulation water main pump, extra-large diameter high-temperature and high-pressure pipes in the primary circuit and the associated components. The steam is generated directly in the reactor and, after steam-water separation, is fed into the turbine. After the steam does the work, it is condensed and returned to the reactor, thereby achieving the simplest conversion from steam energy to electrical energy. The cooling return circuit of the reactor is a 60-90 kg/cm<sup>2</sup> medium pressure system and is easy to operate and maintain.
- (2) Each process tube in a pressurized tube reactor is an independent heating unit and its operating conditions such as temperature, flow rate and humidity may be independently monitored. To increase the reactor power, one is not limited by the manufacture ability of pressure vessels, and the difficulties of transporting large bulky equipment are avoided. The pressurized tube may make use of standard components.
- (3) When graphite is used as the material for the moderator and reflector, it can be machined into various shape and dimension at a low cost. Graphite has good nuclear characteristics, it is a good moderator and reflector material,

Table 1. Soviet Nuclear Power Stations in Operation as of June 1980

Number	Station name	Time from start-up of first reactor to last reactor(year)	Total power (10MWe)	Reactor type	Remarks
1	Obninsk	1954, June	0.5	Graphite PWR with small circuit	Phase I, total power: 605 MWe
2	Novosibirsk	1958-1964	6x10	Graphite PWR for plutonium production and electricity generation	
3	Novovoronezh	1964-1980	245.5	Four 440 MWe PWR one 1,000 MW PWR	Phase II, total power: 3,477 MWe
4	Beloyarsk	1964-1980	90	1x100, 1x200 MWe graphite nuclear superheating reactors, 1x600 MWe sodium cooled fast [neutron] reactor	
5	(Wulinqyang-nuofusike)	1965-1969	6.2	1x2 MW boiling-water reactor, 1x60 MW bH-60 fast [neutron] reactor	
6	Kursk	1973-1976	2x44	PWR	Phase II late stage total power: 1,228 MWe
7	Bilibino	1973	4.8	Pressurized tube graphite boiling water reactor	
8	(Xuefuling-hosike)	1973	35	БН-350 sodium cooled fast [neutron] reactor	
9	Armenian-2	1976-1979	81	PWR	Phase III, begin batch construction of PBMK power stations, total power: 7,810 MWe
10	Leningrad	1973-1979	3x100	РБМК-1000	
11	Kursk	1976-1979	2x100	"	
12	Chernobylo	1977-1979	2x100	"	

only next to heavy water, and it has a higher moderation ratio and reflection coefficient than beryllium oxide and beryllium.

(4) In a graphite boiling-water reactor the loading and unloading of fuel and the changing of malfunctioned tube can be done without shutting down the reactor. This helps to increase the utilization rate of the facility and the load factor of the nuclear power plant. At the present time the average load factor is 0.65-0.74.

(5) The graphite reactors, however, do have a large volume and require more on-site installation work and a longer construction period and the reactor core requires more fuel. The electricity generation cost of graphite reactors with a power less than 1,000 MWe cannot compete with PWR power plants.

### III. P5MK-1000 Reactor Core Construction

Based on physical and heat engineering calculations, the P5MK reactor core (Figs. 1 and 2) is cylindrical in shape, its equivalent diameter is 11.8 m, its height is 7 m, the thickness of the side reflector is 1 m and the thickness of the top and bottom reflector is 0.5 m. The reactor core consists of the fuel rods, the moderator, the coolant, the process tubes and the control rods. The graphite pile has 2,488 square rods with a cross-sectional area of  $250 \times 250 \text{ mm}^2$ . The density of the graphite is  $1.65 \text{ g/cm}^3$ . The square rod has a 114 mm diameter round hole (graphite channel) to accommodate the process tube. Graphite rods are inserted into the outer four layers of graphite blocks and process tubes are inserted into the channel of the central 1,693 graphite blocks. The process tubes are made of zirconium alloy and is 88 mm in diameter and 4 mm thick. The coolant, nitrogen gas or a mixture of nitrogen and helium, flows through the opening between the graphite channel and the tube to carry away the heat of the graphite pile. The tube contains two fuel assemblies, 3.5 m long each and connected mechanically. The gap between the fuel assemblies is approximately 20 mm. Each fuel assembly consists of 18 fuel rods with a 12 mm diameter weight supporting zirconium rod at the center. The 18 fuel rods are held in position by a zirconium alloy frame ( $15 \times 125 \text{ mm}$ ). The fuel rods have an outer diameter of 13.5 mm and the zirconium tube with a wall thickness of 0.9 mm houses  $\text{UO}_2$  core blocks of 11.5 mm diameter and a density less than  $10.5 \text{ g/cm}^3$ . The concentration of  $^{235}\text{U}$  is 1.8 percent or 2 percent. The space inside the fuel tube wall is filled with a mixture of argon and helium gas and the tube is sealed off by electron beam welding.

The coolant flows from the bottom to the top in the process tube. As water flows upward from the bottom of the reactor core and reaches a height of 2.5 meters, it is heated to the saturation temperature. Boiling takes place from here onward and at the reactor core outlet the average steam content in the water is 14.5 percent.

The channels for the monitor system and the control system are identical to the channels for the process tube and are located in the central part of the square lattice graphite pile. There are a total of 179 channels and they make a  $45^\circ$  angle with the process tube channels. There are four different

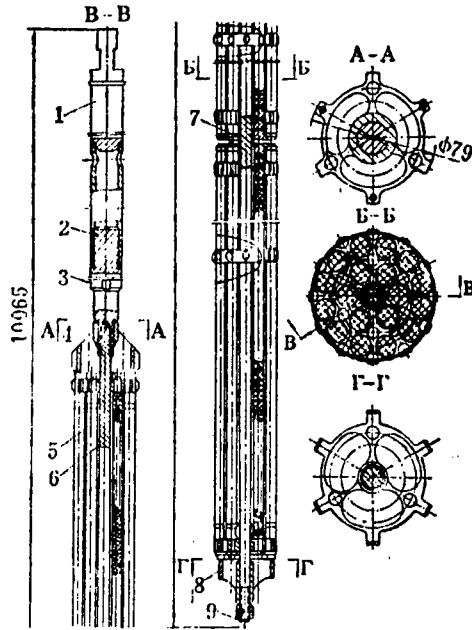

Fig. 1. PbMK Reactor Heat Releasing Element Assembly

Key:

- |                       |                          |                |
|-----------------------|--------------------------|----------------|
| 1. Hanging rod        | 4. Terminal head         | 7. Sleeve tube |
| 2. Cotter pin         | 5. Fuel element          | 8. Tail end    |
| 3. Transition section | 6. Weight supporting rod | 9. Screw nut   |

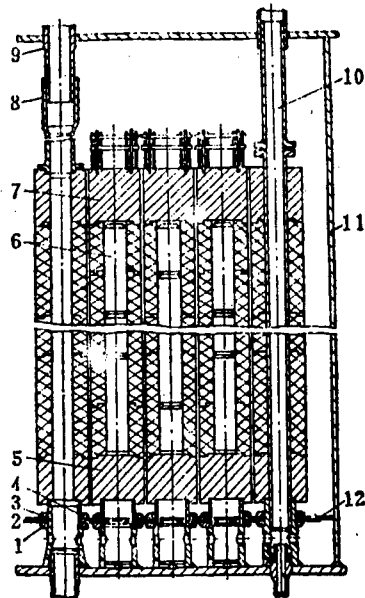

Fig. 2. Graphite Pile

Key:

- |                     |                         |                         |
|---------------------|-------------------------|-------------------------|
| 1. Washer           | 5. Steel support plate  | 9. Guide tube           |
| 2. Separation plate | 6. Graphite plug        | 10. Iron rod            |
| 3. Washer           | 7. Protection top plate | 11. Reactor inner shell |
| 4. Support cup      | 8. Connection sleeve    | 12. Steel ring          |

kinds of control rods: the radial power distribution regulator rod, the power level automatic regulation rod, accident prevention rod and axial power distribution regulator rod. The first three types of control rods move from the top downward and the last type moves from the bottom upward. Like the process tube channels, the control rod channels are also made of zirconium alloy. They have a diameter of 88 mm, a wall thickness of 3 mm and have graphite sleeve on the outside.

#### IV. Graphite Pile

The graphite pile (see Fig. 2) is mounted on a metal structure and weighs 1,700 tons. The graphite blocks have a cross-sectional area of  $250 \times 250 \text{ mm}^2$  and have four different lengths: 200, 300, 500 and 600 mm. Most of the blocks are 600 mm long. Each graphite square rod is mounted on a steel support plate (5) and sits on top of a support cup (4). The top part is fixed to a guide tube (9) coaxially aligned with the graphite square rod. The guide tube is welded to the top metal structure and is connected with the sleeve (8) through the top protection plate (7). The lower separation plate (2) is held fixed on the support cup with washers (1, 3), and the iron rod (10) prevents the graphite blocks from radial displacement. The lower separation plate is a stand-alone steel plate made of 08Cr18Ni10Ti and is 5 mm thick. The gap between the bottom plate and the reactor inner shell (11) is sealed off by a steel ring (12).

#### V. Primary Process Circulation System of the P5MK Reactor

The reactor core of a P5MK graphite boiling water reactor is housed in a  $21.6 \times 21.6 \times 25.5 \text{ m}^3$  concrete well. The graphite pile is cylindrical in shape, surrounded by a steel cylindrical shell, and has metal structures both above and below. To improve the heat conductivity of the graphite and to prevent it from oxidation, the graphite pile is filled with a mixture of helium (40 percent) and nitrogen. The reactor is surrounded by biological shields on the top, at the bottom and on the side. The reactor core has a total of 1,693 process channels and 179 channels for control rods and monitor probes.

The temperature in the primary circulation system of the reactor is  $270^\circ\text{C}$ . Water at a pressure of  $90 \text{ kg/cm}^2$  comes out of the high pressure primary pipe, flows through the regulator valve and the stand pipe and enters the process tube. Water flows from the bottom to the top and carries out the heat. The water is heated to the saturation temperature and is partially vaporized. The average steam content at the reactor core outlet is 14.5 percent. The steam-water mixture flows out of the core and enters the steam-water separator along the primary return circuit. After separation, the steam at a temperature of  $284^\circ\text{C}$  and a pressure of  $70 \text{ kg/cm}^2$  enters the turbine at a rate of 5,400 tons/hour. After the steam condenses and goes through regenerative preheating, it is mixed with the water flowing out of the steam-water separator, it is then pumped into the primary pipe and forced into the main pump high-pressure pipe by the main circulation pump.

The reactor is loaded or unloaded without shutting down. At the normal speed of the fuel loader, 1-2 fuel assemblies can be loaded in 24 hours. The maximum number of fuel assemblies that can be loaded in 24 hours is 5. When the reactor is shut down, some of the fuel assemblies can also be replaced manually for a short period of time.

The monitoring system installed for the reactor processing tubes gives full information on the operating condition of the reactor, the working condition and signals of the control and regulating system are displayed for each process tube. The incidence signal system has the following components:

- (1) Physical monitoring system for radial and axial energy release,
- (2) Process tube leak detection system,
- (3) Monitor system for fuel rod integrity in each process tube,
- (4) Flow rate monitor system for process tube cooling water,
- (5) Temperature monitor system for graphite and metal structures.

The monitor data of these systems are processed by the unit automatic monitor system of the nuclear power plant.

The major parameters of the reactor are:

Thermal power 3,200 MW, average fuel burning depth 18,500 MW.day/ton.  
Electric power 1,000 MW, total coolant flow rate  $3.75 \times 10^3$  ton/hour.  
Height of reactor core 7m, steam flow rate of steam generator 5,468 ton/hour.  
Reactor core diameter 11.8 m, steam pressure in steam-water separator 70 kg/cm<sup>2</sup>.  
Grid separation 250x250 mm, pressure at high pressure collector tube 82.7 kg/cm<sup>2</sup>.  
Number of process tubes 1,693, steam content at outlet of reactor 14.5 percent.  
Fuel enrichment factor 1.8 <sup>235</sup>U, coolant intake temperature 270°C.  
Maximum temperature at specific point in graphite 750°C, coolant outlet temperature 284°C.  
Maximum surface temperature of zirconium process tube 325°C, designed lifetime of reactor 30 years.

## VI. Fuel Assembly

Major operating parameters of fuel assembly are:

Maximum power per tube 3,200 kW,  
Water flow rate in process tube at maximum power 30.5 ton/hour,  
Maximum steam content by weight at assembly outlet 19.6 percent,  
Coolant pressure at assembly intake 79.6 kg/cm<sup>2</sup>,  
Maximum flow rate 18.5 m/sec,  
Maximum outer surface temperature of assembly shroud 295°C,  
Maximum inner surface temperature of assembly shroud 323°C,  
Maximum center temperature of fuel block 2,100°C,  
Maximum fuel consumption 24,000-28,000 MW.d/t UO<sub>2</sub>,

Working time of fuel assembly in the reactor = 1,250-1,700 full power days at 24,000 MW.d/t UO<sub>2</sub>.

The fuel assembly (Fig. 1) consists of the following main components: Two boxes of fuel rod bundles, suspending rod (grabber), terminal head, tailend and central weight supporting rod. The fuel box consists of 18 fuel rods, the grid and the frame. Fuel rods are interchangeable. The grid structure consists of 10 equally spaced grids and a tail grid attached to a central tube. The tail grid is attached to the central tube at the ream.

The fuel assembly has the following geometric dimensions and weight parameters:

Total length	10,065 mm
Maximum diameter	79 mm
Active section	
Maximum length	6,954 mm
Minimum length	6,920 mm
Weight	185 kg
Weight of UO <sub>2</sub>	125-135 kg
Weight of corrosion resistant steel in active section	≤ 1.1 kg
Weight of zirconium alloy in active section	≤ 40 kg.

#### VII. Process Tube Channel

Table 1 shows the operation parameters of the process tube at rated power. If the life of the process tube is described in terms of the integrated neutron flux, then, for neutrons greater than 0.7 MeV in energy, the integrated flux may reach  $3 \times 10^{19}$  neutrons/cm<sup>2</sup>.

Figure 3 shows the structure of the process tube channel. The body of the process tube is a welded structure, the central section is a smooth tube made of Zr + 2.5 percent Nb alloy and has a thickness of 4 mm and a diameter of 88 mm. The top section (3) and the bottom section (11) are stainless steel (08Cr18Ni10Ti) tubes and are welded to the zirconium alloy tube to obtain an absorption cross-section of  $\sigma_a = 0.02-0.03$  barn in the reactor core and to satisfy the following mechanical and corrosion resistance performance at 350°C:

$$\begin{aligned}\sigma_B &> 25 \text{ kg/cm}^2 \quad (\sim 250 \text{ Mbar}) \\ \sigma_{0.2} &17 \text{ kg/cm}^2 \quad (\sim 170 \text{ Mbar}) \\ \delta &= 15 \text{ percent}\end{aligned}$$

The connection between the central zirconium tube and the upper and lower stainless steel tubes is made using a diffusion welding method to achieve a zirconium-steel transition section, see Fig. 4. The main body of the transition section is the zirconium tube and the outer hoop is made of Austenite stainless steel. This welding technique must satisfy thickness requirement and composition requirement in the diffusion zone and the weld must be corrosion resistant in the steam-water mixture and the helium-nitrogen atmosphere.

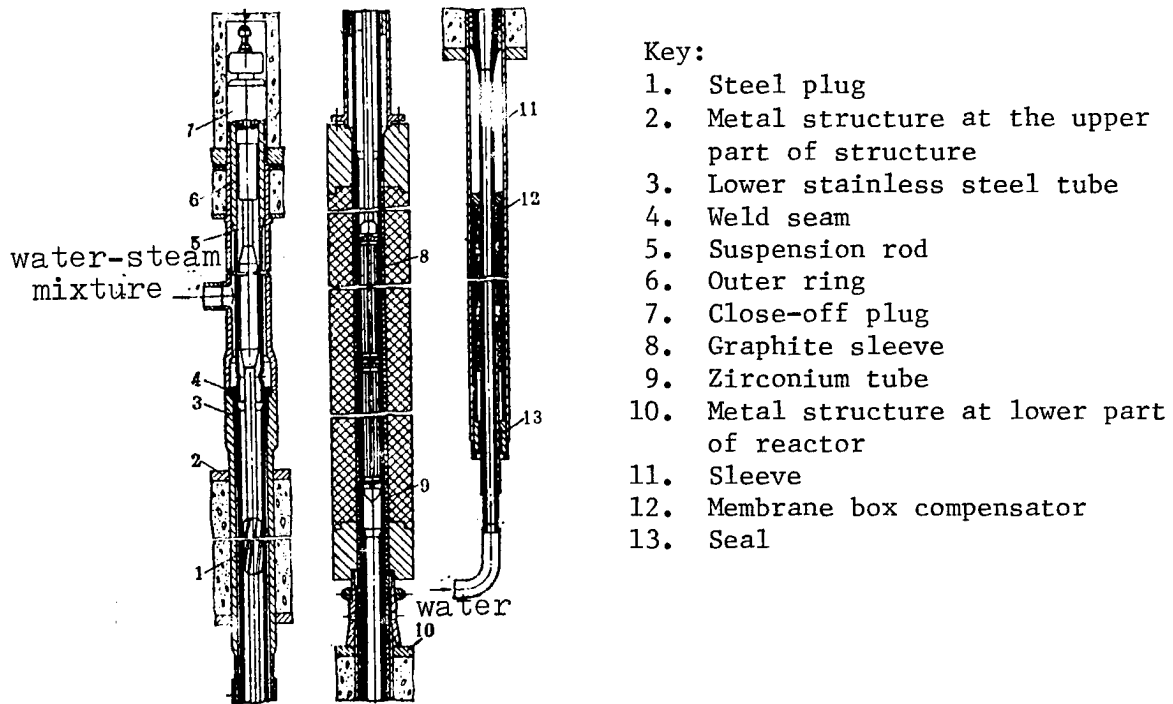

Fig. 3. Structure of the Process Tube Channel

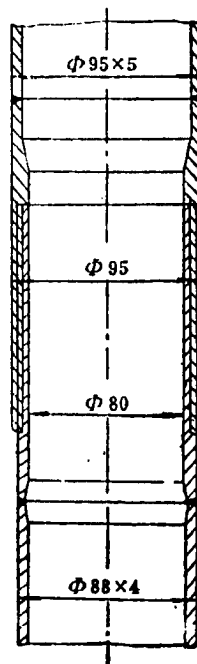

Fig. 4. Steel-zirconium Joint

The zirconium tube of the transition section is then welded to the zirconium process tube and the stainless steel parts are welded to the upper and lower stainless steel tubes. The weld seam and vicinity are then heat treated. The lower part of the process tube then goes through the membrane box compensator (12) and is welded to the guide tube of the metal structure. The outside of the membrane box compensator is then sealed off (13). The designed life of the process tube body is 25-30 years and can be replaced with special tools after the reactor is shut down.

On the upper end of the fuel assembly suspension rod, a close-off plug (7) is installed. It sits within the outer ring (6) and keeps the fuel assembly situated at the reactor core location in the process tube. It allows the refueler to change fuel without shutting down the reactor. A steel plug (1) is installed between the fuel assembly and the close-off plug as a biological shield.

In addition to the process channel, there are also the following channels:

- 179 channels for the control protection system
- 12 channels for energy release monitor probes (laid out axially)
- 4 channels for the start-up of the ionization fission chamber
- 156 channels for reflector coolant

In addition, there are more graphite channels outside the process tube grid for measurement purposes: 8 in the flat zone, 4 in the side reflector and 8 in the support and upper protection cover. Also outside the process tube grid, there are 24 ionization chamber channels, 20 for operation and 4 for start-up.

The channel structure of the control and protection system (Fig. 5) is identical to that of the (axial) energy release monitor and fission chamber. Their cooling water systems are also identical. The head (4) of the control and protection system channel acts as a guide tube for fixing the execution mechanism and for the entrance of the cooling water. The control and protection system tube, energy release monitor head tube and the ionization chamber tube are all "blind" welded to the water system tube with thrust cones. The structure of the lower water supply tube of special channels is different from that of process tubes. It has a lens-shaped compensator (6) and a regulator gate (7) to produce resistance.

The reflector cooling tube (Fig. 6) is mainly used for the cooling of the side reflection graphite blocks (4). A hold-down iron rod (5) is used to fix the side reflector in place.

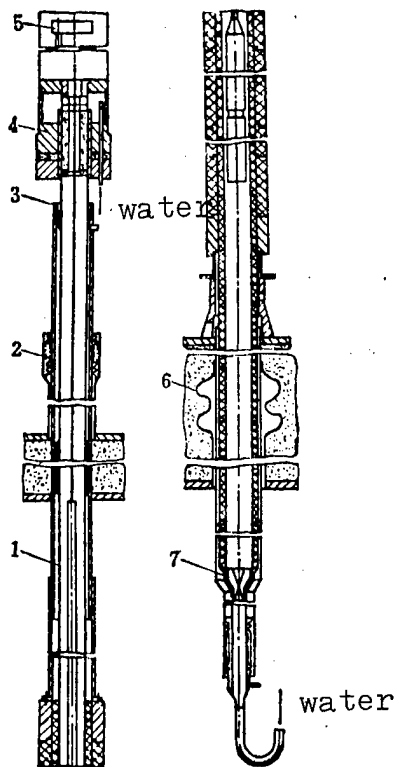

Fig. 5. Control and Protection System Channel

Key:

1. Control and protection system channel
2. Membrane box
3. "Blind" weld seam
4. Head
5. Execution mechanism
6. Compensator
7. Regulator gate

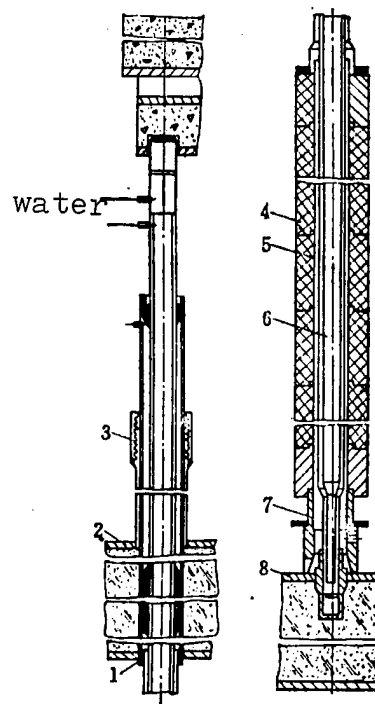

Fig. 6. Reflector Cooling Channel

Key:

1. Upper water system sleeve
2. Upper metal structure
3. Membrane box compensator
4. Side reflector
5. Iron hold-down rod
6. U-shaped pilot tube
7. Support cup
8. Lower metal structure

VIII. Shielding Structure of the Reactor Body

The body of the PBMK reactor is situated in a concrete well (Fig. 7). Shielding materials are steel, serpentine sand, water, structural steel, sand, heavy concrete and ordinary concrete.

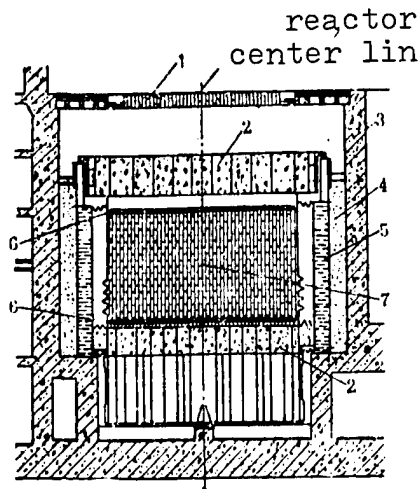

Fig. 7. RBMK Reactor Shield

Key:

- |   |                                   |
|---|-----------------------------------|
| 1. Upper slab (heavy concrete, 4 ton/m <sup>3</sup> ) | 4. Sand (1.3 ton/m <sup>3</sup> ) |
| 2. Serpentine filling (1.7 ton/m <sup>3</sup> )       | 5. Protection water tank          |
| 3. Ordinary concrete (2.3 ton/m <sup>3</sup> )        | 6. Steel protection block         |
|   | 7. Graphite pile                  |

IX. Operation Parameters of the RBMK-1000 Nuclear Power Plant

1. Versatility of operation

Regulation range permitted by load: 50-100 percent of rated power

Rate change permitted by load (percent of rated power per minute)

For 10-70 percent of rated power:	2-3
For 70-100 percent of rated power:	1
Start-up from cold state:	0.3
Start-up from hot state:	1-2
Rate of heating at start-up permitted by heat carrying agent	20°C/hr
Power device start-up time (hours)	
From short period of hot state	3-8
After shutdown	2
From long period of hot state	20
After shutdown	6
From long period of hot state	40-60
After shutdown	12-15
From long period of cold state	40-60
After shutdown	20-24

## 2. Important data during operation

Flow rate of nitrogen or nitrogen-helium mixture passing through the reactor graphite pile	$(8.0-11.0) \times 10^{-2}$ standard $m^3/sec$
Maximum temperature of reactor graphite pile	$< 1,023^\circ K$
Steam pressure in steam-water separator	6.4-6.8 Mbar
Humidity of steam at the outlet of the steam-water separator	$\leq 0.02$ percent
Pressure of fore steam of turbine	6.1-6.5 Mbar
Total steam flow rate of the two turbines	1,500 kg/sec
Temperature of new steam	$553^\circ K$
Pressure in the turbine condenser	$(4.2-4.9) \times 10^{-3}$ Mbar
Feedwater flow rate	$1.5 m^3/sec$
Feedwater temperature	$438^\circ K$

## 3. Water Quality Standard in the Return Circuit Under Normal Operating Conditions

Standard	Return water	Feedwater	Purified condensed water
pH value	6.5-8.0	6.9-7.2	7.0
Concentration (mg/kg)			
Oxygen	--	$\leq 0.02$	$\leq 0.05$
Chlorine	0.1	$\leq 0.04$	$\leq 0.01$
Silicic acid	$\leq 0.5-1.0$	--	--
Hardness (mg equivalent/kg)	$\leq 5$	--	$\leq 0.1$
Specific conductivity ( $10^{-6}$ cm/cm)	$\leq 1.0$	0.1	0.1
Concentration (mg/kg)			
Iron corrosion products	$\leq 0.05$	$\leq 0.005$	$\leq 0.01$
Copper corrosion products	0.02-0.05	$\leq 0.002$	$\leq 0.002$
Sodium	--	--	$\leq 0.003$
Oil content (mg/kg)	$\leq 0.2$	$\leq 0.1$	--
Specific radioactivity (Curie/l) under normal operation	$1 \times 10^{-4} - 2 \times 10^{-5}$		

## X. Development Prospects

In order to improve the technical and economical characteristics of graphite boiling-water reactor nuclear power plants and give them a longer service life and better prospects for development, the Soviet Union further made the following technical improvements based on the consolidated experience of operating

existing graphite boiling-water reactor nuclear power plants for the multiple purpose of reducing the consumption of metal and raw material, reducing the capital construction investment, lowering the cost of power production, shortening the installation time, reducing the number of operators, lowering the dosage of radioactivity, improving the reliability and safety of the nuclear device and improving the versatility of the operation:

(1) In the reactor core design, the heat load and burning depth of the fuel unit have been improved. A reactor nuclear superheating technique was used in the steam supply system to improve the efficiency of the thermodynamic system. The thermal efficiency was increased from 31 percent to 37 percent. Compared with standard steam under the same pressure and producing the same electric power, the superheated steam at 450°C and under 65 kg/cm<sup>2</sup> of pressure can reduce the reactor heat power by 11-12 percent.

(2) The single reactor power was improved. Limited by the pressure vessel manufacture technology and transportation constraints, today's large PWR reactors have stabilized at a single reactor capacity of 1,000-1,300 MWe. Pressurized tube reactors are not subjected to these limitations. The Soviet Union is working on the operation, construction, development and design of a series of graphite boiling-water reactors with electrical powers of 1,000, 1,500, 2,000 and 2,400 MW. The actual operation of the РБМК-1000 reactors has shown that, since the heat engineering safety of critical heat exchange has a certain amount of allowance, heat exchange can be improved while keeping the structure and dimension of the reactor unchanged and thereby raising the power by about 50 percent.

(3) The enrichment of fuel was improved. Physical experiment and calculation have confirmed that the consumption of fuel rods and natural uranium may be reduced by improving the fuel enrichment and burning depth. For example, the consumption of fuel rods may be cut by 20-30 percent if the enrichment is raised from 1.8 percent to 2.0 percent. Calculations also showed that when the enrichment is increased from 1.8 percent to 3.0 percent, the <sup>235</sup>U content in the retired fuel will reach 0.25 percent. If the enrichment is increased from 1.8 percent to 3.6 percent, the <sup>235</sup>U content will reach 0.2 percent [sic]. The <sup>235</sup>U content in the spent fuel has reached the concentration in the tailing of uranium enrichment plants. Raising the fuel enrichment also increases the ratio of nuclear fuel to moderation agent. This causes a change of the steam reactivity coefficient in the reactor and can even change it from positive to negative. This has improved the stability of the reactor power distribution and safety.

(4) The reactor body was constructed by sections. The structure of the reactor body has made the transition from an integral structure to components that can be built section by section. For example the upper and lower steam intake and outlet systems on the reactor body may be built by parts and installed by section. This type of structural layout makes manufacture, transportation and installation easier and reduces the amount of on-site construction and installation. Installation by section is particularly significant in that it does not require great capital construction investments for building special, large architectural and mechanical facilities. In addition, most of the mechanical devices of a graphite boiling water reactor can be built in conventional machine plants.

9698

CSO: 8111/0243

DESIGN FEATURES OF 300 MW PWR POWER STATIONS DESCRIBED

Chongqing HEDONGLI GONGCHENG in Chinese Vol 4 No 4, 1983, pp 1-6

[Article by Pan Xiren [3382 4762 0086] and Zhao Jiarui [6392 0857 3843]:  
"The Main Design Features of 300 MW PWR Power Stations"]

[Excerpts] In this article we briefly discuss the main design features of existing 300 MW pressurized-water reactor power plants in foreign countries and the Qinshan power plant China started to build and compare their performance parameters.

II. Design Features of the Reactor

1. Features of the nuclear design

(1) In order to improve the reactor performance and lower the cost of power production, all the most economic reactors today use the method of zoned fueling according to concentration and zoned refueling in the operating life of the reactor. This method not only reduces the nonuniformity of the nuclear power but also increases the burning depth of the fuel assembly. The average rate of fuel consumption of today's foreign nuclear power plants is 30,000 MWd/tU and maximum consumption may reach 50,000 MWd/tU.

(2) Another important practice for improved fuel utilization is to achieve control by a combination of boric acid solution and control rod assembly. This also facilitates an even power distribution and a simplification of the reactor structure. Today, almost all pressurized-water reactors have adopted this practice.

(3) Most power station reactors have a reactor core neutron flux monitoring system, which monitors the axial and radial neutron flux distribution in the reactor core in the power range of 15-100 percent and thereby monitors the power distribution and nuclear nonuniformity coefficient in the reactor core, insuring a safety margin for the operation. It allows adequate time for the reactor operators to take corrective measures when the reactor core shows power asymmetry, anomaly, and drooping. It also accumulates fuel consumption data for optimum refueling. The use of a neutron flux monitor also greatly improves the safety and the economy of the nuclear power plant.

Table 1. Comparison of Features and Parameters of 300 MW (electric) Power Plants

Station name	Chooz	Obrigheim	Ginna	Bezneou-1	Mihama-1	Qinshan
Country	France	West Germany	United States	Switzerland	Japan	China
Thermal power (in 10 MW)	90.5	105.0	152.0	113.0	103.1	103.5/96.6
O.D./thickness of cladding, mm	9.8/0.38	10.75/0.752	10.72/0.61	10.72/0.65	10.72/0.65	10/0.7
Cladding material	stainless steel		Zirconium-4 alloy			
Fuel rod layout	15x15, 20		14x16, 16			15x15, 20
Active length, m	2.68	2.75	3.048			2.9
Pressure, ata		27 ± 1	20-30			20
Frame material	stainless steel		Inconel-718			GH-169
Number of layers	9	7	8	7	8	8
Type of fuel assembly	Boxed		No box			
Type of control rod	Crossed		Bundled			
Type	Shielded pump	Upright, single-stage, sealed axle eccentric pump (bottom inlet, horizontal outlet)				
Model	K.S.B.	Model 93D 6000 HP	Model 93A 6000 HP	Model 93A 6000 HP	Model 93A 6000 HP	
Design head, m	53	69	77	61	75	
Flow rate, m <sup>3</sup> /h	6020	1450	20400	15900	16100	

[continued]

Table 1. [continued]

Type	Upright U-type	GHH	Inconel-600	Model 33	Upright U-type
Evaporator	Stainless steel				Incoloy-800
Heat transfer tubes	1385	2750	2508.3		2063.7
Heat transfer area per unit, m <sup>2</sup>	282000	320000	496322	2x182000	300000
Design capacity, kw	325000	340000	516739		322000
Calculated capacity, kw	3000	3000	1800	3000	1500
Revolution, rpm	25	21	50	20	30
Shutdown, days	12	11.3	12	12	12
Refueling/ Refueling	12	11.3	12	13	13.47
Annual refuel, ton/year	1961-67	1964-69	1965-70	1965-70	1966-70
Construction period, years					1982-88

The nuclear design of the Qinshan power plant followed the criteria and practices widely adopted by foreign power plants.

Table 2 shows a comparison of the design parameters of Qinshan power plant and foreign power plants of the same type. As can be seen, the reactor specific power designed for Qinshan is almost equivalent to that of similar foreign plants and the nuclear nonuniformity coefficient is even lower than its foreign counterparts.

## 2. The criteria and features of heat engineering design

The general criterion for the heat engineering and hydraulic design of a pressurized-water reactor is that under normal operation no components will be burned out. In the design of foreign reactors this criterion is achieved by requiring the minimum burnout ratio computed from the W-3 critical heat flow density equation to be greater than 1.3. In addition, the heat engineering and hydraulic design will not permit melting at the center of the fuel core. That is, the temperature at the center of the fuel should always be lower than the melting point throughout the lifetime of the fuel.

The main goal a reactor heat engineering design should strive for is a high average power density and a low flow rate. The former allows a greater power output for an equal load of fuel and the latter allows a minimum power consumption of the pump.

The heat engineering design of the reactor is closely related to the nuclear design of the reactor core and the structure of the grids. The main task of the heat engineering and hydraulic design is the proper choice of the operating pressure, the coolant temperatures at the inlet and outlet and the coolant flow rate for optimum technical and economic performance while satisfying the criteria of heat engineering design and taking both nuclear design and structural design into consideration.

Table 3 shows the heat engineering parameters of Qinshan determined after evaluating the various plans. As can be seen, the heat engineering parameters of the Qinshan power plant are roughly comparable to those of foreign 300 MW PMR reactors. The maximum line power density is somewhat lower, which makes the operation even safer.

## 3. Features of the mechanical design

The reactor consists of the reactor core, the interior structure, the pressure vessel and the control rod drive mechanism. In view of the fact that the reactor contains radioactive material, there is strong neutron and  $\gamma$  radiation during operation and the components must operate for long periods of time under high temperatures, high pressures, strong radiation, and the corrosion of water containing boric acid, the reactor must satisfy the following criteria in structural design: All components must have sufficient strength and hardness at the operating temperature, the total deformation of the vessel must be less than 1 percent and it must withstand thermal expansion and water impact while maintaining the structural integrity. The

Table 2. Comparison of Nuclear Design Parameters

Power station name	Chooz	Obrigheim	Ginna	Bezneou-1	Mihama-1	Qinshan
Weight of nuclear fuel, tons	45	35.2	53.3	45.3	40	40.32
Reactor core diameter, m	2.50	2.50	3.45	2.45	2.45	2.486
Reactor core height, m	2.68	2.750	3.660	3.050	3.050	2.900
Concentration, percent 235U	2.93/3.25/3.75	2.5/2.8/3.1	2.44/2.78/3.48	2.4/2.8/3.0	2.27/3.03/3.4	2.4/2.67/3.0
Average consumption, MWd/tU	26000	24000	21800	27000	31500	24570
Control method	cross rod +chemical	bundle rod +chemical	bundle rod +chemical +solid	bundle rod +chemical	bundle rod +chemical +solid	bundle rod +chemical +solid
Total number of control rods (long/short)	30	32	29/4	25/4	29/4	37
Grid distance, mm	13	14.3	14.1	14.1	14.1	13.3
Maximum excess reactivity $k_{eff}$		1.2800	1.2750	1.2700	1.2750	1.2690
Specific power, kw/kg	22.79	30.88	24.38	24.94	25.75	25.40
$F_g$	3.25	3.1	3.28	3.25	3.14	2.90
$F_{\Delta H}$	1.95	1.9	1.75	1.88	1.75	1.67

Table 3. Comparison of Heat Engineering Parameters

Power station name	Chooz	Obrigheim	Ginna	Bezneou-1	Mihama-1	Qinshan
Electric power (gross/net) in 10 MW	32/28.2	34.5/32.8	49.8/47	36.4/35	34/32	32.2/30
Efficiency	29.3	31.15	32.0	32	32	31.1/31.05
Average power density, kw/l	69	76.8	89	78	71	73.5/68.6
Working pressure, ata	141	145	157	157	157	155
Inlet temperature, °C	265	283	289	284	289	287.9/288.8
Outlet temperature, °C	302	312	316	314	317	316.1/315.2
Steam pressure, ata	36	55	51.3	57	55	53.5
Steam temperature, °C	245	264	264	272	270	276.9
Steady state minimum burnout ratio	2.11		2.15	1.94		1.94
Fuel center temperature, °C		1820	2138	2120	2234	2024
Maximum linear power density, kw/m	41.9		54.1	54.3	49.2	43.6

material should be resistant to corrosion and radiation. As there are also stringent requirements on the oxygen, hydrogen, and chloride contents, pH value, and residue in the coolant, the material corrosion rate must be less than 10 mg/dm<sup>2</sup> per month. The heat engineering design also sets requirements on the incident conditions. Under the extreme case of simultaneous occurrence of earthquake and main pipe rupture, the reactor core structure deformation should still permit the insertion of a sufficient number of control rods to shut down the reactor.

The design of fuel rods should limit the vessel stress to less than 0.2 percent of the yield stress at maximum linear heat production (including designed excess power) in the early period of the operation and limit the vessel strain at maximum fuel consumption in the late period of the operation life.

The reactor core is situated below the center of the inlet and outlet connections of the pressure vessel so that in case main pipe rupture causes loss of water the reactor core is still submerged in the coolant. Antifracture support devices are installed at the bottom of the reactor core to prevent the reactor core from falling when the barrel is broken and to limit the axial drop distance so that the control rods in the guide tubes can still be quickly inserted into the core.

Leak detection devices are installed at the seals of the pressure vessel and leak guide tubes are installed between the sealing rings to monitor the temperature and pressure so that small leaks may be guided into the water circulation tank and prompt steps taken for large leaks. Special radiation monitor tubes are installed to monitor the pressure vessel material, material samples are taken out periodically to study changes and to insure the safety of the pressure vessel. To insure the smooth insertion and pulling out of the control rods for emergency shutdown within 1.8-2 seconds, the pressure vessel top cover and holddown device and the opening of the barrel must be accurately aligned and positioned. The pressure vessel is a cylindrical container with spherical or dish-like upper and lower seals. The upper seal may be disassembled and bolted to the cylinder body flange. The dimensions of the pressure vessel are listed in Table 4. The flange surface has "O" ring seals. The design pressure of the vessel is 1.1-1.25 times the working pressure, leaving a large safety margin. Foreign-made vessels have two self-tightening "O" rings, the first "O" ring does the sealing before it fails, and the second self-tightening "O" ring does the sealing after the first one fails. In the design of the Qinshan power plant, the first "O" ring is self-tightening and the second "O" ring is inflatable, based on a different design principle. The control rod drive mechanism is usually of the magnetic lift type. The lowering of the control rods relies on gravity and the raising of the control rods is done by a magnetic suction device. The speed of lowering and raising must meet design requirements so that the control rods may be inserted quickly into the core in case of accident and the design must also be convenient for dismantling and service. The [Robert E.] Ginna, Bezneou-1, and Mihama-1 all have four short rods too control the axial power shift caused by xenon oscillation. It was later realized that long control rods can also control the xenon oscillation. Therefore, most of today's power plants have done away with short control rods. The reactor core is generally equipped with a

Table 4. Design Parameters of the Pressure Vessel

Power station name	Chooz	Obrigheim	Ginna	Bezneou-1	Mihama-1	Qinshan
Material	A336	22NiMoGr37	SA302-B	Carbon steel	SA302 SA508	S271
Innerdiamter, m	3.21	3.29	3.35	3.30	3.30	3.34
Wall thickness, mm	230	160	177	100	229	194
Total height, m	11.2	9.8	11.92	11.7	10.7	10
Net weight, t	216	190		215		230

flux measurement device with a small fission chamber and a self-energy probe. With the exception of the aeroball system in the Obrigheim plant, all other stations use a translational calibration system for the monitor probe.

### III. Main Features of the Power Device

Compared with the power device of other larger PWR power plants, the power device of the 300 MW PWR power plant differs only in the number of main system loops and there are no fundamental differences. The main system of 300 MW - 600 MW power plants generally has two loops (see Fig. 1) but larger power plants may have three or four loops.

Each loop consists of a steam generator and a main circulating pump and is connected to the reactor through main pipes. The G.E. and B&W models use one steam generator and two main circulating pumps.) The main system also has a pressure stabilizer to keep the pressure fluctuation within the normal rated range for steady state and transient operating conditions. The main system also has an over-pressure protection device and a water level controller. Most PWR power plants are designed to track the electric load automatically within a range of 15-100 percent of the rated power and to accommodate  $\pm 5$  percent per minute linear change and  $\pm 10$  percent step change in full power without causing a shutdown or steam release or actuating the pressure-release valve of the pressure stabilizer. When the turbine generator suddenly dumped the load or had an emergency shutdown, the steam release system may discharge 40 percent (or 100 percent) of the steam into the reactor and the primary return circuit so that the reactor will not have an emergency shutdown.

In addition to the main system, a PWR nuclear power plant also has a number of auxiliary systems (see Fig. 1).

According to their functions, auxiliary systems may be divided into the following categories: (1) Systems that insure the normal operation of the reactor and the primary circuit, such as chemical and volume control system, cooling water system, water drainage system, boric acid recovery system, shutdown cooling system and sampling system; (2) Auxiliary systems installed to

- |                    |                                |
|--------------------|--------------------------------|
| 1. Reactor         | 4. Pressure stabilizer         |
| 2. Steam generator | 5. Pressure release tank       |
| 3. Main pump       | 6. Steam release pipe assembly |

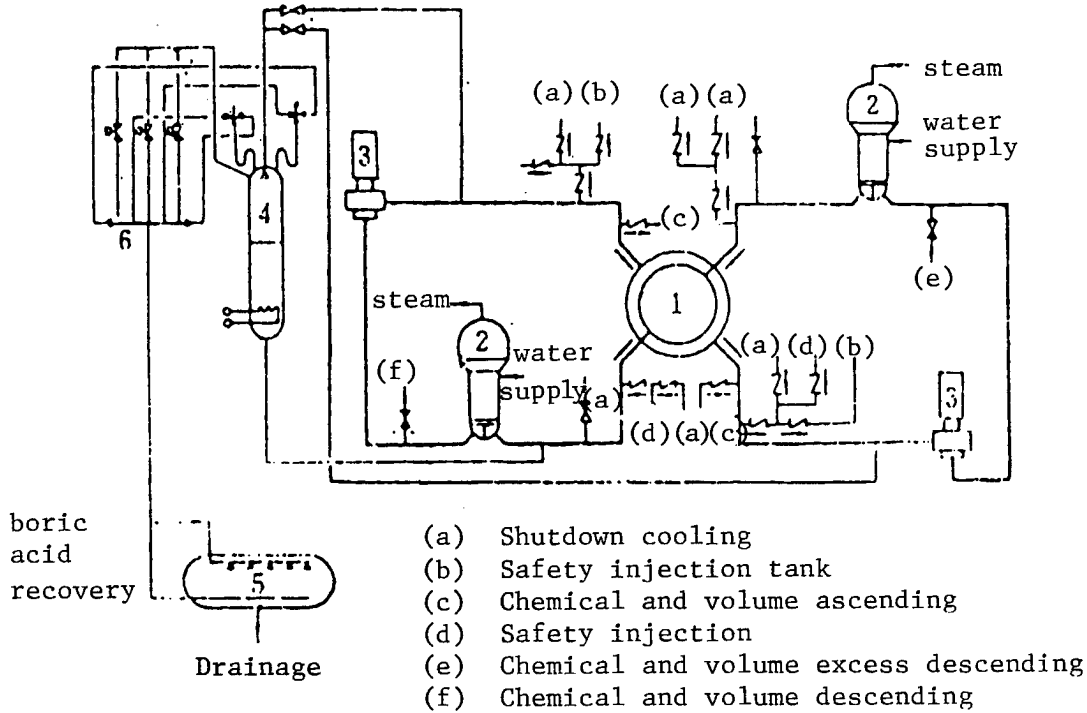

Fig. 1. Primary Return System of a Nuclear Power Station

insure the power station safety and to prevent and contain water-loss incidents in the primary circuit, such as safety injection system, safety sprinkler system, safety vessel circulating air cooling system and hydrogen elimination system; and (3) Waste gas, liquid and solid treatment systems to reduce the amount of radioactive material released into the environment by the power station. In addition, almost all nuclear power stations have safety vessel isolation and fire fighting facilities.

The design principles of several important systems of China's Qinshan nuclear power plant are illustrated in Figs. 2, 3 and 4.

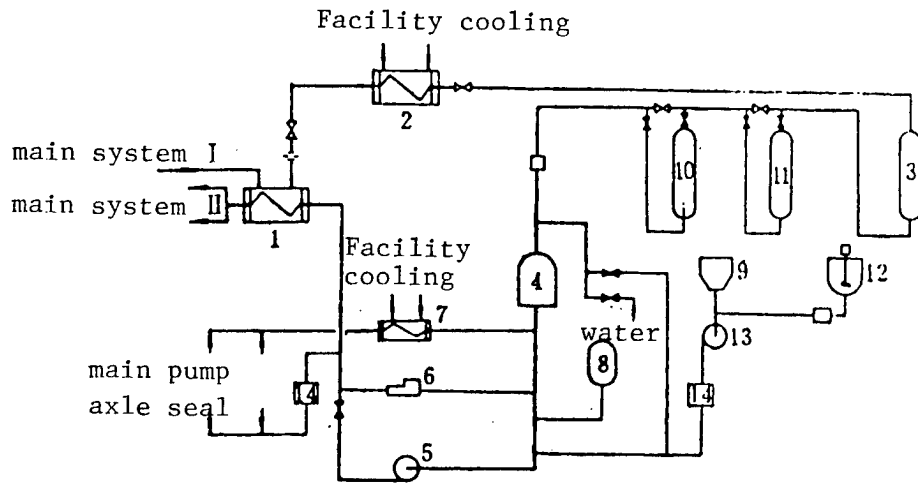

Fig. 2. Chemical and Volume Control System

Key:

- |  |                                    |
|--|------------------------------------|
| 1. Regeneration heat exchanger             | 8. Chemical replenishing tank      |
| 2. Downflow heat exchanger                 | 9. Boric acid storage tank         |
| 3. Purification ion exchanger              | 10. Boron-removing ion exchanger   |
| 4. Volume control tank                     | 11. Lithium-removing ion exchanger |
| 5. Eccentric upflow pump                   | 12. Boric acid generation tank     |
| 6. Reciprocating upflow pump               | 13. Boron acid transport pump      |
| 7. Sealed axle water return heat exchanger | 14. Filter                         |

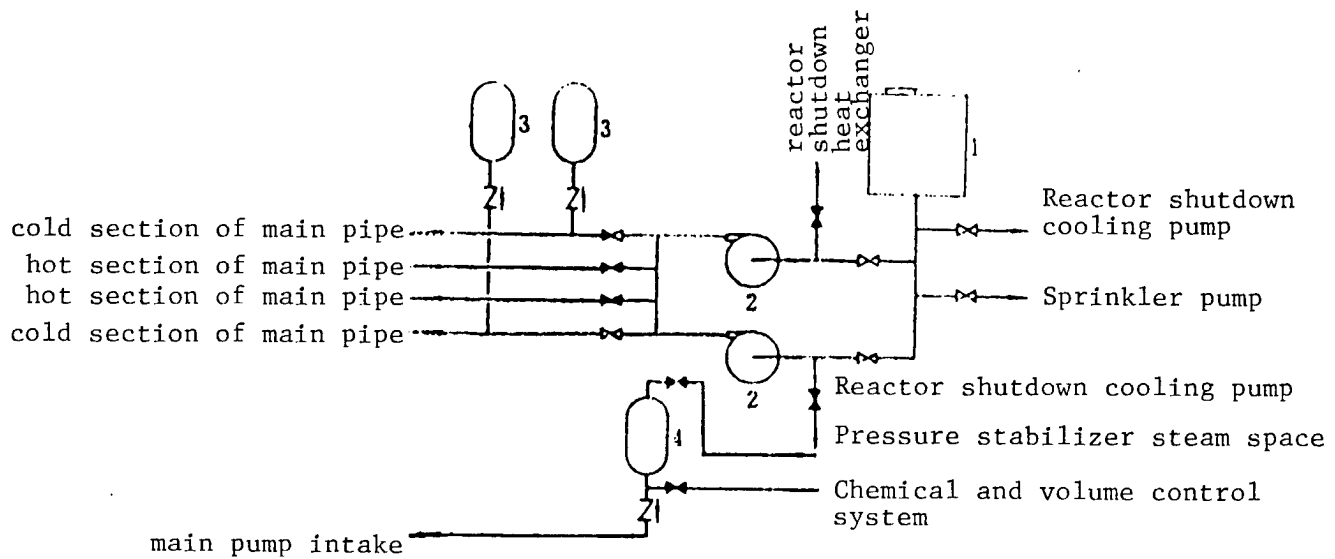

Fig. 3. Safety Injection System

Key:

- |  |                                   |
|--|-----------------------------------|
| 1. Fuel change water tank              | 3. Safety injection tank          |
| 2. High-pressure safety injection pump | 4. Emergency boric acid injection |

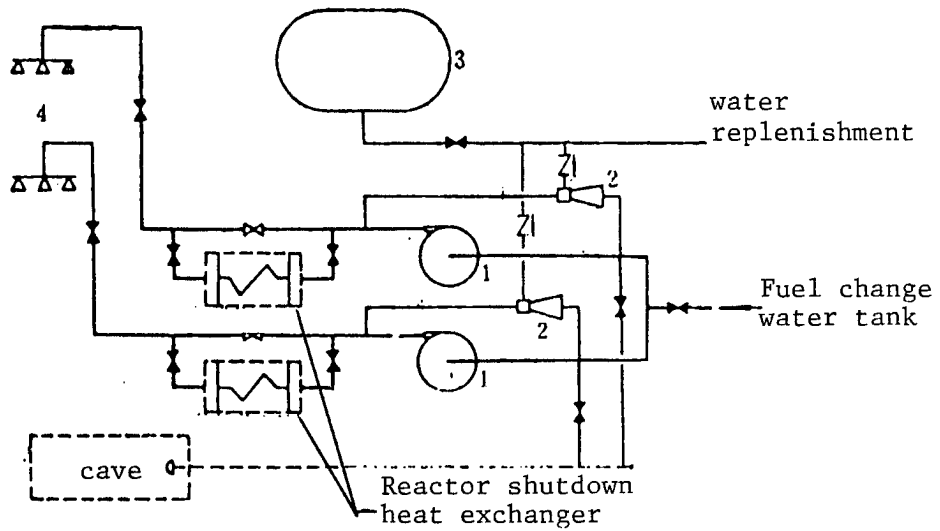

Fig. 4. Safety Sprinkler System

Key:

- 1. Sprinkler pump
- 2. NaOH sprayer

- 3. NaOH storage tank
- 4. Sprinkler head

9698

CSO: 8111/0243

PRIMARY STEAM GENERATOR OF 450 MWt NUCLEAR HEAT SUPPLY PLANT DETAILED

Chongqing HEDONGLI GONGCHENG in Chinese Vol 4 No 4, 1983 pp 7-14

[Article by Gan Jianheng [3927 1696 5899]: "Exploration of the Preliminary Scheme for Primary Steam Generator of 450 MWt Nuclear Heat Supply Plant"]

[Text] This article describes the structural model, tube material, tube supply, and parameter calculations and profile dimensions of the primary steam generator of a 450 MWt nuclear heat supply plant.

I. Introduction

The energy shortage is a critical factor that restricts China's current economic growth. Therefore energy development will be one of China's main emphases in its economic development in the next 20 years.

Due to geographic constraints, some of China's large chemical industries are located far from coal resources, combined with difficulties in transportation, it is difficult to use coal as fuel for power production and for heat supply. Moreover, the quality of certain synthetic fiber products will be seriously degraded if they are contaminated by coal dust. As to petroleum, it is an important raw material for the chemical industry and for export and China's petroleum conservation policy limits its consumption. In comparison, nuclear energy will appear superior.

Since China has not yet started to use nuclear energy in power production and heat supply, people are concerned about the safety of nuclear energy. The safety issue of the primary steam generator is of particular concern because it is not only the steam generating device but also one of the safety guards of the primary circuit system. Besides, some foreign steam generators have frequently suffered from tube rupture. Safety and reliability are therefore the foremost considerations in the design of the primary steam generator. The safety of heat supply nuclear devices in the chemical industry is even more important because the steam produced will be used directly by the operating personnel and residents in the plant area. Once it breaks down, it not only jeopardizes human health but also causes great economic losses during the reactor shutdown.

To insure the safety and reliable operation of the steam generator, we must rigorously control the water quality and the operation and we must also take a number of effective and reliable measures in the structural design by integrating the useful domestic and foreign experiences into the preliminary plan.

## II. Structural Model Selection

Along with the continuous development of the PWR, there are a number of different types of nuclear steam generators today.

In terms of layout, there are upright models and horizontal models. In terms of the circulation of the working material, there are direct flow type and natural circulation type and the latter includes the E model and the D model with an internal preheater and the model 51 without a preheater.

In the preliminary plan we chose the inverted U tube upright steam generator without a preheater for the following reasons:

(1) This model is widely used in China and in foreign countries, the successful manufacture and operating experience will reduce the development cost and production cost and shorten the manufacture period. This choice will facilitate the early completion of the 450 MWt heating supply station.

(2) The reliability of the natural circulation type steam generators with an internal preheater has been poor. The preheater part in particular is apt to suffer damage caused by the hydraulic oscillation in the violent lateral flow and has led to incidences of leaks. For example, the Swedish Ringhals-2 pressurized-water reactor has a Westinghouse D<sub>3</sub> steam generator. On 20 October 1981, its preheater pipe broke under the fatigue caused by hydraulic oscillation and as a result the radioactive water in its primary circuit system leaked through the broken heat exchange tube into the secondary side of the steam generator.

(3) The direct flow type steam generators have a small heat capacity, require stringent control and are more prone to accidents. For example, the Three Mile Island nuclear power plant in the United States used a direct flow steam generator. This type of steam generator has yet to gain wide popularity.

(4) Although the horizontal steam generators are easy to discharge the waste and are safer, but the shear size of it makes the plant layout more difficult. This is the type used by Soviet nuclear power plants but other countries have rarely used the horizontal model.

Based on these reasons, it is appropriate to use the inverted U natural circulation type of upright steam generator.

## III. Tube Material Selection

The selection of tube material for the primary steam generator is an important, fundamental, and complicated task. It has a direct bearing on the safety and reliability of the steam generator. In our preliminary plan we consider using

oCr18Ni9Ti as the heat exchanger tube material. This material gives people the impression that it is susceptible to stress corrosion crack (SCC) damage. So why did we choose this material? The reasons are as follows:

(1) The oCr18Ni9Ti tube material has been successfully used in domestic and foreign steam generators. According to the report of Ref. 1, with the exception of the Soviet Union, 321 stainless steel has been used for heat exchanger tubes in 35 primary steam generators of 11 reactors and 8 steam generators, with a total of 34,746 tubes, without even one broken tube. In particular, none of the 33,216 tubes of the 6 steam generators of Finland's Loviisa-1 reactor in Finland has suffered any damage since its commercial operation began in May 1977. Even more surprisingly, the cooling water in the condenser is not fresh water but salt water and the heat exchanger tubes of the condenser are not made of titanium but rather B 30 brass (70-30 CuNi). This experience is very valuable. As is well known, the heat transfer tubes in Russian reactor steam generators are made of oX18H10T stainless steel. The oCr18Ni9Ti has also been successfully used as heat transfer tube material in Chinese steam generators.

(2) It is appropriate to use oCr18Ni9Ti tubes in the primary steam generator in a water-steam-steam three-circuit system because the most fundamental weakness of the oCr18Ni9Ti stainless steel tube is its susceptibility to stress corrosion crack. There are two reasons for this kind of damage: first, the tubes themselves may have residual stress caused by assembly and welding, and second, the medium may contain a certain amount of  $Cl^{-1}$  ion and oxygen ( $O_2$ ). It is of course not easy to avoid and eliminate residual stress completely, but by rigorous control of the water quality, chlorine ion and oxygen content can be reduced. Stress corrosion cracking may be avoided by eliminating or reducing the environment that causes stress corrosion cracking.

It has been decided that the 450 Mwt nuclear heat supply station will adopt the water-steam-steam model. In this scheme the heat carrying medium in the primary circuit is used to heat the working substance on the secondary side of the primary steam generator and produces saturated steam which in turn heats the working substance of the secondary evaporator. The saturated steam produced by the secondary evaporator is then used to supply heat to the user.

Since the primary steam generator is located between the primary and the secondary circuits, the heat transfer tubes generally do not come in contact with the cooling water of the condenser (salt water or fresh water). This helps to avoid the corrosion by the chlorine-containing water and stress corrosion cracking may be avoided by rigorous water quality control in the system.

Actually, there is no material that is totally immune to stress corrosion and the only difference is the degree. The key is in the water quality control and stringent operation management. Otherwise, the possibility of cracking exists in all material.

(3) Comparison of the new No 13 alloy (Cr25Ni35AlTi) and oCr18Ni9Ti. The biggest advantage of the Cr25Ni35AlTi alloy is that its resistance to stress

corrosion cracking far exceeds that of oCr18Ni9Ti and this was the main purpose for developing this new material. There are three different measured values (by three different groups) of the thermal conductivity of this new material at 300°C: 12.6 kcal/m.hr.°C, 14.4 kcal/m.hr.°C, and 16.2 kcal/m.hr.°C. At 300°C, the thermal conductivity of oCr18Ni9Ti is 16.2 kcal/m.hr.°C. The difference in thermal conductivity has an effect on the heat transfer area. In terms of cost, the new No 13 alloy price is on the high side. A rough estimate shows that the tube material will cost an extra 5 million yuan if all the heat transfer tubes in the primary steam generator of the 450 Mwt heat supply plant are made of the new No 13 alloy. This has to be considered in the cases of small-scale nuclear heat supply plants.

(4) The oCr18Ni9Ti tube material has been in use for a long period of time in China and much experience has been accumulated on the welding, expanding, fillet welding, and heat treatment.

(5) Although the overall characteristics of Incoloy-800 alloy tube material are more superior, but further experiments and research are needed in terms of its engineering properties and heat treatment methods. If the manufacture period is too long, it would unavoidably affect the progress and this material cannot be used at the present time.

Inconel-600 is not a good candidate either, because it has a high rate of cracking and its price is high. In addition, China lacks the experience in its use.

#### IV. Tube Support

Since 1976, indentation has been the major cause for tube cracking. In 1979, 64.4 percent of the tube damages were caused by indentation. The number of plugged tubes caused by indentation has increased from 923 in 1978 to 1,733. The main reason for this phenomenon is the improper structure and material of the support plate.

The tube bundle support plate has a number of patterns including round hole (Fig. 1), grid (Fig. 2), four-leaf (Fig. 3), three-leaf (Fig. 4) and egg-basket (Fig. 5). The round hole plate was originally designed by Westinghouse for its steam generator, the clearance between the support plate hole and the tube is about 0.2 mm. In operation the heat exchange tube touches the hole on one side and causes a nonuniform temperature distribution leading to excessive temperature at the point of contact. Furthermore, since the medium flow is not smooth around the hole, a stagnation zone is formed and salt, corrosion products and oxides tend to accumulate. Because the support plate is made of carbon steel, magnetic materials tend to accumulate in the gap between the tube and the hole (Fig. 6). The accumulated material presses on the tube and deforms it. This is the so-called indentation phenomenon. Further progress of the indentation will crack the tube. The West German-designed steam generators used a grid-patterned support plate, similar to the egg basket plate of Combustion Engineering, Inc. of the United States, which uses a number of narrow, thin strips to support and separate the heat tubes. The grid plate is much better than the round hole plate, it allows an unimpeded

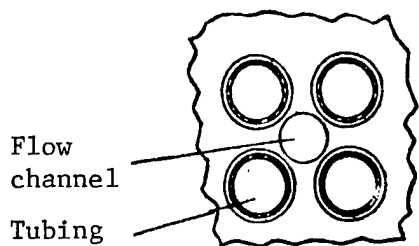

Fig. 1. Round-hole Support Plate

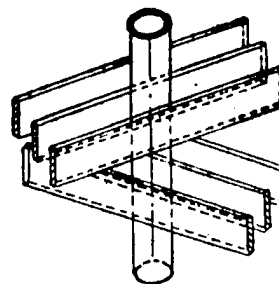

Fig. 2. Grid Pattern

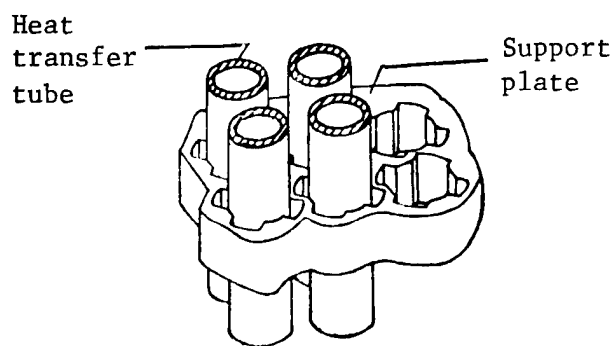

Fig. 3. Four-leaf Pattern

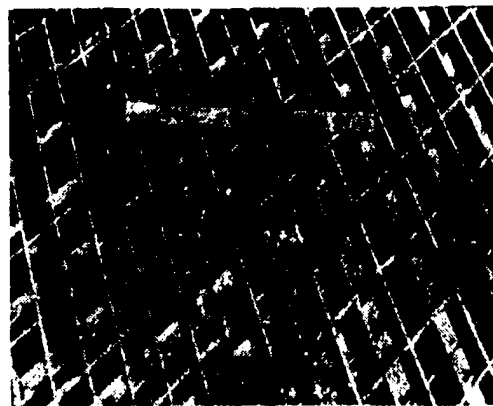

Fig. 5. Egg-basket Support Plate

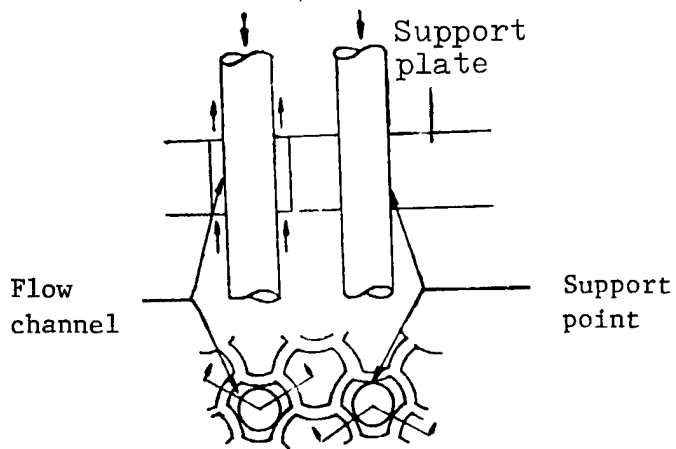

Fig. 4. Three-leaf Pattern

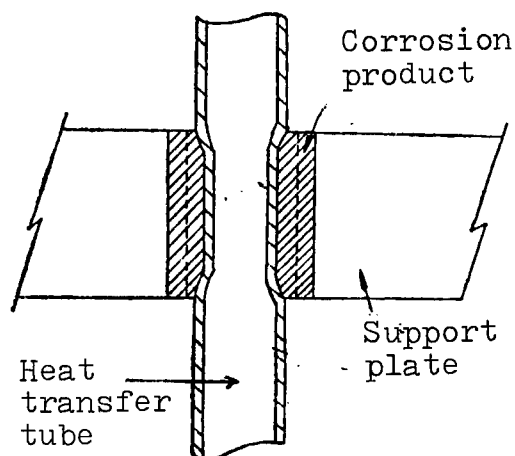

Fig. 6. Indentation Damage Phenomenon

flow of water, has a good resistance to vibration, but requires high precision in its manufacture.

The recently popular three-leaf or four-leaf support plates (the so-called "plum blossom" pattern) have a sensible structure. They allow only three or four contact points between the tube and the support plate, the gap is large, water flows nicely without stagnation and have good heat conduction. We adopted this type of structure in our preliminary design. Chinese plants are already capable of manufacturing this type of structure. The support plate is made of stainless steel.

#### V. Tube Plate Drainage

After the water supply on the secondary side of the natural circulation steam generator mixes with the discharge water of the steam-water separator, it flows downward in the ring-shaped cavity formed between the tube bundle sleeve and the vessel body. At the top of the plate the flow reverses and flows upward through the tube bundle. For large bundle diameter the flow rate is large and the speed as high around the bundle but a stagnation area is formed near the center where the flow rate is small and the speed is low. The distribution of flow rate is very uneven. Near the center of the top part of the plate, corrosion products and phosphates accumulate and form a hemispherical hillock. The sludge accumulated above the tube plate in some steam generators may exceed 400 mm thick. The sludge covers the bottom of the tubes and has extremely poor thermal conductivity. The working substance of the secondary side forms a dry region and a wet region. Above the plate is basically a dry region where the working substance cannot flow and on top of the sludge is the interface of the dry region and the wet region. Under such a condition the bottom of the tubes corrodes quickly.

In order to solve this problem, our preliminary plan calls for a flow distribution plate above the tube plate (see Fig. 7), so that the flow rate is uniform from the center of the tube bundle to the periphery. In the meantime

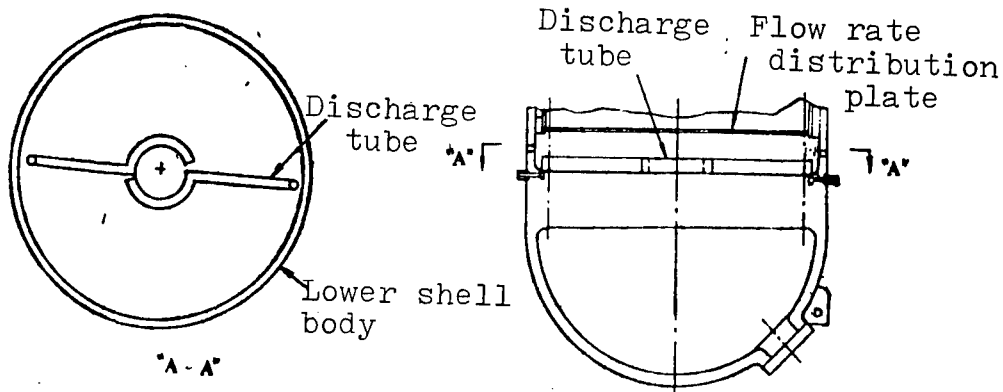

Fig. 7. Flow Rate Distribution Plate and Sludge Discharge Tube

four discharge holes are added to the shell body above the tube plate for periodic cleaning of the sludge on the plate. In addition, a discharge tube is installed on the upper surface of the plate for a better drainage and the discharge of the corrosion products.

#### VI. Steam Pipe Connector

The preliminary design calls for the installation of Venturi regulating holes on the steam outlet pipe connector. The pipe connector and the regulating hole form one integral forged piece (see Fig. 8). This is an important safety emergency measure because in the unlikely event that the main steam pipe of the secondary circuit ruptures, the saturated steam on the secondary side of the steam generator will spray out rapidly and possibly leading to damages of internal components of the steam generator due to the loss of pressure or threatening the safety of the reactor due to the rapid temperature drop of the primary circuit. With the regulating hole just described, the loss rate of the saturated steam will be limited and the above phenomenon will be avoided.

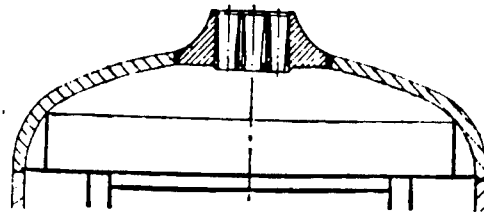

Fig. 8. Steam Pipe Connector

#### VII. Tube Welding

The connection between the tubes and the plate is made by expansion welding. The tube slightly expands along the length of the hole to eliminate the gap

and avoid corrosion in the gap. Also, to prevent the radioactive water in the first circuit from leaking into the second circuit, the welded layers of the tube and the plate are welded together. To facilitate the procedure, fillet welding will be used.

#### VIII. Manhole Seal

There are many forms of manhole seals, such as dentate metal washer seal, "O" ring seal, self-tightening seal and graphite-metal wrapping seal. Our plan uses the graphite-metal wrapping seal. The justifications for this choice are:

- (1) The specific pressure of the dentate metal washer seal is very large. For example, the specific pressure of stainless steel washers is  $Y=710 \text{ kg/cm}^2$ .
- (2) Graphite-metal wrapping seals are reliable and have been widely used in foreign nuclear reactors as well as in chemical engineering facilities in China. The specific pressure  $Y=320 \text{ kg/cm}^2$  only requires about half the tightening force as a metal washer.
- (3) "O" ring seals require a higher and more rigorous precision.

#### IX. Primary Feedwater Loop

An improper opening of the primary feedwater loop on the secondary side of the steam generator may cause severe water hammering. There have been water hammering incidents in foreign facilities. To avoid water hammering, this design discards the method of opening a circular hole below the primary feedwater loop; instead, an "inverted J" tube is welded to the opening above the feedwater loop so that the feedwater flows through the inverted J tube. The openings on the primary feedwater loop are not distributed uniformly along the circumference, more openings are on the hot side (the intake side of the inverted U tube of the steam generator) and less holes on the cold side (the outlet side of the inverted U tube). This arrangement allows a more uniform distribution of the heat flow.

#### X. Parameter Computation

##### 1. Formulae used

- (1) The interior exothermic coefficient of the primary side is computed using the following expressions:

$$N_u = 0.023 R_e^{0.3} P_r^{0.33}$$

$$a_1 = \frac{\lambda}{d} \cdot N_u$$

where  $N_u$  is Nusselt's number,  $R_e$  is Reynold's number,  $P_r$  is Prandtl's number,  $\lambda$  is the thermoconductivity in  $\text{kcal/m.hr.}^\circ\text{C}$  and  $d$  is the inner diameter of the pipe in meters.

(2) The exterior exothermic coefficient of the secondary side is computed using the following expression:

$$a_2 = 3 q^{0.7} P_{II}^{0.2}$$

where  $q$  is the thermal load in  $\text{kcal/m}^2\cdot\text{hr.}$  and  $P_{II}$  is the pressure (in  $\text{kg/cm}^2$ ) on the secondary side.

### (3) Sludge coefficient

Based on domestic and foreign nuclear power station design data, we use  $0.3 \times 10^{-4} \text{m}^2\cdot\text{hr.}^\circ\text{C/kcal.}$

## 2. Computed results

Using the equations above, the following values of thermal resistivity have been obtained (only one set of computation is shown):

Thermal resistivity inside tube	$0.65 \times 10^{-4} \text{m}^2\cdot\text{hr.}^\circ\text{C/kcal}$	28 percent
Thermal resistivity outside tube	$0.17 \times 10^{-4} \text{m}^2\cdot\text{hr.}^\circ\text{C/kcal}$	17 percent
Thermal resistivity of tube wall	$0.96 \times 10^{-4} \text{m}^2\cdot\text{hr.}^\circ\text{C/kcal}$	42 percent
Thermal resistivity of sludge	$0.30 \times 10^{-4} \text{m}^2\cdot\text{hr.}^\circ\text{C/kcal}$	13 percent
Total thermal resistivity	$2.31 \times 10^{-4} \text{m}^2\cdot\text{hr.}^\circ\text{C/kcal}$	100 percent

As can be seen, thermal resistivity due to the tube wall accounts for a rather large percentage. If tube material with a lower thermal conductivity is used, the percentage will be even greater and the heat exchange area will have to be increased.

In addition, since the designed flow speed inside the tube is relatively low, the exothermic coefficient is correspondingly small. If we were to adopt a scheme of double flow, then, although the exothermic coefficient will be increased, the scheme suffers from the drawback of a more difficult in-service inspection because the added "J"-shaped plate at the lower seal of the steam generator interferes with the runner of the eddy current flow detector and the thermal load distribution will also become more uneven. According to measurement results, the load for the primary flow is 70 percent and the load for the secondary flow is only 30 percent. The rate of the tube damage for the primary flow is substantially increased, a very undesirable feature. Therefore, even though a double flow design may improve the heat transfer coefficient, but the reduced useful life makes it not worthwhile.

## XI. External Dimensions

The preliminary design strived to keep the diameter of the steam generator as small as possible because a smaller diameter not only allows a smaller thickness for the tube plate, vessel body and seals but it also makes the working substance flow speed distribution more uniform on the secondary side.

Preliminary computation results gave the following dimensions: the outer diameter of the lower cylinder body is 2,080 mm, the outer diameter of the upper cylinder body is 2,480 mm, the total height is 11,340 mm, and the ratio of the total height to the lower cylinder diameter is approximately 5.5. These dimensions are compatible and appropriate.

#### REFERENCES

1. O.S. Tatone and R.S. Pathaniat, "Nuclear Safety," 22, 5 (1981)
2. Processings of the nuclear material symposium, [Chinese] Atomic Energy Publishers, 164 (1980)

9698

CSO: 8111/0243

## APPLIED SCIENCES

### NATIONAL ATOMIC AND NUCLEAR S&T APPLICATIONS EXHIBITION HELD IN BEIJING

Beijing HE DIANZIXUE YU TANCE JISHU [NUCLEAR ELECTRONICS AND DETECTION TECHNOLOGY] in Chinese No 6, 1982 pp 62-63

[Article: "A Note on the National Nuclear Science and Technology Applications Exhibition"]

[Text] In order to execute the policy of the party Central Committee and the State Council to shift the emphasis on the development of atomic energy facilities "to serving the national economy," the Chinese Science Association, National Science Committee, Defense Science and Engineering Committee and Ministry of Nuclear Industry jointly held a National Nuclear Science and Technology Applications Exhibition at the Beijing Military Museum from 19 October to 13 November 1983. This was an exhibition to spread knowledge of nuclear science and technology and to expand the accomplishments in the applications of nuclear technology. Over 1,000 research results and products from 28 provinces, cities and autonomous regions and 17 ministries and committees were exhibited. The contents included applications of nuclear technologies in industry, agriculture, health and medicine and everyday living. Most of the accomplishments have already been popularized and utilized, and significant economic benefits have been obtained.

The following is a brief introduction to the nuclear industrial radiation detectors and nuclear medical devices demonstrated at the exhibition.

A nuclear industrial radiation detecting instrument is also called an industrial isotope instrument. It is an industrial automatic detecting instrument which measures on the basis of the mutual interaction between the radiation and materials. Because of its characteristics such as high accuracy and sensitivity, quickness and high efficiency, capability to measure nondestructively without contact and absence of effect due to toxic and corrosive environments, it is able to resolve many difficult problems which cannot be handled by other instruments. Therefore, they are widely used to measure automatically density or concentration in a sealed pipe (with materials flowing continuously) in industries such as metallurgy, mining, chemical, rubber, paper and pulp, plastics, building materials, textiles and tobacco; to measure the level of a high-temperature, high-pressure, high-viscosity, strongly corrosive liquid in a sealed vessel; and to detect automatically the thickness of sheet metal, plastic, rubber, paper and coatings. In addition, detecting instruments capable of measuring other parameters can also be developed.

China began to develop various nuclear industrial radiation detecting instruments in the late fifties. A research and production team, including talents in various aspects of radiation, has already been established. According to incomplete statistics, approximately 1,700 instruments of this type have been developed and produced in the country, with 70 percent of them as level indicators and the others as densimeters, thickness gauges and neutron moisture content meters. According to reports, in the area of measuring thickness, level and density, the economic benefit of each instrument is \$3,000-5,000 each year in the Western countries. After the Capital Steel Corporation began to use neutron moisture detectors to measure the water content in coke, the savings in coke alone reached 100,000 yuan per year. After the Harbin Refinery began to use a level indicator, the recovery rate of crude increased by approximately 5 percent. The increase of the recovery rate by 1 percent could bring a daily profit of approximately 6,000 yuan for the refinery. After the Zhengzhou Aluminum plant used an ore pulp densimeter to measure automatically the liquid to solid ratio, incidents of flow blockage were avoided. The liquid to solid ratio was lowered by 0.3. The savings in soda ash in a year were equivalent to 110,000 yuan. After the Dalian Chemical Plant used a X-ray level indicator, the net profit for each furnace increased by 210,000 yuan per year. These examples fully demonstrated that nuclear radiation measuring instruments not only are effective in improving the working condition of workers and the quality of the products but can also significantly increase the economic benefits.

The development work on the nuclear industrial radiation measuring instruments with microprocessors has already obtained some preliminary results.

As nuclear medicine spreads out in China, the development and production of nuclear medical devices are also rapidly expanding. The products shown in the exhibition included a camera (graphic), a microprocessor-controlled cardiovascular function analyzer (also called the nuclear stethoscope) which received the second-class accomplishment award in science and technology in Beijing as well as various liquid scintillometers, counters, isotope activity meters and chromatographs. Some of the products are popular models, and some come with microprocessors which provide a relatively higher degree of automation. These instruments can meet the needs of measuring various widely used isotopes such as  $^3\text{H}$ ,  $^{14}\text{C}$ ,  $^{32}\text{P}$ ,  $^{125}\text{I}$  and  $^{131}\text{I}$ . They have also contributed to synthetic DNA research. Furthermore, various models of devices to measure the functions of the thyroid gland and kidney were also shown at the exhibition. These domestically made nuclear medicine instruments can basically satisfy the need to develop nuclear medicine in China, in terms of both quality and quantity.

Rapid radioactive isotope checkups were made available in the exhibition for the diagnosis of early stages of liver cancer and of thyroid function and were welcomed by the visitors.

In the science building, a basic knowledge of radiation protection was also introduced. The fact that radiation can be protected and monitored was explained with a lot of information. When people are handling radioactive

materials, it is generally safe as long as the rules are obeyed. Just as Comrade Zhang Ziping [1728 1947 5393] once said: "Nuclear energy is not something to be afraid of. It can be harnessed by science and technology. It should be widely used to benefit the Chinese people."

According to reports, some of the products are to be exhibited in Zhengzhou and Guangzhou after the exhibition is over on 13 November.

12553

CSO: 4008/150

MICROCOMPUTER MULTICHANNEL ANALYZER, MICROCOMPUTER MOSSBAUER SPECTROMETER PASS EVALUATION TESTS

Beijing HE DIANZIXUE YU TANCE JISHU [NUCLEAR ELECTRONICS AND DETECTION TECHNOLOGY] in Chinese No 6, 1982 p 63

[Article by Zhang Baukang [1728 0202 1600]: "Microcomputer Multichannel Analyzer and Microcomputer Mossbauer Spectrometer Pass Evaluation Tests at the Ministry Level"]

[Text] The ministry-level evaluation meeting for the Model 1920 (also called the DD80) microcomputer multichannel analyzer and Model FH 1918 microcomputer Mossbauer spectrometer, jointly developed by the Beijing Nuclear Instrument Plant of the Ministry of Nuclear Industry and by Qinghua University, was held in Beijing by the China Nuclear Device and Equipment Corporation. Over 50 delegates listened to a research and development summary report, a test report from the evaluation group and user reports on the two products mentioned above and believed that the characteristic indicators of these two products were better than the design indicators. The system structure is compact. They are easy to operate with complete capabilities. After operating over long periods of time, the instruments are stable and reliable.

The Model FH 1920 microcomputer multichannel analyzer consists primarily of a Model TRS-80 I microcomputer, analog to digital converters, general interfaces and software. The microcomputer scheme adopted in the development will facilitate its multiple-purpose usage. The users can conveniently use BASIC to develop their own software. Furthermore, it is capable of being upgraded to FORTRAN with magnetic disc drives. The computer is equipped with over 20 special-function keys for a multi-channel analyzer. The general keyboard has the convenience of a specialized one. The signal processing portion uses NIM inserts so that the users may choose them conveniently. The small computer-controlled interfaces designed according to function blocks allow the users to obtain the data on various functions without adding various special interfaces. Furthermore, various data acquisition and common data processing softwares are available for sale to the users. Through advanced linking modes, programs written in two languages can be transferred to the internal memory. This computer can also be hooked up with other computers in multiple channels by an existing software to form a fast data acquisition and processing system. These capabilities make its use very convenient. The

evaluation meeting believed that this computer made the first step in the evolution of multichannel analyzer systems in China. Currently, it has already been produced by the batch.

The Model 1918 microcomputer Mossbauer spectrometer consisted of the micro-computer multichannel analyzer with the special Mossbauer spectrum data processing software and plug-ins such as vibrators and standard nuclear devices. The users indicated that its characteristic indicators are better than the design objectives. It is a more advanced product among this type of product in China. Because of its data processing capability, errors may be avoided. It saves measuring time and data processing costs and was praised by the delegates at the meeting.

12553

CSO: 4008/150

APPLIED SCIENCES

PLANNING SYMPOSIUM FOR MODULAR MACHINE TOOL TRADE HELD IN DALIAN

Dalian ZUHE JICHUANG [MODULAR MACHINE TOOL] in Chinese No 12, 1983 inside cover

[Article by Zhang Xiong [4545 3574]: "Planning Symposium for the Modular Machine Tool Trade Held in Dalian"]

[Text] According to the instructions given by the Bureau of Machine Tool in the Ministry of Mechanical Industry, the center for the modular machine tool trade--Dalian Institute of Modular Machine Tools--held a planning symposium for the modular machine tool trade in Dalian from 2-10 November 1983. The primary content of the meeting was to formulate a plan for the trade. This was a big occasion for the machine tool trade. Those who attended the meeting included over 50 managers, technical leaders and representatives from 23 research, design and production outfits such as the Dalian Institute of the Modular Machine Tool Institute, Beijing Third Machine Tool Factory, Baoding Second Machine Tool Factory, Dalian Machine Tool Factory, Dalian Second Machine Tool Factory, Jiling Modular Machine Tool Factory, Jixi Machine Tool Factory, Shenyang Third Machine Tool Factory, Changsha Machine Tool Factory, Sixth Design Institute of the Ministry of Mechanical Industry, Yuxi Machine Tool Factory, Anyang Machine Tool Factory, Hubei Machine Tool Factory, Wuhan Fifth Machine Tool Factory, Guanghua Modular Machine Tool Factory, Ruijin Machine Tool Factory, Shanghai Tenth Machine Tool Factory, Changzhou Machine Tool Factory, Chuzhou Machine Tool Factory, Hanchuan Machine Tool Factory, Changcheng Machine Tool Factory, Dahe Machine Tool Factory and Chongqing Third Machine Tool Factory. Representatives from user plants such as the Changchun First Motor Vehicle Manufacturing Factory, Shenyang Tractor Factory and Shanghai Diesel Engine Factory were also invited to attend the meeting.

The meeting was presided over by Comrade Wang Yong [3769 6978], a consultant to the Dalian Institute of Modular Machine Tools. Chief En Baogui [1969 1405 6311] of the planning section of the Ministry of Mechanical Industry and Vice Chief Mi Jisuo [4717 4949 4792] of the planning section of the scientific education committee of the city of Dalian also attended to provide guidance. During the meeting, important messages from the central leadership comrades concerning planning were delivered and studied. Assistant head of the Modular Machine Tool Institute, Huang Jianbang [7806 1696 6721], gave a speech on the status and tasks facing the modular machine tool industry. Several engineers

from the modular institute also individually introduced the level of development in the production of modular machine tools abroad, the development of flexible modular machine tools, foreign development of flexible manufacturing systems (FMS) and the technical advances made at the modular institute in recent years. Moreover, reference materials on the technological development of modular machine tools and market predictions were also provided to the delegates. Video recording on the introduction of research and production organizations in the modular machine tool trade, the machine tool product exhibition held by the China Machine Tool Corporation in 1982 and the technological development of industrial robots and of automated, flexible modular machine tools abroad were shown in the meeting. After discussion, the delegates believed that although modular machine tools have been widely used in the mechanical manufacturing trade in the past 30 years with significant development and improvement in terms of both quantity and quality, and although the technology and production capability of the modular machine tool trade was demonstrated in equipping such a large factory as the Second Motor Vehicle Factory in the late sixties, however, there is still a considerable gap between China and other developed industrial nations. In order to change this situation, we must rely primarily on technological advances. Practically feasible plans must be formulated to organize the strength in the trade to make progress. On the basis of the understanding of the technological development policy for the machine tool trade, the policy of technology and equipment and the frameworks of science and technology development in the "Seventh 5-year Program" and by the year 2000, suggestions were drafted with respect to the responsibilities of various outfits in the modular machine tool trade after a detailed discussion. Furthermore, unanimous opinion was reached. The meeting also discussed the modular machine tool standardization work in the "Seventh 5-year Program" and the projection for the 10 years after that, as well as the joint promotion of standardization in the trade by all the outfits. It discussed and passed the modified draft of the rules and organizations of the information network for the modular tool trade. It was decided to establish a system for trade information personnel to exchange research results periodically.

It was decided in the meeting that the delegates should report the contents of the meeting and the responsibilities of each outfit to the relevant leadership. Suggestions made after consultation must be sent to the trade center--Dalian Institute of Modular Machine Tools--by the end of the year to be finalized for submission to higher authorities.

The delegates all considered the meeting a success. The strength in the trade is further organized through planning, which will speed up the development of modular machine tool technology. It will effectively make new contributions to the four modernizations in China.

12553  
CSO: 4008/150

NONDESTRUCTIVE TESTING OF COMPOSITES DISCUSSED

Shanghai WUSUN JIANCE [NONDESTRUCTIVE TESTING] in Chinese No 3, 1983 pp 1-4, 11

[Article by Chen Jimao [7115 4480 2021], Beijing Institute of Aeronautical Manufacturing Technology: "Current State and Prospects of Nondestructive Testing of Composite Materials"]

[Excerpts] Research in Nondestructive Testing

Composites consisting of fiber-reinforced plastics, in which a high-strength, high-modulus, brittle strengthener is uniformly combined with a low-strength, low-modulus, tough base material, have excellent combined properties, and have recently been widely developed and extensively applied. But because of the characteristics of the manufacturing process, assuring product quality has become a key problem.

Only nondestructive testing is the correct method of solving this problem. We can assert that if we do not solve the problem of nondestructive testing, composites will not be able to find extensive application.

Nondestructive testing of composites is a new technology which at present primarily makes use of the methods of nondestructive testing of metals. But because composites have characteristics different from metals and because there is no complete systematic understanding of their failure mechanisms, exclusive use of nondestructive testing methods designed for metals is clearly limited in value and irrational. For example, in most metal structures we know that the main defects we seek are cracks, and if a nondestructive method identifies a defective structure, we can use the basic concepts of fracture mechanics to calculate the expected life of the metal part under use conditions. But what is the main defect in composites? This problem has made the quantitative relationships between defects in composite structures and their strength, fatigue life and other engineering requirements a key link in composite applications research. Only by clarifying these relationships can we define the tasks of nondestructive testing and determine which are the essential characteristics to be tested and which are secondary.

Therefore, we must combine basic research in the applications of composites with research into microscopic failure mechanisms and research in nondestructive testing methods. Only by identifying the defects which actually produce an

effect can we promote the application of composites. This will yield two benefits: first, when we have obtained a knowledge of these defects we will be able to use various treatment and manufacturing techniques to decrease the harm they cause; second, a knowledge of these defects and associated quantitative non-destructive testing technologies will enable us to identify pieces which do not meet engineering requirements.

## Testing Methods

Two rather widely-used nondestructive methods of testing for internal defects of composite structures are ultrasonics and radiography.

### 1. Ultrasonic Testing

The main problem involved in ultrasonic testing of fiber-reinforced plastics is the rather high sound attenuation. Specific measurements have shown that the sound attenuation per unit fiber thickness is proportional to the third or fourth power of the frequency. Therefore, high-frequency ultrasonic waves cannot penetrate fiber-reinforced plastic and their reflections cannot be recorded. Decreasing the frequency lessens attenuation, but a lower frequency does not allow microdefects in thin sheet to be identified. The minimum hole size which can be detected with ultrasound is half the wavelength. When a frequency of 5 MHz is used on fiber-reinforced plastic, the smallest hole diameter which can be detected is 0.3 mm; at the same frequency, it is possible to detect the air-hole content of multiple gaps exceeding 10 microns in diameter.

### 2. Radiography

Because fiber-reinforced plastics are generally of rather low density, they have rather low X-ray absorptivity. As a result, the use of low-voltage (e.g. several tens of kilovolts or a little higher), small focal-spot, beryllium-window soft X-rays is particularly suitable method. The radiographic technique can be used for testing of chips and other external impurities, and is particularly sensitive to metal impurities. For example, X-ray radiographs of test pieces containing tungsten filaments showed that filaments only five microns in diameter could be clearly distinguished in photographs' on radiographic paper, filaments as small as 20 microns in diameter could be distinguished. If resin bounding agents with relatively high X-ray absorption coefficients are used, the technique can also be applied to testing of looseness of resin layers or the presence of air holes. Determination of the air hole content is best done in combination with ultrasonic or other methods. Radiography is not as sensitive as ultrasonics in determining air hole content and cannot give quantitative result, so that it is generally not used. Radiography is also usable for discovering transverse cracks in composites.

### 3. Acoustic Emission Testing

Acoustic emission testing uses dynamic characteristics to identify situations that arise in testing or use and has certain specific advantages. But because of the complexity of the machine used to apply stress during the tests and the diverse nature of the sound emission and interference in the piece being tested,

the method is still in the experimental stage except for use with pressure vessels or composite structures of relatively simple shape and stress state.

#### 4. Laser Holography

Holography primarily uses surface distortion to identify defects in a piece, and accordingly it is suited for determining air holes and delamination close to the surface. Air bubbles, which are an important defect affecting mechanical strength, are difficult to detect unless they produce microdeformations of the surface when under load. Laser holography is rather well suited to testing for bonding defects in dome-shaped areas of fiber-reinforced plastic. But the use of a continuous laser beam requires that the test apparatus have extremely high mechanical stability. When a pulsed laser is used, high power is required and it is also necessary to solve the difficult problem of distinguishing defects amid the complex background pattern. An advantage of laser holography is that it is a non-contact method and requires little surface preparation.

#### 5. Thermal Testing

Composites are generally based on organic materials, so that there is a limited temperature rise of the part during testing, and the temperature difference in defect areas is decreased accordingly; thus thermal testing methods require relatively high sensitivity. The defect identification sensitivity of such methods depends on the heat conductivity of sheet materials and the depth of the defects. The heat conductivity in carbon fibers is about 40 times that of glass, and thus the method is not as sensitive for testing carbon-fiber reinforced plastic as glass-reinforced plastic.

#### 6. Dielectric Constant Testing Methods

The insulating characteristics of composites can be used to determine their dielectric constants and loss angle tangents. Because these characteristics depend on the state of solidification of plastics and the physical properties of the composites, they can be used as a monitoring technique during the solidification process to test the solidification quality of composites. During the solidification cycle, the capacitance and loss angle both change. The change in capacitance is determined by the change in the material's dielectric constant, while the change in the loss angle depends on changes in the viscosity of the resin as it undergoes polymerization during the solidification period. Both of these characteristics reflect the peculiarities of the solidification period and accordingly can be used to determine the extent of solidification. The advantages of the method are best utilized when it is applied to determining the degree of solidification.

#### Prospects

The extensive application of composites is highly dependent on quality assurance. A vigorous effort must be made to combine applications research in composites with research in microscopic failure mechanisms and in nondestructive testing. If a major effort is not made in this area, research and development in composites will be unrealistic and any really extensive application of these new structures will be hindered.

Testing research also involves structural failure mechanisms, and a large amount of experimental work must be done in the relationships of various key types of defects of engineering characteristics.

When fiber-reinforced composite structures are extensively used under complex conditions, there cannot be one universal nondestructive testing method that is usable to solve all problems: a variety of methods must be developed and combined for different purposes. Research in nondestructive testing for composites has not been in existence for long, and at present it primarily uses techniques designed for metals. But in the future, research into the peculiarities of testing methods for composites must be conducted and new ways found in this field.

Acoustic testing will still be a key method among testing processes and techniques, and developing and applying radiography will also be important. Ultrasonic spectrum determination, particularly in combination with state-of-the-art ultrasonic data collection methods, improved high-quality signal processing and characteristic extraction methods, as well as advanced pattern recognition techniques, has extensive prospects in the testing of composites. Progress in this work also depends on microprocessor and computer applications.

Based on the defect peculiarities of composites, we should focus on research in new techniques and methods and on use of new achievements in other areas of science and technology in the search for new methods. We should focus on the manufacture of simulated test pieces, and make large numbers of test pieces with different types of defects and different strengths for use in applied and basic research, experimental research on testing techniques, and data accumulation.

Research in the strength testing of composites will develop rapidly and will be a critical factor in determining the strength of important stress-bearing components and pieces with especially high safety requirements; in addition it will be necessary to accord sufficient importance to research on the testing of dynamic properties of structural components while in use in order to assure operating safety.

In the test equipment field, we must develop automated equipment to satisfy the needs of large-scale production; while not a key matter at present, development of small and light instruments for on-the-spot use must be considered, and attention must be given to series production and compatibility and to technical and economic results.

Research in the drafting of such standards as the scope of testing, defect levels, reference pieces and the like is another area that requires attention.

Figure 1. Program of research in nondestructive testing of composites.

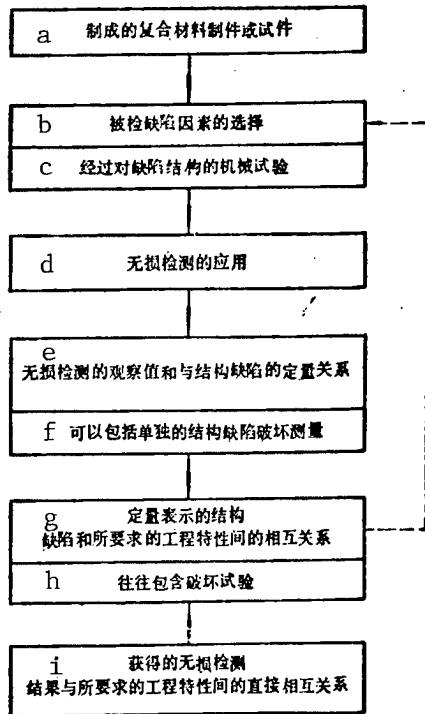

Key:

- a. Ready-made composite products or test pieces
- b. Selection of defect factors to be tested
- c. Mechanical experiments on defect structures
- d. Application to nondestructive testing
- e. Quantitative relationships between observed nondestructive test values and structural defects
- f. Can include failure measurement of individual structural defects
- g. Interrelationships between quantitatively expressed structural defects and required engineering characteristics
- h. Generally including failure tests
- i. Direct interrelationship of nondestructive test results and required engineering characteristics

8480

CSO: 4008/174

END