

Woods Hole Oceanographic Institution

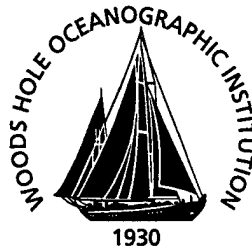

A Deep Sea Docking Station for ODYSSEY Class Autonomous Underwater Vehicles

by

M. F. Bowen, D. B. Peters

June 10, 1998

Technical Report

Funding was provided by the Office of Naval Research under Grant No. N000-14-95-1-1316

Approved for public release; distribution unlimited.

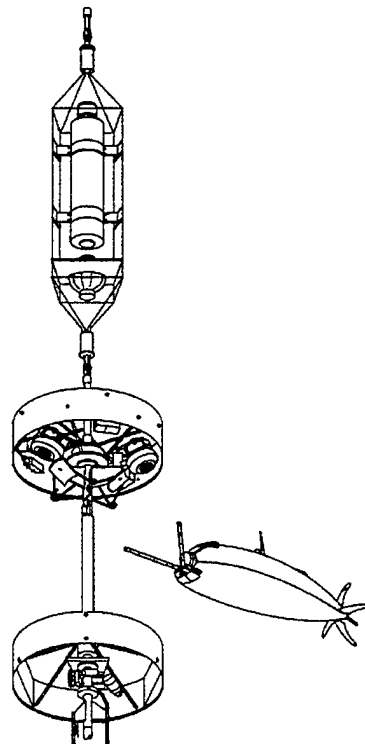

19981103 039

WHOI-98-11

A Deep Sea Docking Station for ODYSSEY Class Autonomous Underwater Vehicles

by

M. F. Bowen, D. B. Peters

Woods Hole Oceanographic Institution
Woods Hole, Massachusetts 02543

June 10, 1998

Technical Report

Funding was provided by the Office of Naval Research under Grant No. N000-14-95-1-1316

Reproduction in whole or in part is permitted for any purpose of the United States Government. This report should be cited as Woods Hole Oceanog. Inst. Tech. Rept., WHOI-98-11

Approved for public release; distribution unlimited.

Approved for Distribution:



Dr. Timothy K. Stanton

Department of Applied Ocean Physics and Engineering

A Deep Sea Docking Station for ODYSSEY Class Autonomous Underwater Vehicles

Electro-Mechanical Design, Fabrication and Operation
for the MIT Sea Grant
Autonomous Ocean Sampling Network (AOSN)

Prepared By:
M. F. Bowen, D. B. Peters



Version 1.0

10 June 1998

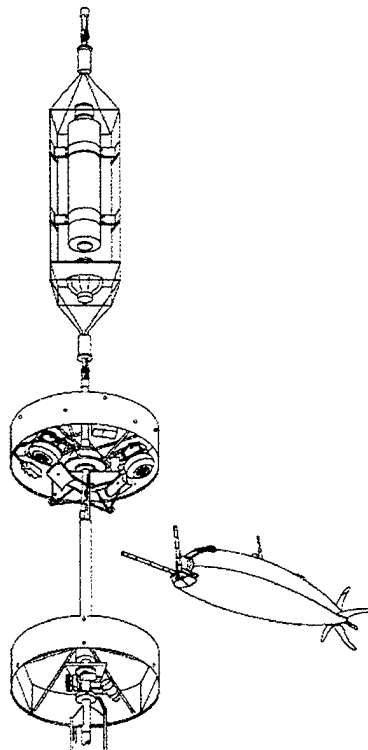

A Deep Sea Docking Station for ODYSSEY Class AUVs

**Electro-Mechanical Design, Fabrication
and Operation
for the MIT Sea Grant
Autonomous Ocean Sampling Network
(AOSN)**

Version 1.0

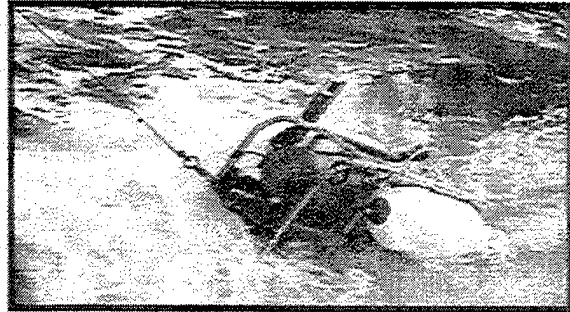

Contents

Abstract	3
1.0 Introduction	4
2.0 Mooring Background	4
3.0 Docking Station	5
3.1 Dock Controller	6
3.1.1 Housing	6
3.1.2 Chassis Layout	6
3.1.3 Chassis Wiring	7
3.1.4 Wet Harnessing	7
3.2 Moving Carriage and Docking Pole	8
3.2.1 Drive Mechanism	8
3.2.2 Guide Aprons	8
3.2.3 Magnetic Switch Harness	9
3.3 Inductive Link	9
3.3.1 Male Core Mounting, Docking Station Side	9
3.3.2 Female Core Mounting, Vehicle Side	10
3.4 Housing Frame	11
3.4.1 Battery Housings	11
3.4.2 External Sensors	11
3.4.2.1 Utility Acoustic Modem (UAM)	11
3.4.2.2 Acoustic Doppler Velocimeter (ADV)	12
3.4.2.3 Seabird RS232 Temperature Probe (SBE)	12
3.4.2.4 Long-baseline Remote Transducer Head (LBL)	12
3.4.2.5 Digiquartz Intelligent Depth Sensor (PARO)	12
3.4.3 Collapsible Flotation	12
3.5 Performance Analysis	13
3.5.1 Moving Carriage Fault	13
3.5.2 Battery Connector Leak	13
3.5.3 LBL Transmitter Fault	14
3.5.4 Carriage Motor Flooding	14
3.6 Proposed Improvements	14
3.6.1 Split Station Modification	15
3.6.2 Pinch Capstan Modification	15
3.6.3 Edgetech Correction	15
3.6.4 Carriage Motor Compensation	15
3.6.5 Slow Scan Video System Addition	15

Figures

Figure [1] AOSN Mooring Components on the Fantail of R/V KNORR	4
Figure [2] Mooring and Docking Station, Block Diagram	5
Figure [3] Docking Station (circled) and 2 AUVs	6
Figure [4] Doccon Chassis, Mechanical Layout	6
Figure [5] Doccon Chassis Wiring (See Drawing 156-97-100)	7
Figure [6] Doccon External Connections and Wet Harnessing	7
Figure [7] Moving Carriage and Docking Pole (shown sideways as stowed)	8
Figure [8] Docking Station, Magnetic Switch Locations	9
Figure [9] Male Inductive Core Mount, Docking Station Side	10
Figure [10] Female Inductive Core Mount, AUV Side	10
Figure [11] Battery Housing, Purgable Endcap, Dock Frame, and Polyform Float	11
Figure [12] Utility Acoustic Modem Housing	12
Figure [13] Acoustic Doppler Velocimeter	12
Figure [14] Collapsible Polyform Flotation	12
Figure [15] Carriage Drive Motor, Housing and Compensation Bladder	14
Figure [16] Proposed Separation of Battery Frame and Docking Pole	15
Figure [17] Odyssey Labrador Sea Mooring Detail, AEL Revision 4	16

Addendums

Dock Controller Chassis Wiring	17-20
Mechanical Drawings	21-68

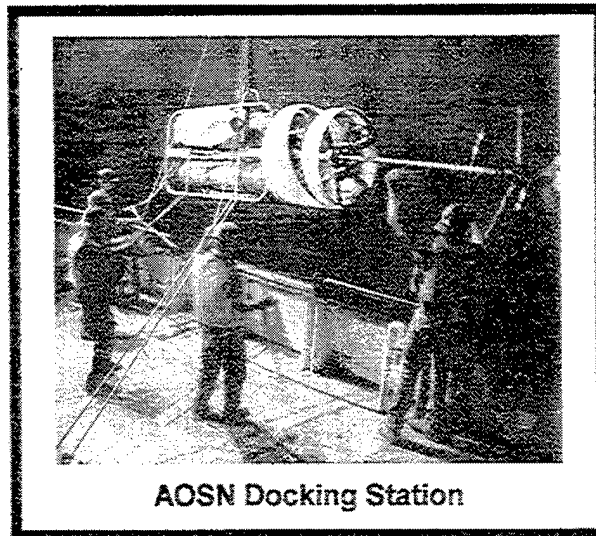

Abstract

Under subcontract to the Massachusetts Institute of Technology's (MIT) Sea Grant Autonomous Ocean Sampling Network (AOSN) program, engineers and researchers at the Woods Hole Oceanographic Institution (WHOI) designed, fabricated and operated a deep sea Docking Station for ODYSSEY-class autonomous underwater vehicles (AUVs). The docking station provides shelter as well as power transfer and data exchange services for an AUV that is between autonomous midwater missions. The Station is integrated into the main tension member of a deep sea mooring system. A large subsea flotation sphere supports the mass of the Station above the seafloor. A surface expression connected by an umbilical to the Station was capable of bi-directional satellite or radio frequency communications. Primary subsystems of the docking Station described in this report include a dock controller with multi-sensor support, long-duration battery packs, a docking pole with a moving carriage, an inductive link for power and data transfer, and information about how the Station was deployed, operated and recovered. (159) Keywords: AUV, docking, mooring.

1.0 Introduction

The AOSN Deep AUV Docking Station was designed and built for MIT Sea Grant by the Deep Submergence Laboratory and the Applied Engineering Laboratory of WHOI and Electronic Design Consultants of North Carolina. The Station was fabricated in the summer of 1997, bench tested, wet tested, deployed to a depth of 500 meters in October 1997 during a test cruise to Site D off the New Jersey coast, revised at WHOI, and retested in preparation for an extended deployment. The Station was sealed and powered up again on 17 January for the (now-completed) 1998 AOSN cruise to the Labrador Sea on the R/V KNORR.

The Docking Station has not experienced a crippling failure since 17 January and has not been powered down since that date. The station was deployed a second time to a depth of 500 meters on 28 January for 14 days in the Labrador Sea and recovered successfully. A minimum of 30 days of on-board battery power has been consumed at the writing of this report.

2.0 Mooring Background

Three major mooring components appear in Figure [1]. The detailed design appears in Figure [24].

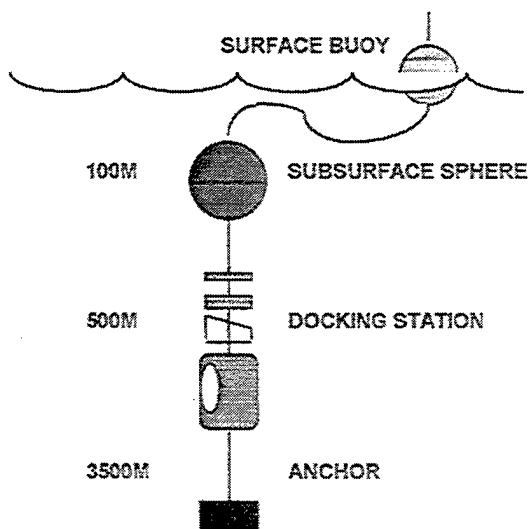

Except for the Docking Station itself, the remainder of the components and hardware making up the Labrador Sea AOSN Mooring have recognized histories of reliability and field longevity. The use of heavy duty strain reliefs, proven electro-mechanical terminations, a compliant s-tether configuration, pull-tested wire rope, new hardware and accurate ballast and buoyancy programs allowed mooring designers at WHOI to provide AOSN with a deep-sea system that was virtually trouble-free on two deep deployment opportunities, one in October 1997 and again this year in the Labrador Sea.

Data to and from the mooring, transmitted via satellite communications, are processed by electronics housed in the surface expression. Data transfer between the surface expression and the Docking Station occurs by a hardwired RS485 link. Data transfer between Station and AUV is accomplished by inductive link and acoustics.

Figure [1] AOSN Mooring Components on the Fantail of R/V KNORR

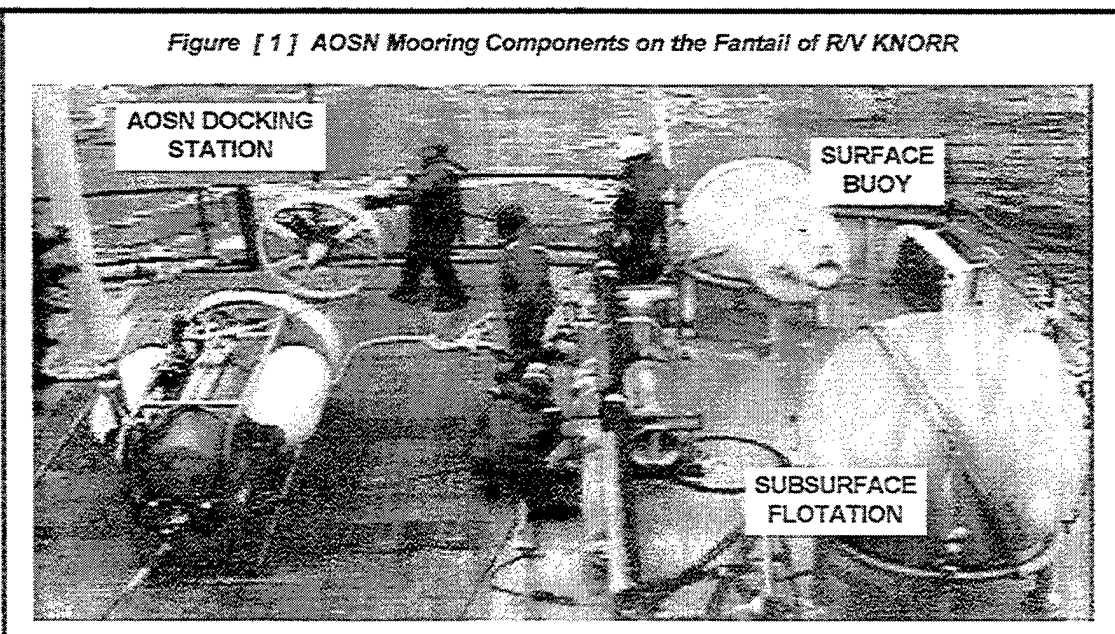

3.0 The Docking Station

A block diagram of the AOSN Labrador Sea Mooring and integral Docking Station appears in Figure [2]. The Docking Station is a tension-bearing device that provides services for an Odyssey class autonomous vehicle between data gathering missions. The Station is also capable of gathering data independent of the vehicle. It can withstand a five-knot mooring deployment transient and static tension through the frame of 3,000 lbs. Its mechanical components consist of a one-atmosphere aluminum frame, two battery housings, a dock controller housing, a docking pole, a moving carriage and motor, external sensors including magnetic switches, collapsible flotation, and wet harnessing. The Station components are pressure tested to 2,000 psig and the complete system is rated to a safe working depth of 1,000 meters. It weighs 2,512 lbs. in air and 930 lbs. at working depth. It is neutrally buoyant at the surface. For testing purposes, the Station can be deployed in water as shallow as 33 meters. A picture of the Station taken during mobilization and being lifted by its side bail appears in Figure [3].

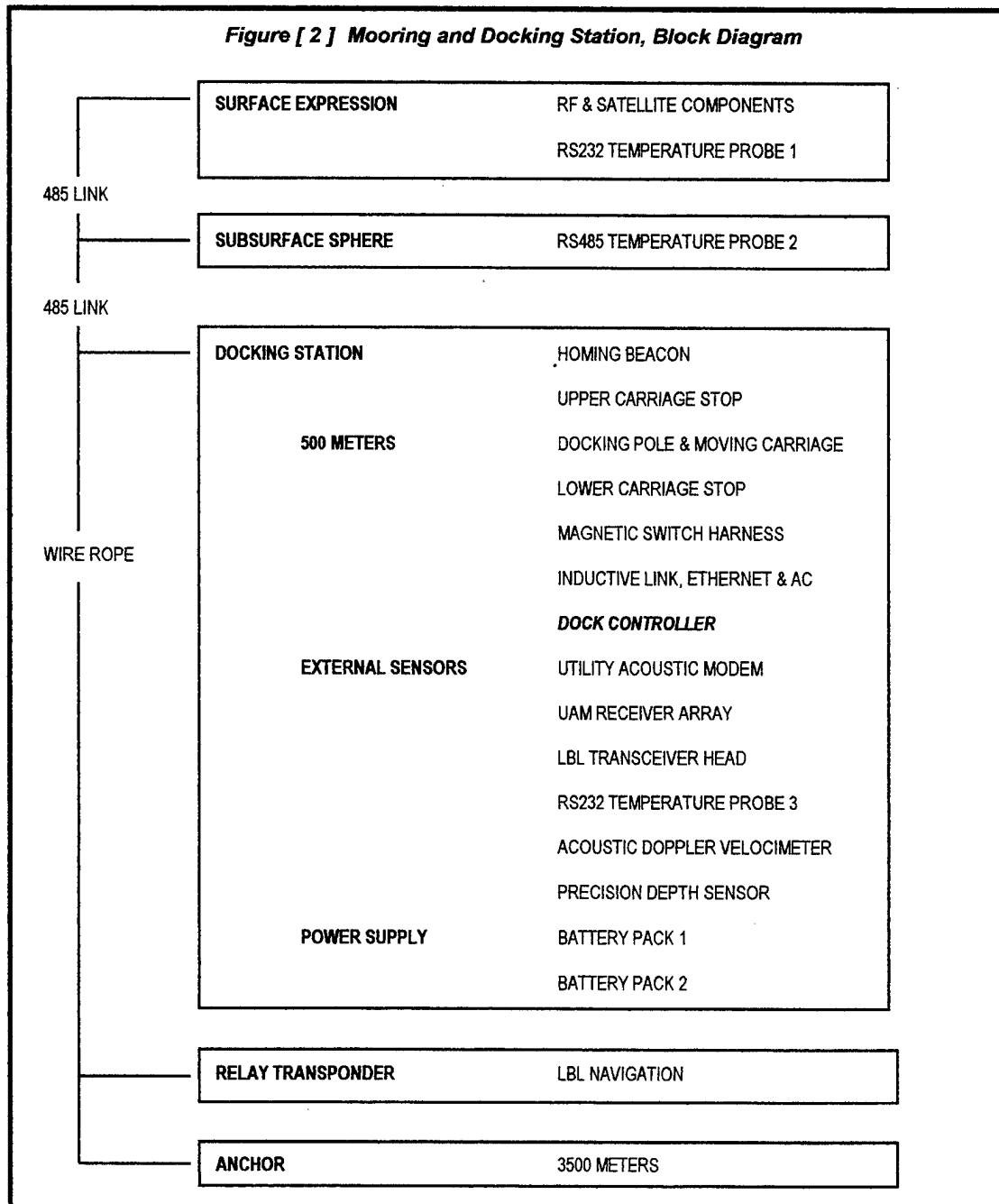
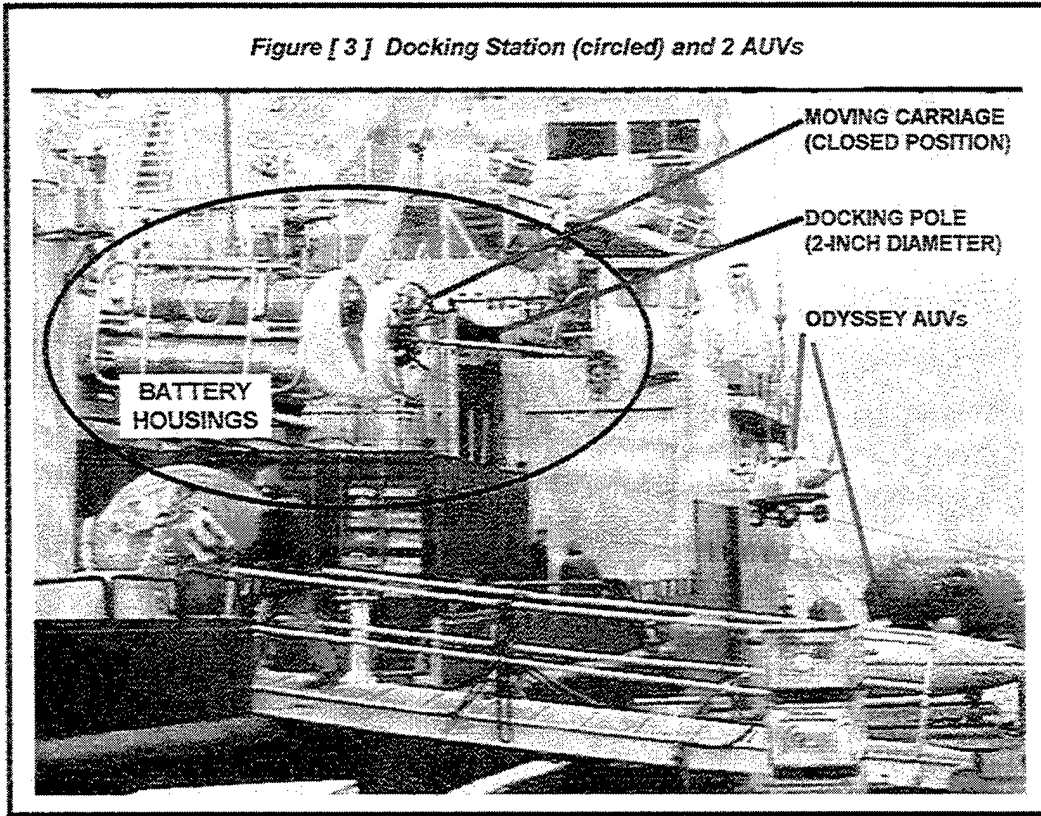

Figure [3] Docking Station (circled) and 2 AUVs



3.1 Docking Station Controller

3.1.1 Housing

The Docking Station Controller (Doccon) is a pressure-proof, cylindrical housing rated to 2,000 psig. The material used for the two endcaps and housing tube is a 6061-T6 aluminum alloy. Other materials used in the construction of the Doccon include Delrin, 300 series stainless steel, and various forms of poly plastics. The aluminum is cathodically protected from corrosion by strategically placed zinc anodes. The housing is nine inches in outside diameter (ten inches with hardware) and fifty-two inches long. It weighs 95 lbs. in air. When sealed, a minimum of ten, ten-gram desiccant packets are added to the volume to ensure humidity control.

3.1.2 Chassis Layout

The Doccon chassis layout appears in Figure [4]. The chassis framework is made up of adjustable aluminum shelves mounted at four corners to perforated aluminum channel. The channel is secured to one endcap only, allowing easy removal of the entire chassis and associated feedthroughs from the housing tube. The chassis is 7.5 inches in diameter. All power conductors are twisted pairs. High voltage circuitry is shielded and/or drained. Craftsmanship in construction meets and exceeds the best commercial practices.

Figure [4] Doccon Chassis, Mechanical Layout

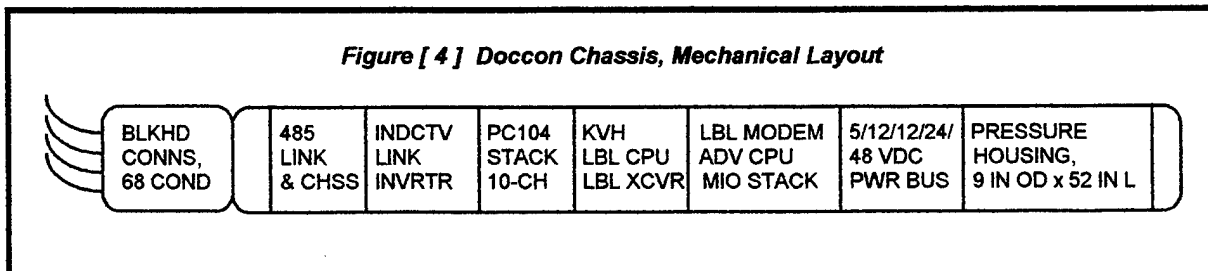
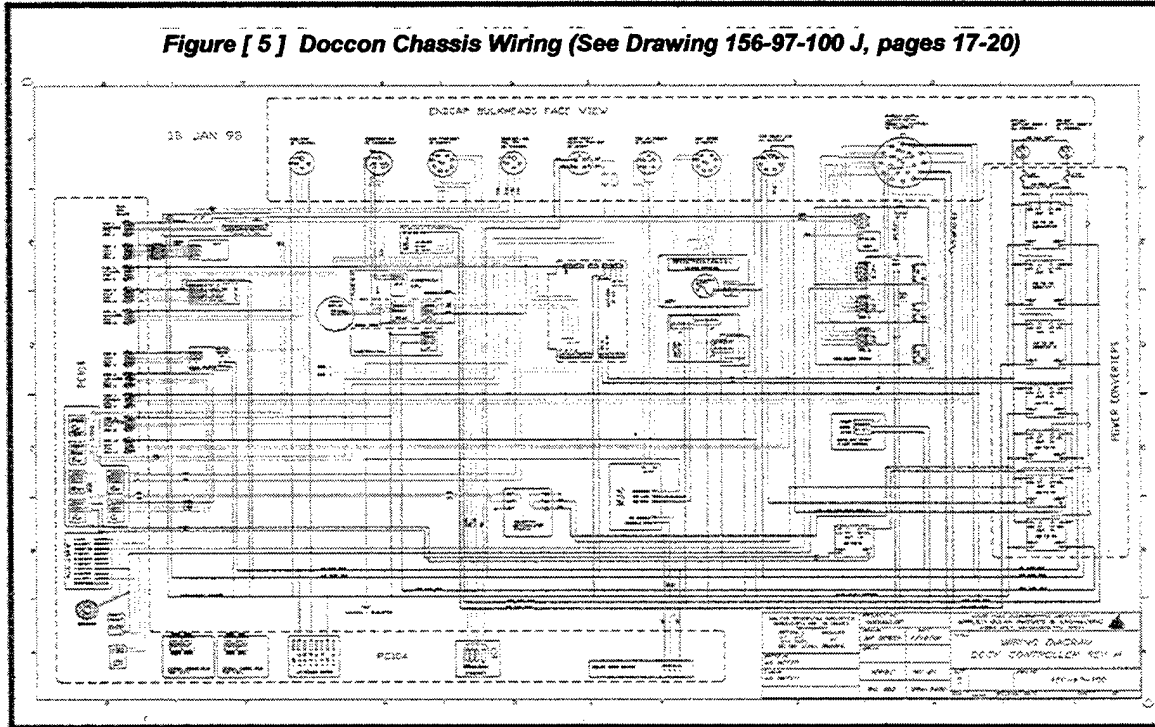

Figure [5] Doccon Chassis Wiring (See Drawing 156-97-100 J, pages 17-20)



3.1.3 Chassis Wiring

The Doccon chassis wiring diagram appears in Figure [5] and as attached Drawing 156-97-100 Rev J. The drawing conveniently details all circuit interconnects, bulkhead feedthroughs, and the design of the power supply buses in a single D-size document.

The Doccon functions as a one-atmosphere enclosure for all integrated electronics associated with the following subsystems: an RS485 to RS232 converter sends and receives signals from the surface expression; an inverter to drive the inductive link resides within an isolated metal chassis; a dc/dc converter supplies the inverter; a PC104 stack with a 80386 CPU and ten serial inputs is assembled with a hard disk drive, parallel port, relay card, video card, Ethernet card, 485 card, utility card, reset circuitry with inverting optoisolator, inverter enabling circuitry; a KVH digital inclinometer with serial output provides dock pitch and roll data; long-baseline navigation and communications is provided by an Edgetech PS8000 transceiver, an AM200 modem, and a transducer driver stack; another circuit card stack supports an acoustic Doppler velocimeter probe; and a three-card stack provides an interface for eight magnetic switch channels and reset I/O signals. Also included in the chassis are sail to RS 232 converter, disabled watchdog circuitry, and a Vicor-based dc/dc converter power supply bus, which consists of eight modules and boosters. The chassis is densely packaged and secured against cable strumming vibration and shocks caused by ship motion and over the side deployment. All of the chassis components have star-point common returns, which float, with respect to seawater. Only the inverter cage and LBL transducer case are grounded to seawater.

3.1.4 Wet Harnessing

A view of the AOSN Doccon external connections and wet harnessing is provided in Figure [6].

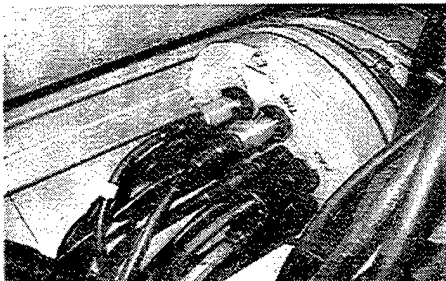

An effort was made to standardize models of pressure-proof connections in procurements from just two manufacturers. We also designed to avoid the pitfalls of interchangeability from bulkhead to bulkhead, which can cause catastrophic inter-connection mishaps. The Doccon feedthrough endcap was designed with a 3x pressure safety margin to help guarantee against deformation and threadlocking. The two endcaps each contain radial and face o-ring seals.

3.2 Moving Carriage and Docking Pole

One and one half meters of a two-inch diameter stainless vertical docking pole are nominally available for the Odyssey AUV to latch onto and be serviced between pre-programmed data gathering missions. The pole has a keyway milled down one side through the dockable length. Inside this keyway rides an alignment key attached to a circular movable carriage. The carriage is designed to force the latched vehicle into a position where the inductive link is mated sufficiently to allow both Ethernet file transfer and power transfer. This is called the docked position. Eight bars of 36.5 lb./cuft syntactic foam provide the carriage with 4.8 lbs. of flotation, making the carriage almost neutrally buoyant in seawater at working depth. Docking pole and moving carriage are labeled in Figure [3]. Another view is shown in Figure [7] below.

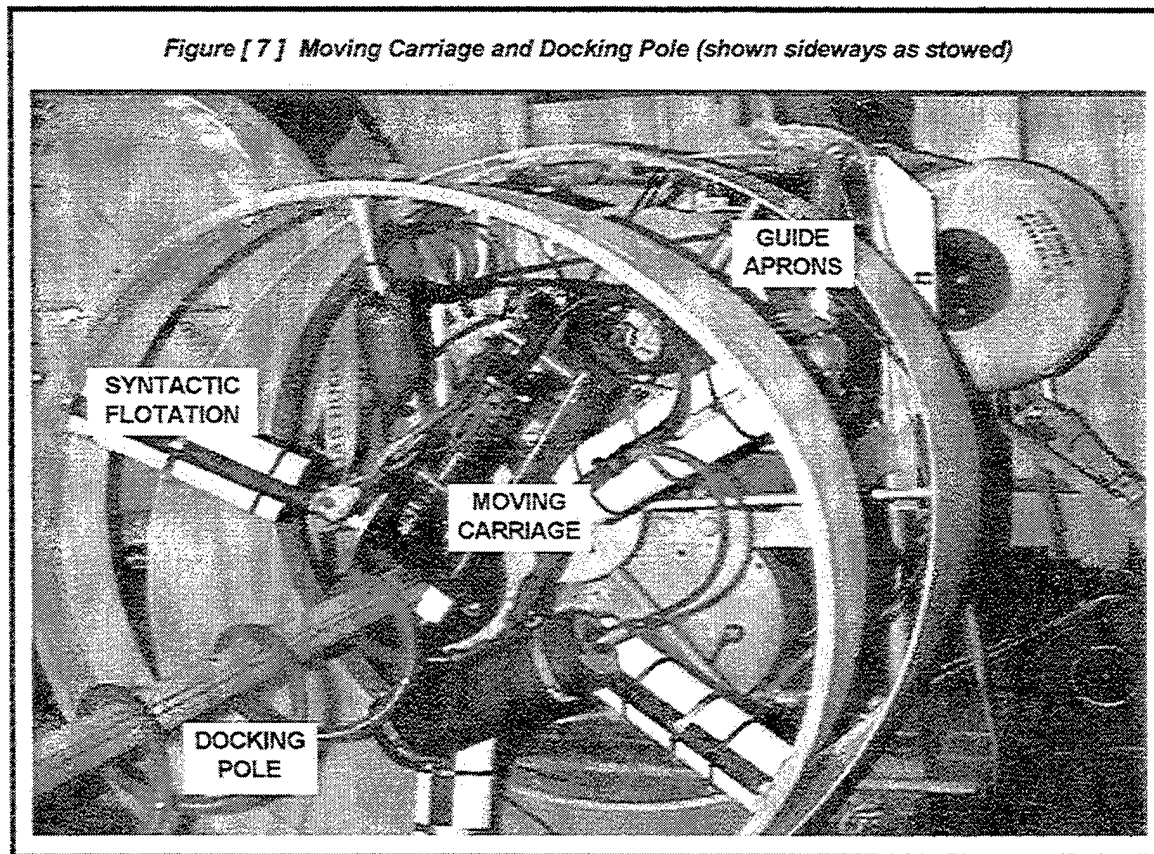

3.2.1 Drive Mechanism

The moving carriage is driven up and down the pole by remote control using a motor, a polyurethane vee-shaped pinch capstan, a Delrin idler wheel and spring tension. The motor is a brushless DC design from WHOI which contains pressure tolerant electronics, hall effect feedback, thermal protection and a 144:1 gearbox enclosed in a 3-inch diameter by 10-inch long plastic housing. The motor, directly coupled to the pinch capstan, is back drivable. The carriage drive mechanism receives 48 VDC and sail commands from the Doccon. It is fused at seven amps.

3.2.2 Guide Aprons

The Docking Station carries two cylindrical guide aprons made of aluminum hubs and polyethylene cylinders, see Figure [7]. One apron is mounted to the moving carriage. The second apron is fixed at the bottom of the docking pole. This apron has a bilateral inclined edge and a saddle cut into it which directs a docking vehicle into the proper position for power and data servicing. A previous version of this scheme supported three possible docked positions instead of the single one present now. One station reduces overall station costs, reduces maintenance, reduces sensing requirements, and increases system reliability. The resilient poly material can withstand glancing collisions by a moving vehicle which may be approaching just high or low of the targeted point of collision at the pole's center. The aprons, the closed carriage and the vehicle latch prevent all six degrees of AUV movement.

3.2.3 Magnetic Switch Harness

An array of eight pressure-proof magnetic switches (normally open) wired in parallel to Doccon MIO circuitry provide topside indications of the moving carriage state and the degree to which the AUV has docked correctly. Two switches indicate the dock is closed to moving vehicles and that the carriage is down. One switch indicates that the carriage is up and the dock is ready to receive a vehicle. After a vehicle has latched and been squeezed into a fully docked position by the moving carriage, five magnetic switches describe the result. Two switches are located in the center of the inductive core; one is a backup. Three switches surround the circumference of the vehicle's hull at the starboard lower quadrant, the port lower quadrant and the center top. Figure [8] shows approximate magnetic switch locations.

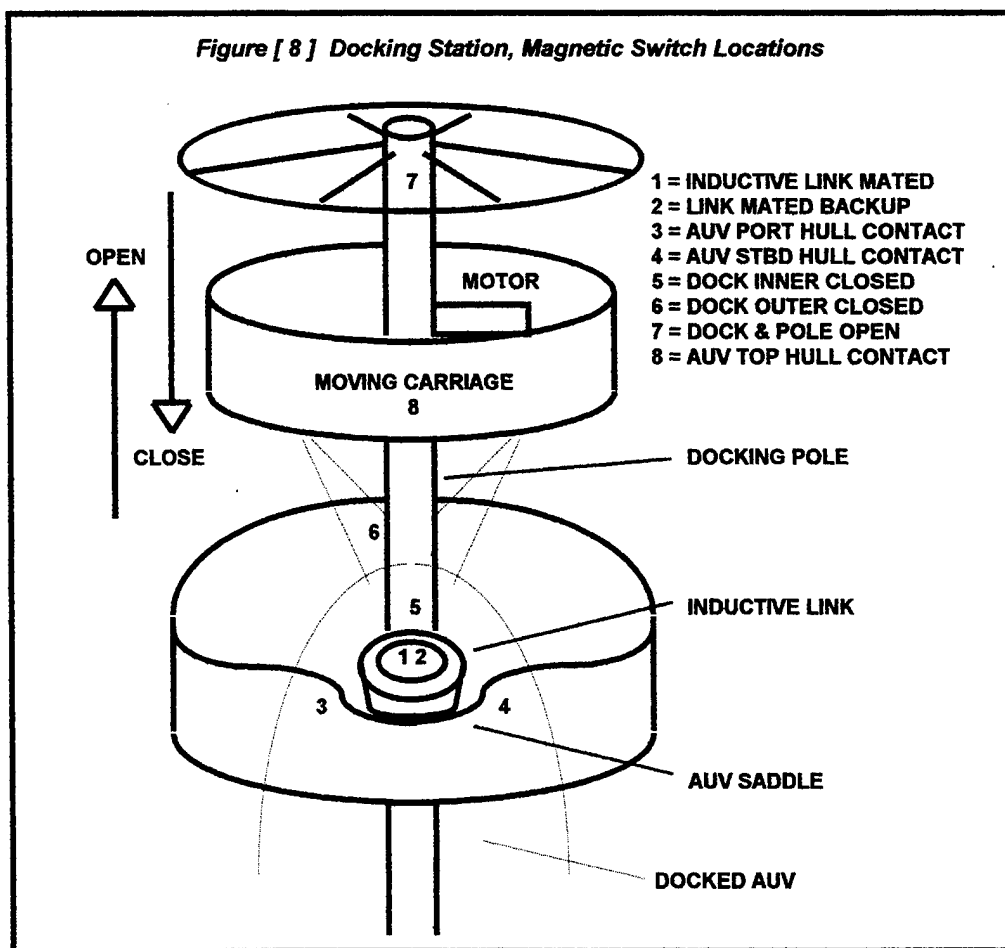

3.3 Inductive Link

The inductive link provides AC power into the vehicle for charging batteries and also provides a half-duplex Ethernet file transfer link. Two cores mate underwater with usually less than one-eighth of an inch between their surfaces. The vehicle carries a female core. The dock carries the mating male core. Both cores contain two epoxy-encapsulated coils for induction; the outer is Ethernet, and the inner is for AC power. (During transit to the operations site in the Labrador Sea a difficult decision was made that eliminated a previously satisfied requirement for power transfer through the Docking Station, however, this did not necessitate alterations, and the ability to induce Ethernet signals through the link was retained.)

3.3.1 Male Core Mounting, Docking Station

The male core is mounted to the Docking Station between the docking pole and the apron saddle. Three threaded stainless rods connect the core mechanically to a six-degree-of-freedom compliant mount. Figure [9] is a close-up image of the male core mounting arrangement. Total compliance of about one-half inch in all directions ensures that the mating cores have the best possible chance of making close contact.

Figure [9] Male Inductive Core Mount, Docking Station Side

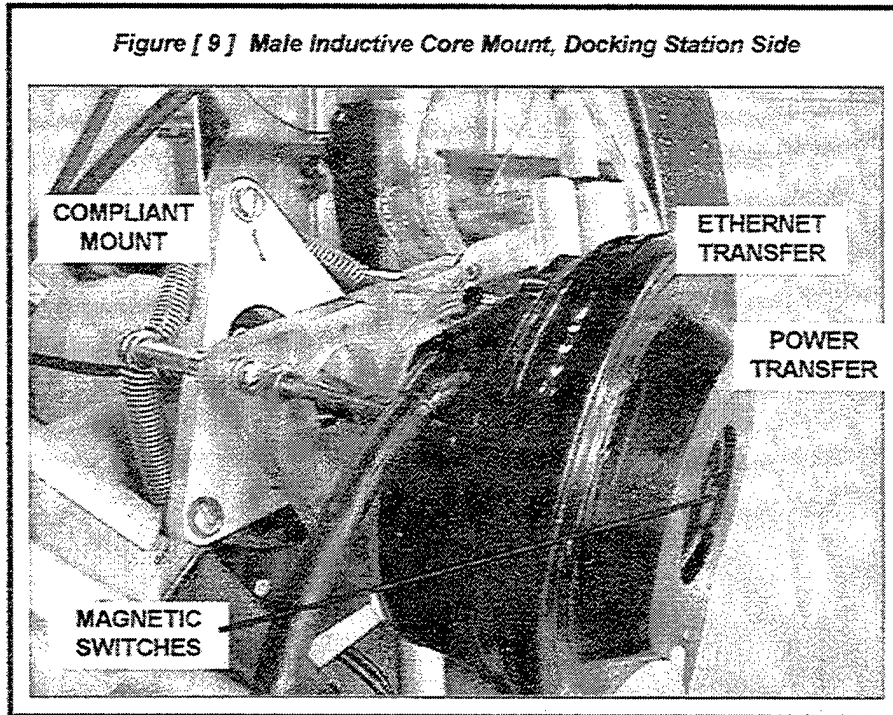

3.3.2 Female Core Mounting, Vehicle

Two female inductive cores are currently mounted to the underside (hull) centerline of two Odyssey AUVs behind the docking latch. Three threaded stainless rods connect the core mechanically to a six-degree-of-freedom compliant mount. Figure [10] is an uplooking image of a female core mounting arrangement. Total compliance of about one-quarter inch in all directions ensures that the mating cores have the best possible chance of making close contact. The female core is slightly more constrained in its alignment compliance due to a space limitation in the bow of the AUVs.

Figure [10] Female Inductive Core Mount, AUV Side

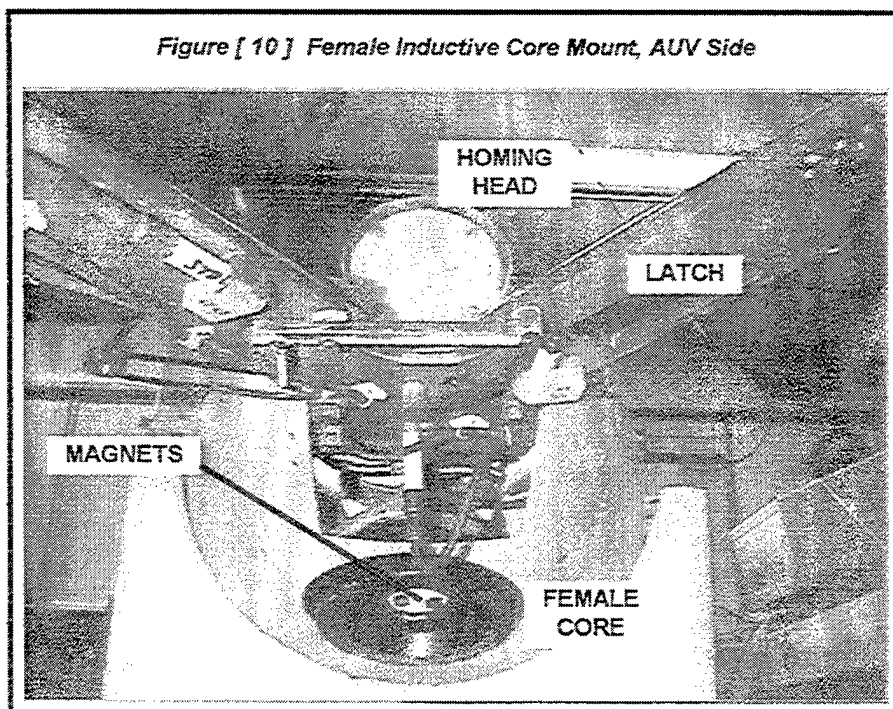

3.4 Housing Frame

The housing frame is a welded and sealed (one-atmosphere), tension-bearing device made of schedule forty 6061-T6 aluminum alloy pipe and fittings. It is an integral part of the mooring and is deployed to a depth of 500 meters when the mooring is paid out. The frame contains brackets and mounting hardware that support two large battery housings, the Doccon housing, wet harnassing, external sensors and collapsible flotation. It has a mooring termination at the bottom end. An adjustable lifting bail (yellow paint, see also Figure [12]) allows operators to move the entire Station from a single pick point whereby the assembled unit is balanced in air. At the top end the frame is bolted to the Docking Station pole. Eight rudder anodes protect the frame from corrosion. The housing frame and battery housings appear in Figures [2], [3] and [11].

3.4.1 Battery Housings

4,960 alkaline D-cells provide a minimum of four months worth of power for the Docking Station components and for vehicle battery bank recharging. The housings provide 65 to 66 VDC nominal output. The D-cells are arranged in pancake packs, stacked and secured inside both battery housings. The packs are diode and fuse protected. Throughout their operational life the housings are cyclically purged of any accumulated explosive gases and resealed with a slight vacuum. The battery assemblies used for the Labrador Sea cruise have been trouble-free. A battery housing, the frame and one polyform float appear in Figure [11].

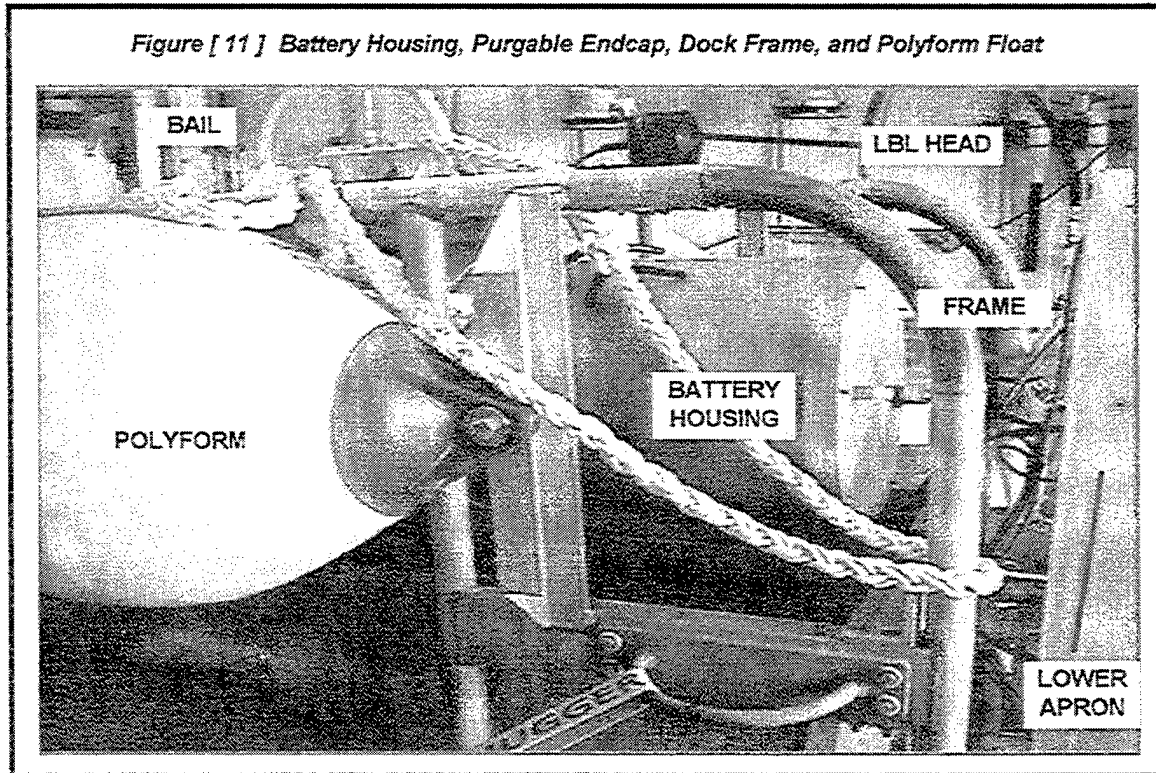

3.4.2 External Sensors

Certain integrated subsystems required that specific components be mounted external to the Doccon. These include the UAM, ADV, SBE, LBL and PARO. ADV and LBL have additional electronics that reside in the Doccon one-atmosphere space. UAM, SBE and PARO provide direct serial outputs to the PC104 computer.

3.4.2.1 Utility Acoustic Modem (UAM)

The WHOI designed and built Utility Acoustic Modem provides 9600 baud cableless communication between the Docking Station and an AUV, and between the Docking Station and a support vessel if either is within one kilometer of the mooring. It consists of: a black-anodized aluminum housing; a four-element receiver array which is mounted to the lower Dock frame; and an optional remote head sound source, which was not deployed on the frame for this cruise. The UAM housing appears in Figure [12].

3.4.2.2 Acoustic Doppler Velocimeter (ADV)

The ADV and probe provide AOSN researchers with precise current measurements in 3D space. The primary ADV electronics reside as a three card stack inside the Doccon. The remote probe was situated so that it pointed away from the body of the Station, and it was mounted at right angles to the axis of the mooring. The probe is fairly delicate, so an effort was made to place it away from Station launch and retrieval tag points. The ADV probe and mount appear in Figure [13].

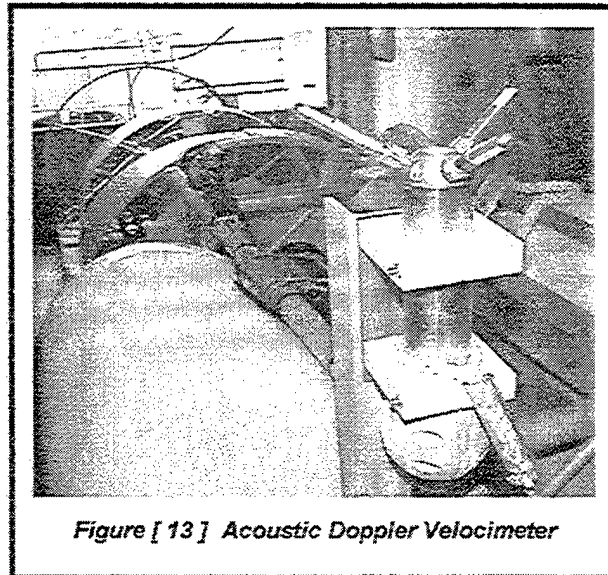
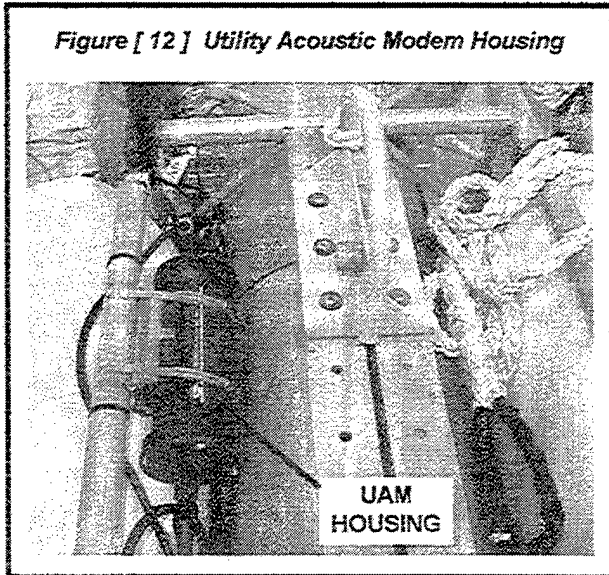

3.4.2.3 Seabird RS232 Temperature Probe (SBE)

This sensor is one of three Seabird sensors on the AOSN mooring. One is powered from and read at the surface expression. A second is mounted on the subsurface flotation sphere and is read via RS485 link at the Doccon. This middle temperature probe is powered by a self-contained alkaline battery pack mounted to the subsurface sphere. The third sensor is mounted to the Docking Station frame. It has a standard RS232 serial output to the PC104 computer inside the Doccon, which also provides it with a nominal 12 VDC.

3.4.2.4 Long-baseline Remote Transducer Head (LBL)

The remote transceiver head for the Edgetech long-baseline navigation system was mounted to the frame near the lifting bail. It appears at the top of Figure [11].

3.4.2.5 Digiquartz Intelligent Depth Sensor (PARO)

A precision Paroscientific depth sensor was mounted to the movable carriage. Data from the sensor relays not only carriage depth but also whether it is moving vertically with respect to the pole when remotely commanded.

3.4.3 Collapsible Flotation

Two large polyform floats were bolted high onto the battery housing frame. When fully inflated, each float provides 465 lbs. of positive buoyancy, see Figure [14] below.

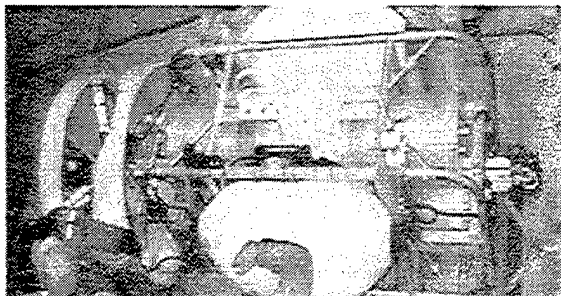

The Docking Station weighs 930 lbs. in seawater. At the sea surface, the two polyforms allow the Station to be neutrally buoyant. This collapsible buoyancy ability increases the chance of deployment without collateral damage, particularly pole bending. As the Station leaves the surface and rotates to become vertical with the axis of the mooring, the polyforms shrink and their influence on the underwater mass is eliminated. One of two floats also appears in Figure [11].

3.5 Performance Analysis

The station experienced four non-crippling faults in subsystems during its first 1998 immersion: the moving carriage became stuck; a battery connector experienced shallow water intrusion; the long-baseline (Edgetech LBL) navigation transmitter failed; and the carriage drive motor flooded during recovery operations.

3.5.1 Moving Carriage Fault

The movable carriage, which aligns a docked AUV into the power transfer position, was stuck in an indeterminate position for the entire deployment. A contingency plan was devised to repair the carriage as soon as the fault became critical to cruise goals. The mooring was recovered after immersion for two weeks for this and other reasons, but was not re-deployed due to constraints of weather and time.

The carriage became unstuck during mooring recovery making fault analysis difficult. An inspection was performed once the system was secured on deck. Our initial impression was that some interference occurred in the pole keyway, however these components had passed all operational tests at WHOI.

The pole was definitely bent during the recovery process while the station barrel-rolled in the water behind the stern and again when it was on the fantail and the rest of the mooring was trailing behind the ship. Conditions were rough. It is possible that the pole was bent earlier, upon deployment, when the dock inverted from a downward slant to an upward slant (see deployment sketch below).

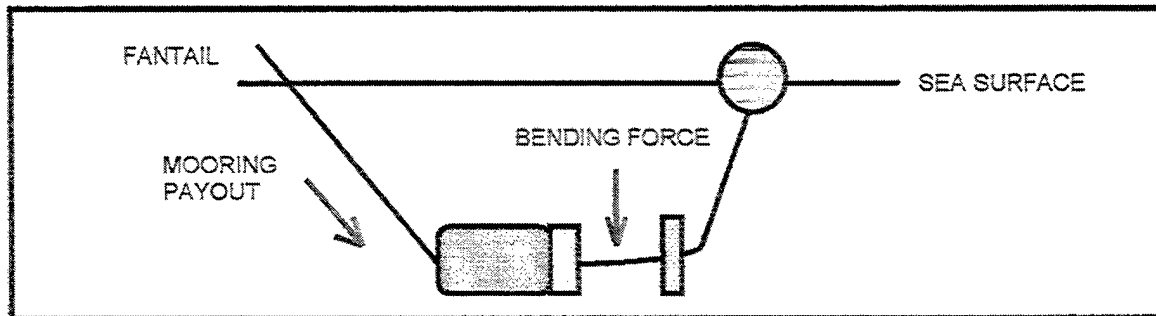

If the pole was bent in this way slightly during deployment then the close tolerance of the moving carriage collar may have interfered with easy sliding on the pole. This theory coincides with depth sensor indications that the carriage was 0.4 meters below the pole center point. In this stuck position none of the three magnetic switches would have been activated.

Mooring tension would not have been sufficient to straighten the pole for normal operations. The moment required to yield the pole in bending is 36,000 in-lb. or 3,000 ft-lb. The mooring tension is 3,000 lb. Therefore the moment arm required for mooring tension to cause pole straightening is $3000 \text{ ft-lb.} / 3000 \text{ lb.} = 1 \text{ ft}$ (deflection in the opposite direction).

After recovery of the dock and mooring system the pole was straightened out on deck using a come-along. Pole concentricity was checked in case it had become deformed or "oblong". The pole was measured to have less than 0.010" out of round at the top and bottom, so a lack of concentricity was not part of this fault.

3.5.2 Battery Connector Leak

Accelerated activity in two sacrificial anodes revealed minor leakage inside a battery bulkhead connector. It is assumed that some minimal amount saltwater (less than a fraction of a drop) entered the connector while it was in shallow water. The connection then sealed completely at depth. It operated properly throughout the deployment. It is unlikely, however, that this connection would have continued operating over a full four-month period of immersion. The battery housings are diode and fuse protected so this housing would not have contributed to dock failure over time, it was designed to shut down instead.

The connector has been cleaned, tested and re-mated.

3.5.3 LBL Transmitter Fault

The Edgetech LBL transmitter located in the Docking Station Controller Chassis (Doccon) did not operate properly after final testing at WHOI. Some of its intended functions were replaced by adding a separate relay transponder to the mooring wire below the dock.

Both remote heads provided with the Edgetech LBL system leaked compensation oil before they were deployed. One was rebuilt and refilled at WHOI just prior the cruise and it operated without failure. The second was taken as an unreliable deep spare and has not yet been rebuilt. Many of the circuit boards had obviously been used, been reworked poorly or were corroded, and some had salt crystals between components.

The Edgetech system as delivered to MIT engineers included substandard commercial hardware and interface efforts with other subsystems of the Doccon were difficult from the beginning.

3.5.4 Carriage Motor Flooding

The carriage motor, which is compensated with non-toxic Carnation mineral oil, was partially flooded when the station reached the surface. It had been working properly throughout the two-week deployment. The motor was disassembled while we were on site. There was evidence that intense cable strumming had caused at least three screws to back out. One of them was critical; the seal screw that holds the whole housing together, end to end. This screw was not Loctited. It is estimated that the strumming occurred during the long recovery process and not during the two week immersion. A carriage motor and a compensation bottle appear in Figure [15].

Figure [15] Carriage Drive Motor, Housing and Compensation Bladder

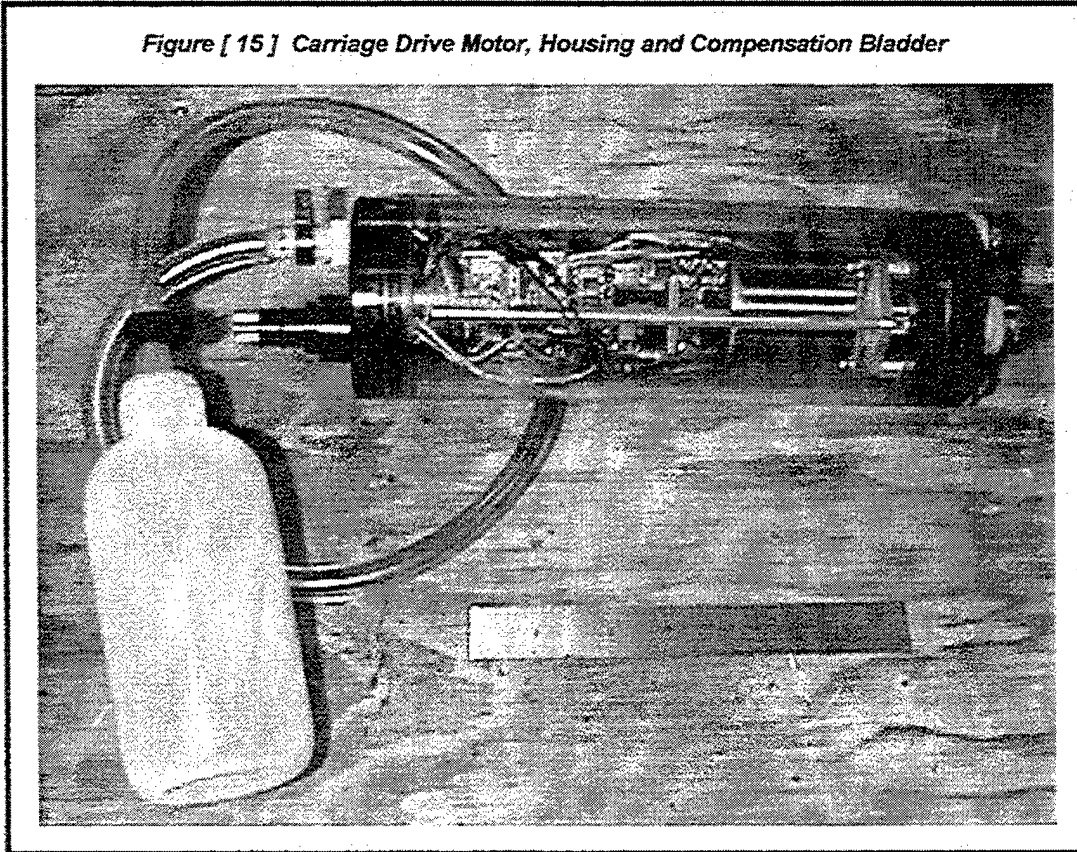

3.6 Proposed Improvements

All of the recommendations made below for the improvement of each subsystem mentioned can be implemented before the next AOSN cruise. The Docking Station System as described in this report has performed well under adverse conditions. The existing design, along with minor changes, will provide a timely and successful demonstration of a fully autonomous AOSN Docking Station for our sponsors at ONR and MIT.

3.6.1 Split Station Modification

I recommend that the docking station housing frame be separated from the juicer by fifty meters of four-conductor EM cable, see Figure [16]. WHOI mooring expert John Kemp agrees with this idea. A two-part Docking Station would be shorter, more easily handled, and less prone to pole bending.

The square base of the existing docking pole has a pattern of eight bolt holes. To these we can attach a triple-purpose clamp, which will: 1) support the Doccon housing across the bottom of the juicer; 2) support the ADV probe, UAM housing, UAM array, and LBL head; and 3) provide a new termination point. The batteries will remain in the existing station frame. This change requires the design of a stainless, triple-purpose clamp and an extra shot of terminated electro-mechanical (EM) cable for power transfer.

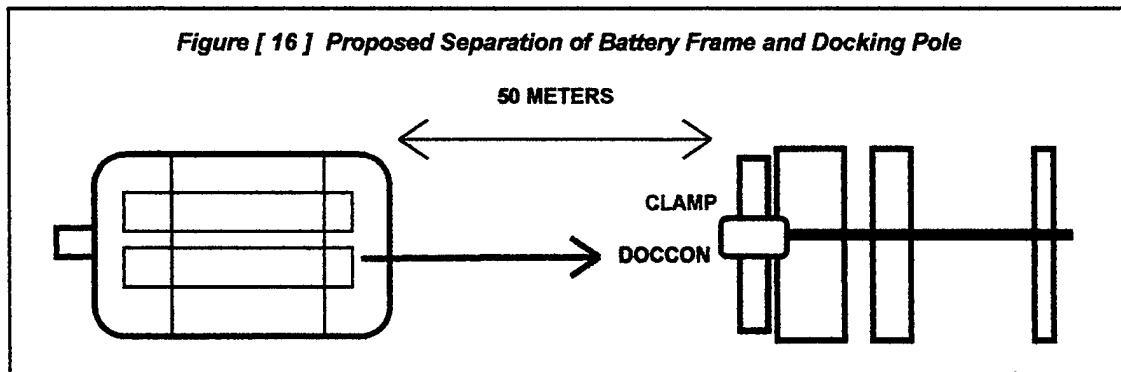

3.6.2 Pinch Capstan Modification

The designer of the pinch capstan assembly, WHOI's Don Peters, has been consulted about the sticking fault. He recommends that the design be changed to a totally roller-guided carriage rather than using a sliding collar and clamp arrangement. There is a tradeoff to consider between looseness of a sliding carriage to accommodate slight pole bending and situations whereby a loose key and keyway cause binding will increase. A newly proposed design implements a triad of guide wheels at both the top and bottom of the moving carriage, all of which have a large-OD-ridge that run in grooves in the pole. This way one could tighten the wheel to groove tolerances and still not hinder carriage movement on a curved pole. (The redesign suggested above is a work in process as of 10 June 1998.)

3.6.3 Edgetech Correction

A solution to the Edgetech LBL receiver fault will be discussed under a separate cover (MIT).

3.6.4 Carriage Motor Compensation

The motor compensation bladder should be pressurized to 2-3 psi above ambient rather than simply kept at ambient. Screws should be Loctited or secured in some manner. Costs and effort for this change are minimal.

3.6.5 Slow Scan Video System Addition

It was difficult to imagine the situation at 500 meters when the vehicle and the station were joined. It is recommended that a snapshot, slow scan video processor and CPU be added to the Doccon and tap into the 485 link to the surface. Also add a hi-resolution camera and 100 w/sec flash to the station carriage, looking downward. An interrupt from the surface or a timer fires off one shot which is reassembled at the surface as soon as the link can manage; however hi-speeds are not crucial. In this way operators will be able to look in on the dock situation without a demand for increased bandwidth from the as-built system.

The idea of a snapshot video system setup to look down the docking pole would satisfy a question raised in early 1997 regarding how the Station would be able to detect the presence of a docked vehicle if the carriage was not closed and the appropriate magnetic switches were not activated.

Figure [17] Odyssey Labrador Sea Mooring Detail, AEL Revision 4

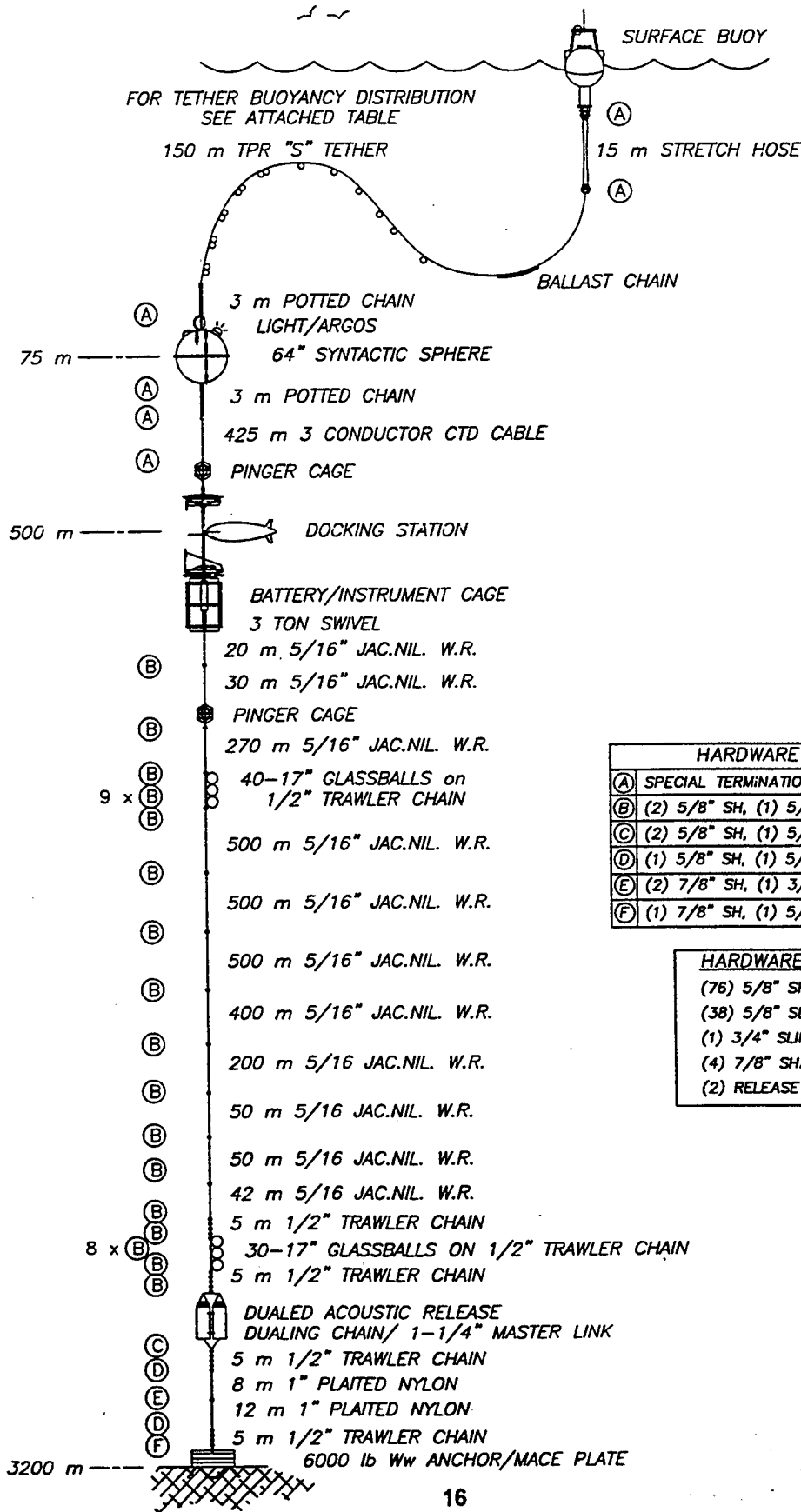

HARDWARE DESIGNATION	
(A)	SPECIAL TERMINATION
(B)	(2) 5/8" SH, (1) 5/8" SL
(C)	(2) 5/8" SH, (1) 5/8" SL, (1) RELEASE LINK
(D)	(1) 5/8" SH, (1) 5/8" SL, (1) 7/8" SH
(E)	(2) 7/8" SH, (1) 3/4" SL
(F)	(1) 7/8" SH, (1) 5/8" SL, (1) 5/8" SH

HARDWARE REQUIRED	
(76)	5/8" SHACKLES
(38)	5/8" SLING LINKS
(1)	3/4" SLING LINK
(4)	7/8" SHACKLES
(2)	RELEASE LINKS



29 MAY 98

F

E

D

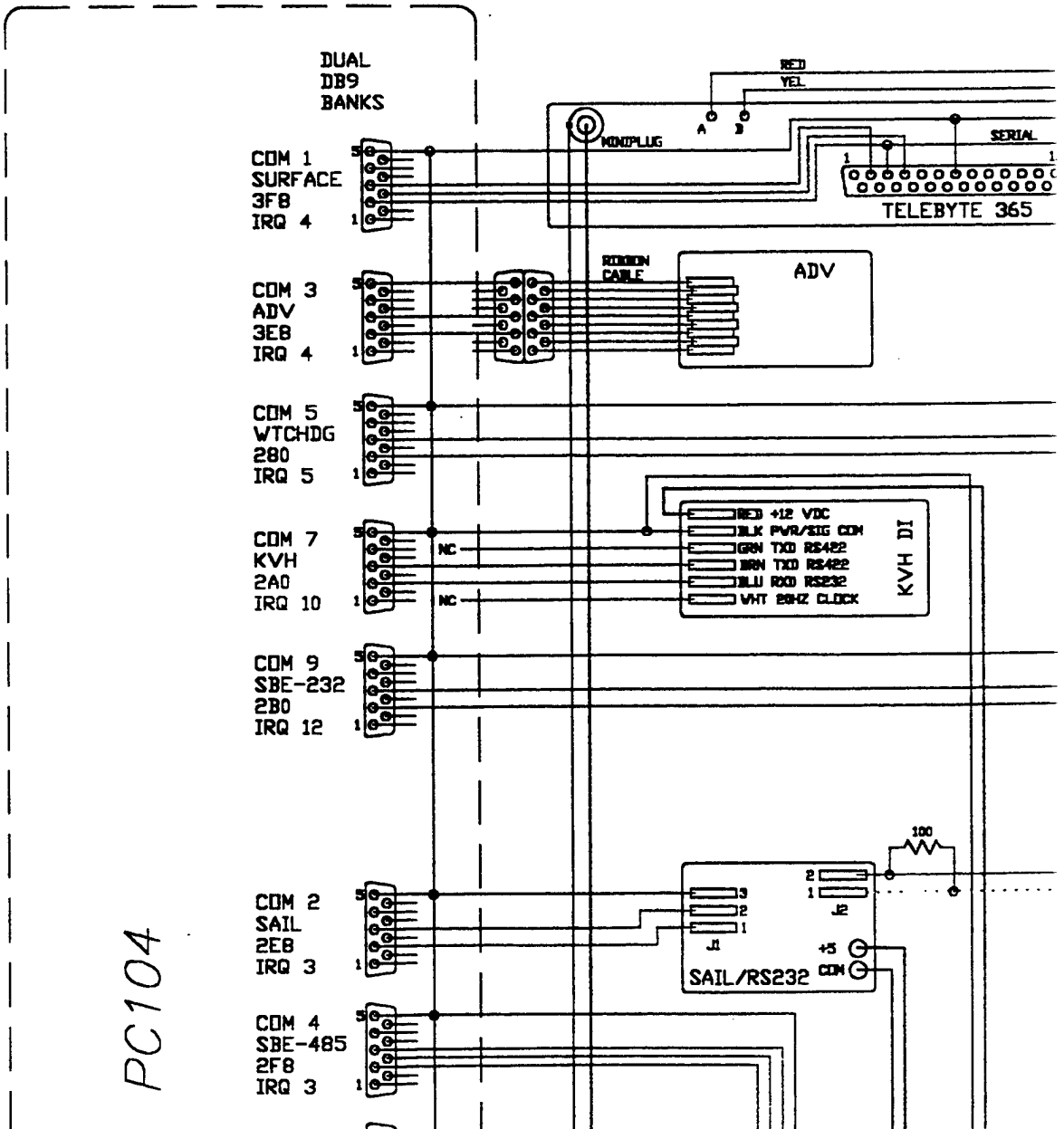

PC104

ENDCAP BULKHEAD

98

SBE-232
IE VSG4BCL

EDGETECH RH
IE VSG3PBCLM

EDC ETHERNET
IE MBH9FS

SURF
SBE-
SC V

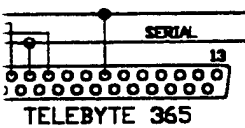

VDD
MLU

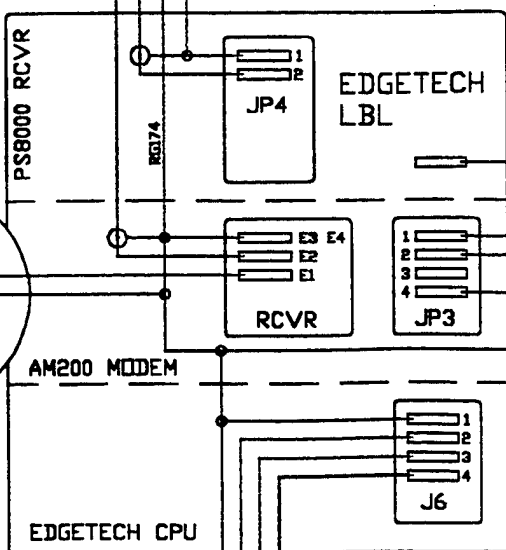
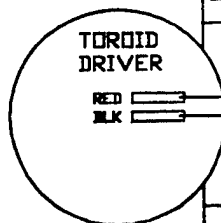
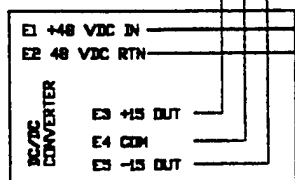

AM200 MODEM

EDGETECH CPU

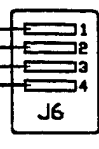
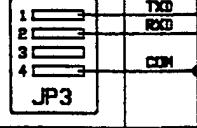

SAIL -
SAIL +

3

5

IDCAP BULKHEADS FACE VIEW

ETHERNET
3H9FS

SURFACE-485
SBE-485
SC VSG4BCL

DTMF RES
BEACON P
IE BH4MP

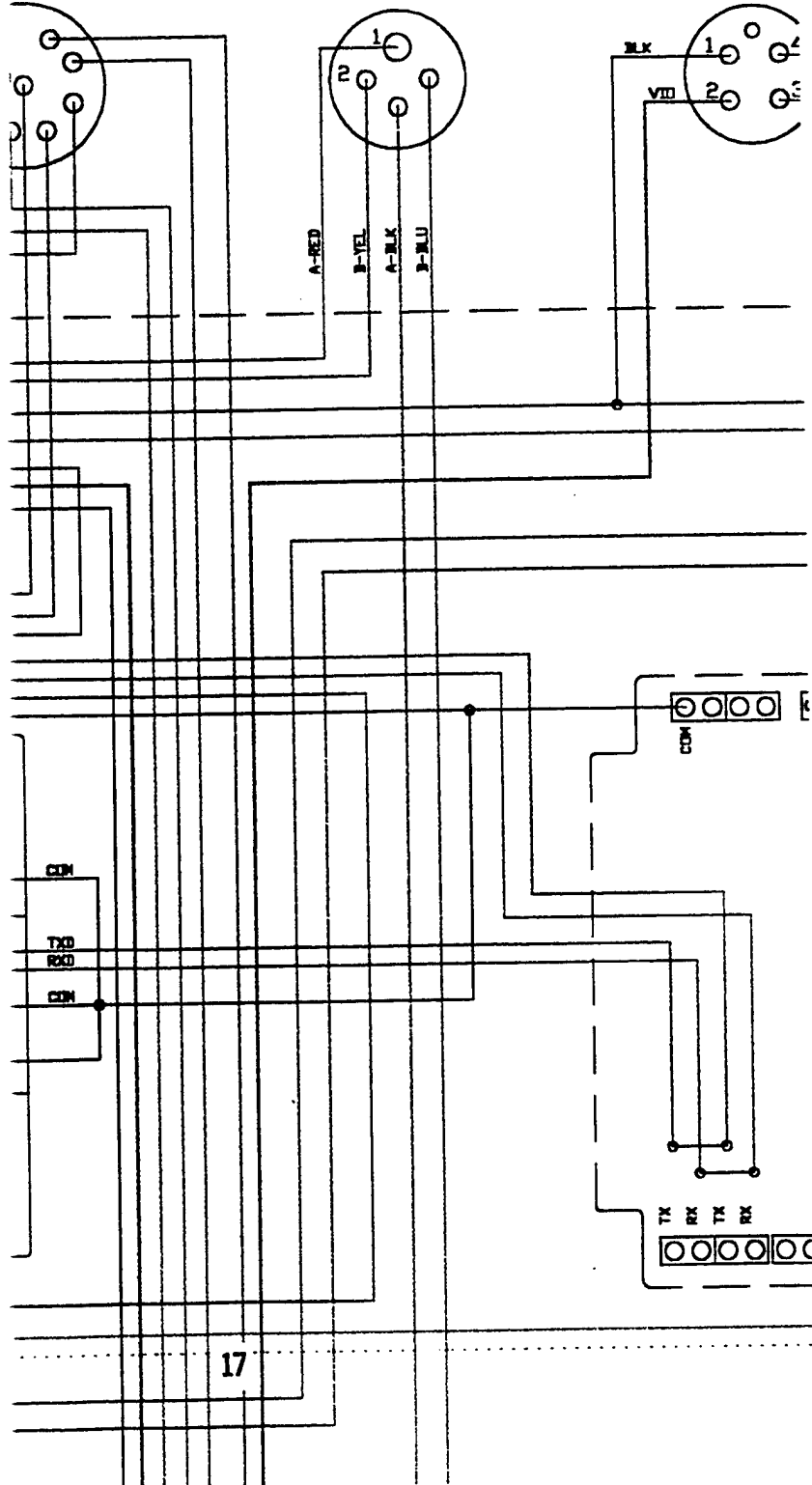

17

W

ET
WR OUT

EDC AC POWER
IE BH4FS

ADV PROBE
IE MBH9FS

UAM MODEM DTE
SC XSJ7BCR

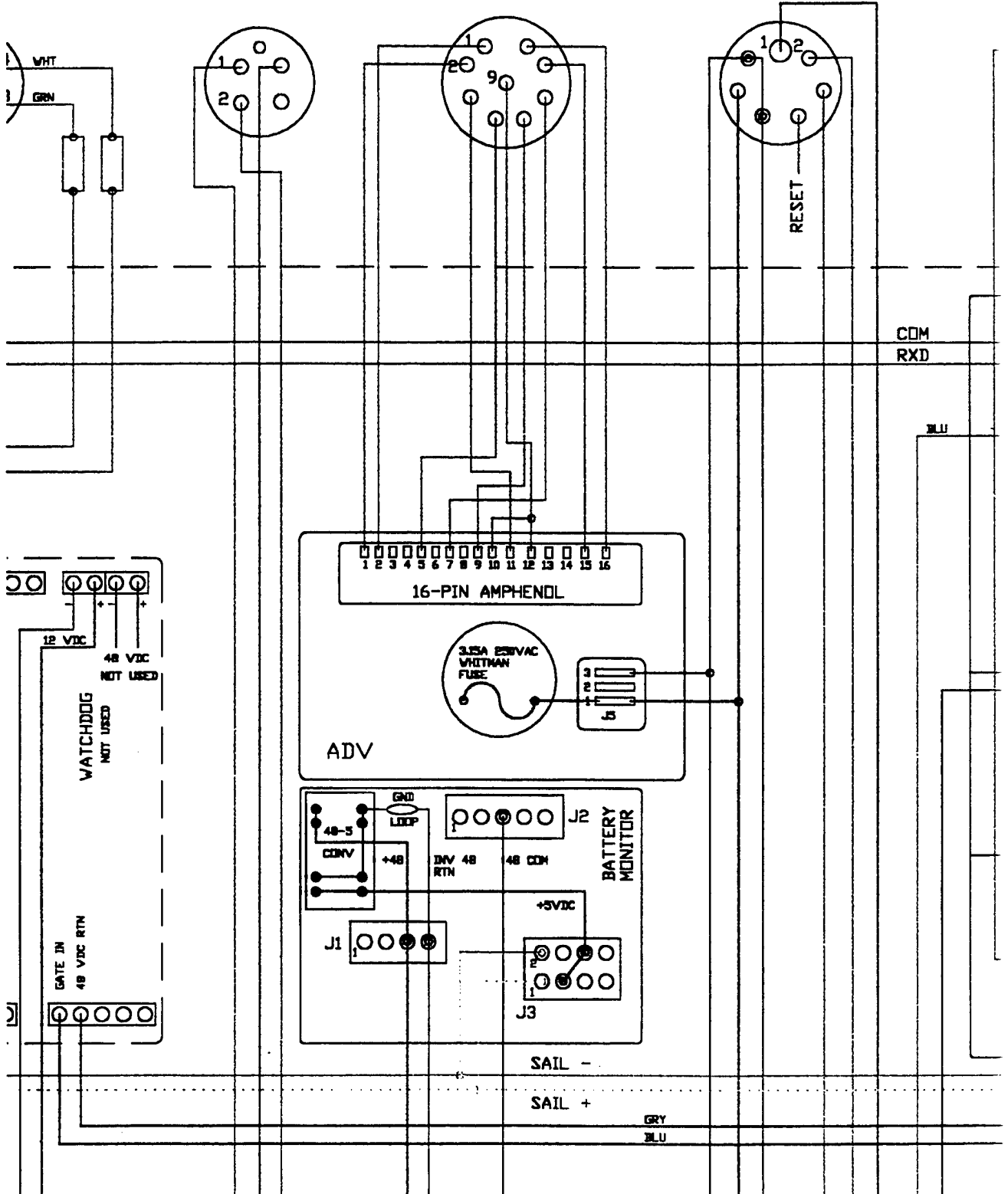

COM
RXD

BLU

16-PIN AMPHENDL

ADV

3.15A 250VAC
WHITMAN
FUSE

3
2
1
5

BATTERY
MONITOR

J1

J2

J3

SAIL -

SAIL +

GRY
BLU

PAROSCI DEPTH
JUICER MOTOR
MAGNETIC SWITCHES
IE XSL20BCR

23-DAY
BATTERY BANK 1
SC XSG2BCL

DEM DTE
7BCR

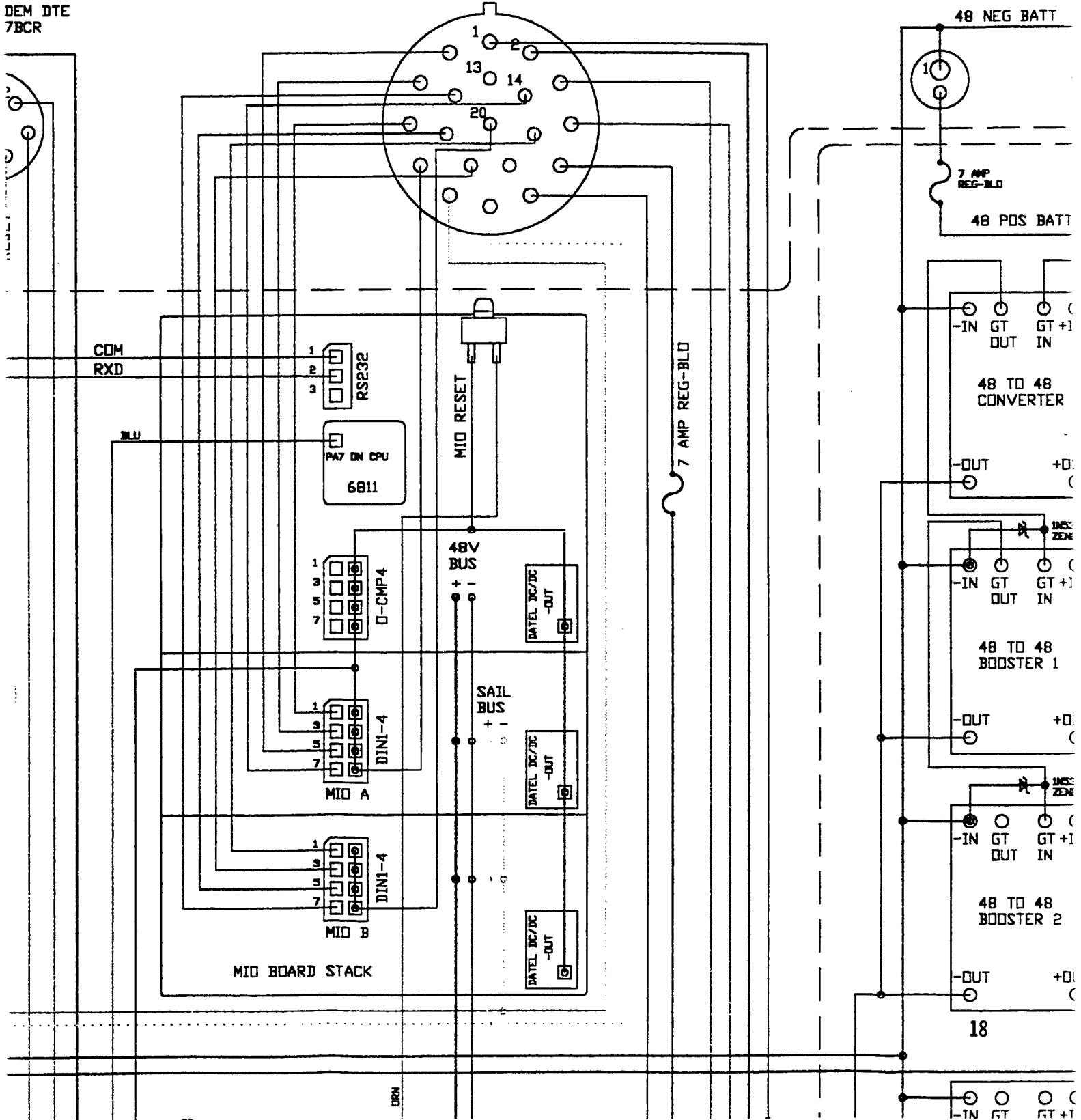

23-DAY
BATTERY BANK 1
SC XSG2BCL

23-DAY
BATTERY BANK 2
SC XSG2BCL

48 NEG BATT



7 AMP
REG-BLD

7 AMP
REG-BLD

48 POS BATT

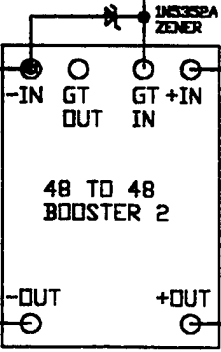
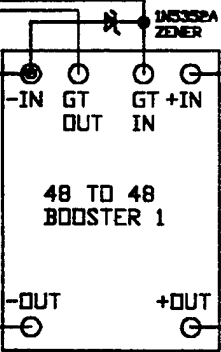
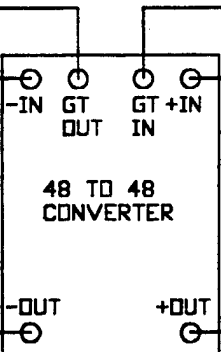

18



INVERTERS

F

F

D

3

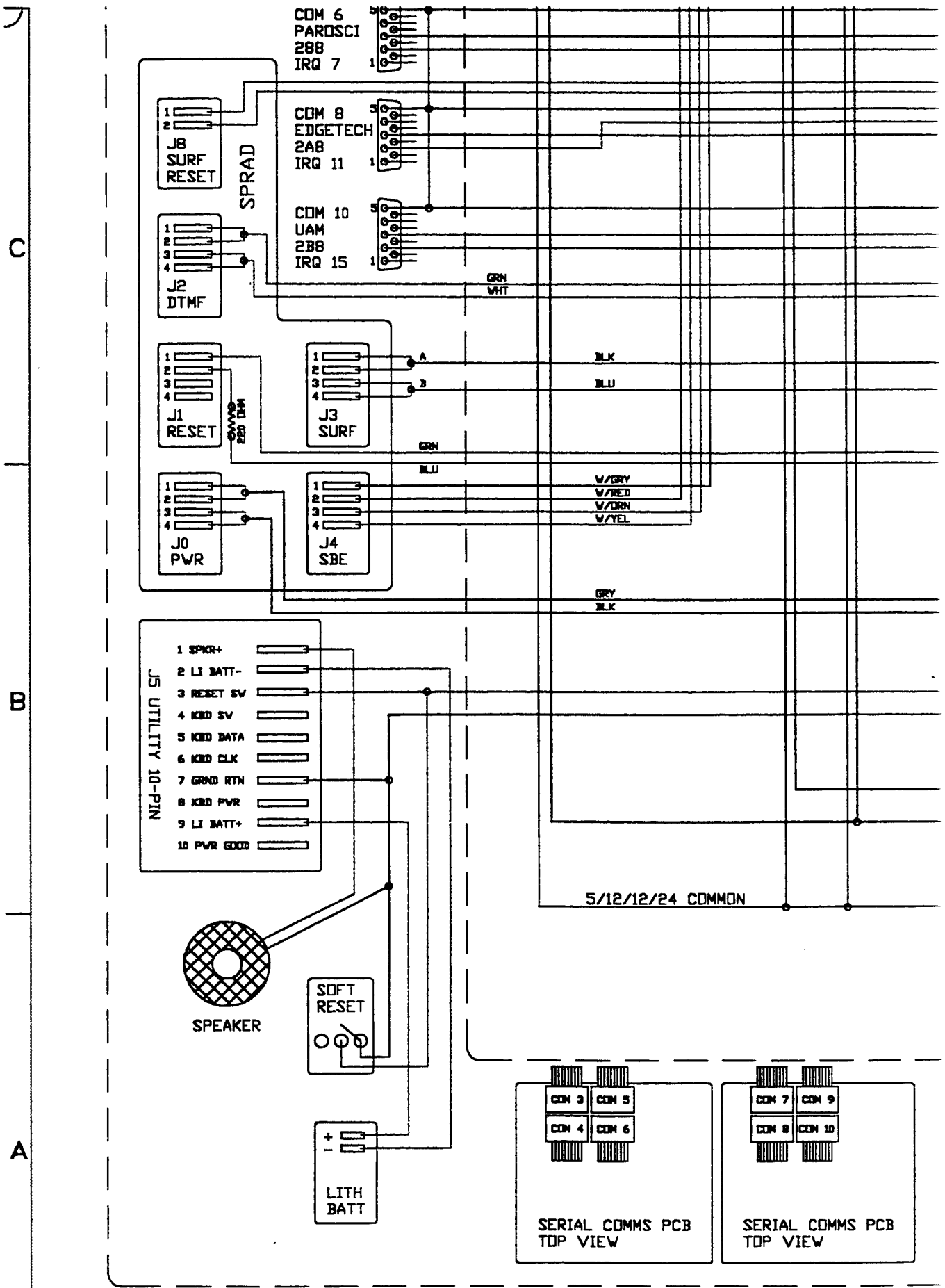

2

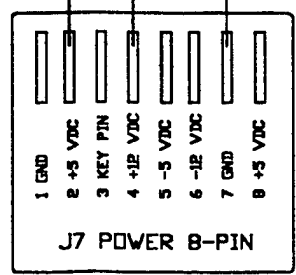
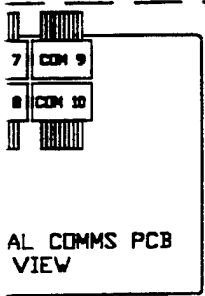
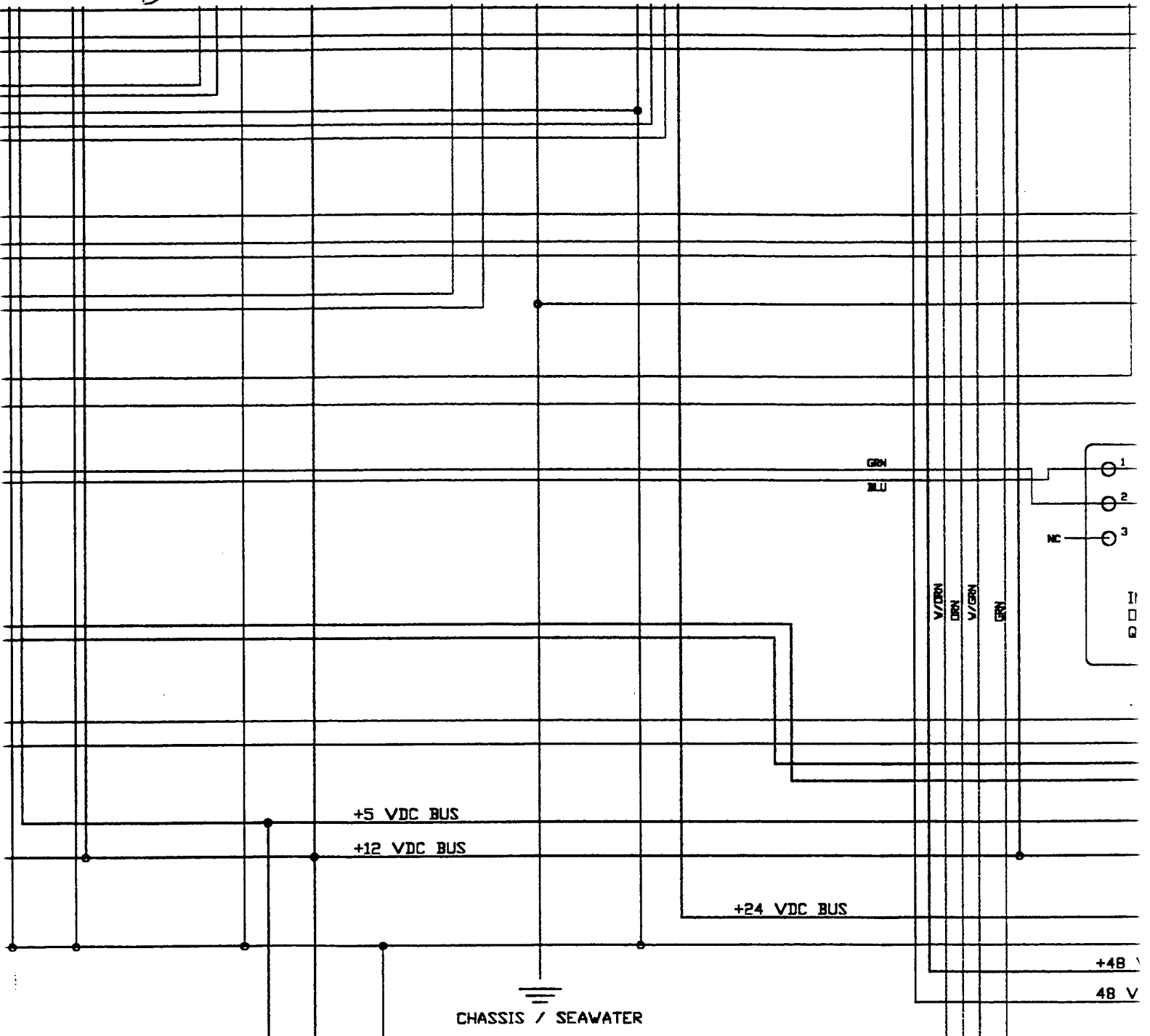

PC104

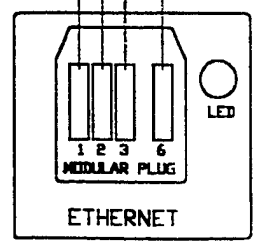

19

3

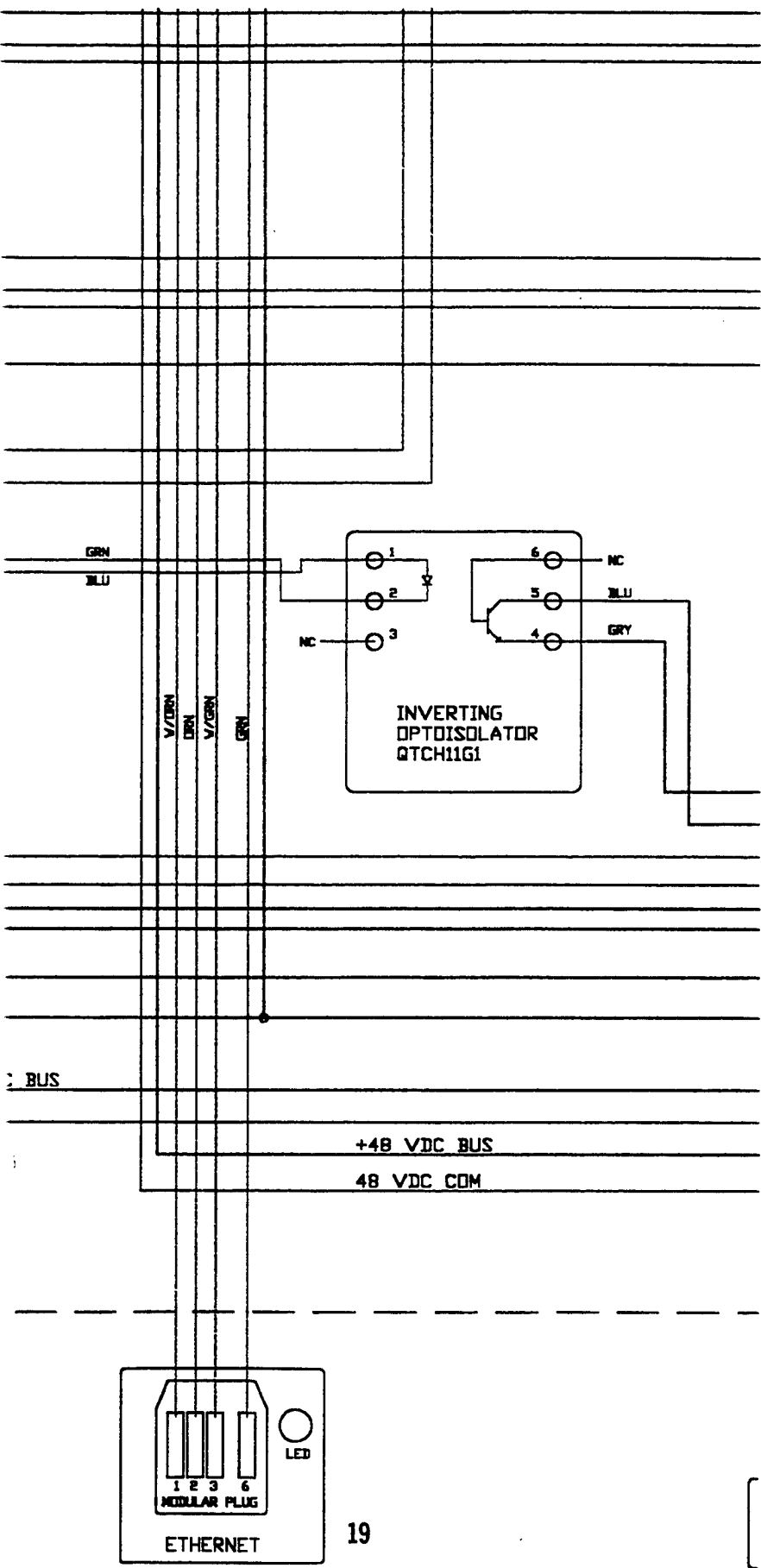

: BUS

+48 VDC BUS
48 VDC COM

ETHERNET

19

5

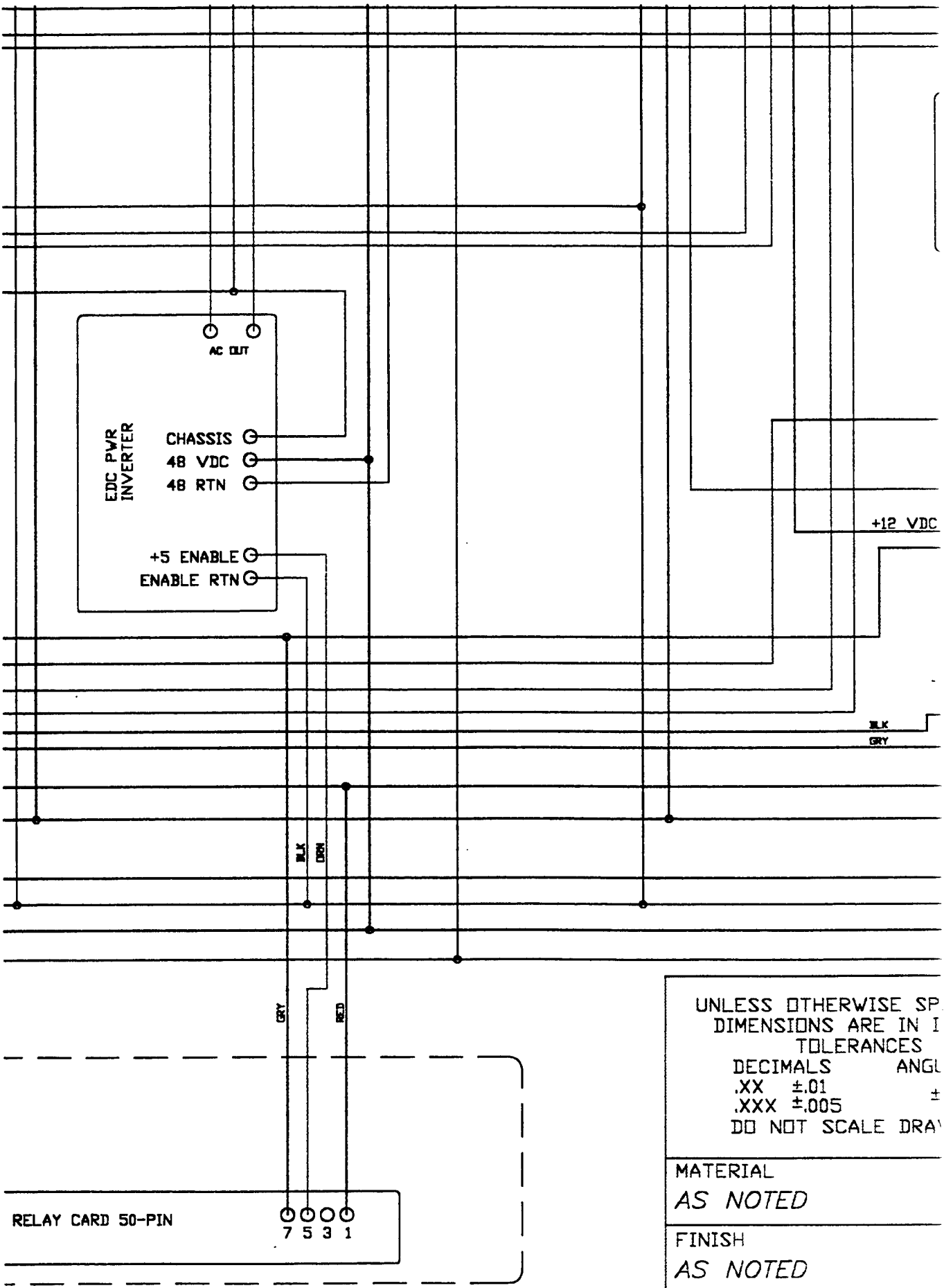

UNLESS OTHERWISE SP
 DIMENSIONS ARE IN I
 TOLERANCES
 DECIMALS ANGL
 .XX ±.01 ±
 .XXX ±.005 ±
 DO NOT SCALE DRAW

MATERIAL
 AS NOTED

FINISH
 AS NOTED

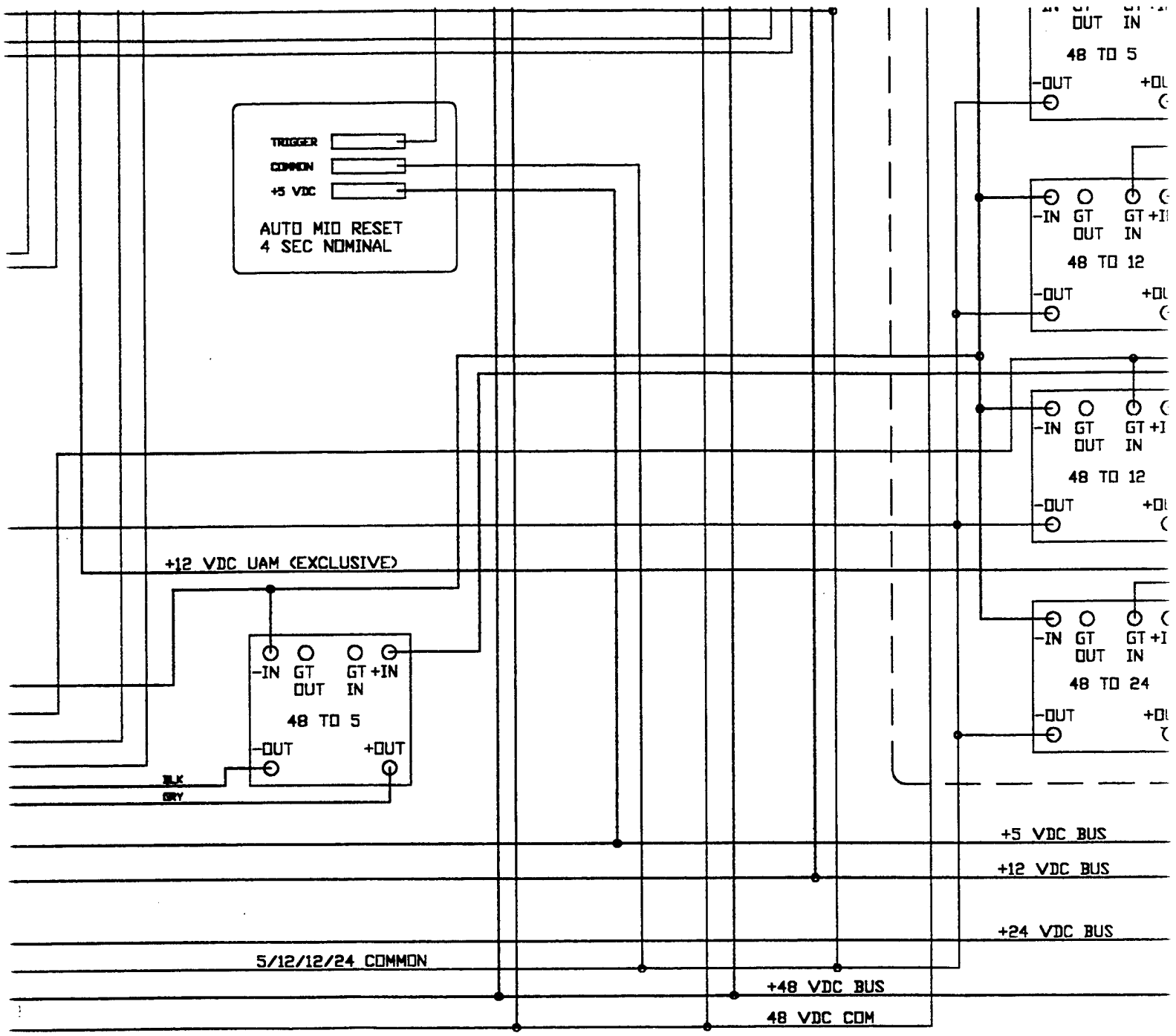

LESS OTHERWISE SPECIFIED DIMENSIONS ARE IN INCHES
 TOLERANCES
 DECIMALS ANGULAR
 .XX ±.01 ±1'
 .XXX ±.005
 DO NOT SCALE DRAWING

REVISIONS
 NOTED

DATE
 NOTED

PROJECT NO. 000000.00	
DRAWN MF BOWEN	DATE 29 May 98
CHECK	
AOP&E	MS #9
BIG 402	289-3420

WOODS HOLE OCEANOGRAPHIC INSTITUTE APPLIED OCEAN PHYSICS & GEOPHYSICS WOODS HOLE, MASSACHUSETTS	
TITLE WIRING DIAGRAM DOCK CONTROL	
SIZE D	DWG NO. 20 15
SCALE NONE	RELEASE DATE

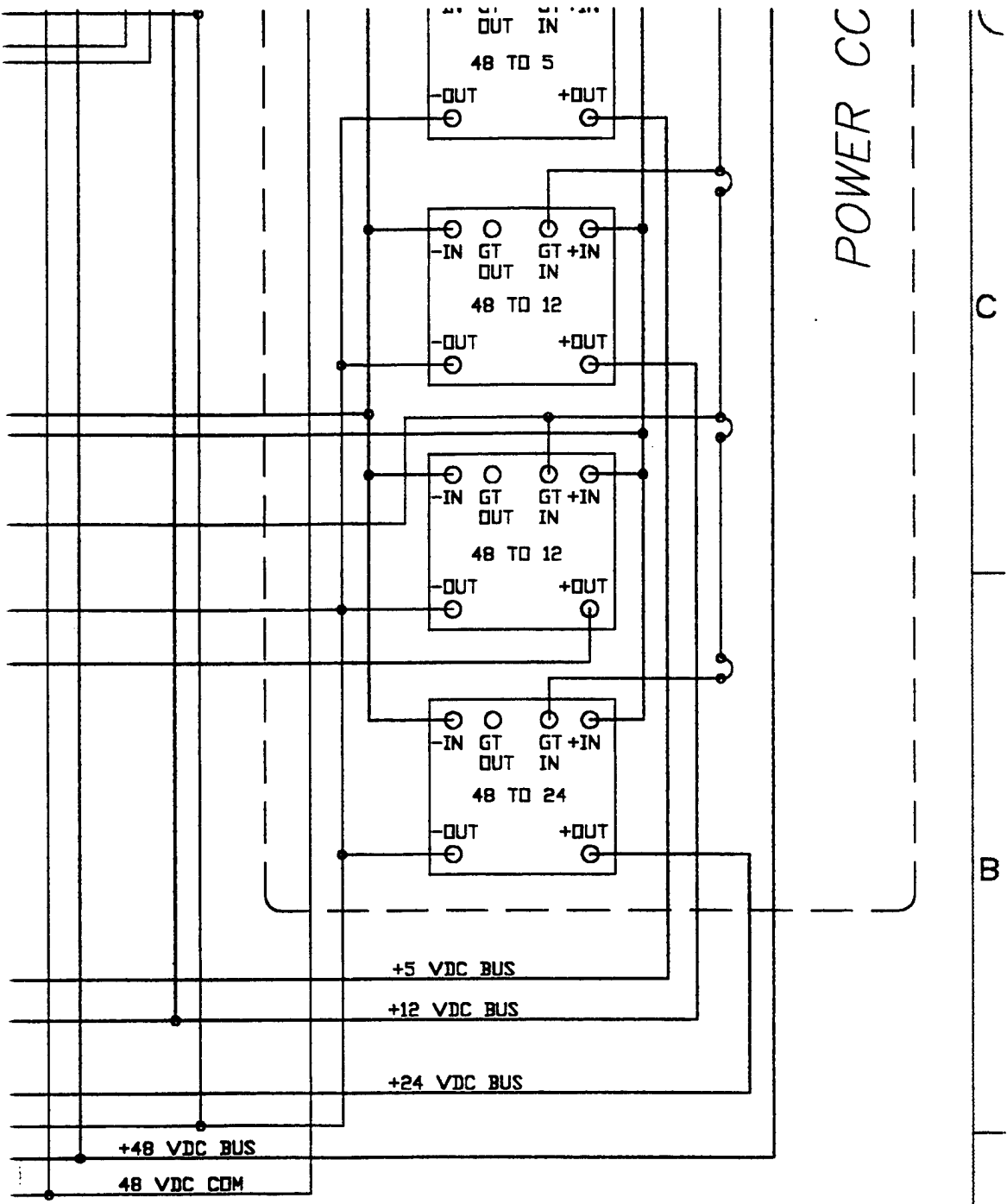

WOODS HOLE OCEANOGRAPHIC INSTITUTION
 APPLIED OCEAN PHYSICS & ENGINEERING
 WOODS HOLE, MASSACHUSETTS, 02543



98 TITLE

WIRING DIAGRAM
 DOCK CONTROLLER, REV K

SIZE

D

DWG NO.

20

156-97-100

SCALE

NONE

RELEASE DATE

SHEET

OF

AOSN Lab Sea Vehicle Dock
Drawing Numbers

0490ASSY		Vehicle Dock and Battery Frame Assembly
04900000		Vehicle Dock Assembly
	0491	Pole Structure
*	04910100	Pole Weldment
*	04910101	Pole Anode
	04910200	Pole Top Bumper
	0492	Hoop/Skirts
*	04920100	Upper Hoop
*	04920101	Hoop Center Plate
	04920200	Lower Hoop
*	04920300	Hoop Clamp, Lower
*	obs 04920301	Hoop Clamp, Carriage
	04930000	Dock Carriage
*	04930101	Mount Plate
*	04930102	Bearing Block 1
*	04930103	Bearing Block 2
*	04930104	Motor Mount Block
*	04930105	Spring Post
	04930200	Friction Drive Wheel
*	04930201	Idler Wheel
	04930301	Drive Shaft
*	04930302	Idler Shaft
	obs 04930400	Slider Assembly
*	obs 04930401	Slider Sleeve
*	obs 04930402	Slider Flange
*	obs 04930403	Slider Key
	04930500	Slider Assembly
*	04930501	Slider Upper Attachment
*	04930502	Slider Lower Attachment
*	04930503	Slider Shaft
*	04930504	Slider Key
	04940000	Battery Frame Assembly
*	04940100	Frame Weldment
	04940200	Spine
*	04940201	Upper Crosspiece
*	04940202	Lower Crosspiece
	04940301	Pickup Bale
*	04940302	Bottom Tang
	04940401	Battery Case Strap
*	04940501	Instrument Housing Bracket

	0495		Battery Case
*		04950100	Tube
*		04950101	Bulkhead
*		04950200	Endcap
*		04950201	Endcap Penetrations
*		04950202	Endcap Penetration Detail
*	obs	04950300	Mounting Tab Location
*		04950301	Mounting Tab
→			

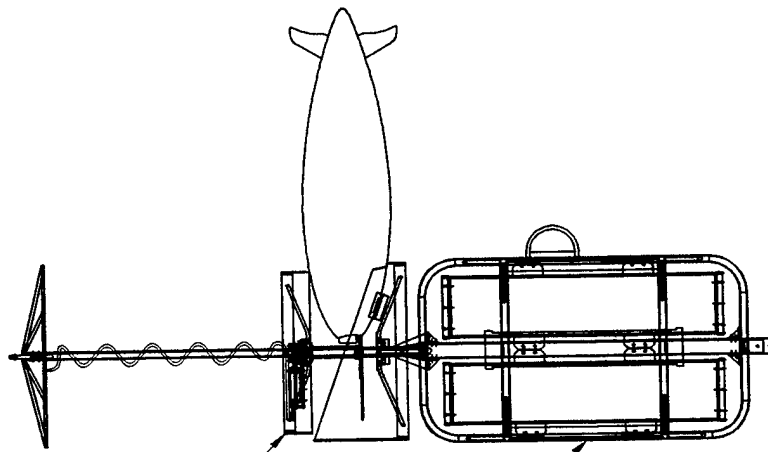
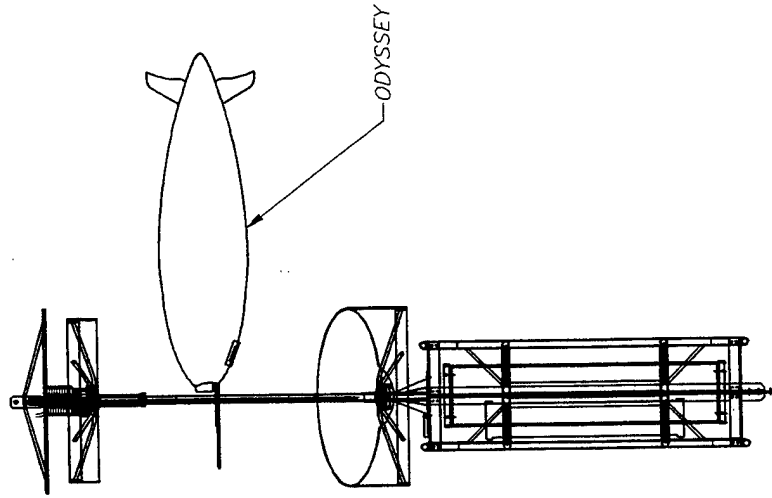
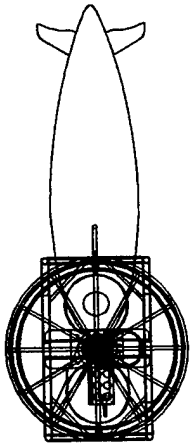

DWG #049-0-0000

DWG #049-4-0000

UNLESS OTHERWISE SPECIFIED DIMENSIONS ARE IN INCHES DECIMALS ARE IN THOUSANDS ALL DIMENSIONS ARE TO CENTER UNLESS NOTED OTHERWISE ALL DIMENSIONS ARE TO CENTER UNLESS NOTED OTHERWISE DO NOT SCALE DRAWING		DRAWN DON PETERS	DATE 07/07/97	SHEET NO. 049-0-ASSY
PAROLET NO. 000000.00		CHECK []	TITLE AOSN VEHICLE DOCK AND BATTERY FRAME ASSEMBLY	SCALE []
MATERIAL AS NOTED		FINISH AS NOTED		RELEASE DATE []

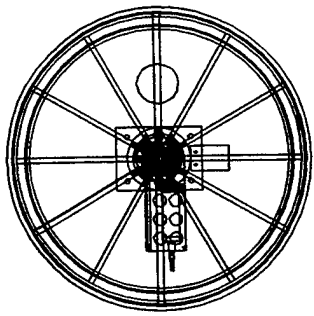

DWG #049--1-0200

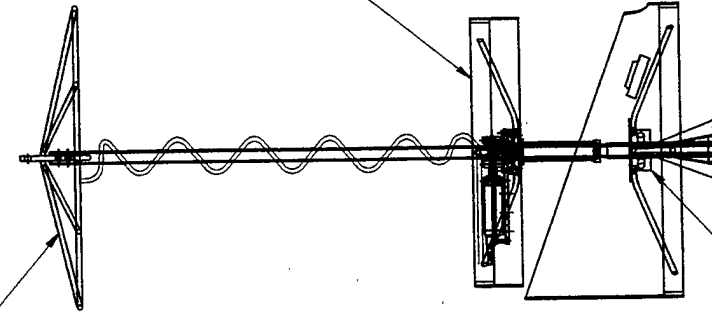

DWG #049-1-0300

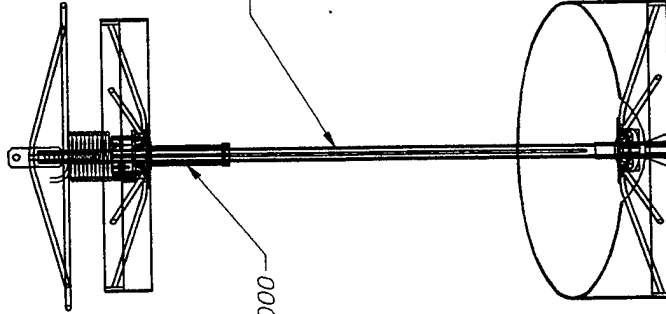

DWG #049-1-0100

DWG #049-3-0000

DWG #049-2-0100

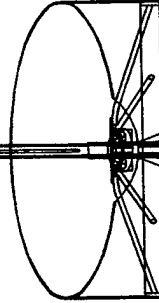

DWG #049-2-0200

DWG #049-1-0101

UNLESS OTHERWISE SPECIFIED DIMENSIONS ARE IN INCHES FRACTIONS ARE IN 16ths DECIMALS ARE IN 10ths DIMENSIONS ARE TO CENTER UNLESS NOTED DO NOT SCALE DRAWING		PROJECT NO. 000000.00	DATE 07/07/87	VOISIS WALK OCEANOGRAPHIC INSTITUTION APPLIED OCEAN PHYSICS & ENGINEERING VOISIS HALL, WASHINGTON DC 20543	
DRAWN DON PETERS		CHECK	TITLE AOSN VEHICLE DOCK ASSEMBLY		
MATERIAL AS NOTED		FINISH AS NOTED	SCALE	DWG NO. 049-0-0000	SHEET OF
				RELEASE DATE	

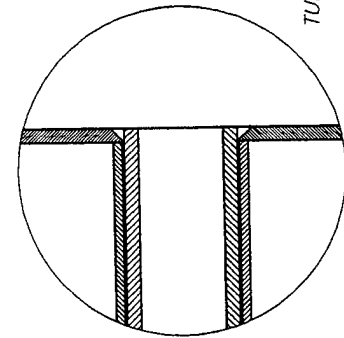
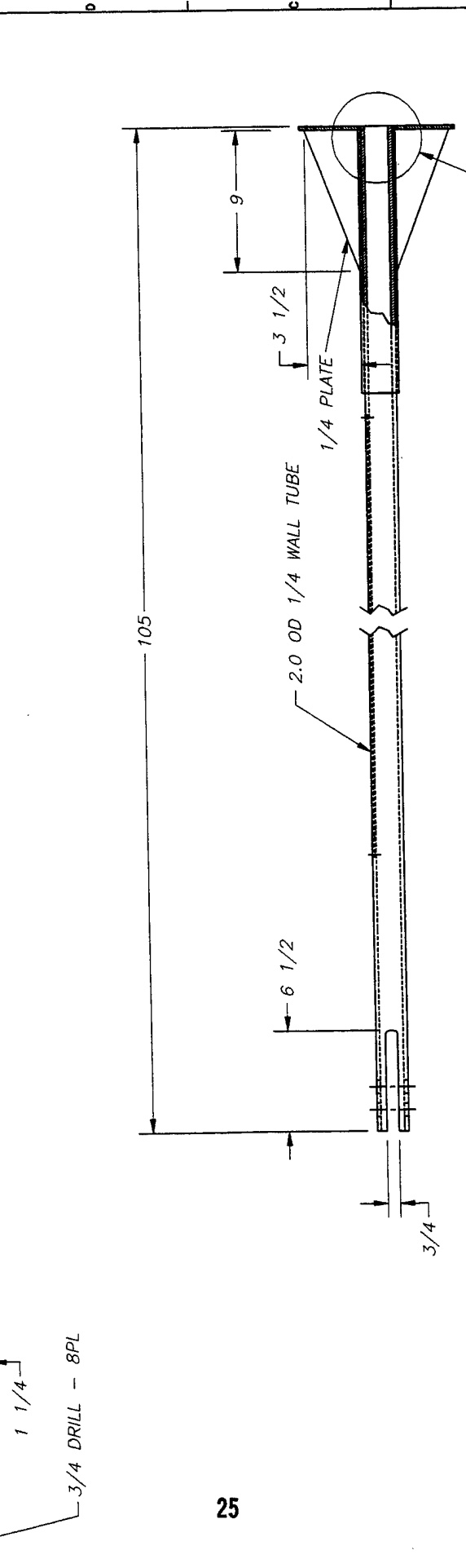
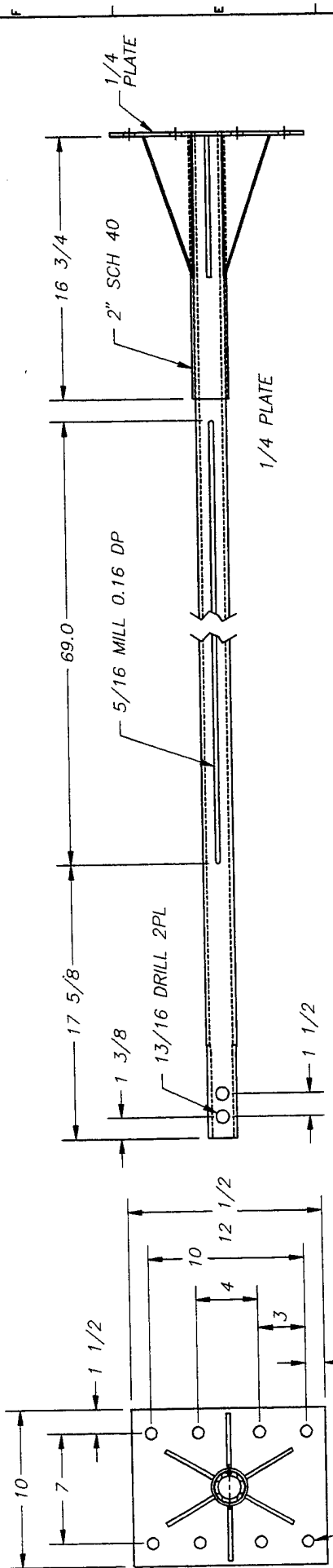

TUBE BASE DETAIL

PROJECT NO. 156768.08		DATE 09/22/97	
DRAWN DON PETERS		CHECK DON PETERS	
UNLESS OTHERWISE SPECIFIED DIMENSIONS ARE IN INCHES TOLERANCES DECIMALS ±.005 ANGULAR ±1° XX ±.005 XXX ±.005 DO NOT SCALE DRAWING			
MATERIAL STAINLESS			
FINISH AS NOTED			
TITLE AOSN VEHICLE DOCK DOCKING POLE		SIZE DWG NO. 049-1-0100	SCALE RELEASE DATE SHEET OF

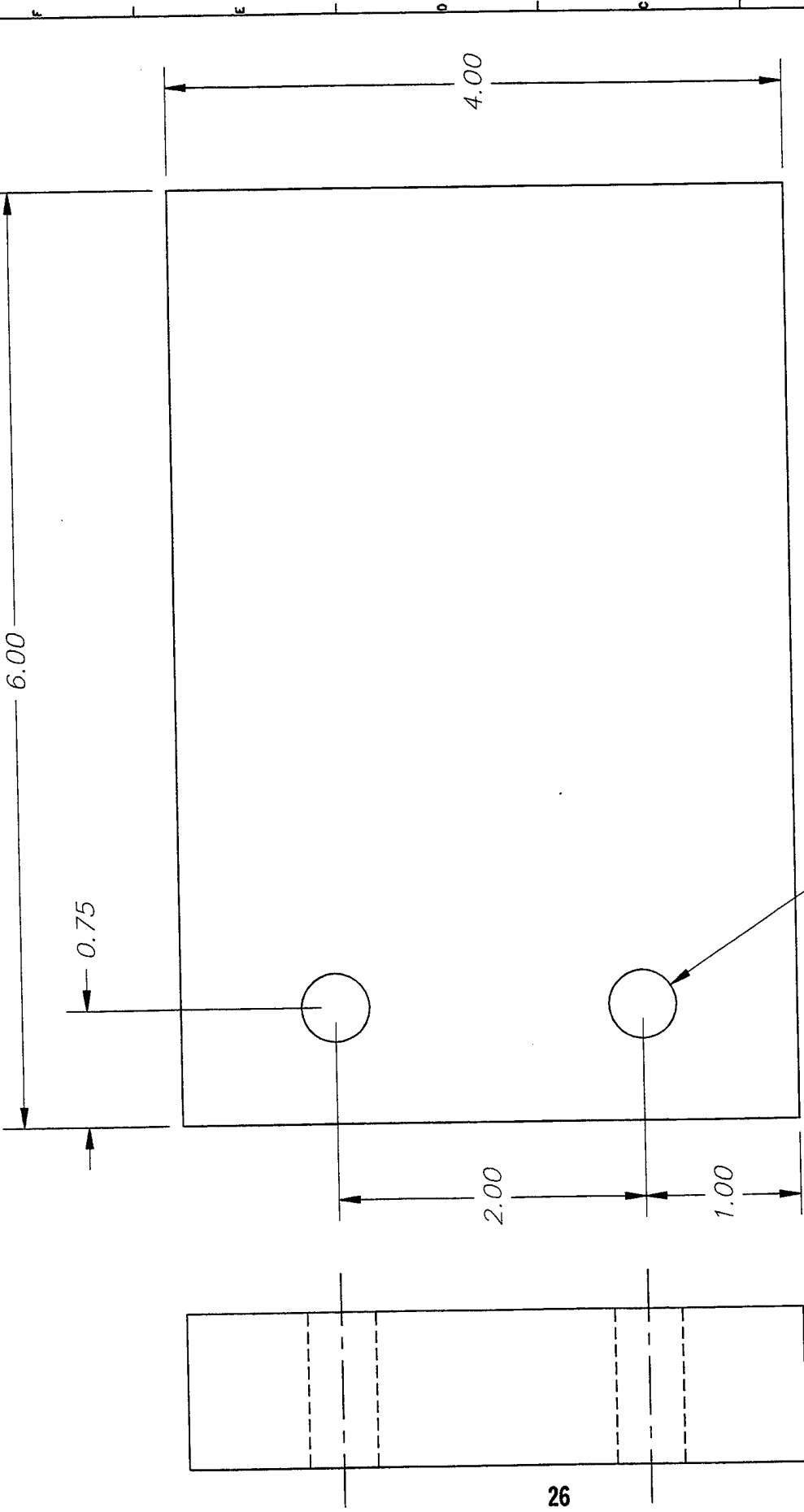

7/16 DRILL - 2PL

UNLESS OTHERWISE SPECIFIED DIMENSIONS ARE IN INCHES TOLERANCES DECIMALS ±.01 ANGULAR ±1° XXX 50MS DO NOT SCALE DRAWING		PROJECT NO. 750394.01	DATE 12/31/97	VERRIS HOLE OCEANOGRAPHIC INSTITUTION APPLIED OCEAN PHYSICS & ENGINEERING VERRIS HOLE, MASSACHUSETTS, 02543
MATERIAL 1X4 FLAT BAR MILD STEEL		DRAWN DON PETERS	TITLE AOSN VEHICLE DOCK POLE ANODE	DWG NO. 049-1-0101
FINISH AS NOTED		CHECK	SCALE	RELEASE DATE
		SHEET	OF	SHEET

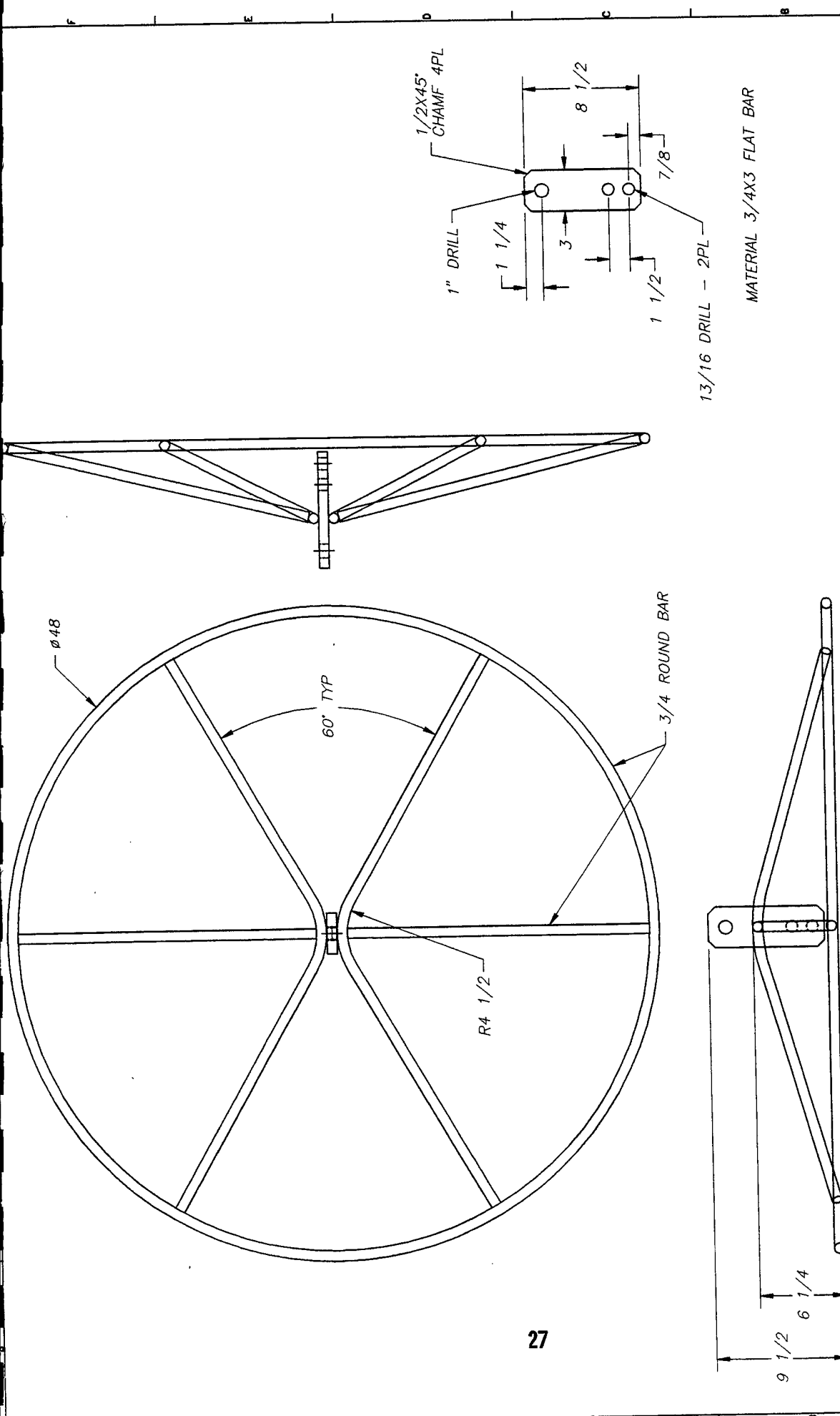

REVISED 09/29/97: HOLE DIAMETERS

WORLD'S HOLE OCEANOGRAPHIC INSTITUTION
 APPLIED OCEAN PHYSICS & ENGINEERING
 WOODS HOLE, MASSACHUSETTS, 02543

TITLE
**AOSN VEHICLE DOCK
 POLE TOP BUMPER**

SIZE
 DWG NO. 049-1-0200

SCALE
 RELEASE DATE
 SHEET OF

UNLESS OTHERWISE SPECIFIED DIMENSIONS ARE IN INCHES TOLERANCES DECIMALS .XX ±0.01 ANGULAR ±1' XXV ±0.005 DO NOT SCALE DRAWING	PROJECT NO. 156077.00	DATE 09/22/97
	DRAWN DON PETERS	CHECK
MATERIAL STAINLESS		
FINISH AS NOTED		

DWG 049-2-0101

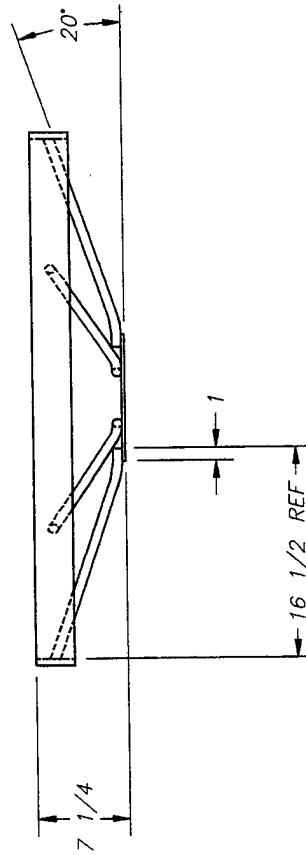
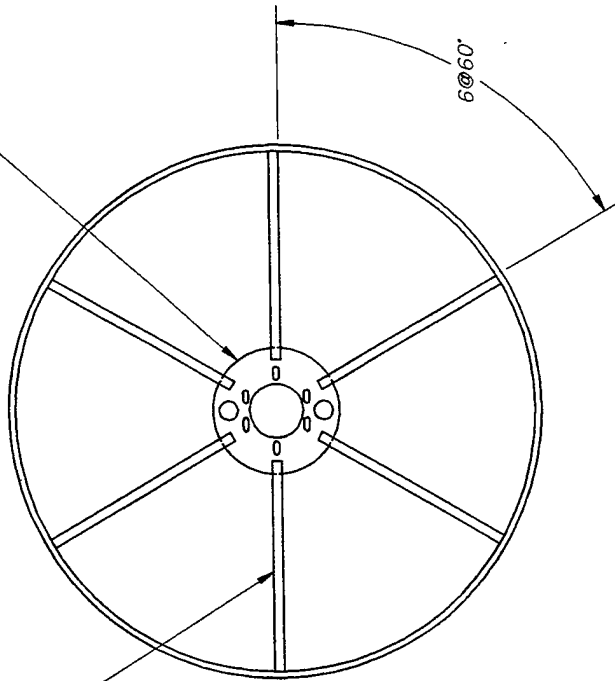
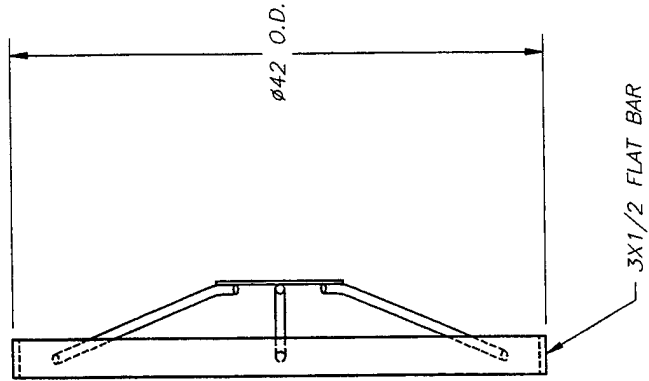

UNLESS OTHERWISE SPECIFIED DIMENSIONS ARE IN INCHES DECIMALS .XX ±.01 .XXX ±.005 DO NOT SCALE DRAWING		PROJECT NO. 156168.08	DATE 07/07/97	TITLE AOSN VEHICLE DOCK UPPER SKIRT HOOP	VOODS HOLE OCEANOGRAPHIC INSTITUTION APPLIED OCEAN PHYSICS & ENGINEERING VOODS HOLE, MASSACHUSETTS, 02543
MATERIAL 6061-T6 ALUMINUM	FINISH AS NOTED	DRAWN DON PETERS	CHECK	SIZE DWG NO. 049-2-0100	SCALE
				RELEASE DATE	SHEET OF

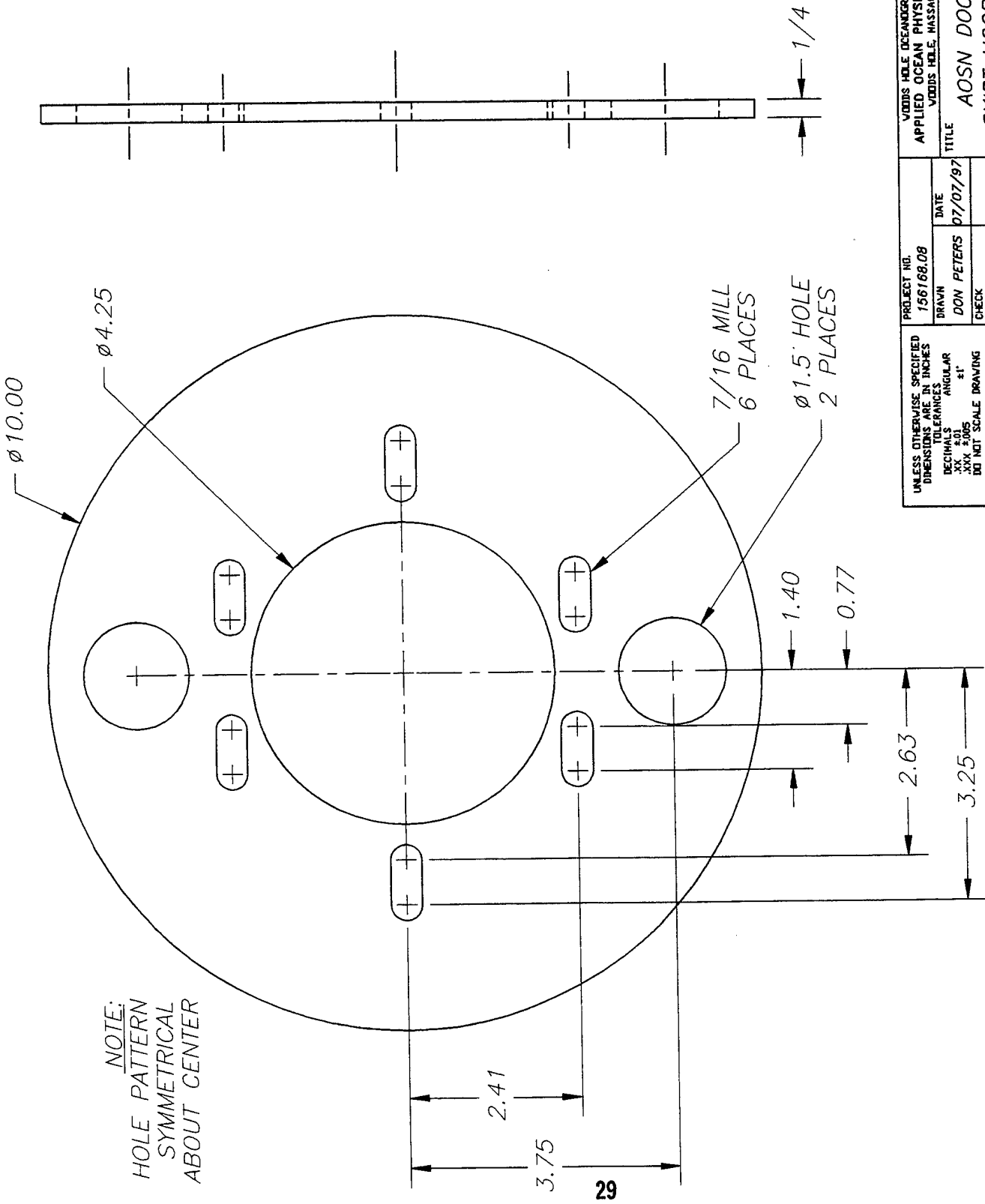

NOTE:
HOLE PATTERN
SYMMETRICAL
ABOUT CENTER

UNLESS OTHERWISE SPECIFIED DIMENSIONS ARE IN INCHES TOLERANCES DECIMALS ±.015 XX ±.005 XXX ±.002 DO NOT SCALE DRAWING		PROJECT NO. 156168.08	DATE 07/07/97	VIDDIS HOLE OCEANOGRAPHIC INSTITUTION APPLIED OCEAN PHYSICS & ENGINEERING VIDDIS HOLE, MASSACHUSETTS 02543
MATERIAL 6061-T6 1/4 PLATE	DRAWN DON PETERS	CHECK []	TITLE AOSN DOCKING STATION SKIRT HOOP CENTER PLATE	SIZE []
FINISH AS NOTED	[]	[]	SCALE []	Dwg No. 049-2-0101
[]	[]	[]	RELEASE DATE []	SHEET 0F

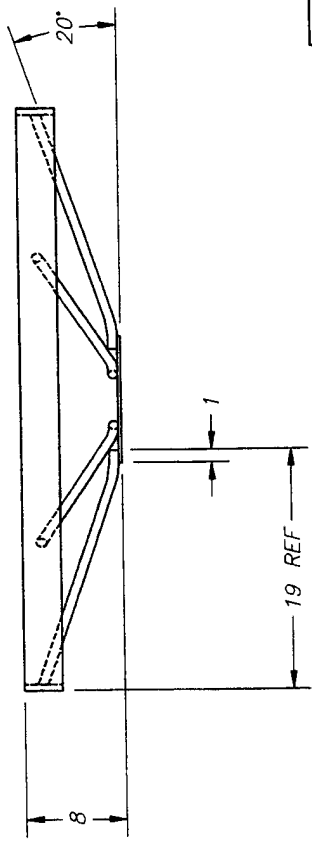
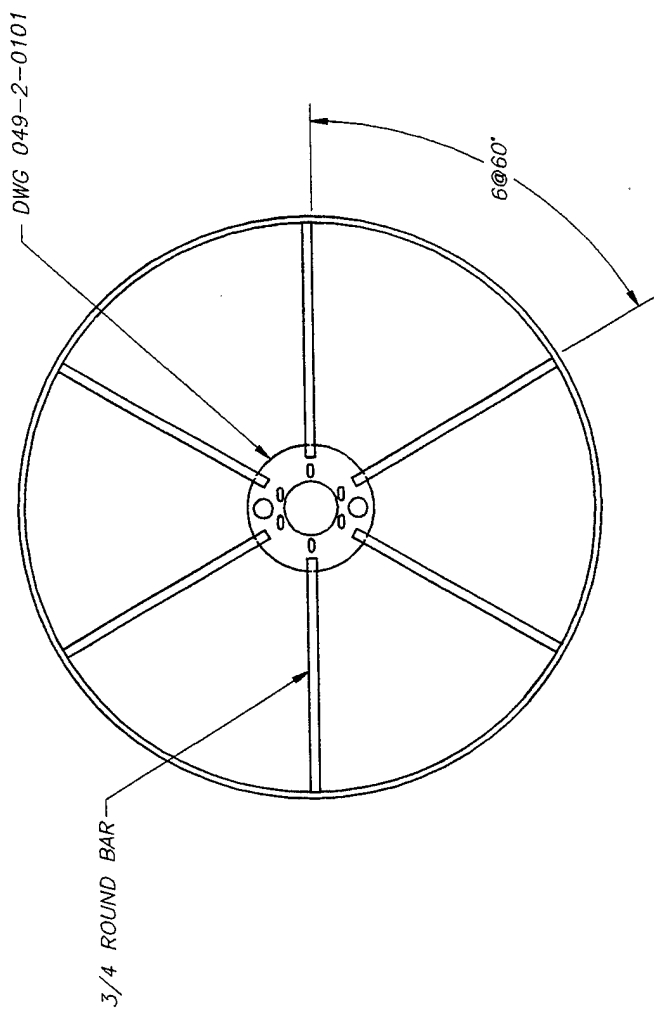
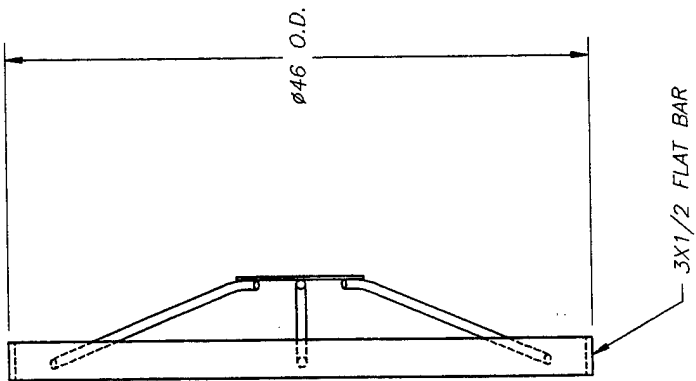

UNLESS OTHERWISE SPECIFIED DIMENSIONS ARE IN INCHES TOLERANCES DECIMALS .XX ±.01 XXX ±.005 DO NOT SCALE DRAWING		PROJECT NO. 756768.08		VIGOR'S HOLE OCEANOGRAPHIC INSTITUTION APPLIED OCEAN PHYSICS & ENGINEERING VIGOR'S HOLE, MASSACHUSETTS, 02543	
MATERIAL 6061-T6 ALUMINUM	DATE 07/07/97	DRWN DON PETERS	TITLE AOSN VEHICLE DOCK LOWER SKIRT HOOP		
FINISH AS NOTED	CHECK	SCALE	SIZE DWG NEL	RELEASE DATE	SHEET OF

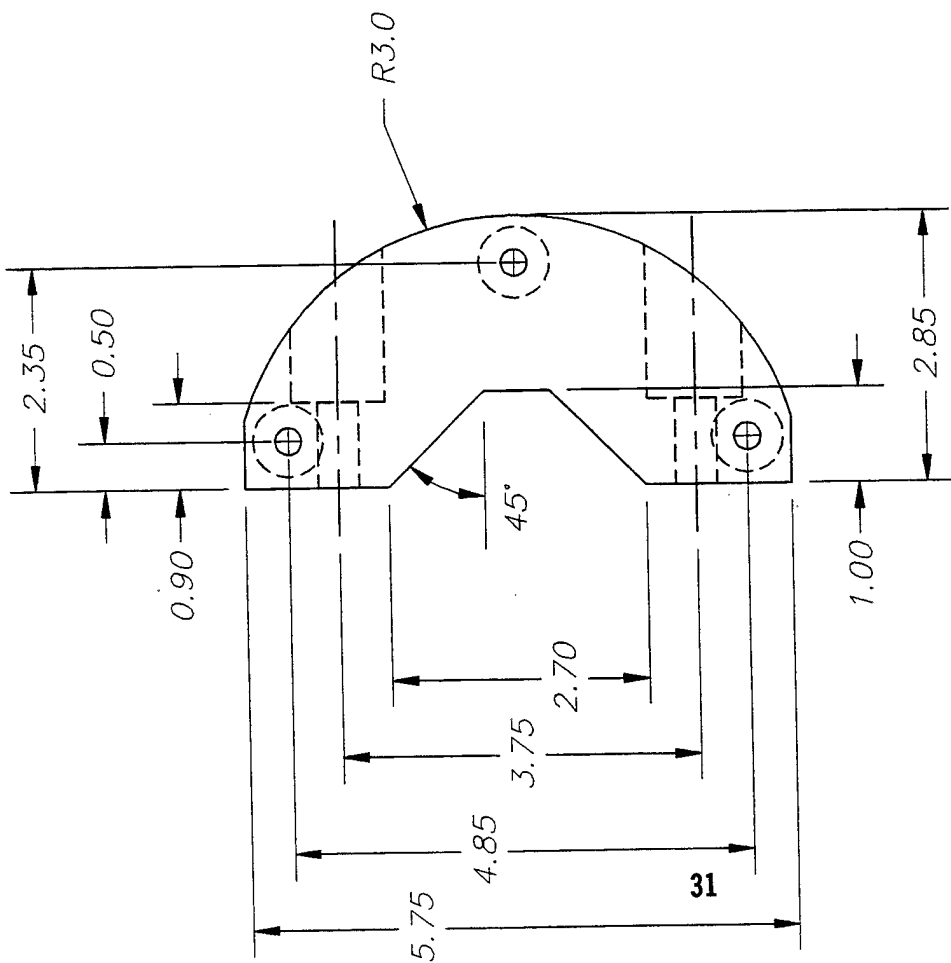

9/32 DRILL THRU
3/4 CB 1.0 DP
3 PLACES

7/16 DRILL THROUGH
Ø1.0 CB AS SHOWN
2 PLACES

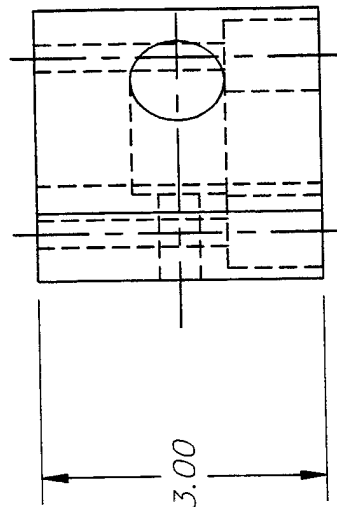
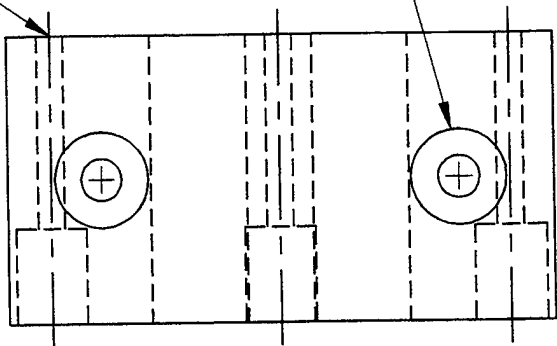

UNLESS OTHERWISE SPECIFIED DIMENSIONS ARE IN INCHES TOLERANCES DECIMALS ±.005 ANGULAR ±1° XX-4 UNLESS NOTED DO NOT SCALE DRAWING	PROJECT NO. 156077.00	DATE 09/19/97	TITLE AOSN VEHICLE DOCK DOCKING SKIRT CLAMP RING
	DRAWN DON PETERS	CHECK	
MATERIAL ACETAL	SIZE 049-2-0300	RELEASE DATE	SHEET OF
FINISH AS NOTED	SCALE		

WOODS HOLE OCEANOGRAPHIC INSTITUTION
APPLIED OCEAN PHYSICS & ENGINEERING
WOODS HOLE, MASSACHUSETTS, 02543

13/32 DRILL THRU
 31/64 DRILL 0.6 DP
 9/16-12 BOTTOM TAP 0.6 DP
 FROM EXISTING CB - 3PL

NO. 7 DRILL THRU
 1/4-20 UNDERSIZE
 TAP THRU - 4PL

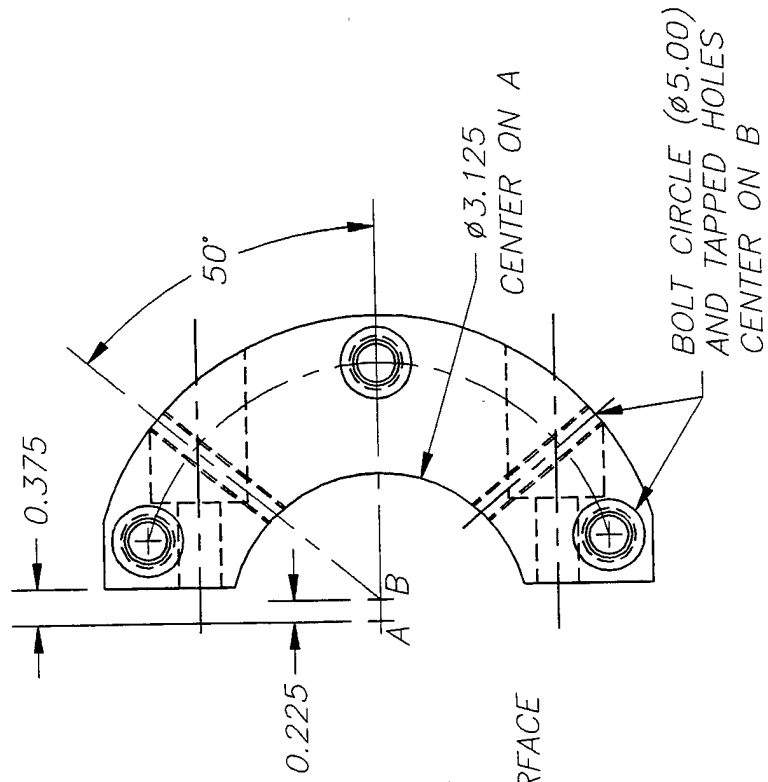
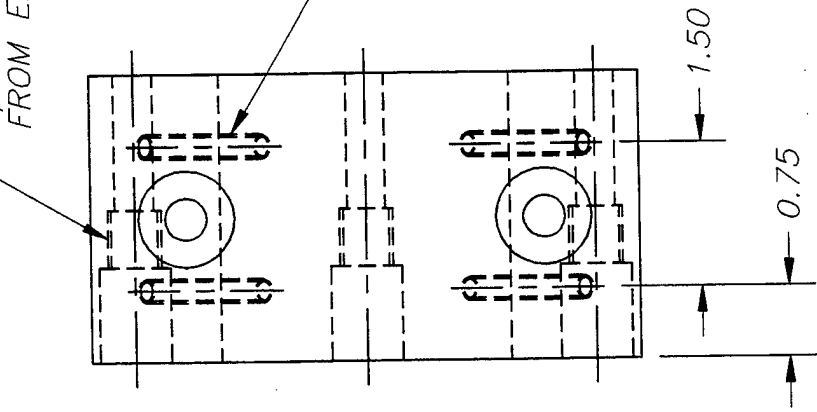

NOTE:
 A = CENTER OF INSIDE BORE
 B = CENTER OF OUTSIDE SURFACE

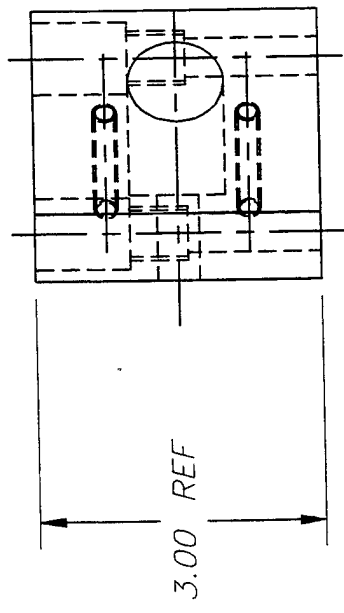

REVISED 01/06/98: ADD'L DIMENSIONS

UNLESS OTHERWISE SPECIFIED DIMENSIONS ARE IN INCHES DECIMALS .XX ±0.1 ANGULAR ±1° .XXX ±0.005 DIM NOT SCALE DRAWING		PROJECT NO. 150394.01	DATE 09/19/97	VOBBS HOLE OCEANOGRAPHIC INSTITUTION APPLIED OCEAN PHYSICS & ENGINEERING WOODS HOLE, MASSACHUSETTS, 02543
MATERIAL 049-2-0300 SKIRT CLAMP		DRAWN DON PETERS	CHECK DON PETERS	
FINISH AS NOTED		SCALE		SIZE DWG NO. 049-2-0301
		RELEASE DATE		SHEET OF

DWG #049-3-0201

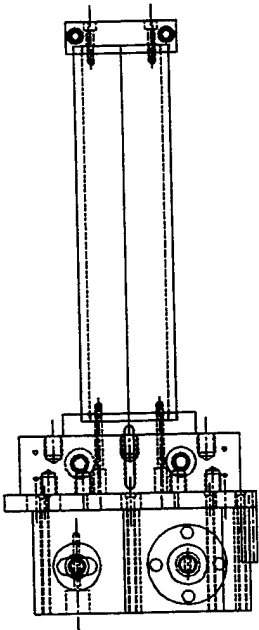

DWG #049-3-0301

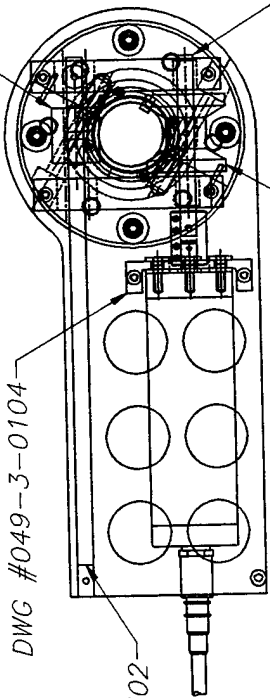

DWG #049-3-0104

DWG #049-3-0302

DWG #049-3-0200

DWG #049-3-0102

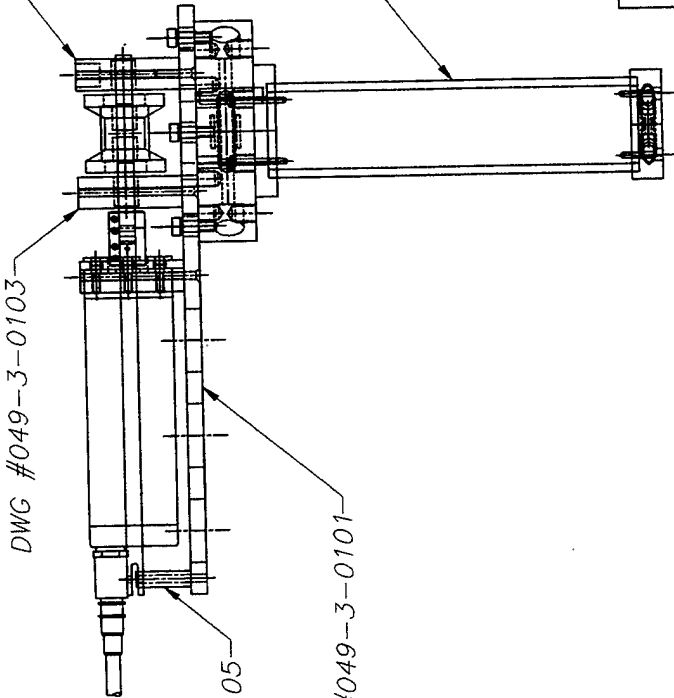

DWG #049-3-0103

DWG #049-3-0105

DWG #049-3-0101

DWG #049-3-0500

UNLESS OTHERWISE SPECIFIED DIMENSIONS ARE IN INCHES TOLERANCES DECIMALS ±0.005 ANGULAR ±1' XXX ±0.005 DO NOT SCALE DRAWING		PROJECT NO. 000000.00	DATE 09/23/97	VERRIS HOLE OCEANOGRAPHIC INSTITUTION APPLIED OCEAN PHYSICS & ENGINEERING VERRIS HOLE, MASSACHUSETTS, 02543
DRAWN DON PETERS	CHECK	TITLE AOSN VEHICLE DOCK CARRIAGE		
MATERIAL AS NOTED	FINISH AS NOTED	DWG NO. 049-3-0000	SCALE RELEASE DATE	SHEET OF

17/32 DRILL THROUGH
COUNTERBORE AS SHOWN

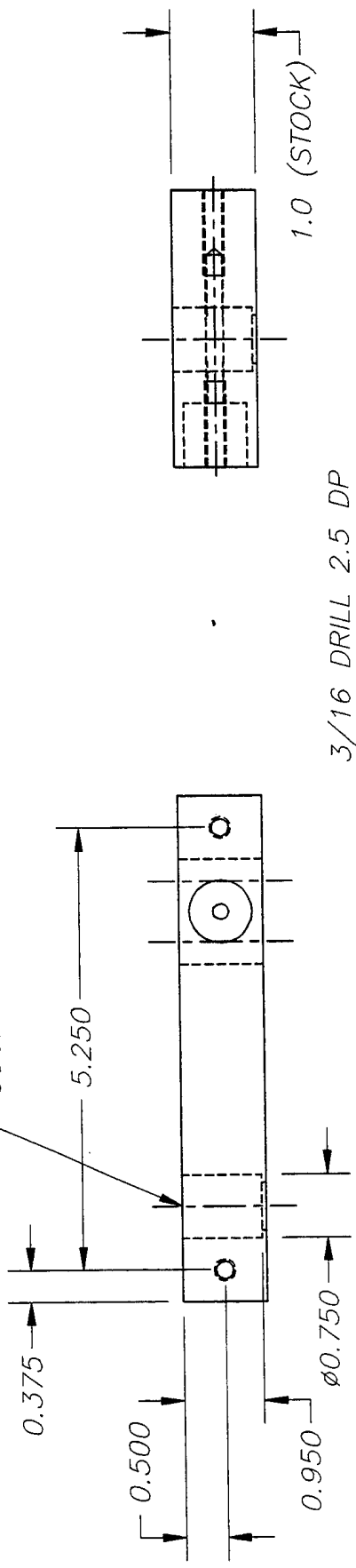

3/16 DRILL 2.5 DP
Ø3/4 COUNTERBORE 0.75

NO. 7 DRILL THROUGH
1/4-20 TAP 1.0 DP EA SIDE

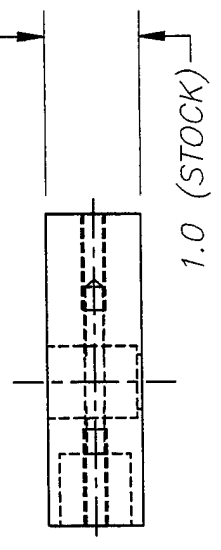
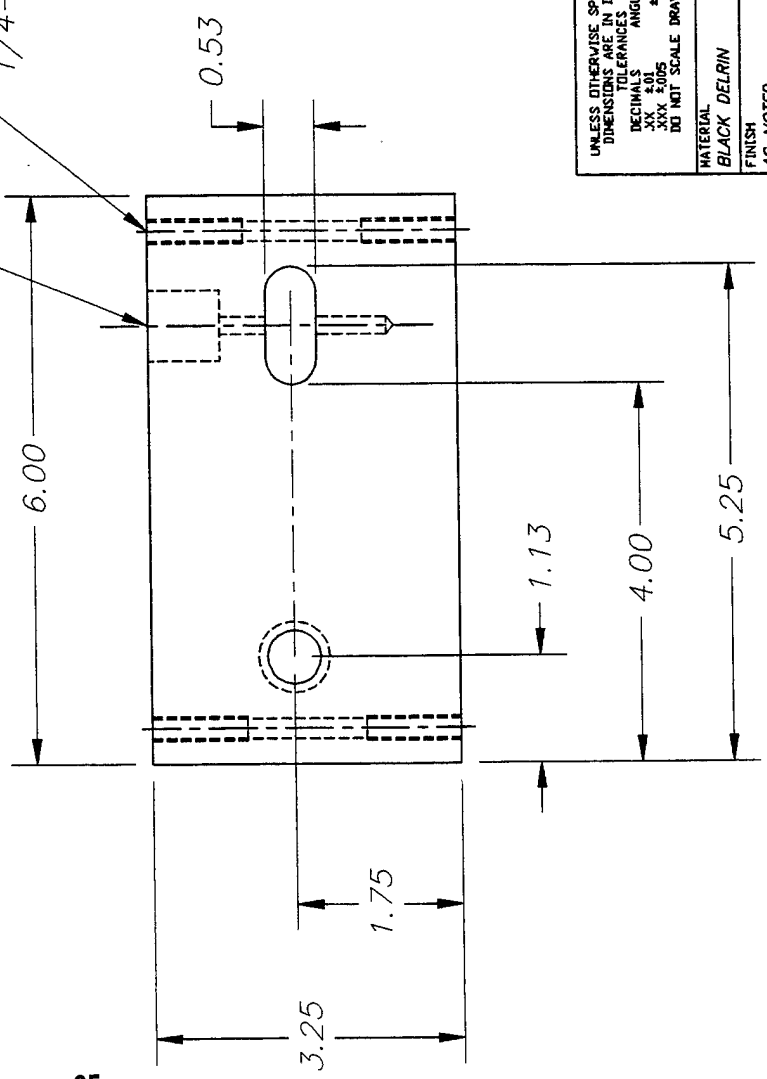

35

UNLESS OTHERWISE SPECIFIED DIMENSIONS ARE IN INCHES TOLERANCES DECIMALS XX ±.01 XXX ±.05 DO NOT SCALE DRAWING		PROJECT NO. 156077.00		VIDDIS HOLE OCEANOGRAPHIC INSTITUTION APPLIED OCEAN PHYSICS & ENGINEERING VIDDIS HOLE, MASSACHUSETTS, 02543	
MATERIAL BLACK DELRIN		DATE 09/22/97	TITLE AOSN VEHICLE DOCK BEARING BLOCK 1		
FINISH AS NOTED		DRAWN DON PETERS	SIZE	DWG NO. 049-3-0102	SHEET OF
		CHECK	SCALE	RELEASE DATE	

17/32 DRILL THROUGH
COUNTERBORE AS SHOWN

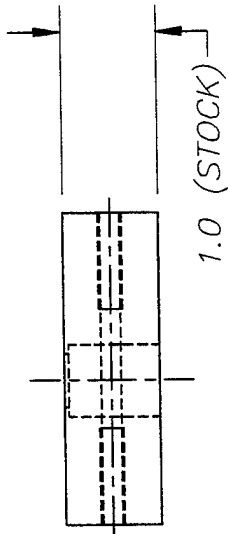
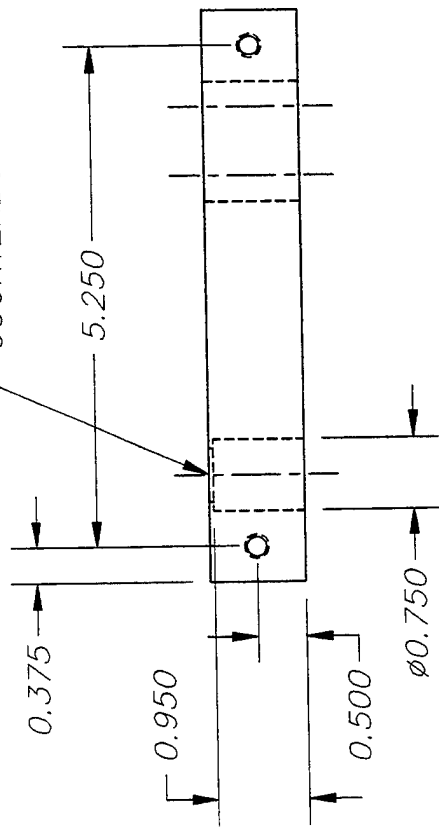

NO. 7 DRILL THROUGH
1/4-20 TAP 1.0 DP EA SIDE

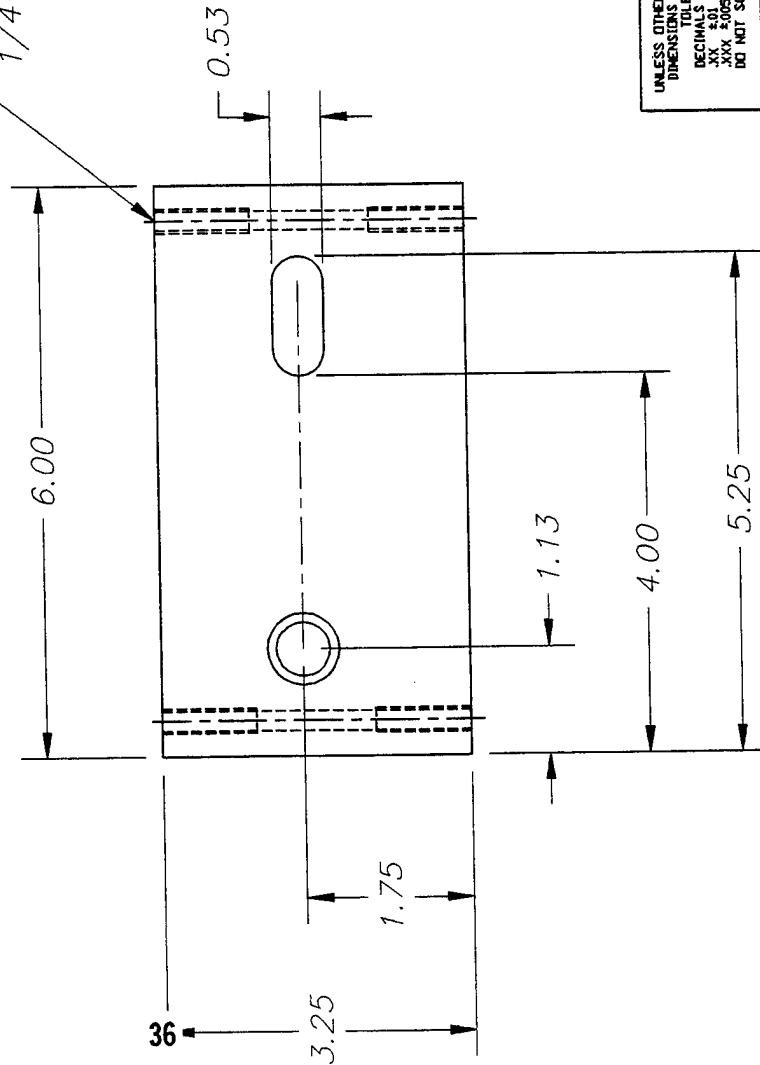

UNLESS OTHERWISE SPECIFIED DIMENSIONS ARE IN INCHES DECIMALS ANGULAR .XX ±0.1 .XXX ±0.005 DO NOT SCALE DRAWING		PROJECT NO. 156077.00	VOODIS HOLE GEOGRAPHIC INSTITUTION APPLIED OCEAN PHYSICS & ENGINEERING VOODIS HOLE, MASSACHUSETTS, 02543	
DRAWN DON PETERS		DATE 09/22/97	TITLE AOSN VEHICLE DOCK BEARING BLOCK 2	
CHECK			SIZE DWG IN.	049-3-0103
MATERIAL BLACK DELRIN			SCALE	RELEASE DATE
FINISH AS NOTED				SHEET OF

NO. 7 DRILL THROUGH
1/4-20 TAP 1.0 DP EA END

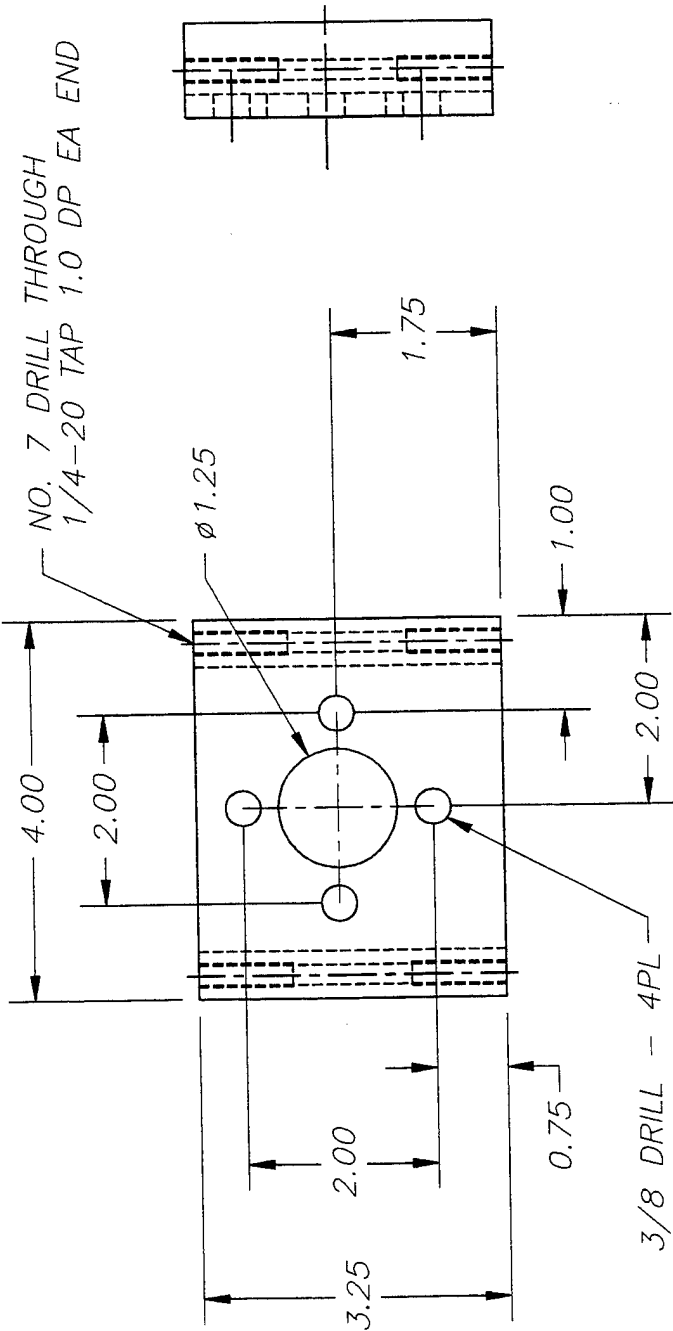

3/8 DRILL - 4PL

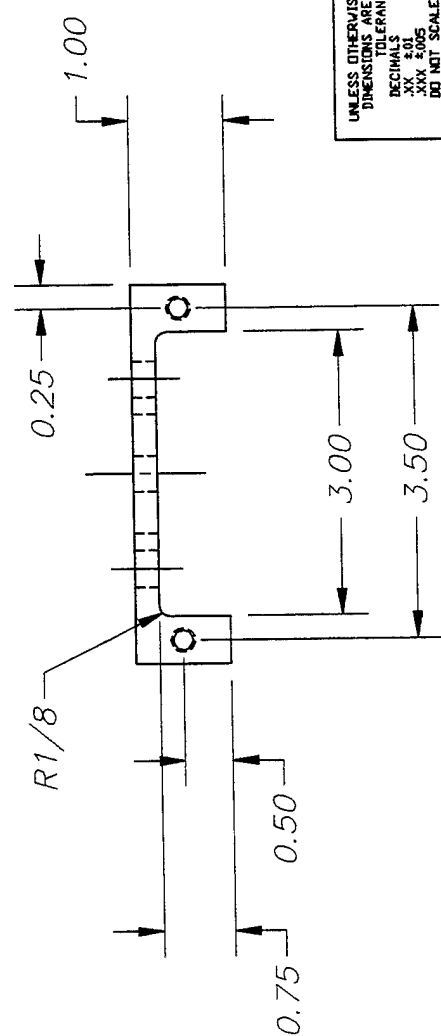

UNLESS OTHERWISE SPECIFIED DIMENSIONS ARE IN INCHES TOLERANCES DECIMALS .XX ±.01 .XXX ±.005 DO NOT SCALE DRAWING		PROJECT NO. 156077.00	DATE 09/22/97	VOODS HOLE OCEANOGRAPHIC INSTITUTION APPLIED OCEAN PHYSICS & ENGINEERING WOODS HOLE, MASSACHUSETTS, 02543
MATERIAL BLACK DELRIN	FINISH AS NOTED	DRAWN DON PETERS	CHECK	TITLE AOSN VEHICLE DOCK MOTOR MOUNT BLOCK
				SIZE DVG N1 049-3-0104
				SCALE RELEASE DATE SHEET 01 OF 01

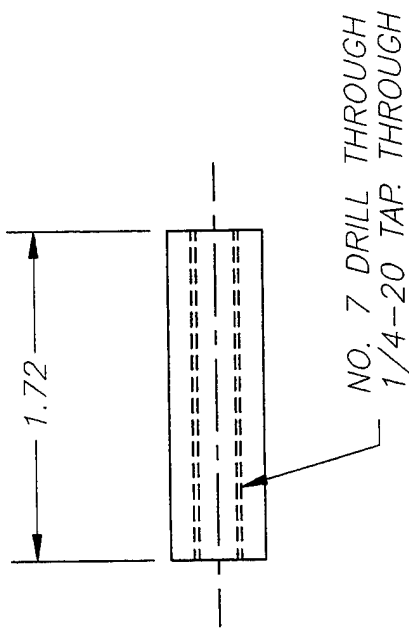

Ø0.50 STOCK

UNLESS OTHERWISE SPECIFIED DIMENSIONS ARE IN INCHES TOLERANCES DECIMALS ±0.01 .XX ±0.01 .XXX ±0.005 DO NOT SCALE DRAWING		PROJECT NO. 156077.00	VVOIDS WHELE OCEANOGRAPHIC INSTITUTION APPLIED OCEAN PHYSICS & ENGINEERING VVOIDS WHELE, MASSACHUSETTS, 02543
DRAWN DON PETERS	DATE 09/22/97	TITLE AOSN VEHICLE DOCK SPRING POST	
CHECK	SCALE	DWG NO. 049-3-0105	RELEASE DATE
MATERIAL 6061-T6 ALUMINUM	FINISH AS NOTED	SHEET	OF

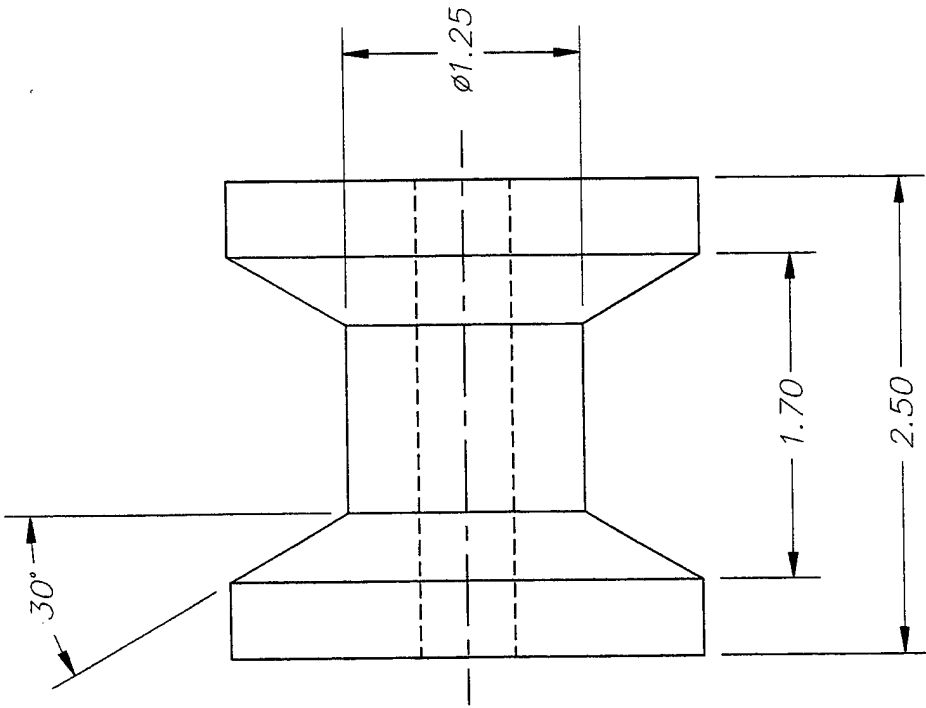

$\phi 2.50$ STOCK

$\phi 0.50$ STOCK

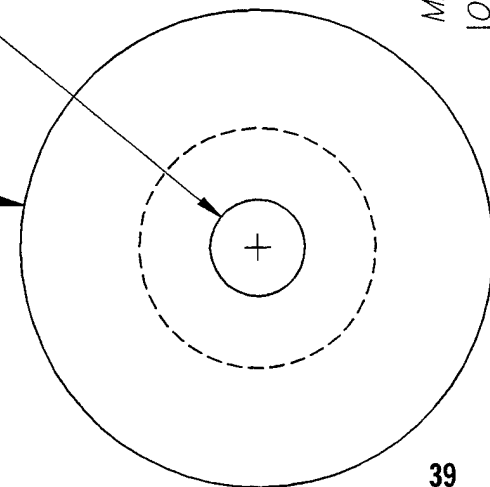

MAKE FOUR PIECES
ONE PIECE:
1/32 KERF RADIAL
CUT 0.4 DEEP
EQUALLY SPACED
AT 15° - 24PL

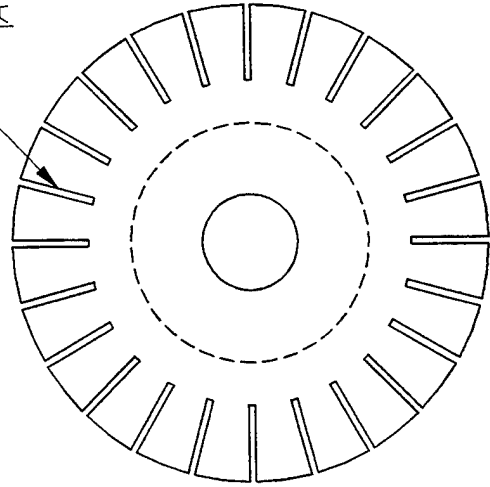

UNLESS OTHERWISE SPECIFIED DIMENSIONS ARE IN INCHES TOLERANCES		PROJECT NO. 156168.08	VOIDS HOLE OCEANOGRAPHIC INSTITUTION APPLIED OCEAN PHYSICS & ENGINEERING WOODS HOLE, MASSACHUSETTS, 02543	
DECIMALS .XX ±.01	ANGULAR ±1'	DRAWN DON PETERS	TITLE ODYSSEY DOCKING FIXTURE FRICTION DRIVE WHEEL	
XXX ±.005	DO NOT SCALE DRAWING	DATE 09/19/97	SIZE DWG INL	RELEASE DATE 049-3-0200
MATERIAL URETHANE WHEEL STOCK		CHECK	SCALE	SHEET OF
FINISH AS NOTED				

17/32 DRILL THROUGH

Ø 1.50 STOCK

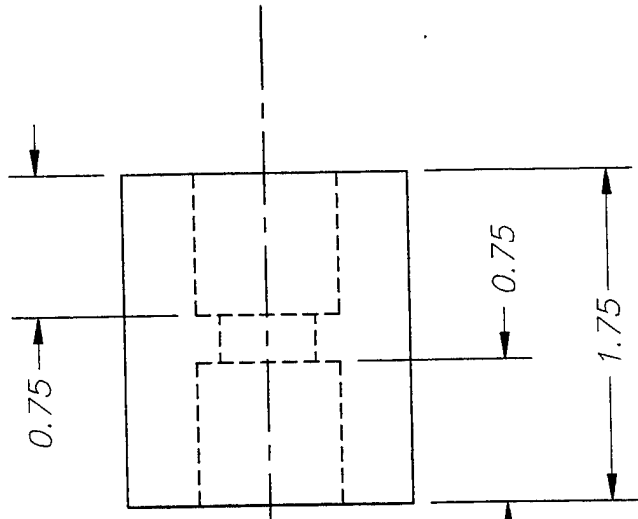
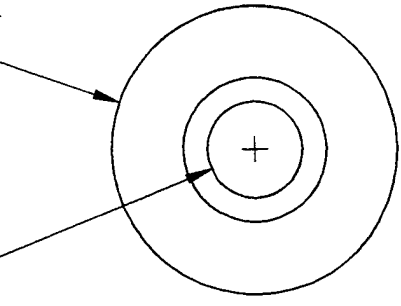

$\phi 0.750^{+0.001}_{-0.003}$

40

UNLESS OTHERWISE SPECIFIED DIMENSIONS ARE IN INCHES DECIMALS ±0.01 ANGULAR ±1° .XXX ±0.005 DO NOT SCALE DRAWING		PROJECT NO. 156077.00	DATE 09/22/97	VIDDIS HOLE OCEANOGRAPHIC INSTITUTION APPLIED OCEAN PHYSICS & ENGINEERING VIDDIS HOLE, MASSACHUSETTS, 02543
MATERIAL WHITE DELRIN	DRAWN DON PETERS	CHECK	TITLE AOSN VEHICLE DOCK IDLER WHEEL	SCALE
FINISH AS NOTED	SIZE	DWG NO. 049-3-0201	RELEASE DATE	SHEET OF

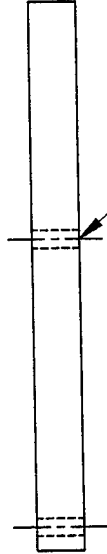
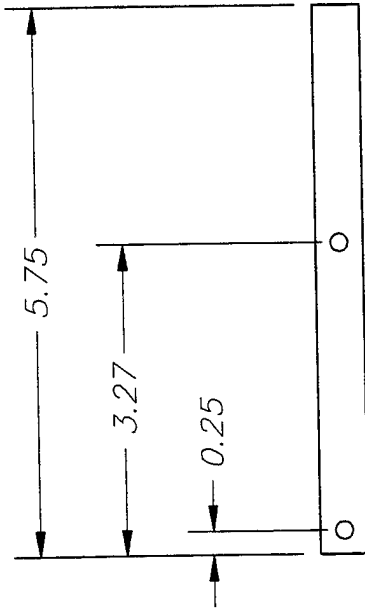

3/16 DRILL THROUGH - 2PL



UNLESS OTHERWISE SPECIFIED DIMENSIONS ARE IN INCHES DECIMALS .XX ±0.1 .XXX ±0.05 ANGULAR ±1° DO NOT SCALE DRAWING		PROJECT NO. 156077.00	DATE 09/22/97	VOODS HOLE OCEANOGRAPHIC INSTITUTION APPLIED OCEAN PHYSICS & ENGINEERING VOODS HOLE, MASSACHUSETTS, 02543
MATERIAL 1/2 ROUND BAR 316SS	DRAWN DON PETERS	CHECK	TITLE AOSN VEHICLE DOCK DRIVE SHAFT	DWG NO. 049-3-0301
FINISH AS NOTED	SCALE	RELEASE DATE	SHEET	OF

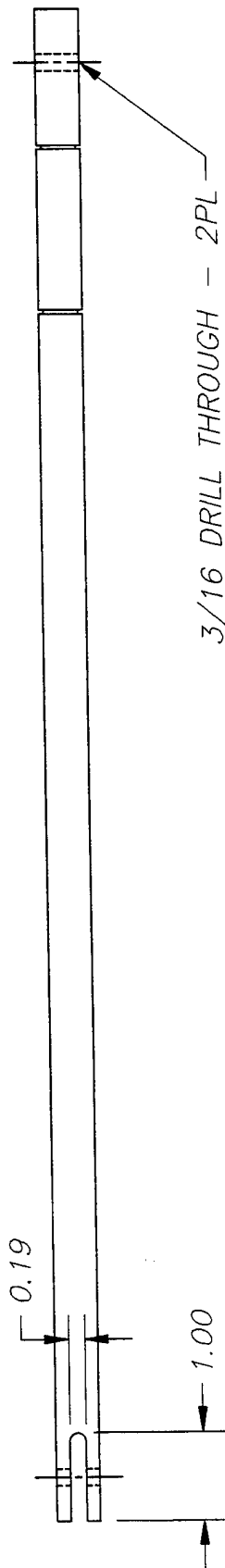
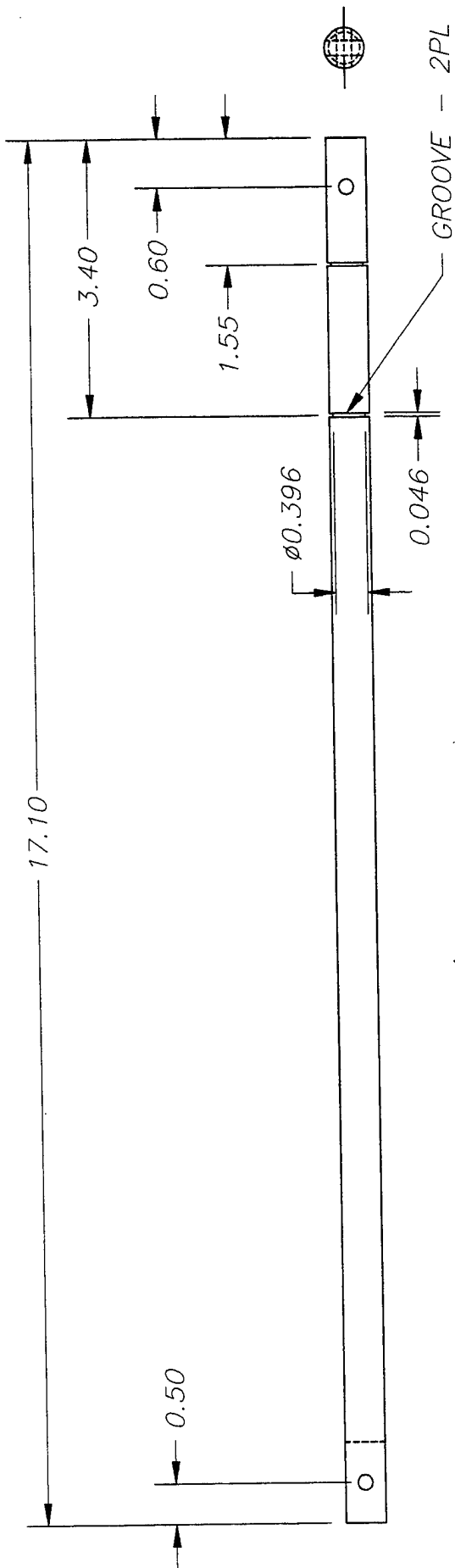

3/16 DRILL THROUGH - 2PL

UNLESS OTHERWISE SPECIFIED DIMENSIONS ARE IN INCHES TOLERANCES DECIMALS ±0.005 XX ±0.01 XXX ±0.015 DO NOT SCALE DRAWING	PROJECT NO.	VIDEOS FILE OCEANOGRAPHIC INSTITUTION APPLIED OCEAN PHYSICS & ENGINEERING VIDDIS HOLE, MASSACHUSETTS, 02543	
	156077.00	TITLE	
DRAWN	DATE	AOSN VEHICLE DOCK IDLER SHAFT	
DON PETERS	09/22/97	SIZE	DWG NO.
CHECK		SCALE	049-3-0302
MATERIAL		RELEASE DATE	SHEET
1/2 ROUND BAR 316SS			OF
FINISH			
AS NOTED			

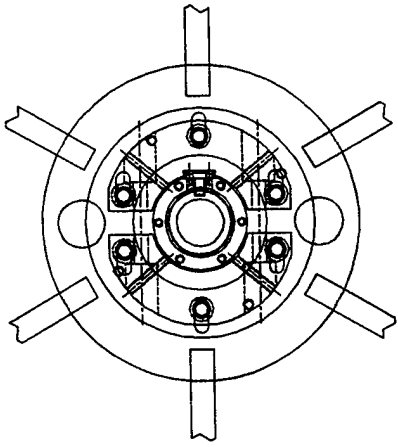

DWG #049-3-0402

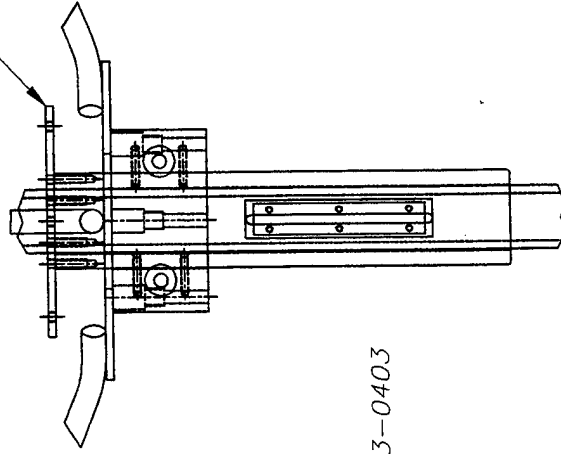

DWG #049-3-0403

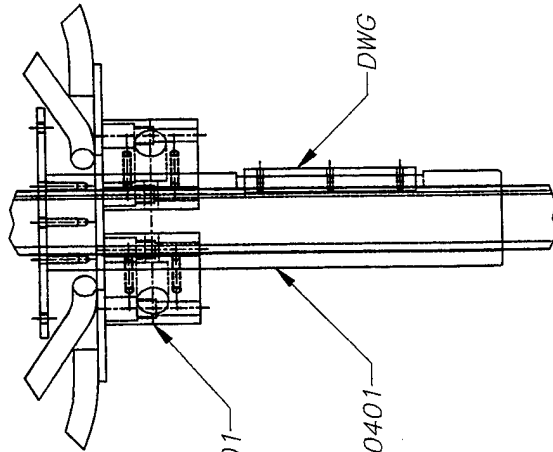

DWG #049-2-0301

DWG #049-3-0401

UNLESS OTHERWISE SPECIFIED DIMENSIONS ARE IN INCHES TOLERANCES DECIMALS .XX ±.01 .XXX ±.005 DO NOT SCALE DRAWING		PROJECT NO. 156077.00 DRAWN DON PETERS CHECK	DATE 09/22/97	VERRIS HOLE OCEANOGRAPHIC INSTITUTION APPLIED OCEAN PHYSICS & ENGINEERING VERRIS HOLE, MASSACHUSETTS, 02543
MATERIAL AS NOTED		TITLE AOSN VEHICLE DOCK SLIDER ASSEMBLY		SCALE 1" = 1"
FINISH AS NOTED		SIZE DWG NO. 049-3-0400		SHEET 01 OF

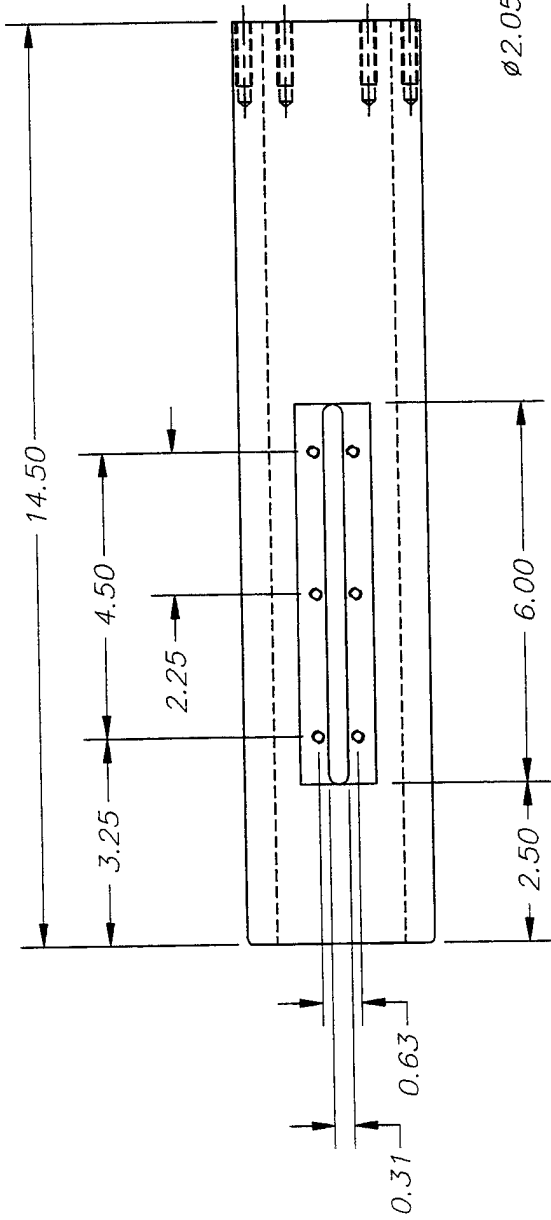

44

NO. 21 DRILL THRU
TAP 10-32 - 6PL

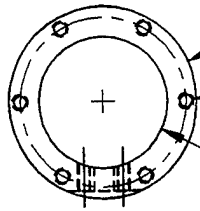
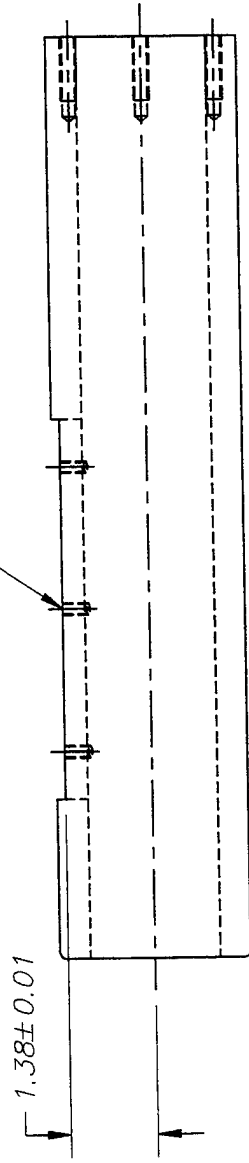

$\phi 2.05 \pm 0.01$

$\phi 3.0$ (STOCK)

NO. 7 DRILL 1.25 DP
TAP 1/4-20 1.0 DP MIN
6PL@60° ON $\phi 2.65$ BC

UNLESS OTHERWISE SPECIFIED DIMENSIONS ARE IN INCHES		PROJECT NO. 156077.00	WOODS HOLE OCEANOGRAPHIC INSTITUTION APPLIED OCEAN PHYSICS & ENGINEERING WOODS HOLE, MASSACHUSETTS 02543	
DECIMALS .XX ±0.01	ANGULAR ±1°	DRAWN DON PETERS	DATE 09/22/97	TITLE AOSN VEHICLE DOCK SLIDER HUB
.XXX ±0.005	DO NOT SCALE DRAWING	CHECK		SIZE DWG IN: 049-3-0401
MATERIAL 3 OD X 2 ID UHMW	FINISH AS NOTED			SCALE RELEASE DATE
				SHEET OF

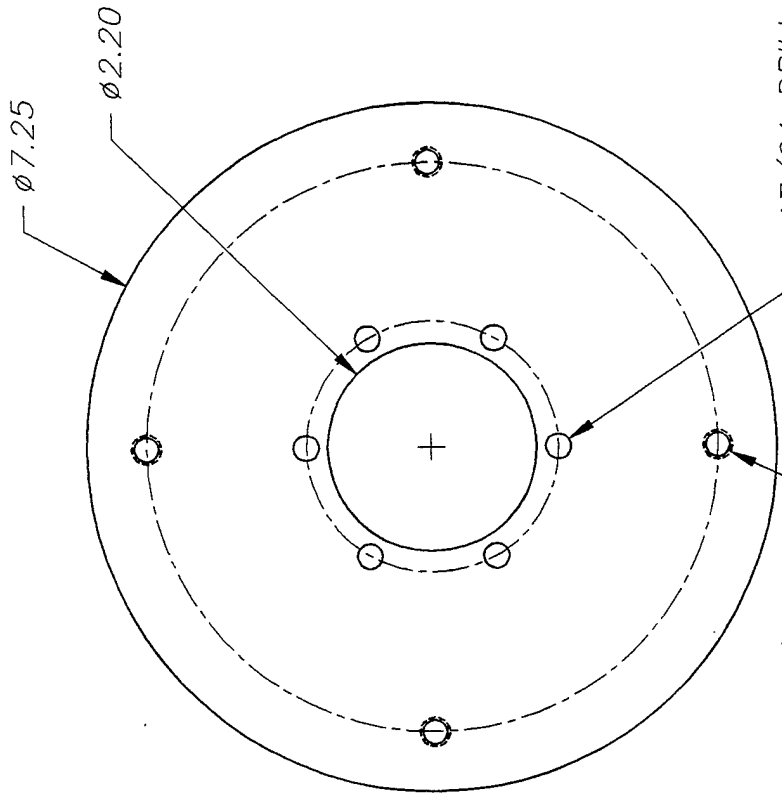

17/64 DRILL THRU
6PL @60°
ON $\phi 2.65$ BC

LET. F DRILL THRU
TAP 5/16-18 THRU
4PL @90° ON $\phi 6.00$ BC

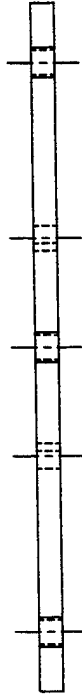
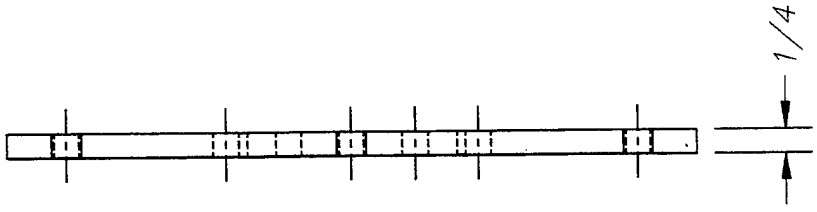

UNLESS OTHERWISE SPECIFIED DIMENSIONS ARE IN INCHES DECIMALS ANGULAR XX ±.01 ±1° XXX ±.005 DO NOT SCALE DRAWING		PROJECT NO. 156077.00	DATE 09/22/97	VIDDIS WILE OCEANOGRAPHIC INSTITUTION APPLIED OCEAN PHYSICS & ENGINEERING VIDDIS HILL, MASSACHUSETTS, 02543
MATERIAL	DELFIN	DRAWN	DON PETERS	TITLE
FINISH	AS NOTED	CHECK		AOSN VEHICLE DOCK SLIDER FLANGE PLATE
				SIZE
				DWG NO.
				049-3-0402
				RELEASE DATE
				SHEET
				OF

17/64 DRILL - 6PL

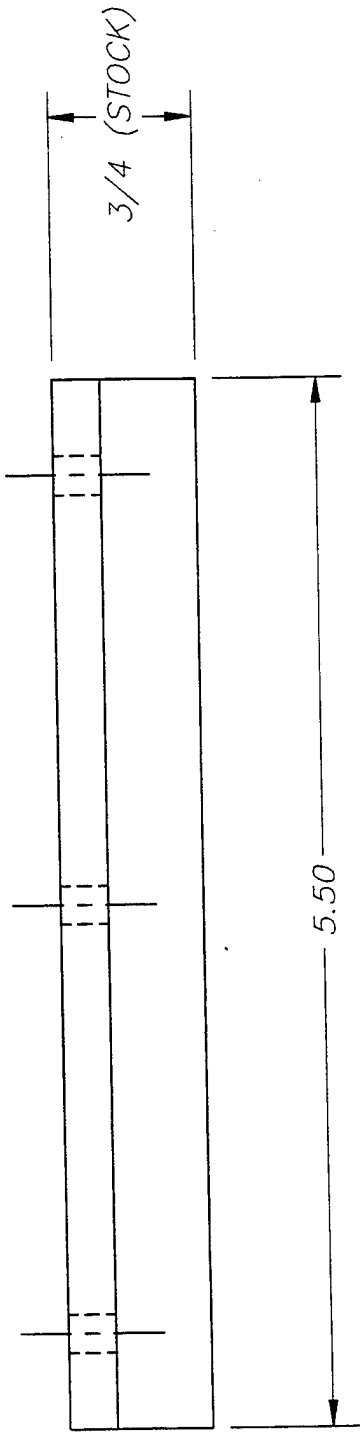
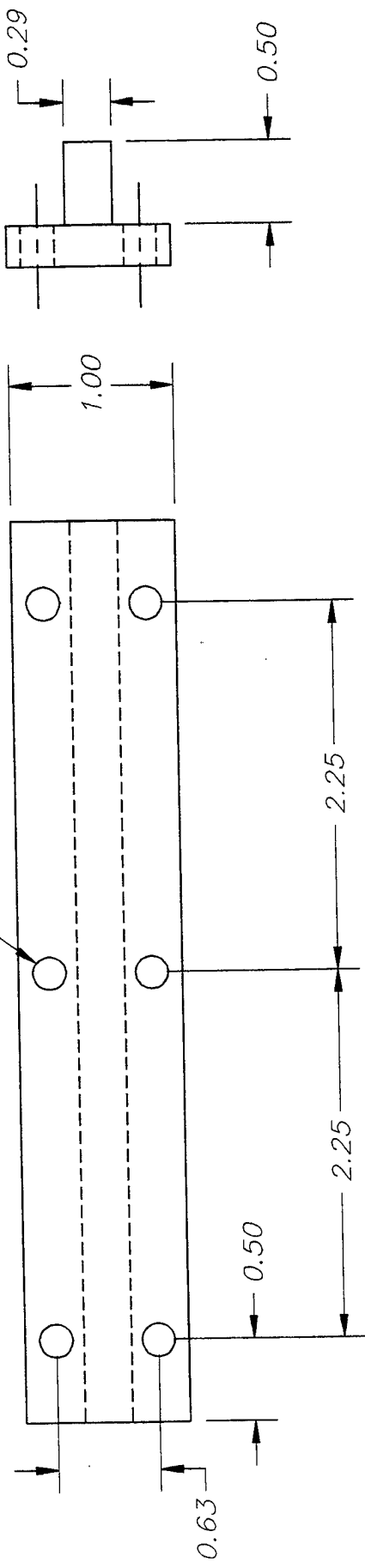

UNLESS OTHERWISE SPECIFIED DIMENSIONS ARE IN INCHES TOLERANCES DECIMALS .XX ±.01 .XXX ±.005 ANGULAR ±1° DO NOT SCALE DRAWING		PROJECT NO. 156188.08	DATE 09/22/97	TITLE AOSN VEHICLE DOCK SLIDER KEY BLOCK	VOBBS HOLE OCEANOGRAPHIC INSTITUTION APPLIED OCEAN PHYSICS & ENGINEERING WOODS HOLE, MASSACHUSETTS, 02543
DRAWN DON PETERS	CHECK	DVG NO. 049-3-0403	SCALE	SHEET OF	RELEASE DATE
MATERIAL DELFRIN	FINISH AS NOTED	SIZE	SCALE	SHEET OF	RELEASE DATE

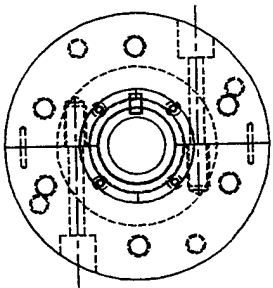

DWG #049-3-0501

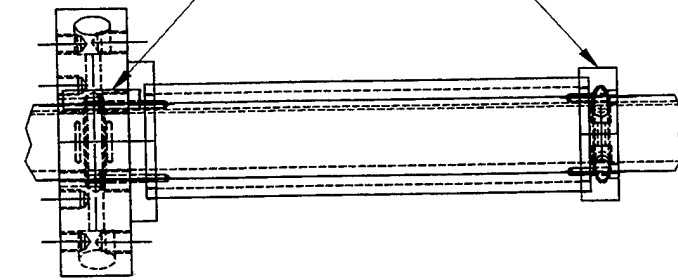

DWG #049-3-0504

DWG #049-3-0502

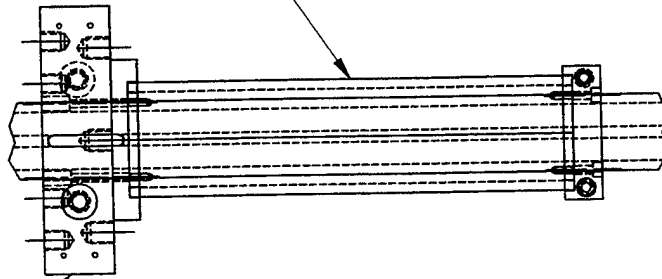

DWG #049-3-0503

UNLESS OTHERWISE SPECIFIED DIMENSIONS ARE IN INCHES TOLERANCES DECIMALS ±.005 ANGULAR ±1° XXX ±.005 DO NOT SCALE DRAWING		PROJECT NO. 756768-08	DATE 09/22/97	VODDS HOLE OCEANOGRAPHIC INSTITUTION APPLIED OCEAN PHYSICS & ENGINEERING VODDS HOLE, MASSACHUSETTS 02543	
MATERIAL AS NOTED		DRAWN C. LUMPING	CHECK	TITLE AOSN VEHICLE DOCK SLIDER ASSEMBLY	
FINISH AS NOTED				SCALE	SHEET 0F 2
				DWG NO. 049-3-0500	RELEASE DATE

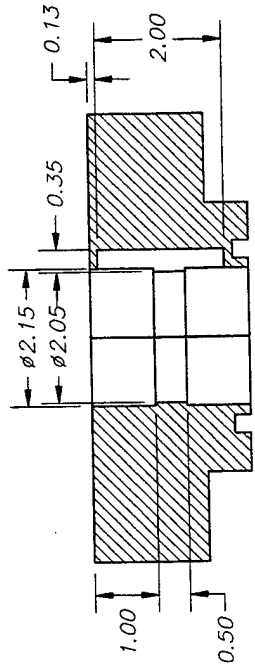

CROSS SECTION OF LEFT VIEW

CENTER CUT FOR TWO SEPARATE PIECES

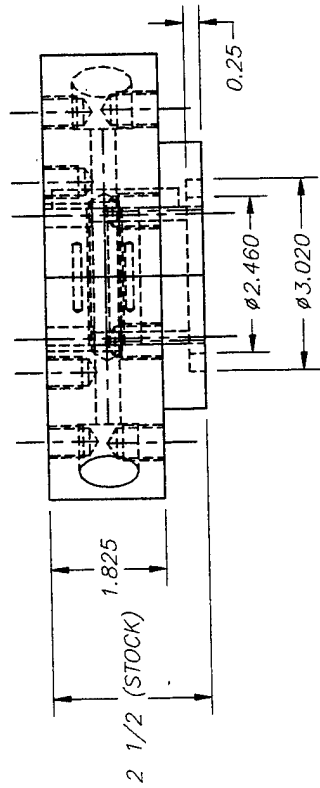

27/64 DRILL 0.80 DP
TAP FOR 1/2-13 0.60 DP
4 PLACES @90° ON 6.00 BC
TOP SIDE ONLY

31/64 DRILL 0.90 DP
TAP FOR 9/16-12 0.70 DP
6 PLACES
BOTTOM SIDE ONLY

LET. W DRILL THROUGH
15/16 COUNTERBORE 1.00 DP
2 PLACES AS SHOWN

NO. 6 DRILL THROUGH
3/8 COUNTERBORE 3/4 DP
4 PLACES

31/64 DRILL 1.40 DP
TAP FOR 9/16-12 1.10 DP
2 PLACES AS SHOWN

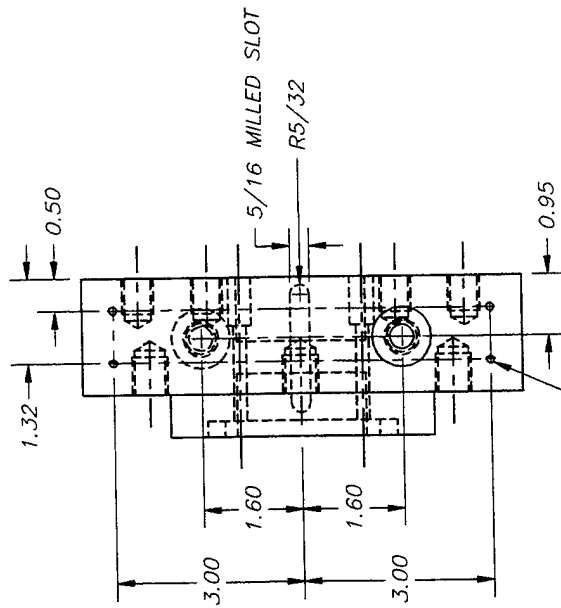

1/8 DRILL 0.55 DP
4 PLACES
FROM INSIDE OF EACH HALF
FOR PIN

REV 05/15/98 - Ø2.15 I.D.

UNLESS OTHERWISE SPECIFIED DIMENSIONS ARE IN INCHES TOLERANCES		PROJECT NO. 156168.08	VUDDS HOLE OCEANOGRAPHIC INSTITUTION APPLIED OCEAN PHYSICS & ENGINEERING WOODS HOLE, MASSACHUSETTS, 02543	
DECIMALS .XX ±0.1	ANGULAR ±1°	DRAWN C. LUMPING	TITLE AOSN VEHICLE DOCK SLIDER UPPER ATTACHMENT	
XXX 5.005	DO NOT SCALE DRAWING	CHECK	DATE 03/30/98	SIZE DWG NO. 049-3-0501
MATERIAL 2 1/2' ACETAL SHEET	FINISH AS NOTED		RELEASE DATE	SHEET OF

NOTE: DIMENSIONS CORRECT AFTER CUT

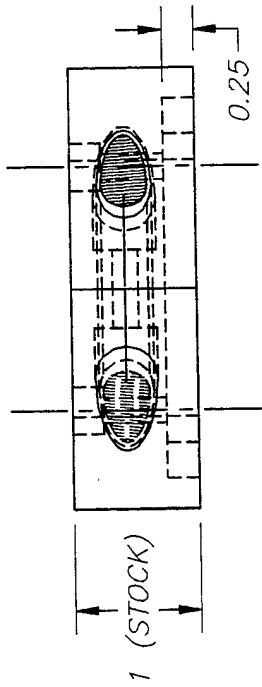

CENTER CUT FOR
TWO SEPARATE PIECES

LET. U DRILL THROUGH
TAP FOR 7/16-14
2 PLACES AS SHOWN

17/64 DRILL THROUGH
1/2 COUNTERBORE 1.00 DP
2 PLACES AS SHOWN

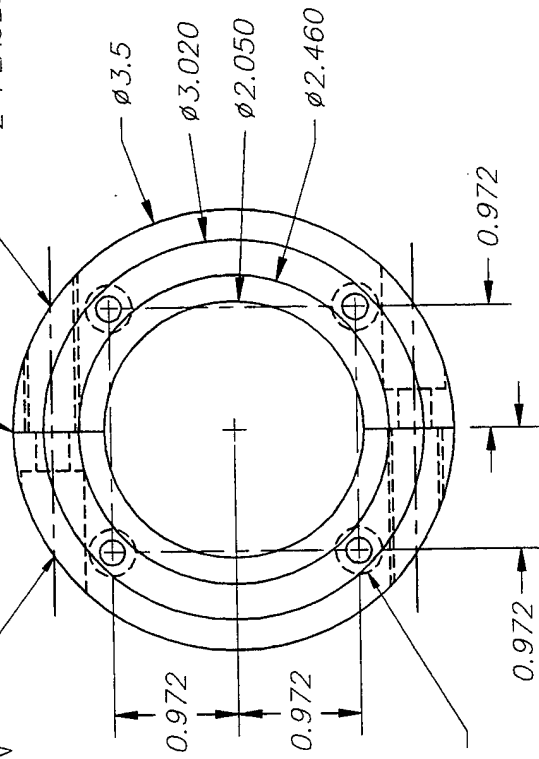

NO. 6 DRILL THROUGH
3/8 COUNTERBORE 0.25 DP
4 PLACES

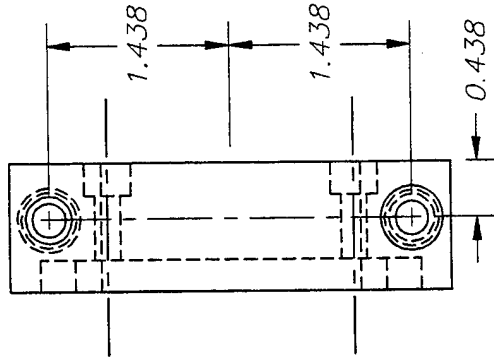

REV 04/24/98 - 2.080 I.D.

NOTE: DIMENSIONS CORRECT AFTER CUT

UNLESS OTHERWISE SPECIFIED DIMENSIONS ARE IN INCHES		PROJECT NO. 156168.08	VOIDS HOLE OCEANOGRAPHIC INSTITUTION APPLIED OCEAN PHYSICS & ENGINEERING VOIDS HOLE, MASSACHUSETTS, 02543	
TOLERANCES	DATE	DRAWN	TITLE	
DECIMALS	03/30/98	C. LUMPING	AOSN VEHICLE DOCK	
.XX ±.01		CHECK	SLIDER LOWER ATTACHMENT	
.XXX ±.005			SIZE	DWG NO.
DO NOT SCALE DRAWING			SCALE	RELEASE DATE
MATERIAL				SHEET
1" ACETAL SHEET				OF
FINISH				
AS NOTED				

Ø3 OD 1/4 WALL (STOCK)

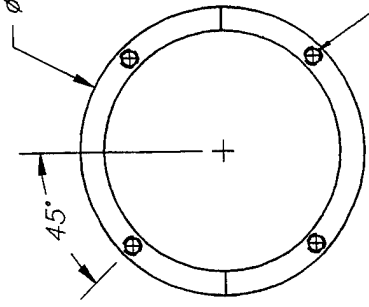

NO. 21 DRILL 0.60 DP
TAP FOR 10-32 0.50 DP
4 PLACES @90°
CENTER ON STOCK
BOTH ENDS

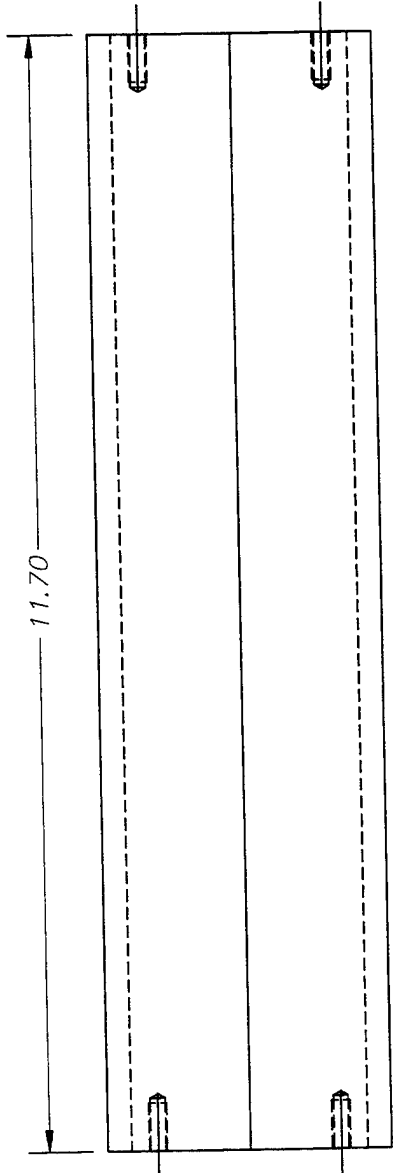

11.70

NOTE: DO NOT CUT TUBE IN HALF
UNTIL HOLES HAVE BEEN DRILLED

UNLESS OTHERWISE SPECIFIED DIMENSIONS ARE IN INCHES TOLERANCES DECIMALS ±0.005 XX ±0.008 XXX ±0.015 DO NOT SCALE DRAWING		PROJECT NO. 156768.08	DATE 03/30/98	WOODS HOLE OCEANOGRAPHIC INSTITUTION APPLIED OCEAN PHYSICS & ENGINEERING WOODS HOLE, MASSACHUSETTS, 02543
MATERIAL 3" OD ALUMINUM TUBE		DRAWN C. LUMPING	CHECK	TITLE AOSN VEHICLE DOCK SLIDER SHAFT
FINISH AS NOTED		SCALE	SIZE DWG NO. 049-3-0503	RELEASE DATE
		SHEET 3	OF 3	OF 3

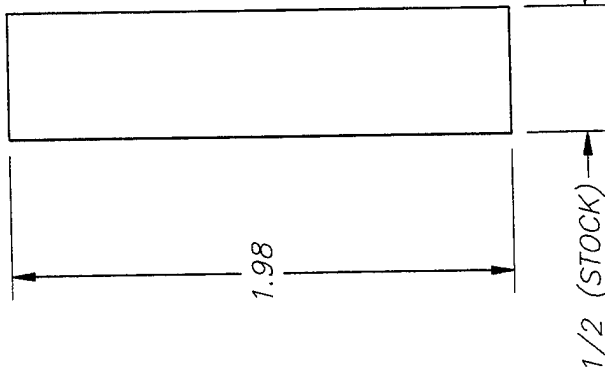
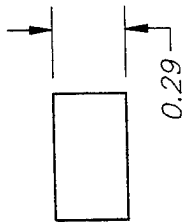

R5/32 (TYP)



UNLESS OTHERWISE SPECIFIED DIMENSIONS ARE IN INCHES TOLERANCES DECIMALS ±0.01 ANGULAR ±1° XXX ±0.005 DO NOT SCALE DRAWING		PROJECT NO. 156168.08	DATE 03/30/98	WOODS HOLE OCEANOGRAPHIC INSTITUTION APPLIED OCEAN PHYSICS & ENGINEERING WOODS HOLE, MASSACHUSETTS 02543
MATERIAL STAINLESS STEEL		DRAWN C. LUMPING	TITLE AOSN VEHICLE DOCK SLIDER KEY INSERT	SIZE DWG NO. 049-J-0504
FINISH AS NOTED		CHECK	SCALE	RELEASE DATE
		SHEET	DF	DF

DWG #049-4-0200
REVISED 09/11/97

DWG #049-4-0201

DWG #049-4-0100
REVISED 09/11/97

DWG #049-4-0301

DWG #049-4-0401

52

DWG #049-4-0302

DWG #049-4-0501

DOCK CONTROLLER INSTRUMENT HOUSING

BATTERY HOUSING
TUBE DWG #049-5-0100
ENDCAP DWG #049-5-0200
MOUNT TAB DWG #049-5-0300 REV 09/11/97

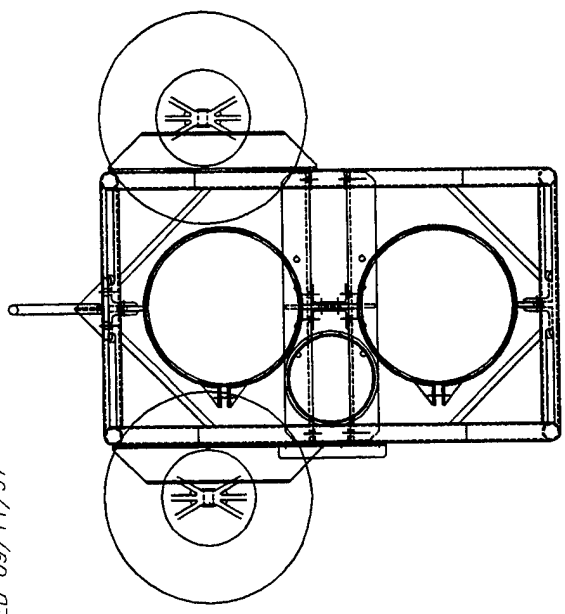

REVISED 10/08/97; INSTRUMENT HOUSING MOUNTS
REVISED 09/26/97; HOUSING BELLY BANDS
REVISED 09/11/97; REVISION NOTES

WOODS HOLE OCEANOGRAPHIC INSTITUTION
APPLIED OCEAN PHYSICS & ENGINEERING
WOODS HOLE, MASSACHUSETTS, 02543

TITLE

AOSN VEHICLE DOCK
BATTERY/INSTRUMENT CAGE

PROJECT NO.

755727.00

DATE

09/02/97

DRAWN

DON PETERS

CHECK

UNLESS OTHERWISE SPECIFIED
DIMENSIONS ARE IN INCHES

TOLERANCES

DECIMALS

.XX ±.01

.XXX ±.005

ANGULAR

±1'

DO NOT SCALE DRAWING

MATERIAL

AS NOTED

FINISH

AS NOTED

SIZE

DWG NO.

049-4-0000

RELEASE DATE

SHEET

OF

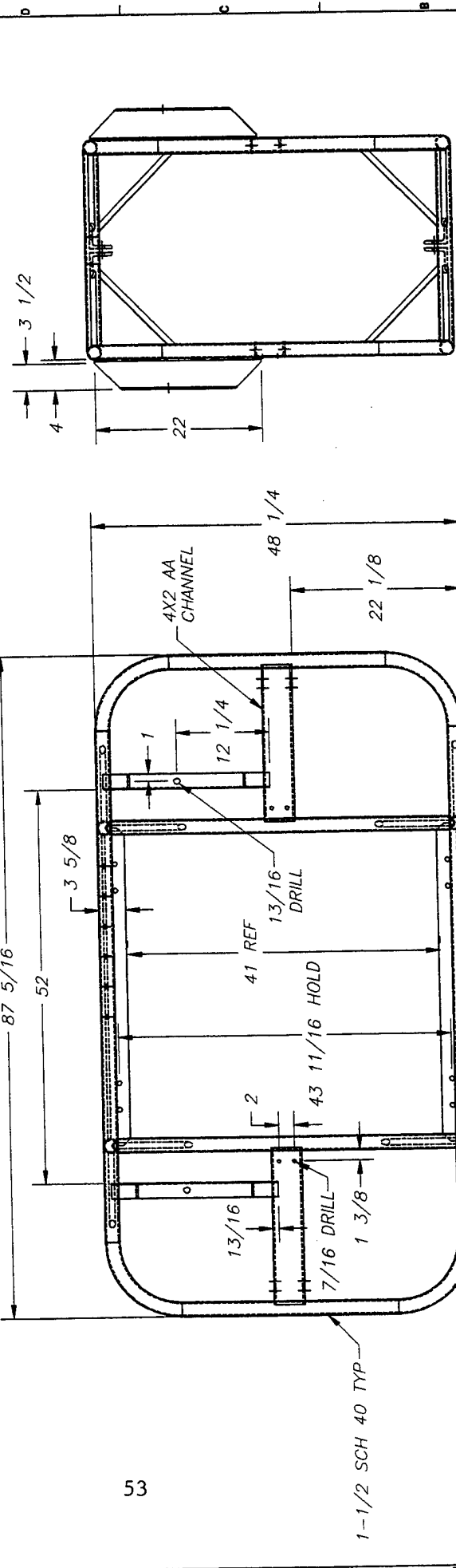
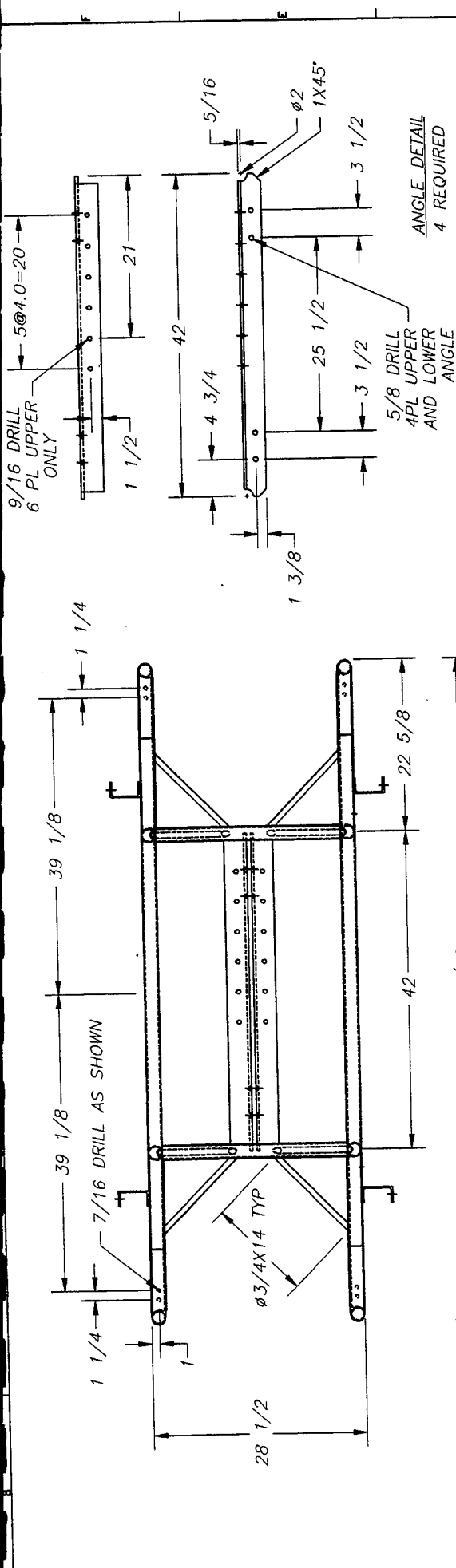

REVISED 10/08/97: INST HSG MOUNT HOLES
 REVISED 10/06/97: POLYFORM MOUNTS
 REVISED 09/11/97: HOUSING MOUNT LOCATIONS

VODDS HILE OCEANOGRAPHIC INSTITUTION
 APPLIED OCEAN PHYSICS & ENGINEERING
 VODDIS HOLE, MASSACHUSETTS, 02543

PROJECT NO.
 155727.00

UNLESS OTHERWISE SPECIFIED
 DIMENSIONS ARE IN INCHES
 DECIMALS 1/100
 ANGULAR 1/4°
 .XX ±0.1
 .XXX ±0.005
 DO NOT SCALE DRAWING

MATERIAL
 ALUMINUM
 FINISH
 AS NOTED

TITLE
 AOSN BATTERY CAGE
 MAIN FRAME WELDMENT

DRAWN
 DON PETERS
 CHECK

DATE
 09/07/97

SIZE
 049-4-0100

SCALE
 RELEASE DATE

SHEET
 OF

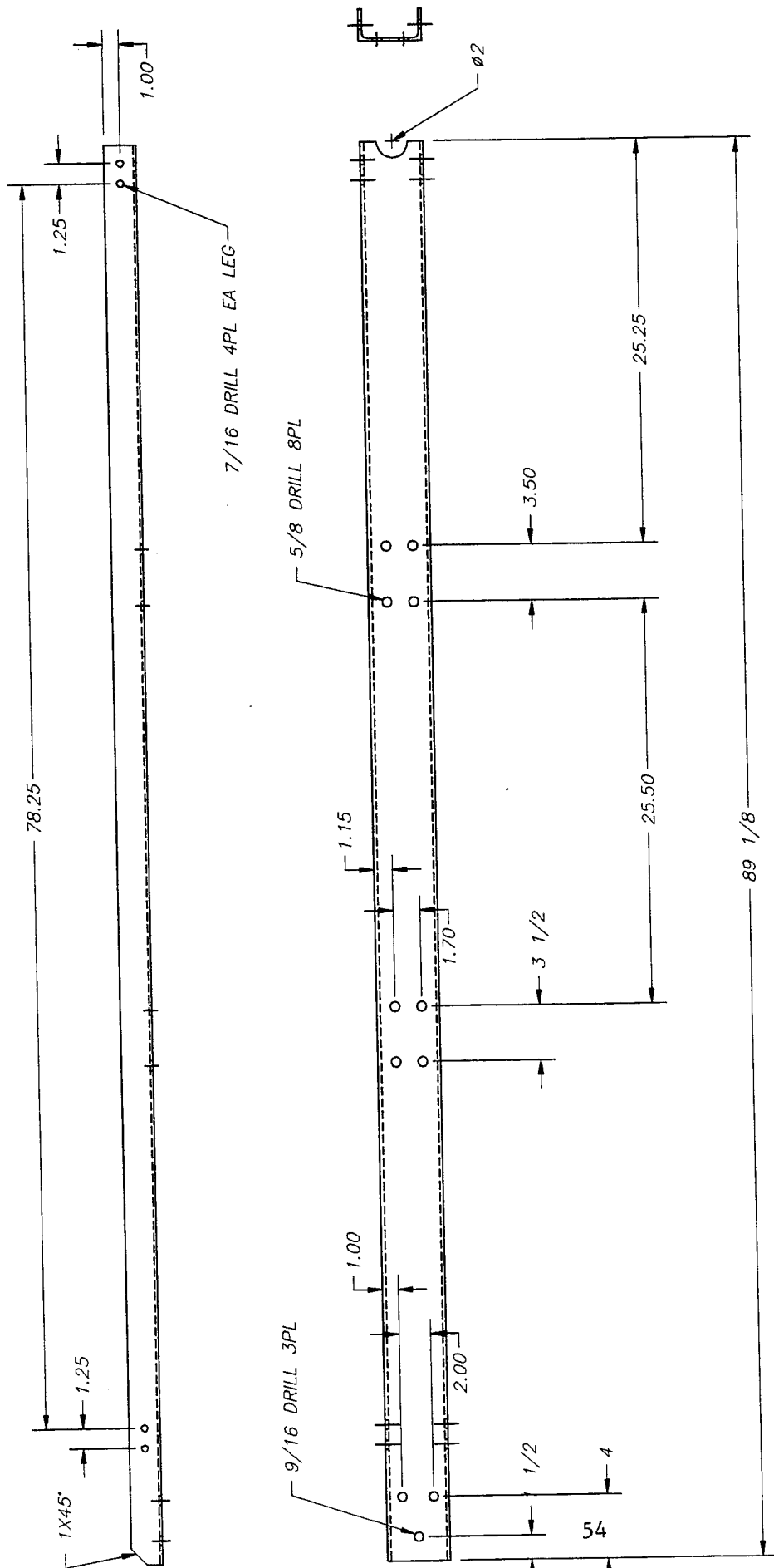

REVISED 09/11/97: MOUNT HOLE LOCATIONS

PROJECT NO. 155727.00		DATE 09/07/97	
DRAWN DON PETERS		CHECK	
UNLESS OTHERWISE SPECIFIED DIMENSIONS ARE IN INCHES DECIMALS ANGULAR .XXX ±.005 #1 DO NOT SCALE DRAWING			
MATERIAL 4X2 AA CHANNEL 6061-T6			
FINISH AS NOTED			
TITLE AOSN BATTERY CAGE CENTER CHANNEL		DWG NO. 049-4-0200	SHEET OF
SCALE		RELEASE DATE	DF

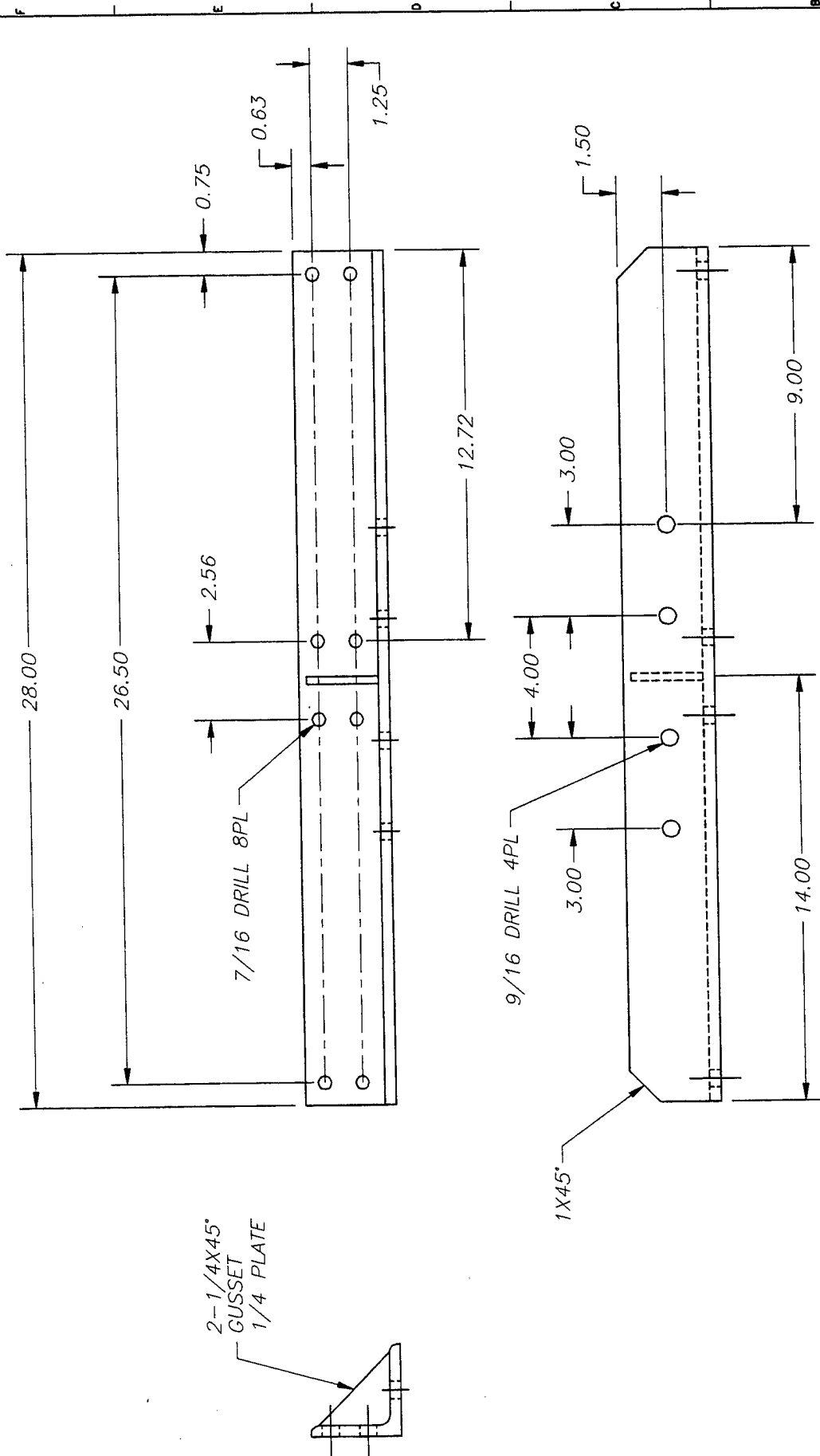

2-1/4X45°
GUSSET
1/4 PLATE

9/16 DRILL 4PL

1X45°

UNLESS OTHERWISE SPECIFIED DIMENSIONS ARE IN INCHES TOLERANCES DECIMALS ANGULAR XXX.XX ±1° DO NOT SCALE DRAWING		PROJECT NO. 155727-00	DATE 09/07/97	VIGORS HOLE OCEANOGRAPHIC INSTITUTION APPLIED OCEAN PHYSICS & ENGINEERING VIGORS HOLE, MASSACHUSETTS, 02543
MATERIAL 3X3X3/8 5086 ALUMINUM	FINISH AS NOTED	DRAWN DON PETERS	CHECK	TITLE AOSN BATTERY CAGE UPPER CROSSPIECE
		SIZE 	SCALE 	DWG NO. 049-4-0201
		SHEET 3	RELEASE DATE 	SHEET OF

NOTE:
THIS PIECE TO BE MADE
USING 5086-H111 ALUMINUM

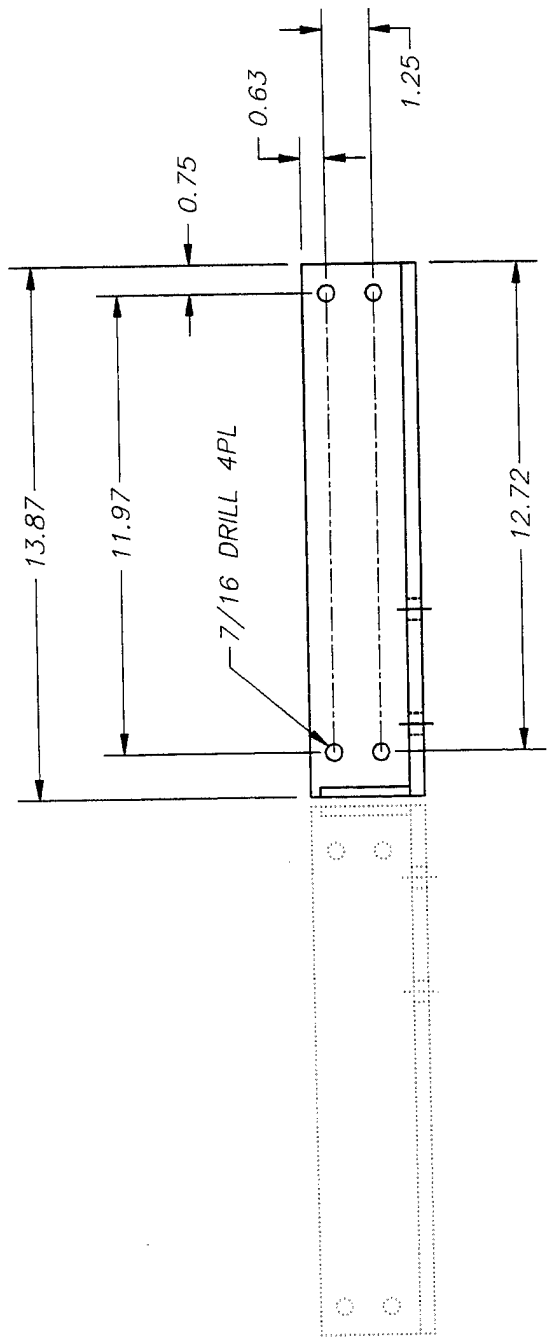

2-1/4X45°
GUSSET
1/4 PLATE

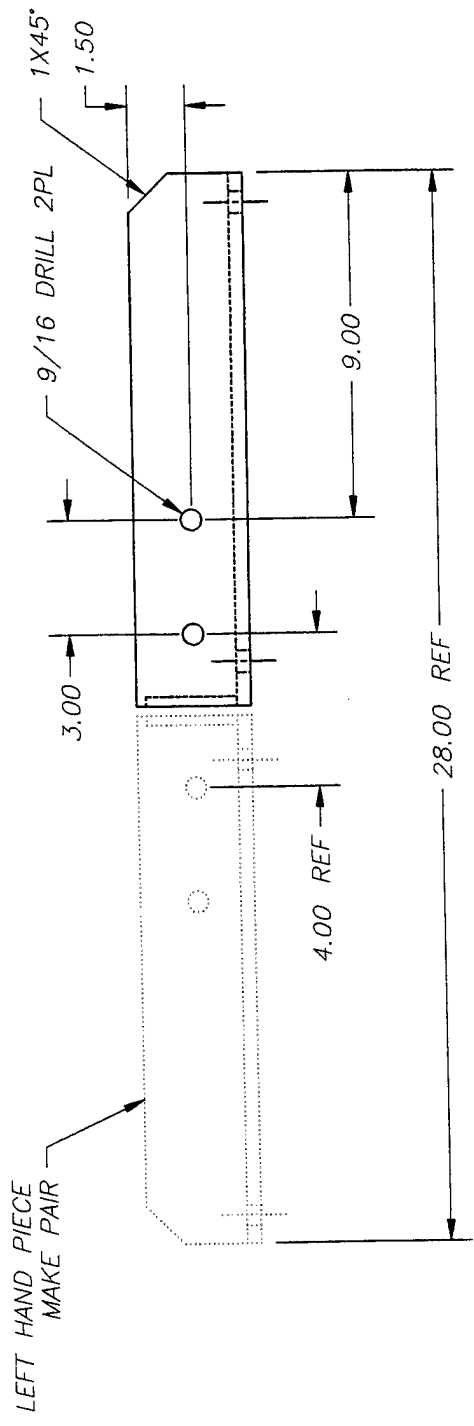
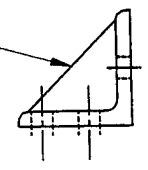

LEFT HAND PIECE
MAKE PAIR

 VIDDIS HOLE OCEANOGRAPHIC INSTITUTION APPLIED OCEAN PHYSICS & ENGINEERING VIDDIS HOLE, MASSACHUSETTS, 02543		PROJECT NO. 150188.02		TITLE AOSN BATTERY CAGE LOWER CROSSPIECE	
UNLESS OTHERWISE SPECIFIED DIMENSIONS ARE IN INCHES TOLERANCES DECIMALS ±0.1 .XX ±0.1 .XXX ±0.05 DO NOT SCALE DRAWING		DRAWN DON PETERS	DATE 09/07/97	SIZE 049-4-0202	SHEET OF
MATERIAL 3X3X3/8 ANGLE 6061-T6		CHECK (blank)		SCALE (blank)	RELEASE DATE (blank)
FINISH AS NOTED		(blank)		(blank)	

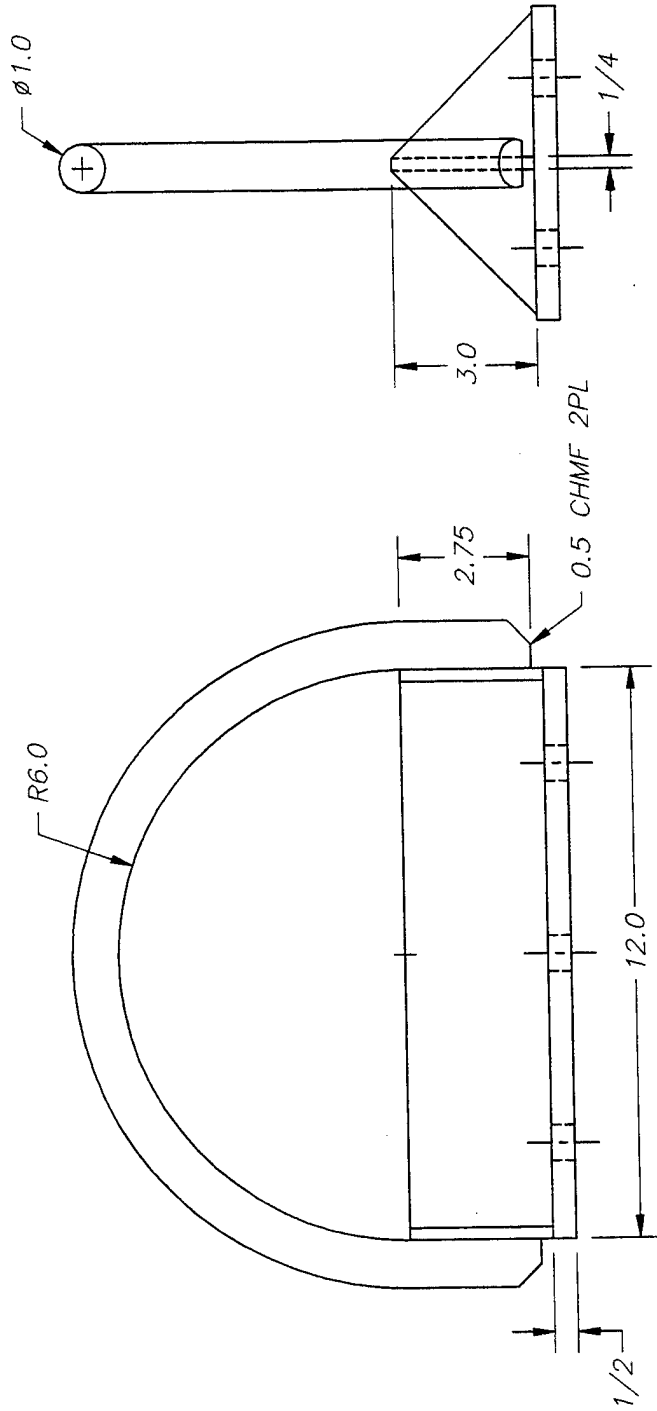
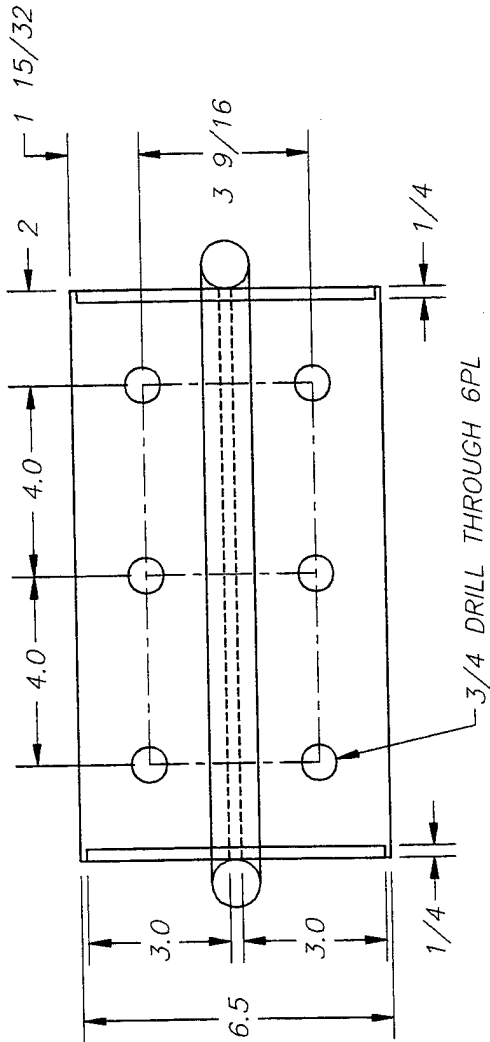

UNLESS OTHERWISE SPECIFIED DIMENSIONS ARE IN INCHES TOLERANCES DECIMALS .XXX ±0.05 .XX ±0.01 .X ±0.005 DO NOT SCALE DRAWING		PROJECT NO. DRAWN DON PETERS CHECK	DATE 9/9/97	VEDDIS HOLE OCEANOGRAPHIC INSTITUTION APPLIED OCEAN PHYSICS & ENGINEERING VEDDIS HOLE, MASSACHUSETTS, 02543
MATERIAL STAINLESS STEEL FINISH AS NOTED		TITLE AOSN LAB SEA PICKUP BALE		DWG NO. 049-4-0301
SCALE AS NOTED		RELEASE DATE		SHEET OF

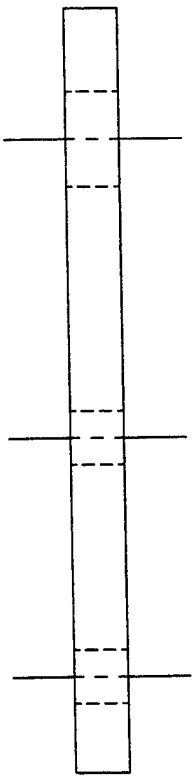

9/16 DRILL THROUGH 3 PL

1 INCH DRILL THROUGH

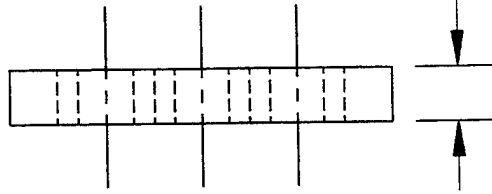
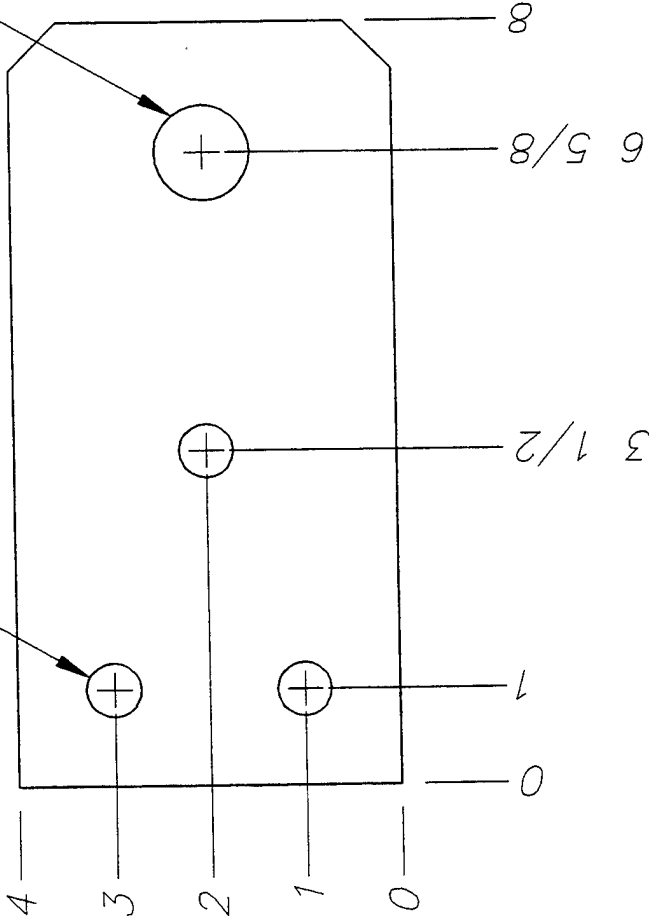

1/2

UNLESS OTHERWISE SPECIFIED DIMENSIONS ARE IN INCHES TOLERANCES DECIMALS .XX ±.01 .XXX ±.005 ANGULAR ±1° DO NOT SCALE DRAWING		PROJECT NO. DRAWN DON PETERS		DATE 9/9/97		VIDDIS HOLE OCEANOGRAPHIC INSTITUTION APPLIED OCEAN PHYSICS & ENGINEERING VIDDIS HOLE, MASSACHUSETTS, 02543	
MATERIAL STAINLESS STEEL		CHECK		TITLE AOSN BATTERY FRAME BOTTOM TANG		SIZE DWG NO. 049-4-0302	
FINISH AS NOTED		SCALE		RELEASE DATE		SHEET OF	

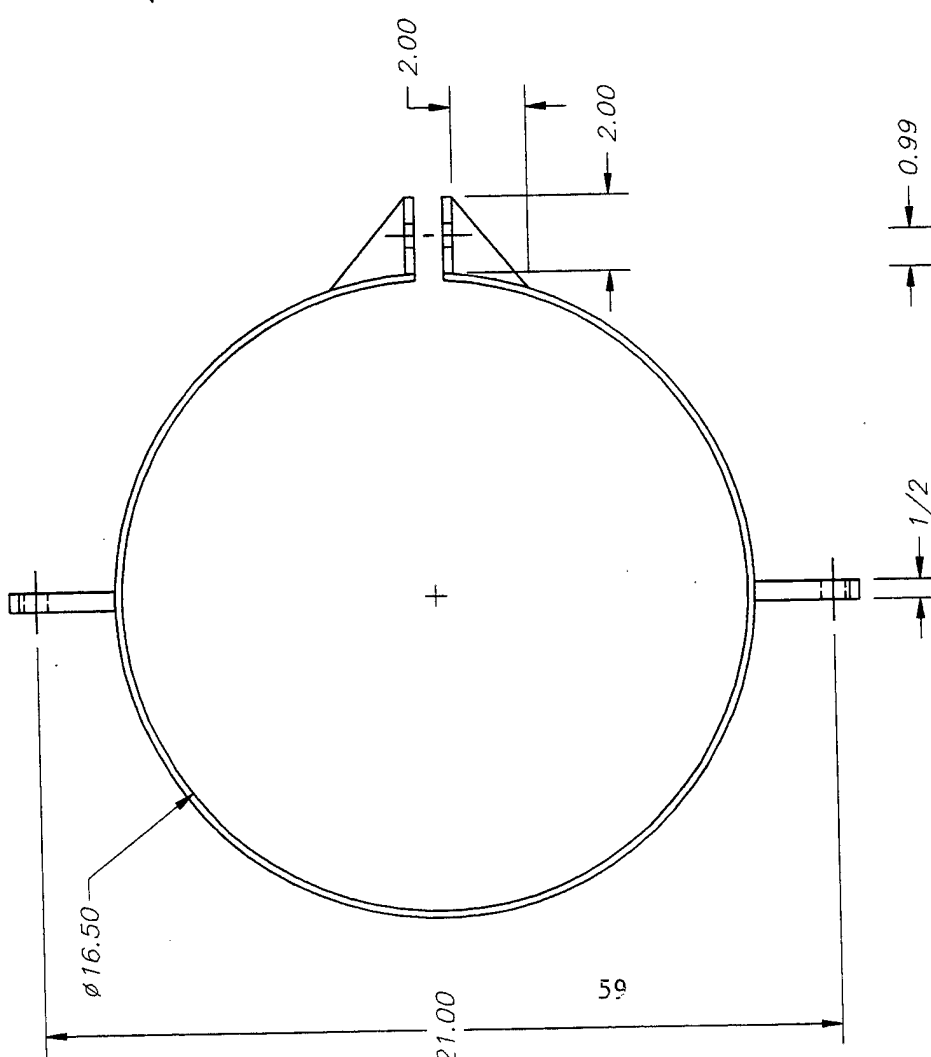
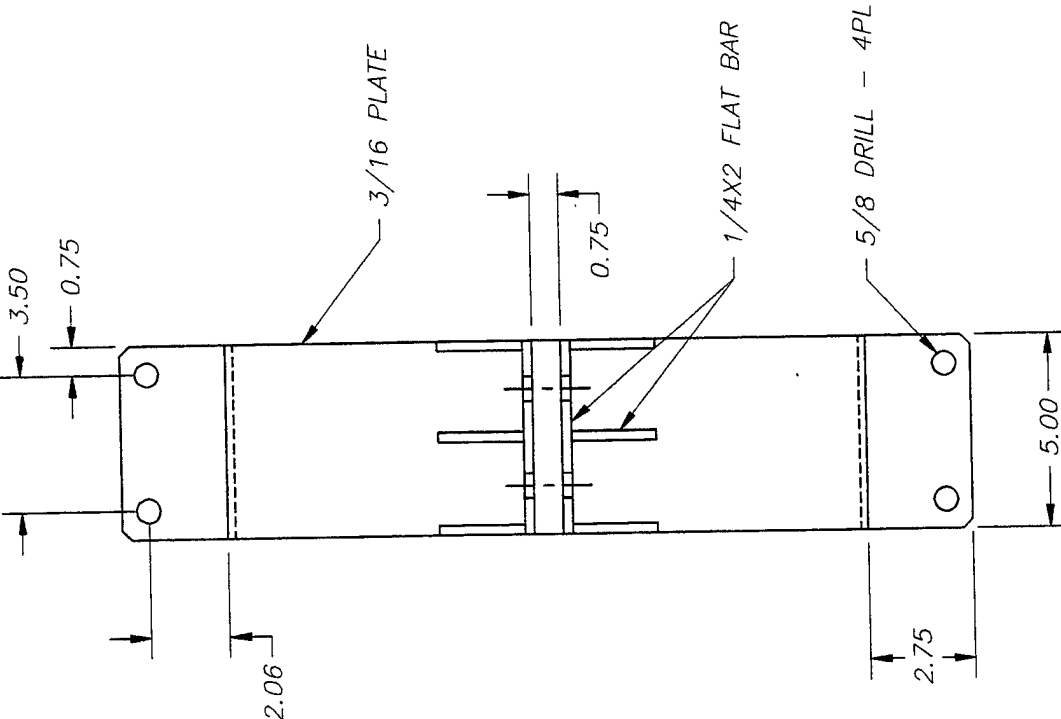

UNLESS OTHERWISE SPECIFIED DIMENSIONS ARE IN INCHES DECIMALS ANGULAR .XX ±0.1 .XXX ±0.005 DO NOT SCALE DRAWING		PROJECT NO. 156168.08	DATE 09/26/97	VOODS HOLE OCEANOGRAPHIC INSTITUTION APPLIED OCEAN PHYSICS & ENGINEERING VOODS HOLE, MASSACHUSETTS, 02543
MATERIAL 5086 ALUMINUM FINISH AS NOTED		DRAWN DON PETERS	CHECK	TITLE AOSN VEHICLE DOCK BATTERY HOUSING BAND
SIZE AS NOTED		DWG NO. 049-4-0401		SCALE AS NOTED
SHEET 1 OF 1		RELEASE DATE		DF

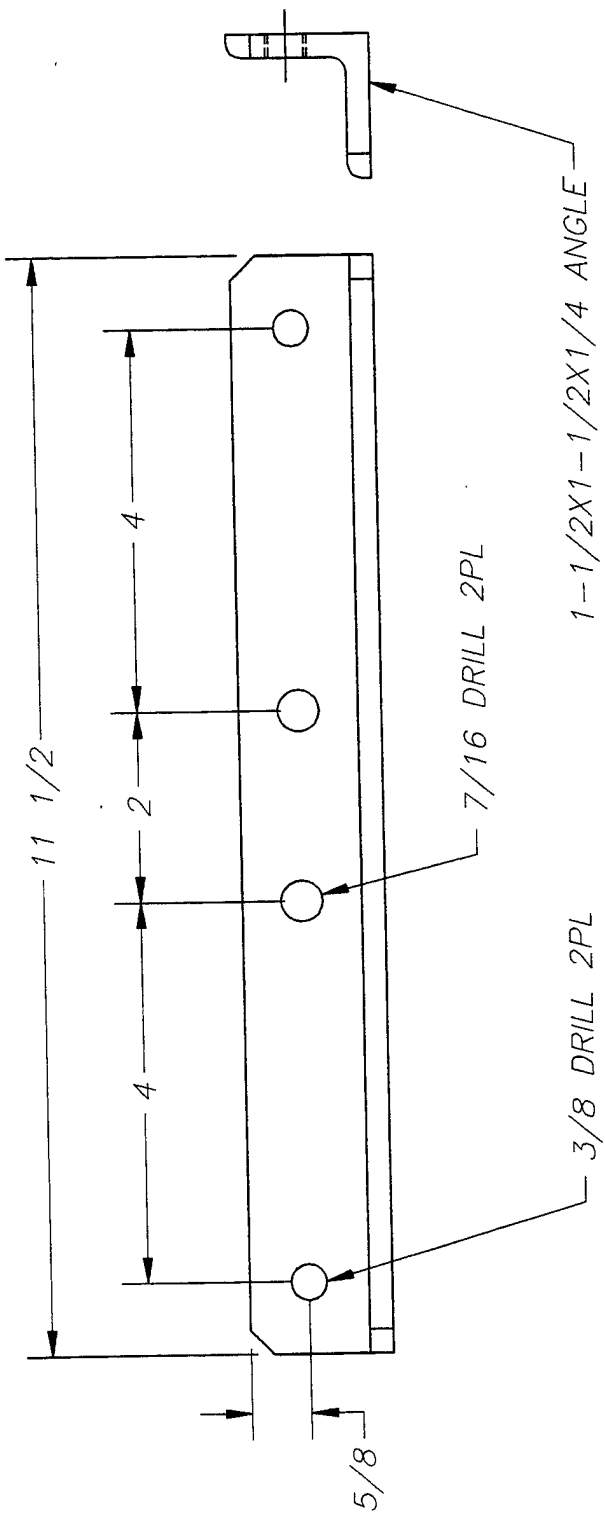

UNLESS OTHERWISE SPECIFIED DIMENSIONS ARE IN INCHES TOLERANCES DECIMALS ±0.01 ANGULAR ±1° XXX 5005 DO NOT SCALE DRAWING		PROJECT NO. 156077.00	DATE 10/08/97	APPLIED OCEAN PHYSICS & ENGINEERING VIOUDS HOLE, MASSACHUSETTS 02543
MATERIAL 6061-T6		DRAWN DON PETERS	CHECK	TITLE AOSN VEHICLE DOCK INSTRUMENT HOUSING BRACKET
FINISH AS NOTED		SIZE DWG NO. 049-4-0501		SCALE RELEASE DATE
		SHEET 2		OF

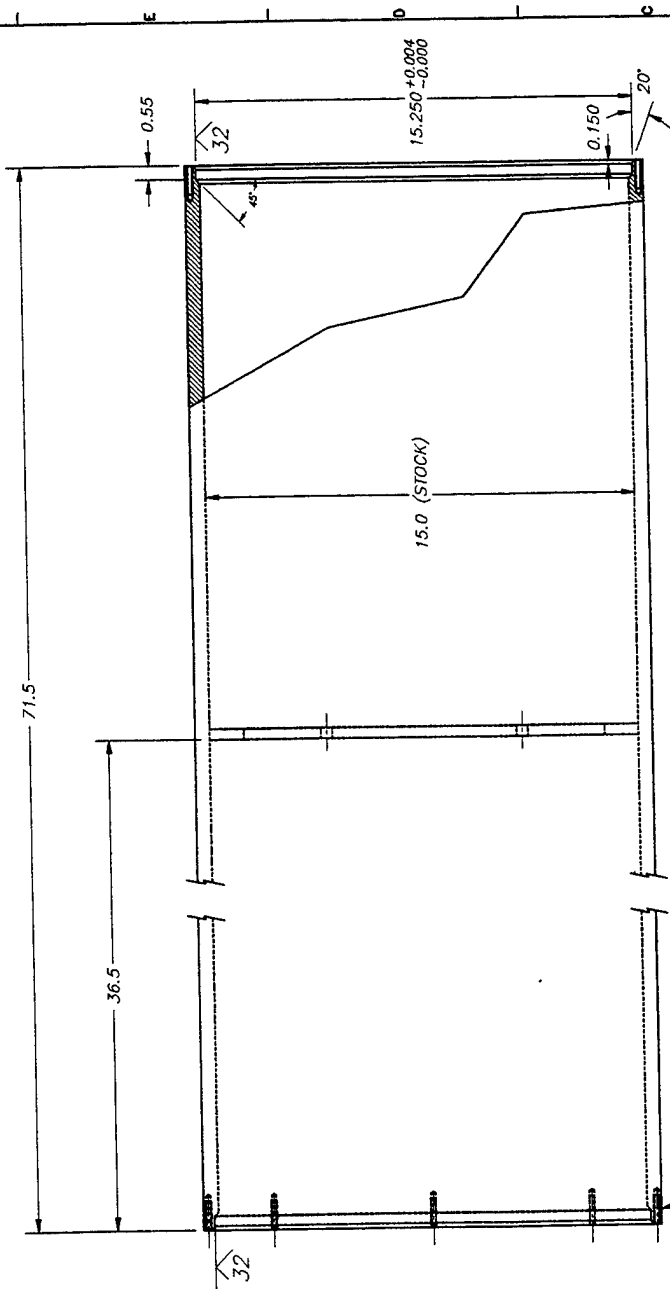

ON $\phi 15.68$ BOLT CIRCLE
 NO. 21 DRILL 1.25 DP
 10-32 TAP 1.0 DP
 8 PLACES @ 45 EACH END

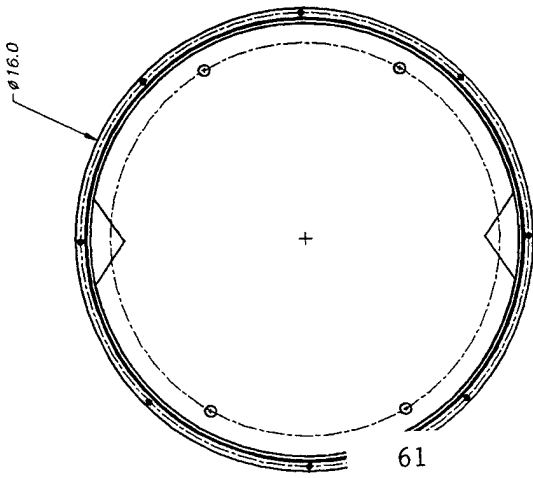

REV 09/07/97: DRAWING NUMBER

PROJECT NO. 155727.00		VOBIS HOLE OCEANOGRAPHIC INSTITUTION APPLIED OCEAN PHYSICS & ENGINEERING VOBIS HOLE, MASSACHUSETTS, 02543	
DRAWN G. McDonald	DATE 8/11/97	TITLE AOSN VEHICLE DOCK BATTERY CASE	
UNLESS OTHERWISE SPECIFIED DIMENSIONS ARE IN INCHES DECIMALS ANGULAR .XX ± 0.1 .XXX ± 0.005 DO NOT SCALE DRAWING		SIZE DWG NO.	049-5-0100
MATERIAL 6061 T-6		SCALE RELEASE DATE	SHEET OF
FINISH AS NOTED			

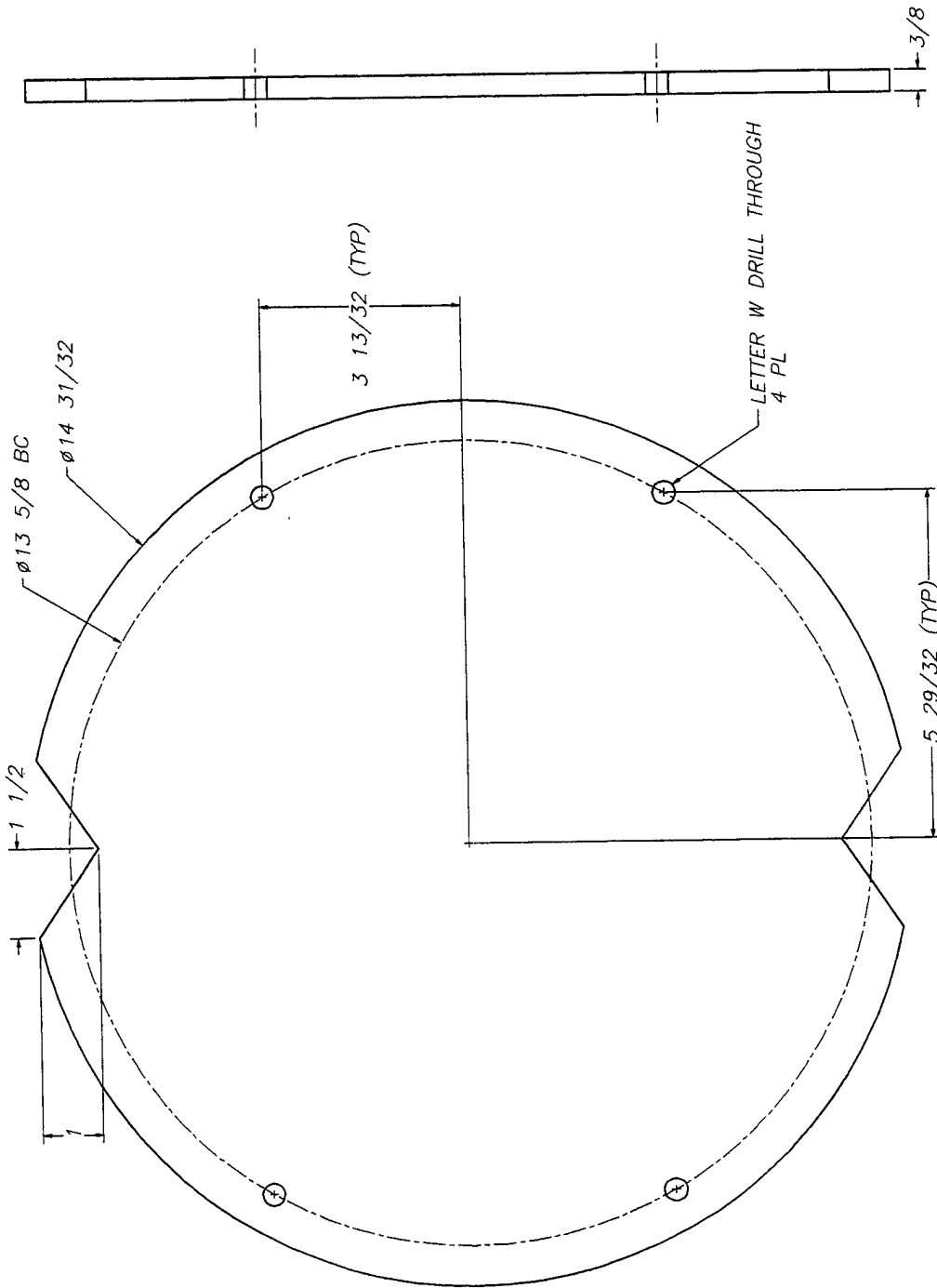

REV 09/07/97: DRAWING NUMBER

WOODS HOLE OCEANOGRAPHIC INSTITUTION
APPLIED OCEAN PHYSICS & ENGINEERING
WOODS HOLE, MASSACHUSETTS 02543

TITLE
AOSN BATTERY CASE
BULKHEAD

SIZE
DWD NO. 049-5-0101

SCALE
RELEASE DATE
SHEET 2 OF 2

PROJECT NO.
155727.00

DATE
8/21/97

DRAWN
C. McDonald

CHECK

UNLESS OTHERWISE SPECIFIED
DIMENSIONS ARE IN INCHES
DECIMALS FRACTIONS ANGLAR
3/16 1/8 1/4 3/8 1/2
3/4 7/8 1 1 1/4 1 1/2
DO NOT SCALE DRAWING

MATERIAL
6061-T6 3/8 PLATE

FINISH
AS NOTED

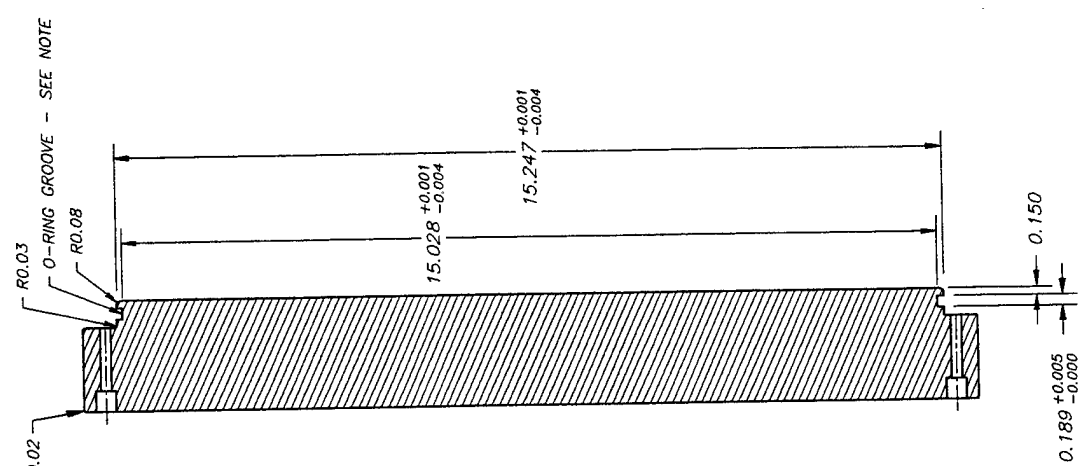

BREAK CORNERS 0.02

ON \varnothing 15.68 BOLT CIRCLE
NUMBER 6 DRILL THROUGH
1/2 CB 3/8 DP
8 PL @ 45° AS SHOWN

1 11/16 DRILL THROUGH
3/4-16 TAP 0.75 DP
1 3/8 SPOTFACE 0.03 DP

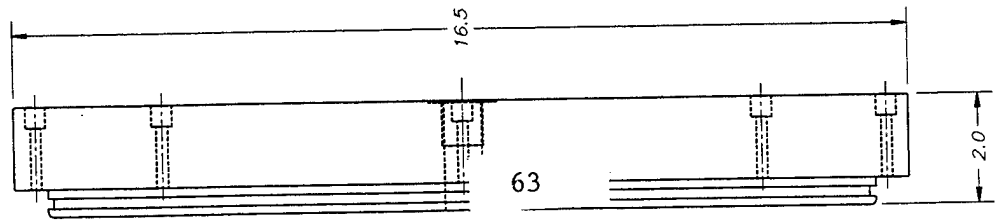
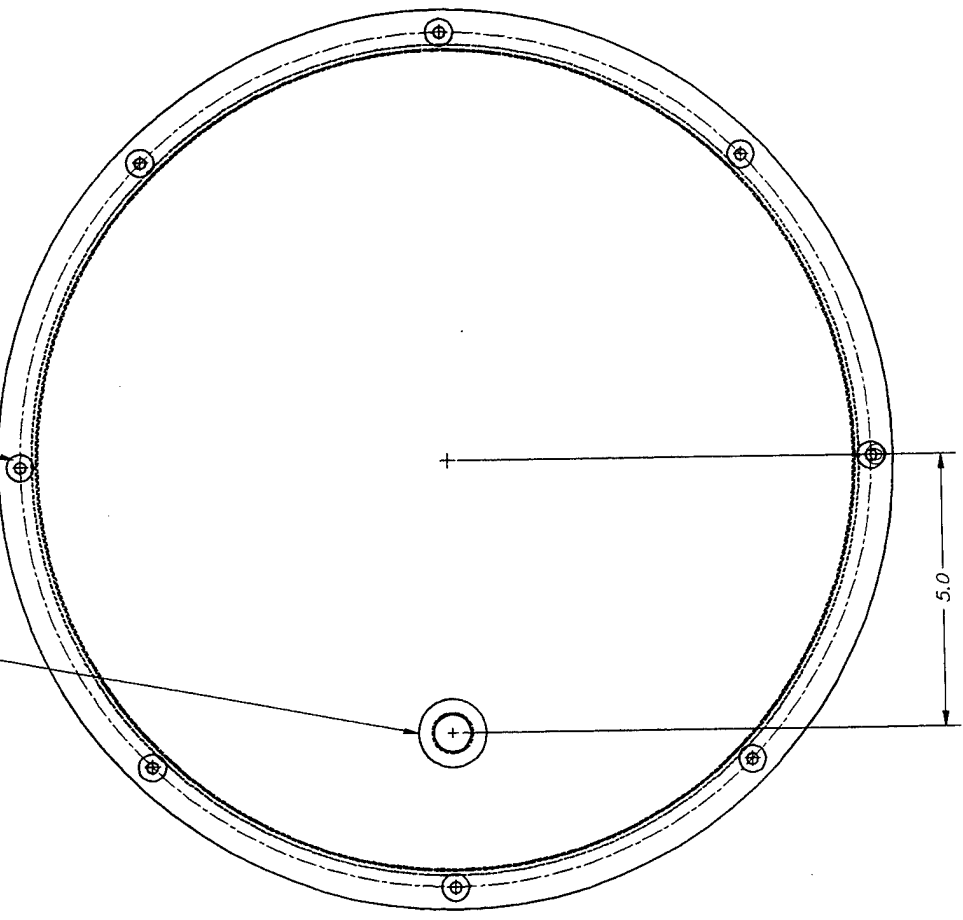

63

REV 09/07/97: DRAWING NUMBER

WOODS HOLE OCEANOGRAPHIC INSTITUTION
APPLIED OCEAN PHYSICS & ENGINEERING
WOODS HOLE, MASSACHUSETTS, 02543

TITLE
AOSN BATTERY CASE
ENDCAP

PROJECT NO.
155727.00

DRAWN
G. McDonold

DATE
8/11/97

CHECK

UNLESS OTHERWISE SPECIFIED
DIMENSIONS ARE IN INCHES
DECIMALS ANGULAR
.XX XX' XX"
XX' XX" XX' XX"
DO NOT SCALE DRAWING

MATERIAL
6061-T6 PLATE

FINISH
AS NOTED

SIZE
SCALE

RELEASE DATE

SHEET

NOTE
O-RING GROOVE FINISH .32 RMS
RADIUS INSIDE CORNERS 0.01-0.02
BREAK OUTSIDE CORNERS 0.005

049-5-0200

049-5-0200

SCALE

SCALE

SCALE

SCALE

SCALE

SCALE

SCALE

SCALE

SCALE

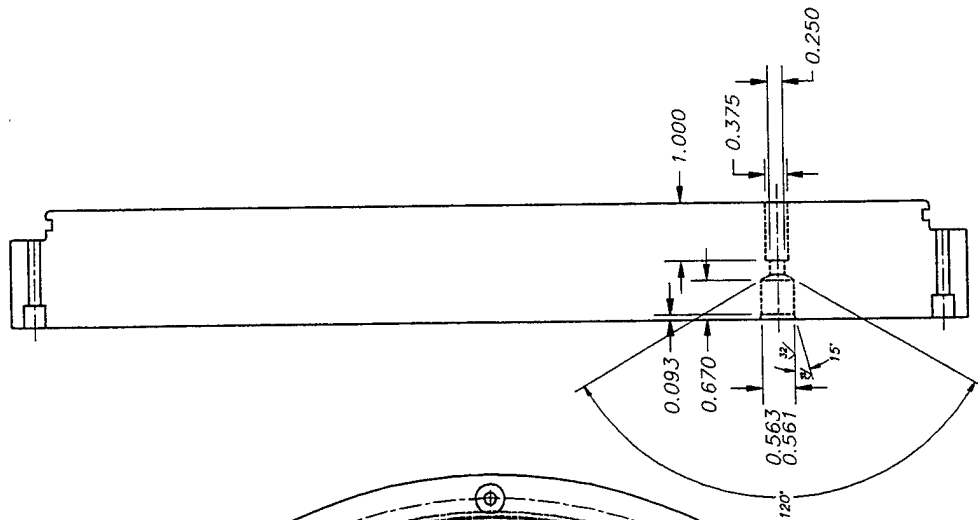
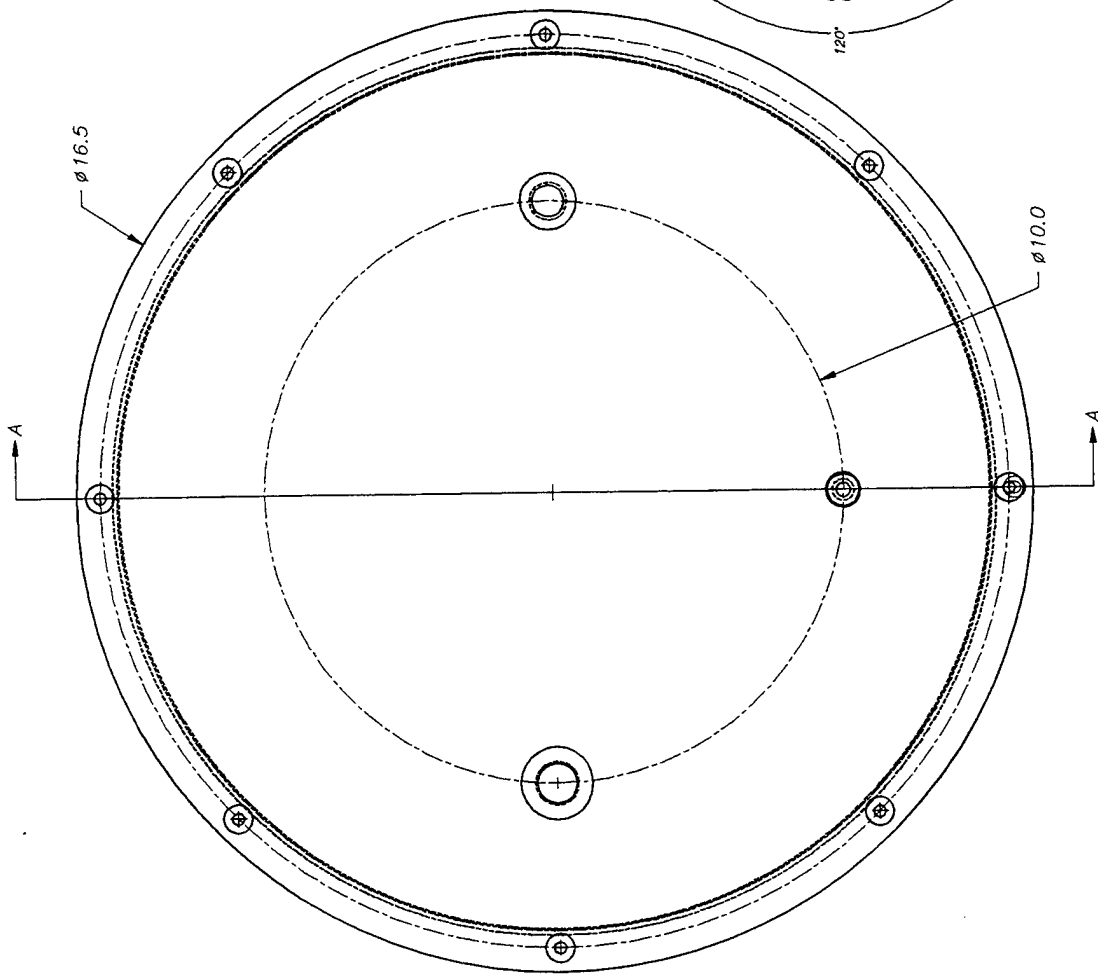

SECTION A-A

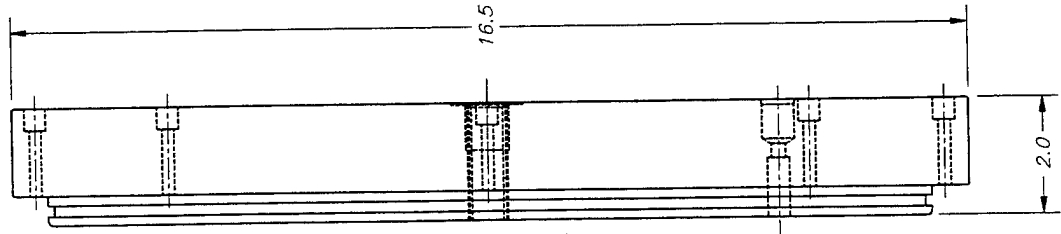

PROJECT NO. 155727.00		DATE 9/22/97		VOODS HOLE OCEANOGRAPHIC INSTITUTION APPLIED OCEAN PHYSICS & ENGINEERING VOODS HOLE, MASSACHUSETTS, 02543	
DRAWN G. McDonald		CHECK		TITLE AOSN BATTERY CASE ENDCAP PENETRATIONS	
UNLESS OTHERWISE SPECIFIED DIMENSIONS ARE IN INCHES TOLERANCES DECIMALS XX ±.005 XXX ±.002 DO NOT SCALE DRAWING		MATERIAL 6061-T6 PLATE		SIZE 049-5-0201	
FINISH AS NOTED		SCALE		RELEASE DATE	
SHEET 2 OF 2		DRAWING NO.		SHEET 2 OF 2	

NOTE
O-RING GROOVE FINISH 32 RMS
RADIUS INSIDE CORNERS 0.01-0.02
BREAK OUTSIDE CORNERS 0.005

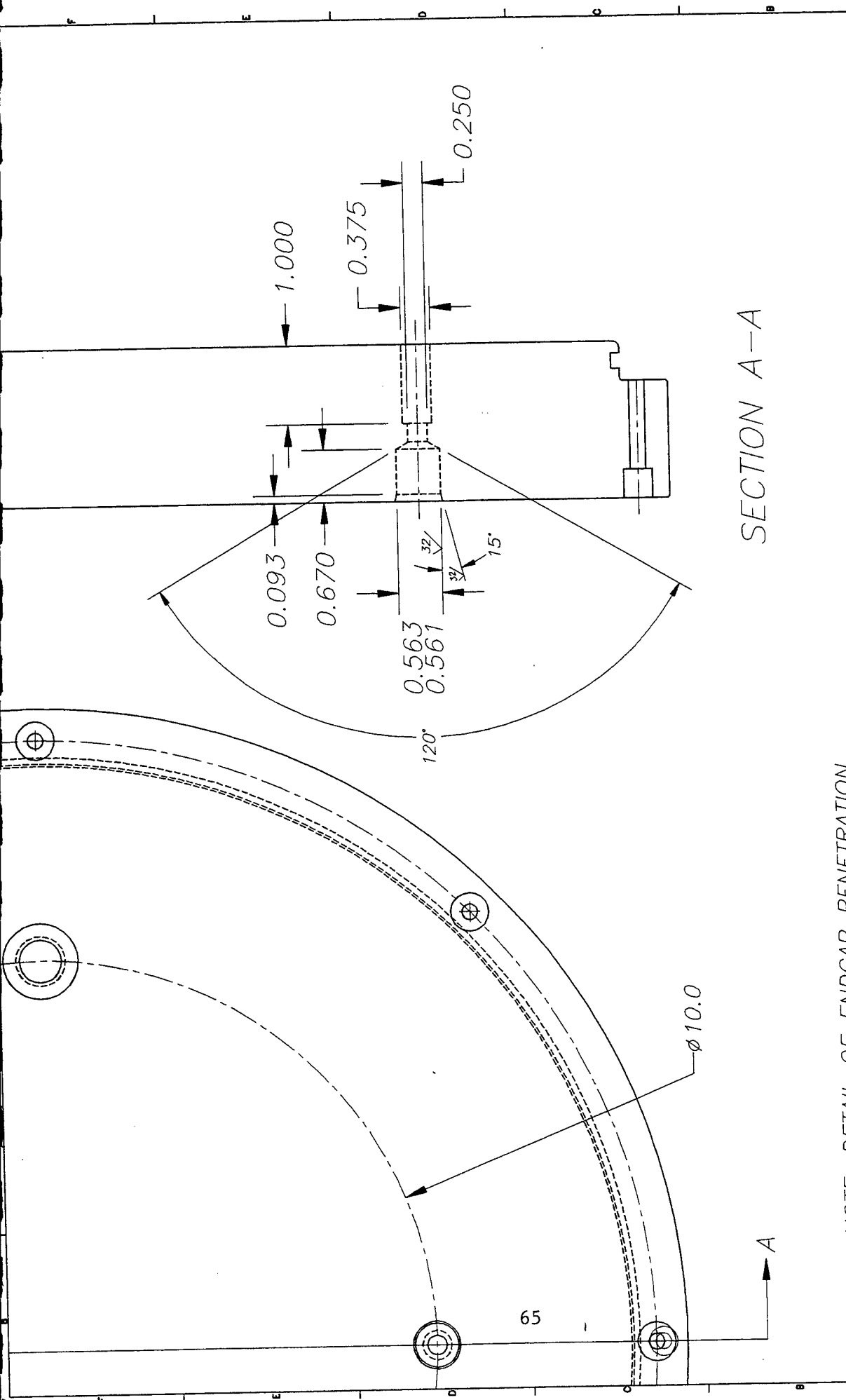

SECTION A-A

NOTE: DETAIL OF ENDCAP PENETRATION
 DWG #049-5-0201

UNLESS OTHERWISE SPECIFIED DIMENSIONS ARE IN INCHES DECIMALS .XX ±0.1 .XXX ±0.005 DO NOT SCALE DRAWING	PROJECT NO. 15527.00	DATE 9/22/97	WOODS HOLE OCEANOGRAPHIC INSTITUTION APPLIED OCEAN PHYSICS & ENGINEERING WOODS HOLE, MASSACHUSETTS 02543	
	DRAWN G. McDonald	CHECK	TITLE AOSN BATTERY CASE ENDCAP PENETRATION DETAIL	
MATERIAL 6061-T6 PLATE			SIZE	DWG NO. 049-5-0202
FINISH AS NOTED			SCALE	RELEASE DATE
				SHEET OF

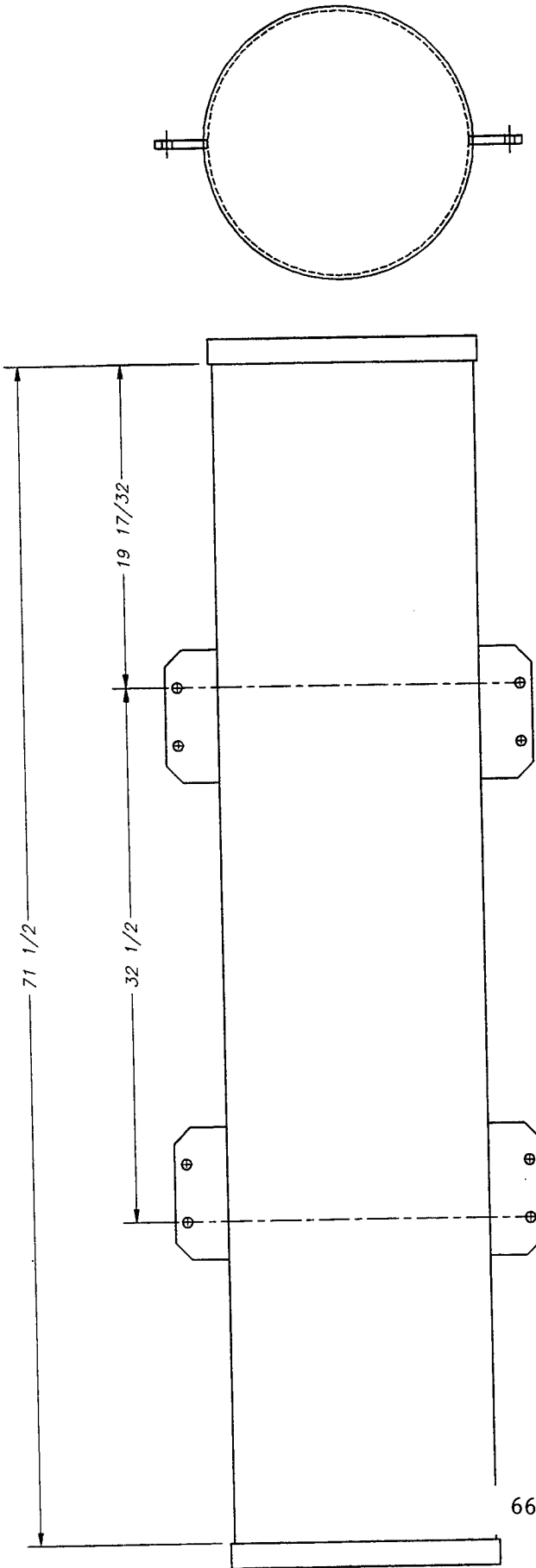

REVISED 09/11/97: MOUNT TAB LOCATION

UNLESS OTHERWISE SPECIFIED DIMENSIONS ARE IN INCHES DECIMALS .XXX ±.005 DO NOT SCALE DRAWING		PROJECT NO. DRAWN DON PETERS CHECK	DATE 9/11/97	VOODS HOLE OCEANOGRAPHIC INSTITUTION APPLIED OCEAN PHYSICS & ENGINEERING VOODS HOLE, MASSACHUSETTS, 02543
MATERIAL AS NOTED		TITLE AOSN BATTERY CASE MOUNT TAB LOCATION		DWG NO. 049-5-0300
FINISH AS NOTED		SCALE		RELEASE DATE
SHEET		SHEET		F

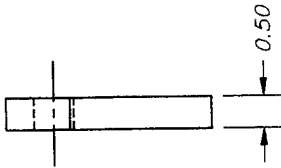
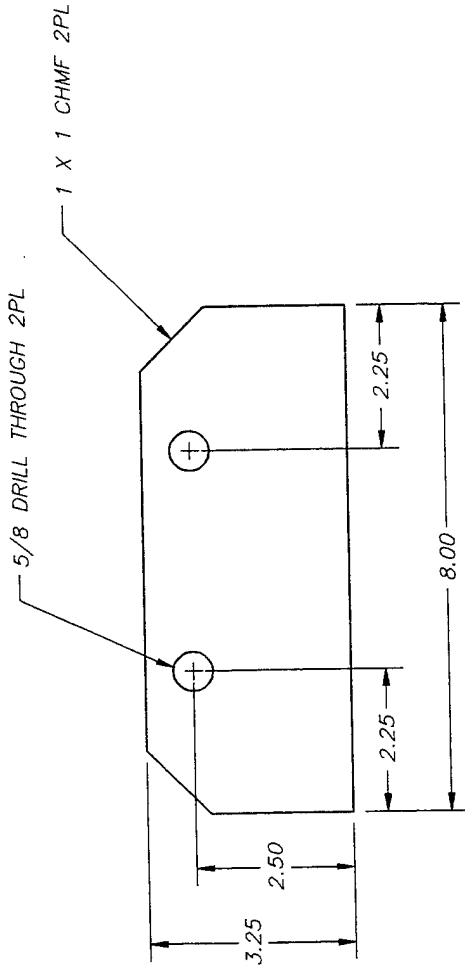

REV 09/10/97: DRAWING NUMBER

WOODS HOLE OCEANOGRAPHIC INSTITUTION
 APPLIED OCEAN PHYSICS & ENGINEERING
 WOODS HOLE, MASSACHUSETTS, 02543

TITLE
**AOSN BATTERY CASES
 MOUNTING TAB**

SIZE
 DWG NO. 049-5-0301

SCALE
 RELEASE DATE
 SHEET OF

PROJECT NO.

UNLESS OTHERWISE SPECIFIED
 DIMENSIONS ARE IN INCHES
 TOLERANCES
 DECIMALS ±0.01
 ANGULAR ±1'
 .XXX ±0.005
 DO NOT SCALE DRAWING

DATE
 9/9/97

DRAWN
 DON PETERS

CHECK

MATERIAL
 ALUMINUM 6061-T6
 FINISH
 AS NOTED

SHEET OF

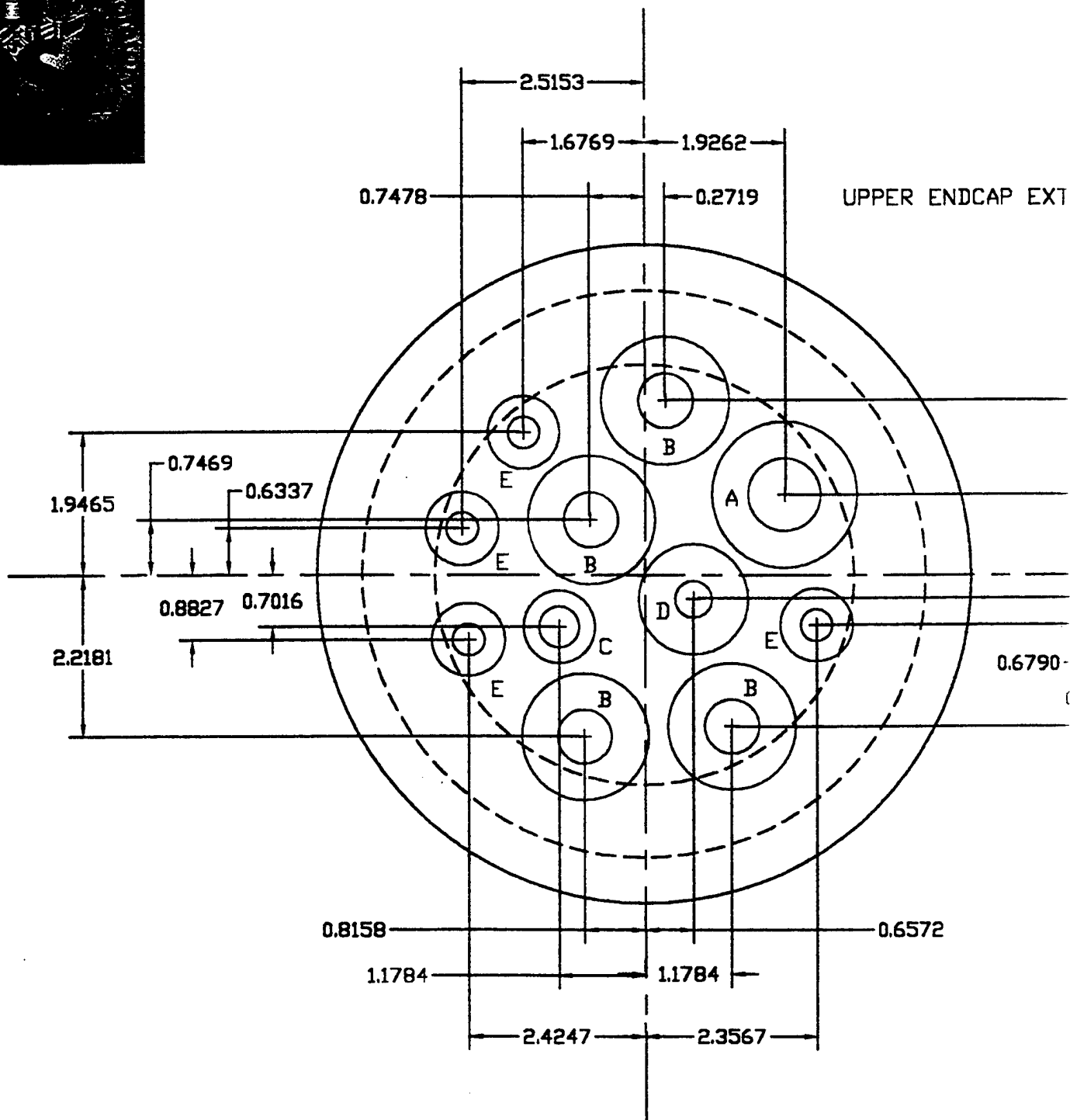
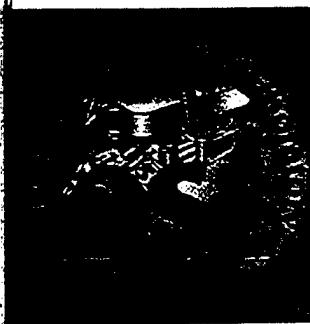

DRILL & TAP BULKHEAD THRU HOLES AS FOLLOWS:

- A = MULTI: 1-14, 2.00 FACE
- B = BATT1, BATT2, TEMP, SURF: 3/4-16, 1.75 FACE
- C = UAM: 9/16-18, 1.00 FACE
- D = EDGE: 1/2-20, 1.5 FACE
- E = ADV, EDC1, EDC2, SPARE: 7/16-20, 1.00 FACE

①

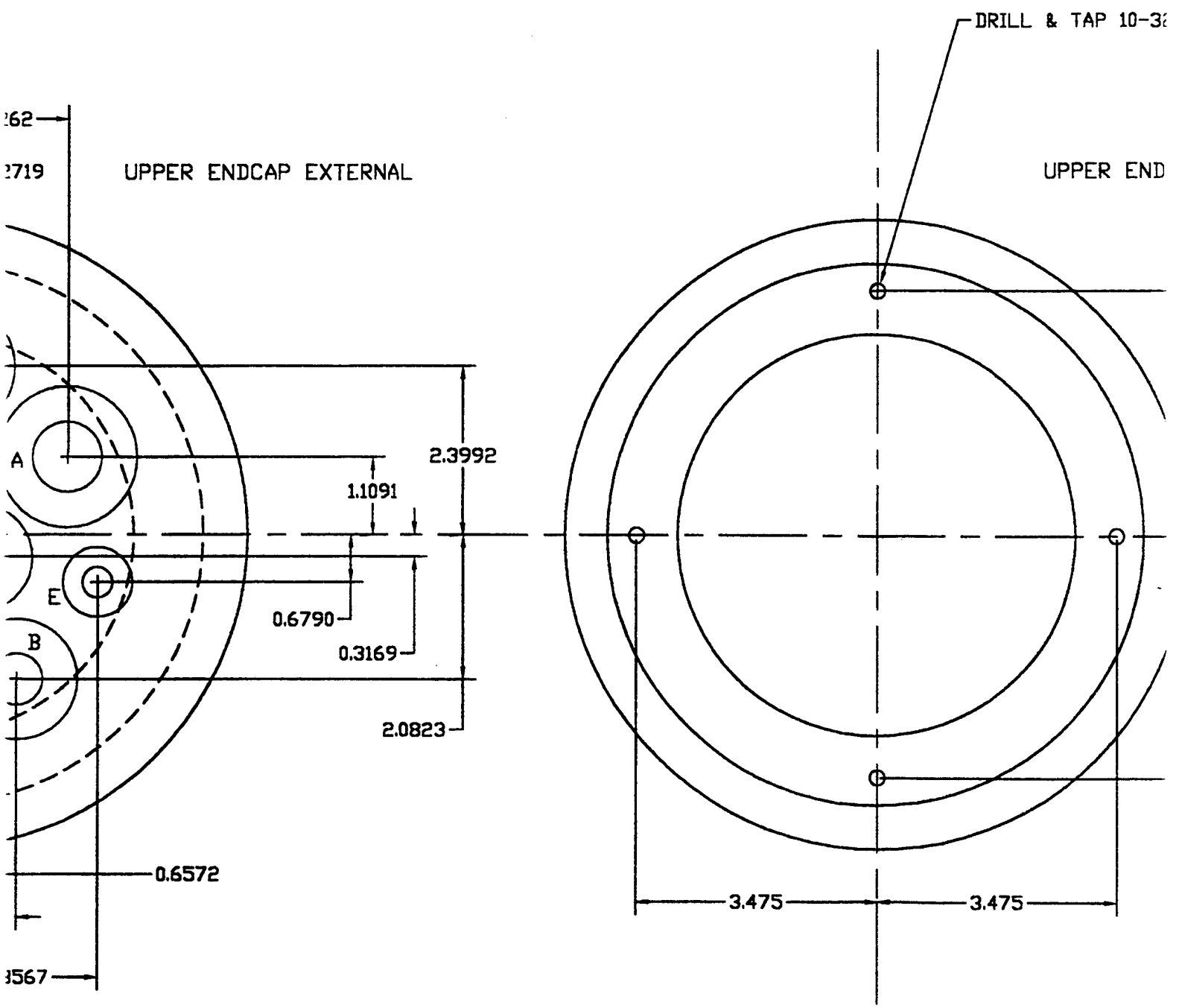

UNLESS OTHERWISE SPECIFIED DIMENSIONS ARE IN INCHES TOLERANCES: DECIMALS ANGULAR .XX ±.01 ±1' XXX ±.005 ±1' DO NOT SCALE DRAWING	PROJECT NO. 000000.00		VIEW APPLIED ✓
	DRAWN MF BOWEN	DATE 07/30/97	TITLE DC
MATERIAL AS NOTED	CHECK 68		
FINISH AS NOTED	AOP&E	MS #13	SIZE B
	BIG G-3	289-3420	SCALE NOM

2

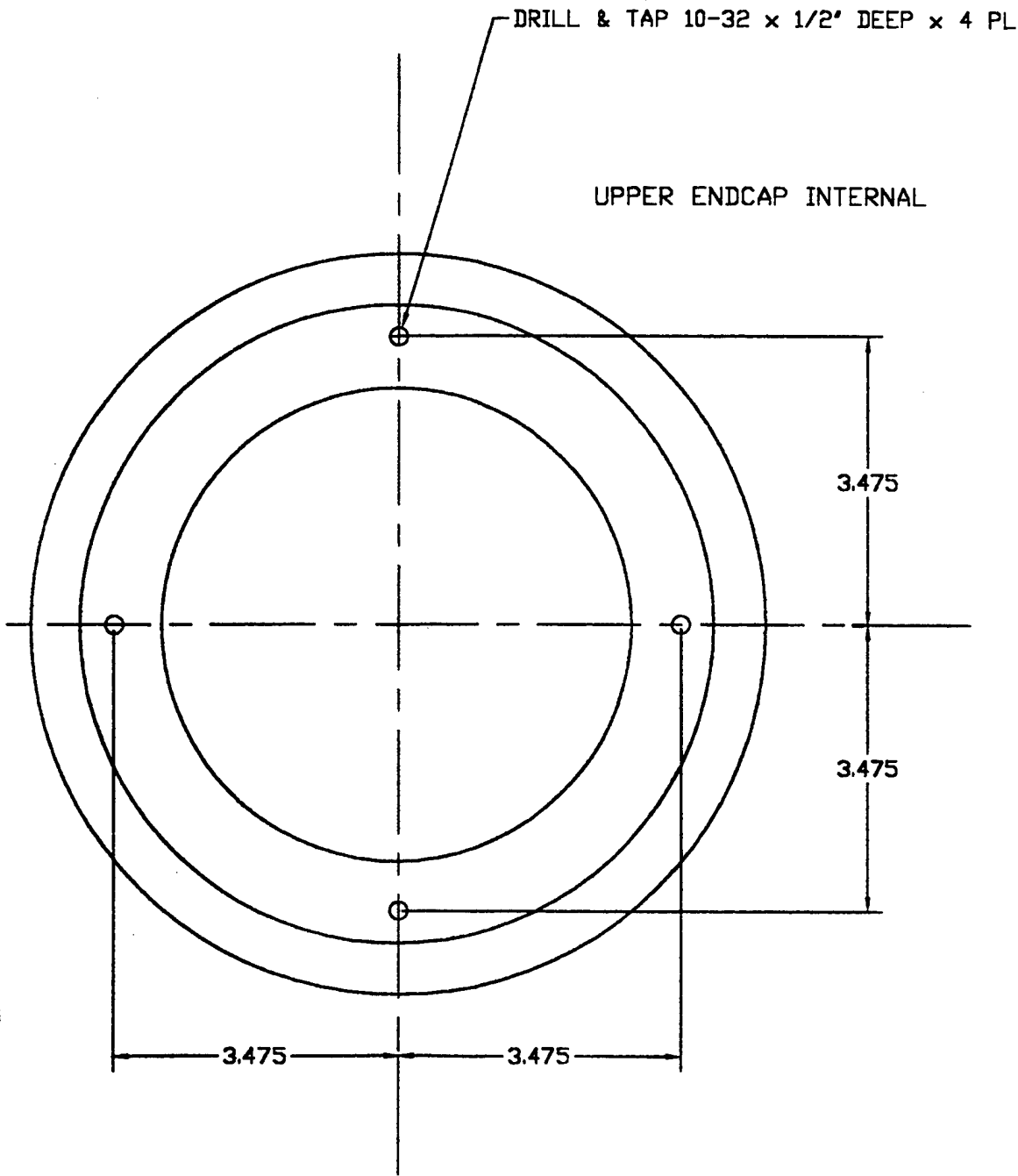

UNLESS OTHERWISE SPECIFIED DIMENSIONS ARE IN INCHES TOLERANCES DECIMALS ANGULAR XX ±.01 ±1° XXX ±.005 ±1° DO NOT SCALE DRAWING	PROJECT NO. 000000.00		WOODS HOLE OCEANOGRAPHIC INSTITUTION APPLIED OCEAN PHYSICS & ENGINEERING WOODS HOLE, MASSACHUSETTS, 02543	
	DRAWN MF BOWEN	DATE 07/30/97	TITLE DOCCON HOUSING ENDCAP FEEDTHRU DETAIL	
MATERIAL AS NOTED	CHECK 68		SIZE B	
FINISH AS NOTED	AOP&E	MS #13	DVG NO. 156-97-022	
	BIG G-3	289-3420	SCALE NONE	RELEASE DATE
			SHEET	OF

3

4.0 References

1. Bowen, M.F., A Passive Capture Latch for ODYSSEY Class AUVs, Woods Hole Oceanographic Institution, Woods Hole, MA, Blue Cover Technical Report WHOI-98-12, forthcoming, 1998.
2. Den Hartog, J.P., Advanced Strength of Materials, Dover Publications, Inc., New York, NY, pp. 90-99, 1952.
3. Dexter, S.C., Handbook Of Oceanographic Engineering Materials, Robert E. Krieger Publishing Company, Malabar, FL, 1985.
4. Impulse Enterprises, Technical Manual and Connector Selection Guide, rev 0192, San Diego, CA, 1997.
5. Parker Seal Group, O-Ring Seals Handbook, U.S. Government Manufacturing Code Identification Number 02697, Lexington, KY, 1992.
6. Pittman, Elcom, Guide to Brushless DC Motors and Planetary Gearheads, Penn Engineering and Manufacturing Corporation, Technical Bulletin 3000, Harleysville, PA, 1987.
7. Shigley, J.E., Mischke, C.R., Mechanical Engineering Design, 5th Edition, ISBN 0-07-056899-5, McGraw-Hill, Inc., New York, NY, 1989.
8. Stock Drive Products, Handbook of Shafts, Bearings and Couplings, Publication D200-4, Sterling Instrument, New York, NY, 1995.

DOCUMENT LIBRARY

Distribution List for Technical Report Exchange - July 1998

University of California, San Diego
SIO Library 0175C
9500 Gilman Drive
La Jolla, CA 92093-0175

Hancock Library of Biology & Oceanography
Alan Hancock Laboratory
University of Southern California
University Park
Los Angeles, CA 90089-0371

Gifts & Exchanges
Library
Bedford Institute of Oceanography
P.O. Box 1006
Dartmouth, NS, B2Y 4A2, CANADA

NOAA/EDIS Miami Library Center
4301 Rickenbacker Causeway
Miami, FL 33149

Research Library
U.S. Army Corps of Engineers
Waterways Experiment Station
3909 Halls Ferry Road
Vicksburg, MS 39180-6199

Marine Resources Information Center
Building E38-320
MIT
Cambridge, MA 02139

Library
Lamont-Doherty Geological Observatory
Columbia University
Palisades, NY 10964

Library
Serials Department
Oregon State University
Corvallis, OR 97331

Pell Marine Science Library
University of Rhode Island
Narragansett Bay Campus
Narragansett, RI 02882

Working Collection
Texas A&M University
Dept. of Oceanography
College Station, TX 77843

Fisheries-Oceanography Library
151 Oceanography Teaching Bldg.
University of Washington
Seattle, WA 98195

Library
R.S.M.A.S.
University of Miami
4600 Rickenbacker Causeway
Miami, FL 33149

Maury Oceanographic Library
Naval Oceanographic Office
Building 1003 South
1002 Balch Blvd.
Stennis Space Center, MS, 39522-5001

Library
Institute of Ocean Sciences
P.O. Box 6000
Sidney, B.C. V8L 4B2
CANADA

National Oceanographic Library
Southampton Oceanography Centre
European Way
Southampton SO14 3ZH
UK

The Librarian
CSIRO Marine Laboratories
G.P.O. Box 1538
Hobart, Tasmania
AUSTRALIA 7001

Library
Proudman Oceanographic Laboratory
Bidston Observatory
Birkenhead
Merseyside L43 7 RA
UNITED KINGDOM

IFREMER
Centre de Brest
Service Documentation - Publications
BP 70 29280 PLOUZANE
FRANCE

REPORT DOCUMENTATION PAGE	1. REPORT NO. WHOI-98-11	2.	3. Recipient's Accession No.
4. Title and Subtitle A Deep Sea Docking Station for ODYSSEY Class Autonomous Underwater Vehicles		5. Report Date June 10, 1998	
7. Author(s) M. F. Bowen, D. B. Peters		8. Performing Organization Rept. No. WHOI-98-11	
9. Performing Organization Name and Address Woods Hole Oceanographic Institution Woods Hole, Massachusetts 02543		10. Project/Task/Work Unit No.	
		11. Contract(C) or Grant(G) No. (C) N000-14-95-1-1316 (G)	
12. Sponsoring Organization Name and Address Office of Naval Research		13. Type of Report & Period Covered Technical Report	
		14.	
15. Supplementary Notes This report should be cited as: Woods Hole Oceanog. Inst. Tech. Rept., WHOI-98-11			
16. Abstract (Limit: 200 words) Under subcontract to the Massachusetts Institute of Technology's (MIT) Sea Grant Autonomous Ocean Sampling Network (AOSN) program, engineers and researchers at the Woods Hole Oceanographic Institution (WHOI) designed, fabricated and operated a deep sea Docking Station for ODYSSEY-class autonomous underwater vehicles (AUVs). The docking station provides shelter as well as power transfer and data exchange services for an AUV that is between autonomous midwater missions. The Station is integrated into the main tension member of a deep sea mooring system. A large subsea flotation sphere supports the mass of the Station above the seafloor. A surface expression connected by an umbilical to the Station was capable of bi-directional satellite or radio frequency communications. Primary subsystems of the Docking Station described in this report include a dock controller with multi-sensor support, long-duration battery packs, a docking pole with a moving carriage, an inductive link for power and data transfer, and information about how the Station was deployed, operated and recovered.			
17. Document Analysis a. Descriptors AUV Docking Mooring b. Identifiers/Open-Ended Terms c. COSATI Field/Group			
18. Availability Statement Approved for public release; distribution unlimited.		19. Security Class (This Report) UNCLASSIFIED	21. No. of Pages 73
		20. Security Class (This Page)	22. Price