

US ARMY
MATERIEL COMMAND

TECOM
TECHNICAL REPORT TR-RD-TE-95-16



TEST REPORT OF THE DIRECT STRIKE LIGHTNING TEST OF THE MCC-1
THERMAL PROTECTION SYSTEM (TPS) COATED ALUMINUM PANELS

Jeffery D. Craven
Electromagnetic Environmental Effects Test Branch
Electro-Mechanical Test Division
Redstone Technical Test Center

19981120 007

19 May 1995

Reproduced From
Best Available Copy



Distribution Statement: Approved for public release; distribution is unlimited.

DTIC QUALITY INSPECTED 2

DISCLAIMER

THE FINDINGS IN THIS REPORT ARE NOT TO BE CONSTRUED AS AN OFFICIAL DEPARTMENT OF THE ARMY POSITION UNLESS SO DESIGNATED BY OTHER AUTHORIZED DOCUMENTS.

TRADE NAMES

USE OF TRADE NAMES OR MANUFACTURERS IN THIS REPORT DOES NOT CONSTITUTE AN OFFICIAL ENDORSEMENT OR APPROVAL OF THE USE OF SUCH COMMERCIAL HARDWARE OR SOFTWARE.

REPORT DOCUMENTATION PAGE

Form Approved
OMB NO. 0704-0188

Public reporting burden for this collection of information is estimated to average 1 hour per response, including the time for reviewing instructions, searching existing data sources, gathering and maintaining the data needed, and completing and reviewing the collection of information. Send comments regarding this burden estimate or any other aspect of this collection of information, including suggestions for reducing this burden, to Washington Headquarters Services, Directorate for Information Operations and Reports, 1215 Jefferson Davis Highway, Suite 12C4, Arlington, VA 22202-4302, and to the Office of Management and Budget, Paperwork Reduction Project (0704-0188), Washington, DC 20503.

| | | | | |
|--|---|--|---|--|
| 1. AGENCY USE ONLY (LEAVE BLANK) | | 2. REPORT DATE | 3. REPORT TYPE AND DATES COVERED Final Technical Jan 95 | |
| 4. TITLE AND SUBTITLE Test Report of the Direct Strike Lightning Test of the MCC-1 Thermal Protection System (TPS) Coated Aluminum Panels | | | 5. FUNDING NUMBERS | |
| 6. AUTHOR(S) Jeffery D. Craven | | | | |
| 7. PERFORMING ORGANIZATION NAME(S) AND ADDRESS(ES) Director U.S. Army Redstone Technical Test Center ATTN: STERT-TE-E-EM Redstone Arsenal, AL 35898-8052 | | | 8. PERFORMING ORGANIZATION REPORT NUMBER | |
| 9. SPONSORING/MONITORING AGENCY NAME(S) AND ADDRESS(ES) | | | 10. SPONSORING/MONITORING AGENCY REPORT NUMBER | |
| 11. SUPPLEMENTARY NOTES | | | | |
| 12a. DISTRIBUTION/AVAILABILITY STATEMENT Approved for public release; distribution is unlimited. | | | 12b. DISTRIBUTION CODE | |
| 13. ABSTRACT (MAXIMUM 200 WORDS) This report details the test results of the direct strike lightning test on the MCC-1 TPS coated aluminum panels. | | | | |
| 14. SUBJECT TERMS Lightning Thermal Protection System (TPS) | | | 15. NUMBER OF PAGES | |
| | | | 16. PRICE CODE | |
| 17. SECURITY CLASSIFICATION OF REPORT UNCLASSIFIED | 18. SECURITY CLASSIFICATION OF THIS PAGE UNCLASSIFIED | 19. SECURITY CLASSIFICATION OF ABSTRACT UNCLASSIFIED | 20. LIMITATION OF ABSTRACT | |

| | |
|----------------------------|---|
| REFERENCE OR OFFICE SYMBOL | SUBJECT Initial, OPSEC, and Patent Applicability Reviews |
|----------------------------|---|

TO MEMO FOR RECORD FROM DATE CMT 1

PART I - INITIAL REVIEW
(Use Only for Unclassified Reports & Publications)

The attached information, Test Report of the Direct Strike Lightning Test of the MCC-1 TPS Coated AL Panels has been reviewed in Redstone Technical Test Center by Jeffery D. Craven and determined to be factual and unclassified.

Jeffery D. Craven 17 March 1995
DATE

PART II - OPSEC REVIEW
(Use Only for Unclassified Reports & Publications)

The attached information, TEST RPT OF THE DIRECT STRIKE LIGHTNING TEST OF THE MCC-1 TPS COATED AL PANELS has been given an OPSEC reviewed in REDSTONE TECH TEST CENTER by CARL E. ROBERTS and determined to be unclassified, nonsensitive, and suitable for public release. PANELS AL

Carl E. Roberts 7/19/95
DATE

PART III - PATENT APPLICABILITY REVIEW
(Use Only for Classified & Unclassified Reports & Publications)

The attached information, Test Report of the Direct Strike Lightning Test of the MCC-1 TPS Coated AL Panels has been reviewed for patent applicability, in Redstone Technical Test Center by Jeffery D. Craven. The information

- appears to contain no patentable material.
- appears to contain patentable material.

- patent disclosure has been submitted.
- patent disclosure should be submitted.

Jeffery D. Craven 17 March 1995
DATE

EXECUTIVE SUMMARY

This report presents the test procedures and results of the direct strike lightning effects test on the Marshall Convergent Coating -1 (MCC-1) Thermal Protection System (TPS) coated aluminum frustum and aft skirt panels.

The objective of this test effort was to subject the MCC-1 TPS coated frustum and aft skirt panels to the specified direct strike lightning current environment and then ascertain the structural effects of direct strike lightning on the frustum and aft skirt panels.

All of the panels experienced loss of MCC-1 TPS coating at the point of discharge due to the application of the high current (Component A) direct strike lightning environment. The amount of MCC-1 TPS coating loss varied from panel to panel and seemed to depend on how well the material was bonded to the aluminum panel. The application of the intermediate current (Component B) and the continuing current (Component C) direct strike lightning environments resulted in a small melted spot on the aluminum panels with no additional loss of MCC-1 TPS coating. The application of the restrike current (Component D) direct strike lightning environment resulted in slight blackening of the MCC-1 TPS coating around the area of the discharge point with, again, no additional loss of MCC-1 TPS coating.

TABLE OF CONTENTS

| | Page |
|--|------|
| I. INTRODUCTION..... | 1 |
| II. TEST OBJECTIVE..... | 1 |
| III. TEST ENVIRONMENT..... | 1 |
| IV. EVALUATION CRITERIA..... | 1 |
| V. TEST RESPONSIBILITY..... | 1 |
| VI. FACILITIES AND EQUIPMENT REQUIREMENTS..... | 3 |
| VII. TEST PROCEDURE..... | 8 |
| VIII. RESULTS..... | 17 |

APPENDICES

| | |
|--|-----|
| APPENDIX A. DIRECT STRIKE LIGHTNING EFFECTS TEST PROCEDURES FOR THE MCC-1 TPS COATED ALUMINUM PANELS | A-1 |
| APPENDIX B. PHOTOGRAPHS | B-1 |
| APPENDIX C. TEST DATA | C-1 |
| APPENDIX D. REFERENCES | D-1 |
| APPENDIX E. ABBREVIATIONS | E-1 |

LIST OF ILLUSTRATIONS

| Figure | | Page |
|--------|---|------|
| 1. | Idealized Direct Strike Lightning Waveform | 2 |
| 2. | Lightning Test Panel Configurations..... | 4 |
| 3. | Component A | 5 |
| 4. | Component B | 5 |
| 5. | Component C..... | 6 |
| 6. | Component D | 6 |
| 7. | Test Setup for the High Current and Continuing Current Lightning Tests | 9 |
| 8. | Test Setup for the High Current and Continuing Current Lightning Tests | 10 |
| 9. | Test Setup for the High Current and Continuing Current Lightning Tests | 11 |
| 10. | Test Setup for the Intermediate Current Lightning Test..... | 12 |
| 11. | Test Setup for the Intermediate Current Lightning Test..... | 13 |
| 12. | Test Setup for the Intermediate Current Lightning Test..... | 14 |
| 13. | Test Setup for the Restrike Current Lightning Test | 15 |
| 14. | Test Setup for the Restrike Current Lightning Test | 16 |

LIST OF TABLES

| Table | | Page |
|-------|---|------|
| 1. | Direct Strike Lightning Test Measurements | 19 |

I. INTRODUCTION

This report presents the test procedures and results of the direct strike lightning test conducted on the Marshall Convergent Coating -1 (MCC-1) Thermal Protection System (TPS) coated aluminum frustum and aft skirt panels. The test was conducted during January 1995 at the Hazardous Effects Lightning Simulator (HELs) Test Facility located within Test Area 5 of Redstone Arsenal. The test was conducted by personnel of the Electromagnetic Environmental Effects (E³) Test Branch, Electro-Mechanical Test Division, Redstone Technical Test Center (RTTC).

II. TEST OBJECTIVE

The objective of this test effort was to subject the MCC-1 TPS coated frustum and aft skirt panels to the specified direct strike lightning current environment and then ascertain the structural effects of direct strike lightning on the frustum and aft skirt panels. This effort did not assess the indirect effects of lightning from a direct strike, nor near strike, lightning event on the frustum or aft skirt panels.

III. TEST ENVIRONMENT

The environments required for this test effort were for Zone 1B type lightning strikes as specified in MIL-STD-1757A. Since the objective of this test effort is to determine the structural effects of direct strike lightning on the frustum and aft skirt panels, Test Method T02 of MIL-STD-1757A was utilized to test lightning current waveform Components A, B, C, and D. The requirements for these lightning current waveform components are defined in Figure 1.

IV. EVALUATION CRITERIA

As the objective of this test was data collection, there were no set pass or fail criteria.

V. TEST RESPONSIBILITY

A. REDSTONE TECHNICAL TEST CENTER

The RTTC was responsible for planning and conducting all tests, coordinating and scheduling test facilities, establishing and applying security and safety procedures, providing system instrumentation and test fixtures, modifying test hardware as required, collecting and analyzing test data, and providing a final report or report letter.

B. UNITED TECHNOLOGIES CORPORATION/UNITED STATES BOOSTER INCORPORATED

United Technologies Corporation/United States Booster Incorporated (UTC/USBI) was responsible for providing overall coordination of the test program, including, but not limited to, supplying technical assistance, identifying and providing all test hardware, and support hardware, and for the evaluation of the frustum and aft skirt panels with respect to space shuttle flight safety and crew hazard.

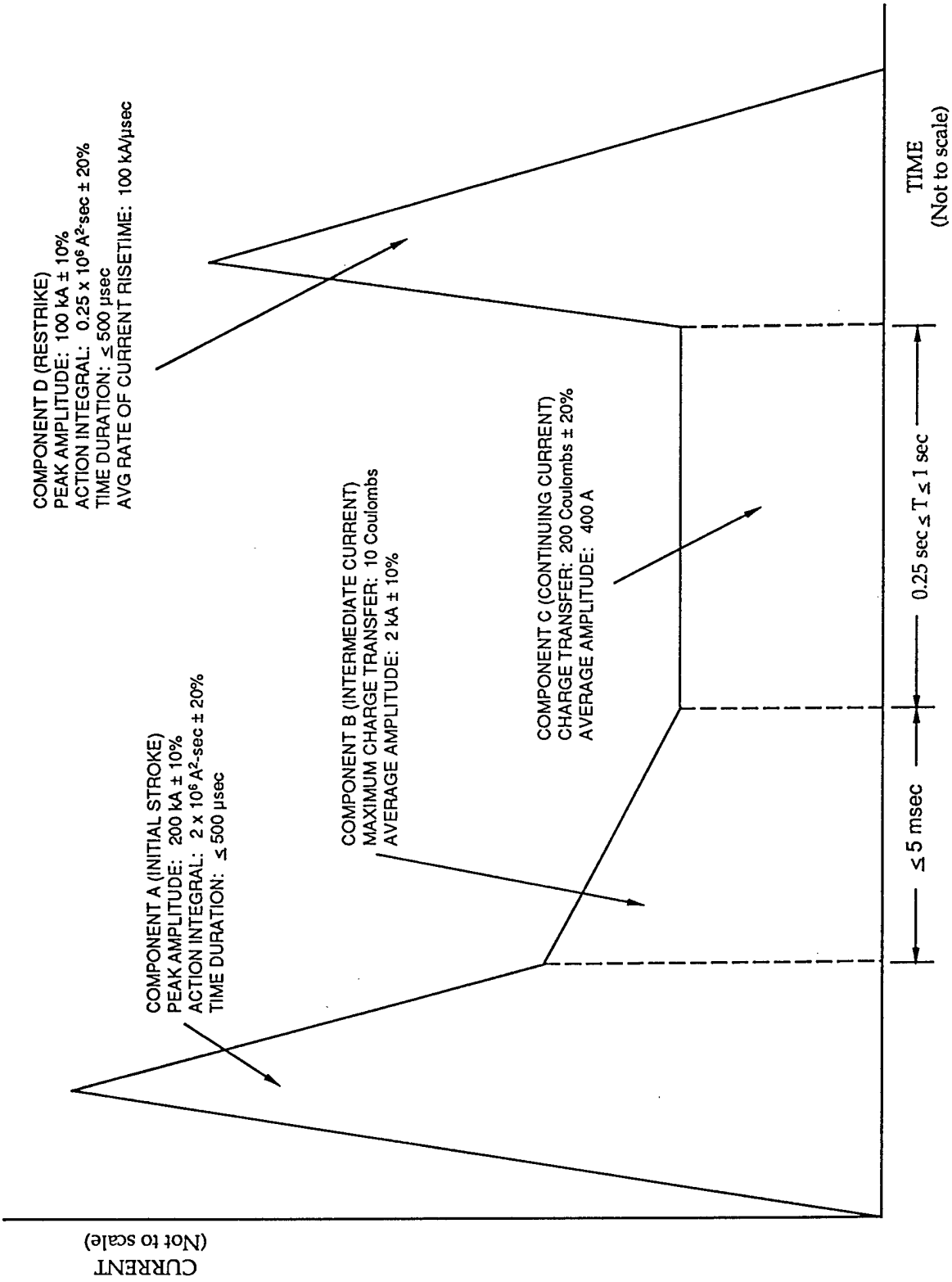

Figure 1. Idealized Direct Strike Lightning Waveform.

C. GEORGE C. MARSHALL SPACE FLIGHT CENTER

George C. Marshall Space Flight Center (MSFC), National Aeronautics and Space Administration (NASA), was responsible for providing the funds for this test program.

VI. FACILITIES AND EQUIPMENT REQUIREMENTS

This section describes the test hardware, facility, and instrumentation utilized to conduct the direct effects lightning test of the MCC-1 TPS coated aluminum frustum and aft skirt panels.

A. TEST HARDWARE

The test hardware was provided by UTC/USBI and consisted of six frustum panels and six aft skirt panels coated with MCC-1 TPS (Figure 2). Three of the frustum panels, as well as three of the aft skirt panels, were provided for calibration purposes.

B. FACILITY

This section describes the various components comprising the simulated direct strike lightning equipment of the Hazardous Lightning (HELs) Test Facility.

1. HIGH CURRENT CAPACITOR BANK

The high current (Component A) capacitor bank consists of 480 capacitors, each rated at 60 kV and 1.875 mF, configured as a two-stage Marx bank with a total capacitance of 56.25 mF and an output voltage of 220 kV. A 2.25 μ F, 300 kV peaking capacitor circuit is utilized in conjunction with the high current capacitor bank to increase the current rate-of-rise time to 6.5 msec. The high current capacitor bank can generate a 200 kA \pm 10% peak current simulated Component A direct strike lightning waveform with an action integral of 2.0×10^6 A²sec \pm 20% (Figure 3).

2. INTERMEDIATE CURRENT CAPACITOR BANK

The Intermediate Current (Component B) Capacitor Bank consists of 5 layers of electrolytic capacitors connected in series. Each layer contains 8, 450 volt, 3000 μ F capacitors in parallel. The total calculated capacitance is 4800 μ F. The charge voltage is 2100 V. The intermediate current capacitor bank can generate a 2000 A 10% simulated direct strike Component B waveform with a peak current of approximately 5800 A and 10 Coulombs (C) of charge transfer (Figure 4).

3. CONTINUING CURRENT CAPACITOR BANK

The Continuing Current (Component C) Capacitor Bank consists of two layers of electrolytic capacitors connected in series. Each layer contains 196, 450 volt, 3000 μ F capacitors in parallel. The total measured capacitance is 0.37 F when charged to a nominal value of 750 V. The continuing current capacitor bank can generate a simulated Component C waveform with 200 C \pm 20% of charge transfer (Figure 5).

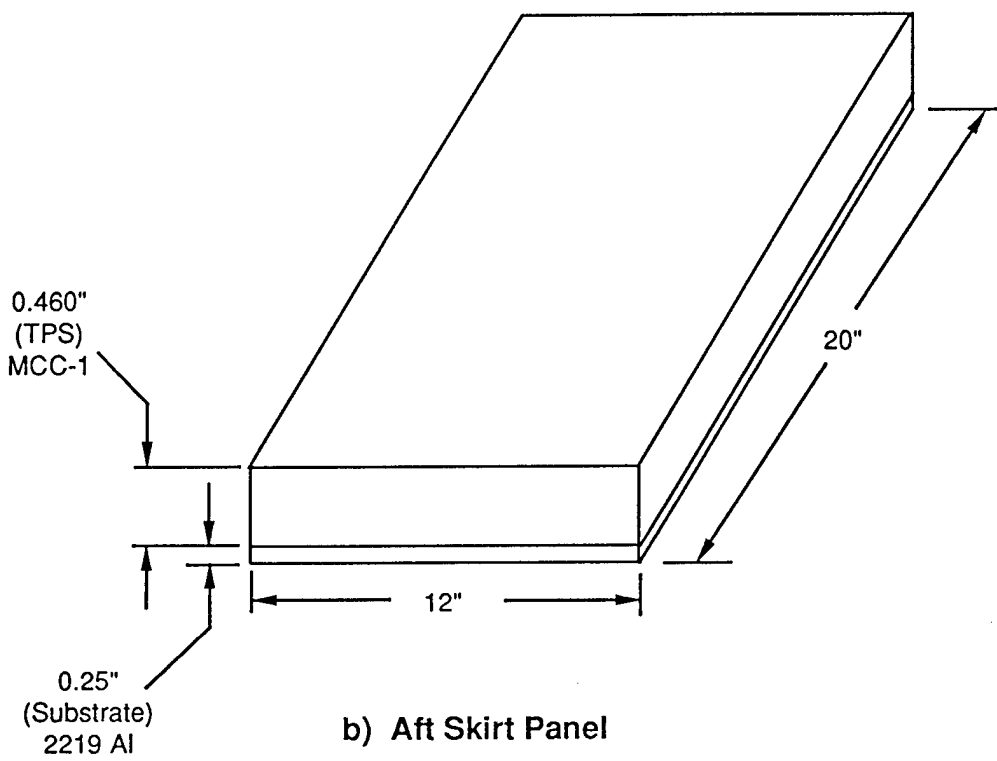
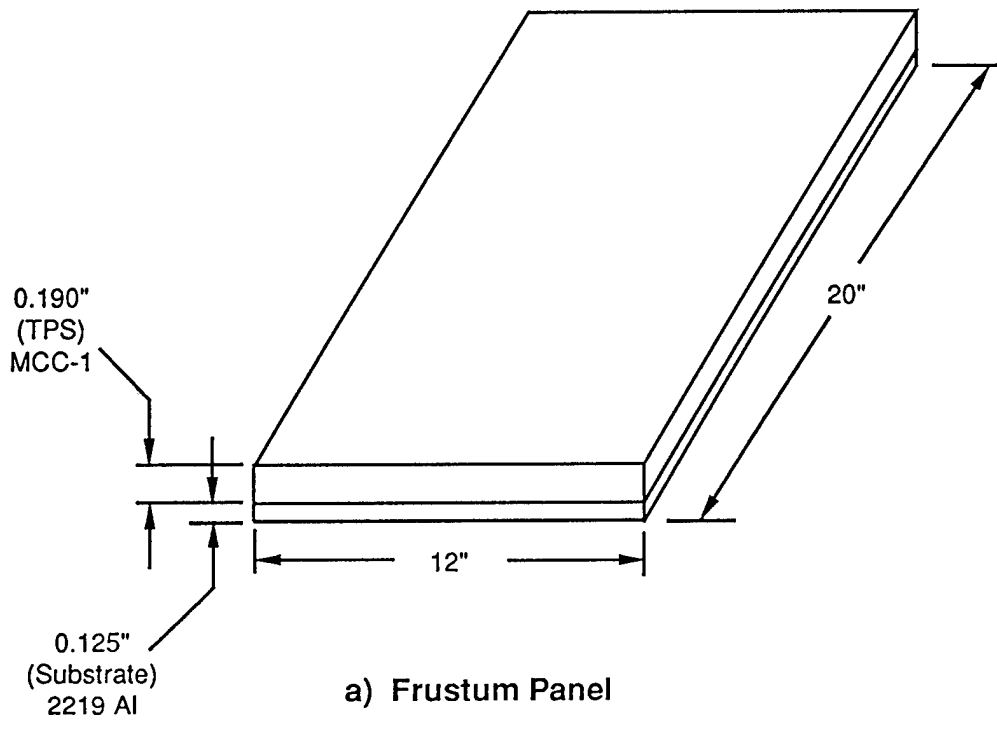

Figure 2. Lightning Test Panel Configurations

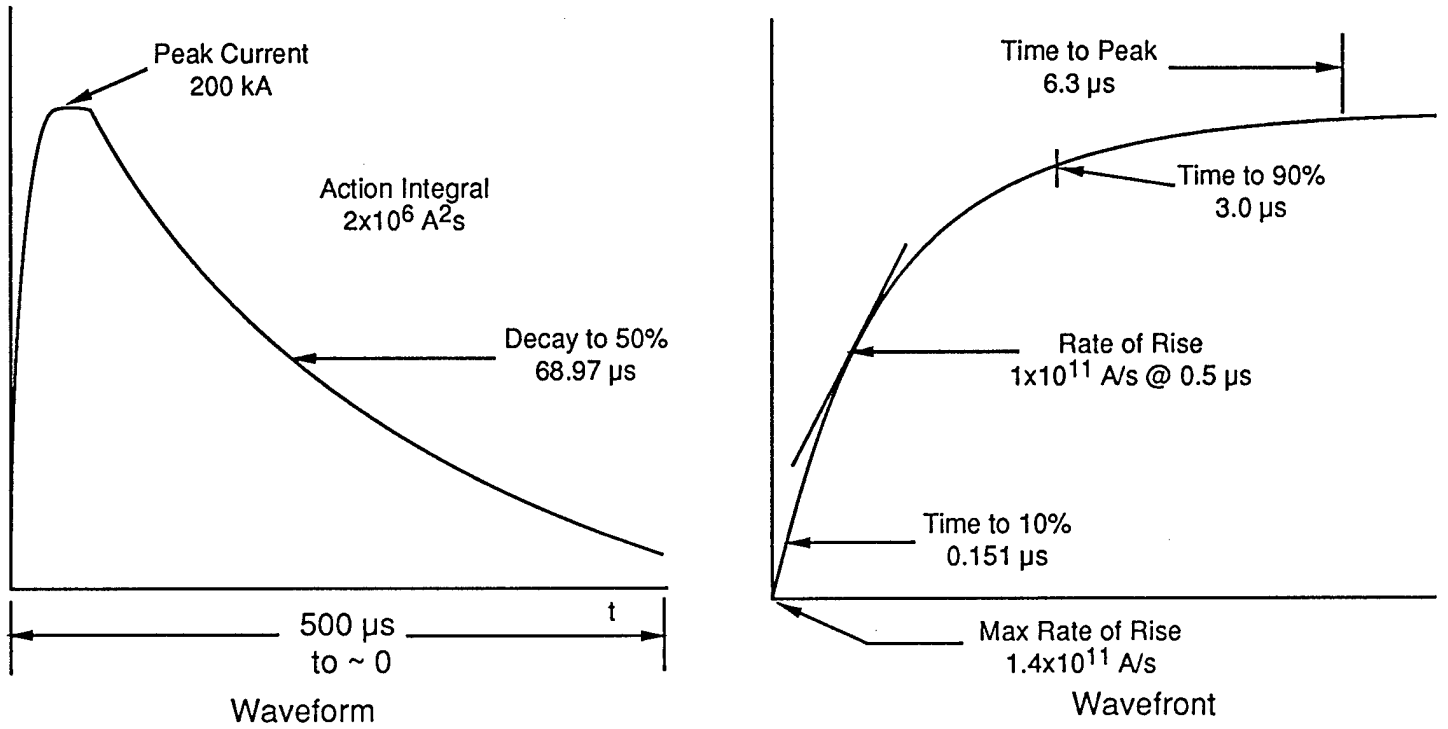

Figure 3. Component A

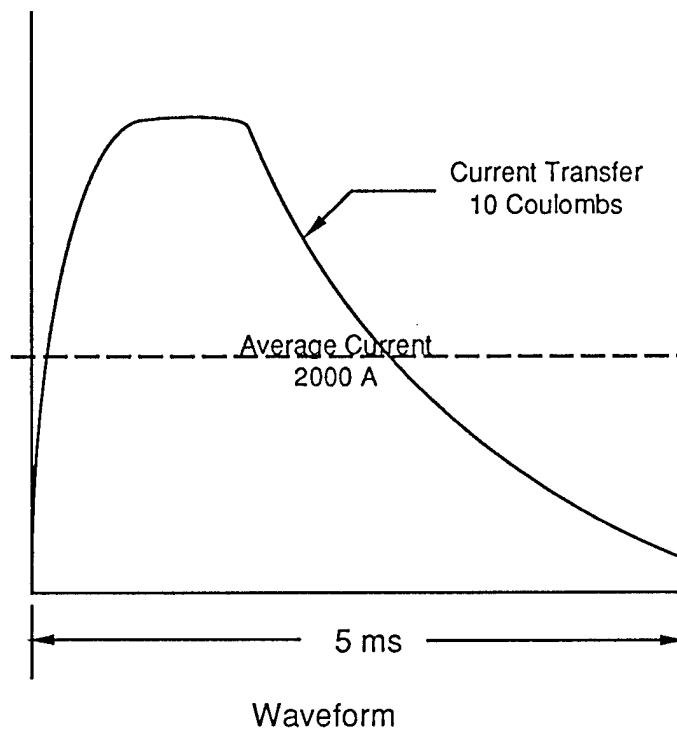

Figure 4. Component B

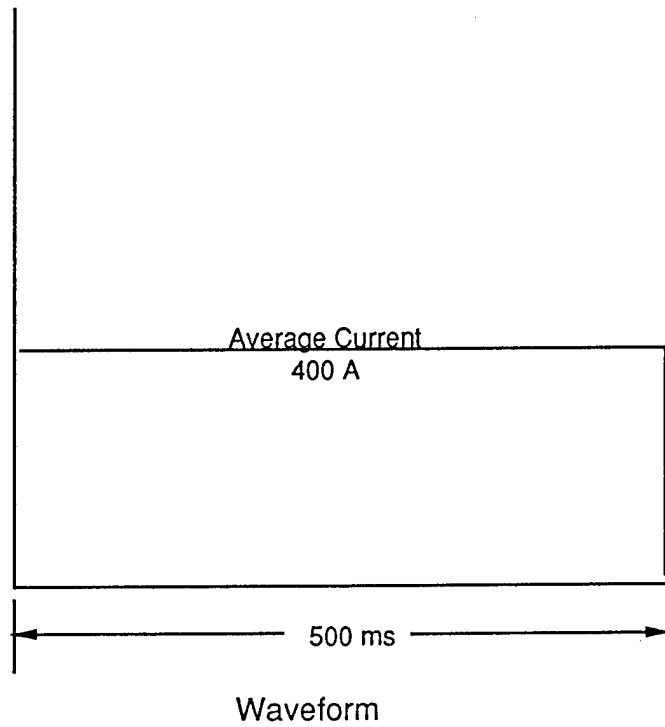

Figure 5. Component C

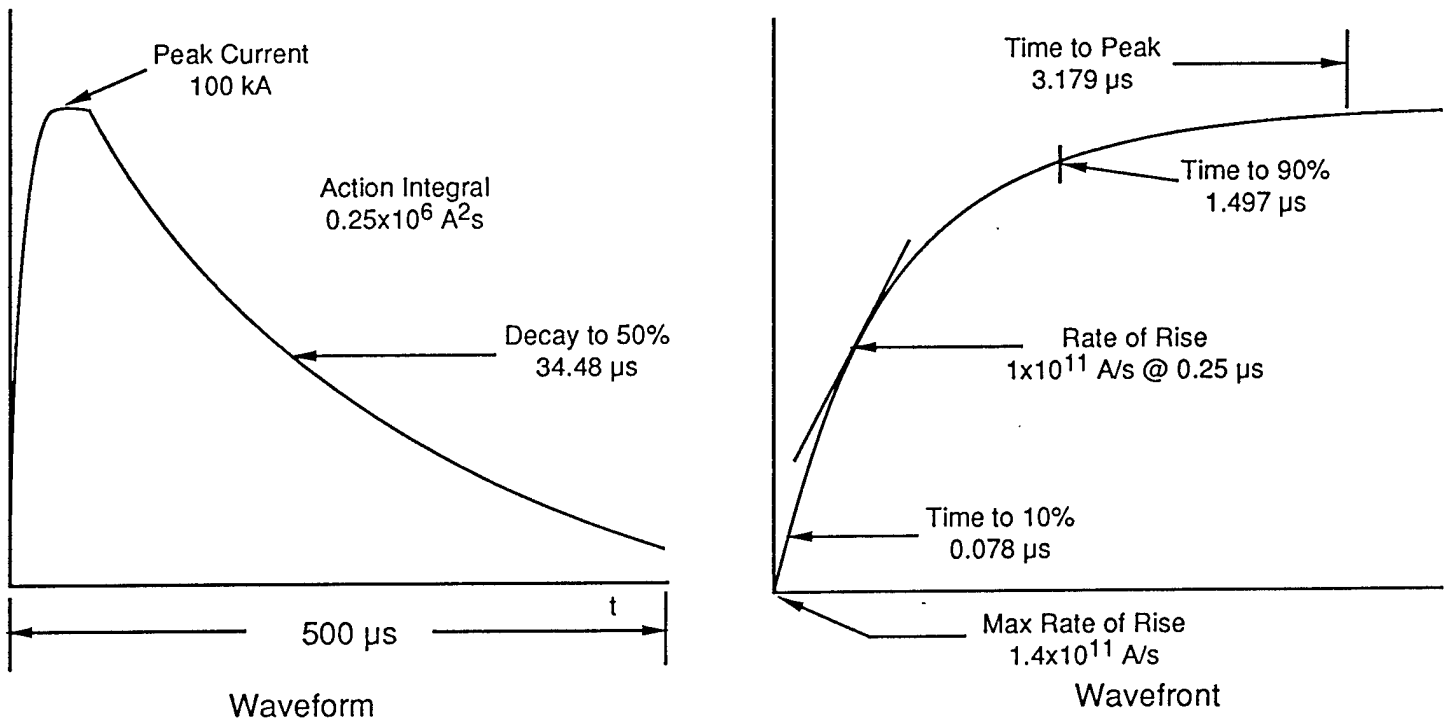

Figure 6. Component D

4. HIGH VOLTAGE RESTRIKE MARX CAPACITOR BANK

The High Voltage Restrike Marx (Component D) Capacitor Bank is an 18 stage Marx bank with a total capacitance of $0.9375 \mu\text{F}$. Each stage, consisting of nine 60 kV, $1.875 \mu\text{F}$ capacitors in parallel, is normally charged to 42 kV to provide a total output voltage of 756 kV. Energy from the Marx bank is delivered to the peaking capacitor/spark gap assembly via an one-inch insulated conductor. The peaking capacitor bank has a total capacitance of $0.027 \mu\text{F}$ and a maximum voltage capability of 2.2 megavolts. The peaking capacitor bank consists of two parallel stacks of Maxwell capacitors. Each stack contains twenty-two 0.3 mF, 100 kV capacitors in series. The high voltage restrike Marx capacitor bank can generate a $100 \text{ kA} \pm 10\%$ peak current simulated Component D waveform with an average current rate-of-rise of $1.0 \times 10^{11} \text{ A/sec}$ and a maximum current rate-of-rise of $1.4 \times 10^{11} \text{ A/sec} \pm 20\%$ (Figure 6).

C. TEST INSTRUMENTATION

The objective of the test effort was to subject the frustum and aft skirt panels to a simulated direct strike lightning test to determine the direct effects only; therefore, only the injection current waveforms are necessary to monitor to insure compliance with the simulated direct strike lightning environment criteria. Instrumentation of the frustum or aft skirt panels were not necessary.

1. HIGH CURRENT INSTRUMENTATION

A Pearson Model 1080 Current Probe is utilized as the sensor for the high current waveform measurement. The current probe is installed on the ground return of the High Current/Continuing Current Discharge Probe. The high current waveform measurement is telemetered via a Nanofast Model OP-300 Fiber Optic System. The signal is recorded on a Hewlett-Packard Model 54510 A/D Digital Oscilloscope and reduced on an IBM compatible PC.

2. INTERMEDIATE CURRENT INSTRUMENTATION

A Pearson Model 301X Current Probe is utilized as the sensor for the high current waveform measurement. The current probe is installed on the center conductor of the Intermediate Current Discharge Probe. The intermediate current waveform measurement is telemetered via a Nanofast Model OP-300 Fiber Optic System. The signal is recorded on an HP 54510 A/D Digital Oscilloscope and reduced on an IBM compatible PC.

3. CONTINUING CURRENT INSTRUMENTATION

A 0.12 Ohm series resistor is utilized as the sensor for the continuing current waveform measurement. The resistor is installed in-line with the continuing current transmission line. The continuing current waveform measurement is telemetered via a Meret Model MDL281-4-C Fiber Optic System. The signal is recorded on an HP 54510 A/D Digital Oscilloscope and reduced on an IBM compatible PC.

4. HIGH VOLTAGE RESTRIKE INSTRUMENTATION

A Pearson Model 1080 Current Probe is utilized as the sensor for the high voltage restrike waveform measurement. The current probe is installed on the center conductor of the High Voltage Restrike Down Conductor. The high voltage restrike waveform measurement is telemetered via a Nanofast Model OP-300 Fiber Optic System. The signal is recorded on an HP Model 54510 A/D Digital Oscilloscope and reduced on an IBM compatible PC.

VII. TEST PROCEDURE

The frustum and aft skirt panels were subjected to the simulated direct strike lightning environment described in Figure 1 to determine the structural effects of direct strike lightning on the frustum and aft skirt panels. The direct effects lightning test was divided into four phases: high current test; intermediate current test; continuing current test; and high voltage restrike test.

A. GENERAL TEST PROCEDURES

Operating procedures for the HELS facility are described in the "Hazardous Test Procedures For High Energy Lightning Simulator (HELS), AMSMI-RD-S-H-6", May 1987, and the associated Addendum dated 26 August 1988. The following is a general test procedure that was followed for each test sequence:

1. Perform pretest calibration of the simulated direct strike lightning generators on a frustum calibration panel.
2. Bolt a frustum test panel onto the ground return plate of the test fixture.
3. Install instrumentation and set up the high current (Component A) lightning generator and associated test equipment. Figures 7, 8, and 9 illustrate the test setup for the high current lightning test.
4. Charge high current lightning generator.
5. Initiate video recording sequence.
6. Discharge to the center portion of the frustum panel.
7. Record test data (Appendix C).
8. Repeat steps 2 through 7 for the remaining two frustum test panels.
9. Repeat steps 1 through 8 for the three aft skirt test panels.
10. Repeat steps 1 through 9 for the intermediate current (Component B) lightning generator. Figures 10, 11, and 12 illustrate the test setup for the intermediate current lightning test.
11. Repeat steps 1 through 9 for the continuing current (Component C) lightning generator. The test setup for the continuing current lightning test was identical to the test setup for the high current lightning test (see Figures 7, 8, and 9) except the discharge probe was positioned 0.25 inches from the panel.

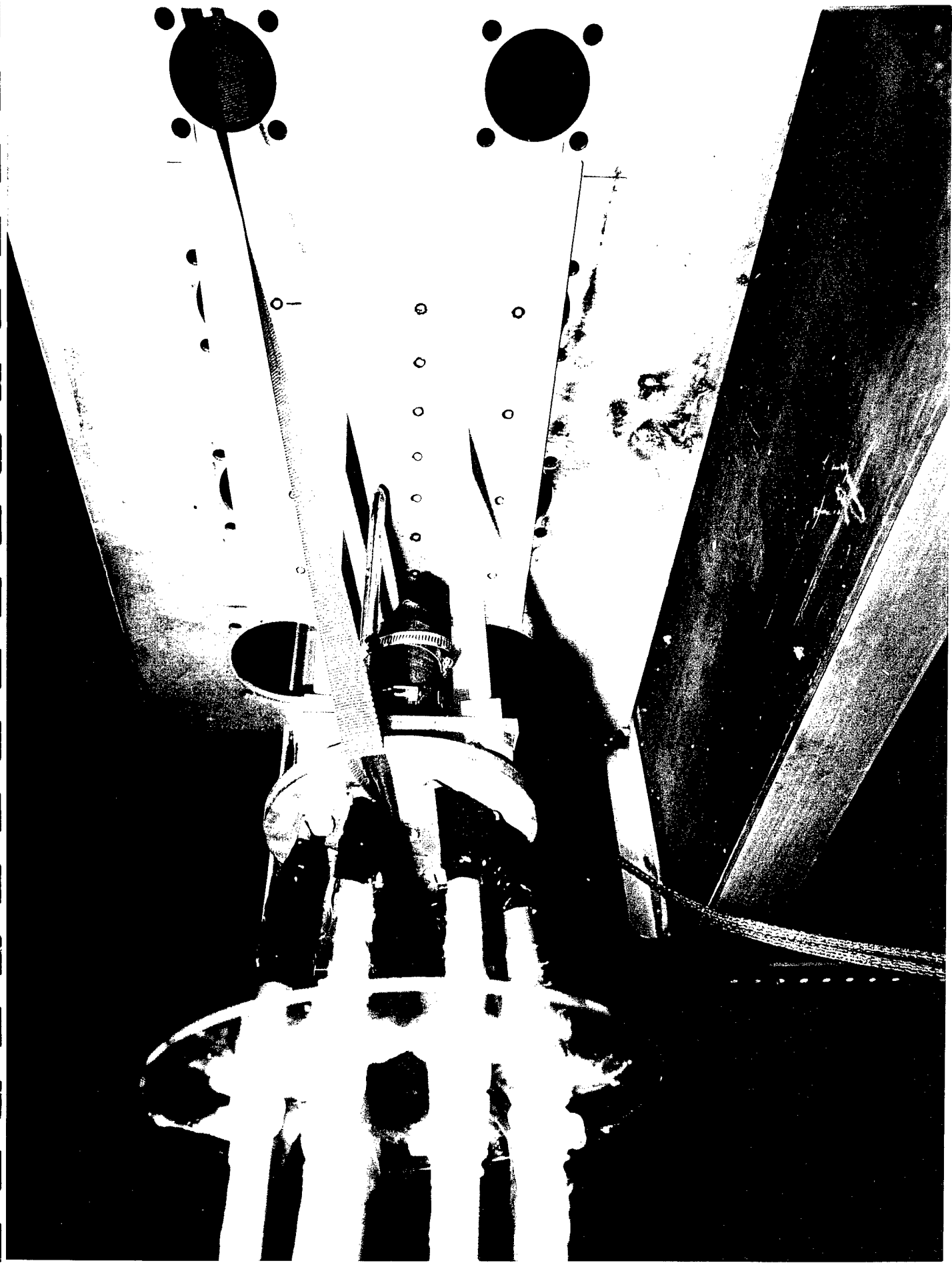

Figure 7. Test Setup for High Current and Continuing Current Lightning Tests.

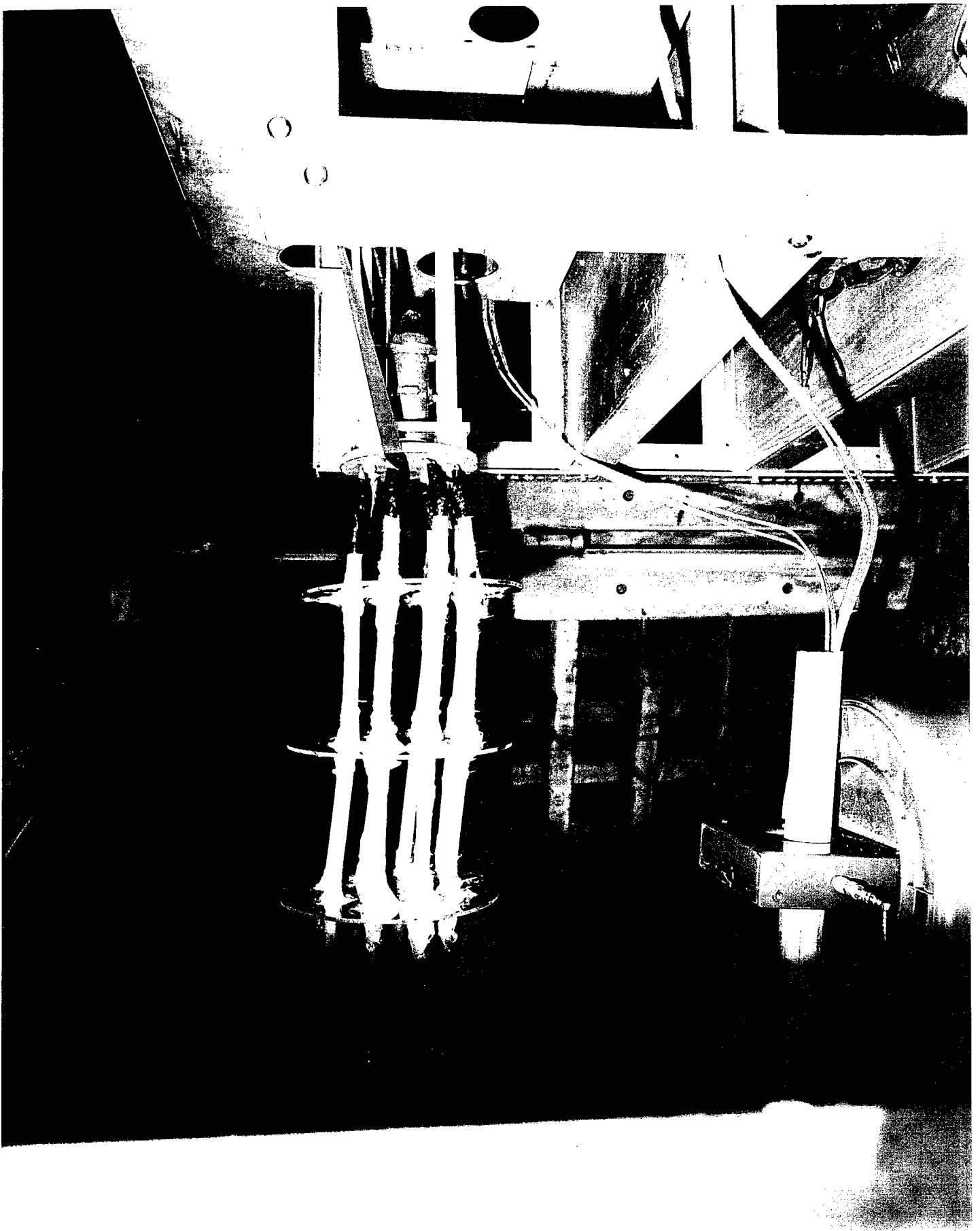

Figure 8. Test Setup for High Current and Continuing Current Lightning Tests.

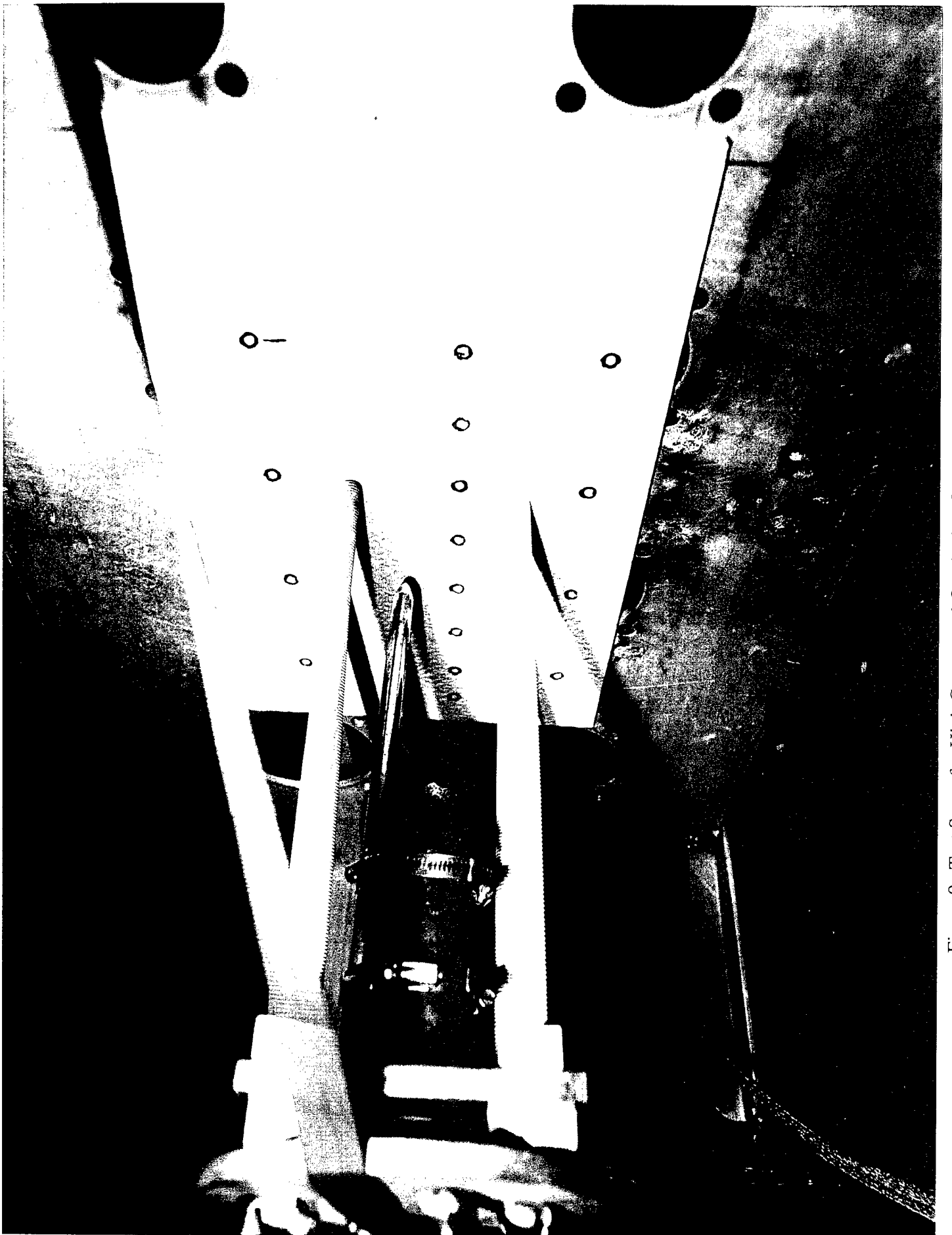

Figure 9. Test Setup for High Current and Continuing Current Lightning Tests.

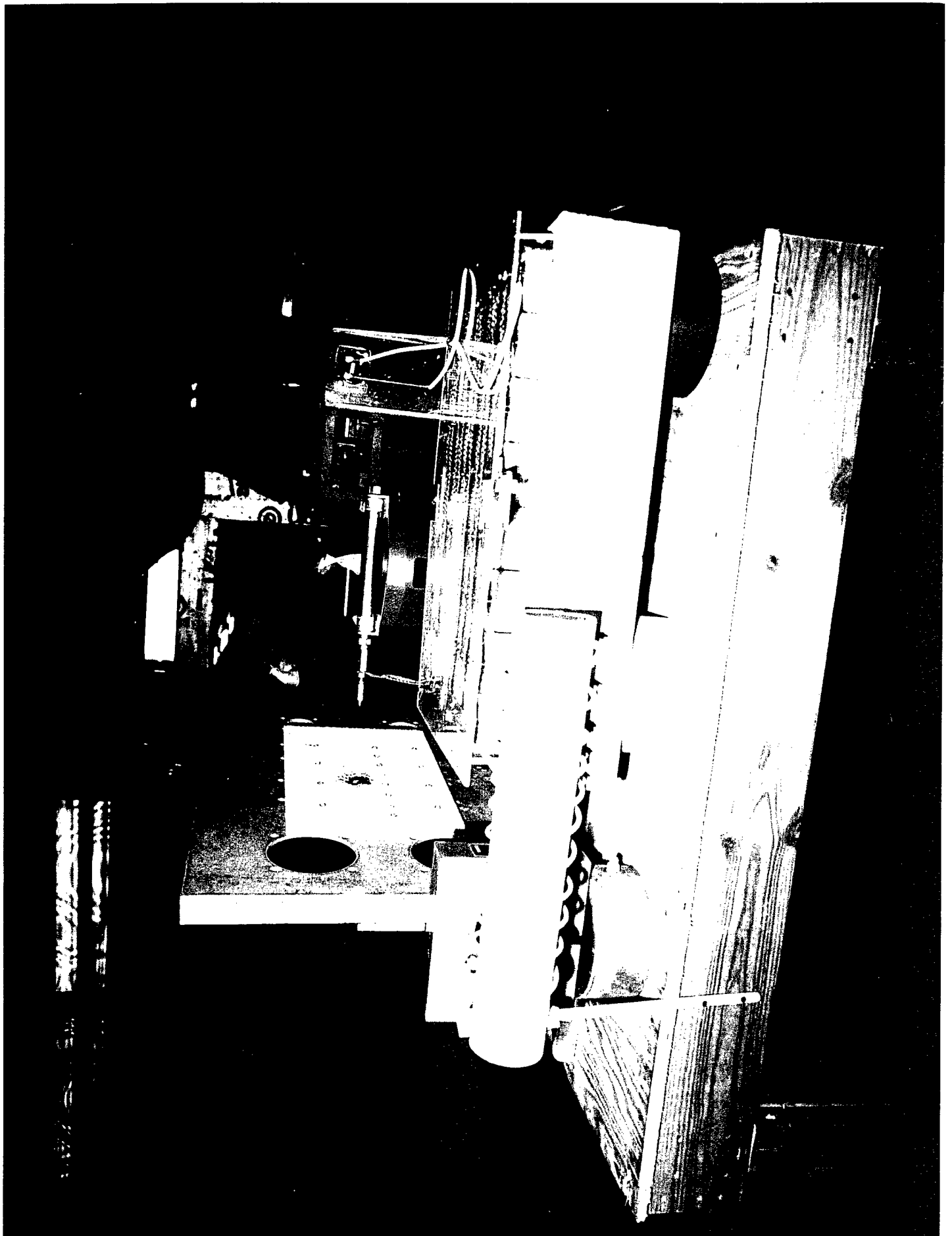

Figure 10. Test Setup for the Intermediate Current Lightning Test.

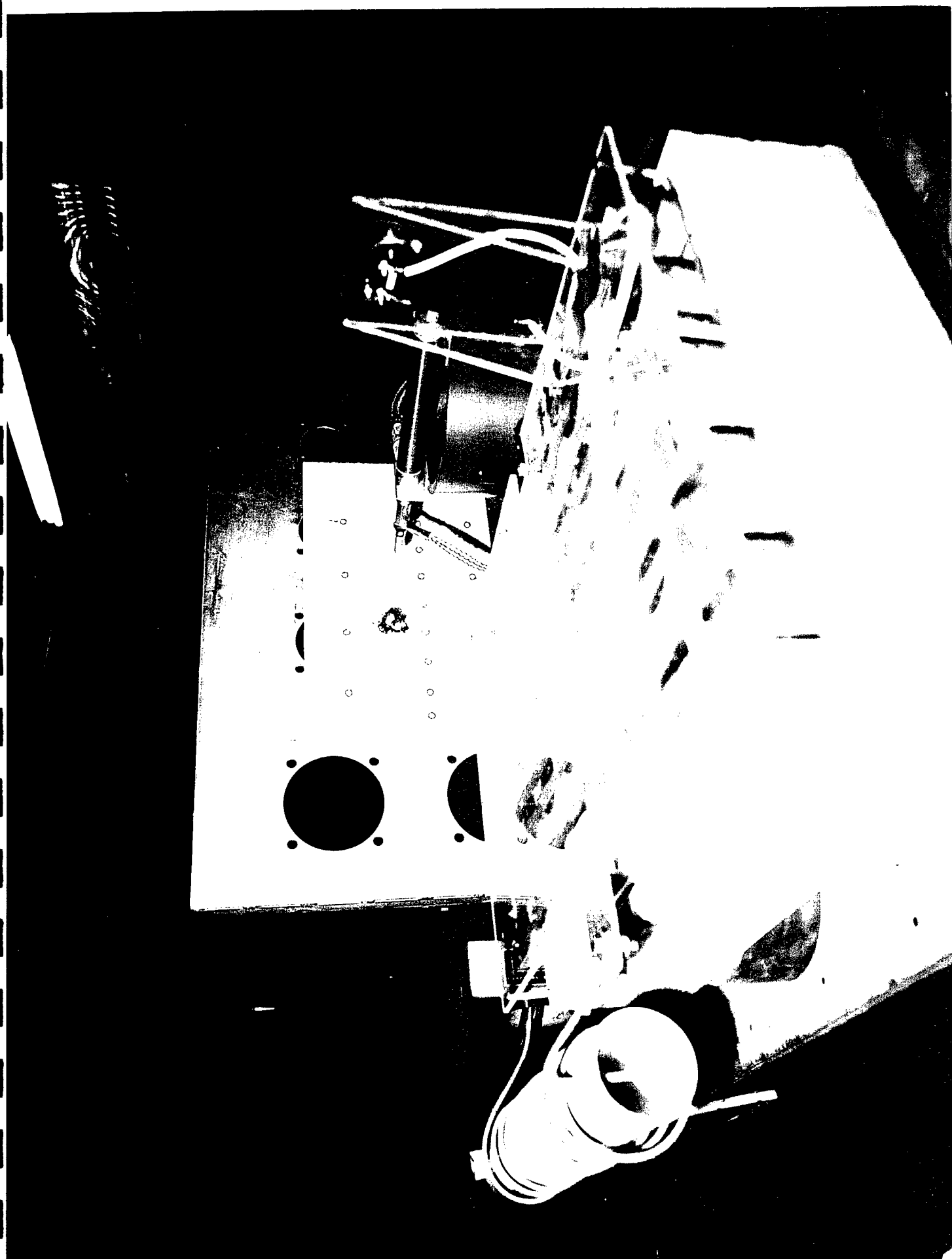

Figure 11. Test Setup for the Intermediate Current Lightning Test.

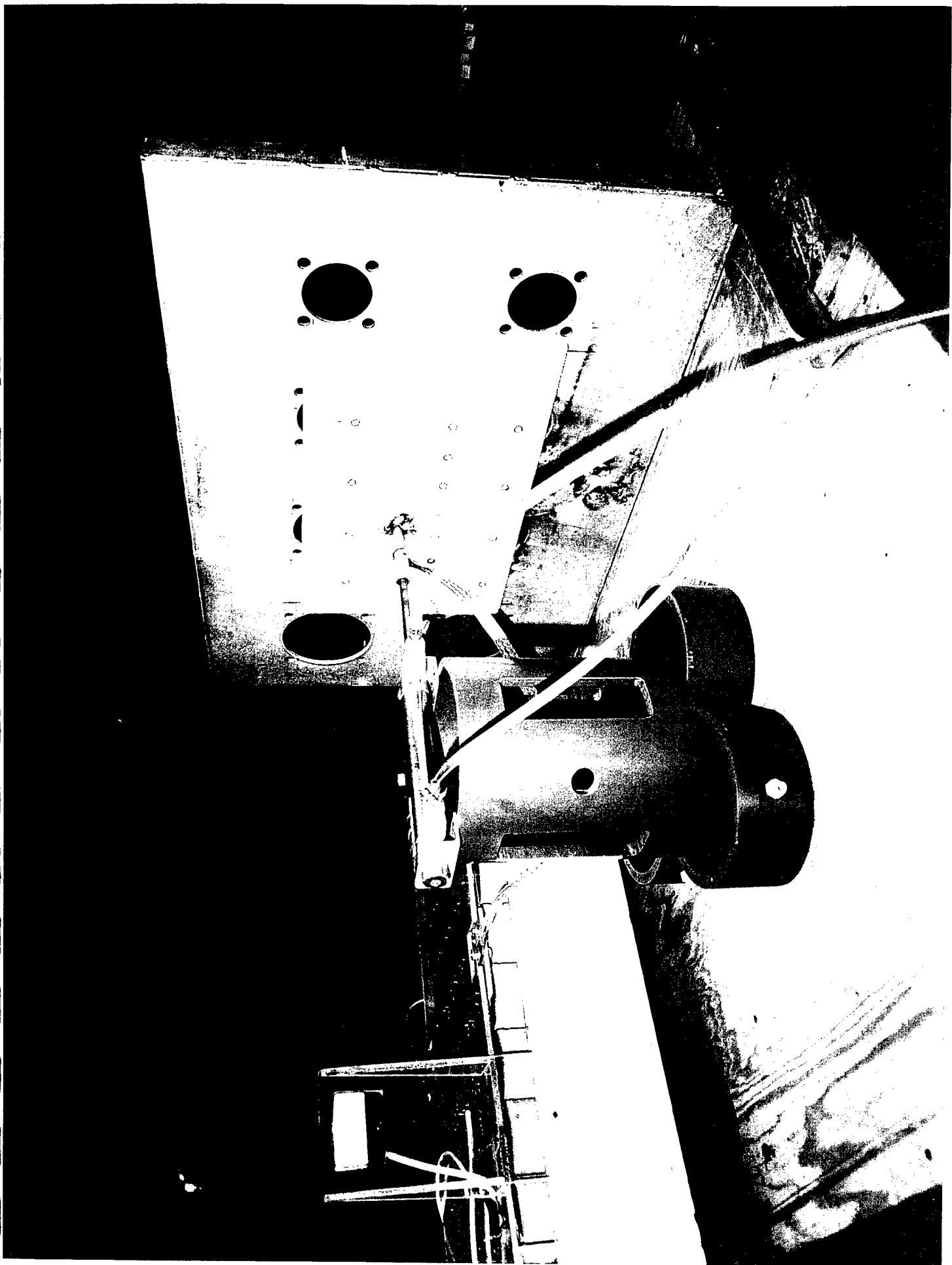

Figure 12. Test Setup for the Intermediate Current Lightning Test.

12. Repeat steps 1 through 9 for the restrike current (Component D) lightning generator. Figures 13 and 14 illustrate the test setup for the restrike current lightning test.

B. DEVIATIONS TO THE TEST PLAN

Four exceptions from the original test procedures (Appendix A) were taken during the direct strike lightning test of the MCC-1 TPS coated aluminum frustum and aft skirt panels. The first deviation was to conduct the high current (Component A) lightning test with the discharge probe positioned one inch from the panels rather than two inches. The second deviation consisted of utilizing only one each of the frustum and aft skirt calibration panels rather than all three of each. The third deviation was to subject frustum panel Q6#9 to two high current (Component A) attachments. The fourth deviation was to subject the two remaining frustum calibration panels to the high current (Component A) and the continuing current (Component C) direct strike lightning waveforms.

The first deviation was necessary to allow the high current lightning generator to maintain the specification level discharge to the test item. This deviation allowed the high current component to be tested similar to the TO2 test procedure of MIL-STD-1757. The TO2 test procedure of MIL-STD-1757 requires the gap between the discharge probe and the test item be 50 millimeters (mm) or approximately two inches for Component A and D tests to prevent the arc jet and blast pressure effects from influencing the test results.

The second deviation from the test procedures was to utilize only one frustum and one aft skirt calibration panel for calibration of the direct strike waveforms. It was not necessary to utilize all three of each of the frustum and the aft skirt calibration panels to calibrate the direct strike lightning waveforms. The same frustum and aft skirt calibration panels were utilized throughout the test in order to insure proper calibration with respect to the cumulative damage on the panels.

The third deviation from the test procedures was to subject frustum panel Q6#9 to two high current (Component A) attachments. This was necessary in order to record the correct high current direct strike lightning waveform measurement. On the first high current attachment to frustum panel Q6#9, the instrumentation system malfunctioned. A second high current attachment, at a different location, was necessary in order to correctly record the test waveform.

The fourth deviation from the test procedures was to subject the two remaining frustum calibration panels to the high current and continuing current direct strike lightning environment. Frustum calibration panel TTC5#16 was subjected to the high current (Component A) direct strike lightning environment with the discharge probe touching (no gap) the panel. This was done to compare the structural damage difference to the test panels which utilized a 1-inch gap between the discharge probe and the test panel. Frustum calibration panel TTC5#13 was subjected to the simultaneous high current (Component A) and continuing current (Component C) direct strike lightning environment with a separation distance of 1/4-inch between the discharge probe and the panel. This was done to compare the structural damage difference from the simultaneous application of the high current and continuing current direct strike lightning environment to the structural damage due to separate applications of these direct strike lightning environments.

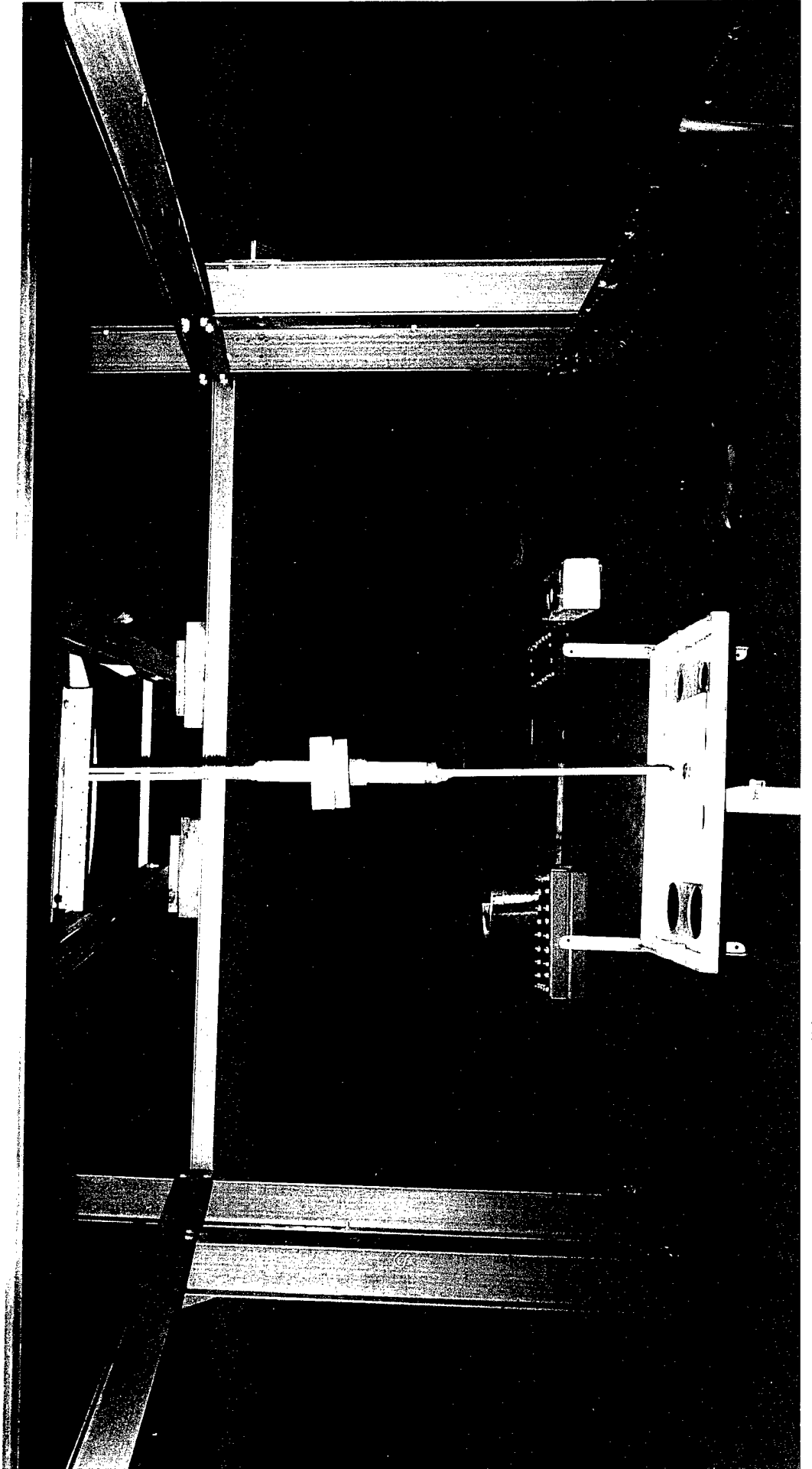
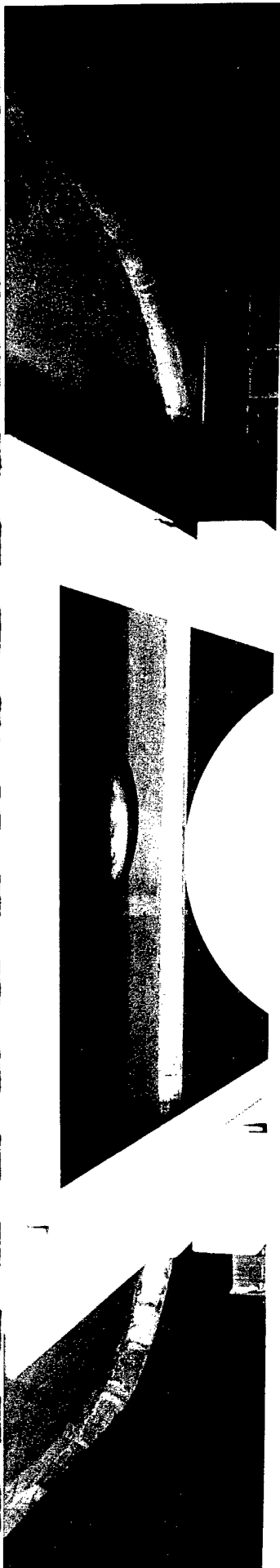

Figure 13. Test Setup for the Restrike Current Lightning Test.

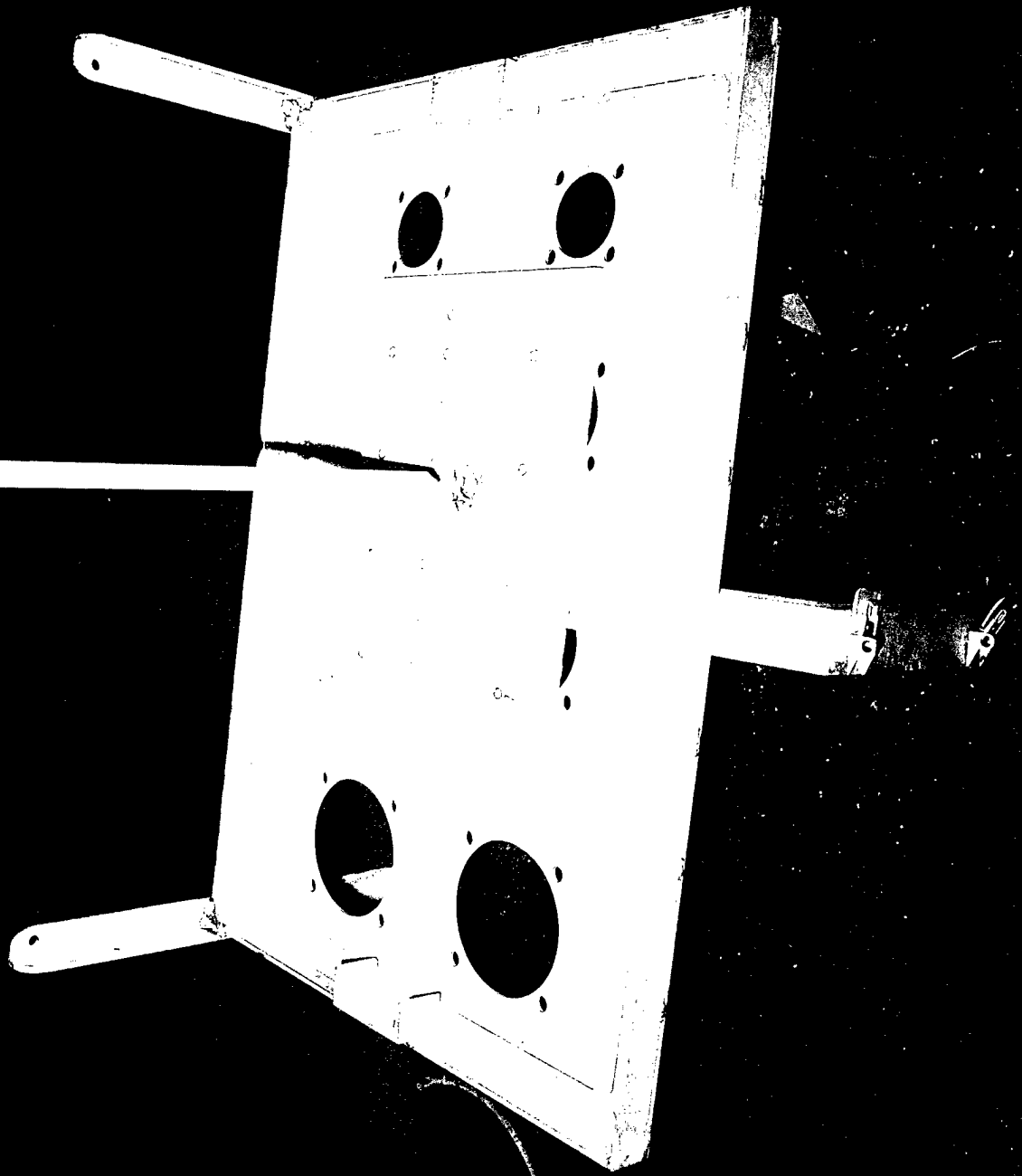

Figure 14. Test Setup for the Restrike Current Lightning Test.

VIII. RESULTS

All of the panels experienced loss of MCC-1 TPS coating at the point of discharge due to the application of the high current (Component A) direct strike lightning environment. The amount of MCC-1 TPS coating loss varied from panel to panel and seemed to depend on how well the material was bonded to the aluminum panel. For instance, comparison of the two separate attachments to frustum panel Q6#9 indicates different degrees of MCC-1 TPS coating loss. The first high current attachment resulted in a large area of loss of MCC-1 TPS coating while the second high current attachment resulted in significantly less loss of MCC-1 TPS coating. Additionally, the high current attachment to frustum panel Q13#2 resulted in the loss of a large circular section of MCC-1 TPS coating. The MCC-1 TPS coating was recovered in two approximately semi-circular solid pieces instead of being shattered into smaller pieces. Again, the degree of bonding of the MCC-1 TPS material to the aluminum panel appeared to be a determining factor in the amount of MCC-1 TPS coating loss. Figures B-1 through B-18 of Appendix B illustrate the damage on each panel due to the application of the Component A direct strike lightning waveform.

The application of the intermediate current (Component B) direct strike lightning environment resulted in a small melted (burn or blistered) spot on the aluminum panels approximately 1/4-inch in diameter. No additional loss of MCC-1 TPS coating was observed to occur due to the application of the intermediate current direct strike lightning environment. Figures B-19 through B-36 of Appendix B illustrate the cumulative damage on each panel due to the applications of the Component A and the Component B direct strike lightning waveforms.

The application of the continuing current (Component C) direct strike lightning environment resulted in a melted (burn or blistered) spot on the aluminum panels of up to approximately 3/4-inch in diameter. No additional loss of MCC-1 TPS coating was observed to occur due to the application of the intermediate current direct strike lightning environment. Figures B-37 through B-54 of Appendix B illustrate the cumulative damage on each panel due to the applications of the Component A, the Component B, and the Component C direct strike lightning waveforms.

The application of the restrike current (Component D) direct strike lightning environment resulted in slight blackening of the MCC-1 TPS coating around the area of the discharge point. No additional loss of MCC-1 TPS coating was observed to occur due to the application of the intermediate current direct strike lightning environment. Figures B-55 through B-72 of Appendix B illustrate the cumulative damage on each panel due to the applications of the Component A, the Component B, the Component C, and the Component D direct strike lightning waveforms.

The application of the high current (Component A) direct strike lightning environment to frustum calibration panel TTC5#16 with the discharge probe touching the panel did not appear to result in any significant difference of loss of MCC-1 TPS coating than to the test panels which utilized a 1-inch gap between the discharge probe and the test panels. Figures B-73 through B-75 of Appendix B illustrate the damage on the panel due to the application of the Component A direct strike lightning waveform.

The simultaneous application of the high current (Component A) and the continuing current (Component C) lightning environment to frustum calibration panel TTC5#13 resulted in the loss of MCC-1 TPS coating and melting (burn or blistering) similar to the test panels. The significant difference was that the MCC-1 TPS coating ignited and burned as a result of the simultaneous application of the high current and continuing current direct strike lightning environment. Figures B-76 through B-78 of Appendix B illustrate the damage on the panel due to the simultaneous application of the Component A and the Component C direct strike lightning waveforms.

TABLE 1. DIRECT STRIKE LIGHTNING TEST MEASUREMENTS

| Test No. | Panel Type | File No. | Panel No. | Comp. A | | Comp. B | | Comp. C | | Comp. D | | Comments |
|----------|------------|----------|-----------|-------------------|--------------------------------------|------------------|------------|------------------|------------|-------------------|--------------------------------------|---|
| | | | | Peak Current (kA) | Action integral (A ² sec) | Peak Current (A) | Charge (C) | Peak Current (A) | Charge (C) | Peak Current (kA) | Action integral (A ² sec) | |
| 1 | Frustum | SRBCALA1 | | 201 | 1.82x10 ⁶ | x | x | x | x | x | x | Calibration; See Fig. C-1 |
| 2 | Aft Skirt | SRBCALA2 | | 196 | 1.80x10 ⁶ | x | x | x | x | x | x | Calibration; See Fig. C-2 |
| 3 | Frustum | SS1Q6#9A | Q6#9 | x | x | x | x | x | x | x | x | Instr Error; See Fig. B-1, B-2 and C-3 |
| 4 | Frustum | SS2Q6#9A | Q6#9 | 206 | 1.94x10 ⁶ | x | x | x | x | x | x | See Fig. B-3, B-4 and C-4 |
| 5 | Frustum | SIQ6#10A | Q6#10 | 207 | 1.95x10 ⁶ | x | x | x | x | x | x | See Fig. B-5, B-6 and C-5 |
| 6 | Frustum | SIQ3#2A | Q13#2 | 206 | 1.92x10 ⁶ | x | x | x | x | x | x | See Fig. B-7 thru B-12 and C-6 |
| 7 | Aft Skirt | SIQ11#6A | Q11#6 | 207 | 1.97x10 ⁶ | x | x | x | x | x | x | See Fig. B-13, B-14 and C-7 |
| 8 | Aft Skirt | SIQ11#8A | Q11#8 | 204 | 1.88x10 ⁶ | x | x | x | x | x | x | See Fig. B-15, B-16 and C-8 |
| 9 | Aft Skirt | SIQ11#9A | Q11#9 | 202 | 1.84x10 ⁶ | x | x | x | x | x | x | See Fig. B-17, B-18 and C-9 |
| 10 | Frustum | SRBCALB1 | | x | x | 5476 | 10.0 | x | x | x | x | Calibration; See Fig. C-10 |
| 11 | Aft Skirt | SRBCALB2 | | x | x | 5123 | 9.3 | x | x | x | x | Calibration; See Fig. C-11 |
| 12 | Frustum | SS1Q6#9B | Q6#9 | x | x | 5679 | 10.3 | x | x | x | x | See Fig. B-19 thru B-21 and C-12 |
| 13 | Frustum | SIQ6#10B | Q6#10 | x | x | 5716 | 10.3 | x | x | x | x | See Fig. B-22 thru B-24 and C-13 |
| 14 | Frustum | SIQ13#2B | Q13#2 | x | x | 5679 | 10.3 | x | x | x | x | See Fig. B-25 thru B-27 and C-14 |
| 15 | Aft Skirt | SIQ11#6B | Q11#6 | x | x | 5679 | 10.3 | x | x | x | x | See Fig. B-28 thru B-30 and C-15 |
| 16 | Aft Skirt | SIQ11#8B | Q11#8 | x | x | 5603 | 10.1 | x | x | x | x | See Fig. B-31 thru B-33 and C-16 |
| 17 | Aft Skirt | SIQ11#9B | Q11#9 | x | x | 5565 | 10.1 | x | x | x | x | See Fig. B-34 thru B-36 and C-17 |
| 18 | Frustum | SRBCALC1 | | x | x | x | x | 200 | 200 | x | x | Calibration; See Fig. C-18 |
| 19 | Frustum | SS1Q6#9C | Q6#9 | x | x | x | x | 200 | 200 | x | x | Probe Contact Too Good; See Fig. C-19 |
| 20 | Frustum | SS2Q6#9C | Q6#9 | x | x | x | x | 203 | 203 | x | x | See Fig. B-37 thru B-39 and C-20 |
| 21 | Frustum | SIQ6#10C | Q6#10 | x | x | x | x | 204 | 204 | x | x | See Fig. B-40 thru B-42 and C-21 |
| 22 | Frustum | SIQ13#2C | Q13#2 | x | x | x | x | 204 | 204 | x | x | See Fig. B-43 thru B-45 and C-22 |
| 23 | Aft Skirt | SIQ11#6C | Q11#6 | x | x | x | x | 207 | 207 | x | x | See Fig. B-46 thru B-48 and C-23 |
| 24 | Aft Skirt | SIQ11#8C | Q11#8 | x | x | x | x | 199 | 199 | x | x | See Fig. B-49 thru B-51 and C-24 |
| 25 | Aft Skirt | S2Q11#9C | Q11#9 | x | x | x | x | 203 | 203 | x | x | See Fig. B-52 thru B-54 and C-25 |
| 26 | Frustum | SRBCALD1 | | x | x | x | x | x | x | 92 | 0.39x10 ⁶ | Calibration; See Fig. C-26 |
| 27 | Aft Skirt | SRBCALD2 | | x | x | x | x | x | x | 91 | 0.35x10 ⁶ | Calibration; See Fig. C-27 |
| 28 | Frustum | SS1Q6#9D | Q6#9 | x | x | x | x | x | x | 93 | 0.39x10 ⁶ | See Fig. B-55 thru B-57 and C-28 |
| 29 | Frustum | SIQ6#10D | Q6#10 | x | x | x | x | x | x | 92 | 0.42x10 ⁶ | See Fig. B-58 thru B-60 and C-29 |
| 30 | Frustum | SIQ13#2D | Q13#2 | x | x | x | x | x | x | 94 | 0.40x10 ⁶ | See Fig. B-61 thru B-63 and C-30 |
| 31 | Aft Skirt | SIQ11#6D | Q11#6 | x | x | x | x | x | x | 91 | 0.35x10 ⁶ | See Fig. B-64 thru B-66 and C-31 |
| 32 | Aft Skirt | SIQ11#8D | Q11#8 | x | x | x | x | x | x | 94 | 0.39x10 ⁶ | See Fig. B-67 thru B-69 and C-32 |
| 33 | Aft Skirt | SIQ11#9D | Q11#9 | x | x | x | x | x | x | 92 | 0.43x10 ⁶ | See Fig. B-70 thru B-72 and C-33 |
| 34 | Frustum | TTC5#16A | TTC5#16 | 209 | 1.88x10 ⁶ | x | x | x | x | x | x | No Gap; See Fig. B-73 thru B-75 and C-34 |
| 35 | Frustum | TC5#13AC | TTC5#13 | 209 | 1.99x10 ⁶ | 471 | 167 | x | x | x | x | Ignited; See Fig. B-76 thru B-78, C-35 and C-36 |

APPENDIX A

DIRECT STRIKE LIGHTNING EFFECTS TEST PROCEDURES FOR THE MCC-1
TPS COATED ALUMINUM PANELS

DIRECT STRIKE LIGHTNING EFFECTS TEST PROCEDURES FOR THE MCC-1
TPS COATED ALUMINUM PANELS

6 January 1995

Jeffery D. Craven
Electromagnetic Environmental Effects Test Branch
Electro-Mechanical Test Division
Redstone Technical Test Center

I. INTRODUCTION

As part of the SRB TPS replacement program qualification test effort, the MCC-1 is required to be subjected to lightning testing as specified in NSTS 07636 Rev. G to verify that the design is sufficient to ensure the protection of the space shuttle from the direct and indirect effects of lightning. The particular scope of this test effort is to determine the structural direct effects of lightning to the frustum and aft skirt panels. The frustum panel has dimensions of 12 x 20 inch with an aluminum thickness of 0.125 inches and a TPS thickness of 0.190 inches. The aft skirt panel has an aluminum thickness of 0.25 inches and a TPS thickness of 0.460 inches.

II. TEST OBJECTIVE

The objective of this lightning effects test is to determine and assess the structural direct effects of lightning to the frustum and aft skirt panels of the space shuttle. This effort will not assess the indirect effects of lightning from a direct strike, nor near strike, lightning event on the frustum or aft skirt panels.

III. TEST ENVIRONMENT

The environments required for this test effort are for Zone 1B type lightning strikes as specified in MIL-STD-1757A. Since the objective of this test effort is to determine the structural direct effects of lightning to the frustum and aft skirt panels of the space shuttle, test method T02 of MIL-STD-1757A will be utilized to test lightning current waveform Components A, B, C, and D. The requirements for these lightning current waveform components are defined in Figure 1.

IV. EVALUATION CRITERIA

The criteria for this test effort is to determine that the MCC-1 TPS coated aluminum frustum and aft skirt panels are subjected to the specified lightning current environment.

V. TEST RESPONSIBILITY

A. Redstone Technical Test Center

The RTTC is responsible for planning and conducting all tests, coordinating and scheduling test facilities, establishing and applying security and safety procedures, providing system instrumentation and test fixtures, modifying test hardware as required, collecting and analyzing test data, and providing a final report or report letter.

B. United Technologies Corporation/United States Booster Incorporated

United Technologies Corporation/United States Booster Incorporated (UTC/USBI) is responsible for providing overall coordination of the test program, including, but not limited to, supplying technical assistance, providing funds, identifying and providing all test hardware, and support hardware, and for the evaluation of the frustum and aft skirt panels with respect to space shuttle flight safety and crew hazard.

VI. FACILITIES AND EQUIPMENT REQUIREMENTS

This section describes the test hardware, facility and instrumentation necessary to conduct the structural direct effects lightning test of the MCC-1 TPS coated aluminum frustum and aft skirt panels.

A. TEST HARDWARE

The test hardware will be provided by UTC/USBI and will consist of six frustum panels and six aft skirt panels coated with MCC-1 TPS (Figure 2). Three of the frustum panels, as well as three of the aft skirt panels, will be provided for calibration purposes.

B. FACILITY

This section describes the various components comprising the simulated direct strike lightning equipment of the Hazardous Lightning (HELS) Test Facility.

1. HIGH CURRENT CAPACITOR BANK

The high current (Component A) capacitor bank consists of 480 capacitors, each rated at 60 kV and 1.875 MF, configured as a two-stage Marx bank with a total capacitance of 56.25 MF and an output voltage of 220 kV. A 2.25 MF, 300 kV peaking capacitor circuit is utilized in conjunction with the high current capacitor bank to increase the current rate-of-rise time to 6.5 msec. The high current capacitor bank can generate a $200 \text{ kA} \pm 10\%$ peak current simulated Component A direct strike lightning waveform with an action integral of $2.0 \times 10^6 \text{ A}^2\text{sec} \pm 20\%$ (Figure 1b).

2. INTERMEDIATE CURRENT CAPACITOR BANK

The Intermediate Current (Component B) Capacitor Bank consists of 5 layers of electrolytic capacitors connected in series. Each layer contains 8, 450 volt, 3000 MF capacitors in parallel. The total calculated capacitance is 4800 MF. The charge voltage is 2100 V. The intermediate current capacitor bank can generate a 2000 A 10% simulated direct strike Component B waveform with a peak current of approximately 5800 A and 10 Coulombs (C) of charge transfer (Figure 1b).

3. CONTINUING CURRENT CAPACITOR BANK

The Continuing Current (Component C) Capacitor Bank consists of two layers of electrolytic capacitors connected in series. Each layer contains 196, 450 volt, 3000 MF capacitors in parallel. The total measured capacitance is 0.37 F when charged to a nominal value of 750 V. The continuing current capacitor bank can generate a simulated Component C waveform with $200 \text{ C} \pm 20\%$ of charge transfer (Figure 1c).

4. HIGH VOLTAGE RESTRIKE MARX CAPACITOR BANK

The High Voltage Restrike Marx (Component D) Capacitor Bank is an 18 stage Marx bank with a total capacitance of 0.9375 MF. Each stage, consisting of nine 60 kV, 1.875 MF capacitors in parallel, is normally charged to 42 kV to provide a total output voltage of 756 kV. Energy from the Marx bank is delivered to the peaking capacitor/spark gap assembly via an one-inch insulated conductor. The peaking capacitor bank has a total capacitance of 0.027 MF and a maximum voltage capability of 2.2 megavolts. The peaking capacitor bank consists of two parallel stacks of Maxwell

capacitors. Each stack contains twenty-two 0.3 mF, 100 kV capacitors in series. The high voltage restrike Marx capacitor bank can generate a 100 kA \pm 10% peak current simulated Component D waveform with an average current rate-of-rise of 1.0×10^{11} A/sec and a maximum current rate-of-rise of 1.4×10^{11} A/sec \pm 20% (Figure 1c).

C. TEST INSTRUMENTATION

The objective of the test effort was to subject the frustum and aft skirt panels to a simulated direct strike lightning test to determine the direct effects only; therefore, only the injection current waveforms are necessary to monitor to insure compliance with the simulated direct strike lightning environment criteria. Instrumentation of the frustum or aft skirt panels were not necessary.

1. HIGH CURRENT INSTRUMENTATION

A Pearson Model 1080 Current Probe is utilized as the sensor for the high current waveform measurement. The current probe is installed on the center conductor of the High Current/Continuing Current Discharge Probe. The high current waveform measurement is telemetered via a Nanofast Model OP-300 Fiber Optic System. The signal is recorded on a Hewlett-Packard Model 54510 A/D Digital Oscilloscope and reduced on an IBM compatible PC.

2. INTERMEDIATE CURRENT INSTRUMENTATION

A ??? Ohm series resistor is utilized as the sensor for the intermediate current waveform measurement. The resistor is installed in-line with the intermediate current transmission line. The intermediate current waveform measurement is telemetered via a Meret Model MDL281-4-C Fiber Optic System. The signal is recorded on an HP 54510 A/D Digital Oscilloscope and reduced on an IBM compatible PC.

3. CONTINUING CURRENT INSTRUMENTATION

A 0.12 Ohm series resistor is utilized as the sensor for the continuing current waveform measurement. The resistor is installed in-line with the continuing current transmission line. The continuing current waveform measurement is telemetered via a Meret Model MDL281-4-C Fiber Optic System. The signal is recorded on an HP 54510 A/D Digital Oscilloscope and reduced on an IBM compatible PC.

4. HIGH VOLTAGE RESTRIKE INSTRUMENTATION

A Pearson Model 1080 Current Probe is utilized as the sensor for the high voltage restrike waveform measurement. The current probe is installed on the center conductor of the High Voltage Restrike Down Conductor. The high voltage restrike waveform measurement is telemetered via a Nanofast Model OP-300 Fiber Optic System. The signal is recorded on an HP Model 54510 A/D Digital Oscilloscope and reduced on an IBM compatible PC.

VII. TEST PROCEDURE

The frustum and aft skirt panels will be subjected to the simulated direct strike lightning environment described in Figure 1 to determine the structural direct effects of lightning on the frustum and aft skirt panels. The direct effects lightning test will be divided into four phases: high current test ; intermediate current test; continuing current test; and high voltage restrike test.

A. GENERAL TEST PROCEDURES

Operating procedures for the HELS facility are described in the "Hazardous Test Procedures For High Energy Lightning Simulator (HELS)", AMSMI-RD-S-H-6, May 1987, and the associated Addendum dated 26 August 1988. The following is a general test procedure that will be followed for each test sequence:

1. Perform pretest calibration of the simulated direct strike lightning generators on the frustum and aft skirt calibration panels.
2. Bolt the frustum panel onto the ground return plate of the test fixture.
3. Install instrumentation and set up the high current (Component A) lightning generator and associated test equipment.
4. Charge high current lightning generator.
5. Initiate video recording sequence.
6. Discharge to the center portion of the frustum panel.
7. Record test data.
8. Repeat steps 2 through 7 for the remaining five frustum panels.
9. Repeat steps 2 through 7 for the six aft skirt panels.
10. Repeat steps 2 through 9 for the intermediate current (Component B) lightning generator.
11. Repeat steps 2 through 9 for the continuing current (Component C) lightning generator.
12. Repeat steps 2 through 9 for the restrike current (Component D) lightning generator.

VIII. DOCUMENTATION

General documentation for the structural direct effects lightning test includes the following, but is not limited to:

- * Serial numbers of test hardware (if applicable) and calibration information
- * Non-standard modification of test hardware
- * Hardware configuration
- * Non-test related problems/failures
- * Pre-test, post-test, etc. inspection results
- * Daily log for test activities

- * Direct strike lightning generator/power supply used, including ancillary equipment

- * Four sets of color 8 x 10 inch still photographs of test setup

- * Four sets of color 8 x 10 inch still photographs of each panel before and after test

- * Two copies of video photography of the lightning strike test events.

Detailed documentation for each test run shall include the following, but is not limited to:

- * Test run number

- * Test criteria

- * Direct strike lightning current waveforms and test parameters

- * Results of visual inspection of the frustum and aft skirt panels.

APPENDIX B
PHOTOGRAPHS

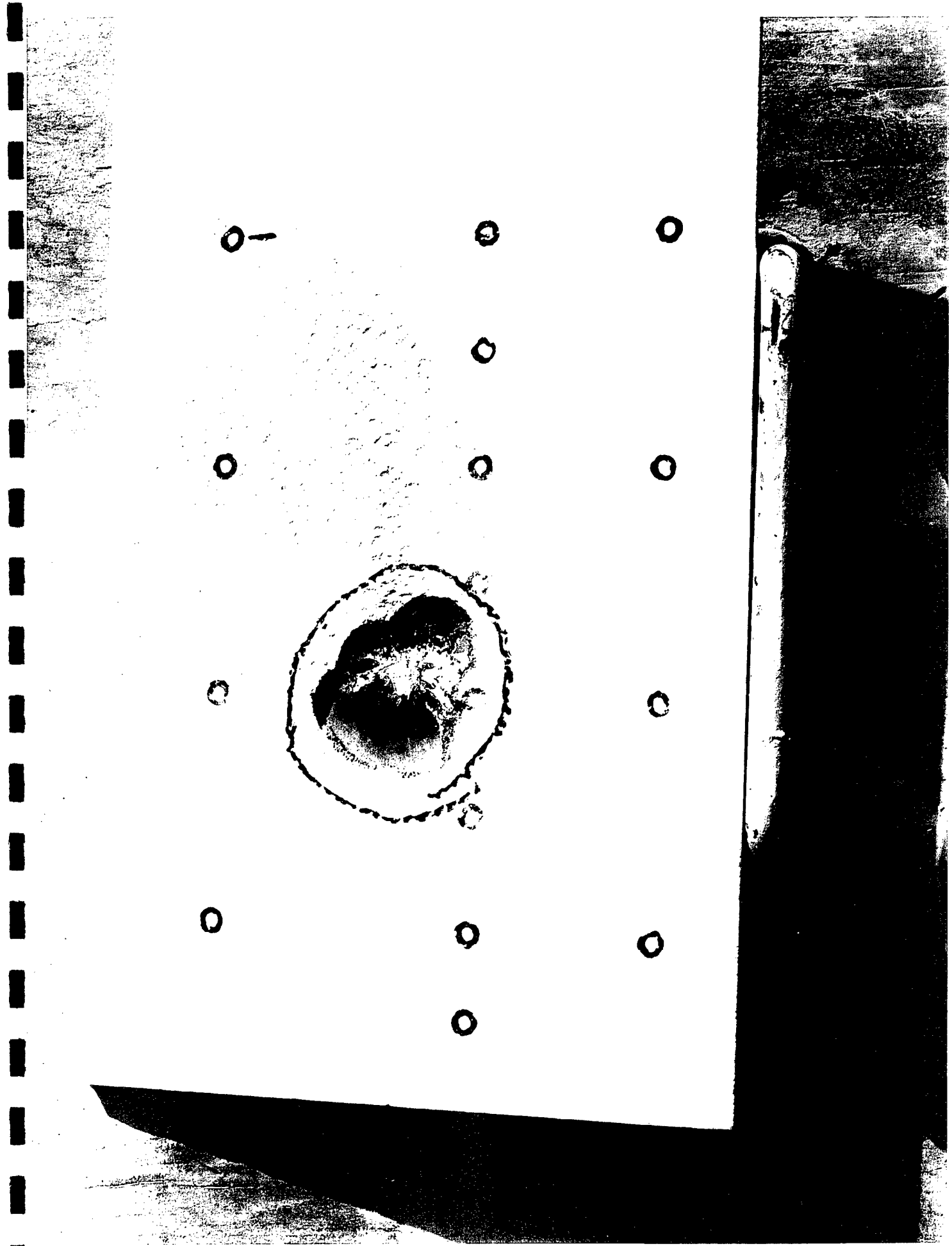

Figure B-1. Resultant Damage Due to Component A to Panel Q-6#9, Front View.

6#9-0

4.3.22
8-22-94
86#9
Top

3 3/8" Nominal
Lightning Strike Pan

READING EDGE 3.1

Figure B-2. Resultant Damage Due to Component A to Panel Q-6#9, Back View.

Row 55ZQ6 #9A

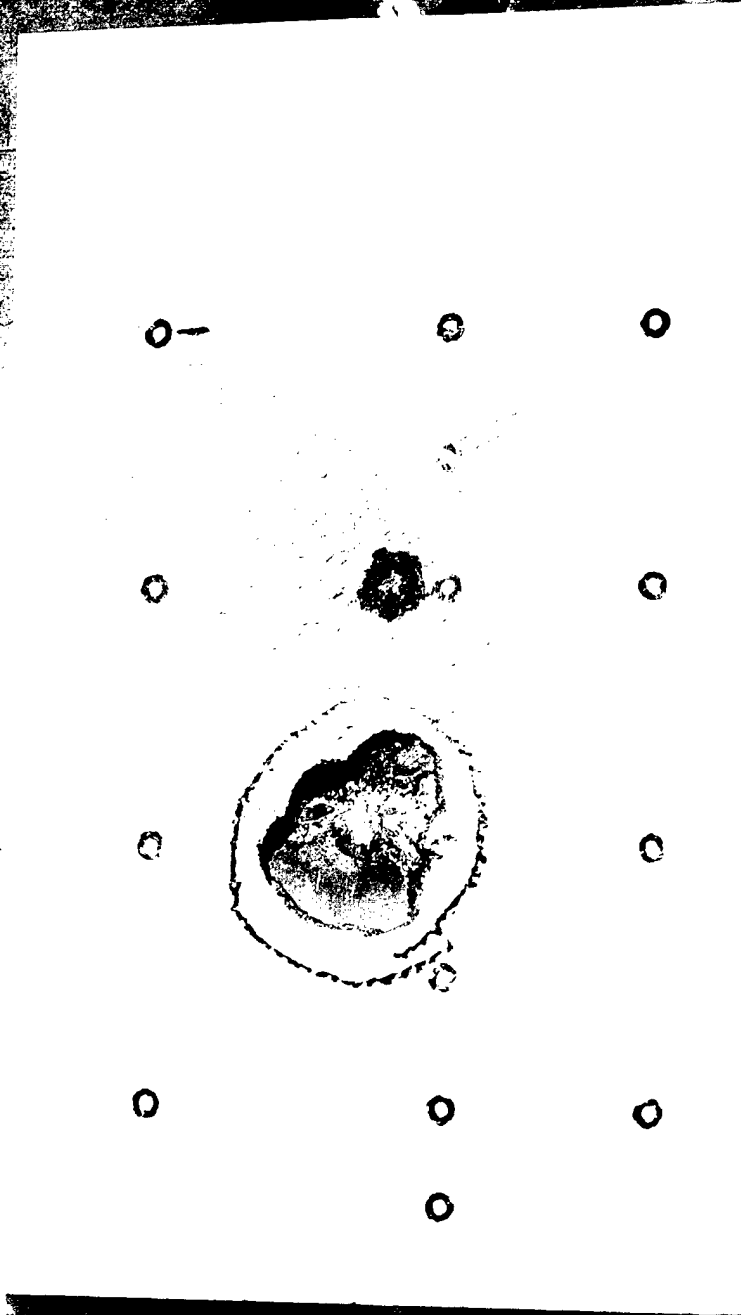

Figure B-3. Resultant Damage Due to Component A to Panel Q-6#9, Front View (2nd Test).

Run 552Q6 #9A

6#9-0

TOP
860 #9
8-22-94
4.3.32

3 1/2" Nominal
Lightning Strike Run

MINING EDGE 3.1

Figure B-4. Resultant Damage Due to Component A to Panel Q-6#9. Back View (2nd Test).

RUN SIG610A
FRUSTUM

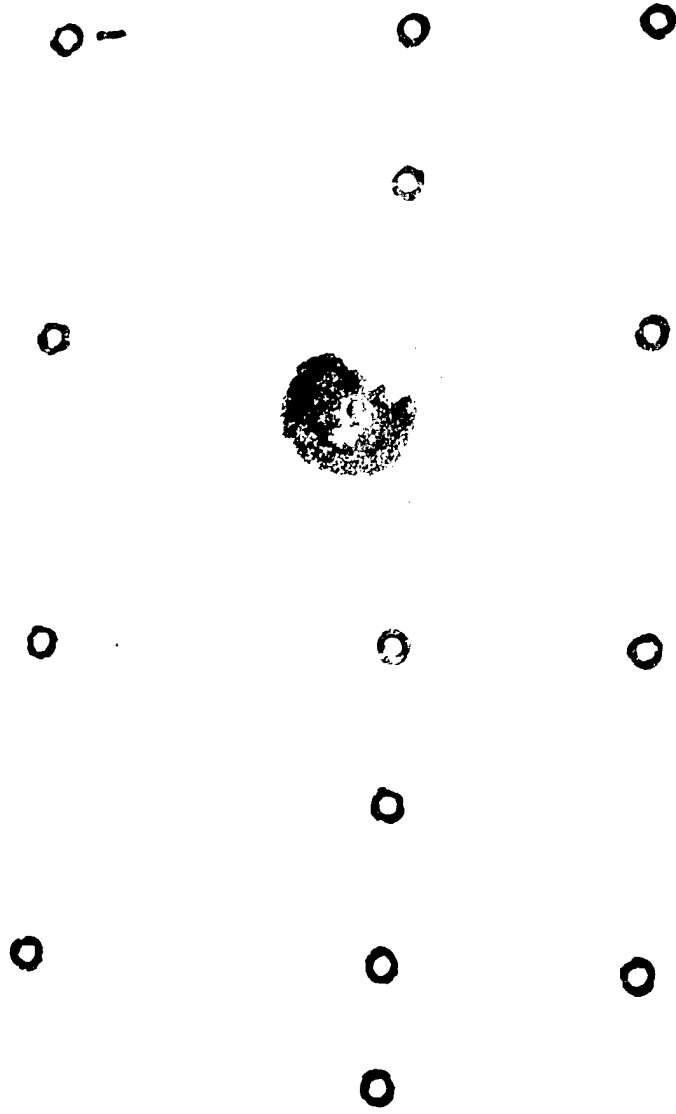

Figure B-5. Resultant Damage Due to Component A to Panel Q-6#10, Front View.

RUN 51Q610A
FRUSTUM

Q-6#10

TOP
Q6 #10
Q-2-94
4.3.37

3/16 Terminal
Lightly strike round

READER
ED: E

Figure B-6. Resultant Damage Due to Component A to Panel Q-6#10, Back View.

RUNSIQ13ZA

FRUSTUM

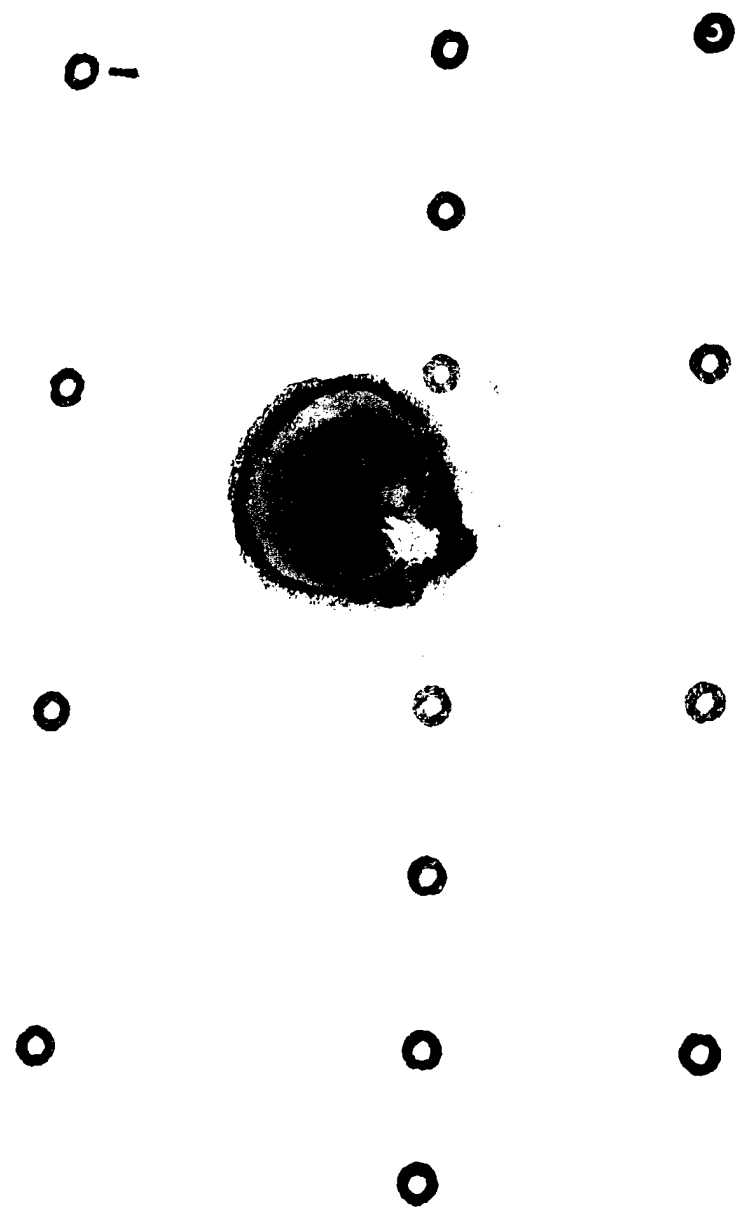

Figure B-7. Resultant Damage Due to Component A to Panel Q-13#2, Front View.

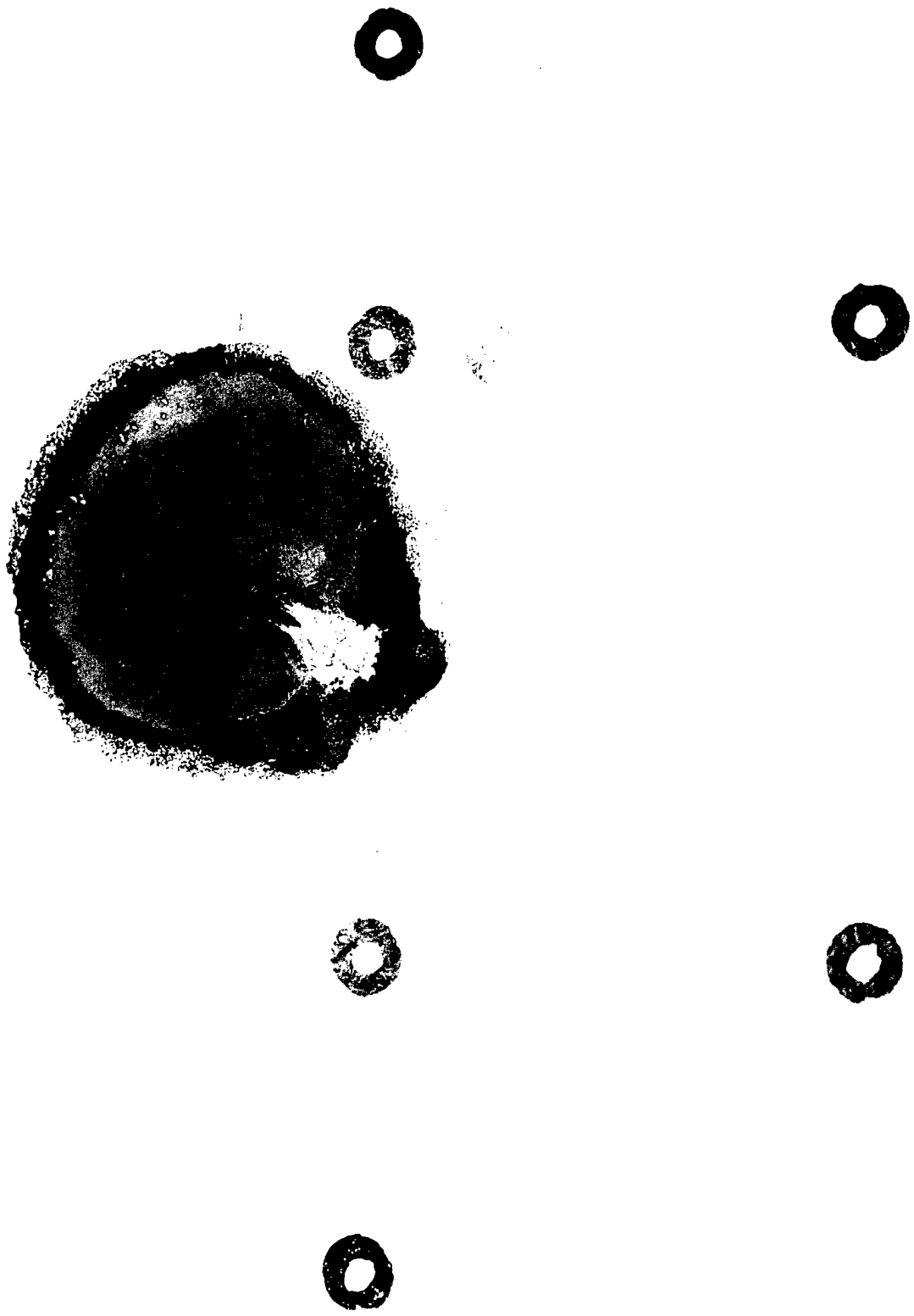

Figure B-8. Resultant Damage Due to Component A to Panel Q-13#2, Close Up View.

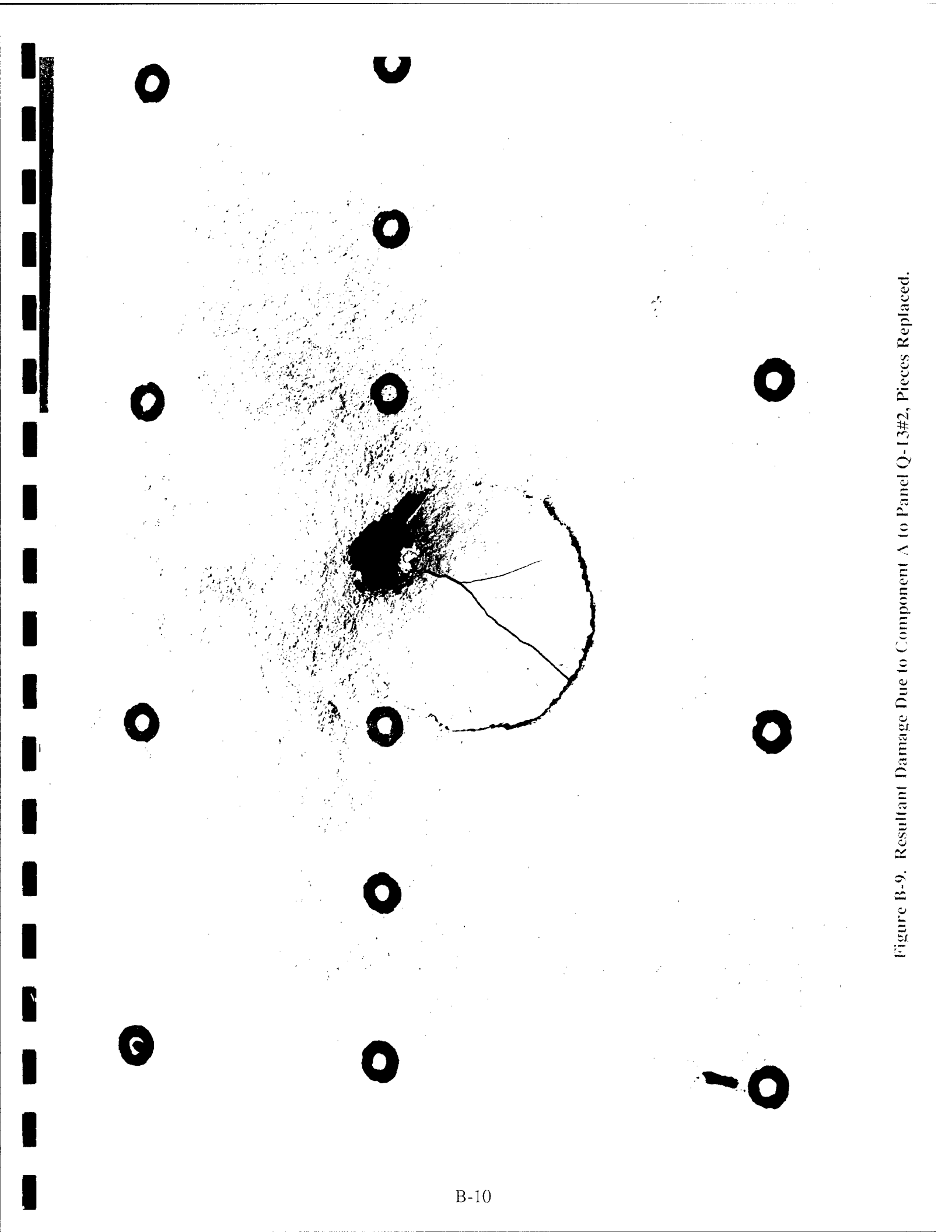
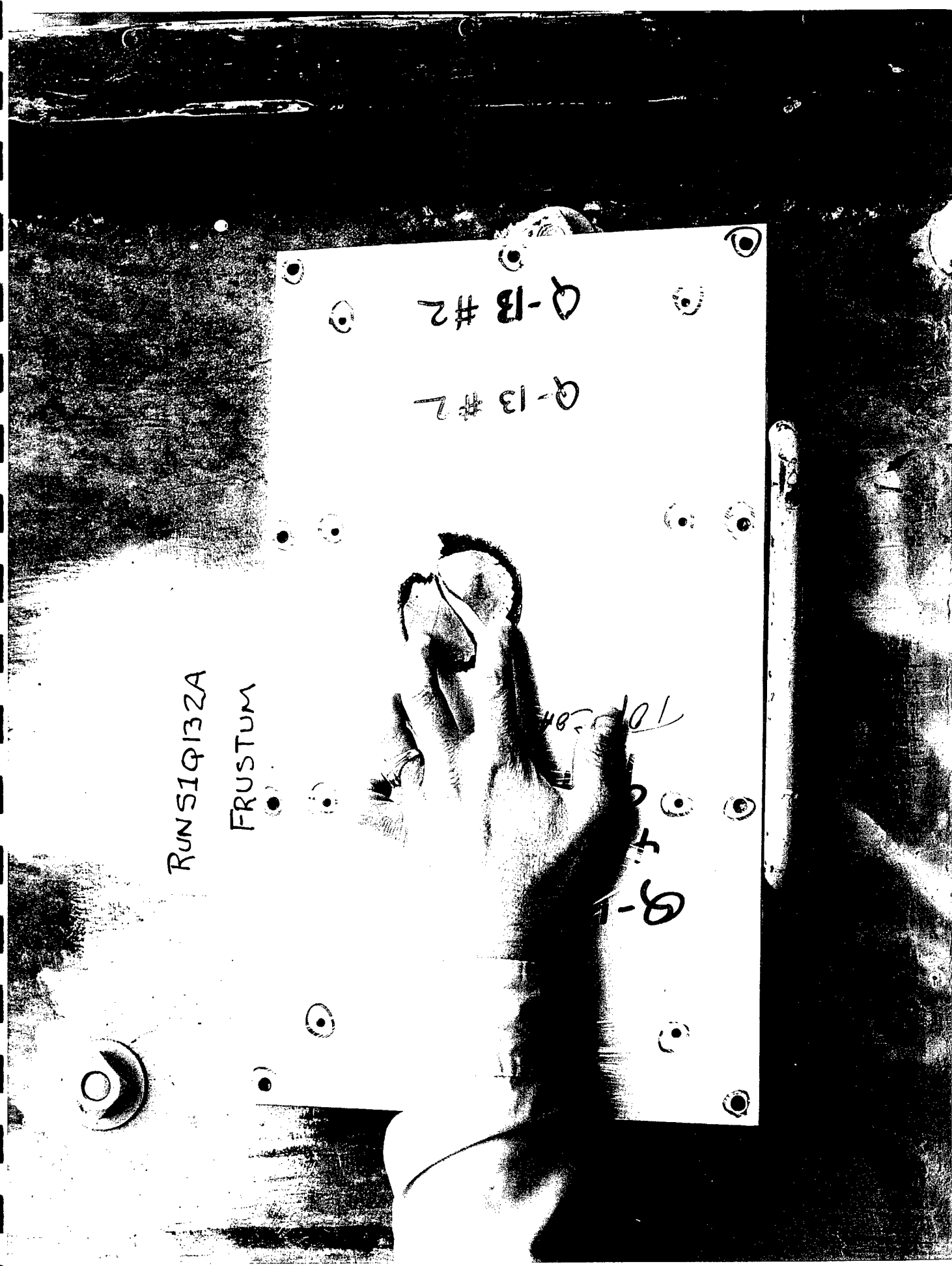

Figure B-9. Resultant Damage Due to Component A to Panel Q-13#2, Pieces Replaced.



Figure B-10. Resultant Damage Due to Component A to Panel Q-13#2. Back View with Pieces.



RUNS1Q132A

FRUSTUM

Q-13 #2

Q-13 #2

Q-13 #2

Q-13 #2

Figure B-11. Resultant Damage Due to Component A to Panel Q-13#2. Back View with Pieces.

RUNSIQ13ZA

FRUSTUM

Q-13 #2
4.33.7
9-29-94
TOP CENTER

Q-13 #2

Q-13 #2

Figure B-12. Resultant Damage Due to Component A to Panel Q-13#2, Back View.

RUN SIG116A
AFT SKIRT

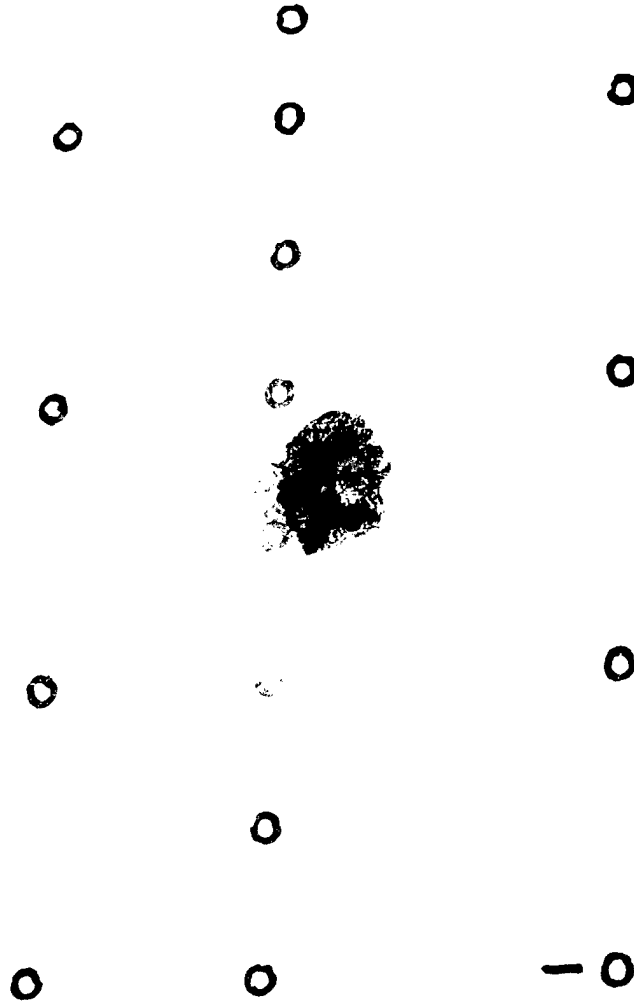

Figure B-13. Resultant Damage Due to Component A to Panel Q-11#6, Front View.

RUN SIQ116A
AFT SKIRT

Q-11#6

TOP
Q11-#6
4.3, 3, 7

Figure B-14. Resultant Damage Due to Component A to Panel Q-11#6, Back View.

RUN 51Q118A

AFT SKIRT

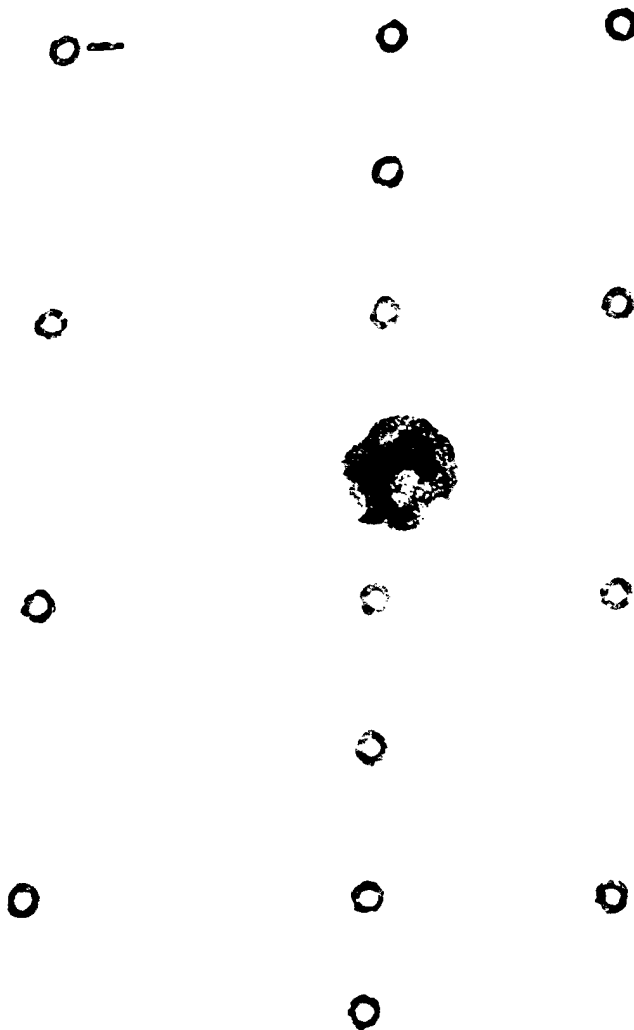

Figure B-15. Resultant Damage Due to Component A to Panel Q-11#8, Front View.

RUN 51Q118A
AFT SKIRT

Q-11-8
E-30-94
TOP COATED

Q-11-8

Figure B-16. Resultant Damage Due to Component A to Panel Q-11#8, Back View.

RUN 51Q119A
AFT SKIRT

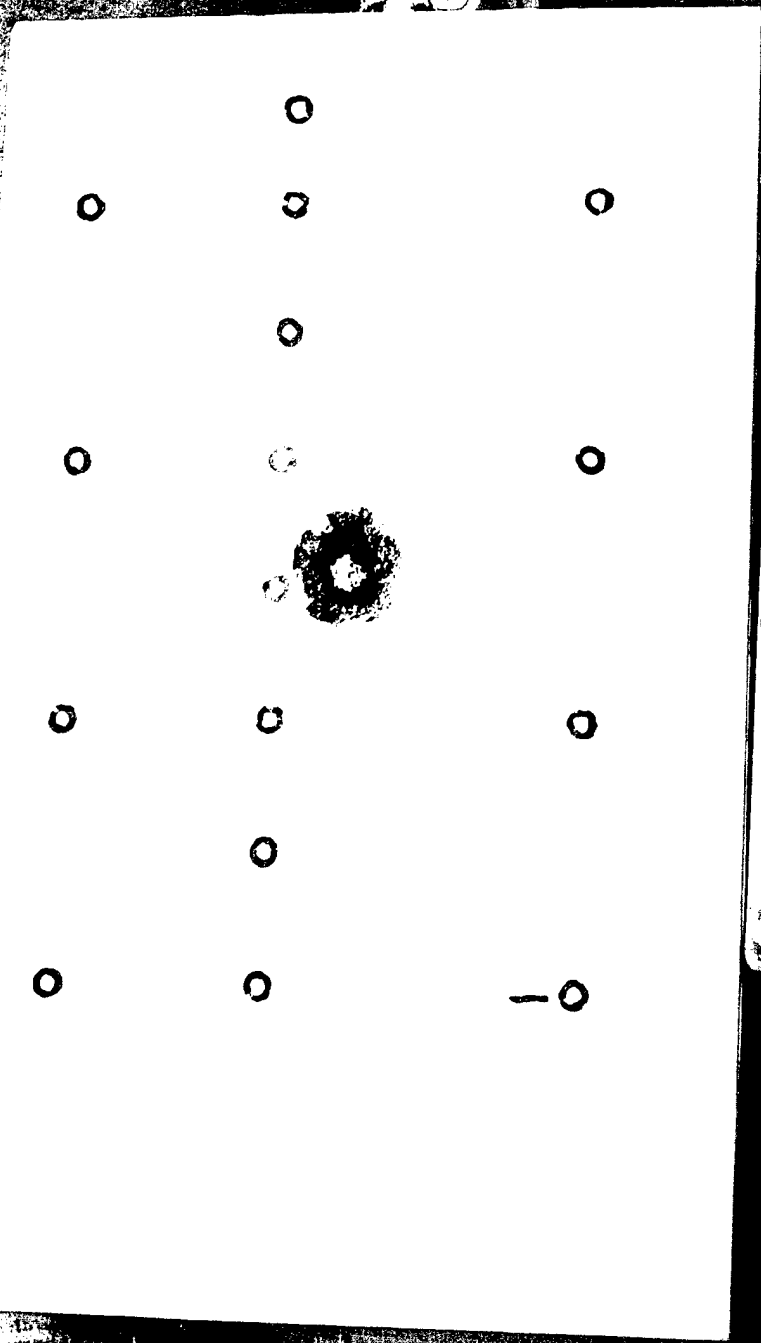
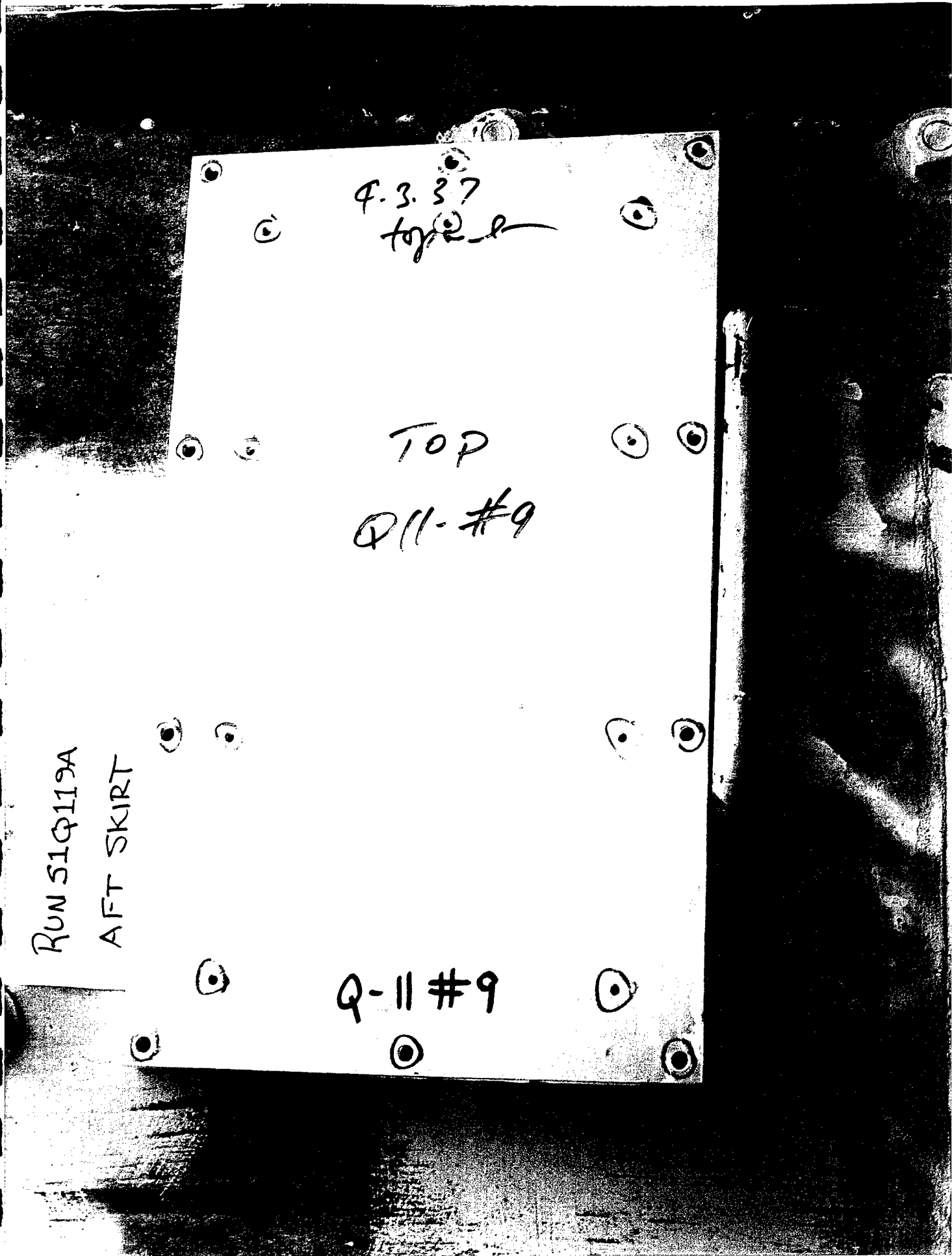

Figure B-17. Resultant Damage Due to Component A to Panel Q-11#9, Front View.



4.3.37
top

TOP
Q11-#9

RUN 51Q119A
AFT SKIRT

Q-11-#9

Figure B-18. Resultant Damage Due to Component A to Panel Q-11#9, Back View.

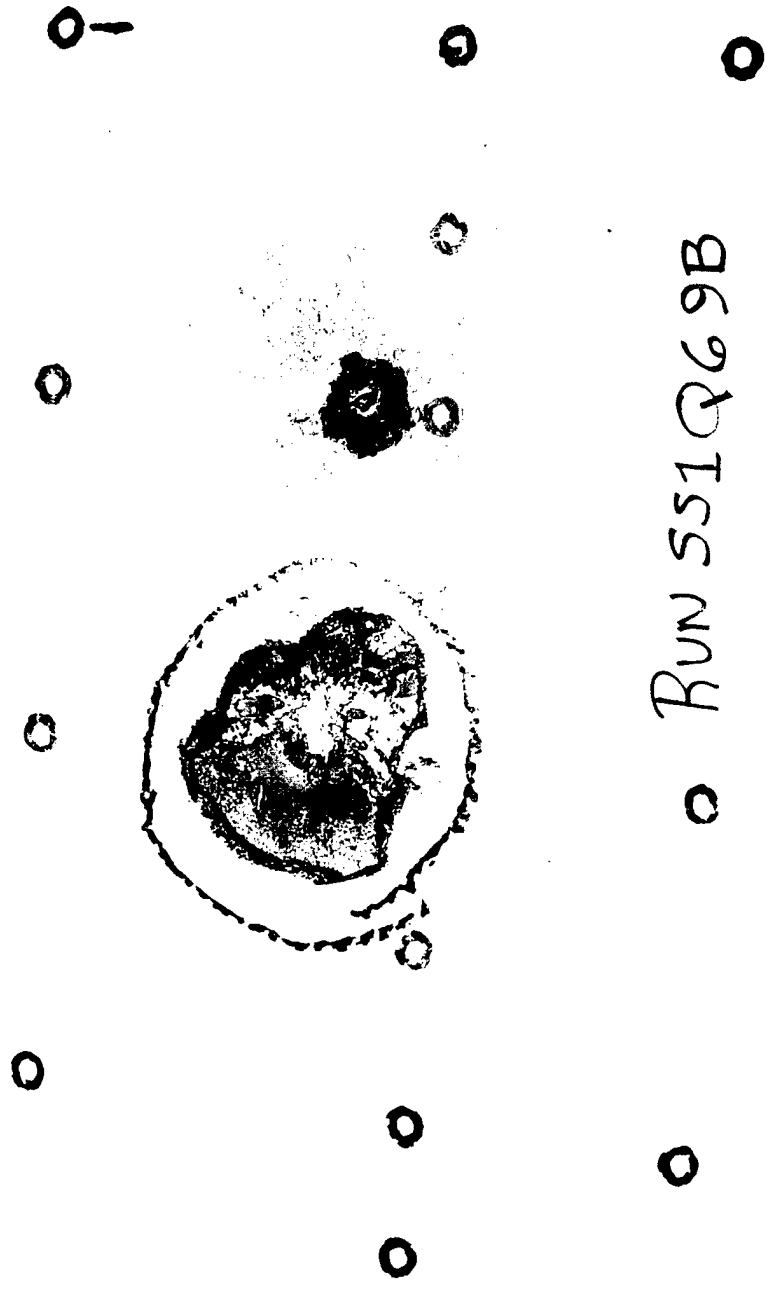

RUN 551 Q69B

FRUSTUM

Figure B-19. Cumulative Damage Due to Components A and B to Panel Q-6#9, Front View.

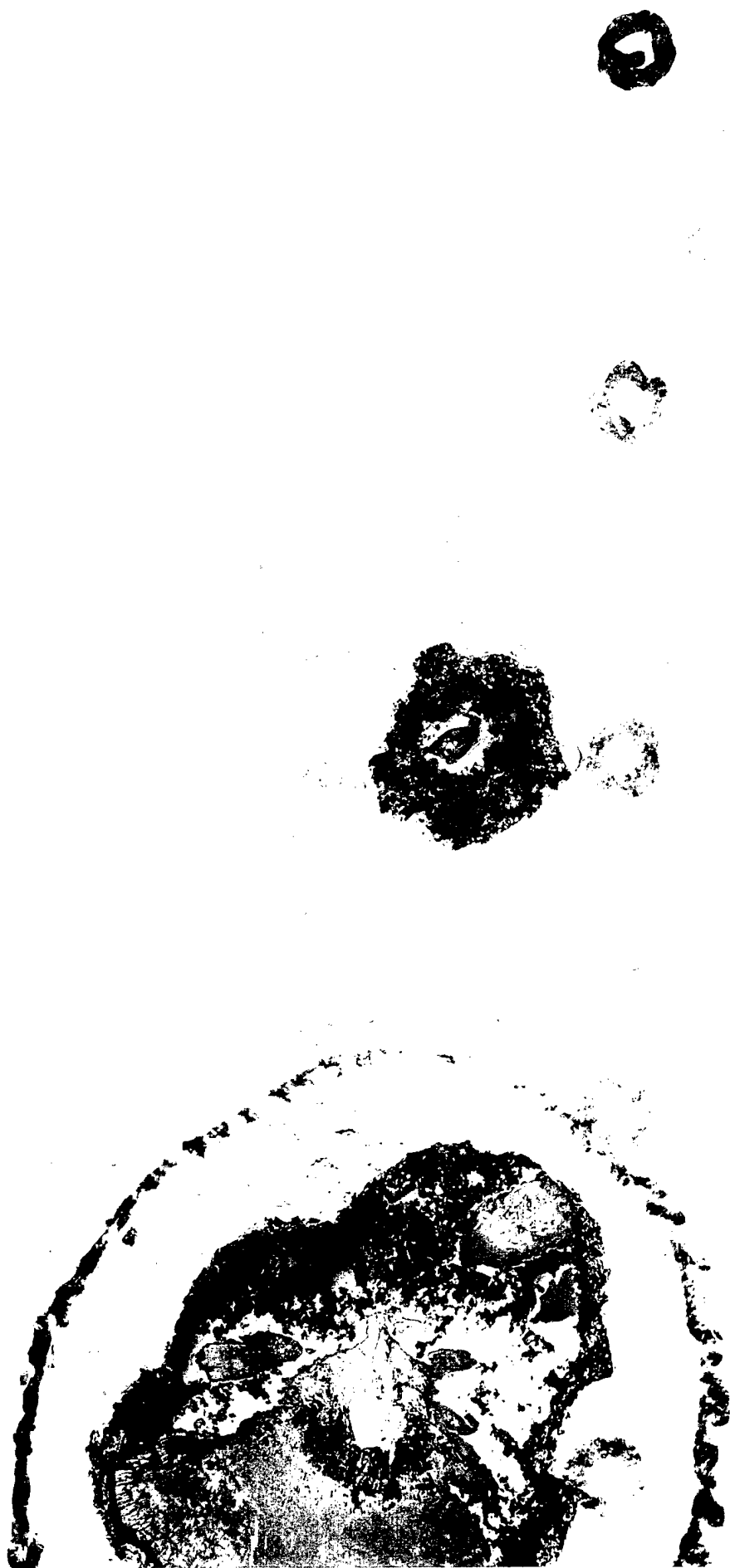

Figure B-20. Cumulative Damage Due to Components A and B to Panel Q-6#9, Close Up View.

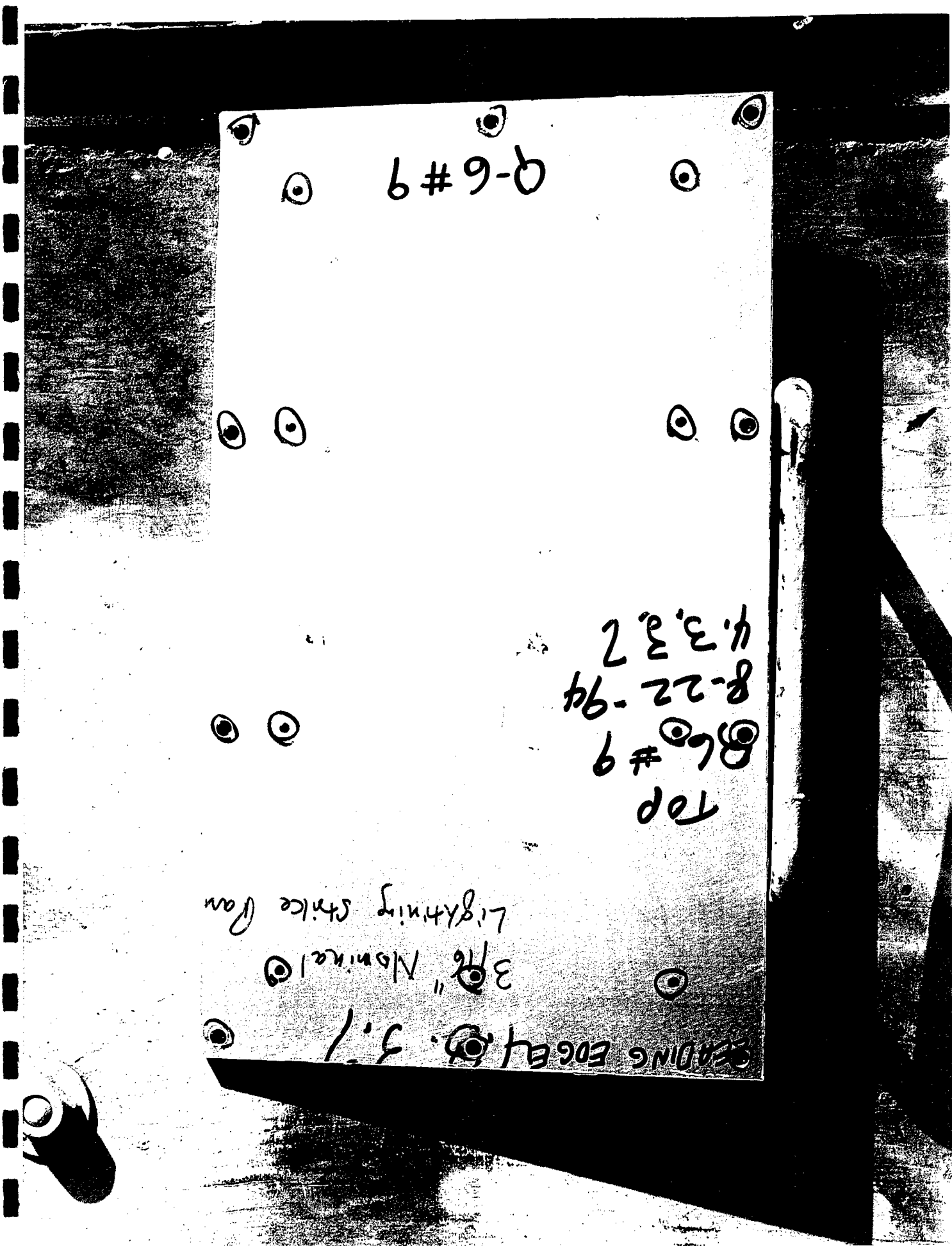

Figure B-21. Cumulative Damage Due to Components A and B to Panel Q-6#9, Back View.

RUN SI Q610B

FRUSTUM

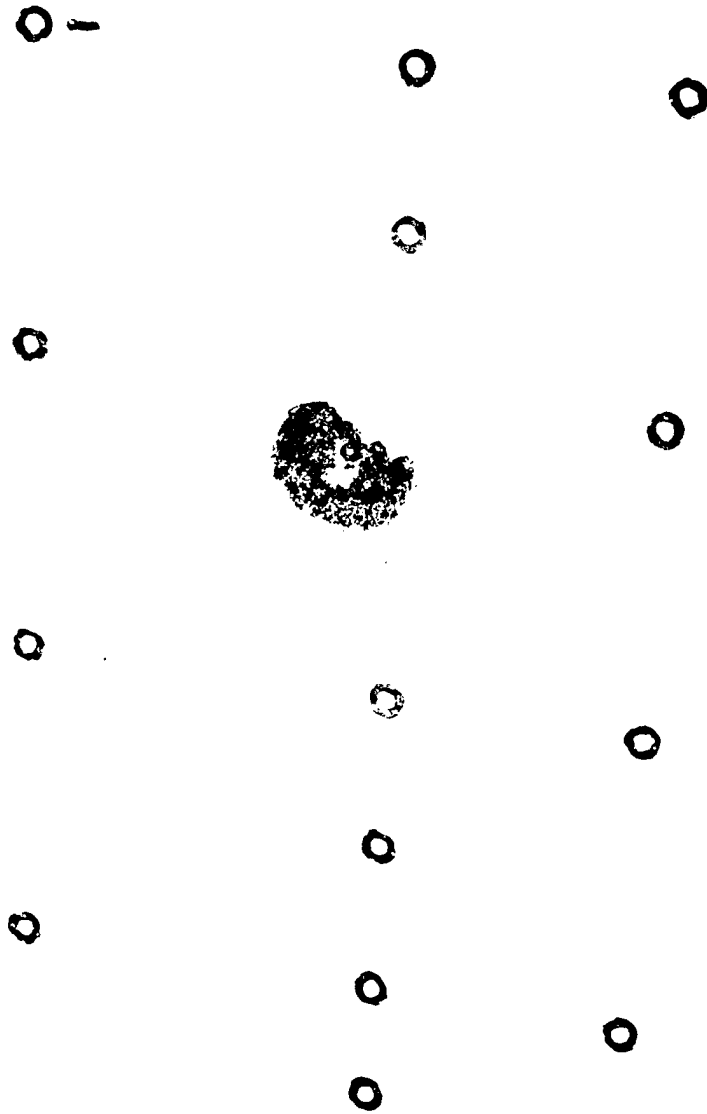

Figure B-22. Cumulative Damage Due to Components A and B to Panel Q-6#10, Front View.

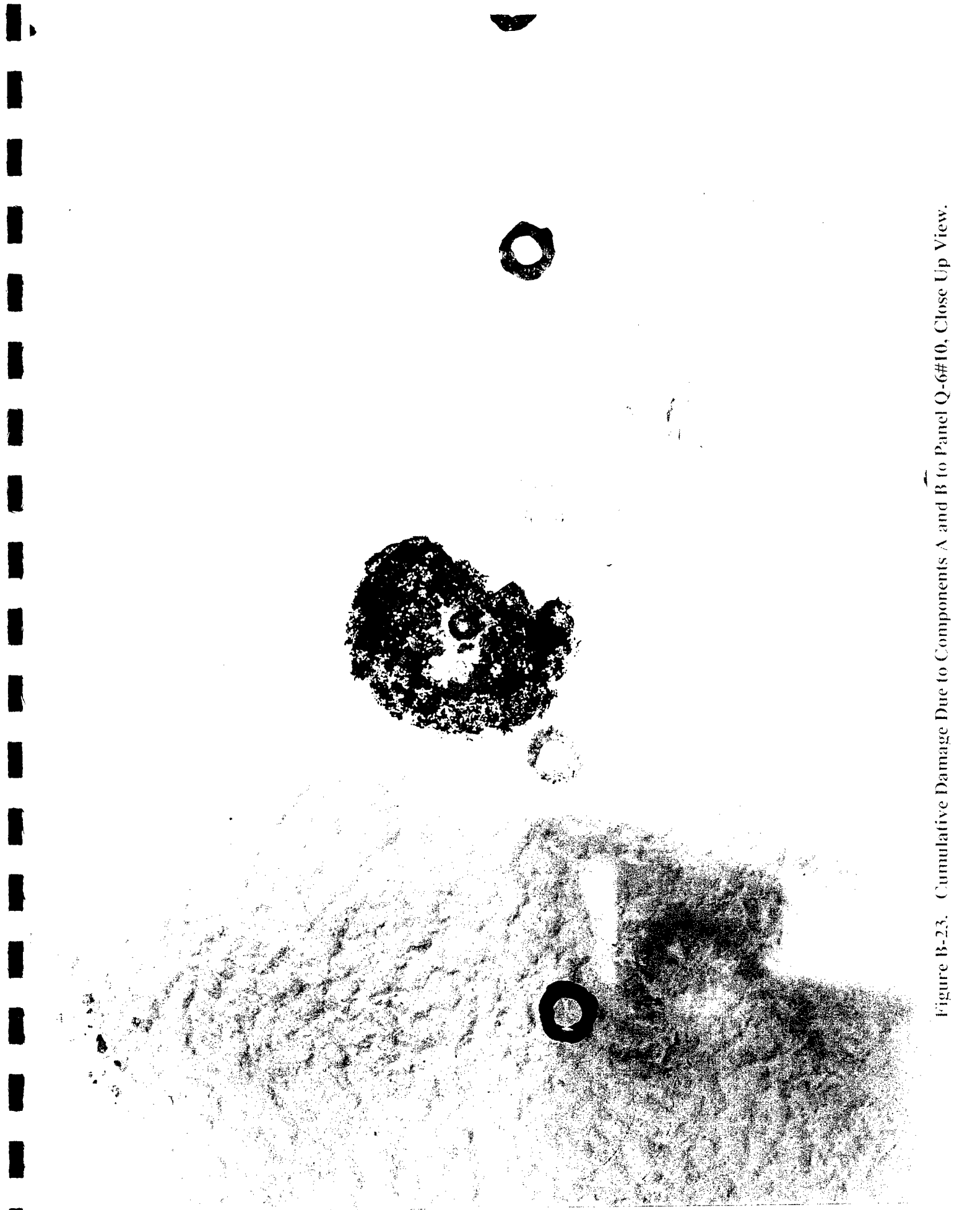
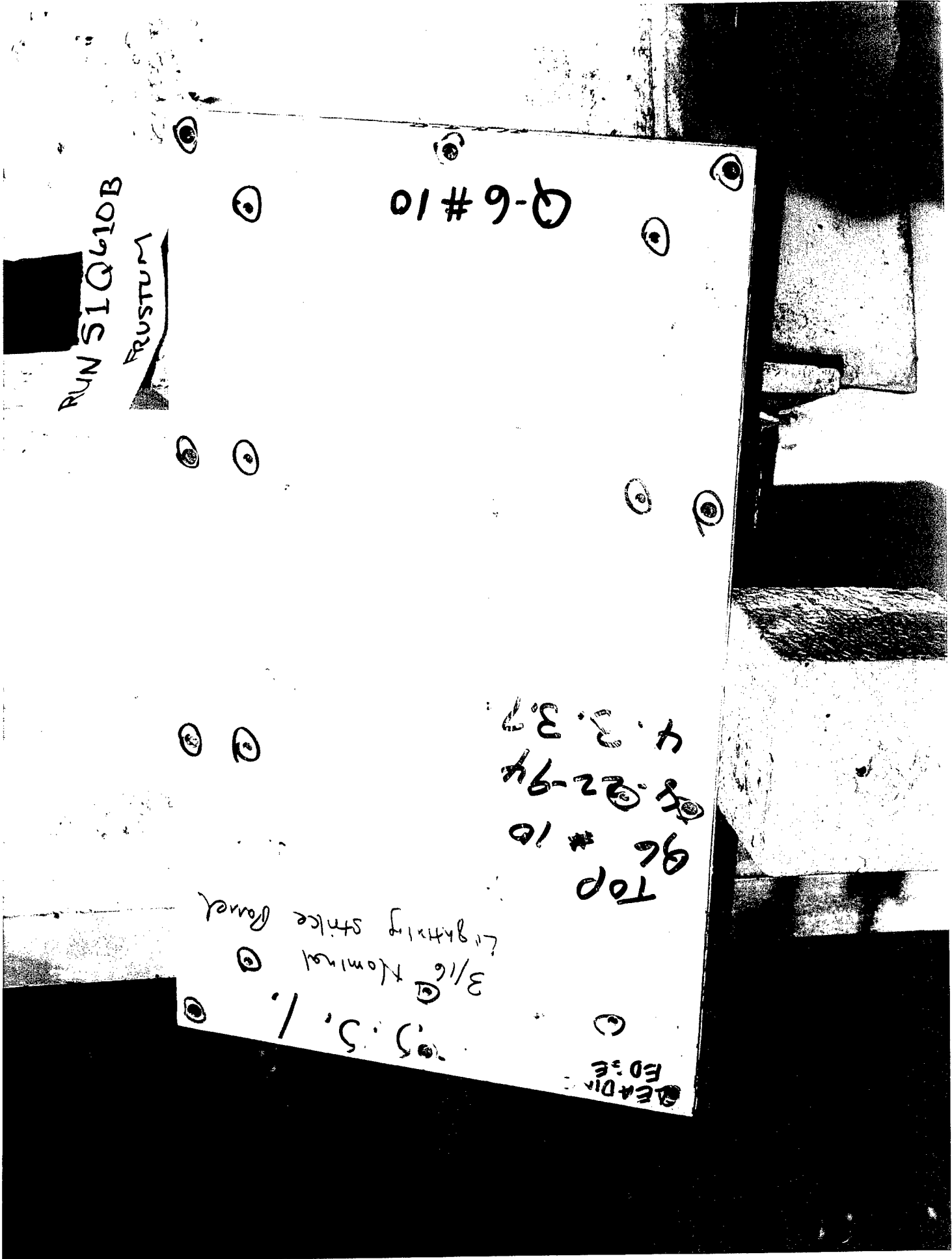

Figure B-23. Cumulative Damage Due to Components A and B to Panel Q-6#10, Close Up View.



RUN 51 Q610B

FRUSTUM

Q-6 #10

TOP #10
96-22-94
4.3.37

3/16 Nominal
Lightning strike Panel

5.5. /

LEADING
EDGE

Figure B-24. Cumulative Damage Due to Components A and B to Panel Q-6#10, Back View.

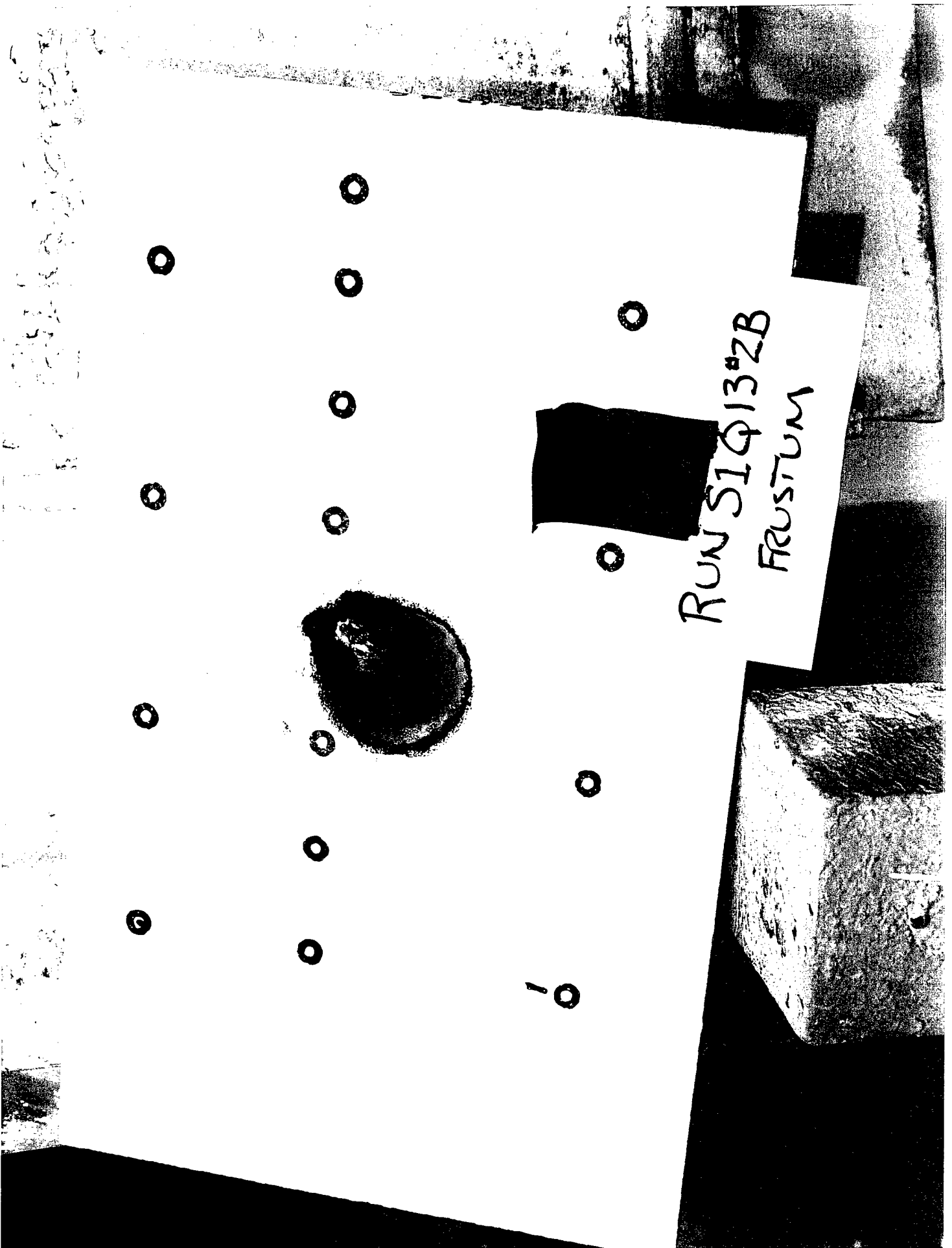

RUN S1Q13#2B
FRUSTUM

Figure B-25. Cumulative Damage Due to Components A and B to Panel Q-13#2, Front View.

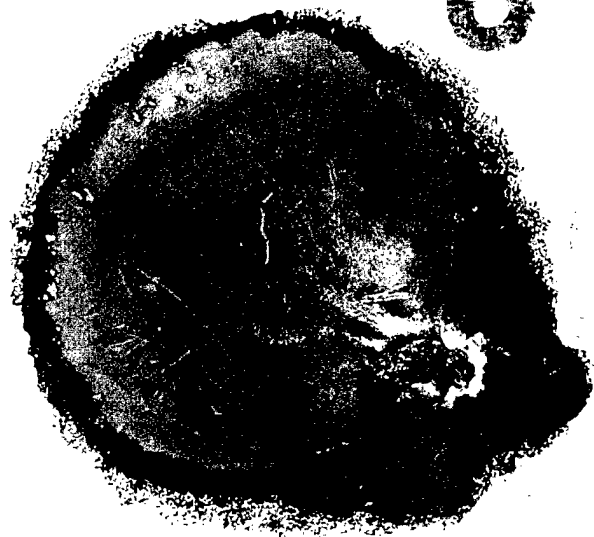

Figure B-26. Cumulative Damage Due to Components A and B to Panel Q-13#2, Close Up View.

RUN S1 Q13#2B
FRUSTUM

Q-13 # 2

4.33.7

9-29-94

TOP COATED

Q-13 #2

Q-13 #2

Figure B-27. Cumulative Damage Due to Components A and B to Panel Q-13#2. Back View.

RUNSIQ116B
AFT SKIRT

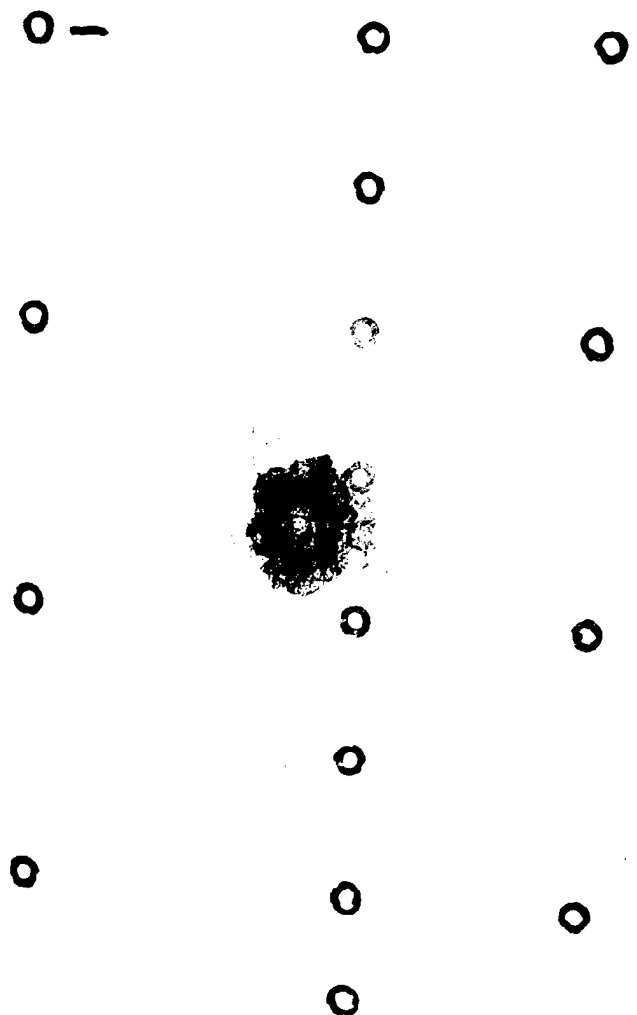

Figure B-28. Cumulative Damage Due to Components A and B to Panel Q-11#6, Front View.

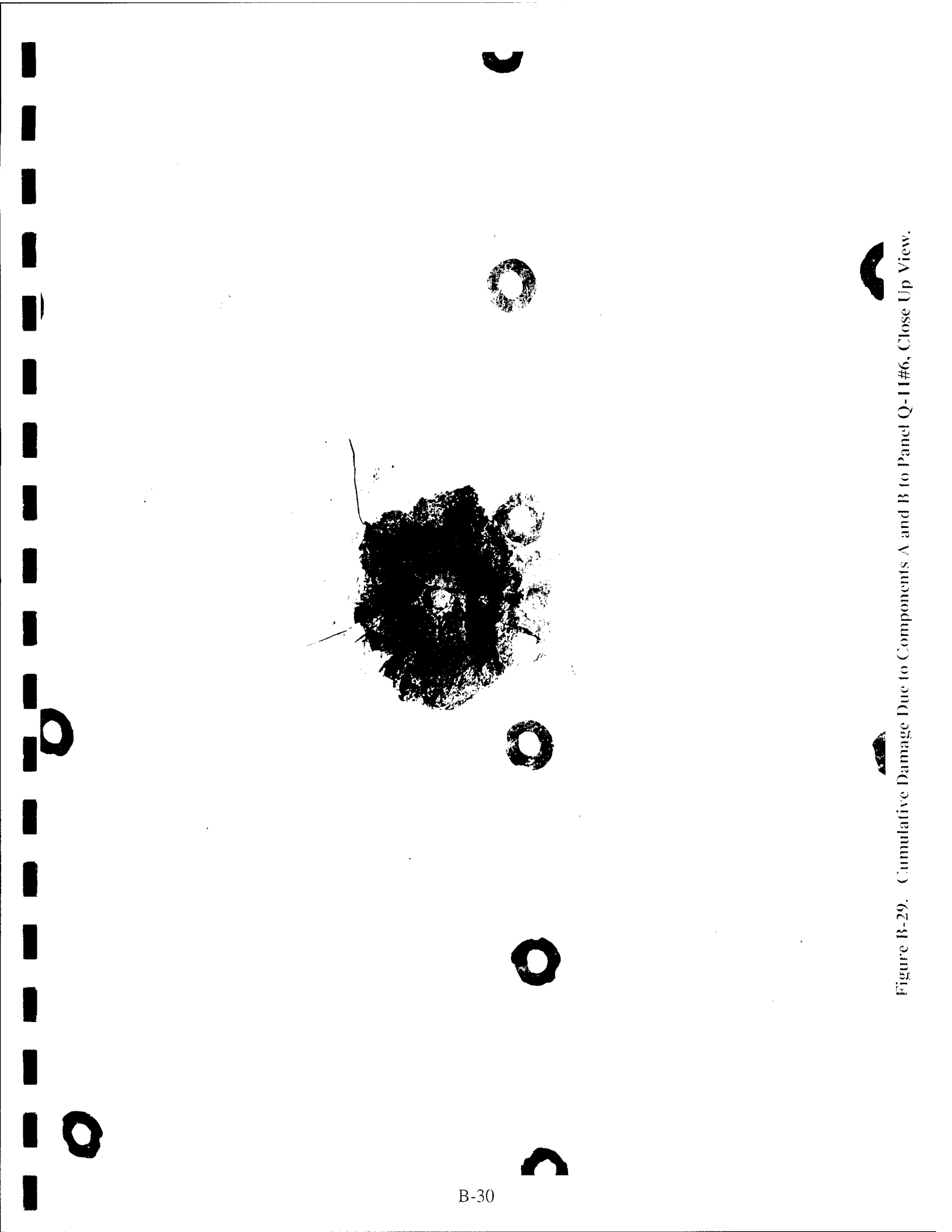
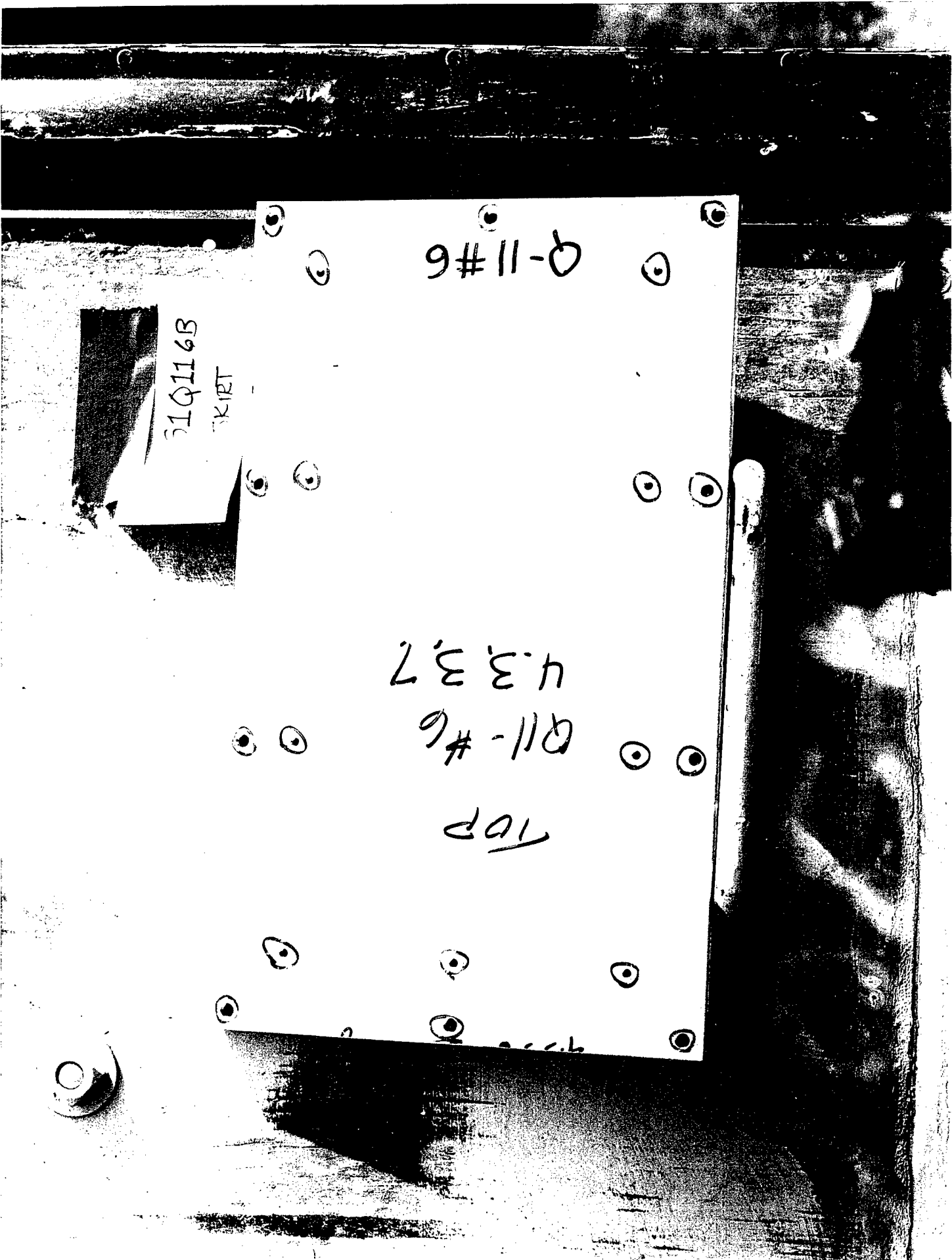

Figure B-29. Cumulative Damage Due to Components A and B to Panel Q-II#6, Close Up View.



Q116B
TKIRT

Q-11-6

4.3.37

Q-11-6

TOP

Figure B-30. Cumulative Damage Due to Components A and B to Panel Q-11#6, Back View.

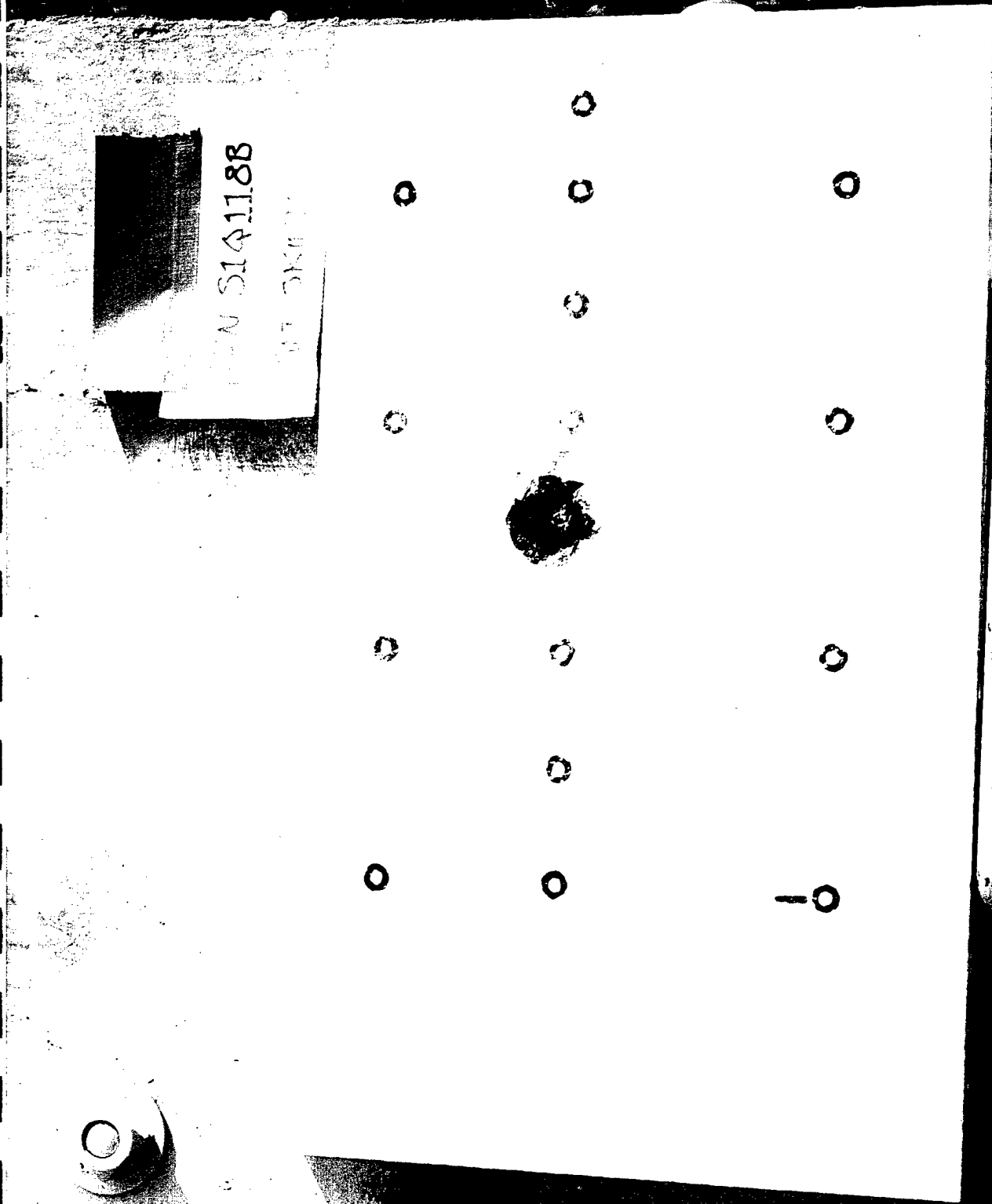

Figure B-31. Cumulative Damage Due to Components A and B to Panel Q-11#8, Front View.

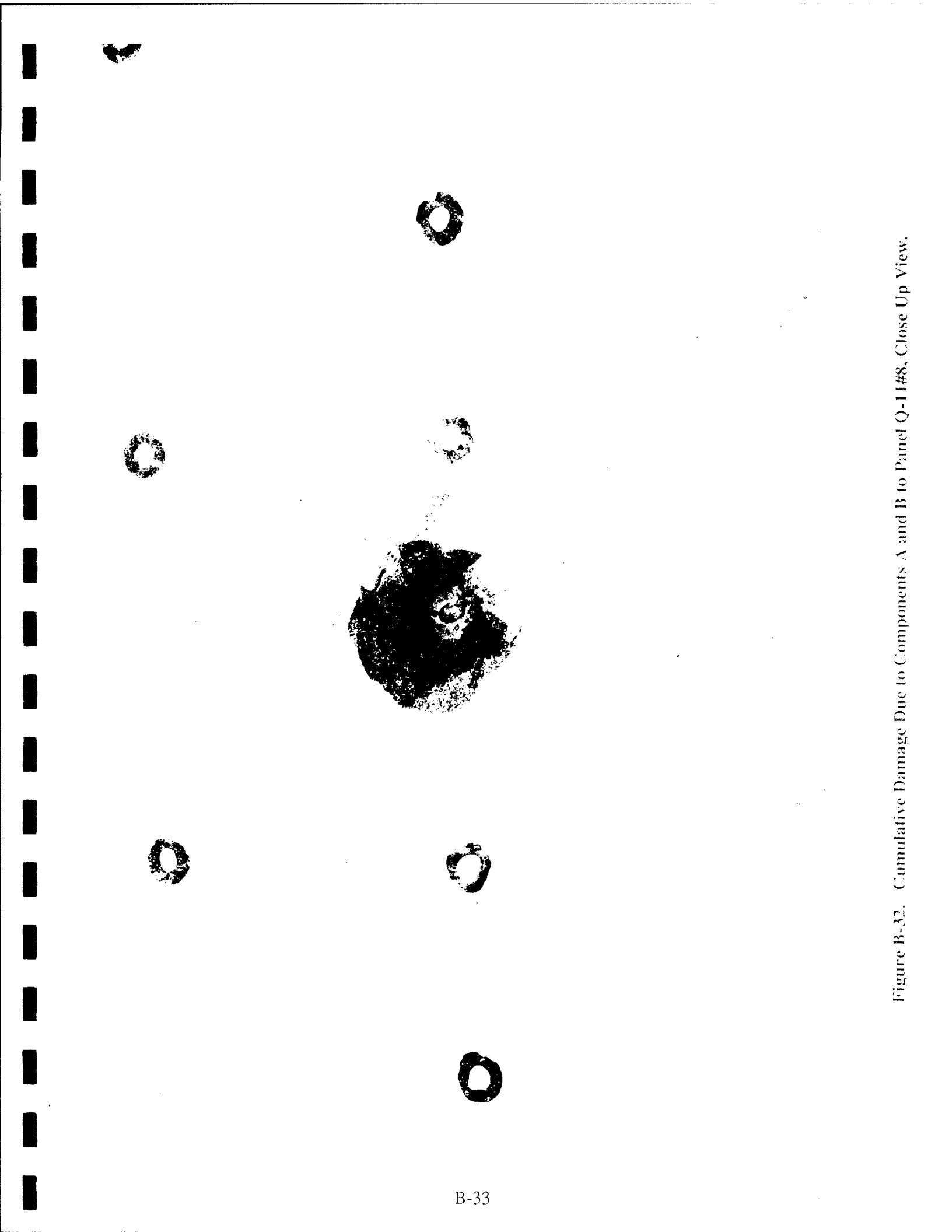

Figure B-32. Cumulative Damage Due to Components A and B to Panel Q-11#8, Close Up View.

UN SIG 118B

ART SKIRT

Q-11 # 8

8-30-94

4337

TOP COATED

Q-11 # 8

Figure B-33. Cumulative Damage Due to Components A and B to Panel Q-1 #8, Back View.

RUN SI Q11 9B
AFT SKIRT

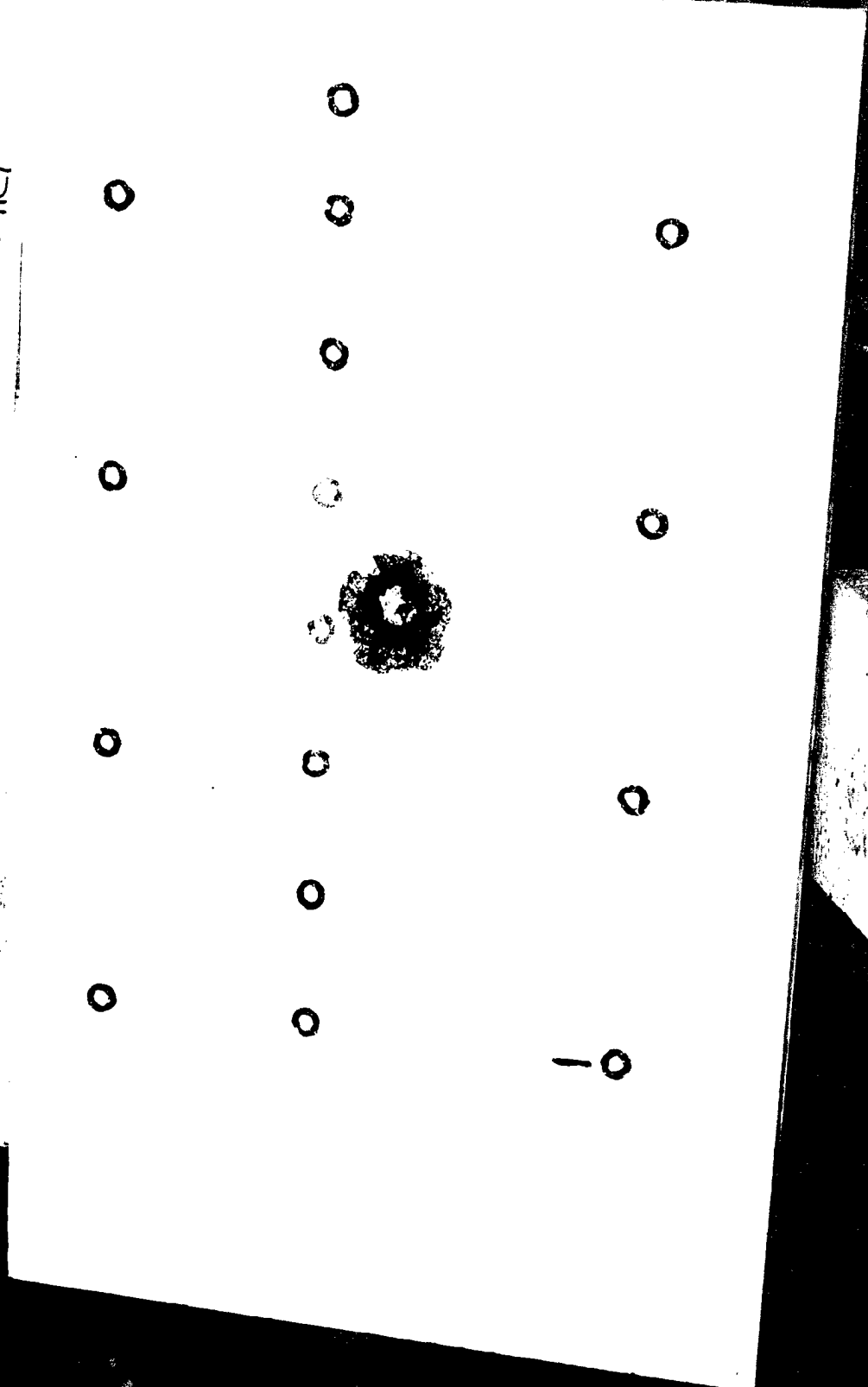

Figure B-34. Cumulative Damage Due to Components A and B to Panel Q-11#9, Front View.

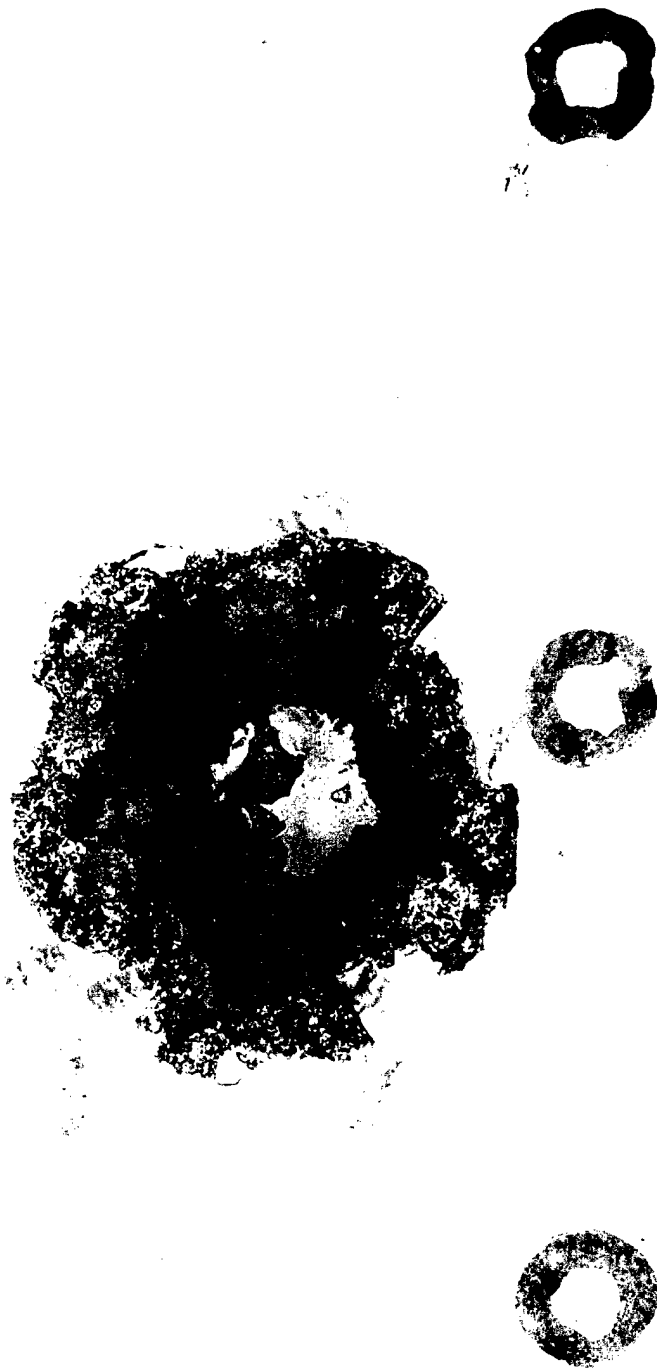
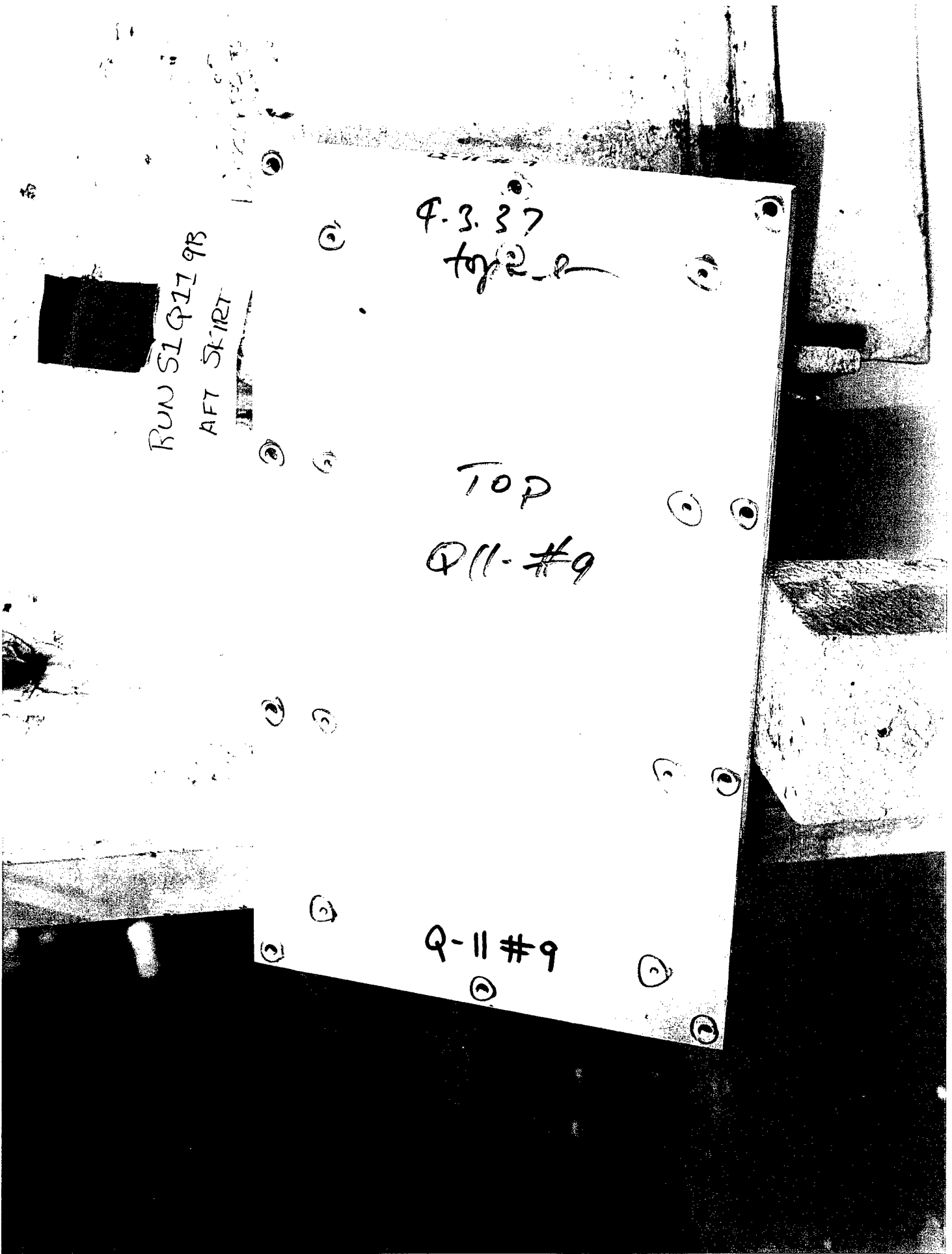

Figure B-35. Cumulative Damage Due to Components A and B to Panel Q-11#9, Close Up View.



RUN S1 Q11 9B
AFT SKIRT

Q-3.37
top

TOP
Q11-#9

Q-11#9

Figure B-36. Cumulative Damage Due to Components A and B to Panel Q-11#9, Back View.



Figure B-37. Cumulative Damage Due to Components A, B, and C to Panel Q-6#9, Front View.

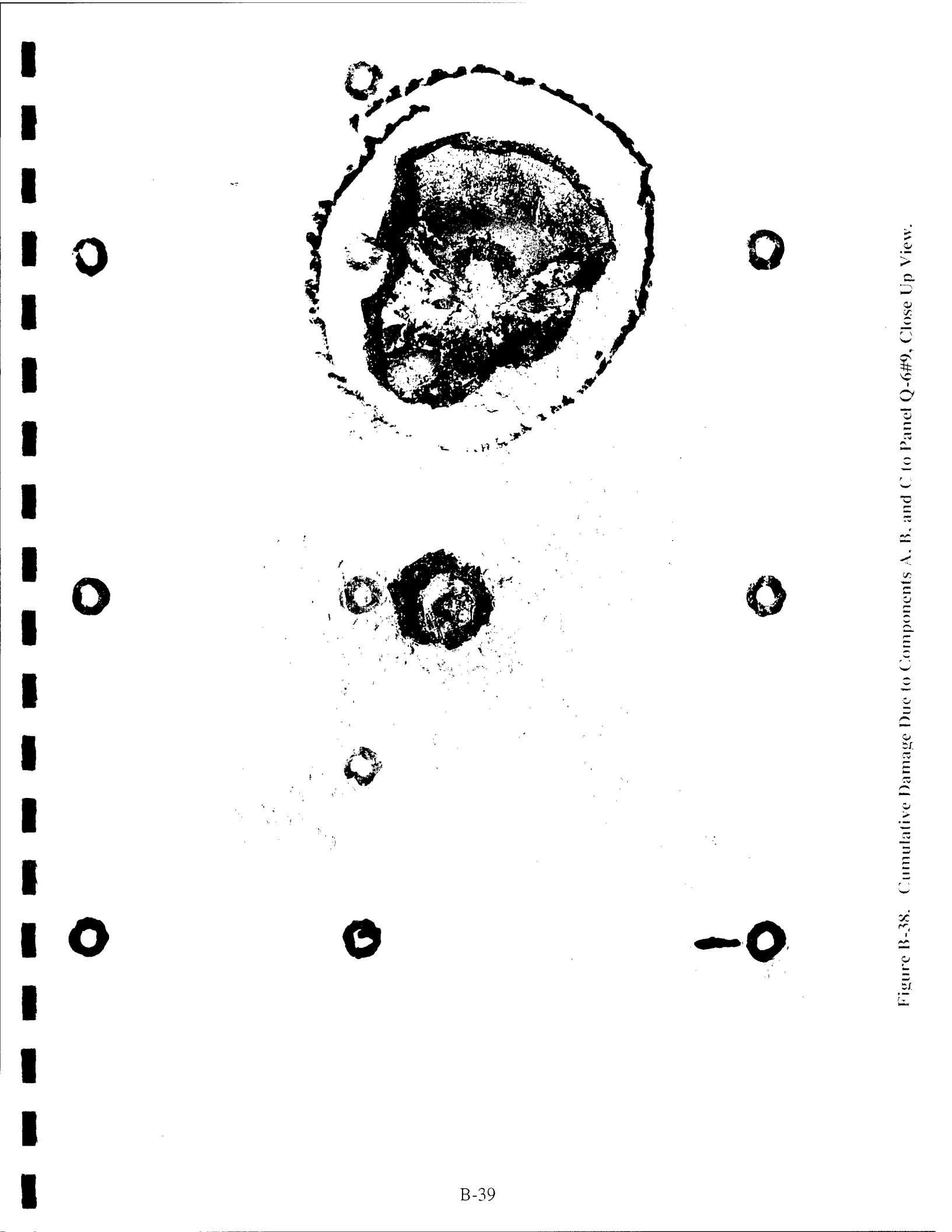

Figure B-38. Cumulative Damage Due to Components A, B, and C to Panel Q-6#9, Close Up View.

HIGH VOLTAGE

LEADING EDGE 3.7

3 1/16" Nominal
Lightning strike Pan

RUN 552Q69C
FRUSTUM

TOP
B6 #9
8-22-94
4.3.3.2

Q-6 #9

Figure B-39. Cumulative Damage Due to Components A, B, and C to Panel Q-6#9, Back View.

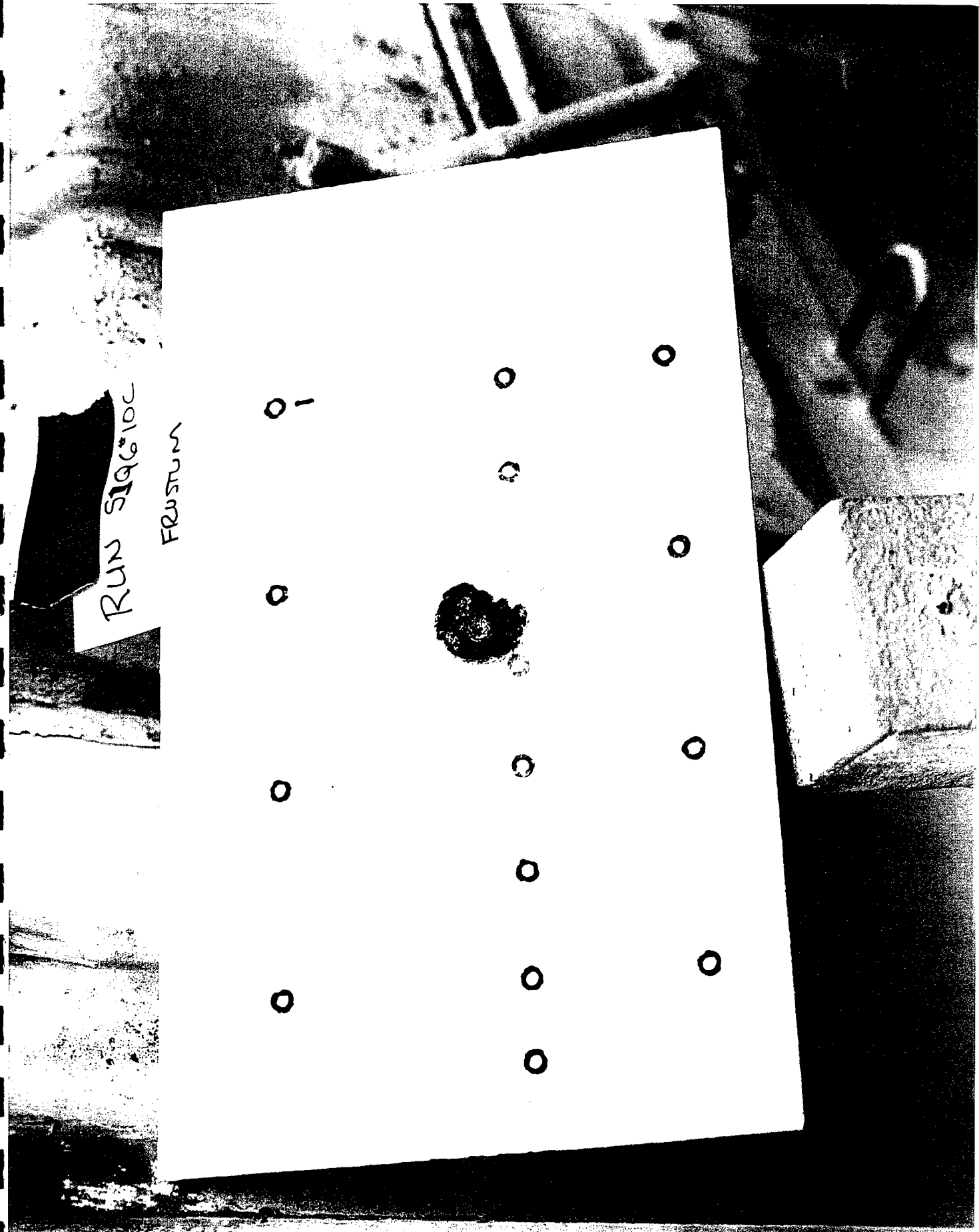

Figure B-40. Cumulative Damage Due to Components A, B, and C to Panel Q-6#10, Front View.

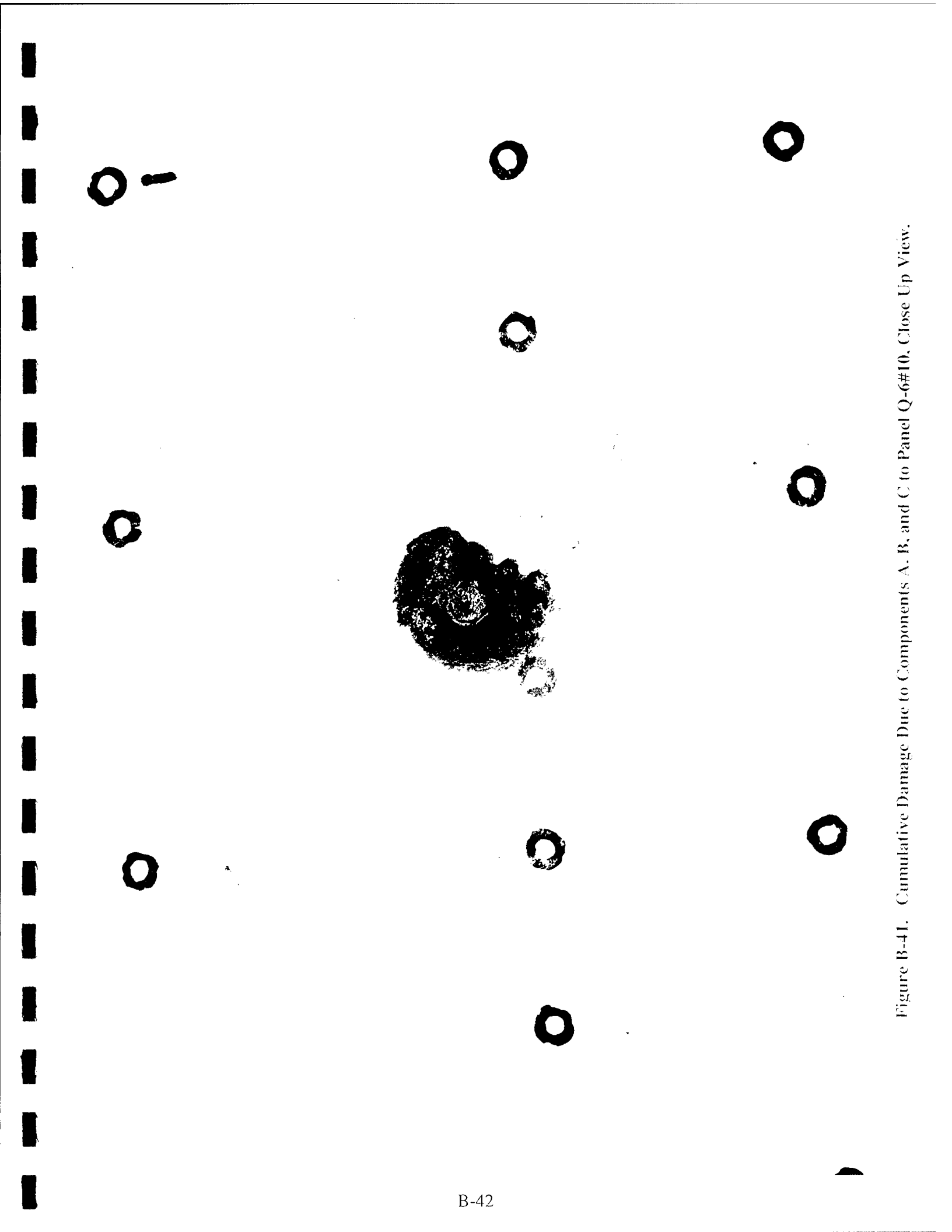

Figure B-41. Cumulative Damage Due to Components A, B, and C to Panel Q-6#10, Close Up View.

WIN Q-13#2

FRUSTUM

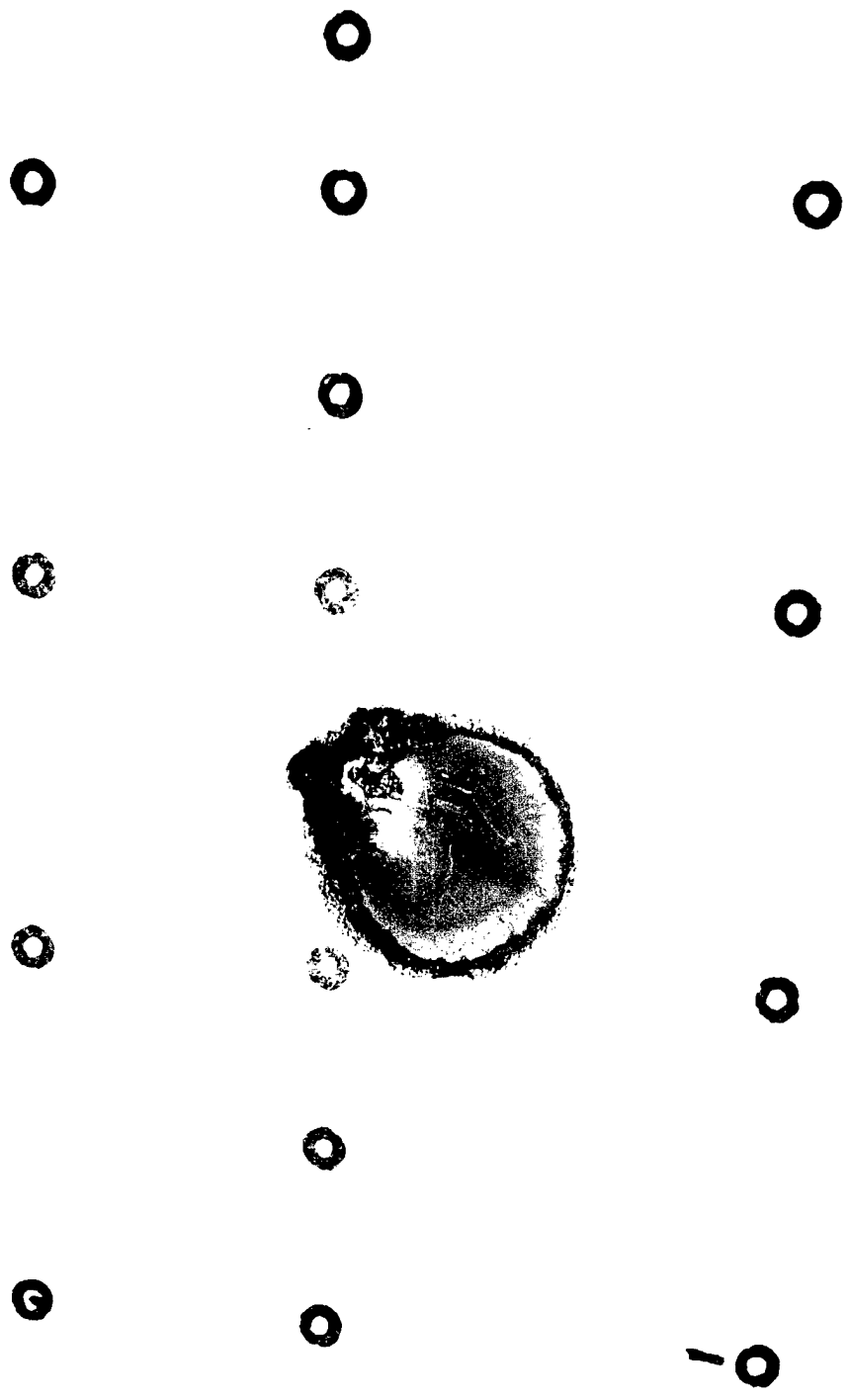

Figure B-43. Cumulative Damage Due to Components A, B, and C to Panel Q-13#2, Front View.

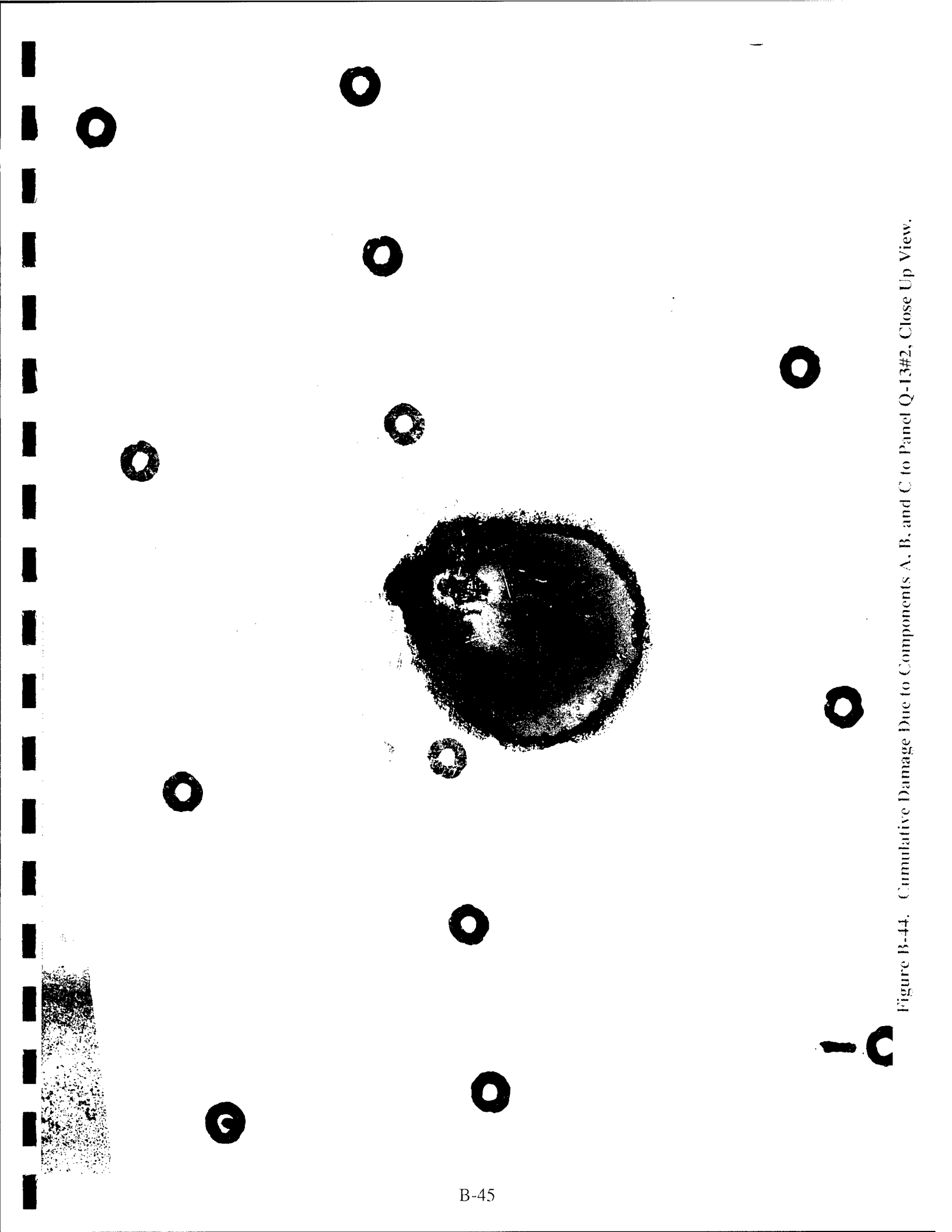

Figure B-44. Cumulative Damage Due to Components A, B, and C to Panel Q-13#2, Close Up View.

Q-13 # 2

4.33.7

Q-29-94

TOP COATED

Q-13 # 2

Q-13 # 2

Figure B-45. Cumulative Damage Due to Components A, B, and C to Panel Q-13#2, Back View.

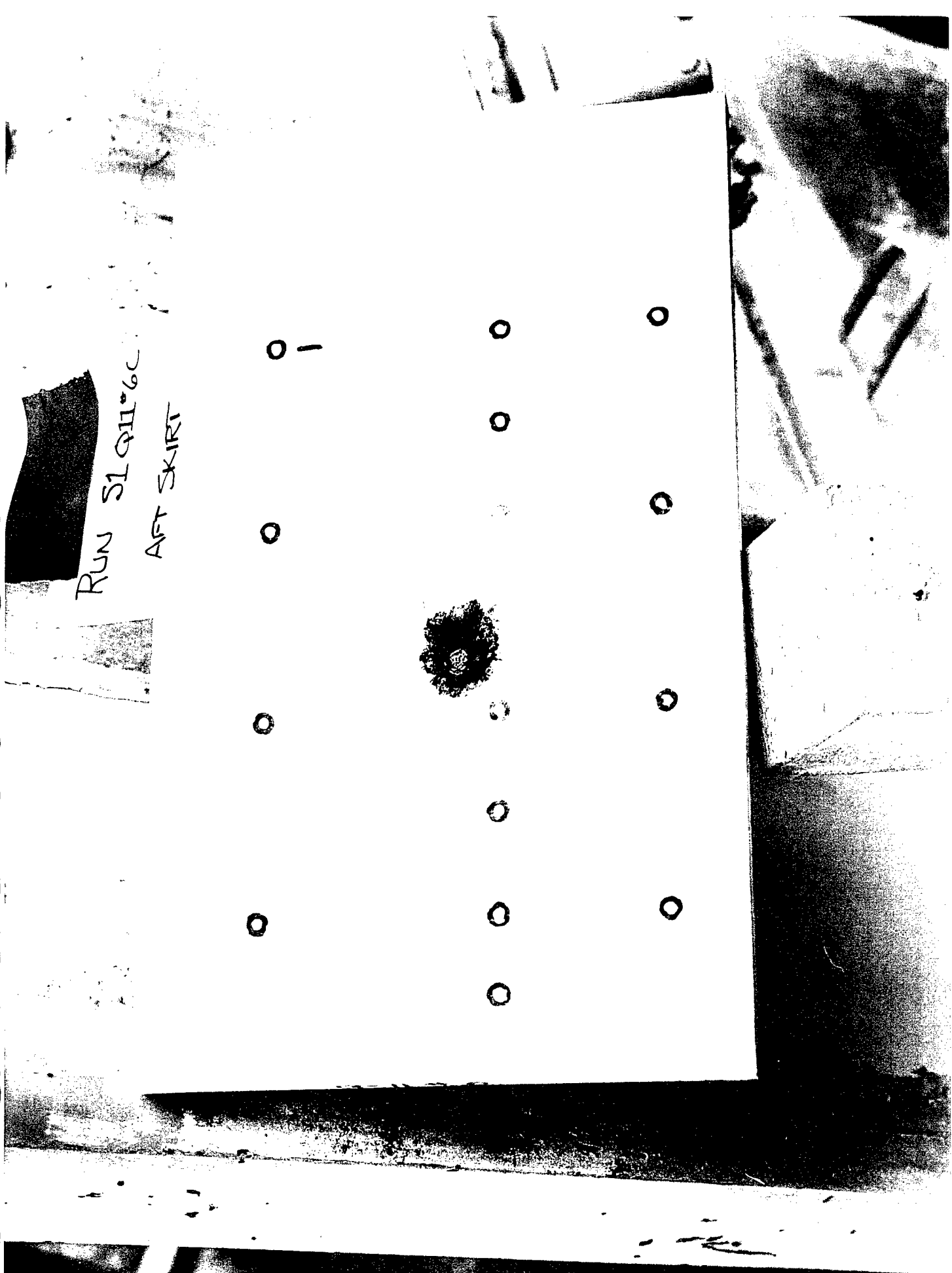

RUN SL Q11-6C
AFT SKIRT

Figure B-46. Cumulative Damage Due to Components A, B, and C to Panel Q-11#6, Front View.

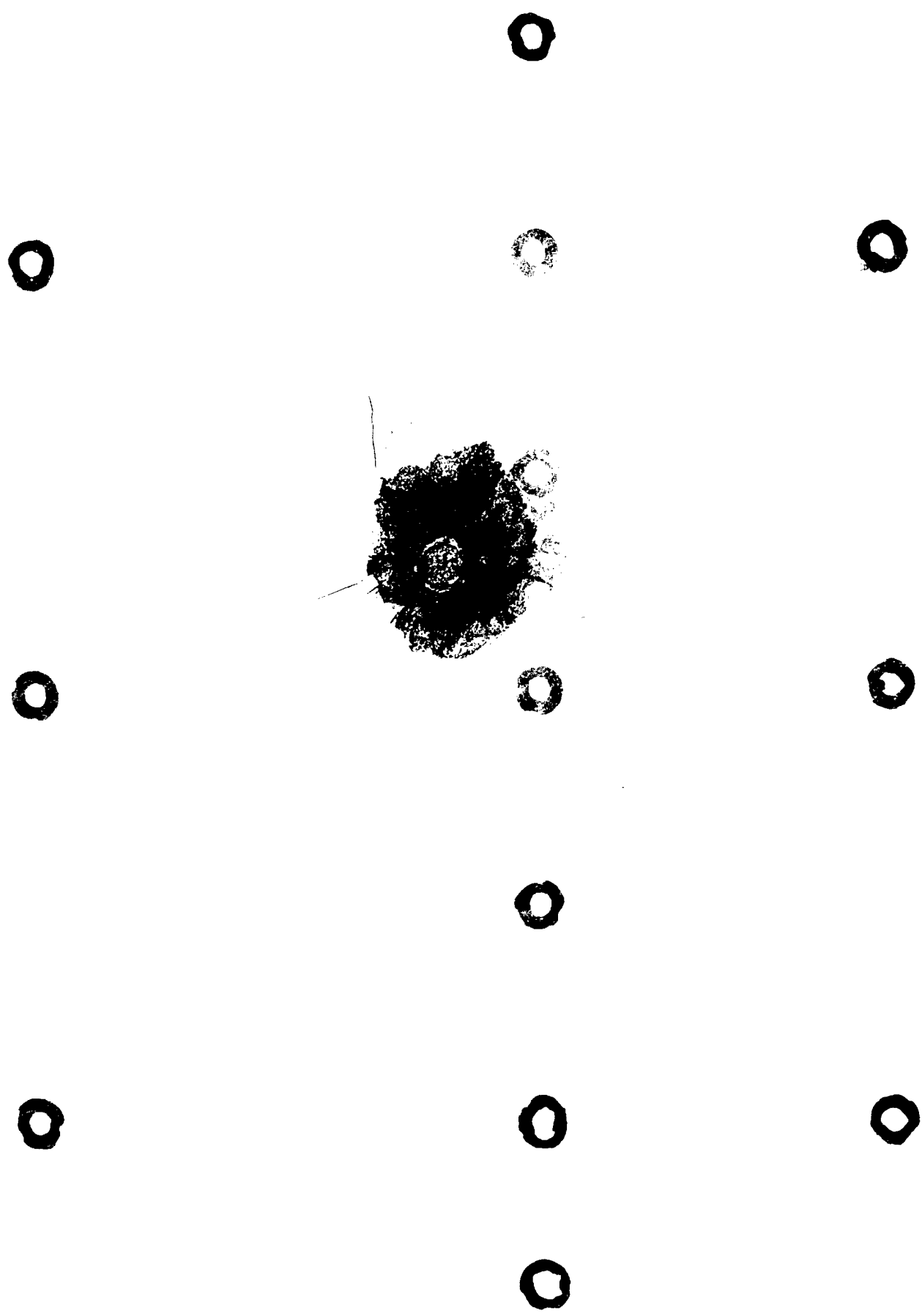

Figure B-47. Cumulative Damage Due to Components A, B, and C to Panel Q-11#6, Close Up View.



Figure B-48. Cumulative Damage Due to Components A, B, and C to Panel Q-1#6, Back View.

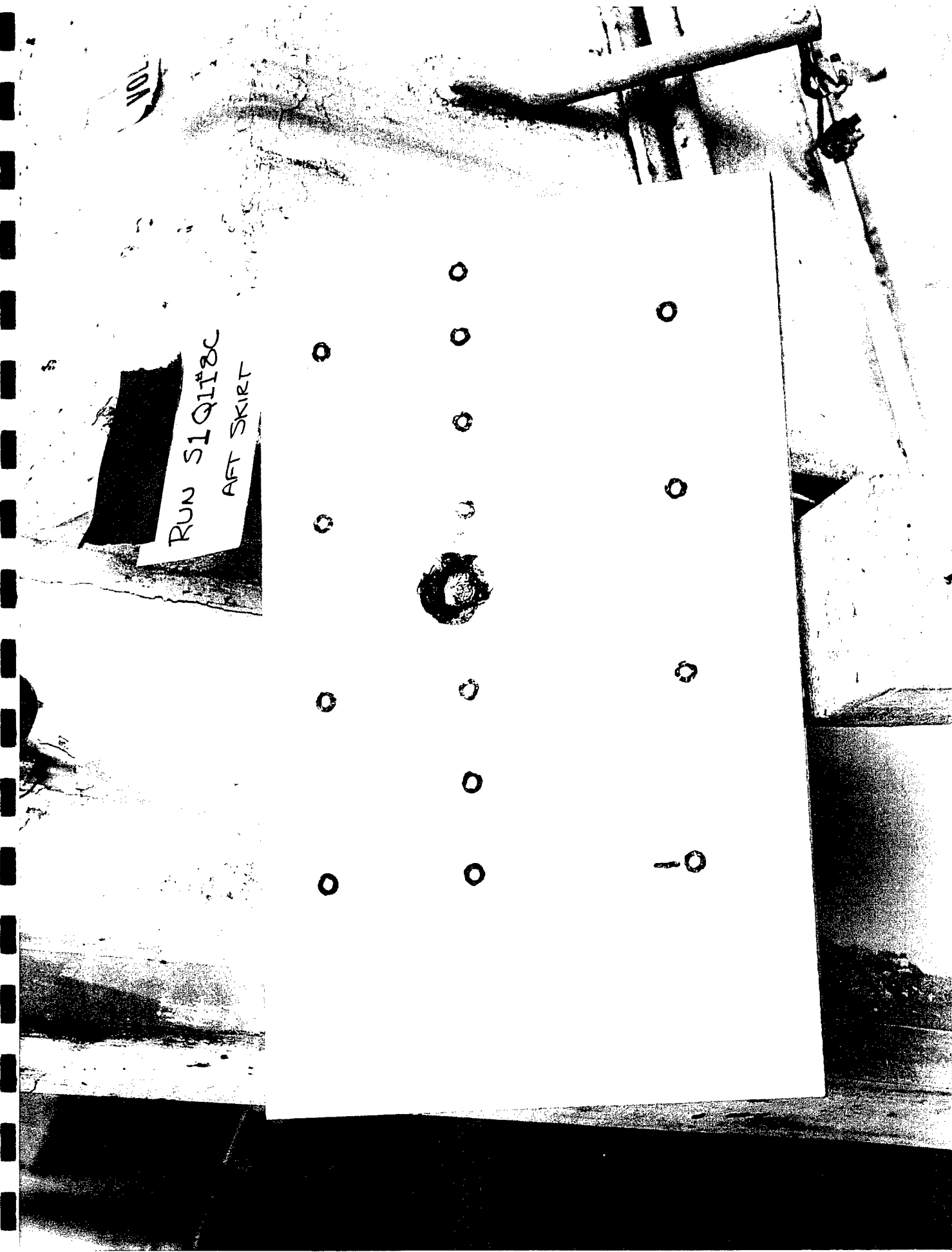

Figure B-49. Cumulative Damage Due to Components A, B, and C to Panel Q-11#8, Front View.

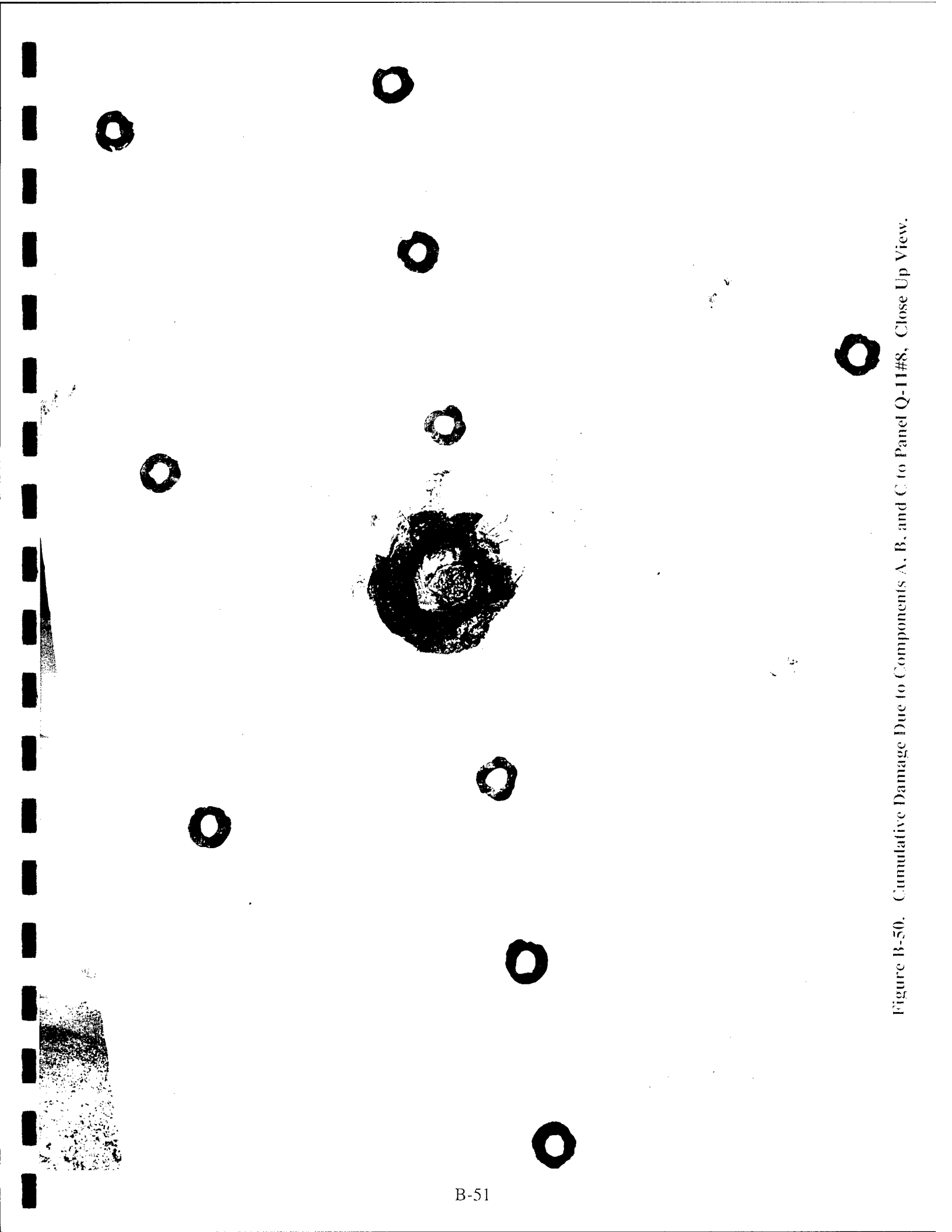

Figure B-50. Cumulative Damage Due to Components A, B, and C to Panel Q-11#8, Close Up View.

1001
RUN S1 Q11#8
AFT SKIRT

Q-11 #8
8-30-94
1337
TOP COATED

Q-11 #8

Figure B-51. Cumulative Damage Due to Components A, B, and C to Panel Q-11#8. Back View.

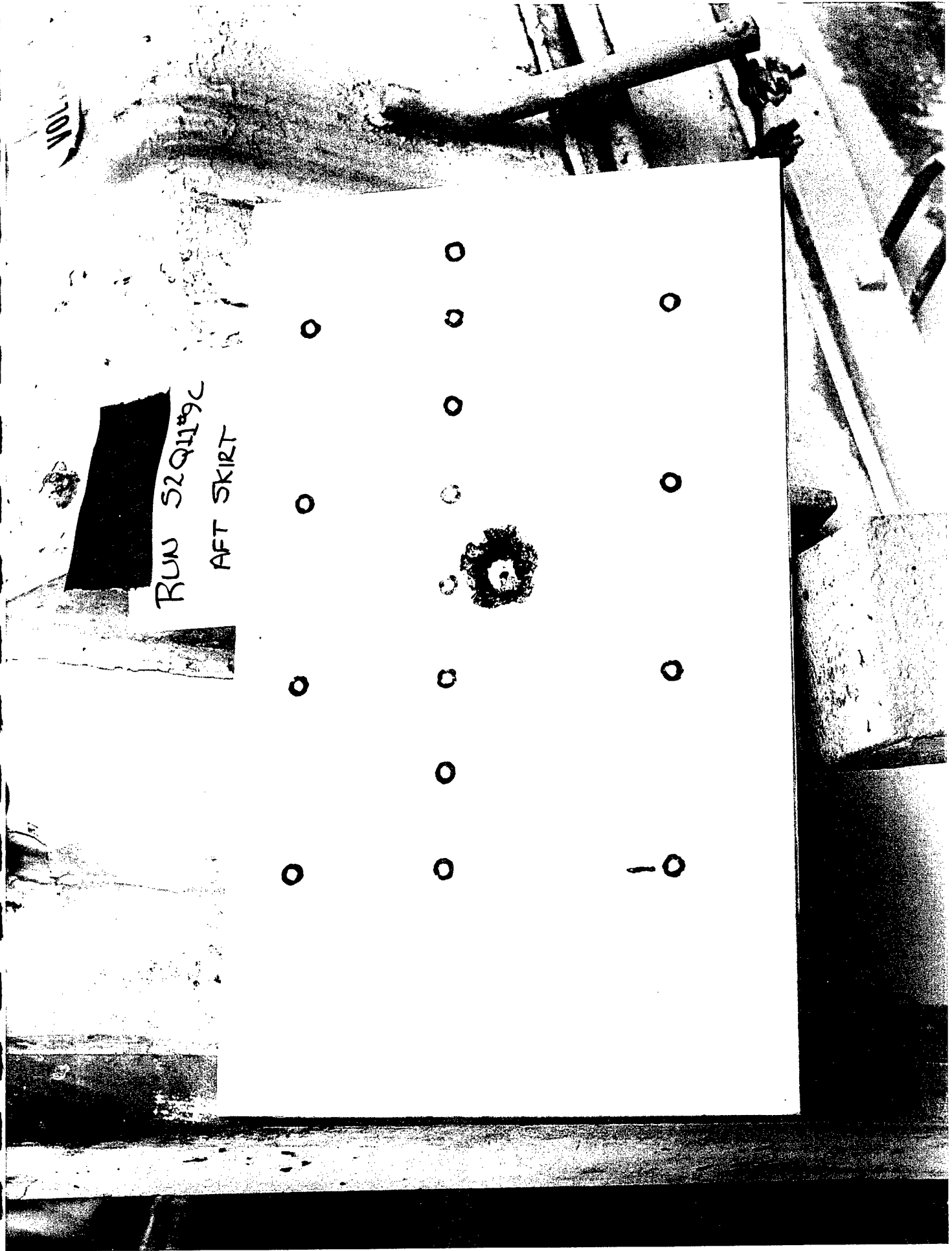

100

RUN 52Q11*9C
AFT SKIRT

Figure B-52. Cumulative Damage Due to Components A, B, and C to Panel Q-1#9, Front View.

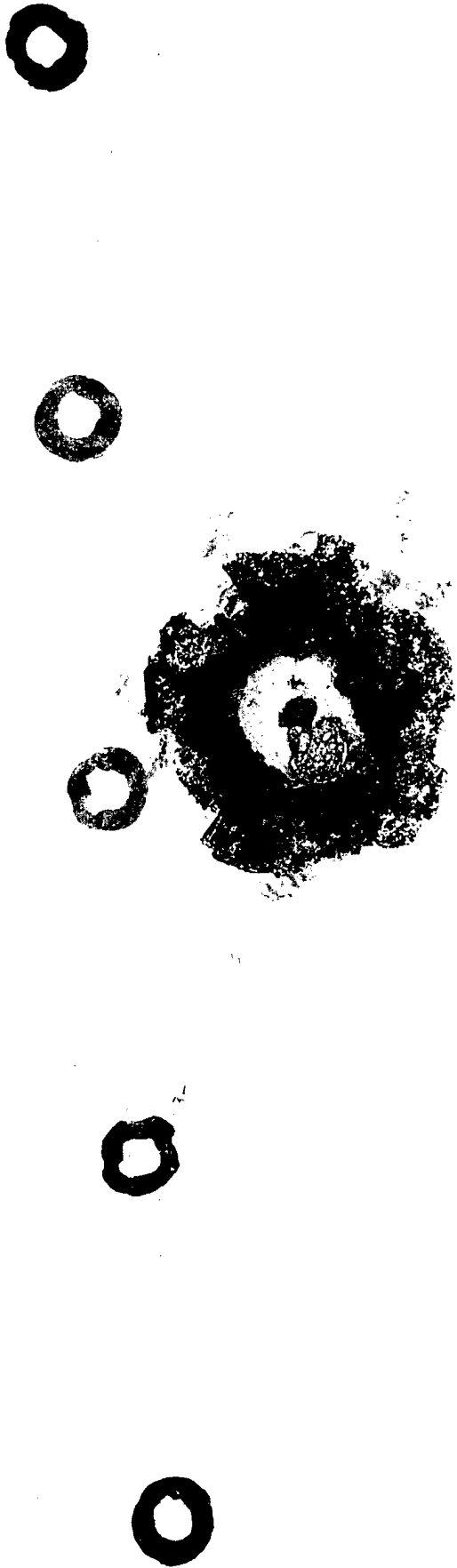
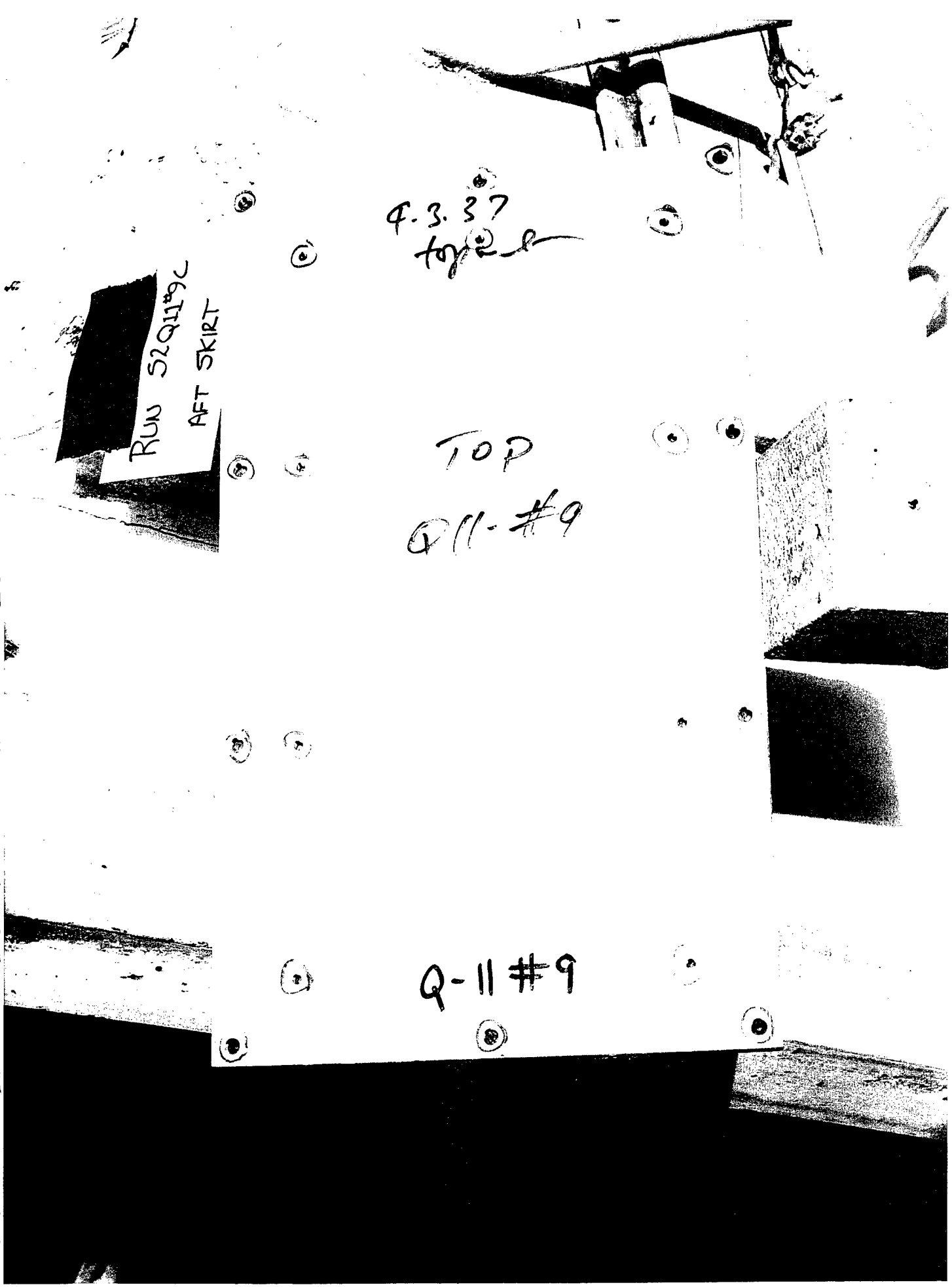

Figure B-53. Cumulative Damage Due to Components A, B, and C to Panel Q-11#9, Close Up View.



RUN 52Q11#9C
AFT SKIRT

4.3.37
top

TOP
Q-11-#9

Q-11 #9

Figure B-54. Cumulative Damage Due to Components A, B, and C to Panel Q-11#9, Back View.

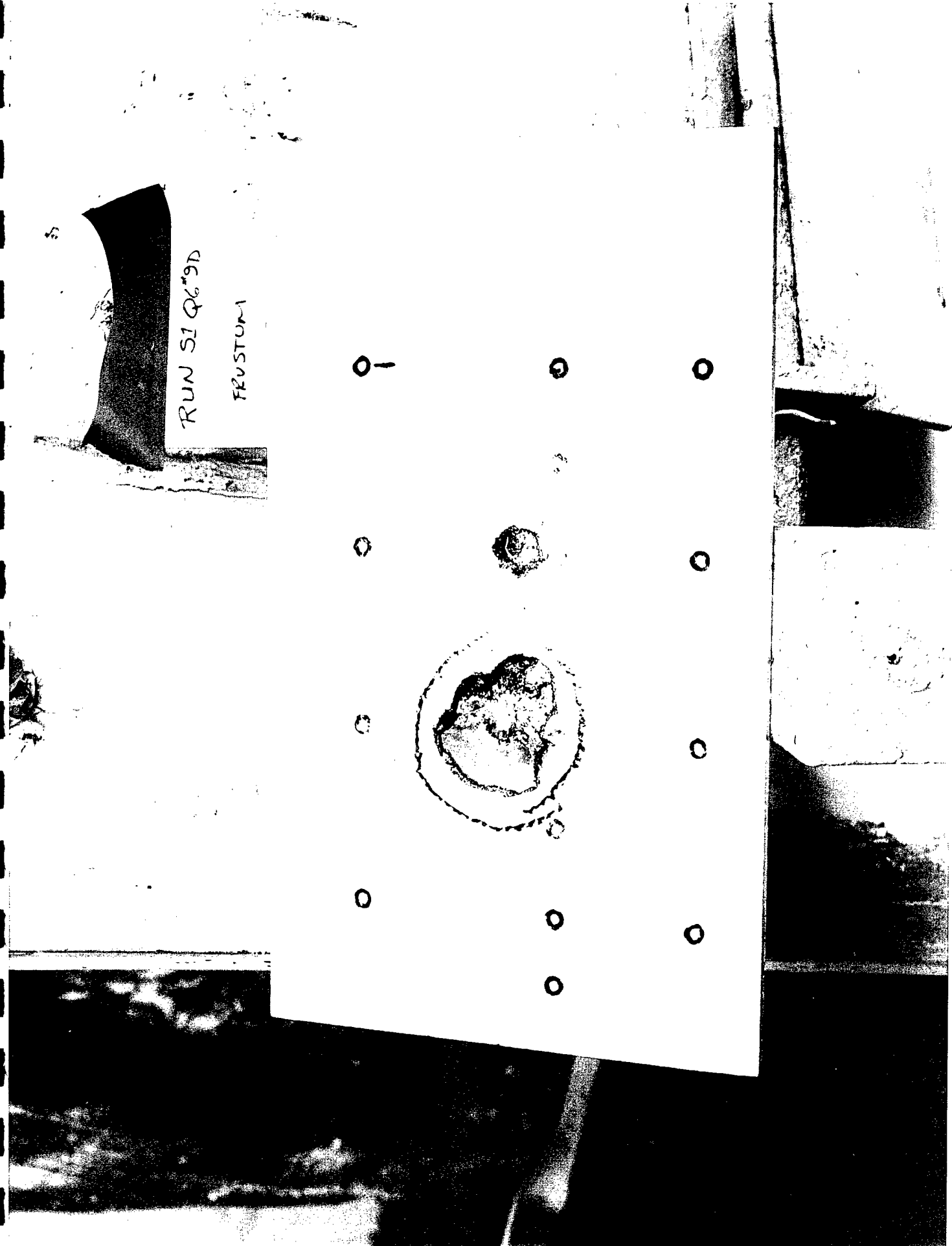

RUN SI Q6*9D

FRUSTUM

Figure B-55. Cumulative Damage Due to Components A, B, C, and D to Panel Q-6#9, Front View.



Figure B-56. Cumulative Damage Due to Components A, B, C, and D to Panel Q-6#9, Close Up View.

RUN SI Q69D

FRUSTUM

6#9-0

TOP
86#9
8-22-94
4.3.3.2

READING EDGE 3.1
3 1/16" Nominale
Lightning strike Pan

Figure B-57. Cumulative Damage Due to Components A, B, C, and D to Panel Q-6#9, Back View.

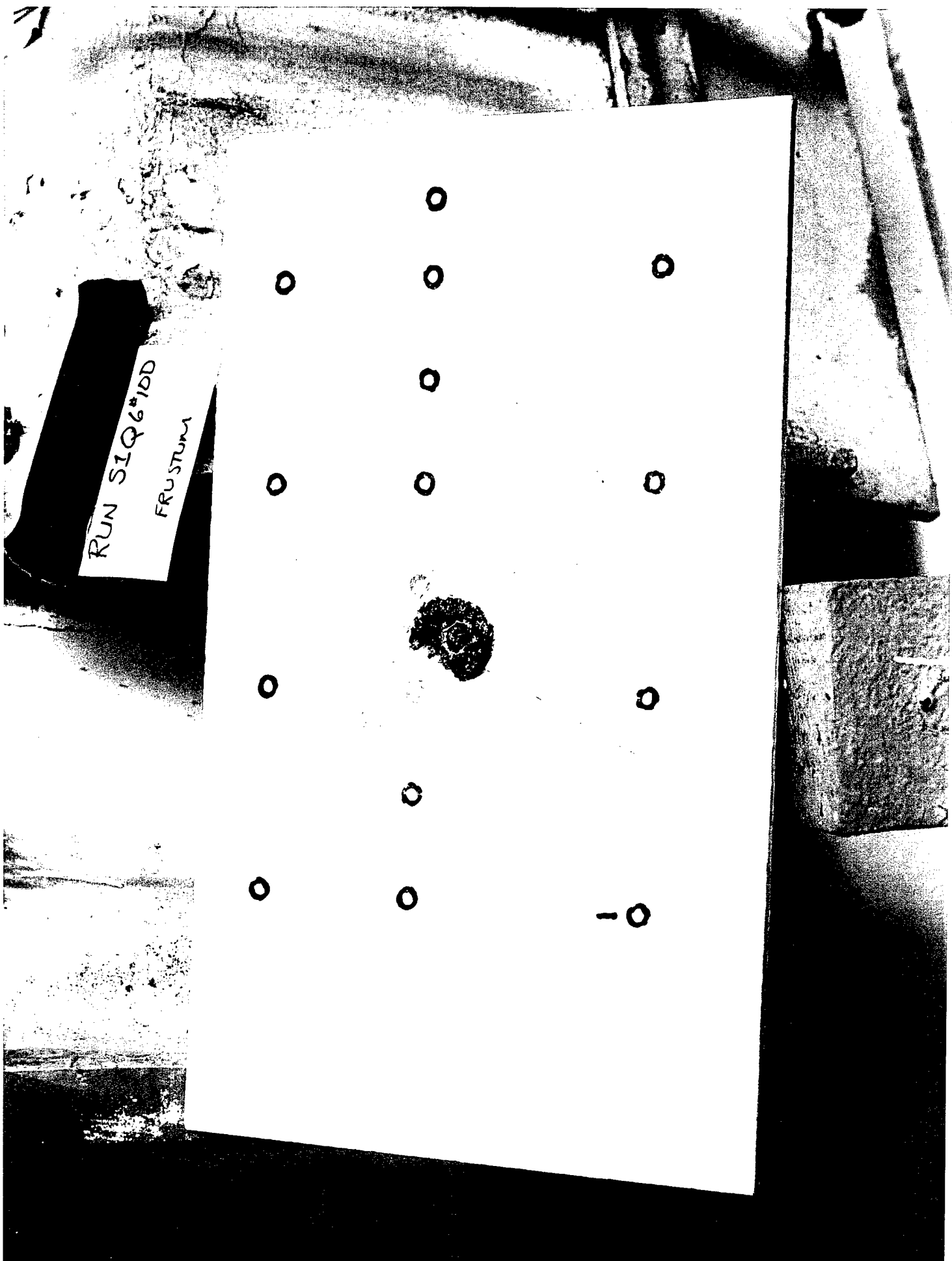

RUN SIQ6*10D
FRUSTUM

Figure B-58. Cumulative Damage Due to Components A, B, C, and D to Panel Q-6#10, Front View.

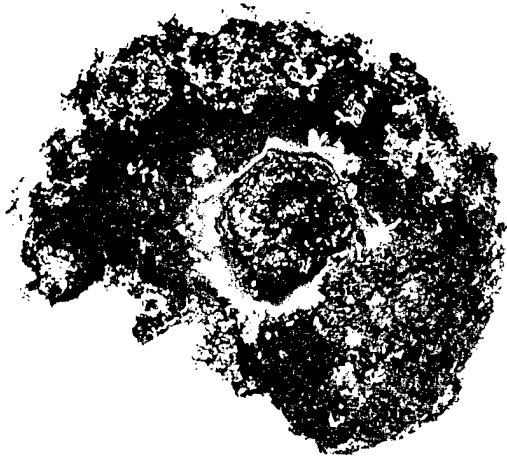

Figure B-59. Cumulative Damage Due to Components A, B, C, and D to Panel Q-6#10, Close Up View.

RUN SIQ6#10D

FRUSTUM

LEADING
EDGE

3/16 Nominal
Lightning strike Panel

TOP

Q6 #10

8.22-94

4.3.3.7

Q-6 #10

Figure B-60. Cumulative Damage Due to Components A, B, C, and D to Panel Q-6#10. Back View.

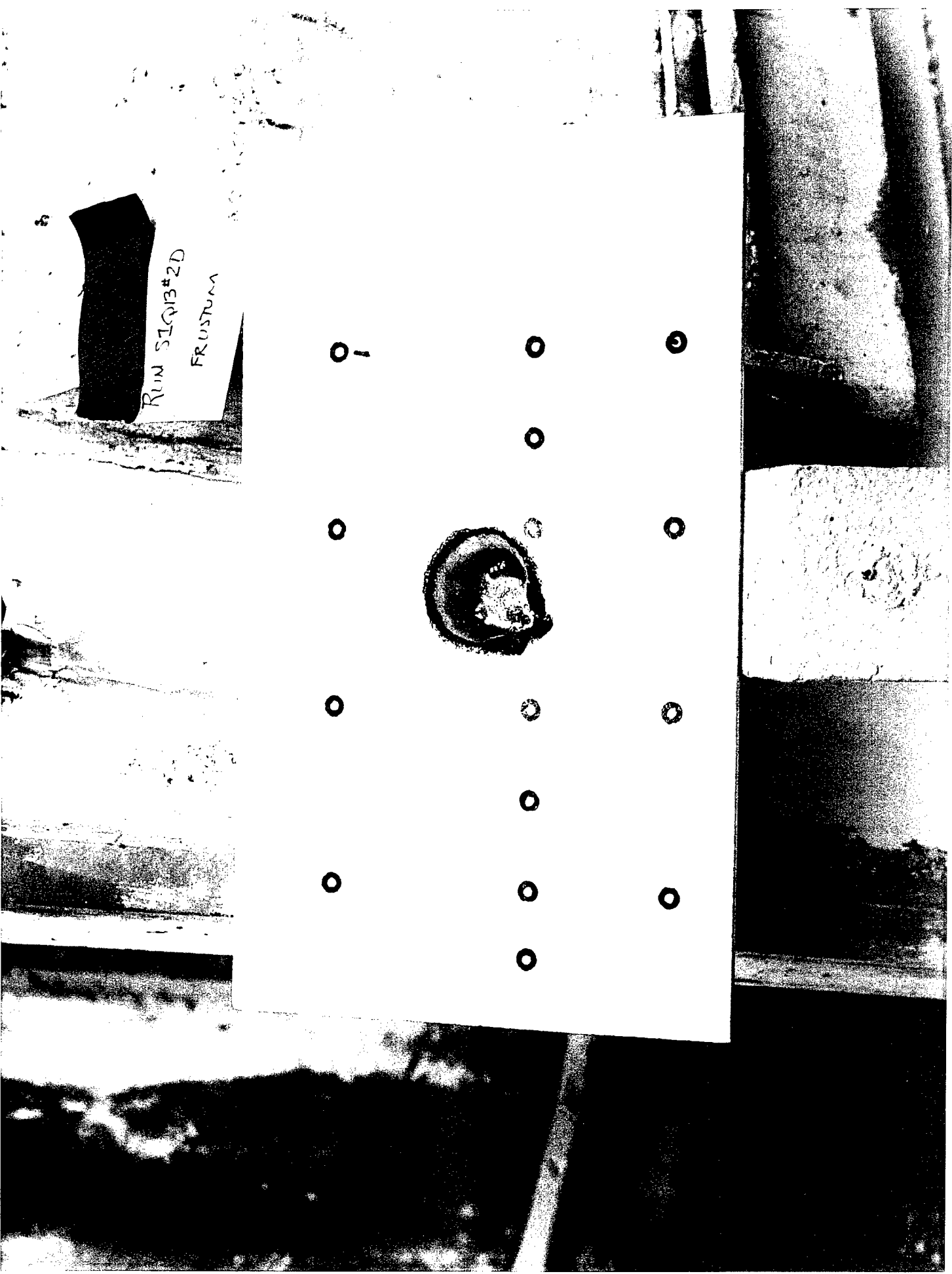

RUN SIGIB#2D
FRUSTUM

Figure B-61. Cumulative Damage Due to Components A, B, C, and D to Panel Q-13#2, Front View.



Figure B-62. Cumulative Damage Due to Components A, B, C, and D to Panel Q-13#2, Close Up View.



RUN SIGIB#2D
FRUSTUM

Q-13 #2

Q-13 #2

TOP CENTER

9-29-94

4.33.7

Q-13 #2

Figure B-63. Cumulative Damage Due to Components A, B, C, and D to Panel Q-13#2, Back View.

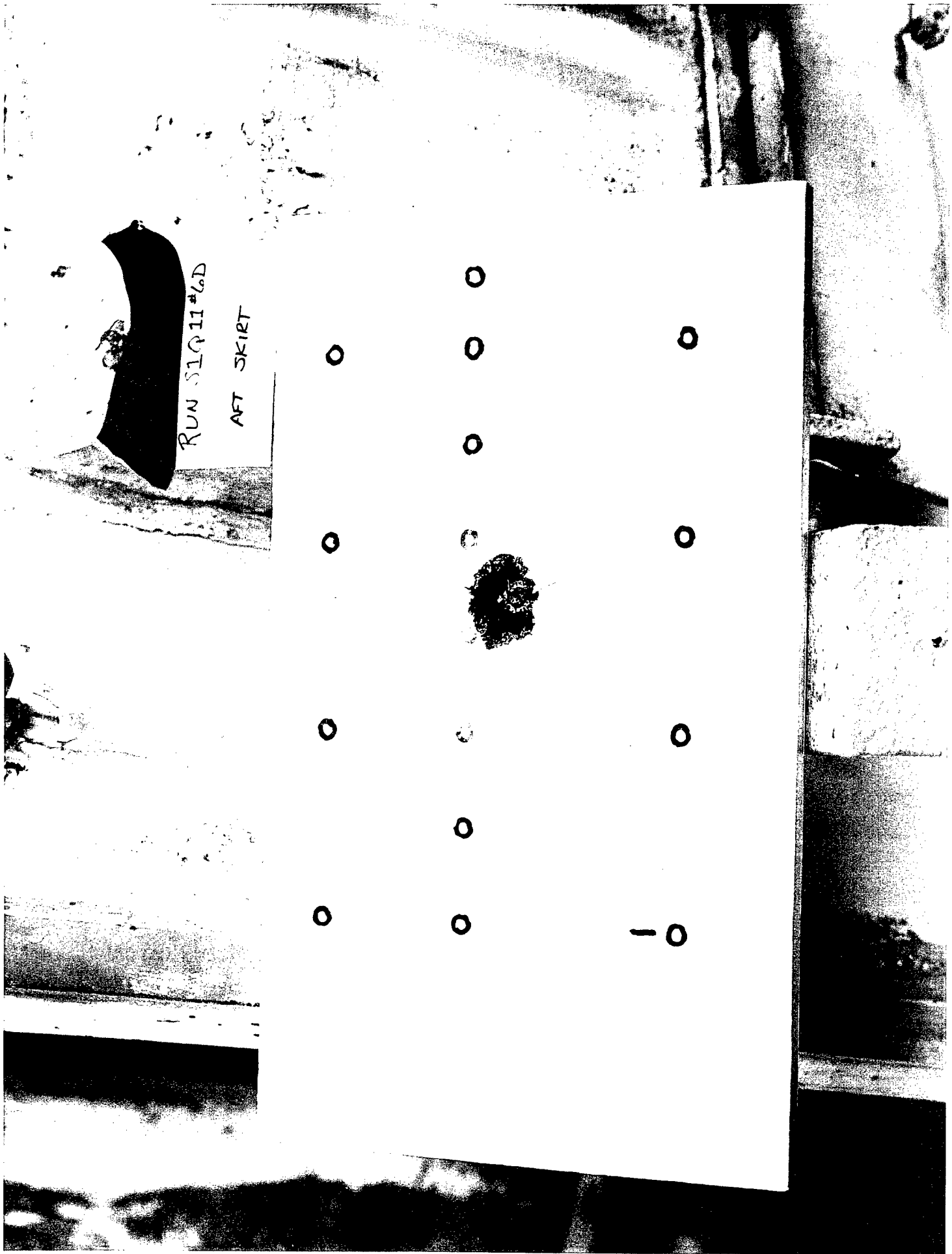

Figure B-64. Cumulative Damage Due to Components A, B, C, and D to Panel Q-11#6, Front View.

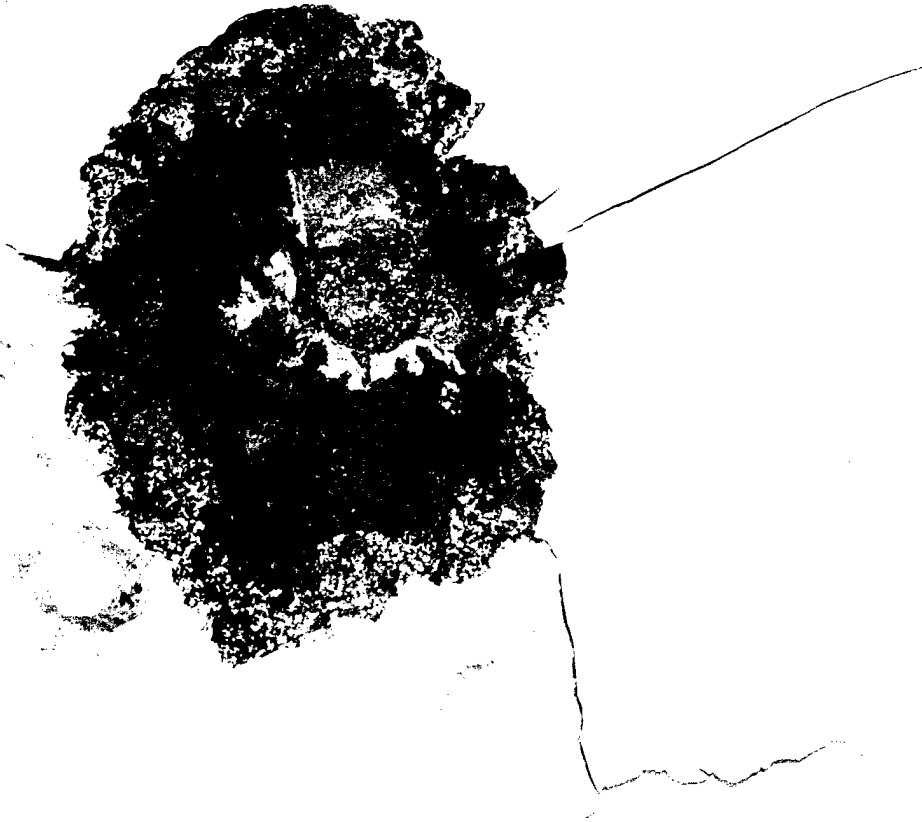
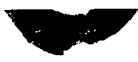
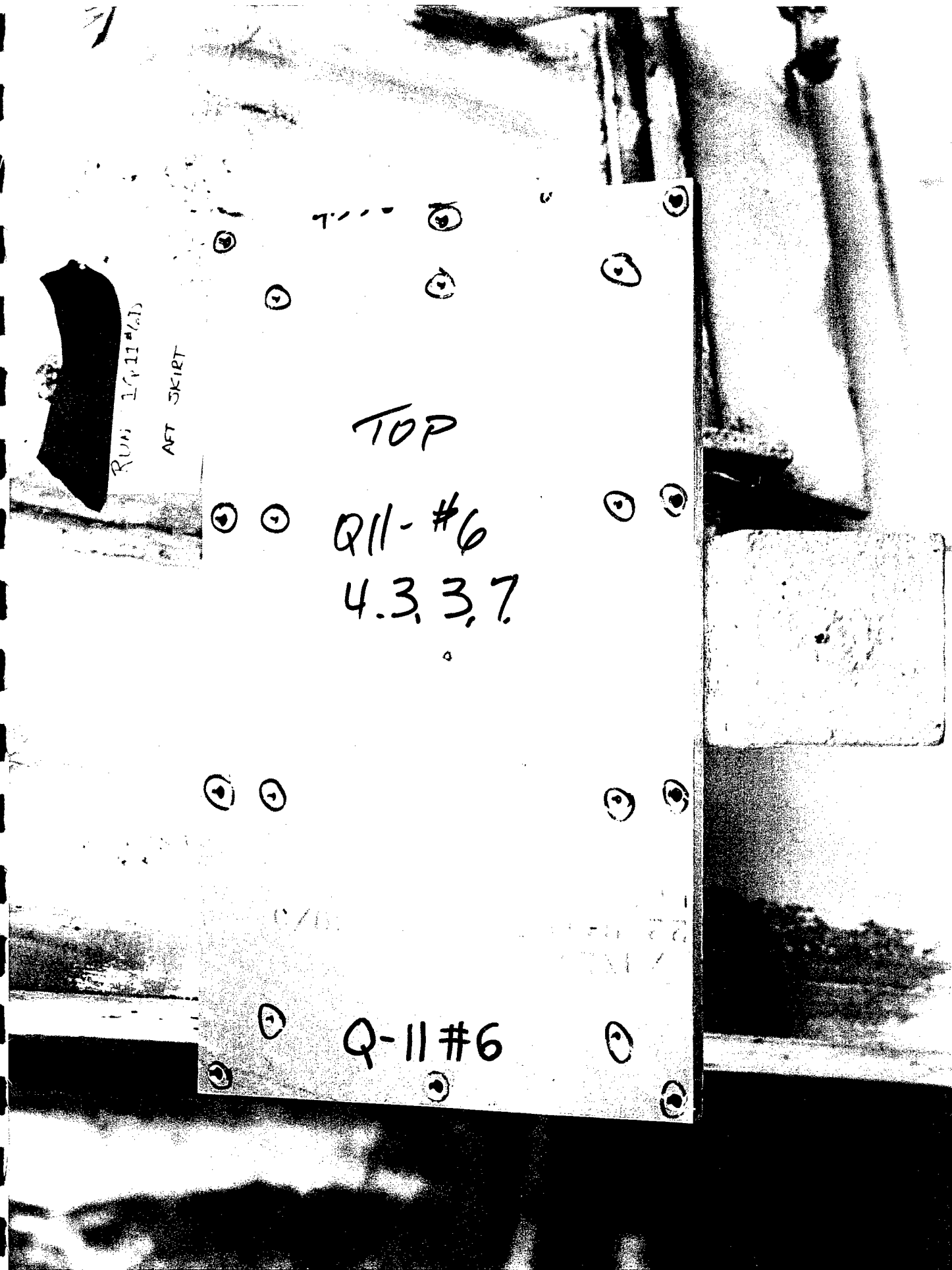

Figure B-65. Cumulative Damage Due to Components A, B, C, and D to Panel Q-11#6, Close Up View.



RUN 141114AD

AFT SKIRT

TOP

Q11-#6

4.3.3.7

Q-11#6

Figure B-66. Cumulative Damage Due to Components A, B, C, and D to Panel Q-11#6, Back View.

RUN 516118D

AFT SKIRT

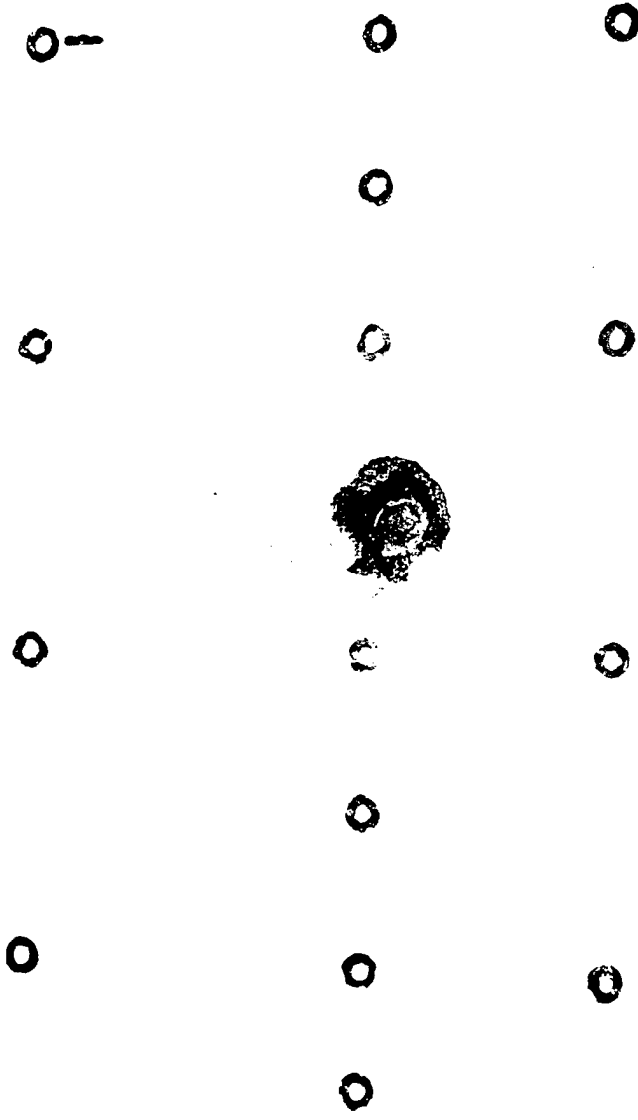

Figure B-67. Cumulative Damage Due to Components A, B, C, and D to Panel Q-11#8, Front View.

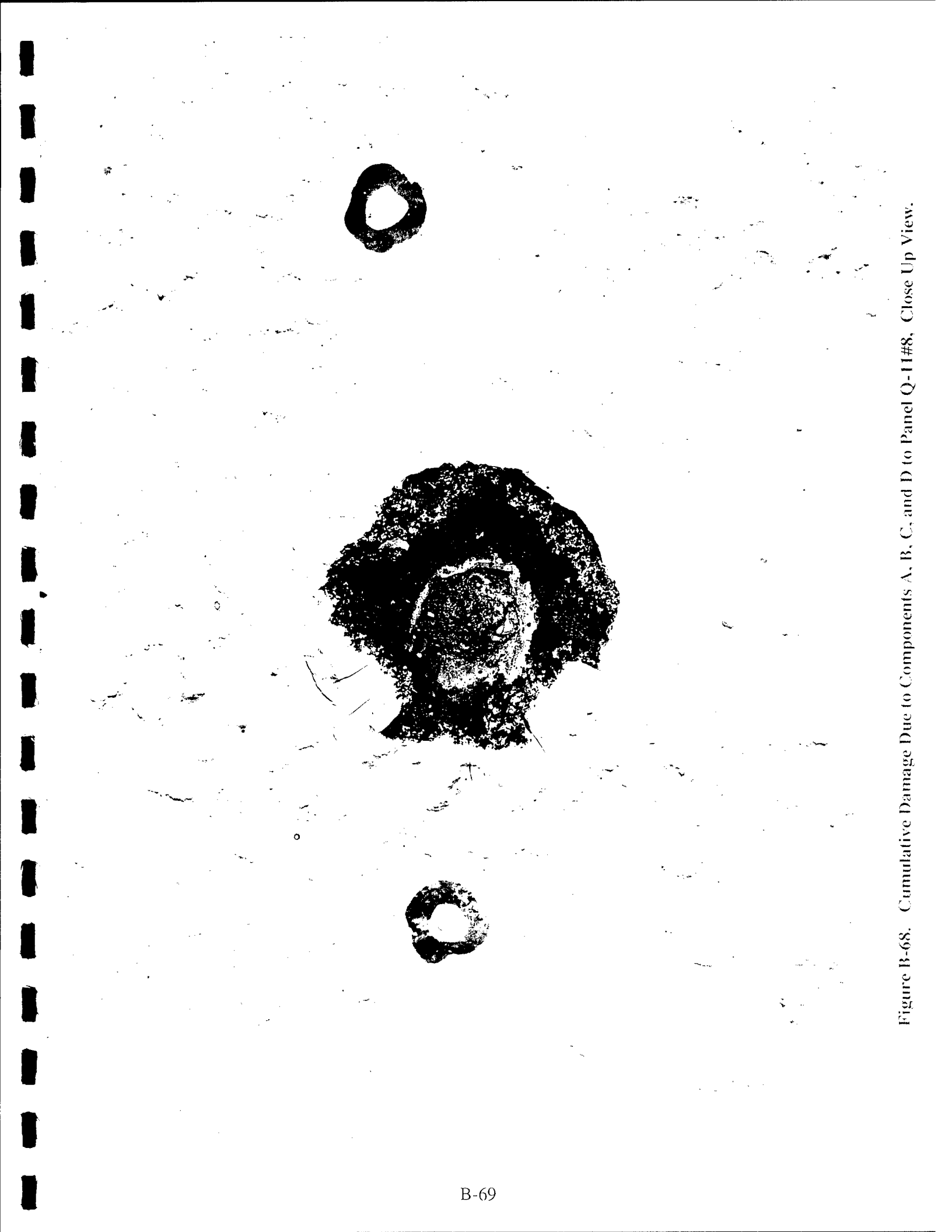
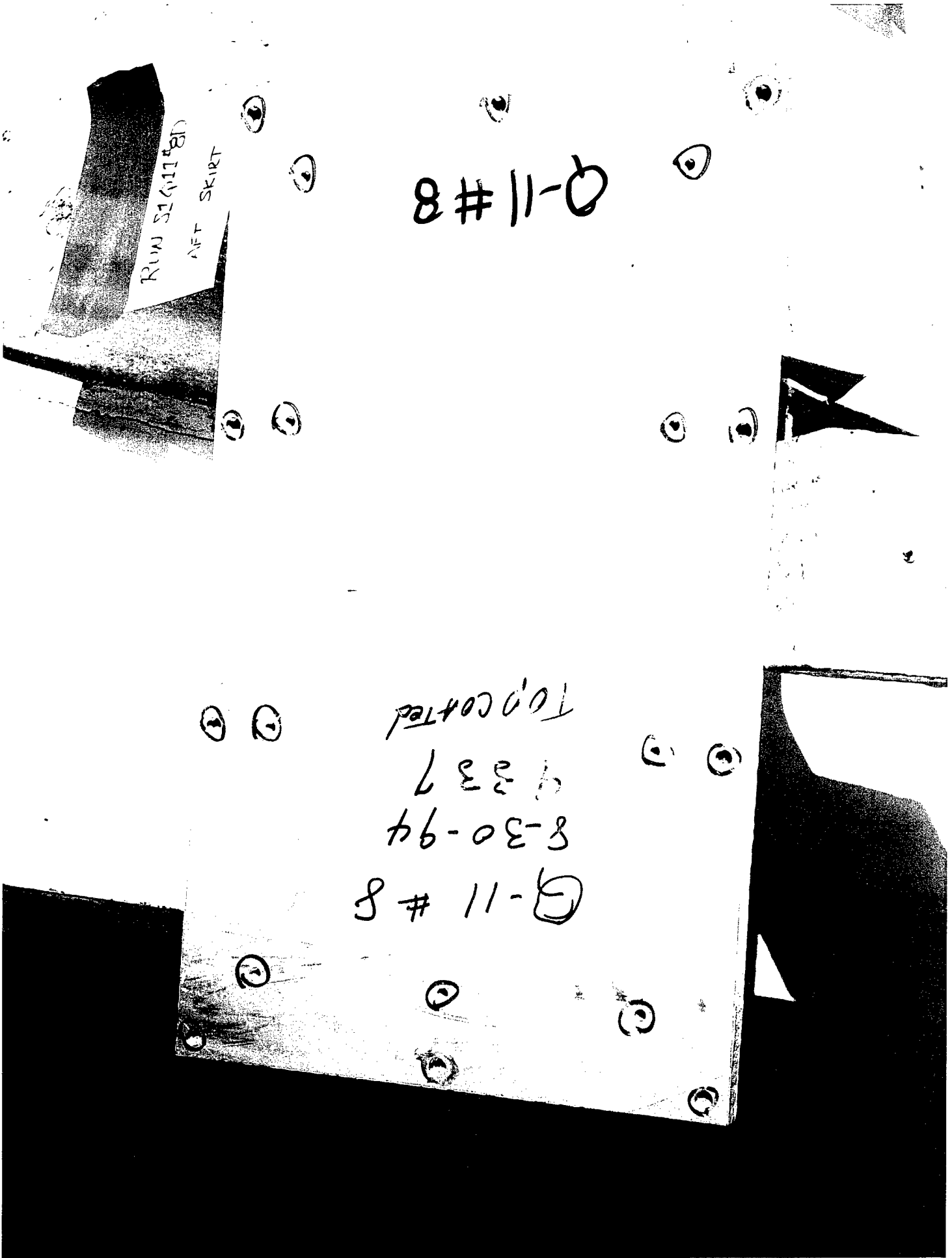

Figure B-68. Cumulative Damage Due to Components A, B, C, and D to Panel Q-11#8, Close Up View.



RUM SIGHT
AFT SKIRT

Q-11-8

Q-11-8
8-30-94
4337
TOP COATED

Figure B-69. Cumulative Damage Due to Components A, B, C, and D to Panel Q-11#8. Back View.

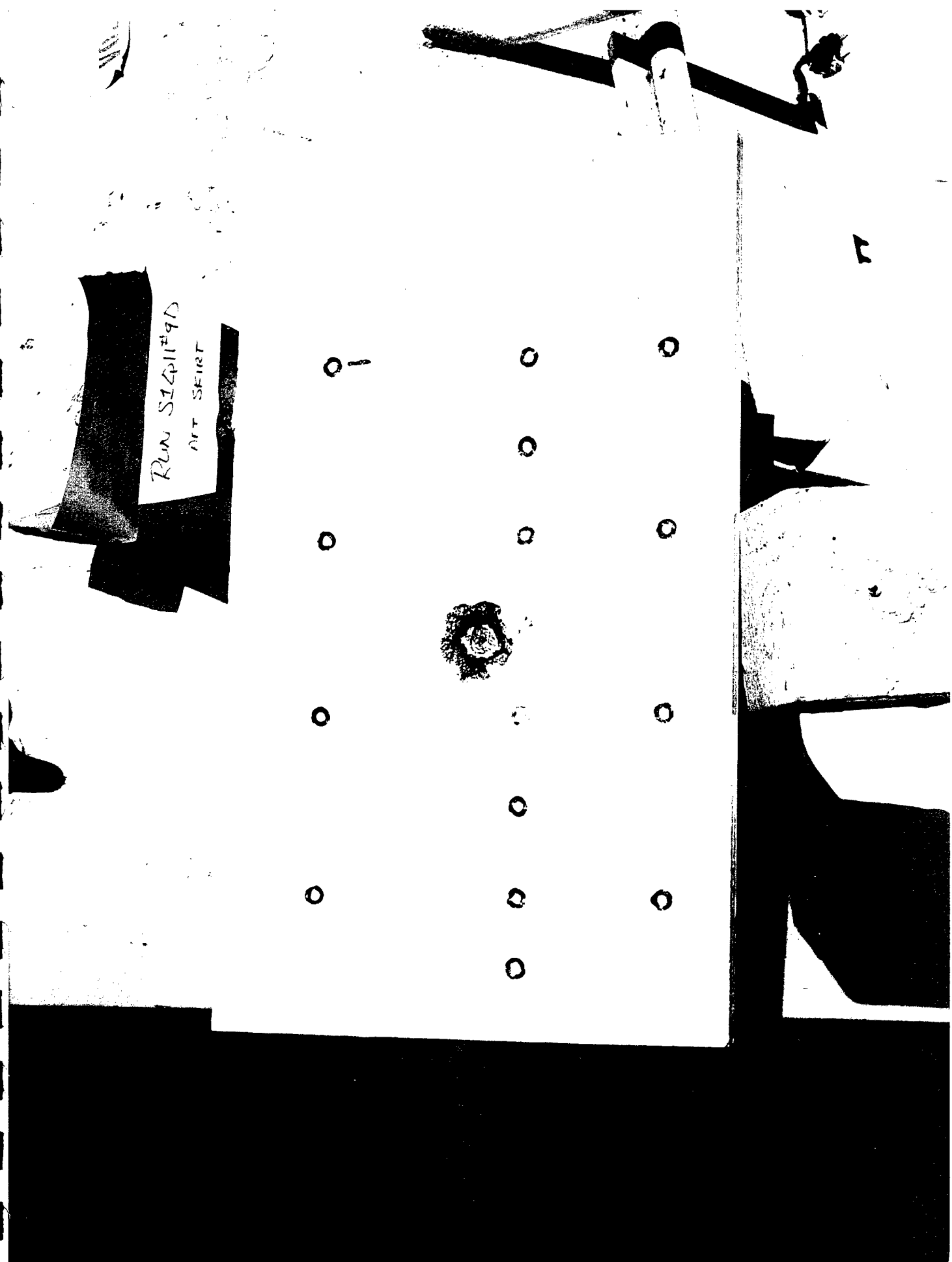

Run SIGINT#9D
ART SEIRT

Figure B-70. Cumulative Damage Due to Components A, B, C, and D to Panel Q-11#9, Front View.

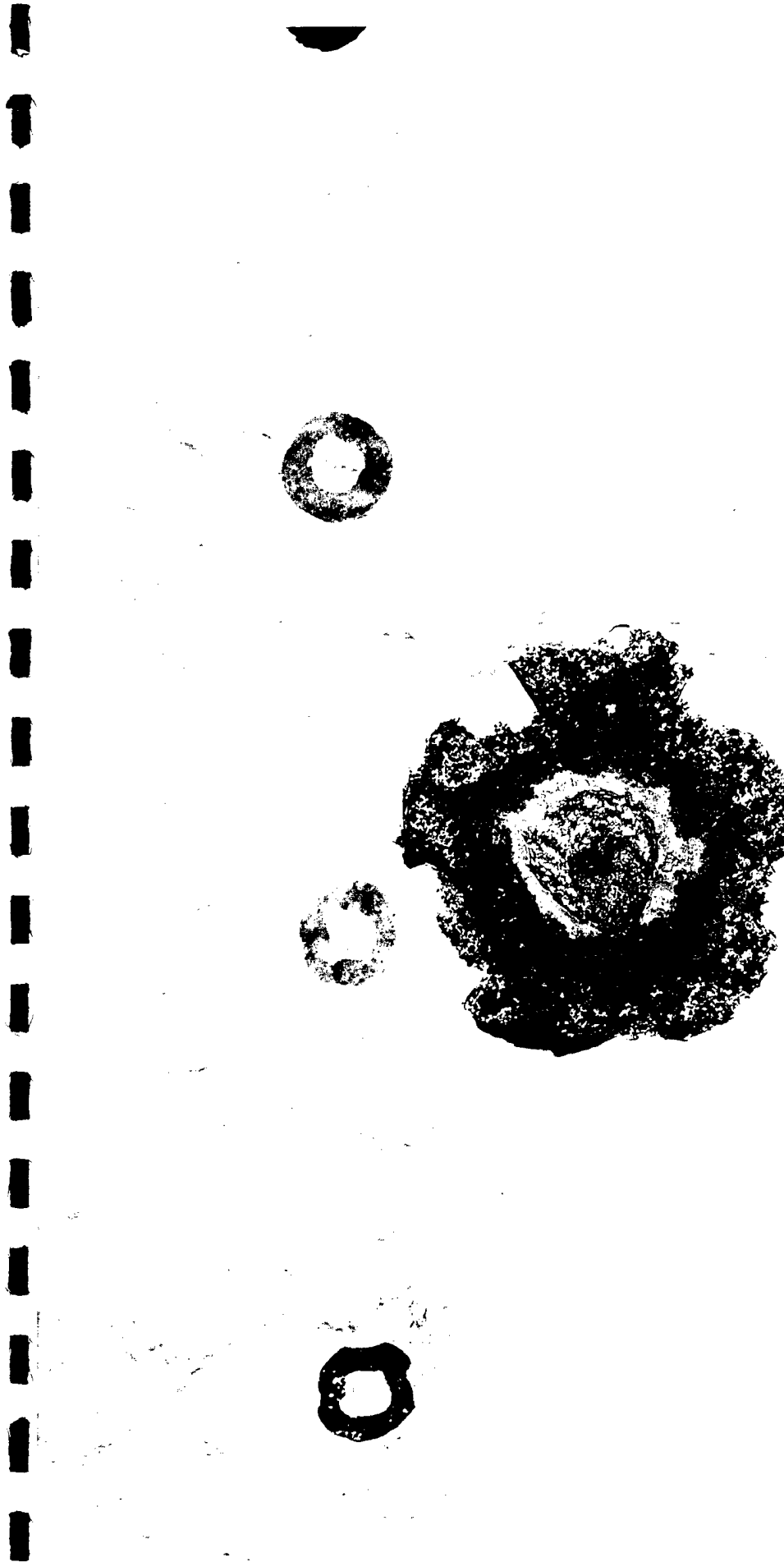

Figure B-71. Cumulative Damage Due to Components A, B, C, and D to Panel Q-11#9, Close Up View.

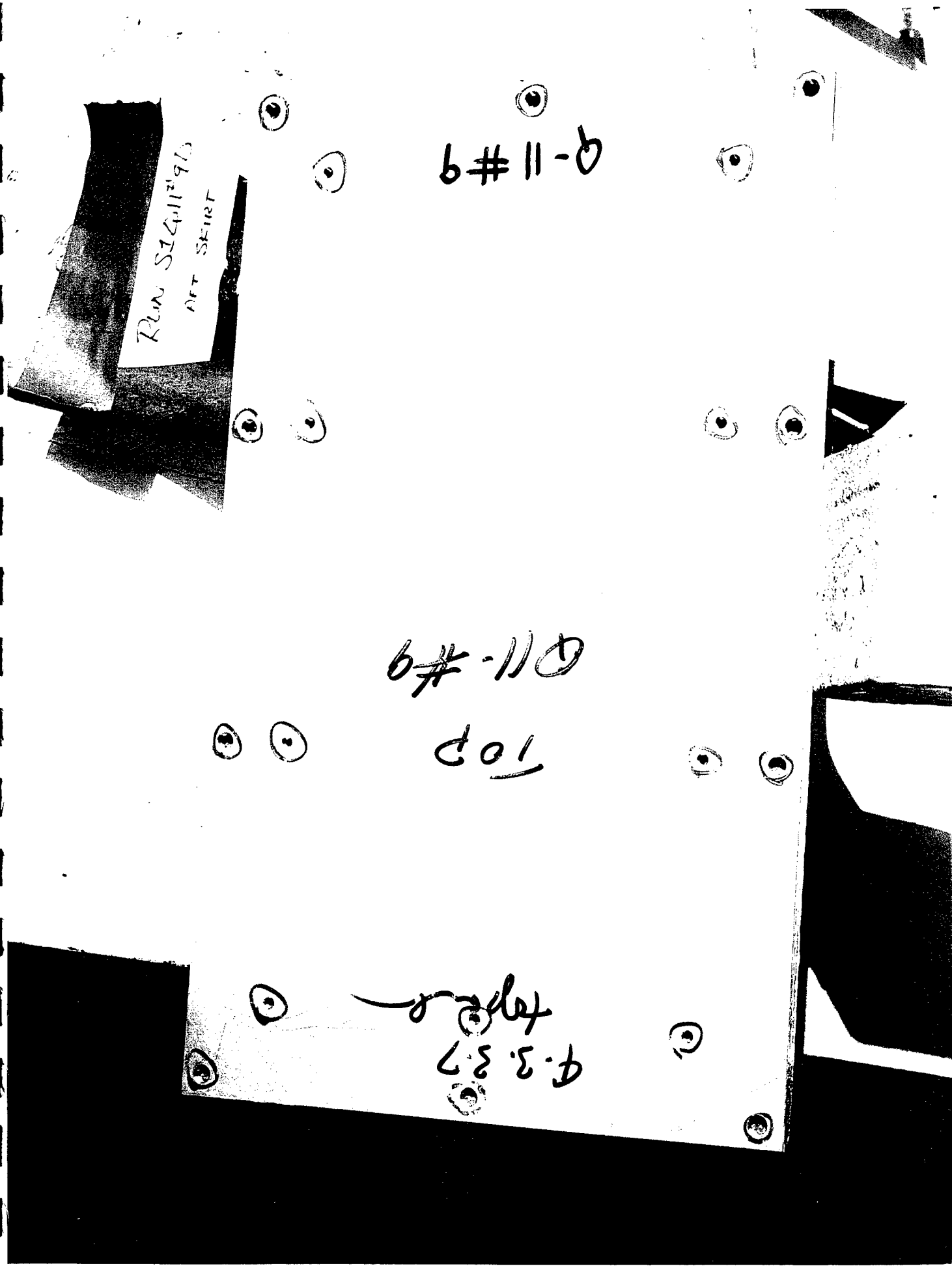

Figure B-72. Cumulative Damage Due to Components A, B, C, and D to Panel Q-11#9, Back View.



Figure B-73. Resultant Damage Due to Component A to Panel TTC5#16, Front View (No Gap).

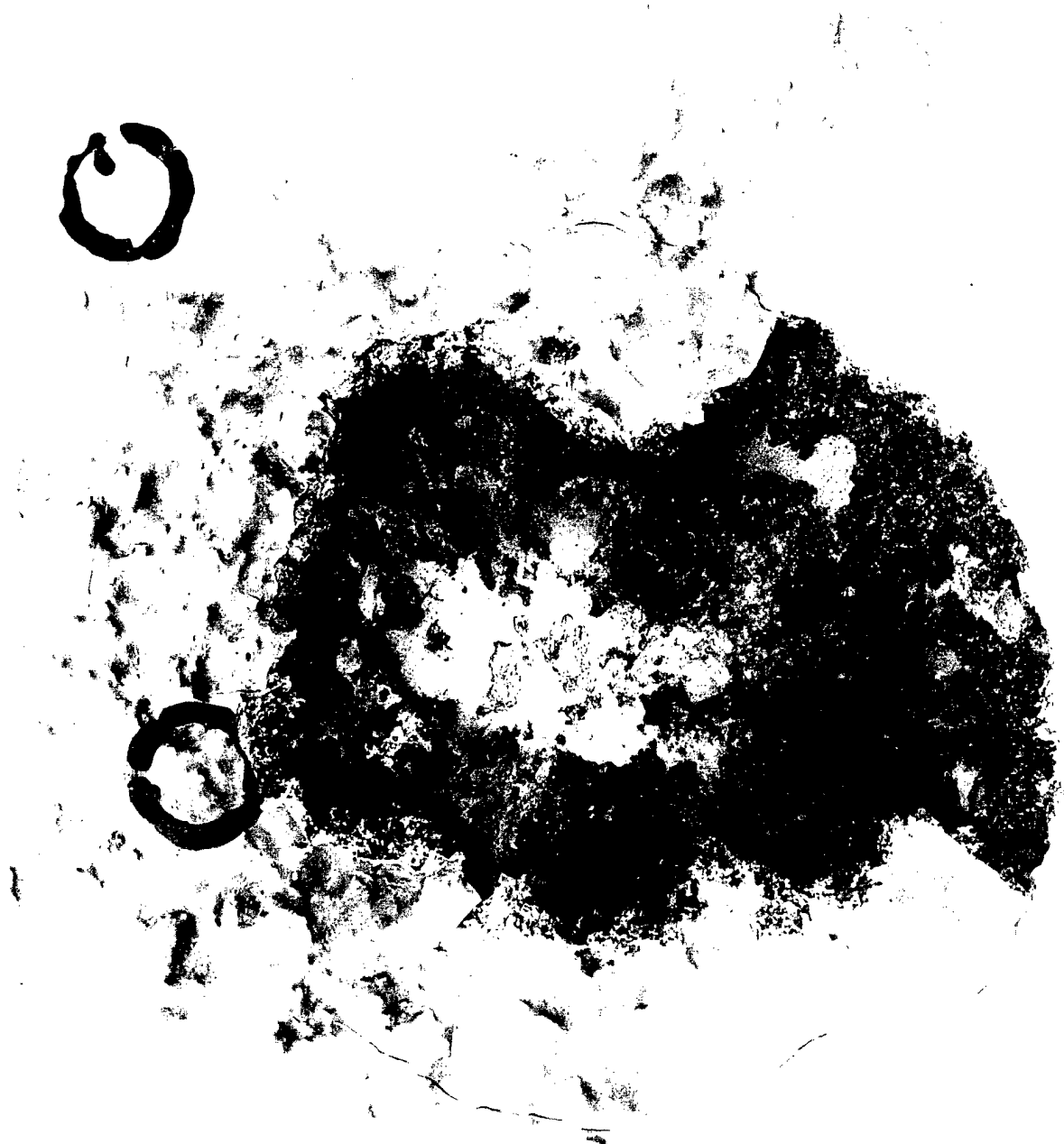

Figure B-74. Resultant Damage Due to Component A to Panel TTC5#16, Close Up View (No Gap).

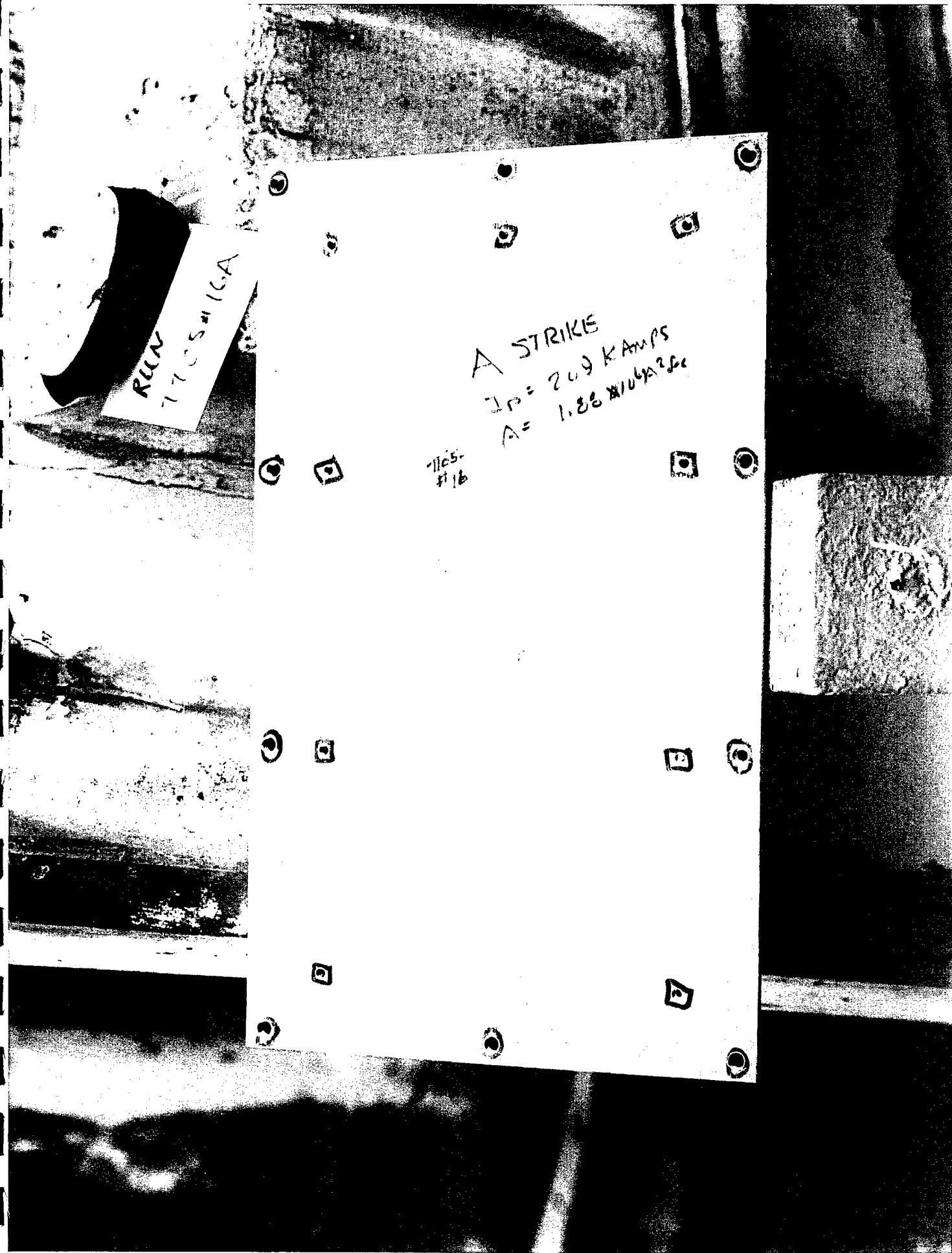
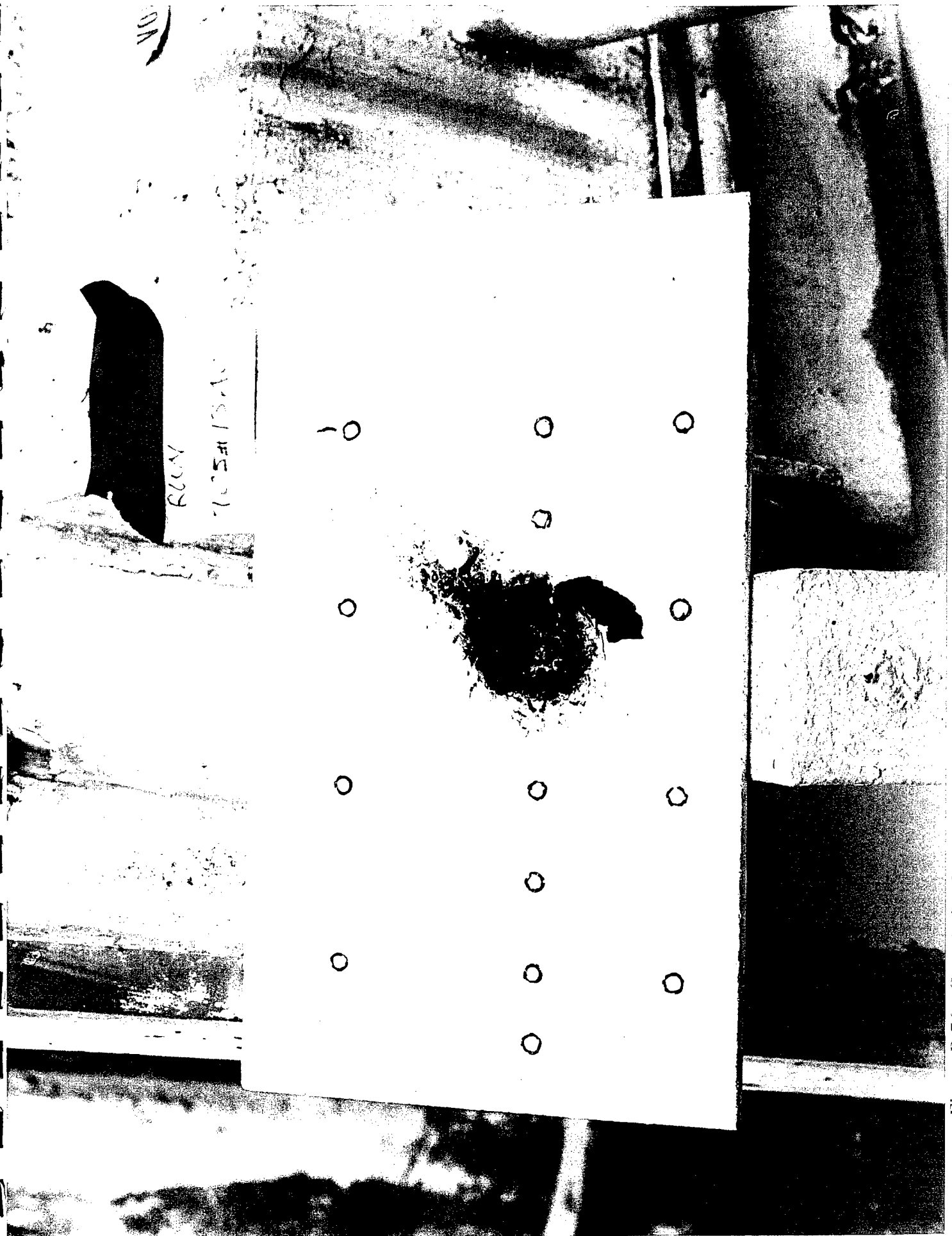

Figure B-75. Resultant Damage Due to Component A to Panel TTC5#16. Back View (No Gap).



NO

RUCY

TTC5#13.A

Figure B-76. Cumulative Damage Due to Simultaneous Components A and B to Panel TTC5#13, Front View.



Figure B-77. Cumulative Damage Due to Simultaneous Components A and B to Panel TTC5#13. Close Up View.

A&C Component

TTC-5 #13

RUN
TCS#13AC

Figure B-78. Cumulative Damage Due to Simultaneous Components A and B to Panel TTC5#13. Back View.

APPENDIX C
TEST DATA

Filename: SRBCALA1.RAW
 Date: 01-17-1995
 Time: 10:02:14

Action Integral(Channel 1) = $1.455056E-05 (70\mu)^2 (500)^2 = 1.82 E6 A^2 \cdot sec$

Quick-Look Plot from HP54510A
 GPIBAddress 07 Channel 1

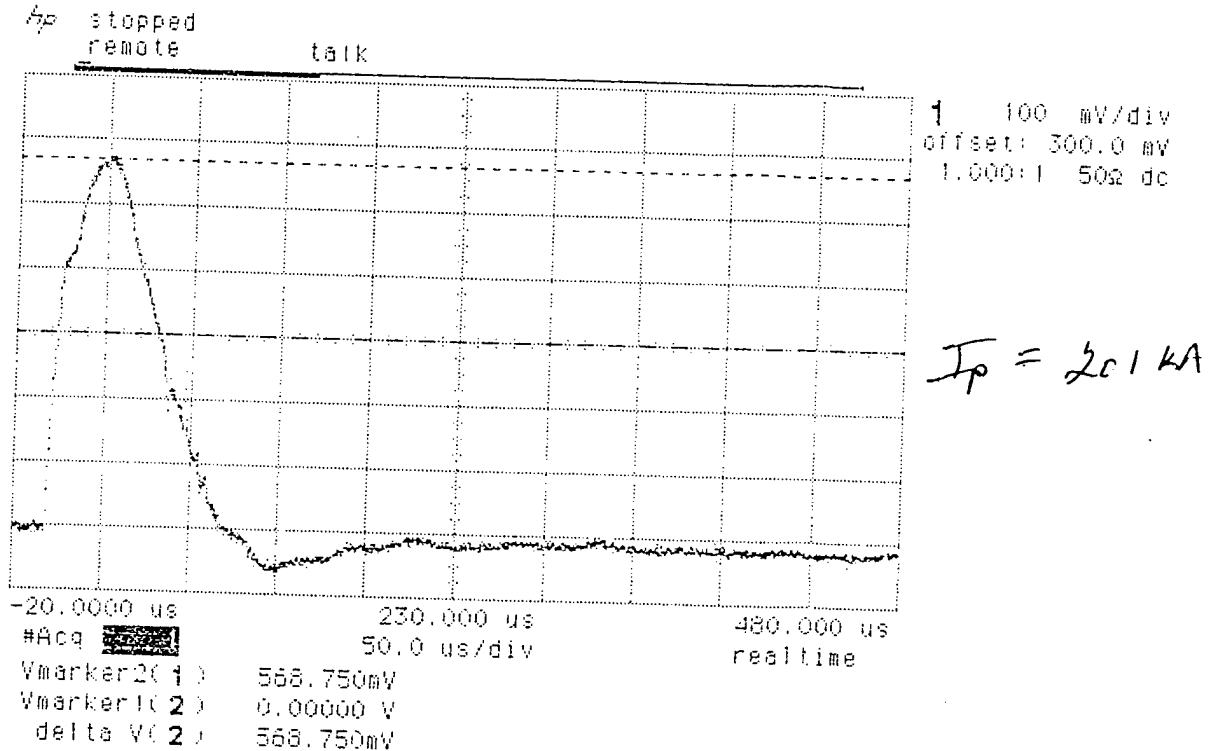

1 100.0 mV

| Channel 1 | Sensitivity | Offset | Probe | Coupling | Impedance |
|-----------|-------------|------------|-------|----------|-----------|
| | 100 mV/div | 300.000 mV | 1:1 | dc | 50 ohm |

Trigger Mode: Edge
 On the Positive Edge of Channel 1
 Trigger Level(s)
 Channel 1 = 100,000 mV (noise reject OFF)
 HoldOff = 40.000 n/s

Figure C-1. Measurement of Component A Calibration Waveform on the Frustum Panel.

Filename: SRBCALA2.RAW
 Date: 01-17-1995
 Time: 10:16:32

Action Integral(Channel 1) = $1.438409E-05 (708)^2 (500)^2 = 1.80 E6 A^2 \cdot sec.$

Quick-Look Plot from HP54510A
 GPIBaddress 07 Channel 1

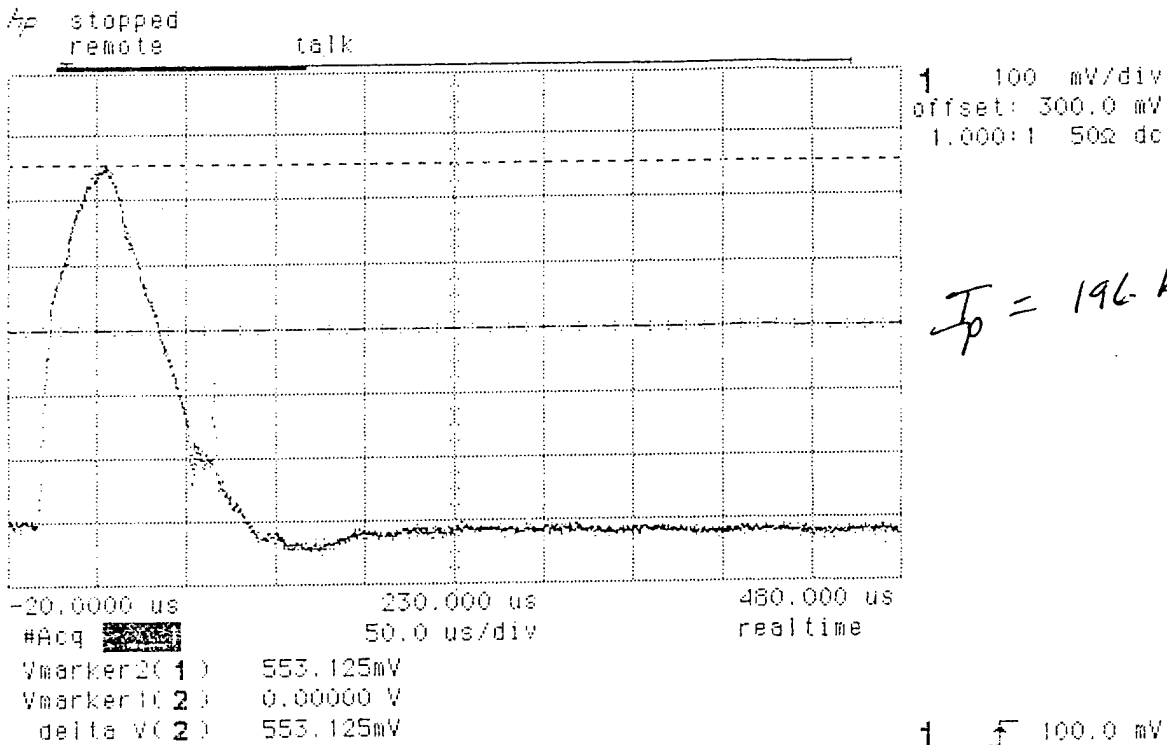

| Channel | Sensitivity | Offset | Probe | Coupling | Impedance |
|---------|-------------|------------|-------|----------|-----------|
| 1 | 100 mV/div | 300.000 mV | 1:1 | dc | 50 ohm |

Trigger Mode: Edge
 On the Positive Edge of Channel 1
 Trigger Level(s)
 Channel 1 = 100,000 mV (noise reject OFF)
 HoldOff = 40.000 n/s

Figure C-2. Measurement of Component A Calibration Waveform on the Aft Skirt Panel.

Filename: SS106#9A.RAW
Date: 01-17-1995
Time: 12:27:17

Bad Data

Action Integral(Channel 1) = 1.555956E-07

Quick-Look Plot from HP54510A
GPIBaddress 07 Channel 1

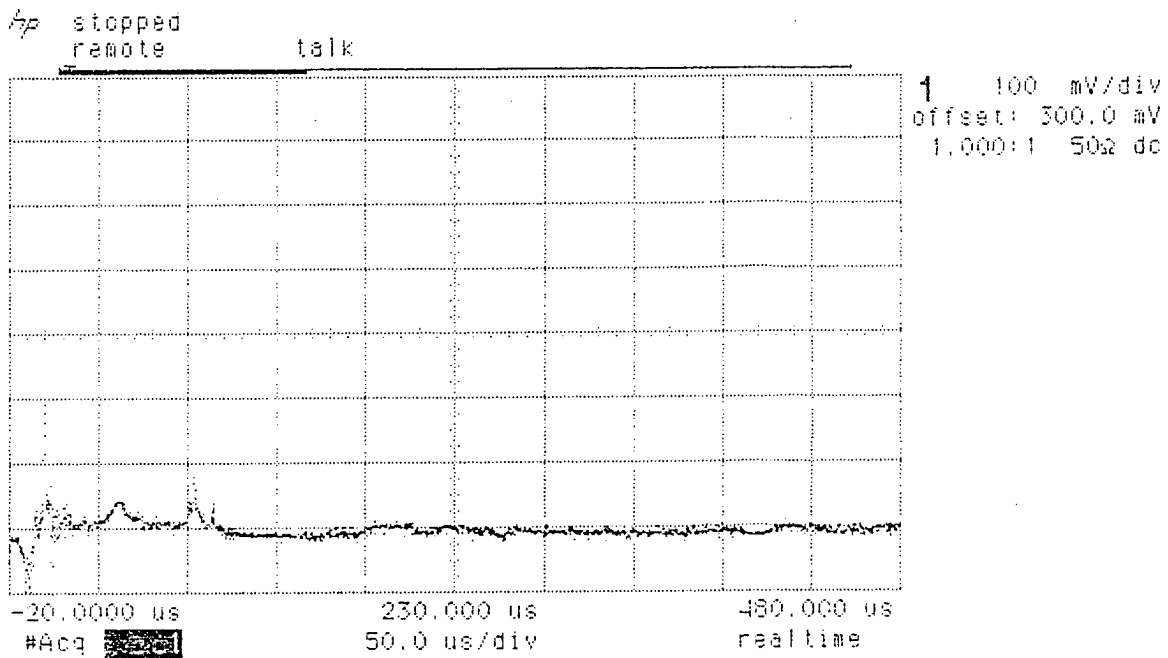

1 100.0 mV

| | Sensitivity | Offset | Probe | Coupling | Impedance |
|-----------|-------------|------------|-------|----------|-----------|
| Channel 1 | 100 mV/div | 300.000 mV | 1:1 | dc | 50 ohm |

Trigger Mode: Edge
On the Positive Edge of Channel 1
Trigger Level(s)
Channel 1 = 100,000 mV (noise reject OFF)
HoldOff = 40,000 n/s

Figure C-3. Measurement of Component A Waveform on Panel Q6#9 (Instrumentation Malfunction).

Filename: SS2Q6#9A.RAW
 Date: 01-17-1995
 Time: 13:18:04

Action Integral(Channel 1) = $1.552087E-05 (708)^2 (500 A/V)^2 = 1.94 E6 A^2 \cdot sec$

Quick-Look Plot from HP54510A
 GPIBaddress 07 Channel 1

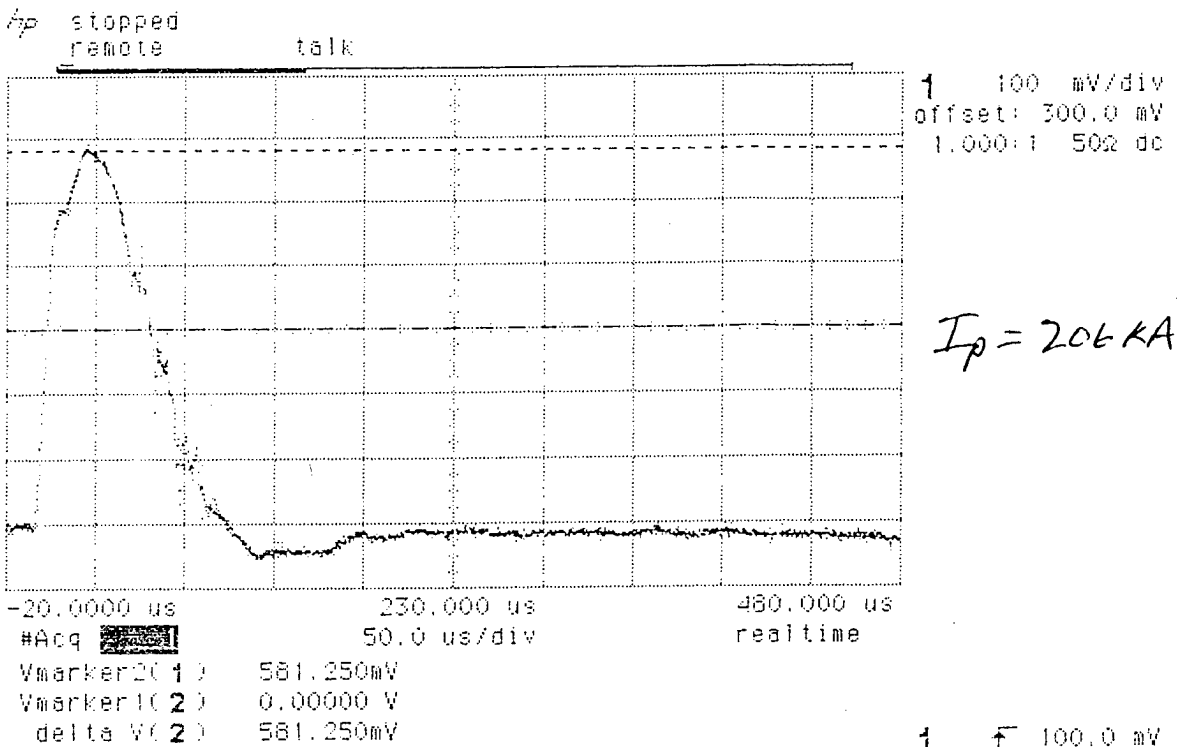

| | Sensitivity | Offset | Probe | Coupling | Impedance |
|-----------|-------------|------------|-------|----------|-----------|
| Channel 1 | 100 mV/div | 300.000 mV | 1:1 | dc | 50 ohm |

Trigger Mode: Edge
 On the Positive Edge of Channel 1
 Trigger Level(s)
 Channel 1 = 100,000 mV (noise reject OFF)
 HoldOff = 40.000 n/s

Figure C-4. Measurement of Component A Waveform on Panel Q6#9.

Filename: S1Q6#10A.RAW
 Date: 01-17-1995
 Time: 14:36:07

Action Integral(Channel 1) = $1.56301E-05 (708)^2 (500)^2 = 1.95 E6 A^2 \cdot sec$

Quick-Look Plot from HP54510A
 GPIBAddress 07 Channel 1

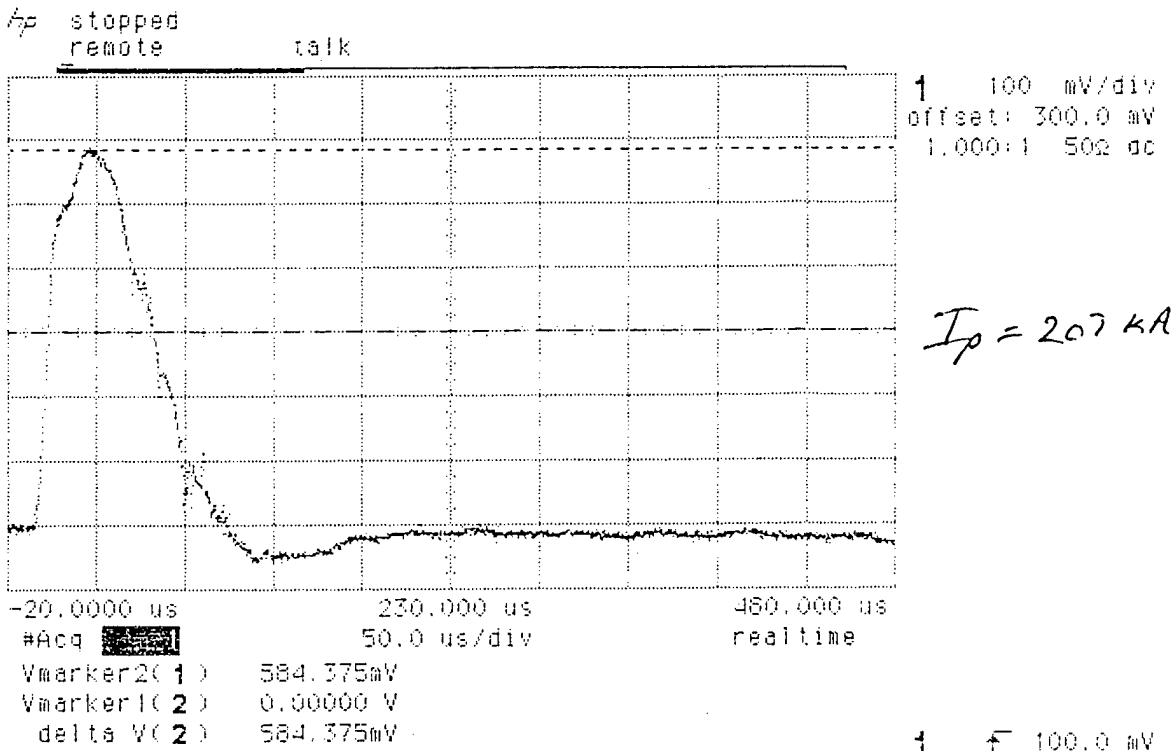

| | Sensitivity | Offset | Probe | Coupling | Impedance |
|-----------|-------------|------------|-------|----------|-----------|
| Channel 1 | 100 mV/div | 300.000 mV | 1:1 | dc | 50 ohm |

Trigger Mode: Edge
 On the Positive Edge of Channel 1
 Trigger Level(s)
 Channel 1 = 100,000 mV (noise reject OFF)
 HoldOff = 40.000 n/s

Figure C-5. Measurement of Component A Waveform on Panel Q6#10.

Filename: S1Q13#2A.RAW
 Date: 01-17-1995
 Time: 14:42:57

Action Integral(Channel 1) = $1.526847E-05 (708)^2 (500)^2 = 1.92 E6 A^2 \cdot sec$

Quick-Look Plot from HP54510A
 GPIBaddress 07 Channel 1

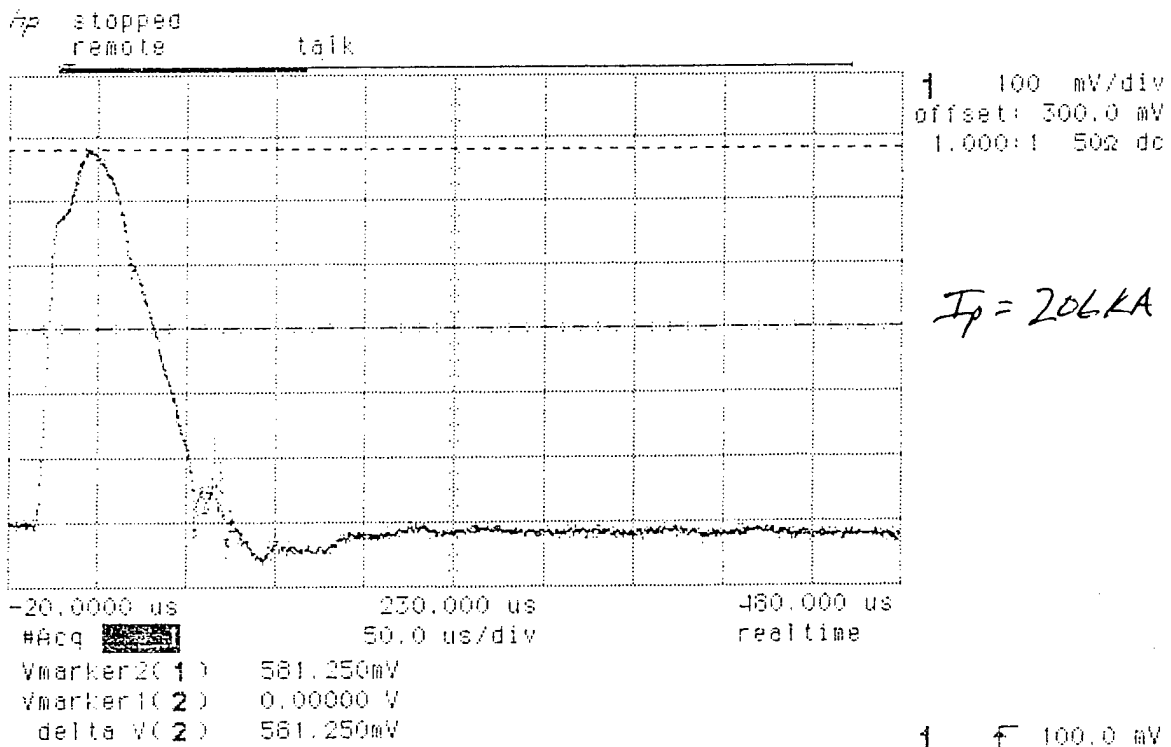

| | Sensitivity | Offset | Probe | Coupling | Impedance |
|-----------|-------------|------------|-------|----------|-----------|
| Channel 1 | 100 mV/div | 300.000 mV | 1:1 | dc | 50 ohm |

Trigger Mode: Edge
 On the Positive Edge of Channel 1
 Trigger Level(s)
 Channel 1 = 100,000 mV (noise reject OFF)
 HoldOff = 40.000 n/s

Figure C-6. Measurement of Component A Waveform on Panel Q13#2.

Filename: S1011#6A.RAW
 Date: 01-17-1995
 Time: 15:00:34

Action Integral(Channel 1) = $1.578818E-05 (708)^2 (500)^2 = 1.97E6 A^2 \cdot sec$

Quick-Lock Plot from HP54510A
 GPIBAddress 07 Channel 1

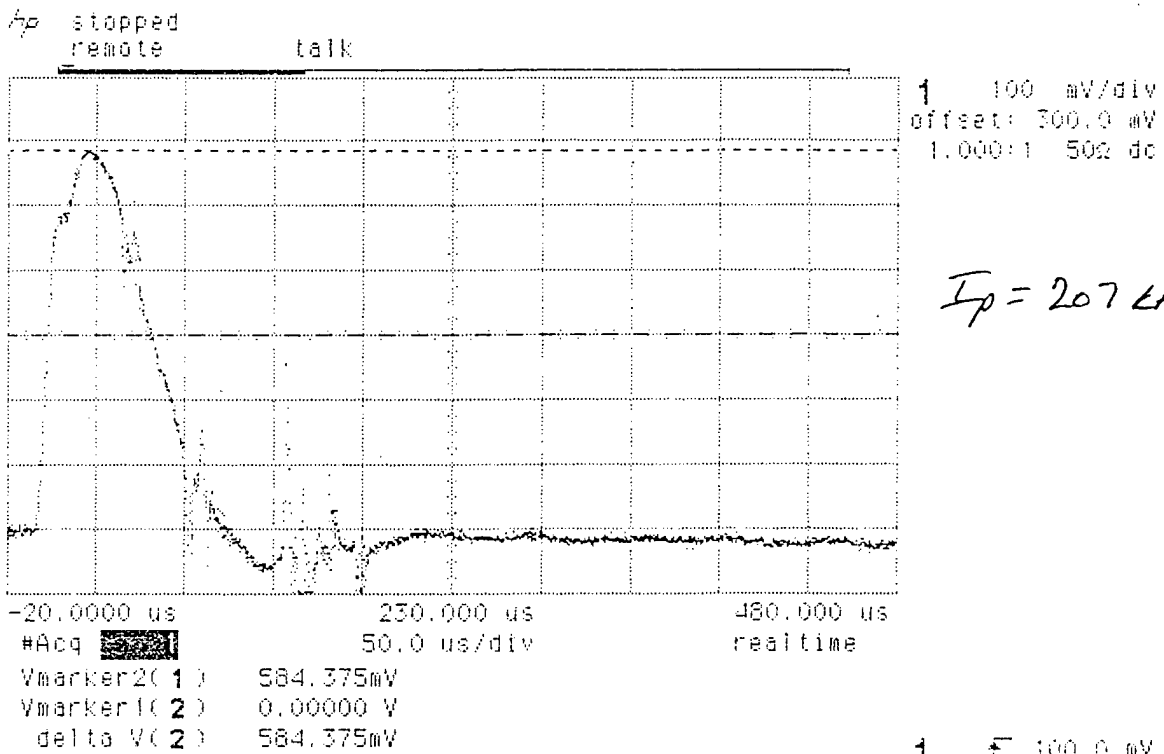

| | Sensitivity | Offset | Probe | Coupling | Impedance |
|-----------|-------------|------------|-------|----------|-----------|
| Channel 1 | 100 mV/div | 300.000 mV | 1:1 | dc | 50 ohm |

Trigger Mode: Edge
 On the Positive Edge of Channel 1
 Trigger Level(s)
 Channel 1 = 100,000 mV (noise reject OFF)
 HoldOff = 40.000 n/s

Figure C-7. Measurement of Component A Waveform on Panel Q11#6.

Filename: S1Q11#8A.RAW
 Date: 01-17-1995
 Time: 15:09:42

$$\text{Action Integral(Channel 1)} = 1.501047\text{E-}05 (708)^2 (500\text{A}/\mu)^2 = 1.88 \text{ E6 A}^2\text{.sec}$$

Quick-Look Plot from HP54510A
 GPIBaddress 07 Channel 1

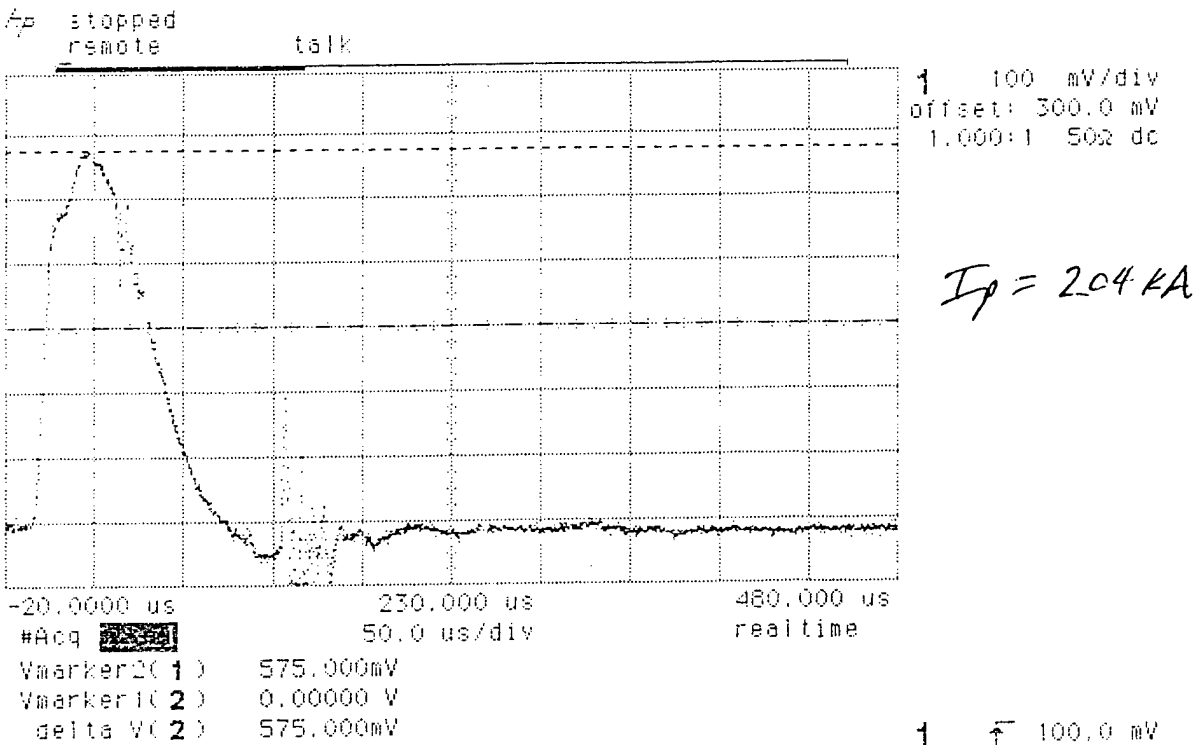

| | Sensitivity | Offset | Probe | Coupling | Impedance |
|-----------|-------------|------------|-------|----------|-----------|
| Channel 1 | 100 mV/div | 300.000 mV | 1:1 | dc | 50 ohm |

Trigger Mode: Edge
 On the Positive Edge of Channel 1
 Trigger Level(s)
 Channel 1 = 100,000 mV (noise reject OFF)
 HoldOff = 40.000 n/s

Figure C-8. Measurement of Component A Waveform on Panel Q11#8.

Filename: S1Q11#9A.RAW
 Date: 01-17-1995
 Time: 15:23:49

Action Integral(Channel 1) = $1.472124E-05 (708)^2 (500 A/\mu)^2 = 1.84 E6 A^2 \cdot sec$

Quick-Look Plot from HP54510A
 GPIBAddress 07 Channel 1

sp stopped
 remote tsik

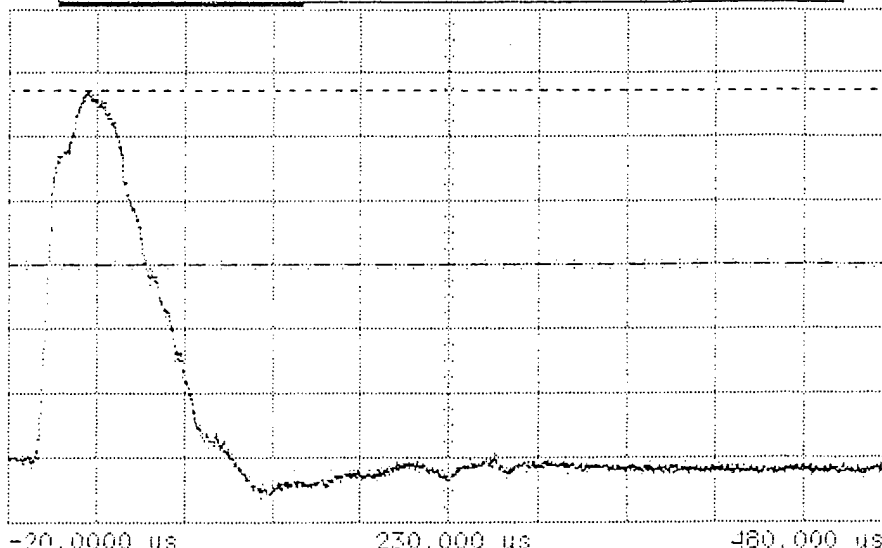

1 100 mV/div
 offset: 300.0 mV
 1.000:1 500 dc

$I_p = 702 \text{ KA}$

-20.0000 us 230.000 us 480.000 us
 #Acq [] 50.0 us/div realtime
 Vmarker2(1) 571.875mV
 Vmarker1(2) 0.00000 V
 delta V(2) 571.875mV

1 100.0 mV

| | Sensitivity | Offset | Probe | Coupling | Impedance |
|-----------|-------------|------------|-------|----------|-----------|
| Channel 1 | 100 mV/div | 300.000 mV | 1:1 | dc | 50 ohm |

Trigger Mode: Edge
 On the Positive Edge of Channel 1
 Trigger Level(s)
 Channel 1 = 100,000 mV (noise reject OFF)
 HoldOff = 40.000 n/s

Figure C-9. Measurement of Component A Waveform on Panel Q11#9.

Filename: SRBCALB1.RAW
 Date: 01-18-1995
 Time: 08:24:51

Action Integral(Channel 1) = ~~1.731501E-04~~

Quick-Look Plot from HP54510A
 GPIBaddress 07 Channel 1

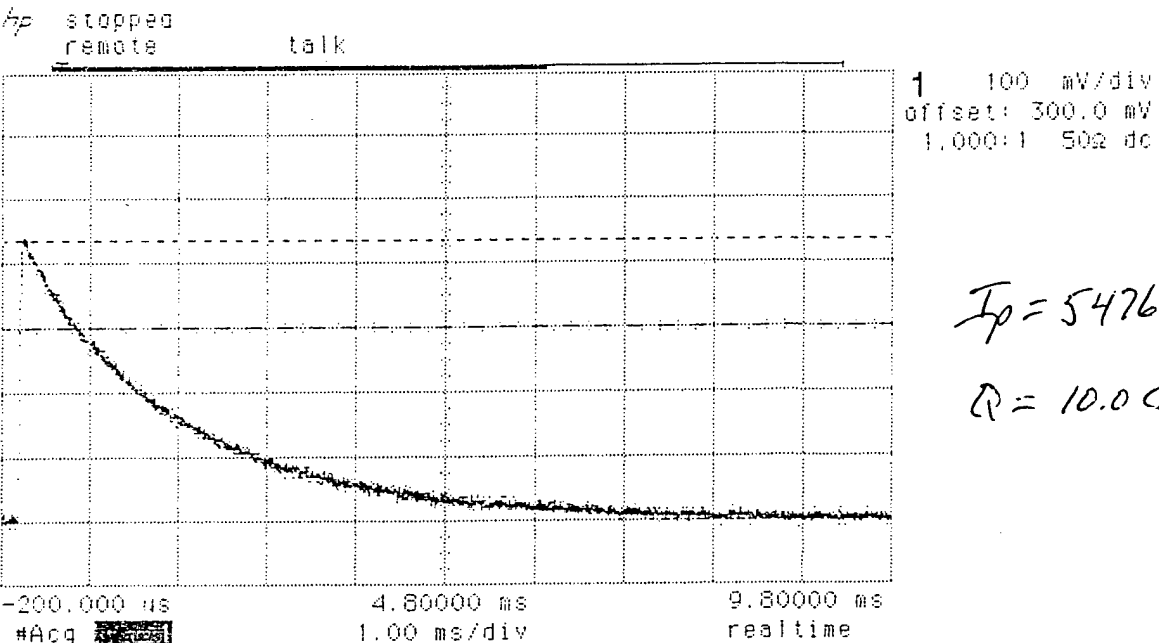

#Acq ████████
 Vmarker2(1) 434.375mV
 Vmarker1(2) 0.00000 V
 delta V(2) 434.375mV

1 \int 100.0 mV

| Channel 1 | Sensitivity | Offset | Probe | Coupling | Impedance |
|-----------|-------------|------------|-------|----------|-----------|
| | 100 mV/div | 300.000 mV | 1:1 | dc | 50 ohm |

Trigger Mode: Edge
 On the Positive Edge of Channel 1
 Trigger Level(s)
 Channel 1 = 100,000 mV (noise reject OFF)
 HoldOff = 40.000 n/s

Figure C-10. Measurement of Component B Calibration Waveform on the Frustum Panel.

Filename: SRBCALB2.RAW
 Date: 01-18-1995
 Time: 08:54:49

Action Integral(Channel 1) = ~~1.5123 A~~

Quick-Look Plot from HP54510A
 GPIBaddress 07 Channel 1

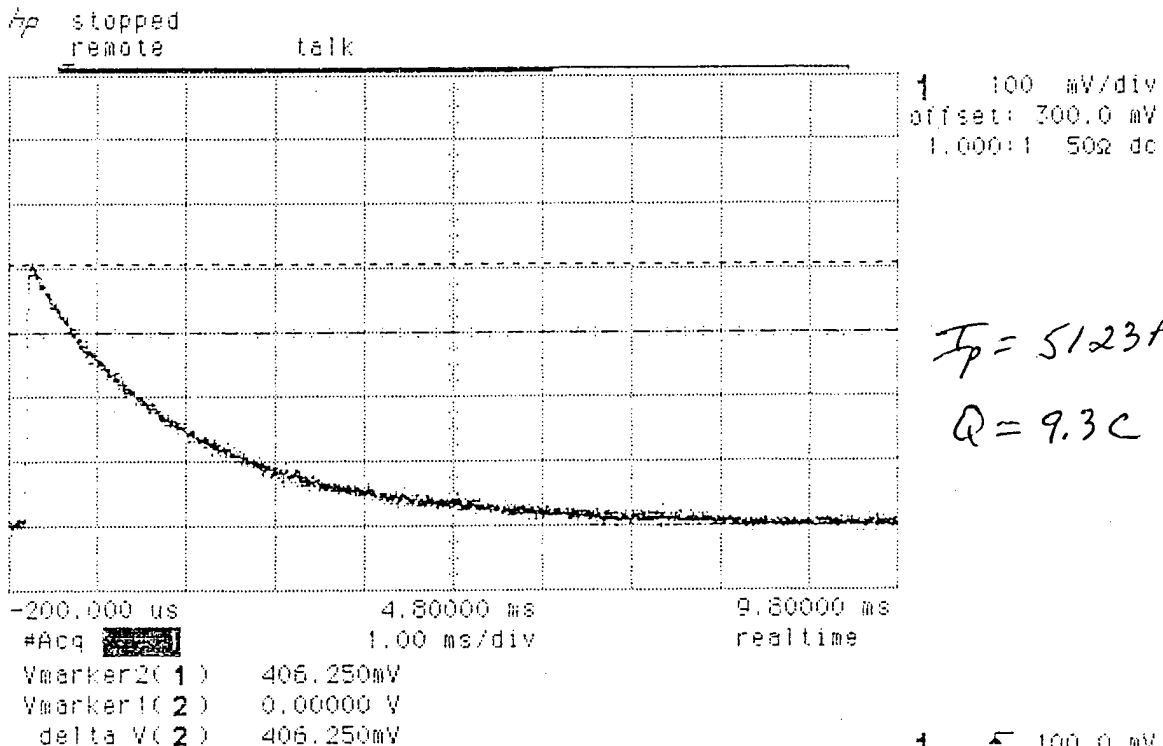

1 5 100.0 mV

| Channel 1 | Sensitivity | Offset | Probe | Coupling | Impedance |
|-----------|-------------|------------|-------|----------|-----------|
| Channel 1 | 100 mV/div | 300.000 mV | 1:1 | dc | 50 ohm |

Trigger Mode: Edge
 On the Positive Edge of Channel 1
 Trigger Level(s)
 Channel 1 = 100,000 mV (noise reject OFF)
 HoldOff = 40.000 n/s

Figure C-11. Measurement of Component B Calibration Waveform on the Aft Skirt Panel.

Filename: SS106#9B.RAW
 Date: 01-18-1985
 Time: 09:05:24

Action Integral(Channel 1) = ~~1.207757E 04~~

Quick-Look Plot from HP54510A
 GPIBaddress 07 Channel 1

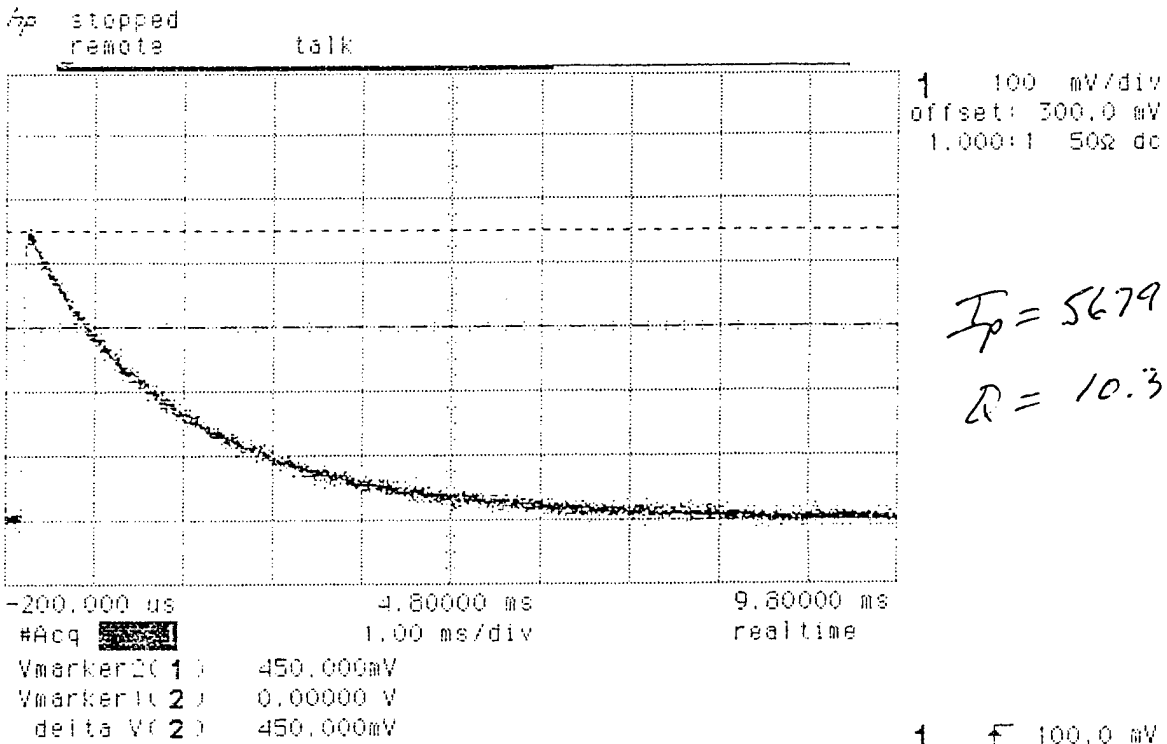

| Channel 1 | Sensitivity | Offset | Probe | Coupling | Impedance |
|-----------|-------------|------------|-------|----------|-----------|
| | 100 mV/div | 300.000 mV | 1:1 | dc | 50 ohm |

Trigger Mode: Edge
 On the Positive Edge of Channel 1
 Trigger Level(s)
 Channel 1 = 100,000 mV (noise reject OFF)
 HoldOff = 40.000 n/s

Figure C-12. Measurement of Component B Waveform on Panel Q6#9.

Filename: S106#10B.RAW
Date: 01-18-1995
Time: 09:16:50

Action Integral(Channel 1) = ~~1.000000~~

Quick-Look Plot from HP54510A
GPIBaddress 07 Channel 1

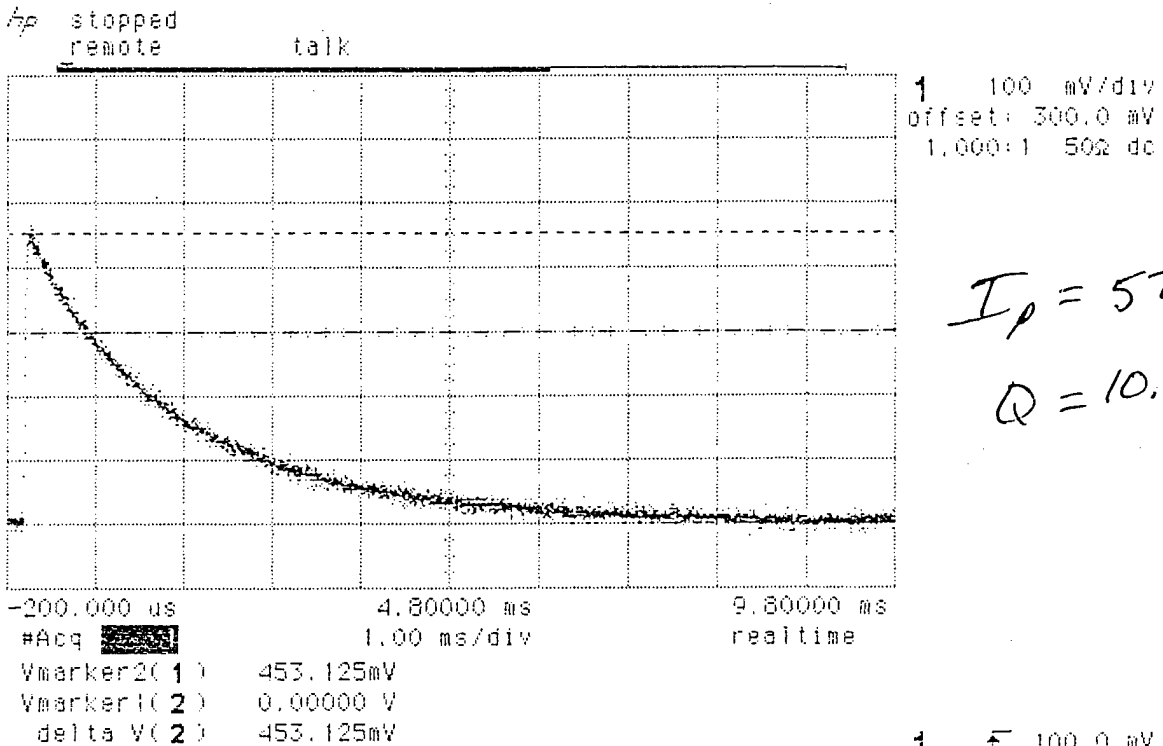

| Channel 1 | Sensitivity | Offset | Probe | Coupling | Impedance |
|-----------|-------------|------------|-------|----------|-----------|
| | 100 mV/div | 300.000 mV | 1:1 | dc | 50 ohm |

Trigger Mode: Edge
On the Positive Edge of Channel 1
Trigger Level(s)
Channel 1 = 100,000 mV (noise reject OFF)
HoldOff = 40.000 n/s

Figure C-13. Measurement of Component B Waveform on Panel Q6#10.

Filename: S1Q13#2B.RAW
 Date: 01-18-1995
 Time: 09:27:43

Action Integral(Channel 1) = ~~1.75~~ 04

Quick-Look Plot from HP54510A
 GPIBaddress 07 Channel 1

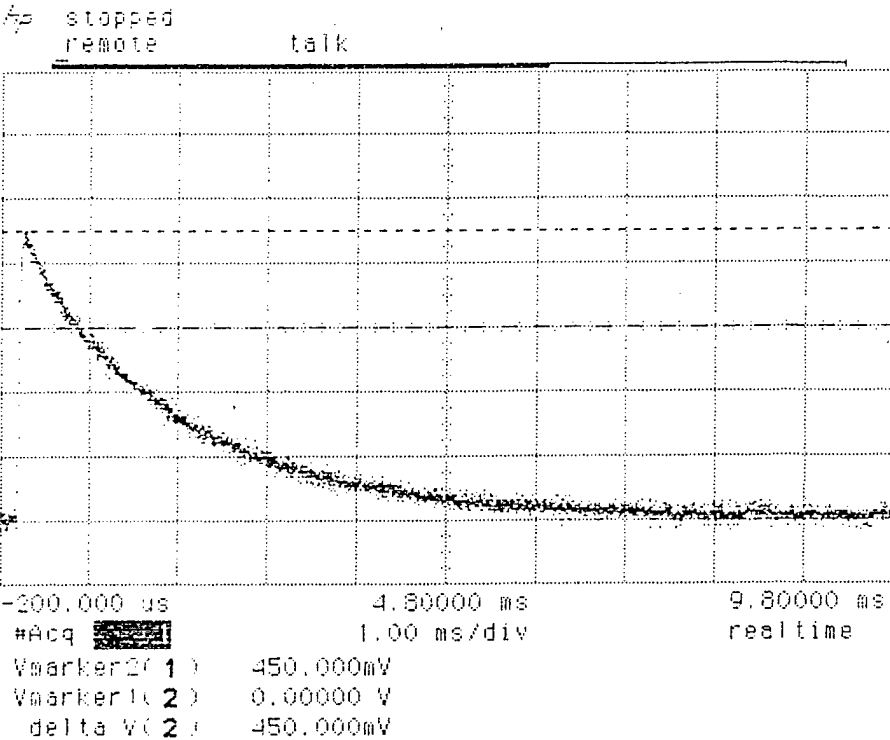

1 100 mV/div
 offset: 300.0 mV
 1.000:1 50 ohm dc

$I_p = 5679 A$
 $R = 10.3 \Omega$

1 5 100.0 mV

| | Sensitivity | Offset | Probe | Coupling | Impedance |
|-----------|-------------|------------|-------|----------|-----------|
| Channel 1 | 100 mV/div | 300.000 mV | 1:1 | dc | 50 ohm |

Trigger Mode: Edge
 On the Positive Edge of Channel 1
 Trigger Level(s)
 Channel 1 = 100,000 mV (noise reject OFF)
 HoldOff = 40.000 n/s

Figure C-14. Measurement of Component B Waveform on Panel Q13#2.

Filename: S1Q11#6B.RAW
 Date: 01-18-1995
 Time: 09:37:29

Action Integral(Channel 1) = ~~1.592775E-04~~

Quick-Look Plot from HPS4510A
 GPIBaddress 07 Channel 1

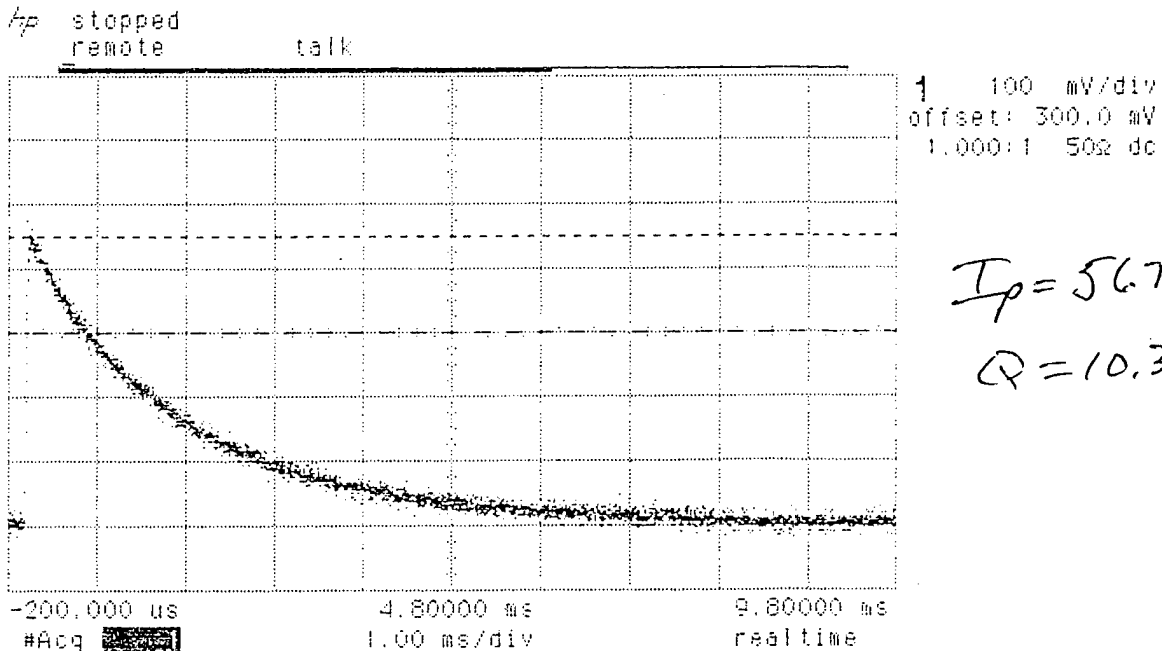

Vmarker2(1) 450.000mV
 Vmarker1(2) 0.00000 V
 delta V(2) 450.000mV

1 100.0 mV

| Channel | Sensitivity | Offset | Probe | Coupling | Impedance |
|-----------|-------------|------------|-------|----------|-----------|
| Channel 1 | 100 mV/div | 300.000 mV | 1:1 | dc | 50 ohm |

Trigger Mode: Edge
 On the Positive Edge of Channel 1
 Trigger Level(s)
 Channel 1 = 100,000 mV (noise reject OFF)
 HoldOff = 40.000 n/s

Figure C-15. Measurement of Component B Waveform on Panel Q11#6.

Filename: S1Q11#8B.RAW
 Date: 01-18-1995
 Time: 09:46:07

Action Integral(Channel 1) = ~~1.000000E-04~~

Quick-Look Plot from HP54510A
 GPIBaddress 07 Channel 1

stopped
 remote talk

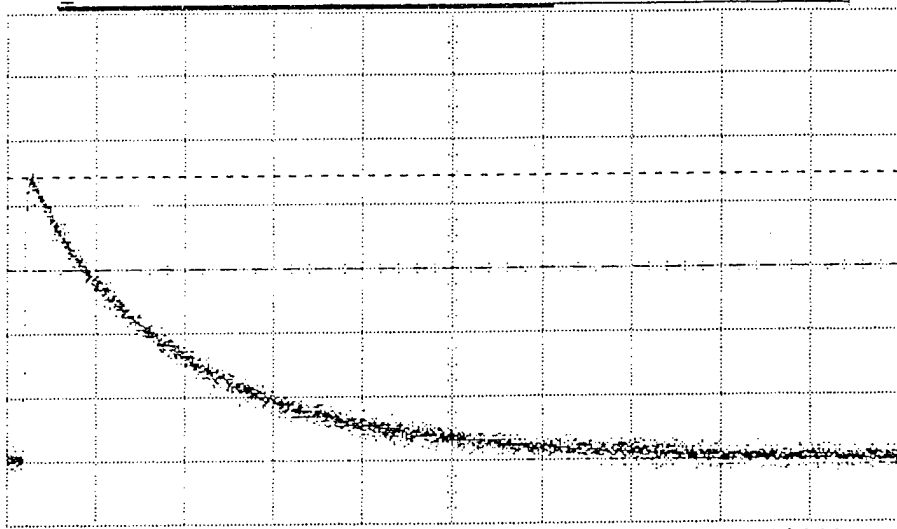

1 100 mV/div
 offset: 300.0 mV
 1.000:1 50Ω dc

$I_p = 5603A$
 $R = 10.1C$

-200.000 us 4.80000 ms 9.80000 ms
 #Acq [] 1.00 ms/div realtime

Vmarker2(1) 443.750mV
 Vmarker1(2) 0.00000 V
 delta V(2) 443.750mV

1 100.0 mV

| Channel 1 | Sensitivity | Offset | Probe | Coupling | Impedance |
|-----------|-------------|------------|-------|----------|-----------|
| | 100 mV/div | 300.000 mV | 1:1 | dc | 50 ohm |

Trigger Mode: Edge
 On the Positive Edge of Channel 1
 Trigger Level(s)
 Channel 1 = 100,000 mV (noise reject OFF)
 HoldOff = 40.000 n/s

Figure C-16. Measurement of Component B Waveform on Panel Q11#8.

Filename: SIQ11#9B.RAW
 Date: 01-18-1995
 Time: 09:54:00

Action Integral(Channel 1) = ~~1.775103E-04~~

Quick-Look Plot from HPS4510A
 GPIBaddress 07 Channel 1

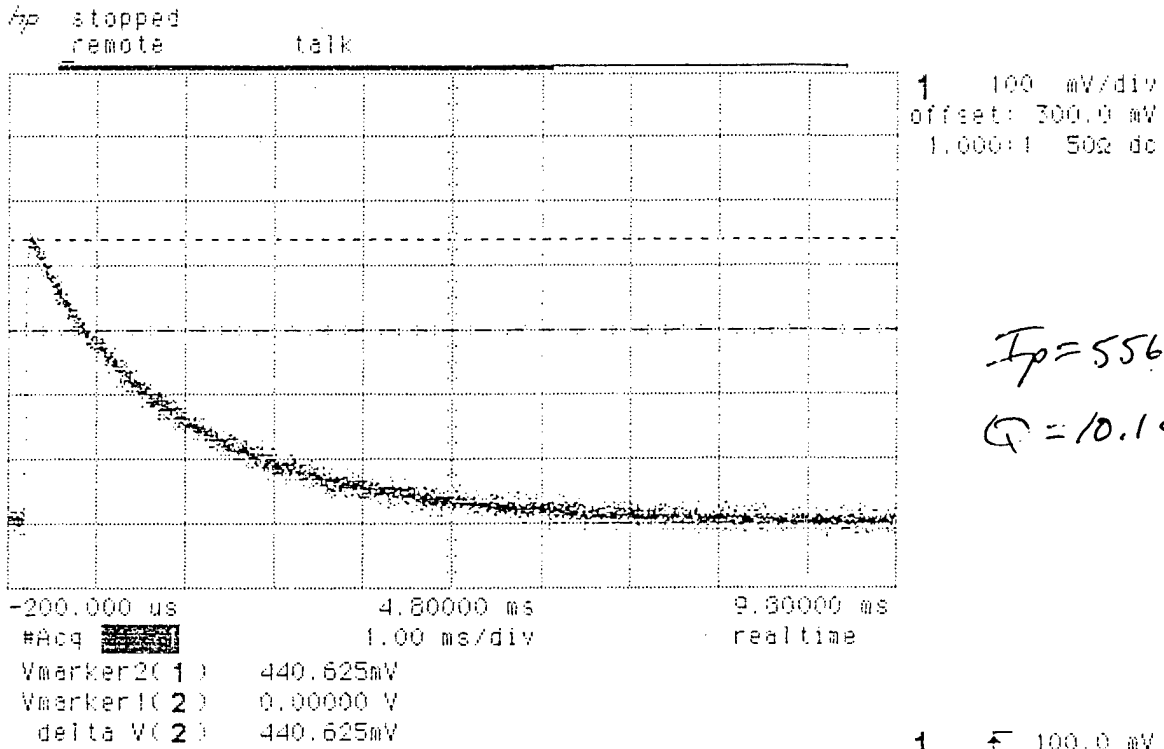

| | Sensitivity | Offset | Probe | Coupling | Impedance |
|-----------|-------------|------------|-------|----------|-----------|
| Channel 1 | 100 mV/div | 300.000 mV | 1:1 | dc | 50 ohm |

Trigger Mode: Edge
 On the Positive Edge of Channel 1
 Trigger Level(s)
 Channel 1 = 100,000 mV (noise reject OFF)
 HoldOff = 40.000 n/s

Figure C-17. Measurement of Component B Waveform on Panel Q11#9.

Filename: SRBCALC1.RAW
Date: 01-18-1995
Time: 13:41:13

Action Integral(Channel 1) = ~~2122201~~

Charge Integral(Channel 1) = .7503593 (20)(13.16 A/V) = 200.1 C

Quick-Look Plot from HP54200A
GPIBaddress 11 Channel 1

Channel **1** ----- Status: Acquisition Complete
LLO MTA
Range **1.0 V** Auto Scale **Disabled**
Offset **0.000 V** Store Mode **Normal**
Coupling **DC**

Graph **1** 375 mV/div 1.00 V 200 ms/div -200.0 ms

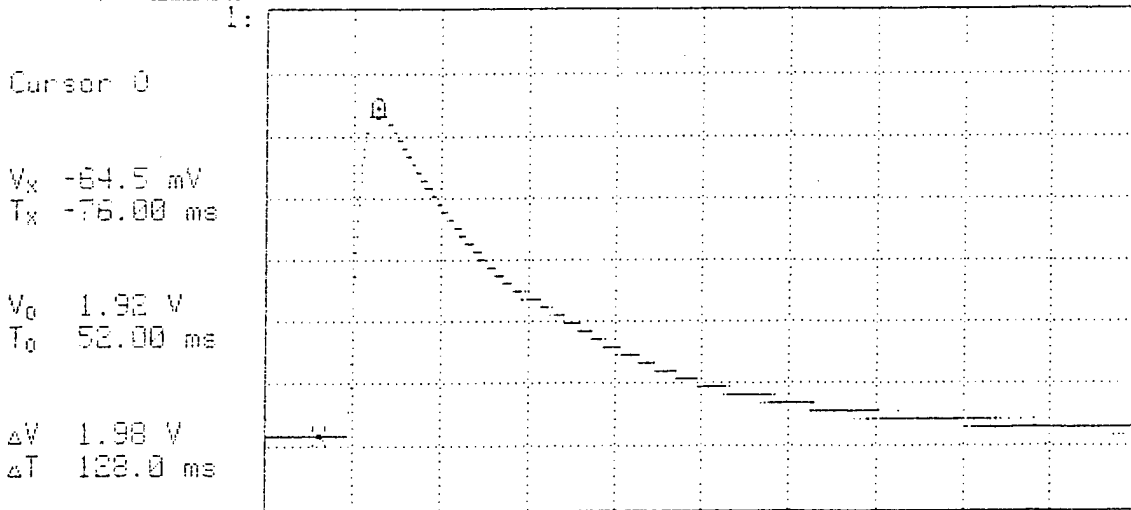

$$I_p = 521 A$$

Figure C-18. Measurement of Component C Calibration waveform on the Frustum Panel.

Filename: SS206#90.RAW
Date: 01-18-1995
Time: 15:08:37

Action Integral(Channel 1) = ~~.8100000~~

Charge Integral(Channel 1) = $.7709062(20)(13.16A/V) = 203 C$

Quick-Look Plot from HP54200A
GPIBAddress 11 Channel 1

Channel Status: Acquisition Complete
LLO MTA
Range Auto Scale
Offset Store Mode
Coupling

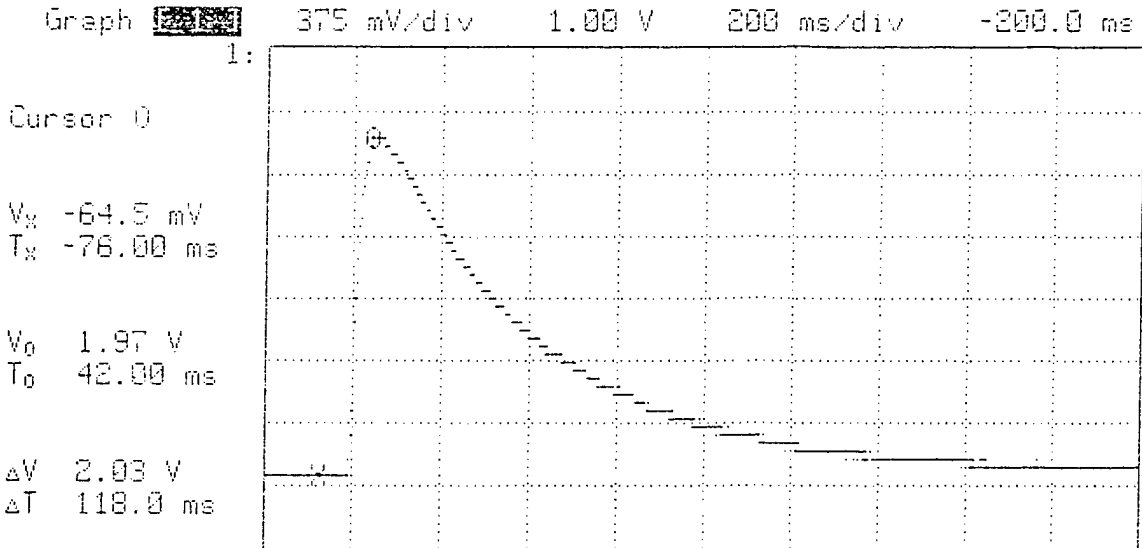

$$I_p = 534 A$$

Figure C-20. Measurement of Component C Waveform on Panel Q6#9.

Filename: SIQ6#10C.RAW
Date: 01-18-1995
Time: 15:24:49

Action Integral(Channel 1) = ~~0.774863~~

Charge Integral(Channel 1) = $.774863 (20)(13.16 \text{ A/V}) = 204 \text{ C}$

Quick-Lock Plot from HP54200A
GPIBAddress 11 Channel 1

Channel ~~1~~ ----- Status: Acquisition Complete
LLQ NTA SHIFT

Range ~~2.00 V~~
Offset ~~0.000 V~~

Auto Scale ~~Disabled~~
Store Mode ~~Normal~~
Coupling ~~DC~~

Graph ~~1~~ 375 mV/div 1.00 V 200 ms/div -200.0 ms

Cursor 0

V_x -64.5 mV
T_x -76.00 ms

V₀ 1.97 V
T₀ 54.00 ms

ΔV 2.03 V
 ΔT 130.0 ms

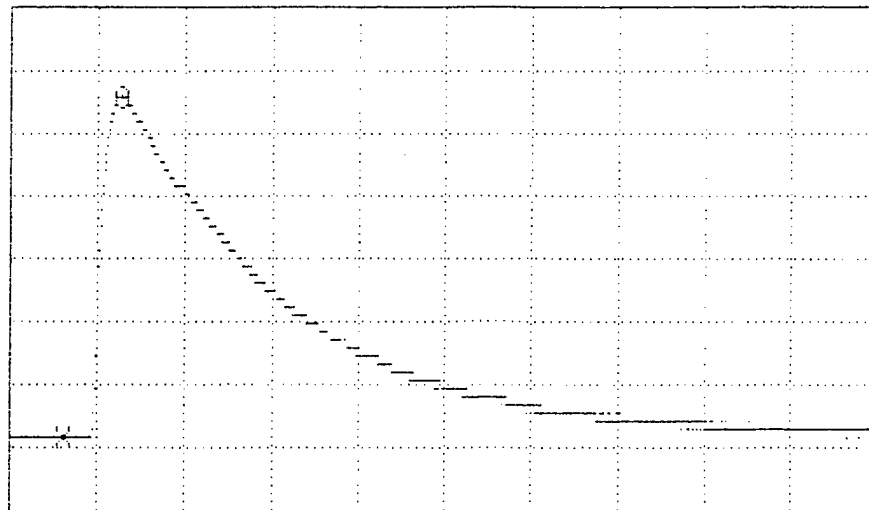

$$I_p = 534 \text{ A}$$

Figure C-21. Measurement of Component C Waveform on panel Q6#10.

Filename: S1013#2C.RAW
Date: 01-18-1995
Time: 15:45:55

Action Integral(Channel 1) = ~~.8204105~~

Charge Integral(Channel 1) = .774196 (20)(13.16 A/V) = 204 C

Quick-Look Plot from HP54200A
GPIBAddress 11 Channel 1

Channel Status: Acquisition Complete
LLO MTA

Range Auto Scale Disabled
Offset Store Mode Normal
Coupling

Graph 375 mV/div 1.00 V 200 ms/div -200.0 ms

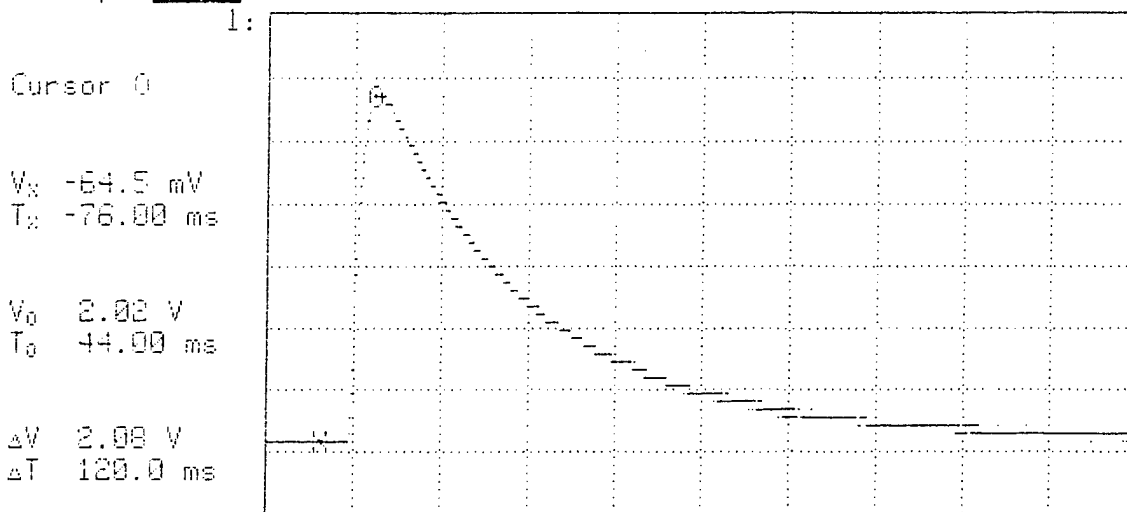

$$I_p = 547A$$

Figure C-22. Measurement of Component C Waveform on Panel Q13#2.

Filename: SIQ11#6C.RAW
Date: 01-18-1995
Time: 15:51:24

Action Integral(Channel 1) = ~~0.000000~~

Charge Integral(Channel 1) = .7848396 (20)(13.16 A/u) = 207C

Quick-Look Plot from HP54200A
 GPIBAddress 11 Channel 1

Channel 1 ----- Status: Acquisition Complete -----
 LLO MTA

Range 2.0 V
Offset 0.000 V

Auto Scale Disabled
Store Mode Normal
Coupling DC

Graph 1: 375 mV/div 1.00 V 200 ms/div -200.0 ms

Cursor 0

V_x -64.5 mV
T_x -76.00 ms

V₀ 1.97 V
T₀ 50.00 ms

ΔV 2.03 V
ΔT 126.0 ms

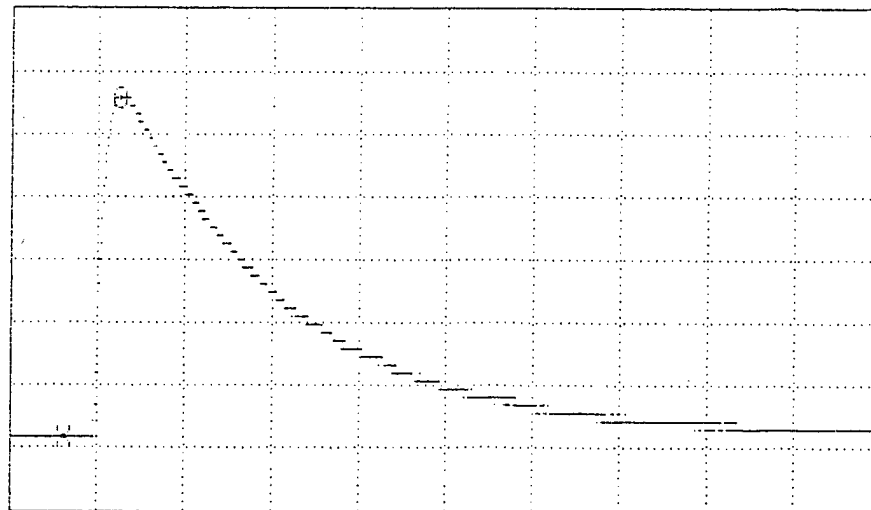

$$I_p = 534 A$$

Figure C-23. Measurement of Component C Waveform on Panel Q11#6.

Filename: SIQ11#⁸C.RAW
 Date: 01-18-1995
 Time: 16:05:15

Action Integral(Channel 1) = ~~0.7560051~~

Charge Integral(Channel 1) = 0.7560051 (20) (13.16 A/V) = 199C

Quick-Look Plot from HP54200A
 GPIBAddress 11 Channel 1

Channel Status: Acquisition Complete
 LLO MTR

Range 2.00 V
 Offset 0.00 V

Auto Scale Disabled
 Store Mode Normal
 Coupling GND AC

Graph 375 mV/div 1.00 V 200 ms/div -200.0 ms

Cursor 0

V_x -54.5 mV
 T_x -75.00 ms

V₀ 1.37 V
 T₀ 48.00 ms

ΔV 2.03 V
 ΔT 124.0 ms

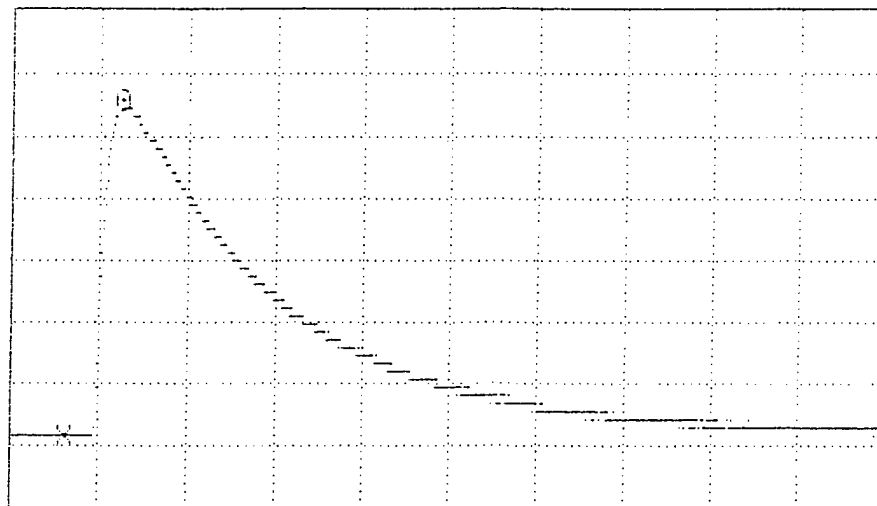

$I_p = 534 A$

Figure C-24. Measurement of Component C Waveform on Panel Q11#8.

Filename: S2011#90.RAW
Date: 01-18-1995
Time: 16:20:15

Action Integral(Channel 1) = ~~2245514~~

Charge Integral(Channel 1) = .7894548 (20)(13.16 A/μ) = 203 C

Quick-Look Plot from HPS4200A
GPIBAddress 11 Channel 1

Channel 1 ----- Status: Acquisition Complete
LLO NTA
Range 3.0 V Auto Scale Disabled
Offset 15.000 V Store Mode Normal
Coupling DC AC

Graph 1: 375 mV/div 1.00 V 200 ms/div -200.0 ms

Cursor 0

V₁ -64.5 mV
T₁ -76.00 ms

V₀ 2.02 V
T₀ 44.00 ms

ΔV 2.08 V
ΔT 120.0 ms

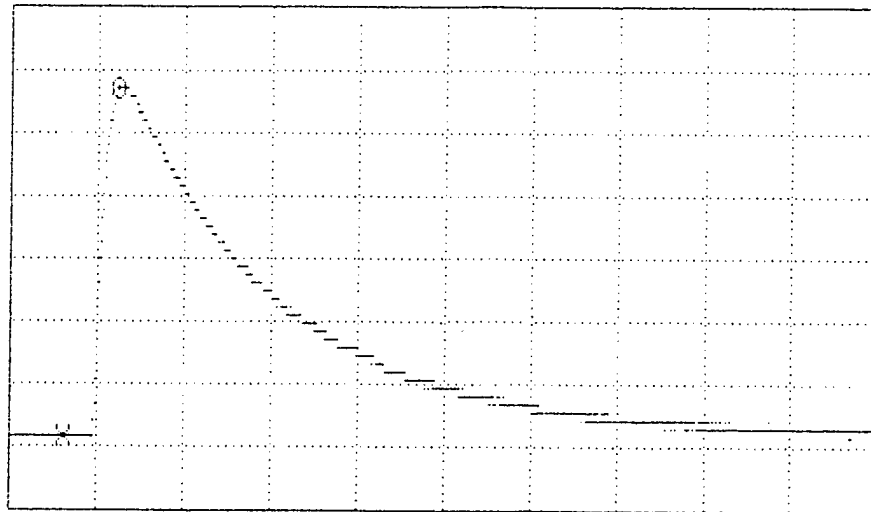

$$I_p = 547A$$

Figure C-25. Measurement of Component C Waveform on Panel Q11#9.

Filename: SRBCALD1.RAW
 Date: 01-20-1995
 Time: 13:14:54

Action Integral(Channel 1) = $4.916749E-06 (400 \text{ A/V})^2 (708)^2 = 0.39 \times 10^6 \text{ A}^2 \cdot \text{s}$

Quick-Look Plot from HP54510A
 GPIBaddress 07 Channel 1

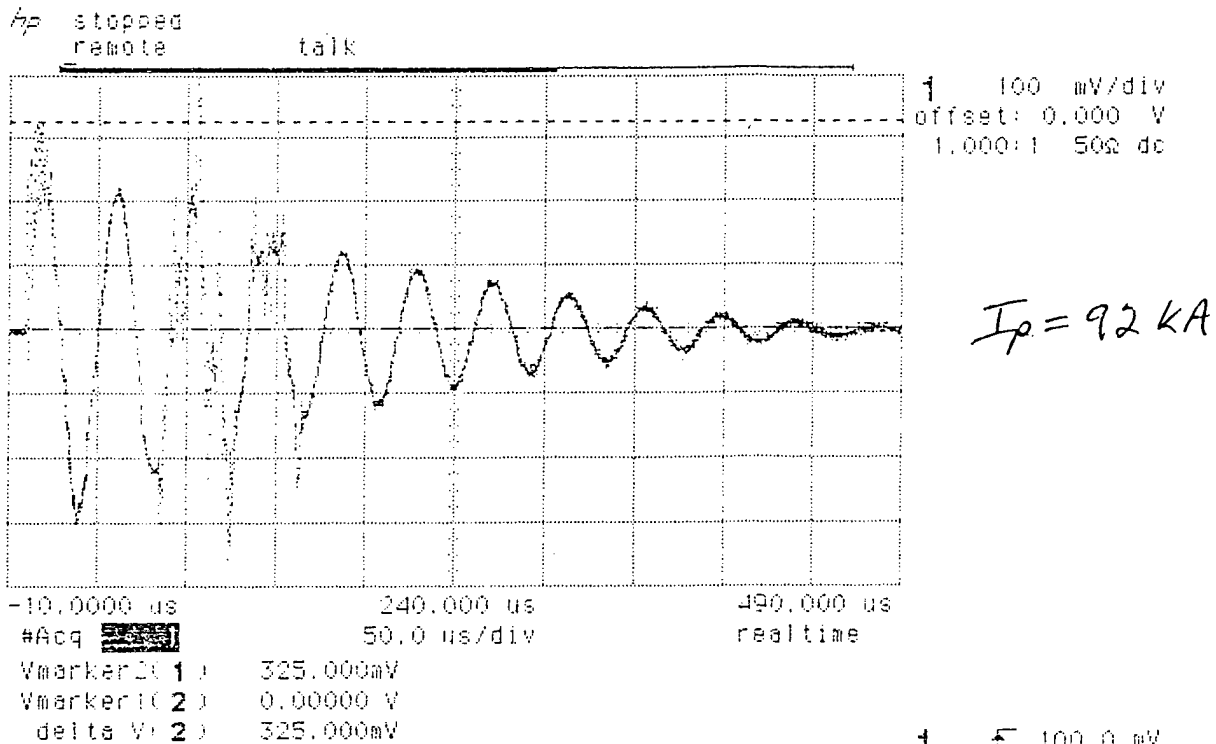

| Channel 1 | Sensitivity | Offset | Probe | Coupling | Impedance |
|-----------|-------------|-----------|-------|----------|-----------|
| | 100 mV/div | 0.00000 V | 1:1 | dc | 50 ohm |

Trigger Mode: Edge
 On the Positive Edge of Channel 1
 Trigger Level(s)
 Channel 1 = 100.000 mV (noise reject OFF)
 HoldOff = 40.000 ns

Figure C-26. Measurement of Component D Calibration Waveform on the Frustum Panel.

Filename: SRBCALD2.RAW
 Date: 01-20-1995
 Time: 13:32:44

Action Integral(Channel 1) = $4.379138E-06 (400A/\mu)^2 (70\mu)^2 = 0.35 \times 10^6 A^2 \cdot s$

Quick-Look Plot from HP54510A
 GPIBaddress 07 Channel 1

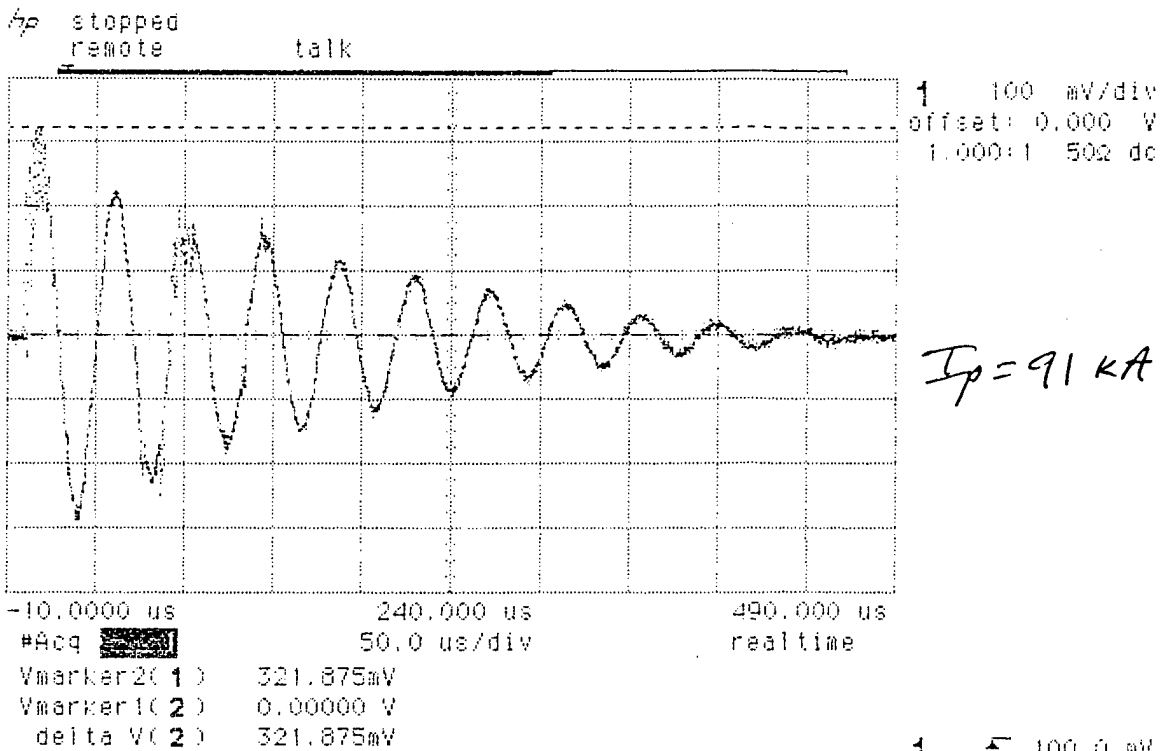

| Channel 1 | Sensitivity | Offset | Probe | Coupling | Impedance |
|-----------|-------------|-----------|-------|----------|-----------|
| | 100 mV/div | 0.00000 V | 1:1 | dc | 50 ohm |

Trigger Mode: Edge
 On the Positive Edge of Channel1
 Trigger Level(s)
 Channel1 = 100.000 mV (noise reject OFF)
 HoldOff = 40.000 ns

Figure C-27. Measurement of Component D Calibration Waveform on the Aft Skirt Panel.

Filename: 89106#90.RAW
 Date: 01-20-1995
 Time: 13:40:27

Action Integral(Channel 1) = $4.869863E-06 (400 \text{ A/V})^2 (208)^2 = 0.39 \times 10^6 \text{ A}^2$

Quick-Look Plot from HP54510A
 GPIBaddress 07 Channel 1

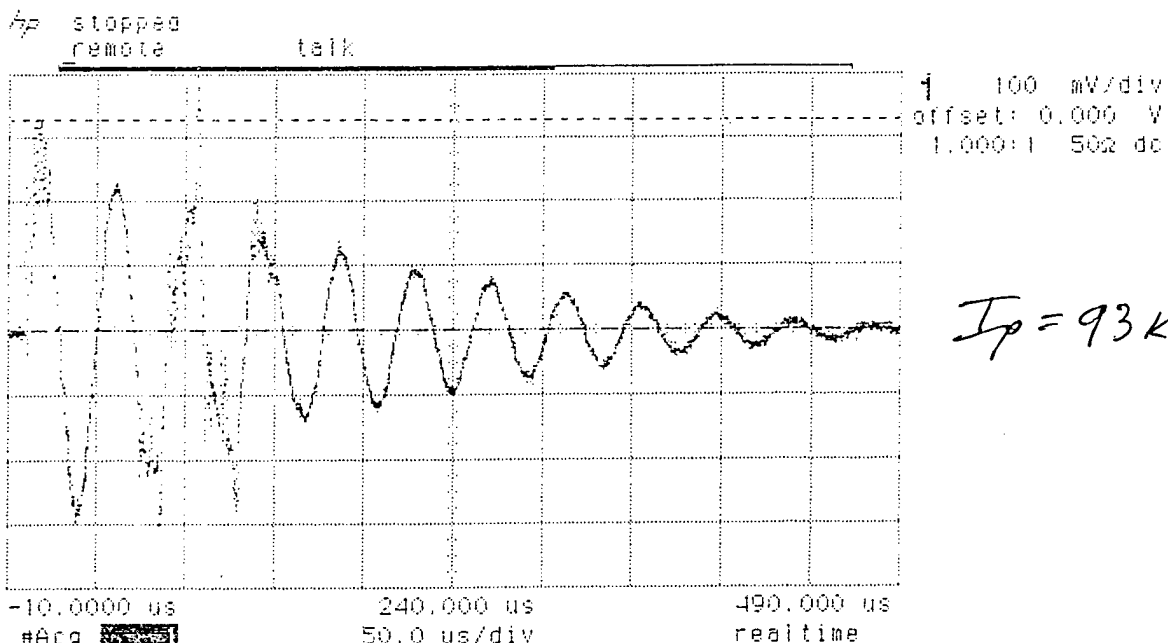

$I_p = 93 \text{ kA}$

Vmarker2(1) 328.125mV
 Vmarker1(2) 0.00000 V
 delta V(2) 328.125mV

1 100.0 mV

| | Sensitivity | Offset | Probe | Coupling | Impedance |
|-----------|-------------|-----------|-------|----------|-----------|
| Channel 1 | 100 mV/div | 0.00000 V | 1:1 | dc | 50 ohm |

Trigger Mode: Edge
 On the Positive Edge of Channel1
 Trigger Level(s)
 Channel1 = 100.000 mV (noise reject OFF)
 HoldOff = 40.000 ns

Figure C-28. Measurement of Component D Waveform on Panel Q6#9.

Filename: S1Q6#100.RAW
 Date: 01-20-1995
 Time: 13:51:08

Action Integral(Channel 1) = $5.324274E-06 (400A/\mu)^2 (708)^2 = 0.42 \times 10^6 A^2 \cdot s$

Quick-Look Plot from HP54510A
 GPIBAddress 07 Channel 1

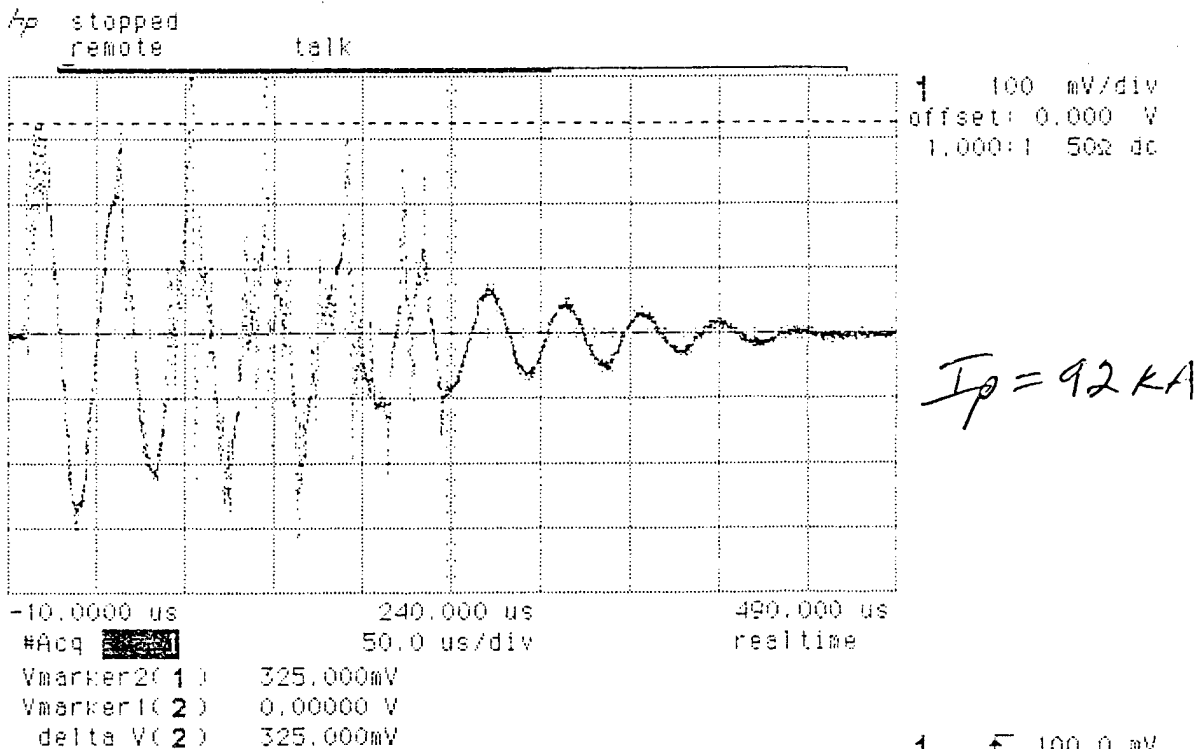

| Channel 1 | Sensitivity | Offset | Probe | Coupling | Impedance |
|-----------|-------------|-----------|-------|----------|-----------|
| Channel 1 | 100 mV/div | 0.00000 V | 1:1 | dc | 50 ohm |

Trigger Mode: Edge
 On the Positive Edge of Channel1
 Trigger Level(s)
 Channel1 = 100.000 mV (noise reject OFF)
 HoldOff = 40.000 ns

Figure C-29. Measurement of Component D Waveform on Panel Q6#10.

Filename: S1Q13#2D.RAW
 Date: 01-20-1995
 Time: 14:02:05

Action Integral(Channel 1) = $5.029919E-06 (400 \text{ A/V})^2 (708)^2 = 0.40 \times 10^6 \text{ A}^2$

Quick-Look Plot from HP54510A
 GPIBAddress 07 Channel 1.

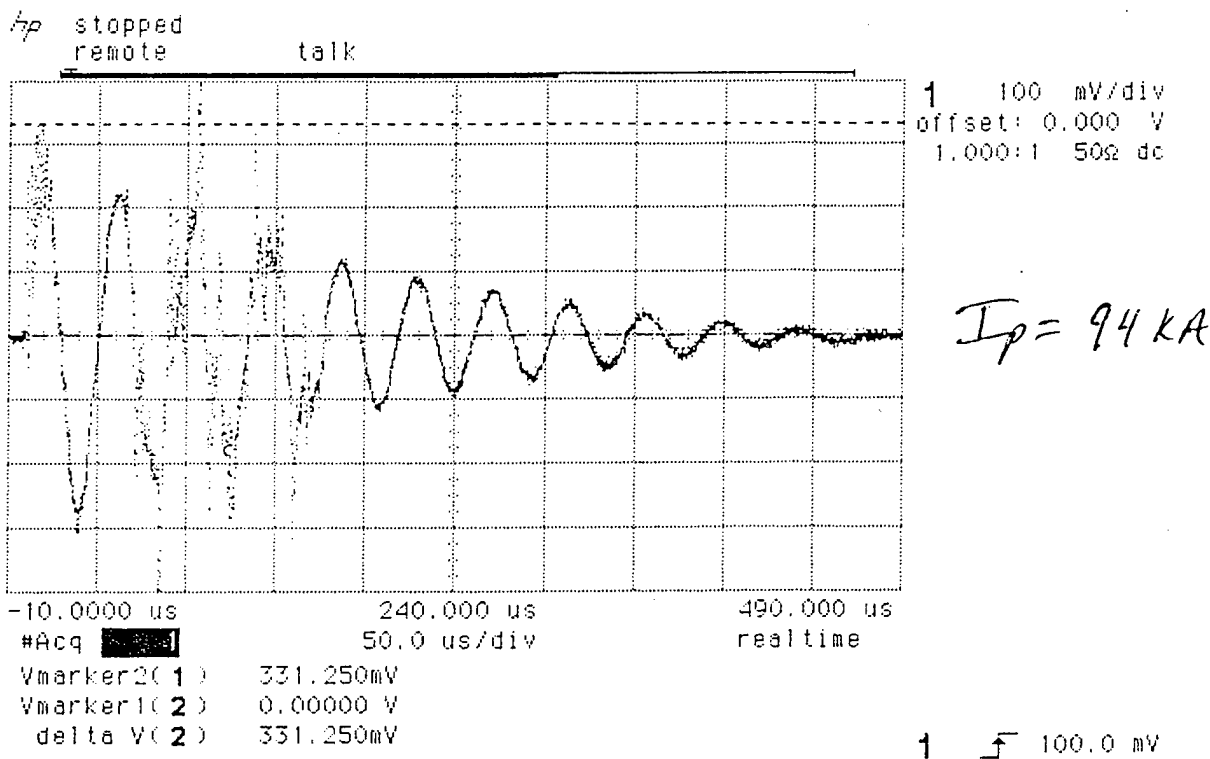

| Channel 1 | Sensitivity | Offset | Probe | Coupling | Impedance |
|-----------|-------------|-----------|-------|----------|-----------|
| | 100 mV/div | 0.00000 V | 1:1 | dc | 50 ohm |

Trigger Mode: Edge
 On the Positive Edge of Channel 1
 Trigger Level(s)
 Channel 1 = 100.000 mV (noise reject OFF)
 HoldOff = 40.000 ns

Figure C-30. Measurement of Component D Waveform on Panel Q13#2.

Filename: S1Q11#6D.RAW
 Date: 01-20-1995
 Time: 14:12:13

$$\text{Action Integral(Channel 1)} = 4.319782\text{E-}06 (400 \text{ A}/\mu)^2 (708)^2 = 0,35 \times 10^6 \text{ A}^2 \cdot \text{sc}$$

Quick-Look Plot from HP54510A
 GPIBaddress 07 Channel 1

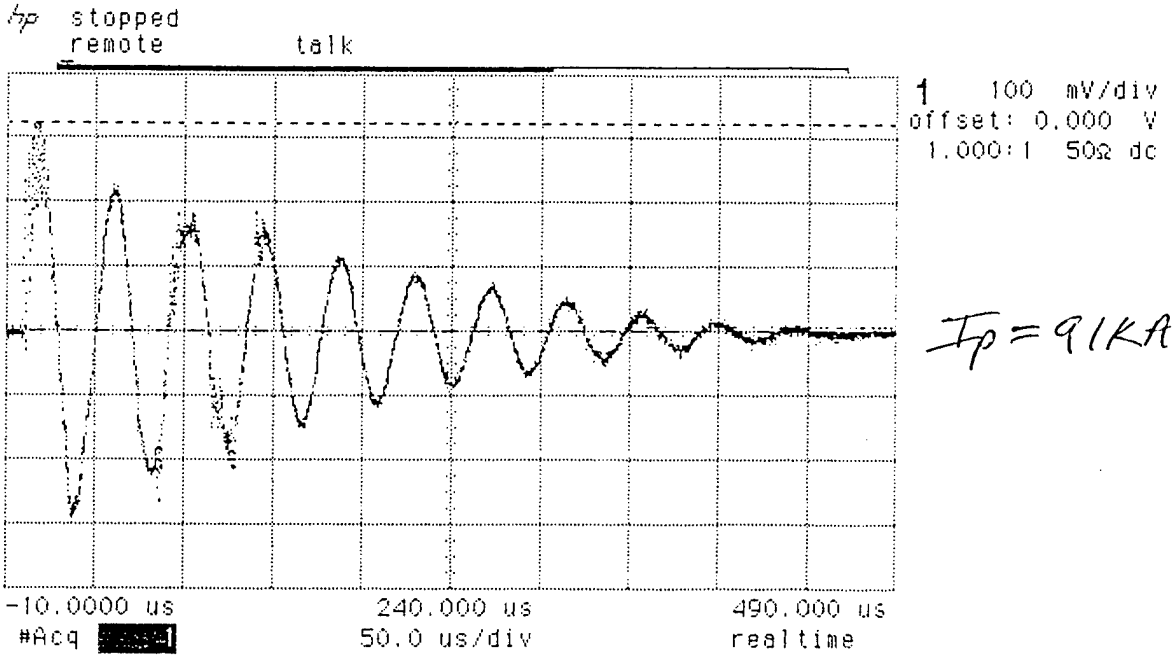

Vmarker2(1) 321.875mV
 Vmarker1(2) 0.00000 V
 delta V(2) 321.875mV

1 100.0 mV

| Channel 1 | Sensitivity | Offset | Probe | Coupling | Impedance |
|-----------|-------------|-----------|-------|----------|-----------|
| Channel 1 | 100 mV/div | 0.00000 V | 1:1 | dc | 50 ohm |

Trigger Mode: Edge
 On the Positive Edge of Channel1
 Trigger Level(s)
 Channel1 = 100.000 mV (noise reject OFF)
 HoldOff = 40.000 ns

Figure C-31. Measurement of Component D Waveform on Panel Q11#6.

Filename: SIQ11#8D.RAW
 Date: 01-20-1995
 Time: 14:21:55

$$\text{Action Integral(Channel 1)} = 4.840104\text{E-}06 (400 \text{ A/V})^2 (908)^2 = 0.39 \times 10^6 \text{ A}^2 \cdot \text{sec}$$

Quick-Look Plot from HP54510A
 GPIBAddress 07 Channel 1

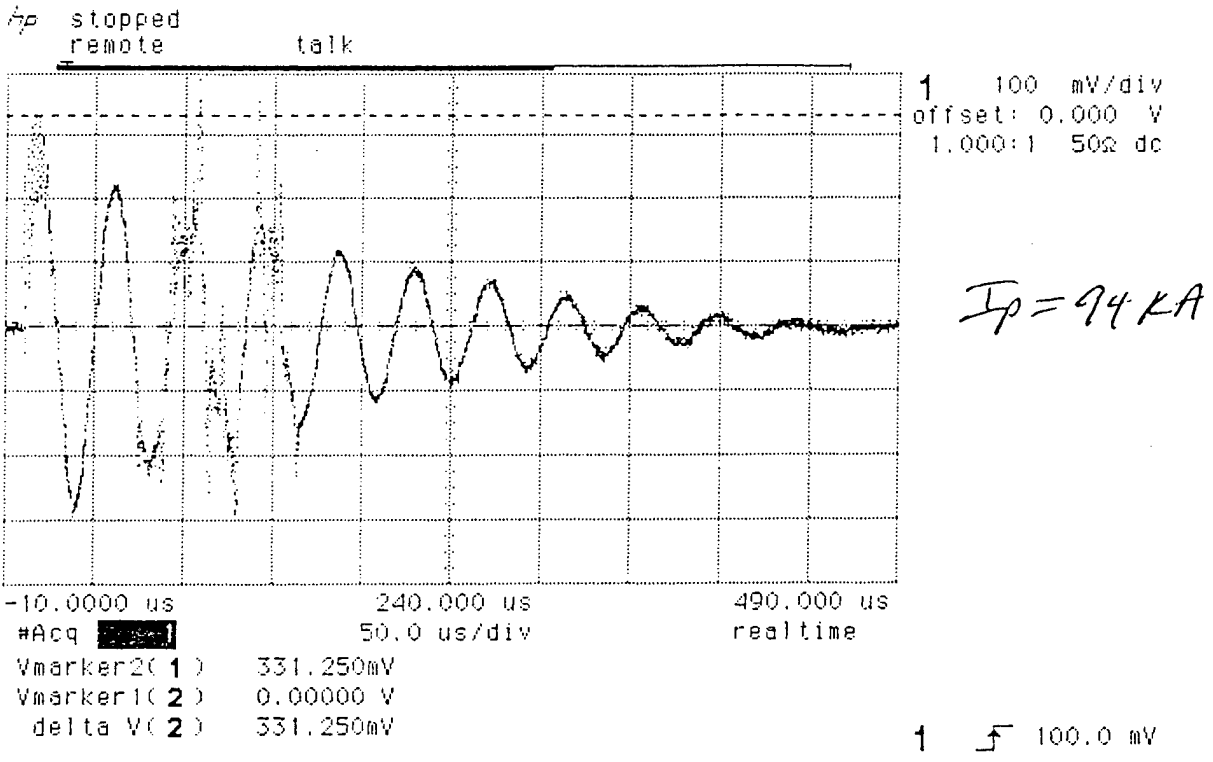

| Channel 1 | Sensitivity | Offset | Probe | Coupling | Impedance |
|-----------|-------------|-----------|-------|----------|-----------|
| | 100 mV/div | 0.00000 V | 1:1 | dc | 50 ohm |

Trigger Mode: Edge
 On the Positive Edge of Channel1
 Trigger Level(s)
 Channel1 = 100.000 mV (noise reject OFF)
 HoldOff = 40.000 ns

Figure C-32. Measurement of Component D Waveform on Panel Q11#8.

Filename: SIQ11#9D.RAW
 Date: 01-20-1995
 Time: 14:32:36

Action Integral(Channel 1) = $5.390028E-06 (400A/V)^2 (708)^2 = 0.43 \times 10^6 A^2 \cdot s$

Quick-Look Plot from HP54510A
 GPIBaddress 07 Channel 1

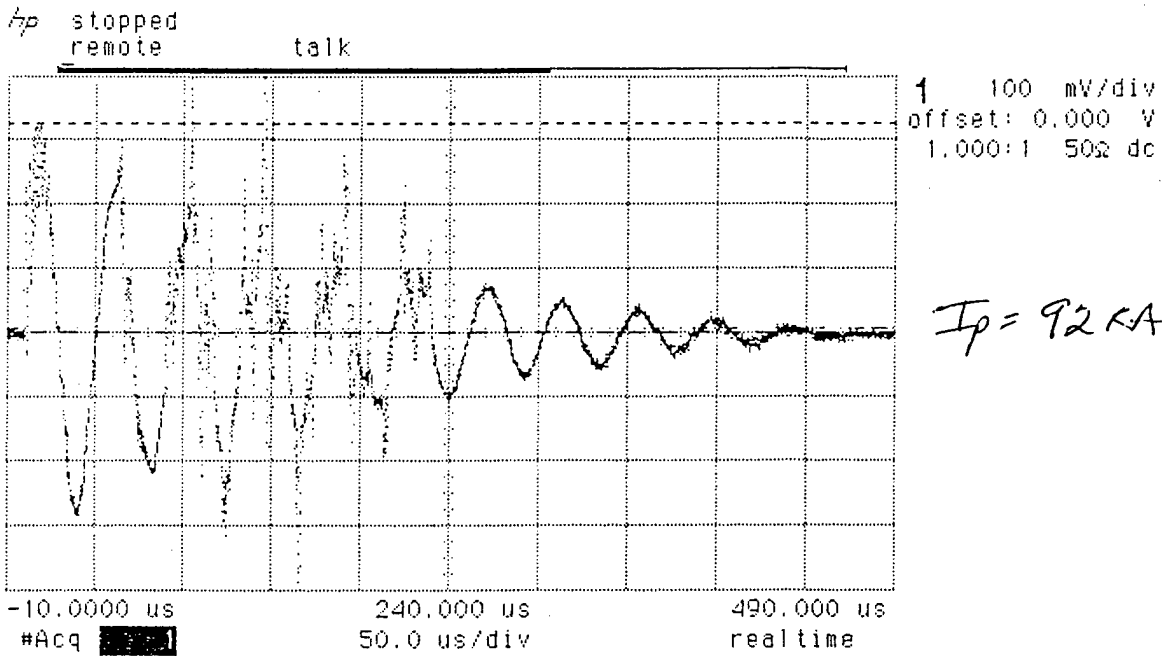

1 100.0 mV

| | Sensitivity | Offset | Probe | Coupling | Impedance |
|-----------|-------------|-----------|-------|----------|-----------|
| Channel 1 | 100 mV/div | 0.00000 V | 1:1 | dc | 50 ohm |

Trigger Mode: Edge
 On the Positive Edge of Channel1
 Trigger Level(s)
 Channel1 = 100.000 mV (noise reject OFF)
 HoldOff = 40.000 ns

Figure C-33. Measurement of Component D Waveform on Panel Q11#9.

Filename: TTC5#16A.RAW
 Date: 01-20-1995
 Time: 14:50:30

Action Integral(Channel 1) = $1.49809E-05 (500 \text{ A/V})^2 (708)^2 = 1.88 \times 10^6 \text{ A}^2 \cdot \text{Sec}$

Quick-Look Plot from HP54510A
 GPIBAddress 07 Channel 1

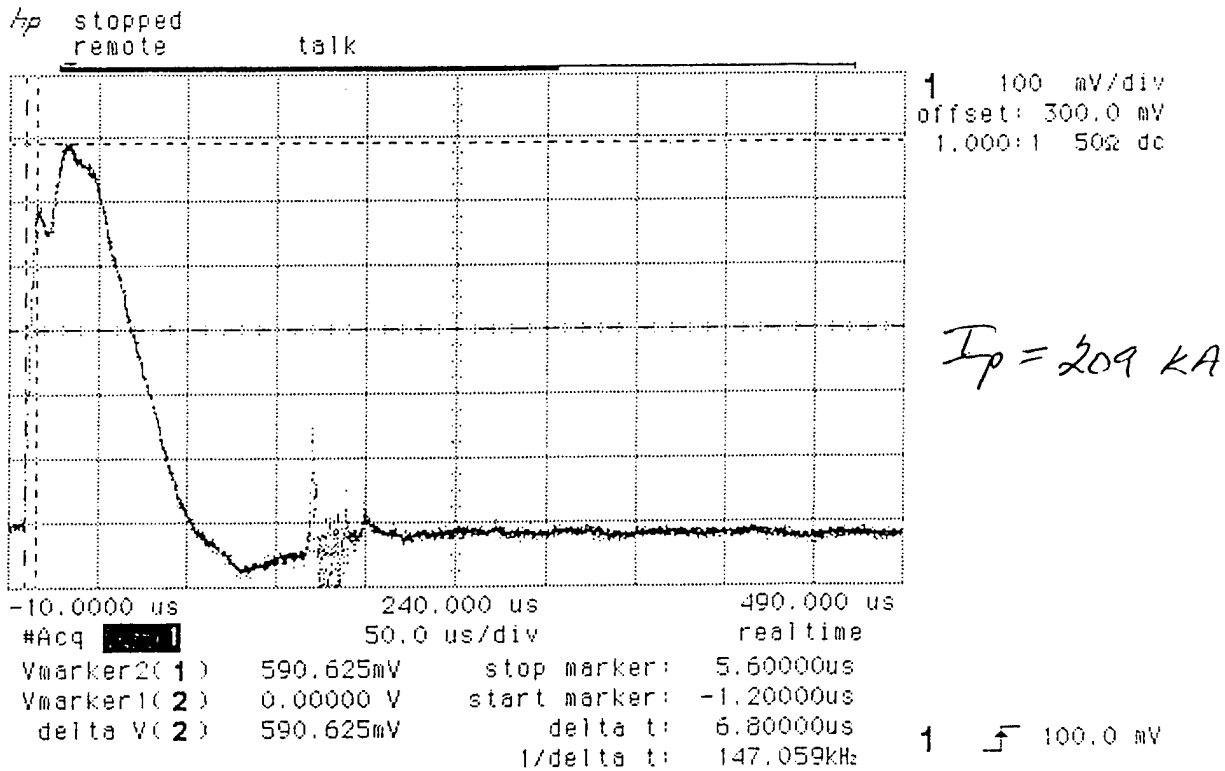

| Channel 1 | Sensitivity | Offset | Probe | Coupling | Impedance |
|-----------|-------------|------------|-------|----------|-----------|
| | 100 mV/div | 300.000 mV | 1:1 | dc | 50 ohm |

Trigger Mode: Edge
 On the Positive Edge of Channel1
 Trigger Level(s)
 Channel1 = 100.000 mV (noise reject OFF)
 HoldOff = 40.000 ns

Figure C-34. Measurement of Component A Waveform on Panel TTC5#16.

Filename: TC5#13AC.RAW
 Date: 01-20-1995
 Time: 15:20:46

Action Integral(Channel 1) = $1.497187E-05 (500A/V)^2 (708)^2 = 1.88 \times 10^6 A^2 \cdot sec$

Quick-Look Plot from HP54510A
 GPIBAddress 07 Channel 1

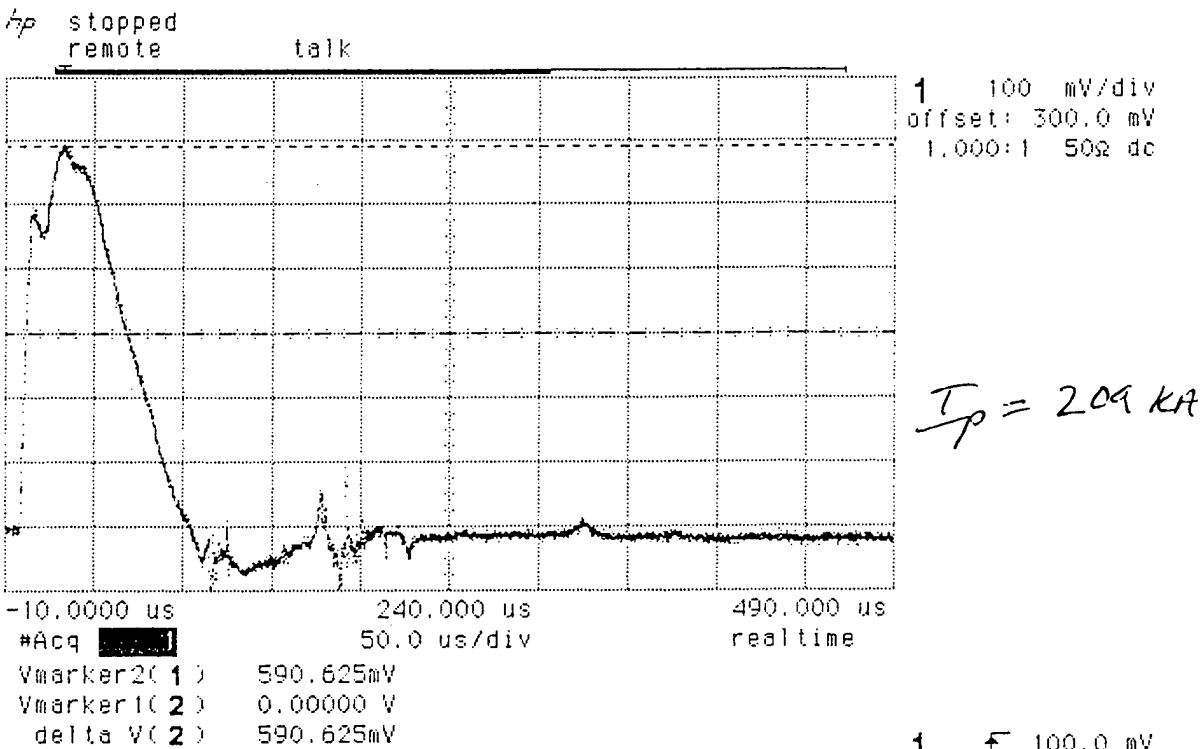

| Channel 1 | Sensitivity | Offset | Probe | Coupling | Impedance |
|-----------|-------------|------------|-------|----------|-----------|
| Channel 1 | 100 mV/div | 300.000 mV | 1:1 | dc | 50 ohm |

Trigger Mode: Edge
 On the Positive Edge of Channel1
 Trigger Level(s)
 Channel1 = 100.000 mV (noise reject OFF)
 HoldOff = 40.000 ns

Figure C-35. Measurement of Component A Waveform on Panel TTC#13.

Filename: T05#13AC.RAW
Date: 01-20-1995
Time: 15:21:49

Action Integral(Channel 1) = ~~6279000~~

Charge Integral(Channel 1) = .6361679 (20)(13.16A/V) = 167C

Quick-Look Plot from HP54200A
GPIBAddress 11 Channel 1

Channel 1 ----- Status: Acquisition Complete
LLO MTA

Range 3.0 V
Offset 1.000 V

Auto Scale Disabled
Store Mode Normal
Coupling DC 1:1

Graph 1 375 mV/div 1.00 V 200 ms/div -200.0 ms

Cursor 0

V_x -64.5 mV
T_x -140.0 ms

V₀ 1.73 V
T₀ 68.00 ms

ΔV 1.79 V
ΔT 208.0 ms

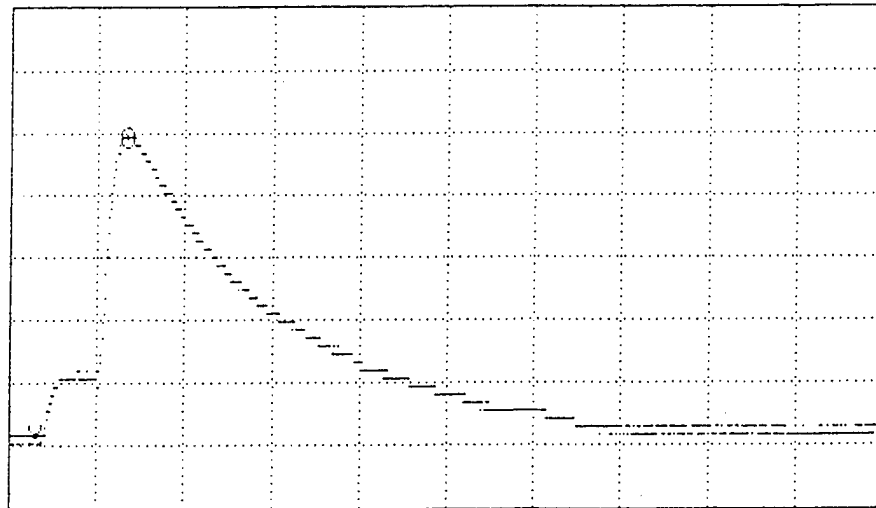

$I_p = 471 A$

Figure C-36. Measurement of Component C Waveform on Panel TTC5#13.

APPENDIX D
REFERENCES

REFERENCES

1. MIL-STD-1757A: Lightning Qualification Test Techniques for Aerospace Vehicles and Hardware, 20 July 1983.
2. "Hazardous Test Procedures For High Energy Lightning Simulator (HELs)", AMSMI-RD-S-H-6.

APPENDIX E
ABBREVIATIONS

ABBREVIATIONS

| | |
|----------------|---|
| A | Ampere |
| A ² | Ampere 2 |
| C | Coulumb |
| E ³ | Electromagnetic Environmental Effects |
| HELS | Hazardous Effects Lightning Simulator |
| kA | kilo Ampere |
| kV | kilo Volt |
| MCC-1 | Marshall Convergent Coating -1 |
| μF | MicroFarad |
| mm | Millimeter |
| μs | Microsecond |
| msec | Millisecond |
| MSFC | Marshall Space Flight Center |
| NASA | National Aeronautics and Space Administration |
| PC | Personal Computer |
| RTTC | Redstone Technical Test Center |
| TPS | Thermal Protection System |
| USBI | United Space Boosters Inc. |
| UTC | United Technologies Corporation |
| v | Volt |

DISTRIBUTION

| | Copies |
|---|--------|
| AMSMI-RD, Dr. W. McCorkle..... | 1 |
| STERT-TE/STERT-TE-P..... | 1 |
| STERT-TE-E-EM, Jeff Craven | 2 |
| STERT-TE-E..... | 1 |
| AMSMI-RD-CS-T..... | 1 |
| AMSMI-RD-CS-R..... | 3 |
| George C. Marshall Space Flight Center ATTN: SA-45, Ms. Amelia Sisk Marshall Space Flight Center, AL 35812 | 1 |
| George C. Marshall Space Flight Center ATTN: EE-13, Mr. Hank Miller Marshall Space Flight Center, AL 35812 | 1 |
| George C. Marshall Space Flight Center ATTN: GP-48, Ms. Vicky Owens Marshall Space Flight Center, AL 35812 | 1 |
| George C. Marshall Space Flight Center ATTN: BF-51, Ms. Beth Allison Marshall Space Flight Center, AL 35812 | 1 |
| Commander U.S. Army Test and Evaluation Command ATTN: AMSTE-A Aberdeen Proving Ground, MD 21005-5055 | 1 |