

020181

JPRS-UMM-86-018

13 NOVEMBER 1986

# USSR Report

MACHINE TOOLS AND METALWORKING EQUIPMENT

DISTRIBUTION STATEMENT A  
Approved for public release;  
Distribution Unlimited

19981123 016

DTIC QUALITY INSPECTED 3

**FBIS** FOREIGN BROADCAST INFORMATION SERVICE

REPRODUCED BY  
U.S. DEPARTMENT OF COMMERCE  
NATIONAL TECHNICAL  
INFORMATION SERVICE  
SPRINGFIELD, VA. 22161

5  
65  
A04

#### NOTE

JPRS publications contain information primarily from foreign newspapers, periodicals and books, but also from news agency transmissions and broadcasts. Materials from foreign-language sources are translated; those from English-language sources are transcribed or reprinted, with the original phrasing and other characteristics retained.

Headlines, editorial reports, and material enclosed in brackets [ ] are supplied by JPRS. Processing indicators such as [Text] or [Excerpt] in the first line of each item, or following the last line of a brief, indicate how the original information was processed. Where no processing indicator is given, the information was summarized or extracted.

Unfamiliar names rendered phonetically or transliterated are enclosed in parentheses. Words or names preceded by a question mark and enclosed in parentheses were not clear in the original but have been supplied as appropriate in context. Other unattributed parenthetical notes within the body of an item originate with the source. Times within items are as given by source.

The contents of this publication in no way represent the policies, views or attitudes of the U.S. Government.

#### PROCUREMENT OF PUBLICATIONS

JPRS publications may be ordered from the National Technical Information Service (NTIS), Springfield, Virginia 22161. In ordering, it is recommended that the JPRS number, title, date and author, if applicable, of publication be cited.

Current JPRS publications are announced in Government Reports Announcements issued semimonthly by the NTIS, and are listed in the Monthly Catalog of U.S. Government Publications issued by the Superintendent of Documents, U.S. Government Printing Office, Washington, D.C. 20402.

Correspondence pertaining to matters other than procurement may be addressed to Joint Publications Research Service, 1000 North Glebe Road, Arlington, Virginia 22201.

Soviet books and journal articles displaying a copyright notice are reproduced and sold by NTIS with permission of the copyright agency of the Soviet Union. Permission for further reproduction must be obtained from copyright owner.

13 NOVEMBER 1986

USSR REPORT  
MACHINE TOOLS AND METALWORKING EQUIPMENT

CONTENTS

INDUSTRY PLANNING AND ECONOMICS

Problems in Intersectorial Products Output, Repair Work Discussed (A. Kolodiyev, S. Sememtsov; PLANOVOYE KHOZYAYSTVO, No 2, Feb 86).....	1
PO Director's Management Criticisms, Suggestions (Ye. Matsegora; SOTSIALISTICHESKIY TRUD, No 3, Mar 86)...	10
Problems of Developing Machine Tool Industry in Ukraine (V. Gab; EKONOMIKA SOVETSKOY UKRAINY, No 6, Jun 86).....	20
Minister Kolpakov: Ferrous Industry Automation, CAD Goals Outlined (A. Valentinov; SOTSIALISTICHESKAYA INDUSTRIYA, 30, 31 Jul 86).....	30
Retooling Delay Causes, Effective Capital Use Examined (V. Shudra; EKONOMIKA SOVETSKOY UKRAINY, No 8, Aug 86)...	38
Party Conference Views Tasks for Advancement of Machine Building (PRAVDA, 9 Aug 86).....	43
New Bureau for Machine Building Stressing Direct Ties (A. Krushinskiy; PRAVDA, 1 Sep 86).....	45

METAL-CUTTING AND METAL-FORMING MACHINE TOOLS

Work on High-Precision Measuring Systems for Machine Tools (R. Chesna; SOVETSKAYA LITVA, No 169, 23 Jul 86).....	47
Electrophysical and Combined Machining Methods (V. S. Belov; NTR: PROBLEMY I RESHENIYA, No 13, 8-21 Jul 86).....	49
Automation at Precision-Casting Machinery Association (TRUD, No 178, 2 Aug 86).....	50
Rotary Vacuum Pump for Titanium Coating of Tools (EKONOMICHESKAYA GAZETA, No 34, Aug 86).....	51
New Toolmaking Association Includes Electronic Gauges in Sets (SOTSIALISTICHESKAYA INDUSTRIYA, No 221, 23 Sep 86).....	52

ROBOTICS

Academician Koshkin on NC Machine Tools, Industry Retooling (L. N. Koshkin Interview; SOVETSKAYA ROSSIYA, 29 May 86).	53
Development Trends in Industrial Robot Control (L. A. Sribner, Yu. V. Fridman; MEKHANIZATSIYA I AVTOMATIZATSIYA PROIZVODSTVA, No 5, May 86).....	57

/12223

INDUSTRY PLANNING AND ECONOMICS

PROBLEMS IN INTERSECTORIAL PRODUCTS OUTPUT, REPAIR WORK DISCUSSED

Moscow PLANOVOYE KHOZYAYSTVO in Russian No 2, Feb 86 pp 38-45

[Article by RSFSR Gosplan department chief A. Kolodiyev and Candidate of Economic Sciences S. Sememtsov: "Intersectorial Production: How Can it Be Further Developed?"]

[Text] In recent years, the problem of producing products for intersectorial use has constantly been at the center of attention of scientists, planning workers and economic managers. A large body of works devoted to this problem has been published. (Footnote 1) (See, for example: Yu. Muntyan. Specialization--A Most Important Factor in the Intensification of Production. PLANOVOYE KHOZYAYSTVO, 1981, No 8. G. Dzhavadov, I. Semikras. The Development of Intersectorial Production--A Factor of Machine-Building Intensification. PLANOVOYE KHOZYAYSTVO, 1983, No 1.) A series of important decisions was made at various levels directed toward accelerating the development and improving the organization and planning of the output of products for intersectorial application. Notwithstanding the measures taken and its economic import, however, the problem remains as acute as before.

The transfer of the socialist economy onto an intensive path assumes, first and foremost, the development of intrasectorial, sectorial and intersectorial specialization and cooperation. The growth of the social productivity of labor as a result of the increasing level of specialization requires 1.5-2 times less funding than in the use of other factors.

Our machine-building industry historically has and will continue to develop chiefly in the form of integrated enterprises with a closed production cycle. Most machine-building plants for the output of finished products produce, as a rule, with larger labor expenditures and funds for blanks, assemblies, parts, tooling etc. than specialized enterprises instead of obtaining all of this through cooperation with the latter. They also carry out the capital repair of equipment. Wherein many shops and sections, operating in the complement of integrated plants, are designed only for the satisfaction of internal needs and are not optimal in production volumes and the level of equipment and technology. Labor productivity in them is somewhat worse, and costs are 2-3 times greater, than specialized enterprises or optimal capacity.

Such a structure of production contradicts the requirements of scientific and technical progress and the insurance of great mobility in domestic machine

building, as well as the universal incorporation of resource-conserving technologies into production and the utmost reduction of manual labor. It was noted, at a CPSU Central Committee conference on questions of accelerating scientific and technical progress, that a considerable portion of productive capital today is obsolete, as a consequence of which the area of capital repair has swelled inordinately, return on investment is declining, the number of new jobs is increasing and, along with this, the mechanization of production is being poorly incorporated and the share of manual labor is decreasing too slowly.

In order to raise the technical and organizational level of machine-building production, increase its efficiency and give free rein to scientific and technical progress, it is essential to ensure the rapid development, compared to machine building overall, of the centralized manufacture of intersectorial products, aid the expansion of specialization and development of cooperative supply, and create enterprises for part and process specialization, the products of which would be intended for assembly plants.

The problem of developing production specialization is reflected in the draft of the Fundamental Areas of Economic and Social Development of the USSR for 1986-90 and for the Period to the Year 2000. It points out, in particular, the necessity of expanding product, part and process specialization and the cooperative nature of production, efficiently combining mechanical-assembly enterprises with specialized plants. Ensure the maximum standardization of assemblies and parts. Implement measures for the creation of machinery, equipment and instruments using standardized block-modular and base structural elements. Increase the output of multi-functional types of equipment. This, it seems to us, determines the most important direction in the development of machine building and improving its structure. The problem of rationalizing cooperative contacts and the shipment of intersectorial products immediately adjoins the question of specialization. Its resolution will also permit a considerable reduction in transport expenses on the scale of the national economy.

In the last ten years, many steps have been taken in developing the production of products of industry-wide machine-building use. The placement of responsibility for the output of such products and their technical level and quality on a number of union ministries had great significance. Minstankoprom [Ministry of the Machine Tool and Tool Building Industry] was charged with the implementation of overall coordination work in conducting a unified technical policy in this sphere.

Many of the projected measures have already been completed. Thus, beginning in 1981 the machine-building ministries are allocated dedicated capital-investment limits in the plan for the construction, expansion, reconstruction and technical retooling of enterprises and shops, producing products for industrywide machine-building use. The principal tasks, however, have still not been resolved. This is greatly associated with the fact that under conditions where increasing volumes of production in machine building and the accelerated development of scientific and technical progress have considerably complicated intrasectorial contacts and have drawn back the borders of concentration and specialization within the framework of a single ministry,

the management system for the production of products for industrywide machine-building use have lost their correspondence with the level of development of productive forces.

As noted at the April (1985) Plenum of the CPSU Central Committee, "no matter what question we consider, from what aspect we approach the economy, in the final tally all is based on the necessity of serious improvement of management and the management mechanism overall." (Footnote 2) ("Materials of the CPSU Central Committee Plenum, 23 Apr 85." Moscow, POLITIZDAT, 1985, p 11.) This relates fully to the management of the production of products for intersectorial use as well. It should be noted in this that only the integrated, balanced improvement of the management system overall, touching on organizational structure as well as planning, management methods and technical equipment, can be a pledge of success.

A most important tool for integrating the activity of various sectors, enterprises and associations is the national economic plan. How is the planning of the output of products for industrywide machine-building use implemented? There is currently no centralized planning for these products. Only the production of individual types is planned--machine-building blanks, hydropneumatic equipment, lubricating equipment and filtering apparatus, normalizing reduction gears and general-use variants, high-precision and high-strength fastener articles, and mold and core material.

The output of the given products is planned in a centralized fashion at the enterprises and associations of the Minstankoprom system through the Administration for the Coordination of Production of Products for Industrywide Machine-Building Use, and the manufacture of blanks--also through all of the machine-building ministries and other departments. Although four industrial associations belong to the indicated administration (roughly 70 enterprises), all of the products they produce do not exceed 1-3 percent of the nationwide output of such articles. If it is taken into account that Minstankoprom manufactures only 21 percent of the metalworking tools and process tooling consumed in the country and carries out less than 1 percent of the required repair of metalworking machine tools, then the conclusion can be drawn that its organizing role in the centralized planning of these products and its prospective development is insufficient.

Furthermore, territorial balance sheets for the production and consumption of products for intersectorial use, as well as composite territorial plans for the supply of these products taking into account intraministerial cooperation, are not being developed in the country. The issue of the centralized allocation of capital investment for the development of capacity for the products cited among the union republics, as well as for the machine-building enterprises of the non-machine-building ministries, has not been resolved. The department for the planning of intersectorial production at USSR Gosplan that was occupied with coordination work in this sphere on a national scale has been disbanded.

As a result, the centralized specialized production of blanks totals roughly 3 percent of its total volume. There are practically no specialized plants for the manufacture of forgings and stampings, and the centralized production of

machinery assemblies and parts is inadequately developed. Almost all machine-building enterprises produce gears, up to 65 percent produce fastener articles, more than 30 percent produce standard tools, almost all produce specialized tools, and 90 percent produce process tooling for internal needs.

Every year, due only to the dispersion of blanks output, the national economy loses 1.7 billion rubles for higher machine-building product prices, and 240,000 excess jobs are created. The low level of specialization of tool and foundry production also leads to losses.

Among the consequences of this situation are incomplete and untimely accounting for requirements for products for intersectorial use, poor coordination at the enterprises of various spheres and the practical absence of standardization.

The national economy also bears losses that are no less appreciable due to the inadequate attention toward machinery and equipment repair and the absence of a unified technical policy in this sphere. Up to the present time, funds and material and technical resources are not allocated by individual line for the development of repair production and methodological statutes, forms and planning indicators have not been developed. This has led to the creation of tens of thousands of poorly efficient repair enterprises and production through funds allocated for basic production within many ministries and departments that operate the equipment.

Departmental differences and the lack of centralized management of this process in the country has led to the fact that, out of the total number of enterprises that carry out repair operations, only 20 percent are specialized, and 4 percent have optimal capacity, with technical tooling that permits the high-quality repair of machinery and equipment. Thus, the capital repair of motor vehicles is carried out at 2,000 enterprises nationwide that are affiliated with more than 40 ministries and departments. Approximately 4,000 production areas are occupied with the repair of agricultural, construction and road machinery. Proprietary repair of machinery and equipment is poorly developed. The capacity developed in the last five years for the repair, for example, of machine-tool equipment at Minstankoprom and for electric-power equipment at Minelektrotekhprom [Ministry of the Electrical Equipment Industry], satisfies the requirements of the national economy at a level that does not exceed 10 percent.

The extant tendency in the country of developing repair production facilitates the retention of individual (basically loss-producing) equipment repair. Furthermore, there is practically no process specialization in repairing (in trucking alone it is considered to be 5 percent of the total volume of repair operations) and parts specialization is poorly developed—it is no more than 10-11 percent. Progressive methods of machinery repair (aggregate-assembly, periodic replacement of repair kits) are a small proportion. All of this predetermines large expenditures for the repair of machinery and equipment. For the national economy overall, it totals about 20 percent of all of the metal produced in the country each year. More than 2.4 million units of metal-cutting equipment are used, wherein the shift coefficient of their operation does not exceed 0.3-0.5. The efficiency of labor, material and

financial resources diverted for repair work is low. The cost of repairing machinery and equipment reaches 80 percent of the cost of new equipment, the service life between repairs is 30-50 percent, and expenses for post-repair upkeep are 6-8 times greater than its residual value.

Practically every ministry and department that operates machinery and equipment for intersectorial use carries out its repair at subordinate enterprises. Frequently, the shipping of equipment distances greater than 1,000 kilometers for repairs is carried out. The amount of this irrational shipping totals billions of ton-kilometers. For example, the Moscow Territorial Transport Administration of RSFSR Minavtotrans [Ministry of Motor Transport], with high-capacity motor-vehicle repair enterprises available in Moscow (it is true, Glavmosavtotrans [Main Administration of Motor Transport of the Moscow City Ispolkom]), sends its motor vehicles, according to intrasectorial plans, for repair to Leningrad, Apsheronk and Ivanovo at the same time as motor vehicles and assemblies arrive for repair in Moscow from other oblasts.

The task of reducing and fully eliminating irrational shipments of machinery and equipment for repairs can be resolved with the centralized distribution of repair operations. For this, the planning committees of the union republics should, in conjunction with local organs, develop optimal plans for the distribution of mass-application machinery for repair and for its production on the territory of the republic regardless of the departmental subordination of the enterprises and the affiliation of the repair fund. Organizing the development of these plans and their approval at the USSR Gosplan level would permit, without additional capital investment, not only the elimination of irrational shipments, but would also have an active effect on increasing the utilization efficiency of existing specialized capacity and a systematically reducing small repair sections, shops and workshops.

The placing in effect of reserves for raising the efficiency and quality of repair work in the country is a most important task, the resolution of which will facilitate an acceleration of social and economic development.

Negative tendencies in repair work can be overcome by creating a specialized intersectorial repair sector. The conducting of a unified technical policy also opens up great possibilities in this sphere. Calculations of specialists show that the intersectorial specialization and concentration of the repair of electric-power equipment in the amount of 75-80 percent of the requirements of the national economy would permit the freeing up 90,000-100,000 employees and the closing of 15,000 small electrical-repair workshops. Analogous operations for metalworking equipment would generate a saving of 270-290 million rubles a year, and free up 40,000-46,000 machine tools and 160,000-165,000 employees.

The chief saving from the conducting of a unified technical policy in the sphere of repairs is, first and foremost, a near doubling of the lifetimes of the repaired machinery and equipment and, thanks to this, a reduction in the requirements for repair and the corresponding expenditures of labor, material and financial resources.

Undoubtedly, most promising is a reduction in the number of repairs as a result of an increase in quality and an acceleration in the rate of machinery and equipment renewal, as well as the widespread development and dissemination of proprietary repair. No less important at the modern stage, however, is the introduction of order into existing repair work and the most efficient utilization of existing capacity, including that of the specialized enterprises of non-machine-building departments. It is also necessary to develop and realize unified plans for the specialization and development of repair work for the most widely used types of machinery and equipment, taking into account the creation both of proprietary enterprises and the development of existing specialized production to an optimal level. This work should be centralized on a national-economic scale.

The acceleration of social and economic development requires an increase in the growth rate of labor productivity and a considerable increase in the efficiency of machine-building production. All of this, taking into account the continuously expanding mix of machine-building products and improvement of their qualitative features, brings about the necessity of implementing measures for the broad development of specialization and cooperation in the production of blanks, assemblies and parts for industrywide machine-building use, tools and tooling, and the capital repair of equipment. The concentration and specialization of production of articles for intersectorial use is the basis for improving the structure of machine-building production and the systematic transformation of the universal--integrated enterprises into assembly and mechanical-assembly plants that obtain blanks, parts and assemblies from parts- and process-specialized enterprises.

A specific feature of intersectorial types of production is their gravitation toward territorial forms of organization. It is therefore especially important here to achieve an optimal combination of national-economic, sectorial and territorial interests.

Several ways of resolving the problem of managing the development of intersectorial types of production have currently been noted. Thus, the Belorussian Republic Scientific Production Association for Powdered Metallurgy was formed in Belorussia in 1981. The status of a republic committee was established for the association. Its makeup included a powdered-metallurgy institute (lead enterprise), three specialized process-design bureaus with their subordinate experimental types of production (for the production of articles of metallic powders, explosion welding, and the automation and mechanization of powdered-metal production processes) and a plant for the production of articles from metal powders.

An example of a somewhat different approach to the solution of intersectorial problems is the organization of a republic technical engineering center in the RSFSR for the rehabilitation and strengthening of machinery and equipment parts with experimental production at the Institute of Strength Physics and Materials Science of the Siberian branch of the USSR Academy of Sciences. The institute was granted the status of lead republic organization for the rehabilitation and strengthening of machinery and equipment parts in the sectors of the national economy of the RSFSR. It was charged with the following functions: the coordination of scientific research, planning,

design and process developments for the rehabilitation and strengthening of machinery and equipment parts; the determination, in conjunction with the ministries and departments of the RSFSR, of the range of machinery and equipment parts subject to rehabilitation and strengthening; the development and assimilation of technological processes, equipment and automated lines for the rehabilitation and strengthening of machinery and equipment parts, as well as the technical evaluation of the efficiency of application of the indicated processes in the national economy of the RSFSR; and the review, with the inclusion of the appropriate organizations, of new prototypes of equipment and materials and technological targets for their development.

One of the new forms of improving the management of the production of products for industrywide machine-building use in the territorial aspect is the development and realization of dedicated comprehensive programs for the development of these products in the region (oblast, kray, city). Such experience exists in Moscow and Moscow, Leningrad and Sverdlovsk oblasts.

A program has currently been prepared for the specialization and development of intersectorial types of production at enterprises of Moscow and Moscow Oblast. The chief purpose of the program is the fullest satisfaction of the needs of the Moscow region for intersectorial products with minimal expenditures of material and technical resources, a reduction in the number of workers occupied with manufacturing them, and a reduction or full elimination of irrational return shipments. Also placed in it are tasks for improving the planning and management of intersectorial types of production in Moscow and the oblast and improving working conditions, especially in small foundry, forging and packing shops where there many manual operations and high gas contamination (without the specialization and technical retooling of these types of production, the given task cannot be resolved).

The program was developed for the enterprises and organizations of 82 ministries and departments and encompasses three types of intersectorial products: products for industrywide machine-building use (blanks of iron, steel or non-ferrous metal castings; hot stampings and forgings of rolled metal and ingots; welded metal structural elements and articles from metal powders); transport containers (wooden, cardboard, polymer and metal); and, capital repair of machinery and equipment (metalworking equipment, agricultural machinery and motor vehicles, food equipment and equipment for light industry, weighing equipment and cash registers). It also envisages the elimination of small unprofitable enterprises and shops, the re-specialization of enterprises and the development of their capacity through technical retooling and reconstruction. With the aim of fully satisfying the needs of the region for intersectorial products, the creation of a network of specialized base enterprises is projected which would meet the needs of the region for blanks, transport containers etc., as well as enterprises for the capital repair of machinery and equipment. In 1990, they should meet about half of the requirements for castings and the whole requirement for precision blanks and articles from metal powders, as well as cardboard and corrugated boxes. The full elimination of the delivery of round timber and saw logs is envisaged. Only container kits and specified lumber will be supplied.

The improvement of the organization of equipment capital repair will be conducted in two stages. First, in the 12th Five-Year Plan, the capacity of existing enterprises and shops will be increased through reconstruction and technical retooling. Subsequently, the construction of several repair plants and the bringing of existing productive units to optimal size is envisaged.

Much attention is devoted to technical measures in the program. Envisaged for foundry production, for example, are measures for increasing the volume of application of progressive processes by more than one and a half times, which by the year 2000 will considerably increase their proportion of total casting volume. Also projected is an expansion of the production of all types of precision blanks for continuous processes etc.

As a result of the implementation of measures contained in the program, an absolute reduction in those employed in the Moscow region should be ensured. Output calculated per individual worker should increase by one and a half times by the year 2000 compared to 1985. The cost of product output will also decline substantially.

The development and realization of similar programs would be expedient, in our opinion, in other major industrial centers and regions of the country as well.

One promising organizational form for solving problems in the output of products for industrywide machine-building use could be intersectorial territorial associations. Their creation is envisaged by the draft of the Fundamental Areas of Economic and Social Development for 1986-90 and for the Period to the Year 2000. Included in the functions of the associations should be: centralized planning in the region of the production and distribution of products for industrywide machine-building use and the repair of machinery and equipment, including the development, in conjunction with the planning committees of the union republics, of the corresponding balance sheets, as well as the preparation of proposals to USSR Gosplan and the planning committees of union republics for the establishment of rational cooperative contacts, in particular intraministerial, for the supply of intersectorial articles and for sending machinery and equipment to centralized repair; the preparation and realization of proposals for concentrating and developing the specialization of existing, as well as the creation of new, specialized intersectorial enterprises and base shops in this area in regions based on progressive low-waste processes and industrial repair methods.

Principal attention in the activity of intersectorial associations should be devoted to the development of such enterprises as those specialized by process in the manufacture of stampings, hot-die stampings, forgings, welded metal structural elements and powdered-metal and metal-ceramic articles; specialized by aggregate units in the output of hydraulic drives, hydraulic and pneumatic automated units, lubrication apparatus, filtering devices and drive couplings; specialized by parts, producing sliding bearings, bearing shells and bushings, pinions, pulleys, shafts, fasteners, springs and other standardized parts for industrywide machine-building use; enterprises for the production and processing of mold and core materials, the manufacture of foundry and press forging tooling (patterns, molding boxes, press tools, dies and standardized

parts for them), as well as specialized plants for the centralized repair of machinery, equipment and units for them.

The appropriate scientific forces must be concentrated in these associations with the aim of implementing a unified technical policy, the development of new structural elements and technological processes and the conducting of planning operations. Many machine-building ministries now have in their complement associations of the Soyuzmashgidroagregat type, to which are subordinate specialized scientific research and planning institutes. As a result, more than 200 different types of grease pumps are currently produced in the country, but the quality of the hydraulic apparatus and hydropneumatic lubricating equipment is lower than than for many machinery units.

The creation of territorial intersectorial associations can only be, however, a step on the path of improving the organizational structure of production management for intersectorial products. The solution of problems within regions cannot completely uncover and place in the service of society all of the existing reserves in this sphere. And that is not only because the volume of intersectorial product production in the republic (and the more so in the oblasts, krays and major industrial centers) is tens of times less than for the country overall, and, consequently, even a considerable improvement in the technical and economic indicators will improve the situation on the scale of the whole national economy to a small extent. The point is still that intersectorial products are varied, and on the scale of the majority of the republics (and the more so for oblasts or smaller regions) are broken down into small groups of homogeneous articles by volume, which makes more difficult the execution of measures for expanding specialization and creating specialized enterprises of optimal capacity and, this means, only insignificantly improves the structure of machine-building production overall and raises labor productivity. The activity of intersectorial territorial associations at the national-economic level should therefore be coordinated by one of the subunits of the bureau of the USSR Council of Ministers for machine building.

Organizing the production of products for industrywide machine-building use at a modern technical level will permit an expansion of the specialization of machine building overall and a considerable raising of the level of article standardization (which will ensure an additional economic saving). Moreover, the taking into account of the economic requirements for a given product in planning will make it possible to raise the series production of machine-building production, reducing in that manner the cost of machinery and equipment output.

The implementation of the proposed measures for developing intersectorial types of production, in our opinion, will facilitate the development of machine building, the acceleration of scientific and technical progress and an increase in the efficiency of social production.

COPYRIGHT: Izdatelstvo "Ekonomika." "Planovoye khozyaystvo". 1986.

12821

CSO: 1823/189

INDUSTRY PLANNING AND ECONOMICS

PO DIRECTOR'S MANAGEMENT CRITICISMS, SUGGESTIONS

Moscow SOTSIALISTICHESKIY TRUD in Russian No 3, Mar 86 pp 38-45

[Article by Novokramatorsk Machine-Building Plant PO [Production Association] General Director Ye. Matsegora under the rubric "The Director's Turn": "A Reshaping of the Production Planning and Management Systems is Underway"]

[Text] I think that all the managers of enterprises and associations in the country approve of the introduction of the new rubric "The Director's Turn" to the pages of the journal SOTSIALISTICHESKIY TRUD. This gives them the opportunity to exchange work experience constantly on solving the great tasks posed by the 27th CPSU Congress. They are clearly formulated in the draft of the Fundamental Areas of Economic and Social Development of the USSR for the 12th Five-Year Plan and for the Period to the Year 2000 that has been brought out for nationwide discussion. It is first and foremost raising the welfare of the Soviet people based on the intensification of the economy, an acceleration of scientific and technical progress, a sharp growth in labor productivity and the rational utilization of material and labor resources.

The Novokramatorsk Machine-Building Plant Production Association has been operating under experimental economic conditions since 1984. Today, reviewing the results of the past activity of the collective, it is possible to draw several conclusions and bring forward proposals for the further improvement of the management mechanism. The activity was conducted in the following areas:

- the composition of production plans that are balanced in volume, product mix and material resources;
- the improvement of the blanks-production planning system within the plant, aimed at providing component semifinished products;
- the creation of an automated integrated system for production planning and management using computers;
- the incorporation of economic accountability in the shops that is linked to new valuation indicators;
- the development of bonus regulations that direct the work of all subdivisions toward the achievement of high end results;
- the improvement of socialist competition taking into account the new requirements;
- the incorporation of standards for the enterprise that regulate the interrelationships among the structural subdivisions of the association and

increase the responsibility of managers for the results of operations;  
--the organization of personnel training at all levels of economic education;  
--the implementation of measures directed toward raising the technical level of machinery and equipment output, reducing their labor intensiveness, improving manufacturing processes etc.

Over the last two years, a higher rate of production volume was achieved, the fulfillment of supply according to agreements was improved, the output of equipment of the highest quality category was sharply increased, labor productivity was raised considerably and product cost declined.

At the same time, we feel that a number of problems must be solved by higher-up organs for the further improvement of the management mechanism. It does not help us, for example, that the production plans are approved on the eve of the plan year. The association manufactures rolling mills, powerful press-forging machinery, excavators, crushing and grinding equipment and other equipment, of which the weight of each is hundreds or thousands of tons. The majority of the articles require individual execution, their cost is hundreds of thousands or millions of rubles, and the production cycle extends from a year to two and more years. Their launch into production presupposes a great deal of work by the design, process-engineering and economic services and the scientific research institutes of various sectors of the country's national economy. Many related-industry enterprises participate in the manufacture of the products. For the timely and high-quality preparation for production, therefore, we must receive approved yearly plans no later than 12 months before the start of the plan year, and two-three years before the start of the plan period for articles with a production cycle of greater than a year.

A second problem is the necessity of developing and approving a supply plan that can coordinate product manufacture with its shipment. No such plan exists today, and this is leading to various interpretations of supply agreements and, in a number of cases, to an incorrect evaluation of the work of the collective according to this indicator. The special conditions of the supply of heavy machine-building products require elaboration as well. For example, a question such as the minimum standard for its shipment. The absence of a precise formulation of what the minimum shipment standard is--one railcar or a multiple quantity of cars--leads to the fact that the organs of USSR Gosplan issue authorizations for the supply of spare parts in small lots. This causes considerable expense in product shipping and, as a consequence, the non-fulfillment of contract conditions.

It is also necessary to elaborate the regulations for the supply of products for export, in which the interests of the manufacturers are not taken into account. For example, the foreign-trade association, for whatever reason, cancels orders after the enterprise has already expended a great deal of labor, materials and funds on the manufacture of the products ordered and has therefore incurred large losses. This situation sharply reduces the vested interest in the supply of products for export. It seems that in these situations the foreign-trade associations should pay all of the expenditures and accept the finished product at their own warehouses and sell it on their own to other customers.

The main thing in economic activity is balanced plans for material and labor resources that are based on calculations and issued in timely fashion. That is essential for full preparation of production. All the indicators of association operations and the end results of economic activity will depend on this to a great extent.

The systems of indicators in the new conditions basically corresponds to its purpose: raise the efficiency of production. As practice demonstrates, the planning of enterprise targets for product sales volume based on the conditions for supply, product range (mix), quality and time in accordance with agreements (orders) concluded, taking into account the level of expenditures and the growth in labor productivity, facilitates to the greatest extent the fulfillment of the production plan with minimal expenditures of material and labor resources. The product-cost indicator characterizes the level of expenditures and, consequently, permits the computation of profits and the profitability of production and at the same time is the basis for price formation and is a constituent part of the calculation of the economic efficiency of new equipment, technology and design developments.

At the same time, it should be noted that indicators are planned for the enterprises that are not envisaged by the experiment (residual percentage of standards fulfillment, percentage of technically based standards, quantity of integrated and profit-and-loss teams, combination of professions etc.). A whole river of additional information is required of us for the Ministry, Gosbank [State Bank] and Gorfinotdel [City Finance Department] that is not envisaged by official reporting, but is adopted and enacted by various statutes and instructions. This diverts the management apparatus and the economic services, to a considerable extent, from their basic functions for the composition of various inquiries, and all of this is done under the guise of operating under experimental conditions. It also reduces the independence and initiative of enterprises.

We feel that in order to strengthen the vested interest of the laborers in accelerating the growth rate of labor productivity, it would be most expedient not to establish a residual percentage for enterprises for the reworking of standards for piece-workers. With the assigned 5.1-percent increase in labor productivity, the association should provide for a reduction in the level of standards fulfillment of 6 points, preserving therein the level of wages for piece-workers and even raising it somewhat.

No one objects to the fact that the setting of labor standards should be improved for the purpose of raising the share of technically based standards. In our opinion, it is essential first of all to remove the poorly grounded monitoring of the growth of hourly output, which is, after all, the growth of labor productivity in the end result: the higher the hourly output of each worker or team, the higher their productivity, the more products that can be manufactured. But over this hangs, like the sword of Damocles, the residual percentage of standards fulfillment.

We must review in timely fashion the system for evaluating the labor of piece-workers based on those indicators that do not restrain the growth of labor productivity. With this aim, we propose a transition to the establishment not

of output standards for piece-workers, but a "standard-plan." This indicator should be calculated based on the overfulfillment of the standards achieved by the workers and take into account both the assigned growth in labor productivity and the review of obsolete and reduced standards (if they exist). With such an approach, the intensity of the "standard-plan" will be assured.

The decree of the CPSU Central Committee and the USSR Council of Ministers "The Broad Dissemination of New Management Methods and Strengthening Their Influence on Accelerating Scientific and Technical Progress" raises the vested material interest of enterprises in the creation of highly productive equipment and eliminates shortcomings in the initial stage of the economic experiment. The significance of objective evaluations of product quality in the management of scientific and technical progress is increasing. They are certified according to only two categories--highest and first--which raises the requirements on manufacturers. The correspondence of product output to the best world achievements is most substantial in evaluating the technical level of production. Effective economic controls and incentives are envisaged based on certification that would stimulate the production of such articles. The surcharge to wholesale prices on the scale of 30 percent for products of the highest quality category will be established on a more well-founded basis. This surcharge is also preserved in repeat recertification.

At the same time, economic sanctions are applied to enterprises in cases where they produce first-quality products for a long period and do not reach the highest levels of scientific and technical progress.

It should be acknowledged that our association also manufactures products of first-category quality. These are crushing and grinding equipment (mills) and some types of consumer goods. Some 9.8 million rubles of these products were produced over the 7 months of this year. With a discount of 5 percent from wholesale prices, the association loses income in the sum of 490,000 rubles and the material incentive fund is reduced by 343,000 rubles. Substantial losses! We have currently taken steps to bring the quality of these products to the level of modern requirements, and first-quality products will not be manufactured beginning in 1986.

This will be facilitated by the expansion of enterprise capabilities for raising the technical level of production. Our development fund has increased by 13-14 million rubles. It should be taken into account, however, that through it we renew the existing inventory of equipment by only 2 percent a year in the face of a ministry plan of 6 percent. In order to fulfill this plan, the association must increase the FRP [industrial development fund] by two or three times. But even if we are able to do that, it will still not be possible to implement the plans for technical retooling and realize this capital investment due to difficulties in contract disposition of specialized construction organizations.

We understand that the execution of technical reconstruction in existing shops without stopping production is a quite complex and unprofitable matter for construction workers. Their vested material interest in this must be strengthened. It would also be expedient to allocate materials not as it is done now, according to the standard per 1,000 rubles of construction and

installation work, but according to the volumes of them included in the plan.

Inventors and innovators play a most important role in accelerating scientific and technical progress. In the past five-year plan, our association obtained 548 patents for inventions. Some 126 of these were incorporated into production, with an economic saving of 15.3 million rubles. The maximum utilization of inventions is restrained by existing procedure for determining economic savings from their incorporation. The changes in the "Statute on Discoveries, Inventions and Innovative Proposals" approved in 1973 should be introduced. The issue is the fact that the date of the start of the use of the invention, which is the basis of the piece of equipment or its principal element (for example, a rolling mill, large presses and other equipment with a long production and installation cycle), be determined from the operational start-up date of the piece instead of the date of its manufacture. In our opinion, this will strengthen the vested interest of inventors and innovators and increase their role in accelerating scientific and technical progress.

Guided by the party's policy of economy and thrift, the association is consistently conducting work on incorporating resource-conserving equipment and technology and providing incentives to the workers for the rational utilization of material, fuel and power resources. In 1984, the collective of the association adopted a counter plan for reducing product cost and the growth of labor productivity beyond the plan and successfully fulfilled it. The reduction in product cost beyond the plan totaled 0.7 percent, and the growth in labor productivity beyond that planned totaled 1.7 percent. But when the matter touched on additional allotments of incentive funds, it turned out that based on the incentive conditions of the counter plans, the association could not make these deductions due to the absence of profits beyond the plan (without taking into account the surcharges for efficiency and product quality), the availability of which was obligatory according to the instructions. Thus, our work on economy and thrift in 1984 through the fulfillment and overfulfillment of the counter plan was not provided with material incentives.

The association has funds that could be directed toward additional incentives for workers for the conservation of resources, but we do not have the right to use them. The issue is the funds in the material-incentives fund, expended in accordance with instructions on the obligatory procedure for the payment of paid leave. More than 0.5 rubles are allocated yearly for this purpose. These funds have no immediate incentive effect on the workers, and thus it would be better to use them for bonuses for the conservation of resources, and pay the paid leave completely through the wage fund. Economies in the wage fund could also be used as an additional source of incentive funds, although this is possible in practice only when profits beyond the plan are available.

In order to strengthen the vested interest of enterprise labor collectives in the rational utilization of resources, it would be expedient that all economies beyond the plan, or a considerable portion of them, go for worker incentives and those who provide them. Also required is an expansion of the list of resources established for the association for the economy of which the workers receive incentives, including on it non-ferrous metals, timber, raw materials mixtures, paints and varnishes and a number of others.

It can be stated with confidence that there exist all of the preconditions and conditions at enterprises for the just distribution of wages among the workers according to their real contribution to the resolution of production tasks.

In our opinion, the most reliable means of evaluating labor contributions and eliminating cases of leveling in labor wages is the incorporation and development of collective standards for their organization. The observance of the socialist principle of payments according to labor is the obligation of many responsible officials. No matter how they try to ensure the control of labor wages in strict conformity with its quantity and quality, however, it is impossible in practice for them to do this. Even a foreman who has a few subordinate workers, in the course of his duty of resolving organizational and other issues, is not able to catch all of the variety of nuances of the attitude toward the work on the part of the workers. Unfortunately, in places where the evaluation of labor contribution is farmed out to a single person, instances of prejudiced attitudes are not eliminated. After all, any person, regardless of the position he occupies, is always subject to the effect of sympathy and antipathy and, as a result--a subjective approach to the evaluation of the activity of employees.

Under the conditions of the collective form of labor organization and payment, when the labor collective itself, its own members working in view of each other, determine the wages, a subjective approach is practically eliminated. Moreover, the Law on Labor Collectives reinforced the legal basis for the resolution of this important task.

Negative phenomena cause the currently extant departmental approach to wages. The issue is those cases where the workers in one and the same profession (specialty), carrying out identical operations equal in quantity and quality but employed at different enterprises, receive differing wages. This concerns, in the first place, machine-tool operators, whose shortage is felt universally. In order to attract machine-tool operators to work, many enterprises seek all possible funds for increasing their wages. In point of fact, an unhealthy "competition" arises among enterprises for the purpose of enticing workers. Such a departmental approach, in our opinion, not only contradicts the principle of wage payments according to labor, but also creates favorable grounds for strengthening labor turnover in the national economy. With all of its complexities and facets, this problem must be resolved without delay.

The successful operation of the collective of our association is explained greatly by the broad participation of the workers, engineering and technical personnel and office workers in the management of production. Their activity has especially increased with the adoption of the USSR Law on Labor Collectives. In accordance with it, the collectives of shops, departments, sections, shifts and teams review at their meetings (conferences) all issues related to their competence and adopt solutions within the limits of their rights in accordance with prevailing legislation. The discussion of the plan draft for the economic and social development of the association for the 12th Five-Year Plan and for 1986 took place in a very active manner.

After the adoption of the Law on Labor Collectives, many creative initiatives and patriotic endeavors were formed in the association that have great significance for the national economy. Among them is the initiative of the leading engineers on the development of socialist competition for the reduction of the labor intensiveness of product output by 1,000 standard hours a year per engineering and technical worker. The economy of 2,000 standard hours is equivalent to the freeing up of one worker. Today more than 4,000 engineers and specialists are participating in this movement.

The Law on Labor Collectives considerably expanded their rights in the development, adoption and realization of collective agreements. Currently the meeting or conference adopting a solution evaluates not only the plan for the new collective agreement, but the work of the administration and the trade-union committee on fulfilling the previous ones, and issues recommendations and requests. In the course of the agreement campaign last year, more than 200 proposals were received from the laborers. The most major and important of these were included in the plan for economic and social development.

The standing production conferences (PDPS) are acquiring ever greater reputations. Some 2,439 people, including 1,484 workers, belong to them here. More than a thousand proposals are received from them each year, the realization of which over the last three years exceeded 1 million rubles. A session of shop and association PDPSs took place with the agenda "Tasks of Labor Collectives in Ensuring the Growth Rate of Production Volume in the 12th Five-Year Plan." As a result of broad discussion of the control figures, the collective of the association adopted increased socialist obligations for the five-year plan that were approved by the party gorkom and obkom.

Based on the realization of a comprehensive program for intensifying production and raising its technical level, an increase in product commodity output of 34 percent is envisaged, exceeding the control figures by 8 million rubles, including the manufacture of two ESh-6.5/45 excavators beyond the plan in 1986. The output of consumer goods will more than double, and the entire increase in production volume will be provided for--without increasing the number of workers--through labor productivity growth. No less than 70 percent of machinery and equipment output will be renewed and modernized, which will provide an economy of about 300 million rubles to the national economy. The Novokramatorsk workers will manufacture a unique hydraulic press with 45,000 tons of force for the first time in world and domestic practice. This will permit the solution of the problem of the production of thick-walled large-diameter pipe blanks for fundamentally new technology. In striving to incorporate the worthy contribution to the realization of the comprehensive program of reconstruction and technical retooling of ferrous metallurgy, we decided to modernize 80 percent of the sheet rolling mills and all of the pipe-making mills previously manufactured by the association.

In the 12th Five-Year Plan, the association envisages an increase of 46 million rubles in profits, which will permit the complete coverage of expenditures for technical retooling and the reconstruction of existing production using internal funds. Through internal sources, we intend to increase the wage scale for workers and the salaries of engineering and technical personnel and office workers. Preliminary calculations have shown

that it is difficult to find the necessary funds for these purposes. It seems expedient to accumulate them in a special association fund. It is important that these funds be rolled over to succeeding years.

I would like to dwell in more detail on the problem of limiting the number of workers in the administrative apparatus. It seems that many managers of enterprises and associations agree that there is much that is conditional in the division of employees into administrative and non-administrative personnel. The existing instructional materials include secretaries, typists, watchmen, archivists, cleaners, orderers, accountants, cashiers, timekeepers and workers of other professions among administrative personnel. This point of view can hardly be considered correct. In point of fact, an equal sign is placed between the manager of a department (or shop) and a clerk-typist, between an engineering economist and a cleaning person, between a specialist in the organization of production and a watchman located in production, between the director of an enterprise and the driver of a service car.

What administrative activity is, for example, the security worker or the cashier at the enterprise employed in? Many engineering and technical workers and office personnel, numbered among the administrative apparatus, say, workers in material and technical supply, are occupied with the immediate support of production. This work is a link in overall production labor, and it cannot be identified with administrative work. Ascribing these workers to the category of administrative personnel and reducing them annually, besides the damage, does not help matters.

It should also be kept in mind that it is possible to reduce administrative duties, but it is impossible to reduce the management functions that exist objectively at any enterprise regardless of departmental subordination: planning, accounting, setting standards, control etc. As a result of the reduction of duties and their artificial limitation by quantity and wage funds, the functions of the employees freed up are passed to other personnel. Thus, a reduction of accountants and orderers led to the fact that the fulfillment of their duties was charged to the foremen. Due to a lack of typists, typing operations are carried out by the specialists themselves to the detriment of their principal activity in the planning of highly efficient equipment and technology and the improvement of the organization of production. A lack of archivists, especially in the production of a wide range of products, leads to large time expenditures in searching out essential process documentation. A lack of timekeepers makes it much harder to monitor the established working conditions and daily routine, and so on and so forth.

Under conditions of limited administrative personnel, the association is deprived in practice of the opportunity of improving the management structure. An annual reduction in the number of administrative personnel creates an outward impression that labor in this category of specialists is less valuable than the labor of workers, engineers, designers and process engineers. In this case, who should improve the management of production, which everyone deems to be the most important factor in raising efficiency, and who should be employed with seeking out labor economies?

I would like to say several words on the existing practice of determining the number of workers in the management apparatus and establishing targets for their reduction for enterprises. The principal criterion here is the proportion of the number of employees of the management apparatus in the total number of workers or in the number of industrial-production personnel. This approach, in our opinion, distorts the true state of affairs. The point is that even when the absolute number of administrative personnel is not growing, while the total number of personnel is declining, the proportion of the management apparatus will increase all the same with the development of production automation and mechanization. As a result the enterprise that is seeking the opportunity of fulfilling the plan with the least number, with targets established for the reduction of management workers, will be in a less advantageous position than those where the total number of employees remains unchanged or even grows.

It therefore seems expedient to evaluate the level of administrative activity not by the proportion of administrative personnel, but by the results of enterprise operations. If it is successfully handling its targets, then naturally the organizational management structure is also worthy of approval.

Under existing conditions, the association is not only deprived of operational and economic independence in changing the management structure, but cannot even provide the essential administrative personnel for newly started facilities. For a long time already, for example, notwithstanding repeated requests, we have not been allocated funds for the upkeep of managers' children's pre-school institutions built by the association. It could be asked, what personnel excesses are we talking about here?

Many state funds and much labor is expended by the employees of all possible monitoring levels of authority today to seek out so-called "hidden" employees of the management apparatus. And what happens? The economic manager, who has a collective of many thousands subordinate to him and answers for the utilization of funds totaling millions of rubles, is trusted with the big stuff and... he is monitored on the petty details.

Many hopes for eliminating excessive regulation in issues of the number of employees of the management apparatus and the introduction of order in its reduction are placed on the broad-scale economic experiment on expanding the rights and increasing the responsibilities of enterprises. According to its conditions, the indicator for the number of workers is excluded from the planned number and determined independently by the enterprises. This requirement, however, is not maintained with regard to the category of administrative personnel, the number and wage fund of which are limited as before. The granting to enterprises of the right to determine independently the required number and the expenditures for the maintenance of management-apparatus employees will, in our opinion, fully correspond to the party policy for the expansion of their rights and independence and responsibility for end results.

And last. In accordance with the CPSU Central Committee, USSR Council of Ministers and VTsSPS [All-Union Central Trade-Union Council] decree "Improving

Wages for Scientific Workers, Designers and Industrial Process Engineers," the association is conducting preparatory work on the conversion to new wage conditions for this category of employee. An incentive system and conditions of competition are being reviewed for the purpose of establishing a closer dependence of the size of bonuses on the magnitude of economic saving in the national economy taking into account the importance of the development and the time for its incorporation and assimilation into production.

With the aim of finding funds for introducing the new wage conditions, the management structure is being improved, small subdivisions are being strengthened through their merging and progressive standards for labor expenditures are being introduced. In the design and process-engineering organizations of the association, the team form of organization and labor stimulation is being incorporated. A certification commission has been created for evaluating the efficiency and quality of the labor of specialists and determining their personal contribution to the development of science and technology. Especial attention is devoted to the development of objective criteria for determining the personal labor contribution of each specialist for establishing supplements to their salaries. A standing commission has been organized in the association to coordinate this work and monitor the implementation of the measures that are developed.

Having consolidated the successes already achieved, the collective of the association is applying all of its efforts so as to increase the rate of production and raise its efficiency from the first days of the new year.

COPYRIGHT: Izdatelstvo "Transport", "Sotsialisticheskiy trud", 1986.

12821

CSO: 1823/180

INDUSTRY PLANNING AND ECONOMICS

PROBLEMS OF DEVELOPING MACHINE TOOL INDUSTRY IN UKRAINE

Kiev EKONOMIKA SOVETSKOY UKRAINY in Russian No 6, Jun 86 pp 49-54

[Article by UkSSR Gosplan ENII [Experimental Scientific Research Institute] department manager and Candidate of Economic Sciences V. Gab: "Problems in the Accelerated Development of Machine Building"]

[Text] The Fundamental Areas of Economic and Social Development of the USSR for 1986-90 and for the Period to the Year 2000 indicate: "Accelerate considerably the development of machine building. Implement a radical increase in the technical level of product output. Provide for the creation and assimilation of the production of new-generation equipment that permits an increase of many times in labor productivity and a substantial reduction in material expenditures. Strengthen the material, scientific and technical bases of machine-building production." The achievement of the indicated goals should be implemented with a concurrent increase in the output of machine-building products, which amount should be increased by 40-45 percent in the current five-year plan.

An analysis of the development and functioning of the machine building industry of the Ukrainian SSR over the last fifteen years shows that in order to resolve the tasks posed, it is essential to overcome some negative trends that have taken shape that reduce the efficiency of the operations of machine-building production, which in its turn requires the solution of a number of organizational and economic problems. The machine-building industry of the Ukrainian SSR is being developed continuously at a rapid rate, which has made it possible to increase product output by 3.5 times over the last three five-year plans, while 85 percent of its increase in 1985 was obtained through growth in labor productivity. Industrial fixed productive capital increased by 3.6 times over this period, and the capital-labor ratio increased by 2.6 times. As a result, the proportion of machine-building products in the volume of industrial production of the republic over these years increased by 12.8 percentage points and reached more than 29 percent in 1985. The increase of production volume in machine building was conducted concurrently with purposeful work on the conservation of material and labor resources. Over 1971-85, the material consumption of sector commodity output was reduced by more than 11 percent, and labor productivity increased by 2.4 times. (Footnote 1) (Here and further, calculated according to initial statistical information.)

The efficiency of the development and functioning of the machine-building production of the republic is nonetheless inadequate. In the 11th Five-Year Plan, the average annual rate of increase in product volume was 6.2 percent, which is almost 5.6 percentage points lower than in the 9th; the growth rate of labor productivity lagged behind the growth rate of the capital-labor ratio--their ratio was 1.08 in the 9th Five-Year Plan, 0.94 in the 10th and 0.93 in the 11th, and return on investment over this period declined by 9.5 percent. The materials consumption of many types of machine-building products was higher than comparable world models. These trends resulted from shortcomings in planning the development of machine building and the dissipation of capital investment, which led to a systematic growth in incomplete construction (more than 90 percent in the 11th Five-Year Plan), the technical retooling of enterprises conducted without sufficient regard for the achievements of science and technology and several other factors. The technical level of machine-building production increased too slowly, which was expressed in the insignificant progressive change in the structure of the inventory of installed metalworking equipment (see table).

Structure of the Installed Inventory of Metalworking Equipment  
by Type in the Machine-Building Industry of the Ukrainian SSR, 1980-85

Type of equipment	1980	1985
Total of metalworking equipment	100	100
metal-cutting	69.7	68.7
press-forging	13.0	13.4
foundry	5.0	5.9
welding	12.3	12.0

Of all installed equipment, the number of units with numerical control in 1985 totaled 3.4 percent, or 2.5 times more than in 1980. At the same time, the amount of equipment in use beyond the standard service life increased to almost 30 percent in 1985, or 4.8 percentage points greater than in 1980. As a result, expenditures for capital repair increased by 1.48 times in the face of an increase of 1.13 times in capital investment for productive purposes. Furthermore, more than a third of all metalworking equipment is being operated in auxiliary production and there has been practically no appreciable improvement in the functional structure of the equipment over the last ten years. The proportion of metalworking equipment in basic production increased from 62.4 to 63.2 percent over this period.

A substantial increase in the technical and economic level of the machine-building production of the Ukrainian SSR presupposes the necessity of solving a set of problems in two main areas: improving the process of the

accelerated development of machine-building production and the maximum utilization of existing productive potential in the industry.

The first area includes the creation and incorporation of new equipment and an increase in its quality, as well as the determination of the optimal rate and proportions of machine-building development by improving the planning of capital investment. This requires changes in investment policy, the end result of which should be an increase in the technical level of machine-building production based on the creation of flexible production systems, standardized machine systems, robots, and mechanization and automation, which, in its turn, presupposes the formation of an optimal structure of the inventory of equipment and an increase in its technical and economic level.

The second area should be increasing the utilization factor of available productive capacity, the shift system of equipment utilization and a reduction of idle time.

Forming the optimal structure of metalworking equipment and increasing its technical and economic level is interconnected with the solving of a set of acute problems in the "science--production" cycle, since only a reduction in time for the development, manufacture and widespread incorporation of highly efficient new equipment brings about an accelerated rate of scientific and technical progress and an intensification of machine-building production.

"A fundamental task," as is emphasized in the Fundamental Areas of Economic and Social Development of the USSR for 1986-90 and for the Period to the Year 2000, "is to strengthen the connection of science and production and to create those organizational forms for the integration of science, technology and production that make it possible to ensure the precise and rapid movement of scientific ideas from their conception to widespread application in practice. The responsibility of scientific organizations for their fullest utilization must be strengthened." In this regard, the problem of improving the planning and organization of scientific research, design and planning work requires immediate attention.

An analysis of the work of scientific research, design and planning and manufacturing process organizations of the republic that are subordinate to the machine-building ministries showed that the average annual increase in expenditures for the fulfillment of plan themes over the 11th Five-Year Plan totaled 3.2 percent, while the average expenditures for one theme did not exceed 28,000-29,000 rubles each year, which testifies to the predominance of petty themes. Approximately 73 percent of the plan themes for the machine-building industry of the republic on average is associated with the creation of new equipment. The proportion of developments that is higher than the level of the best domestic and foreign models, however, does not exceed 11 percent. More than half of the organizations, moreover, have no development of that type at all, and more than 23 percent of the scientific organizations have not obtained a single patent. Of the total number of licensing agreements, 57 percent fall to two institutes--the Ukrainian Scientific Research Institute of Chemical Machine Building (Kharkov) and the Slavyansk Branch of VNIImetmash [All-Union Scientific Research, Planning and Design Institute of Metallurgical Machinery].

The work of the scientific organizations of Minstankoprom [Ministry of the Machine Tool and Tool Building Industry], Minelektrotekhprom [Ministry of the Electrical Equipment Industry] and Minpribor [Ministry of Instrument Making, Automation Equipment and Control Systems] testifies to the fact that they are not fully resolving issues of the rapid development of the enterprises of these ministries on a new technical basis and, as a consequence, of the acceleration of technical progress in machine building itself. Expenditures for the execution of developments at the scientific organizations of these ministries over the 11th Five-Year Plan totaled more than 54.5 percent of the total expenditures for all of machine building in the republic. At the same time, only 44.8 percent of the patents and 28.8 percent of the licensing agreements were obtained. Another serious shortcoming in the work of the scientific organizations of the machine building of the republic is the fact that, for more than a third of the developments conducted, their technical level was not determined.

The causes of the situation that has taken shape are: the low scientific level of technical and economic bases, planning and the organization of scientific research work, which leads to the choice of a theme that is not always topical; the poor work of the patent information services, which makes it impossible to have a progressive reference point for the formulation of the technical and economic parameters of new equipment; the existing method of evaluating the technical level of products, the use of which allows the developer-ministries to in fact dictate to the customer their own conditions for the quality of the equipment developed and produced; the poor equipping of sectorial science with highly qualified personnel (for every doctor of sciences, 2,500 workers with lower qualifications are needed, as are 50 for every candidate of sciences); the absence, in many cases, of combined developments of sectorial organizations with the institutes of the UkSSR Academy of Sciences (currently, no more than 8 percent of research is conducted jointly); and, the poor development of experimental production, which does not allow the manufacture and testing of the newly created equipment in condensed time periods. As a result, the time for conducting scientific research and experimental design work is declining too slowly, and the share of developments of completed ones is declining an average of 1-1.5 points each year.

Reshaping the work of sector scientific organizations in accordance with the tasks of intensifying machine-building production and raising the quality of the equipment developed requires the concentration of efforts on central scientific problems in every subsector. This predetermines the conducting of the appropriate organizational work in condensed time periods for determining these problems, taking them into account in the scientific research and experimental design plans and immediately providing qualified personnel and all types of resources. A large role in this should belong to interbranch scientific technical complexes, engineering centers and other new organizational forms for strengthening the connection of science and production. Positive experience in such work has been accumulated at the UkSSR Academy of Sciences and, in particular, at the Electric Welding Institute imeni Ye. O. Paton and the Institute of Superhard Materials. Efforts should be directed toward the development of systems of machinery with

the aim of creating flexible production systems, including automated ones that permit the comprehensive mechanization and automation of all stages of the process cycle, and of specific machine-building production systems--from the arrival of the raw material to the packaging and shipment of finished products; and, toward the development and broad-scale incorporation of fundamentally new, and the improvement of existing, resource-conserving technologies. The operating principle in these areas, in our opinion, consists of the study of the types and methods of operations conducted in specific machine-building production and the transfer of all of the functions for their fulfillment to progressive machinery systems developed for it.

A most important problem in accelerating the process of creating new technology and equipment is reducing the time periods for the planning of the equipment developed, which currently can be resolved by the creation and mass incorporation of automated planning systems.

The solution of the problem of improving the process of incorporating the achievements of science and technology into production and increasing the efficiency of the new equipment in operation has especial significance for the accelerated technical retooling of machine building.

In the 11th Five-Year Plan, 93-95 percent of the machine-building enterprises of the republic were incorporating scientific and technical measures (NTM). Compared to the analogous period of the 10th Five-Year Plan, 41.8 percent more additional profit was obtained, and economic saving was increased by 25.3 percent. A qualitative change in fixed capital took place through the incorporation of NTMs, more than 37 percent of which were introduced through expenditures for these measures, which was 5 percentage points higher than at the beginning of the five-year plan.

At the same time, the average annual growth rate of expenditures on NTMs totaled 2.75 percent in the 11th Five-Year Plan, which is 1.8 percentage points less than in the preceding one. Approximately 51 percent of all expenditures were spent on the automation and mechanization of production, and the time for their recoupment in these areas, although it did not exceed the standards, increased by 1.8 and 0.2 years respectively. Notwithstanding the fact that more than 94 percent of the NTMs conducted were directed toward raising the technical level of production, less than half of the increase in labor productivity over the five-year plan was obtained through this factor on average.

The results of the analysis made it possible to draw the conclusion that the scale of NTM incorporation and the quality of the equipment incorporated is still not having the proper effect on raising the efficiency of machine-building production. The low effectiveness of some NTMs is explained to a considerable extent by the practice of incorporating them has taken shape. This is, in the first place, the imperfection of the planning of production and distribution of new equipment, which does not permit the realization of achievements in this sphere in a short time due to the incompleteness of its supply for this or that production; the absence of essential equipment, and other factors. Matters with regard to NC machine tools, the efficiency of which is low at many machine-building enterprises, are especially

unsatisfactory (the recoupment time exceeds the standards by 2-3 times and more).

The insufficient output of progressive equipment restrains the incorporation of highly efficient resource-conserving technologies such as technologies for the mechanical machining of metal instead of cutting, powdered-metal technologies, welding, die-welding, laser, electron-impulse, rolling, technologies for the production and utilization of new structural materials in place of ferrous and non-ferrous metals etc. Often the effectiveness of the new equipment is reduced due to unsatisfactory operating conditions in specific production settings, and in some cases, errors in its planning. At the end of the last five-year plan, approximately 40 percent of the mechanized and automated lines in the machine building of the republic had not achieved the planned productivity. The proper monitoring of the effectiveness of the new equipment is not being implemented. A selective analysis showed that more than half of the scientific and technical measures did not have indicators of their effectiveness in the statistical reporting forms for the new equipment.

Improving the process of incorporating scientific and technical measures is possible only as a result of the coordination of the new-equipment incorporation plans with production. The share of the increase in production volumes and labor productivity and the decrease in product cost and other principal indicators through the incorporation of new equipment should be taken into account in the product output plans at the enterprise and ministry levels. There should be analogous information in report documents. Material incentives for the incorporation of new equipment should be implemented only when the intercoordinated plan indicators are fulfilled.

In order to ensure the broad-scale incorporation of the resource-conserving and unattended technologies developed, it is essential to conduct organizational work on determining the specific types of articles that can be expediently switched over to machining by progressive processes. The sectorial institutes and enterprises must envisage, in the plans for reconstruction, technical retooling and new construction, along with the incorporation of only progressive technological processes.

Improving the organizational structure of machine building has most important significance in resolving problems of accelerating the incorporation of new equipment, which should be directed toward creating scientific production associations (NPO) and ensuring qualitative changes in the structure of existing enterprises and the organization of highly specialized production based on concentrating products and progressive technologies that are similar in design and technology. The scientific design subdivisions in the complement of the NPO should become centers of scientific and technical thought, and their developments should provide for increasing the technical economic level of existing production and product output that is no less than of world caliber.

One of the key problems of machine building is closely connected with the stages of development and incorporation of new equipment--the problem of increasing the technical economic level of product output, that is, increasing its quality. The solution of this problem should begin with the development

of documents that regulate the process of raising the quality of machine-building products.

Various terms are currently employed in practice and in specialist literature for characterizing product quality (product technical level; scientific and technical level; product levels that exceed or correspond to the best domestic and foreign developments etc.) that do not always permit a specific quantitative evaluation of the quality of this or that product. In our opinion, the term "product technical economic level" includes the evaluation of two important aspects of its quality. The technical level is determined by the design solutions that characterize the correspondence to the world level of analogous products or its surpassing according to technical economic parameters (productivity, reliability, longevity, power and electrical consumption etc.). The economic level reflects expenditures for the achievement of a product technical level, that is, the cost, which is formulated by materials consumption and expenditures for the manufacture and operation of each type of product output. Thus, it is precisely in the determination of the technical economic level that the opportunity arises for reliably evaluating the efficiency of each type of product and obtaining information for controlling its quality.

The existing procedure for monitoring and evaluating product quality cannot fully satisfy the requirements for accelerating the rate of scientific and technical progress in machine building. The point is that at the development stage of new equipment, proper attention is not devoted to the formulation of progressive parameters for the product technical economic level. In the overwhelming majority, they are monitored by the producer-ministries and not by the customer. Intrasectorial monitoring does not always have an objective character and the technical economic level of the products is often exaggerated. In order to strengthen intra- and inter-departmental monitoring, it is essential to create a unified technique for evaluating the technical economic level that should encompass all stages of the "science--production" cycle and be coordinated with the state certification system for the quality of industrial products.

The resolution of the issues considered above in improving the planning and organization of operations at the creation and incorporation stages of highly efficient new equipment is an essential condition for the development of a scientifically based plan for capital investment in machine building. Its development should take into account the needs of the industrial sectors, as well as the national economy overall, for machine-building products. These two conditions predetermine an increase in the level of grounding of the capital-investment plan, which will permit the fullest accounting for the tasks before the sector, the elimination of existing disproportions in its development and the acceleration of the rate of its technical retooling.

The Fundamental Areas indicate: "Increase the efficiency of capital investment and improve its reproductive and technological structure. Concentrate material, financial and labor resources first and foremost on the technical retooling and reconstruction of existing enterprises and on the construction of facilities that determine scientific and technical progress and resolve social tasks."

The territorial and intrasectorial structure of capital investment in the machine building of the republic is formulated at the highest management levels of the country with a regard for nationwide proportions in sector development. The rapid development of sectors that ensure the acceleration of the rate of technical progress in machine building itself and the resolution of other nationwide tasks of the Food and Energy programs among others are taken into account in this.

The reproductive structure of capital investment is formulated to a considerable extent at the all-union machine-building ministries and republic planning organs. The share of capital investment for the technical retooling and reconstruction of the machine-building enterprises of the republic in the 11th Five-Year Plan, taking into account equipment that is not a part of the estimate for construction sites, increased by 52 percent (versus 41 percent in the 10th). The average annual coefficient of the introduction of industrial fixed productive capital for enterprises of the machine-building ministries located on the territory of the Ukrainian SSR, however, is more than 5.6 times greater than the average coefficient of its withdrawal, which testifies to the aging of the assets in operation and the inadequate efficiency of the reconstruction and technical retooling of the machine-building production of the republic. This is explained by the fact that in capital-construction practice the expansion of production and, in some cases, new construction is often substituted for reconstruction and retooling. Cases are also well known where the technical retooling or reconstruction is conducted on an old technical basis. In many ministries, the plans for capital investment, as a rule, are not fulfilled each year. All of this does not facilitate rapid technical retooling and an increase in the efficiency of capital investment in existing machine-building enterprises and restrains the formation of an optimal structure for their equipment inventory.

The formation of the optimal technological, age and functional structure for the equipment inventory in machine-building production, a most important factor in raising the efficiency of its operation, basically depends on the quality and depth of the engineering base right at the machine-building enterprises. The economic and technological services of the enterprises should approve the plans for reconstruction and technical retooling only taking into account the latest achievements of science and technology and the product range that will be produced at this enterprise after the completion of reconstruction and technical-retooling operations.

This problem is closely linked with raising the functional efficiency of machine-building production and improving the utilization of existing productive potential, including the available inventory of equipment, since many disproportions that exist in specific production were predetermined as early as the planning stage of its development. It is especially important to determine the proportion of the distribution of equipment being introduced for increasing the capacity of specific machine-building production and the replacement of outmoded and obsolete equipment.

Analysis shows that over the last 10 years, the utilization factor of productive capacity for the enterprises of nine machine-building ministries

declined by 2.9-8.2 percentage points, and increased only for the enterprises of Minkhimmash [Ministry of Chemical and Petroleum Machine Building] and Minstroydormash [Ministry of Construction, Road and Municipal Machine Building] by 3.8 and 1.6 percentage points respectively. Considerable reductions were observed at Minselkhovmash [Ministry of Tractor and Agricultural Machine Building]--8.3 percentage points, Mintyazhmash [Ministry of Heavy and Transport Machine Building]--6.7, Minelektrotekhprom--4.7, Minenergomash [Ministry of Power Machine Building]--6.4, and Minzhivmash [Ministry of Machine Building for Animal Husbandry and Fodder Production] and Minleppishchemash [Ministry of Machine Building for Light and Food Industry and Household Appliances]--4.3 percentage points. The volume of products per unit of equipment for machine building in the republic overall declined by 1,600 rubles compared to 1977 at an average annual rate of decline of 1.6 percent.

The principal causes are an increase in daylong equipment idle time for planned repairs and modernization (from 10.2 to 20.4 percent), defects and unplanned repairs (from 11.6 to 15.6 percent) and several other reasons, as well as the low shift coefficient of the equipment and its low growth (from 1.40 to 1.43). The increase in equipment idle time with regard to planned and unplanned repairs is associated to a considerable extent with the growth of the number operated beyond the standard lifetime with insufficient new equipment sent for its replacement.

The task of renewing more than a third of the real assets of fixed capital, increasing (at least doubling) the withdrawal of obsolete fixed productive capital compared to the 11th Five-Year Plan and bringing the shift coefficient of equipment operation in machine building to 1.6-1.8 and higher in 1990 requires particular attention to this issue.

The principal reserves for raising the shift coefficient of equipment operation lie in improving the organization both of internal plant development planning and the functioning of specific types of machine-building production, which should be directed first and foremost toward raising the shift coefficient of unique equipment and equipment operating at bottlenecks in the technological cycle. This requires executing a set of operations on creating flexible production systems and automated and mechanized process lines and their correct utilization and operation under conditions that permit the complete realization of the inherent potential efficiency.

In order to stimulate work on the second shift, it is essential to disseminate the experience of leading enterprises, and specifically the Kievorgmash PO [Kiev Trade Machine-Building Production Association], at which, within the framework of the material incentives fund, funds are allocated for material incentives for employees that are not on the basic shifts. Such types of incentives as the immediate provision of work passes for relaxation, the establishment of holiday time at their option, the preferential distribution of living space and others also have a certain significance.

Much has been done over the 11th Five-Year Plan in the machine building of the republic on economizing the principal type of raw material--ferrous metal. The average annual rate of reduction in its consumption per 1 million rubles

of commodity output reached 2.8 percent, and 3.9 percent for rolled metal. The utilization factor of rolled metal increased from 0.7 to 0.77. At the same time, in such metal-intensive types of production as machine-tool building this factor was only 0.58 in 1984 and worsened by 0.21 points over four years. The worsening was 0.04 points at the enterprises of Minkhimmash. At the enterprises of several ministries, the utilization factor of rolled metal is considerably less than average for republic machine building.

An analysis of the structure of the equipment inventory shows that the slow growth of the proportion of press and forge, foundry and welding equipment, which is used namely in blanks production, predetermines the non-optimal proportion of development between blanks and metalworking production. This disproportion is being reinforced and is caused to a considerable extent by restraining the incorporation of highly efficient materials-conserving metals mechanical machining processes in place of cutting and increasing the proportion of chips in metal byproducts. Currently, the capacity of metals machining by cutting at the machine-building enterprises is so great (the proportion of non-operating equipment of the total quantity installed in the machine building of the UkSSR totaled 11.5-13.9 percent each year of the 11th Five-Year Plan) that it is more than adequate for the machining of metal even with the notoriously large tolerances and allowances for parts. This, on one hand, does not provide an impetus for the transition to more economical technology and, on the other, leads to the fact that all the more metal goes to chips. In the 11th Five-Year Plan, the average annual increase in the amount of chips totaled 1.25, and its proportionate share of metal byproducts increased by 1 point versus 1980 and reached 50.9 percent. Many enterprises are also not fulfilling the targets for reducing the planned metals consumption norms.

In our opinion, the task of reducing the materials consumption of products must be resolved in three major spheres of scientific and production activity. First, in the sphere of scientific design activity. Here it is essential to reduce both the absolute and the proportionate consumption of all types of material resources of the machinery, equipment, part etc. being created through the realization of the achievements of science and new design ideas. Second, in the sphere of creating material resources for machine building, that is material resources created in such sectors as ferrous and non-ferrous metallurgy and the chemical industry. These sectors should considerably expand the mix of product output, increase the production of cold-rolled sheet, cast and curved shapes and economical types of alloys and considerably increase the output of metal substitutes--plastics, metallic ceramics etc. A considerable portion of complex machine-building parts, especially small ones, should be switched over to manufacture by powdered-metal methods. And third, in the sphere of the partial creation and processing of all material resources for finished products, that is in blanks and metalworking production in machine building.

COPYRIGHT: Izdatelstvo "Radyanska Ukrayina", "Ekonomika Sovetskoy Ukrainy", 1986.

12821  
CSO: 1823/309

INDUSTRY PLANNING AND ECONOMICS

MINISTER KOLPAKOV: FERROUS INDUSTRY AUTOMATION, CAD GOALS OUTLINED

Moscow SOTSIALISTICHESKAYA INDUSTRIYA in Russian 30, 31 Jul 86

[Article by SOTSIALISTICHESKAYA INDUSTRIYA special correspondent A. Valentinov under the new rubric "The Minister Responds": "Paradoxes of Communicating Vessels"]

[30 Jul 86 p 2]

[Text] The words in the headline are the name of a new rubric of SOTSIALISTICHESKAYA INDUSTRIYA that the newspaper intends to open in August. Its essence is a direct and candid dialogue between newspaper readers and the managers of the most important sectors of the national economy and of ministries and departments. This is a specific and vital form for expanding publicity, without which, as was emphasized in the Political Report of the CPSU Central Committee to the 27th Party Congress, there is not and cannot be democracy, political creativity of the masses and their participation in management. All that is done in our state and our society should be done in public, monitored by the people and in view of the people. The new rubric of SOTSIALISTICHESKAYA INDUSTRIYA serves this purpose.

The first to agree to answer readers' questions is USSR Minister of Ferrous Metallurgy Serafim Vasilyevich Kolpakov.

Metallurgy has long been called the backbone of industry. The might of the nation is evaluated by its output of metal. Much has to be done by Soviet metallurgists in the 12th Five-Year Plan. The sector must first of all be retooled with more productive equipment and the technical retooling and reconstruction of veteran plants must be accelerated. The output of finished rolled metal must be brought to 116-119 million tons in 1990 without any growth in the production of pig iron and with a substantial reduction in the consumption of coke.

Of course, metallurgists themselves pose many questions to their minister. Both on the matters in the sector and at enterprises and on the development of the social sphere of workers' towns and cities.

Ferrous metallurgy is one of those industries whose operating rhythm is felt in the whole national economy. We therefore welcome machine builders, construction workers, petroleum workers and all who are concerned with, troubled by or interested in the problems and concerns of ferrous metallurgy and its prospects to join the discussion.

Send your questions by telegram or letter with the notation "The Minister Responds" on the envelope by August 10 to the address: 125880, GSP, Moscow, A-137, Pravda St., 24, SOTSIALISTICHESKAYA INDUSTRIYA.

We await your letters and telegrams.

#### 1. Far From Ideal

I recall a discussion not so long ago with the former chief of the Glavproyekt [Main Administration for the Planning of Ferrous Metallurgy Establishments] of one of the union ministries. A most experienced specialist of the old guard of planners, he had returned from a business trip abroad not long before our meeting. Now he was sharing his impressions.

"The planners really have it nice over there!" he said, shrugging. "They sit in soft chairs and have a smoke. In front of each are two displays with buttons. Push a button and a reference, estimate or engineering calculation is on the screen. Push another and there is a drawing on the other screen. One version, two, three... If you don't like it, touch the screen with a light pen and the machine does it over on the spot, any way you like, and draws it on paper itself. It is convenient, of course, but after all man comes after the machine and becomes an adjunct to it. And where is the creativity here? Where is the enlightenment?"

A clear disapproval of such a "belittling" of the role of the planner, who no longer has to wear out his feet at the drafting table, drawing out each line, keeping a mass of standards information in his head and, because of a chronic shortage of time, not having the opportunity of making at least a pair of project variants from which to choose the better one, could be heard in the voice of my interlocutor. I tried to understand why my interlocutor did not notice the underwater portion of the iceberg behind the machine terminal--the enormous labor of a multitude of highly qualified specialists who filled the computer data bank with world experience and taught it to consider, draw and evaluate variants. And mainly, why he did not understand that the computer-aided design system (SAPR) far from removes man to the background and deprives him of the right to enlightenment. On the contrary, it requires that the planner be elevated to a qualitatively new creative level.

It is not only old specialists, however, that see just the tip of the iceberg. However paradoxical, up to now the majority of planners of all ranks and ages interpret SAPR the same way as the drafting table or the minicalculator--an apparatus that eases and speeds up planning and calculating and no more. And in all conscience, it is difficult to fault them for this: they have not had the chance for any other interpretation.

Just what is SAPR? First of all, it is a fundamentally new ideology in planning that requires a radical break in established conceptions. The main thing is that a planner creating a specific facility employs programs that were developed by other specialists. And these programs are suitable for a great multitude of similar facilities. Just enter your own data, and the machine begins to draw line after line and turn out number after number. Under these conditions, it really is possible to sit in a soft chair and have a smoke while watching the display. But these are external attributes, and the main thing is that all that is now required of the planner is to think, analyze and search for new possibilities. In short, the highest forms of creativity are entrusted to man.

Hence the technical features of SAPR: instead of drafting tables, T-squares and minicalculators, there are two displays, a numerical and a graphical one with a device for entering graphical data, and a graphics plotter that transfers the drawing "approved" by man from the screen to paper. All of this is called an ARM--an automated workstation.

This is the ideal. As it should be. And in ideal form, automated design systems have a mass of advantages. The chief one is that any plan can be rendered at a high level, insofar as there exists the possibility of choosing the best from a series of variants. This means that the time and funds expended for the formulation of programs for the computer are recouped many times over in the construction of facilities and the creation of machinery, structural elements and instruments. And it is precisely toward this, the raising of the quality of plans, among other tasks, that the June (1986) Plenum of the CPSU Central Committee directed us.

I intentionally began with what should be. Because "what should be" is strikingly different from "what is." The measuring point was established by directive documents as early as 1981--to bring the level of automation in the near future to 15-20 percent of the total volume of all planning work.

This threshold does not seem high today. And not only because it is reaching 80 percent abroad. The planning process includes the most varied of operations: from the purely creative--the creation of new designs for buildings, machinery, new processes--to the routine but essential--such as the composition of estimates and specifications. And all of this can be programmed and entrusted to computers. The established level of distinction among these operations is not being made: the effort to have always and in everything a "number for reporting" from years past has had an effect. But this was creating real preconditions for hiding the heart of the matter with a "favorable report." They collected "percentages," automating the routine and support operations. But "numbers," after all, are in effect up to now. And

the organizations that achieved this level are today considered "favorable." Among them were mentioned to me Gipromez [State All-Union Institute for the Planning of Metallurgical Plants] and GIAP [State Scientific Research and Planning Institute of the Nitrogen Industry and Products of Organic Synthesis] at USSR Gosstroy [State Committee of the Council of Ministers for Construction Affairs].

Why single out Gipromez from among the others? First of all, equipment. The institute has an imported system with twenty terminals. All of the displays are in one room where the planners go. This is inconvenient in and of itself. But the main thing is something else: before beginning work, the planner, along with the computer, has to make a program--there are no prepared ones. This means that first you develop a program yourself, and then you work with it yourself. You have to do double work. Not only is one of the chief advantages of SAPR--acceleration--lost, but the very essence of automated planning is distorted.

"If only that was all we had to worry about!" sighed A. Klekl, the department chief. "In order for our SAPR to operate effectively, we need, by the most modest estimate, 300 displays in the department. Half of them are graphics displays. So far we have one, and that one doesn't even work: there is no device for entering the graphics. In other words, we don't have a single ARM. But we can still at least do something or other on our equipment--estimates, economic specifications... Overall, we are pulling our 20 percent."

The metallurgists have long been overtaken by the chemists. GIAP, developing a program for a number of chemical sectors, is equipped with three computers and 117 displays. It would seem that that is a lot. But there is only one graphics plotter for the whole institute, and even that one can still only draw the borders of the drawings.

"We wanted 25 percent automation of planning operations," said Deputy Chief Engineer N. Konovalov. "And that was the limit. We are doing all kinds of calculations, estimates and specifications. But the way we're doing them!"

Yes, it must be thought that the ideologists of SAPR did not suspect what surprising forms the realization of their ideas would acquire. This is how the programs for estimates are composed, for example. First the estimator fills out special cards that are divided into a multitude of squares. A number must be entered in every square--and just make a mistake! Then the associate from the computer center collects the data on perforated tape and the estimator verifies it--long and tedious work.

"What is the economic saving?" I ask Konovalov.

"Who knows," he shrugs. "If there is one, it's a pittance. We thought of holding a competition between the estimator and the machine--who's faster? And if the machine wins... Well, we'll begin teaching the estimators to work directly with the computer without computer operators."

That is where it is necessary to begin. The new planning ideology requires a radical restructuring of the whole system of work. We have been trying to squeeze it into a traditional and backward one. Hence the attitude of the planners squeezed into the tight framework of old standards and rules. Many of them were unable to be restructured for the new thinking. In this most complex problem, the human factor has turned out to be one of the most difficult aspects to resolve.

[31 Jul 86 p 2]

## 2. An Incomplete Complex

"Name the main link at which the whole chain of this problem can be removed," I asked at Gosstroy, Minpribor [Ministry of Instrument Making, Automation Equipment and Control Systems], Gosplan, Gipromez, GIAP and TsNIIproyekt [Central Scientific Research and Planning Institute]--everywhere that they are working on the intensive incorporation of SAPR. And everywhere I was answered the same way: equipment! Computers, displays, graphics plotters--that is what the "SAPR men," as they call themselves, are concerned with first of all. And from the details they reported it became clear that all is not well with the equipment for automating planning here.

Behind this very softly worded formulation there stands a consistent phenomenon that was caused by an initial error--the absence of a unified coordinating center. No organization was found that would bring together the plans of the various departments, balance them against each other and determine a general policy for the development of the new sphere of application of computer equipment. A department existed at one time at the GKNT [State Committee for Science and Technology] which was entrusted with coordinating the work on SAPR. It was, however, disbanded in 1983. It was felt that the main thing had been done: a directive had been issued. Later, of course, the department was revived, although with somewhat different functions, but the pace had been lost. And there was no one to bring all of the work into a unified channel. Each sector thus took its own road. And if there was anything common in their work, it was the effort to fulfill the directive by the easiest method: create a new sector on top of an old and strongly assimilated one. Hence the difficulties today, the chief of which is that the planning automation equipment that we have is not the kind needed.

Planners abroad have already long ago made the change to special technical equipment. Domestic SAPR is still based on general-purpose computers that do not generate a complete solution to the tasks. Start with the fact that they operate in batch mode, receiving assignments from perforated tape. For SAPR this is yesterday, insofar as today the planner must conduct a direct dialogue with the machine. Furthermore, domestic computers, successfully operating in all other sectors, do not provide adequate memory capacity for SAPR and do not have graphics systems for the input and output of information, and without this, automated planning is a piano without keys. It is true that lately special ARMs have appeared here for planners, but our designers have been unable to bring them to a world level. Thus, the system developed by Minradioprom [Ministry of the Radio Industry] using a YeS-1066, four displays

and a graphics plotter takes up 200 square meters of floor space and costs 4.5 million rubles. A Western set-up of roughly the same capacity takes up 10 square meters and costs 600,000 when converted to rubles. The main thing is that while the foreign computer answers the planner's questions in at most five seconds, one must wait no less than half a minute with ours.

But there is not even enough of that equipment. Trying somehow to "saturate" their planning organizations with it, so as to report on the incorporation of SAPR, almost all ministries "chop up" the sets: one institute gets a computer, another the display, and a third is allocated foreign currency to acquire foreign equipment. As a result, the planners acquire equipment which is quite difficult, and sometimes altogether impossible, to "put together." Right from the beginning, by the way, a comprehensive system was never organized for the supply of programming. Foreign firms supply customers not simply with equipment, but with equipment and program complexes: machinery and software--a set of standard programs for problem resolution that are compulsory in this or that planning sphere. The diversity of departmental interests has compelled us to entrust software to a special organization--SoyuzEVMkomplekt. Concluding an agreement with them, customers confirm that one must wait years for programs from them and that it is more reliable to take care of yourself. Thus, the circle begins to close, the essence of which was precisely characterized by GKNT department chief V. Boyko:

"Do you know what a program costs? Even a standard one that includes the obligatory and well-known tasks--serious money. A batch of programs for the complete planning of a facility can't be handled by one organization alone. There is, however, practically no intersectorial cooperation."

Thus was formed the second component of the closed circle--the diversity of departmental interests hindered the creation of an effective tool for SAPR functioning--intersectorial programming centers that are envisaged, by the way, by directive documents. The task of these centers is the discovery of requirements for this or that program, the organization of its development and its provision to those who need it. In other words, an intermediary firm trading in programming--the most expensive and scarce product in today's world.

It is true that one such firm has appeared in the Minpribor system--the Tsentrprogrammssystem NPO [Central Programming Systems Scientific Production Association]. In theory, any organization in the country can obtain any programs here, if they have them. The latter proviso is extremely significant. In order to sell someone a program, it must be ordered by someone else. And there turned out to be no one to order. In the end, Minister M. Shkabardnya issued an order in May of last year according to which he specifically charged his institutes with developing 70 sector-wide programs to stock the fund of Tsentrprogrammssystem. They were, however, first of all planned only for ARMs produced by Minpribor and, secondly, intended only for the automation of management functions. The latter is understandable: Minpribor does not have specialists that are able to compose programs for construction or design work. But why didn't they cooperate with other sectors? It is noteworthy that I obtained no clear answer to this question at Minpribor. Everyone I turned to shrugged in embarrassment: this idea never

entered their heads. On the other hand, there were no riddles on this account at another organization occupied with SAPR--TsNIIproyekt.

"This is a universal phenomenon, and there is one cause for it: the fear that 'somebody else's uncle' won't provide for you," smiled Yu. Rozendorf, chief of the SAPR methodology department. "And every sector tries to conduct its own physical facilities. So, having collected suitable equipment bit by bit at random, many organizations begin to cling--there's no other word--to their programs. And why share them? The more so as it is practically impossible to sell them: our financing system does not envisage a planning organization selling its output. And it is even dangerous to sell them: the level of these programs is often such that a scandal could erupt..."

That is why many planning organizations are "disappointed" with SAPR. Behind this disappointment stands a whole set of problems that no one in the country is occupied with.

"Our business is to supply people with equipment," said Yu. Lapshin, a deputy department chief for computer equipment for all-union Gosplan. "The near-term task is to seat three million people at ARMs, employed in the spheres of management and planning."

But GKNT adheres to a directly contradictory point of view.

"Well, we can smother planners and administrators with ARMs, but what's the point?" shrugged department chief V. Boyko. "They still have to know how to use them, constantly seeking out new possibilities. It is not for nothing that international conferences on SAPR are held every year, where specialists can exchange experience. Our departments have not once sent their employees: they are conserving foreign currency. If you buy an instrument, then no problem... But if after every conference the firms participating in it obtain real profits, no one is concerned."

A simple example: SAPR, as a rule, makes a plan 20-30 percent more expensive. But this is recouped many times over in the future--a good plan makes possible a considerable economy of materials and human and power resources and reduces construction times and operating expenditures. The economy is enormous overall. It would seem that for any problems, we at once dig out funds from one pocket--the state. But planning organizations are obligated to achieve a reduction in the cost of plans, and they have their own reporting. Moreover, SAPR is not entered in modern financial planning: it was not envisaged what funds would support it. But that is still not all. A cost reduction is also not beneficial to builders and operators: the one is given large volumes of work, and the other high operating expenditures within which it is easy to maneuver. That is how the paradox of the communicating vessels is obtained, in which, flouting all the laws of physics, the water stands at different levels.

Herein lies the root of the problem. How to join the vessels so as to establish a uniform level of departmental interests? How to provide automated planning systems with an "open road" not for the sake of "favorable" percentages, but for the cause? The answer suggests itself: place the

problem of SAPR into the channel of unified management. Create a cooperative center and grant it special powers that would permit it to develop a unified general policy for SAPR ideology and technology that is appropriate for all sectors. With only one condition: that this general policy bring domestic SAPR to the world level with further prospect of overtaking it. The GKNT or the recently created USSR State Committee for Computer Technology and Information Science could become this center. The interested participation of all-union Gosplan or the USSR Academy of Sciences would permit the rapid placement of SAPR on the solid rails of acceleration.

12821

CSO: 1823/324

INDUSTRY PLANNING AND ECONOMICS

RETOOLING DELAY CAUSES, EFFECTIVE CAPITAL USE EXAMINED

Kiev EKONOMIKA SOVETSKOY UKRAINY in Russian No 8, Aug 86 pp 70-72

[Article by docent and Candidate of Economic Sciences V. Shudra: "Effectiveness of Modernizing Machine Building Enterprises"]

[Text] The degree of productive capital replacement on a qualitatively new technological base is a key condition for increasing public production effectiveness. The share of funds allotted in the current five-year plan for retooling and modernizing active enterprises must exceed 50 percent of the total volume of productive capital investments. The political report of the CPSU Central Committee to the 27th Party Congress noted that the intention was to direct more than 200 billion rubles of capital investments to modernizing and retooling industry. The technical level of industry depends on how this money will be used and this means the rate of scientific and technical progress and the economic growth of the country. The use of these funds to replace obsolete equipment with new weapons of labor, systems and machine complexes answering modern requirements will permit an intensification of industrial production and an increase in production quality.

To assess the level of fixed productive capital replacement depending on its form of reproduction (retooling, modernization, expansion) and the effectiveness in using funds allotted for these purposes, we did a comparative analysis of the ratio of fixed productive capital growth rates, including its active and passive parts, as well as the levels and forms of its replacement for a group of 98 machine building and metal processing enterprises of Kiev for the years 1971-1984.

The group of enterprises which we examined includes both large plants equipped with modern highly productive equipment and small, old enterprises. The OPF/fixed productive capital/ of the plants fluctuates from 2.8 million to 71.5 million rubles, i.e., the large enterprises have a 25-fold excess of OPF over the small ones. The enterprises were grouped by production apparatus growth rates in order to show the trends in fixed productive capital replacement (see table 1).

Table 1. Grouping of Machine Building and Metal Processing Enterprises Examined by OPF Growth Rates for the Years 1971-1984

Группы предприятий (1)	Прирост ОПФ (%) (3)	Число предприятий в группе (единиц) (%) (6)	Прирост ОПФ до группы (%) (7)			Средний ежегодный процент (11)		Отношение выбытия к вводу (%) (14)
			всего (2)	в том числе (8)		ввода в действие (12)	выбытия ОПФ (13)	
				активная часть (9)	пассивная часть (10)			
I	до 50 (4)	$\frac{42}{42,8}$	31,7	53,5	18,6	4,78	1,77	37,1
II	50—150	$\frac{45}{45,9}$	87,3	85,9	108,4	8,45	2,57	30,4
III	150—250	$\frac{6}{6,1}$	184,2	167,3	310,8	14,42	1,43	10,0
IV	более 250 (5)	$\frac{5}{5,1}$	438,5	268,4	740,4	33,01	2,48	7,4
Всего: (2)		$\frac{98}{100,0}$	84,0	80,1	68,9	9,02	2,57	28,4

Key:

- |   |   |
|---|---|
| 1. Enterprise groups                                      | 8. Including  |
| 2. Total  | 9. Active part  |
| 3. OPF growth (in percentage)                             | 10. Passive part  |
| 4. Up to 50   | 11. Average yearly percentage                           |
| 5. More than 250  | 12. Introduction  |
| 6. Number of enterprises in group (units over percentage) | 13. OPF withdrawal                                      |
| 7. OPF growth by group (in percentage)                    | 14. Ratio of withdrawal to introduction (in percentage) |

An ever greater difference between the growth rates of its passive and active parts is observed in proportion to an increase in OPF growth rates. An excess in the growth rates of the active part of fixed capital over the rate of increase of its passive part is characteristic of group I enterprises only. The growth rates of the active part of OPF is lower than the growth rates of its passive part at group II enterprises. A high OPF growth rate at group III enterprises is accompanied by a further increase in the gap between the growth rates of the active and passive parts of capital. The greatest fixed productive capital growth is observed at group IV enterprises where the passive part has a 2.75-fold increase over the active. Since the predominance of work on reproducing active and passive parts of capital is the characteristic sign of retooling, modernization, and expansion of fixed productive capital as forms of its reproduction, the data we have examined on the inspected enterprises allow us to make the following conclusions. Retooling

was the predominant form of fixed capital reproduction at group I enterprises for the period examined. Equipment was replaced on a priority basis and bottlenecks were eliminated at enterprises of this group. At group II enterprises retooling was accompanied by elements for modernizing active shops. Modernization as the main form of fixed production capital reproduction is characteristic of group III enterprises. Shops and buildings have been redesigned and obsolete and worn-out structures have been demolished and replaced here. Fixed productive capital reproduction has been accomplished at group IV enterprises (which are mainly test and experimental plants) by broadening it through the construction of new and the expansion of existing shops which has led to a significant growth in the area under construction.

OPF has grown annually by an average of 2.5 percent at group I enterprises where mainly retooling has been carried out. Moreover the average yearly introduction of OPF has been 4.78 percent and withdrawal--1.77 percent, i.e., in the total replacement process withdrawal recovery has been 37.1 percent. At group II enterprises, where retooling has been accompanied by modernization elements, the withdrawal recovery amounted to 30.4 percent of total replacement. An increase in OPF rate of growth, characteristic of the modernization and expansion of operating enterprises, has led to a significant decrease in the share of withdrawal in total replacement; the replacement of OPF withdrawal to its introduction has amounted to only 7.4-10 percent.

In proportion to an increase in OPF rates of growth, there is a worsening of its technological structure due to an accelerated increase of the passive part and there is a decrease in the replacement level because of the replacement of worn-out and obsolete machinery. Consequently, one of the major goals of modernization--the accelerated replacement of the production apparatus of the enterprises (see table 2)--is not achieved.

Data on changing the average age of operated equipment testify to this. At group I enterprises where the retooling of production has been carried out, average equipment age decreased from 13.25 to 10.09 years. With a speed-up in OPF growth, the equipment park "rejuvenation" process is slowing down or completely ceasing. The average equipment age at group II enterprises has practically not changed and amounts to 12.3 years, and at group III and IV enterprises it has increased from 12.4 to 14.6 and 11.2 to 12.3 years respectively.

The inefficient use of capital when modernizing and expanding operating enterprises has not allowed an intensification in the production process through an increase in production yield per square meter of total space of all covered buildings and a rise in capital-output ratio. Only at group I and II enterprises, where retooling is going on, a significant growth in production yield per square meter of space is being observed. At group III and IV enterprises, this indicator has either increased very insignificantly or has decreased. The growth in capital-output ratio for the period under investigation at group I and II enterprises was 13.5-22.4 percent (the average for group I enterprises--19.9 percent, and for group II enterprises--15.3 percent). A decrease in capital-output ratio amounting to 26.1-78.7 percent occurred at group III and IV enterprises (the average for group III enterprises--54.6 percent, and group IV--38.2 percent).

Table 2. Change in Indicators Characterizing OPF Reproduction Effectiveness

Группы предприятия (1)	Средний возраст оборудования по группе (лет) (2)		(4)	(5)
	1970 г. (3)	1984 г. (3)	Средний съем продукции с 1 м <sup>2</sup> крытой площади (1984 г. % к 1970 г.)	Средняя фондотдача (1984 г. в % к 1970 г.)
I	13,2	10,0	161,3	119,9
II	12,5	12,3	139,4	115,3
III	12,4	14,6	104,5	54,6
IV	11,2	12,3	71,6	38,2

Key:

1. Enterprise groups
2. Average equipment age by group (in years)
3. Year
4. Average production yield per square meter of covered space (the 1984 figure as a percentage of 1970)
5. Average capital-output ratio (the 1984 figure as a percentage of 1970)

The data presented testify to the ineffective use of capital to modernize and expand operating enterprises. Worn-out and obsolete equipment is not being removed from production which causes a hypertrophied growth in repair work expenses, does not permit the freeing of personnel for use at work places equipped with modern equipment, and restrains the use of highly productive equipment which is operating in tandem with the obsolete.

The need to intensify the replacement of the machine building production apparatus through a considerable increase in the share of obsolete equipment withdrawal and a limitation on the introduction of additional (above those withdrawn) labor assets causes an immediate and ever-growing direction of assets toward retooling and modernizing enterprises. These assets will have a proper yield only if they serve as the basis for a qualitative improvement in the technical base of existing production and for an appropriate limitation on the amount of new construction and enterprise expansion. The recovery level of OPF withdrawal in its total replacement must be no lower than 30-40 percent which will permit a significant improvement in such production indicators as capital-output ratio and production yield per square meter of covered production building space and the age make-up of the machinery park.

The expansion of economic independence and an increase in the economic motivation of industrial enterprises resulting from their own activities is a major condition in providing for the effective utilization of assets directed at modernization and retooling. The work of the enterprises, based on the principles of self-financing and paying their own way will permit, on the one hand, the mobilization of internal sources to increase production effectiveness and, on the other hand, will heighten the exacting attitude of enterprises toward the technical level of the modernization projects planned.

Significant reserves for increasing effectiveness in using capital allotted for modernization can be introduced today within the present five-year plan by assessing the projects developed from the point of view of their conformity to the goals of accelerating scientific and technical progress and of refusing to carry out retooling and modernization projects which are contrary to requirements.

The measures planned to improve the economic mechanism in the machine building complex and the switch to genuinely economic methods for managing industry based on strengthening the role of general indicators and norms (such as profit, labor productivity growth, the decrease in material and power intensity of production) are placing a barrier in the path of ineffective enterprise modernization and retooling projects since the enterprises, not the administrative organs, will have the last word when deciding on carrying out appropriate reproduction measures. Motivating enterprises to increase qualitative production indicators will allow a broader use both of their own assets and of bank credit for modernization and retooling, thereby limiting the amount of centralized capital investments given, not subject to replacement, by the state. These assets can be used to carry out large-scale measures for developing the latest goods in the electronic industry and instrument building--for the output of microprocessors and computers, robots, etc.

8524  
GSO: 1823/09

INDUSTRY PLANNING AND ECONOMICS

PARTY CONFERENCE VIEWS TASKS FOR ADVANCEMENT OF MACHINE BUILDING

Moscow PRAVDA in Russian 9 Aug 86 p 2

[Abstract] The full-page article summarizes proceedings of a conference which took place in the Central Committee of the Communist Party of the Soviet Union on 8 August. The conference assessed progress in modernizing machine building and improving the quality of its products in line with party directives, and it surveyed tasks which remain to be accomplished in this connection.

Summaries are given of opening and closing remarks by L.N. Zaykov, member of the Politburo of the Central Committee, and of reports and speeches by other participants in the meeting. Zaykov mentioned a number of major problems which he said are closely connected with the status of machine building, including strengthening the country's defense capability and improving the performance of the Soviet economy. He noted that machine-building enterprises are handicapped by antiquated equipment, in particular. In his concluding remarks, Zaykov mentioned that machine building has been set the task of bringing its main products up to the standard of the highest world achievements, in 1991-1993. He summarized the conference's discussion of guidelines for achieving this and other objectives, focusing attention on tasks for improving planning, organization, resources, economic incentives and personnel training in industry, design work and R&D, and expanding scientific-technical cooperation with foreign countries.

Among the other speakers were Yu.D. Maslyukov and I.S. Silayev, deputy chairmen of the USSR Council of Ministers, who reported on recent measures to improve performance and management organization in machine building. P.I. Radchenko, general director of the "Elektronmash" (electronic machinery) Research and Production Association in Leningrad, advocated measures to improve the work organization and pay of engineering and technical personnel. V.P. Belyakov, general director of the "Kriogenmash" (cryogenic machine building) Research and Production Association, discussed the advantages of large-scale industrial organization for speeding scientific-technical progress. A.P. Aleksandrov, president of the USSR Academy of Sciences; A.F. Kamenev, deputy chairman of the USSR State Committee for Science and Technology; and Academician K.V. Frolov urged closer cooperation between scientists and industrial personnel in defining main guidelines for scientific-technical progress. G.K. Mirzoyev, chief designer of the Volga Automotive Plant;

G.V. Novozhilov, general designer of the Design Bureau imeni Ilyushin; and other leading designers shared experience with broadening the use of scientific and technical achievements in development of new products.

Speakers called attention to problems which they said are lowering the quality of Soviet machine-building products, particularly products of the machine-tool building, instrument building and automation, and electrical equipment industries. Criticism was directed at the existing system for certifying the quality of products, at research and design organizations which continue to copy obsolete foreign technology, and at inappropriate use of specialists by industry science. Speakers complained that chief institutes do not bear enough responsibility for the quality of equipment in production. They called for steps to increase the impact of industry science on product quality and industry planning strategy, to improve industry's electronic and automation equipment and to speed the introduction of microprocessor technology in particular.

FTD/SNAP  
/6091  
CSO: 1823/12

INDUSTRY PLANNING AND ECONOMICS

NEW BUREAU FOR MACHINE BUILDING STRESSING DIRECT TIES

Moscow PRAVDA in Russian 1 Sep 86 p 4

[Article by A. Krushinskiy]

[Extract] Hundreds of associations, enterprises and scientific research institutions of countries which belong to the Council for Mutual Economic Assistance (SEV) now have new concerns that are not very familiar ones. This is especially true of ones that are involved in machine building production.

The growing scope of this important work was particularly evident at the headquarters of the USSR Council of Ministers' Bureau for Machine Building. There a section has been created for economic and scientific-technical cooperation with SEV member-countries and for export-import, and its workers these days are wholly absorbed in coordinating activity that the machine building ministries have undertaken to establish direct ties of their associations and enterprises with partners in fraternal countries.

"A particular difficulty of this preparatory phase is the fact that these direct partnership relations are being established not merely for the sake of appearances and nice slogans, but for achieving a concrete, practical goal," said V. Anikin, the head of this sector. "After all, we have as our agenda the steady implementation of the Comprehensive Program of Scientific-Technical Progress of SEV Member Countries up to the Year 2000, which involves moving from purely trade relations to extensive specialization and cooperation of production.

"As of 1 July in all of the 11 all-union ministries that comprise the machine-building complex, 139 associations, enterprises and organizations had established direct ties with partners in SEV member-countries. In the 2 months since then, 118 more have been added to this list, and another 99 proposals are being worked out. I would like to point out something in this regard: Whereas in the past direct ties sometimes amounted to little more than trips of delegations and sharing of experience, the intention now is to advance them to a qualitatively new stage: solid cooperation in production, right down to creating enterprises with jointly held property. The leader with respect to numbers is the Ministry of the Machine Tool and Tool-making Industry: more than 40 of its enterprises and organizations have

partnerships of direct ties, and it also has the largest number of jointly held enterprises--12; some of them are in the process of being established, while others are already functioning, for example, the Soviet-Bulgarian Research and Production Association. Seven more are in the process of negotiations."

"What is the attitude of enterprise directors toward the new possibilities that are being opened up for them?"

"In the past when directors would hear the criticism that rather little of their output was exported, often they would point the blame at the Ministry of Foreign Trade, saying that it was this ministry's concern. Now the directors themselves must be seriously concerned with problems of exporting. One of the most important requirements of the machine building ministries now is: produce high-quality goods, sell them on the foreign market and earn hard currency."

FTD/SNAP

/6091

CSO: 1823/12

METAL-CUTTING AND METAL-FORMING MACHINE TOOLS

WORK ON HIGH-PRECISION MEASURING SYSTEMS FOR MACHINE TOOLS

Vilnius SOVETSKAYA LITVA in Russian No 169, 23 Jul 86 p 4

[Article by R. Chesna]

[Extract] Soviet industry has begun to produce intricate and costly measuring instruments which formerly had to be purchased in Great Britain, France and Italy. A large portion of this equipment was developed at the Vilnius affiliate of the Experimental Scientific Research Institute of Metal-Cutting Machine Tools and this affiliate's experimental plant "Pretsizika."

"Measurements have now become one of the most common technological operations," noted Candidate of Technical Sciences Algis Gapshis, director of the institute's Vilnius affiliate.

Scientists showed me high-precision encoders which have been developed at the affiliate. Measuring systems are based on these instruments. Some of them easily fit into one's hand, while others are somewhat larger. Installed in machine tools with programmed control, they enable workers to machine parts with a precision of a few thousandths of a millimeter and to avoid spoilage. Enterprises of Vilnius, Orsha and Moscow have begun producing these measuring instruments.

And here was a new coordinate-measuring machine, the latest in a series that designers of the affiliate and the "Pretsizika" plant have been developing.

Parts with intricate shapes are placed in this machine. The operator presses a button, and a special arm with sensitive, needle-like "fingers" glides gently over the surface of the machine. In a matter of seconds, a printing device prints out hundreds of measured parameters and indicates any deviations from the standard.

The developers of this new equipment are expanding their ties with industry. A program for developing and measuring flexible production systems is being implemented jointly with the "Zhalgiris" machine-tool building plant in Vilnius.

There are still many obstacles on this path, however. The problem of bringing the plans and specifications of new machines and equipment into agreement

still has not been solved. Designers of the institute thus have had to call upon various organizations of the country and of the republic literally hundreds of times to coordinate the plans and specifications of comparatively simple machine tools, which in no way promotes the acceleration of scientific-technical progress.

FTD/SNAP  
/6091  
CSO: 1823/12

METAL-CUTTING AND METAL-FORMING MACHINE TOOLS

ELECTROPHYSICAL AND COMBINED MACHINING METHODS

Moscow NTR: PROBLEMY I RESHENIYA in Russian No 13, 8-21 Jul 86 p 7

[Article by V.S. Belov, doctor of technical sciences, professor, general director of research-and-production association "ENIMS"]

[Abstract] The author discusses electrophysical and combined machining methods. An editorial preface to the article mentions that Moscow recently hosted the International Symposium on Electrical Machining Methods "ISEM-8," and that a large number of papers presented there were by specialists of the Experimental Scientific Research Institute of Metal-Cutting Machines (ENIMS), which is the country's chief organization for electrophysicochemical and combined methods of machining.

The author explains these machining methods take in electron-discharge, laser, plasma and electron-beam machining, as well as combined methods that involve ultrasonic, electrochemical, abrasive and other processes. He reports that the country's industry is producing flexible modules for these types of machining which are equipped with microprocessor control and mechanisms for automatically replacing electrode-tools. Licenses for this technology have been sold in France, Switzerland and other countries.

FTD/SNAP  
/6091  
CSO: 1823/12

METAL-CUTTING AND METAL-FORMING MACHINE TOOLS

AUTOMATION AT PRECISION-CASTING MACHINERY ASSOCIATION

Moscow TRUD in Russian No 178, 2 Aug 86 p 1

[Text] Moldavia's Precision-Casting Machinery (Tochlitmash) Production Association develops machines for precision casting which are used at hundreds of Soviet enterprises and at major machine-building firms of member-countries of the Council for Mutual Economic Aid. This equipment makes it possible to produce parts which require no further machining. Thanks to this, 45,000 foundry workers and machine-tool operators were freed from laborious operations in the country as a whole during the last 5-year plan.

The personnel of "Tochlitmash" think that still better results should now be achieved, however. The association has adopted the policy of accelerating scientific-technical progress, including progress in introducing flexible automated systems. This will make it possible to increase volume of output by 50 percent in the 12th 5-Year Plan, without increasing the number of workers.

(The photograph shows B.G. Sinyatinskiy, head of the technological laboratory of the chief technologist's department. He developed a section of robotic complexes at the association.)

FTD/SNAP  
/6091  
CSO: 1823/12

METAL-CUTTING AND METAL-FORMING MACHINE TOOLS

ROTARY VACUUM PUMP FOR TITANIUM COATING OF TOOLS

Moscow EKONOMICHESKAYA GAZETA in Russian No 34, Aug 86 p 1

[Extract] Rotary vacuum pumps have been introduced into series production at the "Vakuummash" Research-and-Production Association in Kazan', for the first time in the country. Lead time for developing and introducing this new product was shortened by a year and a half, thanks to cooperation between scientists and workers.

This new, superpowerful machine creates a high vacuum, in which titanium powder is sprayed onto tools. These products become several times stronger following this operation.

Traditional methods for scientific drafting of plans, testing of prototypes and series production were revised for the purpose of accelerating production of this highly effective equipment. The three stages were combined. Researchers began perfecting operating modes for the pump while designers were still sketching the future machine on their drawing boards. Workers prepared fixtures and proposed technological solutions of their own. Manufacturing partners in other cities of the country also took part in the project. As a result, development of the new pump was completed in one-half the time that had been specified.

Updating products is a key goal in the work of "Vakuummash" personnel. In 5 years' time, all of the items in production have been replaced with newer ones, and 17 types of unique vacuum equipment on a par with the best world models have been introduced into series production here.

FTD/SNAP  
/6091  
CSO: 1823/12

METAL-CUTTING AND METAL-FORMING MACHINE TOOLS

NEW TOOLMAKING ASSOCIATION INCLUDES ELECTRONIC GAUGES IN SETS

Moscow SOTSIALISTICHESKAYA INDUSTRIYA in Russian No 221, 23 Sep 86 p 1

[Text] The Leningrad Toolmaking Association imeni Voskov, which has just been formed, has a production orientation which will expand the output of electronic apparatus for monitoring the operation of automated machining equipment. Yesterday the first products bearing the trademark of the new firm were shipped to machine-tool builders of Moscow, Leningrad and Ivanovo.

These products are sensors for checking the operation of machine-tool modules, 'machining centers,' and mechanized lines. The devices will help maintain a stable production of new generations of machine tools, which determine progress in many branches of industry," [quotation marks as published] said Ye. Solovyev, general director of the association. "The creation of a single firm out of scattered plants opens up possibilities for supplying products in full sets. For example, sets for various types of machining aggregates will include cutting tools and measuring devices equipped with microprocessors. The combining of efforts of specialists within the framework of a single enterprise will help to shorten the cycle of new product development."

FTD/SNAP  
/6091  
CSO: 1823/12

ROBOTICS

ACADEMICIAN KOSHKIN ON NC MACHINE TOOLS, INDUSTRY RETOOLING

Moscow SOVETSKAYA ROSSIYA in Russian 29 May 86 p 2

[Interview with Academician L. N. Koshkin, Hero of Socialist Labor, by Correspondent A. Nimov: "Robots To Meet Bureaucratic Goals"]

[Text] [Question] Lev Nikolayevich, according to data from the USSR Central Statistical Administration, during 1981-1984 the USSR manufactured 33,500 NC robots. This exceeds the entire active fleet of robots in the U. S. (6,250) and Japan (13,000) in 1982. But, having manufactured more robots, we did not receive an economic gain. I would like to understand the reason for this?

[Answer] I will begin with an example, and then we will return to the robots.

The mechanized system with which coal is extracted in Donbass mines is designed for layers no less than 1.3 meters thick. But the majority of layers in the Donbass are narrower and the combine digs out dirt along with the coal. According to evaluations by economists, due to the lack of mining equipment capable of working in narrow layers the state loses up to 600 million rubles annually. And this has been going on for many years. Perhaps, in principle it is not possible to develop such a system?

"Why not?" the designers shrug their shoulders. "Back in the 1970's such a system was developed at the Donetsk Coal Institute. But it has not yet reached the stage of large scale introduction."

A number of scientists explain this "economic" cause as due to "bureaucratic" barriers and a weak production base at the developing institute. But it seems to me that this is only part of the truth. It is not persuasive to agree to write off billions of rubles in losses based solely on the sluggishness of engineers. The leaders of the USSR Ministry of the Coal Industry and USSR Gosplan must be called to account. They relied on inefficient equipment. And this situation could have been "calculated" in advance, once the necessary economic forecasts had been made. But, in making important decisions on the development of mines, the economic leaders were oriented more on volume. Until this day labor productivity is calculated according to the overall amount of fuel extracted.

[Question] What does this have to do with robots?

[Answer] This is what. In developing robot equipment we fail to do the necessary economic studies. Under the slogan "robotics will solve everything" more than 20 ministries unleashed a large scale assault on industrial robots. Considering that the majority of branches did not have either the appropriate forces or experience, the robots which they developed were not only more costly, but were ten times less reliable than the best worldwide models. Moreover, automation of already obsolete machinery through the help of robots was attempted.

As in the case of manufacturing coal combines for wide layers, the goal for which the new equipment was created was lost sight of -- that of improving labor productivity.

Decisions that were not well thought out and a lack of necessary studies also led to a situation in which during 1981-1983 and the first half of 1984, 1.3 times more robots were produced than the plan target called for, but only 55 percent were placed in operation. But even many of those which received authorization to be delivered to enterprises did not demonstrate the required effectiveness.

The U. S. and Japan acted differently. First they studied the demand for robots and determined which of them were "profitable," and only then did industry embark upon their production.

[Question] Does this mean that we could have avoided many errors if the development of production had taken place in accordance with a scientifically based plan?

[Answer] That is entirely correct. It seems to me that in selecting a strategy for the development of industrial equipment we still have left much to be considered. Some scientists and economic leaders do not take into account the importance of the most important index of industrial development -- labor productivity -- and do not wish to examine equipment from the standpoint of savings.

About a quarter century ago, when sufficiently powerful and relatively inexpensive computers appeared, designers in the West talked about plans for creating automated factories, processes which do not require people, or, as they began to be called, flexible manufacturing systems (FMS). Soviet specialists were also attracted to the popular direction in machine building. It was expected that they would eliminate the work force shortage, lead to around-the-clock operation of enterprises and substantially improve product quality. Efforts to create FMS became widespread.

Years passed. However, we were unsuccessful in moving beyond individual fragments of future FMS. Of course, some NC machine tools, with a system of automated billet supply and ASU [automated control systems] affixed to them, could serve to demonstrate modern equipment. But another aspect of FMS also became clear through this. Even their propagandists were forced to note the

"high capital intensity" and "substantial expenditures for information control systems" (which, naturally, are not production elements of the equipment), and in the end to say that "we cannot yet even talk about obtaining economic savings from MFS..." According to an analysis carried out by USSR GKNT [State Committee of the USSR Council of Ministers for Science and Technology], the creation of new FMS will lead to costs of 35 billion rubles and in return to the freeing of only 600,000 workers.

Study of the effectiveness of MFS leads to the discomfoting conclusion of their economic inexpediency. This occurred because, during development of the concept the main objective of developing industrial equipment was replaced. Instead of raising labor productivity (increasing production per unit of one-time and operating expenses) the idea of "flexibility" of production became inserted in the FMS (i.e., that of rapid replacement of one product being manufactured by another) and of automation "ignoring costs." As a result, the achievements of the 20th century -- computers -- began to be adapted to old machine tools. But can you "fly far on a ball of soap," even if you attach a jet engine to it? We replaced the worker who made five parts per day at a machine tool with a robot, controlled by a computer. It is true that from this the machine tool became ten times more costly, but the mark "automated" was entered into reports. But, you see, those hundreds of thousands of rubles by which the cost of the machine tool increased are enough to pay the worker's wage for 50 years.

[Question] Lev Nikolayevich, one might gain the impression that you oppose automation of production.

[Answer] No. I am against attempting to solve new tasks on an old technological base. What do I have in mind?

In the development of industrial machinery we can point out several stages which distinguish the relationship among the most important functions: transport and machining.

The first stage is represented by machinery on which the transport functions are interrupted by the machining functions. Machining requires that the part be stopped.

The second stage represents machinery on which the transport function and the machining function take place simultaneously: wire drawing and metal rolling.

The third stage is associated with rotary machines, on which both the part and the tool which is machining it are transported together during machining. (For example, this is how milk bottling at a milk factory takes place). The fourth class of machinery, most modern from the standpoint of dialectics, is distinguished by the fact that machining is carried out not only at any transport speed, but also at any density and cross section of the flow of products.

Modern automated lines which increase labor productivity many-fold are associated with the third and fourth classes of machinery. Attempts by

propagandists of FMS to place already obsolete principles into the production of the future can only retard progress.

Let us recall that in the 1940's propeller driven aircraft reached a maximum speed of 600-700 km per hour. It was necessary to find a new path of aviation development. And it was found. Jet aircraft replaced propeller driven aircraft. And planes began to fly faster than the speed of sound.

A similar situation occurred in machine building. "Jet" retooling of the branch is required. Precisely "jet" retooling, since the creation of highly effective automated lines based on technologically old mechanisms is impossible. The problems of flexibility and automation must be solved on a new technological basis; i.e., rethinking of the whole concept of the creation of new equipment is required.

Today there are still those who try to brush aside new technologies and machinery. But, it seems to me that we cannot return to the old way, restructuring has already begun. I think that the most important role in all of this work will belong to the recently created Buro of the USSR Council of Ministers for Machine Building. It is precisely this buro which is called upon to strengthen the role of the state in controlling machine building branches, to implement a unified technological policy and to determine the strategy for equipment development.

The structure of the machine building ministries is being reorganized in order to expand substantially the independence and responsibility of the primary elements -- production associations (PO) and scientific production associations (NPO). As a result, the ministries will be able to concentrate on solving the truly important problems, and on a strategy for development of the branches. The most important developments, capable of influencing scientific and technological progress as a whole, will be discussed at the technical council of the Buro for Machine Building. This will make it possible to carry out timely expert examination of machinery and mechanisms which are being developed, and to monitor the accuracy of evaluations made by lead branch institutes.

The work of modernizing machine building is already gathering speed. For example, Minstankoprom [Ministry of Machine Building] is producing 20,000 fewer machine tools in 1986 than in 1985 (a total of 130,000); but their aggregate productivity will be higher than the 150,000 made the previous year. Development and production of rotary and rotary conveyor lines will begin. Inter-branch scientific and technological complexes for industrial lasers, machine reliability and rotary and rotary-conveyor lines have been created to facilitate the most rapid introduction of new technologies and machinery.

The tasks posed to scientists and designers are complex and the time allotted to solve them is short. But, nevertheless, it is necessary to act thoughtfully, without hustle and bustle, and not forgetting Lenin's words that labor productivity is the main and most important factor for the victory of the social system.

9069

CSO: 1823/0265

ROBOTICS

UDC 52-5;621.658.2

DEVELOPMENT TRENDS IN INDUSTRIAL ROBOT CONTROL

Moscow MEKHAIZATSIIYA I AVTOMATIZATSIIYA PROIZVODSTVA in Russian No 5, May 86  
pp 21-23

[Article by Candidate of Technical Sciences L. A. Sribner and engineer Yu. V. Fridman: "The State and Development Trends of Control Devices for Industrial Robots"]

[Text] First-generation industrial robots (IR) are currently employed in industry (99 percent), of which IRs with TsPU [central control panel] devices total 65 percent. Industry is beginning to employ second-generation robots, while third-generation robots have not gone beyond experimental prototypes. Industry has recently begun to use IRs of the 2.5 generation, that is, IRs with STZ [expansion unknown], which are sometimes associated with the third generation (this association is incorrect since, aside from visual character recognition systems, these IRs do not have artificial-intelligence elements). The widespread incorporation of third-generation IRs is anticipated in the upcoming ten-year period, since computers with artificial intelligence will soon be widely employed (including in IRs and other automated equipment).

Second- and third-generation IRs, however, will not supplant the first-generation IRs, and all three generations will be employed together, since the IRs of each generation have their own economically expedient sphere of application. The first-generation IRs (programmable IRs) are employed in a completely determinate environment, that is, when all changes can be determined in advance. IRs with TsPU are employed in large-series and series production, when the equipment rarely needs to be reset. With frequent equipment resetting, IRs with NC [numerical control] are utilized. Second-generation IRs (adaptive IRs) can be adapted to a changing situation, and third-generation IRs (intelligent IRs) can make the required decisions independently. Second- and especially third-generation IRs, however, are considerably more expensive than first-generation IRs and require more qualified support personnel.

IR control devices with TsPU of the UTsM series (UTsM-10, UTsM-20, UTsM-30, UTsM-663) are manufactured in our country. They are built on the basis of automated microprogrammed units that operate on a strict cycle. The device is intended for the control of IRs and auxiliary equipment. The program makes connections on a switching field (UTsM-10), diode jacks inserted into jacks of

a collector field (UTsM-20), or with the aid of a keyboard with the recording of the program in electronic memory (UTsM-30, UTsM-663).

The more modern UTsM-100-type TsFU device is based on the K580 microprocessor set. It is constructed on the modular-unit principle and can be adapted to suit the customer. The UTsM-100 device is equipped with developed software, as well as constructed on the modular principle using a problem-oriented programming language. The TsFU device can operate in automatic, semi-automatic and set (manual) modes.

The series UPM positioning devices for IR control (UPM-331, UPM-552, UPM-772) are also constructed on the basis of automated microprogrammed units that operate on a strict cycle and contain an operational logic block that carries out the processing of logical information. The device controls IRs and auxiliary equipment. The principal distinction of the TsFU positioning devices from the NC positioning is the use of return pulse sensors in place of way trips. The positioning NC operates in the following modes: automatic, instruction, frame retrieval, program control and auxiliary.

The series UKM (UKM-552, UKM-772) and UPKM (UPKM-01, UPKM-02) IR contouring and universal control devices are constructed using Elektronika-60-type microprocessors. Their structural layouts (Fig. 1) are practically the same. They differ only in the composition of the software. The devices can be operated in the following modes: automatic, instruction, editing, control, and information exchange with programming devices.

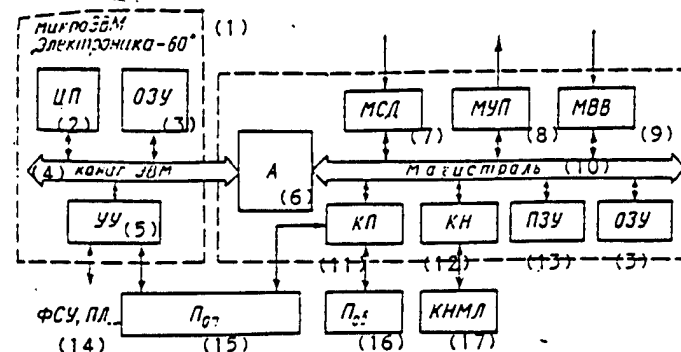

Fig. 1. Robot-control device diagram using Elektronika-60 microcomputer

Key: 1--Elektronika-60 microcomputer; 2--central processor; 3--memory; 4--computer channel; 5--control unit; 6--channel adapter; 7--sensor interface module; 8--drive-control module; 9--input-output module; 10--unibus; 11--console controller; 12--storage control; 13--read-only memory; 14--reader device; 15--operator console; 16--instruction console; 17--cassette tape unit.

The IR control devices, as a rule, are one element of a multi-level hierarchical GPS [flexible production system] control system, although it is also necessary to envisage the possibility of autonomous IR utilization. Fig. 2 presents typical examples for the inclusion of an IR control device in a

hierarchical GPS control system. In the first instance (Fig. 2-a) the IR control device forms the lowest hierarchical level of the multi-level control system. In this case, the IR control device should receive commands from a higher-level system. If the transfer of the IR from one control program to another at the command of the module control device is required, then the IR control device should have either a program unit (for example, an internal magnetic-storage unit) or the capability of recording control programs from a higher-level system.

In the second instance (Fig. 2-b), the IR control device controls not only an IR, but a machine tool (machining center) through its NC system and auxiliary equipment of the flexible automated module, which is implemented either directly or through intermediate control devices. In this case, additional requirements are made of the IR control device for simplicity in the entry of control programs by auxiliary devices. Most convenient is the entry of auxiliary-device programs in contact-relay symbols, for which the fundamental electrical circuitry of these devices should be composed from the beginning.

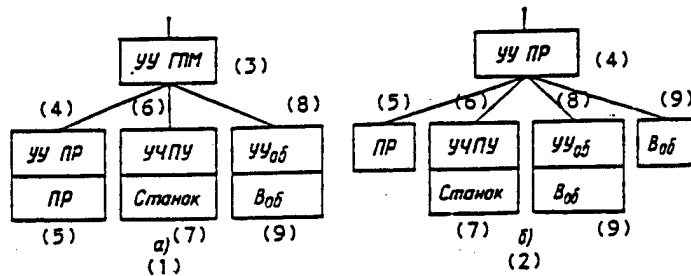

Fig. 2. Typical examples of use of industrial-robot control devices in a GPS

Key: 1--a) inclusion of IR control device in the GPM control system; 2--b) use of IR control device for controlling GPM equipment; 3--flexible production module [GPM] control device; 4--IR control device; 5--IR; 6--machine-tool control device; 7--machine tool; 8--auxiliary equipment control device; 9--auxiliary equipment.

The use of IRs in GPSs leads to higher reliability requirements on IRs and their control systems. Even a comparatively uncomplicated GPS requires that their reliability of operation be brought to a probability of failure-free IR control-device operation of 10,000-20,000 hours (wherein it is naturally assumed that the reliability of the remaining GPS components will also be increased by an order of magnitude).

Insofar as the IR control device operates as part of a multi-level GPS control system, it should have the capability of communicating with the higher-level system, which is not envisaged in a number of IR control devices.

For the possible use of IR control devices and adaptive IRs in the devices, the possibility of connecting sensor devices should be envisaged. The latter can be either with digital output or with standardized analog output of plus or minus 10 volts and should then envisage the possibility of including analog-to-digital converters. The installation of analog-to-digital converters in the device is essential for controlling the regulated or tracked electric drives (or electrical hydraulic drives).

A most important issue in constructing IR control devices is their language software, that is, the choice of programming language.

IR programming can be carried out by one of three methods: IR instruction; writing programs using IR programming language; and, using both IR instruction methods and programming language.

Instruction is accomplished by manual assignment of the required displacements of the IR working organs, which can be accomplished by the IR manual control organs or with the aid of manual motion reproduction handles. Solutions where the instruction IR models is carried out are well-known. After the control program is recorded in it, this program is used for IR control. IR instruction can be expediently utilized for the assignment of comparatively simple programs. This method is simple to implement and does not require highly qualified personnel.

With a large amount of IR programming, the instructional method requires much time and a large number of support personnel, and leads to equipment idle time in resetting.

The use of programming languages makes it possible to execute resetting with minimal equipment idle time, since the programming itself is carried out regardless of equipment operation. IR programming languages permit the use of the information of sensory devices as well as interactive signals with production equipment. The use of IR programming languages requires highly qualified personnel and specialized technical as well as programming equipment for the development of programs. The programs can be composed on other analogous equipment, corrected, supplemented, and subprograms and other structural elements included as well.

In the combined method, a control program is composed that has all of the commands and known data, and the values of the coordinates are entered into the program by the operator in the IR instruction method. In this case, the need for a qualified operator is not great, and equipment idle time in resetting is considerably less than in the use of the instructional method.

The language programming is carried out using any high-level programming language, for example the AL and SIGMA languages based on ALGOL, the SERE, MAL and VAL languages based on BASIC, the ROBEX language based on APT and FORTRAN, the APL, ML, VML and LM languages based on PASCAL, the RPL language based on LISP etc., or using specialized languages--WAVE, RAPT, AML, STROL, RVL/A and others.

IR programming languages are classified in the following groups: robot-oriented languages that permit the direct programming of IR movements; task-oriented languages in which the program describes the fulfillment of a task, that is, the required disposition of objects and actions on them, and not depending on IR design; and, problem-oriented languages in which the program assigns a specific operation that consists of a sequence of individual tasks.

Robot-oriented languages currently predominate numerically. In using task-oriented and problem-oriented languages, the planner should equip the IR control devices with jobs that convert the control program and the program into robot-oriented language.

COPYRIGHT: Izdatelstvo "Mashinostroyeniye", "Mekhanizatsiya i avtomatizatsiya proizvodstva", 1986.

12821

CSO: 1823/313

- END -