

Elimination of the Roll Bias Caused by Wrap Around Fins for the FMTI Missile

C.W. McKerley

Nichols Research Corporation

Huntsville Alabama

Abstract

The Future Missile Technology Integration (FMTI) Missile System is an attempt to design an Army tactical weapon that can effectively attack both fixed and rotary wing aircraft and armor of all types. Several 6-DOF simulations have been developed to aide in the design of this system. There is a design 6-DOF, a man in the loop (MITLS) simulation, a hardware in the loop (HWIL) simulation, and a tracker design simulation to name a few. The design 6-DOF is the highest fidelity simulation and it has been used as input to the other simulations. The design simulation is used to design the overall system requirements including hardware and software algorithms. As to be expected, the design 6-DOF has gone through many changes as the system evolved. It has become apparent that there has been a roll angle bias introduced into the roll channel of the missile. The source of this roll bias is discussed in this paper and a design is introduced to effectively eliminate or minimize its effect.

The Cause of the Roll Bias

Figure 1 shows a typical roll angle history as a function of time. The roll bias had not been noticed in previous designs and it was unclear at what point this bias had been introduced into the design. A little investigative work led to the answer. Going back as far as FMTI version II, it was noticed that the roll angle bias had been present. The roll bias was not present in version I. Several new mods had been introduced into the design simulation since FMTI version I. For instance, the aerodynamics had been updated to the new black box aero. The actuator had also been updated. And of course there have been several autopilot updates. The actuator was eliminated by running the simulation using the linear actuator model instead of the new full up model. The roll bias was still present. Since the roll autopilot topology had not changed since version I, by process of elimination it appeared that the problem had to be the new aero. Examining plots of the roll aerodynamics from reference 1, the cause of the bias became apparent. Figure 2 shows that at zero angle of attack and zero roll fin deflection there is a slight aerodynamic roll coefficient.

Thus there is a roll moment at this condition.

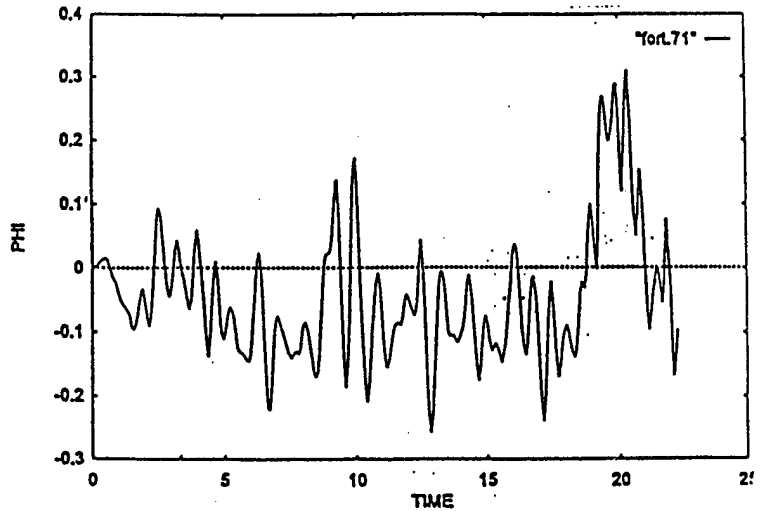

Figure 1 Typical Roll Angle Time History Showing Roll Angle Bias That Has Been Introduced Into the FMTI Design

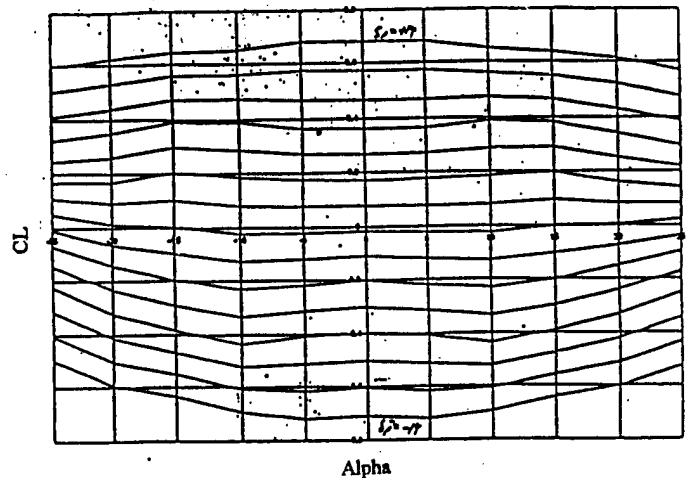

Figure 2 Aerodynamic Roll Data Showing Bias Moment at Zero Angle of Attack and Zero Roll Fin Deflection

DTIC QUALITY INSPECTED 3

1998 1127 030

Analysis

The equation for the roll angular rate as a function of the applied rolling moments becomes

$$Cl_\delta \delta QSD + Cl_p \frac{QSD^2}{2v} + Cl_o QSD = I_{xx} \dot{p} \quad (1)$$

Dividing through by the moment of inertia and making the appropriate definitions, the differential equation relating the roll rate to the fin deflection and bias moment becomes

$$L_\delta \delta + L_p p + L_o = \dot{p} \quad (2)$$

During cruise the dynamic pressure is about constant for near constant velocity and near constant altitude. Thus all the aerodynamic terms in this equation are about constant. Taking the LaPlace transform of the above equation making the near constant dynamic pressure assumption, the following relationship results.

$$p(s) = \frac{L_\delta \delta(s)}{s - L_p} + \frac{L_o(s)}{s - L_p} \quad (3)$$

The topology for the roll autopilot is shown below in figure 3. Note how the bias acts as a disturbance to the roll rate part of the autopilot. If the roll rate compensation is changed to a proportional plus integral (PI) type, then a near constant disturbance moment has no effect on the roll rate. This is because the constant moment is effectively differentiated. A differentiated constant yields zero. Thus the rate command p_c has the desired effect with the effect of the bias being nullified.

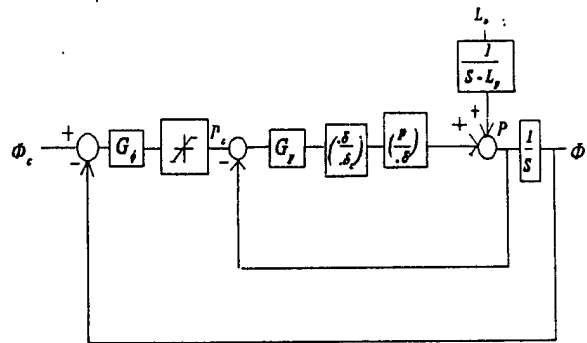

Figure 3 Roll Autopilot Block Diagram

In order to do a design, the transfer function from fin deflection in to roll angular rate must be known as well as a representative fin deflection per fin deflection command transfer function. Table 1 shows roll rate transfer functions at several different velocities. The fin deflection per fin command to be used in this design is also shown below. The design will be performed for a velocity of 500 ft/sec and then modifications will be added to account for velocity variation.

Velocity(ft/sec)	Roll Rate Transfer Function
100	$\left(\frac{p}{\delta}\right) = \frac{44.89}{s + .54}$
300	$\left(\frac{p}{\delta}\right) = \frac{404.06}{s + 1.62}$
500	$\left(\frac{p}{\delta}\right) = \frac{1122.4}{s + 2.70}$
700	$\left(\frac{p}{\delta}\right) = \frac{2199.9}{s + 3.77}$
900	$\left(\frac{p}{\delta}\right) = \frac{3636.6}{s + 4.85}$
1100	$\left(\frac{p}{\delta}\right) = \frac{5432.4}{s + 5.93}$

Table 1 Airframe Roll Rate Transfer Functions

$$\left(\frac{\delta}{\delta_c}\right) = \frac{35530}{s^2 + 265s + 35530} \quad (4)$$

Since the sample rate used for the autopilot in this system is 600 Hz, s plane techniques can be used in the design. Figure 4 shows the root locus for the rate loop without compensation and Figure 5 shows the root locus for this loop with a PI controller present. The PI controller has the form shown below. Of course the filter will be implemented into the autopilot as a digital filter. A tustin transformation is used to transform from the s domain to the z domain.

$$G_p(s) = k_3 \frac{(k_1 s + k_2)}{s} \quad (5)$$

An integral part of the rate loop filter is the variable gain k_3 (ROLGAN). This gain is scheduled as a function of the estimated missile velocity (VMEST) calculated by the navigator. A sketch of the gain history is shown below in figure 6. The compensation G_ϕ is set to 1 at present.

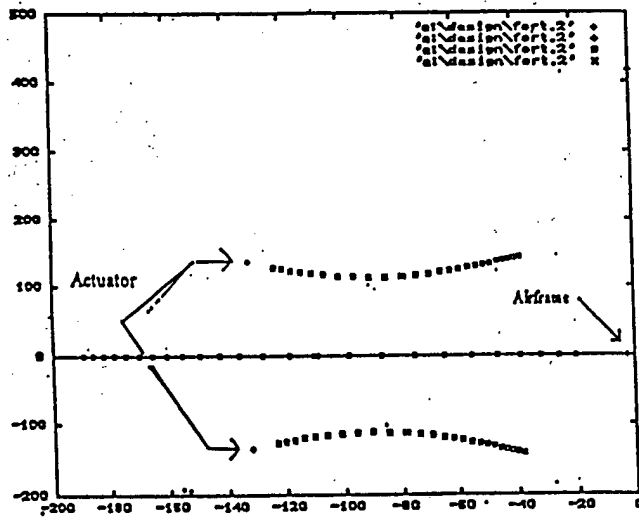

Figure 4. Root Locus for Uncompensated Roll Rate Loop

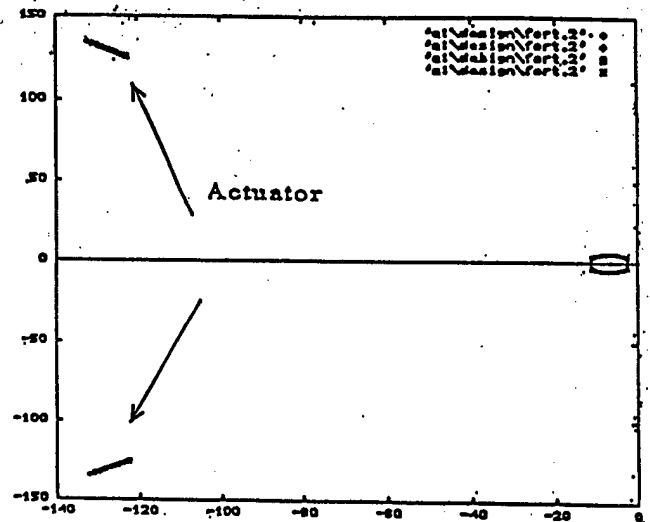

Figure 5.A Root Locus for the Compensated Roll Loop Using PI Controller

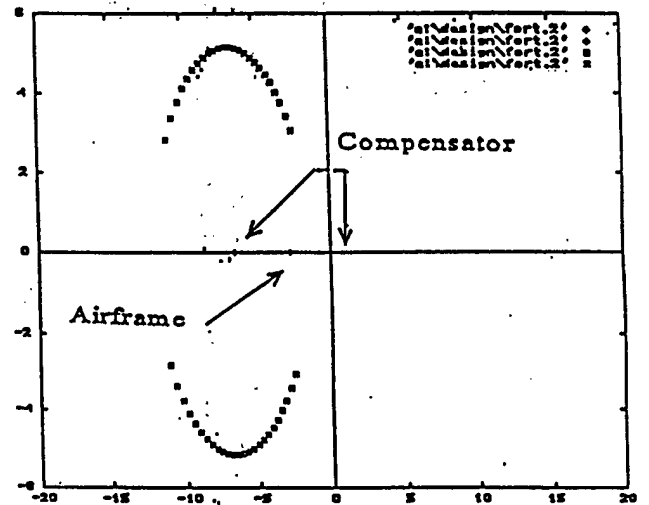

Figure 5.B Close Up of Compensation with Airframe Pole

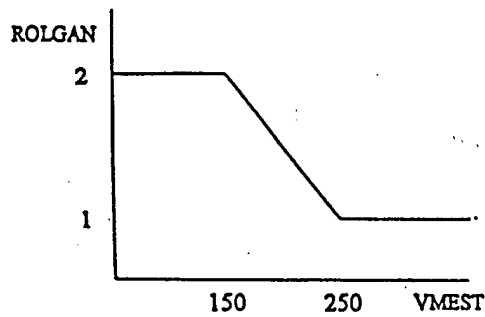

Figure 6. Roll Filter Gain as a Function of VMEST

Results

Figure 7 shows a typical roll angle history with this new compensation. Note that the roll bias has been effectively eliminated. The roll angle is not perfectly symmetrical about zero since some of the fin is used to control the pitch and yaw channels as well as roll.

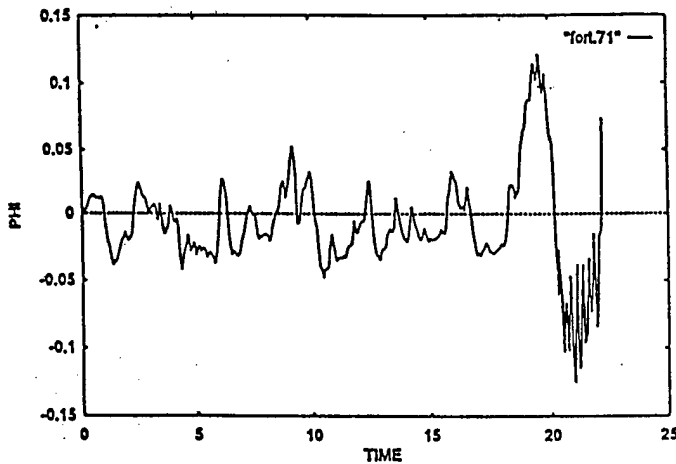

Figure 7. Typical Roll Angle Time History Showing Effective Elimination of Bias

Conclusions

The subject of disturbance accommodation control (DAC) has been around for some time and there are

several techniques for approaching the problem². If a disturbance has piecewise constant wave form, the typical DAC solution reveals (after much analysis) what the classical control engineer has known for some time. That is a free $1/s$ in the feedback path will effectively eliminate the disturbance. A real world problem has been presented that has this form of disturbance. The effective solution has been shown to be a PI controller. For this case, the PI controller allowed the commanded roll rate to be achieved while the aerodynamic bias has been effectively eliminated.

References

- [1] Hall, Robert; McKerley, C.W.; Schneider, Tom; "Support for the Design and Analysis of FMTI G&C Systems", NRC Technical Report N-TR-97-128, 23 February, 1997.
- [2] Johnson, C.D. "Theory of Disturbance-Accommodating Controllers", Control and Dynamic Systems, Advances in Theory and Application, Vol 12, 1976.

Glossary

Symbol	Definition	Units
Cl_δ	Roll Driving Derivative	Per Rad
δ	Fin Deflection Angle	Radian
p	Missile Roll Rate	Rad/sec
Q	Dynamic Pressure	Lb/ft^2
Cl_p	Roll Damping Coefficient	Per Rad
D	Aero Reference Length	ft
Cl_o	Roll Bias coefficient	-----
S	Aero Reference Area	ft^2
I_{xx}	Roll Moment of Inertia	Slug- ft^2
L_δ	$\frac{Cl_\delta QSD}{I_{xx}}$	Per sec ²
L_p	$\frac{Cl_p QSD^2}{2vI_{xx}}$	Per sec
L_o	$\frac{Cl_o QSD}{I_{xx}}$	Rad/sec ²

AIAA 1998 Missile Sciences Conference

FOR THE FMTI MISSILE

Title of Document ELIMINATION OF THE ROLL BIAS CAUSED BY WRAP AROUND FINS

PLEASE CHECK THE APPROPRIATE BLOCK BELOW:

- _____ copies are being forwarded. Indicate whether Statement A, B, C, D, E, F, or X applies.
- DISTRIBUTION STATEMENT A:
APPROVED FOR PUBLIC RELEASE: DISTRIBUTION IS UNLIMITED
- DISTRIBUTION STATEMENT B:
DISTRIBUTION AUTHORIZED TO U.S. GOVERNMENT AGENCIES ONLY; (Indicate Reason and Date). OTHER REQUESTS FOR THIS DOCUMENT SHALL BE REFERRED TO (Indicate Controlling DoD Office).
- DISTRIBUTION STATEMENT C:
DISTRIBUTION AUTHORIZED TO U.S. GOVERNMENT AGENCIES AND THEIR CONTRACTORS; (Indicate Reason and Date). OTHER REQUESTS FOR THIS DOCUMENT SHALL BE REFERRED TO (Indicate Controlling DoD Office).
- DISTRIBUTION STATEMENT D:
DISTRIBUTION AUTHORIZED TO DoD AND U.S. DoD CONTRACTORS ONLY; (Indicate Reason and Date). OTHER REQUESTS SHALL BE REFERRED TO (Indicate Controlling DoD Office).
- DISTRIBUTION STATEMENT E:
DISTRIBUTION AUTHORIZED TO DoD COMPONENTS ONLY; (Indicate Reason and Date). OTHER REQUESTS SHALL BE REFERRED TO (Indicate Controlling DoD Office).
- DISTRIBUTION STATEMENT F:
FURTHER DISSEMINATION ONLY AS DIRECTED BY (Indicate Controlling DoD Office and Date) or HIGHER DoD AUTHORITY.
- DISTRIBUTION STATEMENT X:
DISTRIBUTION AUTHORIZED TO U.S. GOVERNMENT AGENCIES AND PRIVATE INDIVIDUALS OR ENTERPRISES ELIGIBLE TO OBTAIN EXPORT-CONTROLLED TECHNICAL DATA IN ACCORDANCE WITH DoD DIRECTIVE 5230.25. WITHHOLDING OF UNCLASSIFIED TECHNICAL DATA FROM PUBLIC DISCLOSURE. 6 Nov 1984 (Indicate date of determination). CONTROLLING DoD OFFICE IS (Indicate Controlling DoD Office).
- This document was previously forwarded to DTIC on _____ (date) and the AD number is _____.
- In accordance with provisions of DoD instructions, the document requested is not supplied because:
- It will be published at a later date. (Enter approximate date, if known).
- Other. (Give Reason)

19981127 030

DoD Directive 5230.24, "Distribution Statements on Technical Documents," 18 Mar 87, contains seven distribution statements, as described briefly above. Technical Documents must be assigned distribution statements.

Print or Type Name

Telephone Number

Authorized Signature/Date

(SEE ATTACHED)

AMSAM-RD-

MEMORANDUM FOR AMSAM-PA

SUBJECT: Originality and Uniqueness, OPSEC Review and MCTL Determination # 814 for Material Being Released to the Public

for the FMTI MISSILE

1. IDENTIFICATION OF MATERIAL

Title of Material: ELIMINATION OF THE ROLL BIAS CAUSED BY WRAP AROUND FI

Author(s)/Office Symbol: NICHOLS RESEARCH CORP

Check One:

- Technical Report - give report number: _____
- Open Literature - give title of journal: _____
- Presentation - give date and place to be presented: NOV 17-19, 98 Monterey CA

2. ORIGINALITY AND UNIQUENESS REVIEW (By a person in authority over originator)

Subject material has been reviewed and determined to be factual and unclassified. The subject material has been reviewed for originality and uniqueness and this information has been found:

- not to contain original and unique material.
- to contain original and unique material and requires patent evaluation by the Intellectual Property Law Division of the Legal Office before release.

Walter E. Jordan, Jr
SIGNATURE

27 Aug 98
DATE

256-876-3015
TELEPHONE NUMBER

NAME AND TITLE

AMSAM-RD-MG-GA
OFFICE SYMBOL

3. OPSEC REVIEW (By a designated directorate/office OPSEC reviewer).

"I, the undersigned, am aware of the hostile intelligence interest in open source publications and in the subject matter of the information I have reviewed for OPSEC purposes. I certify that I have sufficient technical expertise in the subject matter and that, to the best of my knowledge, the net benefit of this public release outweighs the potential damage to the secrecy of all AMCOM, AMC, Army, or other DOD programs of which I am aware."

William C Pittman
SIGNATURE WILLIAM C PITTMAN

28 Aug 98
DATE

256-876-177
TELEPHONE NUMBER

NAME AND TITLE

AMSAM-RD-MG-JM
OFFICE SYMBOL

4. MILITARY CRITICAL TECHNOLOGIES LIST (MCTL) DETERMINATION (By AMSAM-RD-TI)

The subject material does not concern the technology items of the MCTL.
 The subject material does not concern the technology items of the MCTL since it relates to _____ and does not relate to technologies of _____ as covered in MCTL paragraph _____

Recommend local approval for public release.

Steven P. D. Smith
SIGNATURE DATE

STEVEN P. D. SMITH/876-4600/AMSAM-RD-TI

5. CLEARANCE ACTION

Subject material has been: APPROVED or DISAPPROVED for public release.

Steven P. D. Smith
Technology Integration Office, MRDEC, USAAMCOM DATE