

259092

JPRS-UMM-86-013

1 AUGUST 1986

USSR Report

MACHINE TOOLS AND METALWORKING EQUIPMENT

CLASSIFICATION STATEMENT A
Approved for public release;
Distribution Unlimited

19981123 021

DTIC QUALITY INSPECTED 3

FBIS FOREIGN BROADCAST INFORMATION SERVICE

REPRODUCED BY
NATIONAL TECHNICAL
INFORMATION SERVICE
U.S. DEPARTMENT OF COMMERCE
SPRINGFIELD, VA. 22161

4
62
A04

NOTE

JPRS publications contain information primarily from foreign newspapers, periodicals and books, but also from news agency transmissions and broadcasts. Materials from foreign-language sources are translated; those from English-language sources are transcribed or reprinted, with the original phrasing and other characteristics retained.

Headlines, editorial reports, and material enclosed in brackets [] are supplied by JPRS. Processing indicators such as [Text] or [Excerpt] in the first line of each item, or following the last line of a brief, indicate how the original information was processed. Where no processing indicator is given, the information was summarized or extracted.

Unfamiliar names rendered phonetically or transliterated are enclosed in parentheses. Words or names preceded by a question mark and enclosed in parentheses were not clear in the original but have been supplied as appropriate in context. Other unattributed parenthetical notes within the body of an item originate with the source. Times within items are as given by source.

The contents of this publication in no way represent the policies, views or attitudes of the U.S. Government.

PROCUREMENT OF PUBLICATIONS

JPRS publications may be ordered from the National Technical Information Service (NTIS), Springfield, Virginia 22161. In ordering, it is recommended that the JPRS number, title, date and author, if applicable, of publication be cited.

Current JPRS publications are announced in Government Reports Announcements issued semimonthly by the NTIS, and are listed in the Monthly Catalog of U.S. Government Publications issued by the Superintendent of Documents, U.S. Government Printing Office, Washington, D.C. 20402.

Correspondence pertaining to matters other than procurement may be addressed to Joint Publications Research Service, 1000 North Glebe Road, Arlington, Virginia 22201.

Soviet books and journal articles displaying a copyright notice are reproduced and sold by NTIS with permission of the copyright agency of the Soviet Union. Permission for further reproduction must be obtained from copyright owner.

USSR REPORT
MACHINE TOOLS AND METALWORKING EQUIPMENT

CONTENTS

INDUSTRY PLANNING AND ECONOMICS

Machinebuilding: Basis for Retooling (I. Silayev; SOTSIALISTICHESKAYA INDUSTRIYA, 24 Jun 86)...	1
Service Center For Robots Described (B. Khasanov; PRAVDA VOSTOKA, 23 Mar 86).....	7
Common Sense Urged in Acquiring Robots (L.I. Volchkevich; IZOBRETATEL I RATSIONALIZATOR, No 4, Apr 86).....	9
'Askatesh' Engineering Center Created (SOVETSKAYA KIRGIZIYA, 26 Mar 86).....	15
Social, Economic Effectiveness of Flexible Automation Viewed (A. Baranov, A. Viyes; EKONOMICHESKIYE NAUKI, No 4, Apr 86).....	16
New Equipment Reviewed (S. Pravdenko; EKONOMICHESKAYA GAZETA, No 20, May 86).....	21
No Standstill for Machines (I. Simenskiy; NARODNOYE KHOZYAYSTVO BELORUSSII, No 3, Mar 86).....	23
Briefs	
Product Quality	26
Soviet-Bulgarian Joint Ventures	26
NC Lathe Servicing	27

OTHER METALWORKING EQUIPMENT

New Laser Sensor Described
 (NTR: PROBLEMY I RESHENIYA, No 4, 18 Feb-3 Mar 86)..... 28

Briefs

 Hydraulic Die Forging 29
 Press Foundation 29
 Plasma, Machining 29
 New Machine Tools 29

AUTOMATED LINES AND AGGREGATED MACHINING SYSTEMS

Problems of Machinebuilding, Automation
 (A. Kostin; NTR: PROBLEMY I RESHENIYA, No 4,
 18 Feb-3 Mar 86)..... 30

Quality Improvement Measures in Industry
 (V. Neverova; EKONOMICHESKAYA GAZETA, No 19, May 86)..... 33

Turning Robot-Technological Complex Described
 (G.N. Sokolov, et. al.; MEKHAZATSIYA I AVTOMATIZATSIYA
 PROIZVODSTVA, No 3, Mar 86)..... 35

Robotized Technological Complexes Using PR SM40Ts4011 Described
 (Yu. L. Golinets, et. al.; MEKHANIZATSIYA I AVTOMATIZATSIYA
 PROIZVODSTVA, No 3, Mar 86)..... 39

Creation, Use of GPS Lathe Machining Modules Reviewed
 (N.A. Arkhipenko; MEKHANIZATSIYA I AVTOMATIZATSIYA
 PROIZVODSTVA, No 3, Mar 86)..... 42

Briefs

 Robotic Complex 51
 Robotic Systems 51
 Automated Machining Complex 51
 NC Machining Center 51
 Robotic Production Line 52

ROBOTICS

Academy of Sciences Member Reviews Robotics
 (Ye. P. Popov; TEKHNICHESKAYA ESTETIKA, No 1, Jan 86)..... 53

Prices of Robots, Actual Cost in Plants Reviewed
 (EKONOMICHESKAYA GAZETA, No 14, Mar 86)..... 55

Robot Use Viewed
 (NARODNOYE KHOZYAYSTVO BELORUSSII, No 3, Mar 86)..... 57

Briefs

 Robots in Kirovakan 58
 Robot from 'Zhiguli' 58
 Robots Exhibited 58

INDUSTRY PLANNING AND ECONOMICS

MACHINEBUILDING: BASIS FOR RETOOLING

Moscow SOTSIALISTICHESKAYA INDUSTRIYA in Russian 24 Jun 86 pp 1-2

[Article by I. Silayev, deputy chairman, USSR Council of Ministers, chairman, USSR Council of Ministers Bureau for Machine Building: "Machine Building: The Basis for Retooling"]

[Text] The objective conditions of the country's socio-economic development, which were thoroughly analyzed at the 27th CPSU Congress, advance machine building to the front lines in solving a most important task of our day -- formation of the technical basis of acceleration.

It must be said that priority development of machine building has always been at the basis of the party's economic policy. This made it possible for our country to create a powerful scientific and production capability in a historically short period of time and to attain independence from the industrially developed capitalist states. However, life poses new tasks, which, naturally, also require new solutions.

The essence of these tasks is defined in the Basic Directions of the economic and social development of the country for this five-year plan and the period up to the year 2000, which envisions the fundamental retooling of all branches of the economy and the formation of a qualitatively new production capability.

Shifting to a new material and technological agricultural base, for example, will make it possible to introduce industrial technologies widely in this branch; implement the leading achievements of agricultural technology; substantially reduce the time required for field work and reduce crop losses. The scientific and technological revolution opens up extensive opportunities for making profound structural changes in energy, and for the effective technological retooling of metallurgy, transport and other branches of the economy. The task is to embody these potential capabilities in reality. But so far, unfortunately, our machine building is not prepared to solve it completely. Profound and very serious retooling is needed.

Today the most unyielding knot surrounds the problem of the level of equipment being developed. Machine builders have been given an intense task: to more than double the output of highest quality category products by 1990. If it is added to this that the conditions for certification are simultaneously being

tightened up, and that the highest category will now be awarded only to those products which really correspond to or exceed the world standard, then it is necessary to acknowledge openly that for many collectives these goals seem extremely high. But it is necessary to meet them.

The roots of the problem go back to the practice which took shape when developers, beginning to develop new machinery, oriented themselves on similar foreign models. As a result, many types of equipment, both that being series produced and new equipment just being assimilated in production, lag behind the world level. In other words, we today are building in tomorrow's lag. This is impermissible, especially when we are talking about such priority branches as machine tool manufacture, electronics and machine building. The solution is to shift from the worn out principle that "the new must be better than the old" to precise qualitative parameters, which guarantee that products will be developed at the world standard.

What, specifically, is required for this? First it is necessary to overcome the syndrome, which has become rooted in the consciousness of many, of our inability to reach the leading standards. Institutes, design buros and ministries in recent years have invested considerable forces in justifying this postulate, by making reference to the lack of materials and equipment sets; worse operating conditions, etc. It is time to stop wasting energy searching for justifications. The leaders of branches and lead institutes must concentrate their efforts on systematic scientific analysis of world achievements in various technical and economic indices; disclose and substantiate the main tendencies and on this basis assign developers specific objectives.

It is entirely natural that with such an approach the developers of new equipment will no longer be able to match the targets to their capabilities. It will be necessary to change the style of work radically; to raise capabilities to level of the target and, most of all, to strengthen cadres and promote to the leading fields highly qualified specialists, capable of solving present day tasks.

Unfortunately, changes here take place slowly. So far no fundamental change in the approach to investment policy has taken place either. Recent practice, when essentially all the capital investments of the ministry were directed toward developing series production, led to a situation in which today the scientific research institutes and design buros are very poorly equipped with research and testing equipment; do not have experimental plants and are unable to develop laboratory testing equipment for themselves. As a result, some of them are capable of creating only paper, but in no way can they develop modern equipment. Meanwhile, even in this five-year plan, Minselkhovmash [Ministry of Tractor and Agricultural Machine Building], Minzhivmash [Ministry of Machine building for Animal Husbandry and Fodder Production], Mintyazhmash [Ministry of Heavy and Transport Machine Building] and several other ministries in their draft plans have not allocated sufficient funds for the development of experimental bases.

Needless to say, these proposals were not accepted. Only it is not enough to change a figure in a document, even if it is a very important one. It is also

necessary that leaders clearly understand that providing specialists with computer equipment and SAPRs [design automation systems] and establishing powerful experimental bases equipped with modern test benches, which permit rapid and effective testing of design decisions, is the real way to create world level equipment. This will make it possible to reduce sharply the times required for developing new products and to rid ourselves of such a widespread illness as shifting untested designs into series production, which later requires years to complete.

These are the main changes which modern technology for the development of new equipment requires. Their necessity is confirmed by world practice and the experience of our leading collectives, especially that of scientific production associations, where lately success has been achieved in ensuring a steady process of creating advanced, competitive equipment and in organizing its series production.

This experience was carefully analyzed and became one of the cornerstones in the restructuring which is now taking place in machine building. The overwhelming majority of branch scientific research and technological design organizations (approximately 70-80 percent) joined production and scientific production associations. Virtually only the head branch institutes remain independent. Working in close contact with academic science, they must define the main lines of development of their branches; establish specific objectives for the enterprises and associations and the methods of achieving them; and bear full responsibility for correctly assessing the level of production.

Thus, a logical structure of machine building scientific and design forces is taking shape: head institutes, which are now establishing inter-branch scientific and technological complexes, and, finally, the most massive element -- 430 powerful production and 150 scientific-production associations. This is a tremendous capability. It makes it possible to "cover" all the main problems of technological progress and to ensure the necessary scientific and design developments to solve the main tasks assigned the machine builders: to increase 1.5 or two-fold the reliability and productivity of the new equipment and reduce 3-4 fold the time required to develop and assimilate new machinery.

In order to solve these tasks completely it is necessary to restructure the machine building production apparatus. Even today one of the main obstacles to advanced developments is becoming the bottleneck of the production capacities of enterprises -- they are unable to be retooled quickly for new products or to provide the level of precision and manufacturing quality which the innovations require. And, during the years of the five-year plan it is necessary to triple the share of machinery being assimilated for the first time from 4.5 percent to 13 percent of the overall volume of machinery! At the same time it is necessary to increase production volume growth rates almost 1.7-fold.

In the current five-year plan, more capital investments than ever before -- almost twice those of the previous plan -- are being allocated to the development of machine building. However, it is entirely obvious that if these funds are spent as they were before the targets assigned to the branch will not be fulfilled. There is one alternative: in the next few years it is

necessary to restructure machine building production fundamentally; to make it highly mobile, highly productive and of high quality.

Structural advances are planned in the production of Minstankoprom [Ministry of Machine Building] enterprises, which bear the main burden of the technical retooling of machine building. The production of NC machine tools will rise 2.1-fold, and the output of "processing centers" will rise six-fold. Production of rotary and rotary-conveyor lines -- the bases of fundamentally new technology -- will receive widespread development. Overall, the share of advanced equipment will reach 85 percent of the overall volume of Minstankoprom products.

Recently, in-house machine tool manufacturing has been actively developing in machine building branches, oriented mainly on the manufacture of specialized technological equipment. Its amounts will be increased not four-fold, as outlined in the Basic Directions, but seven-fold. Undoubtedly, this will require new ways of organizing its production in the administrative structure of the machine building complex.

Thus, a serious material base for modernization is being laid. Already in the next few years the flow of advanced equipment into machine building enterprises will become much greater. This must be complemented by a reciprocal flow of departing equipment. The size of the equipment park must not be allowed to continue to grow, as was the case until recently. This year a major one-time write-off of old and obsolete machine tools is planned. In the future this measure will become common, and the rates of modernization of the active portion of fixed production capital are planned to rise to 10-12 percent per year.

However, equipping enterprises with advanced equipment is not even the beginning of restructuring, but merely a means and a necessary condition for the formation of modern production. And this begins what I believe is the most difficult problem -- the problem of psychologically tearing down the old ways.

Until now the overwhelming majority of machine building enterprises were structured according to a closed cycle -- with a full complement of billeting, metalworking, assembling and auxiliary shops. This led to a situation in which 63 percent of the enterprises producing cast-iron and steel castings had only 9 percent of its volume. The production cost of a ton of steel casting obtained in these dwarf plants was 800 rubles, while in ordinary shops it was half as much.

These figures conceal overexpenditures of labor and material and energy resources. These old shops do not lend themselves to any sort of mechanization, but a number of ministries stubbornly hold on to them. Moreover, even when new ones are developed they transfer to them the whole train of past shortcomings. A selective check of plans for billeting shops which are now under construction or are planned for this year showed that not a single one provided for flexible production systems, robotics complexes and modules, and that the problems of mechanization of intra-shop deliveries have not been solved. In other words, even those who designed and those who gave

the "go-ahead" to implementing the designs in their concepts went no farther than to solve immediate, "burning" problems in the enterprises.

At first glance this is inexplicable near-sightedness. Everyone knows that while a plan is being developed and while construction and assembly of the equipment is underway today's needs inevitably turn into yesterday's. But there is logic here. And it is explained in the habit of thinking in categories of economy-in-kind. Those who defend the right to such an approach usually refer to the fact that the difficulties of organizing production under conditions of expanding cooperation sharply rise. And this is true. But it is yesterday's truth. Evaluating the activity of enterprises based on their fulfillment of contractual obligations is already now noticeably strengthening delivery discipline. Beginning next year the role of this index will increase still more, and this will improve the conditions for mutual cooperation.

Another important circumstance must also be considered. Parts milling machines, rotary lines, robotics complexes, automated design systems and other types of equipment which today embody the leading level of machine building, can most fully realize their potential capabilities precisely under conditions of specialized production, based on principles of thorough standardization. Today the country is manufacturing 80,000 types of gear wheels and about 20,000 pulleys. Plain bearings and bushings are made by almost all factories. Hydraulic equipment is being produced by more than 30 enterprises and designed by approximately 40 institutes.

The time has come to bring order to this ill-matched economy. Now a decisive policy has been adopted to shift to the modular block principle for designing new machinery. Experience in this field proves its high effectiveness. For example, it was possible to reduce the number of types of tower cranes from 100 to 8, and it enabled a system of 6 types of planetary reducers in various combinations to assemble up to 50 types of wires. It is entirely natural that the manufacture of such equipment will also require an entirely different, qualitatively new type of production. Both the ministries and the enterprise collectives must place its formation at the forefront of their work.

It is clear that accelerating the development of machine building is senseless without new construction materials and components of a high technical level. Most of all solving this task depends on USSR Minchermet [Ministry of Ferrous Metallurgy], Mintsvetmet [Ministry of Nonferrous Metallurgy] and Minkhimprom [Ministry of the Chemical Industry], which must sharply increase the amount of their production. It is necessary that restructuring by parts manufacturers take place in concert with the restructuring in machine building.

This does not mean, of course, that future tasks can even temporarily push ongoing work onto the back burner. Take just the problem of technical retooling. Machine builders justifiably complain about the lack of advanced equipment. And how is that used which does exist? A half strength. NC machine tools and even "processing centers" frequently work on a single shift: there are not enough programs, tools and qualified cadres and utilization has not been thought through. Eliminating these shortcomings means to increase today's output, but at the same time it means to prepare for receiving the equipment which soon will begin to arrive in much greater quantities.

Links in the field of quality and in economizing metal and fuel and labor resources are no less clear. There are many reserves in these areas.

Measures aimed at improving the economic mechanism facilitate more complete utilization of the capability of Soviet machine building. The chemical and petroleum machine building and instrument making branches, as well as a number of major associations in other branches, are now preparing to shift to self-financing principles (according to the example of VAZ [possibly Venyukovskiy Fittings Plant] and the Sumy Machine Building Scientific Production Association imeni Frunze). A law on the socialist enterprise (association) and a number of other important documents are being developed, which should already now free the initiative of the collectives and increase their interest in performing highly effective work.

The resolutions of the June CPSU Central Committee plenum and the USSR Supreme Soviet session required that machine builders still further accelerate the rates of scientific and technological progress, most of all in its priority, highly-effective areas. By comparison with previously planned goals, more intense targets have been set for raising the technical level of machinery and tools and expanding the scale of electronics use, and the modernization rates of branch production apparatuses have been increased.

It must be acknowledged frankly that great and difficult work lies ahead. But, as was emphasized in the Political Report of the CPSU Central Committee to the 27th Party Congress, we are now "at a sharp turning point in the life of the country and of the modern world as a whole." And turning points, as we know, do not take place without difficulties, and without the need to mobilize all forces and find the courage to reject that which is obsolete; comprehend new tendencies and restructure our lives in accordance with them. And, of course, this refers most of all to those who have found themselves on the front lines; in this case the machine builders. To a decisive degree, their work will determine the rates of scientific and technological progress, economic intensification, and, in the final analysis, realization of the grand program for socio-economic acceleration adopted by the congress.

9069

CSO: 1823/227

INDUSTRY PLANNING AND ECONOMICS

SERVICE CENTER FOR ROBOTS DESCRIBED

Tashkent PRAVDA VOSTOKA in Russian 23 Mar 86 p 3

[Article by B. Khasanov, UzTAG correspondent: "Polyclinic for Robots"]

[Text] "It is impossible to achieve cardinal changes on the basis of former material-equipment. We see a way out in extensive modernization of the national economy on the basis of the latest achievements of sciences and technology..." (From the political report to the 27th party congress).

A center for servicing robots and NC machine tools was created in Tashkent. Its "sphere of influence" are the industrial enterprises of Central Asia and Kazakhstan.

Electronics specialists help start up adjustments wherever robotized complexes are introduced, do guaranteed repairs and prepare control software for the new equipment. They can also restore worn equipment.

"Our organization is an original "response" of the USSR Minstankoprom [Ministry of Machine Tool and Tool Industry] to the very rapid increase in the number of robots and to NC equipment generally", stated Igor Nikolayevich Bublik, director of the center. "Plants and factories receive more and more such equipment. Only skilled specialists can place the equipment in operating condition and insure high productivity. It is inefficient and expensive to maintain them at each individual plant. That is why our center was created. The "Polyclinic" for robots is equipped with special equipment. Our specialists study new systems of robot equipment directly at the manufacturing plants.

"The basic directions of the economic and social development of the country, approved by the 27th party congress, speak of the necessity of the wide introduction of flexible readjustable productions, machines and equipment with built-in microprocessors, robot equipment, rotary and rotor-conveyor complexes. How, in your opinion, do problems originate in the enterprises of the republic in this connection?"

"One of the most important problems is to select the correct strategy and tactics for introducing robot equipment from the very beginning. Some enterprises acquire equipment not always taking into account the specific features of the given production. For example, in the "Uzbekhlopkomash" Association NC machine

tools of about ten various systems are concentrated. Even an excellent specialist cannot service this armada at the necessary level. What is the result? The enterprise must have three shifts of from 3 to 4 skilled people so equipment does not stand idle. It would be much more advantageous to acquire one system of machine tools."

"We read in the press that to have a real effect, the introduction of robots must be accompanied by a general increase in production standards..."

"Entirely true. It is time to change in principle the attitude toward new equipment. At some plants in Namangan, say, NC machine tools and robotized complexes are installed... in dirty shops, in cast iron dust and among chips. Such so-called electronics people handle the punched tape with greasy hands and then are surprised when the machine tool breaks or produces scrap. The "Tekhnolog," "Tashtekstilماش" Scientific Research Associations and other advanced enterprises can serve as examples of the proper approach to new equipment.

"What are the first problems of your collective?"

"First of all, to develop to scales required by reality. So far, we encounter great difficulties. Requests received from enterprises exceed our capacity 1.5-fold. Knowing how costly idle time of robot equipment is, we try to help everybody."

"To do it with your possibilities is, obviously, not simple. Somehow, micro-processors, industrial robots, the most complex electronics and...a damp collar, several small rooms seems incongruous."

"Yes, the contrast is noticeable. We are awaiting active help, in particular, from the Tashgorispolkom whom we asked for a larger room. In this five-year plan period, we will start erecting our own building. But even now we have to do something not only for our interests, but also for tens of enterprises."

Now new NC machine tools are being manufactured at the "Tekhnolog" NPO, at the Tashkent "Tashtekstilماش" Electronic Equipment Plant, and a robotized complex is being used at the Tashkent Motor Plant. The creation of mobile diagnostic laboratories are primarily promising prospects for the very near future. Then it will be unnecessary to carry units and parts to the center and many faults can be corrected on location and some of them eliminated immediately. The center could also undertake to train cadres to work on NC machine tools and robot complexes. Exhibitions of the latest systems, exchanges of experience, and seminars for operating and technologists are also necessary.

The latest equipment must operate with a full yield. For this, as was mentioned at the 27th party congress, it is necessary to change, in principle, the attitude toward it, to change not only production, but also the psychology of controlling scientific technological progress.

2291
CSO: 1823/206

INDUSTRY PLANNING AND ECONOMICS

COMMON SENSE URGED IN ACQUIRING ROBOTS

Moscow IZOBRETATEL I RATSIONALIZATOR in Russian No 4, Apr 86, pp 2-3

[Article by L. I. Volchkevich, doctor of technical sciences, chairman of the Committee of the All-Union Scientific-Technical Society for Automation and Mechanization of Production Processes, professor, department head of the Moscow Advanced Technical Academy im. Bauman; passages in slant lines printed in boldface]

[Text] /In his polemical remarks, the author admits that there is no alternative to robots and flexible automated systems in the future, but calls for an adoption of these fruits of the scientific revolution with a view to the costs. The author strongly criticizes showmanship in carrying out the technical policy, which is very costly to the nation's economy./

/"Extensively adopt flexible adjustable manufacturing processes...robot-technical, rotary and rotary-conveyor belt complexes. Convert to delivery of complete technological systems and machine complexes."--From the Basic Outlines of Economic and Social Development of the USSR for 1986-1990 and the Term Up to the Year 2000./

Our expectations of the conditions and components of the work process are rapidly changing. Low-qualification, monotonous and heavy manual labor is becoming unprestigious, unattractive and, in the near future, will also become socially unacceptable. Thus, the conversion of the major sectors of the economy to a highly-mechanized and integrated-automated production is a necessary and inevitable process.

What concerns us is another matter. Shall we be able to automate the manufacturing process in compliance with the economic demands, or will we solve the social problems with no heed to the costs, at any price, and find ourselves, albeit technologically-reoutfitted, also--impoverished?

It seems paradoxical, but the abrupt and revolutionary expansion of the technical arsenal of automation in machine construction brings not an acceleration in the rate of increase in labor productivity, reduction in numbers of those occupied with manual labor, and other anticipated benefits, but in fact a substantial lowering of these.

The paradox is only apparent. We are simply reaping the fruits of the many twists and turns in the technical policy of automation, which substitutes hectic campaigning for reasonable, well-thought-out principles.

The indisputable promise and progressiveness of the new technology, particularly electronics and computer technology, have convinced many of the absolute effectiveness of their use in every situation. Thus, scientific-technical progress has come to be gaged and evaluated not by the improvement in the basic technical-economic indexes of production, but by the number of industrial robots, computers and flexible modules. The means are replacing the ends. Instead of always working toward the end results--improved quality and quantity of manufactures, lower net costs and improved returns--we sometimes deceive ourselves. First we try to plan the production and adoption of the maximum number of "fashionable" technologies and systems, then devote all our energy to fulfilling these wishful plans, or better, to "hammer out" a profitable balance sheet for them. Often we ignore both the actual needs of the industries, e.g., for industrial robots, as well as their technical level: the question of actual effectiveness of application is far from secondary. All failures and blunders are blamed on the factory workers, as though they refuse to embrace the robot and are indifferent to progress. On the other hand, certain of the ministerial staff acquire the reputation of energetic and unwavering champions of all that is new and progressive, and enjoy a long and comfortable career at the forefront of scientific-technical progress.

Such policy of arbitrary, compulsory administration in matters of specific industrial application of the new technology is fundamentally flawed. The most progressive new technology, adopted in the wrong place, at the wrong time, and in the wrong way, turns into its opposite. It simply results in unjustifiable expenses, without yielding the expected technical, economic or social impact. Arbitrary, premature and compulsory acquisition of inadequately developed design strategies is especially fatal.

Too often in recent time genuine scientific-technical progress has been replaced by scientific-technical showmanship. The most melancholy fact is that showmanship, as a rule, feeds off of the latest and most progressive scientific-technical trends. And we need not look far for examples.

Fifteen years ago the first automated production management systems were built--the ASUP. They were quickly hailed as a sort of panacea for all the ills and troubles of manufacturing. At once, the immediate introduction of ASUP was dictated to the enterprises "from above", the ASUP was praised and sworn by, and new technology funds were approved only for the ASUP. In response, many enterprises and associations hastened to acquire computer technology at any price, to "squeeze" staff and funds out of their budgets, and to organize the floor space. What would be the result and what the cost almost no one wondered, neither at the "top" or at the "bottom"--they would figure it out later, once the ASUP was in hand! But later they often did not know what to do with this ASUP.

Of those projects, nothing remains but bitterness and embarrassment. The wholesale campaign of "ASUP-ization" of production was simply premature. It was not supported by a conscious realization of the aims and goals, the priorities, and the realistic possibilities. The arsenal of hardware and software was not adequately developed. And, what is most important, many enterprises were simply not prepared, owing to their backward technology and equipment, and a low level of management and industrial culture. After all, the gulf between reality and appearance is especially large at the poor performance enterprises. What could the adoption of ASUP provide under these circumstances? Only a switch from the usual eyewash to electronic eyewash. The result was a twofold loss: the millions of rubles simply wasted and the delay in development of this really promising trend after the initial delight was replaced by disappointment.

Regrettably, these negative events are recurring here and there--this time it involves industrial robots (PR). The progressiveness and promise of PR are indubitable, but even so all robots are not the same. All the industrially developed countries are energetically and painstakingly working out the designs, looking for the most promising applications and little by little increasing production in dependence on the actual results. Today there are no more than 3000 functional PR in the USA, and 10,000 in Japan. But we have devoted all our energy to a hasty organization of wholesale PR production, even to the extent of a planned system of allocation of PR to the enterprises "from the top." In the past five year period alone we have built almost 50,000 PR, the majority of them transport and loading PR. This in itself, beyond the achieved social-economic results, is claimed as an immense achievement; moreover, the original plans have been met by 130 percent--an unprecedented phenomenon in our day. But the actual results are equally surprising and unprecedented. It turns out that half (!) of the industrial robots (which is around 13,000 robots costing hundreds of millions of rubles) in 1981-1983 simply did not make it to factory utilization. Clearly, they are not all that essential. But what is the actual effectiveness of those that were adopted? I know of only one example of a serious scale analysis. Six hundred robots costing 10 million rubles provided an annual economic impact of only 18,000 rubles. Each robot on the average replaced 1/14 of a worker per shift. And there are other examples. The hot forging sector of the Zhdanov Heavy Machine Plant decided to adopt two Tsiklon-35 robots. But it turned out that the robots cannot operate with the stock normally used in manual loading. Additional equipment and an additional operation were introduced to make the stock "fit the robot." After this, it was found that the robots were also inoperable at the temperature prevailing in the sector. Cooling was installed, but now it was found "unexpectedly" that the presses were obsolete and required overhauling. The presses were overhauled and finally matched to the robots. And now it turned out that the robots work so slow that the productivity of the sector has actually dropped. After this, one robot was taken away, the other is used for accounting purposes.

A similar story occurred at the Tashkent Tractor Plant, where a technological module of two presses and an industrial robot was built. While the work cycle was 3-5 seconds for manual loading, it has now become 45 seconds. The productivity has dropped tenfold.

Why are we rushing to turn out thousands and thousands of robots of certain expensive and unwieldy, slow and unreliable designs, knowing in advance that a sizable portion of them will end up in the storeroom or be sent directly to the scrap heap?

The whole world has now turned to technological robot construction, where it is possible to obtain a maximum impact by improving the quality of production and the equipment productivity. But we remain oriented, through inertia, toward primarily loading and transport robots, which are the least promising and effective. Simply because with these it is easier to compose a favorable balance sheet? For example, the Zaporog Automotive Plant has built a robot sector from multifunctional semiautomatic building-block machines. There is no improvement in manufacturing quality, since the robots simply insert and remove stock. Nor is there an improvement in productivity, since both manual and robotic loading are dependent on the machining time. But strange as it may seem, neither has there been a reduction in the labor intensity of the attendance or a savings in manpower, for while previously a worker would take each piece of stock from a bin and insert it directly into a holder, now they continue to take each piece and insert it into a magazine, from which the robot takes it and inserts it into the holder. Moreover, the work has become more difficult: the robots clutter the work space. Adjustment of the machines, changing and set-up of tools, continue to be done by man. But now it is also necessary to service the robots. It is now clear to virtually everyone that robotization is undergoing a severe crisis, which appears in the obvious discrepancy between the expenditure of manpower and assets, on the one hand, and the actual output of the robots on the other. The real achievements drown in a sea of "robot window-dressing" and the efforts of the truly motivated are not appreciated. But there is no change in the technical policy of robotization and the applause continues to thunder.

However, all the losses and detriments resulting from unthinking robotization are nothing in comparison to the possible loss from creating flexible automated manufacturing systems (GPS), unless there is a change in the trend of the technical policy. Once again, there are hasty plans for a rapid increase in the rate of production and adoption, and once again this in itself is advertised as a grand achievement.

But it may be noticed that the greater the enthusiasm for GPS in general or specific models in particular, the harder it is to find even a mention of the price, or the effect on net production costs or return on investment; and the more obvious the tendency to get by with a couple of publicity figures concerning increase in labor productivity, reduction of work force and shortening of the production cycle.

But these are extremely intermediate and secondary indicators, which prove nothing by themselves. Thus, an increased turnout of products by certain workers (which is what is meant by the term "increase in labor productivity") may be accompanied by impairment of all the basic technical-economic indexes of production, including direct economic losses or even an increase in the overall work force on the shop or sector level.

At present, the overwhelming majority of GPS have been built for cutting operations; moreover, for the machining of body parts. A typical GPS is composed of 5-6 "machining center" type NC lathes, an automated materials handling section, a transport and distribution system, and a two-level computer-based control system. The typical cost is 5-6 million rubles. The typical comparative indexes as opposed to nonautomated sectors of equivalent technological capabilities and flexibility are as follows: increased costs adjusted per unit of lathe equipment 25-30 fold, increased productivity of one lathe 2-2.5 fold, reduction in labor force on the payroll 2-2.5 fold; according to the publicity indicators, it is all up to date: the labor productivity is raised 4-6 fold, 10-15 workers are replaced, the production cycle for a particular assortment of parts is shortened by 40-60 percent. But if we consider the change in the most critical technical-economic indicators, the situation is somewhat different. The return on investment is 12-15 times worse. Instead of freeing up workers and reducing the shortage of manpower, there is a transfer "to a different pocket", with a worsening of this shortage on the level of the national economy. In fact, production assets costing 5-6 million rubles represent an additional economic outlay of provisionally 1000 man-years, while no more than 120-150 man-years are made available during a 10 year term of operation. The additional investment is not recovered, for each year 700,000-800,000 rubles of operating costs are added (the rising depreciation deductions, repair and servicing expenses are not offset by the savings in wages).

Finally, the labor productivity of society, taking into account present and past labor (in terms of K. Marx), does not increase, but decreases 3-3.5 fold!

True, this is tentative, since there are no accounting procedures, but the end results are indisputable.

Of course, this is quite natural. A fundamentally new scientific-technical trend is being formed, for which there is no future alternative. But given the present conditions, and the existing technical-economic level, should we hastily jump from several dozen GPS, built during the current five year period, to several thousand GPS, which are scheduled for the future? Their provisional cost is 10-15 billion rubles. Can we take such a risk?

After all, unless we can radically improve the technical-economic indicators of the GPS in the shortest time (and it is the inventors and rationalizers who have the last word here) and close the gap between increasing cost and productivity (which is incredibly difficult), a significant number of these assets may become losses.

And such losses will be downright inevitable unless we revise the economic mechanism at all levels, from the shop to the ministry, and the urge to create an appearance of well-being at any price will prove stronger than the interest in genuine scientific-technical progress.

It will also be necessary to change many of the traditional procedures for implementing the technical policy of automation. Only under such circumstances will the labor productivity increases outlined by the resolutions of the 27th Congress of the CPSU become possible and tangible.

COPYRIGHT: "Izobretatel i ratsionalizator", 1986

12717

CSO: 1823/224

INDUSTRY PLANNING AND ECONOMICS

'ASKATESH' ENGINEERING CENTER CREATED

Frunze SOVETSKAYA KIRGIZIYA in Russian 26 Mar 86 p 2

[Unsigned article: "Askatesh--Engineering Center"]

[Text] (KirTAG)--"Askatesh", the first engineering center of general and mining machine building in the republic, was created at the facilities of the Kirghiz SSR Academy of Sciences' Institute of Automation. Its primary aim is the intensification of basic and applied research and acceleration of the development, creation and introduction into production of new machinery and technologies. At the same time, the restructuring of academic science in light of the decisions of the 27th CPSU congress has been initiated.

The center combined the institute's existing department of mining machine building, the experimental design bureau for the production of machinery prototypes, the compaction laboratory, Frunze Polytechnical Institute's Department of Flexible Automated Production Lines and the standing expedition of mining machinery science at the Sary-Tash test grounds in Osh Oblast.

The organization of this center were planned over the past several years. All of the aforementioned subdivisions of various departments continually worked in close contact. The center's official recognition creates additional conditions for stimulating developments and a reduction in the time lag between basic research, applied science and the design and introduction of innovations into production.

The center's production facilities are equipped with special-purpose equipment; flexible automated lines, machine tools with numerical control, robots and computer equipment have been installed there. Highly productive press complexes, general-purpose "Machining center" type machines and heavy-duty manipulators for mechanizing labor-intensive processes in construction and in the reconstruction of existing enterprises will be created at the engineering center. The engineering center will use automated design systems and up-to-date means of ergonomically evaluating the machinery being created.

Scientists, designers, technologists, new machinery testers and highly skilled workers are united into a single, creative collective. It is planned to complete the construction of an experimental design bureau and the adjustment of equipment, resolve all organizational and technical questions and begin the production of the first prototypes of advanced equipment in the first year of the five-year plan period.

INDUSTRY PLANNING AND ECONOMICS

SOCIAL, ECONOMIC EFFECTIVENESS OF FLEXIBLE AUTOMATION VIEWED

Moscow EKONOMICHESKIYE NAUKI in Russian No 4, Apr 86 pp 36-42

[Excerpt of article by A. Baranov and A. Viyes, candidates of economic sciences]

[Excerpts] Implementation of the strategy for accelerated socioeconomic development of the nation, as pointed out by comrade M. S. Gorbachev in the Policy Report of the CPSU Central Committee to the 27th Party Congress, requires a profound reorganization of the economy on the basis of the latest achievements of science and technology. The greatest economic and social impact will come from progressive technological processes and flexible manufacturing with swift adjustment to turn out new products.

One of the requirements of the CPSU program for the near future is to carry out a comprehensive mechanization in all production and nonproduction sectors and to achieve major progress in the automation of production by a transition to automated workshops and enterprises and computer-aided design and control systems. Even today, the foundations are being laid for transformation of automation into a universal feature of production.

In the opinion of the experts, there exist at least three types of flexible manufacturing at present: mass production with periodic reorganization for different products of the same kind; series production with relatively stable products, where the need for frequent adjustments is solely due to the inadequate manufacturing scale; and finally, production with an undetermined, constantly-changing assortment.¹

The economic literature has already pointed out that the time has arrived for development of specialized interindustry production, e.g., production

¹Cf. Volchkevich, L., "Are GAP Always Effective?", Ekonomicheskaya Gazeta, No 40, 1985, p. 15.

"tied to" major territorial machine construction components.⁶ In particular, it is mentioned that "technical reorganization of the machine construction base proper can only be achieved through an interindustry, programmed, national approach, which does not fit into the confines of the existing system of planning."⁷ A similar approach, evidently, should also underlie the planning of the development and introduction of GPS (flexible manufacturing systems).⁸

The creation of interindustry, regional and international economic production systems gives rise to a new and fundamentally different form of primary industrial organization, alongside the existing forms (production association or enterprise): the interindustry regional complex.

The creation of interindustry, regional and international economic production systems on the basis of flexible automation will create optimal conditions for the concentration and specialization of production, implementation of a consistent scientific-technical and investment policy, and (ultimately) improved labor productivity--lowering of the socially-necessary labor costs per product. This will enable a better achievement of the goals of the CPSU: superior international level of labor productivity, product quality, and substantially increased level of socialization of labor and production.

Along with the generalized indexes of effectiveness of utilization of GPS, their direct economic impact may be expressed, first, by the manufacture of certain types of product of high quality, which at the same time satisfy the economic requirements of optimal costs and observance of the time schedule, quantity and assortment specifications; second, by the freeing up of socially-necessary resources: labor, monetary, material, natural, informational.⁹

The savings in resources by using GPS at any level of the economic system can be determined by:

$$\Xi_{pk} = \sum_{i=1}^n (3_{ki}^1 - 3_{ki}^2) A_i, \quad (1)$$

⁶Cf. Nauchno-tekhnicheskaya revolyutsiya i sotsialisticheskaya sistema khozyaystva [The Scientific-Technical Revolution and the Socialist Economic System], ed. by A. I. Anchishkin and Yu. S. Shirayev, M., 1983, p. 36.

⁷Ibid.

⁸In the opinion of the experts, individual U.S. companies in time "will start renting out their flexible automated complexes to other manufacturers, just as the companies sold machine time of their computer centers in the 1970s" (Kochetkov, G. B., "Flexible Manufacturing and Management," SShA: ekonomika, politika, ideologiya, No 1, 1985, p. 86).

⁹In speaking of labor economy we should emphasize that the absolute reduction in number of workers occurs primarily during the initial stages of GAP introduction; after this, it is primarily a question of the relative savings per unit of production.

where \mathfrak{S}_{pk} is the annual savings of the k-th type of resource; $3_{K_i}^1, 3_{K_i}^2$ are the costs of the k-th type of resource during production of an i-th product in cost or physical terms, respectively, before and after introduction of the GPS; A_i is the manufacturing program of the i-th product; n is the assortment of manufactured products.

The direct economic impact from use of GPS at an enterprise and in the sector \mathfrak{S}_2 can be determined as:

$$\mathfrak{S}_2 = (3_1 - 3_2) A_2, \quad (2)$$

where $3_1, 3_2$ are the adjusted costs per unit of product when using the primary equipment and the GPS, respectively; A_2 is the annual volume of manufactured products using GPS in physical terms.

We should also consider the secondary impact on the GPS-using enterprise during the start-up of production. It has already been mentioned that the placement in service of the new equipment required for GAP involves, as a rule, high production costs per unit of product, due to the considerable volume of fixed expenses, distributed over the small (initial) volume of production. The relation between the specific costs and the product serial number is known to be an exponential function¹⁰, where y is the cost of manufacturing the x-th unit of a new product; a is the cost of production of the first unit of the product; x is the serial number of the product, counting from the start-up; θ is the slope of the curve, characterizing the rate of relative decrease in economic indicators as industrial mastery of the product is approached. In our example hereafter we assume an index 1 for nonautomated and 2 for automated production.

The additional impact (savings from reduced net costs per unit of product) from the introduction of GPS $\mathfrak{S}\Delta$ comes from the fact that the start-up process of GAP has a faster pace than nonautomated production ($b_2 > b_1$), being computed as the definite integral:

$$\mathfrak{S}\Delta = a \int_{x_0}^{x_k} (x^{-b_1} - x^{-b_2}) dx,$$

where x_0, x_k is the serial number of the product beginning and ending the start-up phase.

¹⁰For more details on the specific production indicators during the start-up period cf. Aniskin, Yu. P., Moiseyeva, N. K., Proskuryakov, A. V., Novaya tekhnika: povysheniye effektivnosti sozdaniya i osvoyeniya [New Technology: Increased Effectiveness of Development and Start-Up], M., 1984, p. 109-190.

The generalized indicators of the direct overall economic impact from the use of GPS at an enterprise and in a sector are the total amount of profit (assuming no influence of the various retail price rises) and the reduction in net costs of product (assuming no change in the specialization of the enterprise before and after introduction of GPS). Partial indicators of the operating effectiveness of an enterprise adopting GPS are, e.g., the labor productivity, the capital productivity, the capital intensiveness, the specific consumption of materials, and the costs per ruble of merchandise.

Calculations with the above formula more or less entail a determination of the relative economic effectiveness of operation of GPS as compared to other production systems. A necessary condition for the use of these formulas is the manufacture of uniform products before and after adoption of GPS.

The economic literature expresses the view that it is impossible to use a method of comparison of manufacturing versions of uniform products by means of manufacturing processes with different degree of automation, as the substance and conditions of the work in these versions are fundamentally different.¹¹ Granting the necessity of considering the differences in the working conditions of automated and nonautomated production, nevertheless we do not regard this requirement as sufficient justification for giving up all determination of the relative economic effectiveness of use of GPS.

The relative economic effectiveness of GPS should be determined in terms of: 1) the nonautomated production; 2) the use of individual robots, manipulators and automatons in the production; 3) analogous GPS. In analyzing given types of relative economic effectiveness, the formula determining the annual economic impact from the production and use of GPS should be modified according to the level of automation of the basic object and the level for which the evaluation is being done.

In view of all the above factors, the economic feasibility of adoption of GPS on the national level may be determined by a formula estimating the economic effectiveness of the new technology, supplemented by indicators reflecting the degree of satisfaction of the nationwide demand for the product manufactured by the GPS. The annual economic impact from introduction of GPS (Θ) will be:

$$\Theta = \left[\sum_{j=1}^m \sum_{i=1}^n (3_{ji}^1 + 3_{ji}^2) \cdot \frac{B_{n_j}}{B_{ji}^1} \cdot \frac{P_{ij} + E_n}{P_2 + E_n} \right] +$$

$$+ \frac{\sum_{i=1}^n [(C_i^1 - C_i^2) + E_n(K_i^1 - K_i^2)]}{P_2 + E_n} - 3^2 \alpha [3_n + \Theta_a + \Theta_c + \Pi] A_2 p_2, \quad (6)$$

where $\alpha = \frac{B_1^1}{B_{n_1}} \cdot \frac{B_2^1}{B_{n_2}} \dots \frac{B_n^1}{B_{n_n}}$

¹¹ Cf. Kulbovskaya, N., "Social-Economic Effectiveness of Technical Re-Equipment of Work", Voprosy ekonomiki, No 3, 1984, p. 45.

3_{ji}^1 is the adjusted costs for the j-th type of basic equipment manufacturing the i-th product; m is the number of types of basic equipment carrying out all kinds of work required by the technology of manufacture of the i-th product, implemented by a single GPS; $3_{B_{ji}}^1$ is the cost of transportation, warehouse, tooling and managerial work done in the technology of manufacture of the i-th product, adjusted to the annual production volume, corresponding to the nationwide demand (B_{Π_i}) in physical terms; B_{ji} is the annual production volume of the i-th product by the j-th equipment in physical terms (productivity of the j-th equipment); B_i^2 is the annual production volume of the i-th product by GPS in physical terms (GPS productivity); P_{ij}, P_2 are the percentage of charges for total rehabilitation of the j-th type of equipment and GPS, respectively; E_H is the standard coefficient of effectiveness of capital investments; C_i^1, C_i^2 are the net costs of production of a unit of i-th product with the basic equipment and the GPS, respectively; K_i^1, K_i^2 are the annual incidental capital investments needed to manufacture the i-th product in the volume B_{Π_i} using the basic equipment and the GPS, respectively; 3^2 are the adjusted costs of the GPS; α is a factor for the degree of satisfaction of the nationwide demand for manufacture of the i-th product; 3_H are expenses occurring in nonproduction sectors, involving preparation of special staff for introduction and attendance of the GPS; \mathfrak{Z}_R is the savings due to the use of products manufactured by GPS in event of a substantial quality improvement; \mathfrak{Z}_c is the social impact from adoption of GPS (in terms of costs); Π is the additional volume of material welfare and services obtained by utilizing the resources (workers) freed up by adoption of GPS; A_2 is the GPS production volume; p_2 is the probability of full utilization of all benefits of GPS.

Besides the traditional cost items (primary and raw materials, wages, fuel, expenses of the workshop and the entire industry), the net costs of products manufactured by GPS also include the costs of set-up of the GPS equipment and tools, preparation of the control programs, as well as depreciations and expenses for repairs and maintenance of the ASIO (automated system for information support), ATSS (no expansion given), computer and other hardware of the ASU GPS (automated control of the flexible manufacturing system). The capital investments and unit-time costs of the GPS include the costs of the SAPR (computer aided design system), pre-production costs, capital investments on equipment, unit-time costs for adjustment to a new product, capital investments on the ASIO and ATSS, as well as the computer and hardware of the ASU, and the unit-time costs for accessories, tools and working capital.

COPYRIGHT: Izdatelstvo "Vysshaya shkola", "Ekonomicheskije nauki", 1986

12717

CSO: 1823/220

INDUSTRY PLANNING AND ECONOMICS

NEW EQUIPMENT REVIEWED

Moscow EKONOMICHESKAYA GAZETA in Russian No 20, May 86 p 18

[Article by S. Pravdenko: "Look at the Mirror of the Future"]

[Text] The achievements of the Kiev Machine Tool Building Production Association appeared obvious to everybody and, therefore, at first glance, the words of V. Kalchenko, general director, sounded unexpected: "We delayed unjustifiably the renovation of the output, the design of a new series of machine tools and the creation of NC machine tools. Apparently, a psychological factor played a certain role in this -- our output is in stable demand by customers at home and abroad. So we became content.

It can be said that the last two years in the association passed under index "N." [Renovation]. During that time, for example, a number of technological innovations were introduced. In particular, electrical slag casting, friction welding, and electro-hydraulic cleaning of castings. Products manufactured by the association were also renovated.

One of the innovations is a model KA-143 automatic machining center. It manufactures cross beams for the Cardan shafts for the Kherson Plant. Many solutions applied in the machine tool exceed world standards.

Still another innovation of the Kiev people is the KA-379, an automatic complex for machining diesel pistons. The intermediate product of the piston is clamped in a self-centering chuck, passes through all turning, drilling and milling operations and comes out the finished product.

"After the 27th party congress," related Valentin Nikolayevich, "we saw ourselves in the mirror of the future. We realized that we should not rest on our laurels but tighten up and accelerate the development of new machines that exceed the best specimens abroad and sharply reduce assimilation time for producing new products."

"How to do that, what reserves to mobilize?" The activation of the human factor is rightly considered the main reserve in the association. It is not by chance that an improvement in labor and living conditions for the association's workers is accomplished by a significant increase in labor activity.

A year ago, the number of communists in the association was over a thousand (now almost every sixth person in the enterprise is a party member). The party committee of the machine tool builders received the rights of a raykom and the influence of the party in the collective increased. Communists' reports were more widely given to the collective. At the same time, stricter demands were made of the general director and of each worker.

The initiative of P. Matvichuk's milling brigade "Each brigade--highest productivity of labor and product quality, each member of the brigade -- exemplary work position," was disseminated widely in the entire republic. During the past five-year plan period, labor productivity of the brigade increased by 67 percent. The initiative was facilitated greatly by the fact that in the association there are no shops, sections, brigades that do not fulfill their tasks and overfulfill the five-year plan for increasing the productivity of labor. Nor is the advanced collective lessening its efforts.

The association's collective has taken the course on creating new in principle machines which exceed products of leading foreign firms in technical standards. It was decided to reduce sharply the times for creating and placing new machine tools in series production. This involves the output of a new series of special machine tool with expanded technological possibilities, robots and manipulators. They will be capable of being easily built into automatic lines for various purposes, easily readjustable and will operate in the unmanned technology mode.

A good engineering foundation was laid for achieving the outlined plan. It involves the reequipping of the association and wide cooperation with academic and industrial institutes. According to specialists, new Kiev machine tools will make it possible for users to save 60 million rubles in the five-year plan period due to freeing men and areas, and will save metal and electrical power.

The output of the new type of equipment was mastered by the workers of the association. NC machining centers manufactured here also do drilling and milling operations along with turning. Thousands of machine tool operators will be freed as a result of the introduction of these machine tools.

2291
CSO: 1823/209

INDUSTRY PLANNING AND ECONOMICS

NO STANDSTILL FOR MACHINES

Minsk NARODNOYE KHOZYAYSTVO BELORUSSII in Russian No 3, Mar 86 pp 21-22

[Article by I. Simenskiy, sector chief, Belorussian Branch of the Labor Research Institute, candidate of economic sciences, under the rubric "High Labor Productivity at Each Work Station"]

[Text] At many enterprises NC machines comprise 20-25 percent of the total machine tool fleet. At the same time, the effectiveness of their utilization is clearly inadequate. There are great standstills and the loading factor is low. One of the reasons is the poor level of technical-organizational preparation of the introduction of progressive equipment.

Preparation for adoption of NC machines includes selection of the required model, determination of the nomenclature of the parts to be machined, training of the operators and set-up workers, construction or acquisition of the auxiliaries, cutter tools and gauges, and analysis of the technological processes and control programs. It is also highly important to work out a rational system of payment and incentives for the specialists involved in the operation and servicing of high-performance equipment.

Let us take the operators. At the majority of enterprises they are paid according to a piece-work/premium system, which has certain drawbacks. In fact, the operator's output is determined by the nominal length of the control program cycle--a factor independent of himself. The operator can influence the time spent on insertion and removal of the work, attendance of the work station and preparatory-concluding jobs. But there is no incentive for this in the established payment system. However, for operators working at universal lathes, the output norm is usually set on the basis of experimental-statistical norms and their earnings will be higher. Thus, the operators are placed in unequal situations.

In this connection it is interesting to mention the experience of the Minsk Machine Tool Plant im. The October Revolution, the Krasnodar Machine Tool Plant, the Leningrad "Red Guard" Production Association, which are using a time-based premium system of remuneration of NC lathe operators, whereby the earnings depend directly on the quantity and quality of their work. Essen-

tially, the system is geared to a collective (team) form of labor organization. Teams of 5-6 are formed from the lathe operators. The teams are headed by the most qualified operators, who also perform the set-up chores. The average number of a team is equal to the number of jobs being performed. The wage of the workers is composed of the wage scales (base rate), a premium for fulfillment of the assigned production norm, onetime premiums and other payments.

The base rate includes the wage scale for the time actually worked and a bonus for professional skill, graded according to the number of machines attended and the models thereof. Thus, an operator working at one lathe and able to operate one NC system is awarded 5-10 percent of the wage scale, an operator working at two machines with different systems or at one machining center is given 15-20 percent, an operator working at three machines with one or two NC systems or at two machining centers with one system is given 25-30 percent, and an operator working at three machines with three different systems or at two machining centers with two different systems is given 35-40 percent.

The wage scale (T_{st}) with bonuses for professional skill (D_{pM}) is in fact the base rate from which the earnings are computed. This is equal to:

$$Z_b = T_{st} \left(1 + \frac{D_{pM}}{100} \right), \text{ rubles.}$$

The assigned norm of the team is calculated in norm-hours:

$$Z_n = F_m - K_{p.p.} - T_b - T_s - K_{pr} T_{remn},$$

where F_m is the monthly scheduled work time fund; $K_{p.p.}$ is a factor for the standstill time of the machine for scheduled maintenance; T_b is the work time lost for sickness; T_s is the holiday time; K_{pr} is a factor for the operator's idle time due to repair work; T_{remn} is the machine standstill time for scheduled maintenance; n is the number of machines assigned to the team.

The premium for fulfillment of the monthly assigned production norm is added to the base rate in the amount of 20-30 percent. For overfulfillment, there is a raise of 1-2 percent for each percentage of overfulfillment of the plan. The maximum size of the premium is 40 percent. Conversely, for nonfulfillment of the monthly assignment the remuneration is decreased by 2-4 percent for each percentage of underfulfillment. No premium is paid if the assignment is fulfilled by less than 85-90 percent.

For manufacture of high-quality products under conditions of no-defect work, the members of the team are awarded a monthly premium of 10 percent of the base rate. Team members who have violated the conditions of no-defect work during the particular month have their premium reduced by 25 percent for one instance, 50 percent for two, and 75 percent for three.

The allocation of the collective earnings among the team members is done in accordance with the wage scales and the actually worked time. For maximum

consideration of the individual contribution, a work involvement factor (KTU) is used. The KTU is used to distribute all types of collective premiums and savings of the wage fund resulting from freeing up of personnel and wage savings from combination of jobs, enlargement of the zones of attendance, and increased volume of performed work.

To objectively determine the personal contribution to the overall results, indexes are monitored, providing a basis for raising or lowering the KTU. In order to correct the KTU in dependence on the quantity and quality of work at the enterprises, a list of factors has been developed with quantitative evaluation of the influence of each of these on the change in the coefficient. The KTU varies between 0 and 2.

Another group largely determining the productivity of NC equipment is the workers involved in maintenance and repairs. Their wage is set in dependence on the reduction in equipment standstill for technical reasons, as well as its maintenance in proper condition.

Shops using NC machines have organized comprehensive maintenance and repair teams. These include workers, engineers and technicians of various professions. The teams bear responsibility for the technical condition and proper working of the equipment assigned to them.

The team's wage consists of the wage scales for the actually worked time, a bonus for work done for absent team members, provided that the team meets the assigned monthly norm, a variable premium based on the particular rules in effect, and a payment for professional skill.

In order to reduce the standstill time of the machines and improve the quality of repairs, there is an additional premium for fulfillment of the monthly repair and maintenance plans in accordance with the preventive maintenance schedules and fulfillment of the assigned norm (15-20 percent of the wage scale), compliance with cleanliness and work culture (5-10), meeting the norm of equipment repair standstill for the entire month with two-shift operation (no more than 11 percent unplanned standstills, 4 percent planned standstills) (20-25 percent premium), and reduction of the monthly equipment repair standstill norm (as much as 20 percent of the wage scale from the incentive fund). If the standstill norm for the group of assigned machines increases above 16 percent, no premium is paid in the last two areas. In event of documented equipment malfunctions resulting from inadequate maintenance or repairs by the fault of the team, the premium is cut in half, or in case of two or more accidents no premium is paid. The maximum remuneration for fulfillment of the established standards is 40 percent from the wage fund and 20 from the incentive fund.

The above-discussed systems notably increase the stake of the workers, engineers and technicians in reducing the standstill of NC machines and maintaining them in constant serviceability.

COPYRIGHT: "Narodnoye khozyaystvo Belorussii", 1986

12717

CSO: 1823/204

INDUSTRY PLANNING AND ECONOMICS

BRIEFS

PRODUCT QUALITY--The Ministry of the Electrotechnical Industry has completed work in recertification of the complete product line in terms of two quality categories. There were 3279 products assigned to the superior quality category, 2989 to the first quality category. For noncompliance with the international technical quality level and violation of the technological discipline, 625 items have been reduced from the superior to the first quality category. The executives of the sector, in particular 12 directors of enterprises, have been subjected to discipline and material penalty by directive of the ministry, as a result of inspections in 1985. The ministry is taking measures to transform the certification into an efficient lever of accelerating the scientific-technical progress in the sector. [Text] [Response of Ye. Orlov, director of the Central Technical Authority and member of the board of directors of the Ministry of the Electrotechnical Industry, to the comment "Products with the Seal of Quality," published in No. 5, 1986] [Moscow EKONOMICHESKAYA GAZETA in Russian No 20, May 86, p 19]

SOVIET-BULGARIAN JOINT VENTURES--Two Soviet-Bulgarian joint scientific production associations have been organized in the area of machine tool construction. One of them is headed by V. P. Kabaidze, general director of the Ivanovo Machine Tool Construction Association im. The 50th Anniversary of the USSR and a Hero of Socialist Labor. The new association incorporates a number of enterprises already in existence or under construction in the Ivanovo oblast and the Bulgarian economic association "Metal-Working Machine Plants," as well as two design bureaus, the headquarters of which are located at Ivanovo, while there are branches in Bulgaria. The specialists of one bureau are occupied in developing documents for a spectrum of modular type metal-working centers, the designers of the other bureau will create science-intensive equipment for flexible manufacturing systems, workshops and automated factories. It is also planned to create a third design bureau, with headquarters at Sofia and a branch at Ivanovo. As their main goal, they have selected the accelerated set-up of production of lathe complexes capable of performing all the basic operations independently by a preassigned program. The advantages of such policy are obvious. It sharply enhances the labor productivity and enables a quick and inexpensive changeover of production, which is the critical condition of scientific-technical progress at the present day. PHOTO: N. A. Bondarevskiy (right), chief designer of the first-manufactured lathe machining center, and A. V. Korotkov, assembly worker foreman, fitting up a new machine tool with a robot and transport system manufactured in Bulgaria. [Text] [Moscow NTR: PROBLEMY I RESHENIYA in Russian No 1, 7-20 Jan 86, p 3]

NC LATHE SERVICING--The correspondence properly notes the problems confronting the Ministry of the Machine Tool Industry in the development of a service organization for NC machine tools. Let me say that 10 centers have already been created for this purpose and it is intended to organize another 15 in major cities of the country, including Orel. Within the Orelremstanok plant in the second quarter of this year the number of factory personnel will be doubled. It is also intended to organize a training of specialists for repair of NC machines in advanced certification classes and establish an additional limit for the acquisition of spare parts. [Text] [By Yu. Segenyuk, head of the Central Machine Tool Repair and Adjustment Agency of the Ministry of the Machine Tool Industry, in response to a reader's letter] [Moscow EKONOMICHESKAYA GAZETA in Russian No 18, Apr 86 p 2]

12717
CSO: 1823/204

OTHER METALWORKING EQUIPMENT

NEW LASER SENSOR DESCRIBED

Moscow NTR: PROBLEMY I RESHENIYA in Russian No 4, 18 Feb - 3 Mar 86 p 5

[Unattributed article: "Laser for Machinebuilders"]

[Text] The Physical Institute imeni P. N. Lebedev of the USSR Academy of Sciences and plant vtuz [Highest Technical School] of the ZIL (Moscow) Production Association adopted a socialist obligation to develop a laser sensor to automate part machining processes that measures the characteristics of surface quality, vibrations, as well as linear and angular movements. This obligation means that an optical sensor must be developed by the end of 1986 for contactless monitoring of production processes and diagnostics of metal-cutting machine tools. Considering the urgency of the development, its participants decided to fulfill the obligation ahead of schedule -- by the opening of the 27th party congress. As a result, the sensor was created a half year ahead of schedule on the basis of semiconductor laser and its characteristics were investigated. The sensitivities of its linear movement is better than a micrometer, angular sensitivity is not lower than one second and the classes of roughness of the investigated surfaces are 14-4. The development serves as a basis for creating a family of specialized sensors to measure machining cleanliness of the surface, change its slope angle, deformation and movements, the shape of the surface and the spectrum of its mechanical vibrations.

2291
CSO: 1823/212

OTHER METALWORKING EQUIPMENT

BRIEFS

HYDRAULIC DIE FORGING -- The SFT 510 press for hydraulic die forging, developed by the Physio-Technical Institute of the BSSR Academy of Sciences, makes it possible to reduce to 1/2-1/3 the cost and time for manufacturing die forged equipment. It is capable of machining intermediate products up to 750mm wide, deform tubular products up to 320mm in diameter and up to 250mm high. [Author unknown] [Text] [Minsk NARODNOYE KHOZYASTVO BELORUSII in Russian No 1, Jan 86 p 2] 2291

PRESS FOUNDATION --Kramatorsk -- The Kramatorsk "Energomashspetsstal" Plant began work on a foundation for a 45,000 ton-force press; the most powerful one in the world. This press is manufactured in the adjacent NKMZ Association with the machinebuilders doing everything exactly on schedule. This means that the giant steel blacksmith will soon need a permanent place at the plant. The installation of the press requires an especially strong foundation, while the ground under the shop which is being built for the equipment weighing tens of thousands of tons, is not stable and the water level is high. Therefore, before starting to pour reinforced concrete in a foundation pit 40 meters deep and 50 meters in diameter, it was decided to freeze this section of the territory. Holes are drilled to a depth of 125 meters (a total of 160 holes). Cold will be sent down the holes to stop the flow of underground waters and strengthen the ground. After creating a frozen island in the ground, the builders will remove the earth from the foundation pit without interference and then will pour the concrete. The Donetsk "Shakhtospetsstroy" Trust Shaft-Sinking Administration of the USSR Ministry of Installation and Special Construction Work will create such an unusual foundation. [By IZVESTIYA correspondent N. Lisovenko] [Text] [Moscow IZVESTIYA in Russian 25 Apr 86 p 1] 2291

PLASMA, MACHINING -- The Kramatorsk Machine Tool Building Association is using a new plasma-machining lathe. The combining of plasma and a cutter made it possible to solve the problem of machining intermediate products with an especially strong surface. Productivity of labor increased 8-fold. [Author unknown] [Text] [Minsk NARODNOYE KHOZYAYSTVO BELORUSSII in Russian No 3, Mar 86 p 2] 2291

NEW MACHINE TOOLS -- The product assortment of the Gomel Machine Tool Units Plant was considerably renovated recently. It now includes radial-drilling portable machine tools -- and actuators of eight models of industrial robots. Dozens of NC machine tools and several robotized complexes have now appeared in the shops of the plant. [Author unknown] [Text] [Minsk NARODNOYE KHOZYAYSTVO BELORUSSII in Russian No 3, Mar 86 p 2] 2291

AUTOMATED LINES AND AGGREGATED MACHINING SYSTEMS

PROBLEMS OF MACHINEBUILDING AUTOMATION

Moscow NTR: PROBLEMY I RESHENIYA in Russian No 4, 18 Feb- 3 Mar 86 p 3

[Article by A. Kostin, candidate of technical sciences, manager of the MTsNTI sector]

[Text] This is the name of a symposium published by the International Center of Scientific and Technical Information (MTsNTI) under the guidance of the CEMA Committee on collaboration in the area of machinebuilding. The symposium is oriented toward leading workers and specialists of scientific, technological and production organizations of the CEMA countries that participated in the implementation of the comprehensive program of scientific technological progress to the year 2000. The editor-in-chief of the symposium is academician K. V. Frolov.

Issues raised at the symposium which will appear in 1986 elucidate problems of robotization, flexible automation of machinebuilding production, software, international evaluation of the technical-economic standards of products, vibration technology and other urgent directions of scientific technological progress in machinebuilding.

The following participated in the preparation of the issues: the Mechanical Engineering Institute imeni A. A. Blagonravov of the USSR Academy of Sciences, the Machinebuilding Department of the CEMA Secretariat, countries participating in the INFORMASH, International Industrial System of Scientific and Technological Information on Machinebuilding, and other interested organizations of the CEMA.

Four issues of the symposium "Problems of Machinebuilding and Automation" will be published annually starting with 1986. The estimated price of each issue is 2 rubles 50 kopecks.

Orders are being accepted from establishments and organizations, as well as from individual subscribers, in the USSR, by magazine No 93 "Book-Mail" of Moskniga addressed to 117168 Moscow, V-168, Krzhizhanovskaya Street, house 14, building 1; tel. 124-71-13. The issues are mailed C.O.D. In other countries orders will be taken care of by trade book organizations cooperating with the "Mezhdunarodnaya kniga" All Union Association.

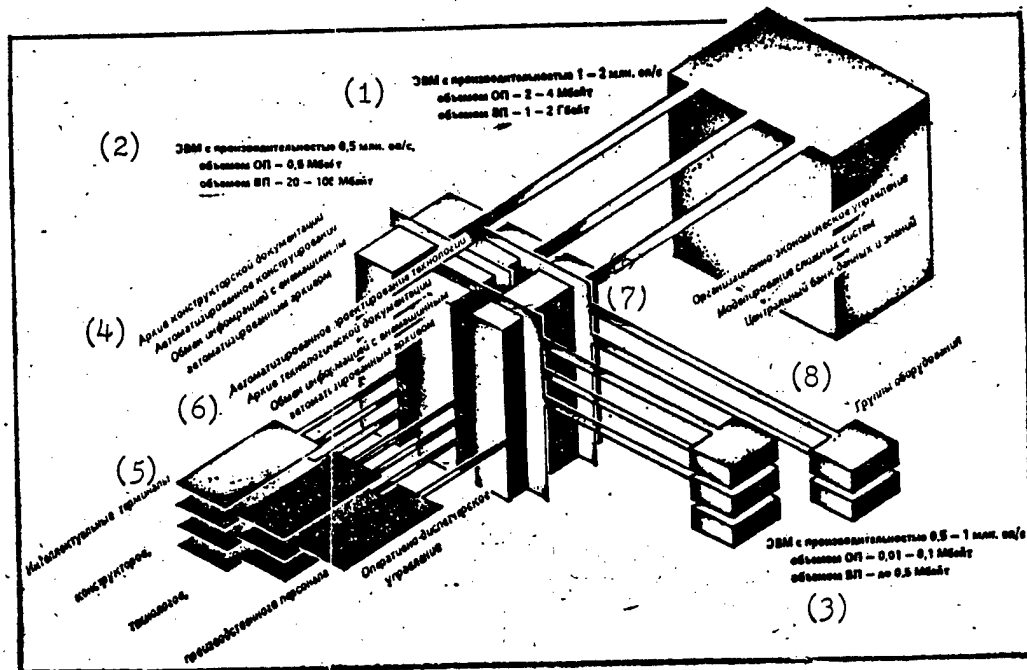

1 -- computer with productivity of 1 to 2 million operations/sec, volume of OP [Direct access memory unit] - 2 to 4 megabytes, volume of VP [Random access memory file] - 1 to 2 megabytes; 2 -- computer with productivity of 0.5 million operations/sec, of volume - 0.5 Mbytes; VP -- 200 to 100 Mbytes; 3 -- computer productivity of 0.5 to 1 million operations/sec; volume of .01 -.1 Mbytes; VP 2.5 Mbytes; 4 -- archives of design documentation, automatic design, data exchange with external automatic archives; 5 -- Intellectual terminals: designers, technologists, production personnel, operational-dispatcher control; 6 -- automatic technology design, archives of technological documentation, exchange of information with outside archives; 7 -- organization-economical administration, simulation of complicated systems, central data and knowledge file; 8 -- equipment groups.

We present here one of the publications of the symposium.

The figure shows the schematic system of the comprehensive automation of the design, development and manufacture of products in small series machinebuilding production (KAPRI), being created in the Atomic Energy Institute imeni I. V. Kurchatov. The special feature in the ideology of the KAPRI system is the orientation, from the very start, on the complete start-to-finish cycle "design-preparation-production-manufacturing."

The area of application of the KAPRI system is experimental machinebuilding production that provides for creating large experimental power test stands; characterized by individual and small series scales (average number of one kind of parts is 10 pieces), with a wide product list (of up to 20,000 kinds a year).

Practical results of introducing individual problems and subsystems of this special design engineering complex for scientific research were obtained in cooperation with the Institute of Applied Mathematics imeni M. V. Keldysh.

2291

CSO: 1823/207

AUTOMATED LINES AND AGGREGATED MACHINING SYSTEMS

QUALITY IMPROVEMENT MEASURES IN INDUSTRY

Moscow EKONOMICHESKAYA GAZETA in Russian No 19, May 86 p. 5

[Article by V. Neverova, editor of the factory newspaper "Stankostroitel":
"Following a Program of Quality"]

[Text] The assortment of manufactured items is being actively updated at the Moscow Plant for Grinding Machines. Recently, trial models of 18 and established series of 14 new machine tool models and two automatic lines for machining of parts for the Don-1500 harvester have been produced. The share of high quality production exceeds 83 percent of the total volume.

But still the technical level of individual machines lags behind the needs of the day, both with respect to reliability and level of automation. Automatic machines and automatic lines for enterprises with mass production and high-precision, fast-setup lathes for small series and individual orders are not sufficiently produced.

In the 12th Five Year Period the designers of the plant have been set the goal of substantial increase in the technical level and competitiveness of the technology. They must design flexible manufacturing modules and a NC wheel straightening implement. A NC system is being developed, using micro-processors in conjunction with a programmable controller. The machine tools will substantially increase their use of electronics and automation, while new structural materials, progressive straightening tools and cutting tools will appear.

In view of these goals, the enterprise is defining a comprehensive program of production quality enhancement, a part of the Moscow municipal program "Quality." Its implementation involves the adoption of progressive technological processes. A major reorganization of the operation of all the factory services, primarily maintenance, is needed.

The factory management and each workshop are holding "quality days" each week. There are well-equipped measurement laboratories and inspection points. Test stands are used to check the reliability of the elements during assembly. In such an environment, increased vigilance is demanded on the part of the metrological and inspection departments.

There are quite a few enthusiastic workers, actively introducing progressive work methods and procedures and various appliances. During the course of a discussion and study of the documents of the 27th Party Congress, the workers taking part in the political and economic educational system conceived an initiative: "Each pupil is a rationalizer."

During the first quarter of this year, innovators introduced nearly twice as many proposals as was expected. To make the creative process more goal-oriented, the question of creating quality clubs is now under consideration.

12717

CSO: 1823/205

AUTOMATED LINES AND AGGREGATED MACHINING SYSTEMS

UDC A 62-229.7.621.941.1

TURNING ROBOT-TECHNOLOGICAL COMPLEX DESCRIBED

Moscow MEKHAZATSIYA I AVTOMATIZATSIYA PROIZVODSTVA in Russian No 3, Mar 86
pp 9-10

[Article by G. N. Sokolov, N. A. Sorokin and S. A. Suvorov, engineers]

[Text] The use of industrial robots in automatic complexes using NC machine tools makes possible a considerable increase in the productivity of labor, insures high quality of output, as well as creating flexible production systems capable of being easily readjusted when the product is changed. As a rule, in group servicing of machine tools, the greater effect is achieved when the robot function includes not only operations of setting up on and removing parts from the machine tool, but also the transportation between machine tools.

One enterprise developed, manufactured and introduced the robot equipment complex which is made for machining a wide list of solids of revolution type 330 to 880mm long, up to 160mm in diameter and weighing up to 40kg in small series and series production.

The complex can machine exterior and interior surfaces with stepped and curvilinear shapes of various complexities in one or several passes, and cut threads.

The parts can be mounted in machine tools in a self-centering chuck; in a self-centering chuck with the support by the tail center; with a jaw chuck with a floating center and cams.

The RTK includes two 16K30F335 NC lathes modernized for operation with the SM40.F2.80.01 robot, two loaders, two unloaders, an apron conveyor for removing chips and barriers for the complex (Fig. 1).

The machine tools were modernized so that they can operate jointly and automatically with the industrial robot. The following were installed for this purpose: a drive to move the barrier, a device to monitor the position of the tail spindle and an apron conveyor to remove chips from the machine tool.

The loader is used for accumulating intermediate products and feeding one intermediate product to the initial position. It is a welded frame with a hydraulic cylinder mounted on it which, through a system consisting of a rack-gear-ratchet-sprockets- chain, advances rows of prisms at a constant pace. Under the last row of prisms, there is located a cylinder with prisms attached to a rod which lifts the intermediate product to a height required for passing the jaws of the robot's grip. The capacity of the loader is nine intermediate products.

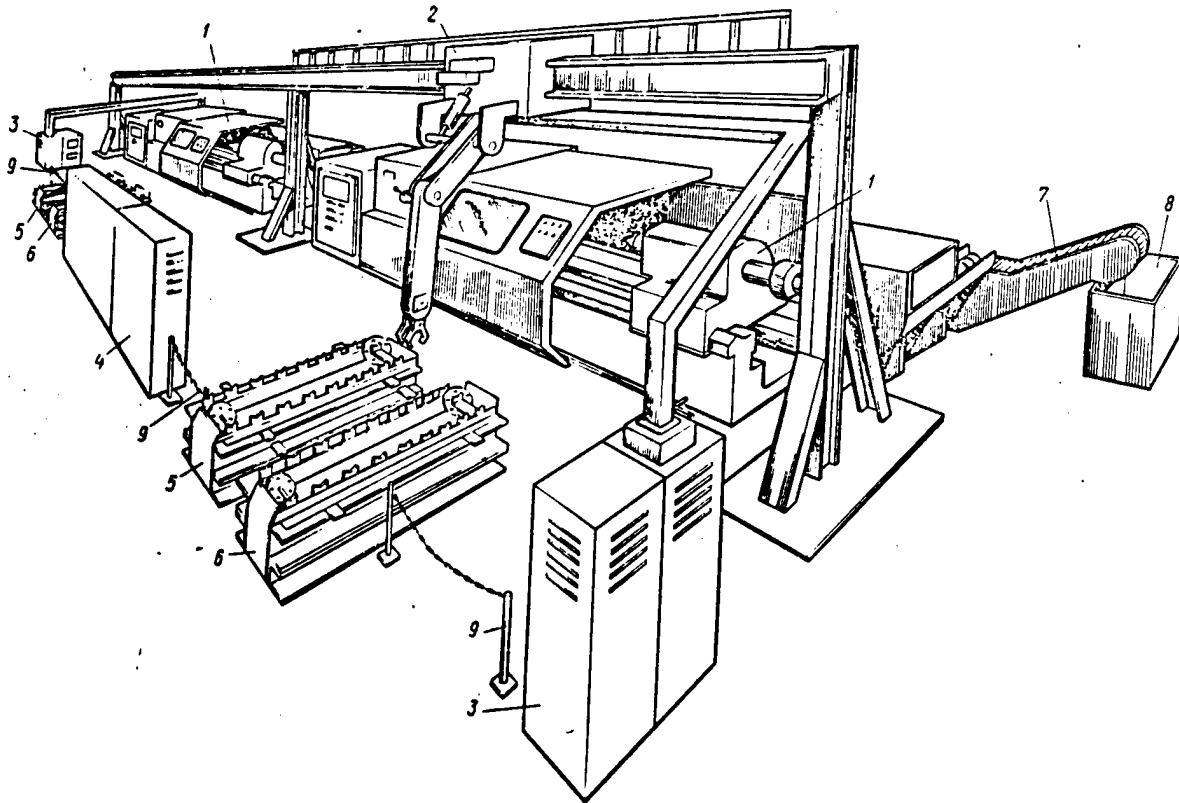

Fig. 1. Robot-technological complex using 16K30F335 machine tools and SM40.F2.80.01 robot:

1 -- machine tools; 2 -- robot; 3 -- NC rack for machine tool; 4 -- NC rack for robot; 5 -- loader; 6 -- unloader; 7 -- conveyor for removing chips; 8 -- tank for chips; 9 -- barriers.

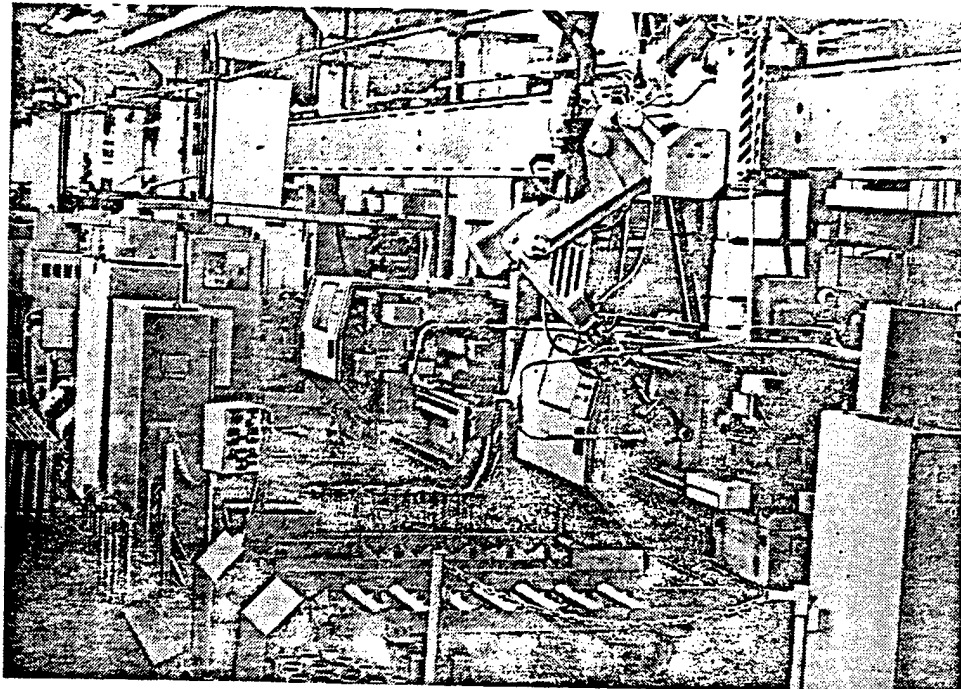

Fig. 2. Technological robot complex.

The design of the unloader for receiving the machined part from the robot and moving it to the storage unit is similar to that of the loader, with an opposite sequence.

The apron conveyor, consisting of a frame, drive and chain with an apron deck removes the chips.

The complex is equipped with a data system and corresponding communications channels with an NC device which makes it possible to build an efficient safety system whose goal is to prevent man and industrial robot from being in one work position simultaneously.

The enclosure of the complex meets safety requirements. The enclosure devices consist of three pairs of cabinets; a chain is connected rigidly to one of the cabinets, while the other second end of the chain has a lock which, by contacting the last switch, records the moment a man enters the working space of the industrial robot.

The safety system operates as follows. When the lock is removed from the cabinet as a man enters the working area, a signal is issued that prevents the entrance of a robot to the given place.

If, however, the industrial robot is in that place, or is entering it and recorded by contactless switches, an instruction is given to stop the robot, which enters the NC drive for the logic converter unit.

Three operating versions are provided:

sequential machining of parts on machine tools adjusted to do various operations;

parallel machining of one kind of parts on machine tools adjusted to perform a similar operation;

parallel machining of two kinds of parts on machine tools adjusted for doing corresponding operations.

The RTK operator monitors the proper operation of the complex, the timely supplementing of the loader with intermediate products and the unloading of the unloader.

RTK specifications:

Machined product	Shaft
Weight of intermediate product, kg	up to 40
Length of machined product, mm	330-880
Diameter of machined product, mm	30-160
Productivity, pirces/year	up to 28,000
Size of complex, mm	14,700 x 6200 x 3800

The introduction of the RTK (Fig. 2) made it possible to eliminate the monotonous low-productive labor of the machine tool operator, double the productivity of labor and free three production workers. The saving was 27,000 rubles.

COPYRIGHT: Izdatelstvo "Mashinostroyeniye", "Mekhanizatsiya i avtomatizatsiya proizvodstva", 1986

2291

CSO: 1823/197

AUTOMATED LINES AND AGGREGATED MACHINING SYSTEMS

UDC Δ 62-229.7: 621.941.23

ROBOTIZED TECHNOLOGICAL COMPLEXES USING PR SM40Ts4011 DESCRIBED

Moscow MEKHAIZATSIIYA I AVTOMATIZATSIIYA PROIZVODSTVA in Russian No 3, Mar 86
pp 10-11

[Article by Yu. L. Golinets, S. I. Murayenko, B. S. Ustinov]

[Text] In series production of rolling tools the basic volume of work is machining on metal-cutting automatic machine tools with manual loading and unloading.

To mechanize and automate these operations, two robotized technological complexes (RTK) were designed and introduced for the automatic machining of mandrels weighing up to 15kg and 40kg.

The first complex (Fig. 1) machines mandrels automatically 75-110mm in diameter, 230-250mm long and weighing 5 to 15kg. The complex includes two model 1713 automatic lathes, an NC type SM40Ts4011 industrial robot, a two-deck disk magazine for intermediate products and a storage unit for the machined mandrels.

The RTK operates as follows. Before automatic operation starts, the operator loads the magazine with intermediate products, prepares machine tools, PR and magazine for automatic operation.

The automatic system is switched in when the preparation is completed. The PR starts to implement the cyclic program of loading and unloading. After rough machining of the mandrel on the first machine tool, the PR removes the mandrel from the machine tool, turns and installs it on the centers on the second machine tool, and switches in the automatic system. The machine tool does the finish machining of the mandrel. The PR takes from a cell in the first deck of the magazine, the PR a mandrel, rotates to the first machine tool, installs the mandrel on its centers and switches in the automatic control of the machine tool. The machine tool does the rough machining of the mandrel.

After completing machining of the part on the second machine tool, the PR rotates to the storage unit and drops the mandrel into the storage unit. After that, the PR rotates to the machine tool and stops. After machining is completed the PR takes the mandrel from the machine tool and the cycle is completed with the exception of unloading the magazine. In this cycle, the robot takes the mandrel from the cell of the second deck of the magazine, after which the magazine will turn by an angle equal to one cell and, in the following cycle, the manipulator will again take the mandrel from the cell of the first deck of the magazine, etc.

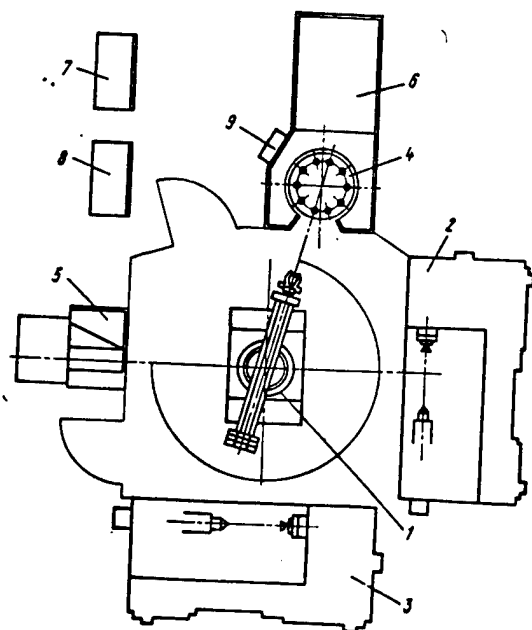

Fig. 1. An RTK arrangement for machining mandrels weighing up to 15kg.

1 -- industrial robot model SM40Ts4011; 2,3 -- hydraulically operated copying semi-automatic lathe; 4 -- disk magazine; 5 -- storage unit; 6 -- loading table; 7 -- PR control panel; 8 -- RTK control cabinet; 9 -- RTK control panel.

The second RTK is designed for the automatic machining of mandrels 20-110mm in diameter, 350-950mm long and weighing 3-40kg. The complexes (Fig. 2) include the following: a milling-centering machine tool, an SM40Ts4011 industrial robot and a magazine storage unit consisting of a discriminator, dispenser, pusher, stop and conveyor.

The RTK operates as follows. Before automatic operation begins, intermediate products of mandrels are loaded to the shelving before the discriminator by a crane. The operator prepares the machine tool, the magazine-storage unit and switches in the automation. The discriminator lays the intermediate products out in one row on the shelving in front of the pusher. The pusher pushes the

intermediate product to the stop and returns. PR takes the intermediate product from the channel, loads it in the machine tool and switches on the automation. When machining is completed, the robot takes the intermediate product from the machine tool and places it on the conveyor. The intermediate product is moved by the conveyor to the container. This completes the machining cycle of one intermediate product. The following machining cycle is similar to the first.

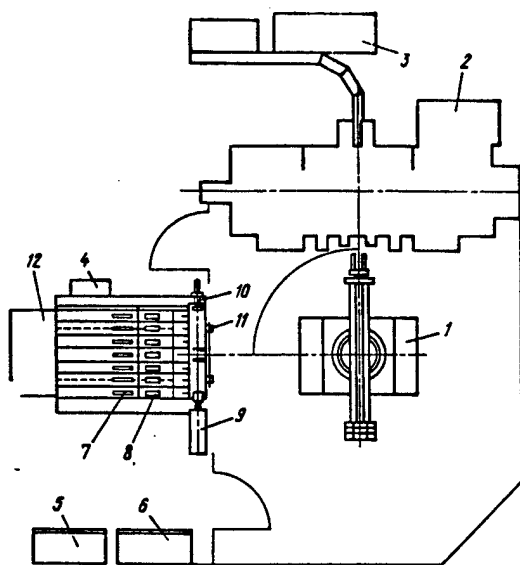

Fig. 2. Arrangement of RTK for machining mandrels weighting up to 40kg:

1 -- industrial robot SM40Ts4011; 2 -- milling-centering semiautomatic machine tool; 3 -- cabinet for machine tool control; 4 -- RTK control panel; 5 -- PR control panel; 6 -- cabinet for RTK control; 7 -- discriminator; 8 -- dispenser; 9 -- pusher, 10 -- stop; 11 -- conveyor; 12 -- container.

The introduction of two RTK freed six workers.

COPYRIGHT: Izdatelstvo "Mashinostroyeniye", "Mekhanizatsiya i avtomatizatsiya proizvodstva", 1986

2291

CSO: 1823/197

AUTOMATED LINES AND AGGREGATED MACHINING SYSTEMS

UDC 681.2 + 621.91

CREATION, USE OF GPS LATHE MACHINING MODULES REVIEWED

Moscow MEKHANIZATSIYA I AVTOMATIZATSIYA PROIZVODSTVA in Russian No 3, Mar 86
pp 11-14

[Article by N. A. Arkhipenko, candidate of technical sciences]

[Text] The creation of flexible production systems (GPS) is a strategic goal that defines modern problems in automating production processes.

At present, the basic principles in designing GPS have been determined, their classification was developed and their composition defined (GOST 26228-85). This made it possible to start a stage-by-stage realization of the individual component parts, as well as the GPS as a whole. The concepts of creating GPS include their design, the hierarchy of control, the group method of machining, the flexibility of technical facilities, etc.

By modularity, we mean not only the design completeness but also the functional completeness, i.e., each GPS module (machining module, transportation module, etc.) must be independent in its application.

Some of the basics in GPS metalworking are modules that include machine tools, industrial robots (PR), storage-feeding devices (MPU) and other equipment. Machining modules can be classified according to the type of machining as lathes, milling, etc.

By flexibility is meant the capability of the technical devices to achieve, within required limits of quality indicators given functions with changes in the initial and final characteristics of the products being manufactured. In our case, this means modules functioning in small series and rapidly changing large series and mass production.

In automatic production facilities, modules with manual readjustment can be used for machining other parts, while in GPS -- only modules with automatic readjustment can be used.

Examples of modules of lathe machining with manual readjustment are modules type 1M, 2M, 3M and 4M using machine tools TPK-125M, 1I611PF Z, IG340PTs and others using cyclic PR RF-202M, RF-204M, RF-205M and RF-301M. The characteristics of PR and modules are shown in Tables 1 and 2. The advisability of using modules with manual readjustment is basically due to the rapidly changing products in modern instrument building. With such models, it is possible to

create automatic sections and lines for the production, for example, of parts for home radios. When manufacturing parts from rods, it is possible to recommend the use of the modules in pairs, one of which would manufacture parts from the rods, while the other machines the other end of the rod.

As shown by experience, the efficient use of these modules is achieved when large lots of parts are being made, which is characteristic for mass and large scale production. This is due to the complexity of their readjustment when changing over to another product list of parts. As an example, in Fig. 1 is shown the results of calculating the annual economic effect for various versions of using module M1, depending on the time between readjustments T_{bper} of the module and the time of the readjustment T_{per} itself. The curve shows that reducing the readjustment time from two hours, as shown in the certificate, to 30 minutes makes it practical to use the module in small series production. To do this, it is necessary to have a set of changeable jaws for the grip and a set of tongs or readjustable chucks. The tool must also be changed automatically. As a storage-feed device, the use of bunkers with changeable trays or readjustable tray type magazines is recommended.

The advantages of modules with manual readjustment are: relatively low cost of technical devices, simplicity of adjustment and operation and high speed which makes it possible to use them for manufacturing parts with small machining time.

The shortcomings are: limited functional possibilities of PR, their small lifting capacity which, a number of times, makes it more difficult to use universal grips as well as a considerable reduction in effectiveness in manufacturing a small series of parts.

The cited analysis of the technological processes at enterprises in the sector indicated that there are essential possibilities for using GPS modules with lathes 16K20T1, 16K20T1-01, 16B16T1 and IV340F30 (and later -- with series ST machine tools being developed in the sector), serviced by PR types M-11, M-21, "Elektronika NTsTM-01" and "Granat-25." The technical characteristics are shown in Table 3.

Modules with automatic readjustment have a considerably smaller readjustment time which provides premises for creating PGS of a fairly high level that may be effective for small series multiproduct production.

We will consider certain promising versions of designing modules for turning with automatic readjustment and possible arrangements in sections. The technical characteristics of the given modules are shown in Fig. 4.

The arrangement of a module with PR M-11 is shown in Fig. 2. Machine tool 1 machines parts weighing up to 5kg. Robot 2 unloads and loads parts from a fixed position set by the storage device-feeder (NPU) 3. The NPU has four positions on which detachable pallets 4 with intermediate products and parts (positions B, C and D) and unloader (position A) are mounted. Position C is made in the form of a timing table; the pallet mounted on it rotates to a position where the robot loads the intermediate product and accepts machined parts. Positions B and

D are intermediate. Reloader A feeds the pallets with the intermediate products from an automatic transport cart to position D. Pallets with machined parts from position C enter position B. The reloader transfers pallets from position B to transport cart 5. The NPU contains a device which monitors the diameter of the intermediate products when they leave the loading position. A doubled PR grip reduces loading-unloading time. The module is controlled either from a panel, or from the single control system for the module. The module can communicate with a higher level system.

Table 1

Characteristic of cyclic industrial robots

(1) Параметры	(2) Тип ПР (3)			
	РФ-202М	РФ-204М	РФ-205М	РФ-301М
(4) Номинальная грузоподъемность суммарная/на одну руку, кг	0,4/0,2	2/1	3/1	1
(5) Число степеней подвижности	6	6	6	5
(6) Максимальная абсолютная погрешность позиционирования, мм	0,5	0,1	0,1	0,5
(7) Число рук	2	2	2	1
(8) Рабочая зона:				
(9) Наибольший вылет руки, мм	665	665	800	300
(10) Максимальные линейные перемещения по осям, мм:				
X	200	200	300	496
Y	30	30	30	496
Z	30	30	30	160
(11) Максимальные угловые перемещения, градус:				
(12) поворот колонны	240	240	120	—
(13) поворот схвата	180	180	180	90; 180
(14) Привод	(17)	Пневматический		
(15) Число одновременно управляемых движений по степеням подвижности	3	3	3	3
(16) Масса манипулятора, кг	34	35	54	120

1 -- Parameters; 2 -- PR type; 3 -- RF-301M; 4 -- Nominal total load-lifting/one arm, kg; 5 -- Number of degrees of mobility; 6 -- Maximum absolute positioning error, mm; 7 -- number of arms; 8 -- working zone; 9 -- maximum reach of arm; 10 -- maximum linear movements along axes, mm; 11 -- maximum angular movements, degrees; 12 -- rotation of column; 13 -- rotation of grip; 14 -- drive; 15 -- number of simultaneously controlled movements along degrees of mobility; 16 -- weight of manipulator, kg; 17 -- Pneumatic.

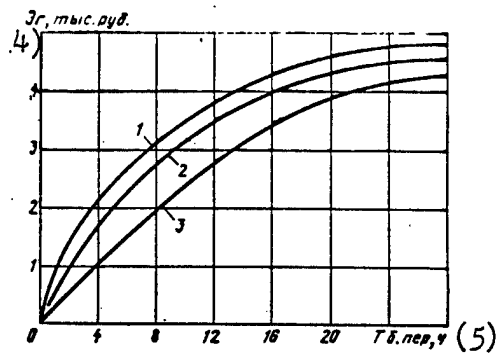

Fig. 1. Relationship between effectiveness of module 1M and average time between readjustments:

1 -- $T_{per} = 0.5$ hour; 2 -- $T_{per} = 1$ hour; 3 -- $T_{per} = 2$ hours; 4 -- annual effect, 1000 rubles; 5 -- $T_{b.per}$, hours

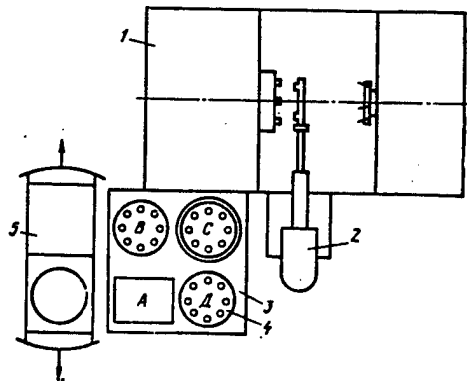

Fig. 2. Structural arrangement of module with PRM-11

Table 2

Characteristic of modules with manual readjustment

(1) Параметры	Тип модуля (15)			
	1М	2М	3М	4М
(2) Состав модуля	(11) ПР РФ- 202 М, станок, НПУ	ПР РФ- 204 М, 2 станка, НПУ, транспорт- ное уст- ройство	ПР РФ- 204 М, 1 станок, НПУ	ПР РФ- 205 М, 1 станок, ПР РФ- 301 М
(3) Габаритные размеры обрабатываемых деталей, мм:				
(4) диаметр	10-50	10-50	10-50	10-100
(5) длина	10-50	10-50	10-50	10-100
(6) Масса обрабатываемых деталей, кг	0,2	1	1	1
(7) Время:				
(8) непрерывной работы НПУ при полной загрузке деталями, ч	4	4	4	4
(9) переналадки, ч	2	2,5	2	2,5
(10) загрузки-разгрузки станка, с	10	10	10	10

1 -- Parameters; 2 -- composition of model; 3 -- size of machined parts, mm;
 4 -- diameter; 5 -- length; 6 -- weight of machined products, kg; 7 -- Time;
 8 -- continuous time of NPU operation at full load, hours; 9 -- readjustment, hours;
 10 -- loading-unloading machine tool, seconds; 11 -- PR RF-202M; 12 -- 1 machine tool;
 13 -- NPU; 14 -- transport device; 15 -- type of module.

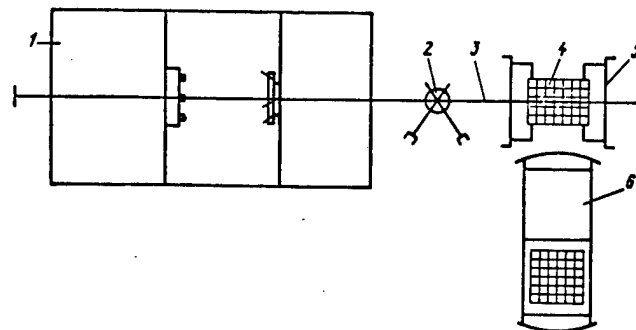

Fig. 3.. Structural arrangement of module with PRM-21

Table 3

(1) Параметры	Тип ПР			
	(2) М-11	М-21	(3) «Электроника» НТЦМа	(4) «Гранат-2,5»
Номинальная грузоподъемность, суммарная/на одну руку, кг (5)	5	6/3	2/3,5	2,5
Число степеней подвижности (6)	6	4	5	5
Максимальная абсолютная погрешность позиционирования, мм (7)	0,5	0,5	0,5	0,16
Число рук (8)	1	2	1	1
Рабочая зона: наибольший вылет руки, мм (9)	960	925	300	865
Максимальные линейные перемещения по осям, мм: (10)				
X (11)	150	2000...6000	300	—
Y (12)	—	—	300	—
Z (13)	150	0...550	150	—
Максимальные угловые перемещения, градус: (14)				
вращение колонны (15)	0...±60	—	90	320
качание плеча (16)	90	—	—	250
качание предплечья (17)	—	—	— (23)	270
качание кисти (18)	—	—	—	200
вращение схвата (19)	180 (22)	180	180	740
Вид привода (20)	Электрический и пневматический	Электрический и пневматический	Электроме- ханический	Электроме- ханический
Вид управления (21)	Позиционно-цикловое	Позиционно-цикловое	Позиционное	Позиционное и контурное
Число одновременно управляемых движений по степеням подвижности (22)	1	2	1	5
Масса манипулятора, кг (23)	120	300	60	75
	(24)		(25)	(26)

1 -- Parameters; 2 -- PR type; 3 -- "Elektronika" NTsTMa; 4 -- "Granat-2.5"; 5 -- Nominal load-lifting capacity, total per one arm, kg; 6 -- Number of degrees of mobility; 7 -- Maximum absolute positioning error, mm; 8 -- Number of arms; 9 -- Working zone; 10 -- maximum reach of arm, mm; 11 -- Maximum linear movements along axes; 12 -- Maximum angular movements, degrees; 13 -- rotation of column; 14 -- rolling of arm; 15 -- rolling of forearm; 16 -- rolling of wrist; 17 -- rolling of grip; 18 -- type of drive; 19 -- type of control; 20 -- Number of simultaneously control movements according to the degrees of mobility; 21 -- Weight of manipulator, kg; 22 -- Electrical and pneumatic; 23 -- Electromechanical; 24 -- Position-cyclic; 25 -- Position; 26 -- Position and contour.

The advantages of the given module are: comparative simplicity of PR and its fairly high load-lifting capacity which makes it possible to use highly-universal grips. A shortcoming is the limited use of the NPU capacity for storing parts (due to the round shape of the pallets) which determines the applicability of this module for manufacturing parts with considerable machining time. As a rule, these are parts weighing more than 1kg. The round shape of the pallets may lead to underutilization of the cell capacity of the warehouse which are usually of a rectangular shape. Another shortcoming may be the complexity of its NPU. A PR may be used to change pallets which move with respect to the modules. Such a

PR must have a load-lifting capacity of 20kg or higher and move over floor rails or on a suspended monorail. In principle it is possible to use a rectangular box in this module as an NPU with a PR-stacker (for example, type RF-301M) which feeds intermediate products piece-by-piece to the loading position of the PR, as well as receiving and stacking machined parts into cells of packing boxes.

Table 4

Characteristic of modules with automatic readjustment

(1) Параметры	(2) Тип модуля			
	(3) с ПР М-11	с ПР М-21	с ПР «Электроника NTsTM-01»	(5) с ПР «Гранат-2.5»
(6) Габаритные размеры обрабатываемых деталей, мм:			(4)	
длина (7)	20...150	6...50	10...160	10...50
диаметр (8)	15...200	6...200	10...150	10...100
(9) Время загрузки-разгрузки станка, с	15	20	20	15
(10) Время переналадки, мин	30	30	30	30
(11) Число деталей в одной кассете НПУ, шт	24	до 64	до 81	до 64
(12) Ориентировочное время смены кассет в автоматическом режиме, с	60	60	60	60
(13) Типаж основного технологического оборудования	1Б616Ф3С1, 1Т11Р2412, 1П717Ф3 (14)	16Б16Т1, 16К20Ф3 (15)	16К20Т1, СТП-220РП (16)	ТПК-125М, 1И611ПФ3 (17)

1 -- Parameters; 2 -- Type of module; 3 -- with PR M-11; 4 -- with PR "Elektronika" NTsTM-01; 5 -- with PR "Granat-2.5"; 6 -- Size of parts; 7 -- diameter; 8 -- length; 9 -- loading-unloading time of machine tool, sec.; 10 -- Readjustment time, min.; 11 -- number of parts in one NPU cassette, pieces; 12 -- Approximate time for cassette change in automatic mode, sec.; 13 -- types of basic technological equipment; 14 -- 1Б616Ф3С1, 1Т11Р2412; 1П707Ф3; 15 -- 16Б16Т1, 16К20Ф3; 16 -- 16К20Т1, СТП-220РП; 17 -- ТПК-125М, 1И611ПФ3.

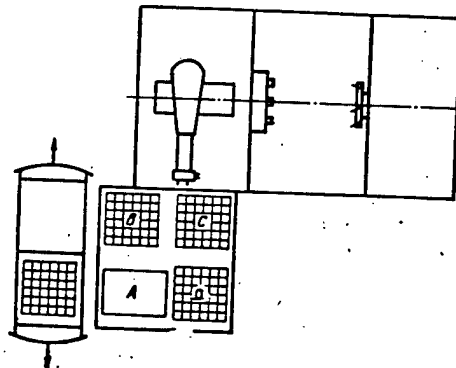

Fig. 4. Structural arrangement of module with PR Elektronika NTsTM-01.

To machine parts of the shaft type 150mm or longer, it is advisable to use module M-21 (Fig. 3). Robot 2 moves along crane 3 between the NPU5 and machine tool 1, transferring intermediate products from the packing box of the NPU 4 to the chuck of the machine tool and parts from the chuck to the cells of the packing box.

To provide for the grasping of intermediate products and the stacking of pieces into packaging cells we envision the positionally controlled transfer of the packaging perpendicularly to the crane's axis.

Robot cart 6 moves between guiding NPU (under the packing box). The position of the packing box is changed in its vertical movement (raise-lower) by lifting devices mounted on the robot cart.

Advantages of the module are: fairly simple coupling to the robot carts, free access to the machine tool and a comparatively simple PR control. A shortcoming may be the considerable transport movement of the robot which limits its effectiveness with parts with short machining cycles. Moreover, the storage unit-feeder device is fairly complicated. For the considerable machining time of parts one PR can service two and more machine tools which increases the effectiveness of using the robot.

Modules with "Elektronika NTsTM-01 PR (Fig. 4) and "Granat-2.5" PR (Fig. 5) utilize the working volume of NPU in warehouse cells more fully. The composition of the modules is similar to that in Fig. 2. The change in the packing is made like the change in the pallets. These modules can be combined conveniently with a robot cart as well as with a suspended monorail transport. The effectiveness of the "Granat-2.5" PR is due to the convenience of combining it with equipment, as well as the possibility of doing additional operations, for example, readjusting the chuck, cleaning off the fins, etc. It is advisable to equip the module with a set of changeable grips for the PR. A shortcoming of the Elektronika NTsTM-01" PR is the limited number of versions for linking with machine tools (installation on headstock). A shortcoming of a module with a "Granat-2.5" PR is the complexity of the software and the comparatively high cost.

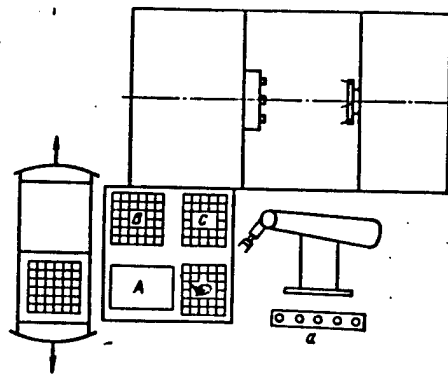

Fig. 5. Arrangement of module with Granat-2.5 PR (changeable grips) (a).

An analysis indicates that the effectiveness of using GPS modules for turning is related to the solution of such problems as providing reliable operation of technical facilities, efficient operational monitoring of the parameters of parts, tools, diagnostic equipment, automation of technical facilities, creation of integrated device and programming systems that provide local module control.

A study of advanced domestic and foreign experience makes it possible to define basic ways to develop and improve GPS modules for turning with automatic readjustment. It appears advisable to carry out the work stage-by-stage.

Stage 1. Create modules with low independence. In these modules, the following processes are automated: machining of parts, loading and unloading machine tools, removal of chips from the cutting zone, clamp and unclamp the chuck, monitor the diameter of the intermediate product. The control system consists of local control systems for the machine tool and PR linked to the control panel by the module. In operation, these modules require the interference of man in readjustments and in the process of operation (loading-unloading, NPU, monitoring, etc.).

Stage 2. Create modules with average independence. In these modules, there are, additionally, automated removal-installation of pallets in the NPU and output monitoring of dimensional characteristics of parts. The machine tool and PR are controlled either by local systems, or by a single system of module control of the CNC type. In operation, these modules require considerably less labor by an operator. Moreover, they can be combined with automatic transportation systems which makes it possible to combine them in flexible production complexes.

Stage 3. Creation of modules with a high degree of independence in which, in addition to the conditions in stages 1 and 2, the following are also automated: readjustment (or change) of chuck, change of tools, parameters of parts and tools are monitored actively, and adaptation of cutting modes and diagnostics of the condition of the equipment facilities are achieved. All these modules must have links to the control system of the upper level.

In conclusion, several general rules for organizing GPS on the basis of modules can be stressed. In creating GPS, it is necessary to have a specific individual approach which takes into account the special features of production that should be automated. The selection of modules, their number, the general structure of the GPS, the spatial position of the modules and their interrelation should be done by using simulation methods. In modeling, the effect of external linkages on the GPS should be taken into account. The following criteria of GPS optimality may be assumed: minimum capital and current expenditures for a given productivity, maximum productivity for given costs, etc. An analysis indicates that the higher the functional possibilities of the modules and their independence, the less the GPS disturbs the existing linkages in production (informational and material), the greater its effectiveness.

COPYRIGHT: Izdatelstvo "Mashinostroyeniye", "Mekhanizatsiya i avtomatizatsiya proizvodstva" 1986

2291

CSO: 1823/197

AUTOMATED LINES AND AGGREGATED MACHINING SYSTEMS

BRIEFS

ROBOTIC COMPLEX--Odessa--Shafts for hydraulic motors and hydraulic pumps are being manufactured without human involvement by a production line introduced at the Odessa Stroygidravlika Association. The robotic computer-controlled complex replaces 15 machinists. Its placement in service inaugurates the Promrobot-90 program of the sector, developed for the 12th Five Year Period. [Text] [Moscow SELSKAYA ZHIZH in Russian 2 Feb 86 p 1]

ROBOTIC SYSTEMS--Kuybyshev--The Central Volga Machine Tool Plant has met one of its main pre-congress responsibilities. It has developed a prototype of a new "manufacturing center" type NC lathe, model 1716PFU. It can carry out 12 metal-working operations. An excellent start has also been made in the series production, fulfilling the January plan in all respects. The first 10 NC robotic systems have been shipped out. A total of 150 such complex machines will be manufactured in the first year of the five year period, i.e., robots will service every fifth NC machine tool. By the end of the 12th Five Year Period, the robotic systems will be the main product of the plant. [Text] [By A. Vorobyev] [Moscow SOTSIALISTICHESKAYA INDUSTRIYA in Russian 18 Feb 86 p 2]

AUTOMATED MACHINING COMPLEX--A second automated machining complex (MAK) has begun operation at the Machine Plant im. 60th Anniversary of the USSR (Ustinov). It consists of a set of flexible adjustable modules, each controlled from an Elektronika-60 minicomputer, and an automated materials handling and stacking system. The entire complex is supervised by a SM-4 computer. The turning, milling and drilling of that number of parts currently handled by the MAK would take no less than 230 universal lathes. There are also just over 50 machining centers in operation here. The nearly twofold reduction in the fleet of lathes has reduced the number of attending personnel and reduced the production space by 500 m². [Text] [Moscow MASHINOSTROITEL in Russian No 3, Mar 86 p 19]

NC MACHINING CENTER--Lithuanian SSR--The Vilnyus Calculator Plant im. Lenin has completed a modernization of the equipment in the machinist shop; the last NC machining center has been put into service. These centers are built by the Vitebsk Lathe Plant im. Kirov. Each center replaces several lathes. [Text] [Moscow EKONOMICHESKAYA GAZETA in Russian, No 21, May 86 p 4]

1 August 1986

ROBOTIC PRODUCTION LINE--The "Lathe Plant im. Sergo Ordzhonikidze" Production Association, following the plans of the Design Bureau for Automated Production Lines and Integrated Machine Tools and with participation of the Stankin students, is assembling a new automated production line 1L487, equipped with a robot. Introduction of this line at the Moscow "Dinamo" Plant is expected to produce an economic impact no less than 140,000 rubles. The workers have taken on the responsibility of completing the assembly of the line by the opening of the 27th Congress of the CPSU. Photo: Assembly of the automatic line in progress at assembly shop No. 17. [Text] [Moscow NTR: PROBLEMY I RESHENIYA in Russian No 2, 21 Jan - 3 Feb 86 p 3]

12717

CSO: 1823/205

ROBOTICS

ACADEMY OF SCIENCES MEMBER REVIEWS ROBOTICS

Moscow TEKHNICHESKAYA ESTETIKA in Russian No 1, Jan 86 p 18

[Article by Ye. P. Popov, corresponding member of the USSR Academy of Sciences, manager of "Robototekhnika" Scientific Training Center of the USSR Academy of Sciences and the USSR Minvuz]

[Text] Ergonomic investigations are essentially capable of increasing the efficiency of robot equipment, especially where remote controlled robots and manipulators are used. In the MVTU [Moscow Higher Technical School imeni N. E. Bauman] scientific research began in the sixties, related to systems for the remote control of manipulators. At that time, everybody knew about copying manipulators for working in enclosed chambers with radioactive materials (then they began to be used in other areas also under various extreme conditions).

A human operator observed the process in the chamber visually through the chamber glass or on a TV screen. The action of the operator in the copying system was very inefficient and tiring. Ergonomic investigations have shown that, in addition to the visual observation channel, the human must be given a feel of the forces in the work done in the chamber. This would make his actions closer to the normal working process.

Corresponding equipment was developed on various versions (so-called reversible systems and two-sided action systems). As a result, the efficiency of the operator's action with the copying manipulator with respect to speed and quality of fulfilling the operations increased literally by an order of magnitude. The various versions of systems with the feel of forces were dictated by the fact that a man cannot always apply his efforts continuously and it is necessary to free him temporarily from these efforts so as not to overtire him.

This concerned the observation channel in the copying system. The operation channel required that the operator with his hands on the master device is kinematically the same as the manipulator, and perform all the required complicated and large movements. Therefore, a semiautomatic system was developed with a control lever that would operate in any direction by the simple pressure of the operator's hand. Signals from the lever enter a special computer which would produce corresponding control signals and direct them to the working manipulator. Serious ergonomic investigations were required to make the lever convenient to operate and insure that the general organization of the system produced the most effective action.

The following step was to robotize this system, i.e., create (for separate parts of the general operation) automatic actions according to a given program, to free the man from manual work on the master device. However, control of some part of the total operation, did not lend itself to automation, remained remotely controlled manually (copying or semiautomatic). In this case, the basic ergonomic problem consisted of an optimal determination of a system of the degree of the automation and the share of manual control in each specific application of such a combination man-machine system. This has economic importance.

Finally, in using an adaptive robot with elements of artificial intelligence by computers, a dialogue (interactive) is organized between a human operator remotely, controlling a robot in an enclosed chamber. Here is a specific level of ergonomic investigations. Such a system has still not been realized.

It must be said that robots and manipulators remotely controlled by a human operator are being used more and more under production conditions in all industrially developed countries in the world, even in the ordinary production shops. However, this problem is especially acute in the coal, construction and lumber industries and several others. In its solution, jointly with representatives of corresponding department organizations, are engaged specialists of "Robototekhnika" Scientific Training Center of the USSR Academy of Sciences and the USSR Minvuz. To obtain an economic effect and high productivity of such systems, it is necessary to solve a number of ergonomic problems related to the interaction between a human operator and the robot. However, in doing this work, we encountered a number of difficulties, especially, a shortage of specialized equipment for ergonomic investigations. It is necessary to solve this problem with the help of the corresponding subdivision of the State Committee of the USSR Council of Ministers on Science and Technology.

COPYRIGHT: "Tekhnicheskaya estetika", 1986

2291

CSO: 1823/188

ROBOTICS

PRICES OF ROBOTS, ACTUAL COST IN PLANTS REVIEWED

Moscow EKONOMICHESKAYA GAZETA in Russian No 14, Mar 86 p 17

[Unattributed article: "Robots and Prices"]

[Text] The USSR Goskomsen [State Committee on Prices] reviewed the results of checking the correctness of setting and applying prices for NC automatic manipulators (industrial robots). Enterprises of the Ministry of the Automotive Industry, Ministry of Instrument Making, Automation Equipment and Control Systems, Ministry of Machine Tool and Tool Industry, Ministry of the Electrical Equipment Industry and Ministry of the Chemical Industry where about half the total output of this product is used, were checked. At the same time, a check was made of the actual economic effect of using this equipment at a number of enterprises which use robots.

In the course of the discussion it was noted that single industrial robots that are manufactured in series on orders (including robots to be used only for intraministry purposes) must be approved by the USSR Goskomsen. However, ministries and their enterprises set prices independently for this product, as well as adding incentive additions at times on the basis of premeditated inflated costs.

According to the results of the checks the USSR Goskomsen canceled the economically unsubstantiated prices for a number of industrial robots and approved prices for them in the established order, and removed from their budget the illegal receipts which were obtained by three enterprises for a total of 456,400 rubles by violating the state price.

Checks showed that only in three out of ten cases was there a reduction in the cost of production by using robots in technological processes in manufacturing. Moreover, only in two cases did the actual economic effect exceed the rated one assumed in approving the wholesale price and the incentive bonus.

In practically none of the checked consumer plants was an objective calculation made of the economic effect -- not at the introductory stage, nor actually. In domestic enterprises, as a rule, data is shown on conditional freeing of workers and conditional savings which, as shown by the check, did not correspond to the actual conditions.

For example, the Moscow Jewelry Plant claimed an annual saving of 10,200 rubles by introducing 44 PRP5-2P robots on one of the lines. Actually, the use of these robots results in an annual loss of 68,600 rubles. The loading coefficient of the robots here is only 0.1. It was found that by raising this coefficient to 0.8 this line would need only 12 robots instead of 44.

At the Mytishchinskiy Experimental Plant of the RSFSR Ministry of Automobile Transport and the Moscow Plant imeni Vladimir Ilich of the Ministry of the Electrical Equipment Industry purchased robots are not used in general because they are not called for in existing equipment.

The decision adopted by the USSR Goskomtsen points out the fact that it is necessary to increase responsibility in considering costs for the production of industrial robots and expand work on checking the actual economic effect of using the most important kinds of the latest equipment.

2291

GSO: 1823/188

ROBOTICS

ROBOT USE VIEWED

Minsk NARODNOYE KHOZYAYSTVO BELORUSSII in Russian No 3, March 86 p 2

[Unattributed article: "Robots Do the Pressing"]

[Text] Robots replaced press workers at the consumer goods section of the Minsk Bearings Plant. A special design closed-die forging line began operating here that fully automated the production of one of the most labor-intensive and complicated parts -- the overrunning clutch of a children's bicycle. With this device, the small machine acquires the running qualities of a machine made for an adult. Creators of the line, specialists in the shop for their own machine tool building, insured the work of the equipment according to the most efficient program: its raw materials are the metal scrap of the enterprise.

Good equipment, besides the automatic machines in the wide-consumption section, multiposition machine tools were also installed which made it possible for the production workers to utilize the metal scrap fully. Last year alone products to an amount of 760,000 rubles were made from scrap.

The quality and assortment of goods were noticeably renovated. The output of such scarce articles as scissors and sets of woodworking tools was mastered, and preparations are being made for series production of vegetable slicers.

2291
CSO: 1823/213

ROBOTICS

BRIEFS

ROBOTS IN KIROVAKAN -- A plant is being built in Kirovakan to manufacture special technological robot equipment. It is planned to place the first stage of the enterprise in operation in the fourth quarter of this year. Komsomol-youth shock worker brigades at the construction site fulfill their tasks by 120 to 130 percent. The enterprise is a high priority construction site in the republic. It will supply advanced equipment to many instrument-making plants of the republic. Actually, a sector is being born in Armenia which is being called upon to insure scientific technological progress at accelerated rates. [Unknown author] [Text] [Tbilisi MOLODEZH GRUZII in Russian 25 Mar 86 p 2] 2291

ROBOT FOR 'ZHIGULI' -- At the "Robots and Robot-Technological" Exhibit it is possible to see the latest model VAZ-2108 "Zhiguli" automobile. Beside it is a welding robot-complex. Visitors can see a demonstration of the operation of the manipulator which having clamped heavy welding pincers in his powerful "arm" brings them easily to the body of the car. Short flashes of the electrical welding follow one another... It takes just over a minute for the robot to weld at 48 points, while almost 5000 welds are required in building the body. This is one of the most labor-intensive production operations which previously was done at this plant manually. After introducing and mastering such robot complexes, it will require only two hours to weld the body or much less than before. Welding is not the only specialty of the robot. It can also be used successfully in assembly operations, for example, to install wheels. [Author unknown] [Text] [Riga SOVETSKAYA LATVIYA in Russian 13 Feb 86 p 2] 2291

ROBOTS EXHIBITED -- Tallin -- One of the Estonian SSR VDNKh pavilions exhibited a plant shop of the future in which all operations are performed by robots. Yesterday an exhibition "Robots and Robot-Technology in the National Economy" was opened here to visitors showing the achievements of domestic sciences and technology in the area of automation of production. On its basis a scientific-practical seminar was held which convened many robot equipment specialists from Moscow, Latvia and Estonia. [Author unknown] [Text] [Moscow SELSKAYA ZHIZN in Russian 23 Mar 86 p 1] 2291