

102077

JPRS-UMM-85-005

11 March 1985

USSR Report

MACHINE TOOLS AND METALWORKING EQUIPMENT

Reproduced From
Best Available Copy

FBIS

FOREIGN BROADCAST INFORMATION SERVICE

REPRODUCED BY
NATIONAL TECHNICAL
INFORMATION SERVICE
U.S. DEPARTMENT OF COMMERCE
SPRINGFIELD, VA. 22161

19981118 170

NOTE

JPRS publications contain information primarily from foreign newspapers, periodicals and books, but also from news agency transmissions and broadcasts. Materials from foreign-language sources are translated; those from English-language sources are transcribed or reprinted, with the original phrasing and other characteristics retained.

Headlines, editorial reports, and material enclosed in brackets [] are supplied by JPRS. Processing indicators such as [Text] or [Excerpt] in the first line of each item, or following the last line of a brief, indicate how the original information was processed. Where no processing indicator is given, the information was summarized or extracted.

Unfamiliar names rendered phonetically or transliterated are enclosed in parentheses. Words or names preceded by a question mark and enclosed in parentheses were not clear in the original but have been supplied as appropriate in context. Other unattributed parenthetical notes within the body of an item originate with the source. Times within items are as given by source.

The contents of this publication in no way represent the policies, views or attitudes of the U.S. Government.

PROCUREMENT OF PUBLICATIONS

JPRS publications may be ordered from the National Technical Information Service (NTIS), Springfield, Virginia 22161. In ordering, it is recommended that the JPRS number, title, date and author, if applicable, of publication be cited.

Current JPRS publications are announced in Government Reports Announcements issued semimonthly by the NTIS, and are listed in the Monthly Catalog of U.S. Government Publications issued by the Superintendent of Documents, U.S. Government Printing Office, Washington, D.C. 20402.

Correspondence pertaining to matters other than procurement may be addressed to Joint Publications Research Service, 1000 North Glebe Road, Arlington, Virginia 22201.

Soviet books and journal articles displaying a copyright notice are reproduced and sold by NTIS with permission of the copyright agency of the Soviet Union. Permission for further reproduction must be obtained from copyright owner.

NOTICE

A new serial entitled WORLDWIDE REPORT: ARMS CONTROL will be published starting in March 1985.

The new report will contain Soviet, European, and other foreign media reportage and commentary on arms control issues, negotiations, agreements, and treaties. Much of the material will be reprinted from the regional FBIS DAILY REPORTS.

U.S. Government consumers may arrange to receive the new report through regular publications distribution channels or by contacting:

FBIS/Liaison and Requirements
P.O. Box 2604
Washington, D.C. 20013

Other consumers may order the report by contacting:

National Technical Information Service
5285 Port Royal Road
Springfield, VA 22161

11 March 1985

USSR REPORT
MACHINE TOOLS AND METALWORKING EQUIPMENT

CONTENTS

OTHER METALWORKING EQUIPMENT

Advances in Cutting Tool Technology Surveyed (MASHINOSTROITEL', No 8, Aug 84)	1
Composite Metal Inserts, by V. P. Zhod' Diamond Cutters Grinders, by B. F. Romanov	
Developments in Forge-Press Automation Viewed (V. V. Karzhan; KUZNECHNO-SHTAMPOVOCHNOYE PROIZVODSTVO, No 5, May 84)	13
Advanced Rolling Mill Technology on Stream (EKONOMICHESKAYA GAZETA, No 40, Oct 84)	23
Development of Hydraulic Forge-Presses Viewed (V. V. Karzhan; KUZNECHNO-SHTAMPOVOCHNOYE PROIZVODSTVO, No 5, May 84)	24
Plasma Cutting Technology Implemented (M. Malkin; PRAVDA, 6 Sep 84)	27
New Tooling for Plasma Cutting Technology (M. T. Korotkikh; MASHINOSTROITEL', No 8, Aug 84)	28
Advanced Machine Tools Developed at Orsha Plant (A. Miloserdnyy; SOVETSKAYA BELORUSSIYA, No 6, Jun 84) ..	31
Design Features of New Broaching Machines Reviewed (G. Bulankov; PROMYSHLENNOST' BELORUSSII, No 2, Feb 84) .	34
Briefs	
Vacuum Spraying	36
Impact-Stamping	36

AUTOMATED LINES AND AGGREGATED MACHINING SYSTEMS

Versatility of Forge-Press Machining Centers Viewed
(I. Z. Mansurov, Yu. S. Radyuchenko; KUZNECHNO-
SHTAMPOVOCHNOYE PROIZVODSTVO, No 5, May 84) 37

OTHER METALWORKING EQUIPMENT

ADVANCES IN CUTTING TOOL TECHNOLOGY SURVEYED

Composite Metal Inserts

Moscow MASHINOSTROITEL' in Russian No 8, Aug 84 pp 9-11

[Article by V. P. Zhod', director of VNIInstrumenty "High Productivity Cutting Tool"]

[Text] Scientific technical progress in machinebuilding has increased sharply in its level of automation and the intensification of the production processes due to the wide use of automatic metalcutting equipment, as well as to the increase in the share of materials difficult to machine that have special physiomechanical properties. An important role in accelerating technical progress in machinebuilding is being played by the metal-cutting tool that makes it possible to organize the production of products with minimum expenditures of social labor.

In creating a highly productive cutting tool, it is necessary to take into account the increase in its technical standards which would make it possible to intensify machining modes and utilize fully the possibilities of automatic equipment, which must be achieved by saving or replacing tool materials by a material that is capable not only of preserving, but increasing the productivity of machining.

The creation of a progressive cutting tool is proceeding along several basic directions. One is the development of a tool with a mechanical attachment of multifaceted plates, made of various tool materials whose use will increase the cutting speed up to 1.5-fold. In particular, cutters with multifaceted plates of a hard alloy increase the productivity of labor by 20 to 22 percent as compared to brazed cutters while a tool with plates made of hard alloy with wear-resistant coating -- by up to 40 percent (the use of plates with wear-resistant coating practically eliminated the brazed tool).

One considerable reserve for increasing the productivity of machining parts by cutting is by expanding the use of tools made of polycrystalline superhard materials based on cubic and wurtzite-like boron nitride. This qualitatively new group of tool materials whose optimal application conditions are characterized by the following: high cutting speeds and thin chips; high cutting capacity and comparatively low unit power consumption; low cutting forces and machining

accuracy; fairly considerable heat release in the cutting zone; less roughness of the machined surface and high quality of the thin surface layer of the part; higher demands on the equipment and on the entire technological process of manufacturing the part as a whole.

The great efficiency in using tools equipped with polycrystals of composite 01 (el'bor-CO, composite 05, composite 10 (hexanite-R) and composite 10D (double-layer plates with a working layer of hexanite-R), is due to the unique combination of their physio-chemical characteristics: great hardness (4000-7500 kg-force/mm²), i.e., 2 to 4-fold of that in hard alloys; great heat-resistance (1100-1300°C); good heat conductivity (42-50w/mK), close to the heat conductivity of hard alloys and does not reduce when the temperature is increased; chemical inertness to compounds of iron and carbon; self-sharpening of cutting edge (rounding off the radius of the edge does not exceed 25-40 micrometers along the period of tool stability and is practically independent of cutting modes); fair viscosity.

Recently, composite tools came into wide use in domestic industry; especially in machine tool building, automobile and agricultural machinebuilding. It is used for preliminary and finish machining of parts made of cast iron, hardened steels, hard and difficult to machine alloys instead of traditional hard alloy and mineral-ceramic tools, as well as instead of abrasive wheels in grinding. This is due to the fact that the introduction of composite tools makes it possible to concentrate operations, improve or fully change machining technology and reduce to a half or a tenth the basic machining time of the part; simplify the technological cycle by eliminating or shortening some operations; improve the quality of the machined surface (eliminate microfissures, burns, tensile stresses, distortions); free workers, equipment and production areas. It should be noted that the efficient operation of a tool equipped with composite plates requires high precision and high productivity machine tools. We will use such tools primarily in NC machine tools and automatic lines.

Tools with wear-resistant coatings are distinguished by a high technical standard and a longer service life. A technology was developed in the institute for applying wear-resistant coatings to tools made of high speed cutting steel tools. The service life of such tools increases 2 to 3-fold which makes it possible to operate at higher cutting modes. For example, the use of a hobbing cutter with a wear-resistant coating at the "Krasnyy proletariy" plants imeni A. I. Yefremov and imeni S. Ordzhonikidze made it possible to increase the productivity of labor in gear cutting by 25 percent. Tool plants organized the technology of applying wear-resistant coatings of titanium nitride on such high speed steel tools as drills with ground helical channels, taps, hobbing cutters, gear shapers and broaches. The output of such tools in 1984 as compared to 1983 must increase 2.5-fold and 4-fold in 1985. More productive installations (for example, NNV-6.611 installations) are being used to apply wear-resistant coatings. A technology is being developed for applying multilayer wear-resistant coatings on tools made of high speed steel.

The productivity of cutting increases essentially when the cutting tools are equipped with mineral-ceramic plates. Such cutters are used in semifinish and finish grinding of parts made of gray, malleable high-strength and chilled cast iron at cutting speeds of up to 400 to 500 meters/min. For example, at the Leningrad Machine Tool Building Association imeni Ya. M. Sverdlov, when changing the internal and external grinding of tools by grinding with cutters, equipped with mineral-ceramic VOK-60 brand plates, the man-hours per job were reduced to 1/1.6, and at the Ul'yanovsk Heavy Special Design Machine Tool Plant, the productivity increased 2.5-fold in grinding sleeves. It should be noted that the cutting process by a tool equipped with mineral-ceramic plates proceeds stably on fairly rigid equipment. The cutting speeds, depending upon the machined material and machining conditions, reaches 300 to 500 meters/min, with a cutting depth of up to 3mm and a feed of 0.06 to 0.63mm/revolution.

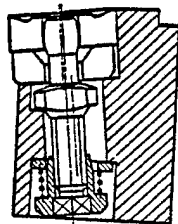

Fig. 1

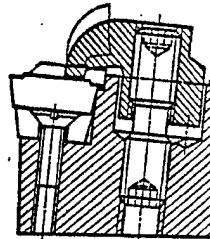

Fig. 2

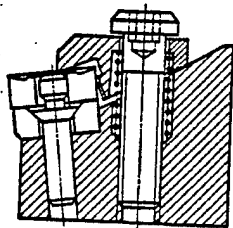

Fig. 3.

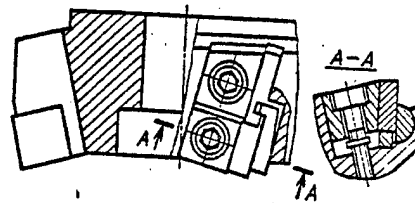

Fig. 4

In manufacturing large size tools, for example, high modulus hobbing cutters, it is most efficient to use high speed powder cutting steel. The basic advantage of such steels is obtaining low carbide nonuniformity.

In the current five-year plan period, it is proposed to expand the nomenclature of the cutting tools by almost 25 percent basically due to the use of new designs as follows:

change the structure of tool materials (increase the number of high alloy tools, basically built-up with the mechanical attachment of plates and the tool, equipped with plates from hard alloys without tungsten, mineral-ceramics and superhard syntehc materials;

increase efficiency in utilizing automatic metal-cutting equipment by using tools meeting requirements of automatic production: high precision, service life, reliability and rapid changeability.

expand sharply the nomenclature of high productivity tools: the share of type-sizes of tools with mechanical securing of plates in the total output volume of hard alloy tools will almost double (1980--812 type-sizes, 1985--1450 type-sizes), tools of high speed steel with wear-resistant coatings will increase to 6000 type-sizes and hard alloy tools with plates of hard alloys with wear-resistant coatings will increase to about a 1000 type-sizes;

expand the nomenclature of precision tools (from 2450 type-sizes in 1980 to 3000 type-sizes in 1985);

create and expand the production of new in principle tool designs.

To solve the posed problems, the VNIInstrument did a large volume of scientific research and organization work, whose introduction affects directly the increase in labor productivity and the reduction in man-hours in metalworking.

A standardized system was developed for designs for turning sectional tools with mechanical securing of mansided plates made of hard alloys, including wear-resistant coatings, hard alloys without tungsten, ceramics and plates of other tool materials. Plate dimensions are in accordance with ISO [International Organization for Standardization] and SEV standards. The basis of the system is the standardization of methods for securing the plates as well as the dimensions of their shapes.

The cutters of the first group specify securing plates without holes of trihedral or square shape, with or without rear angles, in an enclosed slot with a clamp on top. The positioning of the cutting plate in the seat of the cutter housing makes it possible to replace it with a new one when necessary without adjusting the cutter for size. Such a tool operates under various conditions in universal and in NC machine tools. The first group has 204 type-sizes of cutters.

Cutters of the second group (Fig. 2) use trihedral, square, rhombic, circular and other shape plates with a hole. The plates are secured by a rocking pin. Such cutters are used for machining open, stepped, conical, cylindrical and face surfaces of solids of revolution type parts in chuck, chuck-centering machine tools and automatic machines, as well as in NC machine tools. There are 127 type-sizes in the second group.

Many machinebuilding sectors standardized the design of the cutters securing plates with an L-shaped lever.

Cutters of the third group (Fig. 3) have plates of square and hexahedral shapes with a tetrahedral or hexahedral hole with an 80° angle at the point and are secured by a "clamp-wedge." They are used for semifinish and finish machining. They will replace brazed design cutters and cutters manufactured according to GOST21151-75. They are being used efficiently in contour grinding on universal equipment. The third group of cutters includes 46 type-sizes.

The considered cutters have holders with a cross section of 16 to 50mm with connecting cross sections which meet the requirements of SEV and ISO. The cutters come in sets of 50 reserve plates. The average capacity of cutter housings is 100 plates.

The institute is doing work on creating designs of assembled cut-off and slotted cutters, equipped with hard alloy plates instead of brazed ones. Experience in operating brazed cutters indicates that about 50 percent of them fail before their rated period due to the shearing or breaking of the cutting edges. This leads to frequent replacement of the broken tool by a new one and increases the time and cost of machining. Such cutters, unlike the brazed ones, have higher rigidity and strength of the working part due to an increase in the auxiliary angles in the plane and of side rear angles, and have better operating conditions.

Mechanical securing of multisided plates is also used for the assembled face cutters. But such milling cutters may be used basically on average power (10 to 12kw) machine tools which makes it impossible to utilize fully the capabilities of hard alloy plates. Moreover, the design of such milling cutters eliminates the possibility of using multisided plates made of mineral ceramics and hard alloys without tungsten that require greater rigidity of fastening in order to insure vibrationless operation.

The institute developed a series of standardized designs of assembled face milling cutters 100 to 500mm in diameter equipped with multisided plates of hard alloys with and without tungsten, and of mineral ceramics (Fig. 4). Depending upon the geometrical parameters and their purpose, the milling cutters are equipped with trihedral and tetrahedral plates 12.7 and 15.8mm in the diameters of the inscribed circumference. Precise plates with a trimming edge are used for finish operations. The precision of the shape-forming edges of plates is possible by regulating the spacers under the plate.

Most promising is a tool with mechanical securing of round and mansided plates of composites, whose production is being increased intensively by the machine tool and tool industry. If the design with mechanical fastening of plates is technically impossible (due to the type of the tool, its dimensions, geometry, etc.), it is recommended that a regrindable brazed tool made of composite material be used, for example, boring cutters for machining holes 6 to 30mm in diameter

At present, production has been organized of a series of cutting plates made from various brands and shape-sizes of composite materials, including one-piece and double layer (with a substrate from structural material). These plates were at the basis when a series of turning cutters was developed.

The basic directions in designing facing millcutters from composite materials are determined by technological problems which must be solved efficiently in applying them. Assembled facing cutters 80 to 200mm in diameter have been created with adjustable inserted blades, equipped with polycrystalline composites 01 or 10 (Fig. 5). The end play is regulated within 0.01mm. To reduce the roughness of the machined surface at higher feeds, the tool points are made

with a large radius (20 to 50mm). An efficient area of application for this tool is finish machining on longitudinal and flat grinding machine tools, as well as NC machine tools and processing centers, in place of preliminary and final grinding; and partially in place of scraping. The depth of cut is not greater than 0.5mm with longitudinal feeds of 5 to 10 meters/min (a large radius at the blade point provides normal operation with high feeds on grinding machine tools). The roughness of the machined surface is $Ra = 0.4 \dots 2.5$ micrometers.



Fig. 5

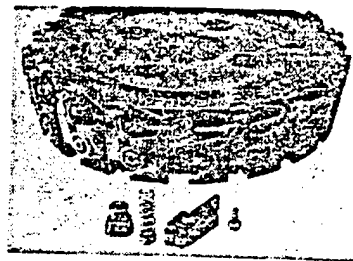

Fig. 6

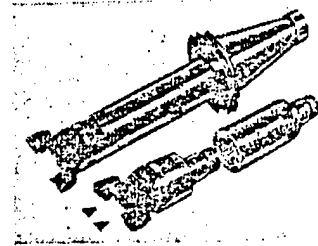

Fig. 7

Assembled facing milling cutters 100 to 500mm in diameter with the mechanical attachment of high precision round plates, made of composites 01.05 and 100 (Fig. 6), were developed for preliminary and finish machining of parts to replace hard alloy cutters. These milling cutters were made with unregulated or regulated play within 0.01mm, in the single row or stepped types. Such cutters can be used efficiently in milling automatic and semiautomatic machines, in NC machine tools and processing centers, plano-milling, horizontal-boring, coordinate boring and universal and vertical-milling machine tools. The cutting depth is up to 2mm in steel and up to 6mm in cast iron; longitudinal feed is up to 3.0 meter/min; surface roughness is $Ra = 1.0 \dots 5.0$ micrometers.

A considerable volume of work was done by the institute to create cutting and auxiliary tools to equip NC machine tools. The auxiliary tool which is called upon to insure the reliable and rigid attachment of the cutting tool and its interchangeability and adjustability to dimension, must be especially precise. In this connection, the institute developed a system for a boring tool for drilling-boring and milling NC machine tools, including the processing center type. This tool is designed with a minimum of four components: a tail end, a replaceable cutting head, depending upon the kind of machining (boring, drilling, milling, threading), and two intermediate components -- extender and adapter. Two-teeth and single tooth adjustable heads (Fig. 7) have been designed on that basis for rough, semifinish and finish boring of holes 40 to 160mm in diameter, equipped with multiface nonregrindable plates of a trihedral shape with given angles, including a wear-resistant coating.

The introduction of the new boring tool system makes it possible to reduce the number and types of fixtures required to operate the machine tools and eliminates the manufacture of a new tool. Preparation for production time is reduced when changing over to a new machined part, especially when there are various types of machine tools in production with several type-sizes of spindle seats.

The institute's work directed toward creating cutting tools of glued design and the development of a technology to obtain glued connections is promising. The technological and economic expediency of using gluing in manufacturing tools is determined by the following:

preservation of the hardness of the tool, previously thermally treated, which will raise its operating properties;

reduction of internal stresses in cutting components, whose appearance in brazing and welding leads frequently to the formation of microfissures and the destruction of the integrity of the cutting components;

increase in the service life of the tool by preserving the initial properties of the cutting components and due to the damping property of the glued seam and rigidity of the glued connection;

save 50 to 60 percent of tool materials when changing from integral to glued design;

possibility of using cutting components with wear-resistant coatings;

possibility of multiple utilization of thermally treated tool frames and full utilization of worn cutting components.

The institute developed a compound hobbing cutter of glued design (with an 0.3 to 18mm modulus), equipped with cutting elements made of a hard alloy (low moduli) and high speed steel, as well as a broach with cutting components glued in for machining key-grooves 12 to 50mm wide.

The same basic trends are being kept in creating a progressive tool for the next five-year plan period also;

creation of new designs of cutting and auxiliary tools for new generations of NC machine tools, including those operating in flexible production systems and automatic complexes;

development and organization of production cutting tools with multilayer and composite wear-resistant coatings, whose service life will be more than 4-fold that of those without wear-resistant coatings;

further expansion of the nomenclature of the assembled tool with the mechanical attachment of plates made of hard tungsten alloy, hard alloy without tungsten and mineral ceramics;

creation of a tool equipped with new superhard tool materials.

COPYRIGHT: Izdatel'stvo "Mashinostroyeniye", "Mashinostroitel'", 1984

Diamond Cutters Grinders

Moscow MASHINOSTROITEL' in Russian No 8, Aug 84 pp 10-11

[Article by B. F. Romanov, winner of USSR State Prize, director of VNIIalmaz: "Development of Diamond Cutting and Grinding Technology"]

[Text] Diamond machining is a promising technological process. The volumes of use of industrial diamonds increase constantly. The development of diamond tool designs is determined to a considerable degree by the development of the technology for the synthesis of artificial diamonds (the use of diamonds is being expanded basically by utilizing synthetic diamonds and other super-hard materials). The technology of synthesizing artificial diamonds involves the production of mono and polycrystalline diamonds and composition diamond-containing materials.

Domestic industry has organized the production of the indicated types of diamonds. Thus, high strength and thermally stable monocrystalline diamonds brands AS50-AS80 in a size of up to 800 micrometers, as well as polycrystalline diamonds: black diamonds, ballas and SV [Synthetic Fiber] in a size up to 10mm, have been manufactured. Production of single-layer and double-layer diamond plates used in cutting tools is being organized. This raw materials base with the constant decrease in the use of natural diamonds is the basis for the development of the manufacture of a wide array of (at present there are up to 5000 items) of diamond tools.

At the same time, new areas of applications are opening up for tools using natural diamonds, such as diamond cutters for turning high-precision parts, straightening tools, hardness gages, etc. Thus, diamond cutters with natural diamonds are used to grind surfaces which have exceptionally high requirements with respect to the reflecting capacity and roughness. The surface machined with such diamond tools oxidizes more slowly and has a higher destruction threshold than a polished surface. Diamond crystals used for such cutters are selected by a method developed by the VNIIalmaz.

There are special requirements for monitoring the cutting edges. For example, for precision cutting the edges are checked with a 250 to 500 magnification (usual tools are checked with an 85 magnification). Specifically, such cutters are used to machine memory disks for computers, metal optics screens, etc. The special feature of such cutters is the presence of a rounding along the large radius of the edge or the section of the edge with $\varphi = 0$.

The achieved machining precision and roughness are shown in the Table.

Table

Part	Material	Quality of machined surface		Cutting modes		
		Roughness, Ra, micron	Precision of shape along 100mm	t micron	s, micron per min.	v meter per min.
Computer disk	Aluminum alloy	0.05	0.5	10	50	2300
Metal optics parts:						
flat surface	Copper	0.02-0.025	0.3	3	5	2500
spherical surface	Copper	0.02	0.2	2	5	3100
Precision Internal cones	Aluminum alloy	0.05	0.5	10	20	500

In recent years, cutters made of synthetic polycrystalline diamonds of the carbonado [Black diamonds] or SV types, as well as of composition materials are used for diamond turning (dressing, boring and machining surfaces). The design of a turning cutter is shown in Fig. 1.

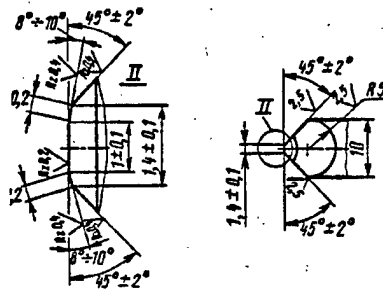

Fig. 1

By using such cutters, a surface roughness within $Ra = 0.6 \dots 0.16$ micrometers is obtained, as well as a machining precision (for example, in boring 32 to 50mm diameter holes) of within 0.005 to 0.01mm, out-of-round and angle of taper within 0.005mm.

For decorative machining (surface roughness not greater than $Ra = 0.32$ micrometers) the use of cutters from polycrystalline diamonds type AKM (diamond composition material) and SKM (sintered composition material) is recommended. The advantages of such diamonds are their large sizes (up to 8-10mm) and small structure, making it possible to shape a "smooth" cutter edge. Such tools may be used to machine radio and camera parts, a number of jewelry articles, etc. They produce a decorative luster, and have a fairly high service life (up to 50 percent of service life of cutters from natural diamonds).

Diamond straightening remains the basic and practically single method for restoring the cutting capability and precision of grinding wheels. Of greater importance is trueing with diamond shaped rollers, whose wide use will make it possible, in many cases, to revise the technology of grinding operations with an increase in the productivity of labor. For example, the application of wasteless technology, is being expanded which is implemented, as is well known by in-feed grinding in multitool grinding machine tools. In mass production, it became possible to combine the grinding of surfaces which were previously machined in several stages and sometimes were turned or milled. Thus, in automobile production crankpins, valves, bolts, splines, stepped shafts, etc. are now changed over to machining by grinding. Diamond rollers are used to machine about 600 various kinds of shaped parts.

The basic dimensions of the machined parts are: length 400mm (roller unit); largest difference in diameter dimensions 80mm; smallest thickness of protruding parts 2mm; smallest rounding radii ≥ 0.2 mm; smallest pitch of ground thread 1mm; largest length of ground part of thread 30mm for 1mm pitch, 50mm for pitch ≤ 1.5 mm; 75mm for pitch ≤ 3 mm and 100mm for pitch ≤ 6 mm. Machining precision of parts: linear surfaces ± 0.01 mm; angular dimensions $\pm 8'$. Roughness of machined surface $Ra = 0.63$ micrometers. It is most advisable to use shaped diamond rollers with combined grinding of several surfaces and in depth grinding by the in-feed grinding method. Shaped diamond bars are used basically on surface grinder machine tools.

Especially processed natural diamonds are used basically for manufacturing diamond rollers which, in a number of cases, doubles the service life of the rollers. A technology was developed for restoring diamond rollers that increases their service life 1.5 to 2-fold.

Experimental work is being done on replacing natural diamonds by synthetic ones. Thus, since 1980 straight rollers have been made of synthetic diamonds used to grind crankpins and main journals of crankshafts. A technology of synthesizing strong monocrystalline diamonds for manufacturing diamond rollers is being completed.

Other trueing tools are also being modernized. For example, instead of expensive trueing tools, diamond cutters, a diamond comb (Fig. 2), consisting of two and three square cross section pegs, sintered into a holder by powder metallurgy, is used. In trueing, the worn area is always equal to the cross section of the diamond pegs. The advantages of using the diamond combs are; constant trueing conditions; a reduction in the amount of diamonds used and, therefore, a reduction in cost as compared to diamond cutters. The diamond combs can practically fully replace the diamond cutters in all operations, except when there are limitations in the configuration of the machined part.

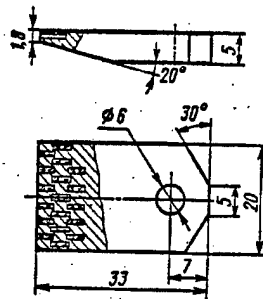

Fig. 2

One traditional direction in diamond machining is grinding multiface hard alloy plates. The diamond wheels (over 20 type-sizes) operate, as a rule, in the depth grinding mode ($s_p = 0.1 \text{ mm/double stroke}$). A new type of the diamond wheels, whose production was organized in industry, are two-layer wheels with two concentrically located diamond-bearing layers. The outer layer contains larger-grain diamond powders (AS6 160/125) than the inner layer (AS6 50/40). When such wheels are used, 7 to 10 plates are ground simultaneously with the allowance removed in one pass, with an 0.2mm depth of grinding and a longitudinal feed of 80 to 150mm/min. The grinding productivity of a hard alloy reaches $1200 \text{ mm}^3/\text{min}$ with a surface roughness $R_a = 0.16$ micrometers. The unit consumption of the diamond is 0.4mg/g. The service life of one diamond wheel is about 50,000 plates.

In sharpening cutting tools made of superhard polycrystalline materials based on cubic boron nitrides (01, 05, 10 brands of composites) diamond wheels with IM-1 polyimide tar binders are used. The wear resistance of such wheels is 3 to 4-fold greater than diamond wheels with B1, and T02 binders. They practically eliminate splits and burns on the machined surfaces.

Wheels with polyimide binders are electrically conductive and can operate in the electrical diamond grinding mode.

With a grain size of 125/100 micrometers and greater, the diamond wheels can be operated without cooling for transverse feeds of up to 0.06mm/double stroke. For greater feeds, chemically active lubricating-cooling liquids may be used, since type IM1 binders have higher resistance to chemical action. Surface roughness when using wheels with grain size of 80/65 to 100/125 micrometers is similar to using wheels with a grain size of 80/63 micrometers with binders. Optimal grinding modes with IM1 binders are $s_t = 0.08 \dots$ 0.1mm/double stroke in the transverse direction and $s_l = 1 \dots 2$ meters/min in the longitudinal direction.

Comparatively new are diamond wheels for depth grinding of channels in a hard alloy end cutter 3 to 12mm in diameter. The grinding is done in one pass at the entire depth of the channel. Thus, with a drill diameter of 6.2mm the grinding depth is 2.1mm, while for a diameter of 12mm -- the depth is 4.2mm; the roughness is $R_a = 0.32 \dots 0.63$ micrometers.

Diamond honing has been developed successfully in recent years, for example, flat-top honing of cylinders for automobile and tractor engines, which forms a microrelief on the surface of the cylinder with alternating "plateaus" and grooves. At first, the diamond bar produces a certain flat-vertical shape on the surface, which is then machined by special antifriction bars. The compositions of the bars and the honing modes are determined so that there is adhesion between the antifriction bar and the machined surface in the process of machining. The antifriction substances are retained reliably on the working surface of the cylinder in the recesses of the grooves and on the "plateau."

Bench tests of engines, in which cylinders machined by this method are installed, indicate that their wear in the operating zone of compression rings decreased by 30 to 50 percent and oil losses were reduced by 20 to 30 percent. At the same time, the running-in cycle time of the engines was shortened and anticuff properties were improved. Oil consumption, as a whole, decreased by 0.6 percent and fuel consumption by 1 to 2 percent. The motor capacity of the engines increased from 6000 to 7000 hours. The new technology is being used widely at many tractor and automobile plants.

COPYRIGHT: Izdatel'stvo "Mashinostroyeniye", "Mashinostroitel", 1984

2291
CSO: 1823/71

OTHER METALWORKING EQUIPMENT

UDC 621.73-65.011.56.001

DEVELOPMENTS IN FORGE-PRESS AUTOMATION VIEWED

Moscow KUZNECHNO-SHTAMPOVOCHNOYE PROIZVODSTVO in Russian No 5, May 84 pp 9-12

[Article by V. V. Karzhan, director of ENIKmash: "Ways and Perspectives of Technological Process in Automation Development in Forge-Press Production"]

[Text] At the June (1983) Plenum of the CPSU Central Committee it was stressed that "...Production must be automated, computers and robots must be used widely and flexible technology, that makes possible rapid and efficient readjustment of production for manufacturing new products must be introduced."

In the light of these requirements, automation becomes an important technical, economic and social problem, and the main means of intensifying all areas of social activity, whose necessity and expediency become especially urgent in forge-press production (KShP) where the scarcity of manpower due to hard, tiring and frequently harmful and dangerous conditions, is felt acutely.

An analysis indicates that manual servicing in machinebuilding enterprises results in a low utilization coefficient of forge-press machines [1].

The basic time in manufacturing semifinished or finished parts (the machine time of high speed KPO [Forge-Press Equipment] occupies an insignificant part of 5 to 10 percent) is spent on auxiliary operations such as: loading-unloading, transportation between operations, packing, changing dies and tools, etc. [2]. Thus, automating auxiliary operations that would preserve the stability of the quality and properties of the manufactured products, is the basic source of increasing the productivity of labor in forge-press production.

The selection of one or another automation level in part or in the comprehensive automation of auxiliary operations depends, in each specific case, on the conditions of production. It should be kept in mind that KShP automation, is more efficient in flow-line operations, and when it is based on progressive operational and metal-saving technological processes.

Taking into account the fact that automation as a basic direction in intensifying production has been the goal of eliminating various operations performed by a stamp operator, we will consider automation levels in KShP.

First, automation level. Control the sequence and nature of operations, performed directly by the forge-press machine itself, for the purpose of obtaining a given shape, dimensions and surface quality of products -- automation of the machining cycle.

For example, NC machines have optimal control of the process for manufacturing parts of a practically unlimited list of products. Such machines include turret and sheet-bending hydraulic presses, sheet-bending two and four-roll, shaping-bending two-roller (Fig. 1), pipe-bending, straightening hydraulic machines, etc. Moreover, this level of automation can also be achieved on KPO without NC, for example, on hot stamping crank presses with automatic transporters and robots, on horizontal-forging machines with special transporters, on forging-roller machines with robots, etc.

Second automation level. Besides the machining cycle, the loading-unloading of intermediate and finished products from the stamping (working) space of the forge-press machine, as well as of its associated equipment are also automated. This is an efficient area of automation which makes it possible for an operator to service several KPO technological units. Among them are automatic and semi-automatic machines and automated equipment complexes for practically all technological conversions by shaping and mechanical working, including cutting, sheet stamping, bending and trueing, closed impression die forging, drop forging, reprocessing plastics and pressing metal powders [3].

Complexes, sections and lines with NC and industrial robot systems have the highest degree of automation, universality and speed of readjustment. These include complexes for cutting sheets into strips using squaring shears with slanting cutting edges (Fig. 2); a section for free forging using a press with a lower location of cylinders (Fig. 3), three and four-operational lines for sheet-stamping using single-crank presses with magazines and interoperational feeders, transfer devices and robots with load-lifting capacities of 1.25, 5 and 10kg.

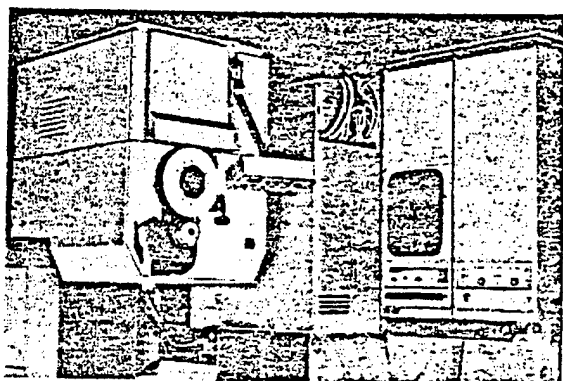

Fig. 1. Model I38435 shaping-bending two-roller NC machine

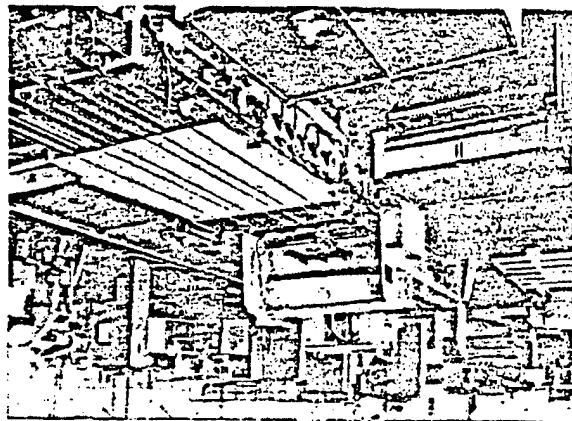

Fig. 2. Model KON1 NC automatic equipment using squaring shears with a slanted cutting edge

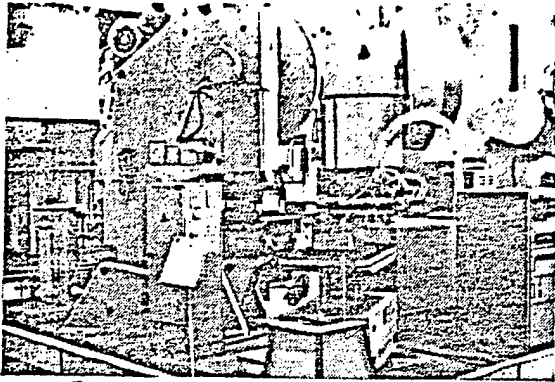

Fig. 3. Technological two-operational section using two single-crank 1000 k newton presses and using model KM5Ts 4202 three-arm robot.

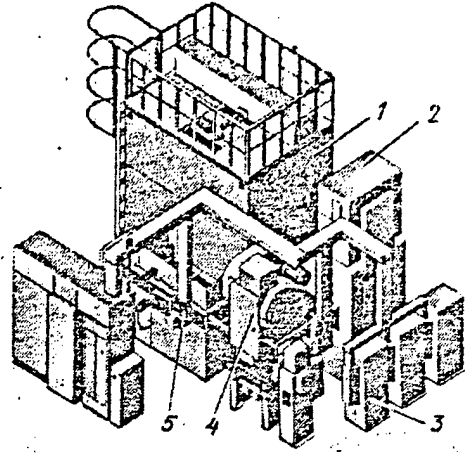

Fig. 4. GP module for stamping parts from strip intermediate products using a single-crank 630 k newton open press.

The third level of automation is the automatic readjustment of equipment. If the readjustment process is not prepared technically, it may take up a considerable part of the total working time. Therefore, the central problem of forge-press production is to improve the readjustment systems for dies, fixtures, tools, etc.

It is necessary to create flexible automatic high productivity production facilities to save labor resources in every possible way. Flexible production is more acceptable for series and small series production; however, series and small series production must be automated so that along with flexibility, they acquire the best features of mass production: continuity, regularity and high rate of output. Automatic flexible production systems of various levels of integration are the commonly-acknowledged new direction of automation [4].

In creating flexible production systems, it is necessary to specialize and concentrate on forge-press production as a premise for mass and large-series production in which automatic machines and lines will be more efficient.

We will consider types of readjustments in KPO operation.

1. Intralot readjustment or changing a worn tool.
2. Interlot readjustment or exchanging one set of tools for another to readjust the machine complex or line for manufacturing a lot of other products. This type of readjustment may be accompanied also by a change in the KPO operating mode and a change in several of its parameters, for example, a change in the

stroke and the number of strokes of the slide blocks, the power of the blow, etc., as well as change and readjustment of components in the interoperation transport, loading and unloading facilities.

3. Intracycle readjustment, consisting of a tool change for the following machining operation.

The first two readjustment types are inherent in all types of production from unit to mass production. However, if the frequency of intralot readjustments depends on the life of the stamping tool, then the number and periodicity of intralot readjustments are determined by the quantity and series production assigned to the equipment.

Intercycle readjustment also concern processing centers where the product machining cycle includes several operations requiring different tools, whose replacement is done by corresponding devices. On other KPO types, readjustments are very labor-consuming and, in a number of cases, are done manually, and this leads to the equipment being idle.

The frequency of interlot readjustments can be evaluated by Table 1 if the size of the lots and the periodicity of their start-up are given.

It was established that the degree of perfection of machining technology on modern KPO depends, to a considerable extent, on the scale of production. Thus, for example, in drop forging, the share of progressive, power and metal-saving processes (shaping intermediate products, various methods of low waste stamping, radial cogging, rolling pinions and sprockets, etc.) for unit, series and large series production are respectively 8, 12 and 80 percent on the average.

Data in Table 2 show that with larger series production, basic technical economic production indicators improve.

It was established (Table 3) that more than half of KPO output (53 to 58 percent) involves unit and series productions in which the greatest quantity of readjustments occurs.

The above stated confirms that mechanization and automation of conversions (flexible productions) reduce idle time, labor-intensity and metal consumption.

The basis of a flexible production system are flexible production modules (GP modules). In the most general form, taking into account what was stated above, terms and definitions of flexible systems for KPO can be formulated as follows.

A flexible production module (GP module) is a unit of technological equipment readjustable for manufacturing a given product list, equipped with NC and devices for loading-unloading and transporting the machined product between conversions, removing waste, changing intermediate products, dies and tools; monitoring the equipment operation, condition of tools and quality of the finished products. It implements multiple automatic working cycles, is designed for independent operation and can be built into a higher ranking system.

Table 1

Production scales in closed die forging and sheet-stamping conversions

Type of products	Size of series, 1000 units/year		
	Unit	Series	Large series
Hot closed die forging			
small forgings	up to 50	50-500	over 500
average forgings	up to 10	10-100	over 100
large forgings	up to 2	2-10	over 10
number of type-sizes of forgings, constantly assigned to unit equip- ment, pieces	over 20	6-20	up to 3
Sheet stamping			
small forgings	up to 50	50-200	over 200
average forgings	up to 20	20-100	over 100
large forgings	up to 10	10-50	over 50

Table 2

Technical-economic indicators of forge-press production

	Unit	Series	Large series*
Output per worker, tons	0.05	0.12	1.0
Coefficient of metal utilization of intermediate pro- duct	0.7	0.85	1
Production cost per ton of forgings, rubles	3.9	2.4	1

* Large series production assumed unity.

Table 3

Output according to scale of production in forging and sheet-stamping conversions (% of tonnage)

KShP conversions	Unit	Series	Large series
Forgings*	23	30	47
sheet-stamping	22	36	42
Total	23	33	44

* Including free forging.

A flexible production line (GP line) and a flexible production section (GP section) are a totality of two or more units of basic technological equipment and (or) GP modules, united by automatic control systems and transportation-storage systems (for intermediate, semifinished and finished products, dies, tools and wastes), readjustable for products in a given product list.

The GP line is an organization of a flow of products in an arrangement "unit of technological equipment -- unit of technological equipment."

The GP section is an organization of an independent flow of products in each unit of technological equipment

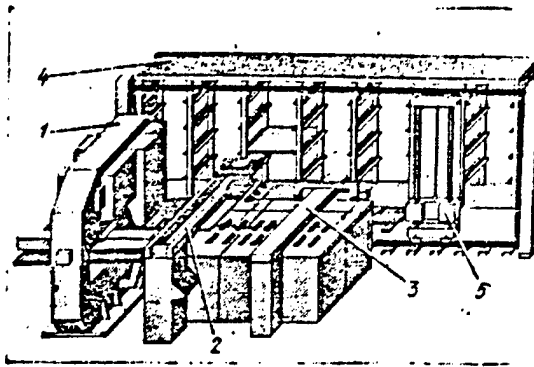

Fig. 5. GP module for sheet-stamping using a 400 k newton turret press.

A flexible production shop (GP shop) is a complex of GP lines, GP sections, GP modules and basic equipment of other types for sequential implementation of technological process and readjustable for manufacturing a given list of products.

A flexible production plant (GP plant) is a complex of GP shops, GP lines, GP sections, GP modules of basic technological equipment, readjustable for manufacturing semifinished or finished products in the plan of basic production and delivery (sale).

Subsectors work on creating equipment which, to the first approximation, may be attributed to flexible automatic production. This is a stage-by-stage process -- from a simpler to a more complicated one, i.e., from a GP module to a flexible automatic production as a whole.

Thus, the Azov SKB [Special Design Buro] of Forge-Press Equipment and Automatic Lines developed an NC GP module (Fig. 4), consisting of a strip intermediate product magazine 1 with means to load and unload strip cassettes; a magazine for dies 2 with a device for the automatic transfer of dies to the working zone of the press and back; shears 3 for cutting the strip wastes; a single-crank 630k newton press 4 with a mechanism for automatic regulation of enclosed height; a device for the automatic feed of strips to press 5, as well as an

automatic feed to move the strips in the working zone of the press by an individual drive. The module operates as follows:

The strip intermediate products magazine is loaded with cassettes with several necessary type-sizes and quantities of strips. The maximum capacity of the magazine is 16 cassettes. The NC finds the necessary cassette and feeds it the loading zone by a transporting device. After machining, a given quantity of parts, the cassette is returned automatically to the magazine. The change of packets and cassettes occurs simultaneously. After that the crosspiece with pneumatic suction devices, separates a strip from the stack and places it on rollers.

With a left feed carriage, the rollers move the strip a given distance with the necessary pitch, assigned by NC, to the stamping zone of the press. After stamping, the finished part of the strip is intercepted by the right carriage, the wastes are cut into given lengths and the remainder of the wastes is ejected.

The cycle is automatic and is repeated the number of times assigned by the program.

The program control can be connected to a computer which makes it possible to build the module into automatic lines, section and shops controlled by ASUTP [Automated System for Technological Process Control]

Depending upon the size of the lot of parts (from 50 to 5000 pieces), the module can process 4 to 13 million parts per year which makes it possible to increase productivity in small series production 8-fold and replace eight universal presses.

The use of the module reduces technological equipment time to 1/2-1/3, labor intensity of manufacturing the stamping equipment to 1/3-1/4 and reduces metal consumption of the equipment by 70 percent. One such module saves 100,000 rubles per year.

Work is being done in the ENIKmash to develop a GP module using a coordinate-turret press and a GP section using a coordinate-turret processing center.

In the turret head of press, the GP module (Fig. 3) has 28 sets of tools, means for loading and unloading 2, 3, intermediate product warehouse 4 and cart-operator 5. It manufactures various types of parts with high productivity and precision. It pierces, cuts out shapes, cleans ridges by milling and threads previously punched holes. The GP module can operate automatically continuously without an operator for 0.5 to 2 shifts depending upon the thickness of the intermediate product and the number of holes punched in the panels.

A GP section (comprehensively automated--KAU) using a coordinate-turret processing center (Fig. 6) with an automatic computer control center (ASU) is designed for manufacturing housings, chassis and panels from sheets in series and small series cold stamping production.

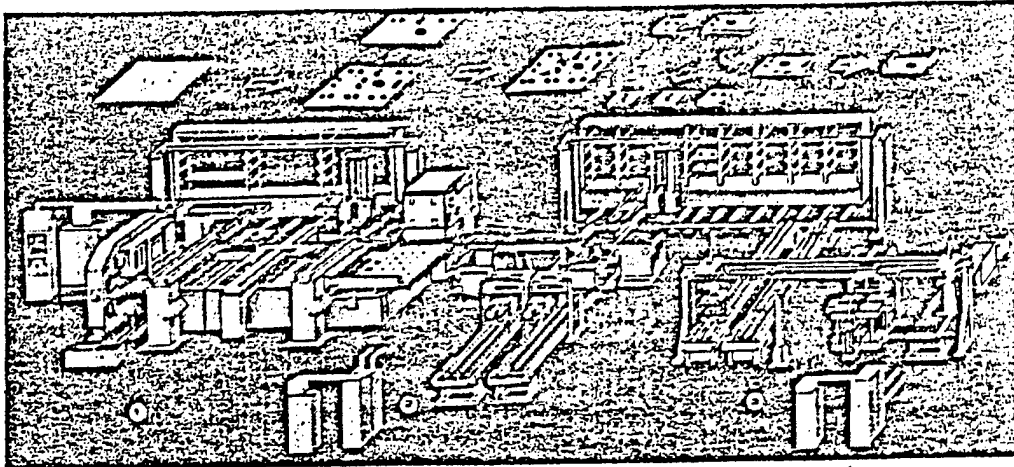

Fig. 6. GP section for manufacturing housings for devices and radio apparatus using a 400 knewton coordinate-turret processing center.

The KAU structural arrangement consists of the following equipment: processing center 1 using a 400 k newton NC coordinate-turret press; NC shears 2 for optimal layout of sheets with mutually perpendicular blades; an NC sheet-bending machine 3 with four-sided bending; means for automatic interoperation transporting, warehousing, loading, unloading and sorting parts; and an automatic control system (ASUTP) KAU.

Each technological equipment unit can operate independently, or as a part of a section which corresponds to the purpose and problems of its creation.

The structural arrangement of the section makes it possible to operate along several routes.

The first route is the basic flow -- the section operates according to the full cycle: the sheet is fed to the OTs [Processing Center] table; it is machined; transferred to the shears; the sheet is cut into rectangular shaped parts; sorted according to types of parts; parts are fed to a transport storage system (TNS) and transferred to the sheet-bending machine; bending operations are performed; finished products are delivered.

The second route is the independent operation of the OTs: sheet fed to the OTs table; sheet machined; sheet delivered to intermediate storage or to the TNS.

The third route is independent operation of the shears; sheet fed to shears table; sheet cut into parts; parts sorted according to types; finished parts delivered to the TNS.

The fourth route is the autonomous operation of the LGM [Sheet-Bending Machine] : parts are fed to table from the TNS stack; parts are bent according to a given program; finished parts are delivered.

The fifth route is the independent operation of the shears and of bending machine: sheet fed to shears table; sheet cut into parts; parts sorted according to types; stack of parts fed to the LGM and TNS; parts bent according to given program; finished parts delivered.

The operation of section equipment on shortened routes is implemented when one type of equipment is underloaded. The OTs is the most loaded in the KAU.

For this reason, a second storage unit with intermediate products is installed ahead of the shears which, if necessary, can be cut, without machining them on the OTs.

There is storage units for finished products obtained on the OTs and which do not need to be cut, or for semifinished products for the shears.

The estimated saving by a section is over 1,200,000 rubles per year.

Organizations, associations and enterprises of the "Soyuzkuzmash" will also create other GP modules, including those for cutting round and square blanks with crank shears; for sheet stamping of parts from blanks using a single-crank open simple-action press and an industrial robot; for sheet stamping from strip blanks using single-crank open simple action presses; for hot die forging using a hot die single-crank press; for pressure die casting of thermoplastic materials using a casting machine; for cutting sheets into strips and squares using automatic complexes; for sheet stamping using two-crank high speed automatic presses and sheet-bending presses with an industrial robot, etc.

New typical GP sections will also be created for sheet stamping using single-crank open presses with industrial robots.

The potential possibilities of flexible production facilities are high. According to data in paper [5], the preparation time for the output of a new product is reduced on the average by 40 percent, unit production costs -- by 10 percent, labor force -- by 30 percent and equipment loading is increased by 30 percent.

The maximum effect of their utilization can be obtained by automating the entire chain in manufacturing the new product -- from the development of the technical documentation to the output of the finished product. This chain must begin with an automatic design system using computers to increase the labor efficiency of the design engineer, the estimator and the technologist [6] .

BIBLIOGRAPHY

1. A. P. Vasil'yev, "Basic Directions in Automation of Forge-Press Equipment." KUZNECHNO-SHTAMPOVOCHNOYE PROIZVODSTVO, 1983, No 11, pp 2-3.
2. Naritsyn, I. A.; Vlasov, V. I. "Automation and Mechanization of Forging and Stamping Technological Processes." Moscow. Mashinostroyeniye, 1967, 388 pages.

3. Selin, M. T.; Mansurov, I. Z.; Podrabinnik, I. M. "Automation and Mechanization of Forge-Press Equipment -- the Most Important Direction in Increasing Forge-Press Productivity." KUZNECHNO-SHTAMPOVOCHNOYE PROIZVODSTVO, 1982, No 12, pp 23-26.
4. Lepikhov, V. G. "Trends in Development of Flexible Productions." MASHINOSTROITEL', 1983, No 9, pp 43-44.
5. "Flexible Automated Systems." EKO, 1983, No 10, p 77.
6. Bal'mont, B. V. "Production Acquires Flexibility." IZVESTIYA, 1983, No 335, p 2.

COPYRIGHT: Izdatel'stvo "mashinostroyeniye", "Kuznechno-shtampovochnoye proizvodstvo", 1984

2291

CSO: 1823/47

OTHER METALWORKING EQUIPMENT

ADVANCED ROLLING MILL TECHNOLOGY ON STREAM

Moscow EKONOMICHESKAYA GAZETA in Russian No 40, Oct 84 p 5

[Article: "Mastering Modern Equipment"]

[Text] The collective of the Alma-Ata Heavy Machinebuilding Plant, working on a large scale economic experient, is fulfilling planned tasks ahead of schedule. Contract deliveries are met fully. The productivity of labor this year will reach the level planned for 1985.

The Alma-Ata workers produce rolling and drawing equipment which acquitted itself well in many enterprises of the country and abroad. Active preparation is being made now to create new machines and improve existing ones. Two prototypes of a drum tube-drawing mill with continuous withdrawal of the tubes have already been made. This will be the basic one in the 12th Five-Year Plan period among such types of equipment. All processes here will be fully mechanized. The productivity of the new mills will be increased 1.5-fold, as compared to the productivity of mills manufactured at present.

For the 12th Five-Year Plan period, a problem was also posed to manufacture a high speed mill for cold rolled pipe. It will include many advanced ideas. As compared to the previous ones this will have an over 2-fold higher productivity.

Casting-rolling machines are being created at the plant that make it possible to introduce low-waste and no-waste technologies. Production will be organized of high productivity mills for producing aluminum rods and fully automatic equipment for rolling pinions. New equipment is being developed in cooperation with the "VNIImetmash."

Difficulties also arise in the process of forming the five-year plan for the plant. The plant has already been in the process of modernization for several years. Glavmaatastroy subdivisions do not execute planned work volumes year after year. "Modernization of basic shops was twice announced as a priority project and both times the schedule was revised," stated V. Kyune, deputy chief of the economic planning department of the plant. "The reason is that the builders work slowly and with poor quality."

Alam-Ata machinebuilders create perfect equipment. Its production requires advanced technology. The basic shops will make it possible to solve this problem. The builders must tighten up.

OTHER METALWORKING EQUIPMENT

UDC 621.73.237.52

DEVELOPMENT OF HYDRAULIC FORGE-PRESSES VIEWED

Moscow KUZNECHNO-SHTAMPOVOCHNOYE PROIZVODSTVO in Russian No 5, May 84 pp 12-13

[Article by V. V. Karzhan: "On Creating New Forge-Press Equipment and Technology"]

[Text] In our country, in the current five-year plan period, one of the most important things is the program for solving the scientific technological problem: "Create on the basis of progressive low-waste technology and organize production of high productivity forge-press equipment, complexes and sections, including NC." Many ministries, scientific research and educational institutions, design buros, production associations and enterprises are taking part in the implementation of this program's tasks. The Experimental Scientific Research Institute of Forge-Press Machinebuilding (ENIIK mash) of Minstankoprom [Ministry of the Machine Tool and tool Industry] is the direct executor of a number of tasks on this program.

During the three years of the 11th Five-Year Plan period, working documentation was developed and prototypes of new equipment were manufactured. Technological processes on the new types of the forge-press equipment were worked out.

With the expansion in the area of the use of hydraulic drives in forge-press production and other machinebuilding sectors, the development and organization of the production of industrial manipulators (robots), there was a greater requirement for precision pipes for manufacturing cylinders with longer working strokes.

The Odessa "Pressmash" Production Association imeni 60-letiya Oktyabrya together with the ENIK mash developed an automatic complex using a model P1941 hydraulic press with a pulsing load force of 12.5 meganewtons. This complex manufactures cylinder pipes up to 140mm in diameter and up to 9000mm long for hydraulic machines. High precision and surface quality insure a minimum of machining and save about 2 tons of pipe rolled stock per year. The use of the new technology will also make it possible to increase the productivity of labor 8 to 10-fold and free up to 40 workers. The annual saving will be over 370,000 rubles.

The Dnepropetrovsk Heavy Press Production Association developed a model PA2646 40 meganewton hydraulic press, equipped with facilities for loading and unloading forgings and with a heating-stamping installation for the isothermal stamping of complicated shaped parts made of metals and alloys hard to deform.

The use of the press in combination with the new technological process reduces the weight of the intermediate product almost to a half which saves over 550,000 rubles per year. The press has a special device for heating the die to the required temperature and maintaining it at a constant level, which insures a favorable temperature-force mode in deformation. The production of a number of presses for isothermal stamping presses is being organized by the plant to expand the area of application of this process.

A great number of stamping hammers are operated in forge-stamp production not equipped with the means of automation and automatic control. Difficult working conditions for stamp operators resulted in a sharp scarcity of such workers.

The collectives of the Voronezh Forge-Press Equipment Manufacturing Production Association imeni M. I. Kalinin, of the Izhevsk Mechanical Institute and a number of organizations and enterprises undertook to solve this problem.

In the last three years, samples were developed of components included in the equipment set: a 1600kg stamping hammer; an automated heater for intermediate products; automatic means to feed intermediate and semifinished products; means to protect against noise and vibration; devices to monitor the speed of parts, adjustment and checking of the hammer; an NC system for the equipment.

The equipment is installed at the machinebuilding plant. After adjusting and testing the set will be released for industrial operation.

Work on organizing low-waste technological processes of hot closed impression die forging using hot alloy steels, the creation of new NC stamping equipment with protection against vibration will double the productivity of labor as compared to existing technology and will save over 160 tons of rolled stock per year; it will also improve working conditions of the operator considerably. Introducing one set will save up to 25,000 rubles per year and the entire annual output will save up to 900,000 rubles per year.

The creation of processing centers is one of the most promising directions in developing modern metalworking production.

The development trend in this direction is reflected in the program for sheet stamping; 25 percent of all tasks is assigned to solving this problem.

The ENIKmash developed and is releasing for series production a model OTs K0126F4 400 kilonewton coordinate-turret processing center to manufacture sheet stampings in frequently-readjustable multi-item production. The turret of the processing center has 28 tools (sets of female and male dies); the center is also equipped with devices with contour cutting, cleaning of the cut out contour by milling, and threading. The size of the intermediate product can be 1600 x 2000mm. The

use of the processing center, depending upon the kind of the product, can double the productivity of labor and more. The center (see Fig.) is equipped with an NC system which makes it possible to include comprehensively automated sections controlled by computers. Due to the increased productivity of labor, the freed metalworking equipment and labor, the metal saved by efficient layout, the introduction of the processing center will save up to 400,000 rubles per year.

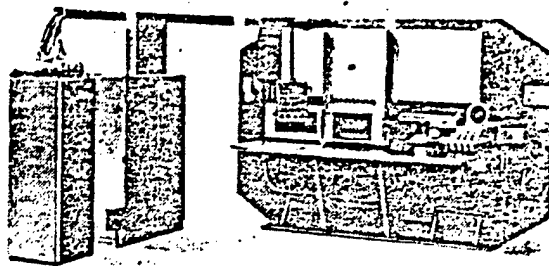

In cooperation with the collectives of the Sal'sk Plant KPO [Design Production Association], the Azov-SKB [Special Design Buro] for Forge-Press Equipment and Automatic Lines and the Taganrog PKTIkuzrobot [Planning-Design Technological Forge-Press Robot Institute] a stamping center using a 630 kilonewton single-crank press was developed and released for production. The press is equipped with a magazine for intermediate strip products with 16 cassettes, a magazine for dies with 16 packets, and devices for the automatic change of intermediate products and dies, feeding strips into the working zone and NC. The model K2128F3 stamping center is designed for small-series readjustable production (for up to 5000 parts in a lot). The increase in labor productivity is 8 to 10-fold and the annual saving is over 800,000 rubles per year.

The November (1983) Plenum of the CPSU Central Committee and the USSR Council of Ministers in their decree "On measures to accelerate scientific technological progress in the national economy" specified, as the most important direction in intensifying industrial production in the national economy, the creation and introduction of flexible production systems. Investigators and designers of forge-press machinebuilding are working on the creation of such readjustable modules, sections and systems to manufacture intermediate products using forge-press equipment.

COPYRIGHT: Izdatel'stvo "Mashinostroyeniye", "Kuznechno-Shtampovochnoye proizvodstvo", 1984

OTHER METALWORKING EQUIPMENT

PLASMA CUTTING TECHNOLOGY IMPLEMENTED

Moscow PRAVDA in Russian 6 Sep 84 p 1

[Article by M. Malkin, engineer (Leningrad): "On Instruction 'Start!'"]

[Text] The first typical module of an automatic flexible production facility for manufacturing parts of shiphulls was received for introduction by the "Ritm" Scientific Research Association.

Recently, scientific staff workers, specialists and innovators gathered around a plasma cutting stand at the experimental section of the enterprise. Each one has in his hands dark glasses.

"Start!" commands Yu. Titkov, candidate of technical sciences.

Narrow darts of plasma, heated to several tens of thousands of degrees stretch out simultaneously from jets of two cutters to steel sheets. Gantries of the "Kristall" machine began moving slowly along lines drawn especially to demonstrate the precision of the work. Finished parts with surprisingly clean edges of different sizes and shapes fall into a tray one after another.

The speed and high quality of the operation pleased the creators of the novelty. There was a time when shipbuilding, which is more frequently of a small series or unit production, was not considered suitable for automation. But here there appeared the first automatic flexible production module for machining housings. It showed the simultaneous operation of only two machines although it is capable of controlling six at once. The great advantage of the module is that its main parameters are typical and it is built basically with already manufactured technological equipment.

Of course, if there was no series manufactured "Kristall" machine that does the basic technological operation today, there would have been no module. However, designers foresaw the possibility of replacing it with a more perfect one.

2291

CSO: 1823/102

OTHER METALWORKING EQUIPMENT

UDC 621.914.22.025.7:621.9.044

NEW TOOLING FOR PLASMA CUTTING TECHNOLOGY

Moscow MASHINOSTROITEL' in Russian No 8, Aug 84, pp 15-16

[Article by M. T. Korotkikh, engineer; M. A. Shaterin and V. B. Shterin, candidates of technical sciences: "End Cutters for Plasma-Mechanical Machining"]

[Text] When milling the edges of sheet intermediate products made of high strength manganese and other special steels and alloys with plasma preheating, milling cutters equipped with plates of metal-ceramic hard alloys are used. Alloy T15K16 and TN-20 and KNT-16 alloy, not containing tungsten have the highest life in machining a number of materials (for example, 34KhN3MFA, 45G17Yu3, 110G13L and 14Kh2N3MA steels) in this case. With plasma heating, which softens the surface layers of the intermediate product considerably, it is most advisable to use cylindrical milling tools. The tooth of the milling tool cuts into the soft metal which sharply reduces the unit loads on the cutting wedge of the tool. This eliminates chipping or crumbling of even such fragile hard alloys as KNT-16 and TN-20. Moreover, it becomes possible to use plates with the slope angle of the cutting edge equal or near zero, which considerably simplifies the making of the tool.

The cylindrical end cutter for milling edges of sheets up to 100mm thick consists of an arbor 2 (Fig. 1) with rings 1 mounted on it that have through wedge grooves. The plates are secured by wedges 3 with screws 4 which, when the plates are tightened, prevent ring 1 from turning in the arbor. This produces some elastic pliability which reduces the intensity of shock loading in the process of cutting in.

The milling tool design makes it technologically efficient to produce basing surfaces for setting the cutting components. Thus, the arbor can be manufactured easily with a play less than 0.01mm. The through wedge grooves of the rings may be ground which produces very flat supporting surfaces and, therefore, high rigidity of the interface between the plate and the support.

The use of tetrahedral plates with a flat forward surface (for example, according to GOST 19049-73) with a 90° tip angle ($\alpha = 100^\circ$; $\gamma = -10^\circ$) makes it possible to utilize all eight cutting edges of the plate. The use of such milling tools with plasma preheating of the intermediate product insures high machining productivity even if the tool is equipped with hard alloy plates without tungsten.

The use of cylindrical milling tools of the considered design is efficient when heating the edge with an oscillating plasma arc, as well as when the basic part of the allowance is cut off by the plasma when the edges are machined on thick sheet intermediate products.

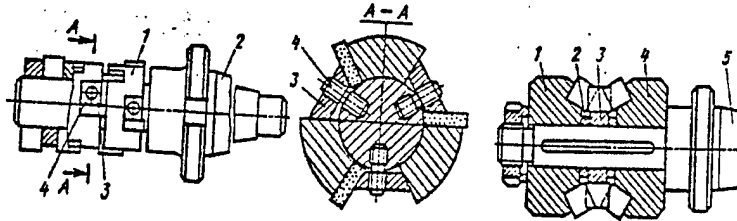

Fig. 1.

Fig. 2

When edges of sheet intermediate products up to 30mm thick are heated by an oscillating plasma arc, efficient machining of a two-sided groove with simultaneous machining of the intermediate edge is possible. A special set of milling cutters was developed for this purpose and are mounted in arbor 5 (Fig. 2). Conical cutters 1 and 4 can be placed at a different distance from each other with an overlap between these cutting plates and cylindrical cutter 3. The value of the intermediate edge (2 to 15mm) is regulated by selecting the thickness of spacer rings 2.

The distinctive design feature of conical cutters 1 and 4 is basing the tetrahedral cutting plates on the conical surface of the housing. The supporting surface of the cutting components is located on teeth secured to the conic bore of the cutter housing. This makes it technologically simple to insure a minimal play in the cutting edges which does not exceed 0.03mm in the final structure. Cutter 3, which machines the intermediate edge, has deep side cutouts for locating the cutting teeth of cutters 1 and 4.

The use of the considered set of cutters in combination with the plasma heater of the intermediate product insures high productivity of the cutting process and permits the use of KNT-10 and TN-20 alloys without tungsten.

Thus, the use of plasma preheating when machining the edges of the sheets makes it possible to use cutters with mechanically secured mansided hard alloy plates

efficiently, while in combination with special cutters, increases the productivity of machining edges and their finishing for welding considerably. In this case, a considerable saving of metal-ceramic hard alloys is achieved.

COPYRIGHT: Izdatel'stvo "Mashinostroyeniye", "Mashinostroitel'", 1984

2291

CSO: 1823/70

OTHER METALWORKING EQUIPMENT

ADVANCED MACHINE TOOLS DEVELOPED AT ORSHA PLANT

Minsk SOVETSKAYA BELORUSSIYA in Russian No 6, Jun 84 pp 44-45

[Article by A. Miloserdnyy, director of the Orsha "Krasnyy borets" Machine Tool Building Plant: "Machine Tools are Becoming More Competitive"]

[Text] In the current five-year plan period, the collective of the Orsha "Krasnyy borets" Machine Tool Plant designed and organized series production, for the first time in domestic machinebuilding, of a set of equipment consisting of 16 models of highly automated precision machine tools. This set of equipment was designed for a single-pass of deep grinding of grooves and shapes, high speed surface grinding, electrochemical and electroerosion machining of surfaces and shapes, and precision shaping grinding. Machining productivity will increase 2.8-fold on the average. The precision reliability and life of the machine tools will increase 1.5-fold. About 11,000 machine tool operators will be freed conditionally. The total saving will be 55.8 million rubles. The technical economic indicators of Orsha machine tools are as good as those of the best abroad and in many cases exceed them.

First, with regard to low-waste technology. Together with the Novosibirsk affiliate of the "Orgstankinprom" Institute, the Orsha Plant developed and introduced a method for manufacturing high strength parts of iron powder, and, as a result of cooperation with the Cherepovetsk Steel Rolling Plant and the TsNII-chermet specialists -- special sections of hot-rolled, high-precision shapes from 45, 40Kh and 12KhZA steels of various cross sections. All this made it possible to reduce to a minimum allowances for machining of parts, use high productivity equipment and develop designs with standardized readjustable fixtures. In cooperation with the Odessa N11SL, special machines with water-cooled permanent molds were introduced. The life of the latter increased 2.5-fold. Scrap was reduced to two percent.

A group of plant innovators proposed a technological process for assembling a basic machine tool on a stepping conveyor; a technological process for assembling hydraulic stations on transfer carts was organized using the brigade work method. As a result, the machine tool manufacturing cycle and man-hours of

assembly work were reduced, labor productivity increased and production areas were saved. A number of progressive technological processes were introduced that made it possible to eliminate the scouring and lapping the guides and to obtain precise finish parameters by grinding. Cutters of hexanite-R and other superhard materials were used widely for milling surfaces of cast iron guides instead of grinding parts from hardened steels, as well as boring holes in dies after heat treatment.

We used basic capital investments to acquire high productivity and highly efficient metalworking equipment such as processing centers for machining housing and base parts; plano-grinding NC machine tools for finish grinding base parts instead of scraping; a laser installation for cutting sheet parts of complicated configurations; an electronic erosion NC machine tool; turning and drilling NC machine tools, etc. Six mechanized flow lines were organized in the machine shop to machine flanges and bushings, guides, shafts and spindles, bedplates, cross carriages and lines for the automatic-turret machining of parts. The introduction of computers made great regularity of production possible.

Since supplier enterprises do not so far guarantee the high quality of their products, the plant organized strict quality control of most incoming products such as varnishes, paints, oils, emulsions, rolled stock, electrical motors, pumps, magnetic plates, hydraulic panels and cylinders, as well as radio electronic apparatus, thyristors, logic components and transistors. One cannot avoid noting the poor quality of NC devices (N331M and N55-1) supplied by the Leningrad Electromechanical Plant. They do not meet today's specifications for individual products. Thus, G12-33 pumps have a high noise level. The OST 2MT21-1-76 permits ribs, burnt-on sand and other defects in castings which are practically impossible to remove while, at the same time, requirements of the exterior surfaces of the machine tools do not permit the removal of defects. Many such examples can be cited. This means that many suppliers still do not have sense of duty and responsibility for making high quality products.

We are giving great attention to socialist competition. We consider the determination of its goals as one of the most important. Therefore, even at the start of the year, we acquaint the collective with problems that it must solve, with measures directed toward improving the equipment and technology, the introduction of new equipment, measures for improving labor conditions, etc. On the basis of initial data, collectives of shops, sections and shifts develop social obligations. Their defense is made annually: collective--at meetings of the staff on preparing competition summaries, individual -- at meetings of shifts with the participation of party, trade union and komsomol members. After that, the obligations are discussed at workers meetings.

An annual schedule subdivided into quarters is developed at the plant for the brigade form of labor organization. Its execution is constantly monitored by management and the trade union committee of the plant. At present, there are 117 brigades at the plant in which 66.7 percent of the total number of industrial-production workers participate.

A comprehensive experimental brigade was created in the machine shop. Wages are piece-rate plus bonus. A brigade combines workers of various trades: grinders, drillers, borers, planers and other specialists. The task is planned for a year with a breakdown by months. Every month it is evaluated and reviewed by the brigade council. The brigade foreman and his assistant plan the work of the collective per shift. The labor productivity in this brigade increased by 15 percent.

The fight to reduce labor-intensiveness is made according to a calendar plan coordinated with shops and the trade union committee. Shop and section management give this plan (for each machine tool model), to the foreman, who, together with the trade group, review reduced or outdated norms. After their review, the shop committee of the trade union and the management and social buro, on setting up labor norms, consider proposals for each shift. Reports are prepared on time norms and evaluations which are signed by the shop chief, the chairman of the shop committee of the trade union and the chairman of the social committee on setting up labor norms. Then the norms are coordinated with the plant trade union committee and approved by the director. The reviewed performance standards and piece work rates are announced to the workers a month before their introduction. In 1983, the labor-intensiveness of the program was reduced by 300,000 norm-hours.

To a great extent, successes achieved by the plant are due to the comprehensive quality control system. A clear-cut system of standards exists in the enterprise. It determines the order of planning, the increasing of the quality of labor and products, as well as establishing interrelationships between the services of the plant, between the plant and suppliers, the methods of gathering and processing data used in production control and the organization of socialist competition. Because of this, the acceptance of products on first presentation was stabilized at 98.1 to 98.3 percent. Total scrap losses decreased. At present, 86.7 percent of the products in the general volume of production have the State Emblem of Quality.

In the future, further improvement in the technical and quality standards of production is planned. The production of NC semiautomatic machine tools and special semiautomatic machines will increase considerably. In 1985, their share in the total volume of machine tools will reach 20 percent.

A new model 3Ye711VF2 machine tool is being created. Its special feature is a single-coordinate NC device that controls the motion of the grinding head, but also the trueing device for the grinding face in the cycle along the periphery, and the electrohydraulic contactless reverse of the longitudinal stroke of the table. This and other innovations improve its technical-economic indicators.

This year, we will change the electrical drives of machine tool feeds to new components (IMS series K511 instead of "Logika T" series logic components). We plan a considerable increase in the volume of production of special machine tools and to raise their technical standards. Several series of specialized machine tools will be designed by using such a progressive finishing method as single-pass deep grinding. We plan to create a robotized machine tool module using special deep-grinding machine tools.

OTHER METALWORKING EQUIPMENT

DESIGN FEATURES OF NEW BROACHING MACHINES REVIEWED

Minsk PROMYSHLENNOST' BELORUSSII in Russian No 2, Feb 84 p 41

[Article by G. Bulankov, chief of the research test post of the Minsk Production Association for Manufacturing Broaching and Cutting Machine Tools imeni S. M. Kirov: "With the Help of the Research Post"]

[Text] About 70 percent of the equipment produced by the Minsk Broaching and Cutting Machine Tool Production Association imeni S. M. Kirov has the State Emblem of Quality. The state tests of products made at the research test center are of great service in this achievement. In 1981-1983 alone, a new series of 13 broaching machine models was tested here. During that period, 10 of these models were certified and recertified for the highest category of quality.

Our test post is not limited to testing according to the requirements of GOST and OST. Great attention is given to predesign checks of design solutions, debugging complicated units, systems and machine tools as a whole. The obtained results make it possible to adopt optimal versions of design, solve promising problems related to raising quality, machining accuracy and machine tool productivity. Actual simulation is used widely and a special test stand was designed and manufactured for this. Machine tool debugging is done according to typical programs and research programs. Observance of typical conditions of tests for many years makes possible an objective evaluation of the efficiency of changes introduced and a comparison between domestic and imported broaching machine tools.

Research tests were made according to special programs and methods. The result was a reduction in the metal consumption of broaching machine tools (by 100 to 700 kg) without deterioration in their basic technical characteristics.

The research post also facilitates an increase in machine tool productivity. This is achieved by introducing manipulators that automatically load and unload parts. Thus, together with other measures, by 1985 this will increase the productivity of broaching and cutting machine tools in the entire program 1.53 to 1.65-fold. A great amount of research was done on finishing off designs

of circular sawing machines, especially of a NC automatic machine. Much work was also done to improve the acoustic characteristics of machine tools. In particular, noise sources were studied, their power was evaluated and versions of noise-suppressing design components were developed. Regrettably, some complementing devices (electrical motors and pump installations) do not meet modern noise characteristics requirements. We would also like to call attention to insufficient modern noise-vibration measuring apparatus at research posts.

There are also other unsolved problems. Thus, the head organization delays the correction and development of new industrial standards. Here is another problem. At present, all measuring equipment used in tests is periodically checked. The set schedule (2 months) is too long, especially if it is necessary to repair some device (this sometimes takes over a year). A number of devices are not repaired in general (for example, the IShV-1 noise and vibration meter, the V7-27 voltmeter, Ts91, Ts90 tongs, etc.).

The broach and cutting-off machine tools manufactured by the Production Association imeni S. M. Kirov are equal to or exceed the level of similar machine tools produced by firms in the United States, FRG, England, Japan, France and Canada with respect to the following indicators: precision, metal consumption, power consumption, degree of automation and productivity. To a great extent, this is a result of a serious attitude toward tests and debugging products by all workers of the association -- from the designer to a worker in the assembly shop.

2291
CSO: 1823/102

OTHER METALWORKING EQUIPMENT

BRIEFS

VACUUM SPRAYING -- Minsk -- It is possible to apply a layer of heat-resistant metal even to a waxed plate by using a new vacuum method for spraying strengthening, decorative and anticorrosion coatings, developed by Belorussian physicists. This was usually done by an electrical arc. However, the temperature in this case is so high that only refractory materials can withstand it. "Investigations have shown that it was not necessary to have a continuous electrical arc," stated E. Techitskiy, doctor of technical sciences, manager of the laboratory of the Electronics Institute of the Belorussian Academy of Sciences. "Material vapors can be sent to the surface of the treated product by short pulses. In this case, the treated part has practically no time to get hot." The development of the original method and technological devices makes it possible to obtain multicomponent materials of a strictly given composition. The first pulse installation to strengthen cutting tools is being prepared to be put in operation at the Minsk Tractor Plant, and since 1985, their series production will begin at one of the enterprises of Belourssia [By D. Patyko] [Text]
[Frunze SOVETSKAYA KIRGIZIYA in Russian 21 Sep 84 p 2] 2291

IMPACT-STAMPING -- A press for impact-stamping of parts was manufactured at the Physio-Technical Institute of the BSSR Academy of Sciences. Its source of energy is ...compressed air. Special features of the novelty are the short time the force is applied, the high level of pressure and the absence of a die. The economic effect of introducing into production only one such press, which won the gold prize at the Brno International Fair, as compared to the usual sheet stamping equipment, is about 200,000 rubles. [By K. Filippov] [Text]
[Minsk PROMSHLENNOST' BELORUSSII in Russian No 5, May 84 p 31] 2291

CSO: 1823/102

AUTOMATED LINES AND AGGREGATED MACHINING SYSTEMS

UDC 621.73:658.011.56.001

VERSATILITY OF FORGE-PRESS MACHINING CENTERS VIEWED

Moscow KUZNECHNO-SHTAMPOVOCHNOYE PROIZVODSTVO in Russian No 5, May 84 pp 18-22

[Article by I. Z. Mansurov and Yu. S. Radyuchenko: "Principal Bases for Arrangement of Forge-Press Centers"]

[Text] The development of the design equipment for shaping metal (OMD) in forge-press machinebuilding is directed toward the automation of traditional forge-press machines (KPM) for universal purposes and the organization of production of automated forge-press equipment complexes and forge-press processing centers (KPOTs) for manufacturing a wide range of products.

The KPOTs is a multioperational (multifunctional) KPM with automatic control of machining, readjustment of technological fixtures and tooling according to a given program for the production of a wide range of intermediate and finished products by the OMD method, as well as the possibility of using other metal-working operations [1]. The KPOTs are used in manufacturing small lots of single type products, when changing over from one type of product to another requires frequent readjustment of tools and working modes.

In creating the KPOTs, the problems of optimal arrangement are solved due to the presence of controlled units and devices for the automatic change of tools and intermediate products.

The basic conditions for grouping KPOTs are:

integration of KPOTs grouping conditions and OMD types on the basis of a basic shaping method;

use of NC;

nature of the degree of tool and technological equipment readjustment;

method of automatic or mechanized setting up of the intermediate product in the working zone;

technologically substantiated control of machining modes and adjustment parameters as applied to machining one or a group of intermediate products;

selection of diagnostic parameters;

unit module principles in grouping processing centers (OTs).

The degree of mechanization and automation of the indicated components, the nature and volume of the integration of technological operations used in KPOTs, characterize their technical standards, whose most important indicator is the use of NC as the basic automation means, as well as the means for raising the degree of utilization of each of the components of the great diversity of the OTs grouping.

The presentation sequence of the grouping criteria characterize the staging in creating the KPOTs and reflects their technological possibilities and the practicability of design execution.

The identification of basic KPOTs components made it possible to develop their classification system that reflects the condition and prospects of their development as multifunctional equipment for the execution of diverse OMD technological processes within automated flexible production facilities (GAP).

Automatic comprehensive development requires that production facilities in which KPOTs operate are capable of being readjusted rapidly, adapting to changes in production requirements, i.e., they have flexibility -- a principle built in NC KPO and in robots, which is the basic GAP.

Each of the GAP parts is based on using computers:

flexible technological equipment -- KPOTs;

system for operational production planning;

system for automated planning and design -- for developing new products and methods for their manufacture.

The combination of the enumerated components into a single whole creates premises for grouping automated flexible complexes, sections, shops and automatic plants that are capable of readjusting automatically for the production of parts for given products.

KPOTs are classified by their technological criteria into classes [1]: first class -- for separating operations; second class -- for volume deformation and third class -- for forming by sheet metal stamping, bending, straightening and shaping.

OTs is subdivided into two subclasses -- single functional multioperational (OFM) and multifunctional (FM) (Fig. 1).

The OFM in the OTs use coordinate turret presses (KRP) to punch holes and contour cutouts, automated forging complexes (AKP) with PU [Control Panel] spring-winding PU automatic machines, etc.

The OFM OTs are named in practice by operations being performed, such as, bending center, forging center and stamping center.

MF OTS are essentially units that execute the following technological operations in machining one intermediate product:

punch holes, make cut-outs, corrugate, thread, etc.;

bend, crimp, punch holes, compress, etc.;

cut strips from sheets, stamp, cut out, bend, etc.

The distribution of KPOTs into classes is determined by the first grouping criterion.

According to the nature of the readjustment of the stamping tool, the parameters of its adjustment and treatment modes as applied to one KPOTs intermediate product are subdivided into two groups.

OTs with intercycle change of tools (MTsSI) is the first group on which machining is done by sequential automatic bringing of the tool to the machined product and being readjusted after a lot of parts is manufactured by installing a new set of tools and changing the program. As a rule, OTs MTsSI are designed to shape the part with several tools for one intermediate product installed in the machining zone. An example of a stamping OTs MTsSI center is an NC KRP for punching holes in panel type parts, while an example of a forging center is the OTs MTsAKP model AKP 500/2.5 with PU.

OTs with a tool change between lots (MPSI) is the second group on which stamping a given lot of products is done by tools installed in the deformation zone in one, two, three and stamping positions.

OTs MPSI are designed for working mechanically simultaneously or sequentially of tools of several secured in turn or installed in the working zone of the parts (single intermediate products/parts of strip or rod intermediate products). The tool set (in the magazine or tool unit) is designed to machine one or several parts. This OTs is readjusted after manufacturing a lot of parts of one type or several parts machined simultaneously. An example of a second group OTs are automatic punching presses equipped with devices to feed and remove intermediate products, laying the parts into stacks and readjusting the tool. Upsetting automatic machines are equipped with devices for readjusting the die unit. It is possible to equip automatic machines with devices for readjusting die units and also to use such machines as KPOTs, i.e., obtain from them the same economic effect in small series production as the use of the usual automatic machines in large-series and series production as compared to equipment not automated.

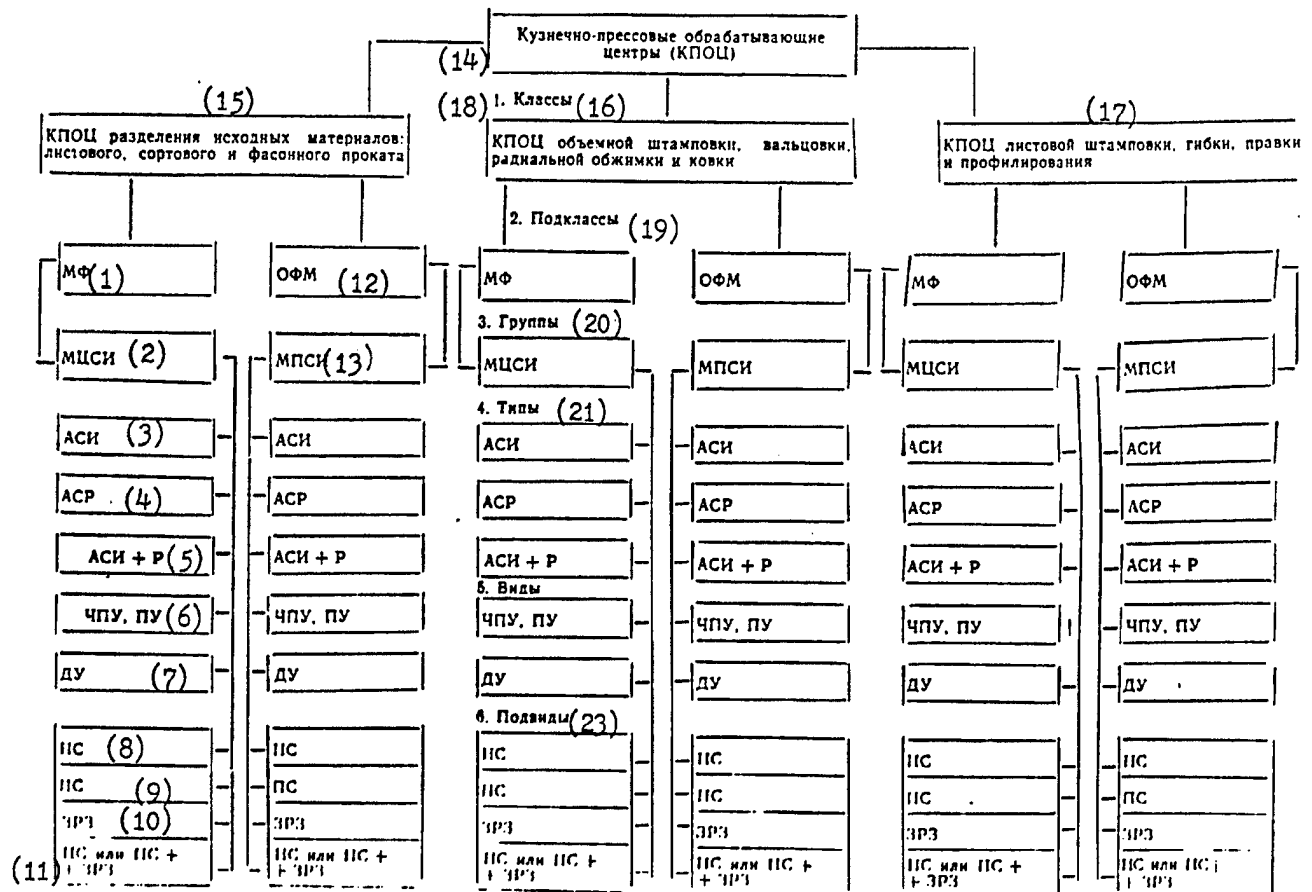

Fig. 1. Classification of forge-press processing centers (abbreviated to KPOTs): 1 -- MF--multifunctional; 2 -- MTSI--intercyclic tool change; 3 -- ASI--automatic tool change; 4 -- ASR--automatic mode change; 5 -- ASI + R; 6 -- NC, PU; 7 -- DU--remote control; 8 -- NS--stationary table; 9 -- PS--mobile table; 10 -- ZRZ--intermediate product grip in the working zone; 11 -- NS or PS + ZRS; 12 -- OFM--single-function multioperational; 13 -- MPSI--change of tool between lots; 14 -- Forge-press processing centers (KPOTs); 15 -- KPOTs for separating united materials of sheet, graded, rolled stock shapes; 16 -- KPOTs die forging, rolling, necking and forging; 17 -- KPOTs for sheet stamping, bending, straightening and shaping; 18 -- Classes; 19 -- Subclasses; 20 -- Groups; 21 -- Types; 22 -- Divisions; 23 -- Subdivisions.

An automatic press is the stamping center of the second group. In it, the processing of intermediate products of one type is completed by readjusting of the tool for the type of intermediate product. OTs MPSI also include machines designed for deforming by using sequentially (stationary or movable) tools on one intermediate product (part), fixed or movable in this working zone. The tool set (in magazines or tool unit) in these machines is for machining only one part. An example of OTs MPSI are automatic sheet-stamping multiposition machines, hot-stamping and cold-upsetting machines with an automatic change of the tool unit.

As follows from that, the above-stated KPOTs distribution by group is determined by the third and fifth grouping criteria.

Depending upon whether the devices are for the rapid change of tools or for changing the parameters of its adjustment or machining modes, the OTs are divided into three types:

- 1) OTs in which the change of tools is required for fully machining one or a group of simultaneous products. For example, NC KRP, sheet-bending OTs with a set of sequentially changed bending tools, AKP with PU, etc.
- 2) OTs, characterized by the fact that full machining of one or a group of sequentially produced products does not require a tool change but it is sufficient to readjust its parameters, treatment modes or both simultaneously. They include radial compression machines (ROM) with PU, spring winding automatic machines with PU, graded shears and automatic complexes of them with PU, etc.
- 3) OTs equipped with devices for the rapid change of tools and treatment modes. They include machines with PU for bending, cutting rotational extrusion, etc.

Thus, the typical classification criterion is determined by the fifth grouping criterion.

The OTs may be divided into two species: the degree of mechanization and the nature of programming readjustments (of tools, modes of operation of equipment and feeding devices, mutual movements of the intermediate product and tools).

The OTs of the first division are equipped with cyclical and inter-cyclical program control.

KRP (Fig. 2) and AKP (Fig. 3) are OTs examples of the first division.

Operating modes of OTs of the second division of working are done with NC or PU, mechanization and automation means are used for readjustment.

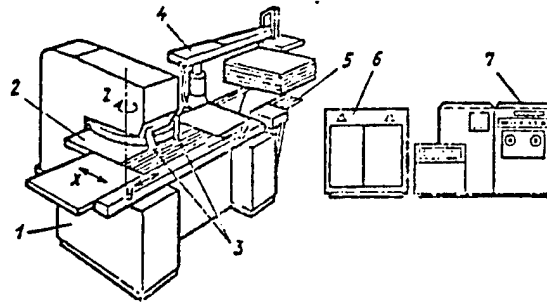

Fig. 2. Grouping arrangement of OTs using a coordinate-turret (KRP) press.
 1 -- press; 2 -- milling mechanism; 3 -- mechanism for intercepting the sheets;
 4 -- loading mechanism; 5 -- unloading mechanism; 6 -- electrical equipment
 cabinet; 7 -- program control.

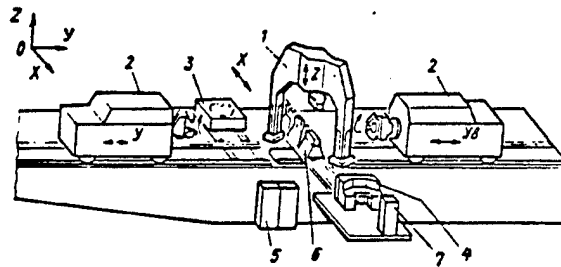

Fig. 3. Grouping arrangement of OTs using a hydraulic press-manipulators
 complex for forging.
 1 -- hydraulic press; 2 -- manipulators; 3 -- cart with rotary table; 4 --
 control panel; 5 -- electrical cabinet; 6 -- device for changing strikers;
 7 -- program control.

According to the fourth arrangement by methods of setting up intermediate products in the working zone, the design of the machine unit for retaining the intermediate products and feeding devices, the KPOTs are divided into four subdivisions.

The first and second subdivision include machines with and without a stationary table. Correspondingly, the intermediate product is secured directly on the table without special grips; the third subdivision is an OTs without a table, but with special gripping devices for securing intermediate products in the

working zone; the fourth subdivision includes OTs that have movable or immovable tables and equipped with double-grip devices for securing the intermediate product in the working zone.

An example of OTs of the first subdivisions are bending machines; of the second subdivisions NC KRP (Chimkent PO [Production Association] Forge-Press Equipment) manufacturer; of the third subdivision -- an OTs developed using the ROM. The automatic forging AKP type complex (Dnepropetrovsk Heavy Press Production Association manufacturer) is a typical representative of the fourth OTs subdivision.

The synthesis of the KPOTs grouping predetermines its design study. The basic stage of grouping is the development of the technological arrangement according to which the following are determined:

composition of operating and regulating motions; nature and number of units that carry tools and technological fixtures for the adjustment, feed and indexing of intermediate products, change in working modes and adjustment of parameters; degree of universality, centralization of machining (parallel or sequential); number of workers and loading positions, etc.

After developing the technological arrangement, there is a coordinate grouping of the machine which is its technological criterion. The coordinate arrangement identifies the composition and order of the combinations of the motions in the machine.

Theoretically, the relative motion with any trajectory can consist of not more than six elementary motions: three advancing along three orthogonal coordinate axes and three rotary with respect to the same axes.

The designation system for the coordinate axes and coordinate motions, regulated by ISO International Organization for Standardization [2] for NC metal-cutting tools, machines for flame cutting, coordinatographs, KRP and machines is adopted to achieve uniform designations in preparing control programs. KPOTs span the following basic combinations of elementary motion arrangements that determine the coordinate arrangement:

rectilinear motion of the intermediate product along two axes, rotation of the unit with tools and rectilinear motion of the tool along one axis (characteristic for the KRP). Structural formula KRP-XYOSZ (see Fig. 2) which contains designations of the sequentially linked units: table X, carriages Y, bedplate with the tool magazine; vertical slide bar of the press and bracket Z [3];

advancing rectilinear rotary motions of the intermediate product (as a rule simultaneous) and of the forging manipulator-along the horizontal axes; rectilinear motions of the press frame with the upper striker -- along the vertical axis; rectilinear (rotary) motions of lower strikers under upper strikers (characteristic of the AKP). Structural formula AKP-2 (Y; Y_B) XYZ (Fig. 3), in which there are designations of sequentially linked units; two manipulators (Y, Y_B), lower striker unit X, bedplate O, press frame with upper striker Z.

Of great importance in synthesizing OTs arrangements is the optimal distribution and sequence of motions of the intermediate product and the tool. There are several possible versions of the distribution of elementary movement components between the intermediate product and the tool.

In most cases, the elementary motion of intermediate products and tools, which are executed simultaneously according to the machining cycle, differ substantially. In this connection, there is a difference between the main motion, the fastest, and the feed motion which may be slower than the main motion hundreds and even thousands of times. Such feed motion takes place, as a rule, in individual kinds of KPM such as ROM, electric upsetting, bending machines, as well as in automatic forging and initial rolled stock separation complexes, etc. Like machining [3], the kinds of motion in these machines, in their turn, can be separated into the following:

working motions executed under load;

setting up motions executed unloaded. They are used to position the tools and intermediate products before machining. They may or may not coincide in direction with the shaping motions;

indexation motions which are setting up motions for manifold repetition on the section of the shaping product (for example, in forging and rotational extrusion operations);

idle movement (of reverse stroke) in used to withdraw the tool from the intermediate product or the intermediate product from the working zone;

auxiliary (additional) motions used to change tools, replace intermediate products, etc.

The composition of the elementary shaping and auxiliary motions and the relationships between these motions determine the kinematic structure of OTs, which is the basis of synthesizing the OTs arrangement and design. Thus, when synthesizing the general OTs structure, based on the technological arrangement, the coordinating arrangement is developed that determines its kinematic structure. The kinematic structure, combining in itself the technological and structural criteria of OTs, is the basis for synthesizing basic and structural arrangements -- the final stages of synthesizing the general arrangement.

The basic arrangement determines the kind and type of the OTs, based on the structural features of the basic units of the control system and other criteria.

The basic criterion for evaluating the expediency of changing the traditional OTs equipment is obtaining an economic effect. As a rule, the criterion of effectiveness is whether there is enough of a product list for the OTs. It is advisable to create the OTs on the basis of new and modernized machines when the technological process requires several types of tools or shifts of intermediate products in the working zone.

We will consider the arrangement of a stamping center for shaping a product with sequential tool by the multipositional stamping of a sheet stamping automatic machine.

The experience of automatic sequential stamping of parts indicates that stampings on a multipositional stamping center, using a multipositional automatic press has indisputable advantages when stamping medium size and large parts.

For an automatic multipositional sheet stamping press to meet the requirements of small series production and of a widely universal stamping center, OTs MTsSI, it is necessary to solve a number of grouping problems which are characterized by basic structural criteria:

automatic loading of the intermediate product by a sheet-stacker or feed of rolled material to initial cut position; three-coordinate motion of the intermediate product by grip feed (by manipulator) into the stamping space along the stamping positions; clamp-lift, relative motion, lower-unclamp; return of grip to initial position;

rigid mechanical drive with all functions done in a strict compulsory sequence in a given range of speeds;

rapid readjustability, remote control of die change by extensible mechanized sequential action of plates under the dies;

availability of control programs and a diagnostic center that monitors the causes of failures of the automatic press and the die tool.

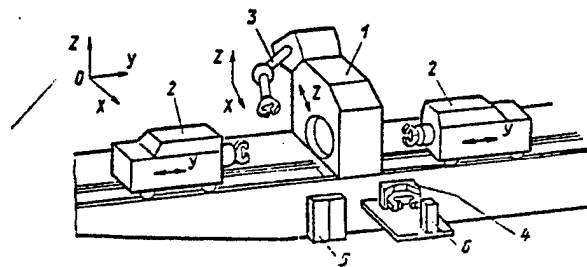

Fig. 4. Grouping arrangement of OTs using a radial-cogging machine:
1 -- radial-cogging machine; 2 -- manipulator; 3 -- loading and unloading device;
4 -- control panel; 5 -- electrical cabinet; 6 -- program control.

The grouping of a shaping center using ROM to produce stepped shafts has its distinguishing features. As other KPOTs, this OTs, using a ROM as compared to a ROM with manual or cyclic program control, has advantages in productivity and the quality of products obtained.

The creation of the OTs using a ROM also preceded a solution of a number of grouping problems whose basic ones are typical, and original by technological criteria. The typical criteria include automated loading of the intermediate product to the feeding device, reorientation of the intermediate product into the feeding device and unloading the finished product from the feeding device.

It should be noted that such a typical design grouping criterion, as rapid replacement of strikers and fixtures of the feeding device has still not found an industrial solution and the readjustability of the die fixtures is limited only by changing the position of strikers with respect to the axis of the intermediate product being machined.

As applied to the ROM, such readjustment of strikers is sufficient to produce stepped products with various configurations of steps within the diameter range of the installed strikers. Thus, the reequipment of the ROM in the OTs is sufficient along with the solution of the indicated typical group arrangement on loading intermediate products and unloading the finished product, is to equip the machine with NC that will provide only for an automatic change in the striker position in the process of their machining without changing them which stresses the originality of the grouping criterion for a "readjustable" fixture. To increase the productivity of OTs using ROM, additional heating devices (when working with heating of intermediate products) are provided with loading and unloading mechanization devices. As compared to the usual ROM that have manual or cyclic program control, the NC ROM with two heating devices doubles or triples the productivity.

An example of an OTs using a ROM is a series of domestic ROM, equipped with mechanized heating devices, as well as automatic loading and unloading devices. The grouping arrangement of OTs using ROM is shown in Fig. 4. When creating KPOTs with multipositional cold and hot stamping automatic machines and presses for multipass cold extrusion, universal automatic bending machines, pressure die casting of thermo-plastic and thermoactive materials, spring coiling automatic machines, it is necessary to solve grouping problems. This will make it possible to further develop KPO designs and create high productivity mobile KPOTs types with wide technological possibilities for GOP.

BIBLIOGRAPHY

1. Radyuchenko, Yu. S.; Mansurov, I. Z. "Forge-Press Processing Centers." Review, Moscow. NIIMASH, 1982, 63 pages.
2. ISO recommendation R-841. Axis and motion nomenclature for numerically controlled machines, 1968.

3. Bragov, Yu. D. "Analysis of Grouping Metal-Cutting Machine Tools."
Moscow. Mashinostroyeniye, 1978, 208 pages.

COPYRIGHT: Izdatel'stvo "Mashinostroyeniye", "Kuznezhno-shtampovochnoye
proizvodstvo", 1984

2291

GSO: 1823/52

END