

JPRS-JST-86-001

✓10 January 1986

# Japan Report

SCIENCE AND TECHNOLOGY,

19981125 121

DTIC QUALITY INSURED

**FBIS** FOREIGN BROADCAST INFORMATION SERVICE

REPRODUCED BY  
NATIONAL TECHNICAL  
INFORMATION SERVICE  
U.S. DEPARTMENT OF COMMERCE  
SPRINGFIELD, VA. 22161

#### NOTE

JPRS publications contain information primarily from foreign newspapers, periodicals and books, but also from news agency transmissions and broadcasts. Materials from foreign-language sources are translated; those from English-language sources are transcribed or reprinted, with the original phrasing and other characteristics retained.

Headlines, editorial reports, and material enclosed in brackets [ ] are supplied by JPRS. Processing indicators such as [Text] or [Excerpt] in the first line of each item, or following the last line of a brief, indicate how the original information was processed. Where no processing indicator is given, the information was summarized or extracted.

Unfamiliar names rendered phonetically or transliterated are enclosed in parentheses. Words or names preceded by a question mark and enclosed in parentheses were not clear in the original but have been supplied as appropriate in context. Other unattributed parenthetical notes within the body of an item originate with the source. Times within items are as given by source.

The contents of this publication in no way represent the policies, views or attitudes of the U.S. Government.

#### PROCUREMENT OF PUBLICATIONS

JPRS publications may be ordered from the National Technical Information Service, Springfield, Virginia 22161. In ordering, it is recommended that the JPRS number, title, date and author, if applicable, of publication be cited.

Current JPRS publications are announced in Government Reports Announcements issued semi-monthly by the National Technical Information Service, and are listed in the Monthly Catalog of U.S. Government Publications issued by the Superintendent of Documents, U.S. Government Printing Office, Washington, D.C. 20402.

Correspondence pertaining to matters other than procurement may be addressed to Joint Publications Research Service, 1000 North Glebe Road, Arlington, Virginia 22201.

10 January 1986

# JAPAN REPORT

## SCIENCE AND TECHNOLOGY

### CONTENTS

#### AEROSPACE SCIENCES

Earth Sensor for Artificial Satellite Control Discussed (Kunio Nakamura; SENSEI GIJUTSU, May 85) .....	1
Satellite 'Sakura' To Be Deactivated (KYODO, 13 Nov 85) .....	13
Agreement on Joint Light Airliner Reached With PRC (KYODO, 19 Nov 85) .....	14
New Osaka Airport Project Sparks Trade Friction (Susan Moffat; KYODO, 19 Nov 85) .....	15
French Businessmen Urge Aircraft Purchases (KYODO, 7 Nov 85) .....	17
MITI Pushes Plan To Develop ATP Aircraft Engine (KYODO, 14 Oct 85) .....	18

#### CHEMICAL ENGINEERING

Fiber Reinforced Plastics Described (NIKKO MATERIALS, Jan 85) .....	19
--	----

#### ENERGY

MITI Sees 'Perception Gap' on Cook Inlet Oil (Sei Ogawa; KYODO, 2 Nov 85) .....	43
Japanese Oil Companies' Interim Business Results Heavily in Red (MARUBENI PETROLEUM REPORT, 1 Dec 85) .....	45
Idemitsu To Expand PRC Offshore Oil Drilling (KYODO, 8 Oct 85) .....	49
MITI Urges More Investment by Power, Gas Firms (KYODO, 15 Oct 85) .....	50

MITI To Submit Gasoline Import Decontrol Bill (KYODO, 4 Oct 85) .....	51
TDK Affiliate Develops New Solar Power Cell (KYODO, 21 Nov 85) .....	52
<b>NUCLEAR DEVELOPMENT</b>	
Construction Begins on Enriched Uranium Plant (KYODO, 13 Nov 85) .....	53
MITI Advisory Group To Work Out Nuclear Policy (KYODO, 11 Nov 85) .....	54
<b>SCIENCE AND TECHNOLOGY POLICY</b>	
COCOM To Ease Control on High-Tech Exports to PRC (KYODO, 11 Nov 85) .....	55

AEROSPACE SCIENCES

EARTH SENSOR FOR ARTIFICIAL SATELLITE CONTROL DISCUSSED

Tokyo SENSEI GIJUTSU in Japanese May 85 pp 69-74

[Article by Kunio Nakamura, Matsushita Giken, Matsushita Technical Research Company: "Earth Sensor for Artificial Satellite Attitude Control"]

[Text] When in space, artificial satellites operate in general accordance with the law of gravitation but, in reality, there are various external disturbances and orbital balances which cannot be maintained by the attraction of the earth and the centrifugal force of the satellite alone. Hence, the necessity for confirmation of the state of satellite operation and the appropriate control of satellite attitude. Also, deciding a certain attitude is absolutely necessary to put a satellite in its planned orbit after launching by a ground rocket. Further, weight is one of the most important items of design in the launching of satellites and the amount of fuel used for attitude control must be minimized, but this hinges on how precisely the attitude can be detected. Application satellites in orbit are operated according to their purpose. Attitude control is important to any satellite, whether a meteorological satellite, communications satellite, or broadcasting satellite. This is evident from the fact that the antenna, is of no use if not in its planned direction. For these reasons, satellites are designed so that their attitude can be detected by sensors.

As for sensors, there are the earth sensor, the solar sensor, the sidereal sensor, the geomagnetic sensor, etc. The earth sensor is one of the most important to application satellites operated around the earth. This sensor has the function of deciding the attitude of a satellite to the earth and can decide two of the three attitude axes. An attitude detecting system is designed by combining it with the solar sensor to decide all three axes. The earth sensor is sometimes used to decide only one axis.

The definition of the three attitude axes is shown in Figure 1. Normally, the roll axis is taken in the direction the satellite proceeds and the yaw axis is taken in the direction toward the center of the earth. The remaining direction is the pitch axis. Of these three axes, the yaw axis attitude cannot be determined by the earth sensor.<sup>1</sup>

Figure 1. Definition of Attitude Axes of Artificial Satellite (Attitude to Earth)

Key:

1. Earth
2. Orbit of artificial satellite
3. Roll axis
4. Yaw axis
5. Artificial satellite
6. Pitch axis

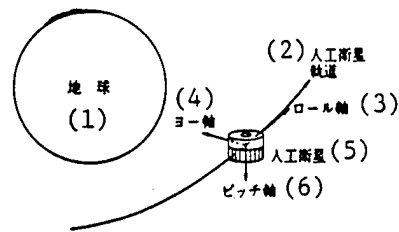

### 1. Principle of Earth Sensor

There are various formulas for earth sensors but all are optical sensors which detect infrared rays radiated from the earth. The earth sensor is also known as the "horizon detector" and is used to detect the attitude of the satellite to earth by discerning the horizon. To determine the horizon, it perceives infrared rays radiated from the earth. Specifically, it detects infrared rays radiated from the atmosphere with a wavelength in the 14-16  $\mu\text{m}$  band (infrared radiation zone of carbon dioxide) or the 22-40  $\mu\text{m}$  band (infrared radiation zone of aqueous vapor). Since this atmosphere is only about 40 km from the earth, (less than 1 percent of the earth's radius of 6,378 km), there is no issue if this is used as the standard. The reason infrared information is provided is for stability.

Visible information varies widely, depending on solar irradiation, because it is reflected or scattered light from solar irradiation. Thus, in visible light the earth sometimes is not round when it is viewed from the satellite. This does not occur with infrared rays of 10  $\mu\text{m}$  or more because these are radiated from normal-temperatured objects. Since infrared radiation intensity is greatly affected by temperature, a wavelength with as stable a radiation intensity as possible is selected from the standpoint of S/N. Figure 2 shows forecast calculated values for spectrum distribution of infrared radiation from the earth.<sup>2,3</sup> There is a wavelength domain which varies according to the season and the conditions of day and night. For example, almost complete stability at an average  $250 \mu\text{W}/\text{cm}^2/\text{Sr}\cdot\mu\text{m}$  prevails in the carbon dioxide infrared radiation band of 14-16  $\mu\text{m}$ . This means that infrared rays from the ground surface are absorbed by carbon dioxide in the atmosphere and do not reach the satellite, while infrared rays from carbon dioxide in the atmosphere with relatively stabilized temperatures do reach the satellite. In this wavelength band, there is a fall from the black body radiation spectrum distribution curve for ground surface temperature. This is because air temperature above, approximately  $-40^\circ\text{C}$ , is lower than the ground surface temperature (see Figure 2).

This provides excellent information with high S/N because its infrared radiation intensity is low but stabilized.

Methods to detect the horizon attitude information can be generally divided into the following two:<sup>4</sup>

Figure 2(a). Spectrum Distribution of Infrared Radiation from the Earth<sup>2,3</sup> (winter, latitude 30-40°, night)  
 --Calculated, using atmospheric observation data from different parts of North America  $\gamma^1$ : nadir angle (see Figure 3)

Key:

1. Infrared radiation energy
2. Carbon dioxide infrared radiation band
3. Aqueous vapor infrared radiation band
4. Wavelength

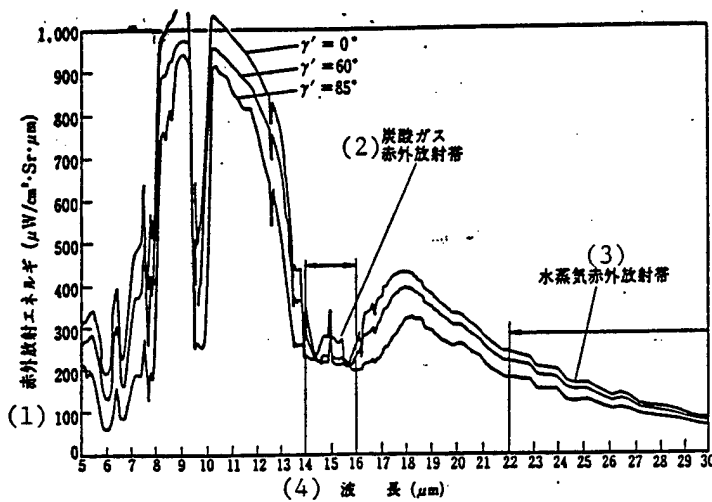
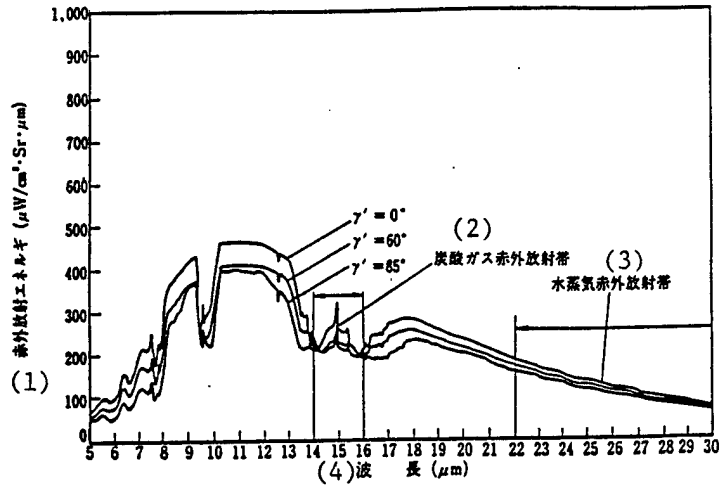
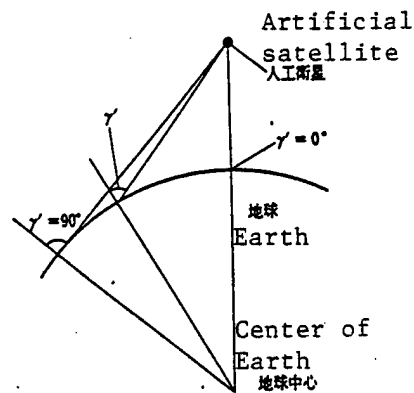

Figure 2(b). Spectrum Distribution of Infrared Radiation from the Earth (summer, latitude 30-40°, daytime)  
 --Calculated, using atmospheric observation data from different parts of North America  $\gamma^1$ : nadir angle (see Figure 3)

Key:

1. Infrared radiation energy
2. Carbon dioxide infrared radiation band
3. Aqueous vapor infrared radiation band
4. Wavelength

Figure 3. Definition of Nadir Angle  $\gamma^1$



### Balance Type

In Figure 4, the balance type formula confirms the attitude of the satellite by the balance of infrared signals from a plural number of detecting elements. If the attitude of the satellite deviates, the balance of infrared signals B and D in Figure 4 changes and signal B becomes larger. This shows that the attitude of the satellite has deviated to the right.

Figure 4. Chart Showing Principle of Attitude Detection by Balance Type Earth Sensor. A, B, C and D: infrared detecting elements

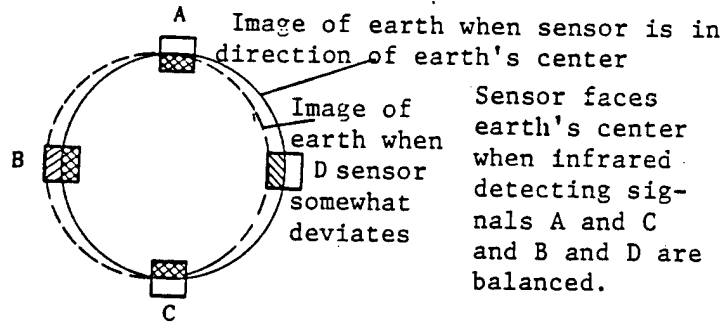
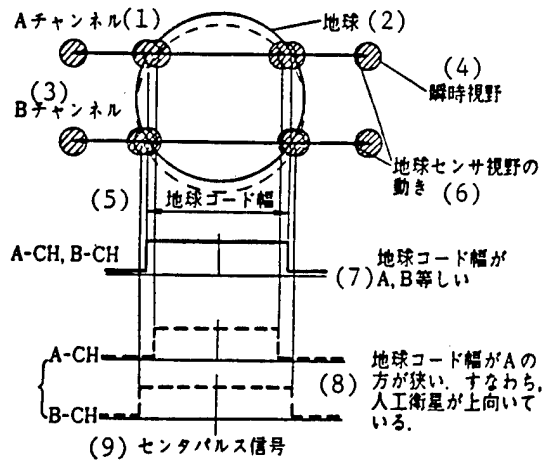

Figure 5. Chart Showing Principle of Attitude Detection by Scan Type Earth Sensor

Key:

1. Channel A
2. Earth
3. Channel B
4. Instantaneous field of vision
5. Earth code width
6. Shift of earth sensor's field of vision
7. Equal earth code width for A and B
8. Earth code width is smaller for A. Thus, artificial satellite turns up.
9. Center pulse signal



### Scan Type

In Figure 5, the scan type detects the position of the earth's end (horizon) by scanning the field-of-vision of the infrared detector. Methods of scanning include use of the satellite's spin, prism lens and rotary or vibrative mirrors attached to the scan wheel. It perceives the space/earth boundary through changes in infrared signals. In Figure 5, if the satellite rotates up from a position of facing the earth (represented by the solid line), the earth now (represented by the broken line) results in changes of the earth

code widths in channels A and B. In other words, the channel A code width becomes narrower than the channel B code width; thus, one can see that the satellite has turned up. This is roll axis attitude. However, two channels are not always necessary. Since earth code width can be calculated from the altitude and attitude of a satellite, it is possible to determine roll axis attitude from information in Figure 5 and the satellite's orbit. Information on pitch axis attitude can be obtained by observing the horizon and setting a standard signal in the field-of-vision scanning system and using it as the standard. Specifically, if the center pulse signal (scanning system center) in Figure 5 is used as the standard, the leading or trailing of the earth's pulse signal provides pitch axis attitude information.

## 2. Composition of the Earth Sensor

The main composition of the earth sensor is indicated in Figure 6. The formulas have several unnecessary components. In the balance formula, the field-of-vision scanning system is unnecessary; in the scanning formula, the scanning system is also unnecessary. In the digital signal processing system, the changes from earth pulse signals into roll and pitch signals, is not always included in the earth sensor. The solar sensor may, in some designs, be included to contend with solar interference.

Figure 6. Composition of Earth Sensor (By formulas, some components are unnecessary.)

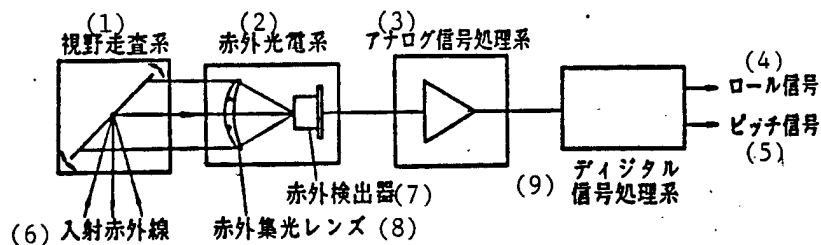

Key:

- |                                    |                                     |
|------------------------------------|-------------------------------------|
| 1. Field-of-vision scanning system | 6. Incident infrared ray            |
| 2. Infrared photoelectric system   | 7. Infrared detector                |
| 3. Analog signal processing system | 8. Infrared condenser               |
| 4. Roll signal                     | 9. Digital signal processing system |
| 5. Pitch signal                    |                                     |

The components may be classified by functions as follows:

1. Optical system and infrared photoelectric system (including alignment)
2. Signal processing electronic circuit system
3. Power system (including DC/DC converter)
4. Relay system (connector and wire harness)
5. Structural system

A DC/DC converter is often included in the power system of an earth sensor because normally the primary supply voltage of satellites is 29 V. Earth sensors are designed to detect weak infrared signals from the earth. It is, important to safeguard them from various wave and power line noises and, from the standpoint of designing electromagnetic adaptability for this purpose, the above-mentioned c, d and e [as published] are key components.

### 3. Evaluation Factors of the Earth Sensor

The purpose of the earth sensor is to detect the attitude of a satellite. Precision is most important but weight, environmental resistance and reliability are evaluation factors that cannot be ignored. Important evaluation factors affecting the earth sensor as follows:

1. Precision
2. Weight
3. Power consumption
4. Reliability
5. Environmental resistance
6. Operating restrictions

In addition to the above, performance specification, price, manufacturing schedule and the relative ease of ground test evaluation are important.

**Precision:** This should be evaluated separately for random and bias errors. Random errors are caused by sensor noise. Bias errors are unpredictable errors developing slowly over a long period of time and due mainly to:

- (i) Intensity variation of infrared radiation from the earth.
- (ii) Variation of earth sensor characteristics due to change of ambient temperature.
- (iii) Variation due to alignment error and temperature change.
- (iv) Change of satellite altitude.

These errors are related to satellite operation conditions and cannot be evaluated by the earth sensor alone. Random errors are the exception and can be evaluated solely by the earth sensor. They are also known as single-sensor errors. Response speed capacity is included as a cause of errors, but can be controlled to some extent by repeated signals in system design.

**Weight:** Lightening alone is not enough. The weight of an earth sensor must be designed comprehensively, taking into consideration resistance to vibration, countermeasures against errors (due to temperature change) and the effects of electromagnetic shielding.

Power consumption: This is an important item of evaluation because the power supply from the solar cell is limited by satellite design.

Reliability: Once launched into space, instruments can rarely be repaired. Therefore, the necessity of careful design. Normally, work to enhance certainty is performed by considering reliability at the design stage, quality control at the stage of manufacture and evaluation testing. Specifically, this work begins with the study of parts and materials to be used and must include design efforts to help eliminate single disorders (disorders at single points that stop normal operation. Appropriate allowances for resistance to environments should also be made. There must be a balanced and sound design with consideration for reliability apportionment.

Resistance to environments: It is necessary to be able to withstand both rocket launching environment and space orbit. These environmental conditions are requirements determined by the design of the satellite and rocket and represent environmental interfaces by the addition of satellite attaching conditions, taking into consideration the capability of the earth sensor.

The main items are as follows:

1. Resistance to vibration and impact
2. Resistance to heat and vacuum
3. Resistance to radiation
4. Electromagnetic adaptability

Restrictions in operating: This must be considered in conjunction with the various items of evaluation. Satellite precision in the correct state of attitude (null state) and precision at the time of deviation from the null state are not always identical; rather, they disagree in most cases. The extent to which this null precision can be maintained is important to operation. Differences develop in the sensor's ease of use and operating restrictions. The earth pick-up domain and the extent of interference by the sun and the moon must also be studied.

#### 4. Outline of Various Earth Sensors

Most earth sensors used in Japan are European and American products. Japanese earth sensors, using a unique pyroelectric infrared detector differ from the thermistor and thermopile infrared detectors of Europe and America. They are produced by Matsushita Giken Co. The evaluation of earth sensors is concerned with the satellite systems design and simplistic comparison is impossible with many parts. An outline of leading European, American and Japanese earth sensors is given in Table 1.

Precision: Precision varies according to the satellite's altitude. Generally, geostationary altitude provides high precision.

Table 1. Outline of Leading Earth Sensors

Formula	Balance Type				Scan Type		
	Quantech Model 5100	Quantech Model 5106	Burns Model 13-401	Lockheed LAHS	Lockheed NOHS	Matsushita Giken PHI-LM*	
Manufacturer Model	Quantech Model 5100	Quantech Model 5106	Burns Model 13-401	Lockheed LAHS	Lockheed NOHS	Matsushita Giken PHI-LM*	
Altitude of artificial satellite	Geostationary altitude (36,000 km)	Low altitude (800-1,200 km)	Low altitude (740-925 km)	Low altitude (837 km)	Geostationary altitude (36,000 km)	Transfer orbit (15,000-36,000 km)	
Infrared detector	Thermocouple	Thermocouple	Thermopile	Thermistor	Thermistor	Pyroelectric element	
Field-of-vision scanning formula	---	---	---	Mirror scan	Mirror scan	Using satellite scan	
Infrared wavelength used	22-33 $\mu\text{m}$	14-16 $\mu\text{m}$	14-16 $\mu\text{m}$	14.1-15.8 $\mu\text{m}$	14.1-15.8 $\mu\text{m}$	14-16 $\mu\text{m}$	
Attitude detecting precision (Nominal altitude 3 $\sigma$ )	0.046°	0.15°	Pitch axis: 0.068° Roll axis: 0.048°	0.1°	0.05°	0.1° (infrared input level nominal) (random error)	
Weight	2.52 kg	3.38 kg	4 kg	1.5 kg	1.82 kg	1.12 kg	
Power consumption	3.2W	3.2W	1.35W	3.1W	3.5W	2.3W	
Redundant system	Yes	Yes	Yes	Yes	No	Yes	
Reliability (survival rate/hour)	0.9988 (7 years)	0.9982 (7 years)	0.9976 (2 years)	0.95 (2 years)	0.9488 (1 year)	0.9999999 (200 hours) 0.996 (7 years)	

\* PHI-LM: Pyroelectric Horizon Crossing Indicator Learning Model

Weight: Earth sensors of the balance type are heavy because of their temperature controlling devices while the scan type sensors are light in weight.

Reliability: The reliability of earth sensors and their life requirements vary depending whether there is a redundant system present. A comparison of their reliabilities is difficult, the diversity of conditions required by satellite systems makes it impossible to evaluate them in general terms. Table 1 shows only some details of earth sensors.

Space tests on Japanese earth sensors (Table 2) using pyroelectric infrared detecting elements were conducted, utilizing scientific research satellites from the Institute of Space and Astronautical Science. Data was accumulated. Later, a scan type earth sensor was developed jointly by the National Space Development Agency and the Aeronautic and Space Technology Research Institute as experimental equipment to be carried by the Technological Experiment Satellite IV (Kiku No 3).<sup>5</sup> Photo 1 [omitted] shows its rotary head and Figure 7 shows its mounting on Kiku No 3.<sup>5</sup> It is composed of two rotary heads and an electronic apparatus. This scan type earth sensor fulfilled its objectives during two years of operational research and produced useful space data.<sup>5,6</sup>

It was on the basis of these results that the Japanese earth sensor in Table 1 was developed. An engineering model (EM) has been developed under the ETS-V Project. Work using a laboratory model (LM) under the research plan (Tsukuba Space Center) was done. It will be used in the transfer orbit (orbit prior to entry into geostationary orbit) of Technological Experiment Satellite V (ETS-V). The completion of a satellite-carried model is scheduled for the summer of this year. The earth sensor, when completed, will be incorporated into the attitude control subsystem and into the satellite system. ETS-V is scheduled to be launched from the Tanegashima Space Center in the summer of 1987.

This earth sensor is called the earth sensor for spin phase use (PHI: pyroelectric horizon crossing indicator) because it is designed for use in satellite spin stability. Under the ETS-V Project, it is called spin earth sensor (SES). Photo 2 [omitted] shows the SES-EM. The optical package and the infrared detector, main components of this earth sensor, are shown in Photo 3 [omitted]. Through the field-of-vision scanning system and the digital signal processing system in Figure 6 are not included, two sets composed of an infrared photoelectric system, a signal processing system and a power source are housed in the monoblock structure and form complete redundant systems. The field-of-vision direction of the optical package is tilted upward and downward 40 each; thus, field-of-vision scanning for an angular aperture of 80 will be performed by the spin of the satellite. The earth signals are digitalized so that output by two values: L (space) and H (earth) may be possible. The main specifications are shown in Table 3.



A future development plan for precision earth sensors (Tsukuba Space Center) has been started. It will be mounted on the Technological Experiment Satellite IV (satellite of the National Space Development Agency).

Table 2. Space Tests on Domestically Produced Earth Sensors (Manufacturer: Matsushita Giken Co.)

Earth Sensor	Type	Satellite	Year Launched	Delivered to:
Earth sensor for spin phase use	HOS-01	Tansei #2	1974	Tokyo University Space Research Institute*
do.	HOS-01	K-9M-47	1974	do.
do.	HOS-01	Taiyo	1975	do.
do.	HOS-01	Tansei #3	1977	do.
do.	HOS-01	Tansei #4	1980	do.
do.	HOS-01	Hinotori	1981	do.
Scan type earth sensor	HS-01	For ground test	----	Aeronautic and Space Technology Research Institute
do.	HOST-01	Kiku #3**	1981	National Space Development Agency
Earth sensor for spin phase use	HS-02	TT500A	August 1983	Aeronautic and Space Technology Research Institute
do.	PHI-LM	----	----	National Space Development Agency
do.	SES	ETS-V	1987	do.

\* Now known as the Institute of Space and Astronautical Science

\*\* ETS-W

Figure 7. Mounting of Scan Type Earth Sensor (HOST)<sup>5</sup>  
(Mounting on Kiku No 3, Technological Experiment Satellite)

Key:

1. Head 1
2. Electronic apparatus
3. Head 2
4. Size of Kiku No 3 Length : 2.77 m  
Diameter : 2.1 m

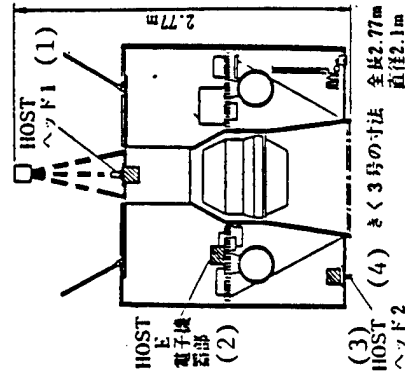

Table 3. Earth Sensors for Spin Phase Use

Item	Model	Earth sensors for spin phase use	
		Laboratory model	Operational machine for ETS-V
Size (mm) (excluding optical protrusion)		128 x 122 x 104	148 x 122 x 104
Weight (kg)		1.12	1.26 ± 0.05
Power consumption (W)		2.34 max (when cold)	3.4 max
Measuring precision		0.1° ~ 0.340 (depending on using conditions)	Same as left
Infrared optical system	Infrared detector	Titanate pyroelectric element	Same as left
	Infrared filter	14 ~ 16 μm	Same as left
	Infrared condenser system	F/1.1, φ32	Same as left
	Instantaneous field-of-vision angle	1.5° ± 0.2°	Same as left
Resistance to environments	Allowable working temperature	-40°C ~ +70°C	-25°C ~ +55°C
	Random vibration	22.6G	22.7G
	Acceleration	20G	20G
	Impact	150G	150G

Research and development with emphasis on cyroelectric infrared detectors is being conducted to help Japan develop earth sensors of its own.

#### BIBLIOGRAPHY

1. Murakami, Tsutomu, "Attitude Control for Artificial Satellites and Sensors," SENSE GIJUTSU, Vol 3, No 2, 1983.
2. Walfe, William L., "The Infrared Handbook, Environmental Research Institute of Michigan," 1978.
3. Rose et al., H., "The Handbook of Albedo and Thermal Earthshine, Environmental Research Institute of Michigan," Ann Arbor, MI, Report No 190201-1-T, 1973.
4. Wertz, James R., "Spacecraft Attitude Determination and Control," D. Reidel Publishing Company, 1980.
5. Murakami, Tsutomu, Ikeuchi, Masami, et al., "Study on the Operation of Scan Type Earth Sensors for Satellite Borne Experiments, Report on Results of Joint Research," Aeronautical and Space Technology Research Institute and National Space Development Agency (Part 1 to Part 5), 1979-1983.
6. Wakabayashi et al., Y., "Analysis on IR Horizon Scanner Flight in a Transfer Orbit," AIAA Guidance and Control Conference, San Diego, Ca, 1982.

20,108/8918  
CSO: 4306/2509

AEROSPACE SCIENCES

SATELLITE 'SAKURA' TO BE DEACTIVATED

OW131053 Tokyo KYODO in English 1013 GMT 13 Nov 85

[Text] Tokyo, Nov 13 KYODO--The National Space Development Agency announced Wednesday that it will cease operating the experimental stationary satellite Sakura on 15 November, eight years after it was launched in the United States.

The Sakura has been used for the world's first test of superhigh frequency since it was launched into the stationary orbit some 36,000 kilometers over the Equator from the Kennedy Space Center in Florida on 15 December 1977.

The agency said it has decided to halt the operation of the satellite because it has run out hydrogen fuel for controlling its position.

It will be moved out of the stationary orbit with the remaining fuel, it said. The Sakura is the second stationary satellite to end its mission, following the experimental broadcasting satellite Yuri.

/7358  
CSO: 4307/002

AEROSPACE SCIENCES

AGREEMENT ON JOINT LIGHT AIRLINER REACHED WITH PRC

OW190437 Tokyo KYODO in English 0353 GMT 19 Nov 85

[Text] Tokyo, Nov 19 KYODO--Japan and China have reached basic agreement to jointly develop a 30-40 seater passenger aircraft by 1990, the Ministry of International Trade and Industry (MITI) said Tuesday.

The agreement, reached at working-level bilateral talks held in Beijing Monday, calls for China to manufacture about 600 turbo-propeller airliners based on a basic design to be produced by Japan, a MITI spokesman told reporters.

China has expressed the hope that Japan will sell about 300 planes to Southeast Asian countries, while China uses the rest for intercity transport, the official said.

A special committee of the Society of Japanese Aerospace Companies will send industry representatives to China at the end of this year to study the feasibility of the project.

The committee will also study the possibility of financing from the government-owned Japan Development Bank and Export-Import Bank of Japan as well as Chinese state financing, depending on its foreign reserves.

The project is part of China's seventh five-year economic modernization plan starting next year.

China proposed the project last August when a delegation of Japanese aerospace experts visited China.

/7358

CSO: 4307/002

AEROSPACE SCIENCES

NEW OSAKA AIRPORT PROJECT SPARKS TRADE FRICTION

OW190553 Tokyo KYODO in English 0534 GMT 19 Nov 85

[Article by Susan Moffat]

[Text] Osaka, Nov 19 KYODO--Japan's plan to build an international airport in Osaka with twice the capacity of Tokyo's Narita is designed to open up western Japan to the world, but is instead becoming the source of new trade friction.

The 1 trillion yen (about 5 billion dollars) project to build Japan's first 24-hour airport on a man-made island in Osaka Bay, scheduled to begin next year for completion in 1993, will be western Japan's largest construction and communications project in this half-century, and a model for the private operation of public facilities.

Foreign governments are clamoring for the airport to set up an open bid/tender system to make it easier for non-Japanese suppliers, but they're having trouble getting their own private sectors to make an effort to sell.

"We're open to buying imported navigation and communications equipment," Kansai International Airport Company President Yoshio Takeuchi, formerly of the Ministry of Transport, told KYODO News Service "but so far all we've heard is demands from governments, almost nothing from actual companies."

Foreign government officials say the companies are waiting for clearly announced specifications and the promise of an openly competitive tender system.

The pattern of this dispute, just beginning, is typical of many areas of Japan-U.S. trade friction.

American officials say they were deeply disappointed Kansai (Osaka region) International Airport Co. was not included in the government's "action program" for improving procurement procedures announced last July, which did include Nippon Telegraph and Telephone Corp. (NTT).

The airport, whose capital of 120 billion yen ranks it with Toyota Motor and Fujitsu, takes on a significance beyond its own runways as it may serve as a model for future massive privatizations, including the Japanese National Railways and Japan Air Lines.

Like the recently privatized NTT, it is a nominally private company, whose shares are held 2/3 by the government and 1/6 by local governments. (NTT's shares are still all held by the government).

But unlike NTT, the company has been "private" from the start though its staff of just 150 is drawn almost entirely from government ministries, with only five employees supplied by the private sector.

Also unlike NTT, foreign investors say they aren't particularly interested in buying shares because the first slim profits may not come for another 25 years, though Takeuchi predicts the operation will go into the black after just five years.

Osaka Corporations, however, are breaking down doors to buy stock. They offered 480 billion yen when only 200 billion yen in shares were allocated to the private sector, and the company is now discussing whether to increase that share.

Led by large enterprises such as Matsushita Electric, Sumitomo Metals, and Kansai Electric Power Co., the businessmen say they're investing out of civic duty and hopes of indirect benefits from the revival of the economically stagnating Osaka region, Japan's historical center of commerce and industry.

A shareholder's commitment to the project is also good for a company's chances of selling goods and services to the airport.

But foreigners are hopeful of getting a piece of the 880 billion yen debt-financing business the project will create. A company spokesman said "most of the major American and European banks" operating in Japan have made contact with the company.

Foreign airlines are also looking forward to increased business. The airport's 24-hour operation, allowing 160,000 takeoffs and landings a year, will give some of the 33 foreign airlines waiting to be granted access to Japan a chance to land in Osaka.

That will also increase the opportunity for Japanese airlines to land abroad through reciprocal agreements.

Asian trade, in particular, will be greatly aided by the increased capacity in Japan's traditional gateway to the south and west.

With the world's largest cargo capacity, the Kansai Airport hopes to get back for Japan business lost to airports in Singapore and Taiwan, and firmly establish Japan as the main air transfer point between Asia and the rest of the world.

Osakans hope the airport will attract high-tech business, international conferences, and win back the economic leadership that it has lost to Tokyo since World War II.

/7358  
CSO: 4307/002

AEROSPACE SCIENCES

FRENCH BUSINESSMEN URGE AIRCRAFT PURCHASES

OW071727 Tokyo KYODO in English 1025 GMT 7 Nov 85

[Text] Tokyo, Nov 7 KYODO--A group of French business leaders called on Japan to purchase passenger planes and helicopters in a meeting Thursday with Prime Minister Yasuhiro Nakasone.

Nakasone in turn suggested that French firms step up industrial cooperation with Japanese companies through technological and capital tie-ups, officials said.

Similar conversations took place between the French delegation, led by Yvon Gattaz, head of the National Confederation of French Employers (CNPF), and Foreign Minister Shintaro Abe and International Trade and Industry Minister Keijiro Murata in separate meetings.

The officials said Gattaz, the founder of the electronics maker Radial, complained of stumbling blocks to the entry of foreign enterprises into the Japanese market.

Nakasone requested Gattaz to draw up a list of such obstacles and produce it to the Japanese Government, the officials said after the meeting.

In response to the request for Japan to buy French aircraft, the Japanese premier said that purchases of aircraft are a matter for all Nippon Airways and other Japanese carriers to consider. He added that his government is currently working on easing regulations for setting up heliports in Japan, Japanese officials told reporters.

Nakasone also said that Japan's "action program" will give foreign products greater access to Japanese markets because of its radical quantitative and qualitative improvements.

Foreign Minister Shintaro Abe, meeting earlier in the day with the French business leaders, lamented that the European Community has failed to make a proper assessment of the market liberalization program, according to a ministry official.

Abe told the French group that Japan and the EC will hold top-level talks November 16-18 to strengthen their economic relations, the official said.

/7358  
CSO: 4307/002

AEROSPACE SCIENCES

MITI PUSHES PLAN TO DEVELOP ATP AIRCRAFT ENGINE

OW140603 Tokyo KYODO in English 0555 GMT 14 Oct 85

[Text] Tokyo, Oct 14 KYODO--The Ministry of International Trade and Industry (MITI) is pushing an industrial plan to jointly develop an advanced turbo-pro (ATP) engine, which MITI officials who announced this Monday call the aircraft engine of the 21st Century.

The ministry is encouraging a plan to establish a new firm as early as next spring along with five major aircraft-related Japanese makers, Mitsubishi Heavy Industries Ltd., Ishikawajima-Harima Heavy Industries Co., Kawasaki Heavy Industries Ltd., Fuji Heavy Industries Ltd. and Sumitomo Precision Products Co., the officials said.

The ATP engine, when developed, will be capable of mach 0.8, and be approximately 25 percent more fuel-efficient than the conventional turbo-fan type engine.

The engine will also use new materials to make it quiet and light-weight, and its development will involve research into engines, propellers and fuselages as well as electronics and other advanced technology the officials said.

The ATP engine, on which American and European makers, are also working, is expected to come into wide use by world aircraft makers after about 1995, they said.

MITI is planning to invest in the projected joint firm using funds from the newly-established Basic Technology Research Promotion Center, which it administers jointly with the posts and telecommunications ministry, the officials added.

/7358  
CSO: 4307/002

CHEMICAL ENGINEERING

FIBER REINFORCED PLASTICS DESCRIBED

Tokyo NIKKO MATERIALS in Japanese Jan 85 pp 85-96

[Article by the Industrial Survey & Research Department of Kagaku Sangyo Kaihatsu Co.: "Advanced Fiber Reinforced Plastics"]

[Excerpts] History of FRP Development

The development of fiber reinforced plastics (FRP) in Japan is said to date back to when some Japanese researchers undertook to analyze the structure of gasoline tanks from U.S. planes which carried protective plates for the tanks. But full-fledged research activity for the development of FRP did not come until around 1952. The FRP developed by Japanese researchers was first used in the manufacturing of helmets and corrugated plates. Around 1955, the FRP began to be utilized for the production of a wider range of products, such as boats, yachts, chairs, and dog-pulled sledges for use by Japanese scientists engaging in scientific observations in the Antarctic. In 1958, bathtubs were also added to the line of commercial FRP products and this helped popularize the name of FRP among Japanese consumers. By 1960, the kinds of products which were made with FRP had further expanded, and motorboats hulls and archery bows were also produced using FRP. In the years after 1960, FRP began to be used in the production of larger-sized products, such as tanks for purifying water (1961) and drinking water tanks set up atop towers or buildings. Parallel with the growth in the size of the products, a diversification in the production method of those FRP products was also taking place. FRP pipes and rods began to be manufactured using the drawing-molding method. Diversification in the production method also helped FRP in the manufacturing of a wider range of products.

During those years of development of new FRP products, a spectacular progress was made in molding FRP materials to produce FRP products. The molding method progressed from the hand lay-up molding to the "spray-up" molding (1959) to the hot press molding (1962), to the pre-form MMD molding (1967), to the SMC molding (1977). The development of these molding methods has contributed to the resultant progress of the FRP industry in Japan.

During those several years since 1965, the FRP industry in Japan achieved a spectacular market expansion. This expansion resulted mainly from substantial growth in the market of the FRP bathroom units for hotels and multi-story

apartments, the introduction of FRP into the hulls of fishing boats in building the vessels, and a sizable growth in the markets of other products such as water tanks, tanks to purify water as well as septic tanks for sewage systems, and various kinds of large-sized tanks and containers for other kinds of uses, with all of these tanks and containers made with FRP.

Figure 1. A comparison of specific tensile strength and specific elasticity rate between conventional materials and composite materials.

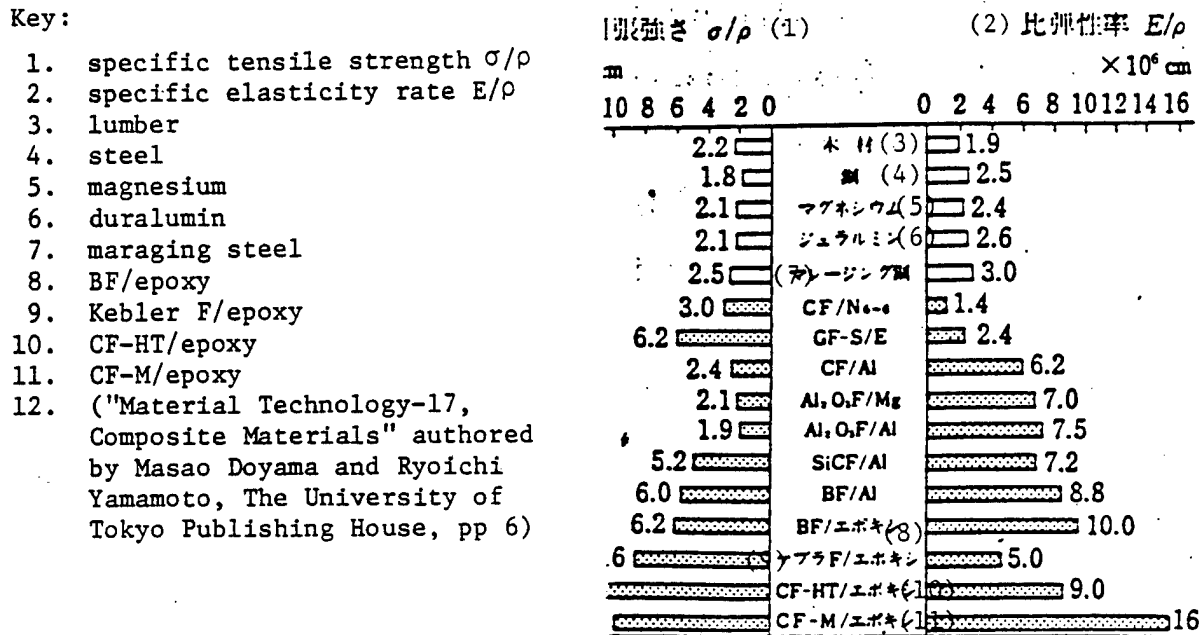

Figure 2. Classification methods of composite materials.

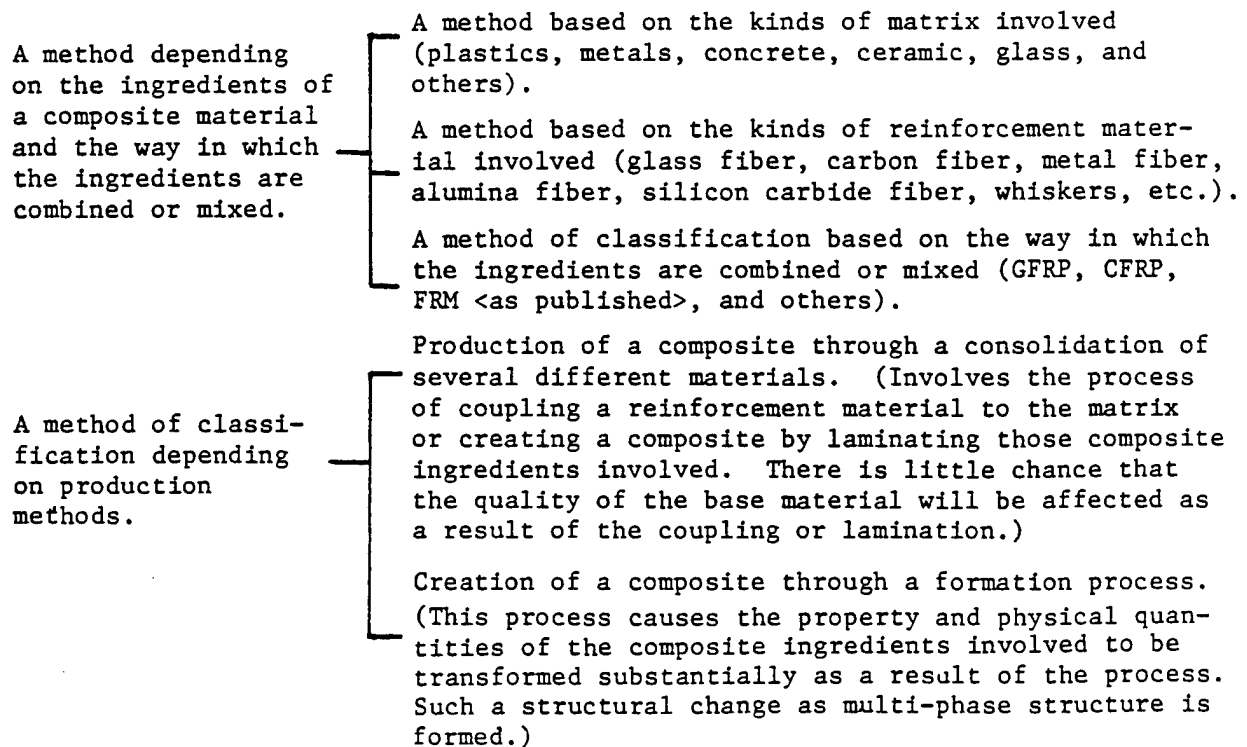
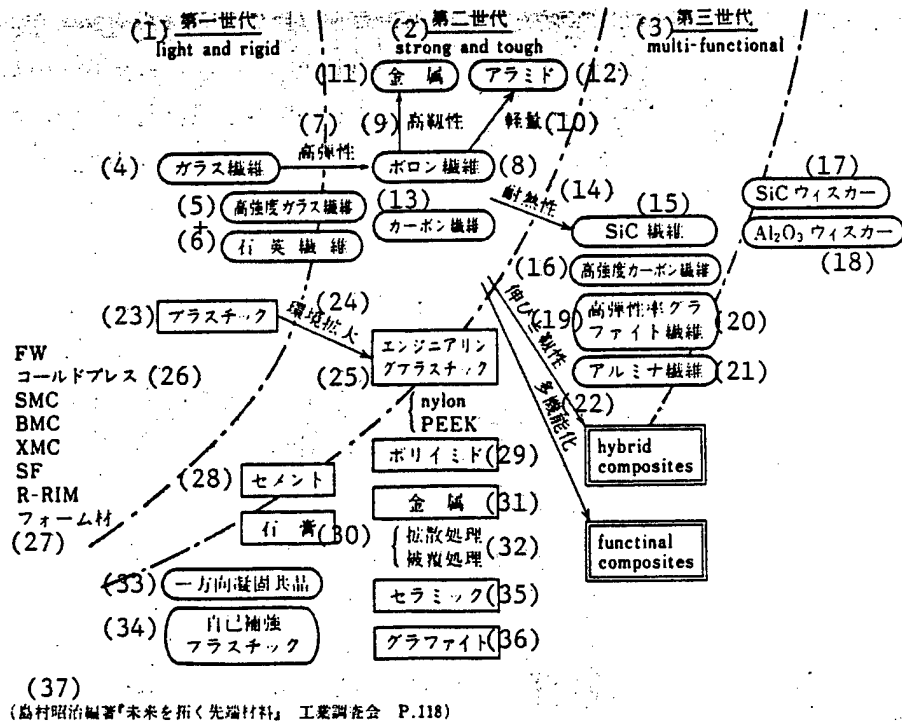

Table 1. Classification of matrix materials for the production of reinforced composite materials and of composite materials which are being manufactured utilizing those matrix materials.

Matrix materials	Composite materials
wood	plywood, laminated lumber, particle board, fiber board, wood-plastic composite material, wood-cement material
plastic	laminated film, artificial leather, foam material, electronic circuit substrate, hybrid material
metal	FRM (Fiber Reinforced Metal), PSM (Particle Strengthened Metal Alloy), DSM (Diffusion Strengthened Metal), one-way freezing eutectic alloy, magnetic composite material, functional composite material (wear-resisting alloy, electron collecting material, vibration absorbing ferrite plate, etc.
concrete	FRC (Fiber Reinforced Concrete), plastic concrete
ceramic and other inorganic materials	whiskers strengthened ceramic, ceramic foam, laminated glass, glass fiber reinforced carbon, gypsum composite material, optical fiber, foam glass

Figure 3. Development trends of composite materials.



Key on following page.

Figure 3 Key:

- |  |   |
|--|---|
| 1. 1st generation: light and rigid         | 21. alumina fiber   |
| 2. 2d generation: strong and tough         | 22. multi-functionalization   |
| 3. 3d generation: multi-functional         | 23. plastic   |
| 4. glass fiber                             | 24. expansion of applicable environs  |
| 5. high-strength glass fiber               | 25. engineering plastic   |
| 6. silica fiber                            | 26. cold press  |
| 7. high elasticity                         | 27. foam material   |
| 8. boron fiber                             | 28. cement  |
| 9. high toughness                          | 29. polyimide   |
| 10. light weight                           | 30. gypsum  |
| 11. metal                                  | 31. metal   |
| 12. Aramid                                 | 32. diffusion treatment, coating treatment  |
| 13. carbon fiber                           | 33. one-way freezing eutectic alloy   |
| 14. heat-resisting capability              | 34. self-strengthened plastic   |
| 15. SiC fiber                              | 35. ceramic   |
| 16. high-strength carbon fiber             | 36. graphite  |
| 17. SiC whiskers                           | 37. ("High-Tech Materials Under Development" authored by Shoji Shimamura, Kogyo Chosa Kai pp 118) |
| 18. Al <sub>2</sub> O <sub>3</sub>         |   |
| 19. toughness and extensibility            |   |
| 20. graphite fiber of high-elasticity rate |   |

The industry's shipments of its FRP products continued to increase steadily every year until they peaked at 190,000 tons in 1973. But the steady upward swing was abruptly interrupted due to the international oil crisis, and the domestic FRP industry was forced into a serious slump in shipment volume. Despite this, however, demand for FRP began to pick up gradually again in the years after the oil crises, particularly from the car manufacturing industry and the office automation equipment manufacturing industry partly as a result of the FRP industry's efforts to develop new fields of application for FRP. Now Japan's FRP industry is entering a period of sharp growth for the second time after the pre-oil crunch boom.

#### Materials for FRP Manufacturing

Table 3 is the classification of various kinds of materials used to manufacture FRP.

In the following sections of this article, we will describe the present state of progress in the development of different kinds of resins used as matrix material in the production of FRP and various other kinds of materials which are being utilized as reinforcement, and the features of those resins and reinforcement materials.

#### 1) Resin for FRP Production

The resins which are utilized in the production of FRP are divided into two major categories--thermoplastic resins and thermosetting resins.

Table 2. Matrix materials for the production of fiber reinforced plastic and development trends of reinforcing materials.

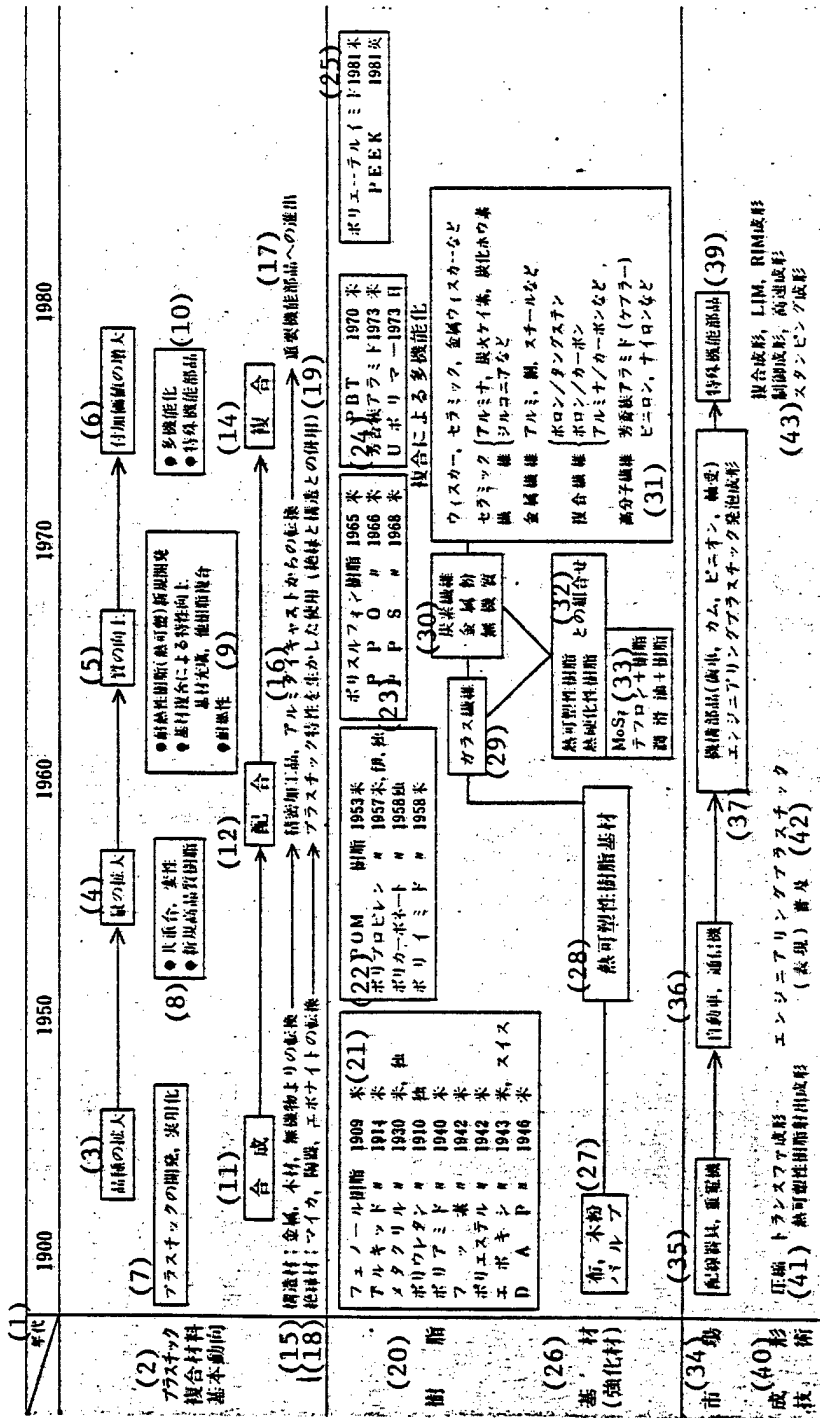

(株) 藤原工業 編 『精密機器用プラスチック材料』 日刊工業新聞社 P.21(44)

- Key:
1. years
  2. basic movement in development of composite plastic material
  3. expansion of product line
  4. quantitative expansion
  5. qualitative improvement
- [Key continued on following page.]
9. \* development of new heat-resisting resin (heat plasticization)
  - \* improvement of characteristics through introduction of reinforcement material, replenishment of composing materials, introduction of other kinds of resins
  - \* heat-resisting capability
6. increase of added value
  7. development of plastic and its practical application
  8. \* copolymerization, denaturation
  - \* new high-quality resin

Table 2 Key continued:

10.	* multi-functionalization				25.	polyether imide	1981 United States	
	* special function parts					PEEK	1981 Britain	
11.	synthesis				26.	reinforcement materials		
12.	mixing				27.	cloth, pulp, wood powder		
13.	--				28.	thermoplastic resin reinforcement material		
14.	compounding				29.	glass fiber		
15.	structural materials--metals, lumber, conversion from inorganic substance				30.	carbon fiber, metal powder, inorganic substance		
16.	precision-processed goods, conversion from aluminum die-casting				31.	* whiskers, ceramic, metal whiskers, etc.		
17.	advancement into category of useful functional parts					* ceramic fiber--alumina, silicon carbide, boron carbide, zirconia, etc.		
18.	insulator--mica, procelain, conversion of ebonite					* metal fiber, aluminum, copper, stainless steel, etc.		
19.	utilization, making use of features of plastic (as insulator as well as structural object)					* composite fiber--boron/tungsten, boron/carbon, alumina/carbon, etc.		
20.	resins					* polymer fiber--aromatic group Aramid (Kevlar, vinylon, nylon, etc.)		
21.	phenol resin	1909	United States		32.	combination of thermoplastic resin and thermosetting resin		
	alkyd resin	1914	United States		33.	MoS <sub>2</sub> , Teflon + resin, lubricant + resin		
	methacrylic resin	1930	United States, Germany		34.	market		
	polyurethane resin	1910	Germany		35.	wiring equipment, heavy electric machinery		
	polyamide resin	1940	United States		36.	automobile, radio communications equipment		
	boron resin	1942	United States		37.	mechanical parts (gear, cam, pinion, bearing), engineering plastic foaming		
	polyester resin	1942	United States		38.	--		
	epoxy resin	1943	United States, Switzerland		39.	special functional parts		
	DAP resin	1946	United States		40.	molding technology		
22.	POM resin	1953	United States		41.	compression, transfer molding, thermoplastic resin injection molding		
	polypropylene resin	1957	United States, Italy, Germany		42.	engineering plastic (popular expression)		
	polycarbonate resin	1958	Germany		43.	composite molding, LIM molding, RIM molding, controlled molding, high-speed molding, stamping molding		
	polyimide resin	1958	United States		44.	("Composite Plastic Materials for Application to Precision Equipment and Machinery" compiled by Seiki Gakkai, Nikkan Kogyo Shimibun, pp 2)		
23.	polysulfone resin	1965	United States					
	PPO resin	1966	United States					
	PPS resin	1968	United States					
24.	PBT	1970	United States					
	aramid group	1973	United States					
	Alamid							
	U polymer	1973	Japan					

Table 3. Classification of the materials constituting fiber reinforced plastic.

Materials constituting the plastic	Kind of material	Materials utilized
Matrix resins	Thermosetting resin	Unsaturated polyester resin, epoxy resin, phenol resin, vinyl ester resin, etc.
	Thermoplastic resins	Polyamide (nylon), polycarbonate, ABS resin
Reinforcing materials	Inorganic fiber	Glass fiber (GF), carbon fiber (CF), asbestos fiber
	Organic fiber	Vinylon fiber, acrylic fiber, polyamide
	Other kinds of reinforcing materials	Metal fiber, whiskers, composite fiber
Other kinds of materials	Filler, setting agent, promotional agent, parting agent	

Thermoplastic resins are the kind that either melts or hardens when heat is applied. Such resins either turn into a fluid state or change their original shape as a result of the heat applied. As resins in the category of thermoplastic resins, the representative ones are vinyl chloride resin, vinyl acetate resin, acrylic resin, polyamide, polyethylene, and fluoro-resin.

On the other hand, thermosetting resins are the kind that hardens above certain temperatures when they are subjected to heat. These resins permanently lose some of their physical features which they had before being heated. With such resins, once they have hardened as a result of heating, they never turn into a liquid state even if they are heated again. Phenol resin (bakelite), urea resin, melamine resin, unsaturated polyester resin, and epoxy resin are the representative resins in the category of thermosetting resins.

Usually thermosetting type resins are utilized mainly for the production of FRP.

#### (1) Unsaturated Polyester Resin

Unsaturated polyester resin contains unsaturated acid such as maleic anhydride or phthalic acid. By adding saturated polybasic acid such as phthalic anhydride and isophthalic acid, polyhydric alcohol such as propylene glycol and (or?) ethylene glycol are obtained. Unsaturated polyester resin is a resin in liquid form which can be obtained by dissolving polyhydric alcohol and unsaturated

alkyd, which can be produced by esterifying (what?), in the (solution?) of such polymeric monomer as styrene monomer.

As a method to set unsaturated polyester resin the radical polymerization method is being utilized. In this method, the setting is carried out by bridging unsaturated polyester resin with vinyl monomer like styrene. As catalysts used to promote the setting process, either naphthenic acid cobalt, dimethylaniline, or benzoyl peroxide is utilized depending on the temperature at which the setting takes place. In order to realize proper gelation time suitable for a particular method of molding of the resin, it is important to pay due attention to the temperature of the room where the setting is carried out and to the adjustments of the catalysts and the agents to promote the setting process to ensure maximum efficiency (translator's explanation).

In addition to the above-mentioned method for carrying out the setting of unsaturated polyester resin, there are also other methods available by which the radical molymerization is carried out. They involve the process of projecting either ultraviolet rays or radiation at the resin for setting. All of these methods have already been put into practical application.

The chemical features of unsaturated polyester resin have been found most suitable for the production of FRP. For this reason, this resin is the most popular among those being presently utilized in the production of FRP in Japan, and it is now used in about 90 percent of the total output of FRP in the country. In 1983, the production of unsaturated polyester resin stood at 190,000 tons, of which 70 percent was used for manufacturing FRP.

With the field of application of FRP expanding appreciably in recent years, users have increasingly been demanding a diversification in the characteristics of FRP so that they can choose the most suitable type of FRP for their application. In the following sections of this article, we will touch briefly on the recent movements in the industry.

#### (a) Making FRP Fire-Resistant

FRP's application fields include its usage as housing structure material, creating various housing-related equipment and facilities, and application in the field of transportation. The FRP to be utilized in these fields of application is naturally required to be fire-resistant.

Fire resistance in unsaturated polyester resin has been realized by adding or mixing with the resin substances such as halogen group elements, phosphorus compound, or inorganic fillers, including hydrate alumina. When inorganic fillers are utilized to impart fire resistance ability to unsaturated polyester resin, they are required to be added in relatively large dosages. Recently, a new method to make the resin fire-resistant has been utilized. The method calls for applying a layer of a certain kind of paint on the surface of FRP products. Such a coating produces an inert gas when it is exposed to fire, and this causes the formation of a foam layer which in turn works to protect the FRP products from fire by insulating them from the heat of fire.

(b) Corrosion-Resisting Resin

In recent years, demand for FRP to use in tank in supply systems of water for drinking and other purposes, for brewing tanks, pipes, and manufacturing other kinds of goods have been on the increase in Japan. When unsaturated polyester resin is used to produce these products, the resin is required to have good corrosion-resisting ability. It is expected that demand for the FRP which has a good anti-corrosion capability and weatherability would further increase in the future.

At present, there are a number of methods available to improve corrosion-resisting ability in unsaturated polyester resin. Those methods require reducing the coupling density of the ester involved, reducing or closing the end group, introducing hydrophobic type acid or hydrophobic type glycol, and making a careful choice of monomer.

Different kinds of unsaturated polyester resins which are quite corrosion-resistant have already been put on the market by several producers. They include a product tradenamed Derakane produced by Dow Chemical, Epocry II by Shell Chemical, and the products belonging to the epoxy acrylic resin category or vinyl ester resin category which are being manufactured by domestic makers such as Hitachi Chemical and other manufacturers.

On the other hand, as a resin having weatherability, the resin which contains an ultraviolet rays absorbent such as salicylate derivative, which imparts weatherability to resins, has been available on the market.

(c) Heat-Resisting Resin

Ordinarily, heat-resisting unsaturated polyester resin is manufactured by adding isophthalic acid to the resin. When phthalic anhydride acid was utilized as an additive instead, the breaking of the principal chains of the ester involved takes place when the resin containing it is heated, causing a sublimation of the phthalic anhydride acid. But when isophthalic acid is used, no such phenomenon can be observed.

(2) Epoxy Resin

At present, epoxy is the second most popular resin in use for the production of FRP.

Table 5. Resins used in the production of heat-resisting fiber-reinforced thermal plastic.

Resin Names	Material Characteristics	Tensile strength (kgf/cm <sup>2</sup> )	Elongation rate before tensile break (%)	Temperature of heat transformation (°C)
Polyamide-imide		2000	5.4	271
Polyether ether ketone		2150	3	300
Polyamide/bis-marimide resin		1000		320

Epoxy resin is a compound which has at least more than two epoxy groups within a single molecule. It is divided into glycygyl (phonetic) type epoxy resin and non-glycygyl type epoxy resin.

More than 90 percent of the epoxy resins currently being manufactured are of the bisphenol A glycygyl type. This type of epoxy resin constitutes the mainstay of the resins currently being utilized for the production of FRP.

To cause the setting of epoxy resin solution, there are three different methods employed by the manufacturers at present. They are the catalytic polymerization method, coupling method, and a method in which epoxy resin is caused to react as a polyohl (phonetic) with (what?).

In an effort to further improve the heat-resisting ability of FRP, research on novolak type epoxy resin for use in the production of FRP has been conducted by the industry. And the introduction of brominated epoxy resin is also under study for the production of fire-resisting FRP.

### (3) Vinyl Ester Resin (Epoxy Acrylate Resin)

Vinyl ester resin which can be created by causing bisphenol A glycygyl type epoxy resin and unsaturated basic acid to react with each other, displays particularly good chemical-resisting capability. This produces vinyl ester resin which is utilized increasingly today in the production of various equipment and facilities used for the prevention of environmental pollution. The only drawback of the resin used for those application is its high cost. Compared with unsaturated polyester, utilizing vinyl ester in the production of those equipment and facilities is much costlier. At present, the companies which are marketing vinyl ester resin include Dow Chemical, Shell Chemical, Showa Highpolymer, and Dainippon Ink and Chemicals.

### (4) Phenol Resin

The FRP which is produced using phenol resin is estimated to account for between 4 and 5 percent of the total FRP output. Phenol resin performs well in heat resisting, chemical-resisting as well as solvent-resisting. Among other advantages of this resin over other kinds of resins are its relatively low degree of degeneration in strength after the resin has been put into a boiling liquid for a certain length of time. However, phenol resin has disadvantages, too. The resin is brittle, takes longer for setting, and is not easy to color. At present, the resin is utilized primarily in the production of fishing rods, ski sticks, and pipes, among other products.

### (5) Other Kinds of Resins

The several kinds of resins described so far in this article account for a majority of thermosetting resins which are used in the production of FRP. Among other kinds of thermosetting resins which have not been mentioned are polybutadiene resin and silicone resin. Polybutadiene resin excels in corrosion-resisting and has good electrical characteristics. On the other hand, silicone resin is superior in strength and has good electrical insulating

capability. These features explain why both polybutadiene resin and silicone resin are utilized in special fields of application such as the electric and aircraft industries.

## 2) Resin for FRTP Production

The term "Fiber Reinforced Thermal Plastics" (FRTP) has been coined for a plastic to distinguish it from FRP which utilizes thermosetting resins as material in production.

In the development of FRP, the main goal of development has been to produce a plastic with better strength. In the case of FRTP, researchers have been aiming at making an improvement not only in its strength but also its heat-resisting ability as well as stability in dimension.

Ever since glass fiber reinforced polyamide was put into practical use in the industry in 1956, various kinds of FRTP have been developed so far and some of them have already begun to be utilized in practical application.

Today the market of FRTP has grown to the point where about 100,000 tons of the plastic is used per year. FRTP is being utilized primarily in the production of products such as cars, electric appliances and electronic parts. In many of these products, FRTP is employed as a substitute for aluminum.

Table 4 shows a number of resins which are mainly utilized for the production of FRPT.

## 3) Reinforcement Materials

As reinforcement materials for utilization in the production of FRP, the following ones are chiefly used at present. They are glass fiber, carbon fiber, metal fiber, synthetic fiber, natural fiber, asbestos fiber, boron fiber, ceramic fiber, and whiskers.

Table 6 gives a number of reinforcement materials in fiber form and their characteristics. Glass fiber is one of the reinforcement materials popularly utilized in the production of FRP. With respect to tensile strength, glass fiber displays a fairly high level among long fiber materials, which is only second to that of steel and boron fibers. But in terms of elasticity rate, glass fiber displays the lowest level. This means that when a certain degree of stiffness must be attained in glass fiber, the thickness of the fiber must be increased. This is a major drawback in using glass fiber as reinforcement material.

In contrast to glass fiber, carbon fiber has a higher degree of elasticity and it is lighter. Due to these advantages, carbon fiber has begun to be utilized as a reinforcement material in which are now available on the market. Though it is inferior to E-type glass fiber, C-type glass fiber fares better in acid-resisting capability, and this is why it is utilized in the FRP in the production of tanks for holding various kinds of chemical fluids. S-type glass fiber is utilized in the production of the FRP which is destined for usage in the military, space, and aircrafts due to its higher strength and higher elasticity.

Table 4. Thermoplastic resins utilized in the production of glass fiber reinforced thermal plastic.

(4) 樹脂名 (5) 樹脂	(2) 引張強さ (kgf/cm <sup>2</sup> ) 伸び (%)		(3) 熱変形温度 (°C)	
	ナチ (6) ラル	ナチ (6) ラル	ナチ (6) ラル	ナチ (6) ラル
PBT resin	560	1400	4	58
nylon 6	740	1900	5.8	55~58
nylon 6-6	780	1700	3	58~61
dematuralized PPO	550~675	1020	4	130
polycarbonate	560~670	1320	4~5	129~141
polyacetal	620	1300	3	110
polysulfone	710	1300	2	175
polyallylate (?)	670	1370	1.3	138
	730	1050	10	164

("Composite Plastic Materials for Application to Precision Equipment and Machinery" compiled by Seiki Gakkai, Nikkan Kogyo Shimbun, pp 45-46)

Key:

1. material characteristics
2. tensile strength (kgf/cm<sup>2</sup>), elongation (%)
3. temperature of heat transformation (°C)
4. resin names
5. distinction between natural and GFRTTP
6. natural

Table 6. Kinds of reinforcement fiber used in the production of fiber-reinforced plastics and their characteristics.

(1) 繊維の材料	(2) 径 (μm)	(3) 密度 (gf/cm <sup>3</sup> )	(4) 引張強さ (kgf/mm <sup>2</sup> )	(5) 比強さ (cm × 10 <sup>-6</sup> )	(6) 弾性係数 (kgf/mm <sup>2</sup> )	(7) 比弾性係数 (cm × 10 <sup>6</sup> )	(8) 最高使用温度 (°C)	(9) 特徴
(10) ガラス繊維								
Eガラス (11)	10	2.55	350	14	7400	290	700	原料の種類が多く、選定の範囲が広い。価格 (340~25000円/kg) (12)
高強度ガラス (S994) (13)	10	2.49	460	18	8800	350	840	軍艦用、航空宇宙開発など特殊な用途に用いる。価格が高い。 (14)
高弾性ガラス (YM-31A)	—	2.89	350	12.2	11200	390	—	比弾性が要求される用途に用いる。現在、価格が高い (5~10万円/kg) が将来下がる可能性がある。 (17)
(15) 炭素繊維								
多結晶質繊維								
炭素繊維 (米国品) (16)	7~10	1.58	180	11	28100	1780	3650	試作品 (19)
アルミナ (Al <sub>2</sub> O <sub>3</sub> ) (18)	8~10	1.91	220	12	43600	2280	3650	主に航空宇宙開発関係の用途。複雑な形状の成形には不適 (22)
アルミナ (ZrO <sub>2</sub> ) (18)	—	3.16	210	6.6	17600	560	2040	樹脂強化には、現在用いられていない。 (25)
シリコニヤ (20)	—	4.84	210	4.3	35100	730	2650	繊維が粗いのが欠点で補強効果が悪い。樹脂強化には実用化されていない。 (28)
ボロン/タンタム/タングステン (21)	102	2.63	280	11	38600	1470	2300	試作品 (19)
炭化ケイ素/タンタム/タングステン	102	3.46	210	6.1	47100	1360	2690	主に航空宇宙開発関係の用途。複雑な形状の成形には不適 (22)
(23) 金属繊維								
タンタム	13	19.3	410	2.0	41500	220	3400	樹脂強化には、現在用いられていない。 (25)
モリブデン	25	10.2	220	2.3	36600	360	2620	樹脂強化には、現在用いられていない。 (25)
銅	13	7.75	420	5.3	20400	260	1400	樹脂強化には、現在用いられていない。 (25)
ベリリウム	127	1.83	130	7	24600	1350	1280	樹脂強化には、現在用いられていない。 (25)
セラミック								
セラミック (26)								
アルミナ (Al <sub>2</sub> O <sub>3</sub> )	3~10	3.96	210	53	43800	1100	2040	樹脂強化には、現在用いられていない。 (25)
炭化ケイ素 (SiC) (27)	<1~3	3.21	210	66	49200	1540	2690	樹脂強化には、現在用いられていない。 (25)
窒化ケイ素 (Si <sub>3</sub> N <sub>4</sub> )	—	3.18	1410	44	38700	1210	1900	樹脂強化には、現在用いられていない。 (25)
金属								
鉄	—	7.83	1340	17	20400	260	1540	樹脂強化には、現在用いられていない。 (25)
ニッケル (30)	—	8.97	390	4.3	21800	240	1450	樹脂強化には、現在用いられていない。 (25)
ケブラー 49	12	1.45	370	25.5	13400	920	260	比弾性が要求される用途には有効。価格 (2000~50000円/kg) (33)
ケブラー 29 (32)	—	1.44	280	19.5	6500	440	262	比弾性が要求される用途には有効。価格 (2000~50000円/kg) (33)
(31) 合成繊維								
ポリエステル								
ビニロン (34)	—	0.91	35~100	—	200~2000	—	—	耐衝撃、耐摩耗、耐食性を要求される用途に用いる。 (35)
ナイロン	—	—	—	—	—	—	—	耐衝撃、耐摩耗、耐食性を要求される用途に用いる。 (35)
ポリプロピレン	—	1.39	—	—	—	—	—	耐衝撃、耐摩耗、耐食性を要求される用途に用いる。 (35)
(36) 天然繊維								
アスベスト	0.03	2.4~2.6	56~70	—	—	—	493°Cで結晶水放出 (38)	耐衝撃、耐摩耗、耐食性を要求される用途に用いる。 (35)
クリソタイル (37)	~0.17	3.2~3.3	11~120	—	—	—	—	耐衝撃、耐摩耗、耐食性を要求される用途に用いる。 (35)
アモサイト (37)	—	—	—	—	—	—	—	耐衝撃、耐摩耗、耐食性を要求される用途に用いる。 (35)
綿 (40)	12~38	1.0~6.0	—	—	—	—	—	安価である。低価格FRPに使用 (41)

(情報学会編「精密機器用プラスチック複合材料」 日清工業株式会社 P.28) (42)

Key:

1. kinds of reinforcement fiber
2. diameter of fiber ( m)
3. density (gf/cm<sup>3</sup>)
4. tensile strength (kgf/mm<sup>2</sup>)
5. specific strength (cm x 10<sup>6</sup>)
6. modulus of elasticity (kgf/mm<sup>2</sup>)
7. specific modulus of elasticity (cm x 10<sup>6</sup>)
8. maximum usable temperature (degrees C)
9. features
10. glass fibers
11. E-type glass
12. Many kinds of materials in glass production are available and this offers a list of a wide variety of materials from which the manufacturers can choose. Prices of the materials range from ¥340 to ¥2,500 per kilogram.

[Key continued on following page.]

Table 6 Key continued:

13. high-strength glass (S994), high-elasticity glass (YM-31A)
14. Used for special applications such as in the military, aircrafts and space. Price is high.
15. polycrystalline fiber
16. carbon fiber (made in the United States) (made in Britain)
17. Utilized where specific stiffness is required. At present, price is high, ranging from ¥50,000 to ¥100,000 per kilogram of the material. But there is a possibility that the price will go down somewhat in the future.
18. alumina ( $Al_2O_3$ ), zirconia ( $ZrO_2$ )
19. experimentally created fibers
20. composite fiber
21. tungsten/boron, silicon carbide/tungsten
22. Principally aimed for use in aircrafts and space. Unsuitable in applications requiring those fibers to be molded into complex shapes.
23. metal fiber
24. tungsten, molybdenum, stainless steel, beryllium
25. At present, metal fibers are not being utilized in resins for the purpose of reinforcement.
26. ceramic whiskers
27. alumina ( $Al_2O_3$ ), silicon carbide (SiC), silicon nitride ( $Si_3N_4$ )
28. The drawback of ceramic whiskers is that they are not good reinforcement material due to shortness of their fiber length. The whiskers are not utilized for reinforcement purpose in resins on a commercial basis.
29. metal whiskers
30. iron, nickel
31. synthetic fiber
32. Kevlar 49, Kevlar 29, (polyamide system)
33. Expected to be a promising reinforcement fiber when a specific stiffness is required. Prices range from ¥2,000 to ¥50,000 per kilogram.
34. vinylon, nylon, polypropylene
35. Utilized where shock-resisting, wear-resisting as well as corrosion-resisting abilities are required
36. natural fiber
37. asbestos, (chrysotile), (amosaito <phonetic>)
38. Emit water of crystallization at  $493^\circ C$ .
39. Suitable where abrasion as well as corrosion-resisting capability are required. Cost is low.
40. cotton
41. Cost is low. Utilized as a reinforcement material in low-priced fiber-reinforced plastic.
42. ("Composite Plastic Materials for Application to Precision Equipment and Machinery" compiled by Seiki Gakkai, Nikkan Kogyo Shimbun, p 28)

In addition to these glass fibers, new types of glass fiber which have an alkaline-resisting ability and are regarded as suitable for the reinforcement of cement products, are being developed. To impart alkaline-resisting capability, those new types of glass fiber contain zirconia and  $SiO_2-ZrO_2-R_2O$ .

Table 7. Glass contents in glass fiber.

(2) (単位: %)

(1) 種類と特長用途	SiO <sub>2</sub>	Al <sub>2</sub> O <sub>3</sub>	Fe <sub>2</sub> O <sub>3</sub>	CaO	MgO	B <sub>2</sub> O <sub>3</sub>	Na <sub>2</sub> O	K <sub>2</sub> O	Li <sub>2</sub> O	BeO	TiO <sub>2</sub>	ZrO <sub>2</sub>	CeO <sub>2</sub>	F <sub>2</sub>
(3) E種(アルカリ電気絶縁用)	54.0	15.0		17.0	5.0	8.0	0.6							
(4) C種(化学用)	65.0	4.0		14.0	3.0	5.0	8.0	1.0						
(5) A種(含アルカリ一般用)	72.0	0.6		10.0	2.5		14.7							
(6) S種(高強度)	65.0	25.0			10.0									
(7) YM-31-A(高弾性)	53.7		0.5	12.9	9.0				3.0	8.0	8.0	2.0	3.0	
(8) ガラス綿用	59.0	4.5		16.0	5.5	3.5	11.0	0.5						
(8) ガラス綿用	59.5	5.0				7.0	14.5				8.0	4.0		2.0

(9) (村山宏著「FRP成形加工技術」 工業調査会 P.96)

Key:

- |  |  |
|--|--|
| 1. Kinds of glass fiber features, and application fields | 6. S-type (high mechanical strength)   |
| 2. unit: percent   | 7. YM-31-A (high elasticity)   |
| 3. E-type (for alkaline electric insulation)             | 8. for production of glass cotton  |
| 4. C-type (for chemical application)                     | 9. "Technology for Molding and Processing of Fiber-Reinforced Plastic" authored by Hiroshi Murayama, Kogyo Chosa Kai, p 96 |
| 5. A-type (for general application involving alkali)     |  |

The features of glass fiber are as follows: (1) It has a very high tensile strength value and the strength increases as it becomes finer. (2) It excels in shock-resisting capability for it exhibits high strength and has a high extension rate within the breaking elasticity limits. (3) It has a very high elasticity rate and has no yield point. (4) Glass fiber is heat as well as fire-resistant and its strength is not affected up to a temperature of about 200°C. (5) The fiber exhibits good chemical resisting ability, except for boron and hot concentrated phosphoric acid. (6) In glass fiber production, the fiber length can be freely adjusted, and short as well as long fibers can easily be produced. (7) Glass fiber poses almost no health hazard to the human body.

When using glass fiber as reinforcement material in the production of FRP, the fiber must be treated first on the surface with the surface treatment agent in order to improve bonding between the fibers and the resins utilized for production of FRP.

(2) Carbon Fiber

Carbon fibers are divided into categories as shown in Table 8 (Table omitted). According to the table, first, carbon fibers are divided into high-performance type centering on PAN system fibers and general-purpose type centering on pitch system fibers. The high-performance type is further divided into highly tough type and highly elastic type.

Today it is estimated that the total world production of carbon fiber stands at around 2,000 tons per year. Of this production figure, the PAN system

fibers account for about 80 percent and the balance is the pitch system fibers. In Japan, Toray Industries, Toho Rayon and Kureha Chemical Industry form the top three producers. As they manufacture on such a large scale, the three Japanese producers control nearly 70 percent of the international market of carbon fiber. In terms of production capability, Japanese producers have a combined capacity of 2,850 tons per year, about three times that of the U.S. which stands at around 1,050 tons per year. It is expected that Japanese manufacturers will continue to lead other countries in production volume of carbon fibers in the coming years.

### (3) Boron Fiber

The development of boron fiber started in the United States around 1960. In 1966, the fiber began to be practically utilized as structural material in aircraft production. In recent years, boron fiber has been introduced into fishing rods and golf club shafts, and the fiber is attracting increasing attention from the industry because of its promising usefulness.

The boron fiber utilized in these products is made by vapor coating 12  $\mu$ m tungsten fiber with boron chloride or boron obtained by thermally decomposing organo boron, thus making the fiber vapor-coated into long fiber with a diameter of 0.1 mm. Boron fiber's strength is as high as three times that of carbon fiber. But it is heavier, hard, and snaps relatively easily. It is difficult to make a curved surface in products using boron fiber. The cost in producing boron fibers is about twice that of carbon fiber. For these reasons, it is expected that the application fields of boron fiber will be relatively limited.

### (4) Alumina Fiber

Alumina fiber is produced by either treating alumina at high temperature or by applying a special treatment to turn it into polycrystalline fiber. The principal feature of alumina fiber is its very high heat-resisting capability which ranges from 1,300 to 2,000°C. In terms of strength, alumina fiber is inferior to carbon fiber, but it possesses better electric insulation capability. Due to these characteristics, it is utilized in the production of a kind of FRP which is beginning to be used in space and military applications. Research has been under way in an effort to introduce alumina fiber also into car production. Alumina fiber is regarded as one of the promising kinds of fibers as reinforcement material in the production of FRP. In Japan, the makers engaged in the manufacturing of alumina fiber include Denki Kagaku Kogyo which produces the short fiber and Sumitomo Chemical which turns out long fiber.

### (5) Silicon Carbide Fiber

Silicon carbide fiber dubbed "miracle fiber" was originally developed by a professor at the state-run Tohoku University. Silicon carbide fiber can be obtained in uninterrupted form from the production system by polymerizing organic silicon compounds, melt-spinning the polymerized compounds, and then firing the spun object.

Silicon carbide fiber thus created is stronger than piano wire and has better high temperature characteristics than carbon fiber with a heat-resisting capability of up to 1,300°C. In addition to these advantages, silicon carbide fiber was good wettability with metals. Because of these features, it is utilized mainly as reinforcement material for metals. Research has been under way to make it possible to utilize silicon carbide fiber in ceramic and in resins as their reinforcement material.

Nippon Carbon is completing building its production facilities which would ultimately have a production capacity of 10,000 tons per month. The company is aiming to launch a full-scale commercial production of silicon carbide fiber for the first time in the world.

Meanwhile, Tokai Carbon, another of major Japanese reinforcement fiber maker, has succeeded in the development of whiskers.

#### (6) Organic Fiber

Alamid fiber developed by Du Pont of the United States has been gaining increasing attention within the industry in Japan as a substitute organic fiber which could be utilized to replace natural fiber and regenerated fiber like rayon.

In Japan, it is said that Teijin has embarked on a program to use this fiber as reinforcement material in some products on a commercial basis using its own technology.

#### (7) Steel Fiber

Among metal fibers are steel fiber and aluminum fiber. Details on these metal fibers will be disclosed possibly in future articles we may contribute to this publication Nikko Materiary, when we will be given such an opportunity again in the future.

#### Present Situation in FRP Development

As described in the preceding sections of this article, FRP is a composite material which is made up of the matrix resins and the reinforcement fibers. By changing the composition between the resins and reinforcement fibers, different kinds of FRP can be manufactured. However, only a few of those have been put into practical use. Among those being utilized now, only three kinds of FRP--GFRP, GFRTF, and CFRP--account for a majority of Japan's FRP market.

In the following sections, we will discuss the current situation in the development of FRP products and their application fields. At the same time, the recent situation in the development of advanced FRP products will also be discussed.

1) GFRP

Glass Fiber Reinforced Plastic (GFRP) was developed first among reinforced plastic products. GFRP accounts for most fiber reinforced plastic products whose production volumes are listed in various trade papers under the product name FRP. As for the matrix resin in the production of GFRP, it is estimated that unsaturated polyester resin counts for more than 90 percent of those resins utilized in the production of FRP. However, recently other GFRP products with epoxy resin as the matrix material have also begun to appear on the market.

Table 9. Kinds of glass fiber reinforced plastic.

Materials	Form of glass as a reinforcing material	Resins	Contents of glass (weight percent)
hand lay-up mold	chopped (glass?) mat, cloth	polyester polyester	30-40 45-55
spray up molding	roving	polyester	30-40
perform, mat, matched die molding	{ roving, chopped mat	polyester	30-50
premix molding, including BMC	{ roving, chopped (glass?) strand	{ polyester, epoxy, melamine, phenol, silicone	10-45
prepreg molding	cloth		50-65
SMC molding	{ roving, chopped mat	polyester	29-36
drawing molding	roving	polyester epoxy	50-80
filament winding molding	roving	polyester epoxy	60-90

("Technology for Molding and Processing of Fiber Reinforced Plastic" authored by Hiroshi Murayama, Kogyo Chosa Kai, p 106)

Regarding the production method of FRP, there are traditional methods such as the hand lay-up method which involves lamination work by hands, and the spray-up method in which blowing by a spray gun is involved. In recent years, new mechanical GFRP molding technology has been introduced and the producers are using those new molding methods by choosing the most suitable for particular GFRP products they are going to manufacture. Those molding methods are: the cold press method in which the molding is carried out using the press; the resin ink jet method in which a resin in liquid form is injected into a mold filled with reinforcement glass fibers; the matched die method in which the molding is carried out by applying heat and pressure to the GFRP production materials which are placed into a metal mold; the continuous drawing method; the continuous panel molding method for the production of corrugated as well as flat-surfaced plates; and the filament winding method. The matched die method is further divided into the MMD method, SMC method, and the BMC method.

Among the varied methods used today in the production of GFRP, the hand lay-up method is still the most popular. However, considering the fact that until 4 or 5 years ago about 60 percent of GFRP production had been carried out using this method, but today the ratio has declined appreciably, this indicates that automation and introduction of mechanical molding machines have made progress in the industry in the past several years.

## 2) CFRP

The practical application of CFRP to a number of commercial products started around 1973 when the carbon fiber reinforced plastic began to be utilized for the production of sports and leisure items such as skis, tennis rackets, golf clubs, and fishing rods. The industry's efforts to develop new fields of application of CFRP stepped up since the early 1980's.

As carbon fibers utilized for the production of CFRP, the fibers belonging to PAN system are most popularly used at present. Those carbon fibers are being utilized for reinforcement after being processed as prepreg, cloth, filament winding, or spread roving.

Table 11 lists the kinds of resins which are being utilized as matrix material for the production of GFRP [as published].

As shown in Table 10, the advantages of CFRP over other kinds of fiber reinforced plastics are its light weight, high mechanical strength, relatively strong stiffness, good wear-resistance capability, good characteristics in electric conductivity, x-ray penetrability, and good corrosion-resisting ability. The CFRP's light weight results from the relatively low density of materials composing it. The high mechanical strength means that CFRP also excels in tensile strength, and the CFRP's strong stiffness has something to do with its high elasticity rate.

Table 10. Characteristics of fiber reinforced plastic as a typical composite material.

(1) 種 類	(2) アルミナ (Al <sub>2</sub> O <sub>3</sub> )	(3) シリコンカーバイド <sup>2)</sup>	炭(4)素	(5) ガラス	
(6) 引張強さ (kg·mm <sup>-2</sup> )	260	250	280	180	
(7) 弾性率 (t·mm <sup>-2</sup> )	25	18	23	7.4	
(8) 繊維径 (μm)	9	10	7	10	
(9) 表面処理	(10) 処理せず	(10) 処理せず	(11) 理	(10) 処理せず	
	FRP	AFRP	SFRP	CFRP	CFRP
(12) 密度 (g·cm <sup>-3</sup> )	2.4	2.3	1.5	2.0	
(6) 引張強さ (kg·mm <sup>-2</sup> )	170	110	150	120	
(7) 弾性率 (t·mm <sup>-2</sup> )	13	10	13	4.5	
(13) 曲げ強さ (kg·mm <sup>-2</sup> )	180	160	170	120	
(14) 圧縮強さ (kg·mm <sup>-2</sup> )	150	160	110	46	
(15) 層間せん断 (kg·mm <sup>-2</sup> )	10	10	8~13	10	

注: 1) 住友化学, 2) 日本カーボン(ニカロン電) (16)  
 東京大学出版会 P.72

[Key on following page.]

Table 10 Key:

- |  |  |
|--|--|
| <ol style="list-style-type: none"> <li>1. kind of fiber</li> <li>2. alumina (Al<sub>2</sub>O<sub>3</sub>)*</li> <li>3. silicon carbide**</li> <li>4. carbon</li> <li>5. glass</li> <li>6. tensile strength (kg·mm<sup>-2</sup>)</li> <li>7. elasticity rate (t·mm<sup>-2</sup>)</li> <li>8. diameter of fiber (μm)</li> <li>9. surface treatment</li> <li>10. not treated</li> <li>11. treated</li> <li>12. density (g·cm<sup>-3</sup>)</li> </ol> | <ol style="list-style-type: none"> <li>13. bending strength (kg·mm<sup>-2</sup>)</li> <li>14. compressive strength (kg·mm<sup>-2</sup>)</li> <li>15. interlayer shearing (kg·mm<sup>-2</sup>)</li> <li>16. ("Material Technology-17, Composite Materials" authored by Masao Doyama, The University of Tokyo Publishing House, p 72)</li> </ol> <p>* Sumitomo Chemical Co, Ltd<br/>         **Nicalon (phonetic) by Nippon Carbon Co, Ltd</p> |
|--|--|

Table 11. The matrix resins utilized for the production of glass fiber reinforced plastic (GFRP).

Resin types	Production method of FRP	Names of resins utilized
Thermosetting resin (GFRP)	Prepreg	Epoxy (mainstay resin), unsaturated polyester, vinyl ester, polyimide
	SMC	Epoxy, unsaturated polyester, vinyl ester
Thermoplastic resin (GFRTIP)	Prepreg	Polyether sulfone, polyester, polyether ether ketone
	Injection molding	Nylon 6, nylon 66, PBT, polycarbonate, ABS, PPS, and others

Due to these merits of CFRP, it has been used in a wide range of products and the application fields are expected to expand still further in the future. Table 12 gives the names of products in which CFRP has already been introduced. CFRP is now one of the high-tech industrial materials which have a promising future in their prospective usefulness as new industrial material.

### 3) FRTIP

FRTIP first came into being after FRP belonging to the polyamide system was developed in 1956.

As mentioned in the previous passage of this article, an FRP which has been produced using thermoplastic resins (TP) as matrix material is called FRTIP. As reinforcement material, glass fiber is being utilized most widely at present. But carbon fiber and metal fibers are also being employed.

At present, a number of companies are engaged in the production of fiber reinforced plastics on a commercial basis with the combinations of the matrix resins and the kinds of reinforcement materials varying from producer to producer. Toray Industries is producing polyamide and imide, ICI is manufacturing PPS and PEEK, and Mitsui Petrochemical Industries is making polyamide bismarimide resin.

F RTP combines the features of thermoplastic resins and those of glass fiber or carbon fiber, depending on which of the reinforcement materials is utilized. Compared with metals, thermoplastic resins have an advantage in specific gravity, corrosion-resisting capability, and electric insulation ability. But thermoplastic resins are inferior to metals in mechanical strength, stiffness, and heat-resisting capability. Consequently, F RTP which incorporates either glass fiber or carbon fiber as reinforcement material, displays mechanical strength which matches that of metals and, at the same time, exhibits overall features which surpass those of metals.

At present, F RTP is used in the production of car transporting vehicles in parts of the vehicles such as the exterior surface, inside walls of the compartments, and the engine rooms. Reinforced plastic is also being used to produce mechanical parts and electric as well as electronic parts.

#### 5) Other FRP Products

As for high-tech FRP, there are hybrid FRP, Metal Fiber Reinforced Plastics (MFRP), Boron Fiber Reinforced Plastic (BFRP), and Aramid Fiber Reinforced Plastic (AFRP).

##### (1) Hybrid FRP

Hybrid FRP employs a combination of glass fiber and carbon fibers as reinforcement material. Depending on the way the reinforcement material is combined with matrix resins, hybrid FRP is divided into the so-called in-layer type and inter-layer type. As the matrix resin, epoxy resin is utilized the most at present. Hybrid FRP is deemed suitable for use in applications where good material involved are required, such as in building construction, marine application, and the production of various industrial members.

##### (2) MFRP

MFRP is one kind of fiber reinforced plastics in which metals fibers such as stainless steel fiber or aluminum fiber is utilized as reinforcement material.

Stainless steel fiber reinforced plastic has been developed to produce car brake pads as a substitute for asbestos pads. In addition to this, other kinds of MFRP have been developed in which a combination of aluminum fiber and glass fiber is employed as reinforcement material to create an MFRP with good thermal conductivity. Aisin Seiki is producing this kind of MFRP. An MFRP which carries a metal filler is being developed, which combines the features of resins and metals, including electric conduction capability. The development of this MFRP will be further stepped up in the future.

Table 12. Application fields of carbon fiber reinforced plastic (CFRP) composite material.

Features	Application Fields
light weight high elasticity rate high mechanical strength	Space and aircrafts, automobiles, textile industry machinery, fly-wheels, centrifugal separators, sports and leisure articles (golf clubs, angling rods, tennis rackets), tools and equipment
dimension stability	Space industry application (transponder antenna, etc.), micrometer, timing belt, ruler
vibration absorber	Audio equipment, musical instruments, driving shafts in automobiles, leaf springs, leisure equipment and facility
electrical characteristics (heat generation, prevention of static electricity)	Brewing tank, plastic molding facility, static electricity prevention material, motor brush, electrode
corrosion resisting capability	Chemical plant, collector electrode
wear-resisting ability	Bearing, brush material
x-ray penetrability	X-ray photographic plate cassette, medical x-ray bed
heat-resisting capability	Rocket parts, turbine engine parts, brake disc for aircrafts

("Material Technology-17, Composite Materials" authored by Masao Doyama, The University of Tokyo Publishing House)

Table 13. Production volume of fiber reinforced thermal plastic.

(3) (単位 トン)

(1) 樹脂名	(2) 用途分類				(8) 計
	(4) 輸送機械	(5) 電機電子	(6) 機械	(7) その他	
ポリアミド (9)	2,220	2,200	563	136	5,119
ポリアセタール (10)	646	590	100	0	1,336
ポリカーボネート (11)	108	1,996	647	383	3,134
P E T 系 (12)	450	2,100	300	0	2,850
P B T (13)	1,402	4,232	635	128	6,397
ポリプロピレン (14)	14,268	5,043	366	7,193	26,870
A S 樹脂 (15)	4,280	1,385	5	1	5,671
A B S 樹脂 (16)	24	990	505	46	1,565
その他 (17)	9	498	49	0	556
(8) 計	23,407	19,034	3,170	7,887	53,498

[Key on following page.]

(通産省、昭和53年度高機能樹脂需要構造調査報告書より) (17)

Table 13 Key:

1. resin names
2. classification in accordance with application field
3. unit: ton
4. transportation machinery
5. electric & electronic fields
6. machinery
7. others
8. total
9. polyamide

10. polyacetal
11. polycarbonate
12. PET system
13. polypropylene
14. AS resin
15. ABS resin
16. others
17. The features in this table are based on a report on demand for highly functional resins in fiscal 1978, which was announced by the Ministry of International Trade and Industry.

FRP Market Outlook

To conclude this article, we will refer briefly to the expected trend in the FRP market in Japan.

In Japan, the production of FRP started in the latter part of the 1950's. Full-scale manufacturing by the industry did not come until around 1969. In 1973, during which year high economic growth rates in Japan peaked, the domestic production volume of FRP totalled 200,000 tons and the shipment volume stood at 190,000 tons. However, during the following 2 years, the shipment volume of FRP continued to decline due to the adverse effects of the international oil crisis, and shipment of the plastic bottomed out in 1975. In that year, the shipment volume stood at only 60 percent of the peak production year which the industry experienced years ago. But in the years after 1976, shipment of FRP began to pick up again, and then the growth has continued, supported by an expansion of the market and the industry's efforts to develop new markets. In 1978, the shipment volume of FRP surpassed 200,000 tons, and in 1983, shipment increased to a record 250,000 tons.

However, compared with the level of demand for FRP in foreign countries, FRP demand in Japan is still considerably low and because of this, it seems there still is room for more growth of the FRP market in the country in the coming years.

But it must be noted that the production figures mentioned above were confined to the GFRP utilizing unsaturated polyester resin as the matrix material. When the FRP utilizing other kinds of resins is included, production figures rise up to 330,000 to 340,000 tons per year.

These estimated production figures have been reached partly from calculations which were made assuming that yearly production of FRTP, which is believed to be only second to GFRP in production volume, has lingered at a range between 70,000 and 80,000 tons in the recent past. The estimation of yearly output of FRTP at present was based on the data announced by the Ministry of International Trade and Industry (MITI) in fiscal 1978 which estimated the domestic production of the plastic at 54,000 tons per year then. In doing the calculation, the yearly production figure of 70,000 to 80,000 tons of FRTP was adopted assuming that the production of the plastic has continued to grow since the MITI announced

the data. At the same time, the overall production of FRP of about 340,000 tons per year was also reached by deducing it from an estimated domestic shipment volume of CFRP in the recent past, which is expected to stand around 600 tons per year.

20,102/8918  
CSO: 4306/1107

ENERGY

MITI SEES 'PERCEPTION GAP' ON COOK INLET OIL

OW020035 Tokyo KYODO in English 0017 GMT 2 Nov 85

[Article by Sei Ogawa]

[Text] Tokyo, Nov 2 KYODO--A high official of the Ministry of International Trade and Industry (MITI) said Saturday there is apparently a "perception gap" between the United States and Japan on the lifting of an export ban on Alaska's Cook Inlet crude oil.

The Agency of Natural Resources and Energy official said that the U.S. government has officially said there is no precondition attached to a Presidential order to start exporting Cook Inlet crude.

But there is a Congressional move afoot in Washington to demand increased imports of agricultural and other products from the U.S. by Japan in exchange for lifting an export ban on the American crude, said the official who declined to be named.

U.S. President Ronald Reagan also told Japanese Prime Minister Yasuhiro Nakasone in a meeting late last month in New York when he informed Nakasone of his decision on the Cook Inlet issue that the U.S. wants Japan to increase imports of American coal.

The Japanese official said export of Cook Inlet crude to Japan, when realized, would improve the trade imbalance between the U.S. and Japan, but that would benefit the U.S. more than Japan.

If the U.S. thinks lifting of the export ban was mainly to the benefit of Japan, there is a "perception gap," he said.

However, Noboru Hatakeyama, director general of the Agency's Petroleum Department, said the import of Alaskan oil would contribute to Japan's diversification of oil supply sources as well as to the reduction of huge trade surpluses with the U.S.

Hatakeyama told KYODO News Service that it would have been more significant if the move had come in a tight oil supply situation.

Faced with a relaxation in the oil demand-supply situation, Japan is now receiving calls from China, Mexico, Indonesia and Middle East countries to increase or at least maintain the current level of crude imports from each of them, he said.

"Japan would have to make a sacrifice to import crude from the U.S." Hatakeyama said.

Hatakeyama said MITI is now calmly watching the situation as the timing, price and quantity of exports of Cook Inlet crude are still unclear.

He said a Japanese decision to import Cook Inlet crude should be made on a commercial base.

Commerce Secretary Malcolm Baldrige announced October 28 in Washington that President Reagan had lifted an existing export ban on Cook Inlet oil.

A commerce department spokesman also reportedly said that the U.S. would probably become an exporter of crude oil to Japan and other Asian countries early next year.

Exporting crude from Cook Inlet, located in southern Alaska, does not require a Congressional act, but only a Presidential order, because it does not use Alaskan pipelines to ship oil.

Lifting of the export ban could quickly lead to the export of some 5,900 barrels daily, because sales rights on that amount are held by the Alaskan state government.

But it is up to private interests whether the export would rise above that amount, MITI officials said. Cook Inlet has a daily output capacity of some 55,000 barrels.

The Japanese oil industry generally welcomes the U.S. decision as it is a step toward lifting of a Congressional ban on Alaska's North Slope and other oil fields, and means a diversification of oil supply sources.

An executive of Tokyo Electric Power Co., the prime oil consumer, said the U.S. move to lift the export ban is only significant as a symbol of the gradual removal of trade restrictions.

/7358  
CSO: 4307/002

ENERGY

JAPANESE OIL COMPANIES' INTERIM BUSINESS RESULTS HEAVILY IN RED

Tokyo MARUBENI PETROLEUM REPORT in English 1 Dec 85

[Text] Japan's 10 major oil companies that close their first half-year term in September have reported ¥57.2 billion in combined ordinary losses for the first half of fiscal 1985 (April-September 1985). The large red figure was due to a plunge in "C" fuel oil demand from electric utilities and a stagnation in the oil market.

During the first half, demand for gasoline and the middle distillates continued firm, but sales of "C" fuel oil to the electric utilities fell 5.4 percent this year, to 581.4 million barrels. This notable sales decline was a result of the progress made by the electric power industry in its fuel switching from oil to non-oil energy. In addition, the weak market took its toll on the combined sales of the 10 oil companies, which totaled ¥5,972.4 billion, down 7.8 percent from a year earlier.

Consequently, the profit picture was unimpressive. The stagnant market sent petroleum product prices at retail outlets nosediving, with the dip far exceeding the combined magnitude of the decline in crude prices and foreign exchange gains and expense reductions achieved by the oil companies. Thus most oil companies were forced to run substantial ordinary losses.

In the months ahead, the oil companies will probably do their utmost to pull the market out of the doldrums, while hoping that the strong yen seen since September will remain in place indefinitely.

10 Japanese Oil Companies'\* Business Results  
for Half-Year Term Ended September 1985

	First Half FY1985 <u>(A)</u>	First Half FY1984 <u>(B)</u>	(A)/(B) <u>%</u>
Sales	5,972.4	6,476.7	-7.8
Ordinary Profit/Loss	-57.2	6.7	--
of which Exchange Gain/Loss	-37.1	-25	--
Profit/Loss After Tax	<u>-44.9</u>	<u>- 3.1</u>	<u>--</u>
Sales Volume (mill. of bbl)	581	615	-5.4

Spot Crude Oil Imports at 32.4 Percent in the First Half of Fiscal 1985

Spot crude accounted for 32.4 percent of all crude oil imported by Japan in the first half of fiscal 1985, topping the 30 percent mark on a half-year basis for the first time ever, according to the Petroleum Association of Japan. Specifically, spot crude imports totaled 182 million barrels (996,000 barrels a day), the total imports being 563 million barrels (3,075,000 barrels a day). Thus crude oil's share was about 10 percentage points more than the 22.8 percent a year earlier.

Past statistics show that spot crude, which was responsible for only 5.3 percent of Japan's total crude oil imports in fiscal 1981, constituted 26.1 percent in fiscal 1984 (see MPR No 138). Spot crude imports continued their upward momentum in the current fiscal year, reaching an average 36.0 percent in the July-September quarter.

One factor that has pushed up spot crude's share to such a high level is that with the world oil supply-demand situation continuing slack over the past several years, spot crude prices have remained below the government selling prices of the producing countries. Another factor is that the Japanese oil companies, suffering from deteriorating business performances, tried to reduce crude procurement costs by refraining as much as possible from term-contract purchases at government selling prices. Furthermore, producing countries, beset by the difficulty of selling crude at their official prices, have recently stepped up sales on the spot market.

Since the oil supply-demand situation can hardly be expected to tighten any time soon, the Japanese oil companies will most likely press further ahead

---

\*Nippon Oil Co., Ltd., Maruzen Oil Co., Ltd., Kyodo Oil Co., Ltd., Koa Oil Co., Ltd, Idemitsu Kosan Co., Ltd., Mitsubishi Oil Co., Ltd., Kyushu Oil Co., Ltd., Tao Oil Co., Ltd., General Sekiyu K. K. and Daikyo Oil Co., Ltd.

with the procurement of spot crude. But there is a new move among some producing countries, a move to link the term-contract prices with those of the spot market. If crude imports based on this type of term contract increase, the rise in spot crude's share of Japan's imports may slow down.

#### Trend in Spot Crude's Share of Japan's Crude Oil Imports

	<u>First Half</u>	<u>Entire Year</u>
FY 1982	9.2%	12.0%
1983	17.1	18.7
1984	22.8	26.1
1985	32.4	

#### September-end Oil Stockpile Levels Announced

According to the Ministry of International Trade and Industry (MITI), Japan's oil stockpiles, combining those carried by the private sector and the government, totaled 434.0 million barrels product equivalent (bpe), down 2.9 percent from a year earlier. This volume, comparable to 123.0 days' supply in terms of the 3,522,000 bpe a day recorded for the calendar year 1984, is smaller by 8 days' supply than the year earlier level.

Of the stockpile total, government stocks accounted for 109.4 million bpe, including the 4.8 million bpe added in September, this year's first buildup. Private-sector stocks, however, continued to decrease every month since May, coming to 324.6 million bpe at the end of September.

#### Recent Trends in Japan's Oil Stockpile Levels (on Product Equivalent Basis)

<u>End of Month</u>	<u>Private</u>		<u>Government</u>		<u>Combined</u>	
	mill. of bbl	days supply	mill. of bbl	days supply	mill. of bbl	days supply
1985 April	337.1	96.0	104.6	30.0	441.9	126.0
May	338.4	96.0	104.6	30.0	443.0	126.0
June	336.5	95.0	104.6	30.0	441.1	125.0
July	333.4	94.0	104.6	30.0	438.0	124.0
August	328.0	93.0	104.6	30.0	432.6	123.0
September	324.6	92.0	109.4	31.0	434.0	123.0

- Notes: 1. Crude oil stocks are to be expressed in terms of product equivalent figures converted at the rate of 1 barrel of crude = 0.95 barrel of product.  
 2. All government stocks are kept in the form of crude oil.  
 3. Days supply in fiscal 1985 is to be calculated on the basis of the nation's 1984 oil demand--3,522,000 barrels a day.

The reduction in the private stocks came about as a result of the oil companies' practice of holding their stocks to the lowest possible levels. One reason for this practice was to reduce the cost of carrying stocks. Another reason was that sluggish demand made it unnecessary to carry large inventories.

As already reported in this issue, the oil companies sank into the red for the first half of the current fiscal year. The slack trend in the oil market is expected to carry through into the winter, the peak-demand season. It seems that the oil companies will have no choice but to cut their inventories down to a bare minimum.

### Japanese Oil Statistics

#### Import of Crude Oil by Sources

(Unit: 1000 BBL)

	October, 1985		Jan.-Oct.		Share
	Volume	Share %	Volume	Share %	in 1984 %
Saudi Arabia	10,438	10.5	193,118	18.9	27.2
Kuwait	493	0.5	11,633	1.1	2.3
Neutral Zone	5,210	5.2	65,292	6.4	5.9
Iran	9,249	9.3	72,703	7.1	7.0
Iraq	1,739	1.8	12,401	1.2	0.4
UAE	21,319	21.5	215,944	21.1	15.3
Qatar	8,091	8.2	61,229	6.0	6.0
Oman	9,442	9.5	91,659	9.0	6.3
Others	--	--	--	--	--
Middle East	65,981	66.5	723,979	70.8	70.2
Brunei	1,871	1.9	15,413	1.5	2.2
Indonesia	12,003	12.1	118,392	11.6	13.1
Malaysia	5,375	5.4	33,001	3.2	3.0
S.E. & F.E. Asia	19,249	19.4	166,806	16.3	18.3
Mexico	4,372	4.4	39,753	3.9	4.3
Others	365	0.4	3,894	0.4	0.4
North & South America	4,737	4.8	43,647	4.3	4.7
Nigeria	--	--	--	--	--
Lybia	--	--	--	--	--
Algeria	--	--	--	--	0.3
Others	2,407	2.4	12,597	1.2	0.4
Africa	2,407	2.4	12,597	1.2	0.7
China	6,169	6.2	66,578	6.5	6.0
USSR	64	0.1	926	0.1	0.0
Others	642	0.6	7,687	0.8	0.1
Total	99,249	100.0	1,022,220	100.0	100.0

Source: MITI

/9274

CSO: 4307/003

ENERGY

IDEMITSU TO EXPAND PRC OFFSHORE OIL DRILLING

OW081259 Tokyo KYODO in English 0829 GMT 8 Oct 85

[Text] Tokyo, Oct 8 KYODO--Idemitsu Oil Development Co. said the company and its oil drilling subsidiary, Idemitsu China Oil Development Co., Tuesday signed a contract with China to acquire an additional offshore oil development district in the Beibu offshore area.

An Idemitsu spokesman said the agreement with China National Offshore Oil Corp. calls for Idemitsu to start prospecting the 1,280 square kilometer district, which is between Vietnam and Hainan Island and called Tongking Bay in Vietnamese, from December.

Serious drilling in the district, adjacent to area previously acquired by the companies, will start from October next year, the spokesman said.

/7358  
CSO: 4307/002

ENERGY

MITI URGES MORE INVESTMENT BY POWER, GAS FIRMS

OW151351 Tokyo KYODO in English 1223 GMT 15 Oct 85

[Text] Tokyo, Oct 15 KYODO--Minister of International Trade and Industry Keijiro Murata Tuesday asked representatives of electric power and gas companies to make additional investments in plant and equipment totaling 1.1 trillion yen to boost domestic demand and help solve trade friction, officials said.

Shoichiro Kobayashi, chairman of the Federation of Electric Power Companies and president of Kansai Electric Power Co., said the nation's nine electric power firms will make every effort to raise their capital investment by 1 trillion yen by the end of fiscal 1988.

Combined capital investments by the nine electric power firms are now expected to total some 10 billion yen in the next three fiscal years, the officials said.

Hiroshi Watanabe, vice chairman of the Japan Gas Association and president of Tokyo Gas Co., said three major gas firms in Tokyo, Osaka and Nagoya will make additional capital investments of 100 billion yen in the next three years.

Murata asked Kobayashi and Watanabe for their cooperation in implementing the government's new package of measures announced earlier in the day to expand domestic demand and raise imports, the officials said.

/7358

CSO: 4307/002

ENERGY

MITI TO SUBMIT GASOLINE IMPORT DECONTROL BILL

OW041127 Tokyo KYODO in English 1106 GMT 4 Oct 85

[Text] Tokyo, Oct 4 KYODO--The Minister of International Trade and Industry (MITI) has decided to submit to the next extraordinary session of the Diet a bill to facilitate imports of refined petroleum products, including gasoline, MITI officials said Friday.

The bill will follow recently released recommendations of the petroleum council, which suggested placing no limits on the quantity of imports but restricting the right to import to refiners, according to Toshihiko Tanabe, director of the Policy Planning Division of the Petroleum Department at the Natural Resources and Energy Agency, a MITI affiliate.

Trading houses will not be permitted to import gasoline because they would create excessive competition with deficit-ridden oil refining companies, which depend on gasoline as their only profit-making product, Tanabe said.

Considerations of maintaining a stable supply of all petroleum products for national security reasons also contributed to the decision to limit imports to refiners, Tanabe said.

The European Community and the United States have recently requested that Japan open up its gasoline market to imports in order to share the burden of refined products soon to be exported from Mideast oil producing countries for the first time.

Prime Minister Yasuhiro Nakasone asked MITI Monday to speed up procedures to facilitate the import of gasoline.

Assuming the bill passes the Diet in the extraordinary session starting in mid-October, gasoline imports could begin as soon as early next year.

However, industry analysts predict only a small volume of imports, perhaps 5 to 10 percent of domestic demand, because the refining industry is suffering from overcapacity, running at only 60 percent of capacity.

/7358  
CSO: 4307/002

ENERGY

TDK AFFILIATE DEVELOPS NEW SOLAR POWER CELL

OW210741 Tokyo KYODO in English 0727 GMT 21 Nov 85

[Text] Tokyo, Nov 21 KYODO--Semiconductor Energy Laboratory Co., affiliated with TDK Corp., said Thursday it has developed a less costly solar power generating cell capable of changing sunlight into electricity more efficiently, paving the way to produce commercially viable solar power generators.

A spokesman for the laboratory called the new amorphous--non-crystal--photovoltaic cell a breakthrough, saying it will lead to wide use of solar power stations by electric power companies. Commercial production of the new cell is scheduled to start next fall, he said.

Photovoltaic cells generate voltage when radiant energy fall on the boundary between dissimilar semiconductors. Amorphous cells are expected to be used for large-scale power generating systems because they are more economical and efficient than costly crystal semiconductor cells which are now built into electric appliances such as calculators.

The laboratory made a square prototype--1 cm by 10 cm--consisting of 15 amorphous cells, using its laser technology. The laboratory claims the prototype can convert 9.9 percent of solar heat into electric energy, more efficient than conventional amorphous cells, which convert about 8 percent a spokesman said.

/7358  
CSO: 4307/002

NUCLEAR DEVELOPMENT

CONSTRUCTION BEGINS ON ENRICHED URANIUM PLANT

OW130327 Tokyo KYODO in English 0214 GMT 13 Nov 85

[Text] Ninyotoge, Okayama Pref., Nov 13 KYODO--The Power Reactor and Nuclear Fuel Development Corp. Wednesday started construction here of a plant to produce enriched uranium for use at a nuclear power station to be constructed in Aomori Prefecture in northern Japan.

A prototype plant is aimed at developing mass production of the nuclear fuel using the centrifuge method, corporation officials said.

When completed in 1987, the new plant will produce enough fuel to operate a nuclear power station with maximum generation capacity of 1 million kilowatt-hours.

Another prototype plant with the same capacity will be built here next year.

Japan has been pushing production of enriched uranium using the centrifuge method as a national project since 1972.

In 1978, the governmental corporation completed a pilot plant to produce enriched uranium.

About 200 people, including corporation chief Noboru Yoshida and Ken Naito, vice parliamentary minister at the Science and Technology Agency, were present at ceremonies marking the start of plant construction.

/7358

CSO: 4307/002

NUCLEAR DEVELOPMENT

MITI ADVISORY GROUP TO WORK OUT NUCLEAR POLICY

OW110919 Tokyo KYODO in English 0858 GMT 11 Nov 85

[Text] Tokyo, Nov 11 KYODO--An Advisory Council to the International Trade and Industry minister decided Monday to work out a long-term nuclear energy policy by next July.

The nuclear subcommittee of the Advisory Committee for Energy, headed by Vice Chairman Isamu Yamashita of the Federation of Economic Organizations (Keidanren), will discuss various policies and measures surrounding the nation's nuclear energy industry up to the year 2030, when Japan is expected to establish its own nuclear fuel cycle and introduce a fast breeder reactor on a full-fledged basis, council officials said.

The 35-man subcommittee will also discuss the best combination of energy sources, including fossil fuels, for Japan's needs, as well as environmental problems, the officials said.

/7358  
CSO: 4307/002

SCIENCE AND TECHNOLOGY POLICY

COCOM TO EASE CONTROL ON HIGH-TECH EXPORTS TO PRC

OW110249 Tokyo KYODO in English 0240 GMT 11 Nov 85

[Text] Tokyo, Nov 11 KYODO--The Coordinating Committee for Export to the Communist Bloc (COCOM) is likely to ease considerably its controls on China-bound exports of high technology products in December, government officials said Monday.

The Paris-based, 15-nation watchdog on Western exports to communist countries will allow member countries to export some 40 manufactured goods including almost all computers and numerically-controlled machine tools to China without obtaining COCOM approval, the officials said.

They said the action is aimed at increasing exports of Western high technology to China, which has already been placed under less severe restrictions than other communist nations.

COCOM will however, tighten its control on exports of industrial robots and possibly biotechnology products to the communist world, they said.

The COCOM list of export restrictions varies from country to country, with Japan currently controlling 164 items, including weapons and atomic power facilities.

/7358

CSO: 4307/002

END